

AD-A074 048

HAROLD LEONARD STUART SCHOOL OF MANAGEMENT AND FINANC--ETC F/6 9/2
DESIGN OF INCOMING QUALITY LEVEL, PROCESS QUALITY LEVEL AND OPT--ETC(U)
APR 79 M Z HASSAN, T W KNOWLES, R SUBRAMANIAM N00014-76-C-0841
NL

UNCLASSIFIED

| OF |

AD
A074048



END
DATE
FILMED
10-79
DDC

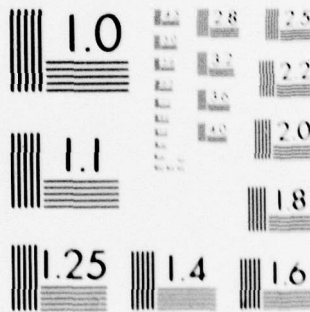

MICROCOPY RESOLUTION TEST CHART
NATIONAL BUREAU OF STANDARDS-1963-A

LEVEL 1

12

D D C
RECEIVED
SEP 19 1979
RECEIVED
C

A074048

A USER'S MANUAL FOR DMQS

**DESIGN OF INCOMING QUALITY LEVEL,
PROCESS QUALITY LEVEL AND
OPTIMAL INTERRELATED LOT-BY-LOT
SINGLE SAMPLING PLANS FOR A
SINGLE-PRODUCT MULTI-COMPONENT
MULTI-STAGE MANUFACTURING SYSTEM**

M. Zia Hassan
Thomas W. Knowles
R. Subramaniam
A. Manaspati
P. Pantumsinchai

Research supported by the
Office of Naval Research
under Contract No. N00014-76-C-0841

April 1979

The document has been approved
for public release and sale; its
distribution is unlimited.

411381

DDC FILE COPY
→

Department of Management Sciences
Harold Leonard Stuart School of Management and Finance

IIT ILLINOIS INSTITUTE OF TECHNOLOGY
IIT CENTER
CHICAGO, ILLINOIS 60616

79 09 18 137

UNCLASSIFIED

SECURITY CLASSIFICATION OF THIS PAGE (When Data Entered)

REPORT DOCUMENTATION PAGE		READ INSTRUCTIONS BEFORE COMPLETING FORM
1. REPORT NUMBER N00014-76-C-0841	2. GOVT ACCESSION NO.	3. RECIPIENT'S CATALOG NUMBER --
4. TITLE (and Subtitle) A USER'S MANUAL FOR DMQS - DESIGN OF INCOMING QUALITY LEVEL, PROCESS QUALITY LEVEL AND OPTIMAL INTERRELATED LOT-BY-LOT SINGLE SAMPLING PLANS FOR A SINGLE-PRODUCT MULTI-COMPONENT MULTI-STAGE MANUFACTURING SYSTEM	5. TYPE OF REPORT & PERIOD COVERED Research	
	6. PERFORMING ORG. REPORT NUMBER	
7. AUTHOR(s) M. Zia Hassan, Thomas W. Knowles, R. Subramaniam, A. Manaspiti, P. Pantumsinchai	8. CONTRACT OR GRANT NUMBER(s) N00014-76-C-0841 ¹²	
9. PERFORMING ORGANIZATION NAME AND ADDRESS Illinois Institute of Technology Chicago, IL 60616	10. PROGRAM ELEMENT, PROJECT, TASK AREA & WORK UNIT NUMBERS NR042-360	
11. CONTROLLING OFFICE NAME AND ADDRESS Office of Naval Research Arlington, Virginia 22217	12. REPORT DATE 1979	
	13. NUMBER OF PAGES 74	
14. MONITORING AGENCY NAME & ADDRESS (if different from Controlling Office) ONR Branch Office 536 S. Clark Street Chicago, IL 60605	15. SECURITY CLASS. (of this report) Unclassified	
	15a. DECLASSIFICATION/DOWNGRADING SCHEDULE	
16. DISTRIBUTION STATEMENT (of this Report) Distribution of this document is unlimited		
17. DISTRIBUTION STATEMENT (of the abstract entered in Block 20, if different from Report)		
18. SUPPLEMENTARY NOTES		
19. KEY WORDS (Continue on reverse side if necessary and identify by block number) Manufacturing Systems, Interrelated Lot-by-Lot Sampling Plan, Rectification Plan, AOQ, ATI, Dynamic Programming, Computer Program, AOQL		
20. ABSTRACT (Continue on reverse side if necessary and identify by block number) This is a user's manual for computer program for the design of incoming quality level, process quality level and optimal interrelated lot-by-lot single sampling plans for a single-product multi-component multi-stage manufacturing system. Reference: Hassan, M. Z. and Knowles T. W., "An Optimal Quality Control Design for a Single-Product Serial Manufacturing System", <u>Journal of Quality Technology</u> , Vol. 11, No. 1, January, 1979.		

DD FORM 1473
1 JAN 73

EDITION OF 1 NOV 68 IS OBSOLETE
S/N 0102-014-6601

UNCLASSIFIED

SECURITY CLASSIFICATION OF THIS PAGE (When Data Entered)

A USER'S MANUAL FOR DMQS .

6 DESIGN OF INCOMING QUALITY LEVEL,
PROCESS QUALITY LEVEL AND OPTIMAL INTERRELATED LOT-BY-LOT
SINGLE SAMPLING PLANS FOR A SINGLE PRODUCT
MULTI-COMPONENT MULTI-STAGE MANUFACTURING SYSTEM •

BY

10 M. ZIA/HASSAN,
THOMAS W./KNOWLES,
R./SUBRAMANIAM,
A./MANASPITI
P./PANTUMSINCHAI

12 82p.

~~Illinois Institute of Technology~~

Department of Management Sciences

~~Harold Beard Street~~
Chicago, Illinois 60616

11 Apr 1979

9 Research rept.

Research supported by the Office of Naval Research

under Contract No. 15 ~~NO0014-76-C-0841~~

Reproduction in whole or in part is permitted
for any purpose of the United States Government.

411381

Gu

AVAILABILITY OF THE DMQS SYSTEM

The DMQS system is available to any one desiring a copy. A computer listing on paper is available at no charge. The program contains more than 2,000 statements. There is a nominal charge, to cover expenses, for a listing on tape. There is no charge if a computer tape is accompanied with the request. For further information, write:

Dr. M. Zia Hassan, DMQS Project Director
Department of Management Sciences
Illinois Institute of Technology
Chicago, Illinois 60616

Accession For	
NTIS GRA&I	<input checked="" type="checkbox"/>
DDC TAB	<input type="checkbox"/>
Unannounced	<input type="checkbox"/>
Justification _____	
By _____	
Distribution/ _____	
Availability Codes	
Dist	Avail and/or special
A	

TABLE OF CONTENTS

Section	Page
1.0 INTRODUCTION	1
2.0 PROBLEM DESCRIPTION AND TERMINOLOGY	2
2.1 The General Recursive Relationship	2
2.2 Inspection Station	2
2.2.1 Inspection Station Costs	3
2.2.2 Inspection Station Recursions	4
2.3 Manufacturing Station	4
2.3.1 Manufacturing Station Cost	5
2.3.2 Manufacturing Station Recursions	5
2.4 Assembly Station	6
2.4.1 Assembly Station Costs	6
2.4.2 Assembly Station Recursions	6
3.0 PROGRAM OVERVIEW	8
3.1 Consistency of Assembly Chart	9
3.2 State and Decision Variable Grids and FMAX Value	9
3.3 Explanation of the Program Elements	10
3.4 Size Limitations of the Program	12
4.0 INPUT	14
4.1 Schematic Diagram of Input/Output Files	14
4.2 To Create Input for a Problem	15
4.3 Input Sections	17
4.3.1 Quality Characteristics	18
4.3.2 Structure	19
4.3.3 Inspection Costs	20

4.3.4	Raw Material Costs	21
4.3.5	Manufacturing Costs	22
4.3.6	Assembly Costs	23
4.4	Cost Function Input Formats	24
4.4.1	Type 0	25
4.4.2	Type 1	27
4.4.3	Type 2,3,...9	28
5.0	OUTPUT	29
5.1	Summary Report Table	29
5.2	Complete Output	31
5.3	Interpretation of Outputs and An Example	35
5.3.1	Manual Trace-Back Procedure	35
5.4	Suboptimal Conditions and Alternative Solutions	39
6.0	POSSIBLE MODIFICATIONS TO THE PROGRAM	41
6.1	How to Accomodate a Larger Problem	41
6.2	Rewinding of Input Data File	42
	BIBLIOGRAPHY	44
	APPENDICES	45
A	AN EXAMPLE OF THE OUTPUTS	45
B	THE LISTING OF THE MAIN PROGRAM	69
C	THE LISTING OF THE SUBROUTINE COSTFN	72

LIST OF TABLES

Table	Page
3.1 Program Elements	11
4.1 Example Structure Naming	16
4.2 Types of Cost Functions	24
5.1 Column Headings - Summary Report	30
5.2 Output Column Usage	30
5.3 Inspection Station Output	32
5.4 Manufacturing Station Output	33
5.5 Assembly Station Quality Aggregation Output	34
5.6 Assembly Station Decision Variable Output	34
5.7 State Variable Names - By Stations	36
6.1 Parameters Definitions	42
6.2 Input/Output Device Parameters	42

LIST OF FIGURES

Figure	Page
2.1 Inspection Station	3
2.2 Manufacturing Station	5
2.3 Assembly Station	6
3.1 Wrong Arrangement for Size Violation	13
3.2 Correct Arrangement for Size Violation	13
4.1 Schematic Diagram of Input/Output Files	14
4.2 Example Assembly Chart	16
4.3 Example Assembly Chart - Modified	17
4.4 Input Data Organization	18
4.5 Sample Cost of Type 0	25
4.6 Type 1 Cost Function	27
5.1 Assembly Station Quality Aggregation	33
5.2 System Structure - An Example	37
5.3 Solution of the Example	39

1.0 INTRODUCTION

The program designs manufacturing-quality control systems to minimize the expected operating cost of a single product for a user specified Average Outgoing Quality Limit, (AOQL). The costs considered are: raw materials, inspection, repair or replenishment of defectives, manufacturing and assembly. The sampling plans are single sampling by attributes on a lot-by-lot basis. The lot size is specified by the user.



The program is written in FORTRAN for the UNIVAC 1108 at the Illinois Institute of Technology and was designed for ease of modification for other computer installations. The program uses forward recursion dynamic programming to solve the problem. The decision variables include the sampling plans (n and c), the fraction defective generated by a manufacturing or assembly process, and the quality characteristics of the raw materials.

The underlying cost models assume that a large number of lots of the products are to be processed and the decision rules are independent of the actual outcome of the rules at previous stages. The generation of additional defects at a stage is assumed to be independent of the defects generated at previous stages. Inspection is assumed to be perfect, and defects generated at any previous stages are also detected if a unit is inspected.

Section 2 describes the problem, solution approach and terminology used. Section 3 is an overview of the computer program. Section 4 specifies the input format. Section 5 describes the output and interpretation. Section 6 describes possible modification of the program.

2.0 PROBLEM DESCRIPTION AND TERMINOLOGY

The model may be composed of the following types of stations:

<u>Station Type</u>	<u>Symbol</u>
Inspection	
Manufacturing	
Assembly	

In this section each of the station type's cost will be defined and the recursive relationship shown. First the basic solution approach will be discussed in 2.1.

2.1 The General Recursive Relationships

The program uses forward recursion dynamic programming. The state variable linking the successive stations is the average fraction defective in the lot. To discuss a general station, let us call the average incoming quality the p_I and the average outgoing quality AOQ. The minimum cost for all the stations up to and including the one under consideration, say n , is denoted by $f_n(\text{AOQ})$ and depends upon the value of AOQ resulting. The basic recursive relation is

$$f_n(\text{AOQ}) = \min_{\substack{\text{decision} \\ \text{variables} \\ \text{of station } n}} \left\{ \text{stage } n \text{ cost} + f_{n-1}(p_I) \right\}$$

where AOQ is a function of p_I and the decision variable at that station. The program implementation establishes a grid of values on the state variables and any continuous decision variables.

2.2 Inspection Station

An inspection station sampling plan is specified by (n,c) . A random

sampling of size n is selected from the lot (of size N). If the number of defectives in the sample is c or less, the discovered defects are repaired (or replaced with good ones) and no more inspection is done on that lot. If there are more than c defectives, the entire unsampled portion of the lot ($N-n$) is inspected and all defectives repaired. This is called a single sampling plan with rectification; the quality of performance will be at least as good after sampling as before. Symbolically, the inspection station may be represented as in Figure 2.1.

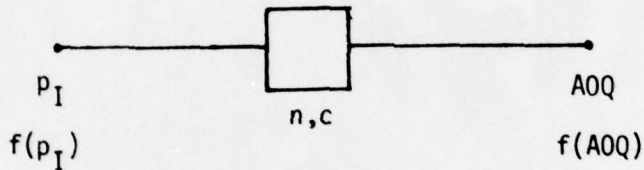

Figure 2.1 Inspection Station

For a particular value of AOQ , the utility of the inspection is considered by comparison of $f_n(AOQ)$ with $f_{n-1}(AOQ)$. Note that for an inspection station to have a feasible plan, $AOQ < p_I$

For the final inspection station, the average outgoing quality limit $AOQL$ is used instead of AOQ as the state variable and $f_n(AOQL)$ is the minimum average total cost associated with the $AOQL$. The plan (n, c) for the final inspection station will guarantee that the average outgoing quality AOQ for any value of p_I is less than or equal to $AOQL$.

2.2.1 Inspection Station Costs

The expected cost of inspection at an inspection station is denoted by $k_2 \cdot ATI$ where ATI is the average total inspection: $ATI = n + (N-n)(1-P_a)$ where P_a is the probability of accepting the lot. The cost

per unit inspected is denoted by k_2 . The expected repair cost is denoted by $k_1 \cdot \text{ATI} \cdot p_I$ where p_I is the fraction defective in the lot and hence $\text{ATI} \cdot p_I$ is the expected defectives to be repaired. k_1 is the cost per unit repaired. The expected cost at an inspection station is of the form $(k_1 \cdot p_I + k_2)\text{ATI}$. The probability of acceptance is

$$\sum_{x=0}^c \frac{(np_I)^x e^{-np_I}}{x!}$$

2.2.2 Inspection Station Recursions

The inspection station could be associated with the inspection of raw materials or after a manufacturing or assembly station. If the inspection is of a raw material and no manufacturing has been done on the component, then the recursive relation is

$$f_1(\text{AOQ}) = \min_{p_I, n, c} \{k_4 N + (k_1 p_I + k_2) \text{ATI}\}$$

where k_4 is the cost/unit of the raw materials and may be a monotonically nonincreasing function of p_I . The resulting Average Outgoing Quality, AOQ, equals $p_I P_a(N-n/N)$.

If the inspection is of a component which has one or more previous manufacturing or assembly stages, the recursive relationship is

$$f_n(\text{AOQ}) = \min_{n, c} \{(k_1 p_I + k_2) \text{ATI} + f_{n-1}(p_I)\}$$

2.3 Manufacturing Station

At a manufacturing station, each of the N units in the lot are manufactured. Symbolically, the manufacturing station may be represented

as in Figure 2.2. The manufacturing operation generates additional defectives with a probability of p' for each unit. Thus, the resulting output has a quality of conformance no better than that of the input, and probably worse.

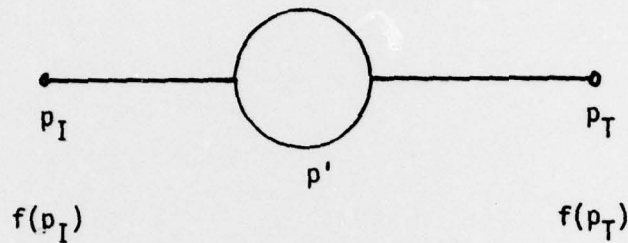

Figure 2.2 Manufacturing Station

2.3.1 Manufacturing Station Cost

If the cost/unit manufactured is k_3 the manufacturing cost for the whole lot is k_3N . The cost/unit k_3 may vary as p' is changed. Assume that the value of k_3 is monotonically non-increasing with p' (i.e. k_3 stays the same or decreases as p' increases).

2.3.2 Manufacturing Station Recursions

Let $f_{n-1}(p_I)$ be the minimum expected cost for the station previous to stage n as a function of the fraction defective incoming to stage n , p_I . Then the recursive relationship is

$$f_n(p_T) = \min_{p'} \{N \cdot k_3 + f_{n-1}(p_I)\}$$

where p_T is the average outgoing quality level for a manufacturing stage

$$p_T = p' + p_I - p'p_I.$$

2.4 Assembly Station

At an assembly station two or more components are assembled (and/or processed) into a single component. The aggregation of the components results in an Aggregate Incoming Quality, p_{AI} . Furthermore, the assembly and/or processing of the components may generate additional defectives with a probability of p' . Figure 2.3 represents this symbolically.

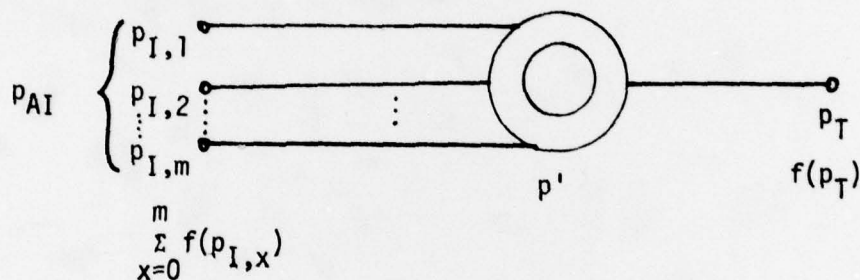

Figure 2.3 Assembly Station

The quality of incoming component x is called $p_{I,x}$.

2.4.1 Assembly Station Costs

Let k_5 be the cost/unit of the assembly operation. Then the assembly cost is Nk_5 because the entire lot must be assembled. This cost/unit may be allowed to vary as p' (the probability of a defective generated by the assembly) varies. Assume that the value of k_5 is monotonically non-increasing function of p' .

2.4.2 Assembly Station Recursions

The assembly station recursion consists of two phases for each assembly station. In the first phase, $f(p_{AI})$ is determined. In the second phase, the recursion is

$$f_n(p_T) = \min \{Nk_5 + f(p_{AI})\}$$

where

$$p_T = p' + p_{AI} - p'p_{AI}$$

In the first phase, the components are aggregated first by aggregating the first two components to obtain an aggregated $\hat{f}(p_{AI})$. Then the result is aggregated with the third component to get a new $\hat{f}(p_{AI})$. This continues aggregating one additional each time until all are aggregated, and the result is then called $f(p_{AI})$. The general step in this phase would be

$$\hat{f}(\hat{p}_{AI}) = \min_{p_{I,x} \cdot p_{AI}} \{f(p_{I,x}) + f(p_{AI})\}$$

where

$$\hat{p}_{AI} = p_{AI} + p_{I,x} - p_{AI}p_{I,x}$$

3.0 PROGRAM OVERVIEW

The program was written in FORTRAN V on the UNIVAC 1108 at Illinois Institute of Technology. It was designed for ease of use at other installations and on other types of computers. The files used are described in Section 4.1.

The manual describes the use of the program for the multi-component, multi-stage manufacturing system in which there is one or more assembly stages. The single-component multi-stage manufacturing system is thus a special case and is treated in the obvious manner. It is assumed that each station has at most one successor and only an assembly station may have more than one direct predecessor.

The term component is used to describe the (perhaps) partially completed product resulting from any station. Note that the output (component) for one station is the input (component) for its direct successor.

The term stage is from the terminology of dynamic programming. It refers to the column location on an assembly chart (Section 4.2).

The program has an elaborate input checking system which is described in Section 4.0. The basic rules for the problem structure are summarized in 3.1. The algorithms described in Section 2 use dynamic programming forward recursions. The subroutine PRØDN uses the algorithm for a manufacturing station. The subroutine ASSMBY is called to find $f(p_{AI})$ as each assembly component is added. The subroutine PRØDN is then called to determine the minimum cost for P_T .

Since the ATI term is used for all inspection stations except for the final inspection, it is convenient to create a set of tables which results in minimum ATI for various values of p_I and AOQ. Subroutine INSP1 does this. The calculations varying p_I for a specified AOQ are done by subroutine INSP2. The final inspection station, subroutine INSFIN performs the optimization to obtain the specified AOQL.

Upon processing of the station for the final product, backtracking must be done through the sequentially generated station solution table in order to find the optimal solution. This is done by the subroutine BAKTRK.

3.1 Consistency of Assembly Chart

The following conditions must be met when using the program. They are referred to as the rules for the consistency of the assembly chart.

1. There must be at least two stages.
2. The numbering of stages and components must be consecutive starting from one, i.e. 1, 2, 3, ..., etc.
3. There must be at least one station for each component number and for each stage number.
4. No two inspection stations can be placed consecutively along a component.
5. For an assembly station at least two components must be assembled.
6. There can be one and only one component resulting from an assembly station and for the resulting component there must be at least one station (of any type) in one of the following stages. The resulting component number must be one of the incoming component numbers for the assembly station under consideration.
7. The last stage of the manufacturing system must be an inspection station.

3.2 State and Decision Variable Grids and FMAX Value

Since the algorithm employs dynamic programming and the state variables and decision variables (other than n and c) are continuous, it is necessary to provide a finite grid of values for the continuous variable.

In practice it makes little sense to use a grid smaller than 0.5% because of the accuracy of controls and cost estimates. The user must provide the grid size desired for these variables. The same grid size is used for all state variables. The grid sizes for the decision variable for manufacturing and assembly stations may be different. The program uses 0.5% for the finest possible grid size and rounds all values on that basis.

The maximum limit on the average fraction defective from a lot is conceptually 100%. Usually the range of interest is much smaller. The program allows the user to specify a maximum which is smaller than 100%. This allows a possible suboptimal solution to be obtained. The limit is specified by employing a constant multiplicative factor, called FMAX on the value of AOQL. For example, if the AOQL value is 0.05 and FMAX value is 2.0, then, the maximum value of the state variable is 0.10 ($FMAX * AOQL$) throughout the system. It should be noted that the larger the FMAX value is, the more unlikely a suboptimum becomes. However the price is that the computation time is prolonged.

3.3 Explanation of the Program Elements

The program has 23 elements, one of which is the MAIN program. Every statement in each element has a sequence of numbers for ease of ordering. The first three characters of the statement number represent an abbreviation of the name of the element. The following table gives the names of the elements (subroutines), where they are called from, their abbreviations, number of statements in each element and their basic functions.

Table 3.1 Program Elements

Program Element	Called From	Abbreviation	# of Statements	Basic Function Performed
MAIN	-	MIN	107	Sets parameters and calls other subroutines.
CØNTRL	MAIN	CTL	398	Controls calling of subroutines according to the structure of a problem. It also defines the Random Access File and controls output.
INPUT	MAIN	IPT	369	Reads input and controls other input reading subroutines.
RAWMAT	INPUT	RAW	87	Reads inputs costs for raw materials.
INSPEC	INPUT	ISP	42	Reads input costs for inspection station.
PRØCES	INPUT	PCS	77	Reads input cost for manufacturing station.
ASSEMB	INPUT	ASM	80	Reads input costs for assembly station.
CØSTFN	PRØCES ASSEMB RAWMAT	CFN	84	Generates cost coordinates according to the specified cost functions 1,2,...,9.
RANK	PRØCES RAWMAT ASSEMB	RNK	72	Ranks the set of cost coordinate pairs to determine whether or not they are monotonically non-increasing function of p.
Algorithm Subroutines				
PØISSN	INSP1	PSN	17	Calculates the probability of acceptance based on Poisson Distribution.
INSP1	ATINC	IP1	73	Generates tables of ATI, n and c.

INSP2	CØNTRL	IP2	125	Algorithm for inspection station.
INSFIN	CØNTRL	IFN	71	Algorithm for Final Inspection Station.
ASSMBY	CØNTRL	ABY	68	Algorithm for assembly station.
PRØDN	CØNTRL	PDN	87	Algorithm for manufacturing and assembly station.

Subroutines for Output

DISK	CØNTRL	DSK	39	Writes station outputs to the Random Access File.
BAKTRK	CØNTRL	BTK	93	Backtracking according to the structure of the problem obtains and reports optimal solution from the Random Access File.
DATOUT	MAIN	DAT	75	Prints some outputs.

Auxiliary Subroutines

HEAD	CØNTRL DATØUT INPUT	HED	10	Prints heading.
SETMX	CØNTRL	SMX	19	Arranges data before calling INSP2.
ATINC	MAIN	ANC	82	Arranges data and calls INSP1.
ZERØIN	INSP1	ZEN	52	Searches for value of n for each values of AIQ, AOQ, and c.
FCT	ZERØIN	FCT	72	Function subroutine.

3.4 Size Limitations of Program

There is really no limit to the size of the problem that the program can solve in terms of the number of components and/or stages unless the capacity of the computer is exceeded.

However, it should be pointed out that a maximum of only 999 components of each type can be accommodated in any stage. Since there is no limit on the number of stages, we can always create additional stage(s) to accommodate any number of excess stations of one type beyond 999.

For example, if we have a problem which requires 1500 components and each of these components has to be inspected as soon as it enters our system. The problem may look like Figure 3.1.

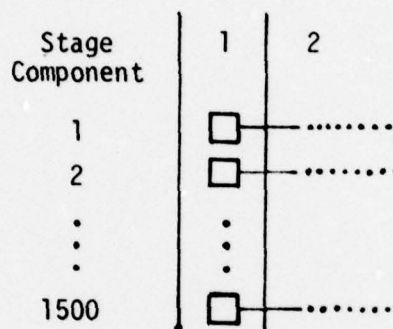

Figure 3.1 Wrong Arrangement for Size Violation

In order to satisfy the constraint, we can create an additional stage and perhaps arrange the stations as in Figure 3.2.

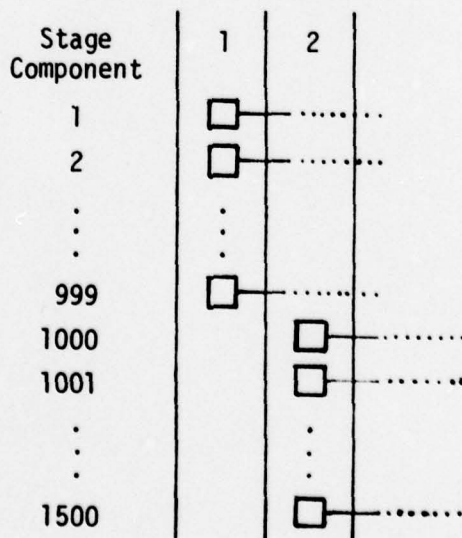

Figure 3.2 Correct Arrangement for Size Violation

4.0 INPUT

This program package consists of 23 elements, 2 of which can be modified by the user in order to accommodate a bigger size problem (e.g. more components or stages) or to fit their own type of cost function.

The two elements are

1. MAIN Program
2. SUBROUTINE COSTFN.

See Section 6: Possible Modifications of the Problem.

The users are required to prepare input data and place them on a sequential data file. The program reads the input data and provides diagnostic messages (if any) so that the user can correct their input easily. Diagnostics are usually the result of

- (i) miss-typing of input statements.
- (ii) dimensions of some arrays exceeded.

If there is any error that the program can detect, the program will not proceed to calculate the optimal solution but instead a partial output with diagnostic messages will be provided to identify the sources of the errors.

4.1 Schematic Diagram of Input/Output Files

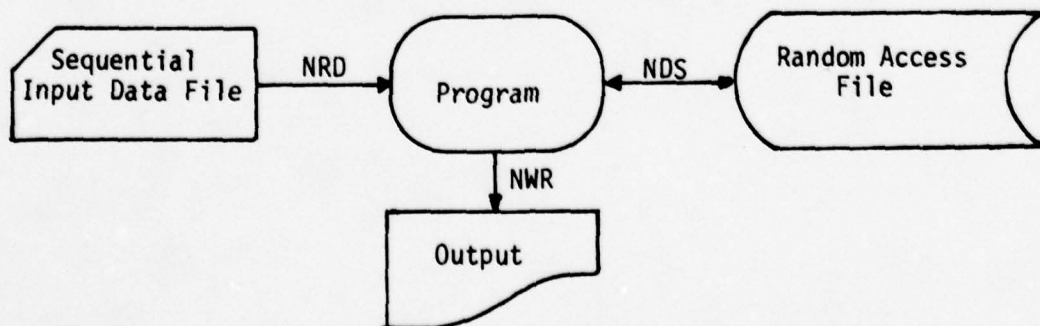

Figure 4.1 Schematic Diagram of Input/Output Files

The Input Data File is assumed to be sequential and is read by the I/O-variable-name called NRD. Each record is assumed to be of 80 bytes long (similar to an 80 column card). The file is formatted.

The Random Access File is created by the Fortran DEFINE FILE statement. The program will determine the size of this file. Its I/O variable is NDS. If the program detects any error (hence computation will be terminated by the program) this file will not be created. It is to be created as an unformatted 48-byte record file, if there is no error.

The Output File assumes the standard 133 character record file for the paper printouts. Its I/O variable name is NWR.

4.2 To Create Input for a Problem

Since there are only 3 types of stations allowed in a problem i.e. Manufacturing, Assembly and Inspection. The letters M, A, I, represent them, respectively.

Every station must be identified by component-number and stage-number as well as its type. In addition a station may or may not have a name associated with it depending on its type. The following rules must be adhered to:

1. Each station in the system is allowed to have a name with a maximum of 4 characters.
2. Every assembly station must have a name. This is necessary since two or more components will be assembled into one and hence it is necessary to know which station assembles them.
3. Naming for M and I stations is optional because such stations are uniquely identified by their component-numbers and stage-numbers.

Consider a simple manufacturing system in which two components are assembled into one unit as in Figure 4.2.

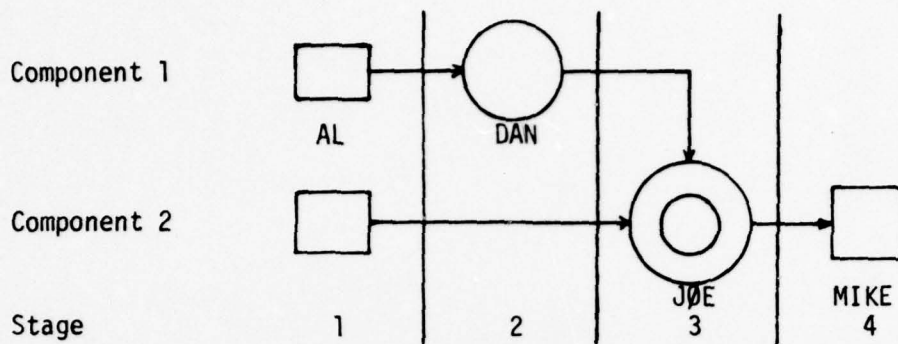

Figure 4.2 Example Assembly Chart

The assembly chart is constrained to be as compact as possible to the left and the components and stages are numbered accordingly. This manufacturing system can be described as having two components and four stages. In the third stage, the first component after manufacturing is assembled with component 2, and the assembled unit is inspected at the inspection station called MIKE. This component could be numbered either 1 or 2 - See Section 3.1. (See also STRUCTURE Section 4.3.2.) We identify the problem as in Table 4.1.

Table 4.1 Example Structure Naming

Component	Stage	Station Type	Station Name
1	1	I	ALØØ*
1	2	M	DANØ
1	3	A	JØEØ
2	1	I	ØØØØ
2	3	A	JØEØ
2	4	I	MIKE

* Ø = blank

Suppose that, in reality, we are producing a lot size of 1000 units and two units of component #1 are required for each assembly. Since all

lot sizes must be the same, then we create another fictitious component called #3 which is the same item as #1, each with a lot size of 1000. Figure 4.3 shows how the assembly chart would have to be modified.

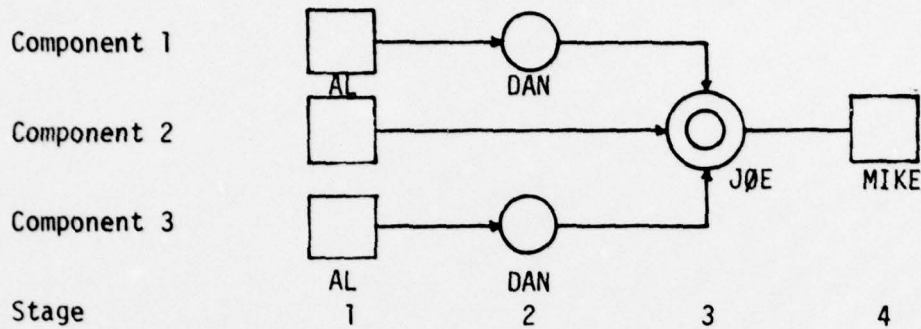

Figure 4.3 Example Assembly Chart - Modified

Although in Stage 1, we have 2 inspection stations called "AL" they are not taken as the same station by the program because they have different component-numbers, i.e. 1 and 3. Similarly for the processing stations in stage 2, they are treated independently even though they have the same name, DAN. Therefore cost data must be given for each of them separately, but the data will be the same.

4.3 Input Sections

The input data required by the program may be divided into sections as follows:

1. QUALITY CHARACTERISTICS
2. STRUCTURE
3. INSPECTION COST
4. RAW MATERIAL COST
5. MANUFACTURING COST
6. ASSEMBLY COST

It is instructive to consider each record in the sequential input data file as an 80-column card.

Note: Columns 61-80 are reserved for comments.

Each input section has a title card and the last card in the data file is the ENDATA card as shown below.

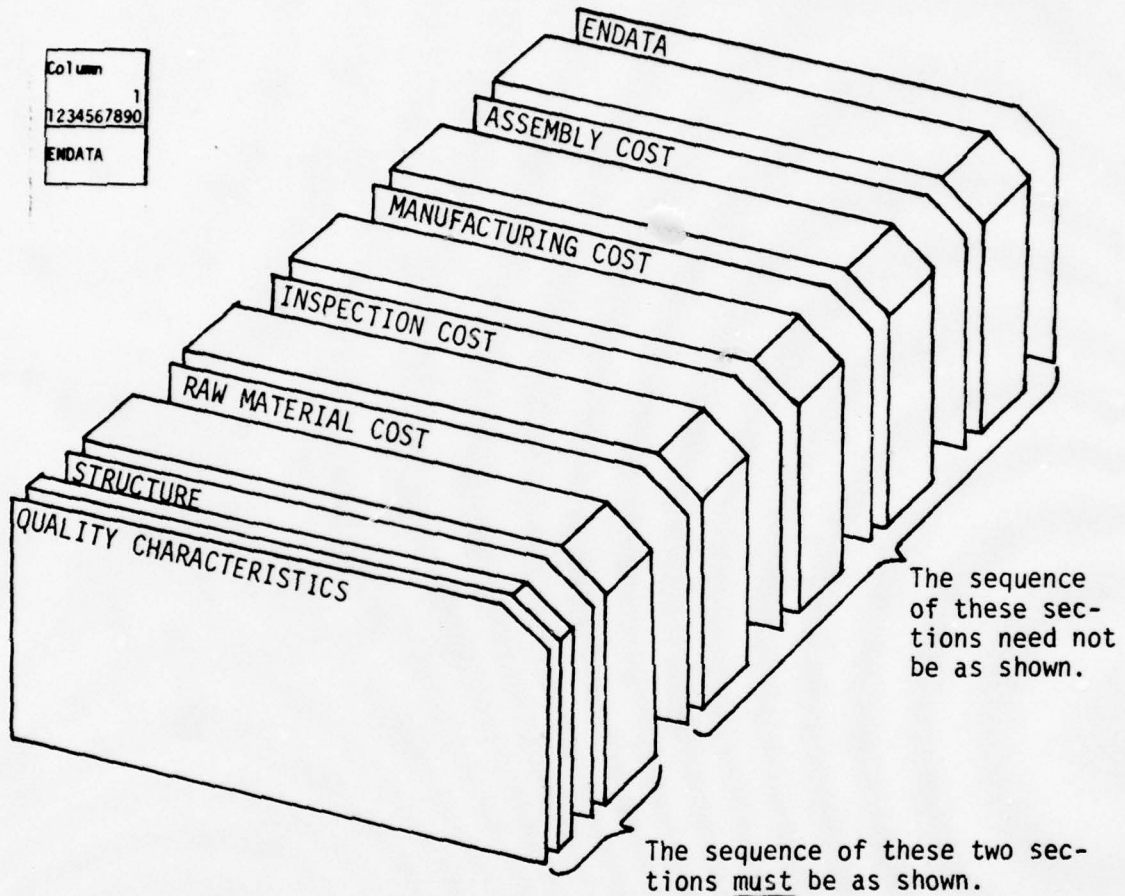

Figure 4.4 Input Data Organization

Each section will now be discussed in detail.

4.3.1 Quality Characteristics

This section must be first in the data file. It consists of two cards only. The first card is the title card. Its content is:

Title Card

Column							
1	2	3	4	5	6	7	8
INSPECTION COSTS							
							Comments

Subsequent Card

Column							
1	2	3	4	5	6	7	8
5X	15	15	5X	F10.2	F10.2		
	a	b		c	d		Comments

- where
- a = component number
 - b = stage number
 - c = unit repair cost
 - d = unit inspection cost

4.3.4 Raw Material Costs

The basic components entering the manufacturing system are called raw materials. Their unit costs corresponding to qualities (p) are entered in this section. See descriptions of the cost functions in Section 4.4.

The general format is

Title Card

Column							
1	2	3	4	5	6	7	8
RAW MATERIAL COSTS							
							Comments

Subsequent Cards

Each component of the raw materials requires at least 2 cards to specify its coordinates. The first card identifies component number, types of cost functions and number of cost coordinates. Its format is:

Column	1	2	3	4	5	6	7	8
	1234567890	1234567890	1234567890	1234567890	1234567890	1234567890	1234567890	1234567890
Sx	15	15	15					
	a	b	c					Comments

where a = component number
 b = type of cost function (0,1,...,9)
 c = number of coordinates if the cost function is of type 0; otherwise leave blank.

Other cards following this card have the format:

Column	1	2	3	4	5	6	7	8
	1234567890	1234567890	1234567890	1234567890	1234567890	1234567890	1234567890	1234567890
10x	F5.3	F5.3	F5.3	F5.3	F5.3	F5.3	F5.3	
	*	*	*	*	*	*	*	Comments

*See section 4.4 for explanation of these fields.

4.3.5 Manufacturing Costs

Cost associated with the manufacturing stations are inputted through this section. The form of input is similar to that of RAW MATERIAL COSTS except that, in this case, we have to identify the component and the stage of the station.

Title Card

Column	1	2	3	4	5	6	7	8
	1234567890	1234567890	1234567890	1234567890	1234567890	1234567890	1234567890	1234567890
	MANUFACTURING COSTS							
								Comments

specified in the first card. The interpretations are as follows:

For a station or raw material, if the cost function is of type 0, then the number of coordinate pairs must be inputted in the first card. Subsequent card(s) will contain the coordinates. Five pairs of coordinates are allowed on each card. (See Section 4.4.1 for more.) If the cost function is one of the types 1,2,...,9, then only the next card will be considered as related to the station. The cost function parameters on this card will be used by SUBROUTINE CØSTFN to generate cost coordinates. (See Section 4.4.2 and 4.4.3.)

4.4.1 Type 0

When the cost data cannot be expressed in functional form or only a discrete set of alternatives are to be considered, the known coordinates are inputted directly. For example, if for Component #3 of the raw materials, we have a choice of 6 brands of the same kind of raw material, we can represent them by the cost function of Figure 4.5.

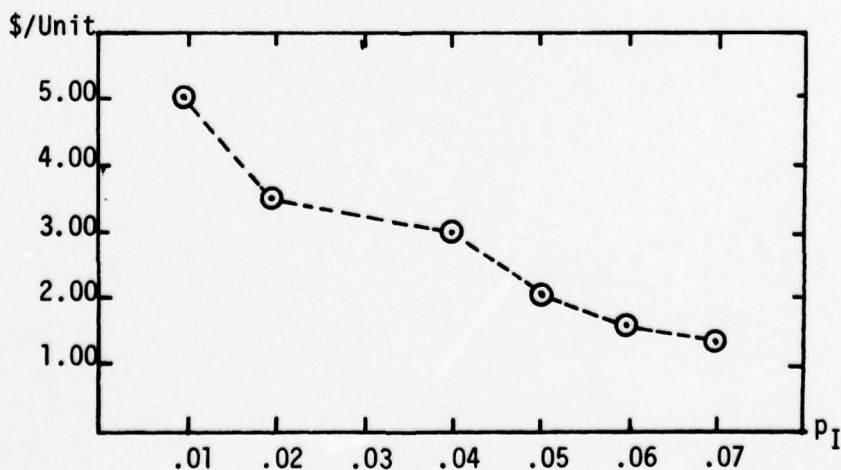

Figure 4.5 Sample Cost of Type 0

4.4.3 Type 2,3,...9

If the user wishes to use a functional form other than Type 1 and does not want to put all the cost coordinates in as for type 0, then the user may modify the subroutine CØSTFN to specify the user's functional form. Section 6.2 describes this. The user may specify up to 8 additional functional forms and call them Types 2 through 9.

If one of these types is specified, only one card containing the values of parameters for that functional form is input. Seven parameters, A(1), A(2),...,A(7), are allowed to be used in any of these cost functions. The format is:

Column	1	2	3	4	5	6	7	8			
12345678901234567890123456789012345678901234567890123456789012345678901234567890											
10X	F5.3	F5.3	F5.3	F5.3	F5.3	F5.3	F5.3				
	a	b	c	A(1)	A(2)	A(3)	A(4)	A(5)	A(6)	A(7)	Comments

where a = grid size of p
 b = lower bound of p
 c = upper bound of p

A(1),...,A(7) = constants to be used in SUBROUTINE CØSTFN.

SUBROUTINE CØSTFN, as supplied by the package, has the functional equation:

$$[\$/unit] = \frac{1}{p}$$

for types 2,3,...,9 but these are given only as examples. For example, to specify a different functional form for Type 2, the statement with statement number 2 in Subroutine CØSTFN would be changed to: 2 FN = "your functional form using up to 7 parameters and X is the quality level".

5.0 OUTPUT

This chapter provides the characteristics of the outputs as well as their interpretations. Two options of the outputs are given: namely, the complete output (intermediate output and summary output), and only the summary report table. Both are obtained through the variable NPRT in the main program. NPRT equals 1 if the former is desired, zero if the latter is desired. The default option is complete output. Section 5.1 gives the contents of the summary report table and Section 5.2 gives the contents of the complete output. The interpretation of the complete output and the diagram of the optimal solutions to an example problem are discussed in Sections 5.3 and 5.4.

5.1 Summary Report Table

As mentioned, when the user requests only the final solution, the main program must be modified to make the variable $NPRT = 0$. In effect, the summary report table is printed immediately after all input images and the program limitation indicators which are explained in Section 6.1.2.

The following discussion will illustrate the output for the example given in the Appendix. The input stream and the complete output are presented as an aid to the user.

The summary report table consists of sixteen columns, which provide the information needed for each station. The information is printed station by station first component to the last, starting with the last stage first and proceeding to the first.

The following gives the list of column headings.

Table 5.1 Column Headings - Summary Report

1	2	3	4	5	6	7	8	9
STATION NAME	STAGE	COMPO- NENT	TYPE OF STN	SAMPLING PLAN -- N -- C --	PROCESS FRAC. DEFECT	*STATE VARIABLE -- A0Q -- A0QL --		
	10	11	12	13	14	15	16	
	STATE VARIABLE -- P _I -- P _T --		STAGE COST	MINIMUM EXPECTED COST F	SUB OPT IND	ALT SOLN IND	REMARKS	

Table 5.2 indicates which columns are used for each type of station.

Table 5.2 Output Column Usage

COLUMN NUMBER	DESCRIPTION	Station type (x - required)			
		ASSEMBLY**		INSPEC- TION	MANUFAC- TURING
		First line (PR0D sub.)	the following lines (ASSMBY sub.)		
1	Station name	X		X	X
2	Stage number	X	X	X	X
3	Component number	X	X	X	X
4	Type of station	A	A	I	P
5	Sample size			X	
6	Acceptance number			X	
7	Process fraction defective	X			X
8	Average outgoing quality			X	
9	Average outgoing quality level			X	
10	Incoming quality	X	X	X	X
11	Process outgoing quality	X			X
12	Stage cost	X#		X#	X#
13	Minimum expected Cost (F*)	X		X	X
14	Suboptimal indicator	X	X	X	X
15	Alternative solution indicator	X	X		
16	Remarks	*	*		

** There are two types of information for each assembly station; because for every "m-component" assembly station, subroutine ASSMBY, (see Chapter 3, package overview and Appendix 1) is called (m-1) times in order to determine aggregate qualities then subroutine PRØD is finally called. Therefore, in total, m lines of information are recorded for each assembly station.

In the first stage and for any type of station, stage cost shown excludes the raw material costs. In other words, the raw material costs can be determined by subtracting stage cost from minimum expected cost (F*). The first stage of a component need not be an inspection station.

5.2 Complete Output

Besides the summary report table, the user may need the intermediate outputs of all state variable values, station by station, for all stages as well as three tables derived from the INSP1 subroutine, namely the average total inspection table, sample size table, and acceptance number table. The average total inspection table, the sample size and acceptance number tables are entered by the incoming quality and the average outgoing quality level values. The information will serve the user as a source for the conventional DP iterative solution trace back. This, in turn, enables the user to obtain the solutions manually for sensitivity analysis.

After the INSP1 output, the solution table of each station is printed, station by station, component by component, stage by stage, all starting from the first to the last. This will be followed by the summary output as described in Section 5.1. An inspection station or manufacturing station requires one table. In an "m-component" assembly type station, two types of tables are printed out. The first ones are called "aggregate incoming quality" tables and (m-1) tables of this kind are printed. The last table contains the same kind of information as a manufacturing station table and refers to

the additional defectives generated by the assembly. Therefore, for each assembly station, m tables are printed. All stations are identified by component number, stage number, station type and station name, (if any) in headings. Table 5.3 gives the information for an Inspection station, as conceptualized in Figure 2.1.

Table 5.3 Inspection Station Output

COLUMN NUMBER	VARIABLE	DESCRIPTION	REMARKS
1	AOQ	Average Outgoing Quality	$AOQ \leq AOQL$ State variable
2	AOQL	Average Outgoing Quality Limit	
3	N	Sample size "n"	Decision variable
4	C	Acceptance number "c"	Decision variable
5	PIY	Incoming Quality Level "p _I " (Optimum for AOQ)	State variable from previous stage
6	STAGE COST	Inspection and Repair Costs	Does not include raw material cost
7	F ₀	Minimum Average Cost Thus Far (f _n)	$f_n = f_{n-1} + \text{STAGE COST}$
8	KSI'S	Suboptimal Indicator	(see Section 5.4)

Table 5.4 gives the information generated for a Manufacturing station as conceptualized in Figure 2.2.

Table 5.5 shows the output for the $(m-1)$ tables for an m -component assembly station. Figure 5.1 illustrates the notion of this recursive aggregation of components.

In effect, Figure 5.1 shows the computer programming aspect which was discussed in Section 2.4. The ASSMBY subroutine is called $(m-1)$ times,

according to Figure 2.3, to determine recursively the minimum cost aggregate incoming quality for that assembly station. The first call on ASSMBY would treat $p_{I,1}$ as $PI1$ and $p_{I,2}$ as $PI2$, this results the values of PAI with the values of optimum $PI1$, $PIA1$ and optimum $PI2$, $PIA2$. These values are stored and printed in the first table (if complete output is desired). The second call on ASSMBY would treat PAI from the first table as $PI1$ and $p_{I,3}$ as $PI2$, the new values of PAI with the values of optimum of previous PAI , $PIA1$ and optimum $p_{I,3}$, $PIA2$. The calls continue in this manner $(m-1)$ times where the PAI from the $(m-1)$ st call represents the aggregate incoming quality for that assembly station.

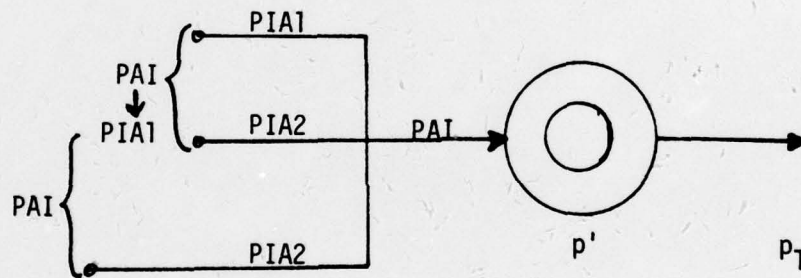

Figure 5.1 Assembly Station Quality Aggregation

Table 5.4 Manufacturing Station Output

COLUMN NUMBER	VARIABLE	DESCRIPTION	REMARKS
1	p_T	Average Outgoing Quality (p_T)	State variable
2	PIY	Average Incoming Quality (p_I) (Optimum for (p_T))	State variable from previous stage
3	PPY	Average Process Quality Level (p')	Decision variable
4	STAGE COST	Manufacturing Cost	Does not include raw material cost
5	$F\emptyset$	Minimum Average Cost Thus Far (f_n)	$f_n = f_{n-1} + \text{STAGE COST}$
6	LSUB	Suboptimal Indicator	(see Section 5.4)

Table 5.5 Assembly Station Quality Aggregation Output

COLUMN NUMBER	VARIABLE	DESCRIPTION	REMARKS
1	PAI	Aggregate Incoming Quality Level (p_{AI})	$PAI = PIA1 + PIA2 - PIA1*PIA2$
2	PIA1	(aggregate) incoming quality (optimum p_{AI} or $PI1$)	$PIA1 = PI1$ if the 1st tab = PAI of previous tab otherwise
3	PIA2	Average Incoming Quality (optimum $PI2$ for PAI)	State variable to the previous stage
4	FAI	Minimum Aggregate Cost	$FAI = FI1 + FI2$
5	ISUB	Alternative solution indicator	(see Section 5.4)

Table 5.6 shows the output generated by optimization with respect to p .

Table 5.6 Assembly Station Decision Variable Output

COLUMN NUMBER	VARIABLE	DESCRIPTION	REMARKS
1	PT	Average Outgoing Quality (p_T)	State variable
2	PIY	Average Incoming Quality (p_I) (optimum for PT)	$PIY (PT) = \text{opt. } (PAI) \text{ PPY}$
3	PPY	Average Process Quality Level (p')	Decision variable
4	STAGE COST	Assembly Cost	Does not include raw material cost
5	F \emptyset	Minimum average cost thus far (f_n)	$f_n = f_{n-1} + \text{STAGE COST}$
6	LSUB	Suboptimal Indicator	(see Section 5.4)

5.3 Interpretation of Outputs and An Example

This section will discuss the interpretation of the outputs and the manual traceback procedure. The example of Figure 5.2 will be used as an illustration. Appendix A contains the computer output for this problem. It also contains the input card images.

When the solutions for a specified final AOQL at the last station (always an inspection station) is required, the summary report table would be sufficient for the source of actions for the system. The cost shown on the first line of the 13th column represents the minimum average cost incurred for the entire system for that particular value of the final AOQL.

Whenever the user needs to know the average total inspection or desires to examine plans for final AOQL values other than that specified, the complete outputs must be called. The latter can be obtained by intermediate outputs, station by station and the basic knowledge of dynamic programming trace-back.

5.3.1 Manual Trace-Back Procedure

In effect, the summary report table can be obtained manually through the intermediate outputs, station by station. Fortunately, for a specified final AOQL, the program has a certain routine to perform a trace-back internally. In what follows, we will demonstrate how the user can obtain the solutions to other values of AOQL. We will describe the procedure using the example in Appendix A with $AOQL = 0.050$.

Before we proceed to the example, the procedure is recapitulated as follow :

1. It is advisable to have the structure of the system in front of the user to reduce ambiguities in connecting the stations and the components.

2. Start from the last stage and proceed toward the first stage.
3. Start from last table to the first for each station.
4. Finish all stations in that stage before proceeding.
5. Table 5.7 below summarizes the state variables used to connect stations.

Table 5.7 State Variables Names - By Stations

TYPE OF STATION	OUTGOING STATE VARIABLE	INCOMING STATE VARIABLE	REMARKS
Inspection	AOQ	PIY	
Manufacturing	PT	PIY	
"n-component"	PT	PIY	the n^{th} table
Assembly	PAI(PIY from n^{th} table) PAI(PIA1 from $(n-1)^{\text{st}}$ table) PAI(PIA1 from 2nd table)	PIA1 and PIA2* PIA1 and PIA2* PIA1* and PIA2*	the $(n-1)^{\text{st}}$ table the $(n-2)^{\text{nd}}$ table the 1st table

* These are the average incoming qualities p_I of the n^{th} component to the 1^{st} component entering to that particular "n-component" assembly station, respectively.

Figure 5.2 illustrates the structure of the system used, for an example: The final AOQL = 0.050.

The number above the line are the average quality values (optimum outgoing and incoming qualities).

Starting from the last table of the intermediate outputs, component #4, stage #5 which is the inspection station. The specified (system) average outgoing quality limit is 0.050 which yields the AOQ value of 0.049, $n = 71$, $c = 6$, and the required incoming quality (PIY) of 0.055.

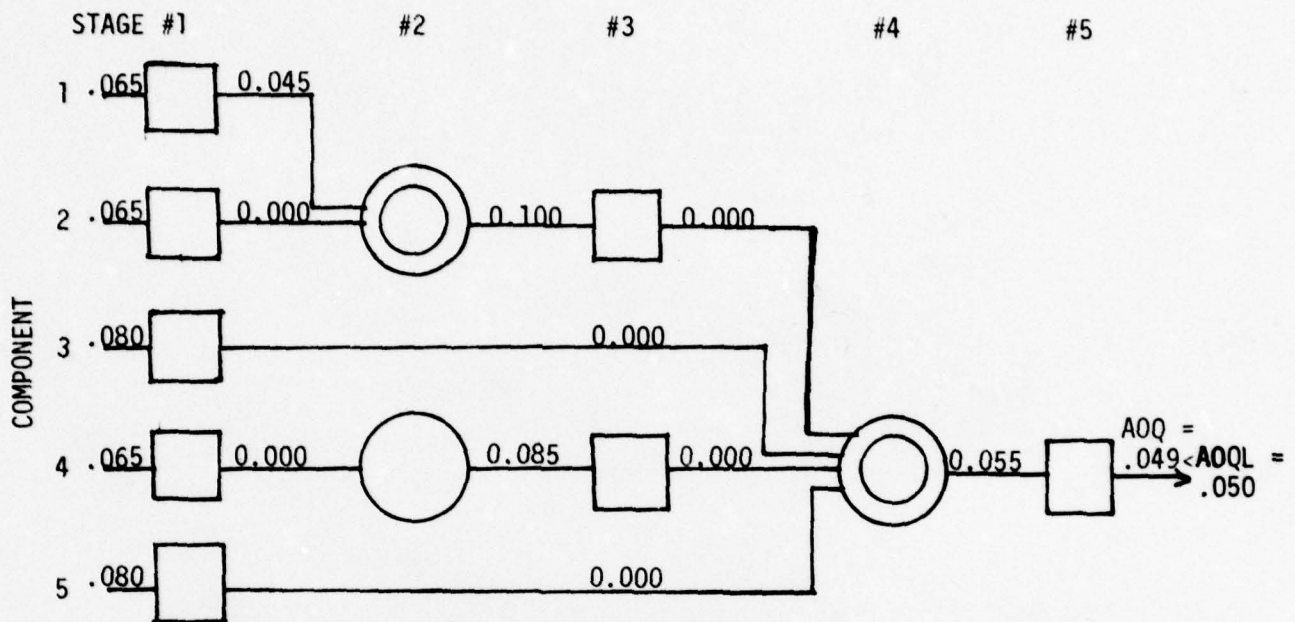

Figure 5.2 System Structure - An Example

In the table of the assembly station in Stage 4, the state variable used is PT (the average process outgoing quality) which is the PIY value obtained previously, i.e. 0.055. Consequently, the required average incoming quality (PIY) = 0.000 with PPY (the average process quality required) is 0.055.

In the table Component 5, Stage 4, the state variable for this table is PAI (the aggregate incoming quality) = 0.000. From PAI value, the PIA1 is 0.000 and the PIA2 is 0.000 which will be used as the state variable to the table of Component 5, Stage 1.

Entering table of Component 4, Stage 4 by the state variable PAI which is the value of PIA1 = 0.000 obtained previously, the PIA1 is now 0.000 and PIA2 is 0.000 which will be used as the state variable to the table of Component 4, Stage 3.

Again the latest PIA1 value, i.e. 0.000, is used for the state variable PAI of the table of Component 3, Stage 4. The new PIA1 is 0.000 and the PIA2 is 0.000. Since the present table is the first one for this assembly station (Component 4, Stage 4), the former value of 0.000 is the state variable AOQ value for the inspection station of Component 2, Stage 3. The later value of 0.000 is the state variable AOQ value for the inspection station of Component 3, Stage 1.

In the table of Component 4, Stage 3, an inspection station, the value of state variable (AOQ) is 0.000 obtained from the PIA2 value of the table of Component 4, Stage 4. The n and c values are 1000 and zero with PIY value (the required incoming quality level) equals 0.085.

In the table of Component 2, Stage 3, an inspection station, the value of AOQ is 0.000 obtained from the PIA1 value of the table of Component 4, Stage 4. The plan is $n = 1000$, $c = 0$, and the incoming quality level is 0.100 (PIY).

In the table of Component 4, Stage 2, a manufacturing station, the value of state variable P_T is 0.085 obtained from PIY value of table of Component 4, Stage 3. The required incoming quality level (PIY) = 0.000 and the average process average is 0.085.

In the assembly station in Stage 2, entering the table with the PIY value obtained from the table of Component 2, Stage 3 to the state variable P_T which is 0.100. The required incoming quality level (PIY) is 0.045 and the process quality level is 0.060.

Using the value of PIY obtained just above (0.045) as the state variable PAI of the table of Component 2, Stage 2, PIA1 and PIA2 values are 0.045 and 0.000. These values will be used as the state variable values (AOQ) for the tables of Component 1, Stage 1 and of Component 2 Stage 1,

respectively.

At Stage 1, all stations are inspection stations, we have already obtained the values of state variable AOQ for tables in Component 5 up to 1, which are 0.000, 0.000, 0.000, 0.000, and 0.045, respectively. The values of average incoming quality for raw materials are 0.065, 0.065, 0.080, 0.065 and 0.080, respectively.

Figure 5.3 gives the solution values to the system structure.

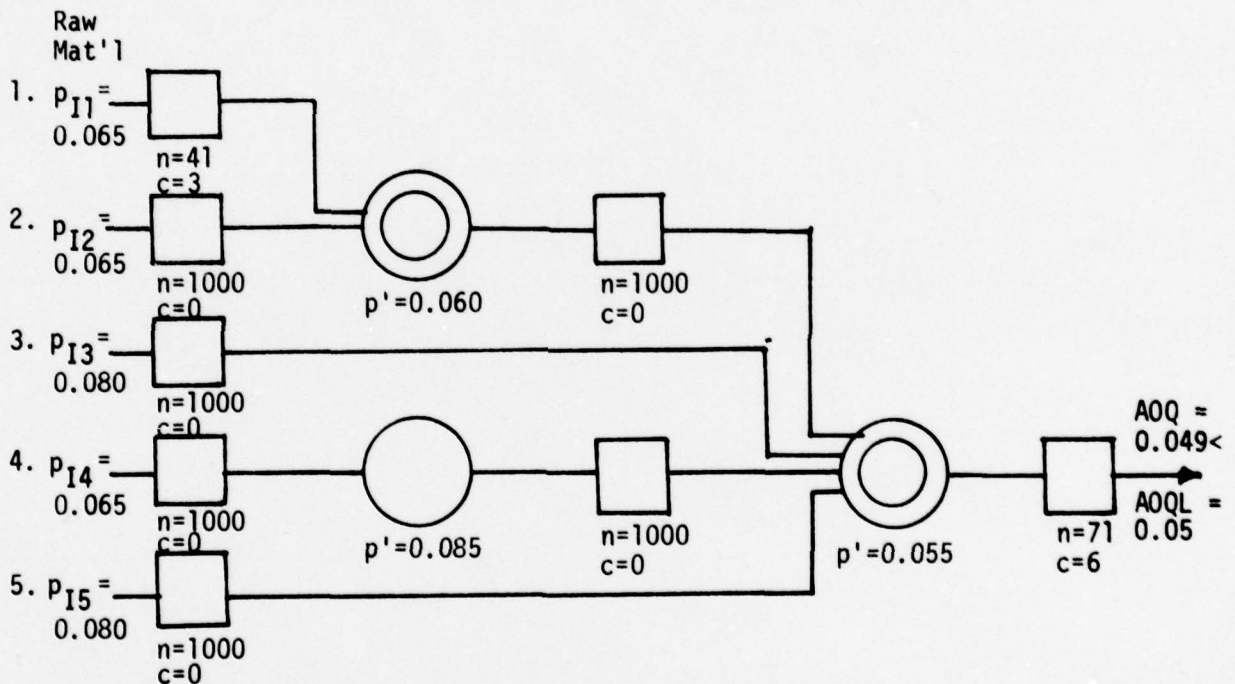

Figure 5.3 Solution to the Example

5.4 Suboptimal Conditions and Alternative Solutions

At any station there exists a suboptimal indicator variable for each value of the resulting quality. The indicator is 0, if, at that average outgoing quality, the value of decision variable is a global optimum; 1 if it is a "possible" local optimum. The variable is KSUB for inspection and LSUB for manufacturing or assembly. For an inspection station the sub-

optimal condition is caused when the average incoming quality, P_I , called for by the algorithm (see Chapter 2) is greater than the maximum average incoming quality, $P_{I \max}$ ¹ for that particular station. This means that the global optimum P_I^* might exist beyond the $P_{I \max}$ value, had the maximum average incoming quality been greater than the current $P_{I \max}$.

Another type of suboptimal indicator (ISUB), again zero or one, is involved in assembly stations where the ASSMBY subroutine is called for. In effect, the subroutine computes the aggregate incoming quality from a pair of components coming into assembly stations. ISUB equals 1 if an aggregate incoming quality formed by two sets of average incoming quality is greater than the maximum values of average incoming quality in either set, i.e.

$$PAI > \min [\max P_{I1}, \max P_{I2}]$$

Furthermore, the subroutine gives the indications of alternative solutions in the summary report table. The number indicates how many alternative combinations of P_{I1} and P_{I2} values the particular PAI has that yield the same incoming costs.

1 (see Ch. 3) $P_{I \max} = \begin{cases} P_{I \text{ raw}} & : \text{ No previous station} \\ AOQL \times FMAX & : \text{ otherwise} \end{cases}$

6.0 POSSIBLE MODIFICATIONS TO THE PROGRAM

The program package as supplied can be easily modified to accomodate bigger size problems and/or other cost functions. Larger problems are discussed in Section 6.1. Other functional forms for cost functions are discussed in Section 4.4.3. If the input data is on cards, see Section 6.2.

6.1 How to Accomodate a Larger Problem

By changing the dimensions of arrays and vectors in the MAIN program one can increase the size of the problem that the program can solve. Twelve parameters are used to control the amount of storage area required in the computer. They are indicated and defined in Table 6.1.

The listing of the MAIN program is in Appendix B. By altering the DIMENSION Statements in the MAIN program according to the appropriate parameters, the size of the problem that the program can handle is altered.

It is advised that for a large problem, the program should be run, first, by adjusting only the MAXCOM and MAXSTG parameters to fit the problem. The program will determine the proper sizes of the other parameters for adjustment in the next run. The reason behind this approach is because the task of estimating the sizes of the various parameters is a rather time-consuming process and the allocation of too big a storage may be too costly.

Table 6.1 Parameter Definitions

<u>Parameter</u>	<u>Definition</u>
MAXCØM	Maximum number of components
MAXSTG	Maximum number of stages
J1	Total # of cost coordinate pairs for all RAW MATERIAL CØSTS
J2	Maximum number of cost coordinate pairs for a station or a raw material component
J3	Total # of cost coordinate pairs for processing stations and assembly stations
J4	Total # of inspection stations
J5	Number of values of AØQL $\frac{(\text{FINAL AØQL}) * (\text{FMAX})}{\text{State Variable Grid Size}} + 1$
J6	Number of unique P_1 values used to generate tables of ATI N and C. Note: $J6 < J7$
J7	$J1 + J5$
J8	(# of components in the problem) * J5
J9	(Maximum # of components going into an assembly station) * J5
J10	Maximum of (J2, J6)

Other parameters that may need to be adjusted for input/output devices are in Table 6.2.

Table 6.2 Input/Output Device Parameters

<u>Parameter</u>	<u>Definition</u>
NRD	Input I/O-unit capable of rewinding
NWR	Output I/O-unit
NDS	I/O unit for random access file
NPRT	{ 1 full output desired { 0 partial output desired

6.2 Rewinding of Input Data File

As shown in Figure 4.1 (Schematic Diagram of Input/Output files),

it is required that the input data for a problem be put on a sequential data file which can be rewound by the program. The purpose of this feature is for the program to copy the data file image on the output for user verification, (see the example in Appendix A). The program rewinds the file and reads it again to interpret the data. It is possible to eliminate the rewinding step if one will sacrifice the printing of the input data image.

If the input data is on cards, the job control language associated with this program will be simplified if the rewinding step is eliminated. In order to accomplish this, statements with sequence numbers IPT 00039 to IPT 00050 (inclusive) of Subroutine INPUT must be deleted.

Note 1 The program as distributed will solve a system with up to 14 components and 15 stages.

Note 2 It took less than one minute of cpu plus I/O time to solve the example problem in Appendix A.

BIBLIOGRAPHY

- Hassan, M. Z. and Knowles T. W., "An Optimal Quality Control Design for a Single-Product Serial Manufacturing System", Journal of Quality Technology, Vol. 11, No. 1, January, 1979.
- Manaspiti, A., Semi-Economic Quality Systems Design for Multi-Product Manufacturing Environments Subject to Inspection Error, Unpublished Ph.D. Thesis, Illinois Institute of Technology, 1979.
- Subramaniam, R., Design of Economic Quality Assurance Systems of Inter-Related Single Sampling Plans Using Dynamic Programming, Unpublished Ph.D. Thesis, Illinois Institute of Technology, 1976.

APPENDIX A
AN EXAMPLE OF THE OUTPUTS

DEPARTMENT OF MANAGEMENT SCIENCES * * * ILLINOIS INSTITUTE OF TECHNOLOGY

DESIGN OF MANUFACTURING QUALITY SYSTEM *

DESIGN OF INCOMING QUALITY LEVEL, PROCESS QUALITY LEVEL AND OPTIMAL INTERRELATED SINGLE SAMPLING PLANS FOR THE TOTAL MANUFACTURING SYSTEM. THIS WORK WAS PARTIALLY SUPPORTED BY THE OFFICE OF NAVAL RESEARCH UNDER CONTRACT NUMBER N00014-76-C-0801

DATA FILE IMAGE FOR THIS RUN

46

CARD NUMBER	CARD IMAGE	1	2	3	4	5	6	7	8
1	QUALITY CHARACTERISTICS	1234567890123456789012345678901234567890123456789012345678901234567890							
2	STRUCTURE	.050	.005	2.00	1000				
3		1	11	2AONE					
4		2	11	2AONE	31	4ATWO			
5		3	11	4ATWO					
6		4	11	2M	31	4ATWO	51		
7		5	11	4ATWO					
8	INSPECTION COSTS	1	1	9.00	0.45				
9		2	1	7.50	0.25				
10		3	1	9.00	0.45				
11		4	1	7.50	0.25				
12		5	3	10.00	0.50				
13		6	3	13.00	0.50				
14		7	4	19.00	4.00				
15		8	5	9.00	0.45				
16	RAW MATERIAL COSTS	1	1	.005	.100	0.06	12.		
17		2	1	.005	.100	0.03	9.		
18		3	1	.005	.100	0.06	10.		
19		4	1	.005	.100	0.03	10.		
20		5	1	.005	.100	0.03	10.		
21		6	1	.005	.100	0.03	10.		
22		7	1	.005	.100	0.03	10.		
23		8	1	.005	.100	0.03	10.		
24		9	1	.005	.100	0.03	10.		
25		10	1	.005	.100	0.03	10.		
26		11	1	.005	.100	0.03	10.		

27	5	1							TEST DATA FILE
28		.005	.005	.100	0.06	1.0			TEST DATA FILE
29	ASSEMBLY COSTS								
30	2	2	1						TEST DATA FILE
31		.005	.005	.100	0.07	3.0			TEST DATA FILE
32	4	4	1						TEST DATA FILE
33		.005	.005	.100	0.10	5.0			TEST DATA FILE
34	MANUFACTURING COSTS								
35	4	2	1						TEST DATA FILE
36		.005	.005	.100	0.09	4.5			TEST DATA FILE
37	ENDATA								
									TEST DATA FILE

DEPARTMENT OF MANAGEMENT SCIENCES * * * ILLINOIS INSTITUTE OF TECHNOLOGY

* * * DESCRIPTIONS OF PROBLEM * * *

FINAL AOGL .050
STATE-VARIABLE GRID SIZE .005
FMAX 2.000
LOT SIZE 1000

* * * STRUCTURE OF PROBLEM * * *

STAGE	1	2	3	4	5
COMPONENT					
1	I	AONE			
2	I	AONE	I	ATMO	
3	I			ATMO	
4	I	M	I	ATMO	I
5	I			ATMO	

DEPARTMENT OF MANAGEMENT SCIENCES * * * ILLINOIS INSTITUTE OF TECHNOLOGY

 * NUMBER OF UNIQUE STATIONS IN ASSEMBLY CHART *

STATION TYPE	A	I	M	TOTAL
	2	8	1	11

*** NUMBER OF COMPONENTS = 5
 *** NUMBER OF STAGES = 5
 *** % DENSITY OF CHART = 44.00

 * SPECIFIED PARAMETERS *

	MAXCOM	MAXSTG	J1	J2	J3	J4	J5	J6	J7	J8	J9	J10
LIMIT OF PROGRAM	15	14	180	35	200	25	25	50	205	150	105	50
ACTUAL PROBLEM	5	5	100	20	60	8	21	21	121	105	84	21

DEPARTMENT OF MANAGEMENT SCIENCES * * * ILLINOIS INSTITUTE OF TECHNOLOGY

AVERAGE TOTAL INSPECTION TABLE ... ATI(A00, PI) *

	PI														
	.000	.005	.010	.015	.020	.025	.030	.035	.040	.045	.050	.055	.060	.065	.070
A00	.075	.080	.085	.090	.095	.100									
.000	1000.0	1000.0	1000.0	1000.0	1000.0	1000.0	1000.0	1000.0	1000.0	1000.0	1000.0	1000.0	1000.0	1000.0	1000.0
.005	501.0	667.6	750.5	800.9	834.3	857.3	875.3	889.4	900.8	910.1	917.4	923.8	928.7		
.010	933.8	937.9	941.5	944.7	948.0	950.6									
.015	867.1	875.7	883.0	889.4	895.1	900.2									
.020	800.9	813.1	824.5	834.2	842.3	850.7									
.025	734.3	750.1	765.4	778.2	789.5	800.5									
.030	666.7	688.2	705.9	722.5	737.8	750.1									
.035	600.3	625.2	648.0	667.3	684.6	700.0									
.040	534.1	562.7	588.4	612.1	632.2	650.2									
.045	467.2	500.2	530.1	556.0	579.2	600.6									
.050	400.9	438.3	470.7	500.4	526.8	550.9									
.055	334.2	375.7	412.3	444.5	474.1	500.2									
.060	267.6	313.2	353.7	389.2	421.2	450.5									
.065	200.9	250.6	294.2	334.1	368.5	400.2									
.070	134.3	186.2	235.3	278.3	316.3	350.7									
.075	66.7	125.1	176.8	222.3	263.6	299.9									
.080	62.8	117.9	167.2	211.0	250.4										
.085	59.0	111.9	158.3	200.6											
.090	55.7	105.5	150.5												
.095	53.0	100.1													
.100	50.2														

DEPARTMENT OF MANAGEMENT SCIENCES * * * ILLINOIS INSTITUTE OF TECHNOLOGY

 * SAMPLE SIZE TABLE ... N(A00, PI) *

	.000		.005		.010		.015		.020		.025		.030		.035		.040		.045		.050		.055		.060		.065		.070	
PI	1000	1000	1000	1000	1000	1000	1000	1000	1000	1000	1000	1000	1000	1000	1000	1000	1000	1000	1000	1000	1000	1000	1000	1000	1000	1000	1000	1000	1000	1000
A00	.000	1000	1000	1000	1000	1000	1000	1000	1000	1000	1000	1000	1000	1000	1000	1000	1000	1000	1000	1000	1000	1000	1000	1000	1000	1000	1000	1000	1000	1000
	.005	0	0	63	202	66	62	183	131	181	26A	76	43	91	39	223														
	.010	0	0	91	33	83	94	47	115	174	131	65	3A1	129	100	152	244	85												
	.015	0	0	108	131	151	120	91	145	365	370	77	185	232	200	101	96	169												
	.020	0	0	112	246	90	74	95	182	181	174	40	18	251	222	150	83													
	.025	0	0	48	162	58	56	154	61	111	189	52	70	264	146	79	76													
	.030	0	0	185	68	247	109	188	0	81	58	224	12A	171	105	130	125													
	.035	0	0	26	51	73	125	79	0	0	93	95	171	237	67	363	104													
51	.040	0	0	73	94	46	181	75	0	0	0	0	98	145	59	99	46													
	.045	0	0	160	292	97	194	140	0	0	0	0	0	31	130	102	41	171												
	.050	0	0	163	84	203	332	116	0	0	0	0	0	56	3	125	19A													
	.055	0	0	224	100	176	66	55	0	0	0	0	0	0	0	42	60	12												
	.060	0	0	259	124	83	209	15	0	0	0	0	0	0	0	0	36													
	.065	0	0	40	31	97	249	120	0	0	0	0	0	0	0	0	0	35												
	.070	0	0	170	19	160	73	220	0	0	0	0	0	0	0	0	0													
	.075	0	0	114	58	34	102	35	0	0	0	0	0	0	0	0	0													
	.080	0	0	36	58	15	103	88	0	0	0	0	0	0	0	0	0													
	.085	0	0	0	0	49	19	58	37	0	0	0	0	0	0	0	0													
	.090	0	0	0	0	0	20	91	134	0	0	0	0	0	0	0	0													
	.095	0	0	0	0	0	0	47	54	0	0	0	0	0	0	0	0													
	.100	0	0	0	0	0	0	37	0	0	0	0	0	0	0	0	0													

DEPARTMENT OF MANAGEMENT SCIENCES * * * ILLINOIS INSTITUTE OF TECHNOLOGY

 * COMPONENT 1 STAGE 1 STATION TYPE I STATION NAME , * *

AQU	N	C	PIY	STAGE COST	FO	KSUB
.000	1000	0	.080	1170.00	13920.00	0
.005	91	3	.080	1097.37	13847.37	0
.010	108	5	.080	1024.55	13774.55	0
.015	132	7	.075	901.03	13701.03	0
.020	295	20	.075	826.11	13626.11	0
.025	244	17	.075	750.08	13550.08	0
.030	125	8	.070	617.88	13475.02	0
.035	104	7	.070	540.94	13398.08	0
.040	46	3	.070	463.80	13320.94	0
.045	41	3	.065	318.57	13241.65	0
.050	125	11	.065	239.10	13162.18	0
.055	42	5	.060	82.71	13082.71	0
.060	0	0	.060	.00	13000.00	0
.065	0	0	.065	.00	12923.08	0
.070	0	0	.070	.00	12857.14	0
.075	0	0	.075	.00	12800.00	0
.080	0	0	.080	.00	12750.00	0
.085	0	0	.085	.00	12705.88	0
.090	0	0	.090	.00	12666.67	0
.095	0	0	.095	.00	12631.58	0
.100	0	0	.100	.00	12600.00	0

DEPARTMENT OF MANAGEMENT SCIENCES * * * ILLINOIS INSTITUTE OF TECHNOLOGY

 * COMPONENT 2 STAGE 1 STATION TYPE I STATION NAME * * *

AUG	N	C	PIY	STAGE COST	FO	KSUB
.000	1000	0	.065	737.50	10199.04	0
.005	91	2	.060	642.17	10142.17	0
.010	152	6	.060	583.61	10083.61	0
.015	101	4	.060	525.62	10025.62	0
.020	222	12	.060	466.70	9966.70	0
.025	264	15	.055	361.59	9907.04	0
.030	171	10	.055	301.65	9847.11	0
.035	237	16	.055	241.45	9786.90	0
.040	145	11	.050	125.61	9725.60	0
.045	31	3	.050	63.02	9663.02	0
.050	0	0	.050	.00	9600.00	0
.055	0	0	.055	.00	9545.45	0
.060	0	0	.060	.00	9500.00	0
.065	0	0	.065	.00	9461.54	0
.070	0	0	.070	.00	9428.57	0
.075	0	0	.075	.00	9400.00	0
.080	0	0	.080	.00	9375.00	0
.085	0	0	.085	.00	9352.94	0
.090	0	0	.090	.00	9333.33	0
.095	0	0	.095	.00	9315.79	0
.100	0	0	.100	.00	9300.00	0

DEPARTMENT OF MANAGEMENT SCIENCES * * * ILLINOIS INSTITUTE OF TECHNOLOGY

 * COMPONENT 3 STAGE 1 STATION TYPE I STATION NAME , * *

AOU	N	C	PIV	STAGE COST	FO	KSUB
.000	1000	0	.080	1170.00	11920.00	0
.005	91	3	.080	1097.37	11847.37	0
.010	108	5	.080	1024.55	11774.55	0
.015	132	7	.075	901.03	11701.03	0
.020	295	20	.075	826.11	11626.11	0
.025	244	17	.075	750.08	11550.08	0
.030	125	8	.070	617.88	11475.02	0
.035	104	7	.070	540.94	11398.08	0
.040	46	3	.070	463.80	11320.94	0
.045	41	3	.065	318.57	11241.65	0
.050	125	11	.065	239.10	11162.18	0
.055	42	5	.060	82.71	11082.71	0
.060	0	0	.060	.00	11000.00	0
.065	0	0	.065	.00	10923.08	0
.070	0	0	.070	.00	10857.14	0
.075	0	0	.075	.00	10800.00	0
.080	0	0	.080	.00	10750.00	0
.085	0	0	.085	.00	10705.88	0
.090	0	0	.090	.00	10666.67	0
.095	0	0	.095	.00	10631.58	0
.100	0	0	.100	.00	10500.00	0

DEPARTMENT OF MANAGEMENT SCIENCES * * * ILLINOIS INSTITUTE OF TECHNOLOGY

 * COMPONENT 4 STAGE 1 STATION TYPE 1 STATION NAME ' ' *
 * *****

AOW	N	C	PIV	STAGE COST	FO	KSUB
.000	1000	0	.065	737.50	11199.04	0
.005	91	2	.060	642.17	11142.17	0
.010	152	6	.060	583.61	11083.61	0
.015	101	4	.060	525.62	11025.62	0
.020	222	12	.060	466.70	10966.70	0
.025	264	15	.055	361.59	10907.04	0
.030	171	10	.055	301.65	10847.11	0
.035	237	16	.055	241.45	10786.90	0
.040	145	11	.050	125.61	10725.60	0
.045	31	3	.050	63.02	10663.02	0
.050	0	0	.050	.00	10600.00	0
.055	0	0	.055	.00	10545.45	0
.060	0	0	.060	.00	10500.00	0
.065	0	0	.065	.00	10461.54	0
.070	0	0	.070	.00	10428.57	0
.075	0	0	.075	.00	10400.00	0
.080	0	0	.080	.00	10375.00	0
.085	0	0	.085	.00	10352.94	0
.090	0	0	.090	.00	10333.33	0
.095	0	0	.095	.00	10315.79	0
.100	0	0	.100	.00	10300.00	0

DEPARTMENT OF MANAGEMENT SCIENCES * * * ILLINOIS INSTITUTE OF TECHNOLOGY

 * COMPONENT 5 STAGE 1 STATION TYPE I STATION NAME ' * * *
 *

AOU	N	C	PIV	STAGE COST	FO	KSUB
.000	1000	0	.080	1170.00	11920.00	0
.005	91	3	.080	1097.37	11847.37	0
.010	108	5	.080	1024.55	11774.55	0
.015	132	7	.075	901.03	11701.03	0
.020	295	20	.075	826.11	11626.11	0
.025	244	17	.075	750.08	11550.08	0
.030	125	8	.070	617.88	11475.02	0
.035	104	7	.070	540.94	11398.08	0
.040	46	3	.070	463.80	11320.94	0
.045	41	3	.065	318.57	11241.65	0
.050	125	11	.065	239.10	11162.18	0
.055	42	5	.060	82.71	11082.71	0
.060	0	0	.060	.00	11000.00	0
.065	0	0	.065	.00	10923.08	0
.070	0	0	.070	.00	10857.14	0
.075	0	0	.075	.00	10800.00	0
.080	0	0	.080	.00	10750.00	0
.085	0	0	.085	.00	10705.88	0
.090	0	0	.090	.00	10666.67	0
.095	0	0	.095	.00	10631.58	0
.100	0	0	.100	.00	10600.00	0

DEPARTMENT OF MANAGEMENT SCIENCES * * * ILLINOIS INSTITUTE OF TECHNOLOGY

 * COMPONENT 2 STAGE 2 STATION TYPE A STATION NAME 'ONE' *

PAI	PIA1	PIA2	FAI	ISUB
.000	.000	.000	24119.04	0
.005	.005	.000	24046.41	0
.010	.010	.000	23973.59	0
.015	.015	.000	23900.06	0
.020	.020	.000	23825.14	0
.025	.025	.000	23749.12	0
.030	.030	.000	23674.06	0
.035	.035	.000	23597.12	0
.040	.040	.000	23519.98	0
.045	.045	.000	23440.69	0
.050	.050	.000	23361.21	0
.055	.055	.000	23281.75	0
.060	.060	.000	23199.04	0
.065	.065	.000	23122.11	0
.070	.070	.000	23056.18	0
.075	.075	.000	22999.04	0
.080	.070	.010	22940.76	0
.085	.070	.015	22882.76	0
.090	.070	.020	22823.84	0
.095	.050	.050	22762.18	0
.100	.065	.040	22646.68	1
.105	.070	.040	22582.75	1
.110	.070	.045	22520.17	1
.115	.070	.050	22457.14	1
.120	.075	.050	22400.00	1
.125	.075	.055	22345.45	1
.130	.080	.055	22295.45	1
.135	.080	.060	22250.00	1
.140	.085	.060	22205.88	1
.145	.090	.060	22166.67	1
.150	.090	.065	22120.20	1
.155	.095	.065	22093.12	1
.160	.095	.070	22060.15	1
.165	.100	.075	22000.00	1
.170	.100	.080	21975.00	1
.175	.100	.085	21952.94	1
.180	.100	.090	21933.33	1
.185	.100	.095	21915.79	1
.190	.100	.100	21900.00	1

DEPARTMENT OF MANAGEMENT SCIENCES * * * ILLINOIS INSTITUTE OF TECHNOLOGY

 * ASSEMBLY STATION - AGGREGATE SOLUTION TABLE *
 * STAGE 2 STATION NAME 'ONE' *

PT	PIY	PPY	STAGE COST	FB	LSUB
.000	.000	.000	*****	*****	0
.005	.000	.005	17000.00	41119.04	0
.010	.000	.010	10000.00	34119.04	0
.015	.000	.015	7666.67	31785.70	0
.020	.000	.020	6500.00	30619.04	0
.025	.000	.025	5800.00	29919.04	0
.030	.000	.030	5333.33	29452.37	0
.035	.000	.035	5000.00	29119.04	0
.040	.000	.040	4750.00	28869.04	0
.045	.000	.045	4555.56	28674.59	0
.050	.000	.050	4400.00	28519.04	0
.055	.000	.055	4272.73	28391.77	0
.060	.000	.060	4166.67	28285.70	0
.065	.000	.065	4076.92	28195.96	0
.070	.000	.070	4000.00	28119.04	0
.075	.005	.070	4000.00	28046.41	0
.080	.010	.070	4000.00	27973.59	0
.085	.015	.070	4000.00	27900.06	0
.090	.020	.070	4000.00	27825.14	0
.095	.025	.070	4000.00	27749.12	0
.100	.045	.060	4166.67	27607.35	0

DEPARTMENT OF MANAGEMENT SCIENCES * * * ILLINOIS INSTITUTE OF TECHNOLOGY

 * COMPONENT 4 STAGE 2 STATION TYPE M STATION NAME ' ' *
 *

PT	PIY	PPY	STAGE COST	FO	L SUB
.000	.000	.000	*****	*****	0
.005	.005	.005	22500.00	33699.04	0
.010	.010	.010	13500.00	24699.04	0
.015	.015	.015	10500.00	21699.04	0
.020	.020	.020	9000.00	20199.04	0
.025	.025	.025	8100.00	19299.04	0
.030	.030	.030	7500.00	18699.04	0
.035	.035	.035	7071.43	18270.47	0
.040	.040	.040	6750.00	17949.04	0
.045	.045	.045	6500.00	17699.04	0
.050	.050	.050	6300.00	17499.04	0
.055	.055	.055	6136.36	17335.40	0
.060	.060	.060	6000.00	17199.04	0
.065	.065	.065	5884.62	17083.65	0
.070	.070	.070	5785.71	16984.75	0
.075	.075	.075	5700.00	16899.04	0
.080	.080	.080	5625.00	16824.04	0
.085	.085	.085	5558.82	16757.86	0
.090	.090	.090	5500.00	16699.04	0
.095	.095	.095	5500.00	16642.17	0
.100	.100	.100	5500.00	16583.61	0

DEPARTMENT OF MANAGEMENT SCIENCES * * * ILLINOIS INSTITUTE OF TECHNOLOGY

 * COMPONENT 2 STAGE 3 STATION TYPE I STATION NAME ' ' *
 *

AOW	N	C	PIY	STAGE COST	FO	KSUB
.000	1000	0	.100	1500.00	29107.35	1
.005	47	1	.100	1425.89	29033.25	1
.010	91	5	.100	1350.35	28957.71	1
.015	95	6	.100	1276.08	28883.44	1
.020	154	12	.100	1200.77	28808.12	1
.025	188	16	.100	1125.19	28732.55	1
.030	79	6	.100	1049.99	28657.34	1
.035	75	6	.100	975.31	28582.67	1
.040	140	13	.100	900.86	28508.22	1
.045	116	11	.100	826.37	28433.72	1
.050	55	5	.100	750.26	28357.61	1
.055	15	1	.100	675.81	28283.17	1
.060	120	13	.100	600.37	28207.73	1
.065	220	26	.100	526.07	28133.42	1
.070	35	4	.100	449.92	28057.27	1
.075	88	11	.100	375.54	27982.90	1
.080	37	5	.100	300.94	27908.29	1
.085	134	21	.100	225.71	27833.06	1
.090	54	9	.100	150.18	27757.54	1
.095	37	8	.100	75.29	27682.65	0
.100	0	0	.100	.00	27607.35	0

61

DEPARTMENT OF MANAGEMENT SCIENCES * * * ILLINOIS INSTITUTE OF TECHNOLOGY

 * COMPONENT 4 STAGE 3 STATION TYPE I STATION NAME * * *

AOQ	N	C	PIY	STAGE COST	FO	KSUB
.000	1000	0	.085	1605.00	18362.86	0
.005	91	3	.080	1444.41	18268.45	0
.010	108	5	.080	1345.56	18172.60	0
.015	112	6	.080	1252.21	18076.25	0
.020	48	2	.080	1155.16	17979.20	0
.025	244	17	.075	983.44	17882.48	0
.030	133	9	.075	885.38	17784.42	0
.035	86	6	.075	787.82	17686.86	0
.040	142	11	.075	689.13	17588.17	0
.045	171	14	.070	504.42	17489.18	0
.050	198	18	.070	403.29	17388.04	0
.055	12	1	.070	303.41	17288.16	0
.060	36	4	.070	202.33	17187.08	0
.065	0	0	.065	.00	17083.65	0
.070	0	0	.070	.00	16984.75	0
.075	0	0	.075	.00	16899.04	0
.080	0	0	.080	.00	16824.04	0
.085	0	0	.085	.00	16757.86	0
.090	0	0	.090	.00	16699.04	0
.095	0	0	.095	.00	16642.17	0
.100	0	0	.100	.00	16583.61	0

DEPARTMENT OF MANAGEMENT SCIENCES * * * ILLINOIS INSTITUTE OF TECHNOLOGY

 * COMPONENT 3 STAGE 4 STATION TYPE A STATION NAME 'TWO ' *
 *

PAI	PIA1	PIA2	FAI	ISUB
.000	.000	.000	41027.35	0
.005	.005	.000	40953.24	0
.010	.010	.000	40877.71	0
.015	.015	.000	40803.44	0
.020	.020	.000	40728.12	0
.025	.025	.000	40652.55	0
.030	.030	.000	40577.34	0
.035	.035	.000	40502.67	0
.040	.040	.000	40428.22	0
.045	.045	.045	40349.00	0
.050	.000	.050	40269.53	0
.055	.000	.055	40190.07	0
.060	.000	.060	40107.35	0
.065	.000	.065	40030.43	0
.070	.005	.065	39956.32	0
.075	.010	.065	39880.79	0
.080	.015	.065	39806.51	0
.085	.020	.065	39731.20	0
.090	.025	.065	39655.62	0
.095	.050	.050	39519.79	0
.100	.040	.065	39431.29	1
.105	.045	.065	39356.80	1
.110	.050	.065	39280.69	1
.115	.055	.065	39206.24	1
.120	.060	.065	39130.80	1
.125	.065	.065	39056.50	1
.130	.070	.065	38980.35	1
.135	.075	.065	38905.98	1
.140	.080	.065	38831.37	1
.145	.085	.065	38756.14	1
.150	.090	.065	38680.61	1
.155	.095	.065	38605.73	1
.160	.100	.065	38530.43	1
.165	.100	.075	38407.35	1
.170	.100	.080	38357.35	1
.175	.100	.085	38313.24	1
.180	.100	.090	38274.02	1
.185	.100	.095	38238.93	1
.190	.100	.100	38207.35	1

DEPARTMENT OF MANAGEMENT SCIENCES * * * ILLINOIS INSTITUTE OF TECHNOLOGY

 * COMPONENT * STAGE * STATION TYPE A STATION NAME * TWO * *

PIA1	PIA2	FAI	ISUB
.000	.000	59390.22	0
.005	.005	59295.80	0
.010	.010	59199.95	0
.015	.015	59103.60	0
.020	.020	59006.55	0
.025	.025	58909.83	0
.030	.030	58811.78	0
.035	.035	58714.21	0
.040	.040	58615.52	0
.045	.045	58516.53	0
.050	.050	58415.40	0
.055	.055	58315.52	0
.060	.060	58214.44	0
.065	.065	58111.01	0
.070	.070	58012.11	0
.075	.075	57926.39	0
.080	.080	57851.39	0
.085	.075	57776.75	0
.090	.080	57701.73	0
.095	.075	57627.16	0
.100	.065	57511.87	1
.105	.075	57401.70	1
.110	.080	57326.70	1
.115	.075	57248.04	1
.120	.075	57168.57	1
.125	.075	57089.11	1
.130	.075	57006.39	1
.135	.075	56929.47	1
.140	.080	56854.47	1
.145	.075	56779.82	1
.150	.080	56704.82	1
.155	.065	56603.44	1
.160	.070	56504.54	1
.165	.075	56330.33	1
.170	.080	56255.33	1
.175	.075	56179.73	1
.180	.080	56104.73	1
.185	.075	56029.84	1
.190	.080	55954.84	1
.195	.075	55879.39	1
.200	.080	55804.39	1
.205	.080	55730.01	1
.210	.100	55650.11	1
.215	.090	55530.41	1
.220	.085	55436.48	1

DEPARTMENT OF MANAGEMENT SCIENCES * * * ILLINOIS INSTITUTE OF TECHNOLOGY

 * COMPONENT 3 STAGE 4 STATION TYPE A STATION NAME *TWO * *

PAI	PIA1	PIA2	FAI	ISUB
.000	.000	.000	71310.21	0
.005	.005	.000	71215.80	0
.010	.010	.000	71119.95	0
.015	.015	.000	71023.60	0
.020	.020	.000	70926.55	0
.025	.025	.000	70829.83	0
.030	.030	.000	70731.77	0
.035	.035	.000	70634.21	0
.040	.040	.000	70535.52	0
.045	.045	.000	70436.53	0
.050	.050	.000	70335.39	0
.055	.055	.000	70235.52	0
.060	.060	.000	70134.43	0
.065	.065	.000	70031.01	0
.070	.070	.000	69932.11	0
.075	.075	.000	69846.39	0
.080	.080	.000	69771.39	0
.085	.085	.000	69696.75	0
.090	.090	.000	69621.75	0
.095	.095	.000	69547.16	0
.100	.100	.000	69431.87	1
.105	.105	.000	69321.70	1
.110	.110	.000	69246.70	1
.115	.115	.000	69166.04	1
.120	.120	.025	69061.95	1
.125	.125	.025	68951.78	1
.130	.130	.030	68876.72	1
.135	.135	.025	68798.12	1
.140	.140	.025	68718.65	1
.145	.145	.020	68632.50	1
.150	.150	.020	68555.97	1
.155	.155	.025	68479.55	1
.160	.160	.060	68401.70	1
.165	.165	.000	68250.33	1
.170	.170	.000	68175.33	1
.175	.175	.065	68091.64	1
.180	.170	.015	67956.96	1
.185	.165	.025	67880.41	1
.190	.185	.030	67805.95	1
.195	.165	.035	67728.41	1
.200	.165	.040	67651.27	1
.205	.165	.050	67492.51	1
.210	.165	.055	67413.04	1
.215	.165	.060	67330.33	1
.220	.165	.065	67253.41	1

DEPARTMENT OF MANAGEMENT SCIENCES * * * ILLINOIS INSTITUTE OF TECHNOLOGY

 * ASSEMBLY STATION - AGGREGATE SOLUTION TABLE *
 * STAGE 4 STATION NAME 'TWO' *

PT	PIY	PPY	STAGE COST	F0	LSUB
.000	.000	.000	25000.00	96310.21	0
.005	.000	.005	15000.00	86310.21	0
.010	.000	.010	11666.67	82976.88	0
.015	.000	.015	10000.00	81310.21	0
.020	.000	.020	9000.00	80310.21	0
.025	.000	.025	8333.33	79643.55	0
.030	.000	.030	7857.14	79167.36	0
.035	.000	.035	7500.00	78810.21	0
.040	.000	.040	7222.22	78532.44	0
.045	.000	.045	7000.00	78310.21	0
.050	.000	.050	6818.18	78128.40	0
.055	.000	.055	6666.67	77976.88	0
.060	.000	.060	6538.46	77848.68	0
.065	.000	.065	6428.57	77738.79	0
.070	.000	.070	6333.33	77643.55	0
.075	.000	.075	6285.57	77548.52	0
.080	.010	.070	6428.57	77452.17	0
.085	.015	.070	6428.57	77355.12	0
.090	.020	.070	6428.57	77258.40	0
.095	.025	.070	6428.57	77163.20	0
.100	.045	.060	6666.67		0

DEPARTMENT OF MANAGEMENT SCIENCES * * * ILLINOIS INSTITUTE OF TECHNOLOGY

 * COMPONENT 4 STAGE 5 STATION TYPE I STATION NAME ' ' *
 *

AOJL	AOJ	N	C	PIY	STAGE COST	FO	KSUB
.000	.000	1000	0	.100	5900.00	83003.19	1
.005	.000	69	0	.100	5894.46	82997.66	1
.010	.004	36	0	.045	3928.79	82461.23	0
.015	.011	24	0	.045	3245.83	81778.27	0
.020	.018	137	5	.030	1542.22	81185.77	0
.025	.024	152	7	.035	1377.07	80544.42	0
.030	.028	130	7	.040	1261.01	80071.22	0
.035	.034	99	6	.040	928.20	79738.41	0
.040	.039	114	8	.050	1105.41	79415.63	0
.045	.044	66	5	.050	868.20	79178.41	0
.050	.049	71	6	.055	831.62	78960.02	0
.055	.055	65	6	.055	663.90	78792.30	0
.060	.059	79	8	.065	786.09	78634.76	0
.065	.064	74	8	.065	660.77	78509.44	0
.070	.068	52	6	.065	552.28	78400.96	0
.075	.075	57	7	.070	557.84	78296.62	0
.080	.076	53	7	.075	542.65	78186.19	0
.085	.082	50	7	.085	640.44	78092.61	0
.090	.085	61	9	.100	863.94	77967.13	1
.095	.087	45	7	.100	753.37	77856.57	1
.100	.089	49	8	.100	635.64	77738.83	1

DEPARTMENT OF MANAGEMENT SCIENCES * * * ILLINOIS INSTITUTE OF TECHNOLOGY

 * OPTIMAL SOLUTION *

STATION NAME	STAGE	COMPO -NT	TYPE OF STN	N	C	DEFECT	A00	A00L	PI	PT	STAGE COST	MINIMUM EXPECTED COST F*	SUR OPT SOLN	ALT IND	REMARKS
	5	4	I	71	6		.049	.050	.055		831.6	78960.0	0	0	
TWO	4	5	A			.055			.000	.055	6818.2	78128.4	0	0	*
	4	4	A						.000				0	0	*
	4	3	A						.000				0	0	*
	4	2	A						.000				0	0	*
	3	2	I	1000	0		.000	.000	.100		1500.0	29107.4	1		
ONE	3	4	I	1000	0		.000	.000	.085		1605.0	18362.9	0		
	2	2	A			.060			.000	.100	4166.7	27607.4	0	0	*
	2	1	A						.045				0	0	*
	2	4	M			.085			.000	.085	5558.8	16757.9	0		
	1	1	I	41	3		.045	.000	.065		318.6	13241.7	0		
	1	2	I	1000	0		.000	.000	.065		737.5	10199.0	0		
	1	3	I	1000	0		.000	.000	.080		1170.0	11920.0	0		
	1	4	I	1000	0		.000	.000	.065		737.5	11199.0	0		
	1	5	I	1000	0		.000	.000	.080		1170.0	11920.0	0		

 END OF REPORT

OF IN

NIFQ

APPENDIX B
THE LISTING OF THE MAIN PROGRAM

GELT.L WUL002*1UI.MAIN

EL1007L M72MIC 12/21/76 15:25:39 (4,)

000001 000 C *****
000002 000 C * DESIGN OF MANUFACTURING QUALITY SYSTEM *
000003 000 C *****
000004 000 C *****

000005 000 C DESIGN OF INCOMING QUALITY LEVEL, PROCESS QUALITY LEVEL
000006 004 C AND OPTIMAL INTERRELATED LOT-BY-LOT SINGLE SAMPLING PLANS
000007 004 C FOR A SINGLE PRODUCT MULTI-STAGE MANUFACTURING
000008 004 C SYSTEM.
000009 000 C THIS WORK WAS PARTIALLY SUPPORTED BY THE OFFICE OF NAVAL RESEARCH
000010 000 C UNDER CONTRACT NUMBER N00014-76-C-0841

000011 000 C
000012 000 C PRINCIPAL INVESTIGATORS -
000013 004 C M. ZIA HASSAN AND THOMAS W. KNOWLES
000014 000 C REFERENCES -
000015 000 C BASED PARTIALLY ON PHD DISSERTATIONS BY R. SUBRAMANIAM AND
000016 000 C A. MANASPITI, DEPARTMENT OF MANAGEMENT SCIENCES, ILLINOIS
000017 000 C INSTITUTE OF TECHNOLOGY, CHICAGO, IL 60616.

000018 000 C
000019 000 C PROGRAMMERS -
000020 000 C APHAI MANASPITI AND PHICHA PANTUMSINCHAI

000021 000 C *****
000022 000 C *****
000023 004 C *****
000024 004 C *****
000025 000 C *****
000026 000 C *****

000027 000 C THE MAIN PROGRAM CONTROLS CALLING OF SUBROUTINES AND SETS THE
000028 000 C NECESSARY PARAMETERS TO ACCOMMODATE THE PROBLEM TO BE SOLVED.

000029 000 C *****
000030 000 C *****
000031 000 C *****
000032 000 C *****

000033 000 C THESE ARRAYS AND VECTORS ARE CONTROLLED BY THE USER.

000034 000 C *****
000035 000 C DIMENSION A00(J5),A00L(J5),ATT(J5,J6),A00Y(J5),
000036 000 C C(J5,J6),CC(J3),CIN(J4,2),CHAN(J1),CT(J10),CY(J5),CYN(J5),
000037 000 C COR(J2,2),

000038 000 C F0(J5),FAI(J9),FUN(J5),F11(J9),F12(J6),FM(J2),
000039 000 C I ISUB(J9),IASM(MAXCOM),INDEX(MAXCOM,MAXSTG,2),INDX(J9),
000040 000 C I IALT(J9),

000041 000 C K RVECT(J6),KXI(MAXCOM),KCPRAW(MAXCOM,2),KSUB(J5),
000042 000 C L LSUB(J5),
000043 000 C M MODEL(MAXCOM,MAXSTG),MODL(MAXCOM,MAXSTG),

000044 000 C N NPKVS(MAXCOM),NSTRUC(MAXCOM,MAXSTG),NSY(J5),NYN(J5),NSN(J5,J6),
000045 000 C N NPI(J7),NTPVS(MAXCOM),NET(MAXCOM),NDX1(J9),NDX2(J9),
000046 000 C P P0(J8),PFO(J8),PAI(J9),PIA1(J9),PIA2(J9),PIY(J5),PPY(J5),
000047 000 C P PRAW(J7),PIYNT(J5),PP(J3),PI(J6),PII(J9),PI2(J6),PM(J2),

000048 000 C U UT(J10),
000049 000 C T TPC(J5),TISC(J5)

000050 000 C *****
000051 000 C *****
000052 000 C *****

000053 000 C INTEGER C,CT,CYN
000054 000 C COMMON /UC1/ ILEKROH,NRD,NMR,NDS
000055 000 C COMMON /UC3/ NPRT

```

000056 COMMON /QC7/ J1,J2,J3,J4,MAXCOM,MAXSTG,I1,I2,I3,I4,J5,J6,J7,I5,I6,MIN00056
000057 117,J8,J9,J10,I8,I9,I10 MIN00057
000058 C C MIN00058
000059 C C MIN00059
000060 C C MIN00060
000061 C C MIN00061
000062 C C MIN00062
000063 C C MIN00063
000064 C C MIN00064
000065 C C MIN00065
000066 C C MIN00066
000067 C C MIN00067
000068 C C MIN00068
000069 C C MIN00069
000070 C C MIN00070
000071 C C MIN00071
000072 C C MIN00072
000073 C C MIN00073
000074 C C MIN00074
000075 C C MIN00075
000076 C C MIN00076
000077 C C MIN00077
000078 C C MIN00078
000079 C C MIN00079
000080 C C MIN00080
000081 C C MIN00081
000082 C C MIN00082
000083 C C MIN00083
000084 C C MIN00084
000085 C C MIN00085
000086 C C MIN00086
000087 C C MIN00087
000088 C C MIN00088
000089 C C MIN00089
000090 C C MIN00090
000091 C C MIN00091
000092 C C MIN00092
000093 C C MIN00093
000094 C C MIN00094
000095 C C MIN00095
000096 C C MIN00096
000097 C C MIN00097
000098 C C MIN00098
000099 C C MIN00099
000100 C C MIN00100
000101 C C MIN00101
000102 C C MIN00102
000103 C C MIN00103
000104 C C MIN00104
000105 C C MIN00105
000106 C C MIN00106
000107 C C MIN00107
END ELT.

```

```

*****
SET THE ARRAYS AND VECTORS CORRESPONDING TO THE PARAMETERS HERE
*****
DIMENSION A00(25), A00L(25), A11(25,50), A00Y(25), C(25,50), CC(20MIN00063
10), CIN(25,2), CRA(1180), CT(50), CY(25), CYN(35,2), COR(35,2), FOI2MIN00064
25), FAI(105), FON(25), F11(105), F12(50), FM(35), ISUB(105), IASM(MIN00065
315), INDEX(15,14,2), INDX(105), IALT(105), KVEC(50), KXI(15), KCPRMIN00066
M(15,2), KSUB(25), LSUB(25), MODEL(15,14), MODL(15,14), NPROV(15)MIN00067
5, NSTRUC(15,14), NSY(25), NYN(25), NSN(25,50), NIPI(205), NTPVS(15MIN00068
6), NFI(15), NDX1(105), NDX2(105), PO(150), PFO(150), PAI(105), PIAMIN00069
71(105), PIA2(105), PIY(25), PPY(25), PRAW(180), PIYN(25), PP(200), MIN00070
A PI(50), P11(105), P12(50), PM(35), QT(50), TPC(25), TISC(25)
MIN00072
MIN00073
MIN00074
MIN00075
MIN00076
MIN00077
MIN00078
MIN00079
MIN00080
MIN00081
MIN00082
MIN00083
MIN00084
MIN00085
MIN00086
MIN00087
MIN00088
MIN00089
MIN00090
MIN00091
MIN00092
MIN00093
MIN00094
MIN00095
MIN00096
MIN00097
MIN00098
MIN00099
MIN00100
MIN00101
MIN00102
MIN00103
MIN00104
MIN00105
MIN00106
MIN00107

```

NIFO

GFIN

APPENDIX C
THE LISTING OF THE SUBROUTINE COSTFN

MELT,L WDE002*TUI,COSIFN
ELT007C R72R1C 07/31/78 14:41:26 (4,)

SUBROUTINE COSTFN(NN,ICOM,JSTG,COR)

```
000001 004 C CFN00001
000002 004 C CFN00002
000003 004 C CFN00003
000004 004 C CFN00004
000005 004 C CFN00005
000006 004 C CFN00006
000007 004 C CFN00007
000008 004 C CFN00008
000009 004 C CFN00009
000010 004 C CFN00010
000011 004 C CFN00011
000012 004 C CFN00012
000013 004 C CFN00013
000014 004 C CFN00014
000015 004 C CFN00015
000016 004 C CFN00016
000017 004 C CFN00017
000018 004 C CFN00018
000019 004 C CFN00019
000020 004 C CFN00020
000021 004 C CFN00021
000022 004 C CFN00022
000023 004 C CFN00023
024 004 C CFN00024
025 004 C CFN00025
026 004 C CFN00026
027 004 C CFN00027
---028 004 C CFN00028
000029 004 C CFN00029
000030 004 C CFN00030
000031 004 C CFN00031
000032 004 C CFN00032
000033 004 C CFN00033
000034 004 C CFN00034
000035 004 C CFN00035
000036 004 C CFN00036
000037 004 C CFN00037
000038 004 C CFN00038
000039 004 C CFN00039
000040 004 C CFN00040
000041 004 C CFN00041
000042 004 C CFN00042
000043 004 C CFN00043
000044 004 C CFN00044
000045 004 C CFN00045
000046 004 C CFN00046
000047 004 C CFN00047
000048 004 C CFN00048
000049 004 C CFN00049
000050 004 C CFN00050
000051 004 C CFN00051
000052 004 C CFN00052
000053 004 C CFN00053
000054 004 C CFN00054
000055 004 C CFN00055
```

THIS SUBROUTINE GENERATES COORDINATES OF COST CURVES AS SPECIFIED BY USERS. THERE ARE 9 FUNCTIONAL TYPES POSSIBLE. THE STANDARD ONE PROVIDED HERE IS WHEN NCD=1. OTHER FORMS MAY BE SPECIFIED BY USERS WHEN NCD=2,3,....9. LABELS ARE GIVEN.

THE FOLLOWING COMMON BLOCKS MUST REMAIN AT ALL TIME

COMMON/GC1/IEERROR,NRD,NWR
COMMON/GC4/NVECT207,NSTG(57),NAME(57),NAM(14)
COMMON/GC5/AOQLF,GRIDS,FMAX,LOTSZ,AF
COMMON/GC6/GRSZ,UN,UP,A(7),NUMCOR,NUMF,NUMT,NCD,NAP
COMMON/GC7/J1,J2,J3,J4,MAXCOM,MAXSTG,11,12,13,14

DIMENSION COR(J2,2)

WARNING & DO NOT CHANGE VALUES OF VARIABLES ALREADY DEFINED EXCEPT FN.

DEFINITIONS OF VARIABLES &-
GRSZ = GRID SIZE OF QUALITY LEVEL P
UN = LOWER LIMIT OF QUALITY LEVEL P
UP = UPPER LIMIT OF QUALITY LEVEL P
A(1),...A(7) = CONSTANTS READ IN FOR A COST FUNCTION
X = QUALITY LEVEL P
FN = UNIT COST

IF (GRSZ.LE.0.OR.UN.LT.0.OR.UP.LE.UN.OR.UP.LE.0.) GO TO 40
IF (NCD.LT.0.OR.NCD.GT.9.OR.UN.GT.1..OR.UP.GT.1.) GO TO 40
BOUND=UP
IF (AF.LT.UP) BOUND=AF
I=0
X=UN+GRSZ
10 X=X+GRSZ
IF (X.GT.BOUND) GO TO 120
20 I=I+1
GO TO (1,2,3,4,5,6,7,8,9), NCD
1 FN=A(1)/X+A(2)
GO TO 30
*** THE FOLLOWING LABELLED STATEMENTS MAY BE ALTERED ***
2 FN=1/X
GO TO 30
3 FN=1/X
GO TO 30
4 FN=1/X
GO TO 30
5 FN=1/X
GO TO 30
6 FN=1/X
GO TO 30
7 FN=1/X
GO TO 30
8 FN=1/X

```

000056 004 60 TO 30
000057 004 9 FN=1/X
000058 004 C
000059 004 C *** END ALTERABLE ***
000060 004 30 COR(I,1)=X
000061 004 COR(I,2)=FN
000062 004 60 TO 10
000063 004 40 60 TO (50,70,90), NN
000064 004 50 WRITE(NWR,60) ICOM,NCD
000065 004 60 FORMAT('0**** INPUT ERROR ***** RAW MATERIAL COSTS, COMPONENT',
000066 004 'I 15,5X,'COST FUNCTION TYPE',I3)
000067 004 60 TO 110
000068 004 70 WRITE(NWR,80) ICOM,JSTG,NCD
000069 004 80 FORMAT('0**** INPUT ERROR ***** PROCESSING COSTS , COMPONENT',
000070 004 'I 15,5X,'STAGE',I5,5X,'COST FUNCTION TYPE',I3)
000071 004 60 TO 110
000072 004 90 WRITE(NWR,100) ICOM,JSTG,NCD
000073 004 100 FORMAT('0**** INPUT ERROR ***** ASSEMBLY COSTS , COMPONENT',I5,
000074 004 'I 5X,'STAGE',I5,5X,'COST FUNCTION TYPE',I3)
000075 004 110 IERROR=1
000076 004 RETURN
000077 004 120 NUMCOK=1
000078 004 IF(NUMCOR.GT.I2) I2=NUMCOR
000079 004 IF(I2.LE.J2) RETURN
000080 004 IERROR=1
000081 004 WRITE(NWR,130)
000082 004 130 FORMAT('0**** ERROR ***** J2 IS EXCEEDED')
000083 004 RETURN
000084 004 END

```

END ELT.