

AD-A074 084

FOREIGN TECHNOLOGY DIV WRIGHT-PATTERSON AFB OH
ANALYSIS OF CERTAIN STRUCTURES OF DATA TRANSMISSION DEVICES, (U)
DEC 78 R I SHNEYDER

F/O 17/2

UNCLASSIFIED

FTD-ID(RS)T-1910-78

NL

| OF |
AD
A074084
FEB 79

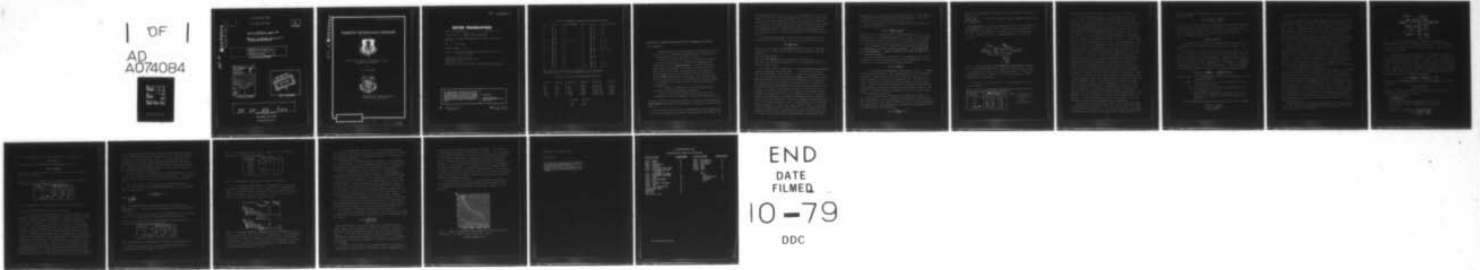

END
DATE
FILMED
10-79
DDC

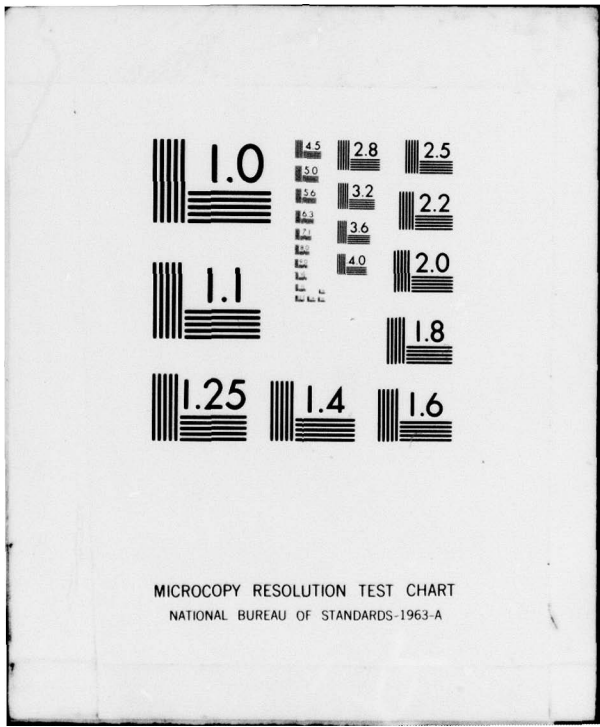

MICROCOPY RESOLUTION TEST CHART
NATIONAL BUREAU OF STANDARDS-1963-A

DATA PROCESSING SHEET

PHOTOGRAPH THIS SHEET

1
INVENTORY

LEVEL

AD A074084

DDC ACCESSION NUMBER

FTD-ID(RS)T-1910-78

Analysis of Certain Structures...
DOCUMENT IDENTIFICATION

This document has been approved
for public release and sale; its
distribution is unlimited.

DISTRIBUTION STATEMENT

Accession For	
NTIS GRA&I	<input checked="" type="checkbox"/>
DDC TAB	<input type="checkbox"/>
Unannounced	<input type="checkbox"/>
Justification	
By _____	
Distribution/ _____	
Availability Codes	
Dist	Avail and/or special
A	

DISTRIBUTION STAMP

DDIC
RECEIVED
SEP 24 1979
C

DATE ACCESSIONED

79 04 26 320

DATE RECEIVED IN DDC

PHOTOGRAPH THIS SHEET

AND RETURN TO DDA-2

AD A DA 074084

FTD-ID(RS)T-1910-78

FOREIGN TECHNOLOGY DIVISION



ANALYSIS OF CERTAIN STRUCTURES OF DATA
TRANSMISSION DEVICES

by

R.I. Shneyder

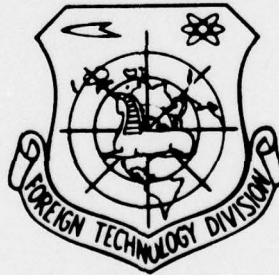

Approved for public release;
distribution unlimited.

79 04 26 320

EDITED TRANSLATION

FTD-ID(RS)T-1910-78

6 December 1978

MICROFICHE NR:

FD-78-C-001704

ANALYSIS OF CERTAIN STRUCTURES OF DATA TRANSMISSION
DEVICES

By: R.I. Shneyder

English pages: 14

Source: Voprosy Promyshlennoy Kibernetiki, No. 29,
1971, pp. 62-66

Country of origin: USSR

Translated by: Robert D. Hill

Requester: RCA

Approved for public release; distribution unlimited.

THIS TRANSLATION IS A RENDITION OF THE ORIGINAL FOREIGN TEXT WITHOUT ANY ANALYTICAL OR EDITORIAL COMMENT. STATEMENTS OR THEORIES ADVOCATED OR IMPLIED ARE THOSE OF THE SOURCE AND DO NOT NECESSARILY REFLECT THE POSITION OR OPINION OF THE FOREIGN TECHNOLOGY DIVISION.

PREPARED BY:

TRANSLATION DIVISION
FOREIGN TECHNOLOGY DIVISION
WP.AFB, OHIO.

U. S. BOARD ON GEOGRAPHIC NAMES TRANSLITERATION SYSTEM

Block	Italic	Transliteration	Block	Italic	Transliteration
А а	А а	A, a	Р р	Р р	R, r
Б б	Б б	B, b	С с	С с	S, s
В в	В в	V, v	Т т	Т т	T, t
Г г	Г г	G, g	У у	У у	U, u
Д д	Д д	D, d	Ф ф	Ф ф	F, f
Е е	Е е	Ye, ye; E, e*	Х х	Х х	Kh, kh
Ж ж	Ж ж	Zh, zh	Ц ц	Ц ц	Ts, ts
З э	З э	Z, z	Ч ч	Ч ч	Ch, ch
И и	И и	I, i	Ш ш	Ш ш	Sh, sh
Й й	Й й	Y, y	Щ щ	Щ щ	Shch, shch
К к	К к	K, k	Ъ ъ	Ъ ъ	"
Л л	Л л	L, l	Ы ы	Ы ы	Y, y
М м	М м	M, m	Ь ь	Ь ь	'
Н н	Н н	N, n	Э э	Э э	E, e
О о	О о	O, o	Ю ю	Ю ю	Yu, yu
П п	П п	P, p	Я я	Я я	Ya, ya

*ye initially, after vowels, and after ь, ы; e elsewhere.
When written as ë in Russian, transliterate as yë or ë.

RUSSIAN AND ENGLISH TRIGONOMETRIC FUNCTIONS

Russian	English	Russian	English	Russian	English
sin	sin	sh	sinh	arc sh	sinh ⁻¹
cos	cos	ch	cosh	arc ch	cosh ⁻¹
tg	tan	th	tanh	arc th	tanh ⁻¹
ctg	cot	cth	coth	arc cth	coth ⁻¹
sec	sec	sch	sech	arc sch	sech ⁻¹
cosec	csc	csch	csch	arc csch	csch ⁻¹

Russian English

rot curl
lg log

ANALYSIS OF CERTAIN STRUCTURES OF DATA TRANSMISSION DEVICES

R.I. Shneyder

Examined is one of the methods of increasing the technical speed of information transmission - the application of codes with partial correction of errors.

The use of codes with partial correction of errors (correction and detection) considerably decreases the probability of the **repeat-request**. However, increased here is the redundancy of the code, and the device is made complicated, since the decoder for the code with partial correction is more complex than the decoder for the code ^{with} the detection of the errors. Thus the decrease in the operational flows by increasing the technical speed of transmission is connected with the growth in capital expenditures.

In a number of cases the use of codes with partial correction of errors produces a savings.

Some of the possible structures of this kind (for transmission of the "tape-tape" type) are examined below.

Structure of the Device with Reverse of Carrier, Zero-Address **Repeat-request** and Code which Partially Corrects the Errors (Structure 1)

The selection of the code is determined by the assigned certainty and striving for the maximal increase in the nominal rate

of transmission of the device V_0 (i.e., transmission rate in the absence of errors). Here the nominal rate is limited by the rate of operation of the input-output devices. Thus the minimal certified speed of the tape punch PL-150 is 140 characters per second. When using the standard seven-element code, with the supplement of each character up to oddness, the maximum transmission rate at a modulation rate of 1200 baud consists of 150 characters per second.

In order that the punch would succeed for the flow of the information being received, it follows to provide the relation

$$\frac{m}{n} < \frac{140}{150} = 0,935,$$

where m is the number of information bit positions of the code combination; n is the total number of bit positions of the combination.

Let us denote $\frac{m}{n} = R$

and call this quantity the coefficient of efficiency. It is desirable to approximate maximally R to the maximum number 0.935, which we denote R_{\max} .

For codes with a correction of errors possessing considerably greater redundancy than codes with the detection of errors (at the same certainty), the values of R , which are approximated to R_{\max} , can be obtained only with code combinations of great length. But the decoders for such codes are constructed on the basis of registers with the number of cells equal to n . Therefore, for the purpose of simplifying the device, it is expedient to decrease the length of the codes, and here the value of R is decreased. From the code with $n = 341$ and $m = 315$, which has the minimal code distance $d = 6$, it is possible to turn to a shorter code, having decreased the number of information bit positions down to 120 (15 characters). For the obtaining of the same value of d , it follows to take $n = 146$. In comparison with the initial code, for which $R = 0.925$, with this code $R = 0.82$. It is capable of correcting errors of the multiple of 2 and detecting the minimum 3-fold errors. Besides the 26 excess bit positions (cyclic code), each character is completed up to odd parity, and,

consequently, by the checking of each character for "odd number" it is possible additionally increase the certainty. The total quantity of excess bit positions is equal to 41.

The probability of the error procedure of the character is computed by formula [1]

$$P_{\text{ош. зн}} = \frac{C_{n+1}^t}{2^{41.15}} p_0 \left(\frac{n}{S+1} \right)^{1-\alpha},$$

where t is the multiplicity of the correctable errors; S - the multiplicity of the guaranteed detectable errors; α - the coefficient which considers the degree of "bunching" of the errors; p_0 - probability of distortion of the elementary bit position.

Let us determine the reliability for the worse conditions of transmission, considering that $p_{0 \text{ макс}} = 10^{-2}$ and $(1-\alpha)_{\text{макс}} = 0.8$. Then $P_{\text{ош. зн}} = 0.64 \cdot 10^{-10}$, which provides a very high reliability on the poorest channels.

Let us estimate the probability of appearance in the code combination of such an error which is not corrected but is detected (i.e., the probability of repeat-request)

$$P_{\text{ошн.}} = p_0 \left(\frac{n}{t+1} \right)^{1-\alpha}.$$

Let us examine the structure of the device (Fig. 1). Besides the input-output device 1 and coupling module 2, the transmitter contains a coding device 3 and two registers 4 and 5; the receiver contains a decoder 6 and registers 7-9. Registers 7 and 8 have each 120 bit positions and the register 9, 26 bit positions. Given on the block diagram are a channel-forming device, synchronization modules and modules of the reverse channel. The decoder is similar to the one described in [2] for cyclic codes with the majority decoding.

Let us assume that the module of information consists of two combinations. Let us estimate the efficiency of the system. The coefficient of the repeat-request ξ_1 is the number which shows how many times on the average one combination is transmitted and is determined by the expression

$$\xi_1 = \frac{1 + \nu_p}{(1 - P_{\text{ошн.}})^2} - \nu_p,$$

where β is the number of combinations in the module (in the given case $\beta = 2$),

$v_p = \lambda + (\lambda + 1)\alpha_p$ (λ - number of modules being repeated together with the distorted).

$\alpha_p = \frac{V_M}{zV_p} R$, here V_M is the modulation rate; z - the number of bit positions in a character; V_p - the rate of the reverse. In this case $V_M = 1200$ baud, $z = 8$ bits, $V_p = 220$ characters/s, $R = 0.82$. Hence $\alpha_p = 0.62$. Considering that $\lambda = 1$, we get: $v_p = 2.24$.

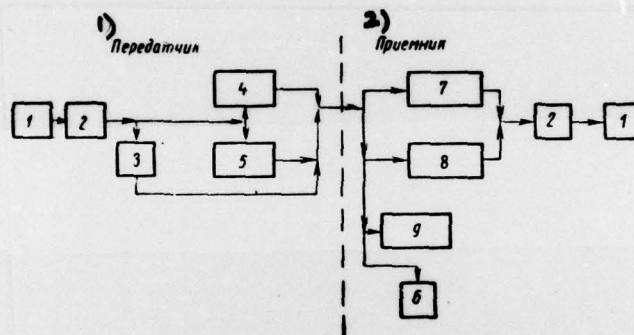

Fig. 1. Structure with a zero-address repeat-request, reverse of the carrier and code which partially corrects the errors: 1 - input-output device; 2 - coupling module; 3 - coder; 4-5 - shift registers; 6 - decoder; 7-9 - shift registers. KEY: 1) Transmitter; 2) Receiver.

Results of the calculation of the transmission rate are given in Table 1.

Table 1 Rate of Information Transmission at Three States of the Channel for Devices with Structure 1

1) Параметры	2) Обозначение состояния		
	a	b	v
P_0	10^{-3}	$5 \cdot 10^{-3}$	10^{-2}
$1-u$	0.8	0.6	0.8
$P_{обм.}$	0.022	0.051	0.223
ξ_1	1.16	1.36	3.13
$V, \text{ знак/сек}$ 3)	106	90.5	39.4

KEY: 1) Parameters;
2) Designation of state;
3) character/s.

Structure with Automatic Request of Correction (Structure 2)

In the preceding structure, for the provision of values R close to R_{\max} , it was necessary to select codes with a large number of bit positions, since with the presence and absence of errors the code with partial correction of the errors was used. One of the possible means of shortening the length of the code combinations (with the appropriate decrease in the number of bit positions of the registers) while retaining an efficiency close to R_{\max} is the method of automatic request of the correcting bit positions with the detection of the error. In this case the code with the detection of the error (and, consequently, with little redundancy) is constantly used. With the detection of an error in the code combination, according to the request from the receiver the transmitter sends the correcting bits for the correction of errors in the distorted combination. This makes it possible to increase the rate of information transmission owing to the practically complete exclusion of the multiple repetitions of the same combination. Furthermore, usually the length of the correcting part in codes with the correction of errors (at not too large of values of d) less than the information, in connection with which its storage in the transmitter is simpler to accomplish than the storage of information. Therefore, it is possible to exclude the reverse of the carrier with a request of the correction. This makes it possible to make the device more simple than the device with access to the memory and to provide a higher rate of transmission than for devices with a reverse of the carrier. Furthermore, a device of such type on channels of very poor quality provides considerably greater rates of transmission than the device with access to the memory. Let us note that in the case of the unsuccessful correction, in the transmitter a reverse of the carrier with repetition of the distorted information is carried out.

Let us select the information part of the code combination $n = 88$ bits (11 characters). When $R = 0.92$, $n = 96$. The number of correcting bit positions $k = 8$. Thus we take for the normal transmission the cyclic code (96.88) with a code distance $d = 4$.

Let us determine the probability of the error in a character.
 With this code:

$$P_{\text{ош. зн.}} = \frac{1}{2^{k_1} \cdot 11} \cdot p \cdot \left(\frac{n}{d}\right)^{1-\alpha},$$

where k_1 is the total number of redundant bit positions determined as the sum of the correcting bit positions for the cyclic code ($k = 8$) and bit positions which complete each character up to the "odd." Since there are 11 characters, then $k_1 = 11 + 8 = 19$.
 When $p_0 = 10^{-2}$ and $1 - \alpha = 0.8$

$$P_{\text{ош. зн.}} = 0,115 \cdot 10^{-6}.$$

A simple module is used in the mode of error detection, i.e., the length of the combination coincides with the length of the module.

For the mode of error correction, we use the code (73, 45) with $d = 10$, which corrects the four-fold and detecting five-fold errors. This code has separate checks. Having shortened it by one bit position (72, 44), we obtain in the case of the correction the composite module (two combinations). The number of redundant bit positions $k_2 = 28$ (for each combination). Let us determine the reliability which is provided in the error correction mode.

$$P'_{\text{ош. зн.}} = \frac{C_{n_u+1}^{n_u}}{2^{l_1} \cdot 2^{k_2} \cdot l_1} \cdot p_0 \left(\frac{n_u}{S+1}\right)^{1-\alpha} + P_{\text{ош. зн.}},$$

where $P'_{\text{ош. зн.}}$ is the probability of error in the character in the correction mode;

$P_{\text{ош. зн.}}$ - the probability of error in the character in the error detection mode;

n_u - the number of bit positions in combination with the correction of errors;

l_1 - the number of characters contained in the information part of combination with the error correction.

Let determine the reliability with poor state of the channel

$$p_0 = 10^{-2}; \quad 1 - \alpha = 0,8.$$

$$P'_{\text{ош. зн.}} \approx 1,0 \cdot 10^{-6}.$$

Thus the probability of error on a character does not exceed 10^{-6} .

A block diagram of the device is given on Fig. 2. With the transmission without errors, the information is successively recorded into the registers 3 and 4 and is issued to the communication channel. Being generated in the coder 7 are the correcting bit positions according to the law of the code with detection and the code with error correction. The former are sent to the communication channel, supplementing each information module. The second ones are recorded in the registers 5 and 6 (connected in series), in which stored simultaneously are the correcting bit positions for three modules ($3 \times 56 = 168$ bit positions).

The information on reception enters into alternately registers 9 and 10, whereupon at the moment of recording from register 10 into register 9 the information is brought out to the carrier. The correctness of the reception is checked by the decoder 8. When an error is detected, for example, in the third module, it is stored in the register (for example, 9), after which the next combination (fourth) is recorded into the register 10. The fifth combination is inhibited.

In the transmitter, in the process of the output of the fifth module, the request of correcting bits for the third module is decoded; they are sent into the channel after the fifth module. The correcting bit positions are recorded into register 11, after which the processing is begun^{and} in the case of the successful decoding, the output of the third module onto the carrier. During the transmission of the correcting bits there occurs the reverse of the carrier onto one module. By the moment of the completion of the output of the third module, the transmitter again sends the fifth module. The receiver puts out the fourth module (if it receives correctly) with the simultaneous recording of the fifth module, and so on.

With unsuccessful correction according to the reverse channel, there is sent the secondary signal "incorrectly," which denotes the reverse of the carrier.

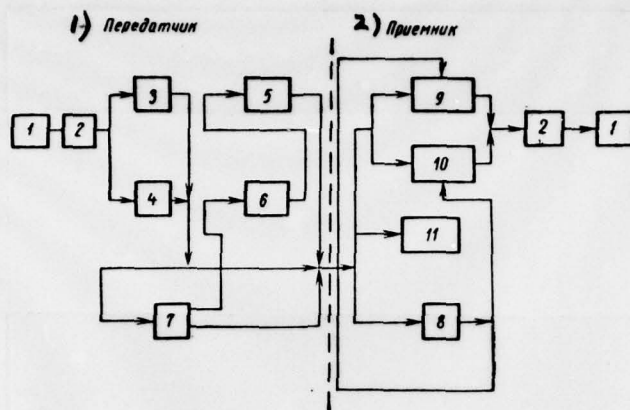

Fig. 2. Structure with automatic request of correction: 1 - input-output device; 2 - coupling module; 3-6 - shift registers; 7 - coder; 8 - decoder; 9-11 - shift registers. KEY: 1) Transmitter; 2) Receiver.

The main units of the receiver are the decoder, registers 9 and 10 (88 bits each) and register 11 (56 bits). The main units of the transmitter are the coder 7, registers 5 and 6 (similar to registers 9 and 10 of the receiver) and registers 3 and 4 (28 bits each). In the case of the combination of the receiver and transmitter, registers 3 and 4 coincide with register 11 and registers 5 and 6 with registers 9 and 10. To determine the coefficient of repeat-request ξ_1 , we get the expression

$$\xi_1 = 1 + \frac{P_{\text{обн}}(r + v_1)}{1 - P_{\text{обн}}} + \frac{P_{\text{обн}}(1 + v_2)}{1 - P_{\text{обн}}}; \quad r = \frac{t_k}{t_{6л}},$$

where t_k is the transmission time of the correcting bits for the correction.

$$v_1 = 1; \quad v_2 = 3 + 4z_p,$$

where v_1 is the loss in time of transmission with reverse expressed in the number of modules.

In the given case:

$$a_p = 0,626; \quad v_2 = 5,5;$$

$$t_k = 45,6 \text{ ms (time of transmission of 56 bits);}$$

$$t_{6л} = 80 \text{ ms (time of transmission of 96 bits);}$$

$$r = 0,58.$$

Thus the coefficient of repeat-request

$$\xi_1 = 1 + \frac{P_{\text{обн}} \cdot 1,58}{1 - P_{\text{обн}}} + \frac{P_{\text{обн}} \cdot 6,5}{1 - P_{\text{обн}}}.$$

The probability of the distortion of the combination

$$P_{\text{ош.}} = p_0 n^{1-\alpha}$$

The probability of detection of the uncorrected error

$$P_{\text{обн.}} = p_0 \cdot \left(\frac{n_u}{l+1}\right)^{1-\alpha}$$

Results of the calculation for the three states of the channel are given in Table 2.

Table 2 Rate of Information Transmission with Three States of the Channel for the Device with Structure 2

1) Параметр	2) Обозначение состояния		
	a	b	в
$P_{\text{ош}}$	0.0385	0.0786	0.32
$P_{\text{обн.}}$	0.0146	0.0375	0.146
ξ_1	1.105	1.225	2.64
$V, \text{ знак/сек}$ 3)	125	112	52

KEY: 1) Parameters; 2) Designation of state; 3) character/s.

Structure with Reverse of Carrier (Structure 3)

Let us examine the characteristics of this structure in the example of the device APD-3 developed at TsNIIKA [State All-Union Central Scientific Research Institute of Complex Automation] (see insert to page 56). Used in the device is a cyclic code (40, 32) $d = 4$ with error detection. The module of information consists of six combinations (240 bits). The answer as to the absence or presence of the distorted combinations in the module is sent along the whole module after its reception (decoding is conducted according to the code combinations). Deciphering of the answer by the transmitter is accomplished in the process of reception of the next module. When an error is detected in one of the modules, the decoding is ceased after the reception of the distorted combination. Upon completion of the reception of the distorted module, the request for repeating is sent. The subsequent module is also not decoded by the receiver. Upon completion

of the transmission of the module following the distorted, there is carried out the reverse of the carrier on two modules (being conducted at this time in the channel is synchronization and cophasing), after which again transmitted along the channel are the earlier distorted module and the module following behind it. Decoding of the distorted module is begun after reception of the earlier distorted combination.

The main units of the device are two recorders (50 bits each), a coder and a decoder for codes with error detection. The probability of the error reception of the character does not exceed 10^{-6} .

The coefficient of efficiency for the examined device is $R = 0.8$. The coefficient of the repeat-request ξ_1 is determined from the expression

$$\xi_1 = \frac{1 + \nu_p}{(1 - P_{\text{ош. 1}})^{\beta^{\alpha-1}}} - \nu_p,$$

where $\nu_p = 2.09$,
 $\alpha_p = 0.545$
 $\beta = 6$

$P_{\text{ош. 1}}$ is the probability of distortion of the combination;

$P_{\text{ош. 1}} = p_0 n^{1-\alpha, n}$ - the number of bit positions in the combination ($n = 40$).

Results of the calculation of the transmission rate for three states of the communication channel are given in Table 3.

Table 3 Transmission Rate of Information with Three States of the Channel for Devices with Structure 3

1) Параметры	2) Обозначение состояний		
	а	б	в
$P_{\text{ош. 1}}$	0,019	0,0455	0,79
ξ_1	1,27	1,48	4,77
V, знак/сек 3)	95	81	25,2

KEY: 1) Parameters; 2) Designation of states; 3) character/s.

Results of calculations of the transmission rate for the examined structures are given in Table 4.

Table 4 Comparative Results of the Calculation of the Transmission Rate for Three Structures

1) Параметры распределения	2) Тип структуры		
	1	2	3
$P_0 = 10^{-3}$ $1 - \alpha = 0.8$	106	125	95
$P_0 = 5 \cdot 10^{-3}$ $1 - \alpha = 0.6$	90.5	112	81
$P_0 = 10^{-2}$ $1 - \alpha = 0.8$	39.4	52	25.2

KEY: 1) Distribution parameters; 2) Type of structure.

Let us estimate approximately in submodules of the system "Spectrum" the additional flow of elements in the examined devices in comparison with the simplest device, which uses the code with error detection and reverse of the carrier (structure 3). Results of the calculation are given below:

1) Функциональный блок	2) Число ячеек	3) Приведенное число субблоков
Структура 1		
5 Регистры	320	80
6 Кодер-декодер:		
7 сумматоры	16	
8 потенциальная память	8	8
9 мажоритарный орган	4	1
10 обегаяющий распределитель	8	2
11 Всего		91
Структура 2		
13 Регистры	232	58
14 Кодер-декодер:		
15 сумматоры	10	
16 потенциальная память	10	7
17 мажоритарный орган	5	2
18 обегаяющий распределитель	8	2
19 Всего		69

KEY: 1) Functional module; 2) Number of cells; 3) Normalized number of submodules; 4) Structure 1; 5) Registers; 6) Coder-decoder; 7) adders; 8) potential memory; 9) majority organ; 10) scanning distributor; 11) Total; 12) Structure 2; 13) Registers; 14) Coder-decoder; 15) adders; 16) potential memory; 17) majority organ; 18) scanning distributor; 19) Total.

It is accepted that the cost of all the submodules, with the exception of the submodules of the magnetic memory, is identical, and each submodule of the memory (60 bits) is equivalent to four standard submodules.

In analyzing the obtained data, we arrive at the conclusion that the structure 2, which possesses the greatest efficiency, at the same time, requires the least additional flow of elements, and further examination of the structure 1 is inexpedient.

Let us determine now the daily duration of transmission at which the use of the device with structure 2 is paid for instead of the device with structure 3. In comparison let us take the standard period of the cover of the expenditure of 3 years (~800 working days). We will consider that two transmitters operate for one receiver. The cost of the semi-complex of the device with structure 3 (K_3) is 15,000 roubles, and the average cost of the submodule is 20 roubles. The cost of the semi-complex of the device with structure 2 reaches $K_2 = 16.38$ thousand roubles.

Calculations are conducted for the three states of the channel of communication as a function of the range of transmission. The appropriate speeds V_2 (for structure 2) and V_3 (for structure 3) are taken from Table 4. Data on the minute-by-minute lease fee for channels of different length are taken from [3].

The limit of efficiency with respect to the time of the daily transmission for devices with structure 2 and 3 is determined from the formula

$$t_{\text{cyr.}} = \frac{1,5(K_2 - K_3)}{800\left(\frac{V_2}{V_3} - 1\right)\mathcal{E}_{0.\text{r}\phi}}$$

$\mathcal{E}_{0.\text{r}\phi}$ - the minute cost of the lease of a telephone channel. When $t > t_{\text{cyr.}}$ it is expedient to use the device with structure 2. Results of the calculations are given in the form of graphs on Fig. 3. It is clear from them that with an increase in the transmission range and worsening of the state of the communication channel, the zone of expediency of the use of structure 3 is decreased.

It must be noted that on the long-distance wire telephone communication channels there is observed a sharp irregularity in

frequency characteristics (amplitude and phase). This leads to a considerable increase in the number of errors. For the compensation of phase distortions, the use of the automatic correction of the phase is necessary. However, the accurate compensation of the irregularity of the group delay time is sufficiently complex. At the same time the coarse correction of the phase can be realized more simply. The correction of error caused by the incomplete correction of the phase characteristic of the channel can be successfully carried out with the use of codes with partial correction of the errors, since the indicated errors have mainly an independent nature.

For purposes of unification of the equipment operating on the telephone channels, for any distances and levels of noise, it is expedient to use devices with automatic request of correction.

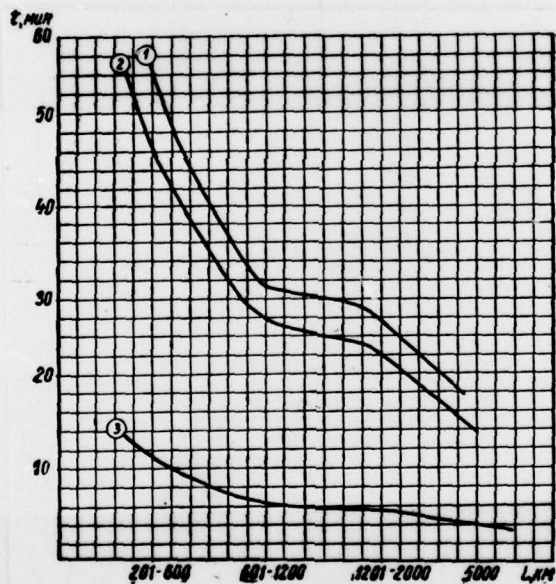

Fig. 3. Limit of efficiency with respect to time of the daily transmission for devices with structure 2 and 3:

1 - $p_0 = 10^{-3}$, $1-\alpha = 0,8$; 2 - $p_0 = 5 \cdot 10^{-4}$,
 $1-\alpha = 0,6$; 3 - $p_0 = 10^{-2}$, $1-\alpha = 0,8$

Submitted 11 December 1969

Bibliography

1. Л. П. Пуртов, А. С. Замрий, А. И. Захаров. Основные закономерности распределения ошибок в дискретных каналах связи. «Электросвязь», 1967, № 2.
2. В. Д. Колесник, Е. Т. Мирончиков. Декодирование циклических кодов, М., Изд-во «Связь», 1968.
3. Сборник тарифов на услуги связи № 125. Госплан СССР, М., 1960.

DISTRIBUTION LIST

DISTRIBUTION DIRECT TO RECIPIENT

<u>ORGANIZATION</u>	<u>MICROFICHE</u>	<u>ORGANIZATION</u>	<u>MICROFICHE</u>
A205 DMATC	1	E053 AF/INAKA	1
A210 DMAAC	2	E017 AF/RDXTR-W	1
B344 DIA/RDS-3C	9	E403 AFSC/INA	1
C043 USAMIA	1	E404 AEDC	1
C509 BALLISTIC RES LABS	1	E408 AFWL	1
C510 AIR MOBILITY R&D LAB/FIO	1	E410 ADTC	1
C513 PICATINNY ARSENAL	1	FTD	
C535 AVIATION SYS COMD	1	CCN	1
C591 FSTC	5	ASD/FTD/NIIS	3
C619 MIA REDSTONE	1	NIA/PHS	1
D008 NISC	1	NIIS	2
H300 USAICE (USAREUR)	1		
P005 DOE	1		
P050 CIA/CRB/ADD/SD	1		
NAVORDSTA (50L)	1		
NASA/KSI	1		
AFIT/LD	1		
ILL/Code L-389	1		

FTD-ID(RS)T-1910-78