

AD-A074 111

NAVAL AIR DEVELOPMENT CENTER WARMINSTER PA ANTIUBMARI--ETC F/G 5/8
STATUS OF ELECTROLUMINESCENT PICTURE DISPLAY PANELS.(U)
NOV 61 F B UPHOFF

UNCLASSIFIED

NADC-AW-6108

NL

| OF |

AD
A074111



END
DATE
FILMED
10-79
DDC

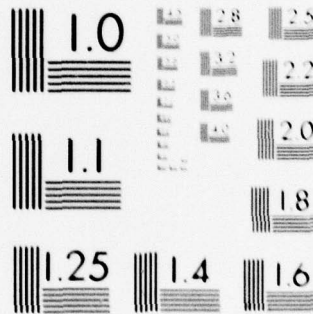

MICROCOPY RESOLUTION TEST CHART
NATIONAL BUREAU OF STANDARDS 1963-A

AD A 0 7 4 1 1 1

UNCLASSIFIED

CLASSIFICATION OF THIS PAGE (When Data Entered)

REPORT DOCUMENTATION PAGE		READ INSTRUCTIONS BEFORE COMPLETING FORM
1. REPORT NUMBER DC-AW-6108	2. GOVT ACCESSION NO.	3. RECIPIENT'S CATALOG NUMBER
4. TITLE (and Subtitle) STATUS OF ELECTROLUMINESCENT PICTURE DISPLAY PANELS		5. TYPE OF REPORT & PERIOD COVERED Phase Report
		6. PERFORMING ORG. REPORT NUMBER
7. AUTHOR(s) Uphoff, F. B.	8. CONTRACT OR GRANT NUMBER(s) Nonr-266(84)	
9. PERFORMING ORGANIZATION NAME AND ADDRESS U. S. Naval Air Development Center Johnsville, PA		10. PROGRAM ELEMENT, PROJECT, TASK AREA & WORK UNIT NUMBERS
11. CONTROLLING OFFICE NAME AND ADDRESS Office of Naval Research, Code 220 800 North Quincy Street Arlington, VA 22217		12. REPORT DATE 17 NOV 1961
		13. NUMBER OF PAGES
14. MONITORING AGENCY NAME & ADDRESS (if different from Controlling Office)		15. SECURITY CLASS. (of this report) UNCLAS
		15a. DECLASSIFICATION/DOWNGRADING SCHEDULE
16. DISTRIBUTION STATEMENT (of this Report) Approved for public release; distribution unlimited.		
17. DISTRIBUTION STATEMENT (of the abstract entered in Block 20, if different from Report)		
18. SUPPLEMENTARY NOTES		
19. KEY WORDS (Continue on reverse side if necessary and identify by block number)		
20. ABSTRACT (Continue on reverse side if necessary and identify by block number)		

U. S. NAVAL AIR DEVELOPMENT CENTER
JOHNSVILLE, PENNSYLVANIA

COLUMBIA UNIVERSITY
HUGSTEN LABORATORIES
CONTRACT Nonr-208(04)

Anti-Submarine Warfare Laboratory

14 REPORT NO. NADC-AW-6108 - PHASE REPORT, STATUS OF ELECTROLUMINESCENT PICTURE DISPLAY PANELS.

BUREAU OF NAVAL WEAPONS
WEPTASK NO. RUSD3B001/2021/FOO4-02-001

11 17 November 1961

12 22p.

D D C
PREPARED
SEP 19 1979
RECEIVED

The state-of-the-art of electroluminescent picture display panels was studied to determine the practicability of these panels for aircraft ASW displays now using cathode-ray tubes. Ferroelectric, photo-conductive, piezoelectric, and transmission-line panels were investigated. None of these panels have been developed to the stage where they can be considered for use in ASW display devices. However, the rapid advances in the developmental work give good cause for optimism.

10 F. B. Uphoff

9 Phase repts.

This document has been approved for public release and sale; its distribution is unlimited.

Reported by: Frank Uphoff
F. B. Uphoff
ASW Systems Division

Approved by: G. M. Yowell
G. M. Yowell, Superintendent
ASW Systems Division

L. D. Goolsby
Director

78 06 23 048

THE DISCUSSIONS OR INSTRUCTIONS CONCERNING COMMERCIAL PRODUCTS HEREIN DO NOT CONSTITUTE AN ENDORSEMENT BY THE GOVERNMENT NOR DO THEY CONVEY OR IMPLY THE LICENSE OR RIGHT TO USE SUCH PRODUCTS.

245 725

50B

DEC 4 1961

S U M M A R Y

INTRODUCTION

Presently available plotting equipment in ASW aircraft is of the electromechanical or cathode-ray tube variety. Initial investigations of solid state techniques have indicated that display and plotting equipment with better operating capabilities may be feasible.

Thus, the U. S. Naval Air Development Center was requested by WEPTASK No. RUSD3B001/2021/FOO4-02-001 to perform a feasibility study of solid state techniques for application to ASW displays. This report covers one phase of the task, namely the status of electroluminescent display panels.

SUMMARY OF INVESTIGATION

Four different types of electroluminescent display panels, namely, ferroelectric, photo-conductive, piezoelectric, and transmission line, were analyzed with respect to cathode-ray tube displays now in use and to the functional requirements of ASW displays. The factors taken into consideration were bulk and complexity of associated circuitry, brightness, resolution, contrast, persistence, response time, switching speed, and life.

CONCLUSIONS

At the present time no electroluminescent panels have been developed with a capability of possible use as an integrated ASW display device and there is no basis to predict that a solid state picture display panel can be developed with a performance to compete with the cathode-ray tube. However, the initial work in electroluminescent displays and the subsequent rapid advances in the field give good cause for optimism. Sustained research and development efforts in some of the significant problem areas are necessary to test the potential of these panels for ASW displays.

The effort thus far has served to define the major problems inhibiting development of a successful solid state display. A number of promising approaches to these problems have been formulated and partially investigated. The work done so far, however, is rudimentary. A phenomena has been discovered and techniques have been demonstrated. Further research, development, and engineering effort are now required to exploit these initial discoveries.

RECOMMENDATIONS

The study indicated that further advancement of the art should be encouraged. It is recommended that the following items be considered toward this advancement:

1. Investigation of propagation of supersonic waves in piezoelectric media (ELP panel).

2. Development of an 8-by 8-inch ELP panel with electronics for producing a raster display.
3. Development of r-f transmission line switching and associated EL panel to demonstrate raster display (8 by 8 inches).
4. Test and evaluation of the ELF panel produced under BUSHIPS Contract Nobsr-72782.
5. Equipping of a laboratory for photometric and optical measurement of EL panel and cathode-ray tube screen performance.
6. Obtaining samples of EL panels for measurement and comparative evaluation.
7. Development of signal distribution circuitry and screen measurement methods for panels that are available commercially.

TABLE OF CONTENTS

	Page
SUMMARY	1
Introduction	1
Summary of Investigation	1
Conclusions	1
Recommendations	1
BACKGROUND	1
CATHODE-RAY TUBE PERFORMANCE	2
DISPLAY REQUIREMENTS	3
ELECTROLUMINESCENT FERROELECTRIC (ELF) PANEL	3
ELECTROLUMINESCENT PHOTO-CONDUCTIVE (EL-PC) PANEL	7
ELECTROLUMINESCENT PIEZOELECTRIC (ELP) PANEL	10
ELECTROLUMINESCENT TRANSMISSION LINE (EL-T) PANEL	12
DISCUSSION	13
TABLE I - Comparison of EL Panels and CRT Characteristics	15
BIBLIOGRAPHY	16
FIGURES	
1 Block Diagram of Single Electroluminescent Element	5
2 Complete Equivalent Circuit of Electroluminescent Element	5
3 Signal Distribution System for ELF Panel	6
4 Image Intensifier Panel (EL-PC)	9
5 Equivalent Circuit of Feedback Panel	10

Accession For	
NTIS GRA&I	<input checked="" type="checkbox"/>
DDC TAB	<input type="checkbox"/>
Unannounced	<input type="checkbox"/>
Justification	
By _____	
Distribution/ _____	
Availability Codes	
Dist	Avail and/or special
R	

BACKGROUND

The manifest advantages of the solid state pictorial display device - the electroluminescent (EL) panel - hold such apparent promise that it is essential that such a device be given serious consideration in the planning of advanced ASW integrated display systems. This thin, flat panel, which is vacuumless and rugged, adapts naturally to aircraft displays, and its compact form makes it ideal for use in the restricted space of the pilot's compartment. The EL panel is devoid of filaments and does not require high voltages. It is free from the hazards of high vacuum and should endure large acceleration stresses. Physical damage to one part of the panel will not result in "sudden death" as occurs with the cathode-ray tube.

WEPTASK No. RUSD3B001/2021/FOO4-02-001, specified as a detailed requirement, that a thorough investigation be made of all solid state techniques having application to ASW displays. This report was prepared to fulfill this requirement and is considered the first phase of this project. Other requirements call for the procurement of solid state devices together with their associated laboratory investigation. These requirements are incorporated as recommendations in this report and are considered as the next phase of the work. The preparation of performance specifications for developmental panel display will depend on the results obtained in phase II, together with further advances due to continuing research and development effort. The purpose of this study was to review the state-of-the-art of electroluminescent panels, with the object of determining the practicability of these panels for aircraft ASW displays of the type now using cathode-ray tubes.

The cathode-ray tube was chosen as a criterion for evaluating electroluminescent panel performance because both have light output, thus making possible a direct quantitative comparison of their functional performance. Furthermore, the functions performed by a cathode-ray tube display place greater demands upon EL panel performance than the functions of an electromechanical plotter. The assumption is that a panel capable of performing the functions of a cathode-ray tube display will also have the properties which will enable it to be used for the type of display now accomplished by electromechanical plotters.

The feasibility of replacing the cathode-ray tube display by an electroluminescent panel depends essentially on the answers to two questions. Can the electroluminescent panel perform as a picture device comparable to a cathode ray tube? Secondly, will the associated circuits for driving the EL panel and distributing the picture signal to the panel elements compare favorably in bulk and complexity to that required by the cathode-ray tube.

For the purpose of this report, these questions must be answered from the point of view of the potential EL screens in the near future, rather than as a comparison of the present status of EL panels. It is apparent that substantial improvement in performance of EL panels will be required before they can replace cathode-ray tubes as display devices.

There is a tendency to consider the problem of panel performance as separate from the electronics required to distribute the picture on the panel. However, any significant evaluation of the panel must take both of these problems into account. Panel performance and driving circuits are coupled in such a way that both problems must be solved for success. In the ASW tactical display, success is determined by reasonable approximation of the performance of a cathode-ray tube without significantly increasing the volume and weight of the driving circuits.

CATHODE - RAY TUBE PERFORMANCE

Typical of the cathode-ray tube indicators used in Navy airborne integrated ASW displays are the AN/ASA-16 and the AN/APA-125 equipments. In this study the weight and volume of the AN/APA-125 and the characteristics of its cathode-ray tube are used for the purposes of comparison.

The Dumont 10AKP7 magnetically focused and magnetically deflected cathode-ray tube is used as an indicator tube in this equipment. The significant screen characteristics of the 10AKP7 are given below:

Brightness: 72 foot-lamberts
 Resolution: 0.4 millimeter
 Contrast: 30-to-1
 Gray Scale: No data available
 Life: 500 hours negligible deterioration of screen characteristics
 Buildup: 5-to-1
 Persistence: 3 seconds

Physical Size and Weight of AN/APA-125 Indicator

	<u>Dimensions (in.)</u>	<u>Volume (cu ft)</u>	<u>Weight (lb)</u>
Indicator	20 x 12-3/4 x 28	4.1	114
Power Supply	13 x 10-3/4 x 19-1/4	1.6	40
Control Tray	22-1/2 x 7 x 9-3/4	0.9	12
	Total	<u>6.6</u>	<u>166</u>

D I S P L A Y R E Q U I R E M E N T S

The display system accepts tactical information from various detection and navigation systems in the form of electrical signals. These data are displayed symbolically as a plot on the face of a cathode-ray tube. The visible electronic plot is a graphic representation of the physical problem of locating, tracking, and attacking an undersea target. The plot changes continuously in response to the changing variables of the problem. Since the cathode-ray tube display is dynamic, being continuously and instantaneously updated, data to be preserved for future use must be stored in a memory device external to the cathode-ray tube.

Any substitute for a cathode-ray tube display must be capable of:

1. Accepting as input signals the electrical analogues of the problem variables.
2. Presenting these factors as a dynamic continuously changing display.
3. Selective erasing of unwanted information.
4. Changing scale instantaneously.

In addition it is desirable to have variable persistence (storage time) and random access to a given point on the panel surface. These functions must be accomplished with photometric and optical performance comparable to that of present cathode-ray tube displays.

The ultimate objective is a high-speed real-time display with a fast-scan raster (commercial TV rate). A more limited objective is a low-speed real-time display presenting information via a slow-scan raster (radar rates).

E L E C T R O L U M I N E S C E N T F E R R O E L E C T R I C
(E L F) P A N E L

The electroluminescent ferroelectric display panel is a multi-element panel consisting of an array of electroluminescent cells in matrix form. Each one of these cells is essentially a capacitor whose dielectric contains the phosphor which emits light when subjected to the alternating electric field. In the practical application to display panels at least one of the capacitor plates is a transparent conductor.

The distinctive feature of the ELF panel is that each EL element has a ferroelectric capacitor network to control the alternating current exciting the EL phosphor. This nonlinear circuit element has a capacitance that varies as a function of the d-c voltage applied across its plates. This characteristic controls the light output of the cell in accordance with electrical input signals.

Each element has in its structure the control circuit network, decoupling network, and element switch. All these networks are combined in the form of solid state microcircuit. The cells are arranged in an orthogonal array with a common connection to each cell in each row (y) and in each column (x). The total number of conductors is the product of the x and y rows and columns. At the present state-of-the-art this is 16 conductors per inch of panel width and length. Figure 1 is a block diagram showing the network components of a single EL element. The complete equivalent circuit of this element is shown in figure 2.

DISTRIBUTION OF SIGNAL TO ELF PANEL

Brightness modulation of panel elements can be accomplished by distributing the control signal sequentially to each element or to a line of elements at a time. Figure 3 illustrates an experimental matrix distribution system for the line-at-time application of the brightness modulating signal. The signals representing a horizontal line of the image to be displayed are stored in the column register. These signals are applied to all the columns by the x drivers, but the row selector actuates the appropriate row through the y driver and this transfers the brightness voltage from the column register to that row.

PANEL PROBLEMS

Some of the problems which characterize the ELF panel are as follows:

1. Brightness: A demonstration display panel had adequate visibility in low ambient light intensity, but suffered substantially in a normally lighted room. At 400 cycles, the electroluminescent highlight brightness was 10 foot lamberts. Continuing development effort indicates that double the present brightness level is feasible.
2. Resolution: The ELF panel is designed to have a geometrical resolution of 16 lines per inch. However, this resolution is somewhat reduced because of optical and electrical fringing. Interaction between adjacent elements depends upon structural details of the element microcircuit. A change in brightness of full-on to full-off affects the "on" brightness of an adjacent cell by 2.3 db.
3. Humidity: Present ELF cells perform well at 1 percent relative humidity, and satisfactorily up to 30 percent relative humidity. Between 60 and 90 percent relative humidity, cell life is shortened by a factor of 1000. Protective coating is being pursued as an answer to this problem.
4. Control Voltage Sensitivity: Brightness in the EL cell is controlled by the application of a d-c potential to the EL control circuit. A rather large signal of 200 volts dc is required to effect luminance ratios in the range from 50-to-1 to 100-to-1. Development of dielectric material for nonlinear capacitors indicates a potential reduction of the 200-volt control signal to 40 volts or less.

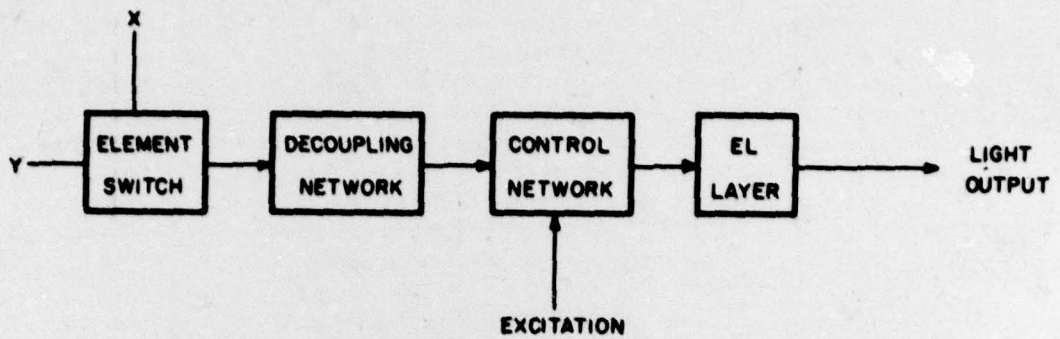

FIGURE 1 - Block Diagram of Single Electroluminescent Element

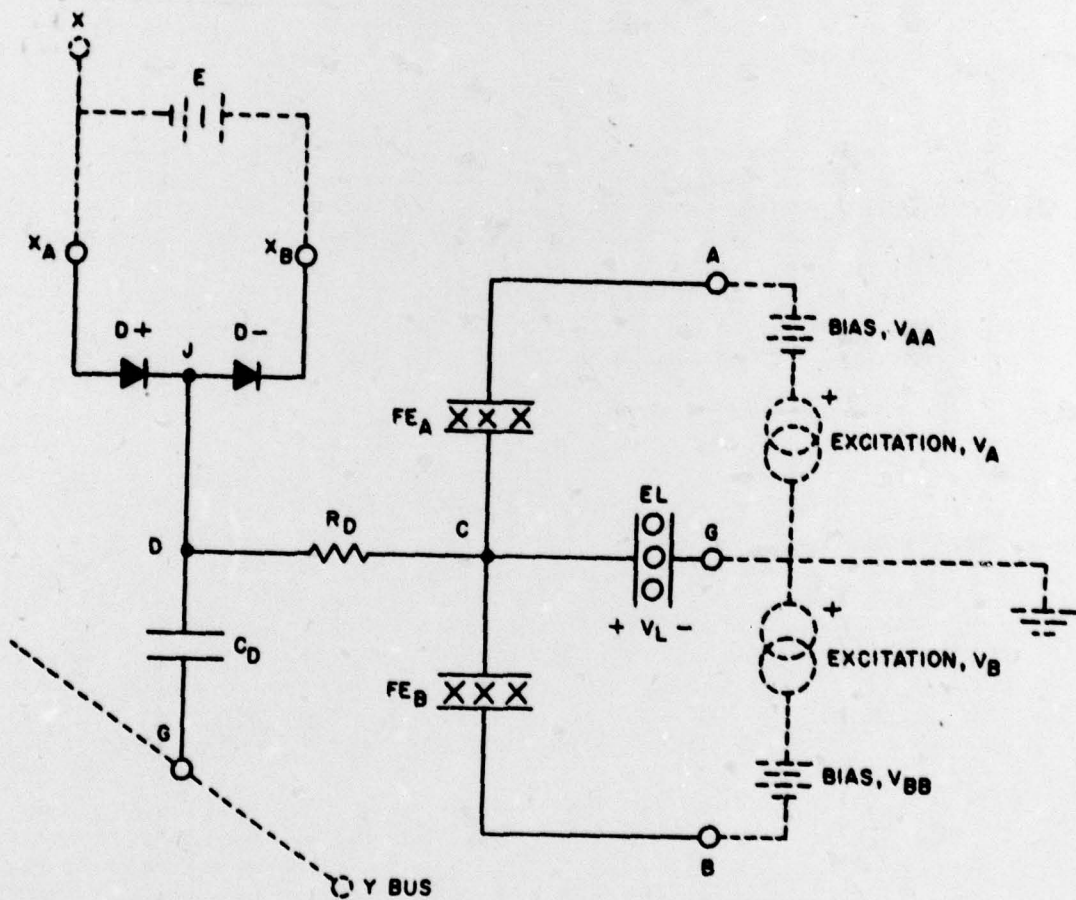

FIGURE 2 - Complete Equivalent Circuit of Electroluminescent Element

resistance of spark gap switches is expected to increase panel storage time to 2 hours or more.

PERFORMANCE

The screen characteristics of a demonstration ELF panel at its present state of development is given below:

Brightness:	10 foot-lamberts
Resolution:	16 lines/inch, diagonal of square element = 22 mm
Contrast:	40-to-1 to 90-to-1
Gray Scale:	5 steps
Life:	2500 hours (to half brightness point)
Persistence (storage time):	5 seconds
Buildup (response time):	No data available
Switching Speed:	150 us/line (128 elements per line)

The volume and weight of the ELF peripheral electronics equipment is not known. Laboratory equipment indicates that the size would be larger than that for cathode-ray tube equipment.

It appears feasible that both brightness and resolution can be improved by a factor of 2. Storage times can be increased by use of ionic switch (spark gaps) up to 1 hour. Improvements in ferroelectric materials should reduce the required control voltage from 200 to 40 volts or less.

ELECTROLUMINESCENT PHOTO-CONDUCTIVE
(EL-PC) PANEL

The EL-PC panel differs from other electroluminescent panels in that the input signal is light, X-ray, or infrared radiation rather than an electrical signal. The method of controlling the output light intensity of the phosphor is by resistance change in a photo-conductor element when it is exposed to light. The light-sensitive resistance is in series with the electroluminescent capacitor and thereby controls the exciting voltage applied to the phosphor.

One type of photo-conductive panel is the image intensifier. The simplest construction of this type is a sandwich of a transparent conductive layer followed by a layer of photo-conductive material, a layer of electroluminescent phosphor, and a final layer of transparent conductive coating. When an a-c voltage is applied to the transparent conductors and a portion of the photo conductor is illuminated, the resistance of the photo-conductive layer in that area decreases. Through the series circuit arrangement, the current through the electroluminescent layer increases in the illuminated portion causing it to emit light at a greater intensity.

A more refined image intensifier panel has the photoconduction layer cut into parallel V-type ridges with the conducting lines on the top of the groves. A current diffusing layer and a light opaque layer are added between the photo conductor and electroluminescent layer as shown in figure 4.

An extension of the image intensifier is the feedback light amplifier panel. In the conventional image intensifier, light feedback is prevented by an opaque shield between the photosensitive layer, and the electroluminescent layer. By providing light feedback from the electroluminescent element to the photo conductor, an illuminated element may be kept on for an indefinite time after the input light signal has been removed. In this mode of operation, a transient picture signal may be stored for any desired period.

Figure 5 is the equivalent circuit for a feedback panel element. The light feedback circuit is isolated from the light output by a separate photoconductor element. If the power supply V_2 is open circuited, the feedback circuit becomes inoperative and the stored picture is erased. In this condition, the bistable or storage mode is eliminated and the panel becomes a conventional image intensifier.

PANEL PROBLEMS

Some of the problems connected with the EL-PC panel include dielectric breakdown, low brightness, crosstalk, and poor resolution, with spreading being the most important, as follows:

1. Spreading: There is a tendency in the feedback panel for illuminated elements to cause adjacent elements to light by optical and electrical leakage. Considerable improvement has been obtained by the incorporation of light opaque layers and electrical insulators into the physical design of the panel. A laboratory model tested in 1959 showed no perceptible spreading 30 minutes after the image had been registered.

PANEL PERFORMANCE

	<u>EL-PC Feedback (Storage) Panel</u>	<u>EL Image Intensifier</u>
Brightness:	0.5 foot-lamberts	28 foot-lamberts
Resolution:	40 lines/inch	40 lines/inch
Contrast:	No data	No data
Gray Scale:	2 steps	(TV quality)
Life:	No data	No data
Persistence (Storage Time):	Indefinite	1 millisecond
Response Time:		0.1 to 3 seconds

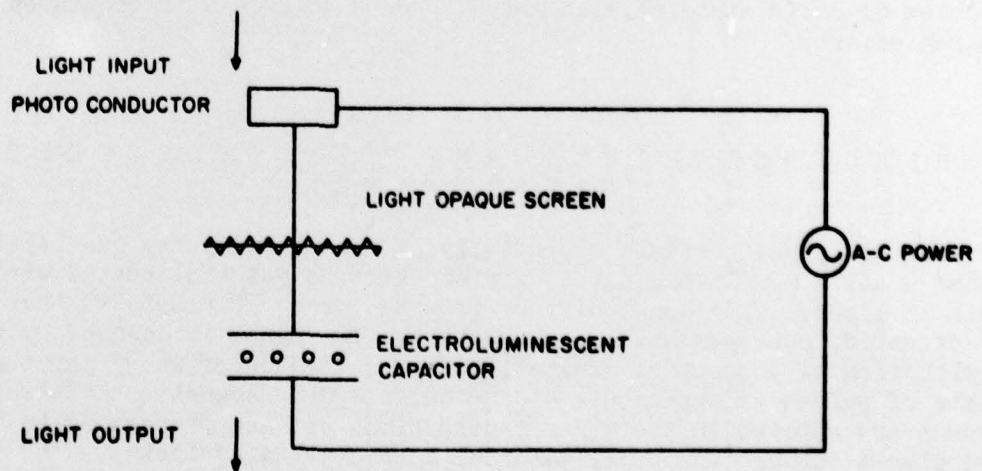
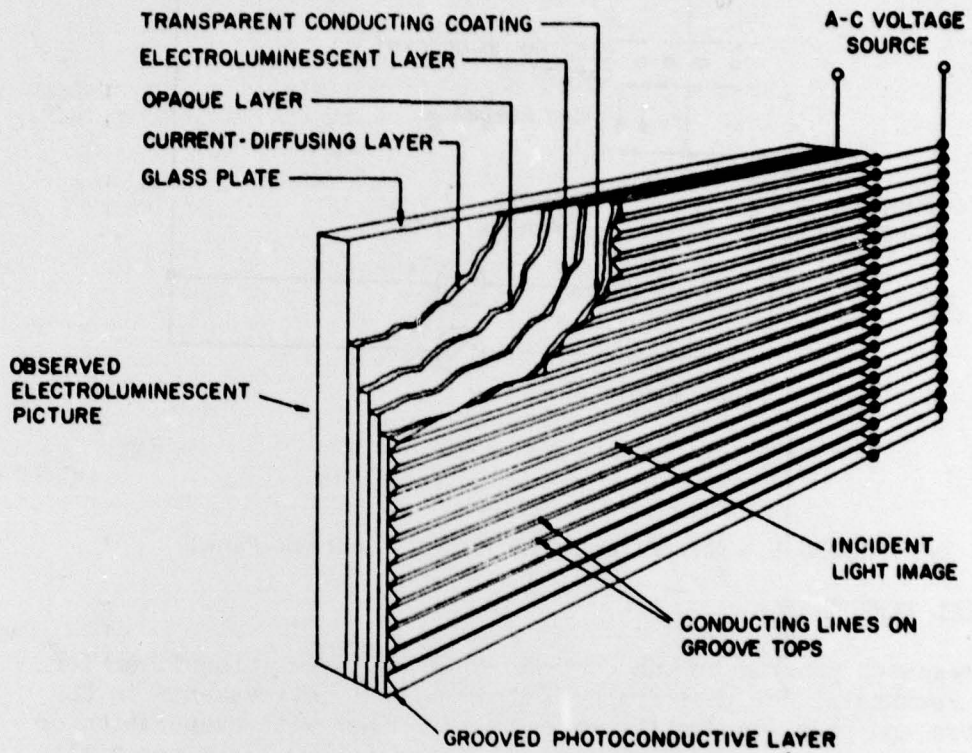

FIGURE 4 - Image Intensifier Panel (EL-PC)

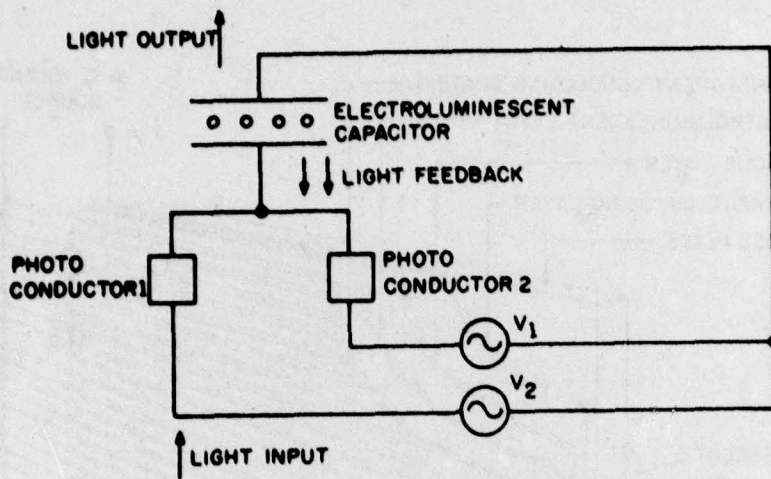

FIGURE 5 - Equivalent Circuit of Feedback Panel

POTENTIAL PERFORMANCE

A research program by one contractor on an image intensifier for aerial reconnaissance photography indicates that improvements in EL phosphors and photo-conductive materials together with evaporation or spraying techniques could increase resolution to 100 lines per millimeter putting it on a par with the resolution of photographic film. The improvement of dark current and response time of photo conductors is a problem of solid state physics which appears soluble with continued research effort.

ELECTROLUMINESCENT PIEZOELECTRIC
(ELP) PANEL

The ELP panel consists essentially of two thin layers, one layer being a solid monolithic sheet of piezoelectric material coated with a thin EL layer. This panel differs from the other EL panels in that it is of solid, non-segmented, construction. The panel is scanned by the application of acoustical excitation from a transducer whose input consists of pulses of supersonic electrical energy. Acoustic shock-wave fronts are applied in the x and y directions and are propagated in these two planes through the panel material at a constant velocity.

Associated with the shock waves or mechanical distortion of the panel medium is an electric field from the piezoelectric effect. At any point of intersection of these two wave fronts, the electrical field adds in such a way that the field intensity at that point is the sum of the two pulses of the intersecting wave fronts. The brightness versus voltage

characteristics of the EL layer is designed so that it luminesces under this electric field condition. At any instant the location of the point on the panel to be excited into luminescence is determined by the intersection of the two traveling wave fronts. The luminous point travels as the two wave fronts and their intersection move. The relationship between the starting times of the x and y wave fronts determine the point or line described on the EL surface. By appropriate arrangement of this time relationship, a raster-type scan is generated to cover all points on the surface in sequence.

Intensity modulation is accomplished by applying the modulating voltage to an electrode which covers the back area of the panel. The modulating voltage (video) at any instant is effective on the point which is illuminated by the intersection of the acoustic wave fronts.

PERFORMANCE

Although there has been a successful laboratory demonstration of the concept and basic operating principles of this panel by its inventors, little quantitative performance data are available. The laboratory demonstration showed the ability of the unit to generate a Lissajou circle from 1000-cycle sinusoids in a darkened room. This experiment showed that the panel has a random access capability. Brightness modulation of a 15-kilocycle scan line at a frequency of 1.5 megacycles was also demonstrated. However, the brightness was low and the trace had the appearance of being out-of-focus and fuzzy.

PROBLEMS

Although the experimental unit demonstrated the feasibility of a novel and apparently very simple means of signal distribution on an EL panel, a number of significant problems are indicated by this preliminary work:

1. Focus must be improved; it is related to the propagation (scattering) of the supersonic waves in piezoelectric (ceramic) media.
2. Brightness must be increased. Phosphor development is needed to improve the response to fast pulses. Development of both piezoelectric and electroluminescent materials for optimizing energy transfer between the two layers could improve the light output.
3. Contrast ratio needs improvement. Research in nonlinear resistance layers is expected to produce improvement in contrast and lessen demands on video driving power.

In principle the electroluminescent piezoelectric panel presents a neat and simple solution to the problem of picture distribution. Realization of its full possibilities depend to a large extent upon the success of research in materials.

An analysis is needed of the physics of supersonic propagation in flat solid piezoelectric media to determine the nature and measure of basic limitations on resolution and focus. Width of the shock wave and the scattering phenomena appear to be two factors bearing upon the resolution and focus problem.

ELECTROLUMINESCENT TRANSMISSION LINE
(EL-T) PANEL

One approach to the EL picture panel uses a conventional crossed grid panel with the x and y lines connected along the length of an r-f transmission line in each axis. The transmission line is operated as a resonant line so that transmitted pulses are reflected from the receiving end back along the line. If a second pulse is sent down the line after the first is underway, it coincides at some point on the transmission line with the reflected pulse coming back. At this point the pulses combine to produce twice the voltage amplitude of a single pulse, the panel grid wire connected to this point on the line sees an instantaneous increase in voltage and this wire is "switched" on. In this manner any one of the crossed grid wires is switched on electronically at very high speed. The particular line to be switched is determined by the time relationship between the launching of the first and second pulses. The problem of switching reduces to a matter of generating pulse pairs with a time separation corresponding to the location of the wire to be switched.

By incorporating the shunt capacitance of the EL elements (capacitance between grid wires) as part of reactive elements of the transmission line switch, these losses are removed from the load, thereby reducing the power demands on the switch.

Brightness modulation is accomplished by varying the amplitude of the individual pulses as they are sent into the switching transmission line.

An alternative method of element switching is the use of a planar panel with transparent area electrodes instead of crossed grids. The whole panel is used as a transmission line. An electromagnetic wave is introduced into the panel, edge on. The field propagates across the surface of the panel just as a pulse traveling along the transmission line. The double pulse method is used as before, and the electric field doubles at the point where the incident pulse coincides with the reflected pulse. A similar pulse pair is introduced into the adjacent edge. Field increase of four times the initial amplitude occurs where the two fields intersect. This causes the elemental area of EL phosphor located at this intersection to luminesce. Instead of using fast discrete pulses, peaked continuous waves may be used as an alternative. Each method has its particular advantages or disadvantages. Brightness control is effected by modulation of the input pulse excitation to the panel at video rates.

PROBLEMS

Although there is no evidence of an actual laboratory demonstration of the panel as a picture display, laboratory and analytical work has demonstrated the validity of the operating principles. Anticipated problem areas are in contrast, brightness, and response of the phosphor to the fast pulses required for transmission line switching.

Contrast is limited by the cross-talk between the selected coordinate and the other coordinates which it intersects. As in the other panels, the answer seems to be in obtaining a brightness voltage characteristic which is nonlinear. Due to the fact that a voltage equal to one half the amplitude switching pulse exists between an excited grid wire and other unexcited grids which it intersects, the phosphor should not emit light at 1/2 voltage or less. Such a threshold is necessary to avoid degradation of contrast by spurious excitation of adjacent grid intersections.

Brightness and phosphor response to fast pulses loom as the key problems in the development of a practical panel.

POTENTIAL

The solid state display panel seems to have solved the problem of high-speed switching and modulation. Electronic circuitry to drive the panel is within the scope of present state-of-the-art. The complexity and required physical size for this circuitry should compare favorably with cathode-ray tube arrangements.

Barring the development of serious problems with the transmission line switching, the success of this panel depends mainly upon the development of improved electroluminescent phosphors. The acid test of the idea awaits the fabrication of an actual picture panel and a demonstration of its performance.

DISCUSSION

At the present stage of research and development in the field of electroluminescent displays, there has been no actual demonstration of a fully operating picture panel. The principles involved in a number of different approaches to such a system have been formulated and in some cases verified by laboratory experiment. In the absence of a demonstration of EL panel as an overall picture system, it is speculative to evaluate the different approaches with any degree of validity.

The main approaches to the solution have recognized three major problem areas, namely, brightness, resolution, and complexity of the scanning system. Unfortunately, the demands of these factors are conflicting in the systems thus far proposed. The attempt to solve these problems has concentrated effort in research and development on EL phosphors and in the development of a fast method of electronic switching with minimum complexity.

In the field of phosphors, attempts are being made to increase the brightness and operating life, to provide a nonlinear voltage-brightness characteristic that has a definite threshold, to lower the required exciting voltage, to improve phosphor response to fast pulse, and to minimize the adverse effects of humidity on phosphor performance.

A major problem with the use of EL panels as picture displays is the rapid distribution of the picture signal on the face of the panel. This appears to be the most formidable obstacle to the realization of a practical solid state picture panel. However, independent approaches to the solution of this problem by two industrial concerns appear very promising. Both of these approaches employ a variation of transmission line phenomena which is used to position an intensified electric field rapidly across a small defined element of the EL phosphor. The rapid positioning of this spot is programmed to trace out a raster in a manner similar to television scanning.

One method utilizes the propagation of a supersonic shock wave in a piezoelectric panel layer, while the other method uses r-f pulse propagation in a lumped parameter delay line. The r-f pulse propagation method can also excite the panel conductors directly, thereby using the panel itself as a transmission line.

The theory of operation of the piezoelectric EL panel has been demonstrated in rudimentary form. While this demonstration indicated workability of the idea, further studies are needed on the propagation of waves in the piezoelectric ceramic medium to determine the fundamental limitations on resolution and focus. The low brightness level exhibited in the demonstration will have to be materially improved.

A demonstration of the r-f pulse propagation panel as a picture display has not been made. However, the operation of transmission line switching has been accomplished experimentally. Phosphor brightness and phosphor response to the fast pulses required are problems.

The ELF panel, while achieving considerably higher brightness than the above-mentioned panels, is deficient in resolution and requires considerable complexity in the electronics for signal distribution. This panel has been subjected to photometric tests, but has not been demonstrated as a picture display.

T A B L E I
COMPARISON OF EL PANELS AND CRT CHARACTERISTICS

Performance Characteristic	10AKP7 Cathode-Ray Tube	ELF Panel	EL Image Intensifier	EL-PC Feedback Storage Panel	Piezo-Electric EL Panel	R-F Pulse Propagation EL Panel
Brightness	72 ft-lamberts	10 ft-lamberts	28 ft-lamberts	0.5 ft-lamberts	*	*
Resolution	0.4 mm	16 lines/in. 22 mm	40 lines/in.	40 lines/in.	*	*
Contrast	30 to 1	40 to 1 to 90 to 1	*	*	*	*
Gray Scale	*	5 steps	TV Quality	2 steps	*	*
Persistence	3 sec	5 sec	0.001 sec	infinite	*	*
Response Time	*	*	0.1 to 3 sec	*	*	*
Switching Speed	*	150 per sec per line 128 elements per line	*	*	*	*
Life	500 hr to negligible deterioration of screen characteristics	2500 hr to 1/2 brightness point	*	*	*	*

NOTE: * No data available.

B I B L I O G R A P H Y

- (a) General Characteristics and Data Sheet, 10AKP7, Cathode Ray Tube; A. B. Dumont Laboratories, Clifton, N. J.
- (b) Internal Engineering Report (unpublished); A. B. Dumont Laboratories, Clifton, N. J.
- (c) Spec No. MIL-I-19165B(WEP), "Indicator Group AN/APA-125A"
- (d) Sack, E. A.; Advances in Screen Structure and Data Distribution for the ELF Display System, Westinghouse Scientific Paper 410 FF298-P1
- (e) Sack, E. A.; ELF - A New Electroluminescent Display, Pro. I.R.E., Oct 1958
- (f) NAVAIRDEVCEEN Trip Report on Ninth ELF Coordination Meeting, Westinghouse Research Laboratories, Pittsburgh, Pa, 13 Jul 1960
- (g) Josephs, J. J.; A Review of Panel Type Display Devices, Lincoln Laboratory, M.I.T., Memo of 4 Mar 1958
- (h) Josephs, J. J.; A Review of Panel Type Display Devices (Revised 18 Jan 1960), Pro. I.R.E., Aug 1960
- (i) Solid State Image Intensifier, Radio Corporation of America, Electron Tube Division, Harrison, N. J.
- (j) Kazan, B. and Nicoll, F. H.; An Electroluminescent Light Amplifying Picture Panel, Pro. I.R.E., Dec 1955
- (k) Kazan, B.; A Feedback Light - Amplifier Panel for Picture Storage, Pro. I.R.E., Jan 1959
- (l) Bartels, B. E.; Presentation of a New Concept for A Solid State, Self-Scanning Display Panel, General Telephone and Electronics Laboratories, 19 Oct 1960
- (m) A Solid State TV Tube Internal Report, Kaiser Aircraft and Electronics, Palo Alto, California

U. S. Naval Air Development Center, Johnsville, Pa.
Anti-Submarine Warfare Laboratory

I. Uphoff, F. B.

PHASE REPORT, STATUS OF ELECTROLUMINESCENT PICTURE DISPLAY PANELS; by F. B. Uphoff; 17 Nov 1961: 20 P; Report No. MADC-64-6108; WEFTASK RUSO3001/2021/FOO4-02-001. Report: UNCLASSIFIED

The state-of-the-art of electroluminescent picture display panels was studied to determine the practicability of these panels for aircraft ASW displays now using cathode-ray tubes. Ferroelectric, photo-conductive, piezoelectric, and trans-mission-line panels were investigated. None of these panels have been developed to the stage where they can be considered for use in ASW display devices. However, the rapid advances in the developmental work give good cause for optimism.

U. S. Naval Air Development Center, Johnsville, Pa.
Anti-Submarine Warfare Laboratory

I. Uphoff, F. B.

PHASE REPORT, STATUS OF ELECTROLUMINESCENT PICTURE DISPLAY PANELS; by F. B. Uphoff; 17 Nov 1961: 20 P; Report No. MADC-64-6108; WEFTASK RUSO3001/2021/FOO4-02-001. Report: UNCLASSIFIED

The state-of-the-art of electroluminescent picture display panels was studied to determine the practicability of these panels for aircraft ASW displays now using cathode-ray tubes. Ferroelectric, photo-conductive, piezoelectric, and trans-mission-line panels were investigated. None of these panels have been developed to the stage where they can be considered for use in ASW display devices. However, the rapid advances in the developmental work give good cause for optimism.

U. S. Naval Air Development Center, Johnsville, Pa.
Anti-Submarine Warfare Laboratory

I. Uphoff, F. B.

PHASE REPORT, STATUS OF ELECTROLUMINESCENT PICTURE DISPLAY PANELS; by F. B. Uphoff; 17 Nov 1961: 20 P; Report No. MADC-64-6108; WEFTASK RUSO3001/2021/FOO4-02-001. Report: UNCLASSIFIED

The state-of-the-art of electroluminescent picture display panels was studied to determine the practicability of these panels for aircraft ASW displays now using cathode-ray tubes. Ferroelectric, photo-conductive, piezoelectric, and trans-mission-line panels were investigated. None of these panels have been developed to the stage where they can be considered for use in ASW display devices. However, the rapid advances in the developmental work give good cause for optimism.

U. S. Naval Air Development Center, Johnsville, Pa.
Anti-Submarine Warfare Laboratory

I. Uphoff, F. B.

PHASE REPORT, STATUS OF ELECTROLUMINESCENT PICTURE DISPLAY PANELS; by F. B. Uphoff; 17 Nov 1961: 20 P; Report No. MADC-64-6108; WEFTASK RUSO3001/2021/FOO4-02-001. Report: UNCLASSIFIED

The state-of-the-art of electroluminescent picture display panels was studied to determine the practicability of these panels for aircraft ASW displays now using cathode-ray tubes. Ferroelectric, photo-conductive, piezoelectric, and trans-mission-line panels were investigated. None of these panels have been developed to the stage where they can be considered for use in ASW display devices. However, the rapid advances in the developmental work give good cause for optimism.

