

AD-A074 135

NAVAL RESEARCH LAB WASHINGTON DC
RADIO CONTROLLED WATER SAMPLING BUOY. (U)
DEC 63 A D SWANSON, R C BECKETT
NRL-MR-1480

F/G 8/10

UNCLASSIFIED

NL

| OF |
ADA
074135



END
DATE
FILMED
10-79
DDC

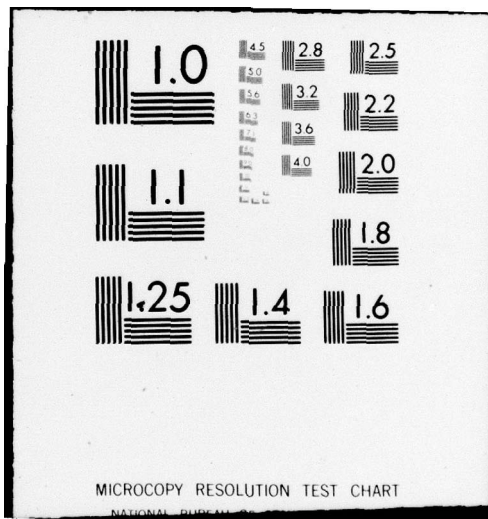

(UNCLASSIFIED)

SECURITY CLASSIFICATION OF THIS PAGE (When Data Entered)

1ms

AD A 074135

| REPORT DOCUMENTATION PAGE | | READ INSTRUCTIONS BEFORE COMPLETING FORM |
|---|-----------------------|---|
| 1. REPORT NUMBER NRL #1480 | 2. GOVT ACCESSION NO. | 3. RECIPIENT'S CATALOG NUMBER |
| 4. TITLE (and Subtitle) RA. CONTROLLED WATER SAMPLING BUOY | | 5. TYPE OF REPORT & PERIOD COVERED Memo Report |
| 7. AUTHOR(s) Swanson, Arthur D. and Beckett, Robert C. | | 6. PERFORMING ORG. REPORT NUMBER |
| 9. PERFORMING ORGANIZATION NAME AND ADDRESS Naval Research Laboratory Washington, D.C. | | 8. CONTRACT OR GRANT NUMBER(s) Nonr-266(84) |
| 11. CONTROLLING OFFICE NAME AND ADDRESS Office of Naval Research, Code 220 800 North Quincy St. Arlington, VA 22217 | | 10. PROGRAM ELEMENT, PROJECT, TASK AREA & WORK UNIT NUMBERS |
| 14. MONITORING AGENCY NAME & ADDRESS (if different from Controlling Office) LEVEL II | | 12. REPORT DATE DEC 63 |
| | | 13. NUMBER OF PAGES |
| 16. DISTRIBUTION STATEMENT (of this Report) Approved for public release; distribution unlimited 12) 14 p | | 15. SECURITY CLASS. (of this report) UNCLAS |
| 17. DISTRIBUTION STATEMENT (of the abstract entered in Block 20, if different from Report) 10) Arthur D. /Swanson Robert C. /Beckett | | 15a. DECLASSIFICATION/DOWNGRADING SCHEDULE |
| 18. SUPPLEMENTARY NOTES 14) NRL-MR-1480 9) Memorandum repts | | |
| 19. KEY WORDS (Continue on reverse side if necessary and identify by block number) 16) F00103, F00003 | | |
| 20. ABSTRACT (Continue on reverse side if necessary and identify by block number) 17) SF0010313, RF0000344 | | |

DDC FILE COPY

DDC RECEIVED
SEP 20 1979
RECEIVED
C

251950

UNCLASSIFIED

COLUMBIA UNIVERSITY
WESLEYAN LABORATORIES
CONTRACT Nonr-266(04)
NRL Memorandum Report 1480

RADIO CONTROLLED WATER SAMPLING BUOY

Arthur D. Swanson
Robert C. Beckett

SOUND DIVISION

December 1963



U. S. NAVAL RESEARCH LABORATORY
Washington, D.C.

AD A 074135

DDC FILE COPY

79 09 17 046

550 - 1 - 1

COLUMBIA UNIVERSITY
~~NTIS LIBRARIES~~
CONTRACT Nonr-266(84)

CONTENTS

| | |
|---|----|
| Abstract | ii |
| Problem Status | ii |
| Authorization | ii |
| | |
| RADIO CONTROLLED WATER SAMPLING BUOY | 1 |
| | |
| ACKNOWLEDGMENT | 2 |

| | |
|--------------------|-------------------------------------|
| Accession For | |
| NTIS GRA&I | <input checked="" type="checkbox"/> |
| DDC TAB | <input type="checkbox"/> |
| Unannounced | <input type="checkbox"/> |
| Justification | |
| By _____ | |
| Distribution/ | |
| Availability Codes | |
| Dist | Avail and/or special |
| A | |

ABSTRACT

↙ This report describes a specially designed ocean surface sampling buoy that is operated by remote control. A four-channel radio transmitter and receiver is used with additional electronics to operate this buoy at approximately 1000 yards. The buoy has a capacity for collecting up to 8 liters of surface water. A method of deploying the buoy from a small boat is discussed along with a flash bulb triggering system that gave a very high efficiency rating. ↗

PROBLEM STATUS

This report describes one aspect of the problem. Work on other aspects is continuing.

AUTHORIZATION

NRL Problem S01-18
Projects SF 001-03-13-8136 and
RF 000-03-44-4065

RADIO CONTROLLED WATER SAMPLING BUOY

A need for remotely controlled sampling of ocean surface water has prompted development of a means of obtaining an uncontaminated surface sample at sea. Other sampling methods require the close proximity of ships which add contaminant material to the ocean surface during the surface sampling operation. It was decided that a citizens band, four-channel transmitter and receiver would be best suited for radio controlled sampling. Four channels would be sufficient to accomplish the desired control as to the amount of sample collected.

Figures 1 and 2 show the external view of the two working units constructed, which had capacities of 8 and 4 liters respectively. The units were made of stainless steel in the shape of a cylindrical buoy. A spar is attached to the bottom to stabilize the buoys while in the water. The buoys were made waterproof and coated with Epoxy resin to keep the stainless steel from interacting with the water around them. A coat of Da-Glo Red was applied before resin to the outside of the buoys for easy visibility.

The control system consisting of the radio receiver and batteries (Fig. 3) are in a carriage in the lower part of the buoys. Figure 4 shows the block diagram of the electronics. The receiver is an Orbit type model-airplane control unit with four channels. Each channel vibrated a reed which closed a relay whose contact points connected to the triggering system of the buoy. In this manner a sample could be collected upon command from the transmitter, pictured at the left in Fig. 2. The usual range used on the open ocean was 1000 yards.

The triggering system consists of a specially made clip spring crimping the intake hoses from two sample bottles (Fig. 5). The spring clip is held closed by a strip of polyethylene, 1 mil thick and approximately 15 cm long, wrapped around two photographic flash bulbs. The flash bulbs are connected across a 1-1/2-volt battery via the contact points of the relay in the control system.

Upon command from the transmitter the control system will close the relay contact points, thereby firing the flash bulbs. The heat from the flash bulbs will melt the polyethylene and release the spring clip, allowing the vacuum in the sample bottles to take in a sample. In this manner a sample of surface water can be taken through the intake hoses with small Styrofoam buoys attached on the end as shown in Fig. 2.

Preparation of the buoys for sampling required wrapping the polyethylene around the flash bulbs and spring clips of the triggering system. A jig was devised to aid in this function, thereby reducing the total time of preparation by 20 to 30 minutes. On the right of Fig. 6 is the jig set up. On the left of Fig. 6 is an example of a cocked trigger.

The buoys are deployed by lowering them over the side of a small boat and allowing the boat to drift away a reasonable distance to a prearranged station. After the buoys have taken in the necessary water samples, the boat will retrieve them and return them to the laboratory for analysis.

On several field trips, the buoys were 100% efficient in collecting a full capacity of water. Further operational improvements are being made.

ACKNOWLEDGMENT

The authors express their gratitude to Mr. A. J. Hiller for his technical advice on the design features, to Mr. W. B. Nefedov for his helpful suggestions, and to all those who participated in the field tests under adverse field conditions.

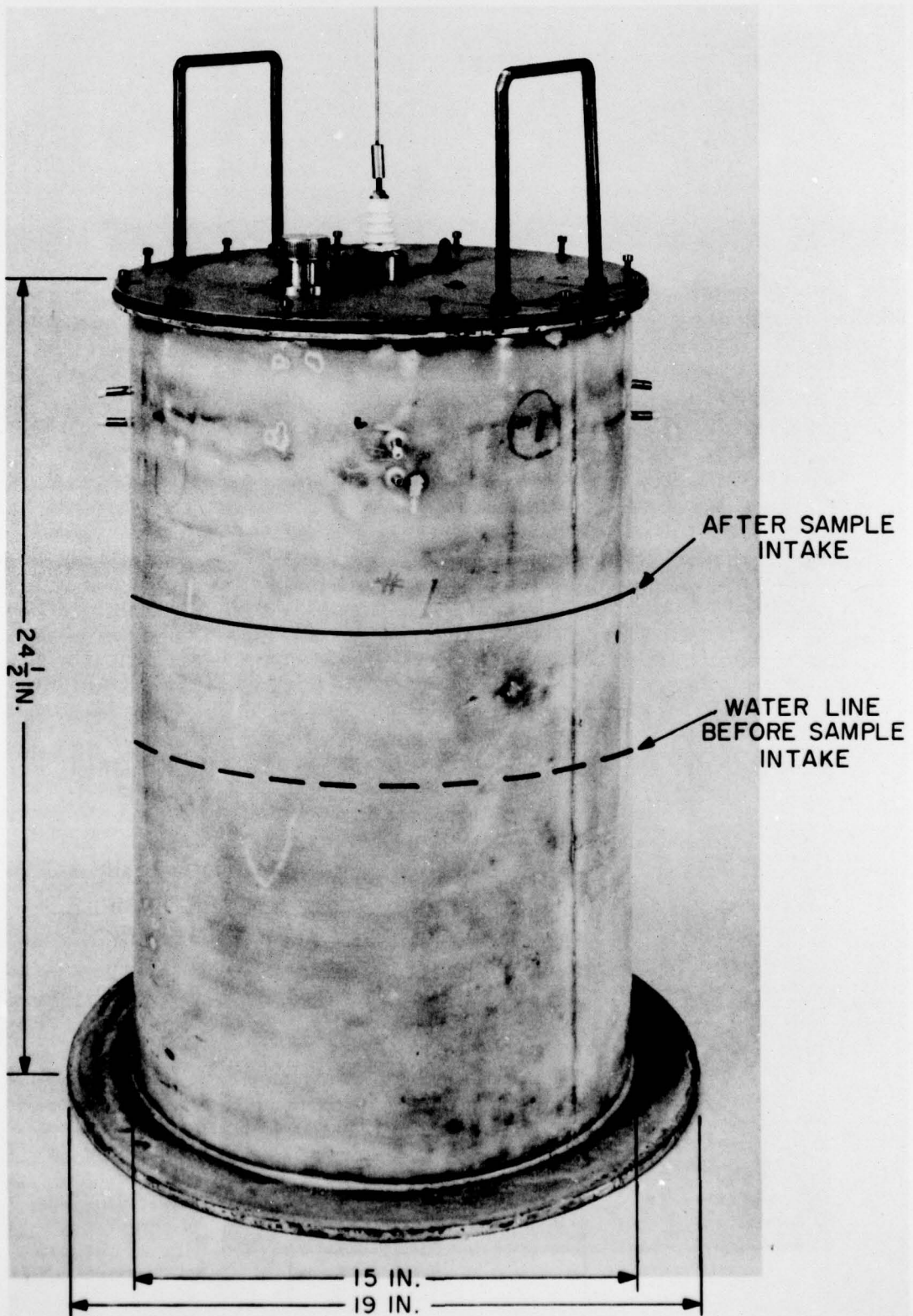

Fig. 1 - Eight-liter sampling buoy

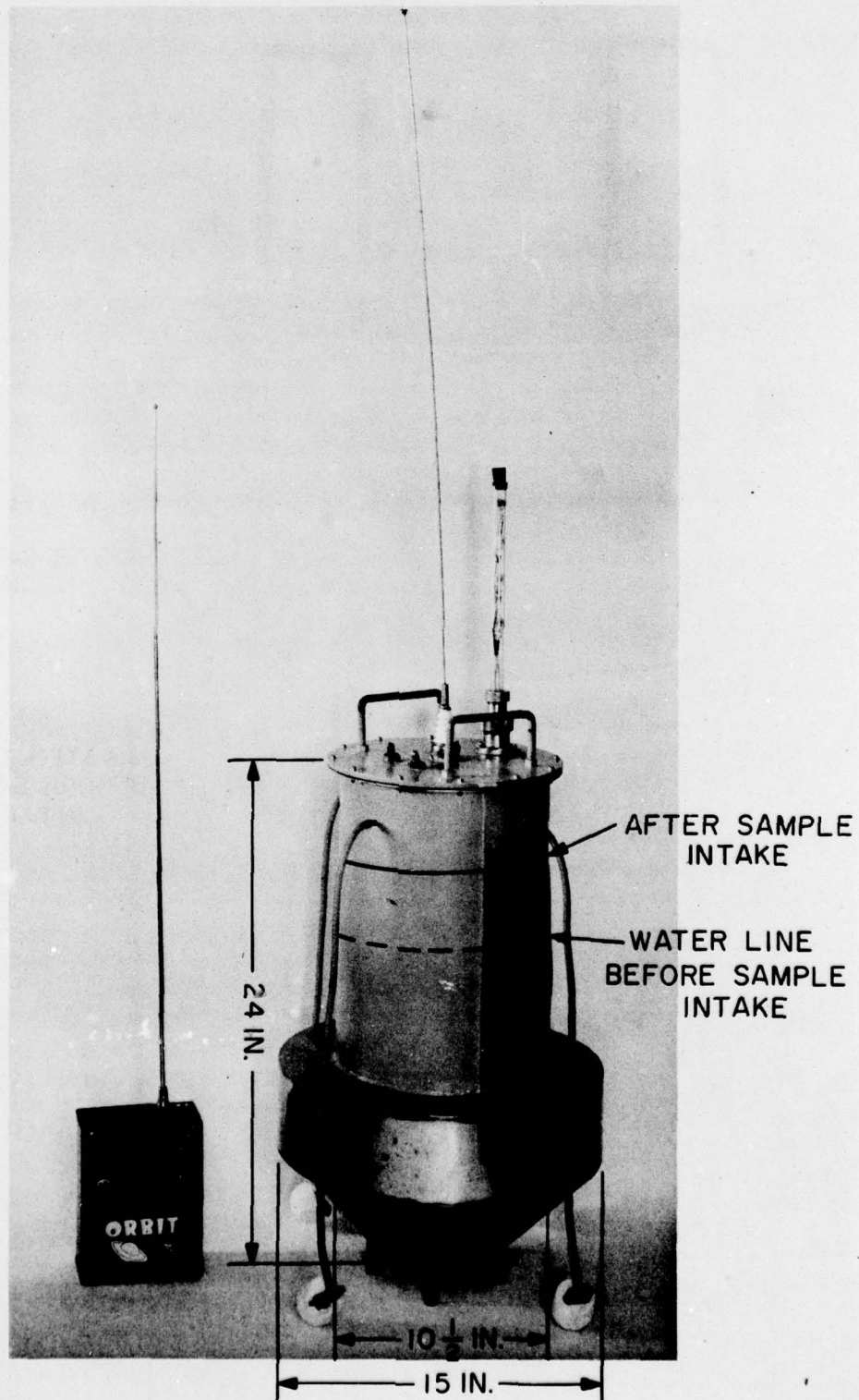

Fig. 2 - Four-liter sampling buoy

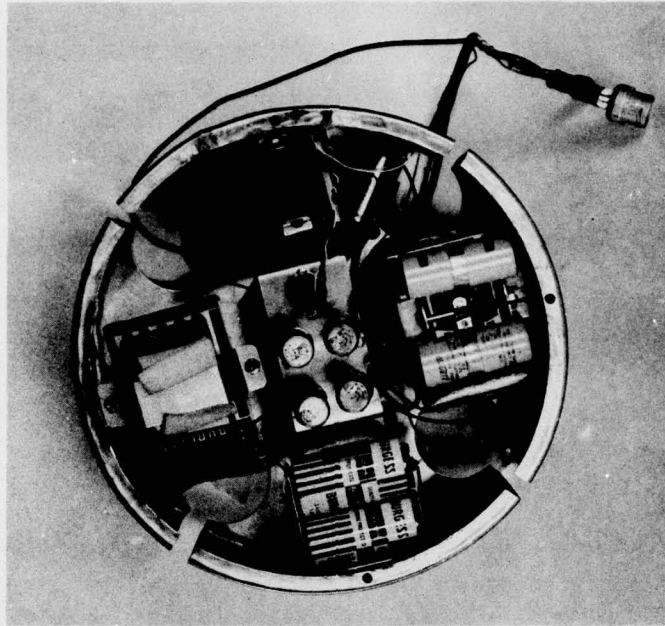

Fig. 3 - Receiver and batteries to be placed in the lower part of the buoy

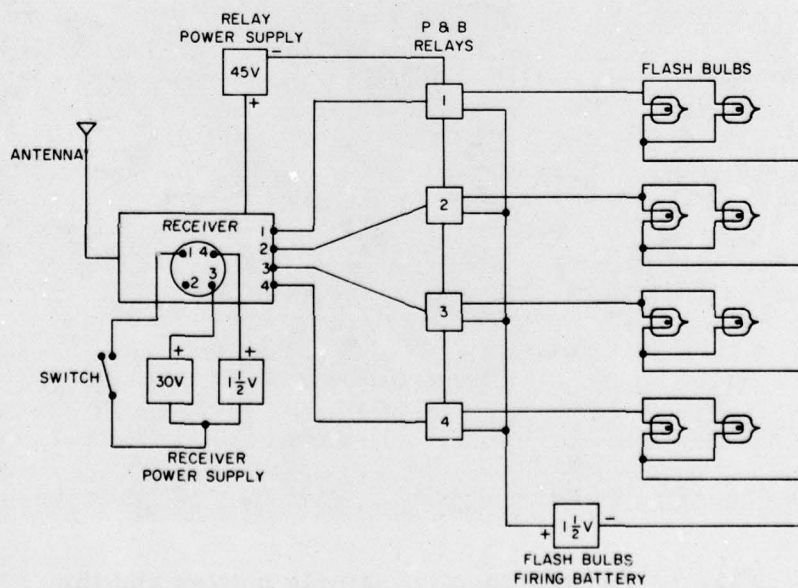

Fig. 4 - Electronics of the remotely controlled intake mechanism

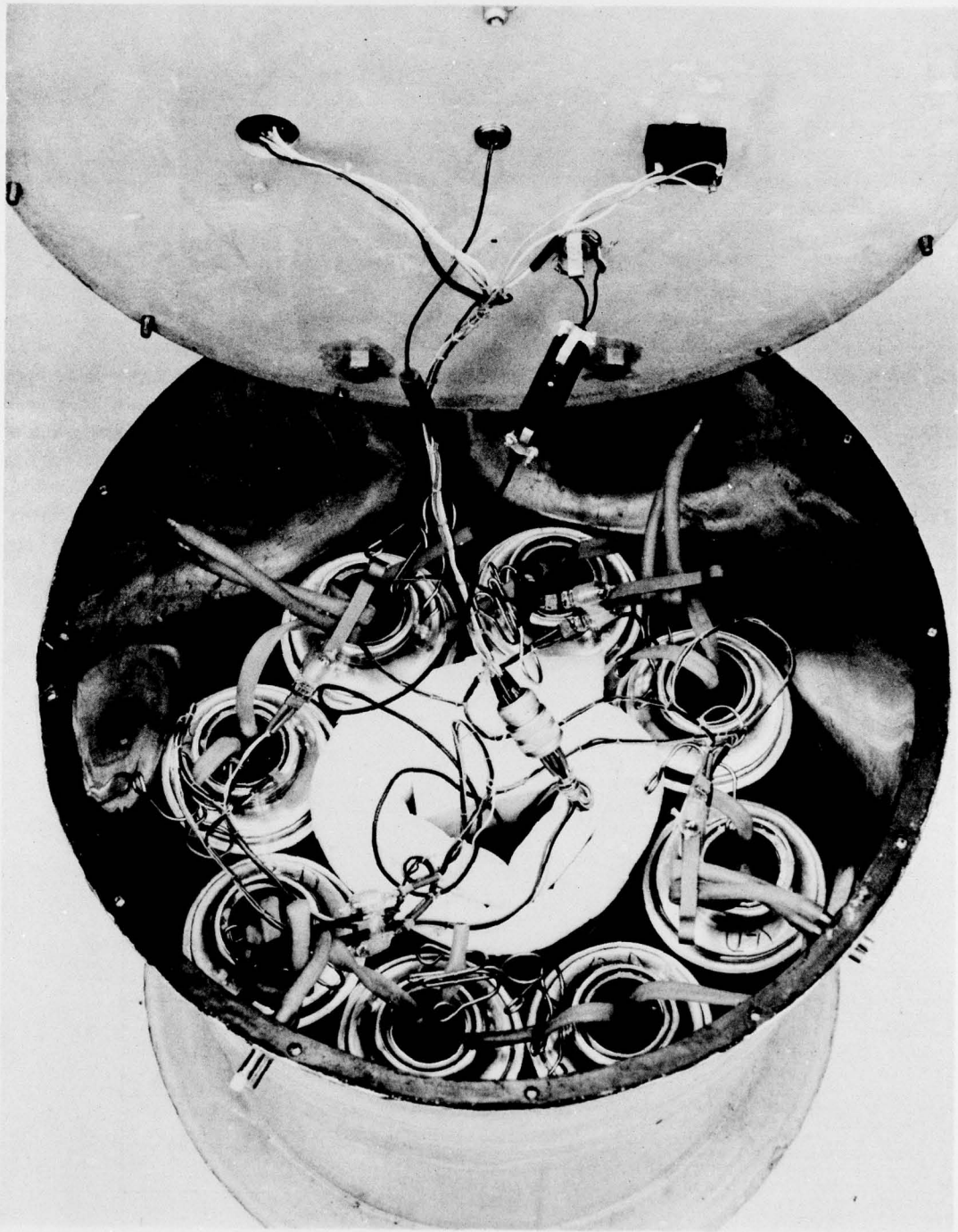

Fig. 5 - Arrangement of sample bottles and the triggering mechanism

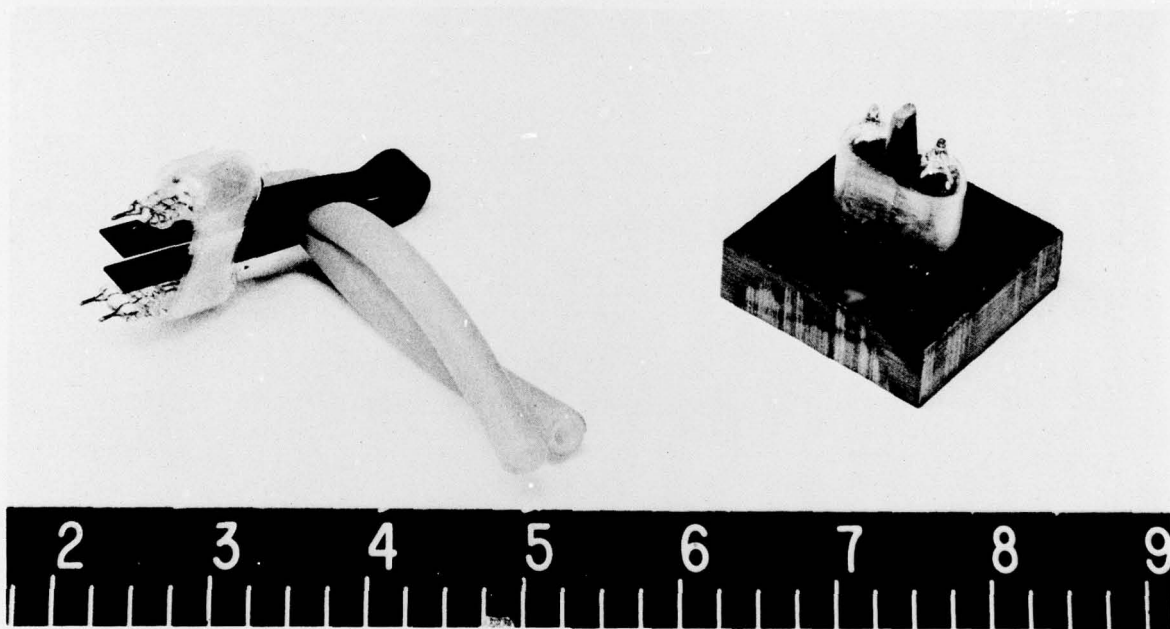

Fig. 6 - A cocked trigger (left) and the jig setup for wrapping the polyethylene strip (right)

COLUMBIA UNIVERSITY
HEALTH LABORATORIES
CONTRACT Nonr-266(84)