

AD-A074 142

DEFENCE RESEARCH ESTABLISHMENT OTTAWA (ONTARIO)
AN APPARATUS FOR THE MEASUREMENT OF THE WATER-VAPOUR PERMEABILITY--ETC(U)
JUN 79 B FARNWORTH
DREO-TN-79-1

F/6 11/5

UNCLASSIFIED

NL

| OF |
ADA
074142

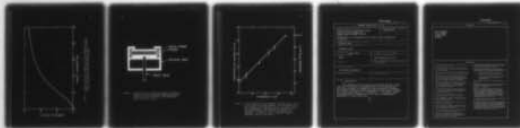

END
DATE
FILMED
10-79
DDC

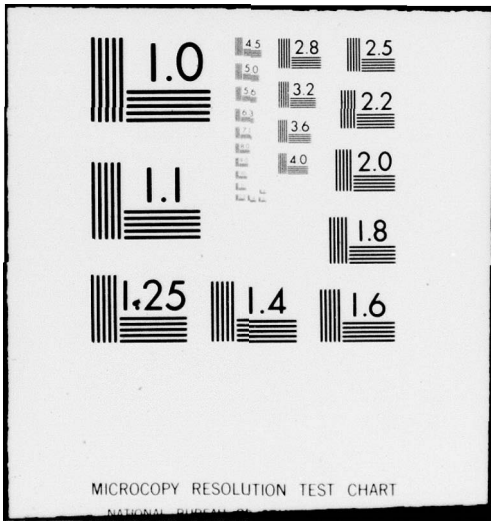

MICROCOPY RESOLUTION TEST CHART

NATIONAL BUREAU OF STANDARDS-1963-A

ADA 074142

RESEARCH AND DEVELOPMENT BRANCH
DEPARTMENT OF NATIONAL DEFENCE
CANADA

LEVEL IV

**DEFENCE RESEARCH
ESTABLISHMENT OTTAWA**

DREO TECHNICAL NOTE NO. 79-1
DREO TN 79-1

**AN APPARATUS FOR THE MEASUREMENT
WATER-VAPOUR PERMEABILITY OF TEXT**

by

B. Farnworth

FILE COPY



This document is
not to be released

CAUTION

This information is furnished with the express understanding
that proprietary and patent rights will be protected.

RESEARCH AND DEVELOPMENT BRANCH

DEPARTMENT OF NATIONAL DEFENCE
CANADA

12) 17 p.

DEFENCE RESEARCH ESTABLISHMENT OTTAWA

9) TECHNICAL NOTE NO. 79-1

6) AN APPARATUS FOR THE MEASUREMENT OF THE
WATER-VAPOUR PERMEABILITY OF TEXTILES

by
10) B. Farnworth
Environmental Protection Section
Protective Sciences Division

10) Brian / Farnworth

14) DREO-TN-79-1

PROJECT NO.
14800

11) JUN 1979
OTTAWA

404 576

slt

ABSTRACT

An apparatus has been constructed to measure the water-vapour resistance of textiles, in particular those such as battings and piles that are highly air permeable and have low vapour resistances. The technique has been tested by measuring the water vapour resistance of air gaps in the range 1 to 8 mm thickness. No systematic errors were observed with a random error in the resistance measurement equivalent to 0.5 mm of still air.

RÉSUMÉ

On a mis au point un appareil pour mesurer la résistance des textiles à la vapeur d'eau, et particulièrement de ceux, comme les tissus peluchés et d'autres à formation en nappes, qui sont très perméables à l'air et offrent une faible résistance à la vapeur. La méthode a été éprouvée par la mesure de la résistance à la vapeur d'eau, d'espaces d'air, d'une épaisseur de 1 à 8 mm. On n'a pas relevé d'erreurs systématiques, et ce pour une erreur aléatoire dans la mesure de la résistance, équivalente à 0.5 mm d'air immobile.

Accession For	
NTIS GRA&I	
DDC TAB	
Unannounced	
Justification	
By	
Distribution/	
Availability Codes	
Dist	Avail and/or special
A	

INTRODUCTION

Since the accumulation of water in clothing as a result of sweating seriously degrades its thermal insulation, a knowledge of the propagation of water is essential to the design of good clothing. In order to predict the water vapour transport properties of the clothing system as a whole, a knowledge of the water vapour resistance of each constituent material is required. This paper describes an apparatus designed to measure the water vapour resistance of all types of materials, including insulating fabrics such as piles and battings, that are used in arctic clothing systems.

The propagation of water vapour through a dry fabric is governed by an equation of the form:

$$(1) \quad M = A\Delta P/R$$

where M is the mass transmitted per unit time

A is the area of the fabric

ΔP is the difference in partial pressure of water vapour across the fabric

and R is the vapour resistance of a unit area of the fabric.

Standard methods for the determination of R consist basically of placing the sample over a dish of pure water, at a fixed distance from the water surface, in a controlled temperature and humidity environment, and measuring the weight loss of the dish (1)(2). Such a test measures not only the resistance to the passage of water vapour of the sample but also that of the air gap between the water and the sample and that from the upper surface of the sample to the surrounding atmosphere. These extraneous resistances can be eliminated or estimated by a variety of techniques. For example, the effect of the air gap can be estimated by varying its thickness and noting the change in overall resistance (3) or the resistance between the sample and the atmosphere can be minimized by generating an air flow over the sample (1). However, neither of these methods is applicable to materials such as battings where the surface is not sufficiently well defined to permit accurate adjustment of an air gap and where the high air permeability of the material precludes generating an air flow.

These difficulties have been overcome by the apparatus described in this paper. In this apparatus, the sample is sandwiched between two layers of a microporous Teflon sheet which is highly permeable to water vapour (4). Thus, on one side, the liquid water can be brought into contact with the Teflon, eliminating the air gap and, on the other, dry air can be blown over the Teflon, minimizing the sample-to-atmosphere resistance. The resistance of the two layers of Teflon is taken into account by measuring the overall resistance of the apparatus with and without the sample in place.

EQUIPMENT AND PROCEDURES

Description of the Apparatus

The apparatus is shown schematically in Figure 1 with the details of the sample holder in Figure 2. The upper portion of the sample holder contains distilled water separated from the sample by a sheet of microporous Teflon (4) supported by a stainless-steel mesh. The sample is sealed into a ring of silicone rubber (5) to prevent escape of water vapour at the edges. The sample is separated from the lower portion of the chamber by a second sheet of Teflon. Dry air is circulated, at a constant rate of about 4.8 l/min, through this chamber and drying tubes of CaSO_4 . The sample chamber sits on a scale, readable to 0.1 g and its mass is noted every 5 or 10 minutes to obtain the mass loss rate. The vapour pressure above the sample is taken as the saturation vapour pressure of water at the temperature of the water bath, measured with a copper-constantan thermocouple to an accuracy of 0.2°C . The vapour pressure of the returning dry air is assumed to be that given by the manufacturer of the drying tubes (6) (dew point $\sim -80^\circ\text{C}$) which is negligible.

The resistance for the passage of water vapour from the bath to the drying tubes is then given by equation 1 with ΔP equal to the saturation vapour pressure at the water bath temperature. The mass loss rate is measured over a period of several hours, after an initial stabilization period of sufficient duration to establish a constant loss rate (about one-half hour for a non-hygroscopic material).

The resistance of the sample is taken as the difference in overall resistance with and without the sample in place, times a small correction factor;

$$(2) \quad R_{\text{sample}} = (R_{\text{with sample}} - R_{\text{without sample}}) \times C$$

The correction factor C arises because the area of the sample is about 15% larger than the area of the water surface. Hence the flow of water vapour is not strictly perpendicular to the water surface and the rate is slightly larger than that expected from equation 1. C has been calculated from a numerical solution of Laplace's equation, which governs the vapour flow, in the actual experimental geometry (7). The results are shown in Figure 3, as a function of sample thickness, for a constant sample area equal to 1.15 times the water surface area.

Sample Preparation

The samples are sealed into a ring of silicone rubber by means of a rotational mold shown in cross section in Figure 4. The sample is held between two aluminum plates separated by the nominal thickness of the sample. The mold is spun at 1800 rpm and a mixture of room temperature vulcanizing rubber and hardener (5) is fed onto the top plate. The rubber flows to the outside rim of the mold forming a ring which seals the edges of the sample. The height of the ring is the thickness of the sample plus 12 mm above and below. The sample holder has a 12-mm shoulder on the side of each of the upper and lower chambers (see Figure 2) so that when the sample is placed in the holder the two layers of Teflon are held at a spacing equal to the nominal thickness of the sample. In this way the compression of the sample is maintained at a known value during the measurement.

RESULTS AND DISCUSSION

The performance of the apparatus was tested by measuring the vapour diffusion resistance of air gaps of thickness in the range 1 to 8 mm. The results are shown in Figure 5 where the overall resistance of the apparatus is plotted versus the gap thickness. To correct for the area discrepancy mentioned above the thickness has been divided by the correction factor C . The resistance is expressed as the thickness of a layer of still air expected to have that resistance. This latter quantity is calculated from handbook (8) values of the diffusion constant for water vapour into air.

The graph is expected to be a straight line of unit slope, the zero thickness intercept giving the residual resistance of the apparatus without a sample. The line drawn in Figure 5 is the best-fit straight line of unit slope and agrees with the data within the random experimental error.

The error arises primarily from the inaccuracy in the weight measurements which are sensitive to fluctuations in room temperature and to air currents. The measurements improve with the length of time over which they are taken. These data are an average of three trials at each point taken over about 3 h per trial. The error bars indicate statistical standard error among the three trials.

The resistance values measured for a few fabrics of current interest to the clothing research program are listed in Table I.

CONCLUSION

It is concluded from the results shown in Figure 5 that the apparatus is accurate to a resistance of about 0.5 mm equivalent air gap without systematic error.

TABLE I

Water-Vapour Resistance of Some Textile Materials

Sample	Thickness (mm)	R ($\text{m}^2 \text{ s pa kg}^{-1}$)	R (mm equivalent still air)
Thinsulate ^a M 400	7.7	$(6.3 \pm .3) \times 10^7$	$11.5 \pm .5$
Thinsulate ^b M 530	6.4	$(4.0 \pm .6) \times 10^7$	7.3 ± 1.0
Thinsulate ^c CS 150	3.2	$(2.6 \pm .2) \times 10^7$	$4.8 \pm .4$
Goretex* ^d	0.36	$(1.83 \pm .04) \times 10^7$	$4.10 \pm .07$
Text 7-6-5 ^e	0.38	$(0.42 \pm .02) \times 10^7$	$0.76 \pm .04$

* Laminated between Nylon-Tricot and Nylon-Poplin

- a. 3M Company, microfibre non-woven polypropylene batting, 400 g/m².
- b. As above, 530 g/m².
- c. 3M Company, microfibre non-woven polyester/polypropylene composite batting, 150 g/m².
- d. Gore Industries Ltd, microporous/Teflon Sheet.
- e. 50/50 Nylon/cotton twist fabric, 170 g/m², 0G107 dye.

REFERENCES

1. Canadian Government Specifications Board 4-GP-2, Method 49 (Control Dish Method).
2. Whelan E.M. et al. Textile Research Journal 25, 197 (1955).
3. Spencer-Smith J.L., Clothing Research Journal 5, 82 (1977).
4. Gore-Tex. Gohlke, D.J. and Tanner, J.C. J. Coated Fabrics 6 28 (1976).
5. RTV-511, General Electric Corp. (USA).
6. Indicating Drierite, W.A. Hammond Drierite Co. (USA).
7. The solution technique is similar to that in:
Pitts, D.R. and Sissom, L.E. "Theory and Problems in Heat Transfer", McGraw-Hill (1977).
8. American Institute of Physics Handbook. McGraw-Hill (1957).

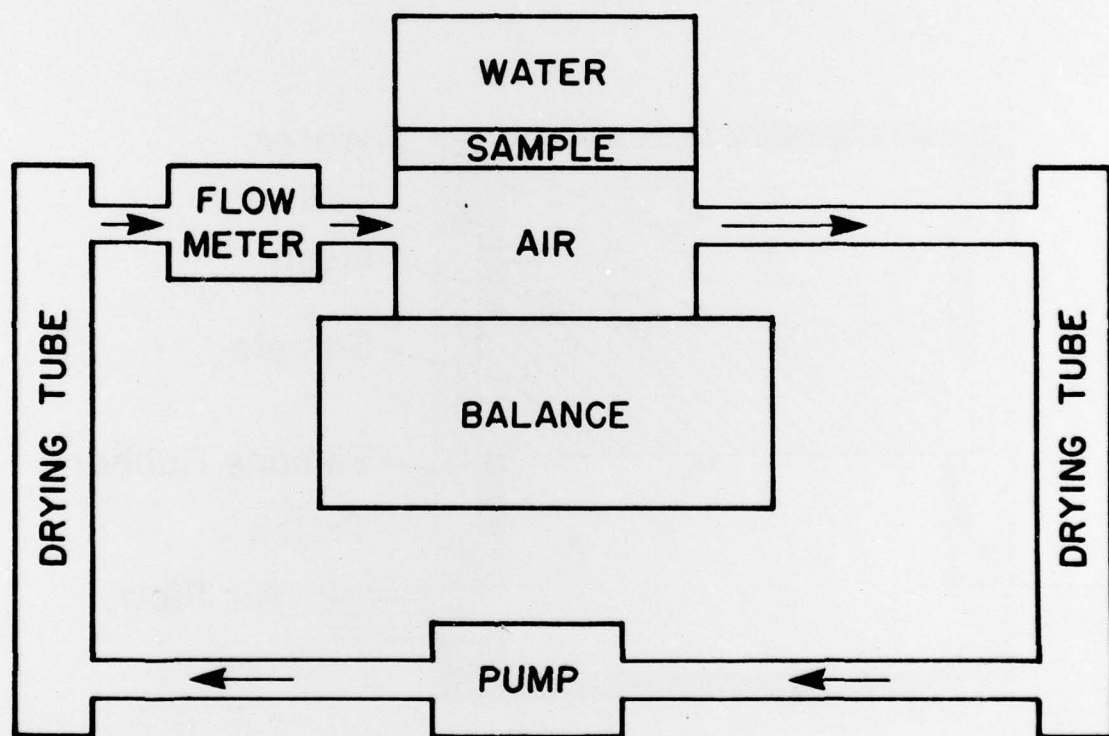

Figure 1. Schematic diagram of the apparatus. The sample is held between two layers of microporous Teflon with water on one side and dry air on the other. The mass of the sample holder is monitored to give the water vapour diffusion rate.

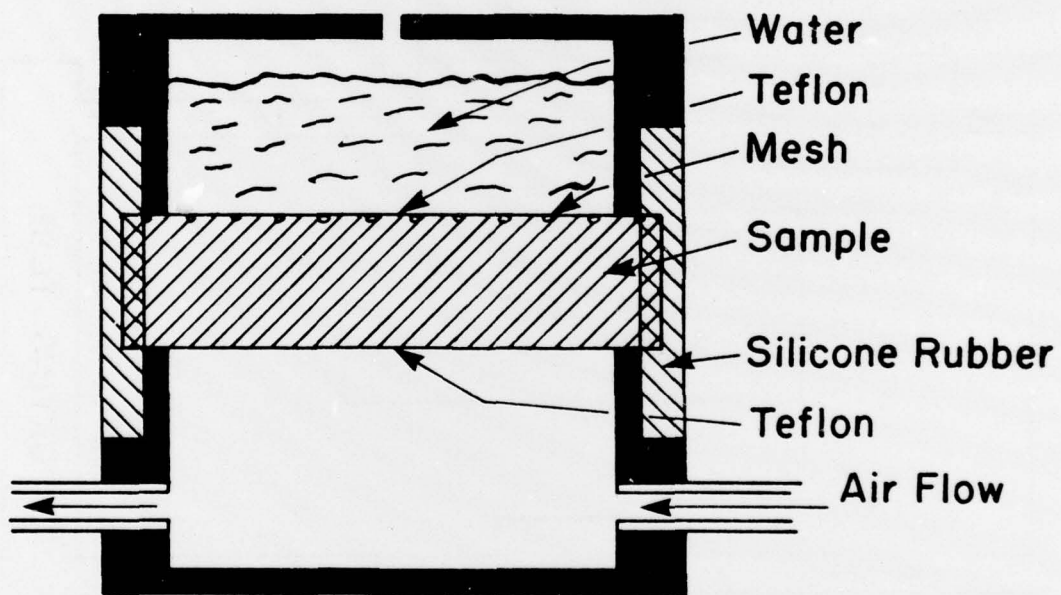

Figure 2. Details of the sample holder. The sample is embedded in a ring of silicone rubber to prevent leakage of water vapour at the edges. The upper layer of Teflon is supported by a stainless-steel mesh.

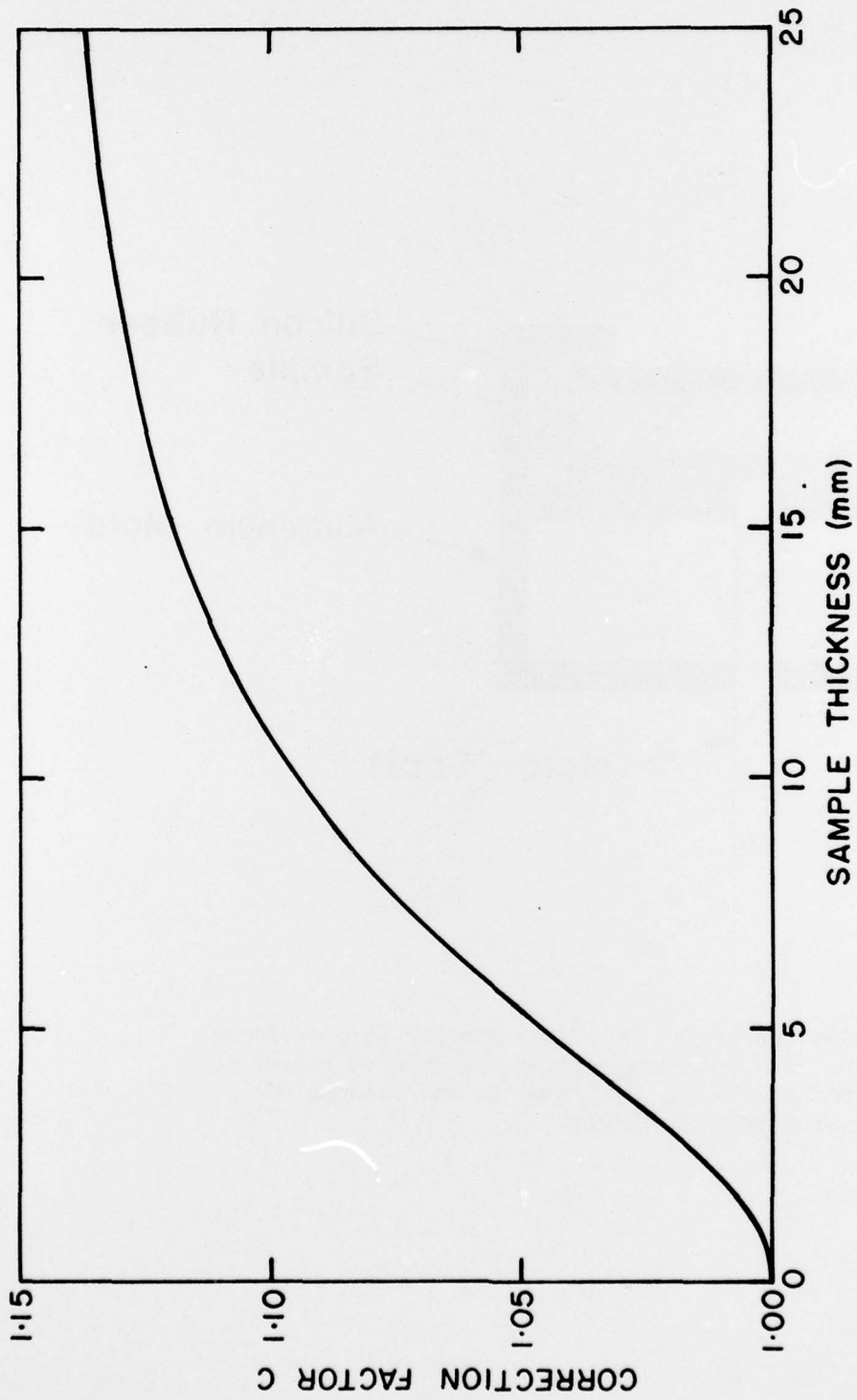

Figure 3. Correction factor to compensate for the difference in area between the sample and the water surface. The calculation is for a fixed sample area and varied thickness.

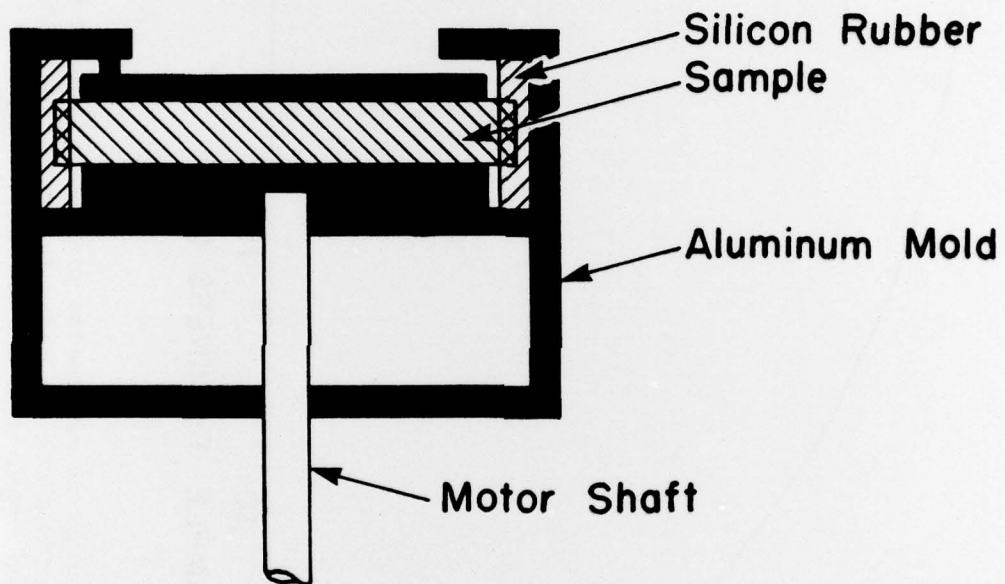

Figure 4. Rotational mold for imbedding samples into silicone rubber. The room-temperature vulcanizing rubber is injected at the top and flows to the outside rim where it sets into a ring.

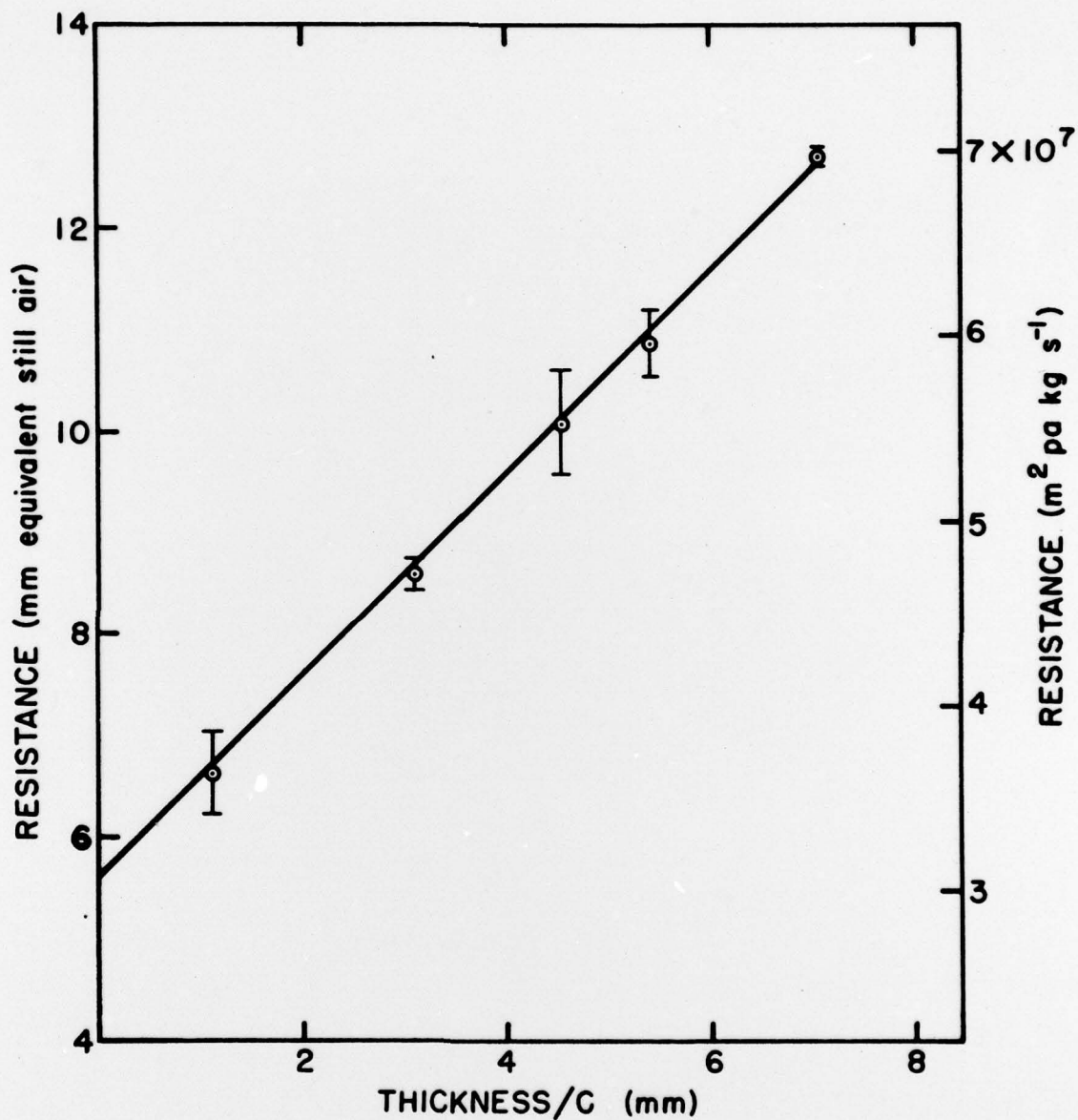

Figure 5. Overall resistance of the apparatus with the sample replaced by air layers of various thickness. The thicknesses have been divided by the correction factor C to account for the area discrepancies. The resistance is expressed as the thickness of a perfectly still air layer having that resistance. The line is of unit slope with intercept adjusted to fit the data points.

UNCLASSIFIED

Security Classification

DOCUMENT CONTROL DATA - R & D		
(Security classification of title, body of abstract and indexing annotation must be entered when the overall document is classified)		
1. ORIGINATING ACTIVITY Defence Research Establishment Ottawa National Defence Headquarters Ottawa, Ontario, Canada K1A 0Z4	2a. DOCUMENT SECURITY CLASSIFICATION Unclassified	2b. GROUP
3. DOCUMENT TITLE An Apparatus for the Measurement of the Water Vapour Permeability of Textiles		
4. DESCRIPTIVE NOTES (Type of report and inclusive dates) Technical Note.		
5. AUTHOR(S) (Last name, first name, middle initial) Farnworth, Brian		
6. DOCUMENT DATE March 1979	7a. TOTAL NO OF PAGES 11	7b. NO OF REFS 8
8a. PROJECT OR GRANT NO. 14B00	9a. ORIGINATOR'S DOCUMENT NUMBER(S) DREO Technical Note 79-1	
8b. CONTRACT NO.	9b. OTHER DOCUMENT NO.(S) (Any other numbers that may be assigned this document)	
10. DISTRIBUTION STATEMENT Distribution unlimited.		
11. SUPPLEMENTARY NOTES	12. SPONSORING ACTIVITY	
13. ABSTRACT Unclassified An apparatus has been constructed to measure the water vapour resistance of textiles, in particular those such as battings and piles that are highly air permeable and have low vapour resistances. The technique has been tested by measuring the water vapour resistance of air gaps in the range 1 to 8 mm thickness. No systematic errors were observed with a random error in the resistance measurement equivalent to 0.5 mm of still air.		

UNCLASSIFIED

Security Classification

KEY WORDS

Test equipment
Water vapour
Permeability
Fabrics

INSTRUCTIONS

1. **ORIGINATING ACTIVITY:** Enter the name and address of the organization issuing the document.
- 2a. **DOCUMENT SECURITY CLASSIFICATION:** Enter the overall security classification of the document including special warning terms whenever applicable.
- 2b. **GROUP:** Enter security reclassification group number. The three groups are defined in Appendix "M" of the DRB Security Regulations.
3. **DOCUMENT TITLE:** Enter the complete document title in all capital letters. Titles in all cases should be unclassified. If a sufficiently descriptive title cannot be selected without classification, show title classification with the usual one-capital-letter abbreviation in parentheses immediately following the title.
4. **DESCRIPTIVE NOTES:** Enter the category of document, e.g. technical report, technical note or technical letter. If appropriate, enter the type of document, e.g. interim, progress, summary, annual or final. Give the inclusive dates when a specific reporting period is covered.
5. **AUTHOR(S):** Enter the name(s) of author(s) as shown on or in the document. Enter last name, first name, middle initial. If military, show rank. The name of the principal author is an absolute minimum requirement.
6. **DOCUMENT DATE:** Enter the date (month, year) of Establishment approval for publication of the document.
- 7a. **TOTAL NUMBER OF PAGES:** The total page count should follow normal pagination procedures, i.e., enter the number of pages containing information.
- 7b. **NUMBER OF REFERENCES:** Enter the total number of references cited in the document.
- 8a. **PROJECT OR GRANT NUMBER:** If appropriate, enter the applicable research and development project or grant number under which the document was written.
- 8b. **CONTRACT NUMBER:** If appropriate, enter the applicable number under which the document was written.
- 9a. **ORIGINATOR'S DOCUMENT NUMBER(S):** Enter the official document number by which the document will be identified and controlled by the originating activity. This number must be unique to this document.
- 9b. **OTHER DOCUMENT NUMBER(S):** If the document has been assigned any other document numbers (either by the originator or by the sponsor), also enter this number(s).
10. **DISTRIBUTION STATEMENT:** Enter any limitations on further dissemination of the document, other than those imposed by security classification, using standard statements such as:
 - (1) "Qualified requesters may obtain copies of this document from their defence documentation center."
 - (2) "Announcement and dissemination of this document is not authorized without prior approval from originating activity."
11. **SUPPLEMENTARY NOTES:** Use for additional explanatory notes.
12. **SPONSORING ACTIVITY:** Enter the name of the departmental project office or laboratory sponsoring the research and development. Include address.
13. **ABSTRACT:** Enter an abstract giving a brief and factual summary of the document, even though it may also appear elsewhere in the body of the document itself. It is highly desirable that the abstract of classified documents be unclassified. Each paragraph of the abstract shall end with an indication of the security classification of the information in the paragraph (unless the document itself is unclassified) represented as (TS), (S), (C), (R), or (U).

The length of the abstract should be limited to 20 single-spaced standard typewritten lines; 7½ inches long.
14. **KEY WORDS:** Key words are technically meaningful terms or short phrases that characterize a document and could be helpful in cataloging the document. Key words should be selected so that no security classification is required. Identifiers, such as equipment model designation, trade name, military project code name, geographic location, may be used as key words but will be followed by an indication of technical context.

