

AD-A074 243

ARMY INFANTRY SCHOOL FORT BENNING GA

F/G 5/9

THE FUNDAMENTALS OF MAP READING: A SELF-INSTRUCTIONAL TEXT.(U)
JAN 70

UNCLASSIFIED

NL

1 OF 1
AD
A074243



END
DATE
FILMED
10-79
DDC

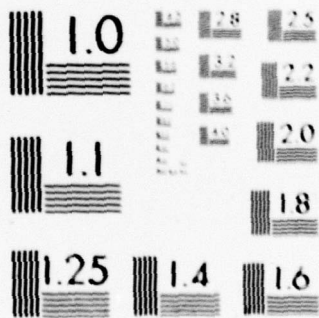

MICROCOPY RESOLUTION TEST CHART

ADA 074243

TIS -
Inst Mat

⑥ **THE
FUNDAMENTALS
OF
MAP READING: LEVEL II**
A Self-Instructional Text,

①

038 600

⑪ Jan 78

⑫ 72 p.



HumRRO
DIVISION NO. 4

MAR 26 1970

P. O. BOX 236
FT. BENNING, GEORGIA

DDC
RECEIVED
SEP 21 1979
B

DDC FILE COPY

DISTRIBUTION STATEMENT A
Approved for public release;
Distribution Unlimited

By Map Reading Committee
US Army Infantry School
FORT BENNING, GEORGIA

038 600 JANUARY 1970 79 09 24 412



DEPARTMENT OF THE ARMY
ARI FIELD UNIT, BENNING
U. S. ARMY RESEARCH INSTITUTE FOR THE BEHAVIORAL AND SOCIAL SCIENCES
P.O. BOX 2086, FORT BENNING, GEORGIA 31905

PERI-IJ

8 August 1979

SUBJECT: Shipment of Documents

Defense Documentation Center
Cameron Station
Alexandria, VA 22314
ATTN: Selection & Cataloging

The Documents in these shipments are approved for public release. The distribution is unlimited.

FOR THE CHIEF:

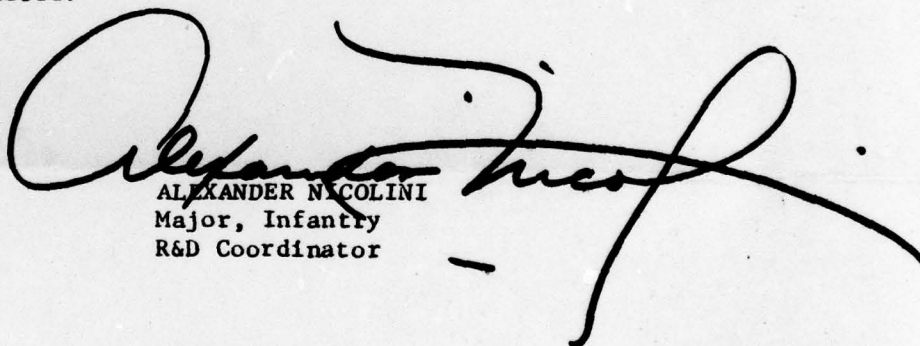

ALEXANDER NICOLINI
Major, Infantry
R&D Coordinator

-A

GENERAL INSTRUCTIONS

COURSE OBJECTIVE:

To enable you to read a map, applying those theories, principles and techniques considered to be essential for a small unit leader.

STUDENT PERFORMANCE OBJECTIVES:

As a result of working problems in this programmed text in the FUNDAMENTALS AND THEORY OF MAP READING, the student will be able to:

1. Locate and identify the marginal information on a map.
2. Identify those common topographic and military symbols which a small unit leader encounters in map reading.
3. Locate specific points on a map quickly and accurately and express ground distance between points accurately by applying the map scale.
4. Read, plot and convert grid azimuths to magnetic azimuths and magnetic azimuths to grid azimuths.
5. Locate your own unknown position, or locate a distant or inaccessible point by applying polar coordinates, intersection, resection or modified resection as appropriate.

INTRODUCTION:

This course is presented to review ~~with you~~ the fundamentals and theory of map reading. We realize that for many of you this instruction will be merely a review of the basic skills which you have previously learned.

Map reading is a basic military subject but an important one, and it will increase in importance to you as you progress throughout your career. It is important to you as a commander, as a student, as an instructor, and as a staff officer. Map reading is important to you because much of the instruction you will receive will be based upon the assumption that you know how to read a map. In a troop unit, it will be you who will be teaching map reading to your troops. Your success in teaching will depend upon how well you have grasped the subject. To the commander and staff officer, proficiency in map reading is vital. In most cases, it is a map that the commander uses to study the area over which he is to operate. The staff officer bases his operational planning on the use of a map. Many times these plans will be transformed into orders and come to you, the small unit leader, in the form of map overlays. Other times, you will receive written orders; but in order to carry them out, you will need to use a map. You can see that it will be very difficult for you to interpret and execute your orders unless you possess the ability to read a map quickly and accurately.

79 09 24 412

INSTRUCTIONS

As you go through this programmed text, you will observe that information is systematically arranged into small simple learning steps. These are boxed into frames. Because the purpose is to TEACH, rather than merely present information or merely to test information, a single point may be repeated several times in different forms or contexts. What may seem to you needless repetition in other kinds of reading material is done here deliberately to reinforce learning.

Each frame requires you to do something: read, remember, solve a problem, select an alternate or fill in a word or phrase. Immediately thereafter, in the next box, the answer and explanation is given. However, don't look ahead at the answer before you study the statement or problem.

THE 5 X 8 CARD PROVIDED IS TO BE USED AS A MASK TO CONCEAL THE ANSWER AND THE NEXT FRAME. PLACE IT ON THE DOTTED LINE SO THAT FRAME 1 IS EXPOSED. READ THE FRAME AND ANSWER IT. THEN SLIDE THE CARD DOWN TO THE SOLID LINE SO THAT YOU CAN READ THE CORRECT ANSWER AND COMPARE. PROCEED TO FRAME 2 BY SLIDING THE CARD DOWN TO THE NEXT DOTTED LINE. CONTINUE, IN THIS WAY, THROUGHOUT THE TEXT.

Occasionally, if you get the correct solution, you may be directed to skip the next few frames. This is to save you time, and reward you if you know this subject area. Such skipping is always optional.

ACCESSION for		
NTIS	White Section	<input checked="" type="checkbox"/>
DDC	Buff Section	<input type="checkbox"/>
UNANNOUNCED		<input type="checkbox"/>
JUSTIFICATION _____		
BY _____		
DISTRIBUTION/AVAILABILITY CODES		
Dist. AVAIL. and/or SPECIAL		
A		

TEAR ALONG PERFORATED LINE

INSTRUCTIONS

1. TAKE THIS 5 X 8 CARD AND PLACE IT ALONG THE FIRST DOTTED LINE. THIS WILL EXPOSE FRAME #1. READ THE FRAME AND ANSWER IT.
2. THEN SLIDE THE CARD DOWN TO THE SOLID LINE. NOW YOU CAN READ THE CORRECT RESPONSE AND COMPARE YOUR ANSWER.
3. PROCEED TO THE NEXT FRAME BY SLIDING THE CARD TO THE NEXT DOTTED LINE.

TEAR ALONG PERFORATED LINE

MARGINAL INFORMATION

A map is defined as a line drawing to scale of a portion of the earth's surface as seen from above.

One of the first things you must do in reading a map is to locate and identify the basic Marginal Information. Realize, of course, that you will apply this information in greater detail as the course progresses. (See Illustration #1 and use with the following explanation.)

① SHEET NAME

The Sheet Name is located at the center of the top margin. Generally a map is named after its outstanding cultural or geographical feature.

② SHEET NUMBER

The Sheet Number is located in the upper right margin.

③ INDEX TO ADJOINING SHEETS

The Index to Adjoining Sheets appears in the extreme right of the lower margin.

④ DECLINATION DIAGRAM

Also located in the lower right hand corner is the Declination Diagram. All you need to remember at this time is that it indicates the direction and relationship of true, magnetic, and grid north.

⑤ SCALES

The map scale and the graphic (bar) scales are located in the center of the lower margin on the map. The Map Scale Note, expressed as a representative fraction (RF), gives the ratio of map distance to ground distance. The Graphic (bar) Scales are rulers used for the determination of ground distance.

⑥ CONTOUR INTERVAL NOTE

The Contour Interval Note appears in the center of the lower margin. The contour interval is the vertical distance between contour lines on the map.

⑦ GRID REFERENCE BOX

The Grid Reference Box is usually located in the center of the lower margin. It contains information for identifying grid zone and the 100,000 meter square in which the area represented by the map is located. It also provides instructions for giving grid references on the map.

(CONTINUED ON NEXT PAGE)

⑧ **CREDIT NOTE**

The Credit Note appears in the lower left of the bottom margin. This information tells you, the supervising agency, the date the map was compiled and when it was field checked.

⑨ **LEGEND**

The legend appears in the lower left margin of the map. It's a small portion of the map maker's dictionary, his shorthand method of identifying mapped features. He uses symbols to identify these features. These symbols are called **TOPOGRAPHIC SYMBOLS**.

To increase their value and ease of identification, **TOPOGRAPHIC SYMBOLS** have distinctive colors. The following map colors are standard:

1. **BLACK**..... man-made features; i. e., road, mine, quarry, building.
2. **RED** classification of man-made features such as roads and built-up areas.
3. **BLUE**..... drainage; i. e., stream, river, lake, swamp.
4. **GREEN**..... vegetation; i. e., orchard, grassland, woods.
5. **BROWN** elevation and relief; i. e., contour lines, hachures.

SECTION I GRID REFERENCE SYSTEM

1

We have been discussing the map maker's shorthand method of identifying mapped features. With this understanding we now have a need to correctly locate these features on the map.

The Military Grid Reference System provides a method which enables us to locate specific points on a map quickly and accurately. The Military Grid Reference System is superimposed on the Universal Transverse Mercator Grid System, which we will refer to hence forth as the UTM grid system. To better understand the Military Grid Reference System, we should have a basic knowledge of the UTM Grid System.

2

LOOK AT ILLUSTRATION 2A. You see that the Universal Transverse Mercator Grid System divides the surface of the earth between 84° North Latitude and 80° South Latitude into 60 grid zones.

These grid zones are numbered from 1 through 60. The example shown in the illustration 2A is grid zone number 3.

3

LOOK AT ILLUSTRATION 3A. You will see that each numbered grid zone is further divided into segments. Each grid zone segment is assigned a letter of the alphabet for identification. The letters I and O are omitted so they are not mistaken as numbers. Letters A, B, Y and Z are used for the polar regions. A grid zone designation identified as 3N means it is grid zone 3, and is the first segment north of the equator (see illustration 3A again).

1
Identifying
ectly

bles us
y Grid
ator
em. To
a

2
verse
rth

shown

3
rid
igned a
ed so
r the
id zone
in).

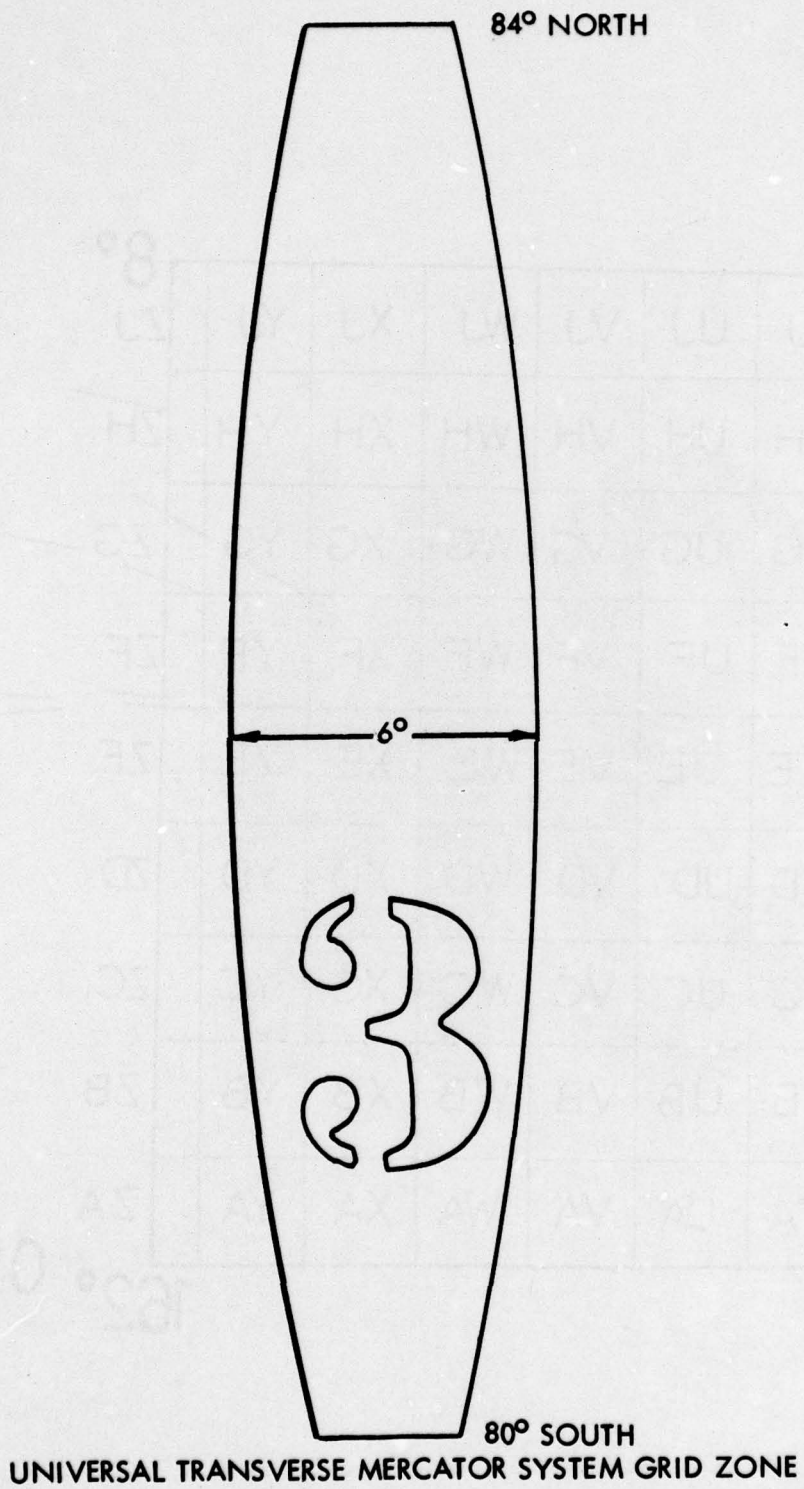

GRID
ZONE
SEGME

ILLUSTRATION 2A

2

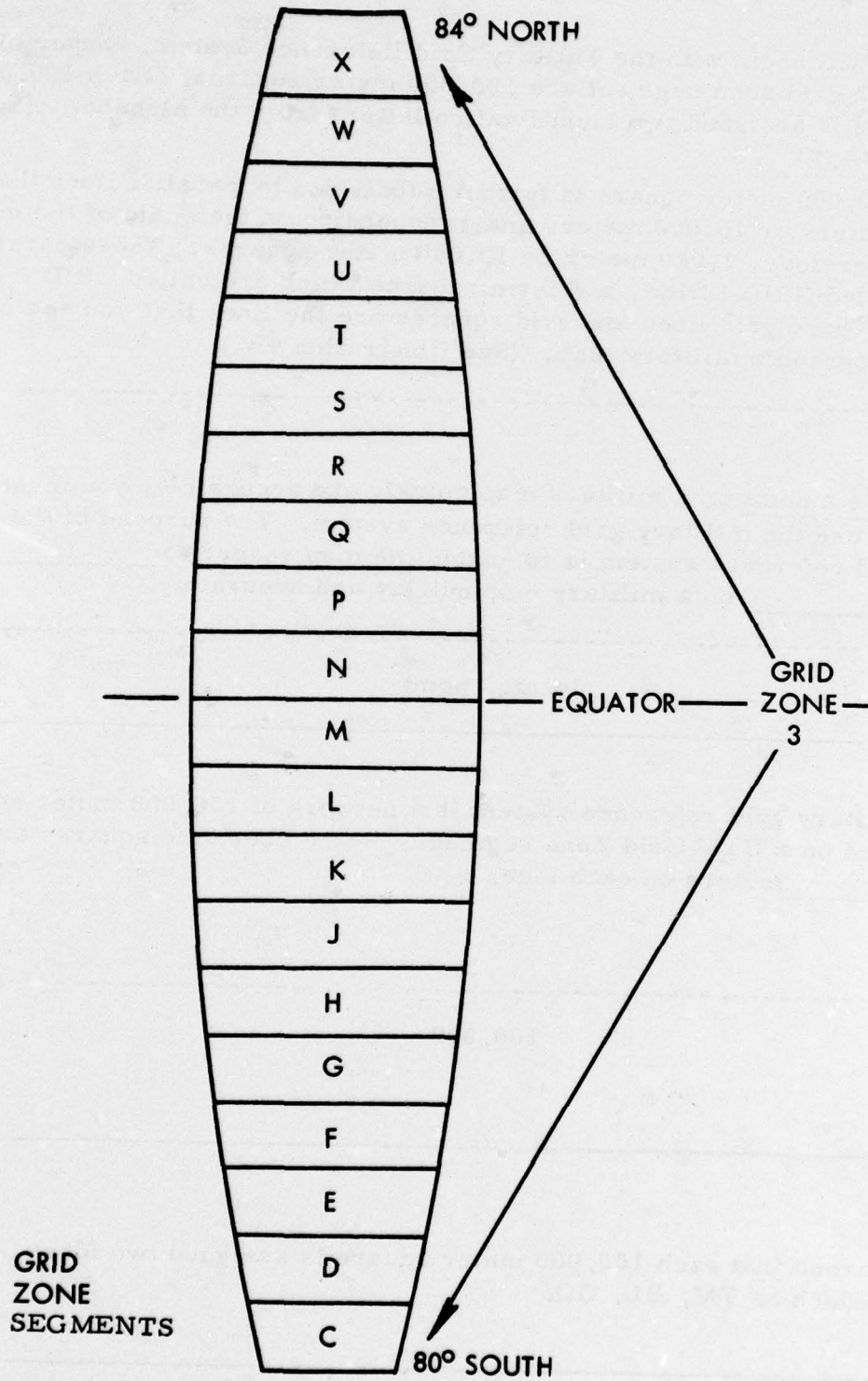

ILLUSTRATION 3A

4

Now we will begin with the Military Grid Reference System. Superimposed on each grid zone segment are 100,000 meter squares. Each 100,000 meter square is assigned two identification letters from the alphabet. (See illustration 4A.)

Each 100,000 meter square is further subdivided by parallel lines that are 1,000 meters or 10,000 meters apart (depending on the scale of the map), and form, therefore, 1,000 meter or 10,000 meter squares. These parallel lines are called GRID LINES, and form squares which are called GRID SQUARES. These grid lines and grid squares are the lines that you see on the standard topographic military map. (See illustration 4B.)

5

To locate a point on a military map quickly and accurately, you must know how to use the military grid reference system. The purpose of the military grid reference system is to enable the map reader to _____ a _____ on a military map quickly and accurately.

locate, point

6

The military grid reference system is a network of 100,000 meter squares superimposed on a UTM Grid Zone segment. Remember, the squares are _____ meters on each side.

100,000

7

You learned that each 100,000 meter square is assigned two identification letters such as EM, BL, GQ.

m-
,000
See
at
(map),
allel
on the

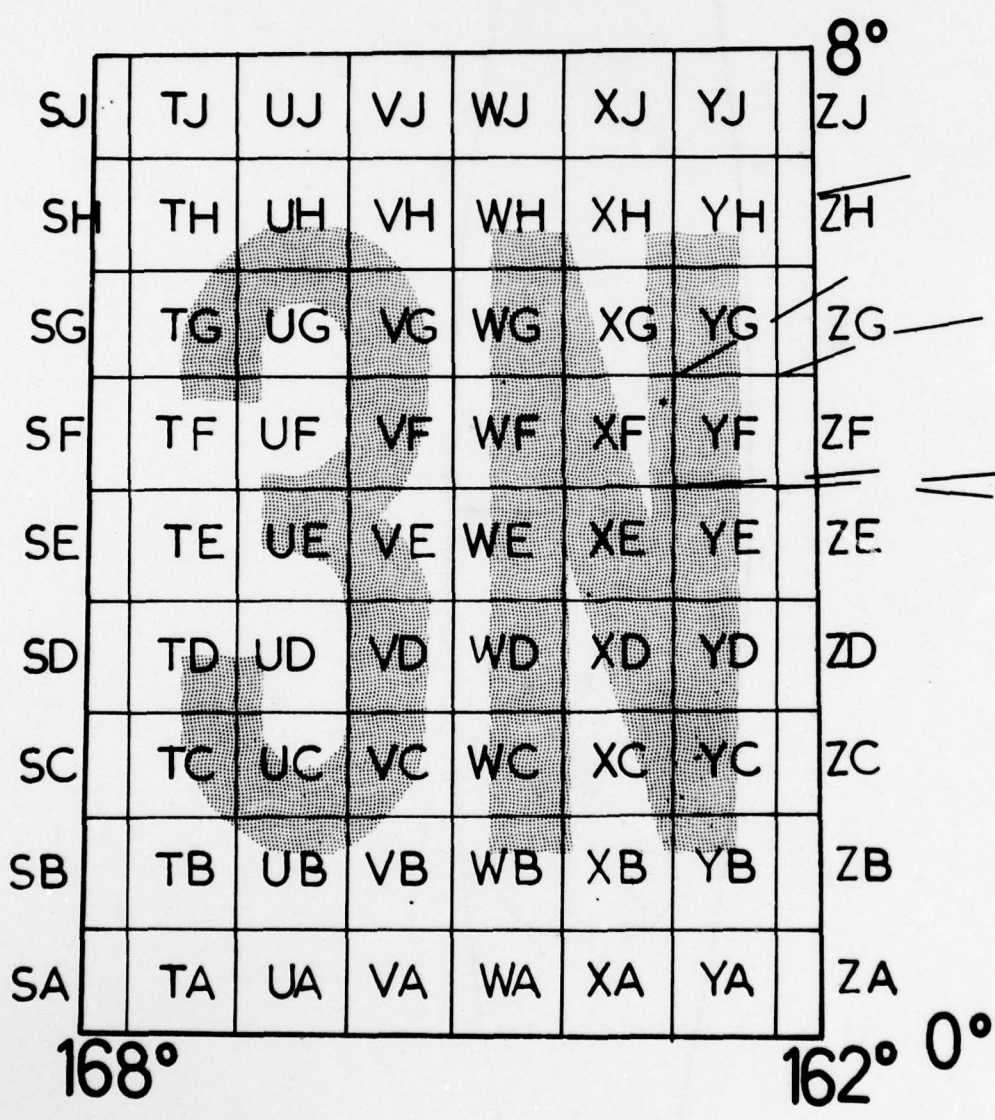

ILLUSTRATION 4A

2

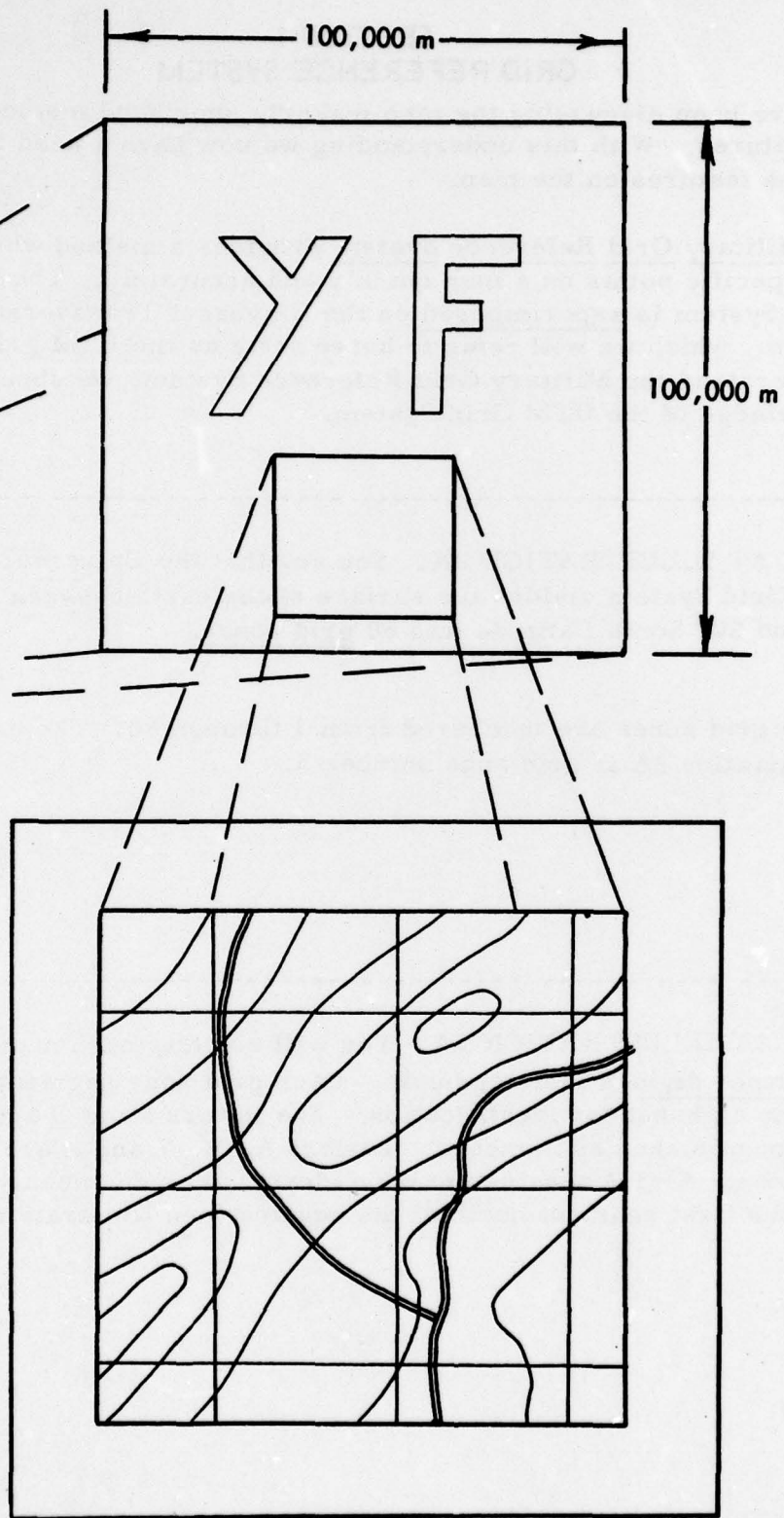

ILLUSTRATION 4B

14 3

COORDINATES

8

The 100,000 meter squares are further subdivided into 1,000 meter squares formed by North-South parallel lines and East-West parallel lines. This means that the distance between each grid line is 1,000 meters. The distance between grid lines represents _____ meters on the standard large scale map. (number)

1,000

9

Using Illustration 9A, note that the grid lines are identified by a set of digits. Disregard the smaller digits and USE ONLY the larger digits to identify a grid line. Note also, that each North-South grid line increases in value from west to east, and that each east-west grid line increases in value from south to north. This gives us one of our cardinal rules in map reading. Whenever you read a coordinate, you always read first RIGHT, then UP.

10

Suppose we wanted to locate spot elevation 450 to the nearest, 1,000 meters. (Use Illustration 9A) All we would have to do is to identify the grid square in which it is located. Remembering our cardinal rule of reading RIGHT and UP, we identify the last north-south grid line before arriving at spot elevation 450 as 11, and the last east-west grid line before arriving at spot elevation 450 as 43. The identity of the grid square is 1143. Note that where these two grid lines intersect in the lower left hand corner of the grid square identifies the grid square as 1143. We have, therefore, located a point to the nearest _____ meters by using a _____ digit coordinate.

1,000. 4

11

Suppose we want to locate spot elevation (SE) 450 to within 100 meters. Remember, our grid square is 1,000m square. All we have to do is to mentally divide grid square 1143 into tenths, or 100 meter segments. (See illustration 11A) By reading _____, we see that SE 450 is approximately six-tenths or 600 meters into the grid square, so our RIGHT reading is 116.

RIGHT

9

|

8

nes.
The
stand-

9

t of
es in
value
ading.

10

0
grid
ag
g at
at
that
grid
a
igit

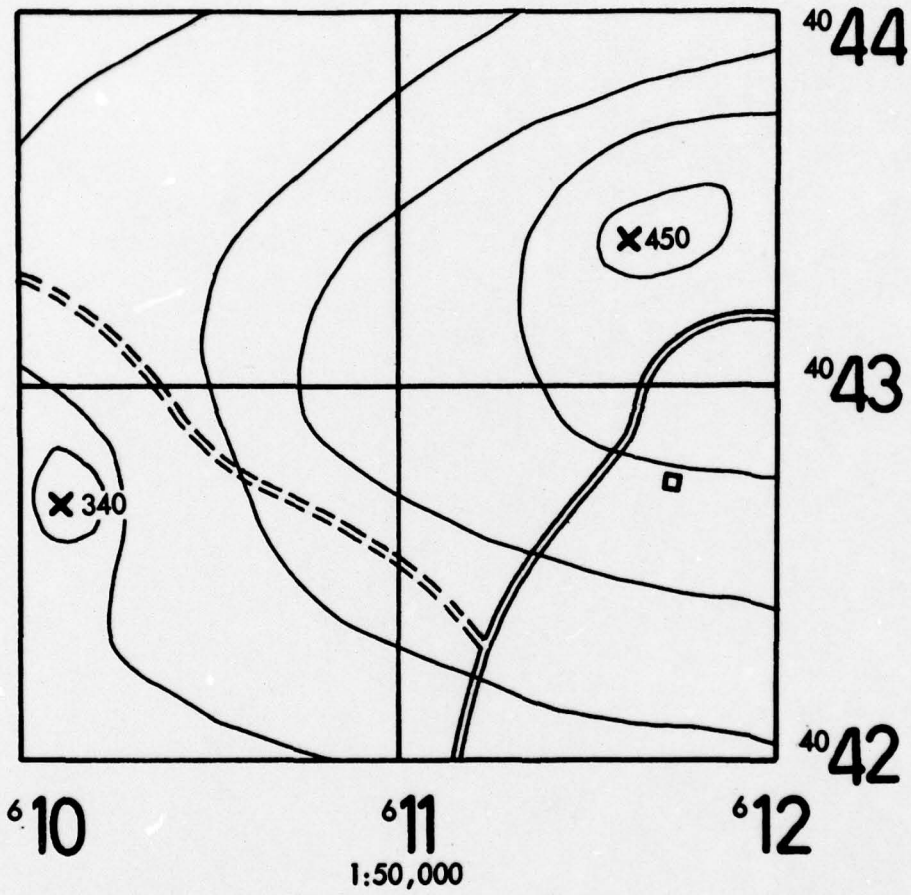

11

ers.

(See
ely
116.

ILLUSTRATION 9A

2

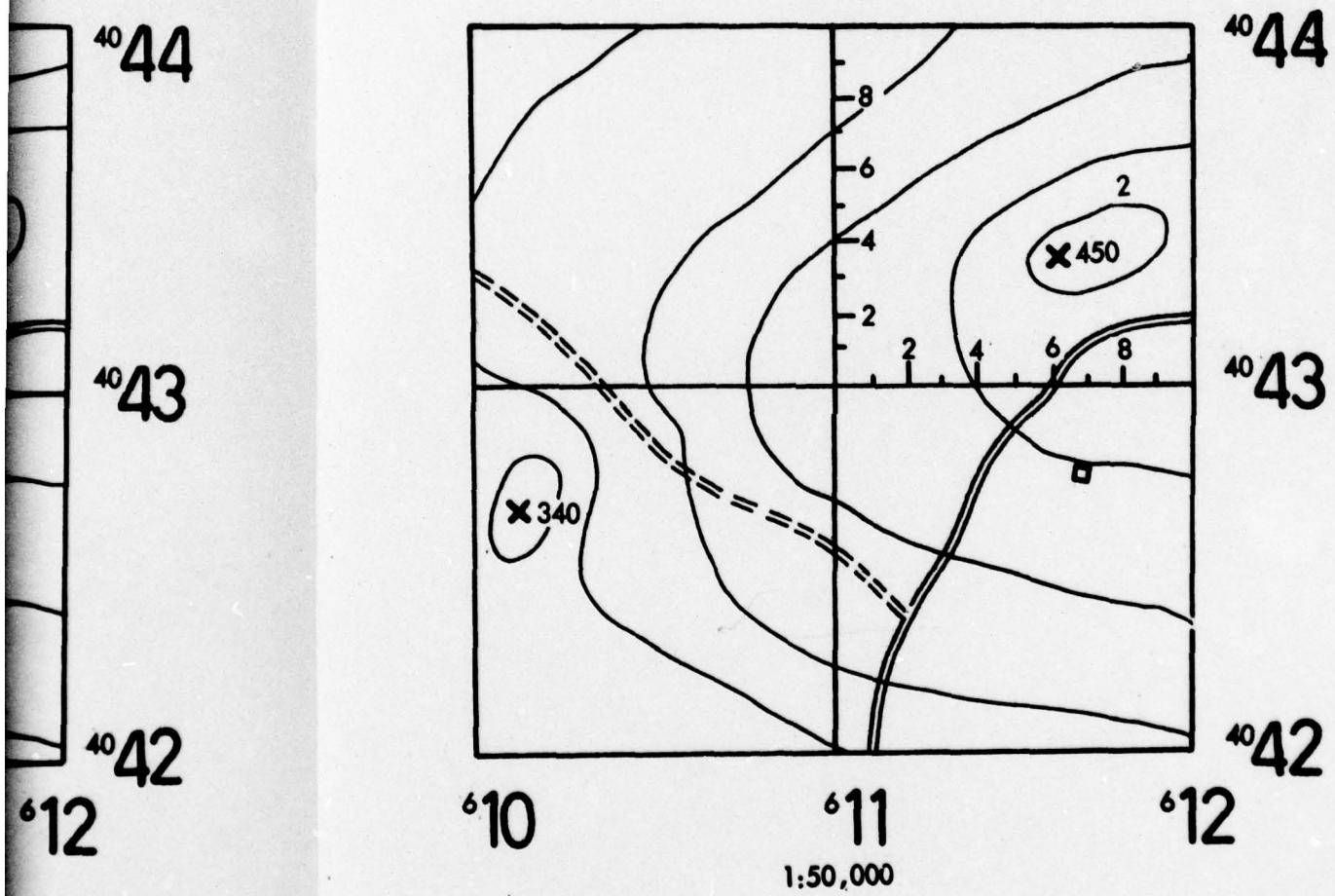

ILLUSTRATION 11A

12

By reading up, we see that SE 450 is approximately four-tenths of the way up into the grid square, so our UP reading is 434. We have now located SE 450 to the nearest _____ meters by using a _____ digit coordinate. The location of SE 450 is written as 116434.

100, 6

13

Use Illustration 13A. If we want to be more precise, that is, locate SE 450 to the nearest 10 meters, we must use the coordinate scale. First determine the scale of your map, then select the coordinate scale with the corresponding scale. Each side of the coordinate scale represents 1,000 meters. The long tick marks divide each side into 100 meter segments.

14

The following is the correct way to use a coordinate scale. Place the horizontal scale parallel to and directly on top of grid line 43 with the 0 mark at the lower left hand corner of grid square 1143. Keeping the horizontal scale on top of the 43 grid line, slide the scale over into the grid square until the vertical scale intersects the center of mass SE 450. Now reading from our 0 mark, our right reading shows that SE 450 lies exactly sixty three hundredths into the grid square or 630 meters. Our reading is, therefore, 1163.

15

Reading up we see that SE 450 lies exactly midway between three-tenths and four-tenths, or 350 meters up into the grid square. Our _____ reading is, therefore, 4335. We have located SE 450 to the nearest _____ meters by using an _____ digit coordinate. The location of SE 450 is written as 11634335.

UP, 10,
Eight

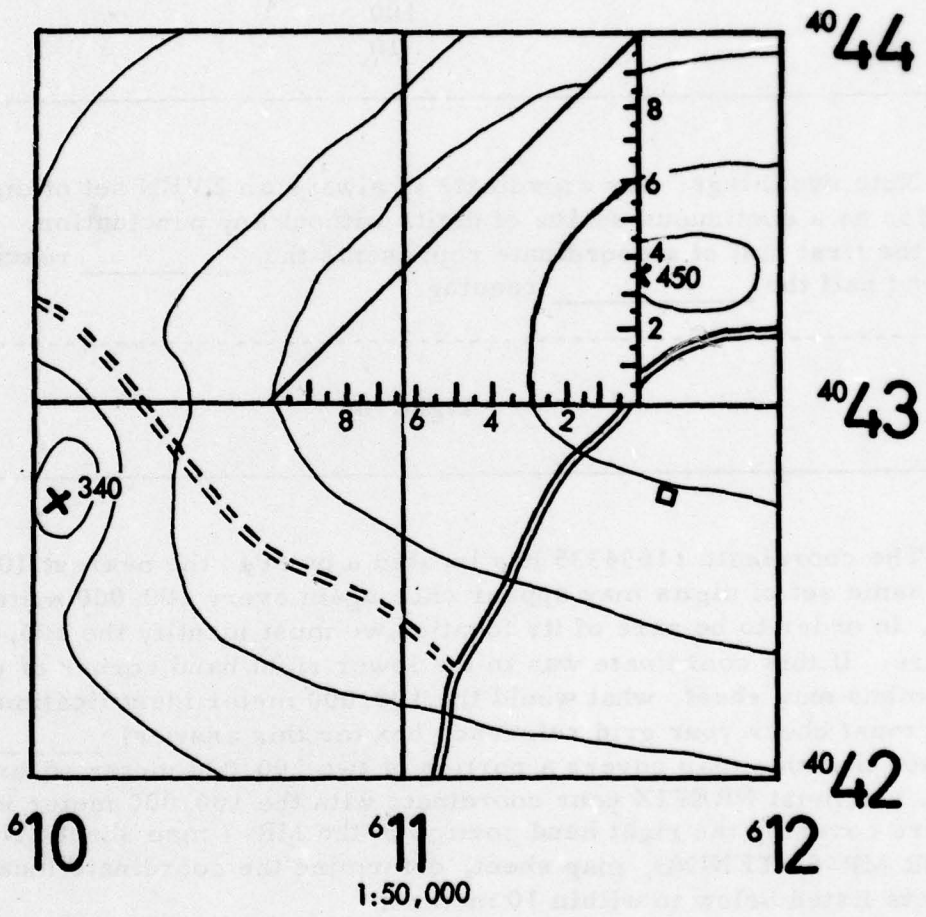

ILLUSTRATION 13A

Now let us review how we read and write a coordinate. To locate a point to the nearest _____ meters, we used a four digit coordinate. To the nearest _____ meters, we used a six digit coordinate. To the nearest _____ meters, eight digit coordinates.

1000
100
10

Note two things: our coordinate is always an EVEN set of digits; and it is written as a continuous series of digits without any punctuation. Remember that the first half of a coordinate represents the _____ reading, and the second half the _____ reading.

right, up

The coordinate 11634335 has located a point to the nearest 10 meters but this same set of digits may appear once again every 100,000 meters. Therefore, in order to be sure of its location, we must identify the 100,000 meter square. If this coordinate was in the lower right hand corner of your MR-7, Columbus map sheet, what would the 100,000 meter identification letters be? (You must check your grid reference box for this answer) _____ We see that this map covers a portion of two 100,000 meter squares. Therefore, you must PREFIX your coordinate with the 100,000 meter identification letters covering the right hand portion of the MR-7 map sheet. NOW, USING YOUR MR-6, TENINO, map sheet, determine the coordinate location of the objects listed below to within 10 meters.

- a. Spot Elevation 382 in Grid Square EG 0390.
- b. Spot Elevation 558 in Grid Square EG 0990.

Identify the symbol located at the following grid coordinate.

- a. EG10338234.

DISTANCE SCALE

GL
EG03899089
EG09789043
Bridge

19

If we located one point on our map and then another nearby, our first thought might be - what is the distance between these two points? In the military, we are interested in two kinds of distances: straight line distance; and road distance. We find that the map maker has provided us with an aid to determine distance. Located in the margin of our map is a GRAPHIC or BAR SCALE. To use the graphic scale, you must first understand MAP SCALE.

20

Map scale is the fixed relationship between map distance and corresponding ground distance. Remember, the main point is the MAP SCALE is the fixed relationship between _____ and _____.

map distance, ground distance

21

The scale is expressed as a representative fraction (RF), the fraction being $RF = \frac{MD \text{ (Map Distance)}}{GD \text{ (Ground Distance)}}$ _____ = $\frac{\text{Map Distance}}{\text{Ground Distance}}$

Representative Fraction

22

This is just another way of expressing scale.

_____ = $\frac{\text{---}}{\text{---}}$

$$\text{Representative Fraction} = \frac{\text{Map Distance}}{\text{Ground Distance}}$$

23

The Representative Fraction appears in the margin of the map as $\frac{1}{50,000}$, $\frac{1}{100,000}$, or 1:50,000. This means that 1 unit of measure on the map represents 50,000 of the same units of measure on the ground. One unit of measure on the map represents 50,000 of the same units of measure on the _____.

Ground

24

$\frac{1}{50,000}$ means that 1 unit of measure on the _____ represents 50,000 of the same units of measure on the _____.

map, ground

25

There is also a graphic scale printed in the margin as a special ruler to measure ground distances on that map. Therefore, all that you need to measure ground distance on a map, is the _____.

graphic scale

26

The graphic scale is used to measure _____ on a map.

ground distance

27

Military maps normally have three graphic scales expressed in miles, meters, and yards. Generally we will find mile, _____, and yard scales represented graphically on a map.

meter

28

The three graphic scales are _____, meters and _____.

miles, yards

29

The graphic scale is simple to use, BUT because of its simplicity, many students make two common errors. TAKE OUT YOUR MR-6, TENINO, map. Note that the graphic scales are in two parts. To the right of zero is the PRIMARY SCALE. To the left of zero is the EXTENSION SCALE. The primary scale is divided into a standard unit of measure; i. e., 1 mile, 1,000 meters, 1,000 yards, 1 nautical mile. The extension scale is divided into tenths of the standard unit of measure; i. e., 1/10 mile, 100 meters, 100 yards, 1/10 nautical mile. The first common error made by a student is that when he takes his measurement, he forgets that the zero mark is within the body of the scale and he will measure from either end of the scale. The other common error is that the student will attempt to measure meters on the yard scale, or vice versa. Remember, start your measurement from the _____ mark, and be sure to use the correct scale.

zero

Now let us see how we would use the graphic scale to measure straight line ground distance. Using Illustration 30A, if we wanted to determine the straight line ground distance from the road junction to the crossroad in meters, we would do the following. First, we take a straight edge (a piece of paper) and place it on our map so that one corner is at the center of mass of one of our points of interest which is in this case the road junction. We insure that the straight edge passes through the center of mass of our other point of interest, the crossroad. We now place a tick mark on our straight edge opposite the center of mass of the crossroad. Then we transfer the straight edge to the METER scale and place the LEFT CORNER of our straight edge at the zero mark. We then read to the right and see that our measurement extends beyond 2,000 meters. We would simply SLIDE the amount of the extension to the LEFT into the extension scale and count over from zero. Our total measurement is _____ meters. Therefore, the straight line ground distance between the two points is _____ meters.

2250

2250

TAKE OUT YOUR MR-6, TENINO MAP AGAIN AND SOLVE THE FOLLOWING PROBLEM:

Determine the straight-line distance in meters from SE483 in grid square EG1297 to SE439 in grid square EG1098.

_____ meters.

2,600 Meters

To measure ROAD DISTANCE, you must first decide on which side of the road to take your measurement. If you try to measure down the center of the road or from one side to another, you will introduce a certain amount of error into your measurement. To minimize this, start your measurement on ONE SIDE of the road, and STAY ON THIS SAME SIDE throughout your measurement. Remember, measure from CENTER OF MASS TO CENTER OF MASS.

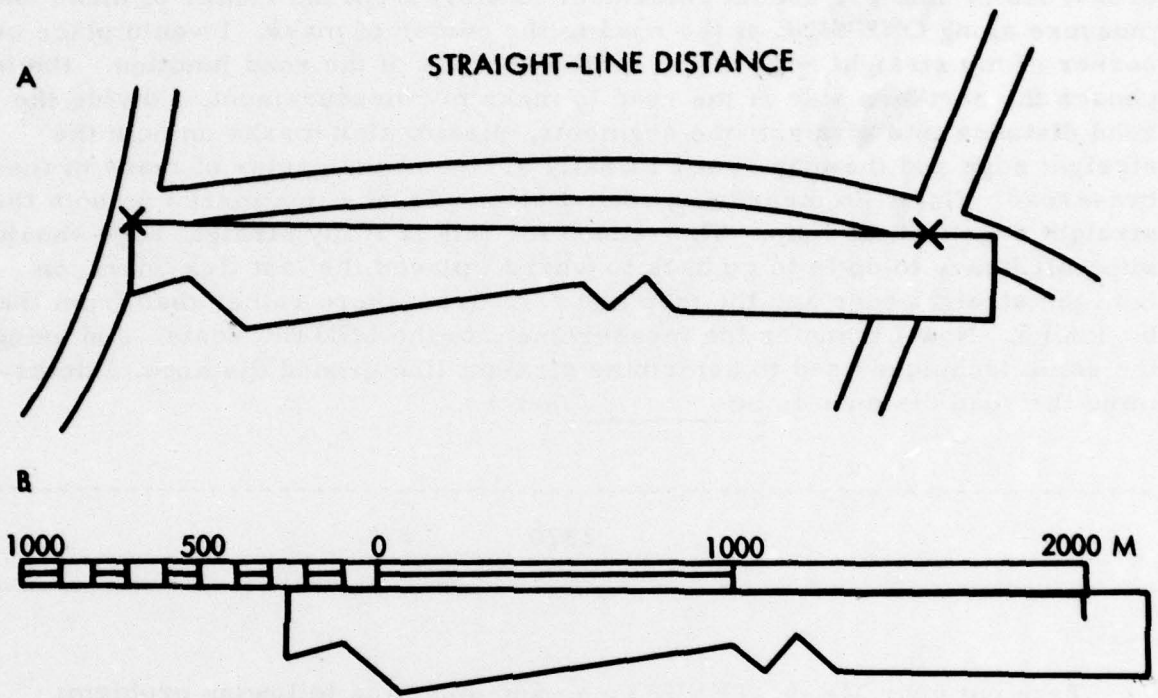

ILLUSTRATION 30A

If I wanted to measure the ROAD DISTANCE from the road junction to the crossroad in meters, I must remember to start from the center of mass and measure along ONE SIDE of the road to the center of mass. I would place one corner of my straight edge at the center of mass of the road junction. Having chosen the northern side of the road to make my measurement, I divide the road distance into straight line segments, placing tick marks on both the straight edge and the map, until I finally arrive at the center of mass of the crossroad. Note: In measuring road distance I place tick marks on both the straight edge and the map. The reason for this is if my straight edge should slip, all I have to do is to go back to where I placed the last tick mark on both the straight edge and the map and start from there rather than from the beginning. Now I transfer the measurement to the METER scale, and using the same technique used to determine straight line ground distance, I determine the road distance to be _____ meters.

2370

Take out your MR-6, TENINO map and solve the following problem:

What is the road distance measured in meters from road jct in grid square EG0284 to BM273 in grid square EG0787 along the Pacific Highway?

_____ meters

6170 meters

IF YOU FEEL YOU NEED MORE WORK IN THIS AREA, OR IF YOU MISSED EITHER OF THE TWO PREVIOUS QUESTIONS, TRY THIS PROBLEM:

What is the road distance in meters from the road junction at EH08020227 to the road junction at EG10749666?

_____ meters

ROAD DISTANCE

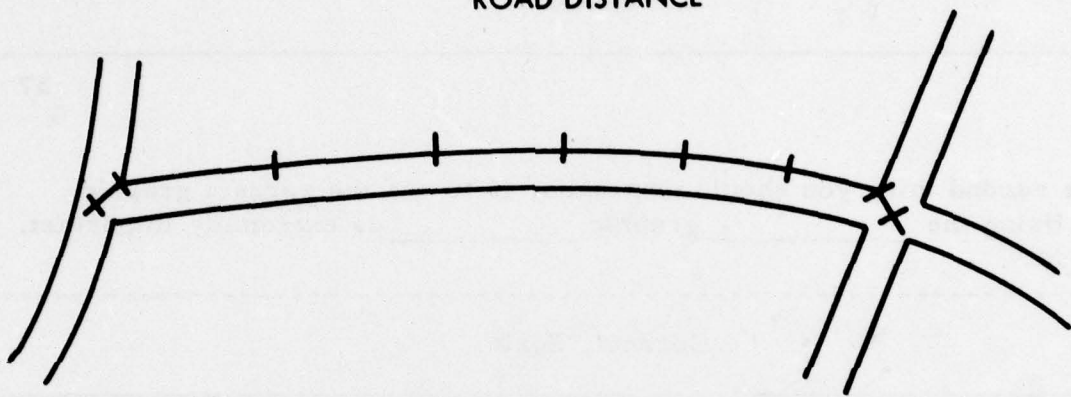

B



ILLUSTRATION 33A

7010 meters

36

There are three things to remember in measuring distance. (1) Measure to center of mass, (2) Use correct graphic scale, and (3) In measuring road distance, measure on one side of the road. The first point to remember is to measure to _____ of mass.

center

37

The second thing you should remember is to use the correct graphic scale. Using the _____ graphic _____ is extremely important.

Correct, Scale

38

The third thing to remember in measuring road distance is to measure on one side of the road. Measure on _____ of the road when measuring _____ distance.

one side
road

39

Remember to: (1) Measure to _____ of mass, (2) Use _____ graphic _____, (3) and measure _____ of the road when measuring road distance.

DIRECTION (AZIMUTH)

Center, correct, scale, on one side

40

Since we were very young we have known that there were 4 directions: NORTH, SOUTH, EAST, and WEST. Imagine yourself in the center of a circle that has been divided into 360 equal parts or DEGREES. This enables you to measure any direction. In map reading we refer to a direction as an AZIMUTH.

41

We define an AZIMUTH as a HORIZONTAL angle measured CLOCKWISE from a BASE direction, and this base direction is always NORTH. Once again, an AZIMUTH is defined as a _____ angle measured _____ from a _____ direction, and this base direction is always _____.

Horizontal, Clockwise, Base, North

42

Let's check this graphically. Fill in the blanks:

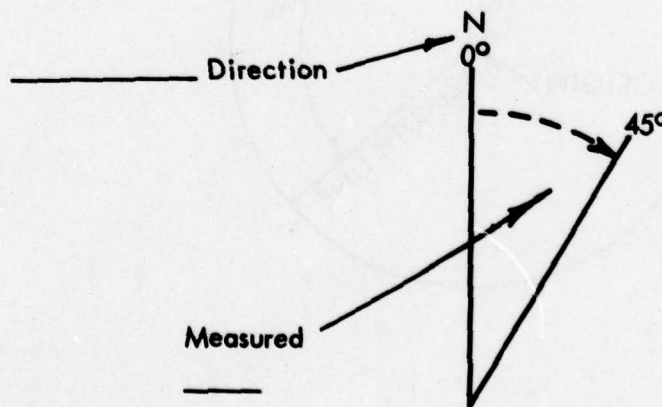

Base, Clockwise, 45°

The unit of angular measurement with which you will be working in map reading is the DEGREE.

The term most commonly used by the military to express a direction is THE AZIMUTH, which as we mentioned earlier, IS A HORIZONTAL ANGLE MEASURED CLOCKWISE FROM A BASE DIRECTION, AND THAT BASE DIRECTION IS ALWAYS _____.

North

All directions or azimuths originate from the center of an imaginary circle which we call the azimuth circle. This azimuth circle is divided into 360 equal parts of measurement called DEGREES.

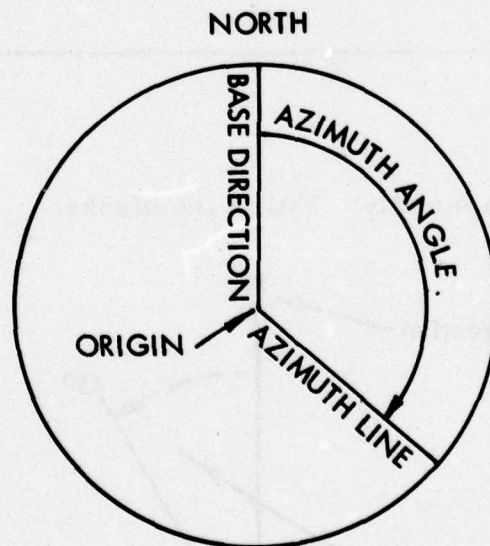

You can observe from this diagram that the origin of the azimuth line is the center of the circle, and that the angle is measured from north, which is at 0 or 360 degrees, CLOCKWISE to the azimuth line.

45

This azimuth circle is divided into 360 EQUAL DEGREES. The degrees are numbered in a CLOCKWISE direction, the zero point being north with east 90° , south 180° , west 270° , and north 360° or 0° .

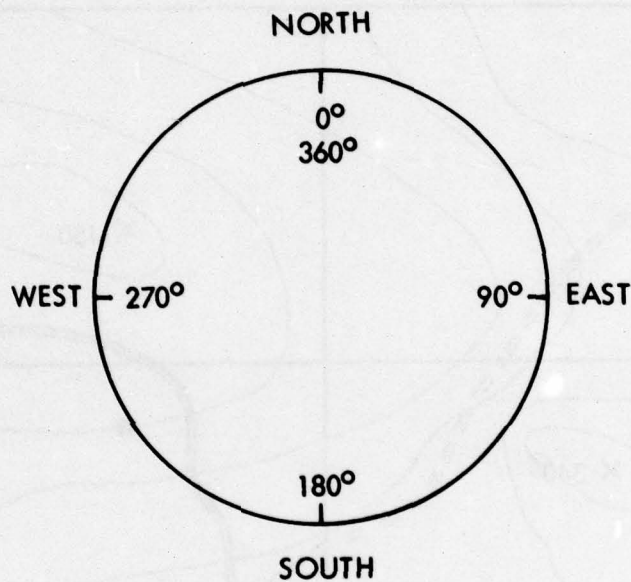

There are _____ degrees in an azimuth _____.

360, Circle

46

Now that you realize that an azimuth is an expression of direction in map reading, and are aware that azimuths originate from the center of an imaginary circle called the azimuth circle, it is time to learn how to MEASURE an azimuth.

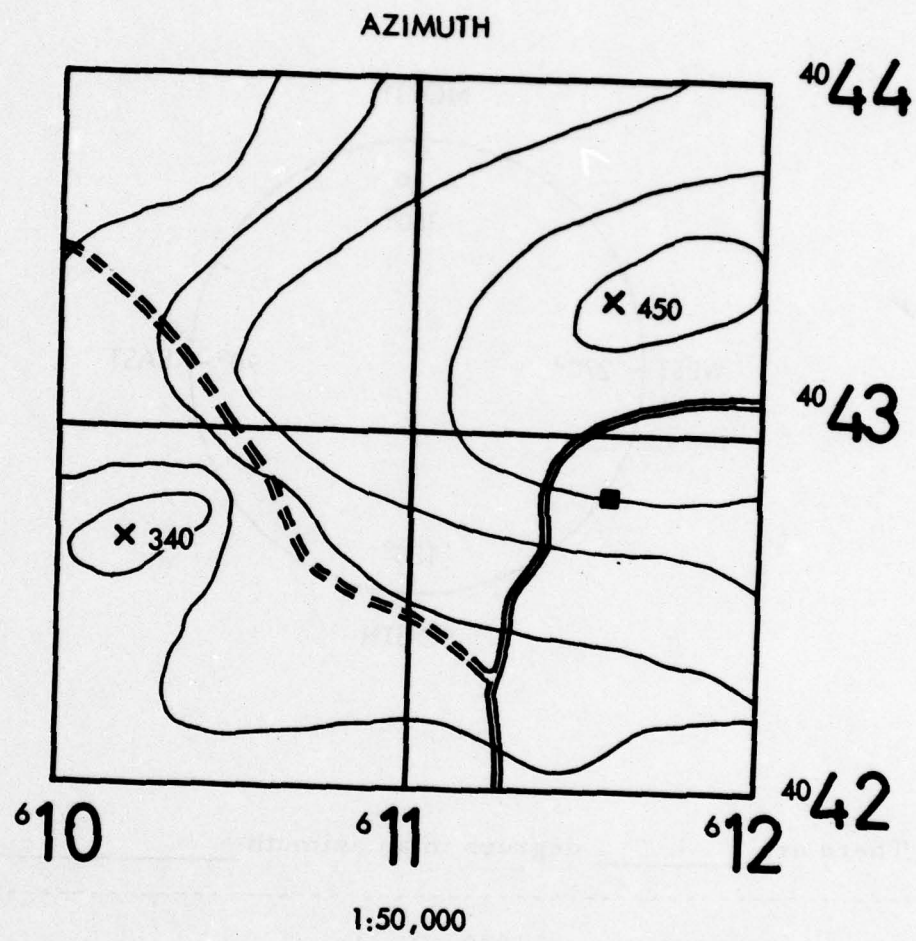

ILLUSTRATION 49A

On a map, azimuths are measured with a protractor. Let's check our protractor.

This protractor represents the azimuth circle. The outer edge is graduated from 0 to 360°, each line represents one degree. A line from 0° to 180° is called the BASE line of the protractor and the INDEX or center, of the protractor is at the point of intersection of the 0-180° base line and is a 90° - 270 line.

48

When using the protractor, the base line of the protractor is always oriented parallel to a north-south grid line, the 0° or 360° end toward the top or north end of the map and the 90° mark is to the right.

49

For these frames on MEASURING an azimuth, use illustration 49A. To measure an azimuth from SE 340 to SE 450:

1. Plot a line connecting the centers of mass of the two points.

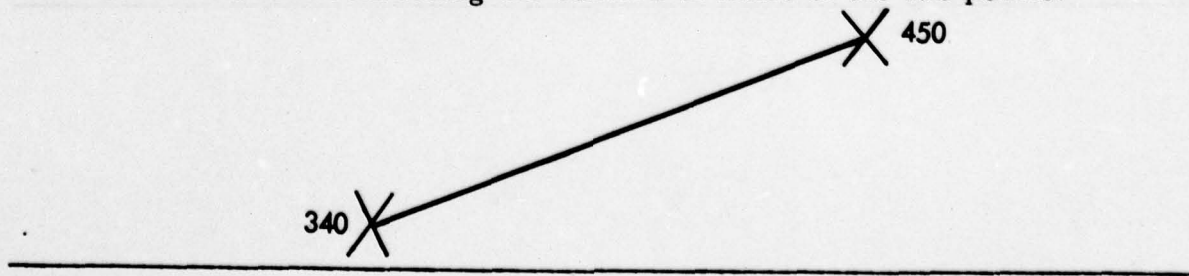

50

2. Place the index mark at the center of mass of the point from which you are measuring, insuring that the 0° - 180° line of the protractor, or base line is PARALLEL to a north-south grid line. (In this case your closest north-south grid line will be the 10 line.)

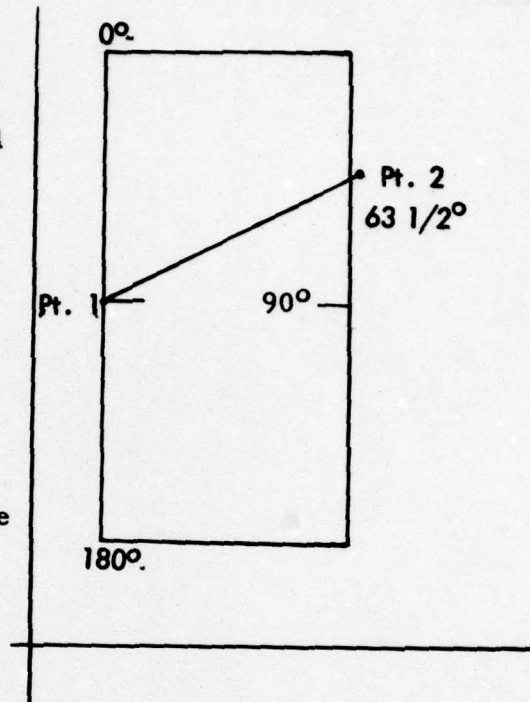

3. Read the azimuth at the point where the line intersects the scale of the protractor. In measuring azimuth, read CLOCKWISE or easterly, and remember that in order to have an accurate measurement, the base line of the protractor MUST be PARALLEL to a north-south grid line.

51

Note that your measurement came out to $63 \frac{1}{2}$ degrees. Whenever measuring an azimuth, you always read to the nearest $\frac{1}{2}$ degree.

52

Now that you have learned to read an azimuth on a map, you will learn how to plot an azimuth.

To PLOT an azimuth on a map:

1. Place the protractor on the map with the index mark at Point Number 1 with the Base parallel to a north south grid line, the 0° mark oriented to the top of the map and 90° to the right.

2. Place a dot on the map at the desired azimuth on the scale. In this case our desired azimuth is 45° .

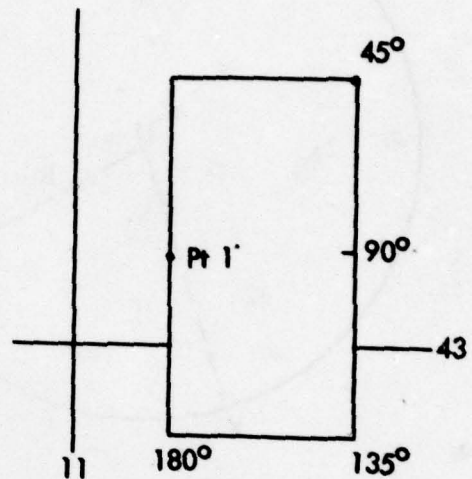

Finally, remove the protractor and connect point number 1 and the dot with a straight line.

54

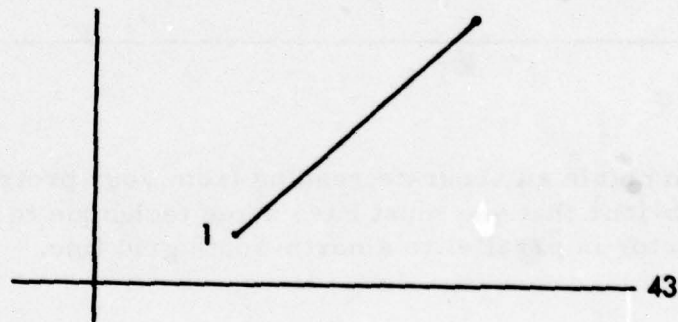

The line you have plotted is an azimuth line of 45° .

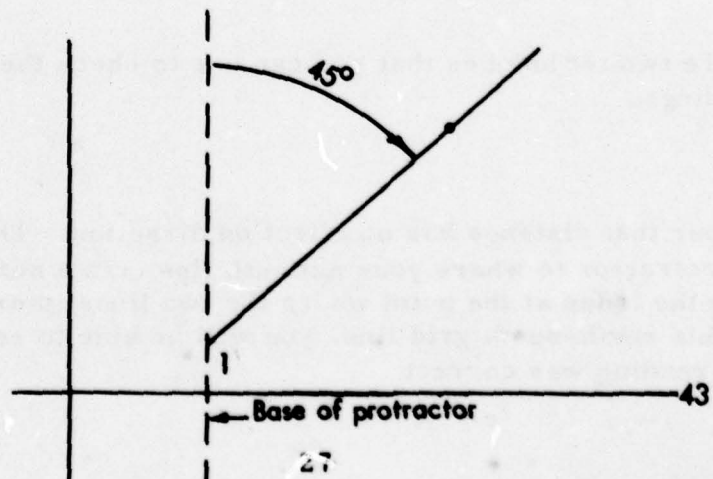

27

55

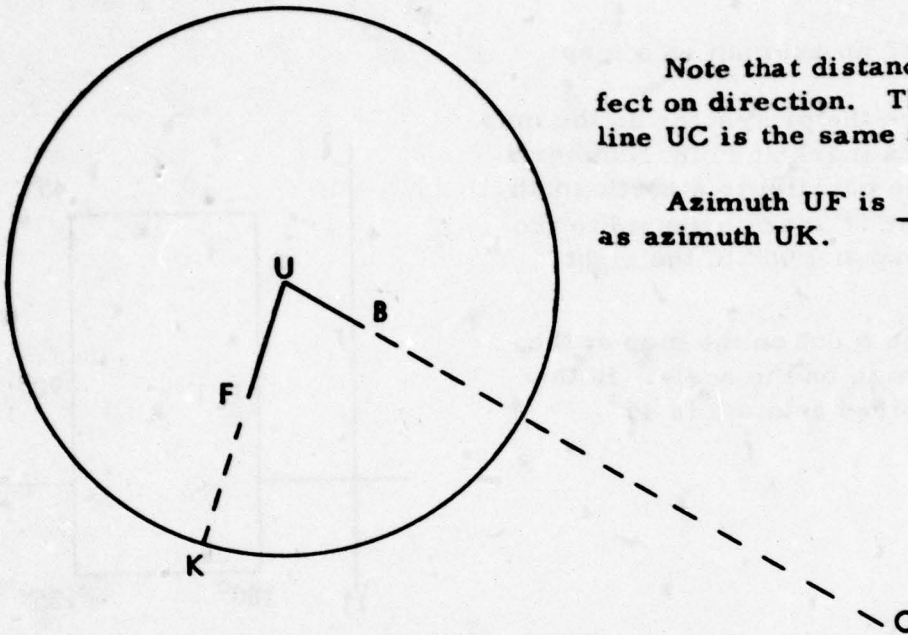

Note that distance has no effect on direction. The azimuth of line UC is the same as line UB.

Azimuth UF is _____ as azimuth UK.

The same

56

To obtain an accurate reading from your protractor to the nearest $1/2^\circ$, it is obvious that you must have some technique to check that the base of the protractor is parallel to a north-south grid line.

57

There are two techniques that you can use to check the accuracy of your azimuth readings.

Remember that distance has no effect on direction. Therefore, if you move your protractor to where your azimuth line cuts a north-south grid line, placing the index at the point where the two lines intersect and the base directly on this north-south grid line, you will be able to see whether your initial azimuth reading was correct.

Observe that if you place your protractor on your map, it will be larger than any of your grid squares, and that it will be cut at the top and bottom by at least one north-south grid line.

All you would have to do is to count over from the 0° mark and from the 180° mark to this north-south grid line, and rotate your protractor until you have the same number of tick marks at the bottom and top of your protractor.

When the number of tick marks is equal, and the index mark is still at the center of mass of your initial point, then the base of your protractor will be parallel to a north-south grid line.

Supposing you, the platoon leader, move from your original position along a given azimuth to another position - let us say an observation post.

Now that you have performed your duties at the observation post, you must move back to the original position. What direction will you follow? Certainly not the azimuth you had been using.

You will determine the BACK AZIMUTH of the azimuth that brought you to the observation post, and follow it back to your original position.

The back azimuth of a line differs from its forward azimuth by exactly 180° .

A back azimuth is easy to see and read on an azimuth circle:

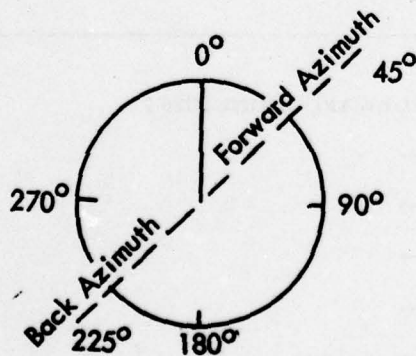

On the illustration, a back azimuth is merely the projection of the forward azimuth from its origin to the opposite side of the azimuth circle. Hence, a forward azimuth of 45° has a back azimuth of 225° .

A forward azimuth of 360° (or 0°) has a back azimuth of _____.

180°

62

There are three rules for determining back azimuth.

They are: 1. If the forward azimuth is SMALLER than 180°, the back azimuth will equal the forward azimuth PLUS 180°.

You have a forward azimuth of 20°. What is its back azimuth? _____

200°

63

2. If the forward azimuth is LARGER than 180°, the back azimuth will equal the forward azimuth MINUS 180°.

You have a forward azimuth of 300°. What is its back azimuth? _____

120°

64

Finally, Rule 3: If the azimuth is 180°, the back azimuth is 0° or 360°.

You have a forward azimuth of 180°. Its back azimuth is _____° or _____°.

0° or 360°

65

Determine the back azimuth of these forward azimuths:

35° _____
340° _____
210° _____
125° _____
180° _____

Forward Azimuth

35°
340°
210°
125°
180°

Back Azimuth

215°
160°
30°
305°
0° or 360°

Let us summarize! Remember, if the forward azimuth is less than 180°, the back azimuth is the forward azimuth 180°. 66

If the forward azimuth is more than 180°, the back azimuth is the forward azimuth 180°.

Plus, Minus

SECTION II
GRID-MAGNETIC ANGLE

67

Remember, when we defined AZIMUTH we said it was measured from the base direction of NORTH. In this world of ours we have THREE NORTHS and you see them graphically represented in the DECLINATION DIAGRAM of your map. Check your MR-6, Tenino map, and you'll see that the 3 norths are:

- (a) True NORTH -- a line from any position on the earth's surface to the geographic north pole. True north is symbolized by a line with a star at the apex.
- (b) Magnetic North -- the direction in which the magnetic arrow of the magnetic compass points. Magnetic north is symbolized by a half arrowhead (\uparrow) at the apex of a line.
- (c) Grid North -- the north that is established by the grid lines on the map. Grid north is symbolized by the letters GN at the apex of a line.

IDENTIFY THESE BASE DIRECTIONS:

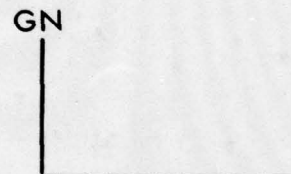
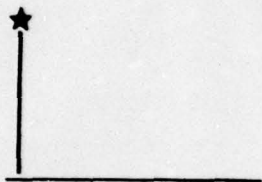

True, Magnetic, Grid

If we are to be competent map readers, we must understand the RELATIONSHIP between the 3 base directions.

The relationship between these 3 base directions is graphically represented by the declination diagram on your map sheet.

At this time, we are really interested in the two base directions of GRID NORTH and MAGNETIC NORTH, or the angular difference between the two as measured from GRID NORTH which is called the GRID-MAGNETIC or G-M ANGLE, because it will affect how accurately we use our map in the field.

The circle in illustration 70A represents the world. We know that the surface of the world is represented by many map sheets, one of which is illustrated inside the circle.

Map sheets are gridded. Our map sheet has several North-South and several East-West grid lines on it.

We extended one of these NORTH-SOUTH grid lines to the north. This gives us our BASE DIRECTION of GRID NORTH which is used as the base direction of north on our map. We see that this base direction is indicated in our declination diagram by a line with the letters GN at its apex.

Remember, the _____ direction of _____ north is used as the base direction on our map.

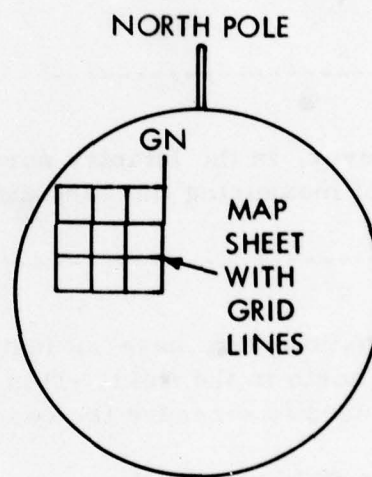

70A

Base, Grid

This base direction of grid north is indicated in the _____ diagram by the letters _____ at the apex of a straight line.

Declination, GN

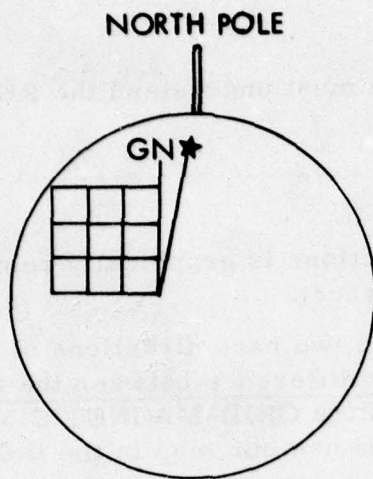

One of our other base directions is to the NORTH POLE, and is indicated in the declination diagram by a straight line with a STAR at its apex. This is the base direction of TRUE NORTH.

However, in the Infantry normally we are not issued an instrument capable of measuring the base direction of TRUE NORTH, so let's forget about it.

We do, however, have an instrument in the Infantry with which we can measure north in the field! This instrument is the LENSATIC COMPASS, and it is used to measure the base direction of MAGNETIC NORTH.

In the field, we use the _____ COMPASS to measure the base direction of _____ NORTH.

Lensatic, Magnetic

The base direction of MAGNETIC NORTH is indicated in our declination diagram by a straight line with a half arrow at its apex. This half arrow is comparable to the north-seeking magnetic arrow on our lensatic compass, and we know that this north-seeking arrow is attracted to the earth's magnetic field which has its terminus in the Hudson Bay area.

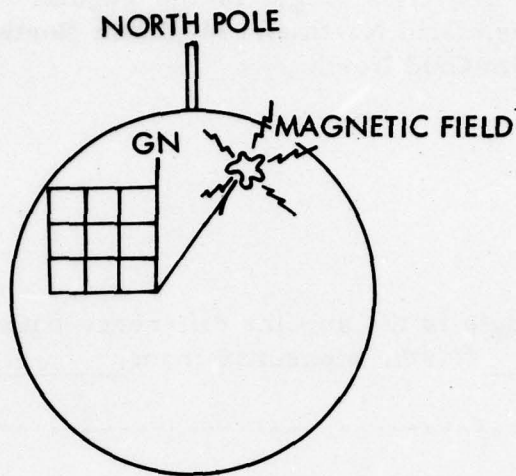

Now we have the two base directions we are really concerned with: **GRID NORTH** for our **MAP**; and **MAGNETIC NORTH** for the **GROUND**.

Remember, **GRID NORTH** is used as the base direction on our _____,
and **MAGNETIC NORTH** as the base direction on the _____.

Map, Ground

The base directions you will use in map reading are **Magnetic North** and **Grid North**: the **Magnetic North** when working in the field; and the **Grid North** when working on the map. We are primarily interested in, however, the angular difference between **GRID North** and **MAGNETIC North** as measured **FROM Grid North**. This angle is called the **GRID-MAGNETIC** or **G-M Angle**, and has a distinct effect on how accurately we use a map in the field.

78

Once again, the G-M Angle is the angular difference between Grid North and Magnetic North as measured from Grid North.

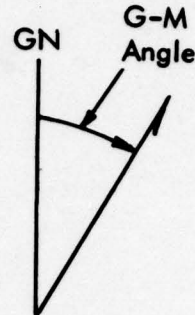

The G-M Angle is the angular difference between _____ North and _____ North, measured from _____ North.

Grid, Magnetic, Grid

79

Now recall that we said we were primarily interested in the angular difference between grid north and magnetic north as measured from grid north which we called the G-M Angle. When we talk about the G-M Angle, we must consider two things: its VALUE and its DIRECTION.

The G-M Angle must always have a _____ and a _____.

Value, Direction

80

The value can be found in the declination diagram of your map sheet. The direction will depend on which side of GRID NORTH the MAGNETIC NORTH-SEEKING ARROW is attracted. Illustration number 81A shows a G-M Angle value of 15° , and is EASTERLY because the MAGNETIC NORTH-SEEKING ARROW is attracted to the RIGHT side of GRID NORTH or to the EAST of GRID NORTH.

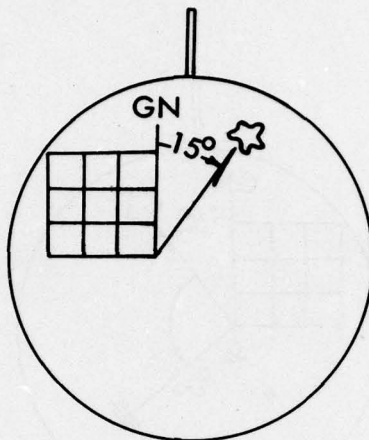

ILLUSTRATION 81A

81

Once again, the VALUE of our G-M Angle is found in the _____ diagram, and its direction is determined by which side of _____ north the _____ north-seeking arrow is _____.

Declination, Grid, Magnetic, Attracted

82

Now, let us see exactly how this G-M Angle affects our accurate use of a map in the field. We will assume that in the lower right hand corner of the map sheet in our illustration, there is represented an observation post. The observer at this observation post has just detected an enemy gun position to his front at a range of 1000 meters.

Using his lensatic compass, he measures an azimuth from his base direction of MAGNETIC NORTH to the enemy gun position to be 90 degrees. This is illustrated below.

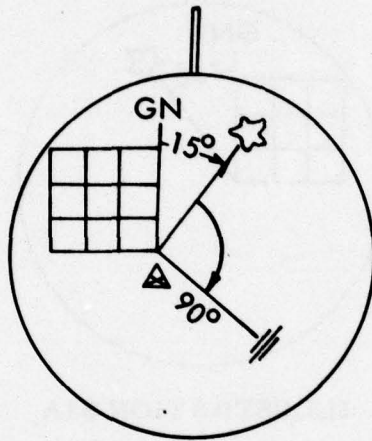

The observer calls this information into operations, and it is acknowledged by a clerk. The clerk knows that whenever he assists in plotting locations of units on the operations map, that he always used the base direction of GRID NORTH to determine direction on the map, and this is exactly the way the clerk plots the 90 degree azimuth received from the observer.

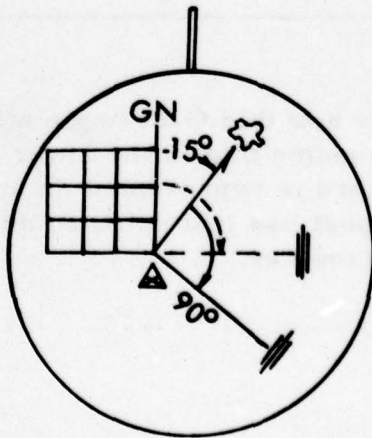

The clerk calls this information into the mortar section and they take the gun position under fire, BUT they miss the target! By how much? By the VALUE of the G-M Angle. Our clerk failed to realize that the azimuth sent to him was a MAGNETIC azimuth and had to first be converted to a GRID azimuth. His failing to consider the G-M Angle, caused him not to convert a MAGNETIC azimuth into a GRID azimuth.

To convert a _____ azimuth to a _____ azimuth or vice versa, you must consider the _____ of the G-M Angle.

Magnetic, Grid, Value

Let us look at the illustration and see what the correct solution should have been.

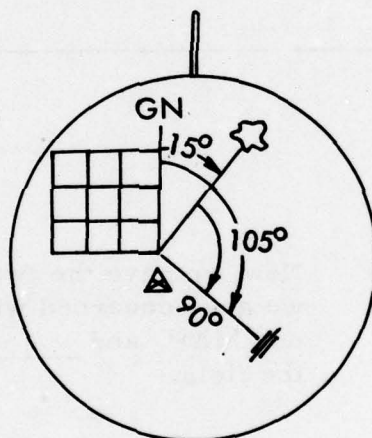

$$90^{\circ} + 15^{\circ} = 105^{\circ}$$

The correct answer is 105 degrees because we can see that the grid azimuth is LARGER than the magnetic azimuth by the value of the G-M Angle, so we must ADD 15 degrees to 90 degrees to determine the correct GRID azimuth to the enemy gun position.

It is obvious that everytime we want to convert a magnetic azimuth to a grid azimuth, or vice versa, we do not have to draw a picture of the world! All we have to do is extract from our diagram the necessary information in order to make correct conversions.

The first thing we want to extract is the _____ line.

Grid North

88



Now we extract the _____ north line and place it to the _____ of grid north because it is _____ to the EAST.

Magnetic, Right, Attracted

89



Now we have the two base directions we are concerned with: GRID NORTH for our MAP, and _____ NORTH for the field.

MAGNETIC

90

Remember, we said we were primarily interested in the angular difference between these two base directions which we called the _____ Angle, as measured from _____ north to magnetic north.

We further said a G-M Angle must have two things: a _____ and a _____.

G-M, Grid, Value, Direction

91

Since we are extracting from our picture of the world, we find the value for our G-M Angle will be 15 degrees, and the direction we already know is

_____.

Easterly

92



The next step is to extract our azimuth line, and then complete our diagram by drawing in the arcs to represent grid and magnetic azimuths.

93

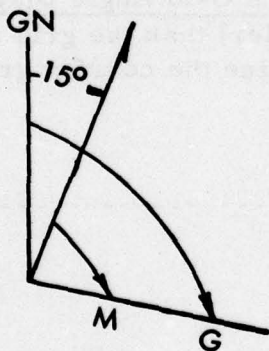

This diagram as it is now is called a G-M ANGLE DIAGRAM.

By simply substituting into the G-M _____ the known azimuth, we can determine the value of the unknown azimuth.

Angle Diagram

94

Let us see how the G-M Angle Diagram does help us to convert azimuths accurately.

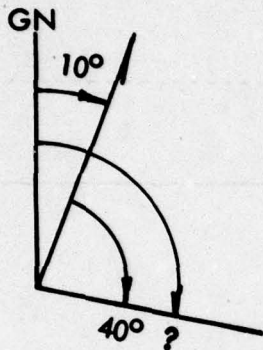

Magnetic Azimuth = 40°
Grid Azimuth = _____

50°

95

Our grid azimuth is 50° because by looking at the G-M Angle Diagram we see that the magnetic azimuth is (larger or smaller) than the grid azimuth by the value of the G-M Angle, therefore, to determine the correct grid azimuth, we ADD 10° to our magnetic azimuth.

Smaller

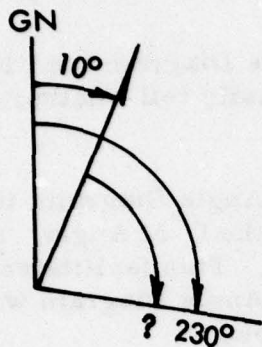

Let us make our magnetic azimuth the unknown this time.

Grid azimuth = 230°
 Magnetic azimuth = _____

 220°

97

220° is correct because the G-M Angle Diagram tells us that the grid azimuth is (larger or smaller) than our magnetic azimuth. Therefore, we must (add or subtract) the value of the G-M Angle from the grid azimuth to determine the correct magnetic azimuth of 220° ?

Larger, Subtract

98

Will this procedure work with a WESTERLY G-M Angle? Let us try it!

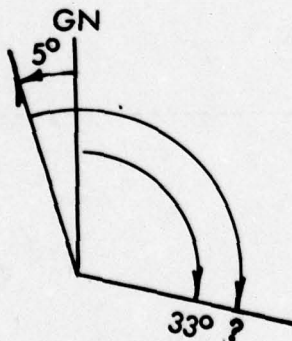

Grid azimuth = 33°
 Magnetic azimuth = _____

 38°

By simple **SUBSTITUTING** into our G-M Angle Diagram the **KNOWN** azimuth, and **LOOKING** at the diagram, we can easily tell whether we have to **add** or **subtract** the value of the G-M Angle.

Remember, **TAKE TIME** to construct a G-M Angle Diagram; it only takes seconds, and it will tell you how to correctly use the G-M Angle. Also, have your largest angle represented by the largest arc. This facilitates identifying which of the two azimuths is larger. Your G-M Angle Diagram would then be placed in the margin of the map as illustrated below.

WESTERLY

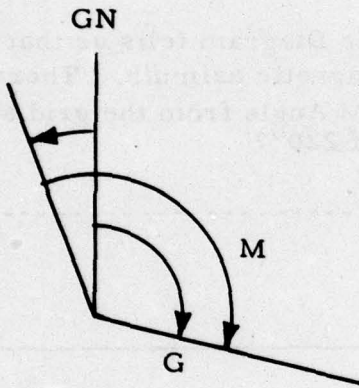

EASTERLY

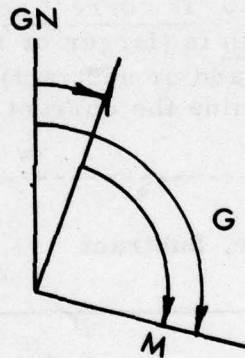

When you will be using the same map frequently, you should place, somewhere in the margin, a **CONVERSION TABLE** that will tell you quickly whether to add or subtract the G-M Angle. This conversion table should read as follows:

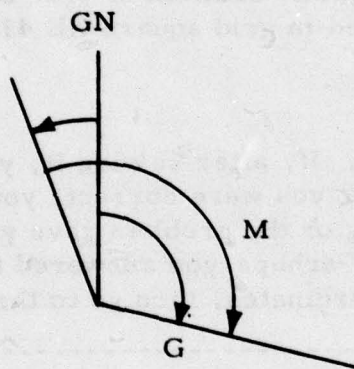
WESTERLY

To convert:
 Mag to Grid **SUB** GM ANGLE
 Grid to Mag **ADD** GM ANGLE

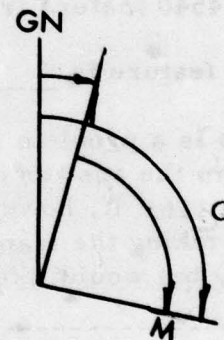
EASTERLY

To convert:
 Mag to Grid **ADD** GM ANGLE
 Grid to Mag **SUB** GM ANGLE

SECTION III POLAR COORDINATES

101

A point on the map may be determined or plotted from a known point by giving a direction and a distance along that direction line. This method of location is known as polar coordinates.

The method of locating a point on the map from a known point with a given direction, and a given distance along that direction line is _____

polar coordinates

102

Open the RON Map MR-5 in front of you.

Identify the feature located along a magnetic azimuth of 172° at a distance of 4540 meters from VABM 593 located in grid square XE 4183.

The feature is _____.

This is a problem in polar coordinates. If, after solving it, you determine from the answer on the next frame that you were correct, you may skip to frame 116. If, however, you were wrong or the problem gave you difficulty, continue taking the frames consecutively. Perhaps you answered the question correctly but would like to review polar coordinates, then go to the next frame.

VABM 226 (XE 4179)

103

There are three knowns in Polar Coordinates: (1) starting point, (2) direction, and (3) distance.

You apply Polar Coordinates in day-by-day occurrences.

Suppose you are standing on a street corner and someone asks you how to get to a particular building. You may reply, "Well, from here (starting point) walk east (direction) and go three full blocks (distance). It's the building on the corner. You can't miss it."

That is an application of polar coordinates, because the person receiving your directions will apply three knowns: _____, _____, and _____ to locate a particular point.

starting point, direction, distance

104

Let us apply Polar Coordinates to map reading, and more specifically, to the problem in frame 102.

You know that Polar Coordinates is simply the application of three knowns (starting point, direction, and distance) to locate a specific point on a map.

105

Refer to Frame 102.

The purpose of the problem is to locate and identify a specific feature by applying three knowns. They are _____, _____, _____, and _____.

starting point, direction, distance

106

Continue with frame 102. In that problem what is the starting point?

Starting point: _____

VABM 593

107

Correct. The problem states that the feature you are looking for is at a point measured at a certain direction and distance from VABM 593.

Now, go back to Frame 102 and determine the distance given.

Distance: _____

4540 meters

108

The problem states that the feature you are looking for is located at a distance of 4540 meters from the starting point, which is VABM 593.

Finally, determine the direction.

Direction: _____

172° magnetic azimuth

109

The problem states that the unidentified feature is located along a magnetic azimuth of 172°.

Our knowns are:

Starting Point: VABM 593
Direction: Mag. Az. 172°
Distance: 4540 meters

The first step would be to plot the azimuth on the map from the starting point, but since the azimuth given is a magnetic azimuth, and we want to plot it on a map, it must be converted to a _____ azimuth.

grid

110

Since the RON map has a G-M angle of 1° Westerly, the grid azimuth will be 1 degree (more or less) than the magnetic azimuth?

less

111

The grid azimuth will be 171 degrees.

Plot a grid azimuth of 171° on your RON map, starting from VABM 593 in grid square XE 4183.

Now measure a distance of 4540 meters from the starting point and along that azimuth. The feature located at a distance of 4540 meters from the starting point is _____.

VABM 226

112

IF YOU WERE INCORRECT, RETURN TO FRAME 102 AND REREAD THE FRAMES.

If you feel that you need just a little more work in this area, work these problem. If not, turn to Frame 114.

Identify the feature located along a magnetic azimuth of 318° at a distance of 4230 meters from VABM 68 in grid square XE 4972.

FORD XE 4675

113

Identify the feature located along a magnetic azimuth of 188° at a distance of 3050 meters from VABM 226 in grid square XE 4179.
XE 4179.

SE 142 (XE 4176)

INTERSECTION

114

Distant or inaccessible objects can be located on a map by intersecting lines from two known points. For example, a magnetic azimuth from a known observation post to a distant point is converted to a grid azimuth and drawn on the map. Another magnetic azimuth from another observation post to the same distant point is converted to a grid azimuth and drawn on the same map. Where the two lines intersect on the map is the location of the distant point.

The method of locating a point on a map by intersecting lines from two known points is called INTERSECTION.

115

USE RON MAP MR-5

Identify the feature located on a magnetic azimuth of 167° from SE 786 in XE 4688 and a magnetic azimuth of 29° from SE 66 in XE 4474.

Feature: _____

This is a problem in intersection. If, after solving it, you determine from the answer on the next frame that you were correct, you may skip to Frame 124. If, however, you were wrong, or the problems gave you difficulty, continue taking the frames consecutively. Perhaps you answered the question correctly but would like to review intersection. Turn to the next frame.

116

There are four knowns in INTERSECTION: two known starting points, and two known directions. We will assume, for the sake of illustration, that you are a member of a rifle company which has outposts at two locations in a particular area. See illustration below.



117

Remember intersection is the process of locating distant or inaccessible objects by _____ lines from two known points. Assume the unknown point is point X in the illustration below.

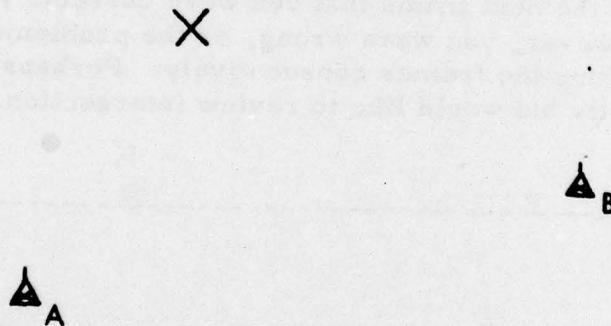

intersecting

118

First plot outposts A and B on the map, then have magnetic azimuths taken from both outposts to point X. These azimuths, taken in the field with a compass, will then have to be placed on a map. Since the azimuths taken with a compass are _____ azimuths, they must be converted to _____ azimuths to be placed on a map.

Magnetic, Grid

119

Suppose the distant point is measured at a magnetic azimuth of 18° from Outpost A and 270° from Outpost B. Assuming this locale is on your RON map, convert the magnetic azimuths to grid azimuths by referring to the current G-M angle on the MR-5. Grid azimuths for these magnetic azimuths are: 18° _____

270° _____

Draw these azimuths on the map. Be sure your measurements are always taken from center of mass.

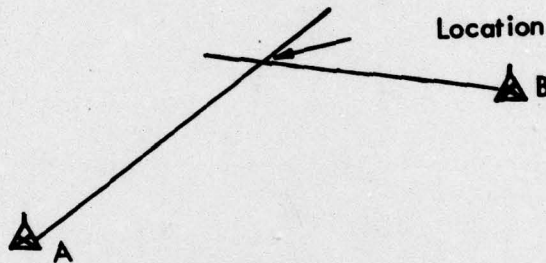

Where the two grid azimuths intersect is the exact location on the map of the distant or inaccessible point. If you feel you need more work on intersection, work these problems. If not, go on to frame 122.

 17°
 269°

120

USE RON MAP MR-5

Identify the feature located on a magnetic azimuth of $163\frac{1}{2}^\circ$ from VABM 662 in XE 3789 and a magnetic azimuth of $315\frac{1}{2}^\circ$ from VABM 593 in XE 4183.

SE 413 (XE 3886)

Identify the feature located on a magnetic azimuth of 152° from SE 158 in XE 4982, and a magnetic azimuth of $198\ 1/2^{\circ}$ from VABM 630 in XE 5381.

PAGODA (XE 5277)

RESECTION

122

RESECTION is a method of finding one's own (unknown) position by sighting on two known features.

In the process of resection, you determine your position by sighting on _____ features, visible both on the ground and on the map.
(number) _____

two, known

123

USE RON MAP MR-5

The magnetic azimuth from your position to VABM 226 in XE 4179 is $16\frac{1}{2}^{\circ}$, and to SE 298 in XE 3577 is $311\frac{1}{2}^{\circ}$. What is your location? (Identify the feature)

This is a problem in resection. If, after solving it, you determine from the answer on the next frame that you were correct, you may skip to Frame 136. If, however, you were wrong, or the problem gave you difficulty, continue taking the frames consecutively. Perhaps you answered the question correctly, but would like to review resection. Turn to the next frame.

VABM 326 (XE 4073)

Basically, this is the principle of resection:

You are located at Point A but your position is unknown. To your front you see a bridge and a church.

Notice that if lines were drawn from these two features back to your location, they would resect. Where they resect is your location.

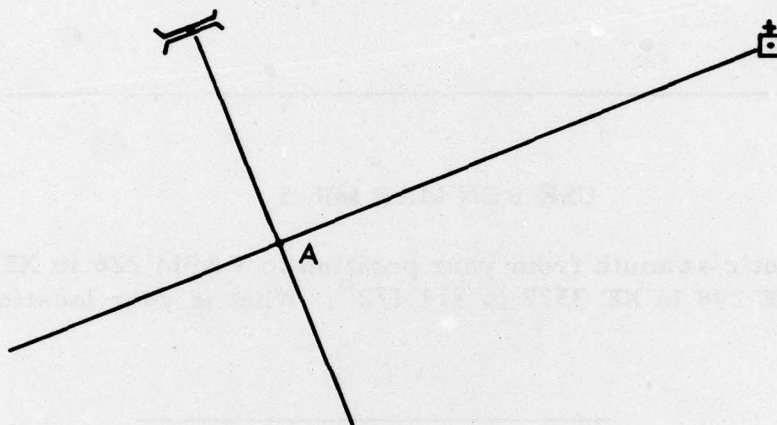

1. The first step in resection is to locate two or more objects on the ground that can be identified on the map.
2. Then, with the compass, measure an azimuth to each of the points on the ground. Convert these magnetic azimuths to grid azimuths, then to back azimuths.
3. From the two known locations on the map, plot these two back azimuths until the lines resect.

The point where these two lines cross is your position!

It's important to remember that after you've taken magnetic azimuths to the known locations, these magnetic azimuths must be converted to _____ azimuths (to place on a map), then to _____ azimuths (so the lines will resect at your location).

grid, back

Let us refer to that problem on resection.

The magnetic azimuth from your position to VABM 226 in XE 4179 is $16\ 1/2^\circ$, and to SE 298 in XE 3577 is $311\ 1/2^\circ$. What is your location? (identify the feature)

Tackle the problem step-by-step. First, you have located two points on the ground that can be identified on the map. They are _____ and _____.

 VABM 226
 and
 SE 298

Next, measure the magnetic azimuth to each of these points. That's been done. These magnetic azimuths are:

To VABM 226 _____^o

To SE 298 _____^o

 $16\ 1/2^\circ$
 $311\ 1/2^\circ$

The next steps are to convert these magnetic azimuths to _____ azimuths, then to _____ azimuths.

Use the current G-M Angle for the RON Map, MR-5

 grid, back

129

The RON Map has a G-M Angle of 1 degree Westerly, so the grid azimuth will be 1 degree less than the magnetic azimuth, or $15\ 1/2^\circ$ to VABM 226 and $310\ 1/2^\circ$ to SE 298.

Now we have to convert these grid azimuths to back azimuths.

The grid azimuth to VABM 226 is $15\ 1/2^\circ$ which is less than 180° . So its' back azimuth will be $15\ 1/2^\circ$ 180°.
(plus or minus)

plus

130

The back azimuth of $15\ 1/2^\circ$ is $15\ 1/2^\circ + 180^\circ$ or $195\ 1/2^\circ$.

The grid azimuth to SE 298 is $310\ 1/2^\circ$. It is larger than 180° , therefore its' back azimuth will be $310\ 1/2^\circ$ 180°.
(plus or minus)

minus

131

The back azimuth of $310\ 1/2^\circ$ is $310\ 1/2^\circ - 180^\circ$ or $130\ 1/2^\circ$.

The final step in resection is to plot these back azimuths on the map from their respective known locations. Remember, plot from center of mass.

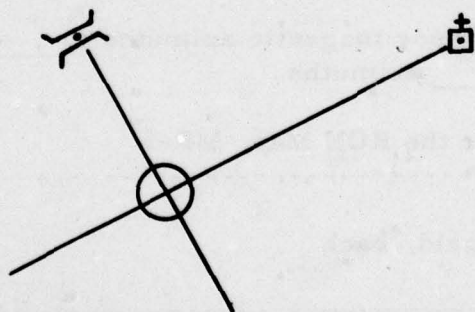

Where the two back azimuths resect on the map is your location.

If you had trouble with resection, or just want a little review, here are two more problems for you.

A patrol leader determines the magnetic azimuth from his position to the bridge in XE 5682 to be $104\frac{1}{2}^{\circ}$ and the magnetic azimuth from his position to the Pagoda in XE 5687 to be 66° . What is his location?

	BRIDGE	PAGODA
Magnetic azimuth	_____	_____
Grid azimuth	_____	_____
Back azimuth	_____	_____

SE 728 (XE 4984)

One more for practice. If you feel you have a full understanding of resection, skip this frame.

From your unknown position, you determine the magnetic azimuth to the Pagoda in XE 3484 to be 15° , and the magnetic azimuth to Hill 802 in XE 4084 is 66° . What is your location?

	PAGODA	HILL 802
Magnetic azimuth	_____	_____
Grid azimuth	_____	_____
Back azimuth	_____	_____

VABM 244 (XE 3381)

MODIFIED RESECTION

134

If you should be located on a linear feature that you can locate on the map, i. e., road, stream, ridge, you can utilize another method to locate your own position. This method is called modified resection.

135

OPEN YOUR RON MAP, MR-5

You are located on a CART TRACK running generally West-East through XE 4480, XE 4580, XE 4680, XE 4679 and XE 4779. The magnetic azimuth from your position to SE 793 in grid square XE 4684 is 7° . What is your location to within 10 meters?

This is a problem in MODIFIED RESECTION. If, after solving it, you determine from the answer on the next frame that you were correct, you may skip to Frame 146. If however, you were wrong or the problem gave you difficulty, continue taking the frames consecutively. Perhaps you answered the question correctly but would like to review modified resection. Go to the next frame.

XE 46048016

136

A method of locating your position on a map when you are located on a road, stream, or other linear feature is modified resection.

One method of locating your position on a map when you are located on a prominent linear feature is _____.

Modified resection

137

Modified resection is really only half the process of resection. Remember, in resection you resected the back azimuths of sightings on two known features or locations. Modified resection, however, is merely the resecting of the back azimuth from a known point with the linear feature on which you are located.

138

Let us refer again to the problem on modified resection in Frame 146.

Remember to tackle the problem step-by-step. You know you are located along a particular road and you have located a point on the ground that can be identified on the map. It is _____.

SE 793

139

Next, you must determine the magnetic azimuth to this point. That's been done. It is _____.

7°

140

The next step is to convert the magnetic azimuth to a _____ azimuth, then to a _____ azimuth.

**DON'T FORGET TO USE THE CURRENT G-M ANGLE FROM YOUR
RON MAP!**

Grid, back

141

The RON map has a G-M angle of 1 degree Westerly, so the grid azimuth will be 1 degree less than the magnetic azimuth, or 6° .

Now we have to convert this grid azimuth to a back azimuth.

The back azimuth of 6° is _____.

 186°

142

The back azimuth of 6° is $6^{\circ} + 180^{\circ}$ or 186° .

The final step in modified resection is to plot this back azimuth on the map from its known location (SE 793).

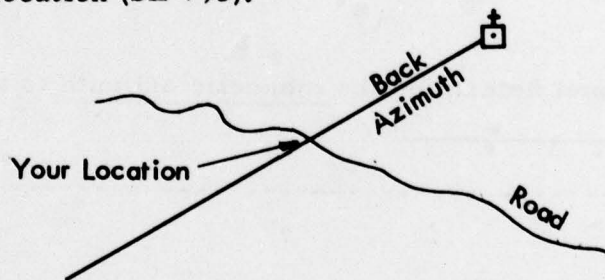

Where this back azimuth resects the linear feature on the map is your exact location.

143

In case you need more work in modified resection, here is another problem. If you feel you don't need this frame, skip to the next one.

Take out your Tenino Map, MR-6.

You are on the south bank of the Skookumchuck River running through EG 1283, EG 1383, EG 1483, EG 1583. The magnetic azimuth from your position to SE 933 in grid square EG 1287 is 328° . What is your location to within 10 meters?

EG 13318366

144

Now if you think you understand modified resection, you have completed this self instructional text on the Fundamentals of Map Reading.

THE END