

AD-A074 297

LITTLE (ARTHUR D) INC CAMBRIDGE MASS
SYSTEMS ANALYSIS OF METHODS FOR INSTALLING FUEL TRANSPORT SYSTEM--ETC(U)
JUN 79 D B ROSENFELD, R H BODE, H H LOEFFLER DAAK70-77-D-0024

F/G 15/5

UNCLASSIFIED

ADL-80260-19

NL

1 OF 2

AD
A074297



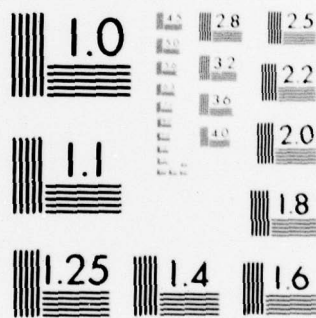

MICROCOPY RESOLUTION TEST CHART
 NATIONAL BUREAU OF STANDARDS-1963-A

LEVEL

6

Systems Analysis Of Methods For Installing Fuel Transport Systems

AD A 074297

DDIC
RECEIVED
SEP 19 1979
C

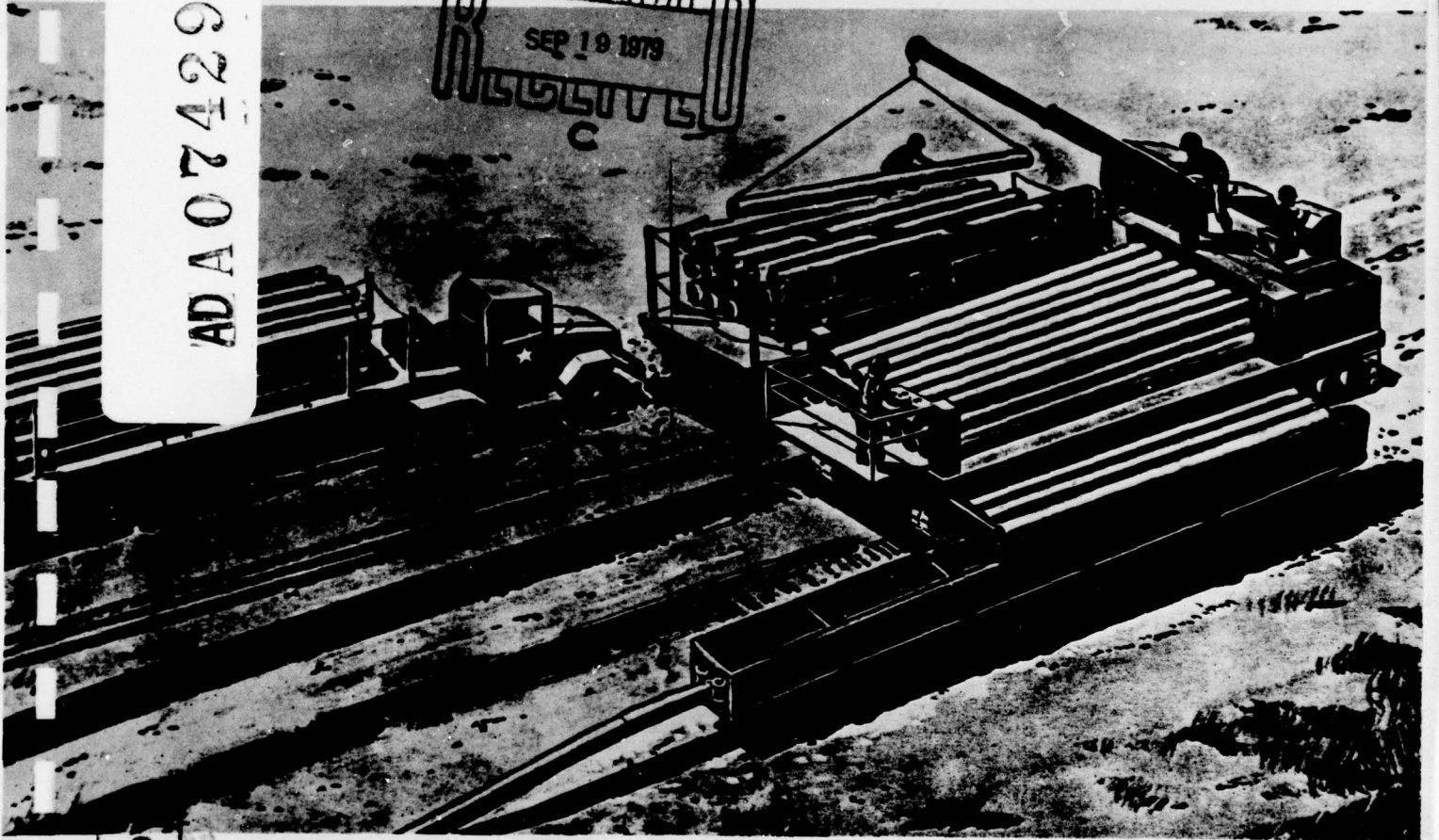

DDC FILE COP

This document has been approved
for public release and sale; its
distribution is unlimited.

JUNE 30, 1979

Arthur D Little, Inc.
U.S. Army Mobility Equipment Research and Development Command
Fort Belvoir, Virginia 22060

79 09 19 022

14 ADL-80260-19

6

6 SYSTEMS ANALYSIS OF METHODS FOR INSTALLING FUEL TRANSPORT SYSTEMS

9 Final rept. 1 Jan-30 Jun 79,

U.S. Army Mobility Equipment Research and Development Command

10 Donald B. /Rosenfield, Robert H. /Bode,
Herbert H. /Loeffler W. Scott /Nainis

11 30 JUN 1979

12 145p.

80260-19

15 DAAK70-77-D-0024

D D C
RECEIVED
SEP 19 1979
C

This document has been approved for public release and sale; its distribution is unlimited.

Arthur D Little Inc.

Cover Drawing is Courtesy of U.S. Army

208 850

mt

DISCLAIMER

The views and conclusions contained in this document are those of the authors and should not be interpreted as necessarily representing the official policies, either expressed or implied, of the U.S. Army Mobility Equipment Research and Development Command or the U.S. Government.

FOREWORD

This document summarizes the key findings and presents the background material relevant to the study entitled "Systems Analysis of Methods for Installing Fuel Transport Systems." The report presents a systems analysis approach and evaluation of alternatives considered for installing rapidly deployable fuel transport systems for an army in the field. Such methods include mechanized pipeline construction equipment as well as other systems. The report is submitted to the U.S. Army Mobility Equipment Research and Development Command (MERADCOM) at Fort Belvoir, Virginia, by Arthur D. Little, Inc., 20 Acorn Park, Cambridge, Massachusetts 02140, and was prepared under Task Order No. 10 of Contract No. DAAK70-77-D-0024. This report was prepared under the guidance of Mr. Leon Medler and Mr. Wayne Studebaker of MERADCOM. Questions of a technical nature should be addressed to Dr. Donald B. Rosenfield at 617-864-5770, the manager of the study and principal investigator. Other contributors included Mr. Robert H. Bode, Dr. Roger P. Caron, Mr. Robert Eiler, Mr. William P. Hidden, Mr. Thomas P. Howard, Mr. Herbert H. Loeffler, Dr. W. Scott Nainis, and Dr. Gordon Raisbeck.

Accession For		<input checked="" type="checkbox"/> <input type="checkbox"/> <input type="checkbox"/>
NTIS GRA&I		
DDC TAB		
Unannounced Justification		
By _____		
Distribution/		
Availability Codes		
Dist	Avail and/or special	
A		

TABLE OF CONTENTS

	Page
Foreword	i
Table of Contents	ii-iii
List of Tables	iv
List of Figures	v
Executive Summary	vi-ix
Chapter 1 - Introduction, Background and Study Organization	1
1.1 Introduction	1
1.2 Background	2
1.3 Study Organization	5
Chapter 2 - Systems Analysis Methodology	8
2.1 General Methodology	8
2.2 Scoring Methodology	10
2.3 Identification of Attributes	11
Chapter 3 - Description of Alternative Pipeline Systems	17
3.1 Introduction	17
3.2 Description of Alternative System Concepts	22
Chapter 4 - First Phase Evaluation	32
4.1 Introduction	32
4.2 Consolidation of System Attributes	33
4.3 Scoring System	35
4.4 Scores	41
4.5 Conclusions and Plan for Phase II	43
Chapter 5 - Mission Definition for Comparative Evaluation of Selected Concepts	45
5.1 Introduction	45
5.2 Mission Definition	46

TABLE OF CONTENTS (CONTINUED)

	Page
Chapter 6 - Economic Analysis of Base Case Manual System	52
6.1 Description of System	52
6.2 Life Cycle Cost	55
Chapter 7 - Economic Analysis of Truck Haulage System	67
7.1 Introduction	67
7.2 Life Cycle Cost Computation	68
Chapter 8 - Analysis of Forming Concept	71
8.1 Introduction	71
8.2 Feasibility Analysis	71
8.3 Conclusions and Reevaluations	74
Chapter 9 - Description and Economic Analysis of Mechanized Pipelaying System	78
9.1 Description of System	78
9.2 Life Cycle Cost Analysis for Fork Lift Option	93
Chapter 10 - Description and Economic Analysis of Collapsible Hose Concept	100
10.1 Introduction	100
10.2 Use and Development of Hose System	100
10.3 Life Cycle Cost	103
Chapter 11 - Second Phase Evaluation and Recommendations	111
11.1 Introduction	111
11.2 Steps in Analysis	112
11.3 An Overall Utility Measurement	125
11.4 Conclusions and Recommendations	128
Appendix 1 - References and Sources	A-1

LIST OF TABLES

	Page
Table 1 - Life Cycle Cost and Attribute Trade-off Table for Final Evaluation	viii
Table 4-1 Relative Scores	36-39
Table 4-2 Scoring Transformations	40
Table 6-1 Manual Pipeline Laying Rates	52
Table 6-2 Crews Required to Lay Pipeline at 30 KM/Day and Maximum Crews Available for Pipelaying Per Petroleum Pipeline and Terminal Operating Company	53
Table 6-3 Petroleum Pipeline and Terminal Operating Company Pipeline Laying Rate	53
Table 6-4 Number of Petroleum Pipeline and Terminal Operating Companies Required to Lay a Pipeline at 30 KM/Day Rate	54
Table 6-5 20-Hour Days Required to Lay Pipeline Mission Equipment	54
Table 6-6 Summary of 20-Hour Days Required to Lay Pipeline with Maximum Manpower Efficiency	61
Table 6-7 Unit and Trailer Loads	62
Table 6-8 Trailer Trips Required	62
Table 6-9 Tractor-Trailer Hours	63
Table 8-1 Revised Phase 1 Scores for Alternative F3e	76
Table 9-1 Tractor-Trailer Requirements for Hauling Pipe	98
Table 9-2 Tractor-Trailer Requirements for Hauling Pumping Stations	98
Table 10-1 Tractor-Trailer Requirements	108
Table 10-2 Tractor-Trailer Requirements	108
Table 11-1 Consolidated Attribute Ratings for Pipeline Alternatives	114
Table 11-2 Alternative Pipeline Systems - Life Cycle Cost Summary	121
Table 11-3 Combined Reliability and Performance Measures Using Various Weighting Systems for the Alternative Pipeline Systems	123
Table 11-4 Life Cycle Cost and Attribute Trade-Off Table - For Final Alternatives	126
Table 11-5 Totally Weighted and Scored Analysis	128

LIST OF FIGURES

	Page
Figure 1-1 Rapid Pipeline Construction	3
Figure 1-2 Simple Mechanized System	4
Figure 1-3 Logical Flow of Study	7
Figure 2-1 Overall Systems Analysis Procedure	9
Figure 2-2 Phase I Scoring Approach Phase II Evaluation and Scoring Approach	12
Figure 5-1 Typical R&D Program	47
Figure 8-1 Hypothetical Forming Machine	77
Figure 9-1 Pipelaying Machine Self Contained Reload Cranes Concept Drawing	80
Figure 9-2 Pipelaying Machine Forklift Truck Reload System Concept Drawing	81
Figure 9-3 Typical Fork Lifts	82-83
Figure 9-4 Coupling Concept No. 1	86
Figure 9-5 Coupling Concept No. 2	88
Figure 9-6 Coupling Concept No. 3	90
Figure 9-7 Coupling Concept No. 4	92
Figure 10-1 Time Requirements for Flexible Pipeline R&D Program	102
Figure 11-1 Rating Score Function for Transport Ton Requirements	116
Figure 11-2 Rating Score Function for Installation Truck-Mile Requirements	117
Figure 11-3 Rating Score Function for Installation Manpower Requirements	118
Figure 11-4 Rating Score Function Proposed for Total Life Cycle Cost	127

EXECUTIVE SUMMARY

The United States Army has identified a requirement for fuel pipeline systems that can be rapidly laid in tactical situations. The U.S. Army Mobility Equipment Research and Development Command (MERADCOM) commissioned this study to determine the most promising approaches for developing such systems.

The Army's goal is to lay 30 kilometers of pipeline per day, but the number of men now needed to lay pipeline at that rate is unacceptable. Approaches that overcome this and other problems of today's system were sought. An example of a potential solution if it met technical requirements is a machine to mechanize the pipelaying operation. The study was not, however, restricted to pipelines as such. Several different types of fuel transport systems were considered, and one of the most promising systems analyzed was a flexible hose system.

The approach followed in the study was a systems analysis and comprehensive evaluation of all alternatives we were able to conceive. The study was performed in the following steps:

- All systems that we could conceive of for the installation of fuel transport systems were tabulated.
- All system attributes that we judged to have bearing on the system utilities were listed and described. More than 30 attributes incorporating cost, performance, resource requirements, and development risks were included.
- A two-phased scoring system (the second phase being more detailed) was devised to relate the value and importance of each attribute to a common goal.
- Competing systems were evaluated according to the scoring system. The initial evaluation was made first to reduce the number of candidate alternatives without eliminating any of the best. The remaining alternatives were evaluated at an increased level of detail in the second phase of the study.

The first phase of the evaluation resulted in the following five candidate systems:

- The base system-- the currently manually coupled pipeline system.
- Truck haulage system utilizing standard Army tractors and bulk tank trailers.
- New pipeline concept--system for laying continuously formed and seamed tubing from steel strip.
- New pipeline concept-- system of mechanized coupling and laying of joints and couplings.
- New concept -- system of laying long sections of collapsible hose from large containers.

In the second phase of the study, a life cycle cost analysis based upon a common mission was performed for four of the five systems. For the continuous tube forming system, additional research showed that the system was not feasible for the given mission. The life cycle cost analysis aggregated all cost attributes to a common basis. The other non-cost attributes were also aggregated into three additional rating factors. Thus, the final evaluation was based on numerical ratings for the following four attributes.

- Life cycle cost with and without deployment
- Development risk
- System resource requirements for fuel transport system installation
- Performance and reliability of operating system

The final evaluation of the attributes is presented in Table 1. In the table, the life cycle cost figures are presented in millions of dollars for each 119-mile long system, and the other attributes are rated on a scale from zero to four, where zero represents highly undesirable and 4 represents excellent. Based on the evaluation in this table, we reached the following conclusions:

1. Both the truck haulage system and the present manual system can be eliminated because of poor ratings in one of the major areas. In truck systems, the cost is too high. This system is, however, an excellent performer and involves no installation and might be useful as a backup system under certain conditions. The present manual system requires too much manpower for a rapid installation. This is reflected in the poor rating for systems resource requirements in installation.

TABLE 1

LIFE CYCLE COST AND ATTRIBUTE TRADE-OFF TABLE FOR FINAL ALTERNATIVES

	<u>Total Life Cycle Cost+</u>	<u>Cost Without Deployment+</u>	<u>Development Risk</u>	<u>Resource Requirements Index</u>	<u>Performance and Reliability Index</u>
Baseline	23.5	18.7	3.9	.5	4
Mechanized	28.5	23.1	2.8	2.6	3.5
Hose	20.7	17.1	1.7	4	2.5
Tanker	50.4	33.8	3.9	4.7*	2.5

Scoring Key: 4 = Excellent
 3 = Good
 2 = Fair
 1 = Poor
 0 = Highly Undesirable

+ Millions of Dollars

* Score in excess of 4 denotes that the tank truck system has no system resource requirements for installation.

2. The two systems that offer promise as future developments are the hose system and the mechanized pipelaying system. The actual choice between the two involves a utility trade-off among the final four attributes. The hose system is less expensive and facilitates laying. On the other hand, it involves more development risk and rates a little lower in performance and reliability (although the performance and reliability are adequate for the mission). Various mathematical systems for rating the overall utility can be utilized. However, under most decision-maker preferences, the hose system should be the first choice. In particular, a decision-maker with low or moderate risk aversion should choose the hose system. In this situation, performance shortcomings appear to be relatively small and are overcome by costs and system resource requirements advantages.

In a practical sense, the hose system is most appropriate for the application. It is a rapid installation system and although the working life is shorter and reliability is a little lower, tactical pipelines are not meant to be long lasting, highly reliable systems.

We wish to emphasize that both systems merit further consideration. Both systems involve some development risk. The hose system requires the development of a medium pressure 300 psi flexible, collapsible hose. American Biltrite believes that such a hose can be developed and is considering an internal development program for 300 psi fire hose. The pipelaying system requires the development of a highly mechanized laying system and a new coupling for automatic machine joining of the joints. The short-term recommendation is to direct the initial research and development program to the hose concept.

CHAPTER 1 - INTRODUCTION, BACKGROUND AND STUDY ORGANIZATION

1.1 INTRODUCTION

This systems analysis of methods of installing fuel transport systems was undertaken under the auspices of the Systems Analysis Division of the Program and Analysis Directorate of MERADCOM on behalf of the Petroleum and Environmental Technology Division of the Energy and Water Resources Laboratory. The points of contact for the study were Mr. Wayne E. Studebaker for technical guidance, and Mr. Leon Medler for contracting guidance under the direction of Mr. Jerry Dean.

The original objective of the study was to identify and evaluate pipeline construction, equipment and system concepts that would enhance the rate of petroleum pipeline construction and reduce personnel requirements during rapid construction. The study required the performance of the following activities in support of the above objective:

- Analyze current military and commercial pipeline construction practices in order to identify problem areas including constraints on rates of construction and labor intensive operations.
- Synthesize potential solutions to problems considering automation/mechanization of the various aspects of pipeline construction.
- Formulate systems concepts providing the capability to rapidly construct petroleum pipelines with minimal personnel.
- Conduct trade-off analyses to determine the optimum system configuration for each alternative concept.
- Compare alternative system concepts on the basis of cost and operational effectiveness.
- Identify the rapid pipeline construction equipment system concept(s) possessing sufficient military worth to merit further development.

- Identify areas of technical risk which need to be resolved prior to entry into system development.

MERADCOM has been considering such concepts for the past several years. An artists conception of an automated system is presented in Figure 1-1. A simple mechanized system is presented in Figure 1-2.

At the initial organization meeting at MERADCOM on January 15, 1979 the scope of work was broadened to include all potential petroleum handling systems to assure that the universe of alternative petroleum handling and delivery systems have been documented and evaluated by an objective, qualitative and quantitative systems analysis.

1.2 BACKGROUND

The current military petroleum pipeline system uses 20' sections of 8" and 6" lightweight steel tubing with reinforced grooved ends. The pipe couplings consist of a self-sealing gasket and a split housing that makes a bolted connection. The principal problem with this pipeline system is the time required and the labor intensity of manually laying the pipeline. Nine men are required to lay one section of 8" pipe and make one joint in 4.5 minutes, and seven men are required to lay one section of 6" pipe and make one joint in 4 minutes. The present mission requirement is to lay 85 miles of 8" pipeline and two 17-mile divergent legs of 6" pipeline in five 20-hour days. The present manual method of laying requires six Quartermaster Petroleum Pipeline and Terminal Operating Companies of 181 men each, of whom 122 are available to work on the pipeline and the others are in support. The objective of MERADCOM is to provide the Army with the system capabilities of laying a pipeline or its equivalent in five days with one company of approximately 181 members.

The USSR has a mechanized capability of laying a military petroleum pipeline. The following brief description of the Soviet Mobile Pipelaying Machine was given by a source document.

PIPE

Diameter - 150 mm
Length - 6-7 Meters
Material - Steel
Coupling - Rubber lined female pressure fitting

PIPE HANDLING

Initial Description

- 80 sections per truck load, 8 layers of 10.
- Transfer from truck to pipelayer 10 sections, one layer at a time by crane mounted on pipelayer.

FIGURE 1-1
(U.S. Army Photograph)

RAPID PIPELINE CONSTRUCTION



FIGURE 1-2
SIMPLE MECHANIZED SYSTEM
(U.S. Army Photograph)

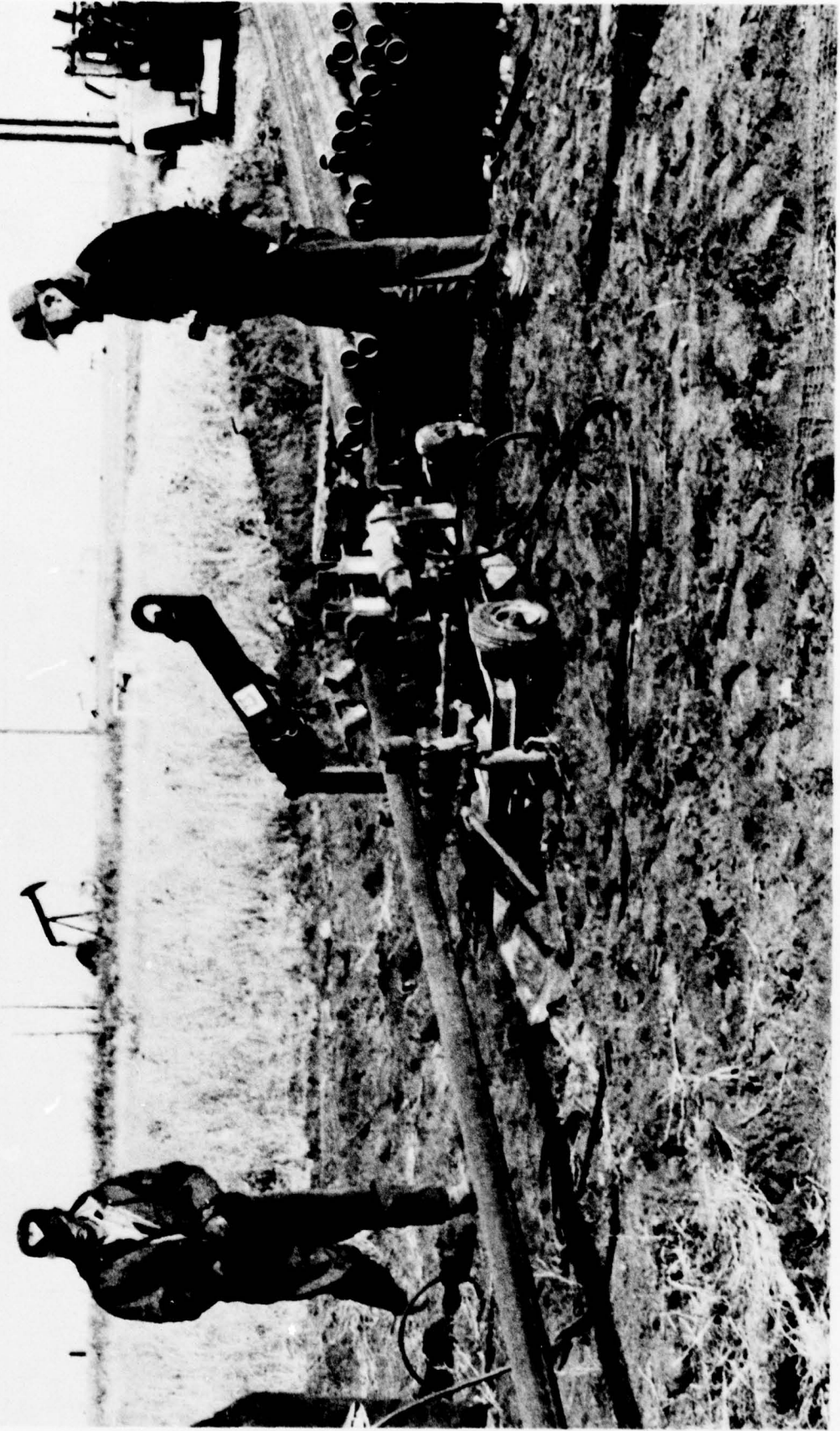

Latest Description

- Truck carries pallet of 40 sections.
- Transfer pallet with 40 sections of pipe as unit from truck to pipelayer with crane mounted on pipelayer.

PIPELAYER

- Three-axle semi-trailer towed by crawler or wheel mounted tractor with 5th wheel.
- Pipe coupled while machine is moving
- Operator controls joining operation
- Pipe "forced sharply rearward" for joining
- 2 or 3 laborers walk beside machine to remove rocks and cut brush in pipe path and to assist when machine malfunctions.

1.3 STUDY ORGANIZATION

The results of this study are organized under the following topics, each of which is presented in a separate chapter. The logical flow of the various chapters parallels the various steps utilized in the study. Figure 1-3 presents the logical flow of the study. Chapter 2 introduces the systems analysis methodology, while Chapter 3 introduces the engineering concepts. Chapters 4 and 5 lead into the five chapters on the selected concepts for Phase II evaluation, and Chapter 11 consolidates the results of Chapters 5 through 10.

Chapter 1 - Introduction, Background and Study Organization

Chapter 2 - Systems Analysis Methodology

Chapter 2 presents the attributes of tactical fuel delivery systems that have bearing on their usefulness and a systems analysis approach to evaluate alternatives with such multiple attributes. The chapter presents the methodology by which the remaining analyses are performed.

Chapter 3 - Description of Alternative Pipeline Systems

This chapter presents descriptions of the various systems considered for installing pipeline or other fuel delivery systems.

Chapter 4 - First Phase Evaluation

This chapter presents the systems evaluation of the various alternatives. Five systems alternatives were selected for more detailed evaluation in the second phase.

Chapter 5 - Mission Definition for Comparative Evaluation of Selected Concepts

In the second phase of the evaluation procedure, a common pipeline mission is defined by which life cycle cost is computed. Life cycle cost is one of

the major (but not the sole) ratings determinants in the second phase evaluation.

Chapter 6 - Economic Analysis of Base Case Manual System

This chapter presents the life cycle cost computations for the basecase manual pipelaying system, which is the present system utilized by the Army.

Chapter 7 - Economic Analysis of Truck Haulage System

This chapter presents the life cycle cost computations for the system that utilizes tanker trucks for fuel delivery.

Chapter 8 - Analysis of Forming Concept

This chapter presents a description and analysis of the forming concept. In the second phase evaluation, it was determined that a forming machine would be larger and more costly and less reliable than originally envisioned. Development risk was judged to be very high. In view of this, the life cycle cost of the forming concept was not analyzed.

Chapter 9 - Description and Economic Analysis of Mechanized Pipelaying System

This chapter presents a description and a life cycle cost analysis of the mechanized pipelaying system. In implementing the mechanized pipelaying system, future engineering development is required. The description of the system presents several joint and pipelaying concepts.

Chapter 10 - Description and Economic Analysis of Collapsible Hose Concept

This chapter presents the description and life cycle cost analysis of the flexible, collapsible hose concept. This concept requires significant development and the Chapter presents the issues involved in the development.

Chapter 11 - Second Phase Evaluation and Recommendations

This chapter presents the evaluation of the surviving alternatives and our final recommendations. The evaluation methodology, which reduces system characteristics to four final measures, is also explained here.

FIGURE 1-3
LOGICAL FLOW OF STUDY

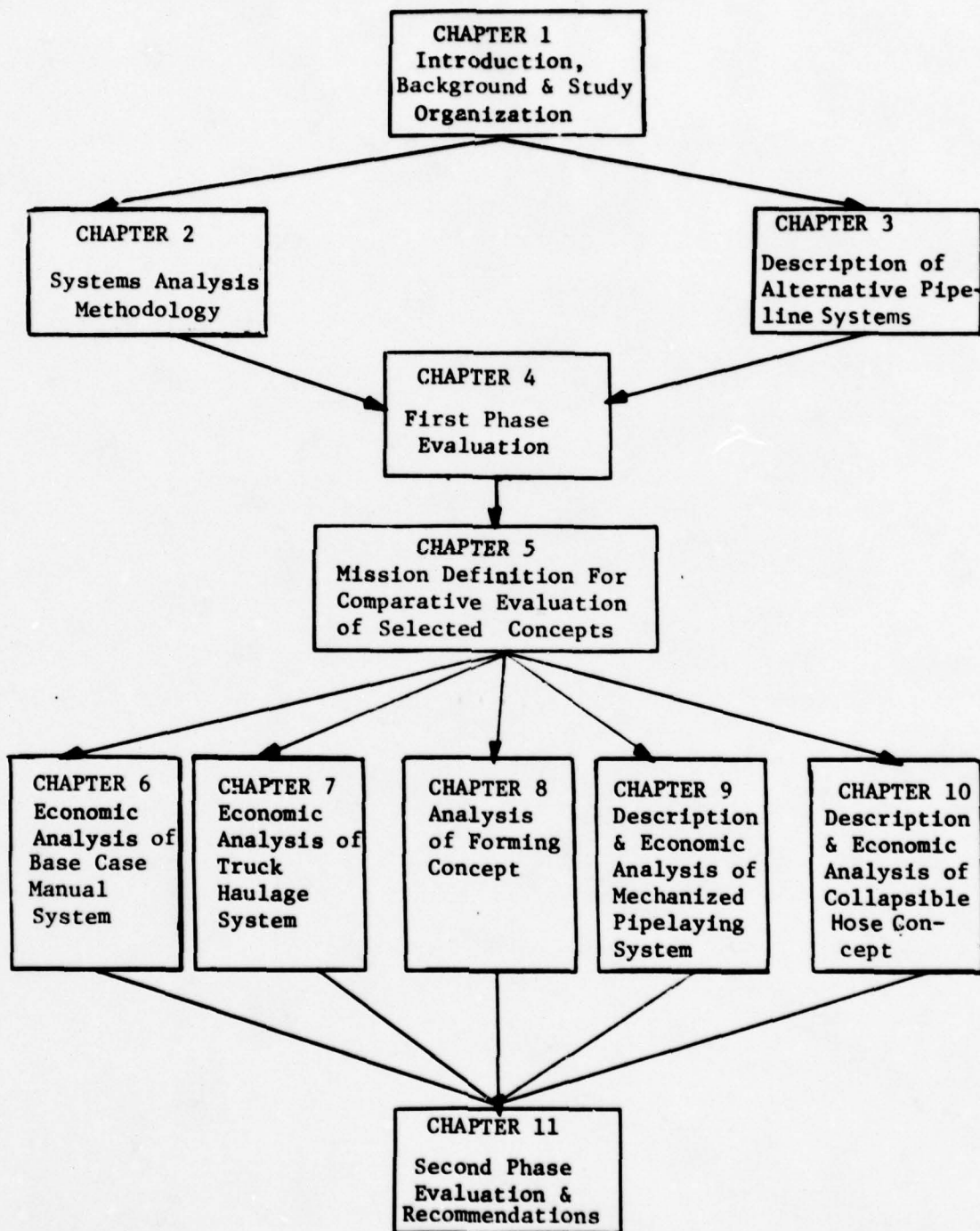

CHAPTER 2 - SYSTEMS ANALYSIS METHODOLOGY

2.1 GENERAL METHODOLOGY

The overall method of identifying concepts most appropriate for the fuel transport systems was a systems analysis approach consisting of two major steps:

- Identification of alternative systems concepts
- Systems evaluation of the alternative concepts in terms of the systems attributes.

The actual process was somewhat more involved in that first, the attributes appropriate for systems evaluation had to be identified, and second, the evaluation procedure was an iterative one involving two phases. A flow-chart for the overall procedure is depicted in Figure 2-1.

In identifying system attributes, those characteristics of the systems we believed might be useful in evaluation were tabulated and categorized. These attributes spanned the range of cost and performance characteristics. After each evaluation, attributes were refined by aggregation and in some cases, elimination. Attributes were eliminated if there were no discernable differences with respect to that attribute among the remaining system concepts. An example of this was ease of leak detection. None of the identified system concepts appeared to show any advantages with respect to ease of leak detection. Groups of two or more related attributes were aggregated when their scores were highly correlated.

Evaluation of systems attributes was performed in several ways. One mentioned was a qualitative evaluation that compares the relative merits of competing systems. As an example, a relative scale of 0 to 4 was frequently utilized where 4 represented the best relative score for a particular attribute and 0 represented the lowest relative score. Another method was the comparison of actual numerical value for certain attributes. As an example, in the final phase of evaluation, life cycle cost in estimated dollars was utilized as a basis for comparison.

The most desirable method of analysis would have been evaluation of all attributes for each system candidate in complete detail. However, the cost and time constraints on this study precluded such an approach and the methodology utilized was an iterative evaluation procedure. In the first phase, all attributes were evaluated qualitatively, using

FIGURE 2-1

OVERALL SYSTEMS ANALYSIS PROCEDURE

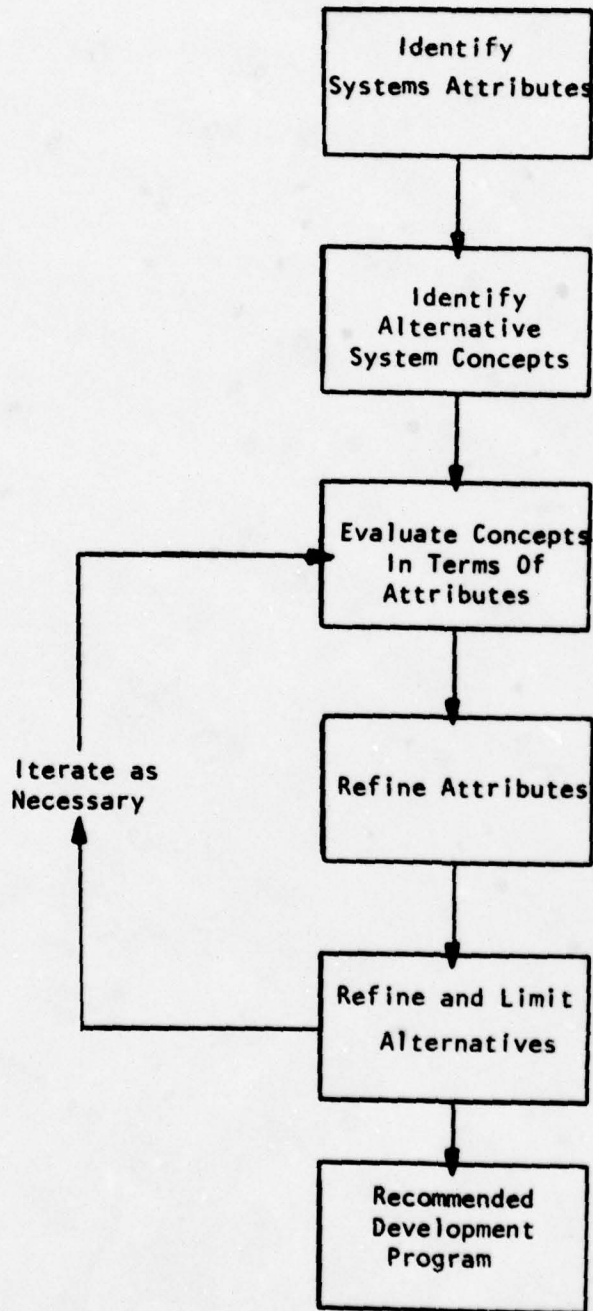

relative scales, to eliminate alternatives that were clearly less desirable than others. In the second phase, when only a limited number of concepts were being evaluated, more detailed quantitative measures of the attributes were used. Where more precise measures could not be applied or failed to discriminate between systems, the detail in the systems descriptions was enriched to provide additional scoring criteria.

The actual overall evaluation in each of the iterative steps consisted of

- a. A qualitative or quantitative evaluation of each attribute for each system or system component.
- b. A scoring or trade-off analysis to evaluate each system overall subject to the multi-attribute scores.

The scoring involved the weighting of each attribute score for an overall system score. In the final phase of evaluation, however, a somewhat modified method of system trade-off was utilized. The detailed methodologies for system scoring and evaluation are described in the first and second phase evaluations in Chapters 4, 5 and 11.

2.2 SCORING METHODOLOGY

In order to develop an overall ranking of the alternative pipeline concepts, it was necessary to combine ratings of individual system attributes and effectively weigh them together in order to produce an overall total score for each concept. A complicating factor was the fact that the relative importance of an attribute does not stay fixed over the entire range of the attribute value. For example, a particular attribute level may saturate in the sense that more, or a better level of the attribute may not provide any perceivable advantage. On the other hand, as an attribute level falls toward the unacceptable range, the positive contribution to the overall score should be reduced drastically. For this reason, we utilized a non-linear scale for relating the overall score to each attribute score.

The other key aspect was an additive approach relating total scores to the contribution from each attribute.

Formally, let

- A_i = quantitative attribute level where available
- X_i = qualitative attribute score (between 0 and 4.0)
- i = system (concept) index
- $W_i(X_i)$ = score weight function associated with score level X_i
- N = number of attributes

where

$$X_i = X_i(A_i) = \text{qualitative attribute scoring function} \quad (1)$$

converts a quantitative score to a 0 to 4 relative score. (See, for example, Figure 11-2).

The overall system score would be:

$$W_{TOT} = \sum_{i=1}^N W_i(X_i) = \sum_{i=1}^N W_i(X_i(A_i)) \quad (2)$$

In Phase II major attribute evaluations were developed by finding a set of major attribute weightings:

$$W_{MAJOR_k} = \sum_{i \in N_k} W_i(X_i) \quad (3)$$

Where

N_k = set of all attributes associated with major performance index K.

In general the weighting function may not be additive and equation (3) becomes

$$W_{MAJOR_k} = W_{MAJOR_k}(X_i; i \in N_k) \quad (4)$$

The two-phase approach is depicted in Figure 2-2.

2.3 IDENTIFICATION OF ATTRIBUTES

In order to evaluate each of the concept systems, a list of system attributes were developed. In each of the evaluation phases, the attribute list was reduced to some extent to reflect possible aggregation and eliminations (the latter when there was little or no variations among systems). These are discussed in the sections on first and second phase evaluations. The attribute list in this chapter represents a complete list of system characteristics judged by us to be important to MERADCOM, without regard to relative importance, overlap, discriminatory ability, or level of appropriate detail. Therefore, all of the following were considered, but possibly not utilized in later evaluations. Subsequently, in the first phase evaluation, the list was modified and reduced.

FIGURE 2-2

Phase I - Scoring Approach

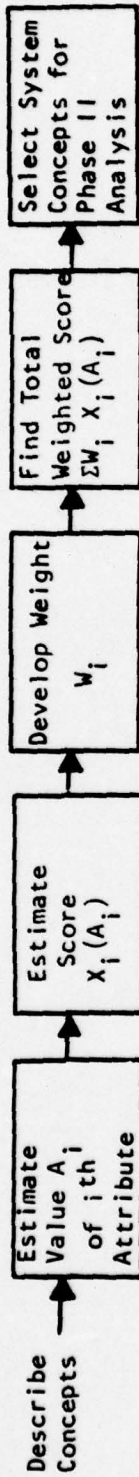

Phase II - Evaluation and Scoring Approach

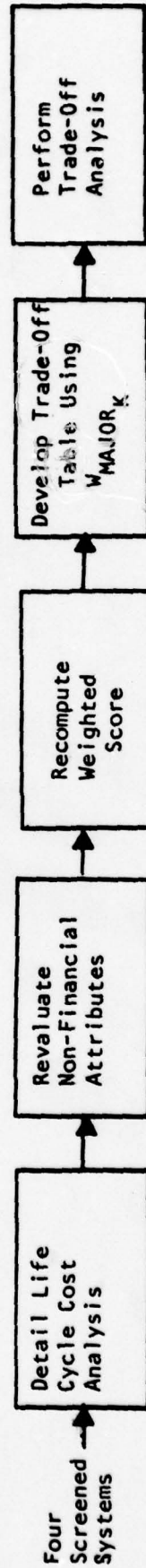

The major attribute categories for the pipeline system include the five following areas:

- System Performance
- System Reliability and Risk
- System Cost
- System Resource Requirements
- System Vulnerability

There is an overlap among the five above areas. For example, system costs and resource requirements are directly related; likewise some aspects of reliability are parallel to system performance. Separating the attributes into groups and using finer breakdowns of the attributes allows attribute scoring and weighting exercises to distinguish among disparate pipeline design concepts.

In order to compare two pipeline concepts on a relevant basis the concepts must be developed so that they both target the same major performance goals. In this case the major performance goal is a design installation rate of 20 miles/day of installed pipeline to a total length of over 100 miles and having a capacity of 35,000 bbl/day. These performance attributes should be generally similar among candidate designs; the major variation is expressed in the other important attributes such as reliability and costs.

System Performance Attributes

- P.1 Average pipeline laying rate (miles/day)
 - a. Under fully equipped or "automated" conditions
 - b. Under "nonautomatic" or backup conditions
- P.2 Pipeline capacity (bbl/day)
- P.3 Degradation of pipeline laying rate when facing rough terrain
- P.4 Effects of ambient temperature on
 - a. Operation
 - b. Installation
 - c. Maintenance and repair
- P.5 System performance over time, i.e., operational lifetime
- P.6 System component storage shelf life
- P.7 Expected concept development time (years) by major component
 - a. Pipeline
 - b. Installation/connection equipment
 - c. Other transport equipment

¹ 85 miles of 8" pipe and 34 miles of 6" pipe to an actual total length of 119 miles.

System Reliability and Risk Attributes

- R.1 In-field likelihood of meeting major performance specifications
 - a. Pipeline laying rate
 - b. Pipeline capacity
- R.2 Pipeline availability (% of time demanded) with a given maintenance program
- R.3 Percentage leakage after initial installation and inspection program
- R.4 Development Risk
 - a. Risk of higher than expected development cost
 - b. Risk of lower than expected major performance level in design
 - c. Risk of longer than expected development time
- R.5 Risk of unforeseen problem in development and deployment
 - a. Pipeline
 - b. Installation equipment
 - c. Other transport equipment
- R.6 Safety for Personnel
 - a. Installation
 - b. Operation
- R.7 Susceptibility to in-transit damage
 - a. Likelihood of a leak (% probability per unit length)
 - b. Likelihood of material waste (% material)

System Cost Attributes

- C.1 Cost of component development (10^6 \$)
 - a. Pipeline material
 - b. Fabrication/installation/assembly equipment
 - c. Other transport equipment
- C.2 Cost of component acquisition (\$/unit or \$/unit length)
 - a. Pipeline material
 - b. Fabrication/installation assembly equipment
 - c. Other transport equipment

- C.3 Cost of pipeline material storage handling and transport to supply depot
- C.4 Pipeline fabrication/installation/assembly costs (\$/unit length)
- C.5 Average pipeline transport cost from supply depot into position (\$/unit length)
- C.6 Pipeline operating costs (\$/bbl-mile)
- C.7 Pipeline maintenance and repair costs (\$/bbl-mile)
- C.8 Life cycle cost (\$/bbl-mile)

System Resource Requirements Attributes

RR.1 Manpower requirements (hours/mile or hours/bbl-mile)

- a. Installation
 - 1. Unskilled
 - 2. Semi-skilled
 - 3. Specialized
- b. Operation
 - 1. Unskilled
 - 2. Semi-skilled
 - 3. Specialized

RR.2 Equipment requirements

- a. Special to theater transport
- b. Trucks
- c. Fabrication/installation/assembly equipment
- d. Other machinery

RR.3 Reliance on scarce or limited supplier materials

RR.4 In-field energy requirements

- a. Installation
- b. Operation
- c. Maintenance and repair

System Vulnerability Attributes

- V.1 Relative ease of sabotage destruction to pipeline
- V.2 Dependence on vulnerable equipment for installation and repair
- V.3 Relative ability to divert and tap
 - a. Ease of tapping
 - b. Ability to detect
- V.4 Ease of sabotage repair

The goal in developing the attribute list was the consideration of all possible factors in rating competing systems. At each evaluation stage, attributes were refined to a degree commensurate with the evaluation. In the first stage of evaluation the goal was to rank the competing systems with respect to the above list of attributes. Attributes were aggregated when highly correlated attributes could not be evaluated at a high level of detail. This procedure is described in Chapter 4.

CHAPTER 3 - DESCRIPTION OF ALTERNATIVE PIPELINE SYSTEMS

3.1 INTRODUCTION

In order to determine the best overall solution to meeting the performance and cost requirements it was decided to review the full range of all conceivable technical approaches to a pipeline system development. In this chapter the major approach categories are listed and discussed separately. Once the number of pipeline system candidates was reduced to five (later, one of the five - a forming process - was eliminated, leaving only four) it was possible to investigate the alternatives in more detail. Many of the initial assumptions on performance and function were changed during the second phase study.

1. Major Alternative Categories

The major concept categories included:

H - Hose	All forms of flexible hose, collapsible and non-collapsible
C - Continuous	All forms of conduit generation from extrusion of metal and plastic materials.
F - Forming	All forms of generating conduit from rolled flat stock of metal and plastic materials
S - Sectioned Pipe	All forms of sectioned rigid and semi-rigid conduit of metal or plastic materials coupled together during installation.
N - Non-Pipe	All methods of non-pipeline transport of fuel using such approaches as conveyor belts, ballistic projection, tanker trucks, etc.

Essentially all conceivable systems fall into the above classes. Many variations of approach (both major and minor variations) exist within each major concept category. The purpose in the Phase I evaluation and screening was to eliminate the obviously inferior concepts and focus upon a few more promising alternatives.

2. Phase I Enumerated List of Concepts

A large number of different concept alternatives were proposed. Each of these concepts which is listed below meets the major pipeline performance specifications (i.e., laying rate of 20 miles per 20-hour day and an average throughput capacity of 35,000 barrels per day.) Each concept is thought to comprise a system that encompassed all components which are required to meet all of the performance specifications. Thus, for example, a flexible hose concept requires, in addition to the hose itself, the trucks and machinery required to handle transport and lay spools of hose. In listing the various alternatives a labelling code has been devised which breaks the concepts into major categories and allows minor variations among concepts to be distinguished.

The pipeline systems listed comprise a list of alternative systems developed upon initial investigation on the general mission requirements. The technical discussion of these alternative concepts forms the basis for the Phase I evaluation.

The sources of evaluative information of these alternative concepts included in-house knowledge of engineering capabilities and performance of various pipeline systems and components, information furnished by MERADCOM in the form of reports, and informal discussions and information collected from appropriate equipment vendors contacted and queried during Phase I of the study.

The detailed set of alternatives used for evaluation include:

Hose

- H1 Flexible, non-collapsible, low pressure rolled hose, 8' diameter spool dimension
- H2 Flexible, non-collapsible, medium-high pressure rolled hose, 8' diameter spool dimension
- H3 Flexible, collapsible, low-medium pressure rolled hose, 8' diameter spool dimension
- H4 Flexible, collapsible, reinforced, high pressure rolled hose, 8" diameter spool dimension
- H5 Flexible, collapsible, glass reinforced "B" stage thermoset rolled hose.

Continuous

- C1 Extruded aluminum, high pressure, continuous pipeline manufacture
- C2 Extruded plastic, unreinforced, low pressure, continuous pipeline manufacture
- C3 Extruded plastic, reinforced, medium-high pressure, continuous pipeline manufacture. (This alternative encompasses formed rings and ribs, filament wound, braided fibers of glass or metal, chopped fibers in melt extrusion with mat.)
- C4 Drawn steel, continuous pipeline manufacture
- C5 Drawn aluminum, continuous pipeline manufacture
- C6 Flow-turned steel, continuous pipeline manufacture
- C7 Flow-turned aluminum, continuous pipeline manufacture
- C8 Continuously cast steel pipeline manufacture
- C9 Continuously cast aluminum pipeline manufacture
- C10 Continuously cast plastic thermoset, unreinforced, low pressure pipeline manufacture
- C11 Continuously cast, plastic thermoset, reinforced medium-high pressure pipeline manufacture

Forming

- F1 Roll formed cylinder from coiled flat strip, plastic. (This alternative encompasses a bonded seam, a locking strip seam and a lock bend seam and thermoseal.)
- F2 Formed pipeline from coiled flat strip, steel. Several sub-alternatives include:
 - a. Welded seam
 - b. Molecular bonded seam
 - c. Riveted seam and film liner
 - d. Overlap and adhesive seam
 - e. Lock bend seam and thermoset seal
 - f. Lock bend seam and film liner
 - g. Locking strip seam

F3 Formed pipeline from coiled flat strip, aluminum.
Some subalternatives include:

- a. Welded seam
- b. Molecular bonded seam
- c. Riveted seam and film liner
- d. Overlap and adhesive seam
- e. Lock bend and thermoset seal seam
- f. Locking strip seam

F4 Formed pipeline, prestressed cylinder from flat strip
(either steel or aluminum)

F5 Spiral tube formed pipeline. (This alternative encompasses parallel layers of multiple strips of metal with adhesive bond, cross winds of multiple strips with an adhesive bond, and cross winds of multiple strips of a plastic pultrusion with resin bond).

Sectioned Pipe

S1 Sectioned pipeline with mechanized pipe handling and coupling. (This alternative encompasses all types of existing couplings and either steel or aluminum. The couplings could be, for example, friction forced-fit, threaded, grooved pipe with clamp and gasket, or bell and spigot.)

S2 Sectioned pipeline with mechanized pipe handling with some type of final manual step. The types of couplings are the same as for alternative S1 and either steel or aluminum is a possibility for this alternative.

S3 Sectioned pipeline with manual handling and manual coupling with some type of guide utilizing either steel or aluminum and one of the four types of existing couplings listed under alternative S1.

S4 Sectioned pipeline with manual pipe handling and manual coupling utilizing either steel or aluminum and one of the four types of couplings noted above, but without some type of guide to be used during assembly.

S5 Arc welded sectioned pipeline, steel

S6 Arc welded sectioned pipeline, aluminum

S7 Sectioned pipeline with manual pipe handling using a clamp and gasket plastic coupling

S8 Sectioned pipeline with manual pipe handling, plastic, threaded coupling.

- S9 Sectioned pipeline with manual pipe handling, plastic, bonded coupling.
- S10 Sectioned pipeline with mechanized pipe handling and a plastic coupling.
- S11 Sectioned pipeline, mechanized pipe handling and plastic, threaded coupling
- S12 Sectioned pipeline, mechanized pipe handling, plastic, bonded coupling.
- S13 Telescoping tubing, steel
- S14 Telescoping tubing, aluminum
- S15 Telescoping tubing, plastic
- S16 Hinged tube sections, either steel, aluminum, or plastic
- S17 Sectioned pipeline with mechanized pipe handling either steel or aluminum, but with some type of coupling designed for mechanized equipment. Coupling will be a new design.

Non-Pipe

- N1 Conveyor belt system with rubber bags
- N2 Conveyor belt system with rigid containers (barrels)
- N3 Land vehicles (trucks) carrying rubber bags
- N4 Land vehicles - tanker trucks
- N5 Air transport - rubber bags
- N6 Water transport of rubber bladders
- N7 Ballistic projection of fuel in a sequential system

3. Discussion of Initial Mission Specification

Implicit in the enumeration of the approximately fifty alternative concepts was an expectation about overall system performance. The major performance goals are 1) laying rate - i.e., 20 miles per 20-hour workday; and 2) pipeline throughput capacity of 35,000 barrels per day of distillate oil during a 20-hour pumping day.

The first major performance attribute places a very high burden on the design of any pipeline system. With 20-foot pipeline sections, for example,

20 miles per day represents one joint assembly every 14 seconds. A manual, sectioned pipeline system thus requires many crews of pipeline installers working on assembly simultaneously in order to meet the installation rate requirements.

The second major performance attribute, the fuel throughput rate, has major design implications. Thus, the sectional pipeline and hose system must use 6" and 8" conduit, and 274 tanker trucks are required to transport fuel as depicted in concept N4.

The initial Phase I list of concepts was developed as an outgrowth of a systems "brainstorming" session held at Arthur D. Little early in the beginning of the project. Subsequent to this initial brainstorming session a more detailed review and description was performed on the major attribute categories prior to developing the Phase I concept rating (as discussed in Chapter 4 of this report).

3.2 DESCRIPTION OF ALTERNATIVE SYSTEM CONCEPTS

1. Hose

Hose construction can take many forms. Heavy walled, stiff (non-collapsible) hose can be designed for thousands of psi but it would not be practical for the pipeline application on a weight and cost basis.

- Non-collapsible Hose: H1 and H2

A practical hose constructed of elastomer and heavily reinforced with metal or glass fiber could conceivably be designed to operate at pressures comparable to rigid pipe. We assumed that this material could be rolled, but not flattened. This would form concepts H1 and H2. It is assumed that less development effort and risk is involved with H1. Connections between lengths and to fittings can be made with couplings similar to current practice with hose. To take best advantage of this system for laying hose rapidly, it would be logical to use the greatest lengths that can be transported with present vehicles. Originally, a 10' cube (which corresponds roughly to 10 tons) was proposed. A 10' diameter 10' long spool could hold 2000' of hose,² which could weigh up to 10 lbs/ft. It was eventually decided to reduce the spool diameter to 8'.³

² The 200 foot length of hose could exist in a series of shorter sections coupled together and then rolled (e.g., 200 foot lengths).

³ The 10' by 10' profile of the spools was considered too large for the existing transport equipment. An 8' by 8' spool dimension was later considered.

Because of lack of presently available hose with these characteristics, it was assumed that a substantial amount of development effort would be required to produce it together with attendant risk. The usual manufacturing processes for making reinforced hose involve a large number of layers and a variety of materials.

For H1 and H2 non-collapsible hose, shipping density is low, because in addition to the hollow bore of the hose, the spools have hollow centers, and the cylindrical exteriors do not pack closely. In order to investigate the resource requirements of the H1 and H2 hose systems an installation scenario was studied. To construct 100 miles of hoseline, 500 1000' lengths must be trucked from the base point to the end of the assembly point, at an average round trip of 100 miles, this equals 50,000 truck miles.⁴

$$\begin{aligned} \frac{50,000 \text{ truck miles}}{50 \text{ Hours}} &= 1000 \text{ truck miles/hour} \\ \frac{1,000 \text{ truck miles/hr}}{15 \text{ Miles/hr.}} &= 67 \text{ trucks, or } 34 \text{ trucks for a } 20 \text{ hour day} \\ \frac{50,000 \text{ miles}}{2.5 \text{ Miles}} &= 20,000 \text{ gallons fuel} \end{aligned}$$

Installation of the hoseline can be done by the delivery trucks with minimal additional equipment. When a truck arrives at the end of the installed hose, the new end is coupled on and the truck drives on, unrolling hose; at 5 mph, this can be done in 5 minutes. Multiplied over the entire hoseline, 20 truck-hours are required to lay the hose, or 1 hour per truck in the 50 hour project. Therefore, installation is accomplished without significant use of additional equipment, manpower, or fuel. Special terrain conditions can be accommodated with minimum additional effort. Maintenance would be required if damage to the hose occurs. An entire 200' hose section can be replaced in the case of major damage. Smaller sections can be replaced by installing couplings with truck mounted equipment. Punctures can be sealed with threaded plugs.

⁴ These numbers were used for preliminary estimation purposes and as such are superseded by later, more accurate estimates in the Phase II analysis.

- Collapsible Hose: H3 and H4

If the hose described in H1 and H2 can be flattened from 7" diameter down to 2" thick by 11" wide, the volume is reduced by at least one-half. On the other hand, development cost, uncertainties, and product costs are likely to be still higher than those of non-collapsible hose.⁵

Primary transport tends to be volume rather than weight-limited, so there would be a reduction in shipping cost for H3 and H4.

If transport during construction is weight-limited, then there would be no gain in reducing the volume. On the other hand, if trucks could accommodate 10 tons of hose, twice the length, or 2000', could be carried. The impact would be to reduce the number of trucks⁶ from 67 to 33 for a 10 hour day; two shifts would have this.

Manpower and fuel consumption would be reduced essentially in proportion for H3 and H4. Other factors, relating to coupling methods, maintenance and vulnerability, would remain similar to non-collapsible hose concepts.

2. Continuous

The continuous production of conduit in the field has appealing features namely in transporting the pipeline material into the field. For this reason a number of concepts were reviewed.

- Continuous Metal Processing: C1, C4, C5, C6, C7, C8, and C9

A number of processes could be used to manufacture metal tube. These include extrusion, drawing, continuous casting, flow turning, and combinations of these. Since the feed material for these processes is in its densest possible form, there is considerable appeal in shipping the raw material and manufacturing tube in very long sections in the field. The important advantage of this approach is very good shipping density, both in primary transport and during installation. The resulting tube should have excellent mechanical properties, at minimum weight per unit length.

Unfortunately, the disadvantages would probably outweigh these good features. Equipment for metal extrusion is large and massive, to the extent that it is probably not possible to make it mobile under tactical conditions. The power requirements of this

⁵ This initial assumption did not hold to be true in the Phase II analysis.

⁶ These initial assumptions for H3 and H4 were modified in the Phase II analysis for the user system.

equipment would be extremely high. Therefore, all the gains made in transporting compact raw material will be lost in transporting the fuel required to convert it into the finished product. In light of these factors, it is hardly necessary to consider in addition the problems of field maintenance and skill levels required for its successful implementation.

- Continuous Plastic Processing: C2, C3, C10 and C11

Generating plastic tubing continuously in the field is a much more feasible prospect compared to metal tubing. To achieve a structure capable of operating at reasonably high pressures, some sort of reinforcing would be required. Therefore, the problem is not only to generate plastic tube, but to introduce the reinforcing at the time of manufacture. A possible method to be considered for this application would be the continuous casting of a thermoset material containing chopped fiber. Alternatively a more promising concept would be obtained by adding the fiber in the form of cloth, braid, mat, roving, or filament wound; however, this process would be more complex to design and implement. As is the case of continuous metal tube, the plastic raw materials are compact, but because more plastic than metal is required for a given pressure rating, it is not as compact. The main advantages of a plastic extrusion process over metal processes are that the equipment can be transportable, and the energy requirements could be reasonably low. However, the shelf life of resins is limited, and the casting process is usually very temperature sensitive.

In operation, a tube generating vehicle would move along at the desired rate of 2 mph. Tank trucks of resin would accompany the tube generator, feeding its limited reservoirs by hose. When one truck ran out, the next tank truck would connect while tube is generated without interruption. At 10 lbs/ft., 10 tons would last 2000' or 12 minutes. During the operation 50 truck-hours would be needed, which is a small percentage of the transport time. As in the rolled hose concept, H1 and H2, 67 trucks would be used. Increasing the capacity to 20 tons would reduce the number of trucks to 33.

3. Forming

Like continuous conduit manufacture forming involves constructing a pipeline in the field. Unlike continuous manufacture forming only requires the shaping of the pipeline material and the production of some type of longitudinal bond. Forming methods differ in two aspects: (1) the type of material used; and (2) the method devised to produce the longitudinal seam.

- Forming Metal Stock: F2, F3, F4

Metal tube can be formed from coiled flat strip. Either aluminum or steel strip could be used. There are a variety of methods to make a sufficiently strong seam, and to seal it. The various methods of producing the longitudinal seam include combinations of metal working; use of glues and sealants; and the adoption of locking strips. The development effort of any forming system with selected seams would be high. The development would draw heavily upon similar existing technologies, however. In any case, the strip would be formed into a cylindrical shape by roll forming. Once the metal is bent into shape then the seam is built. Additional roll forming work would be required for all types of seams.

For the purposes of evaluation consider that the stock to be transported consists of 8' diameter rolls of sheet aluminum 1/8" thick and 20" wide. At 7,000 lbs. the shipping density is very high. Installation is performed by a vehicle that can carry two rolls, and forms tube at a 2 mph rate. Each roll makes one-half mile of tube, so the vehicle can run 1 mile between reloads. Accordingly, trucks of 7 ton capacity deliver 2 reels at 1 mile intervals along the 100 mile route. 100 round trips of 100 miles are required to place the rolls into the field. This results in the requirement of 10,000 truck miles. With 100 hours available, 100 truck-miles/hour can be done with seven trucks averaging 15 mph. The forming process is likely to encounter terrain conditions that are unsuitable for pipe manufacturer. In this case, the gaps would be left, to be joined later by adapters and conventional techniques. Damage repair and maintenance would utilize the same adapters and techniques.

- Forming Plastic Stock: F1

In lieu of metal (aluminum or steel) plastic sheet could be roll-formed. Forming of plastic has the advantage that it could be performed with less energy and fewer requirements for precise alignment. A bonded seam would be a workable seaming option.

The major disadvantage of plastic forming is strength. It would have to operate at a very low pressure (less than 150 psi unless the pipe was reinforced). The inclusion of reinforcing material essentially makes it equivalent in complexity to the continuous processing concepts C3.

- Spiral Tube Formed Pipeline: F5

Another alternative is to produce a pipeline that is formed by multiple, spiral-wrapped layers of metal which are bonded together with adhesive. The concept is similar to that used to make paper cardboard tubing except it would have to be implemented on much larger scale. The advantage of the spiral-wrapped tube is that it would not have a longitudinal seam and could ultimately work at higher pressures than the other forming concepts. The main drawback of the concept is complexity.

4. Sectioned Pipeline

The most obvious approach to pipeline laying is to use sectioned metal (aluminum or steel) pipeline with couplings to join the sections. Achieving the desired laying rate is a major problem with any sectioned pipeline system. Twenty miles in 20 hours allows only 14 sec./joint. At first glance, this seems like insufficient time to perform the sequence of terrain preparation, retrieving a section of pipe from storage, aligning, making the joint, and depositing it in place. One solution is to overlap the time of the functions so that the time from one completed joint to the next is much less than the sum of the times of the various operations to complete one joint.

Another solution is to run more than one pipelaying machine simultaneously and thereby allow more time per joint (i.e., using three machines allows 42 seconds/joint on average). The major disadvantages of multiple simultaneous machines are greater costs and resource requirements.

- Manual and Semi-Manual Section Pipeline Systems: S3, S4, S5, S6, S7, S8, S9

Even the slowest manual method of constructing pipeline by joining short sections can be done at the desired rate by sufficient duplication of crews and equipment. This is present practice and is only investigated as a baseline reference. A system that would be of real interest would be capable of meeting this rate with a single piece of equipment and crew (or small number e.g., three or fewer). The method as envisioned would be to rapidly take sections from storage, align them, and join them. If 20' sections are used, joints must be made every 14 seconds in a 20 hour day. Transporting sections from storage at these rates presents a major resources requirement and a design challenge.

A company of 181 men, 122 of whom are available to lay pipe, can manually lay about 5 miles of pipe per shift. At this rate it will require 5-6 companies of crews to manually lay the pipeline; this is a major disadvantage of the manual mechanized pipeline systems.

The number of truck-miles needed to transport the pipe to the assembly site is calculated by assuming that one transport truck can carry 100 8' pipeline sections.⁷ Because each section is 20' long the number of truck-loads of pipe to be transported is 264. The average round-trip travel distance per truck is 100 miles. Thus, 26,400 truck-miles are required for transporting the pipe to the assembly point. If the average truck speed is 15 mph then the required number of trucks is 18.

● Mechanized Sectioned Pipeline Systems: S1, S2, S10, S11, S12, S17

There are two required areas of development. First, for the mechanized pipeline system a joint must be developed that meets the basic requirements of reliability and also lends itself to mechanized assembly. Then a method of section storage, feeding, and assembly must be fitted into a vehicle. The development effort will be in proportion to the degree of mechanization. These can range from manual systems with alignment fixtures through powered systems with manual control, all the way to full automation.

The components will consist of sections of aluminum, steel, or plastic tubes. The ends will be adapted with attached or separate couplings. In this form, the material is of moderate cost, consisting of raw material with value added by machining and assembly. Shelf life should be long with moderate care in storage.

The sections have low density in transport, and must be protected from damage. An 8' x 20' pallet can hold 100 sections totalling 2,000'. This could weigh from 4 to 8 tons depending upon the material used.

Installation is envisioned to be performed by a vehicle that carries one pallet of 100 sections and assembles them at a speed of up to 1 mile/hour. As with the manual concepts to provide pallets at 2,000' intervals, 264 trips of 100 mile average must be driven. In 100 hours, this requires 264 truck-miles/hour, or 18 trucks at 15 mph. Trucks must be fitted with cranes for self-unloading.

⁷ These numbers represent only an example and were modified in Phase II.

The assembly vehicle can have three levels of mechanization. Sections can be moved by hand, with fixturing that aligns parts for rapid assembly. Parts can be conveyed by power, under direct operator control. In this case, the operator would initiate placing a section, making a joint, and controlling the forward motion of the vehicle. Alternatively, all of these functions could be initiated by sensors, with the operator performing a monitoring function. The manual system does require more manpower than the powered systems, but at a somewhat lower skill level. The mechanized equipment is expensive, specialized, and the impact upon construction in the case of breakdowns indicates the need for back-up equipment. Energy requirements are expected to be moderate.

Maintenance of a pipeline assembled by this method is not likely to require more than routine familiarity with the procedures and portable tools.

In analyzing these systems, it was determined that some of the systems would be infeasible or very difficult to develop for the job. For an example, the mechanized system of sectioned pipelines would be very difficult to develop utilizing existing couplings. We, therefore, developed alternative S17 to incorporate a new type of coupling.

- Telescoping Sections: S13, S14, S15

A variation of assembling pipe sections utilizes a number of diameters that telescope. There are two advantages:

1. A telescoping set of pipes can be deployed by pulling, without specialized assembly equipment. This produces at least 10 times the length between manually coupled joints.
2. The shipping density can be moderate to high.

The disadvantages are that many tube sizes are required, and all but the smallest is oversized for the flow it carries. A moderate development effort should be adequate to produce a functional system, since no special field vehicle will be required. The cost of components will be high, because of the many tubing sizes that are larger than necessary. The sets of tubes are well protected by the outer shell in storage, and should present no special problems.

Shipping density is quite high. 4000' collapse into 16 sections of 12" diameter, which occupy 4' x 4' x 20' and weigh 16,000 lbs. In comparison, 2000' of 125" wall aluminum sections require 8' x 8' x 20' and weigh about 7,000 lbs. Therefore, telescoping tubes occupy about one-eighth the volume. Tactical supply of tubes during pipeline construction can be done with 9 trucks with an 8-ton capacity. In a 100-hour program, 10 are required since they will be used for installation also.

The major variations of the telescoping pipeline are the type of material used; i.e., steel, aluminum or plastic.

Assembly of the pipeline will require driving a loaded truck to the end of the pipeline. A telescoping section will be unloaded and coupled manually. Then the truck will pull the free end, extending the 20' set to 240'. The joints are expected to seal without attention. Then another section is coupled and the process is repeated. To achieve the desired rate, the coupling and pulling must be done in 3 minutes, which will occupy the truck 45 minutes, each trip. This adds 100 truck-hours, or one more truck.

No dedicated vehicles or unusual skills are required for installation. Maintenance, on the other hand, presents some unusual problems. With 12 pipe sizes, replacing sections requires a larger-than-average inventory. This is partially offset by the fact that undamaged sections of a set are reusable.

5. Non-Pipe Concepts

There are a number of concepts which do not use any form of pipeline for the conveyance of the fuel. Most of these are not reasonable approaches to the proposed problem, but are included for sake of comparison and completeness.

- Trucks: N3, N4

Before a pipeline is operational, fuel must be transported by vehicles. Tank trucks may have a capacity of 10 tons of fuel. This is about 3,000 gallons, 70 barrels. 35,000 bbls/day requires 550 truckloads, each with a 200-mile round trip. In a 20-hour day, 275 trucks are required.⁸ Another 50 trucks are required to provide their fuel. Using rubber bags instead of tank trucks has few advantages over tank trucks. One advantage is that the use of bags allows for a more versatile type of vehicle to be used.

- Water Transport: N6

The only vehicles that have an adequate capacity and operating economy are ships and barges. If there are waterways for these, it is reasonable to assume that the area is developed, and will also have pipelines.

⁸ These numbers were modified slightly in the Phase II analysis.

- Other Non-Pipeline Methods: N1, N2, N5, N7

Conveyors transporting containers such as bags or barrels are many times the component costs and installation cost. Handling of containers at the desired rates does not appear practical. One 42 gallon barrel would be required to arrive every 2 seconds.

Ballistic projection of the fuel by streaming was suggested. Such an approach immediately raises insurmountable technical and environmental issues. (For these reasons it scored the lowest in the Phase I assessment.)

There were some alternatives that were clearly dominated by others. Non-collapsible hosing at low pressure would not gain any advantages over either non-collapsible hosing with high pressure or collapsible hosing with low pressure. All of the alternatives were scored and evaluated, however, and we were thus able to refine and calibrate the scoring system by examining the scores for those systems that would be either very difficult to develop or not as desirable as similar alternatives.

CHAPTER 4 - FIRST PHASE EVALUATION

4.1 INTRODUCTION

This chapter presents the results of the first phase evaluation of the various alternatives tabulated in Chapter 3. The purposes of this first phase evaluation included:

1. Eliminating from further consideration those alternatives that fall short of the mission objectives.
2. Reducing the number of alternatives to a set small enough to enable detailed analysis and comparison.
3. Determination of those attributes with high discriminatory power and eliminating those criteria that do not effectively discriminate among alternatives.

In the preliminary stage of analysis, we could not evaluate with precise detail the utility or score for any candidate system. There were two reasons for this. First, there were many attributes, and in order to evaluate the trade-offs between the attributes, a detailed consolidated cost analysis would have been necessary. This would not have been feasible for the numerous alternatives posed in the previous chapter. Second, it was not clear in which direction detailed state-of-the-art research should be directed. Thus, it was important in the first phase to recognize systems that were potentially superior performers even though development risk might appear to be high.

The first phase evaluation procedure evaluated the various systems for the various attributes, using the general methodology described in Chapter 2. The steps in the procedure were as follows:

- Consolidation of system attributes into categories that can be estimated in a first pass evaluation.
- Evaluating each alternative and component choice for each attribute into an absolute score that can be added to scores for other attributes by using the weighting procedure discussed in Chapter 2.

- Totalling scores for each scenario.
- Analysis of scores and formulation of those concepts appropriate for second-phase analysis.

Each of these principles is described in the following sections.

4.2 CONSOLIDATION OF SYSTEM ATTRIBUTES

The list of attributes presented in Chapter 2 included all possible system characteristics that we could conceive as relevant to the Army. When relevance was questionable, we nevertheless included the attribute to be sure that nothing of significance was lost. In the actual evaluation, a consolidated list of attributes was utilized. The consolidated list was obtained by elimination of certain attributes and aggregation of others. Attributes were eliminated if a) the attributes represented absolute requirements of the system (in which case an inadequate rating would eliminate the system), or b) the various systems were equivalent with respect to the attributes. An example of the latter situation was susceptibility to tapping.

In the aggregation stage, certain groups of related attributes were consolidated, either because analysis showed they were different descriptions of the same factor, or because experience showed that over the set of systems under consideration the individual attribute scores were highly correlated. In these situations, aggregation greatly simplified the evaluation procedure.

The set of attributes that remained were reordered in a hierarchy to show degrees of relationship among them, and the resulting list included the following:

I. System Cost Attributes

- A. Development
 - Cost of component development
 - Cost of installation equipment development
- B. Procurement
 - Component
 - Installation equipment
- C. Support Readiness Operation Cost
 - Shelf Life
 - Weight and volume restrictions
 - Training

2. Development Risk

- A. Risk Level
- B. Dependence of procurement on limited resources

3. Reuseability

- A. Local
- B. Ability to reship

4. System Resource Requirements for Installation

- A. Transportability to theater
 - Pipeline
 - Assembly equipment
- B. Manpower for transport
- C. Transport requirements to site
- D. Special equipment for site transport
- E. Manpower for assembly
 - Specialized
 - Non-specialized
- F. Fuel for installation
- G. Dependence of assembly on special equipment

5. Performance and Reliability

- A. Installation
 - Reliability of installation equipment
 - Degradation of installation under adverse conditions
- B. Operation
 - Reliability as a function of time
 - Maintainability
 - Safety
 - Ease of leak detection
 - Lifetime
 - Vulnerability
 - Field operating costs
 - Manpower Requirements for Operation and Maintenance

This list of attributes was utilized in the evaluation discussed in this chapter.

4.3 SCORING SYSTEM

For each system alternative each attribute was rated on a scale from 0 to 4. The results of this scoring are tabulated in Table 4-1. The interpretation of these scores is as follows:

- 0 - Highly Undesirable
- 1 - Poor
- 2 - Fair
- 3 - Good
- 4 - Excellent

However, these scores were unweighted. A four on one alternative may have a different implication than a four for another alternative. In order to convert this relative score into an actual comparative score, a transformation was necessary for each alternative. The table of transformations is presented in Table 4-2. In developing the transformations, there were two principles employed. These were

1. Non-linear utility
2. Unequal weights of attributes

The non-linearity of utility was necessary to distinguish between the different importances of attribute qualities. Maintainability, for example, was judged to be a moderately important attribute in overall system performance, but possibly less important than other attributes. The difference between a good and an excellent system in terms of maintainability may not be particularly important in the evaluations of an overall system. However, the difference between a poor or fair system on one hand, and an excellent system on another hand, could be substantial. In particular, forming systems, although otherwise scoring extremely well, would suffer in the maintainability area because a broken pipeline would be very difficult to repair. For this reason, we utilized a non-linear scale for the maintainability scoring. Thus, although the overall maximum score was less than the maximum score for other attributes, the difference in scores between a 2 and 3 was substantial.

Other attributes were also characterized by a non-linear scoring transformation. These included development risk and use of manpower. For both of these attributes, there was very little difference between good and excellent scores. There were larger differences between fair and good scores.

The other principle in the scoring transformation was unequal weights. The overall weights of attributes, as determined from the maximum possible score, ranged from 15 for fuel for installation, vulnerability, the two reuseability characteristics and dependence of procurement on limited resources to 150 for each of the two capital costs categories. The categories showing high differences in two relative scores included the two capital costs categories, risk level of development, the probability of a system functioning over time, maintainability, the two assembly manpower categories, and manpower for transport.

TABLE 4-1
RELATIVE SCORES

Concept Code	System Costs						Dev. Risk ability			System Resource Requirements						Performance and Reliability														
	A1	A2	B1	B2	C1	C2	C3	A	B	A	B	A1	A2	B	C	D	E1	E2	F	G	A1	A2	B1	B2	B3	B4	B5	B6	B7	B8
H1	2	3	2	3	3	1	4	2	3	4	4	1	3	2	5	3	4	3	4	4	4	2	4	4	4	3	2	3	3	
H2	2	3	2	3	3	1	4	2	3	4	4	1	3	2	5	3	4	3	4	4	4	3	4	4	4	3	2	3	3	
H3	2	3	2	3	3	2.5	4	2	3	4	4	3	3	3	3	4	3	4	4	4	4	4	2	3	4	3	2	2	2	
H4	1	2	2	3	3	2.5	4	0	1	4	4	3	3	3	3	4	3	4	4	4	4	4	1	1	4	3	2	2	2	
H5	1	2	1	3	0	2.5	4	1	3	4	4	2	2	3	3	4	3	4	4	4	4	4	1	2	4	3	2	2	2	
C1	3	0	3	0	4	4	1	2	3	1	1	4	1	4	4	4	3	1	1	1	2	1	4	2	3	4	3	3	4	4
C2	3	1	3	1	3	4	1	2	2	1	1	4	1	4	4	4	2	3	1	1	2	2	1	2	3	4	3	2	1	1
C3	2	2	2	1	3	3	1	2	2	1	1	3	2	3	4	4	2	3	1	1	2	2	2	2	3	4	3	2	3	3
C4	2	1	3	2	4	3	1	1	4	1	1	4	1	3	4	4	2	3	1	1	2	1	3	2	3	4	3	4	4	4
C5	2	1	3	1	4	3	1	1	4	1	1	4	1	3	4	4	2	3	1	1	2	1	4	2	3	4	3	3	4	4
C6	2	1	3	1	4	4	1	2	4	1	1	4	1	4	4	4	1	3	1	1	1	1	3	2	3	4	3	3	4	4
C7	2	1	3	1	4	4	1	2	4	1	1	4	1	4	4	4	1	3	1	1	1	1	4	2	3	4	3	3	4	4
C8	2	1	3	1	4	4	1	2	4	1	1	4	1	4	4	4	1	3	1	1	1	1	3	1	3	4	3	4	4	4
C9	2	1	3	1	4	4	1	2	4	1	1	4	1	4	4	4	1	3	1	1	1	1	4	1	3	4	3	3	4	4
C10	2	1	2	1	1	3	1	2	2	1	1	3	2	4	3	4	2	3	2	1	2	1	1	2	3	4	3	2	1	1
C11	2	2	2	1	1	3	1	2	2	1	1	3	2	4	3	4	2	3	2	1	2	1	2	2	3	4	3	2	3	3

TABLE 4-1 (CONTINUED)
RELATIVE SCORES

Concept Code	System Costs			Dev. Reuse-ability			System Resource Requirements							Performance and Reliability																
	A1	A2	B1	B2	C1	C2	C3	A	B	A	B	A1	A2	B	C	D	E1	E2	F	G	A1	A2	B1	B2	B3	B4	B5	B6	B7	B8
F1	2	2	2	3	4	2	2.5	2	1	1	1	4	2	4	4	2	3	3	3	1	3	2	2	1.5	3	4	3	2	2	2
F2a	4	2	4	2	3	2	2	4	2	1	1	3	2	4	4	2	3	3	2	1	3	2	3	1.5	3	4	3	4	4	4
F2b	4	1	4	2	3	2	0	4	2	1	1	3	2	4	4	2	3	3	1	1	3	2	3	1.5	3	4	3	4	3	3
F2c	2	1	3	2	3	2	0	3	1	1	1	3	2	4	3	2	3	3	1	1	3	3	2	1	3	4	3	3	3	3
F2d	2	2	3	2	3	2	2.5	3	2	1	1	3	2	4	3	2	3	3	1	1	2	2	2	1.5	3	4	3	2	2	2
F2e	4	2	4	2	3	2	2.5	4	2	1	1	3	2	4	4	2	3	4	1	1	3	2	3	1.5	3	4	3	4	4	4
F2f	2	2	3	2	3	2	2.5	3	1	1	1	3	2	4	3	2	3	3	1	1	3	3	2	1	3	4	3	3	3	3
F2g	4	2	4	2	3	2	2.5	4	2	2	2	3	2	4	4	2	3	4	1	1	3	2	3	1.5	3	4	3	4	4	4
F3a	4	2	3	2	4	3	2.5	4	2	2	2	3	2	4	4	2	3	4	2	1	3	2	4	1.5	3	4	3	3	3	3
F3b	4	0	4	1	4	3	1	4	2	1	1	3	1	4	4	1	3	4	1	1	2	2	4	1.5	3	4	3	3	3	3
F3c	4	0	4	1	4	3	1	4	2	1	1	3	2	4	4	2	3	4	1	1	2	2	4	1	3	4	3	3	3	3
F3d	4	0	4	1	4	3	1	4	2	1	1	3	3	4	4	2	3	4	1	1	2	2	4	1	3	4	3	3	3	3
F3e	4	2	3.5	2	4	3	2.5	4	2	1	1	4	2	4	4	2	3	4	3	1	3	2	4	1.5	3	4	3	3	4	4
F3f	4	2	3.5	2	4	3	2.5	4	2	1	1	4	2	4	4	2	3	4	3	1	3	2	4	1.5	3	4	3	3	4	4
F4	4	1	4	2	4	3	2	1	4	2	1	3	2	4	4	2	2	4	2	1	3	2	3	1.5	0	4	2	3	3	3
F5	2	1	2	2	2	2	2	2	2	1	2	3	2	4	4	2	2	4	1	1	2	1	2	1.5	3	4	3	3	3	3

TABLE 4-1 (CONTINUED)
RELATIVE SCORES

Concept Code	System Costs			Dev. Reuse-ability			System Resource Requirements							Performance and Reliability																
	A1	A2	B1	B2	C1	C2	C3	A	B	A	B	A1	A2	B	C	D	E1	E2	F	G	A1	A2	B1	B2	B3	B4	B5	B6	B7	B8
S1	4	2	3	2	4	2.5	2	1	4	4	4	3	2	2.5	2	3	2	3	2.5	2	2	3.5	3	4	3	4	4	3	4	4
S2	4	2	3	2	4	2.5	2	1	4	4	4	3	2	2.5	2	3	1	1	2.5	2	2	3.5	3	4	3	4	4	3	4	4
S3	4	4	3	4	4	2.5	2	4	4	4	4	3	4	2	2	4	0	0	4	4	4	4	3	4	3	4	4	3	4	4
S4	3	3	2.5	3	4	2.5	2	1	4	4	4	3	4	2	2	4	0	0	4	4	4	4	3	4	3	4	4	3	4	4
S5	4	1	3	1	3	2	2	3	4	2	2	3	2	2	2	4	2	4	2	4	3	3	3	3	2	3	4	4	4	4
S6	4	1	3	1	4	2.5	2	3	4	2	2	3	2	2	2	4	2	4	2	4	3	3	4	2	3	4	4	3	4	4
S7	2	4	2	4	2	2.5	2	2	2	4	4	3	4	2	2	4	0	0	4	4	2	3	2	4	3	4	4	3	3	4
S8	4	4	3	4	2	2.5	2	4	2	3	4	3	4	2	2	4	0	0	4	4	3	3	2	3	3	4	4	3	3	4
S9	3	4	4	4	1	2.5	2	3	2	2	2	3	4	2	2	4	0	0	4	4	2	2.5	1	2	3	4	4	3	3	4
S10	2	1	2	1	2	2.5	2	1	2	4	4	3	1	2	2	4	2	4	2.5	4	1	2.5	2	4	3	4	4	3	3	4
S11	4	1.5	3	2	2	2.5	2	2	2	3	4	3	2	2	2	4	2	4	2.5	4	2	2.5	2	3	3	4	4	3	3	4
S12	3	1.5	4	2	1	2.5	2	2	2	2	2	3	2	2	2	4	2	4	2.5	4	2	3	1	2	3	4	4	3	3	4
S13	1	3	1	1	3	3	2	3	4	1	3	3	3	3	3	4	3	3	4	4	3	3	3	1	3	4	4	4	3	3
S14	1	3	1	1	4	3	2	3	4	1	3	3	3	3	3	4	3	3	4	4	3	3	4	1	3	4	4	3	3	3
S15	1	3	2	2	2	3	2	2	2	1	3	3	3	3	3	4	3	3	4	4	3	3	2	1	3	4	4	2	2	2
S16	2	3	2	3	4	2	2	2	4	4	4	2	3	2	2	3	2	3	3	2	2	3	3	3	3	4	4	4	4	4
S17	3	2.5	3	3	4	2.5	2	2.5	4	3	4	3	2	2	2	3	3	3.5	2.5	2	3	3.5	3	4	3	4	4	3	4	4

TABLE 4-1 (CONTINUED)
RELATIVE SCORES

Concept Code	System Costs			Dev. Reuse-ability		System Resource Requirements						Performance and Reliability																		
	A1	A2	B1	B2	C1	C2	C3	A	B	A	B	A1	A2	B	C	D	E1	E2	F	G	A1	A2	B1	B2	B3	B4	B5	B6	B7	B8
N1	3	0	3	0	3	0	3	2	3	1	1	0	0	1	0	1	1	1	1	3	1	1	1	1	3	4	4	3	1	1
N2	3	0	3	0	3	0	3	2	3	1	1	0	0	1	0	1	1	1	1	3	1	1	1	1	3	4	4	3	1	1
N3	3	4	0	4	3	3.5	3	3	3	4	4	1	4	4	4	4	4	4	4	4	4	4	2.5	2	3	4	4	4	0	0
N4	4	4	0	4	2	2	3	4	4	4	4	2	4	4	4	4	4	4	4	4	4	4	4	2.5	2	3	4	4	.5	.5
N5	4	4	0	0	4	4	3	4	4	4	4	2	4	4	4	4	4	4	4	4	4	4	4	3	1	3	4	4	0	1
N6	2	4	2	4	1	1	3	2	2	4	4	3	4	4	3	4	3	2	4	4	4	2	0	2	2	3	4	4	1	1
N7	0	0	0	0	1	0	3	0	2	1	1	1	1	1	1	1	1	1	1	1	1	0	0	1	0	1	4	3	2	1

TABLE 4-2
SCORING TRANSFORMATION

Score	System Costs						Dev. Risk						Reuse-ability						Systems Resource Requirements						Performance and Reliability									
	A1	A2	B1	B2	C1	C2	C3	A	B	A	B	A	B	A	B	A1	A2	B	C	D	E1	E2	F	G	A1	A2	B1	B2	B3	B4	B5	B6	B7	B8
0	-50	-50	-100	-100	-50	-50	-50	-50	-50	-20	-20	-25	-25	-50	-50	0	0	0	0	0	0	0	0	0	-50	-20	-50	-50	-100	0	-100	-25	-25	-100
1	0	0	0	0	0	0	0	0	0	0	0	0	0	0	0	0	0	0	0	0	0	0	0	0	0	0	0	0	0	0	0	0	0	0
2	13	13	50	50	10	10	10	10	5	5	5	5	5	30	15	15	15	15	15	15	15	15	15	5	5	10	10	5	5	5	5	5	5	15
3	27	27	100	100	20	20	20	50	10	10	10	15	15	50	30	60	60	60	60	60	60	60	60	40	40	25	45	50	10	10	35	10	30	35
4	40	40	150	150	30	30	30	80	15	15	15	20	20	65	45	80	80	80	80	80	80	80	80	65	65	35	65	70	15	15	40	15	45	55

We also utilized severe penalties for systems manifesting scores of 0 for a given attribute. As an example, safety was not a heavily weighted attribute. However, we attached a penalty of -100 for any system exhibiting a score of zero in safety. An example of this was prestressed cylinder formed pipeline system. Because of this safety deficiency, the system rated poorly. (In some sense, the scoring system also reflects the degree of variation of a given attribute. By attaching a rating of 15 to safety we did not mean to imply that safety is unimportant. To the contrary, safety is an important characteristic in pipeline systems. The maximum weighting of 15 was in actuality a recognition of the fact that systems varied very little in safety characteristics with the exception, of course, of prestressed systems.)

Weighting and scoring transformations were derived from conversations with MERADCOM concerning essential characteristics and relative importance of various factors. The transformations were reevaluated and refined after an initial set of scoring tabulations.

4.4 SCORES

The overall scores of the various systems in decending order of score is as follows:

	<u>Alternative</u>	<u>Score</u>
S17	Mechanized sectioned pipe with joint to be designed	959.5
F3(e,f) F2(g)	Formed pipeline from coiled metal strips steel alternative g, aluminum alternative e and f	920.5
F2(e)	Same, steel alternative e	915.5
S3	Manual sectioned joints	915
H3	Flexible, collapsible, low-medium pressure hose	895
F2(a)	Formed from steel strips, alternative a	870.5
H2	Non-collapsible hose	870
F3(a)	Formed from aluminum strips, alternative a	855.5
H1	Low pressure, non-collapsible hose	845
N4	Tanker trucks	825

S6	Welded pipe	815
S1	Mechanized sectioned pipe, existing joint	810.5
S5		785
S8, S16		775
F2(b)		767.5
S11		751.5
S14		747
H4		738
S2		735.5
N3		734.5
S4		734
F2(f)		731
F3(d)		725
S13		722
S12		716
F3(c)		715
F3(b)		702.5
S15		682
N6, C4		673
N5		665
S9		659.5
F1		653.5
C7		653
F4		652.5
C9		648
F2(d)		638.5

F2(c), C5	638
C12, C8, C6, H5	633
C1	627
S10	623
S7	618
F5	550.5
C2	507
C3	506
C11	481
C10	393
N1, N2	2
N7	-440

4.5 CONCLUSIONS AND PLAN FOR PHASE II

Upon examination of the scores of the various alternatives, the following five system concepts were selected as candidates for further evaluation. The five systems represent the highest scoring systems plus the addition of tank trucks. We felt that tank trucks merited further investigation due to the immediate availability of fuel in a trucking system and for the purposes of attribute comparison.

1. Mechanized assembly of sectioned pipeline using steel or aluminum and a coupling (to be designed). This alternative dominates all other mechanized systems using sectioned pipeline and existing couplings.
2. Roll formed cylinder from coiled flat strip. The various metal options were somewhat comparable in scores. In accordance with the order of these scores we considered as the most feasible choices steel and aluminum with a lock bend seam and thermoset seal or a locking strip seam, although others (possibly new ones) were not be ruled out.
3. Flexible, collapsible, low to medium pressure, rolled hose. This alternative dominates both the non-collapsible hoses and the high pressure collapsible hoses. The latter is not feasible and received a very low score in development

risk. The glass reinforced "B" stage thermoset alternative had too low a shelf life to be practical.

4. Manual systems using sectioned pipeline. This system, which is the current system being utilized by the Army, scored well except with respect to the critical attribute of manpower. Existing couplings seem sufficient for manual systems.
5. Tank trucks. This system scored very well in several areas and dominates non-pipe approaches. Its advantage is immediate fuel delivery, and its disadvantages are operating cost and resource requirements.

In order to complete the project we needed to evaluate these five system concepts more accurately and provide some of the details necessary for system development. Such detail included, for example, the nature of the coupling in a mechanized assembly system. In the second phase of the project we evaluated the same attributes again for the five concepts. However, we estimated cost and manpower requirements in more accuracy and detail, and utilized trade-offs of these attributes. The methodology for performing this task is presented in the next chapter.

CHAPTER 5

MISSION DEFINITION FOR COMPARATIVE EVALUATION OF SELECTED CONCEPTS

5.1 INTRODUCTION

In Phase I of the system analysis of mechanized pipeline construction, over 50 alternative concepts were conceived and qualitatively ranked. Five system concepts that scored very high in the preliminary qualitative analysis were subjected to a much more detailed analysis in the second phase to determine the costs and benefits of each. This analysis was also the basis for recommendations about a research and development program, the first major step toward procurement. The five systems that survived the preliminary Phase I evaluation were:

- The base system. Current manually coupled 6" and 8" pipeline as described in section one, Coupled Pipelines, Chapter 9 of TM5-343, Military Petroleum Pipeline Systems.
- A truck haulage system utilizing Army standard 5-ton 6 x 6 tractors, MOD M818, and Army 5,000 gallon bulk tank trailers, MOD M967; again, an existing system.
- New pipeline concept. Laying of continuously formed and seamed 6" and 8" tubing from steel strip.
- New pipeline concept. Mechanized coupling and laying of 20' sections of 6" and 8" pipe with continuous auto feed and attaching of joints and couplings from 8' to 8' x 20' unit modules.
- New concept. 6" and 8" collapsible hose -- long sections and mechanized coupling, flaked in 8' x 20' containers.

All of the cost attributes and those other attributes that appear to be mission-dependent were evaluated in the context of a common mission. The purpose of this chapter is to describe that mission in the detail needed to support the cost and other attribute estimates. The life cycle begins with research and development, except for the existing base-line pipeline system and truck haulage, where the life cycle begins with procurement. To support consistent comparisons, we assumed a common life cycle schedule as follows:

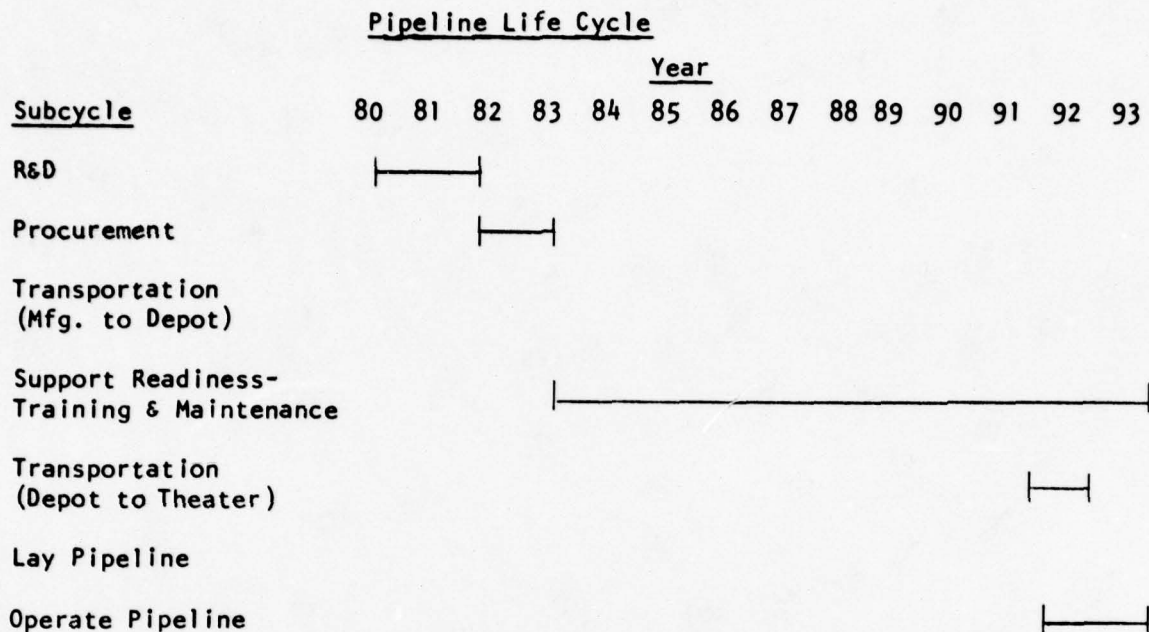

5.2 MISSION DEFINITION

1. Research and Development Program and Subcycle

For each of the new pipeline concepts, the non-government cost for a research and development program was estimated for the entire pipeline system with the exception of existing or common subsystems, modules, components, etc. For instance, conventional existing pumping stations were utilized by all systems. There may be the requirement, however, for the development of an interfacing fitting. The cost and duration of the research and development program was based upon the factoring in of R&D risk.

The outline of the R&D program in Figure 5-1 conforms to the Army system acquisition cycle. On this we have superimposed risk analysis. As an illustrative example, suppose the evaluators agree that the most likely value of cost and duration for a particular stream of development are \$3,500,000 and 28 months respectively. At the same time, they will generate optimistic and pessimistic estimates of cost and duration, expressed as a percentage of the most likely estimates. The product of the two gives optimistic and pessimistic estimates in units of cost and time. The process is illustrated by the following:

FIGURE 5-1
TYPICAL R&D PROGRAM

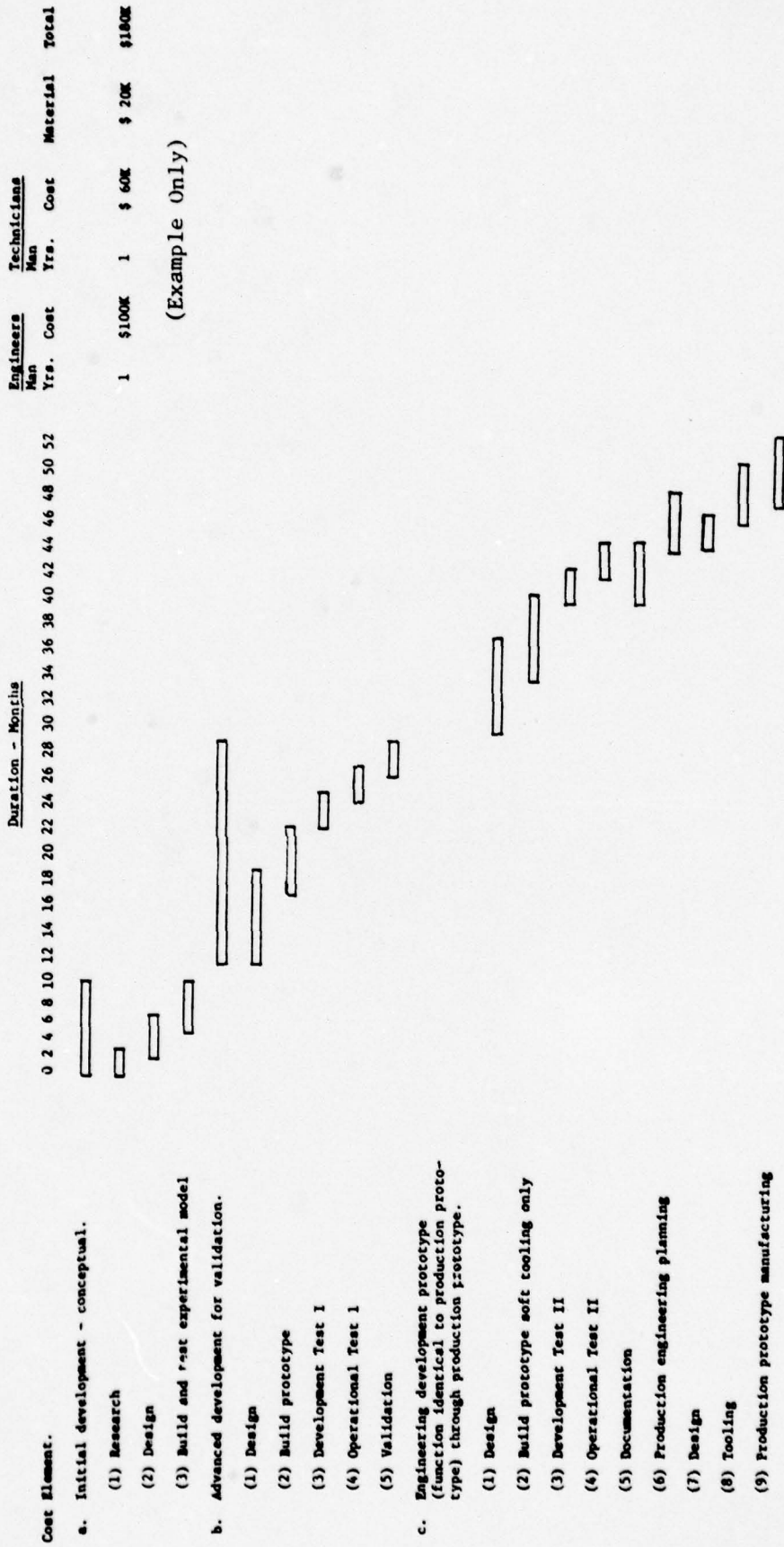

(Example Only)

- Risk Evaluation (Example only)

	<u>Cost</u>	<u>Duration</u>
a. Optimistic	90%	80%
b. Most Likely	100%	100%
c. Pessimistic	200%	150%

- Risk/Cost Summary (Example only)

a. Optimistic	\$ 3,150K	22.4 Mo.
b. Most Likely	3,500K	28
c. Pessimistic	7,000K	42

2. Procurement Program and Subcycle

The principal items in the procurement program are the conduit, its couplings and/or fittings, and support and repair components. The other principal cost item is the pipeline laying equipment. For cost estimating there is only one purchase made, and it included 15% of the procurement cost for the cost of spares. All procurement costs are in 1979 dollars. The procurement for the pipeline laying equipment, however, is for six Quartermaster petroleum pipeline and terminal operating companies. There is one of these companies on active duty at Fort Lee, Virginia, and there are five reserve units. Each company is to have the capability of laying 100 miles of pipeline at the specified rate. Pipeline laying equipment is the specific equipment required for pipeline assembly and will not include any special equipment utilized for crossing streams, rivers, or performing any grade improvement. This latter category of equipment is considered a stand-off for all alternative systems.

Other standard equipment includes the costs of booster pump stations since certain systems may require more booster pump stations than others. For future purposes it was desirable to obtain the costs of transportation equipment per diem since such equipment would be used for a very limited time only. There is also standard equipment such as containers which would be acquired to hold the material in depot and in the theater prior to deployment. The containers would also be utilized in the actual laying of the pipeline. Risk factors concerning procurement were recognized such as the use of critical materials, the sensitivity of the system to cost escalation, and any attributes the system may have toward obsolescence for any reason, and these were also accounted for in the development risk attributes. Aspects of this subcycle include:

- Cost Elements
- Time Frame attributes (1979 dollars were used)

- Duration

Identification of time frame for one time procurement such as year three to year four, or 36 months to 48 months.

- Conduit

- (1) 8", 85 miles
- (2) 6", 34 miles
- (3) Couplings and fittings
- (4) Support and repair components

- Pipeline laying equipment for six Quartermaster petroleum pipeline and terminal operating companies.

- Standard Equipment

- Booster pump stations (based on equations and data supplied by (MERADCOM).⁹

The equations assume:

- Pipeline pump station configuration is similar to those described in the Army Facilities Components Systems Technical Manuals.
- Commercial components of the required size and pressure ratings are readily available.
- Centrifugal pumps driven by high-speed medium duty diesel engines are used.
- Design operating pressure is in the range from 100 psi to 720 psi.

The equations are:

8" Pipeline

$$C = 45,000 + 64.25P + 0.089 PQ$$

6" Pipeline

$$C = 21,875 + 16.33P + 0.089PQ$$

where

C = Cost of pump station in 1979 dollars. Includes diesel-engine-driven pumps, valves, fittings, sand traps, scrapper launchers, etc.

P = Normal operating pressure-psi

Q = Normal rate of flow-gpm

⁹ Letter from W. Studebaker, 24 April 1979

- Transportation company rental (No Procurement; operating costs part of other subcycles)
- Miscellaneous containers

We considered the Mil Van container as well as any standard container that is commercially available. The containers are to be used for shipment only and not for storage in the depot. The exception could be hose; in that particular case the container would be part of the procurement. The Army has ordered 3,000, 40' tandem trailers which will carry two 20' containers. They also have at present 28' stake trailers. All of these trailers are hauled by an appropriate tractor.

- Total life cycle procurement cost

3. Transportation from Manufacturer to Depot

For all land shipments within the States, we considered a cost based on \$96¹⁰ per ton. This includes manufacturer to depot and depot to user and user's return of material to the depot. Each movement is \$96 per ton. We assumed that the manufacturer is somewhere in the Midwest. The procurement would be shipped to either of two depots -- DSA, Columbus, Ohio, or the depot in New Cumberland, Pennsylvania.

4. Support Readiness - Stand-by and Operating Attributes and Costs

The pipeline and spares would remain in inventory at the depot. All equipment would be distributed to the six companies. Equipment spares would be held at the depot. Each year during the two-week reserve training session sufficient pipeline (6 miles) would be withdrawn from the depot and then returned to the depot following the training exercise. The cost for shipment would be \$96/ton each way. Depot cost are not allocated; hence there would be no charges for inventory holding.

- Inventory Holding Costs - None
- Training Costs
 - Material including shipment
 - Maintenance per year
 - Manpower per year
- System Upgrade and Improvement Cost

It is assumed that there is no system upgrade or improvement throughout the life cycle of the alternative pipeline.

¹⁰ MERADCOM Cost Analysis Handbook, Second Edition, Fort Belvoir: U.S. Army Mobility Equipment Research and Development Command, 1979.

5. Transportation from Zone of Interior Depot to Theater Port of Entry Depot

This transportation cost is calculated at \$403/ton.¹¹

6. Lay Pipeline 30 Kilometers per 20-Hour Day

- Lay 85 miles of 8" pipeline over level terrain
- Lay two, 17 mile lengths of 6" pipeline over level terrain; the legs are divergent.

Assume that there are only 122 men out of the 181 men who will be actively engaged working on the pipeline--61 men on each of the two shifts. This company has to have the capability of laying at the prescribed rate. If it is not possible to lay the pipeline at the prescribed rate, the operating efficiency of the concept would be lowered. Drivers for delivering material would be from the transportation truck company and are not included as a manpower limitation; they are a cost.

7. Operate Pipeline Six Months at a Rate of 35,000 Barrels per 20-Hour Day

The pipeline would be operated by two Quartermaster Petroleum Pipeline and Terminal Operating Companies. For both companies there would be 244 men available to operate the line. Each pumping station requires two men to operate and perform first line maintenance. The usual pumping station would have four pumps in series -- three would be operating, one would be on standby. The pipeline would be patrolled by helicopter as well as by walking two-man teams. It is expected there are at least five teams required. We did not assume any particular level of hostile action or vandalism by the civilian population.

All costs of operations that are stand-off between alternative systems were excluded from the life cycle cost analysis.

The following five chapters describe each of the final alternatives and their life cycle costs based on the mission described in this chapter.

¹¹ MERADCOM Cost Analysis Handbook, Second Edition, Fort Belvoir: U.S. Army Mobility Equipment Research and Development Command, 1979.

CHAPTER 6 - ECONOMIC ANALYSIS OF BASE CASE MANUAL SYSTEM

6.1 DESCRIPTION OF SYSTEM

The method of laying pipeline that is now used is manual alignment and assembly of sections of rigid pipe. The twenty-foot sections of pipe are delivered by truck and dropped off approximately in position. A crew of men on the ground aligns the length of pipe, couples the joints, and proceeds to the next joint 20 feet further along. The method of laying this manual pipeline is described in Section 1, Coupled Pipelines, Chapter 9 of TM 5-343, Military Petroleum Pipeline Systems. The basic doctrine for the Petroleum Pipeline and Terminal Operating Company working in a theater of operations is described in FM 10-207, Petroleum Pipeline and Terminal Operating Company. The operational requirement, as described herein in Chapter 5 in the definition of the mission, is to lay a pipeline of 85 miles of 8" thin wall steel tubing sections and two legs of 17 miles each of 6" thin wall steel tubing sections utilizing the current military standard split-ring mechanical couplings. The rates for laying 8" and 6" pipe by a pipeline crew are presented in Table 6-1. In this table and in other tables relating to worker efficiency, it is assumed that a work crew takes a ten minute rest period, leaving fifty minutes per hour as work time. It is also assumed that in a twenty-hour work day, there are two ten hour shifts.

TABLE 6-1
MANUAL PIPELINE LAYING RATES

Pipe Size	Crew Size (Men)	Joint Making Rate-Min/Joint	20' Sections Laid/ 50 Min.Hr.	20' Sections Laid/ 10 Hr. Shift	Length of Pipe Laid/10 Hr. Shift Ft./Shift
8"	9	4.5	11.11	111.11	2,222.22
6"	7	4.0	12.50	125.00	2,500.00

The requirement is to lay the pipeline at a rate of 30 kilometers per 20 hour day, or 18.64 miles per day. The number of crews required to lay a pipeline at 30 kilometers per day and the number of crew shifts available from the Petroleum Pipeline and Terminal Operating Company is presented in Table 6-2.

TABLE 6-2

CREWS REQUIRED TO LAY PIPELINE AT 30 KM/Day (18.64 Miles/Day)
AND MAXIMUM CREWS AVAILABLE FOR PIPELAYING PER PETROLEUM
PIPELINE AND TERMINAL OPERATING COMPANY

<u>Pipeline Size</u>	<u>Required Lay Rate Ft/Day</u>	<u>Crew Shift Rate Ft/10 Hrs.</u>	<u>No. of Crews Required/Day</u>	<u>No. of Crews Available</u>
8"	98,425.44	2,222.22	44.29	13.56
6"	98,425.44	2,500.00	39.37	17.43

It is apparent from the foregoing table that more than one company will be required to lay the manual pipeline at 30 kilometers per day rate. Furthermore, some of the available crews may be needed for checking the layed pipeline, helping unload trucks, and so forth. Hence, we will assume for all calculations that the number of crews available from any one company to lay 8" pipeline would be 12, and to lay 6" pipeline would be 15. A Petroleum Pipeline and Terminal Operation Company laying would then have the capability of laying at the rate presented in Table 6-3.

TABLE 6-3

PETROLEUM PIPELINE AND TERMINAL OPERATING COMPANY PIPELINE LAYING RATE

<u>Pipeline Size</u>	<u>Rate Feet/Day</u>	<u>Rate Miles/Day</u>	<u>Rate KM/Day</u>
8"	12 x 2,222.22 = 26,667'	5.05	8.13
6"	15 x 2,500.00 = 37,500'	7.10	11.43

The number of companies required to lay at a 30 kilometers per day rate is presented in Table 6-4.

TABLE 6-4
 NUMBER OF PETROLEUM PIPELINE AND TERMINAL OPERATING COMPANIES
 REQUIRED TO LAY A PIPELINE AT 30 KM/DAY RATE

<u>Pipeline Size</u>	<u>Rate/Co.-Day KM/Day</u>	<u>Number of Companies Required</u>	<u>Assume</u>
8"	8.13	3.69	4.0
6"	11.43	2.62	3.0

The tactical plan would be to utilize four Petroleum Pipeline and Terminal Operating Companies to lay the 85 miles of 8" pipeline and then to use three of the companies to lay the 6" line while the fourth company is initiating operation of the 8" line. The number of days required to lay the 8" pipeline and the 6" pipeline is presented in Table 6-5.

TABLE 6-5
 20-HOUR DAYS REQUIRED TO LAY PIPELINE MISSION REQUIREMENT

<u>Pipeline Size</u>	<u>Mission Req. Length Req. (Miles)</u>	<u>KM</u>	<u>No. of Laying Companies</u>	<u>Combined Rate/Day KM/Day</u>	<u>Number of Days</u>	
					<u>Reducing Crews</u>	<u>Constant Crews</u>
8"	85	136.79	4	32.52	4.21	4.21
6"	34	54.72	3	34.29	1.60	-
			4	45.72	-	<u>1.20</u>
			Total		5.81	5.41

By reducing the number of companies from four to three after the completion of the 8" line, it is possible to lay the mission pipeline in 5.81 days. By keeping all four crews working on the 6" line, the time can be reduced to 5.41 days. We shall assume that the 5.81 days are acceptable and all subsequent calculations are based upon reducing the number of companies from four to three after the 8" pipeline has been laid.

6.2 LIFE CYCLE COST

The life cycle costs analysis follows the description in Chapter 5. In this and the next few chapters, each of the seven general subcycles from R&D to operation is analyzed in the order they follow in Chapter 5. Any subcycle not applicable to this particular system is commented on.

1. Research and Development Program and Subcycle

Since the manual pipelaying system already exists, there is no need for a research and development program. Hence, this subcycle is absent, and the cost incurred is \$0.0K.

2. Procurement Program and Subcycle

For the purposes of this study, the best available cost data are used for the lightweight steel tubing sections. Unfortunately, there is no recent procurement history to use as a cost base and most pipe mills do not have tooling to produce the tubing sections. The following prices are based on an informal discussion with Cal-Metal Corporation on March 28, 1979.

Pipeline Section Size:

8" Grooved Pipe	\$373.44 for a 20' joint
6" Grooved Pipe	\$297.00 for a 20' joint

It should be pointed out that these quotations are appreciably higher than prices obtained in 1976. The cost for comparable aluminum grooved pipe in 1976 was quoted as \$206.09 for an 8" section, and \$143.12 for a 6" section.¹² If these price quotations were inflated at 39.4% which represents the rise in aluminum mill shapes from 1976 to 1979 as taken from the MERADCOM Cost Analysis Handbook, they would still be 23% and 33% higher, respectively than the prices above. Hence, we are of the opinion that the 1979 quotations may be somewhat high. They are, however, used for the life cycle cost analysis for both the manual pipeline laying system and the mechanized pipeline laying system presented in Chapter 9. Sensitivity analysis using modified costs is presented in Chapter 11.

¹² Wayne E. Studebaker, Military Petroleum Pipeline Systems, Report 2249, (Fort Belvoir, Virginia: U.S. Army Mobility Equipment Research and Development Command), June 1978, page 88.

- Quantity Requirements for Pipeline Mission

Section and Coupling Calculation for:

$$85 \text{ miles of } 8'' \text{ pipeline} - \frac{85 \text{m} \times 5,280' / \text{m}}{20'} = 22,440 \text{ } 8'' \text{ sections \& couplings}$$

Section and Coupling Calculation for:

$$34 \text{ miles of } 6'' \text{ pipeline} - \frac{34 \text{m} \times 5,280' / \text{m}}{20'} = 8,976 \text{ } 6'' \text{ sections \& couplings}$$

Based on an analysis of pressures and flow rates, pump stations for the 8'' pipeline are required every 9.5 miles and stations for the 6'' line are required every 9.7 miles. Consequently, 9 and 4 stations are required for the two sets of lines respectively.

- Cost Calculation for Pump Station for 8'' Pipeline

$$\text{Cost each} = \$45,000 + 64.25 P + 0.089 PQ$$

where

$$P = 500 \text{ psi}$$

$$Q = 1,225 \text{ GPM (BHP} = 417)$$

$$\begin{aligned} \text{Cost each} &= \$45,000 + 64.25 \times 500 + 0.089 \times 500 \times 1,225 \\ &= \$131,637.50 \end{aligned}$$

- Cost Calculation for Pump Station for 6'' Pipeline

$$\text{Cost each} = \$21,875 + 16.33P + 0.089 PQ$$

where

$$P = 600 \text{ psi}$$

$$Q = 612.5 \text{ GPM (BHP} = 250)$$

$$\begin{aligned} \text{Cost each} &= \$21,875 + 16.33 \times 600 + .089 \times 600 \times 612.5 \\ &= \$64,380.50 \end{aligned}$$

● Procurement Costs for Current Manual System

<u>Item</u>	<u>Quantity</u>	<u>Price 1979\$</u>	<u>Total Cost \$(000)</u>
20', 8" Grooved Pipe Sections (lightweight steel tubing)	22,440	373.44	8,380.0
20', 6" Grooved Pipe Sections (lightweight Steel Tubing)	8,976	297.00	2,665.9
8" Couplings	22,440	21.90	491.4
6" Couplings	8,976	13.40	120.3
Pump Station for 8" Pipeline	9	131,637.50	1,184.7
Pump Station for 6" Pipeline	4	64,380.50	257.5
Subtotal without spares			13,099.8K
15% Spares			<u>1,965.0K</u>
Total			15,064.8K

3. Transportation Subcycle - Manufacturer to CONUS Depot or Unit

	<u>Quantity</u>	<u>Total Item Weight Tons or equiv. tons on cube basis</u>	<u>13 Trans. Cost Per Ton \$</u>	<u>Trans. Cost \$(000)</u>
8" Pipeline Section @ 212 lbs. and 256 Equivalent lbs. when costed on a cubed basis ¹⁴	22,440	2872	96	275.7
6" Pipeline Section @ 170 lbs.	8,976	763	96	73.2

¹³ MERADCOM Cost Analysis Handbook, 2nd Edition

¹⁴ Military Petroleum Pipeline Systems, TM 5-343 (Washington: Headquarters, Department of the Army, 1969)

8" Malleable Iron grooved couplings @ 22.75 lbs.	22,440	255	96	24.5
6" Malleable Iron grooved couplings @ 13.5 lbs.	8,976	61	96	5.9
Pump station for 8" pipeline @ 12 tons	9	108	96	10.4
Pump Station for 6" pipeline @ 9 tons	4	36	96	3.5
	<hr/>	<hr/>	<hr/>	<hr/>
Subtotal before Spares		4,095		393.2
Spares @ 15%		<u>614</u>		<u>59.0</u>
Total		4,709		452.2

4. Support Readiness Subcycle -- Standby and Operating Attributes and Costs

In accordance with the mission definition, six miles of 8" pipeline are taken from the depot and one mile of pipeline shipped to each of the six Quartermaster Petroleum Pipeline and Terminal Operating Companies which are on two week reserve training. Depot costs are not allocated, and hence there are no charges for inventory holding. The support readiness is carried out over a ten year period.

- Inventory Holding Costs -- None
- Training Costs

The training costs include the shipment of material from the depot and return to the depot, maintenance costs for the equipment that is used during the two week training period each year for ten years and the manpower cost for the two week training period each year for ten years.

- Transportation Costs

Weight of one mile of 8" pipeline =

$$\frac{5,280'}{20'} \times \frac{(256 \text{ lbs/section} + 22.75 \text{ lbs./couplings})}{2,000 \text{ lbs/ton}} = 36.8 \text{ tons}$$

- 10 year Transportation Cost =

$$2 \text{ trips/year} \times 10 \text{ years} \times (6 \text{ miles} \times 36.8 \text{ tons/mile} + 1 \text{ station} \times 12 \text{ tons/station}) \times 1.15 \text{ spares} \times \$96/\text{ton} = \$514.0K$$

- Operating and Maintenance (O&M) Costs

O&M cost for pump for station for 8" pipeline

The operating cost is based on the BHP required and the data supplied in MERADCOM Report 2249 Military Petroleum Pipeline Systems. For the 430 BHP station, the cost is \$12.70 per hour. Based on the eighty hours of pump station operation during the annual two week training period for each company, the total cost is

$$80 \times \$12.78 \times 6 \times 10 = \$61.3K$$

- O&M Cost of a R-600 ST Mack Tractor or equivalent (56,070 GVW rating) and 40' flatbed trailer, 34 ton capacity. Based on the Cost Reference Guide for Construction Equipment, 1979 edition, the hourly cost of the combination is

Tractor and Trailer Cost Per Hour

<u>Cost Category</u>	<u>\$/Hour of Operation</u>	
	<u>Tractor</u>	<u>Trailer</u>
Overhaul Parts & Supplies	0.71	0.46
Operating Parts & Supplies	1.18	0.43
Fuel	3.18	-
Lube	.56	0.09
Tires	<u>3.25</u>	<u>0.57</u>
Total	8.88	1.55

- O&M Cost Per Hour for Tractor and Trailer

$$= \$8.88 + 1.55 = \$10.43/\text{Hour}$$

- 10 Year Cost = 2 tractor/trailers/company x 6 companies x 80 hours x 10 years x \$10.43/hour = \$100.1K
- Total O&M Costs

Pump Stations	= \$ 61.3K
Tractor/Trailers	= <u>\$100.1K</u>
	\$161.4K

- Manpower Costs

Average Cost per working man per year in Petroleum Pipeline and Terminal Operation Company = \$14,600/year, including prorated share of administrative and support personnel costs.

- 10 Year Manpower Costs =

$$\frac{14}{365} \times \$14,600/\text{man year} \times 122 \text{ men/company} \times 6 \text{ companies} \times 10 \text{ years} = \$4,099.2K$$

It is assumed that the company supplies drivers during training exercises.

- Summary of Training Costs

Transportation	\$ 514.0K
O&M	161.4K
Manpower	<u>4,099.2K</u>
Total	\$4,774.6K

- System Upgrade and Improvement Cost

It is assumed that there is no system upgrade or improvement throughout the life cycle of the current manual pipeline system.

- Summary of Support Readiness Costs

Inventory Holding Costs	\$ 0.0K
Training Costs	4,774.6K
System Upgrade	<u>0.0K</u>
Total	\$4,774.6K

5. Transportation Subcycle - CONUS Depot or Unit to Theater POE Depot

The cost of shipment was assumed to be \$403 per ton based upon transportation cost factors for a theater in Europe or the Near East.¹⁵

- Total tonnage from Transportation Subcycle including spares = \$4,709 tons
- Transportation Cost = 4,709 tons x \$403/ton = \$1,897.7K

6. Mission - Lay Pipeline at a Rate of 30 KM per 20-Hour Day

The mission requires laying 85 miles of 8" pipeline over level terrain and the laying of two 17 mile lengths of 6" pipeline over level terrain. The two legs are to be divergent. All statistics for the number of Petroleum Pipeline and Terminal Operating Companies required to lay the pipeline at the specified 30 kilometer per day rate are presented in section 6.1, description of the system.

- Petroleum Pipeline and Terminal Operating Company Requirements

A summary of Table 6-5 is presented below in Table 6-6.

TABLE 6-6

SUMMARY OF 20-HOUR DAYS REQUIRED TO LAY PIPELINE WITH
MAXIMUM MANPOWER EFFICIENCY

<u>Pipeline Size</u>	<u>Mission Req. Length-Miles</u>	<u>Number of Laying Companies</u>	<u>Number of 20-Hr Days Req.</u>
8"	85	4	4.21
6"	34	3	<u>1.60</u>
		Total	5.81

- Transportation medium truck company requirements

In addition to the Petroleum Pipeline and Terminal Operating Company requirement, there is also the requirement for manpower and tractor/trailers from a transportation medium truck company (container/cargo). The transportation medium truck company delivers the pipe and couplings to pre-

¹⁵ MERADCOM Cost Analysis Handbook

determined positions along the pipeline as it is being laid.

The company has 183 men total, of whom 120 are drivers. The remainder are administrative and support personnel. The men are capable of operating two, 10-hour shifts per day and have 60 tractors. The annual cost per driver is \$16,033. It is assumed that at any one time 25% of their vehicles will not be operable in accordance with FM 101-10-1. It is also assumed that the trailers are 40' in length with a capacity of 34 tons. Each trailer is capable of holding two unit loads of pipe. The unit and trailer loads for pipe are presented in Table 6-7.

TABLE 6-7

UNIT AND TRAILER LOADS

Pipeline Size	Pipe Sections per 8' x 8' x 20' Unit Loads		Unit Loads & Sections per 40' Trailer Load	
	Sections	Weight-Lbs.	Unit Loads	Sections
8"	100	21,200	2	200
6"	169	28,730	2	338

The required number of trips of trailer loads is presented in Table 6-8 for each size of pipeline.

TABLE 6-8

TRAILER TRIPS REQUIRED

Pipeline Size	Total Sections for Mission	Trailer Loads and/or Trips (RT)	Average Round Trip Distance-Miles
8"	22,440	112.20	85.0
6"	8,976	26.56	187.0
8"	Couplings	10	85.0
6"	Couplings	2	187.0
8"	Pump Stations	5	85.0
6"	Pump Stations	2	187.0

For each size pipeline, the total round trips are presented in Table 6-9. The time per round trip is based on the truck travelling at an average speed of 15 miles per hour, and assumes a loading and unloading time of six total hours. (This includes stringing the pipe along the pipeline route).

TABLE 6-9
TRACTOR-TRAILER HOURS

<u>Pipeline Size</u>	<u>Total Round Trips</u>	<u>Time/Round Trip-Hours</u>	<u>Total Time Hours</u>
8"	128	11.67	1,494
6"	<u>31</u>	<u>18.47</u>	<u>573</u>
Total	159	-	2,067

- Tractor/trailer requirement - Based upon the requirement for completing the pipeline in 5.81 days, the available hours are 116.2 hours based upon the following calculation:

$$\text{Available hours} = 5.81 \text{ days} \times 20 \text{ Hour/Day} = 116.2 \text{ Hours}$$

- The nominal number of tractor trailers is determined by the ratio of values obtained from the last two calculations. This result is divided by .75 to account for the fact that additional trucks are required because of unscheduled down times

$$\text{Number of tractor-trailers} = \frac{2067}{.75 \times 116.2} = 23.7$$

Thus the actual requirement (after rounding) is 24 tractor-trailers and 48 drivers

- Lay Pipeline Subcycle Costs

The lay pipeline subcycle costs are of two types -- equipment operating and maintenance and manpower.

- O&M Costs

The 24 tractor/trailers will operate 2,067 hours. Hence, the O&M cost is arrived at by the following calculations:

- Tractor-Trailers

$$O\&M = 2,067 \text{ Hrs.} \times 10.43/\text{Hr.} = \$21.6K$$

We have assumed that the need for any other equipment other than the tractor/trailers would be common to the other systems with the exception of the truck haulage system. Therefore, we have not identified any other operating and maintenance costs.

- Manpower Costs

The manpower costs are presented in the following calculations for the two principal types of Army units required.

<u>Army Units</u>	<u>Companies</u>	<u>Number of Days</u>	<u>Company Days</u>
Petroleum Pipeline and Terminal Operating Co.	3	5.81	17.43
	1	4.21	<u>4.21</u>
		Total	21.64

- Petroleum Pipeline and Terminal Operation Company Manpower Costs = $\frac{21.64}{365} \text{ Company Days} \times 122 \text{ men/Company} \times \$14,600/\text{man year} = \$105.6K$

- Transportation Medium

Truck Company Manpower Costs =

$$48 \text{ men} \times \frac{5.81}{365} \text{ days} \times \$16,033/\text{man day} = \$12.3K$$

- Total Manpower Costs =

Petroleum Pipeline and Terminal Operating Company	\$105.6K
Transportation Medium	
Truck Company	<u>12.3K</u>
	\$117.9K

- Total Lay Pipeline Costs

O&M Costs	\$ 21.6K
Manpower Costs	<u>117.9K</u>
Total	\$139.5K

7. Operate Pipeline for Six Months at a rate of 35,000 barrels per 20 hour-day

The pipeline is operated by two Petroleum Pipeline and Terminal Operating Companies. In accordance with FM 10-67, each company can operate approximately 60 miles of pipeline. Each pumping station requires at least two men on duty at all times when operating. For maintenance purposes, the usual pumping station has four pumps in series but only three would be operating at any time. The cost of operating the line includes both equipment operating and maintenance as well as manpower.

- O&M Costs

The only operating and maintenance costs that are included in the study are those for the pump stations for 8" pipeline and the pump stations for 6" pipeline. The O&M cost for a pump station for the 8" pipeline is \$12.78 per hour based on the 430 BHP rating, as noted in the section on Support Readiness. The O&M cost for a smaller pump station, also based on MERADCOM Report 2249 and the 260 BHP rating, is \$8.17 per hour.

$$\begin{aligned} \text{Thus, O\&M costs} &= \frac{20 \text{ hrs} \times 365 \text{ days}}{2} [9 \text{ (large pump stations)} \times \\ &\quad \$12.78 \text{ hr.} + 4 \text{ (small pump stations)} \times \$8.17/\text{Hr}] \\ &= 3,650 \text{ hrs.} \times 147.7/\text{hour} = 539.1\text{K} \end{aligned}$$

In addition to the regular O&M costs, based on MERADCOM Report 2249, one overhaul is performed on each pumping station. Based on overhaul costs in Report 2249 as well as the transportation involved, this cost is estimated to be \$476.5K. (This consists of \$84.5 transportation cost and \$392.1 for the overhauls of the 13 stations.) The total O&M cost is thus \$1015.6K.

- Manpower Costs

The manpower costs are incurred from the two Petroleum Pipeline and Terminal Operating Companies, each with 122 men and an annual man year cost of \$14,600.

Total Manpower Costs =

2 companies x 122 men/company x 1/2 year x \$14,600/man year
= \$1,781.2K

● Total Pipeline Operating Cost

O&M \$1,015.6K

Manpower 1,781.2K

Total \$2,796.8K

8. Summary of Life Cycle Costs of the Base System -- Manually
Coupled 6" and 8" Pipeline

<u>Cycle</u>	(K\$)
Research and Development	0.0
Procurement	15,064.8
Transportation-Manufacturing-CONUS Depot	452.2
Support Readiness	4,774.6
Transportation-CONUS Depot-Theater	1,897.7
Lay Pipeline	139.5
Operate Pipeline	<u>2,796.8</u>
Total	\$25,125.6

CHAPTER 7 - ECONOMIC ANALYSIS OF TRUCK HAULAGE SYSTEM

7.1 INTRODUCTION

This method of transporting fuel is the use of tanker tractor/trailer combinations and an existing road network. The characteristic that distinguishes this system from the other alternative systems is that there is no installation of the system. The system is available for immediate use, and this, of course, offers great advantages in flexibility. On the other hand, the system involves a large capital outlay for procurement.

This chapter presents the life cycle cost analysis of the truck haulage system. The system utilizes Army 5-Ton, 6x6 tractors, Model 818, and Army 5000 gallon Bulk Tank Trailers, Model M967. The mission is to deliver 35,000 barrels of petroleum fuels per day for one six-month period between the port of entry of the theater and the inland terminals 100 miles away. The truck cycle was assumed to be as follows:

<u>Operation</u>	<u>Rate</u>	<u>Cycle Time</u>
Fill	600 gpm	8.33 minutes
Drive Out	15 mph	400 minutes
Unload	600 gpm	8.33 minutes
Dead Head Back	15 mph	400 minutes
Wait		<u>20 minutes</u>
Total Time		836.66 minutes or 13.94 hrs.

The critical number in the life cycle cost calculation is the number of trucks required for the mission assuming a 20 hour per day operation. This is computed in the following manner:

$$\text{Number Required} = \frac{35,000 \text{ barrels/day}}{5,000 \text{ Gal/Truck}} \times 42 \text{ Gal/Barrel} \times 13.94 \text{ hrs/cycle}$$
$$\div 20 \text{ hr/day} = 205 \text{ trucks}$$

However, since it is assumed that any time only 75% of the trucks are available, 274 trucks and 548 drivers are needed. The life cycle cost analysis follows directly from these numbers.

7.2 LIFE CYCLE COST COMPUTATION

1. Research and Development Program and Subcycle

It is assumed that no research and development is required.

2. Procurement Program and Subcycle

Based on information supplied by MERADCOM, the procurement cost is

<u>Item</u>	<u>Quantity</u>	<u>Unit Price 1979\$</u>	<u>Total Cost \$(000)</u>
Tractor, Mod 818, 5T 6 x 6	274	37,623	10,308.7
Trailer, Bulk Tank Mod M967 5,000 Gallon Capacity	274	35,000	9,590.0
Spares @ 15%	-	-	<u>2,984.8</u>
Total Procurement			22,883.5K

3. Transportation Subcycle Manufacturer to Depot or Using Unit

This involves the transportation of vehicles to the truck companies

<u>Vehicle</u>	<u>Quantity</u>	<u>Weight Each Tons</u>	<u>Total Tons</u>	<u>Shipment Cost per Ton</u>	<u>Transportation \$(000)</u>
Tractor	274	6.0	1644	\$ 96	\$157.8
Trailer	274	4.5	1233	96	118.4
Spares	41.1	10.5	<u>432</u>	96	<u>41.5</u>
Total			3309		\$317.7

4. Support Readiness Subcycle

- Inventory Holding Cost

It is assumed in the mission description that there are no inventory holding costs.

- Training Costs

These include transportation, operation and maintenance, and man-power costs for the training session. To compute these costs

in a parallel manner as for the other systems, it is assumed that enough drivers are being trained each year to meet three times the mission delivery capability. Since 548 drivers are needed for the mission, 1644 drivers (who drive 822 trucks) should be trained. However, during the 2 week period it should not be necessary to devote a great deal of training time to actual driving. Probably not more than two hours per year per driver (or four per truck) would be charged to training. Thus, the total training costs can be computed as follows:

- **Transportation Costs**

Since every medium transportation truck company has vehicles in its possession at all times, there are no transportation costs for training.

- **Operation and Maintenance**

Based on the Cost Reference Guide for Construction Equipment, the cost per hour for each tank truck is \$14.51 per hour. Using 822 trucks for four hours per year for 10 years, the total cost is \$477.1K

- **Manpower Costs**

At a cost of \$16,033 per man year (drivers), using 164 men for two weeks for ten years, the total cost is

$$\$16,033 \times 14/365 \times 1644 \times 10 = \$10,110.0K$$

- **Total Training Costs are \$10,587.1K**

- **System Upgrade and Improvement Costs**

It is assumed that there are no such costs.

- **Total Support Readiness Cost are \$10,587.1K**

- **5. Transportation Subcycle - CONUS Depot or Unit to Theater POE Depot**

Based on the data in the section Transportation Subcycle Manufacturer to Depot using Unit, and a shipping cost of \$403 per ton, the total cost is

$$3309 \text{ tons} \times \$403/\text{ton} = \$1333.5K$$

- **6. Install System**

For this system, the cost of installation is zero.

7. Operate System for Six Months at 35,000 Barrels per 20-Hour Day

● O&M Costs

Based on 20 hours per day for 6 months, 205 trucks operating at any time and an operating cost per hour of \$14.51 (See Operation and Maintenance). The total cost is

$$205 \times 182.5 \times 20 \times 14.51 = \$10,857.1K$$

● Manpower Costs

For the 548 men at \$16,033 per man year and for 6 months, the manpower costs are

$$\$16,033 \times 548 \div 2 = \$4,393.0K$$

● Total Operating Costs

\$15,250.1

8. Total Life Cycle Cost (\$)

Research and Development	0
Procurement	22,883.5K
Transportation-Manufacturing to Depot	317.7K
Support Readiness	10,587.1K
Transportation to Theater	1,333.5K
Install System	0
Operate System	<u>15,250.1K</u>

Thus, total life cycle cost is \$ 50,371.9K

CHAPTER 8 - ANALYSIS OF FORMING CONCEPT

8.1 INTRODUCTION

This chapter presents the final analysis of the forming system. In this concept, coils of flat metal strip would be delivered into position along the pipeline route. A forming machine would form the strips into a cylindrical shape and form a longitudinal seam. The types of seams that scored well in the Phase I analysis were lock bend seams with thermoset seals and locking strip seams. The analysis performed in Phase II emphasized but was not restricted to these subalternatives.

The conclusion from the second phase analysis was that forming is less feasible than originally judged. An actual forming system would be extremely large and costly. Scores for installation equipment cost, transportability and reliability of installation equipment, and degradation under adverse conditions would all substantially decrease. The highest scoring forming system was rescored under the Phase I criteria, and the resulting score was substantially less than the other Phase II concepts. On these bases, we eliminated the system as a final candidate and did not compute the life cycle costs. The chapter presents the reassessment and revised scoring.

8.2 FEASIBILITY ANALYSIS

The concept is to coil the longest possible strip of flat sheet metal that can be conveniently transported. This is brought to a forming machine, where it is placed on an unwind stand. The free end is threaded through a set of forming rolls which bend it into a cylindrical shape. The edges must then be joined and sealed. Finally, a cutoff mechanism is required to permit terminating a length of pipeline. There are several reasons why this process is appealing and scored well in the evaluation process.

The pipeline stock is very compact and quite inexpensive before installation. Installation is envisioned as a smooth continuous process with low man-loading requirements. Furthermore, the resulting pipeline is of high quality and reliability, suitable for a permanent installation. These features combine to make the forming option attractive on first investigation.

To assess the feasibility of this system, and to estimate the operating parameters, vendors were contacted. There are a large number of companies who do contract roll forming. Some of them specialize in tubing manufacture. A second category of vendors design and build roll forming equip-

ment. To seam the roll formed shape, a number of processes were investigated, and appropriate vendors were contacted. A final area of inquiry was directed toward identifying groups who have had experience related to our desired end product, namely a portable tube mill. The general results of these inquiries indicate that some operations of the tube making process are routine and equipment is readily available. Other steps require equipment that has been specially designed for mobile operations. There are remaining steps that are not so readily performed and require further research.

- Metal Stock

In the quantities required, sheet steel of .100" thickness, sheared to 20' or 26' wide, is available from suppliers. A roll of steel 8' in diameter, with a 4' diameter core, holds 4500' and weighs 39,000 lbs. which is probably twice as heavy as practical. 20,000 lbs. is 6.5' in diameter, and is 2300' long.

- Stock Reel

An unwind stand for a 10 ton stock reel is a substantial structure, probably on the order of 2 tons. It must be convenient to reload. This is a purchaseable item with little development needed.

- Reloading

In order to utilize stock delivery trucks to their maximum advantage, and therefore require the fewest trucks, stock deliveries will not be in phase with pipe former's requirements. For this reason the reel must be moved into place ahead of the forming machine. The pipe former will encounter reels every 2300'. It is difficult to make them coincide with the end of the last reel, so some method will be required to adjust the difference. The most straightforward solution is to provide a truck with a crane, whose function is to retrieve reels of stock and load them into the pipe former. It can also be used to perform various other functions between retrievals.

- Forming

Vendors who construct roll forming equipment describe the pipe forming section to consist of 6 roll stands spaced on about 20' centers. This results in a 10' long assembly. Operating speeds are generally about 30' per minute, but 70' per minute is still considered reasonable. There do not seem to be any strict limits preventing the desired rate of 90' per minute, except that more power will be required. The rough estimate is that 25 hp is more than adequate.

- Seaming

The edges of the roll formed tube must be joined with a seam that is as strong as the tube wall, and is completely sealed. Several methods have been examined to make this seam.

Commercially available tube and pipe has a welded seam.. The cleanest joint is usually a resistance welded butt seam with the upset removed. Minimal equipment for this purpose is estimated to cost \$50-\$70,000. The limiting factor is speed. About 5' per minute is an average operating speed, and vendors do not believe that this equipment can produce more than 10' per minute. A company that specializes in the design and construction of pipe mills quotes entirely different speeds; 75' per minute is routine for their high frequency welding. According to this vendor, the equipment to perform the entire operation from coiled stock to finished pipe is 200' long. Furthermore, it is highly sensitive to alignment and speed stability. The vendor does not believe that this equipment can be reduced to a size practical for a mobile unit, nor does he believe that it can be made to tolerate the varying speeds and stresses inherent in mobile operation. Arc welding has speed limitations. If the power is increased in an attempt to weld faster, poor penetration and a great deal of spatter results. However, this equipment is much smaller and less expensive, suggesting the possibility of multiple welders following the pipe former, each at a fraction of the total speed. About ten units would be required operated in a leapfrog sequence, where the last unit is moved up to the first position when its weld joins the beginning of the weld of the next unit. The process seems quite unwieldy.

A lockbend is often used in roll forming thinner stock. In 0.100 inch thick steel it is predicted that another 6 roll stands, adding another ten feet to the equipment, will be required. This can operate at the desired rolling speed. Unfortunately, a lockbend is not a seal, and is likely to be quite bulky in this stock thickness. With the addition of a gasket, hot-melt, or thermoset sealant, this process could possibly meet the output requirements. One disadvantage is the ponderous equipment involved, but the crippling defect is that the lockbend reduces the pressure capability by an order of magnitude.

Other, less common welding processes were examined to determine if it is possible to increase the rate at which the weld can be made. The introduction of metal power into an oxygen jet produces extremely high temperatures for fast flame cutting. This is not usually employed as a welding process, but led to considering not only powdered fuel but powdered oxidizers in the form of metal oxides. The conclusion of this line of reasoning was the thermit process. Used for many years to weld rails, it

requires only two components; powdered aluminum and iron oxide. When the mixture is ignited, the aluminum burns, or oxidizes in the oxygen given off by the heated iron oxide. The iron oxide is reduced to metallic iron, in molten form because of the heat of the reaction.

To apply the thermit process to pipe welding, a rapid method of handling the powder must be devised. A possible solution is to provide long plastic film sausages filled with powder. These would be laid onto the seam after the pipe was formed, and ignited at the far end. Depending upon composition, the reaction can be adjusted to travel at about the forming rate. This permits laying the next sausage while the previous one is burning. Since the molten iron must be contained, one edge of the formed pipe can be formed into a shallow trough, and the other can overlap one sidewall of the trough to lock the edges together, and to dip into the melt, assuring a good weld. Vendors of materials for this process express some concern about the method of containing the reaction. This may be a factor that complicates and slows the process below the requirements.

- Cooling

In commercial pipe production, the weld is cooled before trimming and subsequent handling. For a mobile application, it may be possible to omit this to avoid lengthening the machine still further.

- Cutoff

To permit moving the machine independently of the pipeline, the pipe must be cut. In this case, a travelling cutoff mechanism is not required because pipe production will be stopped for cutting. A bandsaw or cutting torch, properly guided, can perform this function.

- Butt Welding

To connect to existing pipeline, mechanical connectors or butt welding can be used. The butt welding process is preferable in an all-welded system. This equipment requires guiding and clamping motions, with high frequency resistance equipment similar to the seam welding equipment. Butt welding is also applicable for joining a new roll of stock to the end of the old roll while the process is running. This must operate on the fly, and therefore may take up more space than can be afforded on mobile equipment.

8.3 CONCLUSIONS AND REEVALUATIONS

This evaluation leads to some inevitable conclusions regarding the feasibility of continuous forming for the rapid deployment of pipeline. The

seaming and sealing processes identified fall into four categories: impractical to implement, unacceptable pressure capability, unacceptable rate, and equipment too ponderous and unwieldy for this application. Accordingly, forming is considered unfeasible for the given pipelaying scenario. However, the resistance welded version, although impractical for a tactical application, has other attributes that may make it attractive for the subsequent installation of more permanent pipeline.

In the context of the Phase I scoring, the scores for the best possible forming alternatives were reevaluated. As an example, alternative F3e had a revised score of 605 and this indicates without a life cycle cost analysis that the concept is not as desirable as the others. The revised individual attribute scores for alternative F3e is presented in Table 8-1. Revised scores are lower in cost, development, assembly equipment reliability, transport requirements and degradation under adverse conditions. A hypothetical machine is depicted in Figure 8-1.

FIGURE 8-1
HYPOTHETICAL FORMING MACHINE

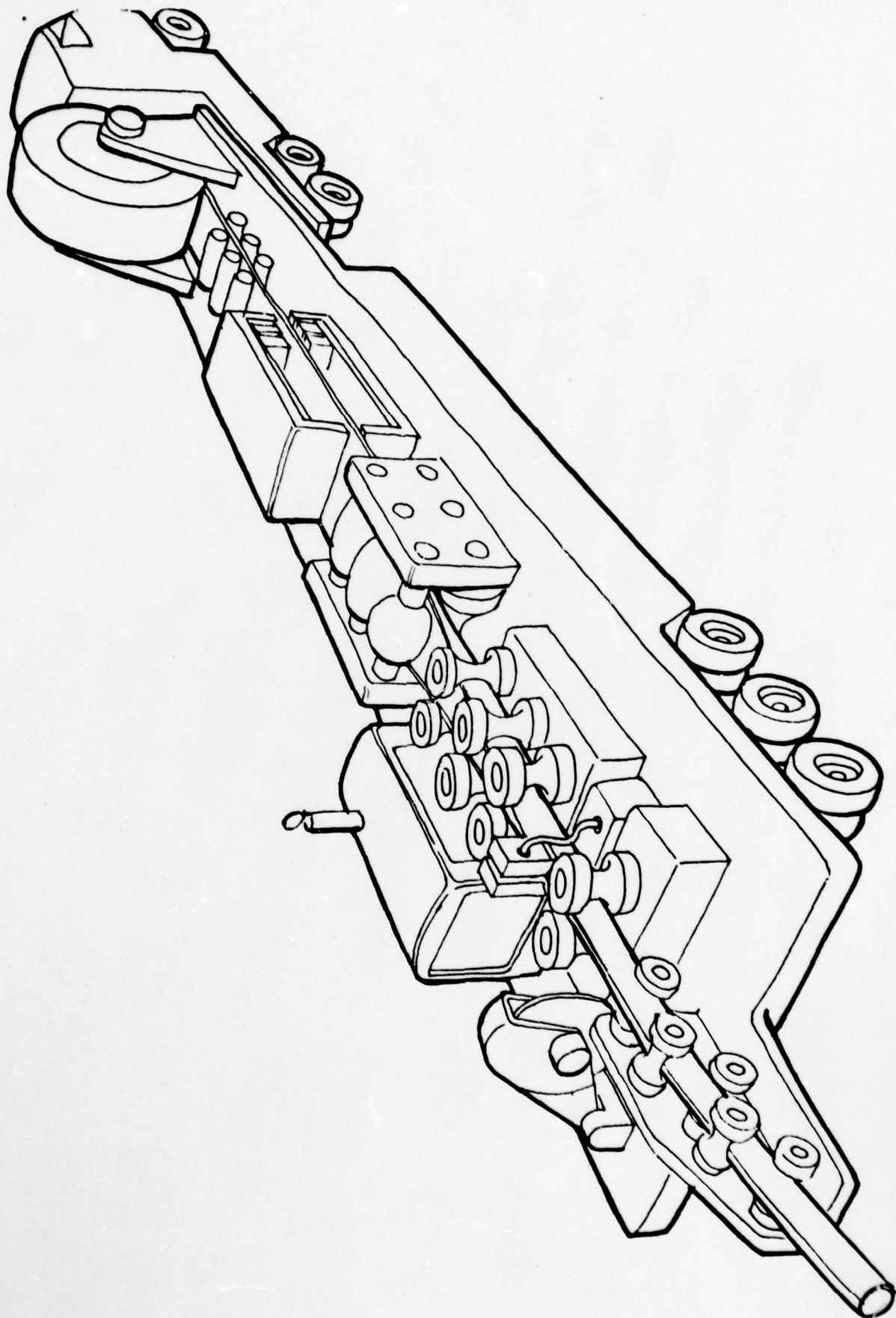

CHAPTER 9

DESCRIPTION AND ECONOMIC ANALYSIS OF MECHANIZED PIPELAYING SYSTEM

9.1 DESCRIPTION OF SYSTEM

1. Introduction

The concept of a mechanized pipelaying system involves the use of machine to align and couple twenty foot sections of pipe. The sections are transported to location and the machine is either self-loading or loaded by forklift.

This concept was the highest scoring concept in the Phase I Analysis and has been considered as a rapid pipeline installation alternative by the Army. Before procurement of such a system can be made, the machine and a joint appropriate for mechanized pipelaying *must be developed*. Currently available joints are not appropriate. However, it is not anticipated that the development of the joint and machine pose a serious problem.

This chapter presents descriptions and sketches of typical joints and pipelaying concepts, plus the life-cycle cost analysis of the system.

2. Overview of the System

● Sizing the System

The pipeline system comprises one 85 mile section of 8" pipe and two branch lines of 17 miles each of 6" pipe. The pipe is a lightweight steel tubing in 20 foot lengths with bell and spigot joints which are self-locking at assembly. The pipeline is laid by a traveling machine which automatically feeds each section of pipe from a self contained supply to an assembly mechanism which joins that section to the preceding section by pushing the ends together until the joint automatically locks. The machine moves continuously at a rate of approximately 1 foot per second, leaving the joined sections of pipe on the ground behind it.

Two machine concepts were considered. Either one is capable of making the bell and spigot joints when pushed into position. For the first concept, when equipment is stopped, it is capable of

reloading itself from a supply by lifting, moving, and lowering an 8' x 8' x 20' package of pipe into a position on its bed for processing. It feeds pipe from the bottom layer, one piece at a time, to a pushing device for making the joints. For this concept, the only additional vehicles needed are tractor-trailers.

A second concept involves a fork lift truck for machine supply. Thus, fork lift trucks as well as tractor trailers would be required. The two concepts are depicted in Figures 9-1 and 9-2. Typical fork lifts are depicted in Figure 9-3. For the purposes of the mission, the concept utilizing fork lifts was chosen for life cycle cost analysis.

One of the important considerations in the costing of the pipelaying operation is the number of machines required to meet the thirty kilometer per day pipelaying design goal. To determine this requirement, the machine time for pipeline installation was computed, based on the parameters in Chapter 6 and an estimated 20 seconds to connect each joint:¹⁶

8" Pipe	
Pipe sections per load ¹⁷	100
Net length per section	19.5 ft.
Pipe laid per load	1950 ft.
Loads required for 85 miles	230
Time to lay load at 20 sec/joint	33.3 minutes
Time to reload machine	8.0 minutes
Additional maneuvering time	<u>2.0 minutes</u>
Total time per load	43.3 minutes
Machine time to lay 85 miles	166 Hours

¹⁶ In order to reduce the total number of required pipelaying machines to two (i.e., 1.5 operating machines and 75% availability) the joint connection time must be reduced to about 12 seconds, a time we believe would be difficult to maintain in practice.

¹⁷ It is assumed that the effective pipe length is slightly reduced to account for the complexity of the joint

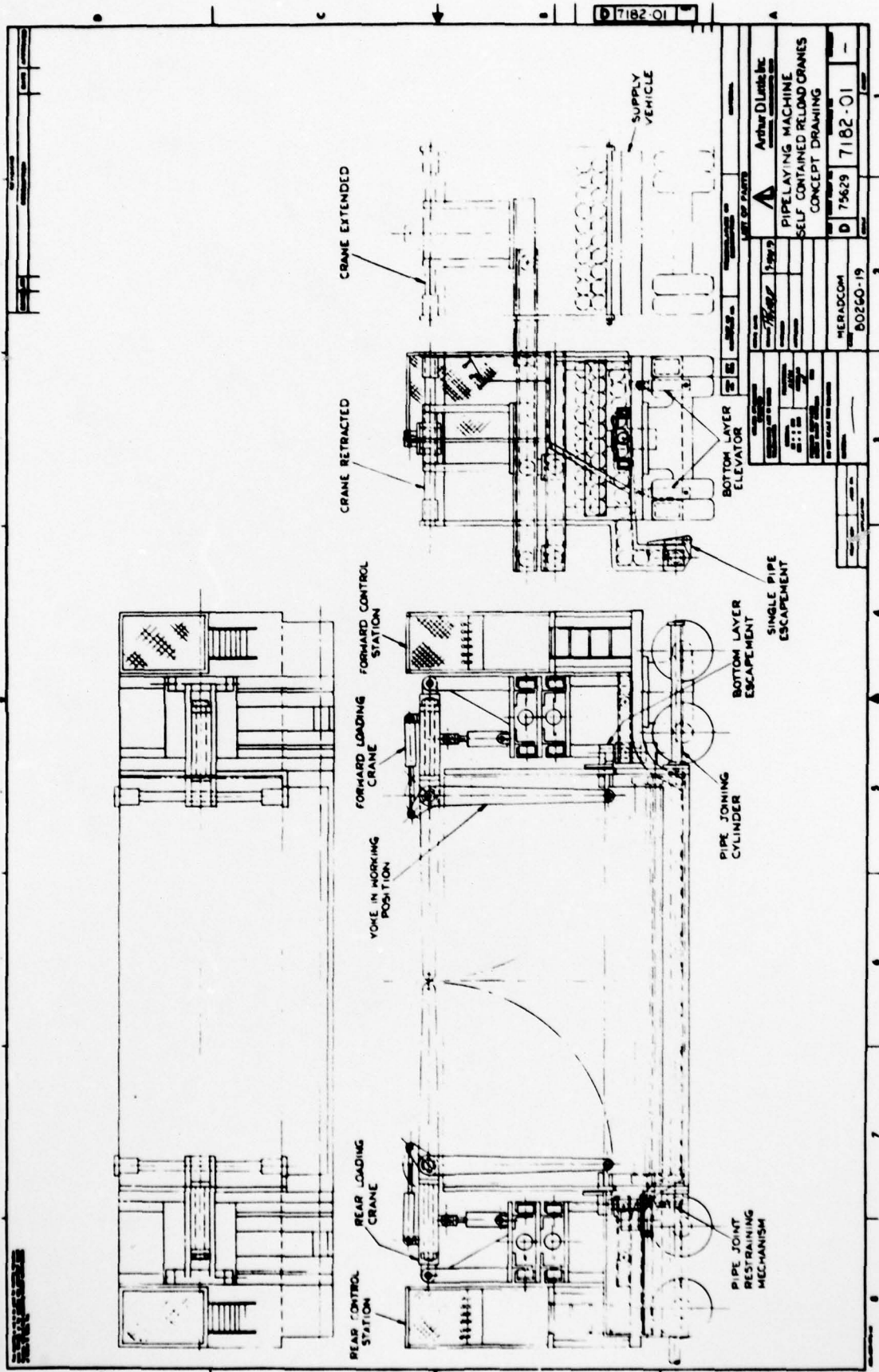

FIGURE 9-1

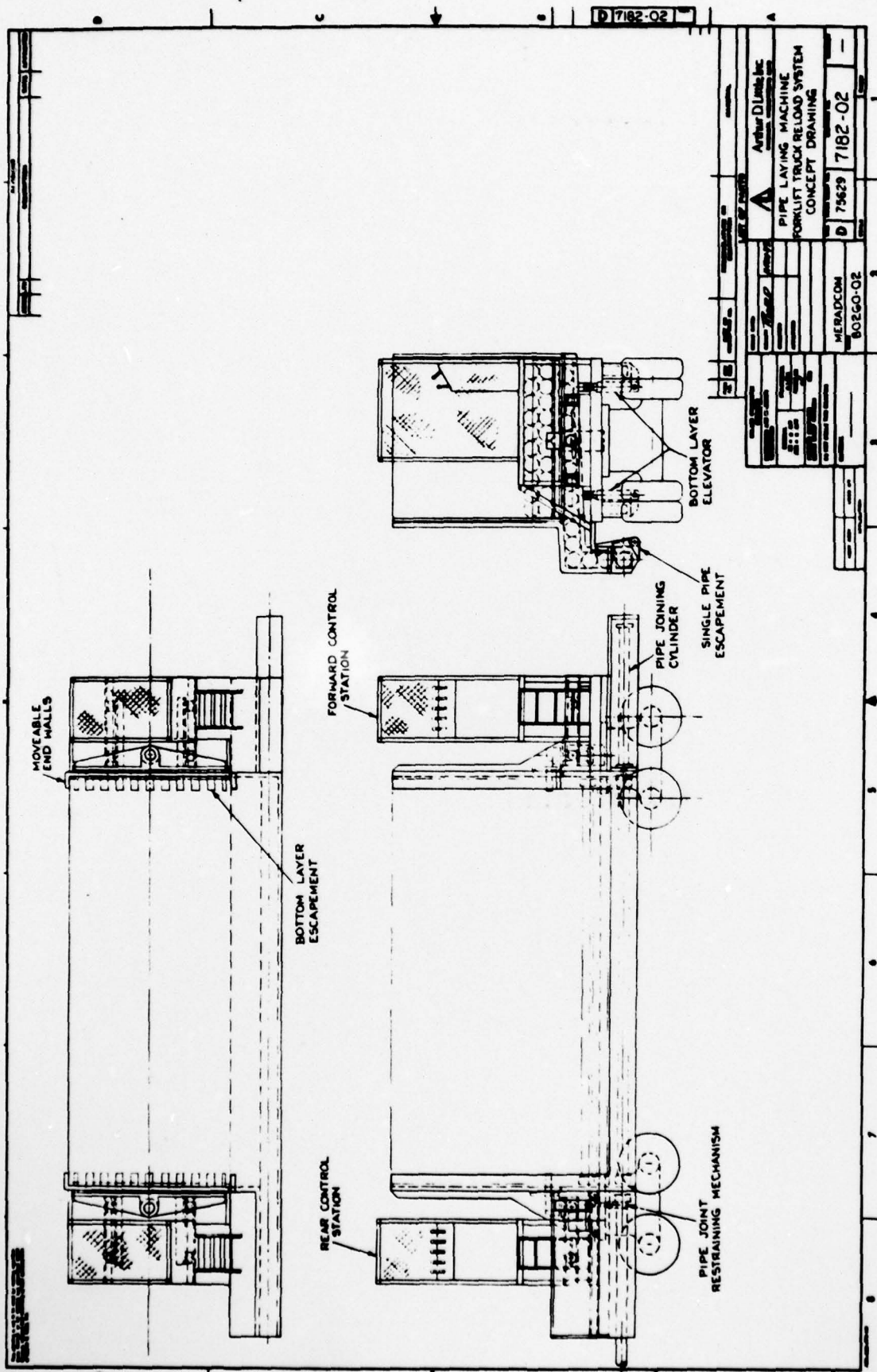

FIGURE 9-2

FIGURE 9-3
TYPICAL FORK LIFTS

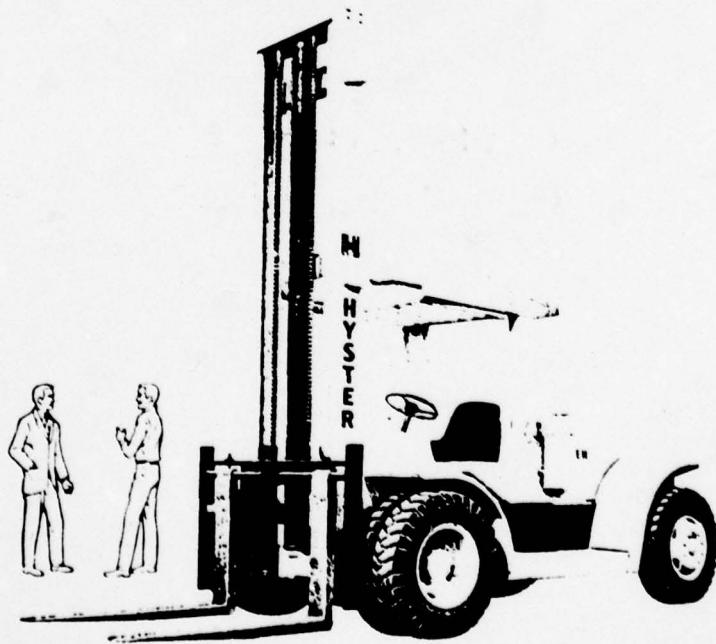
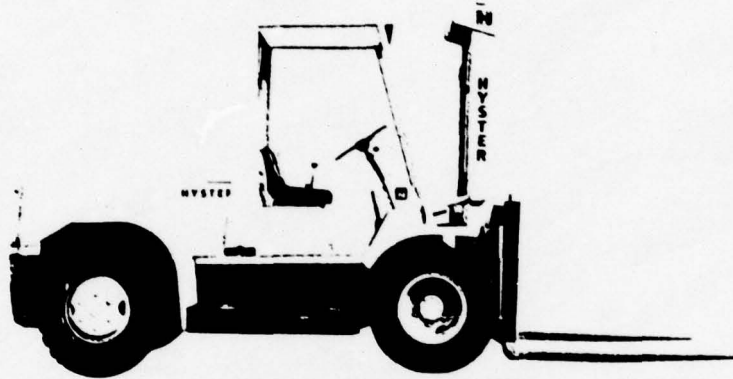
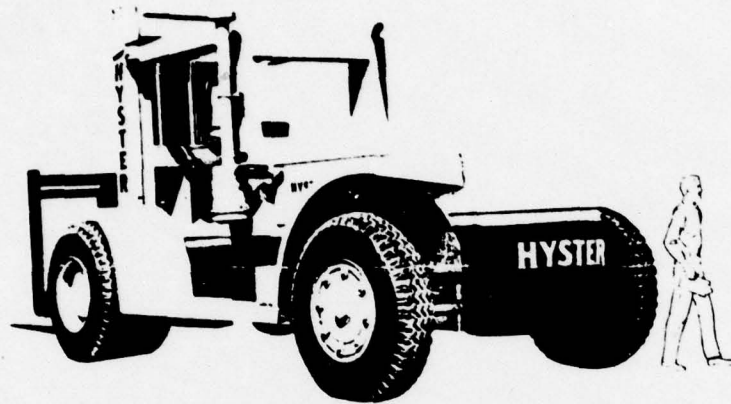

FIGURE 9-3



6" Pipe	
Pipe sections per load	169
Net length per section	19.5 ft.
Pipe laid per Load	3296 ft.
Loads required for 34 miles	55
Time to lay load at 20 sec/joint	56.3 minutes
Time to reload machine	8.0 minutes
Additional maneuvering time	<u>3.5</u> minutes
Total time per load	67.8 minutes
Machine time to lay 34 mi	62 hours

Total machine time required = 228 hours

Since the time available at 30 km or 18.6 miles per 20 hour day = $(119 \div 18.6) 20 = 128$ hours, two pipe laying machines are required, making available a total of 256 machine hours during the time allotted to lay the pipeline. This does not provide much margin for down time, so a third machine should be added. This also provides a necessary margin of reliability, and three machines were assumed throughout the analysis.

One other type of concept was considered. For this third concept, re-loading is performed without stopping. This increases the available pipe laying and can reduce the number of machines required to two. During the reload operation both vehicles cover an area about 32 feet long, 20 feet wide as they move in unison at a rate of 2 feet per second. The device is about 3 feet higher than Concept 1 so that pipe in the pipe-layer can feed continuously during reload cycle. This device is more complex and the cost of a pipelayer might be 25% more. Three or four additional men are required during the reload cycle. The first two concepts were judged to be more appropriate.

Once the pipeline system is installed, it operates at a maximum pressure of 500 psi in the 8" section and 600 psi in the 6" branches. The delivery rate is 35,000 barrels per 20 hour day of diesel fuel having a specific gravity of .8448 and a kinematic viscosity of 3.85 centistokes at 60°F. The pressure differential is 480 psi in the 8" line and 580 psi in the 6" branches; nine pumping stations are required in the 85 mile section of 8" pipe, and 2 pumping stations are required in each 17 mile leg of 6" pipe.

- Alternative Joint Concepts

As noted previously, use of a pipelaying machine would require development in new pipe joints. Existing joints would not be appropriate. We have conceived several joints that might be appropriate. The concepts and accompanying figures are presented below.

AD-A074 297

LITTLE (ARTHUR D) INC CAMBRIDGE MASS
SYSTEMS ANALYSIS OF METHODS FOR INSTALLING FUEL TRANSPORT SYSTEM--ETC(U)
JUN 79 D B ROSENFELD, R H BODE, H H LOEFFLER DAAK70-77-D-0024
ADL-80260-19

F/G 15/5

UNCLASSIFIED

NL

2 OF 2
AD
A074297



END
DATE
FILMED
10-79
DDC

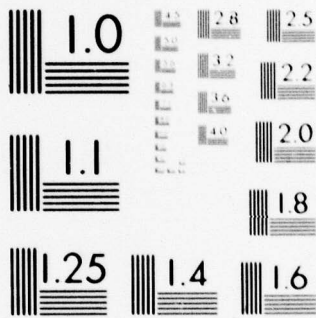

MICROCOPY RESOLUTION TEST CHART
 NATIONAL BUREAU OF STANDARDS-1963-A

Assembly

Assembly

The male and female ends are joined by inserting the male end of the male fitting into the female fitting. The locking fingers of the male fitting are forced open by an external force on the female fitting. The two sections are pushed together until the locking fingers are in place behind the internal locking shoulder of the female fitting.

Assembly

The sections of pipe are joined by inserting the male end of the male fitting into the female fitting of the other. The locking fingers of the male fitting are forced open by an external force on the female fitting. The two sections are pushed together until the locking fingers are in place behind the internal locking shoulder of the female fitting.

Disassembly

To disassemble a joint, the threaded ring is turned by a special wrench, forcing the wedging ring against the tapered ends of the fingers of the locking ring. This forces the locking fingers to open and disengage the locking shoulder, permitting the two sections of pipe to be pulled apart.

Advantages

- Easy assembly excellent
- Excellent adaptability for automated assembly
- Very good joint stability
- Sealing surface of male end fully protected by locking ring against accidental damage
- Internal gasket well protected against damage
- Easy disassembly for repair or reuse

Disadvantages

- Locking ring costly to make
- Latching fingers vulnerable to damage

Estimated Procurement Cost

- 6" = \$50-75
- 8" = \$80-120

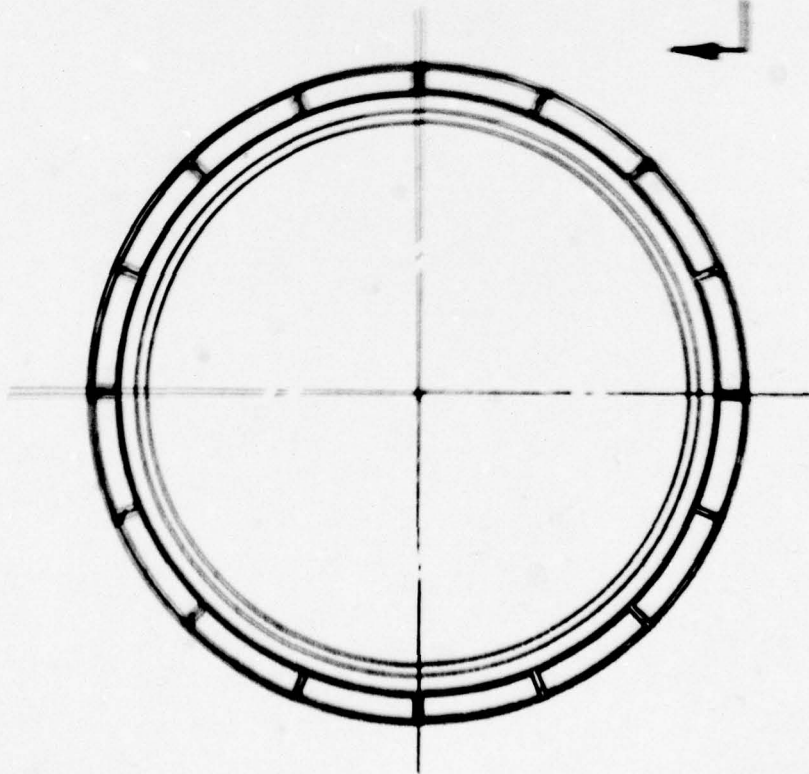
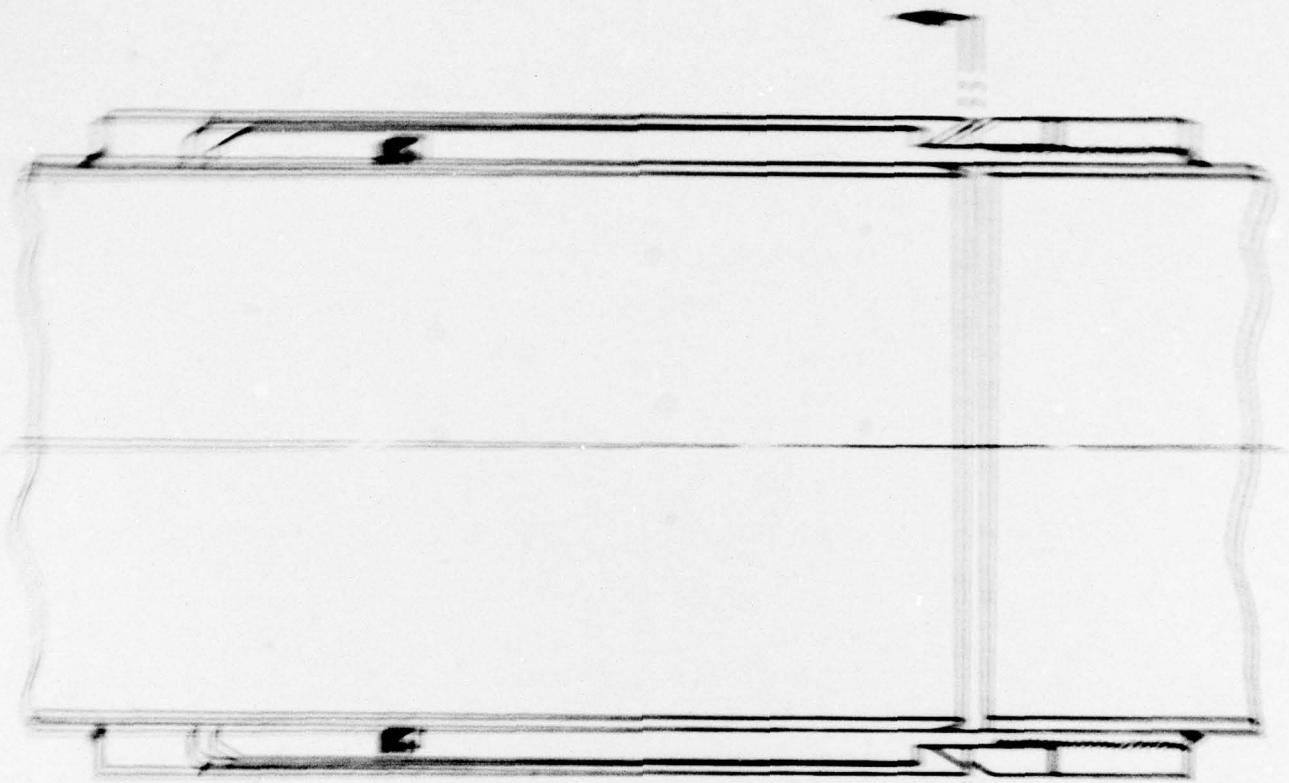
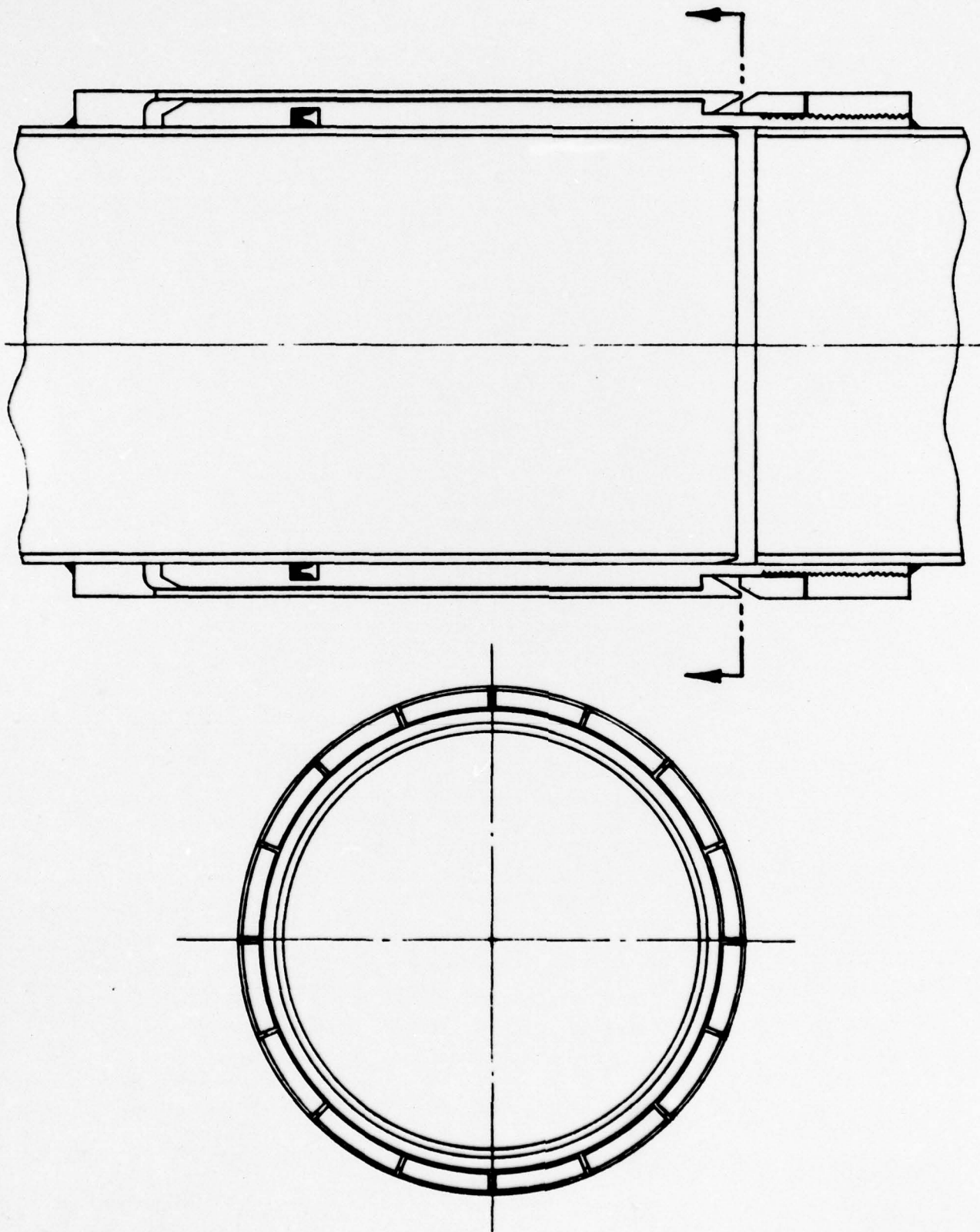

FIGURE 9-4
COUPLING CONCEPT NO. 1



The cost does not include items welded to ends of pipe, which is assumed to be the same cost as end preparation of present commercially available pipe.

● Concept No. 2 (Figure 9-5)

Description

Each length of pipe has identical fittings permanently attached to both ends by welding. Each fitting has an external sealing surface near the end and a locking shoulder near the point of attachment to the pipe. An external sealing ring containing two gaskets in internal grooves surrounds the ends of two adjoining sections of pipe. A split locking ring having latching fingers on both ends (similar to the fingers of the locking ring in Concept 1) surrounds the sealing ring. The latching fingers seat behind the locking shoulders of the fitting to hold the joint together. The two halves of the split locking ring are fastened together by bolts and nuts.

Assembly

Before transportation to the pipelaying site, the gaskets are assembled in the sealing ring, and the two halves of the locking ring are fastened in place around the sealing ring. To join two sections of pipe, the ends are first aligned. In the case of manual assembly, this would be done by a temporary internal aligning member pulled through the pipe to each joint in sequence. The ends of the two sections are then inserted into the ends of the locking ring, forcing the latching fingers to open, and then into the sealing ring until the latching fingers snap in place behind the locking shoulders.

Disassembly

To disassemble a joint the two halves of the locking ring are separated, by removing the two nuts, and removed from the joint. The ends of the pipe sections may then be withdrawn from the sealing ring.

Advantages

Ease of assembly very good
Very good adaptability for automated assembly
Sealing surface of fitting somewhat protected by larger diameter adjacent portion of fitting
Internal gasket well protected against damage
Easy disassembly for repair or reuse

FIGURE 9-5
COUPLING CONCEPT NO. 2

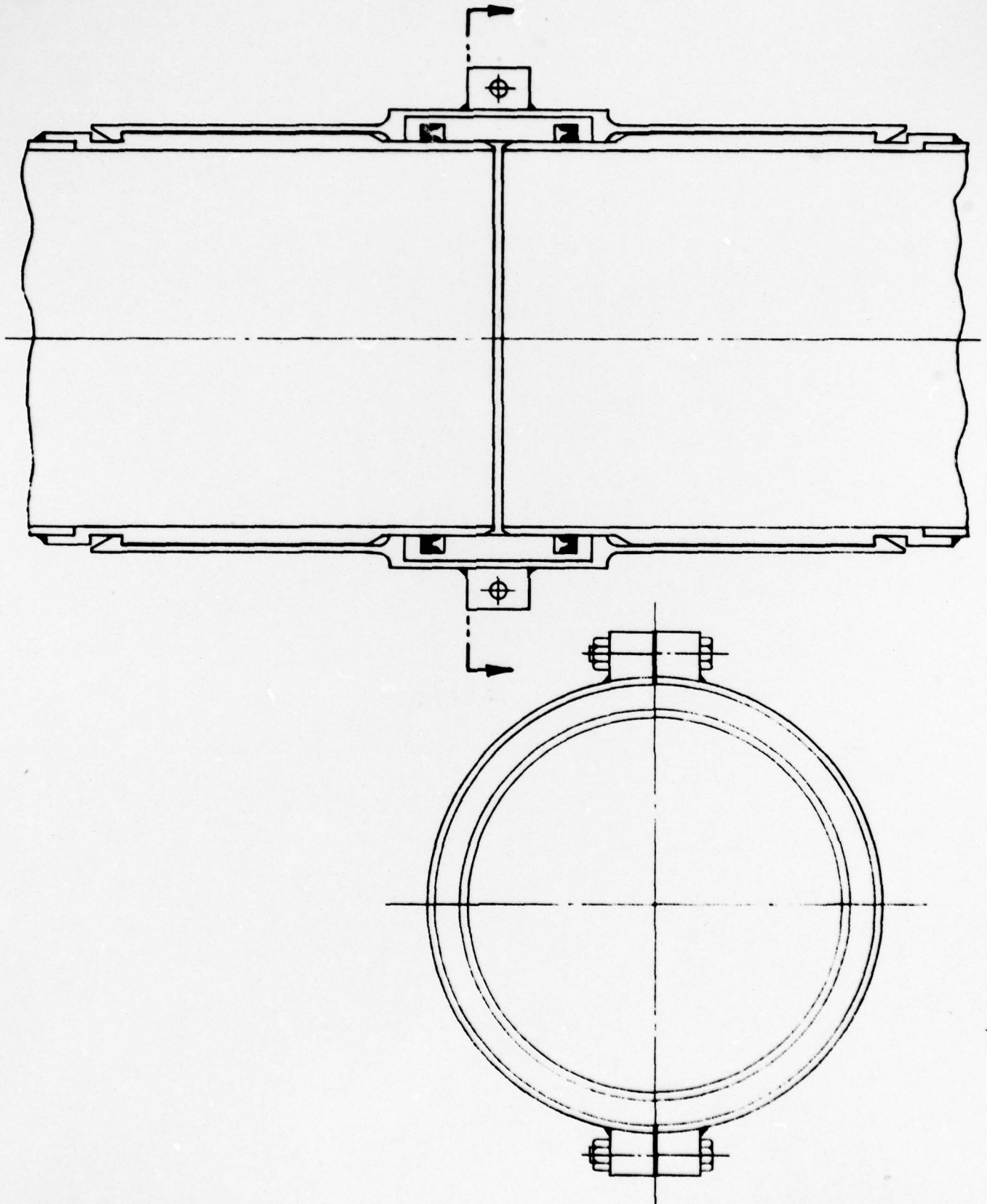

Disadvantages

Joint stability questionable
Locking ring costly to make
Two gaskets increase possibility of leaks

Estimated Procurement Cost

6" - \$80-120
8" - \$120-180

The cost does not include items welded to ends of pipe, which is assumed to be the same cost as end preparation of present commercially available pipe.

- Concept No. 3 (Figure 9-6)

Description

Each length of pipe has a locking shoulder near one end and a female fitting has an internal groove containing a lip-type gasket which forms a seal against the outside surface of the male end of the adjoining section of pipe. A two-piece locking ring surrounds the locking shoulder of the male end of the pipe and a shoulder at the end of the female fitting, locking the two sections of pipe together. The two halves of the locking ring are held in place by their projecting ends, which are a snap fit over the outer chamber of the locking shoulders.

Assembly

Two sections of pipe are joined by inserting the male end of one in the female fitting of the other until the end of the female fitting contacts the locking shoulder. The two halves of the locking ring are then snapped over the two shoulders, locking the two sections together.

Disassembly

To disassemble a joint, the halves of the locking ring may be driven using a hammer and a punch inserted in the gap at the end of the projecting tab. Alternatively, a special tool could be inserted in that gap and opened to force the two halves of the ring apart and off the joint.

Advantages

Ease of assembly good
Good adaptability for automated assembly
Very good joint stability
Sealing surface of male end somewhat protected by larger diameter of adjacent shoulder

FIGURE 9-6
COUPLING CONCEPT NO. 3

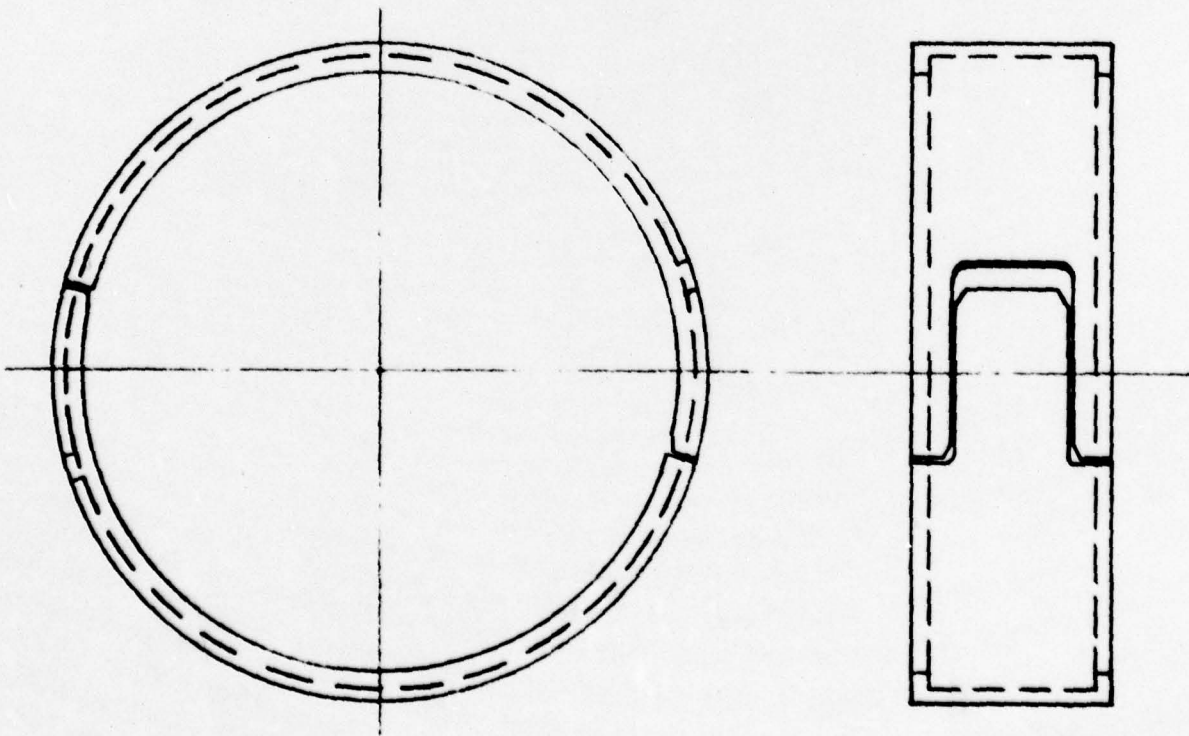
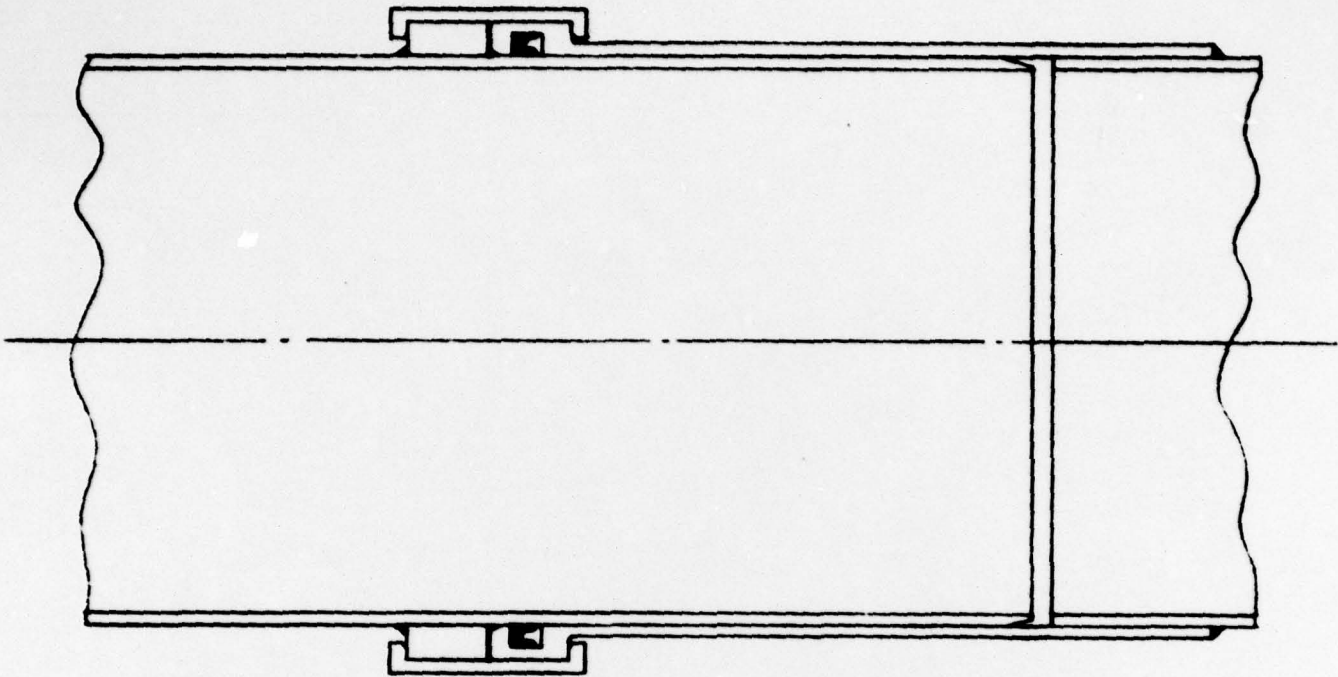

Internal gasket well protected against damage
Easy disassembly for repair or reuse

Disadvantages

More complicated assembly procedure than Concepts 1 or 2.

Estimated Procurement Cost

6" - \$14

8" - \$22

The cost does not include items welded to ends of pipe, which is assumed to be the same cost as end preparation of present commercially available pipe. The seal is smaller and locking ring is more complex. Therefore, the cost should not be higher than those of presently available couplings.

- Alternative Construction (Concept 3a)

The locking ring can be replaced by a bolted two piece clamp ring similar to the one used in the present standard joint. However, one half of the clamp ring would have tapped holes, eliminating the nuts used with the present ring. Manual assembly and disassembly would be somewhat slower than for Concept 3 but the joint would still be adaptable for automated assembly using mechanized feeding and torquing of the bolts. Joint security would be improved over Concept 3.

- Concept No. 4 (Figure 9-7)

Description

Each length of pipe has identical fittings permanently attached to both ends by welding. Each fitting has an external sealing surface near the end and a locking shoulder near the point of attachment to the pipe. An external sealing ring containing two gaskets in internal grooves surrounds the ends of two adjoining sections of pipe. A two-piece locking ring surrounds the sealing ring and engages the locking shoulders to hold the joint together. The two halves of the locking ring are held in place by a spring latch on one end of each half, which engages a slot in the adjacent end of the other half.

Assembly

Before transportation to the pipelaying site, the two gaskets are assembled in the sealing ring. To join two sections of pipe, the ends are first aligned. In the case of manual assembly, this would be done by a temporary internal aligning member pulled through the pipe to each joint in sequence. The ends of the two sections

FIGURE 9-7
COUPLING CONCEPT NO. 4

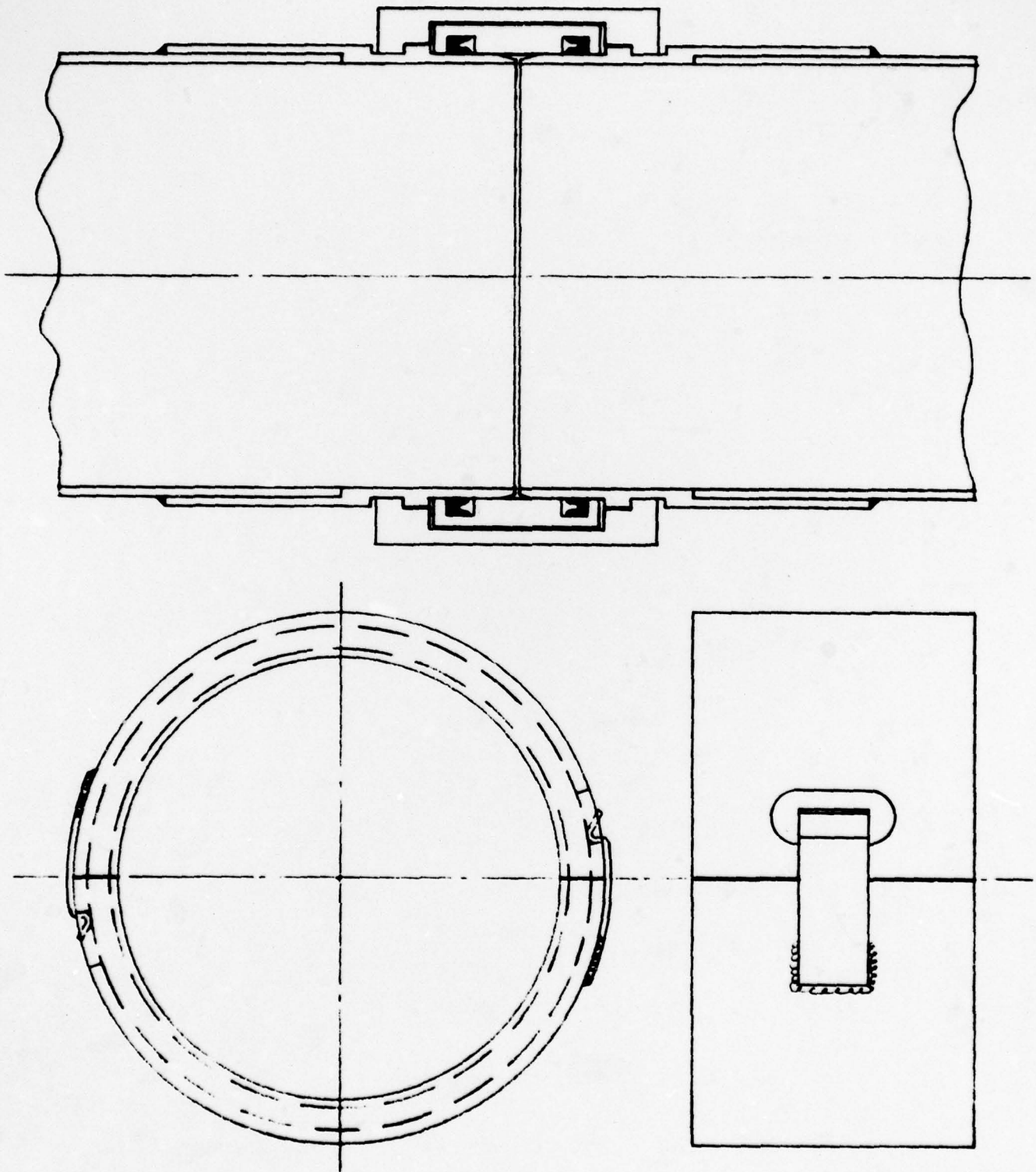

are then inserted into the locking ring and pushed together. The two halves of the locking ring are then placed over the sealing ring and the locking shoulders, and snapped together to lock the joint.

Disassembly

To disassemble a joint, the spring latches are pried up using a large screw-driver or special tool, and the two halves of the locking ring removed.

Advantages

Sealing surfaces of fittings somewhat protected by adjacent locking shoulders
Internal gaskets well protected against damage
Easy disassembly for repair or reuse.

Disadvantages

Ease of assembly only fair
Adaptability for automated assembly is only fair because of increased number of parts
Joint stability questionable

Estimated Procurement Cost

6" - \$25-35
7" - \$40-55

The cost does not include items welded to ends of pipe, which is assumed to be the same cost as end preparation of present commercially available pipe.

● Alternative Construction

The locking ring can be replaced by a bolted two-piece clamp as described under alternative construction for Concept 3. This would make manual assembly and disassembly slower, but would still be adaptable for automated assembly and would provide a more secure joint. The joint would be similar to a presently available joint, but assembly would be easier and quicker because of the gaskets being pre-assembled within the sealing ring.

9.2 LIFE CYCLE COST ANALYSIS FOR FORK LIFT OPTION

1. Research and Development Program and Subcycle

Research and development effort is required both for the pipelaying machine and the compatible joint concept, and this is tabulated as follows:

- Machine

1. Initial Design		
12 Man months @ \$10K		\$120K
2. Stress Analysis		
4 Man months @ \$10K		40K
3. Redesign		
6 Man months @ \$10K		60K
4. Details		
36 Man months @ \$5.0K		180K
5. Component Specs		
4 Man months @ \$10K		40K
6. Procurement and Expediting		
3 Man months @ \$10K		30K
7. Assembly and Testing		
12 Man months @ \$6K		72K
8. Modification to Design, Details and Specs		
9 Man months @ \$6K		<u>54K</u>
		\$596K

- Design, Development, and Tooling for Production of New Pipe Joint

1. Initial Development-Conceptual		
10 Man months @ \$10K		124K
4 Man months @ \$6K		
2. Advanced Development for Validation		
8 Man months @ \$10K		104K
4 Man months @ \$6K		
3. Initial Testing		
4 Man months @ \$6K		24K
4. Prototype Development and Testing		
4 Man months @ \$10K		76K
6 Man months @ \$6K		

5. Production Engineering Planning

6 Man months @ \$10K

60K
\$388K

Total

\$984K

2. Procurement Program and Subcycle

As in the baseline system, there is a great deal of uncertainty in the cost of pipeline sections. This uncertainty is even further increased by the fact that a new joint must be developed. In the economic analysis, the figure of \$373 per 20 section for 8" pipe and \$297 per section per 20' section for 6" pipe are again used. However, in Chapter 11, lower prices are utilized for sensitivity analysis.

In view of this the procurement cost for pipe, couplings and pump stations is identical to the baseline system and is \$15,064.8K. The other part of the procurement costs are the pipelaying machine and fork lift costs: The estimates for these costs are as follows:

Pipelaying machine cost detail

1. Chassis, 4 axles and wheels	\$125K
2. Drive Train	30K
3. Tandem Steering	35K
4. Hydraulic Power Supply	10K
5. Two lower layer escapements - structure	5K
6. Two lower layer escapements - hydraulics cylinders, valves, tubing, fittings	4K
7. Two lower layer elevators - structure	4K
Two lower layer elevators - hydraulics cylinders, valves, tubing, fittings	4K
8. Two single pipe escapements - structure	4K
Two single pipe escapements - hydraulics cylinders, valves, tubing, fittings	4K
9. Pipe joining mechanism - structure	8K
Pipe joining mechanism - hydraulics cylinders, valves, tubing, fittings	5K
10. Pipe load containment structure	8K
	<u>\$246K</u>

Assembly and Test Costs

1. Assembly - entire pipelayer structure 12 Man months @ \$6K	\$72K
2. Assembly - entire pipelayer hydraulics 6 Man months @ \$6K	36K
3. Testing and adjusting hydraulics 2 Man months @ \$6K	12K
4. Cycling and modifying system under loads 6 Man months @ \$6K	36K
5. Field Test and Modification 6 Man months @ \$6K	36K
6. Purchased Materials - Modifications	<u>10K</u> \$202K

Thus, the total cost for each machine is estimated to be \$448K, and the total for the three machines is, including 15% spares is \$1545.6K. The cost per fork lift (e.g., Clark Model 800) is \$207K and hence the total for 3 fork lifts, plus 15% spares is \$714.2K. Thus, the total procurement cost is \$17,324.6.

3. Transportation Subcycle - Manufacture to CONUS Depot or Unit

- Pipe, stations, and couplings would run \$452.2K as based on analysis in Chapter 6.
- In addition, three pipelaying machines at 360 tons each and three fork lifts at 55 tons each with 15% contingency spares at \$96/ton would cost \$137.4K.
- Total cost of transportation from manufacture to CONUS Depot cost is \$589.6K.

4. Support Readiness Subcycle

Note that the system is similar to the manual system with the addition of fork lifts and pipelaying machines. Thus, the support readiness cost is equal to the total support readiness cost for the baseline system in Chapter 6 with the addition of operating costs for one fork lift and pipelaying machine and transportation for one pipelaying machine.

- Total support readiness for baseline system = \$4,774.6K
- Pipelaying machine and fork lift transport cost =
415 tons x 10 years x 2 trips/year x \$96/ton trip = \$796.8K
- Fork lift and pipelaying machine operating costs are estimated to be about \$53.9 per hour,¹⁸ or
10 years x 6 companies x 2 weeks/year x 40 hours/week x \$53.9/hr = \$258.7K.
- Total support readiness costs are \$5,830.1K.

5. Transportation Subcycle CONUS Depot or Unit to Theater POE Depot

The total cost is the baseline system cost (\$1897.7K) plus the transportation cost of the three machines plus fork lifts at \$403 per ton, (3 machines x 415 tons x 1.15 spares factor x \$403 = \$577.0K) and the total cost is \$2474.7K.

6. Lay Mission Pipeline at a Rate of 30 km per 20 Hour Day

The three pipelaying machines operate simultaneously on different sections of the pipeline. Each machine is serviced by a fork lift truck. The pipe is hauled from the POE to the machines by tractor-trailers, 2 machine loads of pipe per trip. The average hauling distance is 85 miles round trip for 8" pipe and 187 miles round trip for 6" pipe, at an average speed of 15 mph. The tractor-trailer combinations are the same as used for the manual system in Chapter 6.

The mission takes about 6.4 days, although the time may be less since, theoretically, three machines when operating provide excess capacity. Each machine has a crew of three men, and two additional men walk along side and inspect the laid pipeline. The procedure should not require the use of a full crew.

Tractor-trailer requirements for hauling pipe are listed in Table 9-1. Table 9-2 lists tractor-trailer requirements for hauling pumping stations. Thus, the number of tractor-trailer days is 61. The cost of the number of drivers is based on 82 to be consistent with the assumption that 25% of the tractor-trailers will not be operable at any time. Given a 6.4 day mission, 13 tractor-trailers and 26 drivers are required. The costs for the subcycle are therefore as follows:

¹⁸ Based on the Cost Reference Guide for Construction Equipment, 1979 Edition, for a fork lift plus a heavy duty off the road vehicle. The cost of the latter was increased by 50% to reflect the complexity of the pipe-laying machine.

TABLE 9-1

TRACTOR-TRAILER REQUIREMENTS FOR HAULING PIPE

	<u>8" Pipe</u>	<u>6" Pipe</u>	<u>Total</u>
Average Round Trip, Miles	85	187	-
Hauling Time at 15 mph, hours	5.7	12.5	-
Loading Time per Trip, hours	.13	.13	-
Unloading Time per Trip, hours	.13	.13	-
Waiting Time per trip, hours	.5	.5	-
Total Time per Trip, hours	6.5	13.3	-
Trailer Loads Required ¹⁹	115	28	143
Tractor-Trailer Days Required	38	19	57

TABLE 9-2

TRACTOR-TRAILER REQUIREMENTS FOR HAULING PUMPING STATIONS

	<u>8" Pipe</u>	<u>6" Pipe</u>	<u>Total</u>
Average Round Trip, Miles	85	187	-
Hauling Time at 15 mph, hours	5.7	12.5	-
Loading and Unloading Time, hours	2.0	2.0	-
Total Time per Trip, hours	7.7	14.5	-
Trailer Loads Required	5	2	8
Tractor-Trailer Days Required	2	2	4

¹⁹ Two loads per trailer are assumed as in Table 6-7.

- Operation and Maintenance

At an operating and maintenance cost of \$10.43 per hour
(See Chapter 6) the tractor/trailer cost is

$$61 \text{ tractor/trailer days} \times 20 \text{ hours/day} \times 10.43/\text{hour} = \$12.7\text{K}$$

- Operating Costs

Estimating operating costs for each machine and fork lift at
about \$53.9 per hour (See Support Readiness Subcycle), the
machine and fork lift cost is

$$2 \text{ operating machine sets} \times \$53.9/\text{hour} \times 6.4 \text{ days} \times 20 \text{ hours/day} \\ = \$13.8\text{K}$$

- Total O&M Costs are \$26.5K

- Manpower Costs

Assuming the cost of one company, the pipelaying cost is

$$122 \text{ men} \times 6.4 \text{ days} \times \$14,600/\text{man year} \div 365 \text{ days/year} = \$31.2\text{K}$$

The 26 drivers for the tractor trailers cost

$$26 \times 6.4 \times \$16,033 \div 365 = 7.3\text{K}$$

and the total manpower cost is \$38.5K

- Total Cost To Install System

O&M	\$26.5K
Manpower	<u>38.5K</u>
Total	\$65 K

7. Operate System for 6 Months at 35,000 Barrels Per 20 Hour Day

This cost is identical to the baseline system and is equal to \$2,796.8.

8. Summary of Life Cycle Cost for Mechanized System

Research and Development	\$ 984.0K
Procurement	17,324.6K
Transportation - Manufacture to Depot	589.6K
Support Readiness	5,830.1K
Transportation to Theater	2,474.7K
Install System	65.0K
Operate System	<u>2,796.8K</u>
Total Life Cycle Cost	\$30,064.8K

CHAPTER 10 - DESCRIPTION AND ECONOMIC ANALYSIS OF COLLAPSIBLE HOSE CONCEPT

10.1 INTRODUCTION

The concept envisioned at the end of Phase I was a flexible, collapsible, low-to-medium-pressure hose. This concept has become more attractive in the past few years because of the possibility of increasing hose operating pressure values from 150 psi to 300 psi. There is no question that such medium pressure hose systems entail more development risk than any of the other concepts. However, our discussions with experts and manufacturers have led to the conclusion that the system is feasible.

Some of the issues involved in developing and using such a hose are presented in Section 10.2. Section 10.3 presents the life cycle cost analysis. One of the advantages of the hose system (as described in Chapter 3, Section 2, "Collapsible Hose: H3 and H4") is that it can be easily installed. The hose can be layed out continuously from a moving trailer and can be adjusted by a walking two man team.

10.2 USE AND DEVELOPMENT OF HOSE SYSTEM

Collapsible hose (6", 8" in diameter) is fabricated by extruding a thin inner tube of thermoplastic elastomer (e.g., polyester or polyurethane type) and covering with multiple outer jackets of woven high strength yarn or filaments. The woven outer jacket is the primary pressure retaining element. The thin (0.020" - 0.030") inner tube functions primarily as an impermeable channel for the fuels.

Such constructions are currently primarily used for municipal and industrial hose applications. Diameters in use range from 1-1/2" to 6". It may be possible to weave 8" diameter jacketing on the same looms.

Hose couplings have traditionally been made from brass for water service but extruded aluminum couplings have also gained favor because of the considerable weight savings and cost savings resulting from their use.

Maximum working pressures currently achieved are 150 psi; however, it may be feasible to at least double the working pressure limitation through use of:

- higher strength fibers
- double jacketing
- tighter jacket weaves

Abrasion resistance can be improved by dip coating.

The installed pipeline system comprises one 85 mile section of 8" hose and two branch lines of 6" hose each 17 miles long. The hose is fabricated in sections 100 feet long, which are joined together by extruded aluminum couplings before flaking in 8' x 8' x 20' containers that serve as shipping storage, and pipeline laying containers. The containers hold 10,000 feet of 6" hose and 7,500 feet of 8" hose, with separators between layers of flaked hose. It should be possible to use the containers for shipping to the distribution point and to use the same containers as part of the field laying system.

The hose system operates at a maximum pressure of 300 psi and a delivery rate of 35,000 barrels per 20 hour day of diesel fuel having a specific gravity of .8448 and a kinematic viscosity of 3.85 centistokes at a temperature of 60°F. The pressure differential in the pumping stations is 280 psi; 16 pumping stations are required in the 85 mile line of 8" hose, and 4 pumping stations are required in each 17 mile leg of 6" hose.

As noted, there is a substantial amount of development risk in the hosing concept. In Figure 10-1 we present how the R/D program relates to the pipeline life cycle. An initial and advanced product development program as well as an engineering development/prototype manufacture phase is required. The timing for these phases of the R/D program is shown in the figure.

The overall objectives of the initial product development program are to:

- Demonstrate maximum working pressure possible using currently available materials and manufacturing methods.
- Design hose using most promising approaches.
- Build/test experimental models.

Other major areas to be explored during this initial product development program are:

- Premeability
- Cut-through resistance
- Effects of long-term (10 year) storage
- Environmental resistance (ultraviolet, cold, heat, etc.)
- Long-term exposure testing
- Abrasion resistance
- Details of construction (e.g., adhesive between tube and jacket, outer protective coating)

FIGURE 10- 1

TIME REQUIREMENTS FOR FLEXIBLE PIPELINE R&D PROGRAM

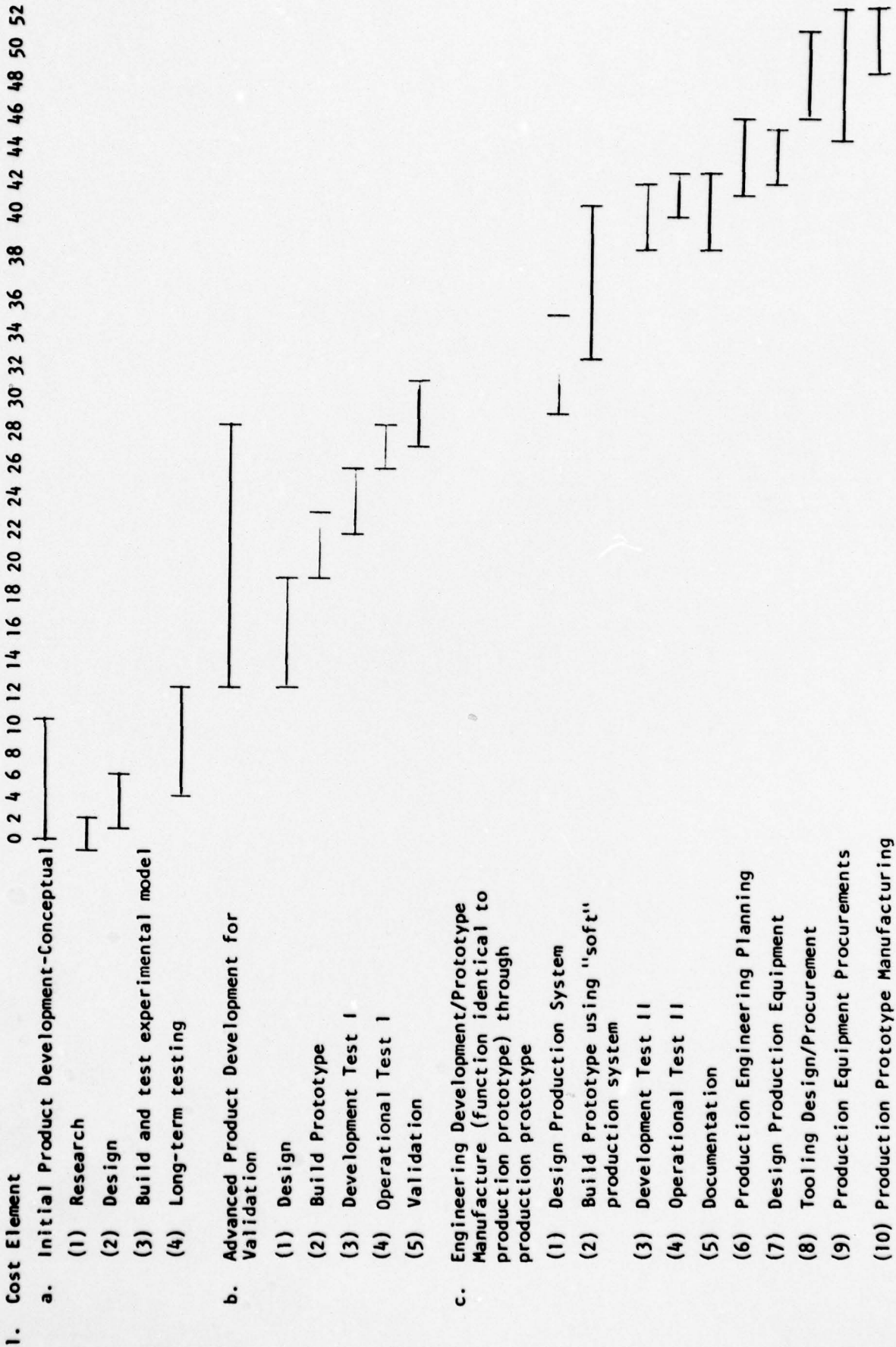

- Practical manufacturing lengths
- Evaluation of suitability of current coupling designs
- Estimated manufacturing rate
- Manufacturing economics
- Capital investment requirements
- Effects of physical factors on pipe performance (e.g., stretching (~8%) during filling, effect of fluid weight on coupling retention, folding during storage)

At the conclusion of the initial product development program it is anticipated that the contractor(s) will have demonstrated the feasibility/unfeasibility of using flexible hose constructions for the proposed application, the upper practical limit of working pressure, defined the requirements for changes in manufacturing methods, estimated manufacturing costs and production rates and established test procedures. Experimental models of the most promising hose construction will have been made and tested and the results evaluated.

The overall objective of the advanced product development program is to achieve validation of the product concept by the Army. This will be achieved by designing, building, and testing prototype products of the most promising configuration(s) as determined in the initial product development program described above. We estimate that five or ten 50' or 100' sample lengths will be required for development and operational testing. These samples will be built using available production equipment or simply modifications thereof. No extensive equipment purchase is envisioned.

In a final engineering development/prototype manufacture program, the following objectives would be accomplished.

- Carry out the design and engineering necessary to create a satisfactory production system.
- Produce and test prototype samples using a "soft" production system.
- Construct a "hard" manufacturing system.
- Manufacture 1-2 miles of production prototype hose for evaluation by the Army.

10.3 LIFE CYCLE COST

As in other chapters, the life cycle cost is computed in accordance with

the mission definition in Chapter 5, complete with the appropriate sub-cycle headings.

1. Research and Development Program and Subcycle

	<u>Cost (\$000)</u>	<u>Time (Mo.)</u>
Initial Product Development	120.0	10
Advanced Product Development	225.0	18
Engineering Development/ Prototype Mfg. and Testing	<u>320.0</u>	<u>24-30</u>
Total	665.0	52-58

The timing of research and development, which most crucial for this alternative, is depicted in Figure 10-1.

2. Procurement Program and Subcycle

Quotations (Rough Price Estimates) by American Biltrite for hosing was \$8.50 per foot for 6" hose and \$12.00 per foot for 8" hose. The present Army cost for 4 inch hose, which operates at 125 psi, is \$7.65 per foot. Consequently, in the final evaluation, we performed a sensitivity analysis and added a contingency factor so that the prices were \$10.00 and \$14.00 per foot for 6" and 8" hose respectively. The analysis in this chapter uses the base American Biltrite estimated cost figures.

• Quantity Requirements

	<u>Cost</u>
6" hose (34 miles = 179,520 feet)	\$1,525.9K
Cost per foot = \$8.50 including fittings	
8" hose (85 miles = 448,800 feet)	\$5,385.6K
Cost per foot = \$12.00 including fittings	
6" hose containers (18 required)	\$ 108.0K
Cost each \$6,000	
8" hose containers (60 required)	\$ 330.0K
Cost each \$5,500	
(The lower cost for 8" hose containers reflects the fact that fewer separators are needed)	
Total Hose and Containers	<u>\$7,349.5K</u>

- Cost Calculation for Pump Station for 8" Hose

$$\text{Cost each} = 45,000 + 64.25P + .089PQ = \$96,983$$

$$P = 300 \text{ psi, } Q = 1225 \text{ gpm (BHP} = 250)$$

From the analysis of the pressure drop based on hose, 16 pump stations are required.

Total cost (K\$) \$1,551.7K

- Cost Calculation for Pump Station for 6" Hose

$$\text{Cost each} = 21,875 + 16.33P + .089PQ = \$43,128$$

$$P = 300 \text{ psi, } Q = 612.5 \text{ gpm (BHP} = 125)$$

From the analysis based on 300 psi hose, 8 pump stations are required.

Total cost is \$ 345.0K

- Total Procurement (K\$)

Hose and Containers \$7,349.5K

Pump Stations for 8" Hose \$1,551.7K

Pump Stations for 6" Hose \$ 345.0K

Total \$9,246.2K

Plus (15% spares) 10,633.1K

3. Transportation Subcycle Manufacturer to CONUS Depot or Unit

<u>Item</u>	<u>Quantity</u>	<u>Wt/Unit(lb)</u>	<u>Total Tons</u>
8" Hose	448,800 ft.	3.0	673.2
6" Hose	179,520 ft.	1.7	152.6
8" Containers	60 units	4150	124.5
6" Containers	18 units	5300(8600) ²⁰	47.7(77.4) ²⁰
Pump Stations for 8" Hose	16 units	18,000	144.0
Pump Stations for 6" Hose	8 units	14,000	56.0
		Total Tons	1227.7
		Cost @ \$96/Ton	117.9K
		Plus 15%	
		Contingencies	135.6K

²⁰For transportation costing, the volume is the limiting factor on containers of 6" hose. The excess in computing the cost on a cube basis is added to the weight of the container and the total charged tonnage is in parentheses.

4. Support Readiness Subcycle

As described in Chapter 5, these costs include transportation, installation and operation of a small hose system for a two week training session for each year during the ten year period. The system includes four containers of 8" hose and (at most) two pumping stations.

- Inventory Holding Costs

None since Depot Costs are not allocated

- Training Costs

These include transportation, operation and maintenance, and manpower costs for the training session.

- Transportation Costs

● Hose (30,000 ft x 3.0 lb)	45.0 tons
Containers (4 x 4150 lb)	8.3
Pumping stations (2 x 18,000 lb)	<u>18.0</u>
Total Weight(x 1.15)	82.0 tons

- Transportation Cost for 10 years at two trips per year and \$96 per ton trip is \$157.4K

- Operation and Maintenance

- Pumping

Station operating cost per hour is \$7.90 based on BHP and is computed as same manner as in Chapter 6. For the 80 hours in the two week period per each of the ten years for the two stations and six companies, the cost is
 $2 \times 10 \times 80 \times \$7.90 \times 6 = \$75.8K$

- Tractor and Trailers

Using the same costs for tractors and trailers as in Chapter 6, but only one tractor-trailer for the operation, the cost is \$50.1K

- Total O&M costs are \$125.9K

- **Manpower Costs**

The manpower costs are the same as for the manual system, and thus totals \$4099.2K.

- **Total training costs are \$4382.5K**

- **System Upgrade and Improvement Costs**

It is assumed that there is no system upgrade or improvement

- **Total support readiness costs are \$4382.5K**

- **5. Transportation Subcycle - CONUS Depot or Unit to Theater POE Depot**

As in Chapter 6, the cost per ton is \$403 and hence the total cost (See 3. Transportation Subcycle Manufacturer to CONUS Depot Unit) allowing for spares is

$$1227.7 \times 1.15 \times \$403 = \$569.0K$$

- **6. Mission: Lay Hose at Rate of 30 km per 20 Hour Day**

The cost of laying the hose system is based on the same truck parameters as the other concepts. These parameters are described in Chapter 6 in the presentation of the life cycle cost of the manual system.

The difference results from the method of installation, which can easily be performed by one company. The hose is hauled in its containers from the POE to the laying site by tractor-trailers, 2 containers per trailer. The average hauling distance is 85 miles round trip for 8" hose and 187 miles round trip for the 6" hose, at an average speed of 15 mph. The hose is installed by laying out continuously from the moving trailer the previously coupled hose at an average rate of 5 mph. The hose line is then walked by 2 man teams who adjust the position of the hose where necessary and remove sharp objects which might damage it. These teams are responsible for covering 1/4 mile of hose per hour. (Thus only a portion of the company is actually needed.) At the prescribed rate of 30 km per 20 hour day, it takes 6.4 days to lay the pipeline.

Tractor-trailer requirements for hauling and laying the hose are as follows:

TABLE 10-1

	<u>8" Hose</u>	<u>6" Hose</u>	<u>Total</u>
Average round trip, miles	85	187	-
Hauling time at 15 mph, hours	5.7	12.5	-
Loading time per trip, hours	1.0	1.0	-
Hose carried per trip, miles	2.84	3.79	-
Laying time at 5 mph, hours	0.6	0.8	-
Total time per trip, hours	7.3	14.3	-
Trailer loads required	30	9	39
Tractor-trailer days required	11	7	18

Tractor-trailer requirements for hauling pumping stations are as follows:

TABLE 10-2

	<u>8" Hose</u>	<u>6" Hose</u>	<u>Total</u>
Average round trip, miles	85	187	-
Hauling time at 15 mph, hours	5.7	12.5	-
Loading and Unloading time, hours	2.0	2.0	-
Total time per trip, hours	7.7	14.5	-
Trailer loads required	8	4	12
Tractor-trailer days required	4	3	7

The minimum required tractor-trailer days for hose and pump stations are 25. Given that the mission is about 6.4 days and using a 75% availability figure $\frac{25}{6.4 \times .75} = 5.2$ tractor-trailors are required. Rounding up, 6 tractor-trailors and 12 drivers are required. The costs for the sub-cycle are therefore as follows:

- Operation and Maintenance

At an operating and maintenance cost of \$10.43 per hour for tractor-trailors (See Chapter 6) the operating and maintenance

costs for laying the pipeline is

25 tractor-trailer days x 20 hours/day x \$10.43/hour = \$5.2K

- Manpower

Assuming that the cost of a full company is incurred for hose installation the cost is

122 men/company x 6.4 days/company x \$14,600/man year ÷ 365 days/year = \$31.2K

The 12 drivers cost 12 x 6.4 x \$16,033 ÷ 365 = \$3.4K and the total manpower cost is \$34.6K.

- Total Cost to Install System

O&M	\$ 5.2K
Manpower	<u>34.6K</u>
Total	\$39.8K

7. Operate System for 6 Months at 35,000 Barrels per 20 Hour Day

This computation is also consistent with the mission analysis description specified in Chapter 5 and exemplified in Chapter 6.

- O&M Costs

Based again on data in MERADCOM Report 2249 and the BHP ratings the operating and maintenance costs per hour are \$7.90 and \$4.42 for the large and small stations respectively. Based on requirements for 16 and 8 stations respectively, the cost is

Cost = 20 hours/day x 182.5 days [16 x \$7.90/hour + 8 x \$4.42/hour]
= \$590.4K

In addition to the regular O&M costs, based on MERADCOM Report 2249, one overhaul will be performed on the pumping station system. Based on overhaul costs from Report 2249 as well as the transportation involved, this cost is estimated to be \$653.6K (this consists of \$534.5K for the overhauls of the 24 stations plus \$119.1K for transportation) and thus total O&M costs are \$1244.0K

- Manpower Costs

This would be the same as the base case manual system or \$1781.2K.

● Total Operating Cost is \$3025.2K

8. Total Life Cycle Cost

Research and Development	\$ 665 K
Procurement	\$10,633.1K
Transportation-Manufacture to Depot	\$ 135.6K
Support Readiness	\$ 4,382.5K
Transportation to Theater	\$ 569.0K
Install System	\$ 39.8K
Operate System	\$ 3,025.2K
Thus, the total life cycle cost is	\$19,450.2K

CHAPTER 11

SECOND PHASE EVALUATION AND RECOMMENDATIONS

11.1 INTRODUCTION

This chapter presents the final evaluation of fuel transportation alternatives. The form of the chapter emphasizes the method of evaluation and reserves the presentation of the recommendations to the last section of the chapter. The actual policy to be followed by the Army in system implementation should depend somewhat on their own interpretation of the results presented here. For example, the recommendations depend on the sensitivity of the Army to cost and development risk. Therefore, the method of evaluation is presented before the final recommendation.

The method of evaluation is a compromise between treating the score for each attribute independently and converting the scores to a single score with a weighting formula fixed once for all. The non-cost attributes were grouped in three categories, and scores within each category were collapsed to a single numerical rating. These three ratings and two measures of cost comprise a set of ratings whose components are measures of:

- Life cycle cost with and without deployment
- An index of development risk
- An index reflecting system resource requirements for system installation
- A composite index of system performance and reliability

Because each of these attributes are in themselves important, and because it is difficult to perform a quantitative trade-off among these attributes, we chose to qualitatively evaluate each system on the merit of the values for the four attributes above. In this manner, for example, the performance or cost can be assessed without regard for other issues.

These attributes are not completely incommensurable. Life cycle cost can take into account some amount of development risk, system resource requirements and performance and reliability attributes. For instance, manpower levels can be costed and contingencies can be added to account for development risk. But such methods suffer from two weaknesses. First, these attributes can have an importance in their own right, and beyond that of their nearest dollar equivalent. If manpower requirements are high, the system is undesirable even if the dollar cost is not excessive. If development risk is too high, it may not be possible to develop the system at all. Second, the amount of dollars (or any other common unit) equivalent to a given increment of manpower or a given increment of reliability may vary from time to time and place to place, or even from evaluation to evaluation at the same time and place. For these reasons, we did not try to reduce the evaluation to fewer than the above components, of which only the cost values are unequivocally in the same units.

In the remaining sections of this chapter, the determination of each vector component and the summary conclusions are presented.

11.2 STEPS IN ANALYSIS

The reduction of the evaluation to the numerical summary vector was accomplished in three steps. The first step was a reduction of attributes to a reduced list. The second step was a reassessment from Phase I of all the attributes and the third step was a consolidation of the remaining attributes into the five valued vector.

The purpose in reducing the attribute list was to facilitate the final evaluation. The greatest reduction resulted from a consolidation of nine different cost attributes in the original attribute list into life cycle cost. Other reductions were accomplished as follows:

- Manpower for transport, special equipment for site transport, and ease of leak detection were eliminated because there were no important differences in these attributes among the final systems.
- The two reuseability attributes were aggregated into a single reuseability rating (and also categorized with system reliability and performance).
- Two attributes for transportability to theater were consolidated to one.
- The two attributes for manpower for assembly were consolidated to one.

The attributes dropped from the Phase I scoring and ranking included those attributes which were deemed: (1) not variable among the concepts; (2) of very minor significance; and/or (3) essentially represented by one or more attributes included in the list of attributes used for the final comparative evaluation.

Life cycle cost was computed two different ways, one with a single deployment of the system and a second calculation without any deployment. Cost without deployment includes all subcycles except transportation to theater, lay pipeline, and operate pipeline. Thus, the final list of attributes utilized for comparative evaluation was

Cost Attributes

- Life cycle costs with and without deployment

Development Risk Attributes

- Risk level
- Dependence on scarce resources

System Resource Requirements for Installation

- Transportability to theater (tons)
- Transport requirements to site (truck miles)
- Manpower for assembly (man hours)
- Dependence on special equipment

System Reliability and Performance Attributes

- Reliability of installation
- Degradation of installation under adverse conditions
- Operating reliability
- Maintainability
- Safety
- Lifetime
- Vulnerability
- Reuseability
- Manpower requirements for operation and maintenance.

In the second step of the analysis the system attributes were reevaluated in light of the mission analysis and state-of-the-art research performed in the second phase analysis. Some of the attributes, such as transportability to theater, transport requirements to site, and manpower for assembly, were computed on the basis of the mission analysis. Recall that these attributes were used in the computation of life cycle costs, but represented important measures in their own right. As an example, the baseline system requires a great deal of manpower and this affected the rating of this system through resource requirements as well as cost. The attribute evaluations are presented in Table 11-1.

Most of the system resource requirements attributes were quantifiable, specifically, tons transported, truck-miles for assembly and manpower for assembly. The qualitative requirements could then be converted into the 0-4 scale used in Phase 1.²¹ These are in parentheses in Table 11-1.

²¹ A score level of 5 was used to indicate that in some resource categories the tank truck system had no requirements whatsoever.

TABLE 11-1
 CONSOLIDATED ATTRIBUTE RATINGS
 FOR PIPELINE ALTERNATIVES

System	Costs		Development Risk		System Resource Requirements					System Reliability & Performance								
	Total Lifecycle Cost (10 ⁶ \$)	Cost Without Deployment (10 ⁶ \$)	Risk Level	Dependence on Scarce Resources	Transportability to Theater (Tons)	Transport Requirements to Site (truck miles)	Manpower for Assembly (Man hours)	P = Pipeline Co. D = Drivers	Dependence on Special Equipment	Reliability of Installation	Degradation of Installation Rate	Operating Reliability	Maintainability	Safety	Lifetime	Vulnerability	Reuseability	Manpower Requirements for Operation & Maintenance
Baseline	25.1	20.2	4.0	3.5	4684	16.7K	26400P +28000	3.5	3.0	3.0	3.0	3.3	2.8	2.8	4.0	3.0	2.5	4.0
Pipeline					(3.0)	(2.0)	(0.0)											
Mechanized	30.0	21.7	2.8	3.0	6116	15.9K	3800P +3300D	2.0	2.5	2.5	2.5	3.3	2.5	3.0	4.0	3.0	2.0	4.0
Pipeline					(2.0)	(2.0)	(3.0)											
Hose	19.4	15.8	1.5	2.5	1517	7.1K	1800P +900D	4.0	3.0	3.0	3.5	2.0	2.0	3.5	2.5	2.5	3.0	2.5
System					(4.0)	(4.0)	(4.0)											
Tanker	50.4	33.8	4.0	3.5	3309	-	-	4.0	4.0	4.0	3.5	3.5	2.8	3.0	3.0	4.0	4.0	0.0
Truck					(3.5)	(5)	(5)											

Scoring Key 5 = Outstanding
 4 = Excellent
 3 = Good
 2 = Fair
 1 = Poor
 0 = Highly Undesirable

Note: Relative Ratings are in Parenthesis when actual objective estimates were made.

For those attributes, such as reliability, for which there is no quantitative measure, the ratings were based on consensus opinion and were frequently the same as the Phase I evaluations. Ratings have been revised where necessary to reflect additional research knowledge. The rationale for final attribute scoring is as follows:

1. Major Attribute Category - Development Risk

- Development Risk

Development risk was assessed for each system. The tank truck option uses off-the-shelf equipment and would, therefore, score a 4.0. The baseline also requires no R&D and therefore received a score of 4.0. The mechanized pipeline system requires that two major components be designed; namely, the pipe joining machine and the automatic locking coupling. Both devices are well within the state-of-the-art, but some design risk is involved; we, therefore, rated the risk level at 2.8. The collapsible woven jacket hose, in our opinion, offers substantial development risk (the manufacturer, however, is confident of his ability to develop the hose on a time-frame about 10 months longer than the 48-month mission time-frame). The hose thus scored at 1.5 for development risk.

- Dependence upon Scarce Resources

The other development risk attribute is Dependence upon scarce resources. The tank truck concept and the baseline pipeline system both scored 3.5, because of the possible dependence upon welded steel pipe and couplings for the pipeline system and a vehicle manufacturer for the tank truck system. The mechanized pipeline scored at 3.0 because of its more specialized equipment requirements. The hose scored the lowest at 2.5 because medium pressure fuel hoses have not yet been developed.

2. Major Attribute Category - System Resource Requirements for Installation

- Transportability to Theater

Three out of the four attributes in this major category are quantifiable. An 0.0 to 4.0 (or 5.0) rating was assigned for them. The total tons of equipment and pipe transport required for the four systems is as follows:

- Baseline Pipeline System - 4,684 tons
- Mechanized Pipeline System - 6,116 tons
- Hose System - 1,517 tons
- Tank Truck System - 3,309 tons

The transport requirements include the conduit and installation equipment weight for dedicated equipment. Truck company equipment is assumed to be available at location. The values of the tonnages were scored on a basis of 0.0 to 4.0 as shown in Figure 11-1.

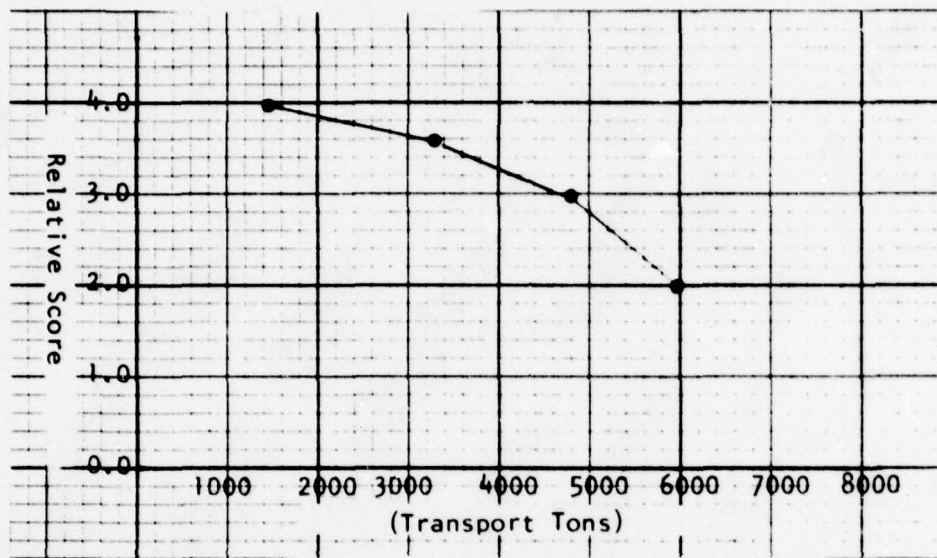

FIGURE 11-1

RATING SCORE FUNCTION FOR TRANSPORT TON REQUIREMENTS

- Transport Requirements to Site

The truck-miles required for pipeline installations are as follows for the four concepts:

- Baseline Pipeline System - 16,700 truck-miles
- Mechanized Pipeline System - 15,900 truck-miles
- Hose System - 7,100 truck-miles
- Tank Truck System - 0.0 truck-miles

The truck-miles estimated for each system have been converted to a 0.0 to 5.0 rating range as indicated in Figure 11-2.

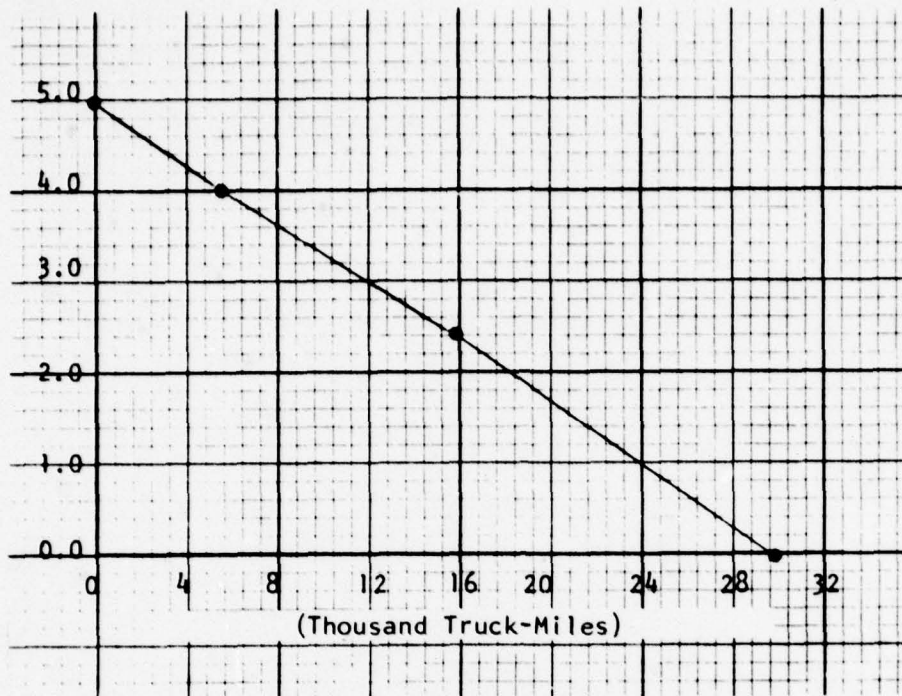

FIGURE 11-2

RATING SCORE FUNCTION FOR INSTALLATION TRUCK-MILE REQUIREMENTS

● Manpower for Assembly

The manpower requirements for pipeline assembly are measured in total man hours, based on the addition of both Pipeline and Terminal Operating Company and Truck Transport Company hours. The total assembly hours are as follows:

- Baseline Pipeline System - 29,200 man-hours
- Mechanized Pipeline System - 7,100 man-hours
- Hose System - 2,700 man-hours
- Tank Truck System - 0 man-hours

Figure 11-3 indicates how the manpower levels converted into the 0.0 to 5.0 ratings.

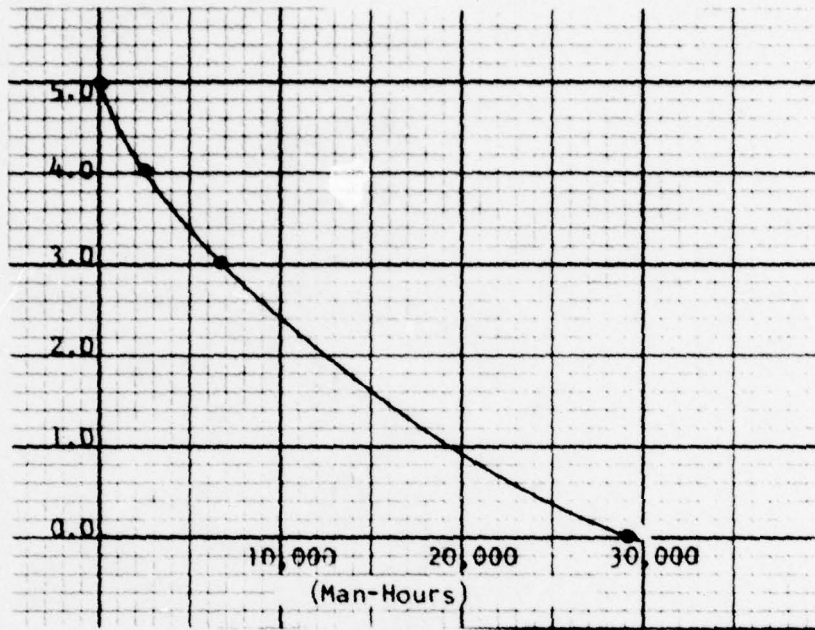

FIGURE 11-3

RATING SCORE FUNCTION FOR INSTALLATION MANPOWER REQUIREMENTS

● Dependence Upon Special Equipment

The dependence of the installation on special equipment was scored subjectively. The hose system is deemed the most flexible of the four systems in terms of installation under adverse conditions or conditions where equipment breakdowns occurred; it scored a 4.0; The tank trucks also scored a 4.0. The baseline pipeline system rated a 3.5. The mechanized pipeline system was rated the lowest because of its dependence on the use of specialized pipelaying equipment (three machines will be in use with one spare available). The mechanized pipeline system rates a 2.0.

3. Major Attribute Category - System Reliability and Performance

The attributes in this major attribute category were all rated subjectively for each attribute category. Each attribute was rated on the 0.0 to 4.0 scale.

- Reliability of Installation

The hose system was rated the most reliable in terms of installation- 4.0; as was the tank truck system. Correspondingly, lower in rating was the manual, baseline pipeline system at 3.0. Because the mechanized equipment depends upon relatively complex machinery it was rated at 2.5.

- Degradation of Installation Rate Under Adverse Conditions

The hose system and the tank truck systems were judged the best of the four. They were assumed to suffer some degradation of installation rate under adverse conditions and were thus rated at 3.5. The baseline pipeline system was rated lower at 3.0 and the mechanized pipeline system was judged most susceptible to adverse weather and terrain conditions and was thus rated at 2.5.

- Operating Reliability

The operating reliability depends upon a number of factors including the number of pump stations used, the nature of the conduit used and the number of couplings. The tank truck system scored well because of its built in redundancy; its score was 3.5. The two sectioned pipeline systems scored at 3.3. The hose system scored the lowest at 2.0 because of the increased number of pump stations and the greater possibility of hose rupture.

- Maintainability

All of the systems scored relatively low on maintainability because of the nature of the system. The baseline pipeline and tank truck systems scored the best at 2.8. The mechanized pipeline system scored slightly lower because of more effort required in replacing sections with the automatically locking coupling. The hose scored the lowest at 2.0 because of the greatest potential for problems due to wear and vandalism.

- Safety

Total systems safety differ slightly among the systems. The hose system would rate the best at 3.5, because of its ease in installation and the lower operating pressure involved. The baseline pipeline system rated lowest at 2.8, because of all the human labor involved during installation. The mechanized pipeline and the tank truck systems both have counter balancing risk factors (machinery in use versus truck movements) and were both assessed at 3.0.

- Lifetime

The tank truck system was rated at 3.0 because of the wear and tear effects placed upon the tank trucks within six months of operation. The two sectioned steel pipeline system scored a top value of 4.0 on lifetime. The hose system scored only 2.5 because it is believed that dynamic reactions of the hose to pressure variations causes wear and abrasion to the point that its useful life is not expected to be significantly longer than the six-month deployment period.

- Vulnerability

The tank truck system may be less vulnerable than the others and hence it scored a 4.0. The other systems are all vulnerable and the hose received a slightly lower score to reflect increased vulnerability.

- Reuseability

The most reuseable concept, of course, is tank trucks which rate a 4.0. The hose rates a 3.0 because it can easily be collected and reused (although its physical life and durability would become a factor in the field). The baseline pipeline system scored a 2.5. The mechanized pipeline system scored a lower value of 2.0 because of the problems of dealing with the locking coupling and its cleanliness requirements.

- Manpower Requirements for Operation and Maintenance

Both the pipeline concepts scored a top value of 4.0. The hose system was down-rated to 2.5 to account for the greater pumping station and maintenance costs. The tank truck concept was scored a value of 0.0 in this regard.

In computing the life cycle costs because of the uncertainties in hose and pipe prices, the basic costs were modified in two ways, and these are reflected in Table 11-2. Under both modifications hosing prices were raised about 18% as noted in Chapter 10 to reflect contingencies (to \$10.00 ft. and \$14.00/ft. for 6 and 8 inch hose respectively). Pipe prices were lowered in accordance with the pipe price variation discussed in Chapters 6 and 9. In the first modification, the decrease was 11.5% and 16.5% for 8" and 6" pipe respectively and in the second modification, the decrease was 23% and 33% respectively. The larger decrease is consistent with the 1976 price basis and a 39.4% price rise since then. (See section on Procurement Program and Subcycle, Chapter 6.) The first modification, which used an average of the original basis and the inflated 1976 price is utilized in a later tabulation. The sensitivity analysis in Table 11-2 shows that even with uncertainties the hose system has a cost advantage.

TABLE 11-2
 ALTERNATIVE PIPELINE SYSTEMS - LIFE CYCLE COST SUMMARY (Millions of Dollars)

	<u>Life Cycle Cost</u>		<u>Modified Costs</u>			
	<u>Total</u>	<u>Without Deployment</u>	<u>Hose Price Up and Steel Pipe Price Down*</u>		<u>Hose Price Up and Steel Pipe Price Down**</u>	
			<u>Total</u>	<u>Without Deployment</u>	<u>Total</u>	<u>Without Deployment</u>
Baseline	25.1	20.3	23.5	18.7	21.9	17.1
Mechanized	30.1	24.7	28.5	23.1	26.9	21.5
Hose	19.5	15.8	20.7	17.1	20.7	17.1
Tanker	50.4	33.8	50.4	33.8	50.4	33.8

* Steel pipe down in price 11.5% and 16.5% respectively for 8" and 6" pipe; and hose up approximately 18% to \$10.00/ft for 6" hose and \$14.00/ft for 8" hose.

** Steel pipe down in price 23% and 33% respectively for 8" and 6" pipe; and hose up approximately 18% to \$10.00/ft for 6" hose and \$14.00/ft for 8" hose.

In the final step of analysis, the attribute ratings in Table 11-1 were reduced to the numerical summary vectors. To perform this step, the various attributes for system reliability and performance were reduced to a single rating value. A similar reduction was performed for development risk and system resource requirements. The equation for the development risk index was:

- Development Risk Index = $.8 \times \text{risk level} + .2 \times \text{Dependence on Scarce Resources}$

This value is a weighted average of the two parameters.

The equation for the System Resource Requirements Index was:

- Resource Requirements Index = $.15 \times \text{Transportability to Theater}$
 $+ .15 \times \text{Transportability Requirements to site}$
 $+ .625 \times \text{Manpower for Assembly}$
 $+ .075 \times \text{Dependency on Special Equipment}$
 $- .5 \text{ If Assembly Manpower Rating Very Low}$

The equation was a weighted sum of the four attributes that emphasized assembly manpower. The .5 penalty was in recognition of the issue that any system with excessive manpower requirements during installation should be severely down-rated.

The only involved attribute reduction equation was for performance and reliability. Recognizing that there is a wide variation of performance and reliability attributes for any system, several methods for computing the overall rating were utilized. These are summarized in Table 11-3. The first three methods, modified Phase I, Average, and new weighting represent total scores of the form.

$$y_i = \sum_j a_j X_{ij}$$

where

y_i = Overall performance and reliability rating for alternative i

X_{ij} = Rating on performance and reliability attribute j for alternative i

TABLE 11-3

COMBINED RELIABILITY AND PERFORMANCE MEASURES USING VARIOUS WEIGHTING SYSTEMS
FOR THE ALTERNATIVE PIPELINE SYSTEMS

Alternative System	(1) Modified Phase I*	(2) Average	(3) New Weighting**	(4) Point Reduction	(5) Geometric Average +	(6) Assessed Overall Rating
Baseline	3.4	3.2	3.2	49	3.1	4
Mechanized	3.1	3.0	3.0	46	2.8	3.5
Hose	2.7	2.7	2.6	43	2.7	2.5
Tanker	3.1 (3.7)***	3.1 (3.5)***	2.8 (3.4)***	45 (50)***	0 (3.8)***	2.5(5)***

* Same as Phase I but ignoring some minor attributes

** Increased weight to operational reliability and maintainability and field manpower. Reduced weight to safety, lifetime and vulnerability

*** Ignoring the 0.0 score for the excessive manpower requirement for operation and maintenance

+ Reduced weight to safety, lifetime and vulnerability

and

$$\sum_j a_j = 1$$

where

the a_j are weighting constants.

For the modified Phase I scheme, the a_j are proportional to the weights in Phase I, except that some minor attributes are eliminated.

For the averaging scheme,

$$a_j = .125 \text{ for all } j$$

For the new weighting (adjusted so that the 0.0 - 4.0 is maintained)

$$a_j = .1875 \text{ for operating reliability, maintainability and manpower for operation and maintenance.}$$

$$a_j = .0675 \text{ for safety, lifetime, vulnerability}$$

$$a_j = .125 \text{ for others}$$

The new weighting reflects a modified emphasis on the relative importance of the attributes, which places greater emphasis upon reliability, maintainability and field manpower with reduced emphasis upon safety, lifetime and vulnerability.

The point reduction scheme gave each alternative 50 points and subtracts points for deficiencies as follows:

- Reliability of Installation: 1 point if less than 4
- Degradation of Installation Rate: 1 point if less than 3
- Reliability and Maintainability: 1 point for the mechanized system
4 points for hose
- Lifetime: 1 point for hose
- Reuseability: 1 point for the mechanized system
- Operation and Maintenance Manpower: 1 point for hose
5 points for trucks

For the geometric averaging scheme, the equation utilized was:

$$y_i = \prod_j x_{ij}^{b_j} \text{ or } \log y_i = \sum_j b_j \log x_{ij}$$

where Π represents products and

$$b_j = \begin{array}{l} .067 \text{ for safety, lifetime and vulnerability} \\ .133 \text{ for others} \end{array}$$

Upon examining the scores in Table 11-3, columns 1 to 5, the subjective assessed overall rating in column 6 was given to each system. The base-line received the highest rating, as it was a reasonable performer in all areas. The table also contains in parenthesis, values that the truck system would receive if the operation and maintenance manpower requirement problem did not exist. This issue is that the truck system is outstanding in performance and reliability except for this area. (There is one area where the latter system is deficient, and that is in the dependency on an acceptable highway network. Since the mission assumes an acceptable road network, we have not formally downgraded the system in this area.)

Table 11-4 summarizes the scores for the consolidated attributes. The life cycle cost figures were based on the steel prices as explained earlier in Section 11.2 and modified in Chapter 6. The recommendations based on Table 11-4 are discussed in the next two sections.

11.3 AN OVERALL UTILITY MEASUREMENT

Table 11-4 presents a listing of numerical evaluations that can be used directly by a decision maker. The table can be used in different ways. One way is a weighting scheme to determine overall utility as formulated by the equation:

$$Z_i = \sum_j C_j U_{ij}$$

where

Z_i = Overall utility for alternative

C_j = Weighting constant incorporating decision maker's utility for attribute category j .

U_{ij} = Rating for attribute category j and alternative i

By grouping the weightings used in the Phase I analysis (See Table 4-2), it is possible to get values of the C_j weighting for the four major attribute categories:

TABLE 11-4

LIFE CYCLE COST AND ATTRIBUTE TRADE-OFF TABLE - FOR FINAL ALTERNATIVES
(Costs Based on First Modification)

	Total Life Cycle Cost	Cost Without Deployment	Development Risk	Resource Requirements Index	Performance and Reliability Index
Baseline	23.5	18.7	3.9	.5	4
Mechanized	28.5	23.1	2.8	2.6	3.5
Hose	20.7	17.1	1.7	4	2.5
Tanker	50.4	33.8	3.9	4.7	2.5 (5)*

(Millions of Dollars)

Scoring Key: 5 = Outstanding
4 = Excellent
3 = Good
2 = Fair
1 = Poor
0 = Highly Undesirable

* Rating if Manpower Requirements for Operation and Maintenance were omitted.

- Life cycle cost, $C_1 = .32$
- Development Risk, $C_2 = .08$
- System Resource Requirements, $C_3 = .28$
- System Reliability and Performance, $C_4 = .32$

First, the life cycle costs have to be placed into a computible rating format. This is performed by using the rating transformation function as shown in Figure 11-4, where \$0.0 cost rates a 4.0 and \$50.4 million cost rates a 0.0.

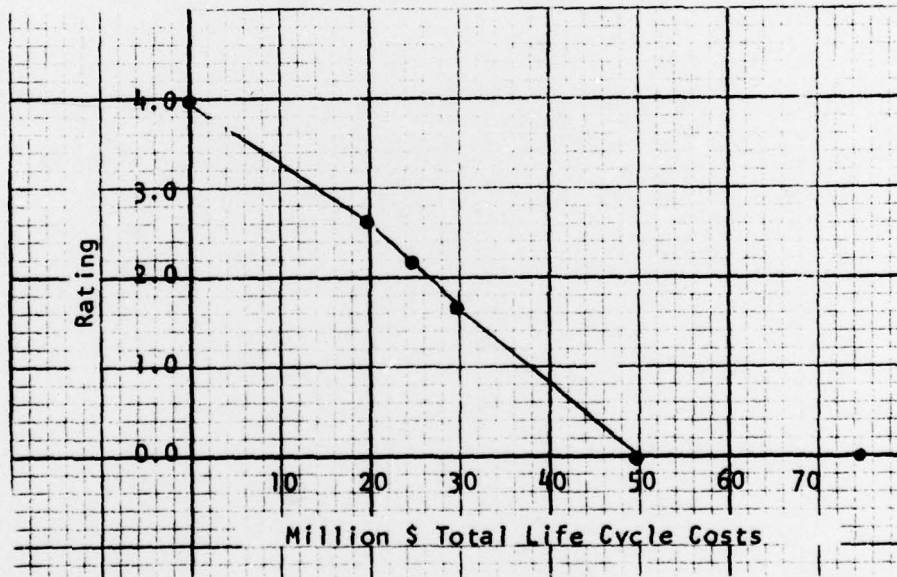

FIGURE 11-4

RATING SCORE FUNCTION PROPOSED FOR TOTAL LIFE CYCLE COST
(ILLUSTRATIVE)

Using the ratings of Figure 11-4 and the aggregated scores for each of the three other major attribute categories, the following scoring table resulted.

TABLE 11-5
PHASE 11: TOTALLY WEIGHTED AND SCORED ANALYSIS

	<u>Total Life Cycle Cost</u>	<u>Dev. Risk</u>	<u>Sys. Resource Requirements</u>	<u>Reliability & Performance</u>	<u>Net Weighted Score</u>
Baseline Pipeline	2.1	3.9	0.5	4.0	2.4
Mechanized Pipeline	1.8	2.8	2.6	3.5	2.6
Hose System	2.5	1.7	4.0	2.5	2.9
Tank Truck System	0.0	3.9	4.7	2.5	2.4
Weight	.32	.08	.28	.32	

According to the scoring shown in Table 11-5, the highest score would go to the hose system at 2.9 (out of 4.0). The next highest would be the mechanized pipeline at 2.6, and the baseline pipeline system, the tank truck system would be lowest at 2.4.

11.4 CONCLUSIONS AND RECOMMENDATIONS

The problem with the utility equation technique has been that it is frequently difficult to express a utility in equations, and the mathematics can obscure the actual trade-offs. A second method of evaluation would be subjective evaluation of Table 11-4. In this manner, Table 11-4 would represent a final output that the decision-maker should carefully evaluate. Upon a subjective evaluation, the following conclusions can be reached.

1. The trucking alternative, although generally excellent in other areas, is simply too costly. However, this alternative should be used as back up under certain conditions.
2. The baseline alternative uses too much manpower. This was known before this study was performed and the rating system corroborated this shortcoming in the area of systems resource requirements.
3. Given the unacceptability of trucks and the manual pipeline system, the choice is between hosing and mechanized pipeline. This choice involves a utility trade-off. The hose system is less expensive and easier to lay down. (That is, it is stronger in system resource requirements.) On the other hand, it involves more development risk and rates a little lower in performance and reliability.

Although performance and reliability are lower, there are some performance and reliability attributes, such as reliability of installation, degradation of installation rate, and reuseability, for which the hosing system is better.

Our own assessment was that under most decision-maker preferences, the hosing system should be the first choice. In particular, a decision-maker with low or moderate risk aversion would choose the hose system. Under these circumstances, performance and risk appear to be overcome by cost and system resource requirements advantages. In a practical sense, the characteristics of the hose system would make it particularly advantageous for the quick installation, short lifetime, systems that the Army is interested in. We wish to emphasize, however, that both systems merit consideration.

As has been emphasized in previous chapters, both systems would involve technical risk. An appropriate hose system still needs to be developed. For the mechanized pipelaying system, both a joint and machine must be developed. In view of the higher risk for the hosing system, the recommendation for the immediate future would be to direct research and toward the actual 300 psi hose. At a future date, the final suitability of this concept can be reevaluated.

APPENDIX 1
REFERENCES AND SOURCES

REFERENCES

1. Cost Reference Guide for Construction Equipment, 1979 Edition
2. R.L. Keeney and H. Raiffa, Decisions with Multiple Objectives, J. Wiley, 1976.
3. Letter from W. Studebaker on Pumping Station Costs
4. MERADCOM Cost Analysis Handbook, 2nd Edition, U.S. Army Mobility Equipment Research and Development Command, Fort Belvoir, Virginia, 1979.
5. Military Petroleum Pipeline Systems, Headquarters, Department of the Army; Washington, D.C.; TM5-343; February 1969.
6. Wayne E. Studebaker, Military Petroleum Pipeline Systems, Report 2249, U.S. Army Mobility Equipment Research and Development Command; Fort Belvoir, Virginia; June 1978.
7. Tables of Organization and Equipment
 - TOE 10-207H3 Petroleum Pipeline and Terminal Operating Company
 - TOE 55-18H6 Transportation Medium Truck Company

OTHER SOURCES

1. U.S. Army Mobility Equipment Research and Development Command
2. American Biltrite Corporation
3. Numerous Roll Forming Vendors. These included:
 - a. Oakley Products Corporation (314) 781-5552
 - b. Ardcor Division of American Roll Tooling, Inc (216)951-1200
 - c. Product Efficiency Co., Inc. (716) 891-5664
 - d. Gifford Hill Company (509) 535-1781
 - e. Yoder Company (216) 631-0520
4. Numerous Welding Vendors. These Included:
 - a. Thomson General Corporation (617) 272-2900
 - b. Shrewsbury Engineering Co. (617) 842-5164
 - c. Suburban Welding Company (617) 881-3200
 - d. Welder's Supply Company (617) 272-0400
 - e. Thermatool Company (203) 357-1555
 - f. Texas Instruments, Inc. (617) 222-2800
 - g. U.S. Thermit, Inc. (201) 657-5781

REPORT DOCUMENTATION PAGE		READ INSTRUCTIONS BEFORE COMPLETING FORM
1. REPORT NUMBER DAAK70-77-D-0024	2. GOVT ACCESSION NO.	3. RECIPIENT'S CATALOG NUMBER
4. TITLE (and Subtitle) SYSTEMS ANALYSIS OF METHODS FOR INSTALLING FUEL TRANSPORT SYSTEMS		5. TYPE OF REPORT & PERIOD COVERED Final Report January 1 1979 - June 30
		6. Performing Or. Report No. 80260-19
AUTHOR(s) Donald B. Rosenfield, Robert H. Bode, Herbert H. Loeffler, and W. Scott Nainis		8. CONTRACT OR GRANT NUMBER(s) DAAK70-77-D-0024
PERFORMING ORGANIZATION NAME AND ADDRESS Arthur D. Little, Inc. 20 Acorn Park Cambridge, Massachusetts 02140		10. PROGRAM ELEMENT, PROJECT, TASK AREA & WORK UNIT NUMBERS
11. CONTROLLING OFFICE NAME AND ADDRESS U.S. Army Mobility Equipment Research and Development Command - Procurement & Production Directorate, Fort Belvoir, Virginia		12. REPORT DATE June 30, 1979
		13. NUMBER OF PAGES 129
14. MONITORING AGENCY NAME & ADDRESS (if different from Controlling Office) Same #11		15. SECURITY CLASS. (of this report) Unclassified
		15a. DECLASSIFICATION/DOWNGRADING SCHEDULE N/A
16. DISTRIBUTION STATEMENT (of this Report) Distribution of this document is unlimited		
17. DISTRIBUTION STATEMENT (of the abstract entered in Block 20, if different from Report)		
18. SUPPLEMENTARY NOTES		
19. KEY WORDS (Continue on reverse side if necessary and identify by block number) Systems Analysis Cost-Benefit Pipelines Fuel Transport		
20. ABSTRACT (Continue on reverse side if necessary and identify by block number) A systems analysis was performed to evaluate different types of rapid pipe- line construction systems and other methods for installing fuel transport systems. The present manual construction methods do not meet the U.S. Army goals of laying 30 kilometers per 20 hour day. The systems analysis con- sisted of two phases of evaluating and scoring system attributes for numerous proposed systems. Five systems were considered for the second phase analysis, and two of these merit consideration for future development. These consist-		

SECURITY CLASSIFICATION OF THIS PAGE(When Data Entered)

of a mechanized pipelaying machine using sectioned pipes with a joint to be designed and a system of collapsible, medium pressure hose. The hose involves more development and does not score as highly in performance and reliability. However, the hose is less expensive and easier to install and therefore merits first consideration.

SECURITY CLASSIFICATION OF THIS PAGE(When Data Entered)



Arthur D. Little, Inc.

**CAMBRIDGE,
MASSACHUSETTS**

**SAN FRANCISCO
WASHINGTON**

ATHENS

BRUSSELS

LONDON

MADRID

PARIS

RIO DE JANEIRO

SÃO PAULO

TOKYO

TORONTO

WIESBADEN