

AD-A074 313 ARMY ARMAMENT RESEARCH AND DEVELOPMENT COMMAND ABERD--ETC F/6 17/2
A NEW CLASS OF OPTICAL COMMUNICATION SYSTEMS. I. EXPERIMENT.(U)
JUL 79 P H DEITZ, G L DURFEE, S S WOLFF

UNCLASSIFIED

ARBRL-MR-02930

SBIE-AD-E430 294

NL

| OF |
AD
A074313



END
DATE
FILMED
10-79
DDC

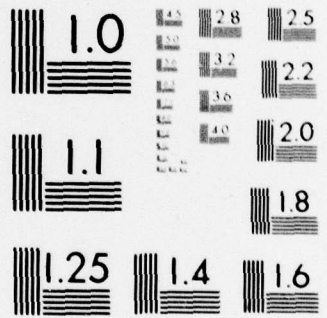

MICROCOPY RESOLUTION TEST CHART
 NATIONAL BUREAU OF STANDARDS-1963-A

12 LEVEL III

AD-E430294

AD A 074313

MEMORANDUM REPORT ARBRL-MR-02930

A NEW CLASS OF OPTICAL COMMUNICATIONS SYSTEMS: I. EXPERIMENT

Paul H. Deitz
Gary L. Durfee
Stephen S. Wolff

July 1979

DDC FILE COPY



US ARMY ARMAMENT RESEARCH AND DEVELOPMENT COMMAND
BALLISTIC RESEARCH LABORATORY
ABERDEEN PROVING GROUND, MARYLAND

Approved for public release; distribution unlimited.

DDC
RECEIVED
SEP 26 1979
B

79 09 14 026

Destroy this report when it is no longer needed.
Do not return it to the originator.

Secondary distribution of this report by originating
or sponsoring activity is prohibited.

Additional copies of this report may be obtained
from the National Technical Information Service,
U.S. Department of Commerce, Springfield, Virginia
22161.

The findings in this report are not to be construed as
an official Department of the Army position, unless
so designated by other authorized documents.

*The use of trade names or manufacturers' names in this report
does not constitute endorsement of any commercial product.*

UNCLASSIFIED

SECURITY CLASSIFICATION OF THIS PAGE (When Data Entered)

REPORT DOCUMENTATION PAGE		READ INSTRUCTIONS BEFORE COMPLETING FORM
1. REPORT NUMBER MEMORANDUM REPORT ARBRL-MR-62930	2. GOVT ACCESSION NO.	3. RECIPIENT'S CATALOG NUMBER
4. TITLE (and Subtitle) 6 A New Class of Optical Communication Systems. I. Experiment		5. TYPE OF REPORT & PERIOD COVERED
7. AUTHOR(s) 10 Paul H. Deitz, Gary L. Durfee, Stephen S. Wolff		6. PERFORMING ORG. REPORT NUMBER
9. PERFORMING ORGANIZATION NAME AND ADDRESS US Army Ballistic Research Laboratory ATTN: DRDAR-BLB Aberdeen Proving Ground, MD 21005		8. CONTRACT OR GRANT NUMBER(s)
11. CONTROLLING OFFICE NAME AND ADDRESS US Army Armament Research & Development Command Ballistic Research Laboratory ATTN: DRDAR-BL Aberdeen Proving Ground, MD 21005		10. PROGRAM ELEMENT, PROJECT, TASK AREA & WORK UNIT NUMBERS RDTGT NO 1L1611/2AH43
14. MONITORING AGENCY NAME & ADDRESS (if different from Controlling Office)		12. REPORT DATE 11 JUL 79
		13. NUMBER OF PAGES 26
		15. SECURITY CLASS. (of this report) UNCLASSIFIED
		15a. DECLASSIFICATION/DOWNGRADING SCHEDULE N/A
16. DISTRIBUTION STATEMENT (of this Report) Approved for public release; distribution unlimited.		
17. DISTRIBUTION STATEMENT (of the abstract entered in Block 20, if different from Report) 9 Memorandum reply		
18. SUPPLEMENTARY NOTES 18 SBIE / 19 AD-E430 294		
19. KEY WORDS (Continue on reverse side if necessary and identify by block number) Optical Communication Laser Speckle Spatial Multiplex Atmospheric Turbulence Spatial Diversity		
20. ABSTRACT (Continue on reverse side if necessary and identify by block number) (hmn/jdk) A new class of optical communication schemes is described in which a message is coded spatially in a random phase process and detected at many points at the receiver. This process may be termed a spatial-multiplex, spatial-diversity optical communication scheme. The technique shows relative immunity to the effects of atmospheric turbulence. Also, relative security of the method is assured since detection can take place only when radiation is detected and processed at many points within the beam itself.		

393 491

TABLE OF CONTENTS

	Page
LIST OF FIGURES	5
I. INTRODUCTION.	7
II. THE DEVICE.	9
III. SUPPLEMENTAL EXPERIMENTS.	14
IV. SUMMARY	20
ACKNOWLEDGMENT.	21
REFERENCES.	22
DISTRIBUTION LIST	23

ACCESSION for		
NTIS	White Section	<input checked="" type="checkbox"/>
DDC	Buff Section	<input type="checkbox"/>
UNANNOUNCED		<input type="checkbox"/>
JUSTIFICATION _____		
BY _____		
DISTRIBUTION/AVAILABILITY CODES		
Dist.	AVAIL. and/or	SPECIAL
A		

RECORDING PAGE BLANK

LIST OF FIGURES

Figure	Page
1. Laboratory setup for communication scheme	10
2. Dual channel cross-correlation device	10
3. Oscilloscope tracings of dual channel correlator.	12
4. Correlation function - spatial average.	14
5. Correlation function - temporal average	15
6. Correlation function - combined spatial-temporal average. .	15
7. Correlation functions for three cuts through speckle pattern	16
8. Correlation magnitude vs. angular alignment	17
9. Standard images (and associated power spectra) both with and without random phase modulation in propagation path .	18
10. Apparent spatial frequency shift due to random phase modulation.	19
11. Signal-to-noise measurements for binary communication link in the presence of random phase modulation in optical signal path	20

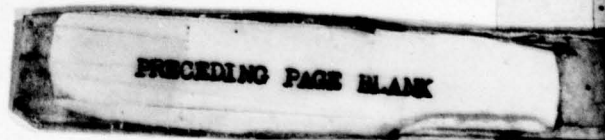

I. INTRODUCTION

Since the early 1960's, when gas lasers with visible illumination were first available, the most casual observer of radiation from these devices has been able to note with interest the granular pattern come to be known as a speckle pattern, which accompanies coherent radiation. In the past fifteen years, a large amount of surprisingly diverse work has been undertaken which nevertheless falls under the heading of speckle phenomena. The speckle effect has been used to describe spatial noise in acoustic, microwave, and optical holographic reconstruction, the diffraction pattern resulting from coherent optical scatter from a diffuse surface, the granular noise present in atmospherically degraded telescope images and even the corresponding irradiance distribution within the receiver pupil. The thread common to each of these studies is that when radiation of sufficient coherence is scattered from or transmitted through a surface or volume characterized by random phase, a diffraction pattern of a stochastic nature is generated. It is not necessary for the source of radiation itself to be highly coherent; by means of propagation (à la the van Cittert-Zernike theorem) the coherence of the radiation may attain levels sufficient for the formation of speckle patterns in, for example, stellar imagery. Indeed, the history of speckle patterns is now a century old.

In general, the nature of a received speckle pattern may be due to the characteristics of the radiation source, a surface from which the energy may have been scattered, or the characteristic of the medium through which the radiation has propagated. In this paper we wish to utilize in a device some characteristics of the second type, the nature of the received speckle statistics as they relate to the surface through which coherent light has been scattered. There are still two areas of concern within this subset: the phase characterization of the scattering surface and the amplitude distribution over the surface. It is this latter aspect of the problem that we are addressing here.

In a previous paper¹, the subject of image information by means of speckle pattern processing was discussed with a view to the unifying aspects of a series of different detection and processing schemes. As noted, one speckle processing method having roots in the Hanbury Brown Twiss experiment, is called irradiance correlation. To review this technique, we refer to Figure 1. Coherent light illuminates a surface having a random phase distribution. In the far field the resulting irradiance distribution is detected. We take two points in the detection plane, form the irradiance product and seek the expectation value (ensemble average) of this product. The domains available to us by which we can infer this average are, of course, the time and space

1. P.H. Deitz, "Image Information by Means of Speckle-Pattern Processing", *Journal of the Optical Society* 65, pp. 279-285 (1975).

domains. That is to say, if the received irradiance (speckle) pattern does not change in time, we may translate about the pattern forming products of irradiance pairwise, all for the same relative separation and orientation, and compute the average. This is a spatial average. Or, if the source phase characteristics vary in time, we may remain at the same two points in the detection plane while the pattern changes in time and forms an average. This is an average in the time domain. Or it is possible to form a combination of averages.

As discussed previously,¹ the second moment in irradiance for the experiment described can be expressed as

$$\begin{aligned} \langle I(\underline{x}_1) I(\underline{x}_2) \rangle_{(\)} &\propto | \langle \hat{v}(\underline{x}_1) \hat{v}^*(\underline{x}_2) \rangle_{(\)} |^2 \\ &\propto \left| \int_{-\infty}^{\infty} \int_{-\infty}^{\infty} I(\underline{\xi}) \exp \left[-i \frac{h}{R_0} (\underline{x}_1 - \underline{x}_2) \cdot \underline{\xi} \right] d\underline{\xi} \right|^2, \end{aligned} \quad (1)$$

where \hat{v} represents the spatial fourier transform of the source electric field, \underline{x} and $\underline{\xi}$ represent positions in the receiver and source planes, respectively, k is the wavenumber of the light, and R_0 is the distance between the source and receiver planes. The parentheses, $(\)$, imply a domain, not yet specified, in which the averaging takes place. Equation (1) relates the second moment in irradiance to the spatial power spectrum of the source radiance distribution. Since the power spectrum of a function does not uniquely define the function, even a noise-free measure cannot be used to infer the radiance distribution of an arbitrary object. The problem is further complicated because of the relatively poor signal-to-noise characteristic of an incoherent detection technique. Thus irradiance correlation as a general means of source radiance estimation is not particularly useful.

However, in the context of a detection scheme, this means of information processing may have more utility. Rather than inferring the radiance distribution for an arbitrary source, a set of orthogonal source functions is chosen where the orthogonality is defined in the spatial power spectrum of object radiance. Then the signal processing problem at the receiver reduces to one of detection rather than estimation. A communication process is therefore defined, that might be termed a spatial multiplex, spatial diversity scheme. The spatial multiplex aspect arises because of the necessary presence of a random phase screen (ground glass) at the source to guarantee the spatial incoherence of the radiation emanating from the object. The presence of this element destroys the normal diffraction pattern of the object in much the same way that a spread spectrum modulation technique disguises the temporal character of transmitted information. The spatial diversity arises, of course, from the multiplicity of detection points used in the receiving process.

In most communication systems, the message coding is handled by temporally modulating the total intensity of the transmitted beam. There are two principle disadvantages to this process: (1) the turbulent atmosphere in the propagation path also modulates the beam in space and time, causing errors in the detection process and (2) the presence of aerosols along the optical path causes some of the optical energy to be scattered out of the beam. This off-axis scatter can be observed at large angles to the initial direction of beam propagation and by monitoring the irradiance fluctuations, the message being transmitted can be inferred.

In the technique being discussed here, the information being transmitted is coded in the cross sectional (spatial) character of the optical beam, not the total energy being transmitted. To infer the message, the beam must be detected at many points within its extent and the detected signals then properly processed. Radiation scattered from the beam does not retain the spatial character necessary for decoding since it is only related to the total energy being transmitted. In addition, because the detection does not take place in the fourier transform plane of the receiver optics, the method is relatively insensitive to the degrading effects of atmospheric turbulence by comparison with standard image-forming methods.

II. THE DEVICE

For a description of the operation of this communications device², we refer to Figure 1. This schematic shows a simplified diagram of the equipment layout used to test the basic physical relationships. The light source is a laser. A coherent source of light is critical to this method since this approach is based on the generation of laser speckle patterns in the optical farfield. Light from the laser falls directly on the plane labeled "spatially encoded message." This message bit is composed of a section of ground glass in close proximity to an aperture function, typically an isometric bar grating of some spatial frequency and orientation. Provision is made for inserting another isometric bar grating of a second spatial frequency (same orientation). The ground glass is arranged so that it can be spun by means of a motor. In the diagram, a lens is used to achieve the far field optics condition normally acquired through propagation over a long free-space path. The use of the lens affords a geometrical compactness for this bench setup. Following the lens, a rotating mirror intercepts the beam, deflecting it to a bank of three photomultipliers. The motion of this mirror causes the laser beam to be swept across the three photomultipliers, giving effectively a one-dimensional spatial scan through the laser beam. This scan is made perpendicular to the orientation of the bars of the isometric

2. US Patent No. 4,085,319; awarded April 18, 1978.

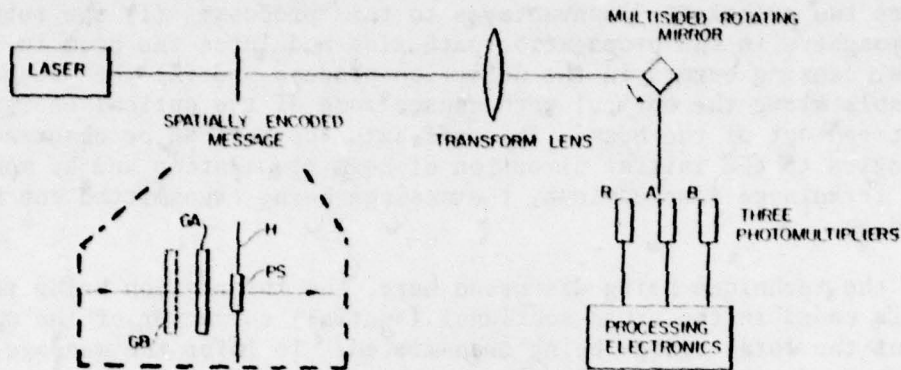

Figure 1. Laboratory setup to demonstrate communication scheme. Optical source is a laser whose output is directed to a spatially encoded message (generally an amplitude grating) in close proximity to a random phase screen (ground glass). Transform lens gives the fraunhofer pattern of the spatial message at a foreshortened range. Multisided rotating mirror reflects beam to bank of three photomultipliers. Insert gives details of spatially encoded message. Random phase screen PS (ground glass) is present in aperture H. Amplitude grating GA (or GB) forms spatial message bit for transmission to detection plane.

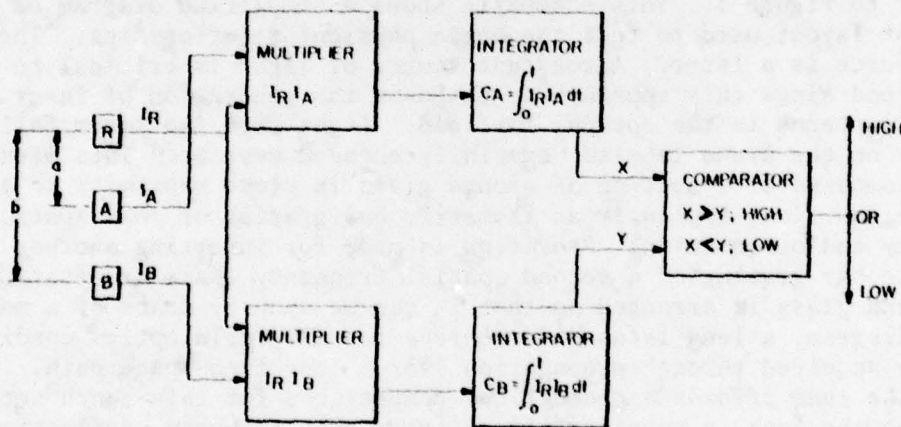

Figure 2. Dual channel cross-correlation device. Output of photomultiplier tube, R, is cross-correlated simultaneously with the outputs of tubes A and B. Functions are estimated by multiplying and integrating in each channel for a time t . At the end of the cycle, a comparator indicates the channel with the higher integrated power.

bar grating. The PM tube apertures are about 1/5 the diameter of the average speckle size present in the far field to prevent aperture averaging.

For a particular isometric bar grating, specific spatial frequency information is present in the far-field speckle pattern. This information in the far-field speckle pattern is mathematically related to the fourier transform of the intensity at the isometric bar grating. When the speckle pattern is detected by the PM tubes (a squaring process) and

electronically cross-correlated ($C = \int_0^t I_R I_A dt$, where I_R = output of

PM tube R, I_A = output of PM tube A and t = some predetermined time interval), the resulting correlation function, C , is related to the power spectrum of the intensity on the original isometric bar grating (see Fig. 2). This correlation function can be maximized for a specific bar grating by separating a pair of PM tubes by a distance corresponding to the far field spatial lag for the fundamental spatial frequency of the bar grating. If PM tubes R and A are separated properly for bar grating "a", and PM tubes R and B are separated properly for a second bar grating "b", then a binary communication system has been established; while the speckle pattern is interrogated for spatial frequency components, only one or the other is present in this particular setup. Thus, if bar grating "a" is present in the beam, then the cross correlation function produced from PM's R and A (C_A) will be a maximum, while the cross correlation function produced from PM's R and B (C_B) will be a minimum (noise level). Replacing bar grating "a" with "b" reverses the results; C_B becomes greater than C_A . Speckle information is made available to the PM tubes for detection and processing by three means: spatial scan, temporal scan, and a combination of spatial/temporal scans.

In the spatial scan mentioned above, the ground glass at the laser transmitter is fixed, and the rotating mirror causes the nonchanging laser speckle pattern to move across the PM tubes thus giving, in this instance, a one-dimensional spatial scan across the speckle pattern.

In the temporal case, the ground glass (located close to the bar grating) is rotated, causing the speckle pattern itself to change with time while the rotation mirror is held fixed. Thus, the three PM tubes detect at only three specific places in the laser beam, but are provided with a changing speckle pattern produced by the rotating ground glass. (Note, however, that the speckle pattern at 0 radians is reproduced periodically at 2π radian rotations.)

In the temporal/spatial combination the ground glass and the mirror are both rotated, providing greatly increased statistical sampling. The combined method has the advantage of making the maximum number of speckle

statistics available for detection and processing and, hence, increasing the system signal-to-noise ratio. In addition, by scanning through the beam, spatial noise due, for example, to atmospheric turbulence (which remains essentially unchanged during the transmission of a message bit) tends to average out spatially.

Thus, in this simple laboratory demonstration, one of two bar gratings is placed in close proximity to a section of ground glass at the transmitter and illuminated by coherent light. If three photomultiplier tubes are used in conjunction with a rotating mirror configuration at the receiver, the net effect is to detect a speckle pattern at many different points. The processing electronics are comprised of a dual-channel correlator which simultaneously computes a time-averaged correlation of the photomultiplier outputs of R with A and R with B. If the mirror is rotated, this time record also corresponds to a space average over the receiver plane. At the end of the computation time, the correlation values are compared. Since the interdetector spacings, a and b , are so chosen to infer the fundamental spatial harmonics of bar gratings "a" and "b", a significant difference in power at the output of the dual integrators implies the presence of a particular grating.

Figure 3 shows a sample of oscilloscope traces giving the results of the dual integrations. In Figure 3a, ruling "a" is in place showing a repetitive accumulation of power in integrator a. It can be noted that integrator b is fluctuating about some background noise level. In Figure 3b, ruling "b" has been inserted at the transmitter. Here, trace "a" reverts to background level and channel b exhibits large deflections at the completion of the timing cycle. Subsequent circuitry compares the deflection in the two channels and signals the larger of the two.

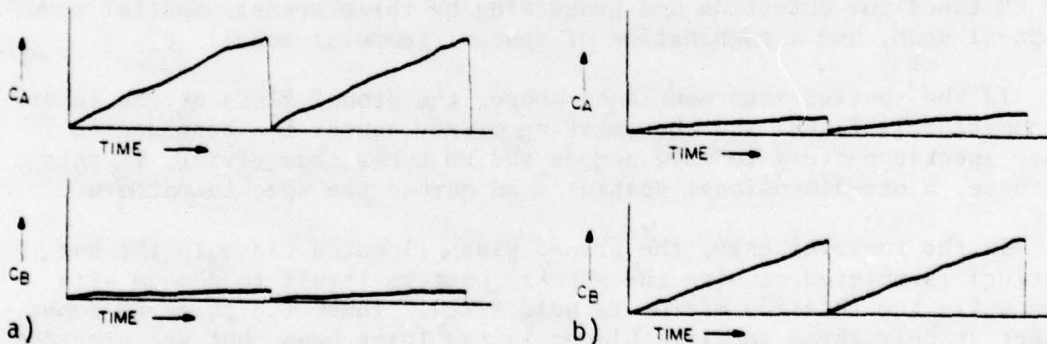

Figure 3. Oscilloscope tracings of dual channel correlator. a) Grating a is in transmitter aperture resulting in large integrated power in channel a. b) Grating b is in transmitter aperture so that greater power is measured in channel b.

From the above description, it should be obvious that the device description shows only a few of many ways in which the basic principle of this technique can be exploited. There are two central ideas in this communication process. First, the process is a spatial multiplex one since the spatial frequency bit (isometric bar grating, etc.) is put in close proximity to a rough random phase screen (ground glass) and then illuminated by coherent light. The effect of the random phase modulation is to destroy what might otherwise be a recognizable far-field diffraction pattern of the object field distribution. Hence, the information at the transmitter is being spatially modulated by the random phase screen. Second, the process involves spatial diversity detection. For the method to work, the far-field irradiance distribution must be detected at points pairwise in order to compute a correlation function. But in addition, the process is statistical and involves making averages. If the transmitter is arranged to send a time invariant signal (the ground glass is held static), the only means for obtaining an average is by a traversal across the receiver plane. This could be effected by using a multipoint sensor such as a chargecoupled device. As mentioned earlier, statistical fluctuations can be smoothed by averaging in time from readings at fewer points if the source can be made to exhibit a time history of its own. This can be accomplished by rotation of the ground glass. If possible, it is desirable (for reasons which follow) to eliminate the ground glass rotation from communication systems in certain applications.

There are a number of important implications of this process which we will list:

1. Although the above experiment was accomplished by modulating the whole transmitting aperture with just one isometric bar grating, hence transmitting only one bit, it is obvious that multiple bits can be sent by a number of schemes either by segmenting the aperture and assigning individual portions to specific spatial frequencies at particular orientations or by overlaying various spatial signals at different angular orientations.

2. Because the detection is made in the receiver plane without any image-forming lenses, random phase modulation induced by an interlying medium (turbulent atmosphere) has far less effect in degrading the inferred image information.

3. Because the process depends upon detection of speckle statistics at many different points within the beam in order to make a useful estimate, the total energy being transmitted has no bearing on the message bit (or bits) being sent. Hence, aerosol scattering along the path (which removes energy at wide angles to the axis of the system), does not provide an off-axis observer with information useful in inferring the information being sent even if the observer were to know the method of coding completely.

III. SUPPLEMENTAL EXPERIMENTS

A. Various Averages.

In order to clarify these points and to demonstrate some of the basic operating conditions of this kind of signal processing, we describe a series of tests undertaken prior to the construction of the communication device itself. In an early test, the configuration illustrated in Figure 1 was utilized with the following changes. As usual, an isometric bar grating was placed at the transmitter in close proximity to the ground glass and held static. However, in the detection plane only one photomultiplier was used. The output of this device was sent to a signal processor to be autocorrelated. The multisided mirror served to scan a line through the time-invariant far-field speckle pattern. The output of the autocorrelator, shown in Figure 4, gives the autocorrelation function for this one scan as a function of τ , the effective spatial lag in the detector plane. Since this function is an estimate of the spatial radiance power spectrum of the object (bar grating), the value at τ equal to zero relates to the average power of the bar grating (of no particular importance to us here). However, the harmonic shown

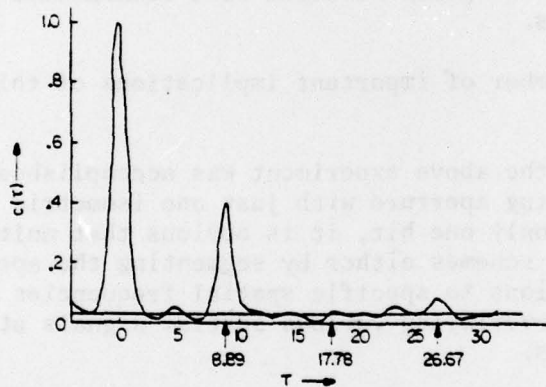

Figure 4. Correlation of one-dimensional speckle scan vs. spatial lag. Fixed ground glass (time invariant pattern). Averaging strictly spatial.

at a lag of 8.89 mm gives a measure of the power present in the detection plane due to the 52 l/cm fundamental harmonic at the transmitter. If the bar grating were replaced with one of another spacing, this harmonic would have appeared at another lag, indicating power at some other frequency. Thus, autocorrelation measurements in the detection plane, which depend on spatial lags of a particular magnitude and orientation, result in an estimate of the spatial harmonic composition of a given object radiance distribution.

The goodness of the estimate is related directly to the number of independent statistical measures extracted at the detection plane. If instead of making one linear scan through the speckle pattern, two detectors are set at a given spacing and the statistical variations are introduced by spinning the ground glass at the transmitter as described earlier, a more complete statistical description is found for this experimental configuration, as can be seen by the results shown in Figure 5. Here, two photomultipliers are used in the detector plane while the ground glass is spun, and the cross-correlation function is examined as a function of detector separation. A more reliable estimate of the object spatial spectrum is derived at values of the higher harmonics (marked at spatial lags of 17.78 and 26.67 mm). However, if both methods of statistical evolution (time change through ground glass movement and linear spatial scanning by mirror rotation) are utilized, an even larger statistical sample is brought to the electronic processor, resulting in the combined temporal-spatial average shown in Figure 6.

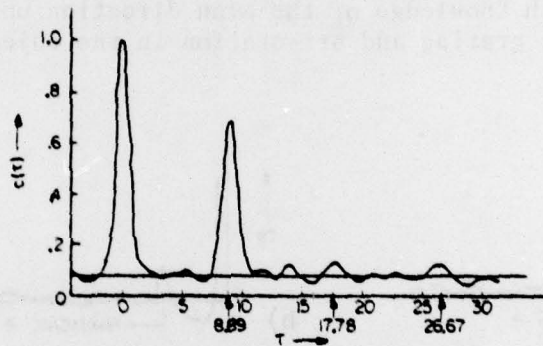

Figure 5. Cross correlation of speckle pattern from two points vs. spatial lag (separation). Ground glass in transmitter aperture is moving, giving a time-variant speckle pattern. Averaging is strictly temporal.

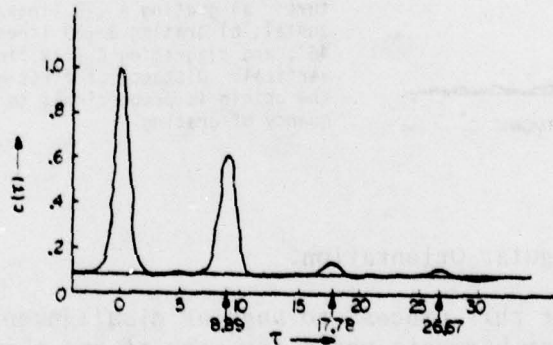

Figure 6. Cross correlation of speckle pattern using moving ground glass in the transmitter aperture and rotating (multisided) mirror to scan spatially as well. Averaging is a combined temporal-spatial process.

The operation of the communication device discussed earlier can be more easily understood now. Since two bar gratings of different frequency can be uniquely identified by their fundamental spatial periods, comparison of power measurements in the detector plane at the two appropriate lags can be used to infer the presence of a particular grating.

B. Simultaneous Bit Encoding.

Since the direction as well as the magnitude of the correlation lag is important, it is obvious that a number of objects can be used simultaneously rather than just one at a time. To demonstrate simultaneous bit transmission, three different bar gratings were overlaid on each other, two at 90-degree orientation, the third at 45 degrees. The same speckle pattern at the detection plane was then scanned and processed at the three appropriate orientations by the spatial average method demonstrated earlier in Figure 4. The results of this trial are shown in Figure 7. In each autocorrelation function, the position of the first harmonic, together with knowledge of the scan direction, uniquely defines the corresponding bar grating and orientation in the object plane.

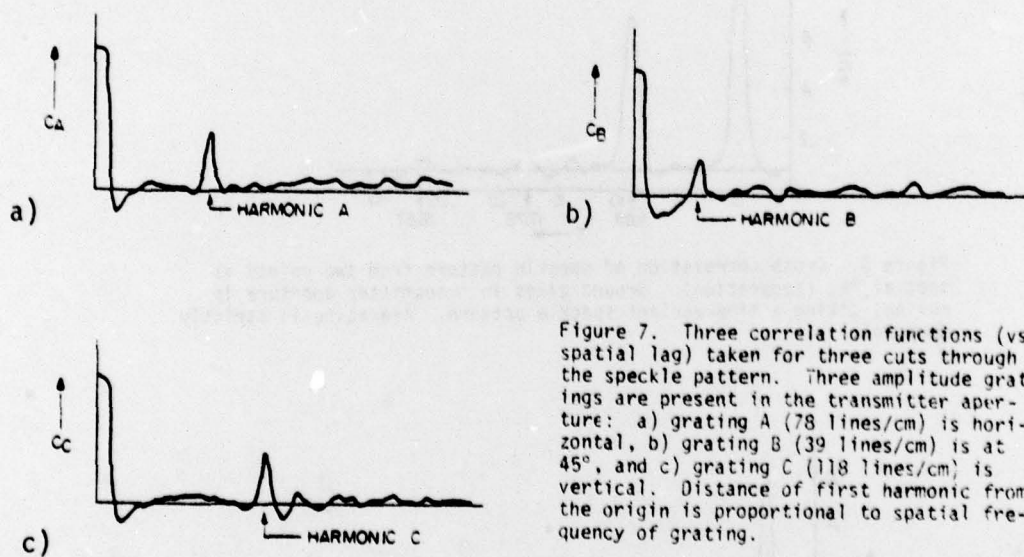

Figure 7. Three correlation functions (vs. spatial lag) taken for three cuts through the speckle pattern. Three amplitude gratings are present in the transmitter aperture: a) grating A (78 lines/cm) is horizontal, b) grating B (39 lines/cm) is at 45°, and c) grating C (118 lines/cm) is vertical. Distance of first harmonic from the origin is proportional to spatial frequency of grating.

C. Sensitivity to Angular Orientation.

The sensitivity of this process to angular misalignment will now be demonstrated. The first harmonic peaks for each of the three scans shown in Figure 7 represent concentrations of energy a distance from the origin of the power spectrum proportional to the spatial frequency of a particular grating. That is to say, harmonic B is found closest to the

origin (has lowest spatial frequency), harmonic A is next in distance from the origin, and harmonic C is farthest from the origin (has the highest spatial frequency). Since the spatial extent (i.e., uncertainty in frequency space) of the three first harmonics is essentially the same, the sensitivity of the apparent power in these harmonics should be proportional to the distance of the harmonic from the origin. This should be true since the absolute traversal in frequency space for a given angular rotation gets larger as the frequency (distance from the origin) gets greater.

The effect is shown in Figure 8, in which the power measured at the first harmonic spatial frequency is plotted against angular scan misalignment (zero degrees corresponds to optimum alignment) in degrees. The three curves in decreasing width give the results for the three spatial gratings in ascending frequency. Hence the sensitivity of the spatial scan alignment in the detection plane with respect to the frequency grating in the transmission plane is proportional to the spatial frequency being utilized.

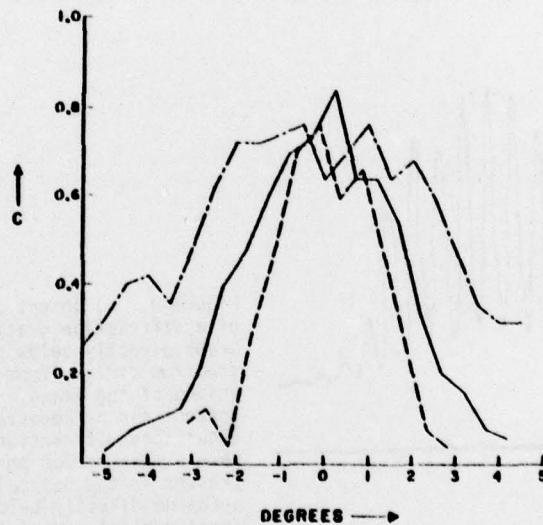

Figure 8. Correlation magnitude of first harmonic vs. angular misalignment in detection plane for three amplitude gratings. In each case the grating is oriented vertically in the transmitter aperture. Zero degrees orientation indicates a scan in the detection plane horizontally. Since the spatial extent of the first harmonic is essentially the same for all the gratings, the sensitivity to angular alignment of the detection plane is proportional to the distance of the harmonic from the origin. Hence detections with the highest frequency gratings are most sensitive to angular alignment. ···· shows data from 39 lines/cm grating, — from 78 lines/cm grating, and - - - from 118 lines/cm grating.

D. Insensitivity to Random Phase Modulation

To illustrate another of our assertions, that this method of spatial information transmission is relatively insensitive to random phase modulation along the transmission path, we performed the following test for comparison purposes. Referring to Figure 1, a bar grating was placed in the object plane and the ground glass held static. Immediately before the detection plane, an image-forming lens was placed so that an extremely small portion of the grating image illuminated a pin-hole aperture of a photomultiplier. When the four-sided mirror was rotated, the image could be scanned. This function is shown in Figure 9a, above the graphed function. Next the power spectrum of this image scan was computed and is shown directly below. It should be noted that this is the identical harmonic content that is inferred by the method of speckle pattern processing. The presence of the first harmonic is clearly seen in this function. Next, a section of glass exhibiting weak random phase distortion was inserted in the optical transmission link. The effect of this glass was to distort the image. This degraded image was then scanned and the corresponding spatial power spectrum computed. These results are shown in Figure 9b. The image is seriously degraded, so much so that the power spectrum no longer defines the harmonic content of the object spectrum.

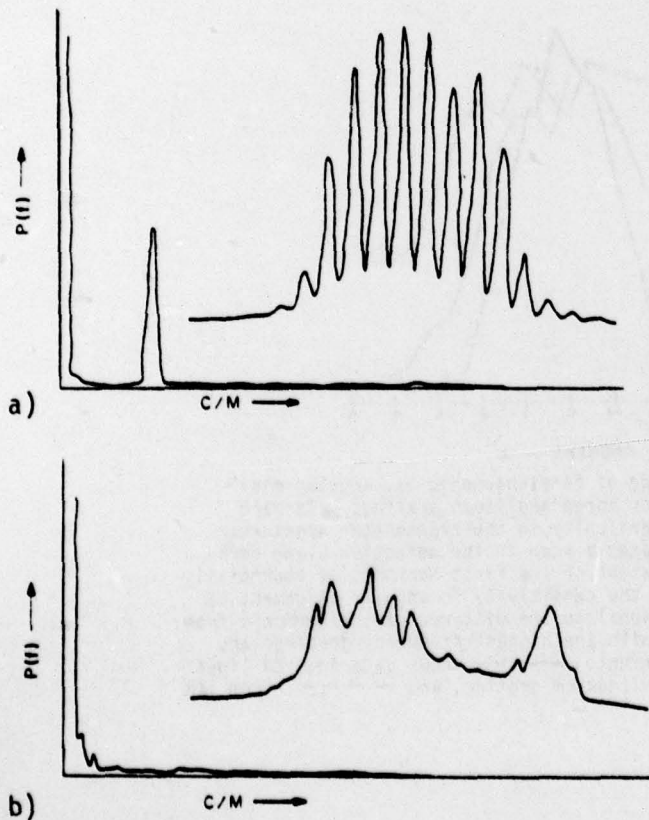

Figure 9. a) Insert shows the image of a diffraction grating using a lens. Graph directly below shows the power spectrum derived from standard processing of the image. Strong harmonic content can be observed. b) Insert shows same diffraction grating image when a weak random phase screen is present in the optical path. Power spectrum directly below shows harmonic content can no longer be identified. This experiment shows the considerable sensitivity that a standard image-forming system has to random phase modulation along the propagation path.

To test the sensitivity of the speckle method to this kind of distortion, the spatial average method (illustrated in Figure 4) was utilized in the following way. As shown in Figure 4, without the distorting phase screen, the detector lag is 8.89 mm to measure the power associated with the first harmonic. The strength of this unperturbed harmonic was plotted in Figure 10 at the abscissa position 0, and is labeled as such. Then, the random phase screen was inserted in the transmission path. The magnitude of the correlation function in general decreased. The amount of the lag (effective detector separation) was then adjusted so as to maximize the magnitude of the correlation reading. An increase in the separation resulted in a new magnitude plotted for positive τ , a decrease in negative τ . Some forty readings were taken for each of forty particular positions of the phase screen. It can be seen that the effect of the random phase screen on any one reading was to increase or decrease the apparent frequency of the harmonic content of the ruling. However, when the separate readings were averaged, the mean measurement converged very closely to the true, undistorted value. Thus, by this speckle method, not only was the harmonic information not lost in a noisy transmission, its apparent (average) value was shifted only slightly in frequency.

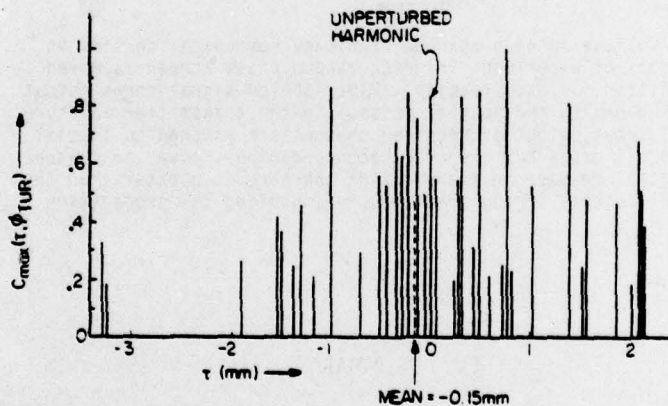

Figure 10. Relative magnitude (indicated by height) and shift for some forty spatial frequency readings in which a random phase screen was moved to a new position for each reading. Position of spatial harmonic in the absence of random phase modulation is also shown. Average (vertical dashed line) of all readings converges to unperturbed value.

E. Further Random Phase Statistics

Figure 11 shows further data describing the effects of turbulence on the operation of a binary communication link as described initially. Here an isometric bar grating has been placed in the transmitter aperture. In the detection plane, harmonic information was estimated at two spatial lags appropriate for bar gratings of 52 and 78 lines/cm. Both power readings were made for 80 individual positions of the random phase screen. As can be seen in Figure 11, in all cases but one, greater power is measured in the channel carrying the spatial content of the 52 lines/cm grating (labeled signal in Figure 11) than in the channel measuring signal content at 78 lines/cm and, hence, simply labeled background noise.

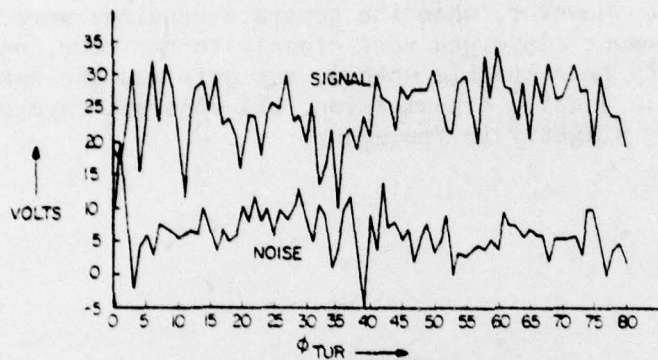

Figure 11. Voltage in each channel of binary communication link vs. 80 realizations of experiment in which random phase screen is moved to a new position for each reading. Plot labeled signal shows output from channel tuned to the spatial message in the transmitter aperture. Noise signal shows output of receiver channel not matched to spatial message. In all cases but one (the second reading), power in channel tuned to spatial message in transmitting aperture is greater than the noise channel despite strong phase modulation along the propagation path.

IV. SUMMARY

In this paper, we have attempted to describe a particular method of signal modulation, transmission, and decoding that we have chosen to call spatial-multiplex, spatial-diversity optical communication. There are, of course, many other techniques that may be used to transmit optical data of a spatial nature, including direct projection of transparencies by optical systems or by using image-forming optics at a reception plane. In this method, no image-forming lens is used. Coherent light is used to illuminate a transparency upon which a bit (or bits) is coded according to amplitude modulation within a transmitting aperture;

the bit is characterized by some spatial frequency and orientation. In close proximity to the message bit (or bits) the optical beam must be randomized by transmission through a phase screen of fast phase variation (such as ground glass). At the path terminus of the communication link, the resulting optical speckle pattern must be detected at many points, with this data being properly cross-multiplied and averaged; that is to say a two-dimensional correlation function of the received intensity must be computed and examined at spatial lags appropriate for the chosen transmission format. The rate at which information may be transmitted depends upon many complicated tradeoffs including the number of bits being coded simultaneously, the size, number and speed of the detectors, and the spatial noise along the link itself.

Of fundamental importance to this technique is the fact that a particular message bit(s) being transmitted is inferred by second-order correlations of intensity transverse to the optical axis and is, thus, independent of total transmitted power. Light scattered out of the primary beam by aerosols does not contain any information useful to off-axis observers who are constrained to view only volume scatter out of the beam. Thus, although the method may reveal the presence of a communication link to an outside observer, the method offers a high degree of security since access to the necessary statistical measures can be gained only by physical penetration of the primary beam itself.

In addition, because the reception scheme utilizes only direct energy (intensity) detection, the method is relatively insensitive to random phase modulation along the link from, for example, the effects of turbulence. Since the beam is detected immediately, without passage through any phase adjusting devices (such as lenses), pure phase distortion is lost immediately in the square-law detection process. Depending on complicated system parameters which relate to the overall signal-to-noise ratio, more than one bit can be coded and transmitted simultaneously by either segmenting the transmitting aperture and assigning individual bits to different portions of the aperture or by overlaying various amplitude gratings at different angles.

Finally we note that although in the spatial diversity scheme discussed above many different phase-modulated points in the transmitter aperture were illuminated, spatial-multiplexing can be accomplished by as few as two points illuminated at any given time. Although for this situation the far-field pattern is a particularly simple class of speckle patterns (e.g., a fringe pattern), message bit assignments can be made on the basis of point (pin-hole) separations and orientations giving rise to fringe patterns in the receiver plane which can be interrogated by many detection schemes to infer corresponding spatial orientation and frequency.

ACKNOWLEDGMENT

The authors gratefully acknowledge the assistance of Mr. Jacob Leeder in the photomultiplier instrumentation.

REFERENCES

1. P.H. Deitz, "Image Information by Means of Speckle-Pattern Processing," *Journal of the Optical Society* 65, pp. 279-285 (1975).
2. US Patent No. 4,085,310; awarded April 18, 1978.

DISTRIBUTION LIST

<u>No. of</u> <u>Copies</u>	<u>Organization</u>	<u>No. of</u> <u>Copies</u>	<u>Organization</u>
12	Commander Defense Documentation Center ATTN: DDC-DDA Cameron Station Alexandria, VA 22314	1	Commander US Army Electronics Research and Development Command Technical Support Activity ATTN: DELSD-L Fort Monmouth, NJ 07703
1	Director Defense Advanced Research Project Agency Tactical Technical Office ATTN: Dr. James Tegnalia 1400 Wilson Boulevard Arlington, VA 22209	1	Commander US Army Communications Rsch and Development Command ATTN: DRDCO-PPA-SA Fort Monmouth, NJ 07703
1	Director Institute for Defense Analysis ATTN: Dr. Bruce J. Whittemore 400 Army Navy Drive Arlington, VA 22202	3	Commander US Army Harry Diamond Labs ATTN: DRXDO-TI DRXDO-SA, Mr. W. Pepper Mr. J. Salerno 2800 Powder Mill Road Adelphi, MD 20783
1	Commander US Army Materiel Development and Readiness Command ATTN: DRCMDM-ST 5001 Eisenhower Avenue Alexandria, VA 22333	1	Director Office of Missile Electronic Warfare ATTN: DRSEL-WLH-SF, Mr. R. J. Clawson White Sands Missile Range, NM 88002
1	Commander US Army Aviation Research and Development Command ATTN: DRSAV-E P.O. Box 209 St. Louis, MO 63166	1	Commander US Army Night Vision and Electro-Optics Laboratory ATTN: DRSEL-NV-VI, Mr. J. Dehne Fort Belvoir, VA 22060
1	Director US Army Air Mobility Research and Development Laboratory Ames Research Center Moffett Field, CA 94035	2	Commander US Army Missile Research and Development Command ATTN: DRDMI-R DRDMI-YDL Redstone Arsenal, AL 35809
1	Director Applied Technology Laboratory US Army Research & Technology Laboratories (AVRADCOM) ATTN: DAVDL Fort Eustis, VA 23604		

DISTRIBUTION LIST

<u>No. of</u> <u>Copies</u>	<u>Organization</u>	<u>No. of</u> <u>Copies</u>	<u>Organization</u>
3	Commander US Army Missile Research and Development Command ATTN: DRDMI-CA, Dr. Donald McDaniels DRDMI-EA, Mr. B. Harwell DRDMI-TKL, Mr. B. Cobb Redstone Arsenal, AL 35809	1	Commander US Army Armament Research and Development Command ATTN: DRDAR-LCB, Mr. M. Dale Watervliet, NY 12189
1	Commander US Army Missile Research and Development Command ATTN: COL Williamson, TOW PM Redstone Arsenal, AL 35809	1	Commander US Army Armament Materiel Readiness Command ATTN: DRSAR-LEP-L, Tech Lib Rock Island, IL 61299
1	Commander US Army Tank Automotive Research & Development Command ATTN: DRDRA-UL Warren, MI 48090	1	Commander US Army Training and Doctrine Command ATTN: ATCG, Dr. Marvin Pastel Fort Monroe, VA 23651
2	Commander US Army Armament Research and Development Command ATTN: DRDAR-TSS Dover, NJ 07801	1	Director US Army TRADOC Systems Analysis Activity ATTN: ATAA-SL, Tech Lib White Sands Missile Range, NM 88002
5	Commander US Army Armament Research and Development Command ATTN: DRDAR-LC, Dr. J. Frasier DRDAR-LCW, Mr. H. Garver DRDAR-LCF, Mr. F. Saxe DRDAR-LCU, Mr. A. Moss Mr. T. Malgeri Dover, NJ 07801	4	Commander US Army Infantry Center ATTN: ATSH-DCG, BG F. Mahaffey Mr. P. Ferguson Mr. G. Hardgrove ATSH-CD-MSD-F, Mr. Ramsey Fort Benning, GA 31905
1	Commander US Army Armament Research and Development Command ATTN: DRCPM-SA, Mr. J. Brooks Dover, NJ 07801	2	Director US Army Infantry Center Antiarmor Weapons Special Task Force ATTN: DAMO-RQD-1 Fort Benning, GA 31905
		1	Commandant US Army Armor School ATTN: Combat Developments Fort Knox, KY 40121

DISTRIBUTION LIST

<u>No. of Copies</u>	<u>Organization</u>	<u>No. of Copies</u>	<u>Organization</u>
1	Deputy Under Secretary of the Army for Operations Research ATTN: Mr. David Hardison Washington, DC 20310	2	General Dynamics Pomona Division ATTN: Mr. L. P. Green P.O. Box 2507 Pomona, CA 91766
2	ADTC/DLMIT (J. Constantine; J. Burda) Eglin AFB, FL 32542	2	Honeywell, Inc. ATTN: Mr. A.C. Hastings Mr. David Erdmann 600 Second Street, North Hopkins, MN 55343
1	AFATL (Dr. J. R. Mayersak, Chief Scientist) Eglin AFB, FL 32542	2	Hughes Aircraft Company Ground Systems Group ATTN: Dr. Wesley K. Masenten Mr. J. Willner P.O. Box 3310 Fullerton, CA 92634
2	Aerojet Electro Systems ATTN: Mr. Keith Paradis 1100 W. Hollyvale Street Azusa, CA 91702	2	Hughes Aircraft Company ATTN: Mr. Ron Sabowski 3100 West Lomita Blvd Torrance, CA 90509
2	Applied Electronics Division AIL - Division of Cutler- Hammer ATTN: Mr. Theodore Flattau Melville, L.I., NY 11746	1	Martin Marietta Corporation Orlando Division ATTN: Mr. Joseph Stever P.O. Box 5837 Orlando, FL 32855
2	AVCO Systems Division ATTN: Mr. Thomas Midura 201 Lowell Street Wilmington, MA 01887	1	Raytheon Company Missile Systems Division ATTN: Mr. Thomas Crocker Bedford, MA 01730
1	Bolt Beranek & Newman Inc. ATTN: Mr. Richard Barakat Cambridge, MA 02138	1	Sanders Associates Inc. Federal Systems Group ATTN: Mr. Tommy E. Buder, NCA1-6228 95 Canal Street Nashua, NH 03061
2	Cincinnati Electronics ATTN: Mr. Robert Seitz Mr. Raymond Schmidt 2630 Glendale-Milford Road Cincinnati, OH 45241	1	SINGER - Kearfott Division ATTN: Mr. Myron Rosenthal 150 Totwa Road Wayne, NJ 07470
2	Environmental Research Institute of Michigan ATTN: Mr. Jerry Beard P.O. Box 8618 Ann Arbor, MI 48107		

DISTRIBUTION LIST

<u>No. of Copies</u>	<u>Organization</u>	<u>Aberdeen Proving Ground</u>
1	System Planning Corporation Suite 1500 ATTN: Dr. James Meni 1500 Wilson Boulevard Arlington, VA 22209	Dir, USAMSAA ATTN: Dr. J. Sperrazza DRXSY-MP, Mr. H. Cohen DRXSY-GI, Mr. W. Clifford DRXSY-DS, Mr. J. Kramar DRXSY-T, Mr. A. Reid DRXSY-G, Mr. R. Conroy Mr. C. Odom
1	University of California Lawrence Livermore Laboratory ATTN: Mr. R. Singleton P.O. Box 808 Livermore, CA 94550	Dir, HEL ATTN: Mr. J. Torre Mr. G. L. Horley CDR, USATECOM ATTN: DRSTE-TO-F Dir, Wpns Sys Concepts Team Bldg E3516, EA ATTN: DRDAR-ACW

USER EVALUATION OF REPORT

Please take a few minutes to answer the questions below; tear out this sheet and return it to Director, US Army Ballistic Research Laboratory, ARRADCOM, ATTN: DRDAR-TSB, Aberdeen Proving Ground, Maryland 21005. Your comments will provide us with information for improving future reports.

1. BRL Report Number _____

2. Does this report satisfy a need? (Comment on purpose, related project, or other area of interest for which report will be used.)

3. How, specifically, is the report being used? (Information source, design data or procedure, management procedure, source of ideas, etc.) _____

4. Has the information in this report led to any quantitative savings as far as man-hours/contract dollars saved, operating costs avoided, efficiencies achieved, etc.? If so, please elaborate.

5. General Comments (Indicate what you think should be changed to make this report and future reports of this type more responsive to your needs, more usable, improve readability, etc.) _____

6. If you would like to be contacted by the personnel who prepared this report to raise specific questions or discuss the topic, please fill in the following information.

Name: _____

Telephone Number: _____

Organization Address: _____

