

AD-A074 336

STANFORD UNIV CA DIV OF APPLIED MECHANICS
STEADY-STATE POINT-SOURCE EXCITATION OF A LAMINATED COMPOSITE.(U)
JUN 79 G S BEAUPRE, G, HERRMANN

F/G 11/4

N00014-76-C-0054

UNCLASSIFIED

SUDAM-79-3

NL

1 of 1

AD
AO 743 336

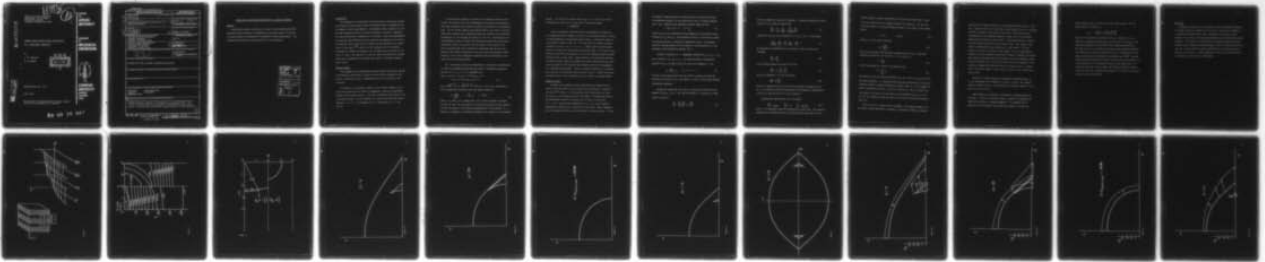

END

DATE
FILMED

-10-19

DDC

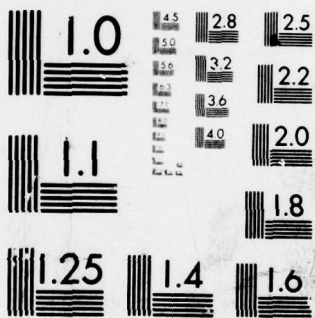

MICROCOPY RESOLUTION TEST CHART
NATIONAL BUREAU OF STANDARDS-1963-A

LEVEL

10

Office of Naval Research
Department of the Navy
Scientific Report
Contract N00014-76-C-0054

DIVISION
OF
**APPLIED
MECHANICS**

AD A 074336

STEADY-STATE POINT-SOURCE EXCITATION
OF A LAMINATED COMPOSITE

DEPARTMENT
OF
**MECHANICAL
ENGINEERING**

by
G. S. Beaupre
G. Herrmann

DDC
RECEIVED
SEP 27 1979
E



**STANFORD
UNIVERSITY**
STANFORD,
CALIFORNIA
94305

SUDAM Report No. 79-3

June 1979

This document has been approved for public release
and sale; its distribution is unlimited.

DDC FILE COPY

79 09 26 007

UNCLASSIFIED

SECURITY CLASSIFICATION OF THIS PAGE (When Data Entered)

REPORT DOCUMENTATION PAGE		READ INSTRUCTIONS BEFORE COMPLETING FORM
1. REPORT NUMBER 14 SUDAM-79-31	2. GOVT ACCESSION NO.	3. RECIPIENT'S CATALOG NUMBER
4. TITLE (and Subtitle) 6 STEADY-STATE POINT-SOURCE EXCITATION OF A LAMINATED COMPOSITE.	5. TYPE OF REPORT & PERIOD COVERED 9 INTERIM / rept.	6. PERFORMING ORG. REPORT NUMBER
7. AUTHOR(s) 10 G.S. BEAUPRE G. HERRMANN	8. CONTRACT OR GRANT NUMBER(s) 15 N00014-76-C-0054	9. PROGRAM ELEMENT, PROJECT, TASK AREA & WORK UNIT NUMBERS ONR:474
9. PERFORMING ORGANIZATION NAME AND ADDRESS DIVISION OF APPLIED MECHANICS STANFORD UNIVERSITY STANFORD, CALIFORNIA 94305	11. CONTROLLING OFFICE NAME AND ADDRESS OFFICE OF NAVAL RESEARCH DEPARTMENT OF THE NAVY ARLINGTON, VIRGINIA 22217 11	12. REPORT DATE JUNE 1979 13. NUMBER OF PAGES 26
14. MONITORING AGENCY NAME & ADDRESS (if different from Controlling Office) 12 26 p. 1	15. SECURITY CLASS. (of this report) UNCLASSIFIED	15a. DECLASSIFICATION/DOWNGRADING SCHEDULE
16. DISTRIBUTION STATEMENT (of this Report) APPROVED FOR PUBLIC RELEASE; DISTRIBUTION UNLIMITED		
17. DISTRIBUTION STATEMENT (of the abstract entered in Block 20, if different from Report)		
18. SUPPLEMENTARY NOTES		
19. KEY WORDS (Continue on reverse side if necessary and identify by block number) COMPOSITES WAVE PROPAGATION LAMINATES DISPERSION GEOMETRIC OPTICS		
20. ABSTRACT (Continue on reverse side if necessary and identify by block number) Steady-state periodic excitation at a point of an extended periodically laminated elastic composite is considered in anti-plane strain. The curves of constant phase are determined in the geometric optics approximation. The associated distribution of group velocity is also calculated.		

DD FORM 1473 1 JAN 73

EDITION OF 1 NOV 65 IS OBSOLETE S/N 0102-LF 014-6601

09 UNCLASSIFIED 008

SECURITY CLASSIFICATION OF THIS PAGE (When Data Entered)

710 3.89

Handwritten mark resembling a stylized 'A' or 'M'.

Handwritten signature or initials.

STEADY-STATE POINT-SOURCE EXCITATION OF A LAMINATED COMPOSITE

Abstract

Steady-state periodic excitation at a point of an extended periodically laminated elastic composite is considered in anti-plane strain. The curves of constant phase are determined in the geometric optics approximation. The associated distribution of group velocity is also calculated.

Accession For	
NTIS GRA&I	<input checked="" type="checkbox"/>
DBC TAB	<input type="checkbox"/>
Unannounced	<input type="checkbox"/>
Justification	<input type="checkbox"/>
By _____	
Distribution/ _____	
Availability Codes	
Dist	Avail and/or special
A	

Introduction

The propagation of horizontally polarized harmonic shear waves through a periodically layered elastic body of unbounded extent is examined here in the geometric optics approximation. The geometric optics approach is valid for high frequencies where the relevant wavelength is small in comparison with some characteristic dimension of the problem. Under this approximation any quantity which describes the wave field can be expressed in the form of an amplitude, which varies slowly in space and time, multiplied by a phase factor of the form $e^{-i\Omega S}$, where Ω is the frequency and S is the phase. Following the notation of reference [1], the phase S can be written in the form $S = t - \sigma(x)$. The surfaces $S = \text{constant}$, which are surfaces of constant phase will be examined for the steady state case of a constant frequency point source.

Infinite Medium

The propagation of horizontally polarized harmonic shear waves through a periodically layered body of infinite extent has been analyzed in some detail in reference [2] and is summarized here as far as needed in the following.

The system to be considered consists of an infinite sequence of two alternating layers, each of which is homogeneous, isotropic and perfectly bonded to the adjoining layers. A unit cell is defined as the union of any two adjacent layers. The two lamellae of a typical unit cell have elastic constants $\lambda, \mu; \lambda', \mu'$, thicknesses $2h; 2h'$, and densities $\rho; \rho'$, see Fig. 1a.

By utilizing the equations of elasticity and imposing continuity conditions, which specify that the displacements and stresses are continuous at each layer interface, we can write the equation of motion for the laminated body. For the infinite medium this equation takes on the form of a partial differential equation with coefficients which are periodic in the direction perpendicular to the layering with period $d = 2h + 2h'$. Application of the one-dimensional theory of Floquet for differential equations with periodic coefficients leads to the result that the details of the motion of the entire laminated body can be obtained by considering only one unit cell. Therefore the boundary conditions for one unit cell using Floquet's theory represent a set of four homogeneous equations which are sufficient to describe the entire laminated body.

For a nontrivial solution the determinant of the matrix of coefficients of these four homogeneous equations must vanish, yielding the dispersion equation $H'(\Omega, \eta, \zeta) = 0$ or in expanded form

$$4\gamma\alpha\alpha' \cos \pi\eta(1 + \varepsilon) + (\gamma\alpha - \alpha')^2 \cos \pi(\alpha - \varepsilon\alpha') - (\gamma\alpha + \alpha')^2 \cos \pi(\alpha + \varepsilon\alpha') = 0 \quad (1)$$

Here $\alpha = \sqrt{\Omega^2 - \zeta^2}$, $\alpha' = \sqrt{\sigma^2 \Omega^2 - \zeta^2}$, where Ω , ζ , and η are, respectively, the nondimensional frequencies and wave numbers defined by

$$\Omega = \frac{2h\omega}{\pi\sqrt{\mu/\rho}}; \quad \zeta = \frac{2h}{\pi} k_z; \quad \eta = \frac{2h}{\pi} k_y \quad (2)$$

where ω , k_z , and k_y are, respectively, the circular frequency in radians per unit of time, the wave number in the direction parallel to the layering, and the wave number in the direction perpendicular to the layering. In addition, the geometric and material parameters are defined in the following

manner: γ is the ratio of shear moduli (μ/μ'), ϵ is the ratio of layer thicknesses ($2h'/2h$), and σ is the ratio of shear wave speeds

$$\sigma = \sqrt{\mu\rho'/\mu'\rho}$$

Since the dispersion equation related a nondimensional frequency to two nondimensional wave numbers, the roots of this equation define a surface in three-dimensional frequency-wave number space. A qualitative sketch of this surface is shown in Fig. 1b. It is seen that the surface is discontinuous at $\eta = n/(1 + \epsilon)$, $n = 1, 2, 3, \dots$. These planes of discontinuity divide the surface into bands known as Brillouin zones. At the end of each Brillouin zone (with the exception of $\eta = 0$) the dispersion equation admits complex as well as real roots. These portions of the dispersion spectrum for which the wave numbers are complex are called stopping bands and correspond to regions of the spectrum where harmonic waves are not propagated but attenuated exponentially. Curves of constant frequency on the surface over the first two Brillouin zones are shown in Fig. 2. These curves play an important part in the construction of the surfaces of constant phase.

Geometric Optics

Introducing the geometric optics approximation we assume that any quantity which describes the wave field can be expressed by a formula of the type $Ae^{-i\Omega S}$ where A is the amplitude, which varies slowly in space and time, Ω is the frequency, and S is the phase. Following the notation and methodology outlined in reference [1], we write S in the form $S = t - \sigma(x)$. The wavefronts defined by $S(x, t) = 0$ can be found by examining the surfaces $\sigma(x) = \text{constant}$ for fixed time. These "snapshots" give the successive positions of the wavefront in physical space. To find

the shape of these wavefronts in physical space we begin by rewriting the dispersion equation for the steady state case of a single frequency, say $\Omega = \Omega_0$. Doing this the dispersion relation takes the form

$$H(p_1, p_2) = 0 \quad p_i = \sigma_{x_i} \quad (3)$$

where the p_i can be interpreted as the components of the slowness vector defined by η/Ω_0 and ζ/Ω_0 . The dispersion relation in this form is called the eikonal equation or equation of geometrical optics. The standard method of solving equation (3) is by means of the characteristic or ray equations, which proceeds as follows, ref. 1:

Consider an equation in n independent variables $(x_1, x_2, x_3, \dots, x_n)$ and a function $\sigma(x_1, x_2, x_3, \dots, x_n)$ which satisfies a differential equation $H(\underset{\sim}{p}, \underset{\sim}{\sigma}, \underset{\sim}{x})$ where $\underset{\sim}{p}$ and $\underset{\sim}{x}$ are vectors of dimension n and

$$p_i \equiv \frac{\partial \sigma}{\partial x_i} = \sigma_{x_i} \quad i = 1, 2, 3 \dots n \quad (4)$$

We wish to find whether there are any curves in x -space for which the differential equation $H(\underset{\sim}{p}, \underset{\sim}{\sigma}, \underset{\sim}{x})$ reduces to a set of first order ordinary differential equations.

We begin by noting that any curve in x -space may be written in the parametric form $\underset{\sim}{x} = \underset{\sim}{x}(\lambda)$. The total derivative of σ along one of these curves is given by

$$\frac{d\sigma}{d\lambda} = \frac{\partial \sigma}{\partial x_i} \frac{dx_i}{d\lambda} = p_i \frac{dx_i}{d\lambda} \quad (5)$$

where the summation convention is employed. In addition consider the total derivative of p_i along the same curve

$$\frac{dp_i}{d\lambda} = \frac{d}{d\lambda} \left(\frac{\partial \sigma}{\partial x_i} \right) = \frac{\partial^2 \sigma}{\partial x_i \partial x_j} \frac{dx_j}{d\lambda} \quad (6)$$

Finally let us take the x_i derivative of $H(\underline{p}, \sigma, \underline{x}) = 0$ which gives

$$\frac{\partial^2 \sigma}{\partial x_i \partial x_j} \frac{\partial H}{\partial p_j} + \frac{\partial H}{\partial \sigma} \frac{\partial \sigma}{\partial x_i} + \frac{\partial H}{\partial x_i} = 0 \quad (7)$$

By choosing as our definition for the special curves in x -space the following

$$\frac{dx_i}{d\lambda} = \frac{\partial H}{\partial p_i} \quad (8)$$

we may combine equations (6) and (7) to give

$$\frac{dp_i}{d\lambda} = -p_i \frac{\partial H}{\partial \sigma} - \frac{\partial H}{\partial x_i} \quad (9)$$

The use of equation (7) in (4) then yields

$$\frac{d\sigma}{d\lambda} = p_i \frac{\partial H}{\partial p_i} \quad (10)$$

The set of equations (8), (9) and (10) now represents a complete set of $(2n + 1)$ ordinary differential equations for determining a characteristic curve $x_i(\lambda)$ and the values of σ and p_i along it.

Specializing these results to our case gives

$$\frac{dx_i}{d\lambda} = (\underline{\nabla} H)_i; \quad \frac{dp_i}{d\lambda} = 0; \quad \frac{d\sigma}{d\lambda} = (\underline{p} \cdot \underline{\nabla} H) \quad (11)$$

where λ is a parameter along the characteristic curve (ray). The second of equations (11) indicates that p_i are constant along rays, hence the ray

direction $\nabla_p H$ is constant and therefore the rays are straight lines. Since the p_i are constant we can integrate equation (11) directly. For the case of a point source of constant frequency located at the origin, we can readily obtain,

$$x_i = l_i s \quad \sigma = p \cdot \underline{\underline{l}} s \quad (12)$$

where $\underline{\underline{l}}$ is a unit vector defined by

$$\underline{\underline{l}} = \frac{\nabla_p H}{\|\nabla_p H\|} \quad (13)$$

and s is the distance from the source measured along the ray. From these equations we find that the wavefront $S = 0$ is located at

$$s = \frac{t}{p \cdot \underline{\underline{l}}} \quad (14)$$

and the coordinates of a point on the wavefront are

$$x_i = \frac{t}{p \cdot \underline{\underline{l}}} l_i \quad (15)$$

By varying p_i over all values satisfying $H(p_1, p_2) = 0$ for $\Omega = \Omega_0$ we can find the entire wavefront. It should be noted that these wavefronts can be found by examining curves of constant frequency in p -space (Fig. 2). If for example we choose a particular value for Ω , say 0.9, (see Fig. 3), then $\underline{\underline{l}}$ is merely the unit normal to the curve for any choice of p_i satisfying $H(p_1, p_2) = 0$ for $\Omega = 0.9$. By varying p_i along the curve we can trace out the entire wavefront (Fig. 4a).

With the aid of a compass and two triangles a very simple geometric construction of these wavefronts is possible. We begin by drawing a coordinate

system with the same orientation as the coordinate system in Fig. 2. From Fig. 2 choose a value for Ω and select a point along the curve $\Omega = \text{constant}$. Now draw the normal to the curve at this point. With the aid of the triangles draw a line passing through the origin of our new coordinate system which is parallel to this normal. Now working with Fig. 2 project the wave number vector onto the unit normal vector. The length of this vector is proportional to $\underline{p} \cdot \underline{\ell}$ (since $\underline{\ell}$ is a unit vector). All that remains is to take the inverse of this length. This is accomplished by drawing a reference hyperbola and using the compass to measure the inverse. This length is then measured from the origin of our new coordinate system along the parallel to $\underline{\ell}$. This is the first point of the wavefront. The process is repeated for different points on the same curve $\Omega = \text{constant}$ until a sufficient number of points exist in order to pass a smooth curve through them.

Because the eikonal equation is unchanged by switching from p_1 to $-p_1$ the wavefronts will be symmetric in the x_1, x_2 axis. The complete picture is shown in Fig. 5. The wavefronts for different values of Ω are shown in Fig. 4b, 4c, 4d.

These figures of course give no information concerning energy distribution. It may be of interest, though, to examine the magnitude and direction of velocity of energy propagation. To accomplish this a numerical finite difference calculation was carried out to show the

group velocity vector at points on the zero phase curves. Here the group velocity is defined as:

$$\tilde{c}_g = - \left(\frac{\partial H'}{\partial \eta} \tilde{e}_\eta + \frac{\partial H'}{\partial \zeta} \tilde{e}_\zeta \right) / \frac{\partial H'}{\partial \Omega}$$

where H' is the dispersion relation written as a function of Ω , ζ , η which were previously defined and \tilde{e}_η , \tilde{e}_ζ which are unit vectors in the direction perpendicular and parallel to the layering, respectively. The Figs. 6a, 6b, 6c, 6d duplicate the phase curves previously shown, but now include group velocity information as well. The magnitude of the group velocity vector normalized by the phase velocity $\sqrt{\mu/\rho}$ is drawn radially outward from each zero phase curve where the vectors begin, not at the origin but at the appropriate point on each phase curve. It should be noted that the zero phase curve passing through the conical point (Fig. 6c) has a pointwise discontinuity in the value of the group velocity at the conical point.

Conclusion

Through the utilization of the geometric optics approximation surfaces of constant phase were examined for the case of a point source imbedded in a periodically layered elastic body. Knowledge of the shape of these surfaces is the first step toward understanding how more complicated signals propagate. For instance, we already know from examining these zero phase surfaces that an observer stationed somewhere within the medium would detect one, two, or three distinct signals depending upon ones orientation with respect to the source. A similar phenomenon occurs in the case described in reference [1] for waves in a MHD plasma.

Acknowledgment

The authors are most grateful to Professor J. B. Keller for many valuable discussions and suggestions. This research was supported in part by ONR Contract N00014-76-C-0054.

References

1. Whitman, G. B., Linear and Nonlinear Waves, Wiley, New York, pp 65-67 and 235-262, 1974.
2. Delph, T. J., Herrmann, G. and Kaul, R. K., "Harmonic Wave Propagation in a Periodically Layered, Infinite Elastic Body: Antiplane Strain," Journal of Applied Mechanics, 45 (1978) 343-349.
3. Landau, L. B. and Lifshitz, E. M., Electrodynamics of Continuous Media, Pergamon, New York, p 269, 1960.
4. Delph, T. J., Herrmann, G. and Kaul, R. K., "On Coalescence of Frequencies and Conical Points in the Dispersion Spectra of Elastic Bodies", Int. J. Solids Structures, 13 (1977) 423-436.
5. Keller, J. B., Private communication.

Caption of Figures

- Fig. 1a, b Geometry and antiplane dispersion surface for layered elastic solid.
- Fig. 2 Curves of constant Ω on the antiplane strain dispersion surface.
- Fig. 3 Curve of $\Omega = 0.9$ showing vectors \underline{p} and $\underline{\ell}$.
- Fig. 4a, b, c, d Curves of constant phase for different values of Ω .
- Fig. 5 Complete wavefront for $\Omega = 1.0$.
- Fig. 6a, b, c, d Distribution of group velocity on curves of constant phase.

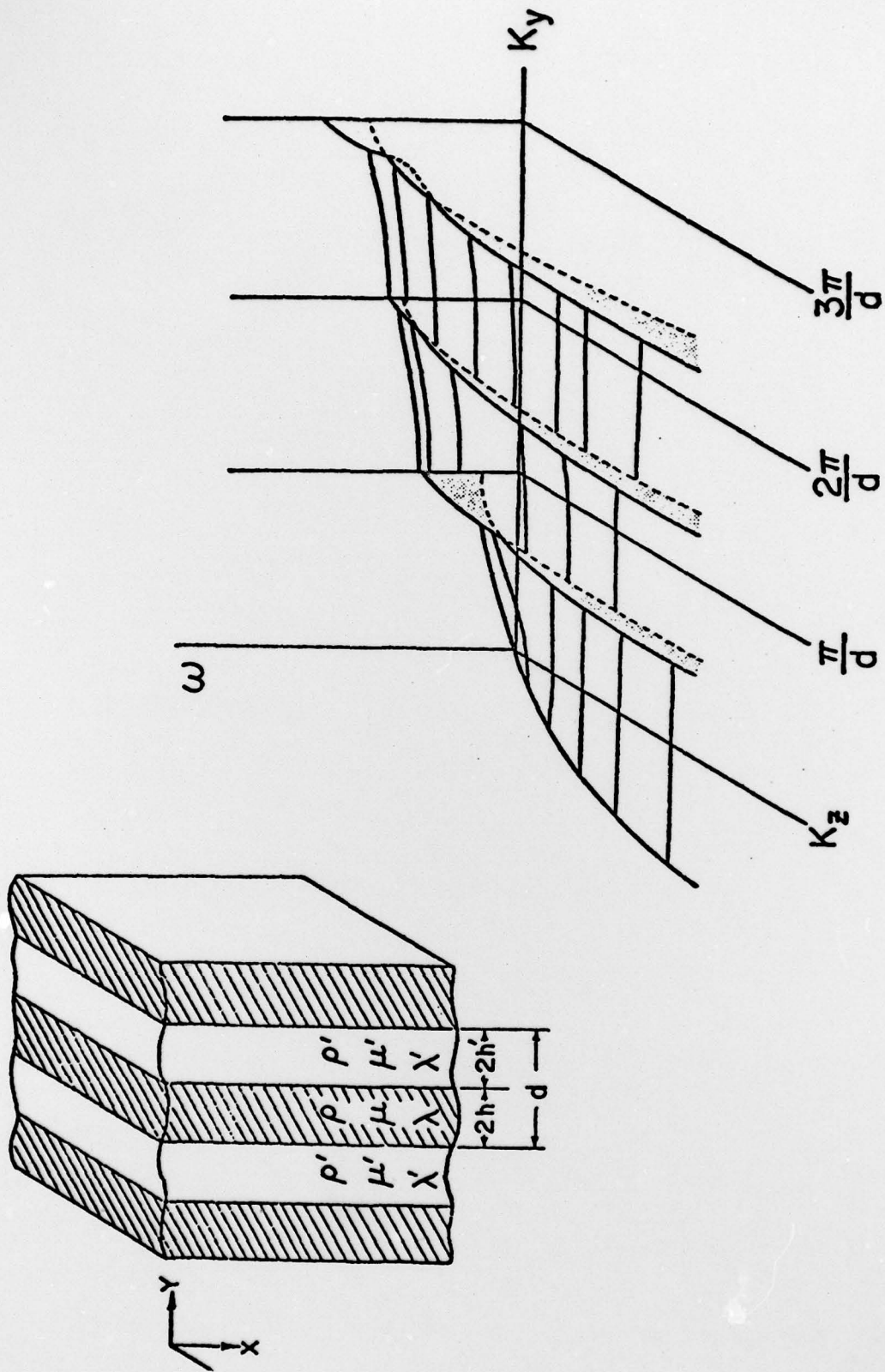

Figure 1

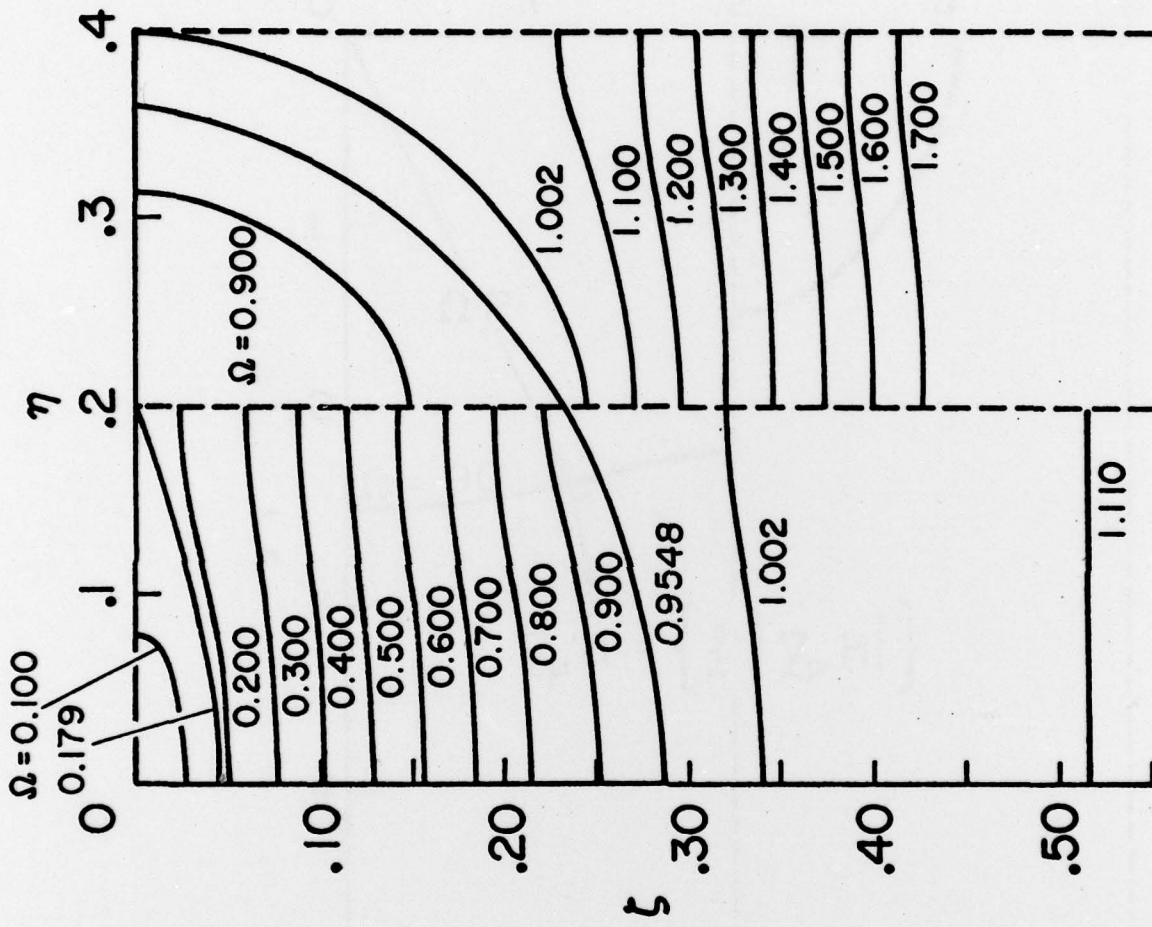

Figure 2

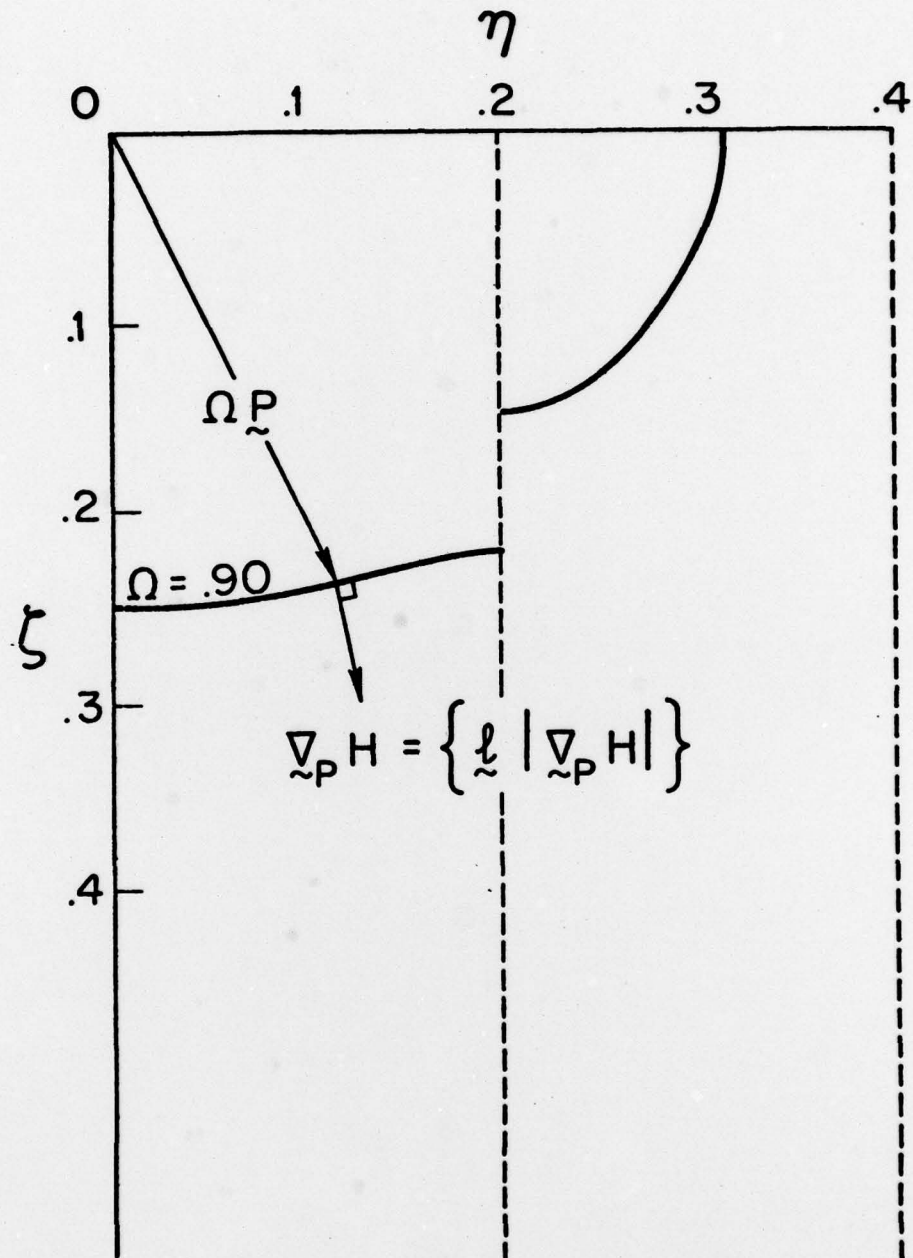

Figure 3

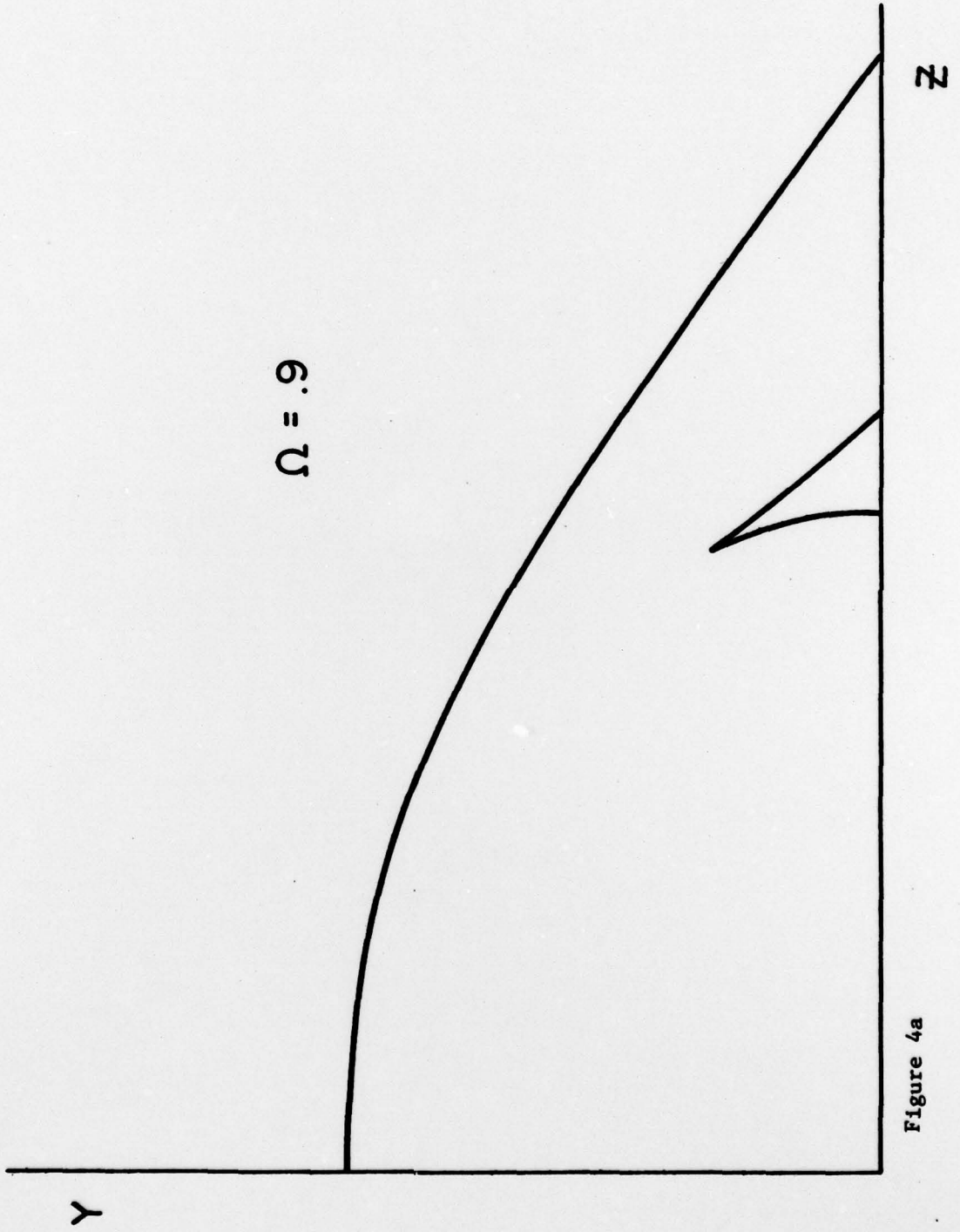

Figure 4a

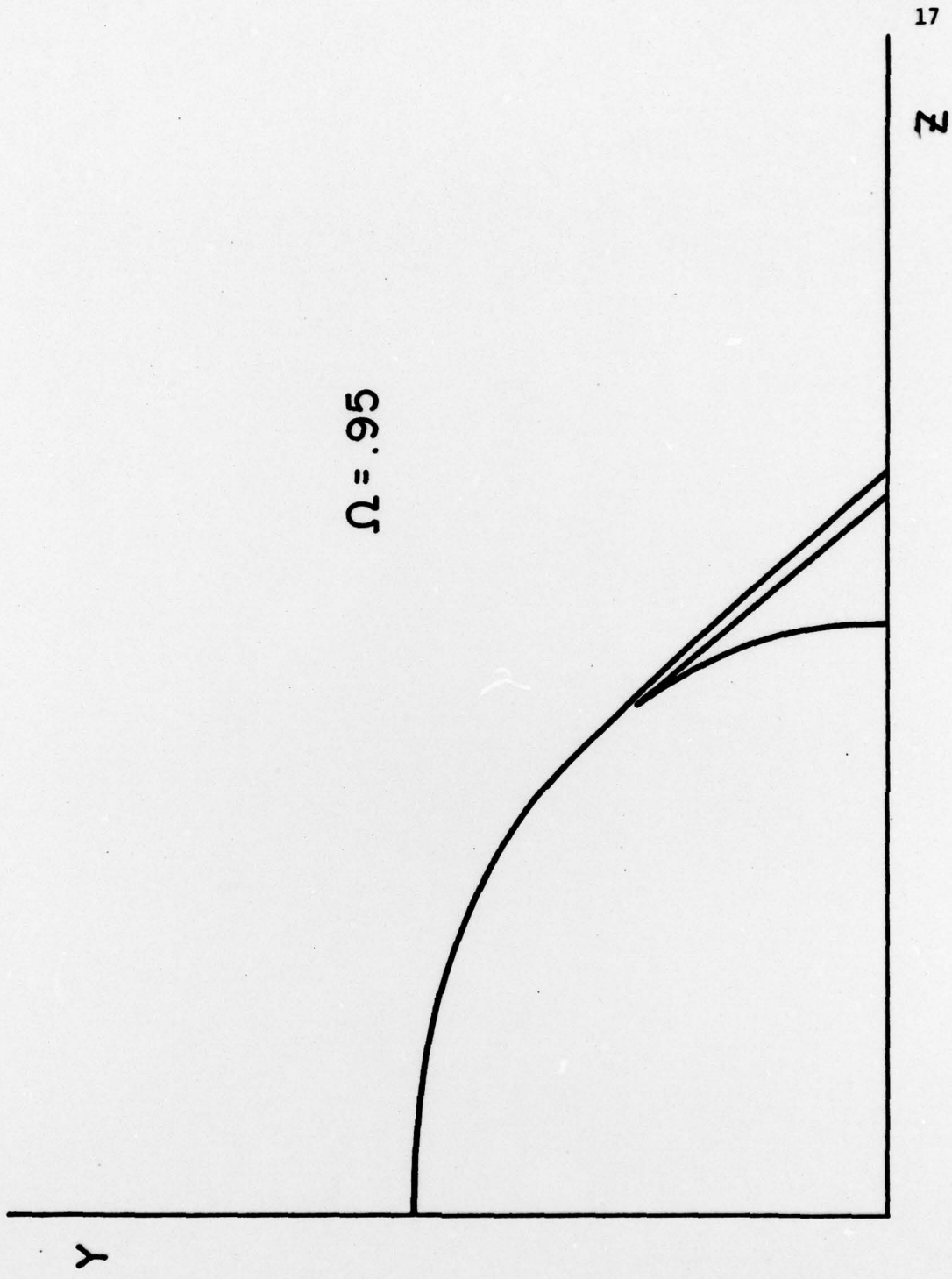

Figure 4b

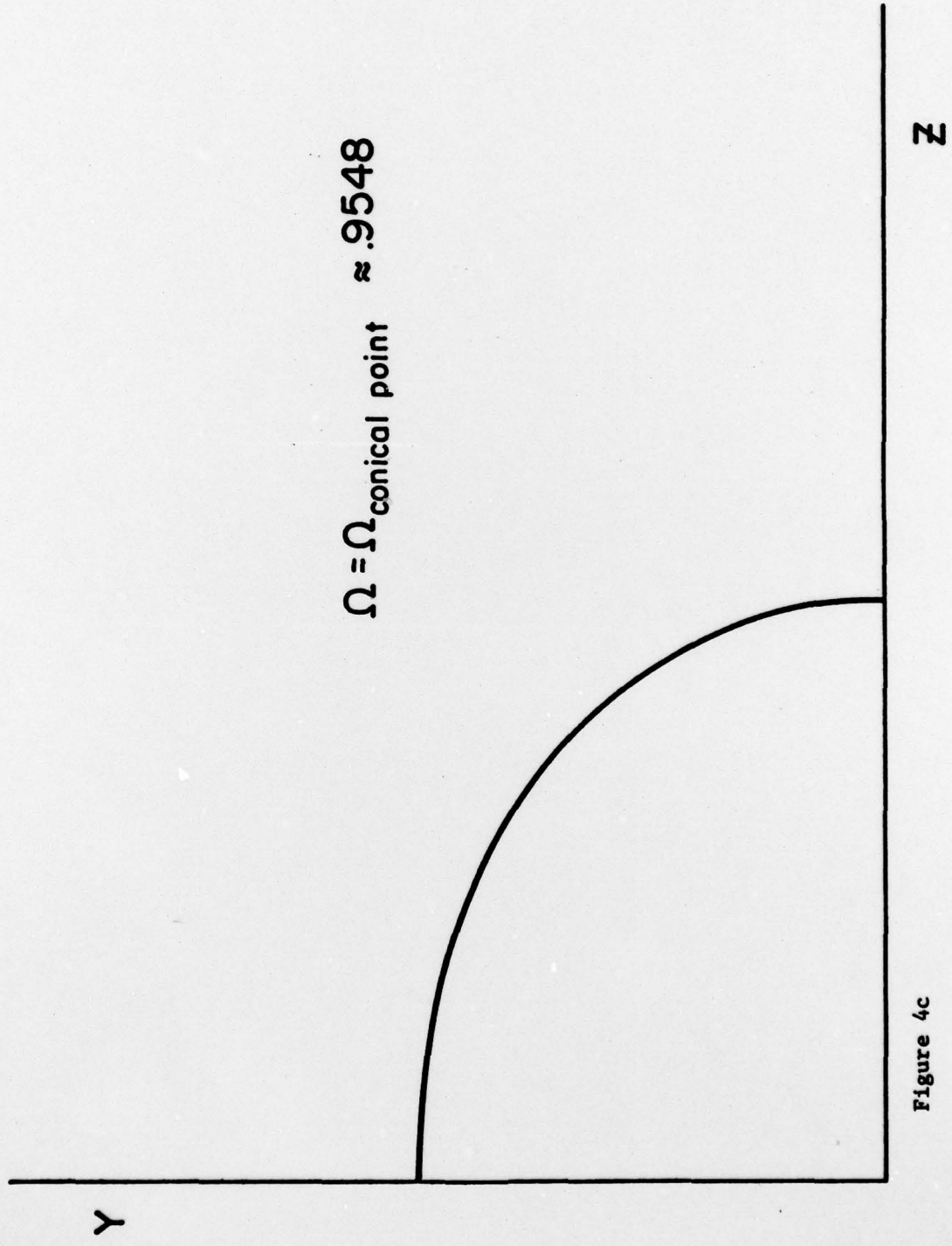

Figure 4c



Figure 4d

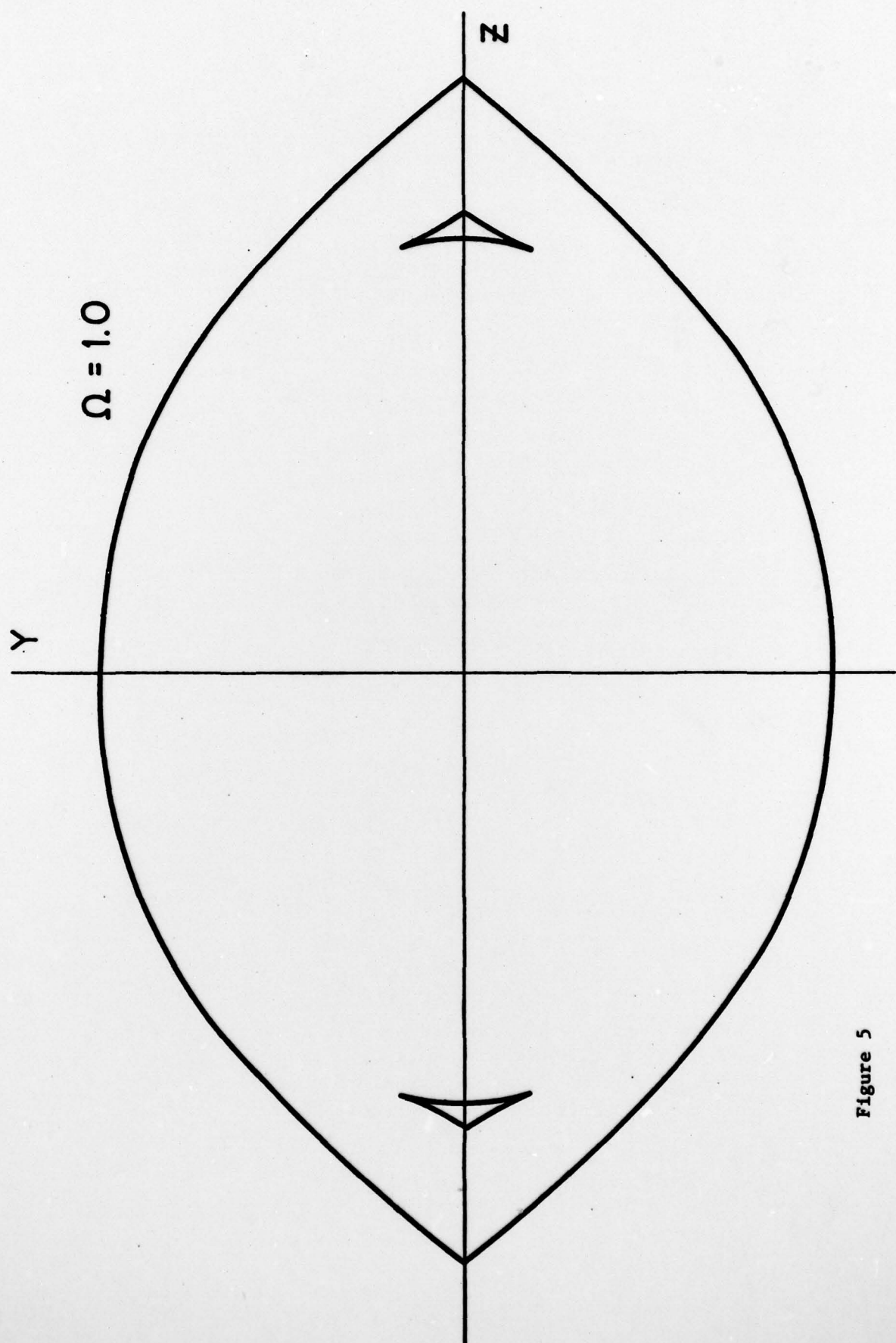

Figure 5

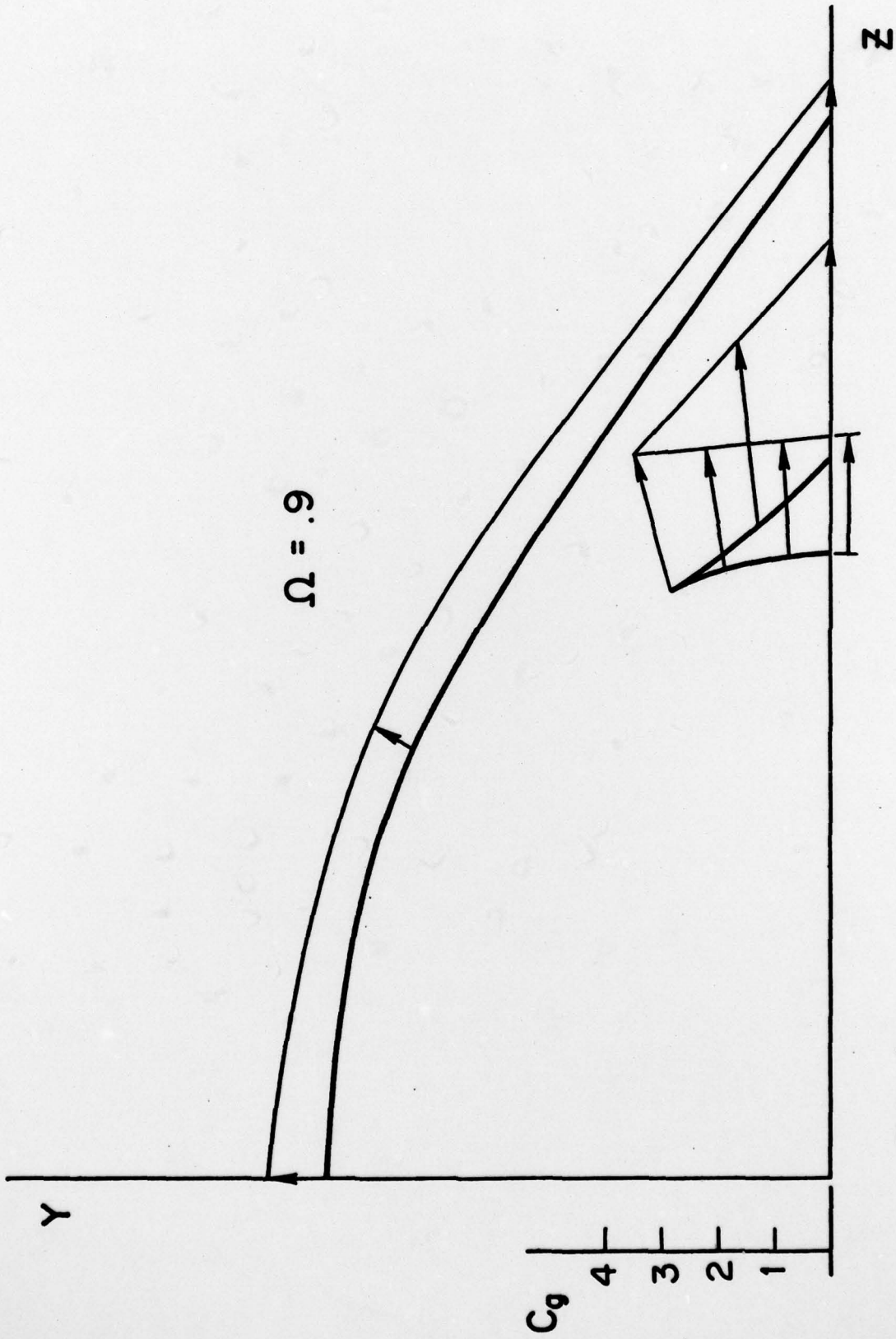

Figure 6a

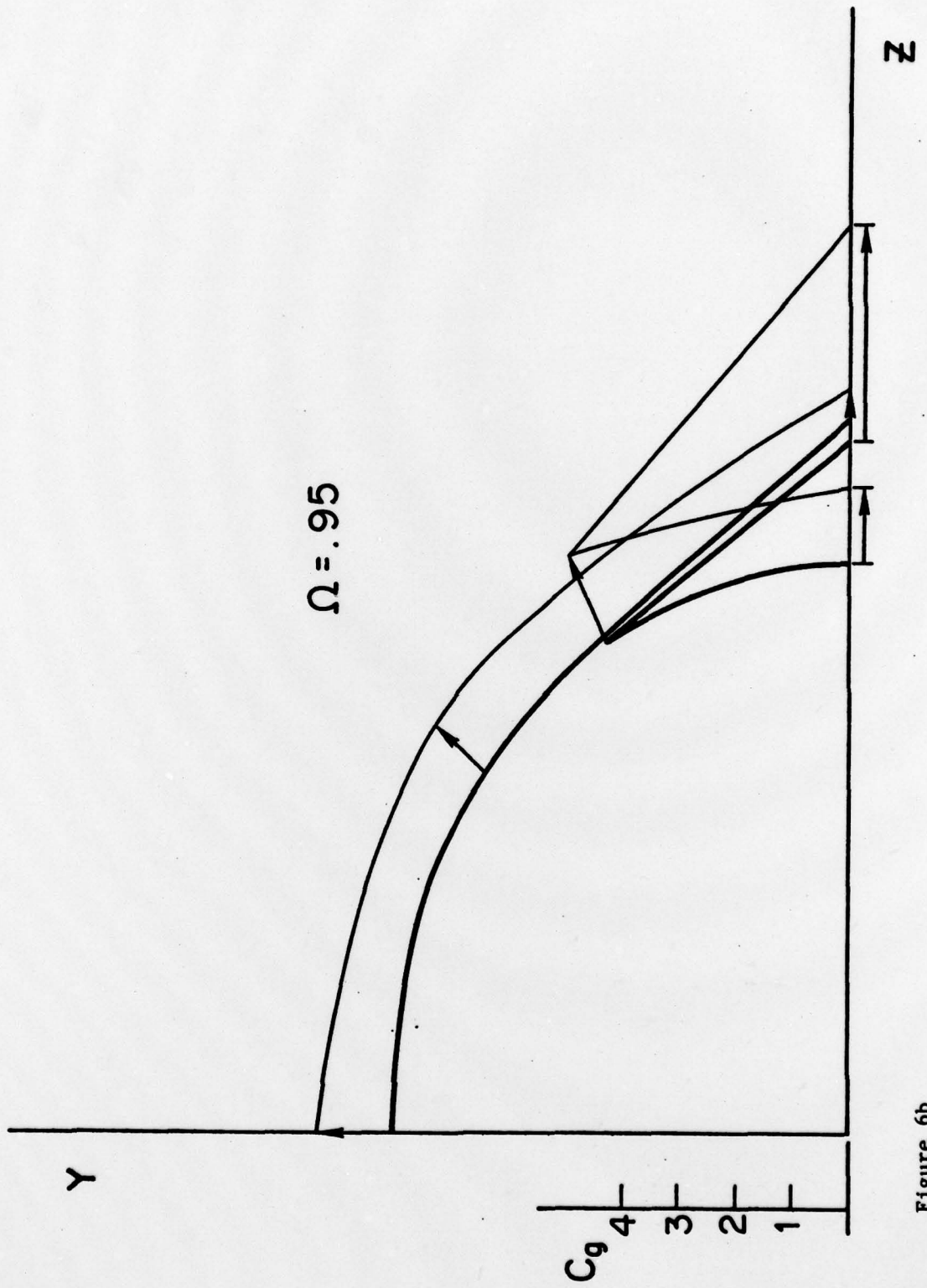

Figure 6b

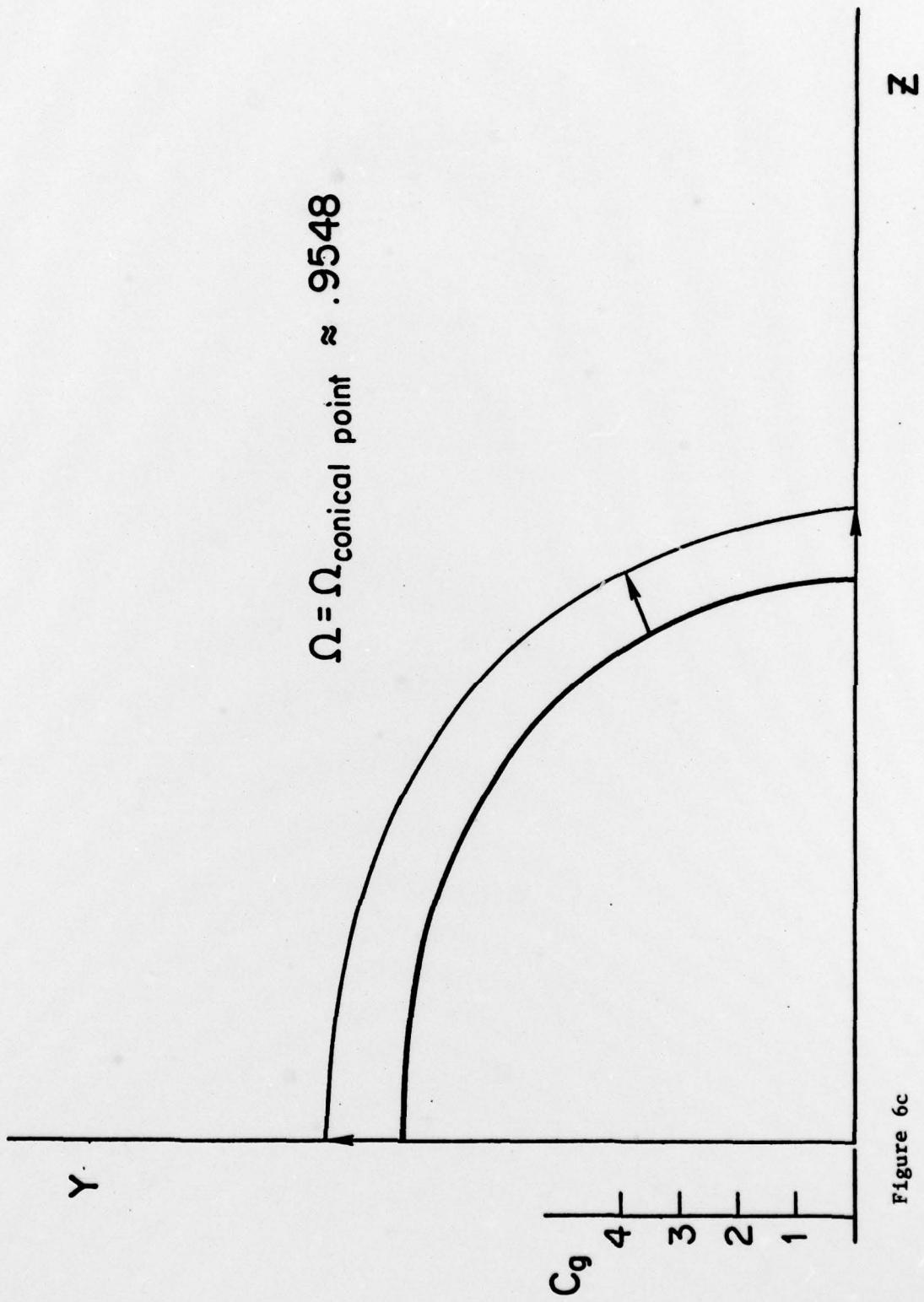

Figure 6c

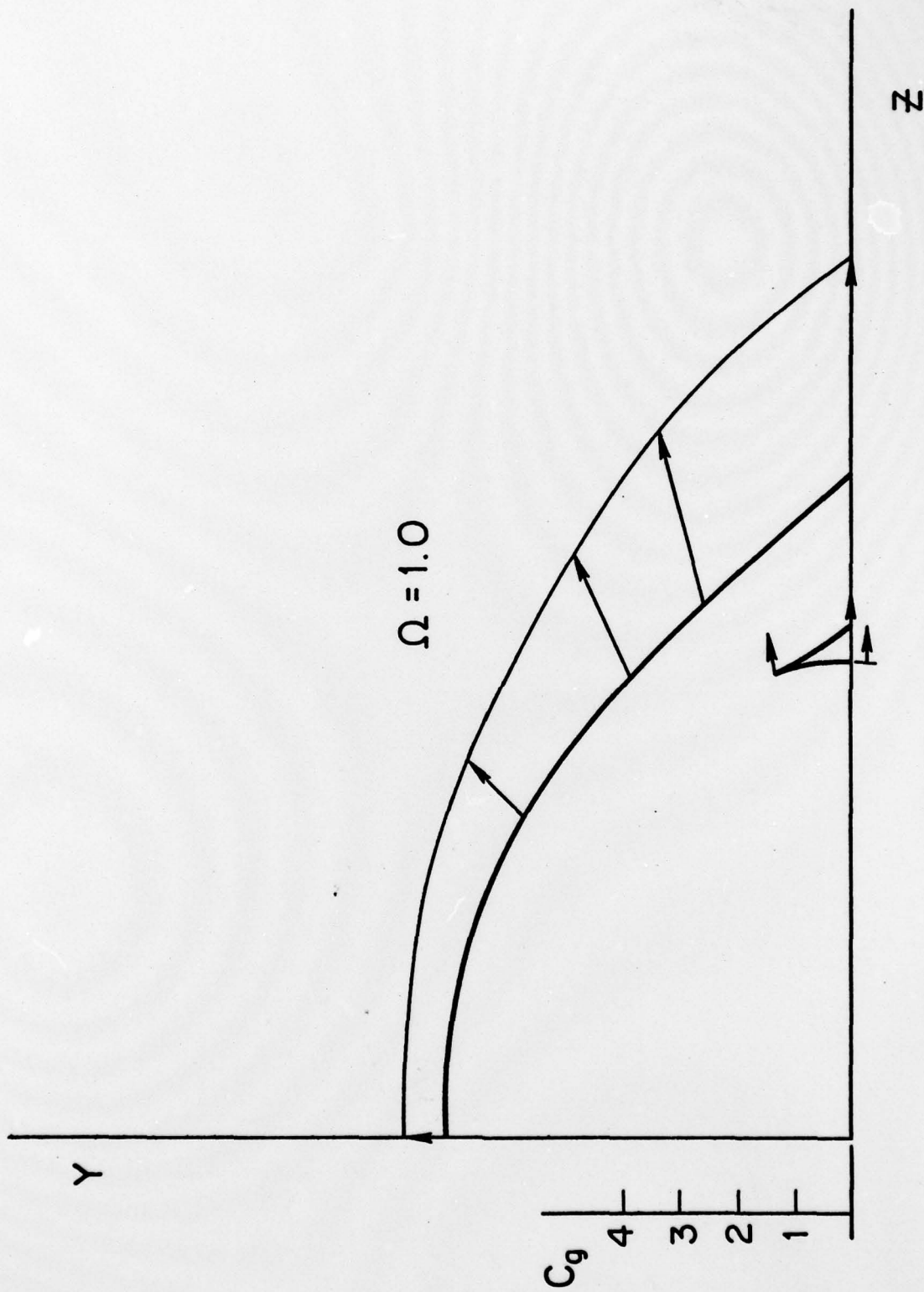

Figure 6d