

AD-A074 400

NAVAL ORDNANCE TEST STATION PASADENA CALIF  
A TORSIONAL DELAY-LINE MATCHED FILTER FOR FIXED-LENGTH BINARY C--ETC(U)  
JUN 65 H J WHITEHOUSE, G F LINDSAY

F/G 9/5

UNCLASSIFIED

IDP-2340

NL

1 OF 1  
AD-  
A074400



END  
DATE  
FILMED  
11-79  
DDC

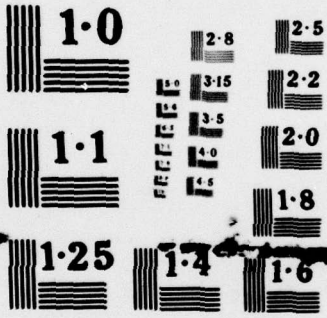

NATIONAL BUREAU OF STANDARDS  
MICROCOPY RESOLUTION TEST CHART

003604  
Good S

MOST Project -3

(14) IDP-2348

LEVEL II

(6)

A TORSIONAL DELAY-LINE MATCHED FILTER  
FOR FIXED-LENGTH BINARY CODES

ADA074400

(10)

by

Harper John Whitehouse  
~~and~~  
George F. Lindsay

(1)

(11)

2 Jun 65

(12)

24p.

DWG FILE COPY

DISTRIBUTION STATEMENT A  
Approved for public release  
Distribution Unlimited

U. S. Naval Ordnance Test Station  
Pasadena, California

June 2, 1965

88-14

✓ 401 496 ENCLOSURE (2)

JB

ABSTRACT

A torsional delay-line matched filter for fixed-length binary codes has been designed for use as an electronic signal processor. The filter is made from a torsional magnetostrictive delay line and permanent magnets. It operates at a bit rate of 1 Mc and, when used in conjunction with a time compression loop, may be used in real time. The signal processor will operate with input signals having bandwidths of 500 kc or less. The number of values of the signal's parameter which may be processed is determined by the time compression ratio. A filter constructed with 512 bits provided a measured processing gain of greater than 25 db against band-limited Gaussian noise. The filter's code may be arbitrarily selected and may be conveniently changed.

Accession For	
NTIS GPO&I	<input checked="" type="checkbox"/>
DCC TAB	<input type="checkbox"/>
Unannounced	<input type="checkbox"/>
Justification	
By <i>Littler on file</i>	
Distribution/	
Availability Codes	
Dist.	Avail and/or special
<i>A</i>	

## INTRODUCTION

Correlators and matched filters have been used for many detection problems, primarily in the field of radar, because of the improved performance they have in the detection of known signals in the presence of noise. Siebert (Ref. 1) describes the radar detection philosophy. Anderson (Ref. 2) has described a delay-line time compressor (DELTIC) correlator which may be implemented with magnetostrictive delay lines. Perzley and Fishbein (Ref. 3) have described an effect in magnetostrictive torsional delay lines which may be used for the construction of high-speed, high-capacity correlators and matched filters. The possibility of using the torsional delay-line effect as a correlator has been described by Whitehouse (Ref. 4).

A compact electronic signal processor has been constructed by the authors using a torsional magnetostrictive delay line which acts as a matched filter for a 512-bit binary code. The torsional delay-line matched filter operates at a bit rate of 1 Mc, and processes a signal continuously for many different values of the signal's parameter.

## OPERATION

The operation of the delay-line matched filter is illustrated in Fig. 1. Longitudinal stress waves of opposite polarity are generated in each of two nickel ribbons by means of the Joule magnetostrictive effect. These ribbons are spot welded to the opposite sides of a magnetostrictive wire in order to produce torsional stress wave propagation in the wire in the manner of Scarrott and Naylor (Ref. 5). Three acoustic terminations are used to prevent reflection of the stress waves at the ends of the ribbons and of the wire. The stress waves which propagate along the magnetostrictive wire interact with magnetic fields established in the wire by external permanent magnets to induce voltages in the wire. The voltages from the interactions are superimposed by the wire and measured by the differential amplifier.

The voltage  $y(t)$  out of the amplifier may be interpreted as the convolution of the impulse response  $h(t)$  of the delay line with its input function  $x(t)$ .

$$y(t) = x(t) \star h(t)$$

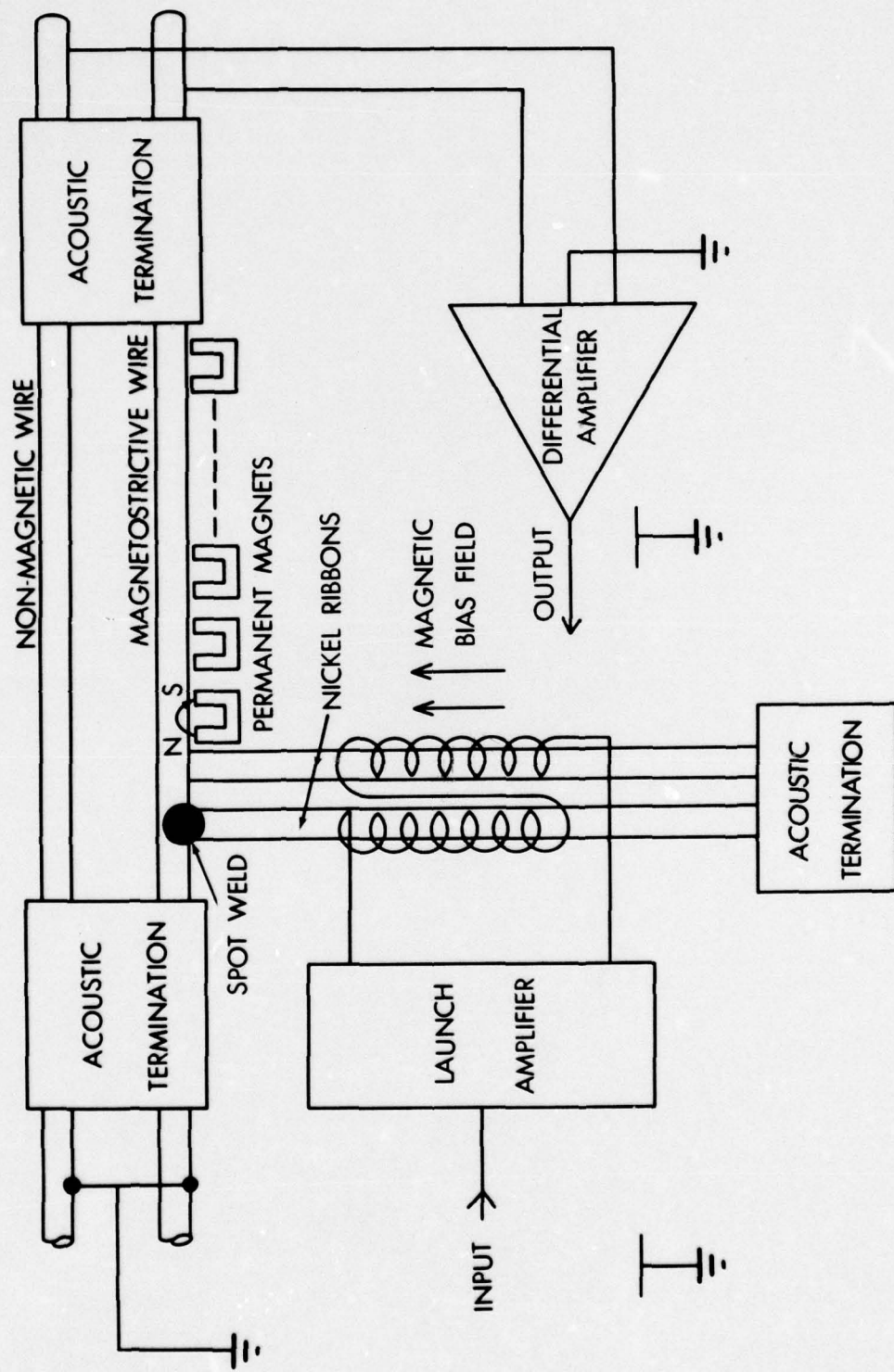

FIG. 1. General Features of the Torsional Delay-Line Matched Filter.

$$y(t) = \int_{t-T}^t x(\tau)h(t-\tau)d\tau$$

Let the input  $x(t)$  represent a known signal  $s(t)$  and a noise  $n(t)$

$$x(t) = s(t) + n(t)$$

where  $n(t)$  is a sample function for a wide-sense stationary process.

The output signal-to-noise ratio

$$\left(\frac{S}{N}\right)_o = \frac{S_o^2(t)}{E[n_o^2(t)]}$$

$$S_o = s(t) \star h(t)$$

$$N_o = n(t) \star h(t)$$

$E$  = expected value

is the quantity we wish to maximize at some  $t_1$ . Davenport and Root (Ref. 6) show that in the case of white noise, where  $N$  is the noise power

$$h(\tau) = \frac{1}{N} s(t_1 - \tau) \quad 0 \leq \tau \leq T$$

will maximize the output signal-to-noise ratio. Thus the filter which maximizes the output signal-to-noise ratio has an impulse response which is the signal run backwards from the fixed time  $t_1$ . Since the

impulse response of the delay line is essentially a two-level code of length 512 bits, with the code determined by magnet orientation and the sense of the input, this delay-line structure can be configured to act as a matched filter for any two level 512 bit-length code.

## CONSTRUCTION

The delay-line housing is constructed by using a digitally-controlled numerical mill to machine a succession of slots for magnet holders along a helical path around the outside of a 10-inch diameter hollow aluminum cylinder, as shown in Fig. 2 and 3. Determination of the spacing between slots is based on the operating frequency of the unit and the velocity of propagation of torsional shear waves in the magnetostrictive delay-line wire. The material between the slots is removed and a mechanical reference surface is formed in the bottom of the helical groove. A plastic ribbon is inserted in the helical groove. The ribbon has a raised portion once every five magnet slots in order to support the delay-line wire with as little mechanical damping as possible.

Two wires are wound over the plastic ribbon in the helical groove. The plastic ribbon electrically isolates them from the aluminum housing. One is a magnetostrictive torsional delay-line wire, the other is a non-magnetic wire. The magnetostrictive wire is wrapped over raised portions of the plastic ribbon; the nonmagnetic wire is not. Both wires pass through two acoustic termination blocks. One block, located at

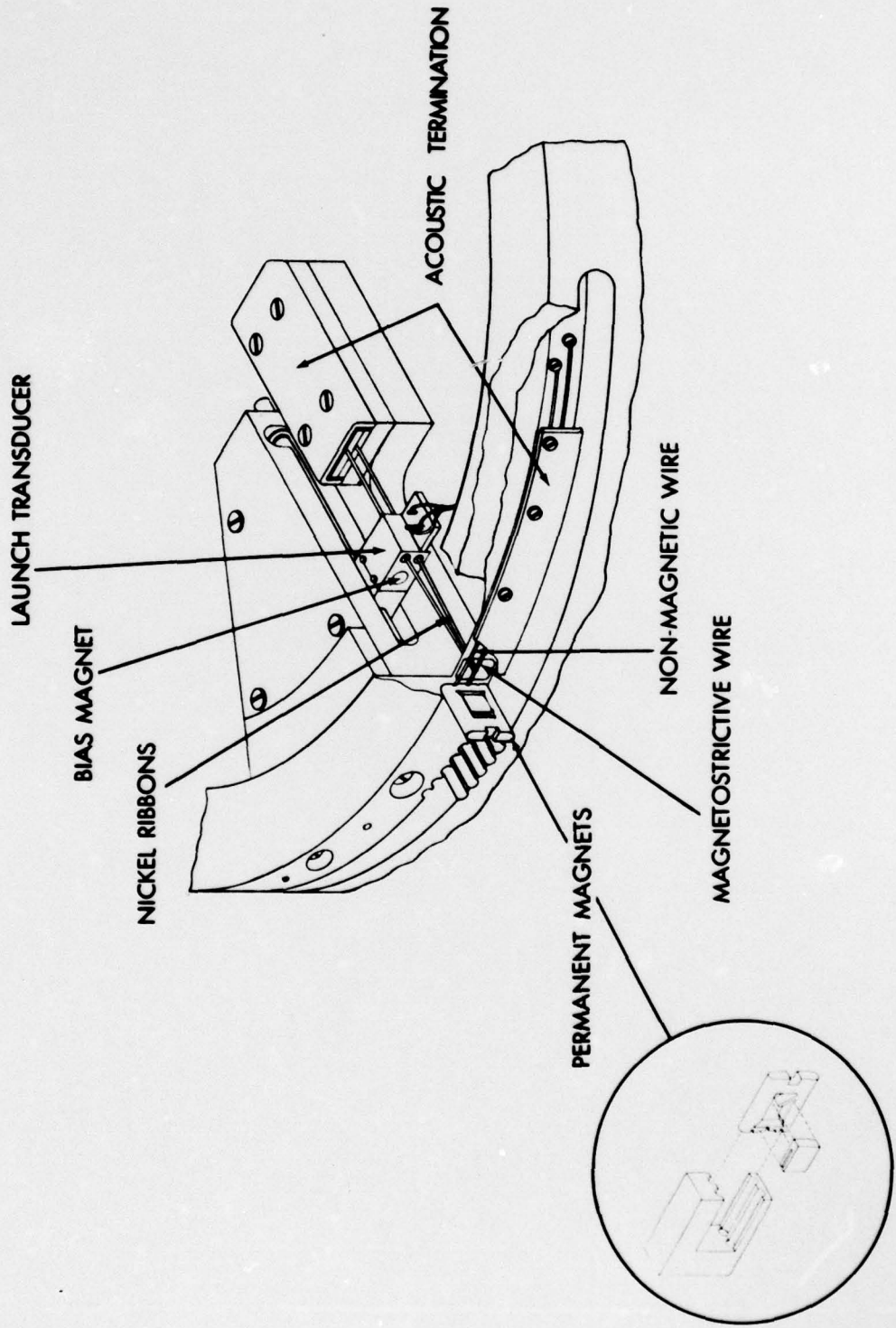

FIG. 2. Details of the Launch Structure, Magnet Holders, and Magnets.

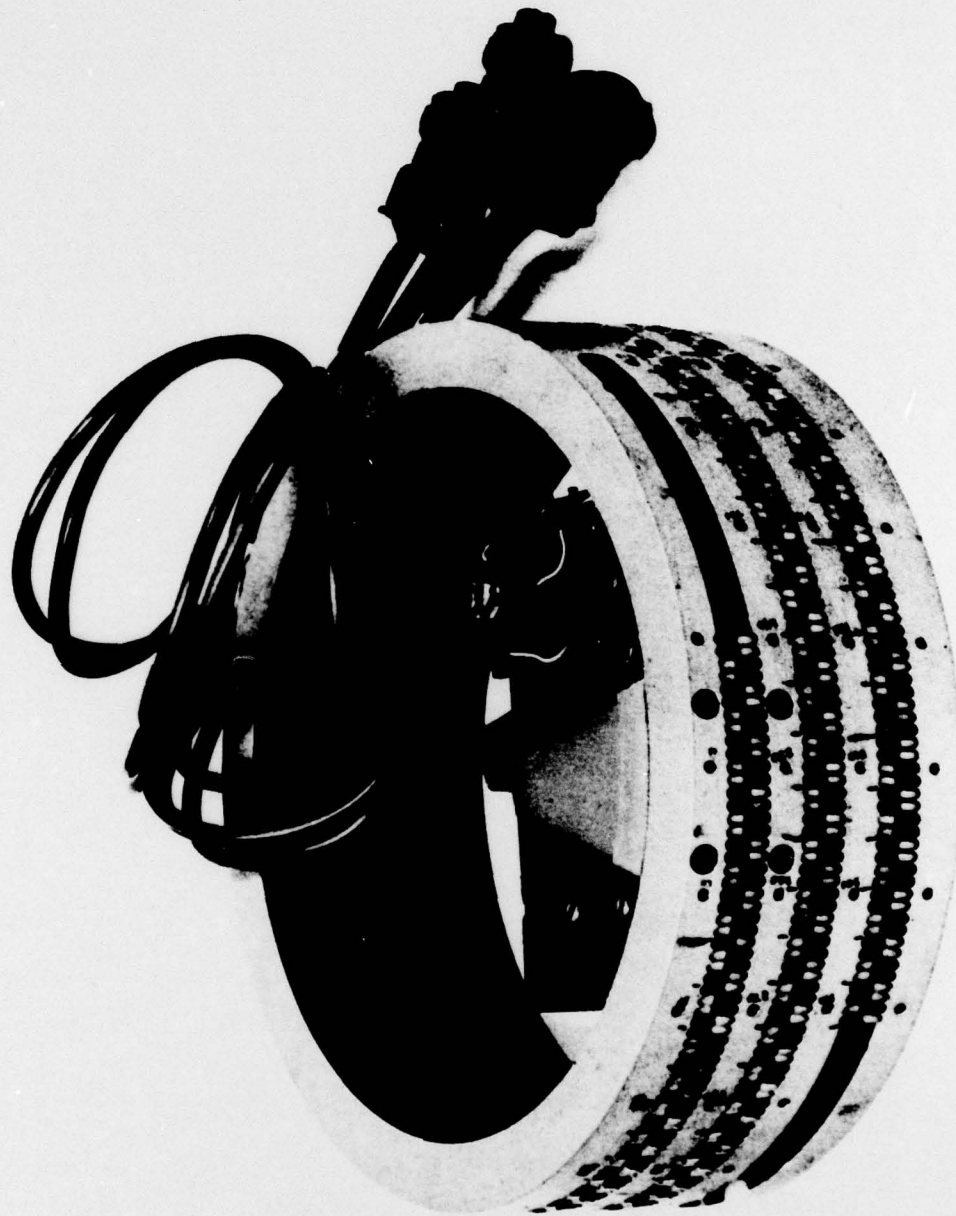

FIG. 3. The 1-Mc Torsional Delay-Line Matched Filter Unit.

the launch end, prevents reflection of the backward acoustic waves; and the other block, located at the terminal end, prevents reflections of the forward acoustic waves which have propagated along the delay-line wire. Both wires are grounded to the housing at the launch end and are connected to electrical feed-throughs, mounted in a nylon bushing, at the terminal end. A differential amplifier measures the voltage between the magnetostrictive and the nonmagnetic wires. The output of this amplifier is the voltage induced in the magnetostrictive wire by the interaction of the acoustic stress waves and the permanent magnets. Because of the differential connection, the output of the differential amplifier does not contain voltages caused by electrical pickup of the coiled wires.

A transducer mounting block is attached to the inner surface of the delay-line housing at the beginning of the magnet slots. The mounting block houses the launch transducer and the adjusting screw on which the launch transducer rides. The launch transducer was made by Ferranti Electric<sup>1</sup> and is mechanically equivalent to the Ferranti input transducer for their L30 delay line. However, this transducer is driven differentially from an 80-ma current source. Electrical specifications of the transducer are as follows:

---

<sup>1</sup>Ferranti Electric, Inc., Plainview, New York

center frequency:	1 Mc
bandwidth:	1 Mc
input impedance:	125 ohms at 1 Mc, center tapped.

The nickel ribbons pass through an aperture in the delay-line housing and through the launch transducer to an acoustic terminating block on the back of the transducer mount. This terminating block which is used to prevent reflection of the acoustic waves from the end of the ribbons is a modified terminating block for magnetostrictive delay lines manufactured commercially by Ferranti Electric. The Ferranti acoustic absorbing material and cover are mounted on a spacer plate which is mounted on the transducer mount at the end opposite the delay-line wire.

The voltage induced in the wire by a torsional pulse propagating past a permanent magnet is about 50 microvolts when the delay-line wire is nickel or Ni-Span C; therefore, it is necessary to have a pre-amplifier located in close proximity to the unit. A differential pre-amplifier is mounted in a shielded box in the center of the housing and is suspended from the transducer mount. The differential amplifier has inputs supplied by the delay line and the nonmagnetic wire as shown in Fig. 1.

Since the reference signal for the correlator is determined by the orientation of each of the magnets, the magnet holders have two auxiliary grooves to accept the nonmagnetic wire with either orientation

of the magnet holders. A groove in the top of the magnet holder takes O-ring stock and is used to hold the magnet holders against the reference surface when the cover is attached. Figure 3 is a photograph of the 1-Mc matched filter (without cover) to show construction details.

The magnets are fabricated from Alnico 5. The pole-to-pole dimensions are determined by the operating frequency of the delay line and the velocity of propagation of shear waves in the magnetostrictive material of the delay-line wire. In the unit shown, the dimensions are 0.113 inch. The magnets are magnetized across the gap to form small horseshoe magnets. The delay-line wire, which must be magnetostrictive<sup>2</sup>, is 0.020-inch diameter Ni-Span C 902 (42 Ni, 49 Fe, 9 other). Ni-Span C is used rather than pure nickel, which has a larger magnetostrictive effect, because Ni-Span C has a lower thermal coefficient of acoustic delay and lower acoustic attenuation. Ni-Span C is available from Techalloy Co.<sup>3</sup>

---

<sup>2</sup>The voltage induced in the delay line by a torsional pulse propagating past a magnet is due to the Wertheim effect. This effect depends on magnetostriction.

<sup>3</sup>Techalloy Co., Inc., Rahns, Pennsylvania

## SYSTEM DESIGN

Design of the matched filter system is illustrated by a block diagram, Fig. 4. The sampler and digital time compressor are the essential features which allow the torsional delay-line matched filter to be used in a system operating in real time (Ref. 2). The time compressor contains a 4096-bit recirculating delay-line memory which precesses the same number of bits as there are sample bits during an access time to the delay line. Consider the case in which the access time of the time compressor is equal to the time between samples of the real time input. If the delay line is shortened one bit and recirculated during the time between input samples, the contents of the line will have precessed one bit when the next sampling occurs. At sample time the new bit replaces the oldest bit in the line. In this manner a compressed version of a real time input is available at the clock rate of the time compressor, not the sampling rate of the input.

The bandwidth of the input determines the sampling rate of the time compressor. Black (Ref. 7) gives the minimum sample rate  $f_m$  for a bandpass signal as

$$f_m = 2B(1 + k/m)$$

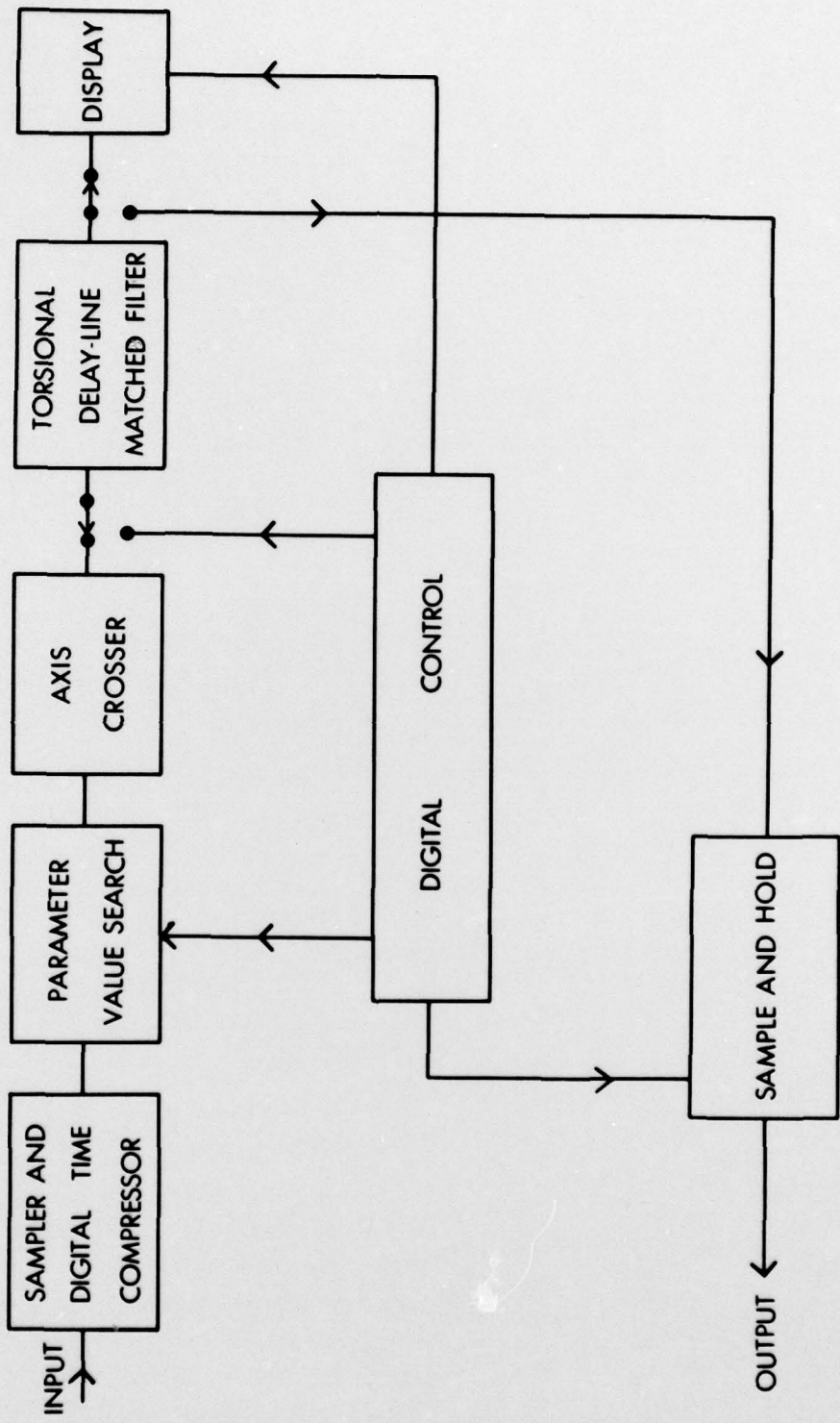

FIG. 4. Block Diagram of the Torsional Delay-Line Matched Filter System.

where

$B = f_h - f_l$  is the bandwidth to be sampled

$f_h$  = highest in-band frequency

$f_l$  = lowest in-band frequency

$k = f_h/B - m$

$m = (f_h/B)$  is the largest integer not exceeding  $f_h/B$ .

The compressed time signal available from the time compressor allows a search to be made for many discrete values of the signal's parameter. The output of the matched filter is continuous in time except for a transitional 512-bit interval which occurs each time the compressed signal containing a new search parameter is introduced into the matched filter. During this transitional 512-bit interval the output of the matched filter to the display is meaningless and is blanked.

If desired, the requirement for a blanking time during transition from one value of the signal parameter to another may be removed by using two magnetostrictive delay-line wires in the torsional delay-line matched filter instead of only one. Both wires would use the same magnet structure with the acoustic input to the second wire being the acoustic output of the first. This allows the time compressor to be constructed from a 1024-bit length delay line (only twice as long as the wire in the matched filter). Since the transition from one value to another of the signal's parameter could never occur simultaneously in

both wires in the matched filter, the differential amplifier may be programmed to switch automatically from one wire to the other depending upon which wire is then giving valid information.

The axis crosser normalizes the power into the matched filter so that the drive circuitry for the launch amplifier may operate between fixed levels, and so that the output for display will have a fixed dynamic range. This dynamic range is determined by the output of the matched filter when the matching signal alone is used for input.

## CODING

In order to use the torsional delay-line matched filter effectively, a code with suitable system properties must be selected. The properties of a code for a radar system are discussed in Woodward (Ref. 8) who introduces the concept of ambiguity to discuss the range and doppler properties of the post-detection response of various methods of coding. Klauder (Ref. 9) introduces the class of Hermite polynomial codes in order to find a code which is symmetric about the origin in range-doppler space. The Hermite polynomial codes have the property that the contours of constant ambiguity are ellipses about the origin. The magnitude of the major and minor axes of the ellipses may be selected arbitrarily.

In order to find a binary code with prescribed resolution in both range and range rate suitable for the device here presented, it was found possible to two-level quantize the appropriate Hermite polynomial code and terminate the exponential tail to match the 512 bit-length of the torsional delay-line matched filter. These modified codes preserve many of the desirable features of the Hermite polynomial codes and are conveniently encoded on the filter. To encode the filter, the two possible

orientations of the magnets are assigned to the two levels of the modified code, and the code is divided into as many subdivisions as there are magnets in the filter.

If the delay line is utilized to generate the signal to be detected, errors in the position of the magnets, such as may be caused by the temperature variations of delay or the accidental inversion of a magnet, are not critical. Such a signal can be generated in real time (Fig. 4) by successively impulsing the delay line so that samples taken in real time are the impulse response of the filter, backwards in time. The successive samples are stretched to real time by the hold circuit.

## PERFORMANCE

The torsional delay-line matched filter has been operated in the laboratory and its performance has been checked with the predicted performance for the code used. The code selected was a sequence of random numbers from a table of random digits (Ref. 10). The magnets were coded in polarity according to whether the digit read from the table was odd or even.

The impulse response of the torsional delay-line matched filter is found to be tapered in amplitude due to attenuation along the delay line wire. The ratio of amplitudes of the envelope of the impulse response at the start and finish is 2/1. Measurements indicate that this attenuation is a mechanical phenomenon caused by the wire support structure and is dependent on the fabrication technique.

The observed processing gain using the random code in band-limited Gaussian noise was greater than 25 db. The predicted processing gain for the tapered impulse response was 26 db while the predicted processing gain for a uniform impulse response would have been 27 db. Figure 5 is a photograph showing the impulse response of the matched filter for the random code. Figure 6 is a graph of the ambiguity function for this random code.

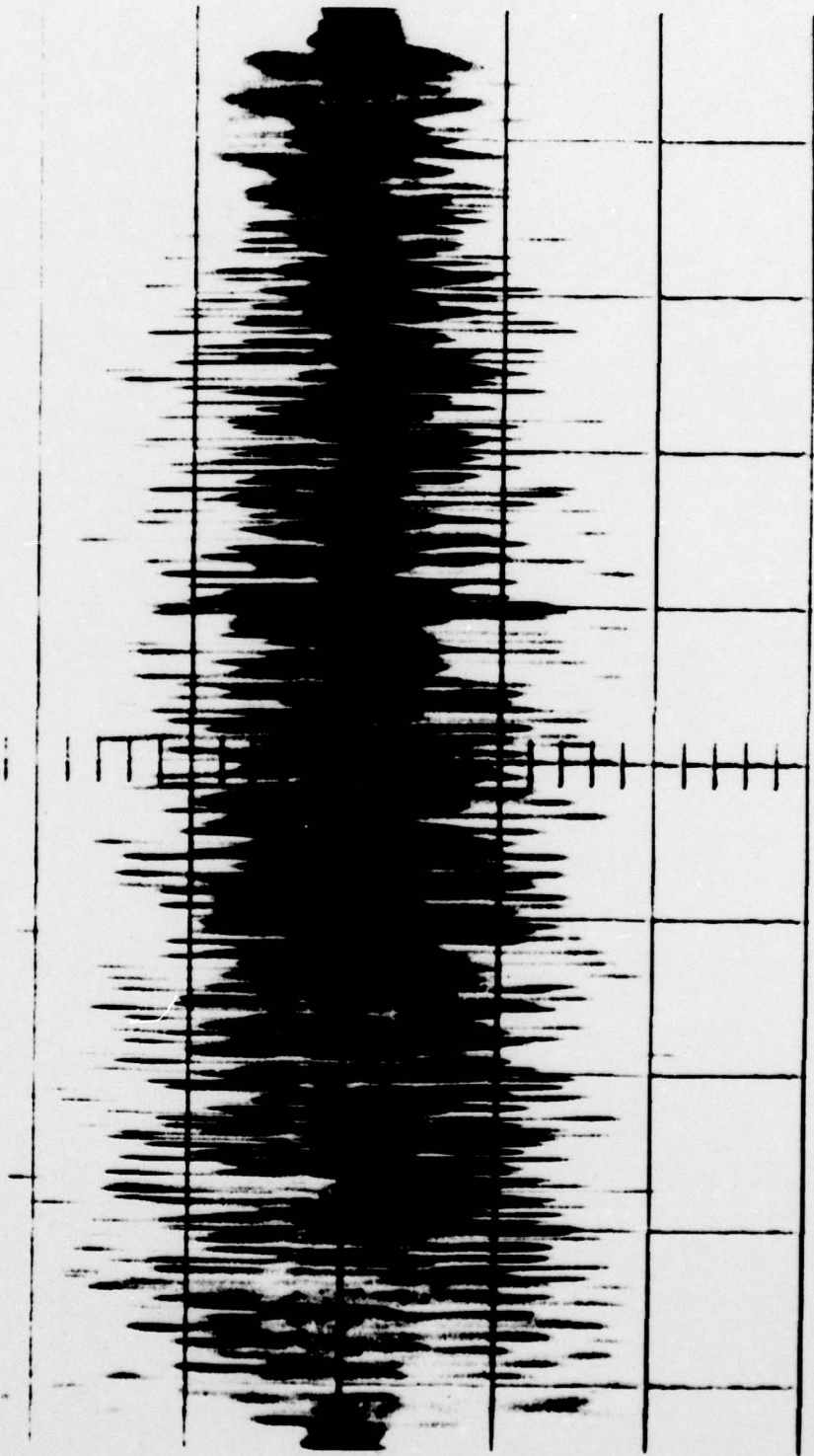

FIG. 5. Impulse Response of the Matched Filter with the 512 -Bit Random Code.

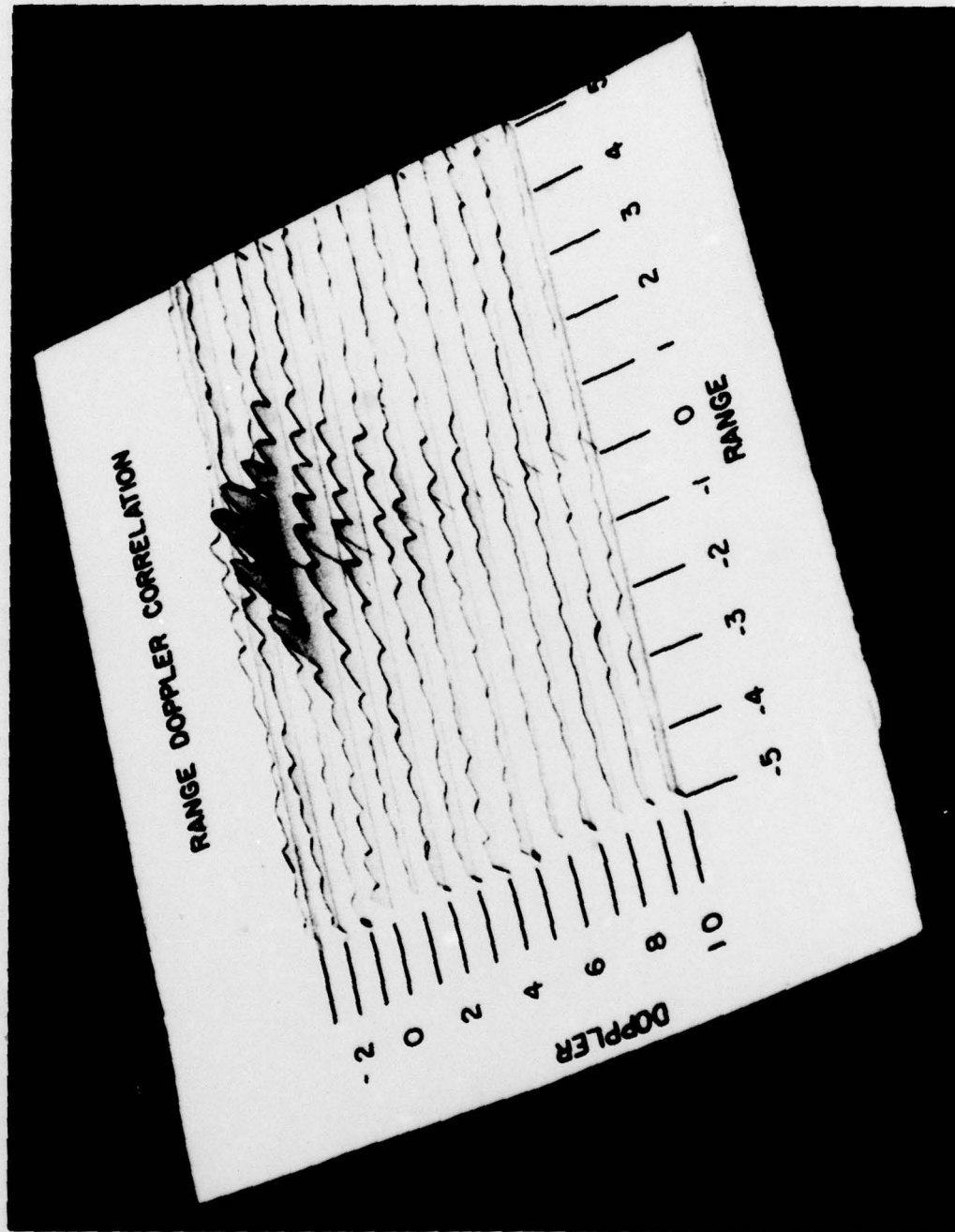

FIG. 6. Range Doppler Correlation Ambiguity Graph of the 512-Bit Random Code.

## BIBLIOGRAPHY

1. Siebert, W. McC., "A Radar Detection Philosophy," IRE Trans., IT-2, Sept. 1956.
2. Anderson, V. C., "The DELTIC Correlator," Harvard University, Acoustics Research Lab., Tech. Memo. 37, Jan. 1956.
3. Perzley, W. and Fishbein, M., "Digital Function Generation With Torsional Delay Lines," Electronics, Vol. 35, Jan. 1962.
4. Whitehouse, H. J., "Parallel Digital Delay-Line Correlator," Proc. IEEE, Vol. 51, Jan. 1963.
5. Scarrott, G. G. and Naylor, R., "Wire-Type Acoustic Delay Lines for Digital Storage," Proc., IEE, Vol. 103, pt B, Suppl. No. 3, March 1956.
6. Davenport and Root, "Random Signals and Noise," New York, McGraw-Hill, 1958. P. 244.
7. Black, H. S., "Modulation Theory," Princeton, New Jersey, Van Nostrand, 1953. Pp. 56, 57.
8. Woodward, P. M., "Probability and Information Theory, With Applications to Radar," New York, McGraw-Hill, 1953. Pp. 115-125.
9. Klauder, J. R., "The Design of Radar Signals Having Both High Range Resolution and High Velocity Resolution," BSTJ, Vol. 39, July 1960.
10. The Rand Corp., "A Million Random Digits With 100,000 Normal Deviates," Glencoe, Illinois, The Free Press, 1955. P. 369.