

AD-A074 476

ROME AIR DEVELOPMENT CENTER GRIFFISS AFB NY  
TWO-POLE VARACTOR-TUNED HELICAL RESONATOR FILTERS. (U)  
JUN 79 M R STIGLITZ  
RADC-TR-79-182

F/G 9/5

UNCLASSIFIED

NL

| OF |

AD  
A074476

1



END  
DATE  
FILMED  
10-79  
DDC

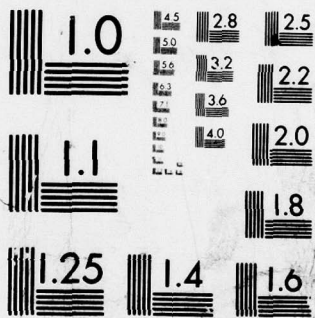

MICROCOPY RESOLUTION TEST CHART  
NATIONAL BUREAU OF STANDARDS-1963-A

17 LEVEL II



AD A 074476

14

RADC-TR-79-182

In-House Report

June 1979

12 21 p.

9 Rept. for Jan 77 - Mar 79

TWO - POLE VARACTOR-TUNED HELICAL RESONATOR FILTERS

10 Martin R. Stiglitz

16 4600

17 14

APPROVED FOR PUBLIC RELEASE; DISTRIBUTION UNLIMITED

DDC FILE COPY

DDC RECEIVED OCT 1 1979 B

ROME AIR DEVELOPMENT CENTER Air Force Systems Command Griffiss Air Force Base, New York 13441

309 050 79 10 01 080 B

This report has been reviewed by the RADC Information Office (OI) and is releasable to the National Technical Information Service (NTIS). At NTIS it will be releasable to the general public, including foreign nations.

RADC-TR-79-182 has been reviewed and is approved for publication.

APPROVED: *Walter Rotman*

WALTER ROTMAN, Chief  
Antennas and RF Components Branch  
Electromagnetic Sciences Division

APPROVED: *William R. Baschnager*  
WILLIAM R. BASCHNAGER, Lt Colonel, USAF  
Assistant Chief  
Electromagnetic Sciences Division

FOR THE COMMANDER:

*John P. Huss*  
JOHN P. HUSS  
Acting Chief, Plans Office

If your address has changed or if you wish to be removed from the RADC mailing list, or if the addressee is no longer employed by your organization, please notify RADC (EEA) Hanacom AFB MA 01731. This will assist us in maintaining a current mailing list.

Do not return this copy. Retain or destroy.



**MISSION**  
*of*  
**Rome Air Development Center**

*RADC plans and executes research, development, test and selected acquisition programs in support of Command, Control Communications and Intelligence (C<sup>3</sup>I) activities. Technical and engineering support within areas of technical competence is provided to ESD Program Offices (POs) and other ESD elements. The principal technical mission areas are communications, electromagnetic guidance and control, surveillance of ground and aerospace objects, intelligence data collection and handling, information system technology, ionospheric propagation, solid state sciences, microwave physics and electronic reliability, maintainability and compatibility.*

Printed by  
United States Air Force  
Hanscom AFB, Mass. 01731

Unclassified

SECURITY CLASSIFICATION OF THIS PAGE (When Data Entered)

REPORT DOCUMENTATION PAGE		READ INSTRUCTIONS BEFORE COMPLETING FORM
1. REPORT NUMBER RADC-TR-79-182	2. GOVT ACCESSION NO.	3. RECIPIENT'S CATALOG NUMBER
4. TITLE (and Subtitle) TWO-POLE VARACTOR-TUNED HELICAL RESONATOR FILTERS	5. TYPE OF REPORT & PERIOD COVERED In-House Report Jan 77 - Mar 79	
	6. PERFORMING ORG. REPORT NUMBER	
7. AUTHOR(s) Martin R. Stiglitz	8. CONTRACT OR GRANT NUMBER(s)	
9. PERFORMING ORGANIZATION NAME AND ADDRESS Deputy for Electronic Technology (RADC/EEA) Hanscom AFB Massachusetts 01731	10. PROGRAM ELEMENT, PROJECT, TASK AREA & WORK UNIT NUMBERS 46001404	
11. CONTROLLING OFFICE NAME AND ADDRESS Deputy for Electronic Technology (RADC/EEA) Hanscom AFB Massachusetts 01731	12. REPORT DATE June 1979	
	13. NUMBER OF PAGES 19	
14. MONITORING AGENCY NAME & ADDRESS (if different from Controlling Office)	15. SECURITY CLASS. (of this report) Unclassified	
	15a. DECLASSIFICATION/DOWNGRADING SCHEDULE	
16. DISTRIBUTION STATEMENT (of this Report)  Approved for public release; distribution unlimited.		
17. DISTRIBUTION STATEMENT (of the abstract entered in Block 20, if different from Report)		
18. SUPPLEMENTARY NOTES		
19. KEY WORDS (Continue on reverse side if necessary and identify by block number) Tunable filters Varactor-tuned filters Tunable UHF		
20. ABSTRACT (Continue on reverse side if necessary and identify by block number) Two-pole varactor-tuned helical resonator filters that operate in the 960 to 1215 MHz band have been designed and built. They exhibit group delays of less than 10 nsec, and can be constructed to have insertion losses of 3 dB or less. Two designs have been investigated, one where both sections of the filter were tuned with a single bias source, and the other where each section was tuned individually. Varactor diodes are sensitive to changes in input power level and they are saturated at rf power levels above 0.3 mW. Tuning speeds of 10 $\mu$ sec are		

DD FORM 1473 1 JAN 73 EDITION OF 1 NOV 65 IS OBSOLETE

Unclassified  
SECURITY CLASSIFICATION OF THIS PAGE (When Data Entered)

micro

Unclassified

SECURITY CLASSIFICATION OF THIS PAGE(When Data Entered)

20. (Cont)

possible when care is taken to minimize the inductances in the bias circuits.

ACCESSION for	
NTIS	White Section <input checked="" type="checkbox"/>
DDC	Buff Section <input type="checkbox"/>
UNANNOUNCED	<input type="checkbox"/>
JUSIFICATION	_____
BY _____	
DISTRIBUTION/AVAILABILITY CODES	
Dist. <input type="checkbox"/> ALL and/or SPECIAL	
A	

Unclassified

SECURITY CLASSIFICATION OF THIS PAGE(When Data Entered)

## Contents

1. INTRODUCTION	5
2. CRITERIA, REQUIREMENTS, AND TRADE-OFFS	6
3. VARACTOR TUNING OF THE HELICAL RESONATOR	7
4. EXPERIMENTS WHERE BOTH RESONATORS OF A TWO-POLE FILTER WERE TUNED WITH A SINGLE CONTROL VOLTAGE	8
5. TWO-POLE FILTER WITH INDEPENDENTLY TUNED FILTER SECTION	11
5.1 Filter Design	11
5.2 Experimental Results	13
6. CONCLUSION	15
APPENDIX A: Helical Resonator Design Method	17

## Illustrations

1. Diode Capacitance as a Function of Bias Voltage of Two MA46600J Varactors	7
2. Circuit Diagram of Varactor-Tuned Helical Resonator Filter	8
3. Passband Frequency of a Two-Pole Resonator Tuned by a Single Control Voltage	9
4. Frequency Responses of a Varactor-Tuned Helical Resonator Filter, Where Both Sections are Tuned by a Single Control Voltage	10

## Illustrations

5.	Parts of Two-Pole Varactor-Tuned Helical Resonator Filter	10
6.	Circuit Diagram of Two-Pole Varactor-Tuned Helical Resonator Filter With Individually Controlled Bias Voltages	11
7.	Blow-up View of Two-Pole Helical Resonator Filter Designed for Individually Controlled Bias Voltages	12
8.	Output Power Variation Over the Tuning Range From 1000 to 1240 MHz	13
9.	Possible Temperature Compensation for Diode Drift With Two Diodes in Push-Pull Hookup	14
10.	Output Power as a Function of Input Power; Strongly Coupled Input and Weakly Coupled Output	14
A1.	Diagram for Finding Unloaded Q in Helical Resonator	17
A2.	Design Chart for Quarter-Wave Helical Resonators	19

## Tables

1.	Experimental Results	15
----	----------------------	----

## Two-Pole Varactor-Tuned Helical Resonator Filter

### 1. INTRODUCTION

An Air Force requirement for a wide band tunable rf filter for airborne and spaceborne terminals<sup>1</sup> in two frequency ranges (225-400 MHz and 960-1215 MHz) resulted in two approaches for solving the problem. The first effort on the 225 to 400 MHz filters, which also touched on the higher frequency requirement, was completed in May 1976 and was reported on by Lammers and Stiglitz.<sup>2</sup> The emphasis of their study was on low insertion loss and on full coverage of the required frequency range.

Subsequent modifications of the original TN shifted the emphasis to the higher communications band (960-1215 MHz), and an additional restriction was imposed: that the maximum change in group delay should not exceed 10 nsec. Calculations of the circuit parameters showed that a single-pole filter could not satisfy the group delay requirements, and a two-pole filter geometry would have to be employed.

Lammers and Stiglitz<sup>2</sup> discussed in detail single-pole filters in the frequency ranges of from 225 to 400 MHz, as well as one filter that operated from 960 to

---

(Received for publication 19 June 1979)

1. TN ESD/AFAL/RADC/AFCL 1407-72-02 Rev., Dec. 1975.
2. Lammers, U. H., and Stiglitz, M. R. (1976) Varactor-Tuned Helical Resonators at UHF, RADC-TR-76-138, Rome Air Development Command, AFSC, Griffis AFB, New York, 13441.

to 1130 MHz. The entire range was covered by four tunable resonators with helical inner conductors of various pitch, keeping the outer shield dimensions constant.

The circuit theory, dealing with the relationships between filter bandwidth, insertion loss, circuit Q, and tuning range, was fully developed in the earlier report<sup>2</sup> and will not be repeated here.

The helical resonator filters were designed by referring to the work of Macalpine and Schildknecht.<sup>3</sup> For convenience, a brief design summary is presented in Appendix A. When designing a varactor-tuned helical resonator cavity, the de-tuning effect of the resonator due to inductive loading must be taken into account when the varactor is inserted into the unloaded cavity. Experimentation revealed that the resonance frequency of the unloaded cavity dropped approximately 17 percent when the varactor diode was inserted.

## 2. CRITERIA, REQUIREMENTS, AND TRADE-OFFS

The program for which the resonators was designed called for the following general filter specifications:

- Tuning ranges:
  - 969 to 1008 MHz
  - 1053 to 1065 MHz
  - 1113 to 1206 MHz.
- Maximum insertion loss (including pre-amplifier, if needed) 1 dB.
- Degradation of receiver noise figure with filter installed should not exceed 1 dB over tuning range.
- Frequency response—maximum variation over tuning range: 1 dB (goal).
- Tuning time: 3  $\mu$ sec or less.
- Bandwidth: 3 dB bandwidth shall not exceed 10 MHz.
- Maximum variation in group delay within 5 MHz of center frequency shall not exceed 10 nsec (goal).

It became apparent that not all parameters in the above list could be achieved simultaneously at their optimum values and that some trade-offs had to be allowed. Through the use of the two-pole filter it was possible to meet the group delay criteria. This gain was achieved at the cost of higher insertion losses than specified. The minimum insertion losses we were able to achieve were approximately 3 dB. This figure included coupling losses and losses introduced by the varactor diodes. The computed group delay distortion within the 3 dB pass band of a

---

3. Macalpine, W. W., and Schildknecht, R.O. (1959) Coaxial resonators with helical inner conductor, Proc. of the IRI, 47(No. 12):2099-2105.

double-pole, maximally flat, time delay filter was 8.3 nsec, which is within the 10 nsec specification.

The minimum insertion loss was reached by tightening the coupling between the input and output terminals and their respective helical resonators and the coupling between resonators.

### 3. VARACTOR TUNING OF THE HELICAL RESONATOR

A varactor diode is characterized by the mechanism that the diode's inherent capacitance can be controlled to some degree by varying its bias voltage. As the negative voltage across the diode increases, its capacitance decreases. A plot of the capacitance as a function of bias voltage is shown in Figure 1 for two nearly matched MA466004 gallium arsenide (GaAs) Schottky barrier varactor diodes.

These are abrupt junction diodes, especially selected for maximum Q and low losses at microwave frequencies. These diodes are used as variable capacitors in the resonant circuit formed by the helical inner conductor and the shield of the helical resonator structure.

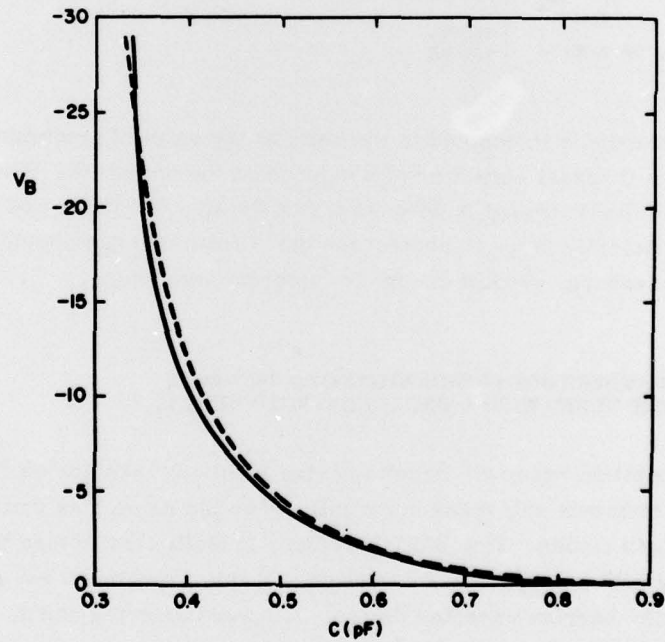

Figure 1. Diode Capacitance as a Function of Bias Voltage of Two MA46600J Varactors

A resonant circuit consists of capacitive and inductive reactive elements. If the tank circuit is designed with a very low capacitance and the varactor diode is coupled to that circuit, its changing capacitance will control the resonance frequency over a wide range. A circuit diagram depicting a varactor-tuned helical resonator is shown in Figure 2. The diagram shows a single-pole half-wave filter, where both ends of the helical inner conductor are grounded to the outer shield.

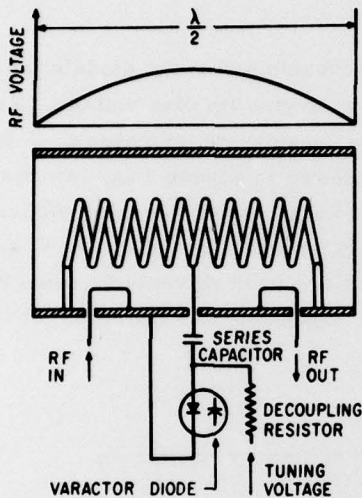

Figure 2. Circuit Diagram of Varactor-Tuned Helical Resonator Filter

The varactor diode is coupled to the helix at the point of maximum rf voltage through a series (bypass) capacitor of a nominal value of 100 pF. The bias voltage is applied to the diode through a de-coupling resistor. Its value was chosen as 1 megohm, sufficiently large to protect the diode from damage should the bias leads be accidentally reversed, yet low enough to allow for fast tuning.

#### 4. EXPERIMENTS WHERE BOTH RESONATORS OF A TWO-POLE FILTER WERE TUNED WITH A SINGLE CONTROL VOLTAGE

Ideally, identical resonant circuits having identical varactor diodes as part of their reactive elements will track coherently when the same bias voltage is impressed upon both diodes. It would, therefore, be sufficient to tune both cavities simultaneously with a single control voltage. In this experiment we used two gallium arsenide Schottky barrier varactor diodes\* that were selected and as closely matched as was possible from the limited quantity of high Q varactors available.

\* Manufactured by Microwave Associates of Burlington, MA; selected and purchased on special order for this project.

The helical inner conductors of the two cavities, with their respective varactor diodes in place, were trimmed in such a fashion that the output responses were congruent around the midpoint of the tuning range (around 1100 MHz). Figure 3 depicts the resultant filter response. The amplitude of the output signal varied by approximately 3 dB over the tuning range from 960 to 1240 MHz. The 3 dB bandwidth was 18 MHz, as can be seen on the oscillograms, Figure 4. Even though the difference in capacitance of the two diodes was small at a particular applied bias voltage, its effect on the tuning curves was sufficiently large to contribute to the broadening of the total filter bandwidth. Placing the two diodes into their individual cavities, coupled to each other as shown in Figure 5, resulted in the curve shown in Figure 3 that depicts the relationship between the control voltage  $V_B$  and the pass-band frequency of a two-pole filter tuned by a single common control voltage.

Note that the filter tuned well over the entire TACAN band (960-1215 MHz). The actual tuning range was from 942 to 1300 MHz or 32 percent of the midrange.

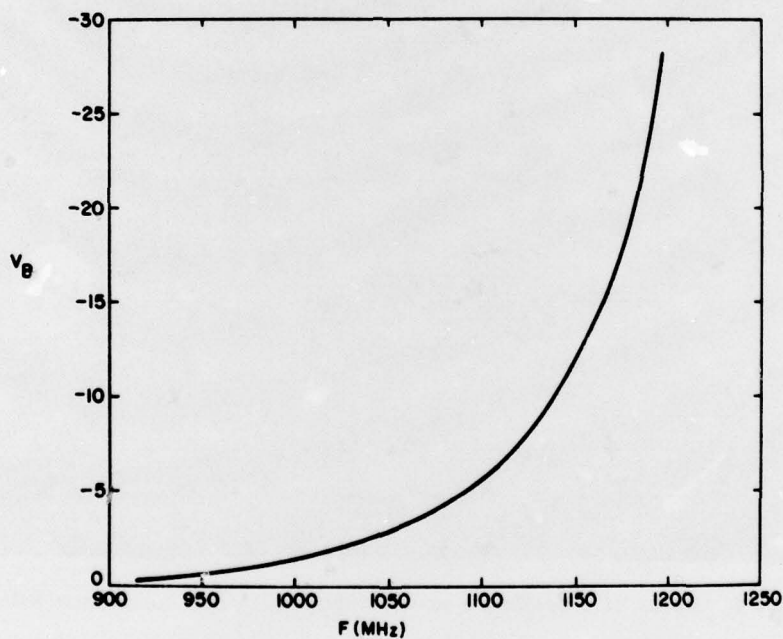

Figure 3. Passband Frequency of a Two-Pole Resonator Tuned by a Single Control Voltage

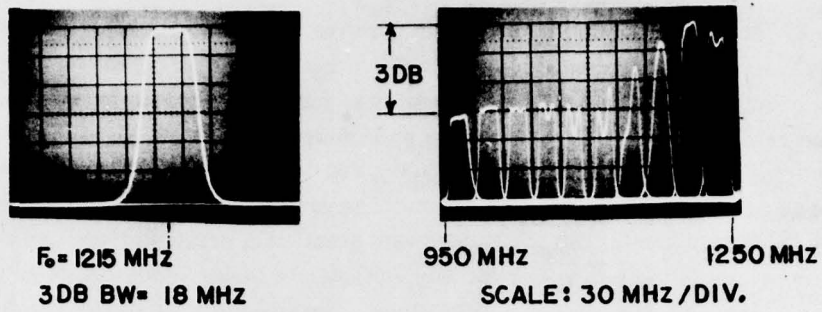

Figure 4. Frequency Responses of a Varactor-Tuned Helical Resonator Filter, Where Both Sections are Tuned by a Single Control Voltage

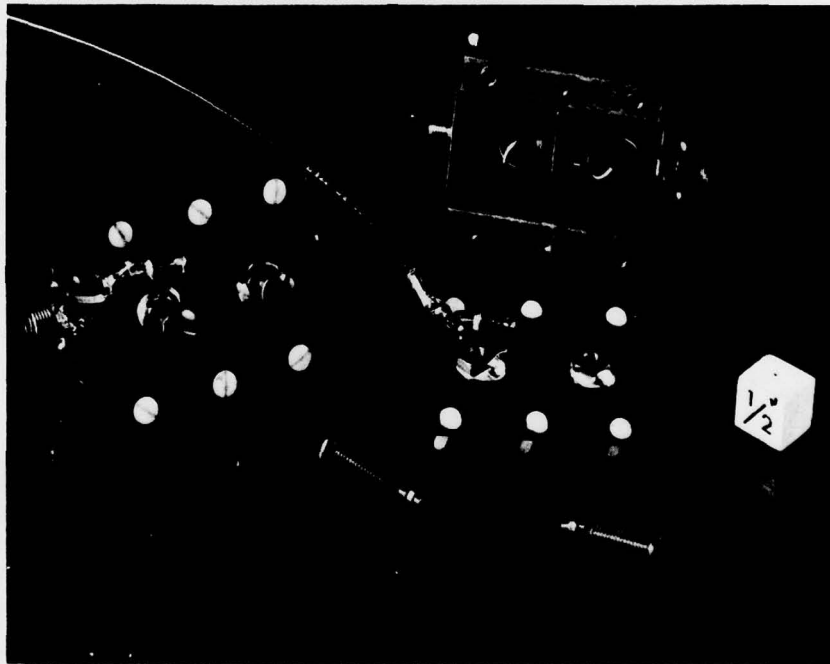

Figure 5. Parts of Two-Pole Varactor-Tuned Helical Resonator Filter

The control voltage was varied between 0.1 V and 29 V (negative) to tune over the entire frequency band. Tuning sensitivity of varactors is greatest at low voltage values. Fifty percent of the tuning range was covered with bias voltage from -0.1 V to -5 V, while the second half of the tuning range required an additional 27 V.

A single filter had a bandwidth of 10 MHz or less; however, the combined bandwidth of the two-pole filter was 18 MHz due to tracking errors, as seen on the oscillographs. For this reason a new two-pole version of the helical resonator filter was designed that allowed both filter sections to be tuned independently to compensate for differences in the varactor characteristics, as well as for coupling imbalances.

## 5. TWO-POLE FILTER WITH INDEPENDENTLY TUNED FILTER SECTION

### 5.1 Filter Design

The filter is shown in Figure 6 and Figure 7 (exploded view). In Figure 6 we see two identical helical coils,  $H_1$  and  $H_2$ , seated in their individual cavities and coupled with each other by means of rf loop antennas  $L_1$  and  $L_2$ . The input and output rf signals are coupled to the helical resonators by means of loop antennas  $L_3$  and  $L_4$ , respectively. Bias voltage control to diodes  $VD_1$  and  $VD_2$  is supplied through de-coupling resistors  $R_1$  and  $R_2$ . Series capacitors  $C_1$  and  $C_2$  block the dc control voltage from shorting to the housing.

Coupling to the external circuitry may be adjusted by varying the length and position of coupling loops  $L_3$  and  $L_4$ , while coupling loops  $L_1$  and  $L_2$  control the coupling between the two cavities. The graph to the right of the circuit diagram depicts the rf voltage across the helix. Since the helical inner conductor is grounded at the housing, the rf voltage at the grounded end of the coil is zero. The maximum voltage is at the 1.4 wavelength point, which corresponds to the upper end of the helix where the varactor diode is mounted.

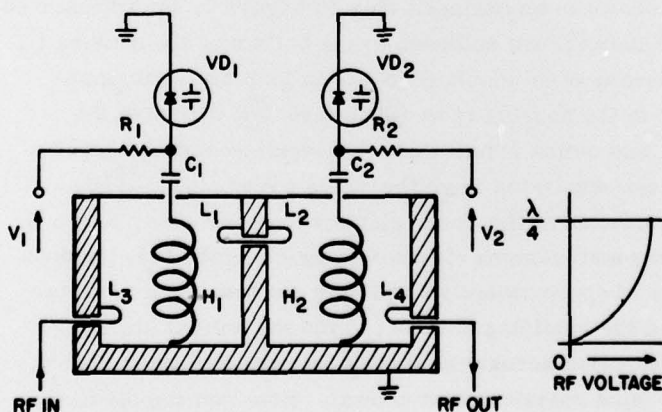

Figure 6. Circuit Diagram of Two-Pole Varactor-Tuned Helical Resonator Filter With Individually Controlled Bias Voltages

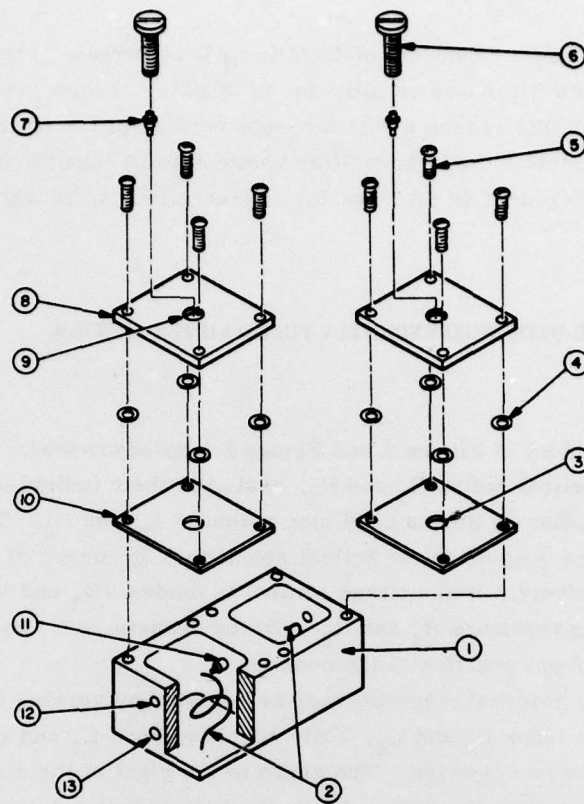

Figure 7. Blow-up View of Two-Pole Helical Resonator Filter Designed for Individually Controlled Bias Voltages

The actual assembly, as shown in an exploded view in Figure 7, is dimensioned  $1\text{-}1/4 \times 1\text{-}1/2 \times 3$  in. The helices (2) are soldered to the bottom of the housing (1) and coupled to each other by means of an insulated coupling loop or coupling antenna (11). The coaxial input to the housing is at (13) where (12) indicates the ground connection. The input and output connections are identical and at opposite sides. The cover plates (10) are separated from the upper cover plates (8) by Teflon spacers (4). The combination of the cover plates and upper cover plates, separated by the Teflon spacers and clamped together by nylon screw (5), produce the series (input) capacitances of approximately 50 pF per section. The varactor diodes (7) are secured between the retaining screws (6) and the helical inner conductors (2). Bias voltage is supplied across the diodes between the upper covers and the filter housing through input resistors (not shown). Note that the diode retaining screws are engaged in the threaded upper cover holes (9) and pass through

the cover plate clearing holes (3). The upper cover plate is "hot", since it is raised to the bias voltage with respect to the grounded housing. Since the input (series) capacitance is produced essentially by a high Q air capacitance, capacitive losses are held to a minimum and resonator Q is minimally degraded.

## 5.2 Experimental Results

In this experiment the input circuit was tightly coupled; however, the output circuit was loosely coupled to the second helical resonator cavity. The input and output loops were constructed of 0.0170-in.-diam silver-plated copper wire. The wire of the helical coil was 0.050-in. diam. The helical inner conductor had a mean diameter of 0.5 in. and was approximately 1 turn long at 3/4 in. pitch. The coil was wound somewhat longer than the required length, and was trimmed in small increments to produce the required resonance frequency when the maximum bias voltage was impressed on the varactor diode.

The output power as a function of input frequency of a narrow-band signal tuned over a 200 MHz band is shown in Figure 8. The output signal level was within 3 dB except for a 20-MHz-wide band at 1.125 GHz, where the variation in output power was 6 dB (max). Varactor diodes are very sensitive to input power variation and saturate nominally at powers of 0.25 mW. The effect of capacitance changes due to changes in input rf voltage can be compensated for by operating two similar diodes back-to-back in the push-pull configuration shown in Figure 9.

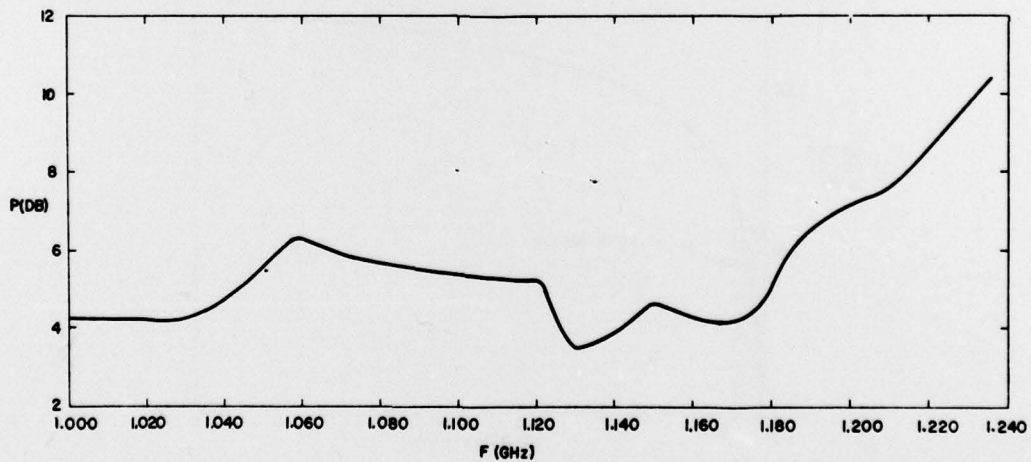

Figure 8. Output Power Variation Over the Tuning Range From 1000 to 1240 MHz

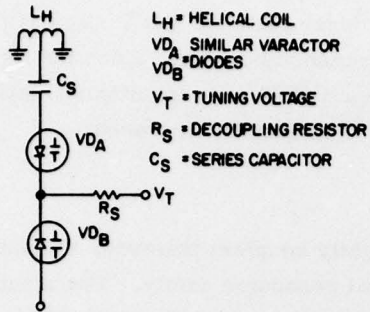

Figure 9. Possible Temperature Compensation for Diode Drift With Two Diodes in Push-Pull Hookup

In this manner the rf voltage swing will tend to increase the capacitance of, say, varactor  $VD_A$ , while it decreases the capacitance of  $VD_B$ , hence providing a nearly constant average value of capacitance. The saturation effect, however, can not be overcome that easily, and it is necessary to operate varactor-tuned devices at low input power levels, nominally below 0.2 mW.

A typical curve of input power vs output power, where the output circuit was weakly coupled, is shown in Figure 10. It can be seen that the relation between input and output power is linear up to inputs of 0.3 mW, and it reaches near saturation at input power above 1.5 mW.

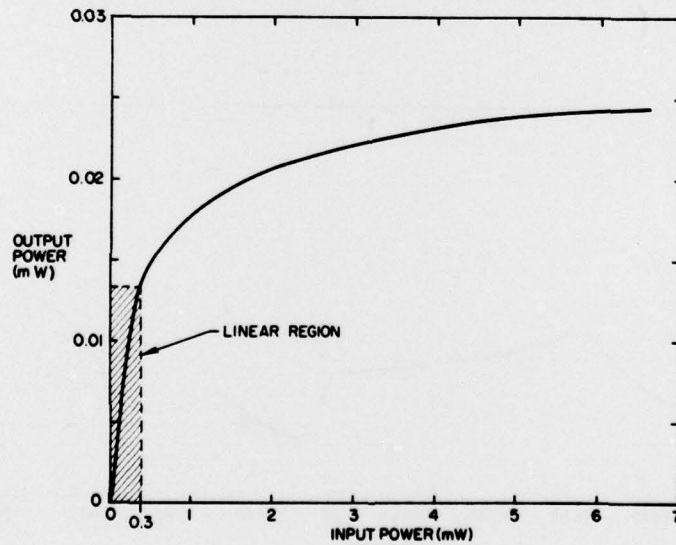

Figure 10. Output Power as a Function of Input Power; Strongly Coupled Input and Weakly Coupled Output

In most of the above experiments we used GaAs as tuning varactors. They are abrupt junction devices that feature very high Q and large capacitance tuning ratios. Other desirable diode characteristics are low leakage, close capacitance tracking, and minimum post-tuning drift. At microwave frequencies the abrupt junction devices offer the best compromise between switching speed and Q. High Q is most important for microwave applications. The Q of the hyper-abrupt devices is an order of magnitude lower than that of tuning diodes with abrupt junctions, ruling hyper-abrupt junction diodes out at these frequencies.

## 6. CONCLUSION

We have shown that helical resonators at microwave frequencies can be tuned with high Q varactor diodes over a large frequency band and that some of the requirements can be met with a single two-pole filter, while other requirements will have to be relaxed if these filters are to be used for the TN application. Table 1 presents the requirements on the left and the accomplishments on the right.

Table 1. Experimental Results

	Required	Achieved
Tuning Range	969-1206 MHz	950-1240 MHz
Maximum Insertion Loss	1 dB	3 dB
Frequency Response (maximum variation over tuning range)	1 dB	3 dB
Tuning Time	3 $\mu$ sec max	3 $\mu$ sec
Bandwidth	10 MHz	18 MHz (10 MHz with individually tuned Filter Sections)
Maximum Variation in Group Delay	10 nsec	8 nsec

One of the characteristics of varactor-tuned resonators is their sensitivity to overloading at high power levels. These filters should not be used without limiters at their input, where power levels in excess of 0.2 mW are expected. As better high-Q varactors are being manufactured (varactors that have Q's above 12,000 at 50 MHz), their usefulness as tuning elements at microwave frequencies will be enhanced.

## Appendix A

### Helical Resonator Design Method

Macalpine and Schildknecht<sup>3</sup> developed semi-empirical monographs and graphs for the design of helical resonators. They found that the optimum unloaded Q was obtained when the ratio of the coil diameter to the inside diameter of the shield was approximately 0.55.

Figure A1 gives typical design parameters for helical resonator shield sizes as a function of desired unloaded Q and resonance frequency. For Q and frequency values that lie outside the lower and upper dashed lines, other options than helical resonators should be pursued.

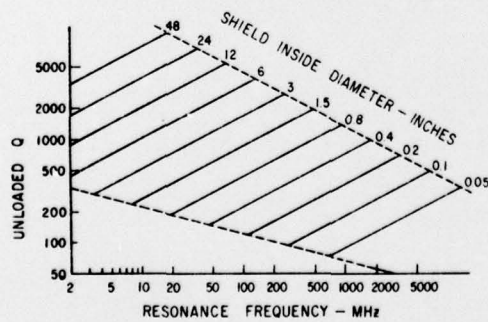

Figure A1. Diagram for Finding Unloaded Q in Helical Resonator (From Macalpine and Schildknecht, Reference 3)

Figure A2 is a design monogram for practical design and performance information for a quarter-wave-long helical resonator. (For half-wave designs, the physical parameter will have to be adjusted accordingly.) For example; if it is desired to design a helical resonator with a resonance frequency of 300 MHz, and we pick a shield inside diameter of 1 in. , we find that we will have an unloaded Q of approximately 900 (continue a straight line from 300 MHz through shield inside diameter to the right and read 900 on Q). This reading also gives us the winding pitch of the helix of 0.14 in. per turn. To find total number of turns we extend the line to the left of the 300 MHz point, through the 1-in. shield inside diameter, and find that the characteristic impedance of the device is 300 ohms. Resonators at other frequencies and impedances can easily be found in a similar manner from Figure A2.

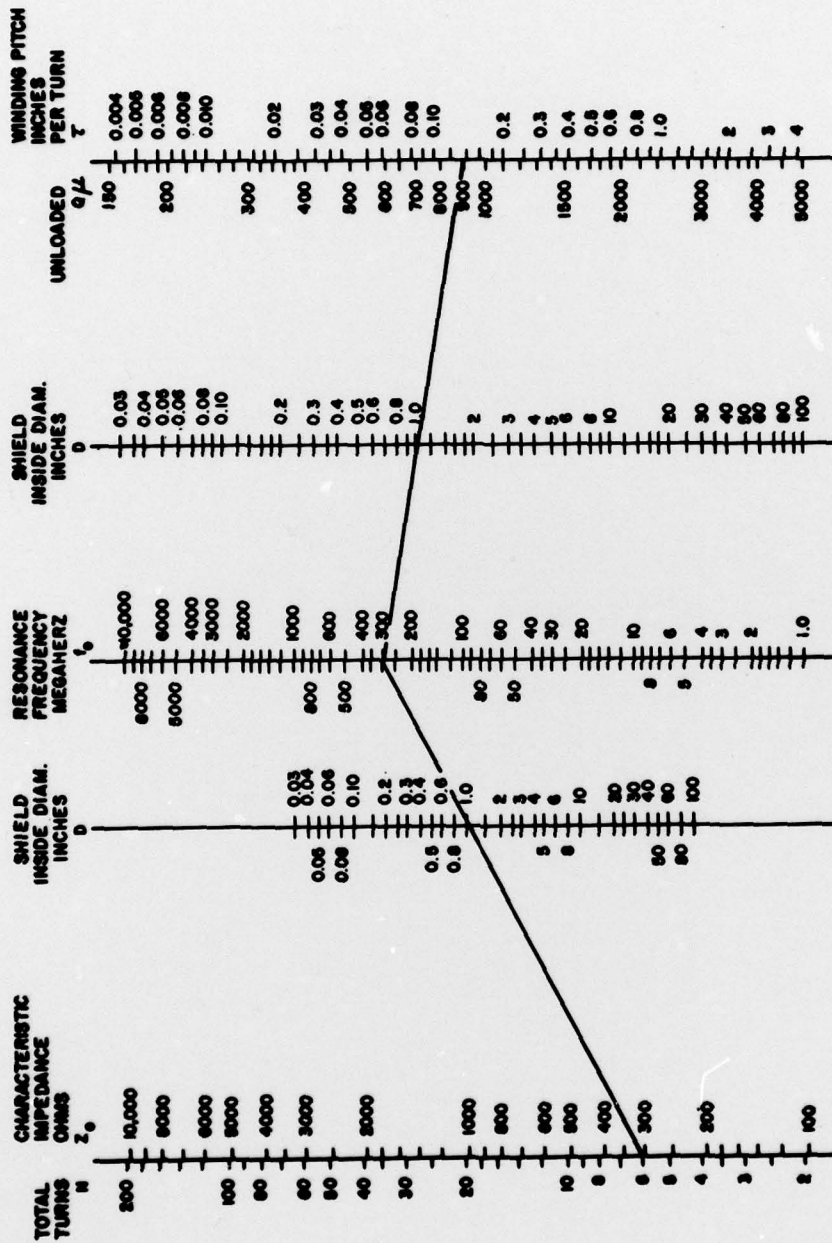

Figure A2. Design Chart for Quarter-Wave Helical Resonators (From Macalpine and Schildknecht, Reference 3)