

AD-A074 527

AIR FORCE MATERIALS LAB WRIGHT-PATTERSON AFB OH
EVALUATION OF 100 MM BORE BEARINGS AFTER ACCELERATED TESTING IN--ETC(U)
JUL 79 W E WARD
AFML-TR-79-4083

F/G 22/2

UNCLASSIFIED

NL

1 OF 1

AD
A074527

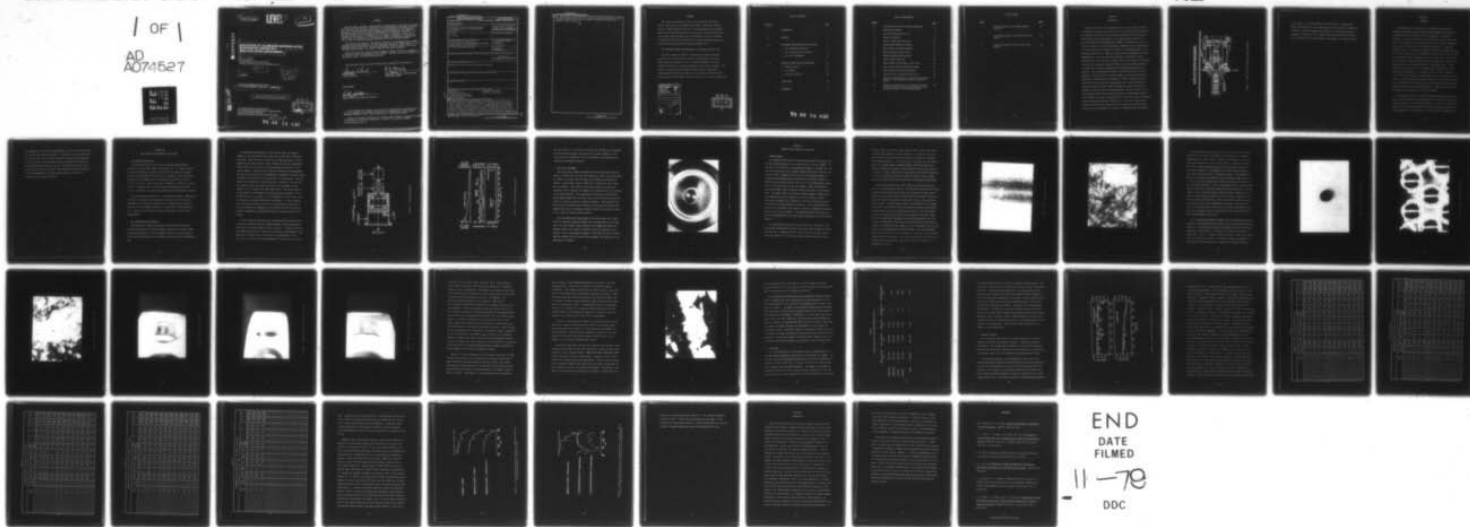

END
DATE
FILMED

11-79
DDC

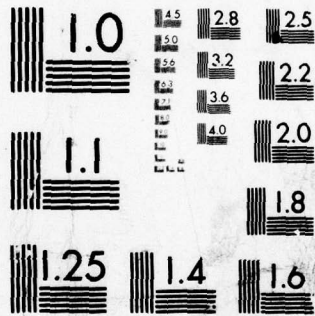

MICROCOPY RESOLUTION TEST CHART
NATIONAL BUREAU OF STANDARDS-1963-A

62102F

14

AFML-TR-79-4083

LEVEL II

B.S. 2

DA074527

6

EVALUATION OF 100 MM BORE BEARINGS AFTER ACCELERATED TESTING IN A SIMULATED SPACE ENVIRONMENT.

10

WAYNE E. WARD

NONMETALLIC MATERIALS DIVISION
FLUIDS, LUBRICANTS, AND ELASTOMERS BRANCH

1250

16 2421

17 021

11

JUL 10 1979

TECHNICAL REPORT AFML-TR-79-4083

9

Interim Report for Period October 1976 - September 1977

DDC FILE COPY

Approved for public release; distribution unlimited.

DDC
RECEIVED
OCT 2 1979
D

AIR FORCE MATERIALS LABORATORY
AIR FORCE WRIGHT AERONAUTICAL LABORATORIES
AIR FORCE SYSTEMS COMMAND
WRIGHT-PATTERSON AIR FORCE BASE, OHIO 45433

012320

79 09 24 342

JB

NOTICE

When Government drawings, specifications, or other data are used for any purpose other than in connection with a definitely related Government procurement operation, the United States Government thereby incurs no responsibility nor any obligation whatsoever; and the fact that the government may have formulated, furnished, or in any way supplied the said drawings, specifications, or other data, is not to be regarded by implication or otherwise as in any manner licensing the holder or any other person or corporation, or conveying any rights or permission to manufacture, use, or sell any patented invention that may in any way be related thereto.

This report was prepared in the Fluids, Lubricants, and Elastomers Branch (MBT), Nonmetallic Materials Division, Air Force Materials Laboratory under Project No. 2421 "Aerospace Fluid, Lubricants, and Fluid Containment," Task No. 242102 "Lubricating Materials and Tribology." Dr. Wayne E. Ward was the Project Engineer.

This report has been reviewed by the Information Office (IO) and is releasable to the National Technical Information Service (NTIS). At NTIS, it will be available to the general public, including foreign nations.

This technical report has been reviewed and is approved for publication.

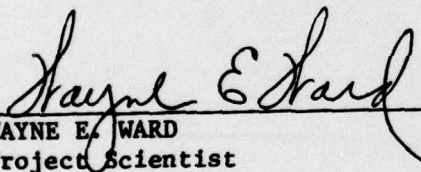
WAYNE E. WARD
Project Scientist

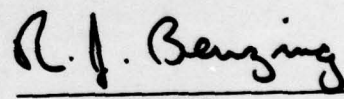
R. J. BENZING
Actg. Chief, Fluids, Lubricants and
Elastomers Branch

FOR DIRECTOR

J. M. KELBLE
Chief, Nonmetallic Materials Division

If your address has changed, if you wish to be removed from our mailing list, or if the addressee is no longer employed by your organization, please notify AFML/MBT, W-PAFB, OH 45433 to help us maintain a current mailing list.

Copies of this report should not be returned unless return is required by security considerations, contractual obligations, or notice on a specific document.

UNCLASSIFIED

SECURITY CLASSIFICATION OF THIS PAGE(When Data Entered)

type bearings which experienced such a failure during an accelerated life test. Physical, chemical, and pictorial evidence is presented to support the postulated cause of failure.



UNCLASSIFIED

SECURITY CLASSIFICATION OF THIS PAGE(When Data Entered)

FOREWORD

This report was prepared in the Air Force Materials Laboratory, Fluids, Lubricants, and Elastomers Branch (MBT), Nonmetallic Materials Division, Wright-Patterson AFB, Ohio. The investigation was performed under Project 2421, "Aerospace Fluids, Lubricants, and Fluid Containment," Task 242102, "Lubricating Materials and Tribology," Work Unit 24210201, "Accelerated Tests and Life Prediction for Space Bearing/Lubricants," and covered the period October 1976 through September 1977.

This technical report was submitted by the author in April 1979.

The author wishes to thank Mr. James Snodgrass, Midwest Research Institute, for his assistance in some of the photography and Jerold Kannel, Tom Dow, and David Snediker of Battelle Memorial Institute, Columbus Laboratories, for their assistance in the failure analyses. The bearing test apparatus was designed and the tests were performed at Southwest Research Institute under Air Force Contract F33615-73-C-5123. The assistance of Herb Carper, John Tyler, and P. M. Ku is also appreciated.

Accession For	
NTIS GRA&I	<input checked="" type="checkbox"/>
DDC TAB	<input type="checkbox"/>
Unannounced	<input type="checkbox"/>
Justification	<input type="checkbox"/>
By _____	
Distribution/	
Availability Codes	
9888	Avail and/or special.
A	

DDC
RECEIVED
 OCT 2 1979
 D

TABLE OF CONTENTS

<u>SECTION</u>		<u>PAGE</u>
I	INTRODUCTION	1
II	APPROACH	4
III	DMA BEARING TEST DESCRIPTION AND RESULTS	6
	1. Test Specimen Description	6
	2. Test Configuration and Results	6
	3. Post-Test Disassembly	10
IV	BEARING FAILURE ANALYSES AND RESULTS	12
	1. Forward Bearing	12
	2. Aft Bearing	26
	3. Lubricant Analysis	28
V	CONCLUSIONS	40
	REFERENCES	42

79 09 24 342

LIST OF ILLUSTRATIONS

<u>FIGURE</u>		<u>PAGE</u>
1	Typical Military Satellite Despin Mechanism	2
2	Bearing Test Chamber	8
3	Low Film Thickness Ratio Test	9
4	Seized Aft Bearing	11
5	"Mud" on Inner Race Ball Track	14
6	Heptane Wash Residue from Races	15
7	Ball Surface with "Mud" Deposits	17
8	Opaque Coating on Ball Surface	18
9	Heptane Wash Residue from Balls	19
10	"Mud" Outside Ball Track	20
11	"Mud" Pushed to Both Sides of Ball Track	21
12	Edge of Linen Fabric in Retainer Pocket	22
13	"Mud" Removed from Retainer Pockets	25
14	Talysurf Traces of Retainer Outer Face	29
15	Partial Infrared Spectra for Apiezon C, Formulated Apiezon C, and Formulated Apiezon C Stressed at 167°F	37
16	Partial Infrared Spectra for Formulated Apiezon C Stressed at 390°F and the Oil Recovered from the Races and Retainer of the Forward Bearing	38

LIST OF TABLES

<u>TABLE</u>		<u>PAGE</u>
1	Weight Analysis of the Forward Bearing (S/N 28)	27
2	Unformulated Apiezon C Four-Ball Wear Test Results	31
3	Formulated Apiezon C Four-Ball Wear Test Results	33

SECTION I
INTRODUCTION

Several years ago, it was recognized that it was no longer practical or desirable to perform real-time life tests on lubricated moving mechanical assemblies designed for long-term space missions and that techniques which enable accurate prediction of life expectancy and probability of successful mission accomplishment were needed. To address this need, as well as the equally critical requirement to develop a better understanding of those factors which influence the quality of performance and/or cause anomalous performance in components such as the Despin Mechanical Assembly (DMA)(Figure 1), our laboratory has developed a comprehensive, multi-phased in-house and contractual program. The initial phase of this program consisted of an extensive survey (Reference 1) of the aerospace industry including vehicle system, sub-system, and component manufacturers and sponsors. This investigation resulted in the identification of several potential causitive factors or failure modes, each requiring substantial additional investigation and confirmation. Among the potential failure modes identified were lubricant degradation, slip ring and brush wear, improper lubricant transfer, lubricant dewetting, lubricant volatility, inadequate lubricant quantity, separator wear, separator instability, etc. The potential failure mode identified as "lack of adequate DMA bearing film thickness" has been investigated and the results of this investigation have been reported previously (Reference 2). This report presents the results of the post-test analysis of test specimen ball bearings which failed to survive extended life testing in a simulated space environment

SATELLITE DESPIN MECHANISM

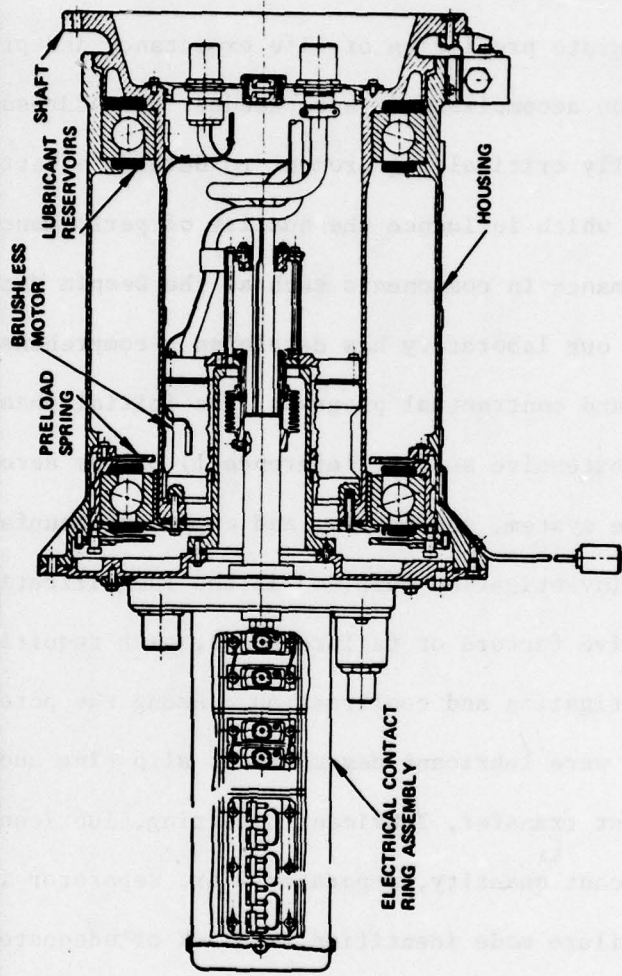

Figure 1. Typical Military Satellite Despin Mechanism

in the course of the investigation into the effects of inadequate DMA bearing film thickness. This post-mortem included superficial examination followed by careful disassembly and analysis of the individual bearing components. Each step in the sequence will be described and conclusions will be supported by physical evidence, photographs, and chemical evidence.

SECTION II

APPROACH

The investigation of the effects of variations in bearing film thickness included both short-term and long-term DMA bearing testing in a simulated space environment with some acceleration of operating parameters. In part, the latter was accomplished by varying the surface finish of the bearing races and through the use of lubricants formulated from a family of base stocks of differing viscosities. A convenient method to identify varying initial bearing conditions is through the use of the film thickness ratio, Λ , defined as the ratio of the film thickness to the composite surface roughness of the balls and races. In this way, the three initial longer-term bearing tests conducted were described as having nominally low, medium, and high film thickness ratios. After operating satisfactorily in an environment which simulated the actual operational environment, i.e. a vacuum of about 1.3×10^{-4} newton/m² (1×10^{-6} torr), for periods of approximately 5.3 and 5.9 months, respectively, the tests utilizing bearings having initial conditions described as low and medium film thickness ratios each suddenly experienced a performance excursion which manifested itself as a demand for drive torque which exceeded the capability of the drive system.

The unexpected failure of these test specimen bearings dictated the need to better understand the relationship between bearing design, operational environment, and long-term performance. To this end, a post-test analysis of the failed bearings from the test employing the initial low film thickness ratio was conducted. Initial microscopic examination of

the assembled test article was supplemented by a more in-depth evaluation of the individual bearing components. Included in this were examinations of the wear debris and lubricants recovered from the bearing components. For the most part, the techniques used were those which have been described previously (References 3 and 4). The post-test analysis led to some conclusions about the cause of the premature failures and resulted in some recommendations concerning design changes to minimize the recurrence of this type of failure.

SECTION III

DMA BEARING TEST DESCRIPTION AND RESULTS

1. TEST SPECIMEN DESCRIPTION

The bearings utilized in the low film thickness DMA performance evaluation are 440C steel, ABEC-7, 100 mm bore, $26^\circ \pm 1^\circ$ angular contact ball bearings having a relieved inner race land and specially prepared raceways of approximately $0.204 \mu\text{m}$ ($8 \mu\text{in.}$) roughness. This is approximately twice the roughness of the "standard" surface finish, which is $0.102 \mu\text{m}$ ($3\text{-}4 \mu\text{in.}$). Each bearing has a complement of 19 balls of 15.9 mm ($.625 \text{ in.}$) diameter having a surface finish of approximately $0.025 \mu\text{m}$ ($1 \mu\text{in.}$), separated by an outer land guided porous cotton phenolic retainer.

The bearings were processed, i.e., cleaned and lubricated, commercially. The metallic components were coated and the porous retainer was vacuum impregnated with a specially prepared fluid, formulated using Apiezon A base stock and containing 5 percent of a concentrate of lead naphthenate and 1.5 percent of an oxidation inhibitor identified as a p,p'-dioctyl-diphenylamine.

2. TEST CONFIGURATION AND RESULTS

The bearing test chamber was designed and constructed and bearing testing was performed at Southwest Research Institute, San Antonio, Texas. A detailed description of the test chamber as well as the test procedure can be found in Reference 2 and, therefore, will be but briefly summarized here.

The bearings were installed in the stainless steel test chamber (Figure 2) and loaded against each other with an 890 newton (200 pound) axial load. The outer race of one of the bearings was placed in a diaphragm to which was attached a linear variable differential transformer (LVDT), while the outer race of the other bearing was placed in a stationary housing. During the test, speed was maintained at approximately 100 rpm via the utilization of a magnetically coupled DC drive motor having a maximum torque capacity of 0.64 newton meter (90 ounce-inch). The test chamber was equipped with a solid base plate containing a 1 cm hole and the simulated space environment was attained via attachment of this chamber to an ion pumped ultra high vacuum system. The vacuum obtained in this manner was maintained at the equilibrium vapor pressure of the formulated fluid, i.e., about 1.3×10^{-4} newton/m² (1×10^{-6} torr), thus simulating the anticipated operational environment. In this configuration, the bearing whose outer race is in the diaphragm and adjacent to the vacuum chamber is designated as the "forward" bearing; the bearing nearest the magnetically coupled drive motor is designated as the "aft" bearing.

The test conducted utilizing this system operated satisfactorily for a period of 3,836 hours with the chamber pressure, bearing temperatures, and total drive torque varying as shown in Figure 3. During this period, the minimum film thickness, calculated from measured displacements of the LVDT core, increased from an initial value of approximately 0.07 μm (2.7 $\mu\text{in.}$) to a final value of approximately 0.17 μm (6.9 $\mu\text{in.}$) for one

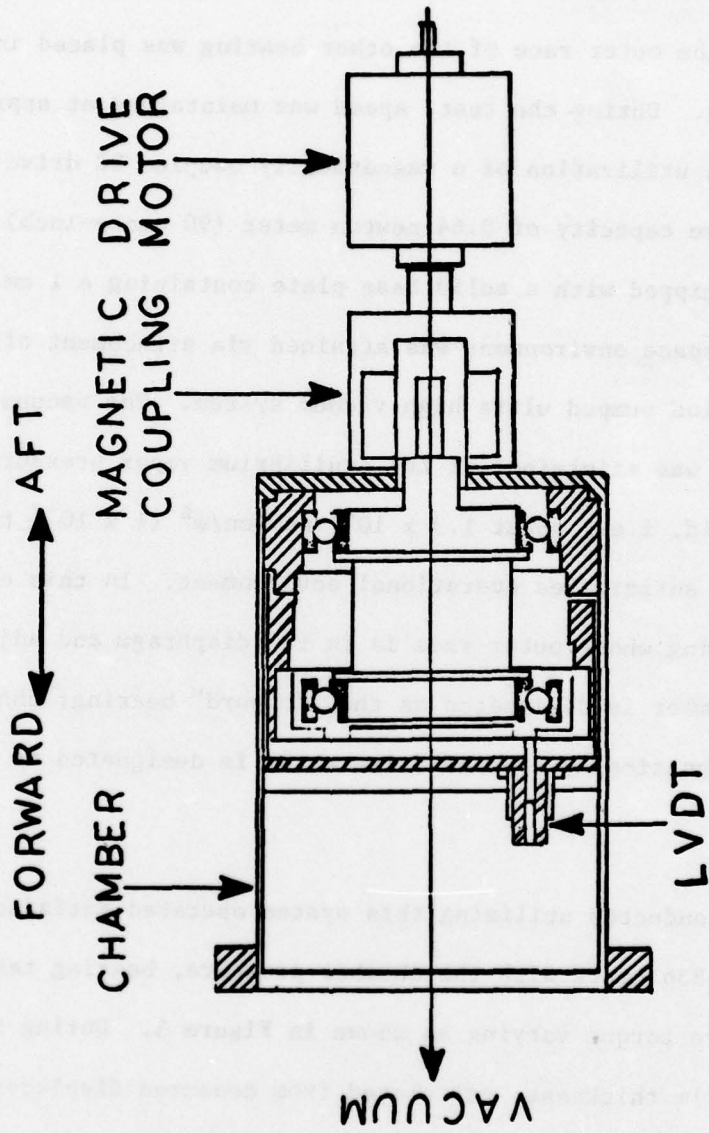

Figure 2. Bearing Test Chamber

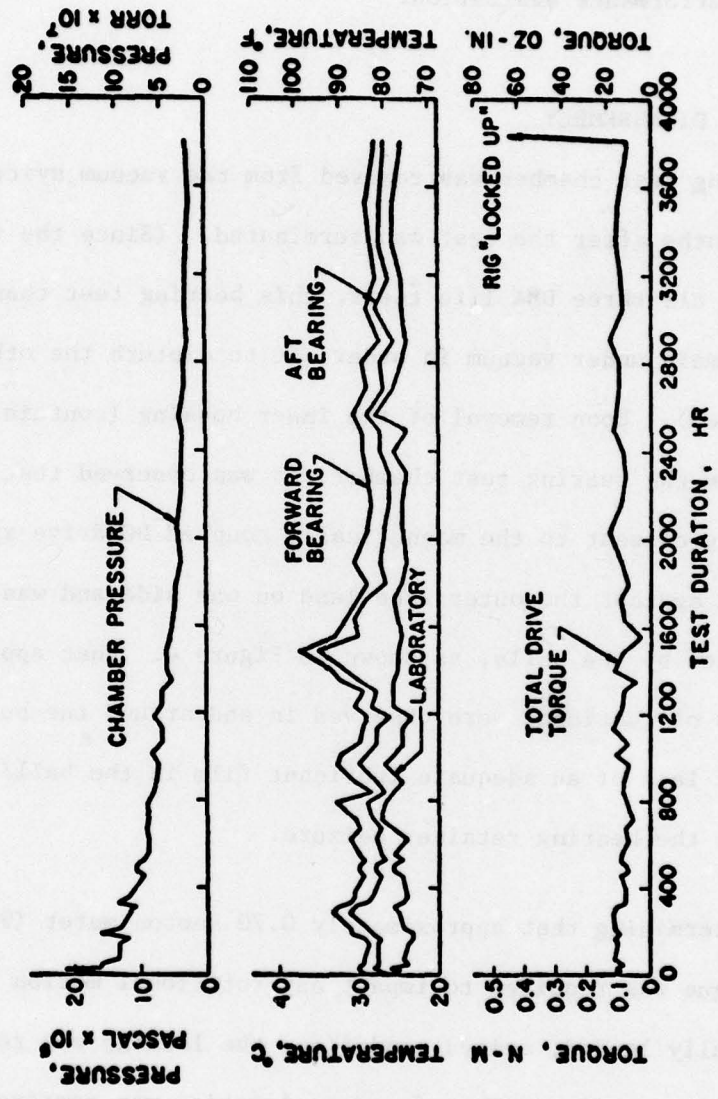

Figure 3. Low Film Thickness Ratio Test

ball race contact. At the end of this period of satisfactory performance, the test bearings suddenly and without prior warning demanded a drive torque beyond the capability of the drive system, thus terminating the accelerated performance evaluation.

3. POST-TEST DISASSEMBLY

The bearing test chamber was removed from the vacuum system approximately 2.5 months after the test was terminated. (Since the vacuum system was common to all three DMA life tests, this bearing test chamber was allowed to remain under vacuum in order not to disturb the other tests, which continued). Upon removal of the inner housing (containing the bearings) from the bearing test chamber, it was observed that the retainer of the bearing closest to the magnetically coupled DC drive system had become wedged against the outer race land on one side and was being held firmly in place by the balls, as shown in Figure 4. What appeared to be ample amounts of lubricant were observed in and around the bearing which suggests that lack of an adequate lubricant film in the ball/race contact did not cause the bearing retainer seizure.

After determining that approximately 0.70 newton meter (99.7 ounce-inch) of torque was required to impart any rotational motion to the bearing in the fully loaded, seized condition, the loading was removed in a stepwise fashion until complete freedom of motion was restored to the bearing. After an unsuccessful attempt to reinitiate the test, the bearings were removed from the inner housing, packaged, and delivered to our laboratory for analysis.

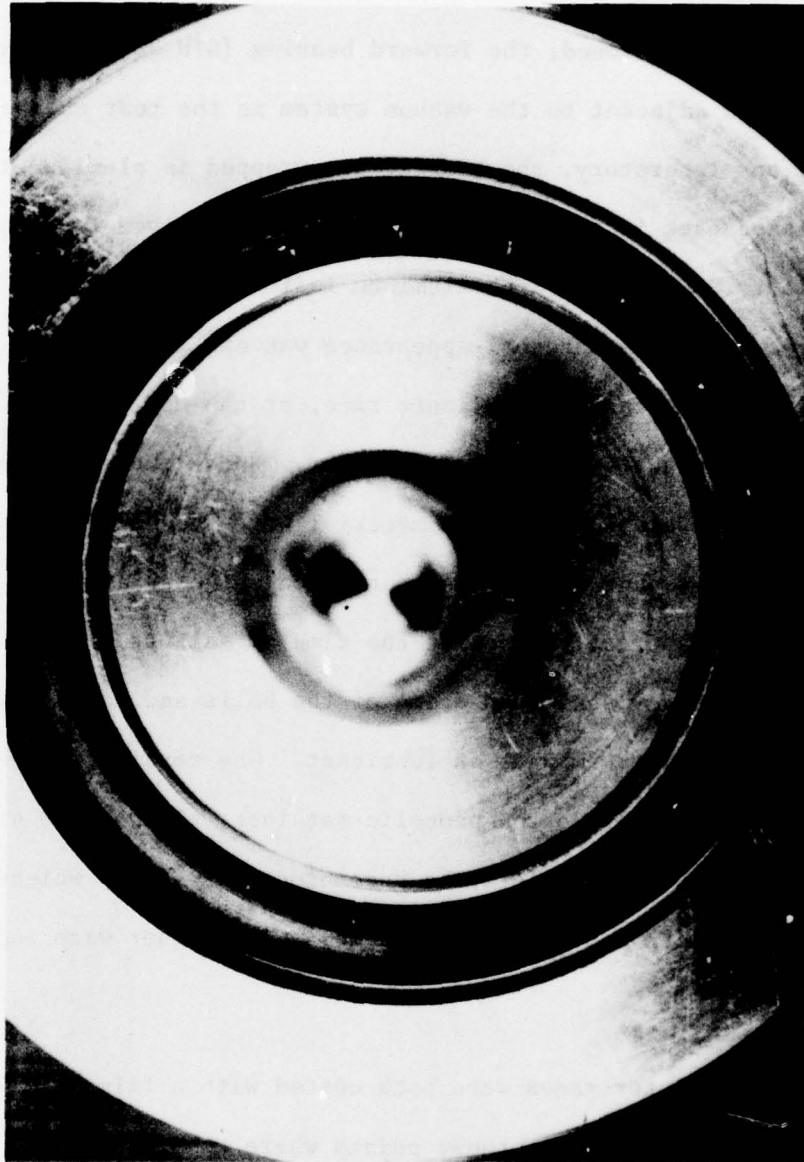

Figure 4. Seized Aft Bearing

SECTION IV

BEARING FAILURE ANALYSES AND RESULTS

1. FORWARD BEARING

As previously mentioned, the forward bearing (S/N 28) was that which had been located adjacent to the vacuum system in the test chamber. As received in our laboratory, the bearing was wrapped in aluminum foil and had been placed back in the original plastic bag received from the lubrication facility. Removal of the aluminum foil wrapping revealed an assembled bearing whose external appearance was excellent except for a darkened area on the face of the inner race, at the mating point between the race and drive shaft in the test chamber. Under the microscope, intermittent small areas of removed material were seen in this darkened area. This small amount of fretting corrosion suggests a slight amount of slippage had occurred, perhaps at the time of seizure. Before disassembly, unaided visual inspection of the balls and races revealed the presence of copious amounts of lubricant. The retainer appearance was that of a lubricated cotton phenolic retainer, although no significant quantities of oil were visible. The assembled bearing was weighed and then was disassembled and the races, balls, and retainer were individually examined.

The inner and outer races were both coated with a film of oil, with the greatest concentration at those points where they had been in contact with the balls. Throughout both the inner and outer race ball tracks, there were deposits of solid, black material mixed with and/or coated

with oil, which, for lack of a more precise term, we have called "mud." A typical "mud" deposit is shown in Figure 5. In addition, the inner race surface contained some fibrous material and some shiny fragments, which appeared metallic. For the most part, the "mud" and other debris were easily removed under a heptane pressure rinse with the aid of a rubber policeman, after which it was collected on filter paper as shown in Figure 6. After cleaning in the above manner, microscopic examination of the races failed to reveal any evidence of metallic wear; grinding marks were easily visible and even the ball track appeared undisturbed.

Although the origin of this "mud" cannot be determined absolutely, there are several possible sources. The bearings could have been contaminated during the lubrication process, but, because of the many years of experience in the fabrication and lubrication of all types of space hardware available at the commercial lubrication facility, this possibility seems unlikely. Another possible source of contamination is the experiment itself. The stainless steel test chamber, however, was thoroughly cleaned before use and, as can be seen in Figure 2, the test specimen bearings are isolated both from the drive system and the LVDT. Torque data was obtained from the magnetic coupling and temperature data from a passive thermocouple. There was no data transfer (via slip-rings, for example) from inside the test chamber, so that the possibility of contamination from the experiment seems equally remote. The only reasonable explanation, therefore, is that the "mud" is a mixture of finely divided retainer debris and lubricant. The black appearance may be the result of degradation of the lubricant, the particle size of the debris, or a combination of these.

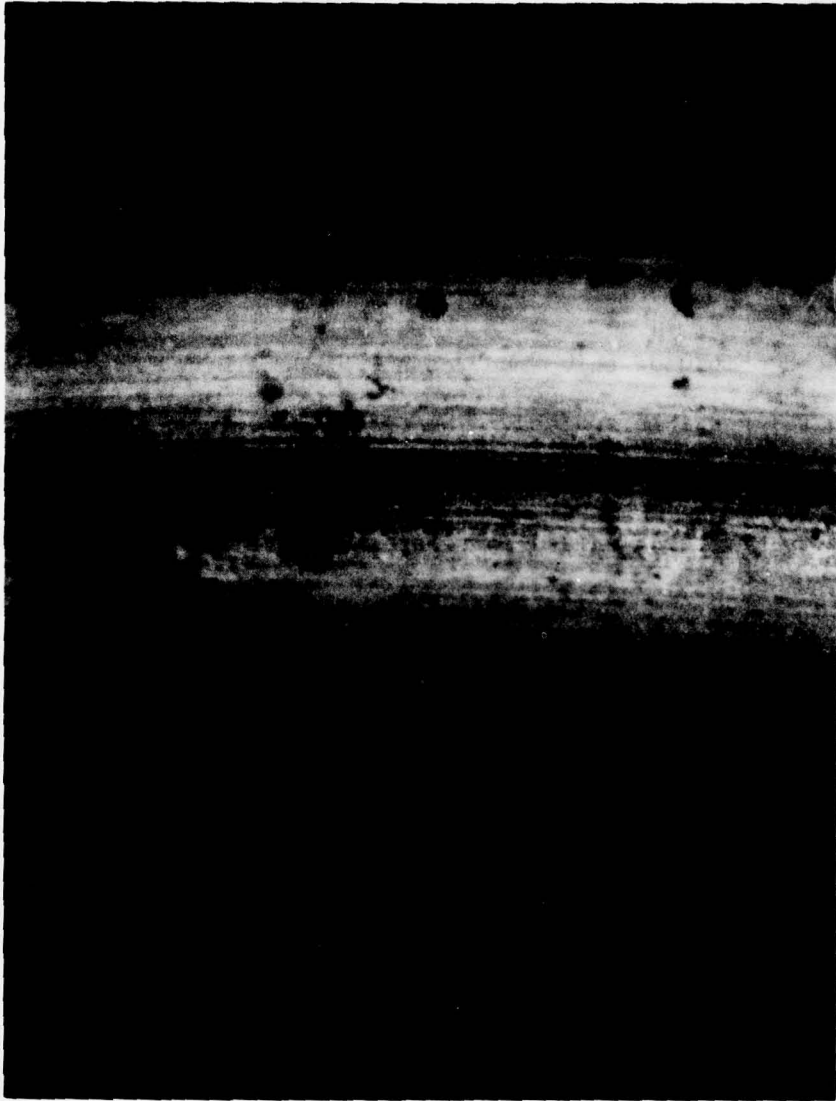

Figure 5. "Mud" on Inner Race Ball Track



Figure 6. Heptane Wash Residue from Races

The balls were also covered with a film of oil, and, like the races, deposits of black "mud" were visible on the surfaces, but in smaller concentrations. Figure 7 shows a portion of the surface of one of the balls with mud deposits in an oil film visible. In addition, several balls had an opaque coating and were not as reflective as the others. For example, Figure 8 is a photograph of a group of balls illuminated both right and left by a bank of fluorescent lights. In comparing the dark vertical center line between the two fluorescent light reflections, it can be seen that the center ball contains an opaque coating absent in the remainder of the balls. This coating appeared to be a finely divided material mixed with oil and was easily removed by wiping after a heptane pressure rinse. Under microscopic examination after cleaning, the ball surfaces appeared in good condition for the most part. Several ball surfaces had minor scratches and at least one ball had two small gouges but no pitting or other surface degradation was evident. As was the case with the races, the debris collected on filter paper from washing of the balls was a mixture of "mud," fibrous material, and a few shiny flakes which appeared metallic (Figure 9).

Of all the bearing components examined, the cotton phenolic separator appeared to have suffered the most damage from the accelerated performance evaluation. Like the balls and races, the retainer also had considerable quantities of black "mud" in and around the ball pockets as shown in Figures 10, 11, and 12. Figure 10 shows a quantity of "mud" to the right of the ball track in the pocket. The debris in Figure 11 appears to be the result of a ball rolling over a large piece of "mud" and pushing

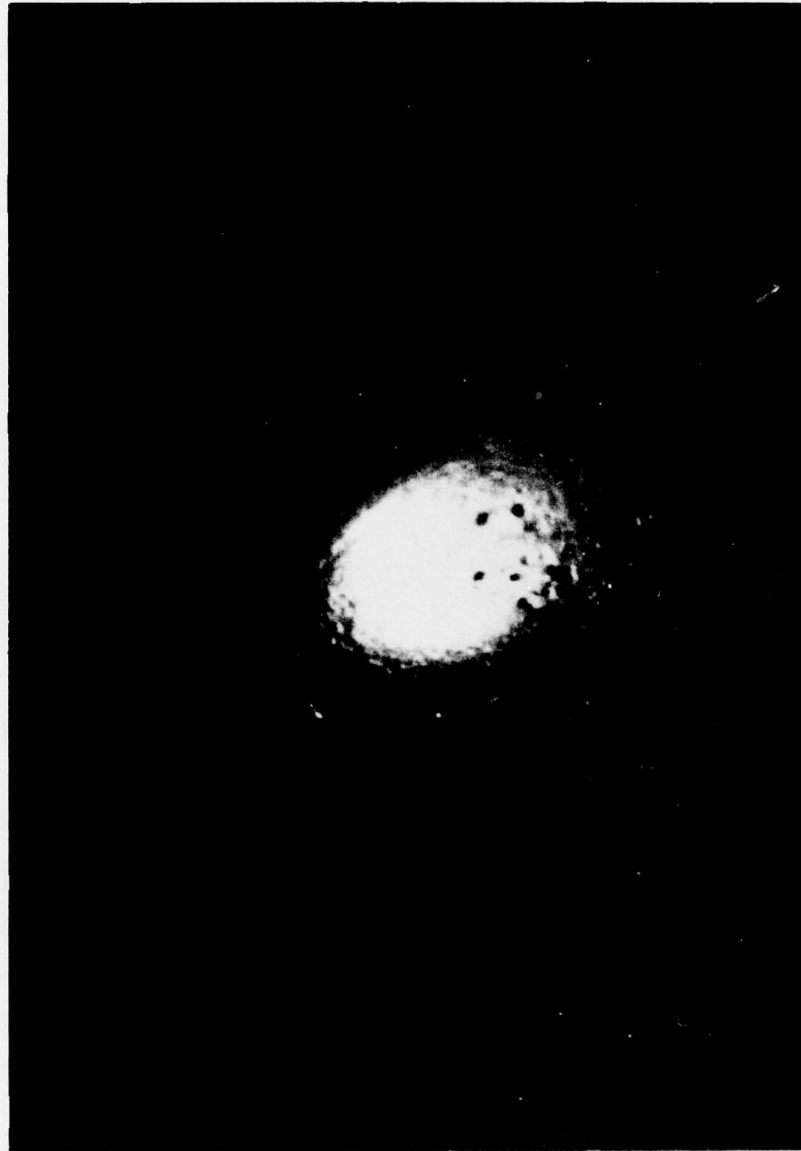

Figure 7. Ball Surface with "Mud" Deposits

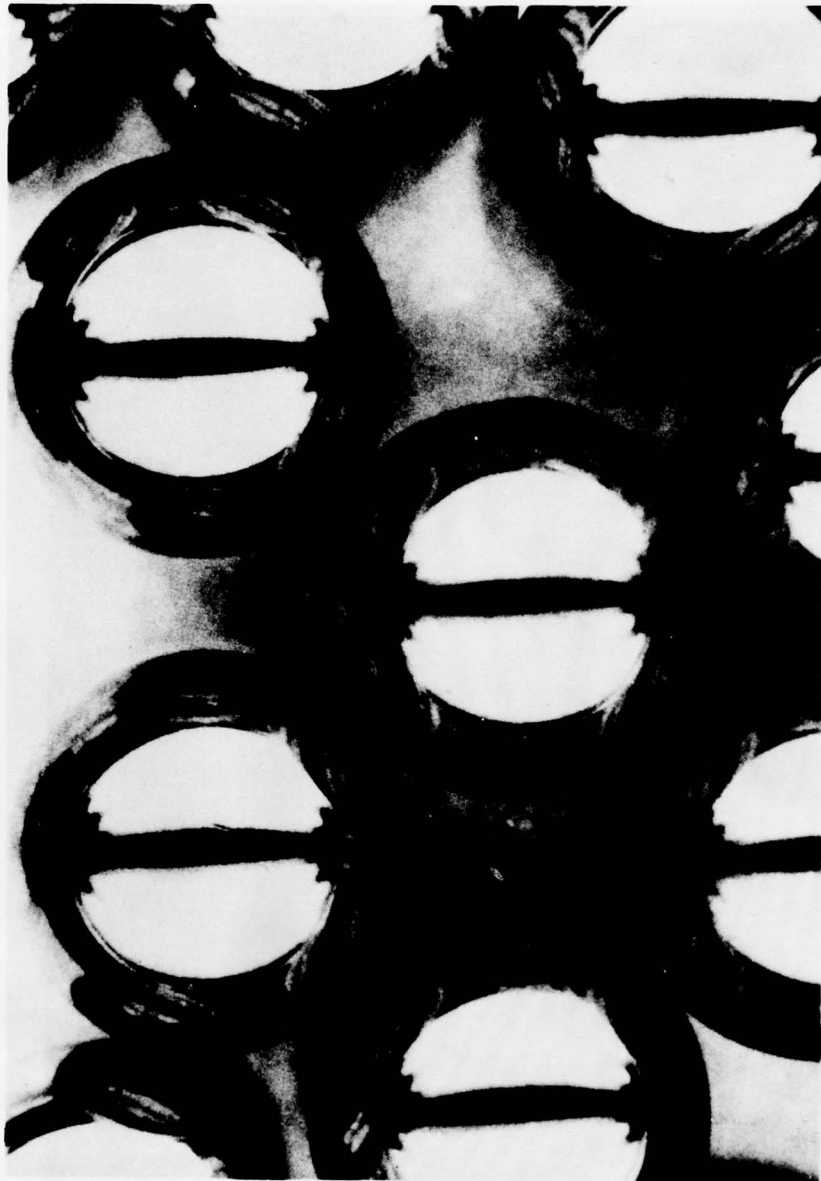

Figure 8. Opaque Coating on Ball Surface

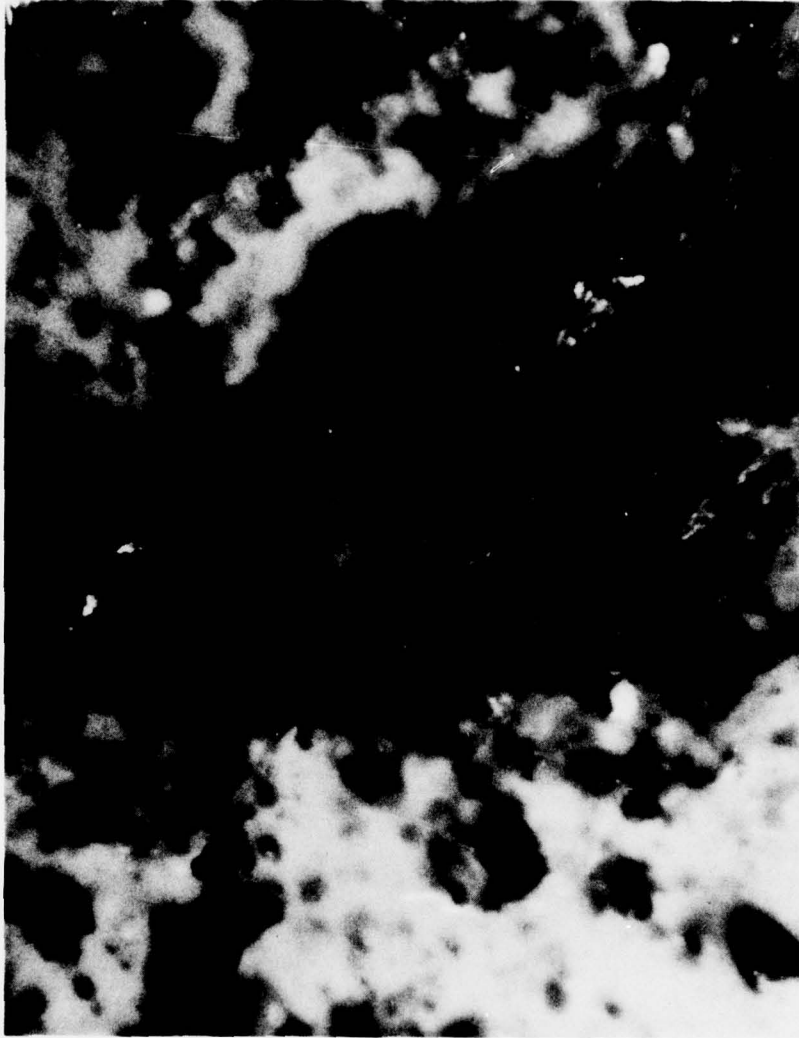

Figure 9. Heptane Wash Residue from Balls

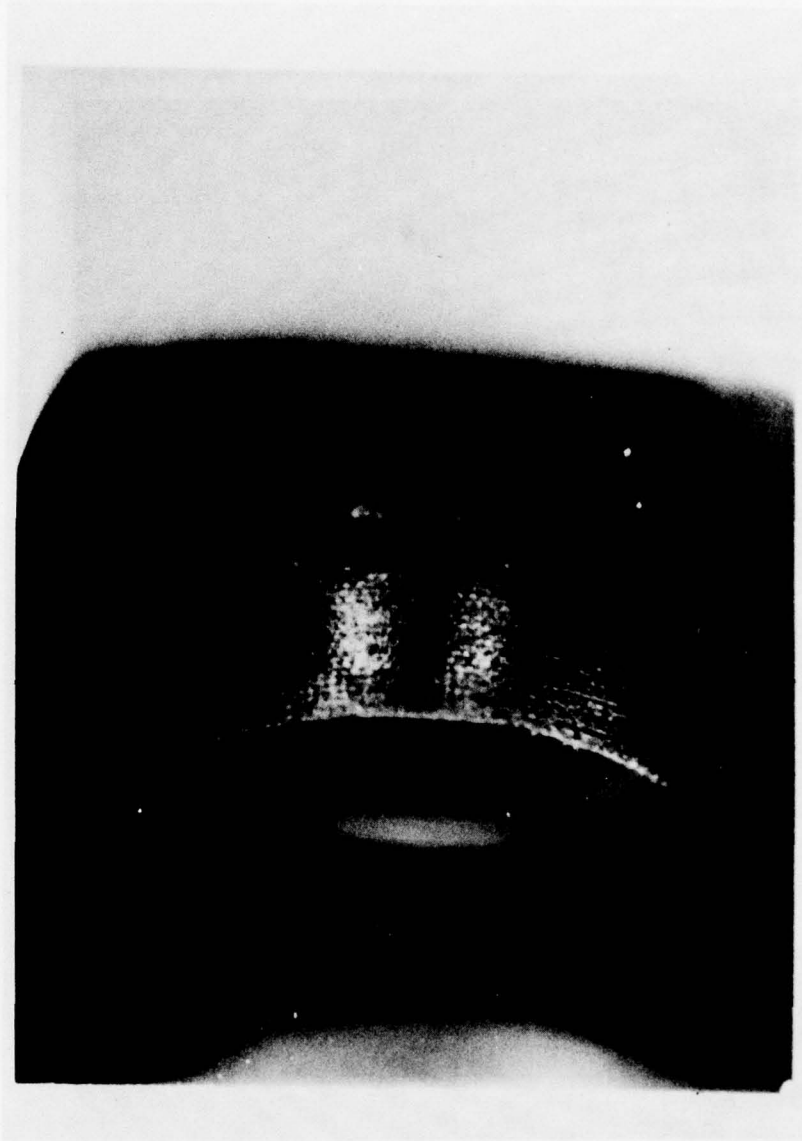

Figure 10. "Mud" Outside Ball Track



Figure 11. "Mud" Pushed to Both Sides of Ball Track

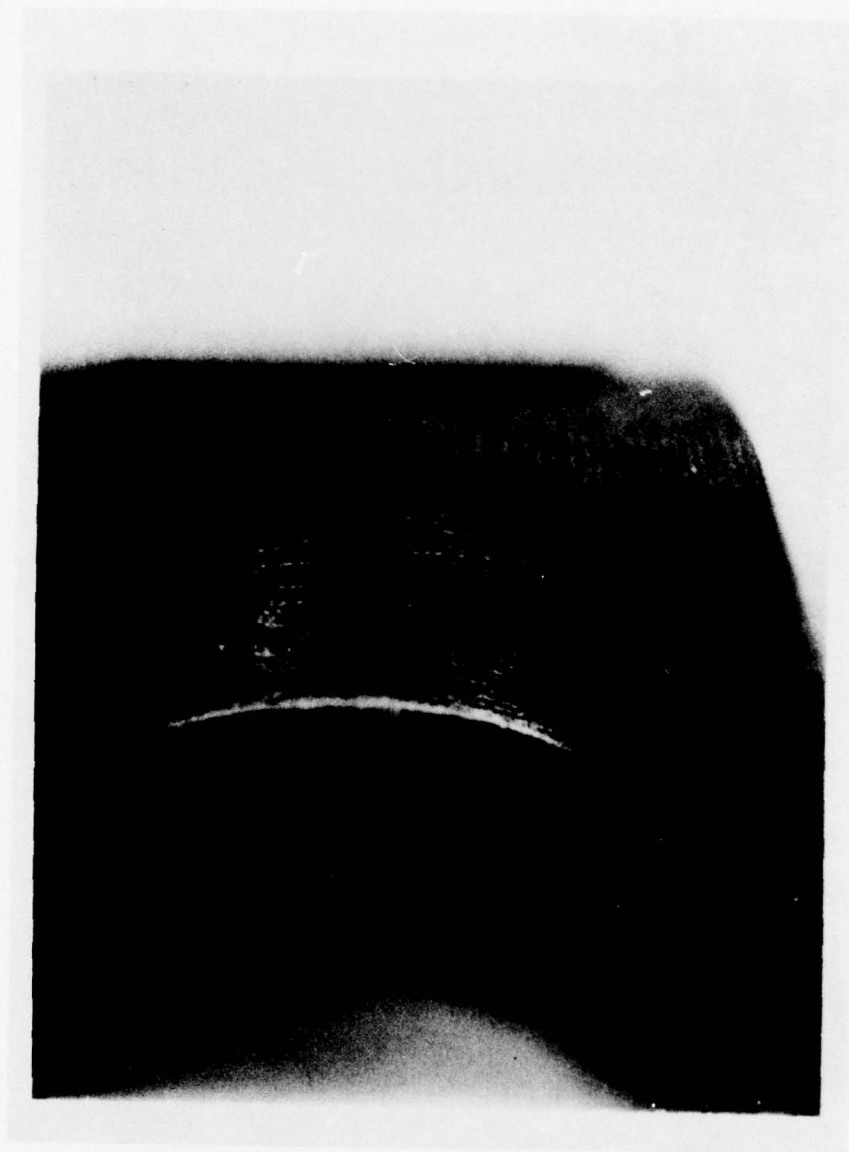

Figure 12. Edge of Linen Fabric in Retainer Pocket

portions of it out on both sides of the ball track. Interestingly, every retainer pocket had a black ball track partially, or completely, around its inner circumference. From Figure 11, one might conclude that this black ball path is the result of "mud," which enters the ball track, being moved around the pocket by the ball. This suggests that every ball pocket had "mud" in it at some time. More serious, is the question of why the ball tracks in the individual pockets show so much variation. In all cases, both the front and rear portions of the ball pockets in the plane of rotation were darkened. When examining the top and bottom of the individual ball pockets, i.e., the portions perpendicular to the plane of rotation, no consistent ball track could be found. Almost equal numbers of pockets contained a complete ball track around 360 degrees of the inner circumference as did not. These findings are not inconsistent with a postulate of considerable retainer instability and out of plane motion. Although in this case there is no documented evidence to support this theory, future in-house experimental investigations will address the critical question of retainer motion and instability and, with the aid of an advanced bearing dynamics computer program, will provide answers to this type of fundamental question.

Figure 12 is most interesting, not only because of the piece of "mud" outside the ball track, but also because of the clearly visible fabric edge running from the upper inside to the lower outside of the pocket. The presence in the ball pocket of the edge of the linen fabric has been noted previously (Reference 3) and the question of its impact on performance was raised. From Figure 12, it would appear that no preferential

wear, pitting, or other damaging phenomena has occurred at this site, suggesting that, in this case, its presence in the pocket was not detrimental. Also visible, particularly in Figures 11 and 12, are black areas on the outside face of the retainer near the ball pockets. These dark areas which were visible near eleven of the nineteen pockets, are, by analogy to the ball pockets themselves, areas in which wear has taken place in the presence of "mud." Considering the nature of the bearing failure, i.e., seizure due to excessive retainer instability, and the obvious rubbing of the retainer face against the outer race land, the adequacy of the lubrication at these sites is questionable.

The "mud" in the pockets was removed by carefully lifting each large piece with a spatula and placing it on a piece of filter paper, after which the retainer was cleaned in a soxhlet extractor using 8000 ml of filtered heptane. Under microscopic examination (Figure 13), the "mud" appears to be finely divided retainer debris, some of which is still orange in color, mixed with darker debris and oil.

As previously mentioned, the balls and races were each pressure rinsed separately with heptane and the rinse solution was filtered leaving debris typified by that in Figures 6 and 9. Among this debris, there was a total of about four shiny metallic looking flakes. Attempts to pick up these flakes with a pointed magnet were unsuccessful. The fact that the flakes were not magnetic suggests that perhaps they were flakes of aluminum foil that found their way into the bearing from packaging. Surprisingly, some pieces of black debris were attracted to the magnet. At this time, it is



Figure 13. "Mud" Removed from Retainer Pockets

not known whether this is due simply to a static charge on the small piece of debris or to the fact that some very fine metallic wear particles from the bearing may also be imbedded in the "mud."

The rinse solutions from the balls and races and the heptane from the Soxhlet extractor were each concentrated on a Buchi evaporator to yield the varying amounts of oil as shown in the weight analysis of the forward bearing in Table 1. The weight of the complete bearing before disassembly and cleaning was 1205.6930 g which compares well with the total weight of 1205.9920 g after disassembly. From Table 1, it can be seen that approximately 88% of the total weight lost from the bearing during cleaning was from the retainer and approximately 75% of this was recovered. Based upon the weight loss during cleaning, the absorptivity of the retainer was approximately 5.86%. Because the weight of the retainer before lubrication is unknown, the weight of material worn from the retainer itself cannot be determined. Based on the weight of recovered debris, however, this value is probably less than 0.2 percent of the original weight of the retainer.

2. AFT BEARING

The aft bearing (S/N 27) is that which had been located adjacent to the magnetically coupled DC drive system in the bearing test chamber. For the most part, the disassembly procedures and observations concerning the presence of "mud" are the same as already discussed for the forward bearing. However, there are some differences. For example, no evidence of fretting corrosion was visible under microscopic examination of the face of the inner race, as was apparent with the forward bearing; yet the amount

TABLE 1

WEIGHT ANALYSIS OF THE FORWARD BEARING (S/N 28)

	BEFORE CLEANING (g)	AFTER CLEANING (g)	WEIGHT LOSS (g)	RECOVERED OIL (g)	RECOVERED DEBRIS (g)
OUTER RACE	530.2584	530.1205	0.1379	0.2	0.002
INNER RACE	326.7652	326.6351	0.1301		
19 BALLS	305.2664	305.2040	0.0624	0.1	0.001
RETAINER	43.7020	41.2822	2.4198	1.8	0.010
TOTAL	1205.9920	1203.2418	2.7502	2.1	0.013

of collected debris which had a metallic appearance seemed greater. The ball track on the inner race was more easily visible and had a slight discoloration. Under microscopic examination, the grinding marks on this race were quite visible but the ball track showed evidence of damage in the form of many small indentations, some severe, but most hardly visible. As with the forward bearing, the balls appeared slightly scratched but their overall condition was excellent. Once again, the retainer showed the most wear. In addition to the "mud" in the ball pocket, the outer face of this retainer also contained the blackened areas which had rubbed against the outer race land. Figure 14 shows Talysurf traces of a non-discolored portion of the retainer face and of a blackened portion of the retainer face, respectively. As can be seen, more retainer wear is evident in the blackened area.

3. LUBRICANT ANALYSIS

One of the major objectives of our overall program is to evaluate lubricant performance and chemical integrity in simulated operational environments. The bearings which underwent the accelerated performance evaluation described above provided an initial opportunity to perform such an evaluation, which will be discussed in the paragraphs that follow.

As previously mentioned, the disassembled balls and races of the forward bearing were pressure rinsed with heptane, which was concentrated to yield 100 mg and 200 mg of fluid each from the balls and races, respectively. The retainer was also cleaned, generally in accordance with the procedures outlined in References 3 and 4, to yield 1.8 g of a clear, orange colored fluid. The original lubricant in this bearing was Apiezon A

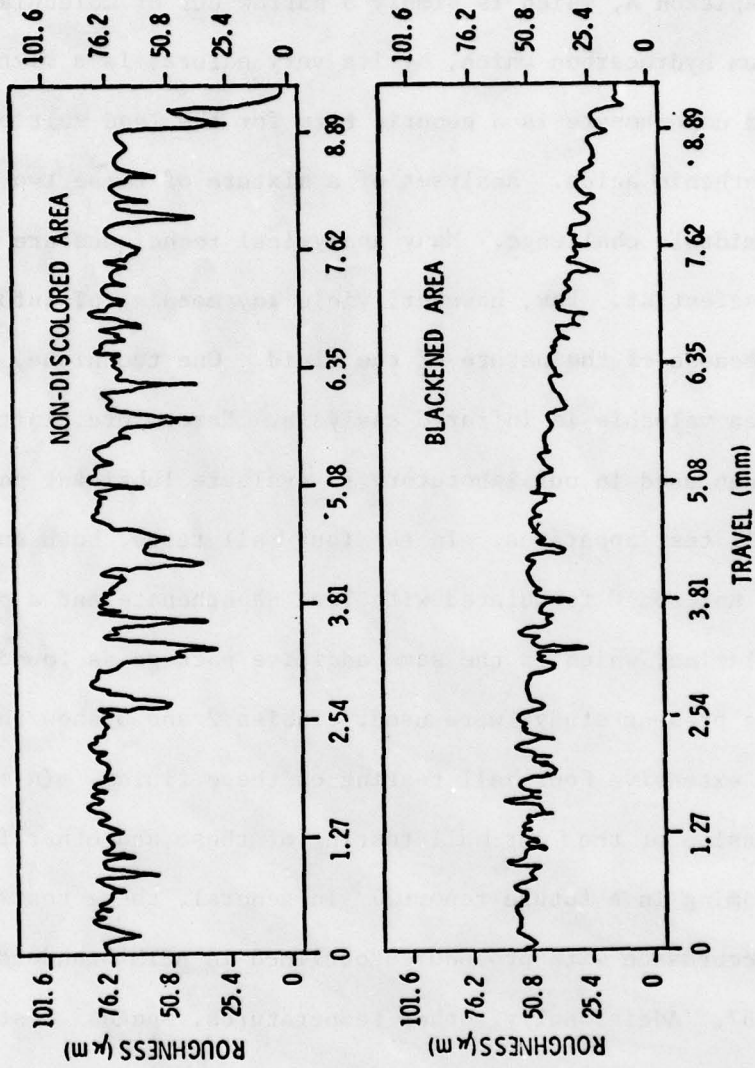

Figure 14. Talysurf Traces of Retainer Outer Face

formulated with 5% of a concentrate of lead naphthenate and 1.5% of a p,p'-dioctyldiphenylamine. In all probability, none of these is a pure material having a single chemical structure and formula. This is true, certainly, of Apiezon A, which is simply a narrow cut of molecularly distilled petroleum hydrocarbon which, by its very nature, is a mixture. Similarly, lead naphthenate is a generic term for the lead salt of a mixture of naphthenic acids. Analyses of a mixture of these two materials, then, is a formidable challenge. Many analytical techniques are available to the modern scientist. Few, however, yield any meaningful information in this case because of the nature of the fluid. One technique, however, which has proven valuable is infrared analysis. Heretofore, infrared analysis has been used in our laboratory to evaluate lubricant performance in the four-ball test apparatus. In the four-ball tests, both Apiezon C base stock and Apiezon C formulated with lead naphthenate and a p,p'-dioctyldiphenylamine, which is the same additive package as found in the bearings in the present study, were used. Tables 2 and 3 show the results of some of the extensive four-ball testing of these fluids. (A more complete discussion of the four-ball testing of these and other fluids will be forthcoming in a future report.) In general, these tests were conducted in accordance with procedures outlined in ASTM Standard Test Method D-2266-67. Additionally, other temperatures, speeds, test times, and loads were also employed. Generally, the results indicate that the wear scar diameter can be heavily influenced by load, temperature, or speed and that no single factor is dominant over the range of conditions examined. Also, care must be exercised in the interpretation of the wear

TABLE 2

UNFORMULATED APIEZON C FOUR-BALL WEAR TEST RESULTS

TEST NO.	NO. OF TESTS	BALL MAT'L	TIME (HR)	TEMP (°F)	SPEED (RPM)	LOAD (KG)	AVG WEAR SCAR (mm)	σ	2 σ	3 σ	AVG \pm 3 σ	AVG \pm 2 σ
1	2	52100	1.5	167	600	10	.642	.004	.007	.011	.631	.634
											.652	.649
2	4	52100	2	167	600	10	.655	.061	.123	.184	.471	.532
											.839	.778
3	4	52100	2	167	600	40	.891	.036	.072	.108	.783	.819
											.999	.963
4	2	52100	2	167	600	75	1.172	.012	.024	.036	1.135	1.147
											1.207	1.196
5	16	52100	1	167	1200	40	.796	.071	.142	.213	.583	.654
											1.009	.937
6	4	52100	2	167	1200	10	.668	.041	.083	.124	.544	.585
											.792	.750
7	4	52100	2	167	1200	40	1.025	.029	.057	.086	.940	.968
											1.111	1.082
8	4	52100	2	167	1200	75	2.164	.060	.121	.181	1.983	2.043
											2.345	2.285
9	4	52100	2	390	600	10	.366	.012	.024	.066	.329	.341
											.402	.390
10	6	52100	2	390	600	40	1.124	.191	.382	.573	.551	.742
											1.697	1.506
11	4	52100	2	390	600	75	1.428	.159	.318	.477	.951	1.110
											1.905	1.746
12	4	52100	2	390	1200	10	.392	.040	.079	.119	.273	.313
											.570	.471

TABLE 2 (Continued)

UNFORMULATED APIEZON C FOUR-BALL WEAR TEST RESULTS												
TEST NO.	NO. OF TESTS	BALL MAT'L	TIME (HR)	TEMP (°F)	SPEED (RPM)	LOAD (KG)	AVG WEAR SCAR (mm)	σ	2σ	3σ	AVG $\pm 3\sigma$	AVG $\pm 2\sigma$
13	2	52100	2	390	1200	40	1.896	.013	.027	.040	1.851 1.932	1.865 1.912
14	2	52100	2	390	1200	75	2.893	.158	.317	.475	2.418 3.368	2.576 3.210
15	2	440C	1.5	167	600	10	.285	.023	.047	.070	.215 .355	.238 .331
16	4	440C	2	167	600	10	.273	.017	.033	.050	.223 .322	.239 .306
17	6	440C	2	167	600	40	.818	.199	.397	.596	.222 1.414	.421 1.215
18	2	440C	2	167	600	75	2.920	.185	.371	.556	2.364 3.476	2.550 3.291
19	4	440C	2	167	1200	10	.350	.040	.080	.119	.230 .469	.270 .429
20	3	440C	2	167	1200	40	4.317	.091	.181	.272	4.046 4.589	4.136 4.498
21	4	440C	2	390	600	10	.593	.065	.129	.194	.464 .722	.528 .656
22	2	440C	2	390	600	40	2.428	.019	.038	.057	2.370 2.485	2.389 2.466
23	6	440C	2	390	1200	10	1.537	.152	.304	.456	1.081 1.992	1.233 1.840
24	4	440C	2	390	1200	40	2.460	.770	1.593	2.309	.151 4.769	.921 3.999

TABLE 3

FORMULATED APIEZON C FOUR-BALL WEAR TEST RESULTS

TEST NO.	NO. OF TESTS	BALL MAT'L	TIME (HR)	TEMP (°F)	SPEED (RPM)	LOAD (KG)	AVG WEAR SCAR (mm)	σ	2σ	3σ	AVG $\pm 3\sigma$	AVG $\pm 2\sigma$
1	2	52100	1.5	167	600	10	.515	.013	.025	.038	.477	.460
											.553	.540
2	2	52100	2	167	600	10	.569	0	0	0	.569	.569
3	2	52100	2	167	600	40	.629	0	0	0	.629	.629
4	4	52100	2	167	600	75	1.013	.012	.023	.035	.978	.990
											1.048	1.036
5	8	52100	1	167	1200	40	.567	.010	.020	.030	.536	.547
											.597	.587
6	4	52100	2	167	1200	10	.678	.050	.100	.149	.526	.576
											.825	.775
7	2	52100	2	167	1200	40	.715	.036	.072	.108	.606	.642
											.823	.787
8	6	52100	2	167	1200	75	1.300	.313	.627	.940	.360	.673
											2.240	1.927
9	4	52100	2	390	600	10	.675	.019	.038	.057	.618	.637
											.731	.712
10	4	52100	2	390	600	40	.961	.052	.104	.155	.805	.857
											1.116	1.064
11	4	52100	2	390	600	75	1.123	.032	.065	.097	1.026	1.058
											1.220	1.187
12	6	52100	2	390	1200	10	.657	.043	.087	.130	.527	.571
											.787	.744

TABLE 3

FORMULATED APIEZON C FOUR-BALL WEAR TEST RESULTS (Continued)												
TEST NO.	NO. OF TESTS	BALL MAT'L	TIME (HR)	TEMP (°F)	SPEED (RPM)	LOAD (KG)	AVG WEAR SCAR (mm)	σ	2 σ	3 σ	AVG \pm 3 σ	AVG \pm 2 σ
13	8	52100	2	390	1200	40	1.249	.222	.445	.667	.582	.804
											1.916	1.693
14	4	52100	2	390	1200	75	1.421	.097	.193	.290	1.132	1.228
											1.711	1.614
15	2	440C	1.5	167	600	10	.639	.006	.011	.017	.622	.628
											.656	.650
16	2	440C	2	167	600	10	.767	.006	.011	.017	.750	.756
											.784	.778
17	2	440C	2	167	600	40	1.038	.080	.059	.089	.949	.979
											1.127	1.097
18	2	440C	2	167	600	75	1.823	.115	.231	.346	1.477	1.592
											2.168	2.053
19	2	440C	2	167	1200	10	.939	.035	.071	.106	.833	.868
											1.045	1.010
20	4	440C	2	167	1200	40	2.385	.219	.438	.657	1.727	1.947
											3.043	2.824
21	2	440C	2	167	1200	75	2.453	.028	.057	.085	2.368	2.396
											2.538	2.509
22	2	440C	2	390	600	10	.979	.006	.013	.019	.959	.966
											.998	.991
23	2	440C	2	390	600	40	1.434	.010	.020	.030	1.404	1.414
											1.464	1.454
24	2	440C	2	390	600	75	1.728	.064	.129	.193	1.534	1.599
											1.921	1.856

data. An approach we have found useful is to compare bands of data which are two times the standard deviation about the average wear scar rather than to compare the average wear scars themselves. In this way, some accounting is made for the variations inherent in the test procedures and real differences in wear scar can be discussed with a confidence level of 95%.

Samples of some of these fluids tested in the four-ball apparatus at 600 rpm for 2 hours under conditions of 75°C (167°F), 10 kg load; 75°C (167°F), 40 kg load; 75°C (167°F), 75 kg load; and 200°C (390°F), 10 kg load, with both 52100 and 440C steel balls were analyzed and compared with untested fluids. Infrared spectra of both formulated and unformulated Apiezon C, with both 52100 and 440C steel balls, showed only increased amounts of lower molecular weight hydrocarbon material when tested at 75°C (167°F) (Figure 15). Samples tested at 200°C (390°F), however, exhibited peaks attributable to carbonyl groups, suggesting the possibility of a temperature dependent formation of carboxylic acids in those samples (Figure 16). In addition, the neutralization number indicated that greater amounts of acid are formed with 440C balls than with 52100 balls and that formulated Apiezon C has a significantly higher acid number than non-formulated Apiezon C. Because of the great similarity between the formulated Apiezon C used in the four-ball testing and the Apiezon A based lubricant used in the present study, it was hoped that infrared analysis would again provide useful information, and indeed it did. As can be seen in Figure 16, both the oil samples recovered from the races and retainer of the forward bearing gave infrared spectra containing carbonyl peaks, at least one of

APIEZON 'C' (VIRGIN)

FORMULATED APIEZON 'C' (VIRGIN)

FORMULATED APIEZON 'C' STRESSED AT 167°F

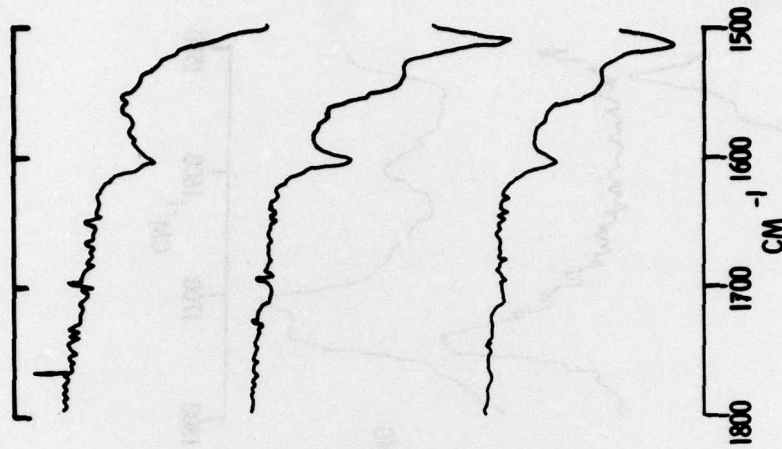

Figure 15. Partial Infrared Spectra for Apiezon C, Formulated Apiezon C, and Formulated Apiezon C Stressed at 167°F



FORMULATED APIEZON 'C' STRESSED AT 390°F

OIL RECOVERED FROM RACES OF FORWARD BEARING

OIL RECOVERED FROM RETAINER OF FORWARD BEARING

Figure 16. Partial Infrared Spectra for Formulated Apiezon C Stressed at 390°F and the Oil Recovered from the Races and Retainer of the Forward Bearing

which was at the same absorption, 1710 cm^{-1} , as in formulated Apiezon C stressed at 390°F . Similar infrared absorptions were absent in both formulated and unformulated Apiezon C, thus confirming that the lubricant underwent (thermal) degradation during the accelerated life test.

SECTION V

CONCLUSIONS

There are several conclusions which may be drawn from the test and bearing failure analyses. Perhaps the most significant of these is that premature test termination was due to a seizure of the bearing caused by instability and wear of the retainer to the point that it became wedged against the outer race land by the balls, with a breakaway torque in excess of that available. Other than that presented in Figure 14, no metrology data, as such, were obtained on these bearings, nor was the eccentricity of the races or retainer checked specifically. Similar bearings, for example S/N 29, not used in this test have been examined, however, and appear to be of high quality (Reference 4, Bearing E). For example, the radial deviation from roundness of the outer and inner races of S/N 29 is $0.63 \mu\text{m}$ ($25 \mu\text{in.}$) and $1.25 \mu\text{m}$ ($50 \mu\text{in.}$), respectively. In contrast, the relatively poor quality of cotton phenolic retainers in general (Reference 3) as well as their eccentricity and instability when tested under the DMA operating conditions of 60 rpm and light loads is well documented (References 5 and 6). It seems reasonable to conclude, therefore, that the greatest part of the responsibility for having caused this "failure" must be borne by the cotton phenolic retainer; not only because of its characteristic instability and its role as a major debris generator, but also because of its inherent inability to provide adequate lubrication at the critical retainer-outer race land interface. An obvious conclusion, therefore, is that an outer land riding separator may not be the optimum design for successful long-term vacuum operation. It

can also be stated that wear of metallic components is not a problem, even under these accelerated conditions. In addition, while the ball track appeared to contain ample amounts of lubricant, the evidence of chemical degradation of this material raises a question as to its long-term performance capability and dictates a need for increased emphasis on the development of improved lubricants for extended life missions.

This report has attempted to describe the careful analyses needed to uncover the causative factors in satellite bearing failures. In this case, it appears that the retainer was at fault, reinforcing the need for a comprehensive program to examine retainer behavior and qualify improved materials for this critical component. It should be remembered that only in ground testing do we have the "luxury" of examining failed bearings; in a malfunctioning operational vehicle, one can only speculate as to the cause. Finally, lest it be thought that the accelerated test described herein was not necessarily representative of the operational environment, it should be pointed out that at the same time this failure analysis was underway, an operational Defense Satellite Communications Systems (DSCS) vehicle was tumbling out of control in space because the bearings had ceased to operate.

REFERENCES

1. R. J. Benzing and J. R. Strang, Failure Mode Analyses of Lubricated Satellite Components, AFML-TR-73-188, May 1974.
2. J. C. Tyler, H. J. Carper, R. D. Brown, and P. M. Ku, Analyses of Film Thickness Effect in Slow-Speed Lightly Loaded Elastohydrodynamic Contacts, AFML-TR-74-189, Part I, December 1974; Part II, January 1976; Part III, March 1977.
3. W. E. Ward, "Preparation of DMA Bearing for Accelerated Life Prediction Studies," Lubrication Engineering, 35, 17 (1978).
4. W. E. Ward, The Preparation of 90mm and 100mm Bore Bearings for Performance Evaluation in a Simulated Space Environment, AFML-TR-78-17, July 1978.
5. J. W. Kannel and S. S. Bupara, "A Simplified Model of Cage Motion in Angular Contact Bearings Operating in the EHD Regime," ASME Paper No. 77-LUB-16, ASLE-ASME Lubrication Conference, Kansas City, MO, 3-5 October 1977.
6. J. W. Kannel, S. S. Bupara, and C. D. Pentlicki, Investigation of Cage and Bearing Instability in Despin Antenna Bearings Due to Changes in Lubricant Properties, AFML-TR-75-38, Part I, April 1975; Part II, April 1976.