

AD-A074 558

OHIO STATE UNIV COLUMBUS ELECTROSCIENCE LAB
COMMUNICATION APPLICATION OF ADAPTIVE ARRAYS.(U)
JUN 79 R T COMPTON

F/G 17/2

N00019-79-C-0291

UNCLASSIFIED

ESL-711847-1

NL

| OF |
AD
A074558



END
DATE
FILMED
11-79
DDC

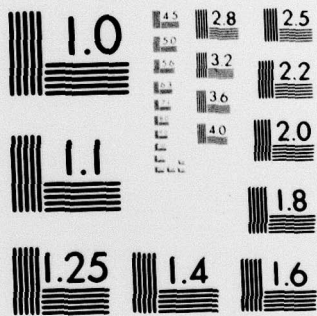

MICROCOPY RESOLUTION TEST CHART
 NATIONAL BUREAU OF STANDARDS-1963-A

LEVEL *IT*

OSU

COMMUNICATION APPLICATION OF ADAPTIVE ARRAYS

R.T. Compton, Jr.

The Ohio State University

12
SC

AD A 0 7 4 5 5 8

The Ohio State University

ElectroScience Laboratory

Department of Electrical Engineering
Columbus, Ohio 43212

Quarterly Report 711847-1

June 1979

APPROVED FOR PUBLIC RELEASE
DISTRIBUTION UNLIMITED

DDC FILE COPY

DDC
OCT 2 1979
A

Naval Air Systems Command
Washington, D.C. 20361

79-10401-037

NOTICES

When Government drawings, specifications, or other data are used for any purpose other than in connection with a definitely related Government procurement operation, the United States Government thereby incurs no responsibility nor any obligation whatsoever, and the fact that the Government may have formulated, furnished, or in any way supplied the said drawings, specifications, or other data, is not to be regarded by implication or otherwise as in any manner licensing the holder or any other person or corporation, or conveying any rights or permission to manufacture, use, or sell any patented invention that may in any way be related thereto.

UNCLASSIFIED

SECURITY CLASSIFICATION OF THIS PAGE (When Data Entered)

REPORT DOCUMENTATION PAGE		READ INSTRUCTIONS BEFORE COMPLETING FORM
1. REPORT NUMBER	2. GOVT ACCESSION NO.	3. RECIPIENT'S CATALOG NUMBER
4. TITLE (and Subtitle) 6 COMMUNICATION APPLICATION OF ADAPTIVE ARRAYS		5. TYPE OF REPORT & PERIOD COVERED 9 Quarterly Report
7. AUTHOR(s) 10 R.T. Compton, Jr.		6. PERFORMING ORG. REPORT NUMBER 14 ESL-711847-1
9. PERFORMING ORGANIZATION NAME AND ADDRESS The Ohio State University ElectroScience Laboratory, Department of Electrical Engineering Columbus, Ohio 43212		8. CONTRACT OR GRANT NUMBER(s) 15 N00019-79-C-0291
11. CONTROLLING OFFICE NAME AND ADDRESS Naval Air Systems Command Washington, D.C. 20361		10. PROGRAM ELEMENT, PROJECT, TASK AREA & WORK UNIT NUMBERS
14. MONITORING AGENCY NAME & ADDRESS (if different from Controlling Office) 12 7		12. REPORT DATE Jun 79
		13. NUMBER OF PAGES
		15. SECURITY CLASS. (of this report) Unclassified
		15a. DECLASSIFICATION/DOWNGRADING SCHEDULE
16. DISTRIBUTION STATEMENT (of this Report) APPROVED FOR PUBLIC RELEASE DISTRIBUTION UNLIMITED		
17. DISTRIBUTION STATEMENT (of the abstract entered in Block 20, if different from Report)		
18. SUPPLEMENTARY NOTES		
19. KEY WORDS (Continue on reverse side if necessary and identify by block number) Antennas Adaptive arrays Interference		
20. ABSTRACT (Continue on reverse side if necessary and identify by block number) This report describes progress under Naval Air Systems Command Contract N00019-79-C-0291 during the first quarterly period. Research on adaptive arrays for communication applications is sum- marized.		

402 257

TABLE OF CONTENTS

	Page
I. INTRODUCTION	1
II. PROGRESS	1
A. <u>The Improved LMS Loop</u>	1
B. <u>Reference Signal Generation with FSK Signals</u>	1
C. <u>Adaptive Array Monograph</u>	3
REFERENCE	3

Accession For	
NTIS GRA&I	<input checked="" type="checkbox"/>
DDC TAB	<input type="checkbox"/>
Unannounced	
Justification	
By _____	
Distribution/	
Availability Codes	
Dist.	Avail and/or special
A	

I. INTRODUCTION

This report describes progress under NASC Contract N00019-79-C-0291 during the first quarterly period. There are three areas of work under this contract. The first involves studies on weight jitter and dynamic range for the improved LMS loop. The second is a continuation of research on a reference signal generation technique for FSK signals. The third area involves the preparation of a monograph on adaptive arrays.

II. PROGRESS

A. The Improved LMS Loop

Under the previous contract, a modified form of the LMS loop was found that solves the problem of time constant spread [1]. This new loop includes an averaging operation, originally defined as a finite time average. However, a finite time average is inconvenient to implement, and it would be preferable to use a simple lowpass filter instead.

During this quarter, studies and computer simulations have been done on the modified loop using a simple RC lowpass filter instead of the finite time average. The results show that this change can be made without substantially changing the performance of the system. With the lowpass filter in the loop, the differential equations for the weights are 2nd order, instead of 1st order as with the finite time average. Each weight transient includes two exponential terms, one due to each pole of the differential equation. We find that as the signal power is varied, one pole has a fixed position in the complex frequency plane, and the other moves. The stationary pole yields the desired fixed time constant term in the weight response. The moving pole contributes a term whose time constant depends on signal power, but the amplitude of this term is extremely small compared to that of the fixed pole. As a result, this term contributes only negligibly to the weight transients. The weight transients thus have the desired behavior with the RC filter.

Work on the modified LMS loop is continuing with studies on weight jitter.

B. Reference Signal Generation with FSK Signals

Studies on the use of FSK signals with adaptive arrays have been continued. Recent work involves the acquisition behavior of the adaptive array with a reference signal generation loop. The FSK signal is assumed to be from a first-order Markov source with known transition probabilities. This assumption allows each bit to be predicted from the last bit, with a better-than-average probability of success. The array output is processed in a loop, as shown in Fig. 1, to produce the reference signal. In this loop, during each bit interval, the oscillator is keyed so that the predicted frequency of the desired signal is shifted to the center of the bandpass filter. The second mixer then shifts the filter output signal

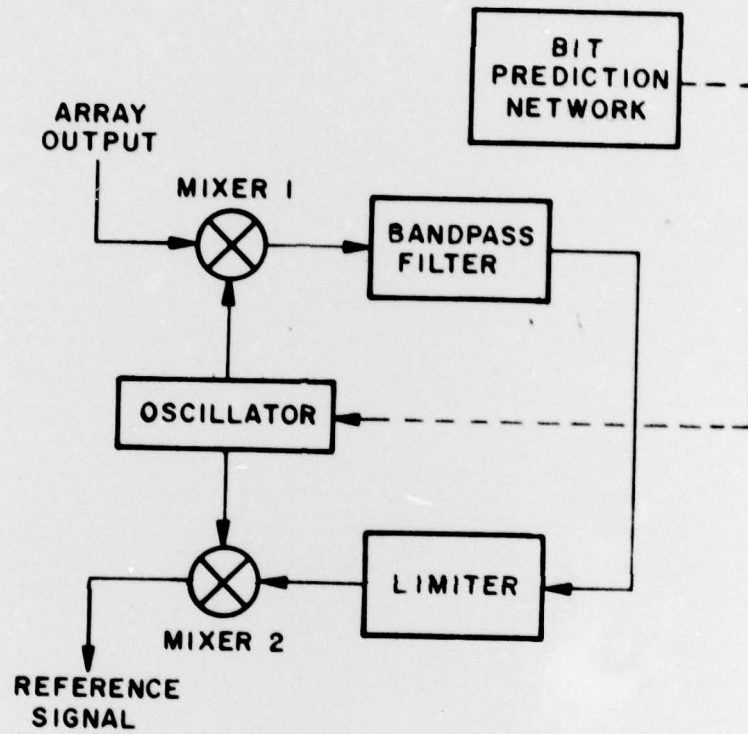

Fig. 1. The FSK Reference Signal Loop.

back to the original frequency where it becomes the reference signal. The limiter controls the level of the reference signal.

Computer simulations are being done for a two-element LMS array combined with this reference signal processing loop. The input to the array includes an FSK desired signal, interference, and thermal noise. Most simulations to date have assumed a large CW interference signal directly on one of the two FSK frequencies. The program computes the reference signal transients, the weight transients, and the antenna patterns.

These simulations are being done, along with theoretical analyses, to study the relationship between the reference loop parameters and the array lockup characteristics. The effects of prediction probability, filter characteristics, spurious frequencies (filter leak-through and mixer products) and limiter characteristics are being evaluated.

C. Adaptive Array Monograph

An introductory chapter on adaptive array feedback algorithms is currently being written. This chapter presents the feedback algorithms of Shor, Widrow, Applebaum, Griffiths and Frost in a unified manner, and also discusses methods for overcoming eigenvalue spread--Sample Matrix Inversion, Baird's technique, the improved LMS loop, and schemes related to a Gram-Schmidt orthogonalization procedure. A discussion of several other approaches, such as random search, phase-only control, and power optimization will also be included.

REFERENCE

- [1] R.T. Compton, Jr., "An Improved Feedback Loop for Adaptive Arrays," Report 710929-3, July 1978, The Ohio State University Electro-Science Laboratory, Department of Electrical Engineering; prepared under Contract N00019-78-C-0131 for Naval Air Systems Command.