

AD-A074 609

DAVID W TAYLOR NAVAL SHIP RESEARCH AND DEVELOPMENT CE--ETC F/6 13/10  
SENSOR REQUIREMENTS AND AVAILABILITY FOR SHIP-BOARD AUXILIARY M--ETC(U)  
SEP 79 H K WHITESEL

UNCLASSIFIED

DTNSRDC/PAS-79-14

NL

| OF |  
ADA  
074609



END  
DATE  
FILMED  
10 -79  
DDC

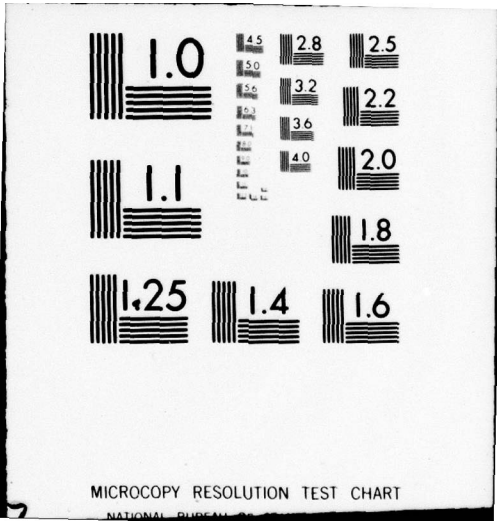

MICROCOPY RESOLUTION TEST CHART

NATIONAL BUREAU OF STANDARDS-1963-A

**LEVEL**

**12** B.S.

**DAVID W. TAYLOR NAVAL SHIP  
RESEARCH AND DEVELOPMENT CENTER**

Bethesda, Maryland 20084



DTNSRDC/PAS-79-14

**AD A U 7 4 6 0 9**

**SENSOR REQUIREMENTS AND AVAILABILITY FOR SHIPBOARD  
AUXILIARY MACHINERY, PHASE I - RANGE  
AND ACCURACY**

By

Henry K. Whitesel

**DDC  
RECEIVED  
OCT 5 1979  
E**

SENSOR REQUIREMENTS AND AVAILABILITY FOR SHIPBOARD  
AUXILIARY MACHINERY, PHASE I - RANGE AND ACCURACY

**DDC FILE COPY**

APPROVED FOR PUBLIC RELEASE: DISTRIBUTION UNLIMITED.

AUXILIARY AND PROPULSIONS SYSTEMS DEPARTMENT

RESEARCH AND DEVELOPMENT REPORT

**79 09 26 054**

September 1979

DTNSRDC/PAS-79-14

## MAJOR DTNSRDC ORGANIZATIONAL COMPONENTS

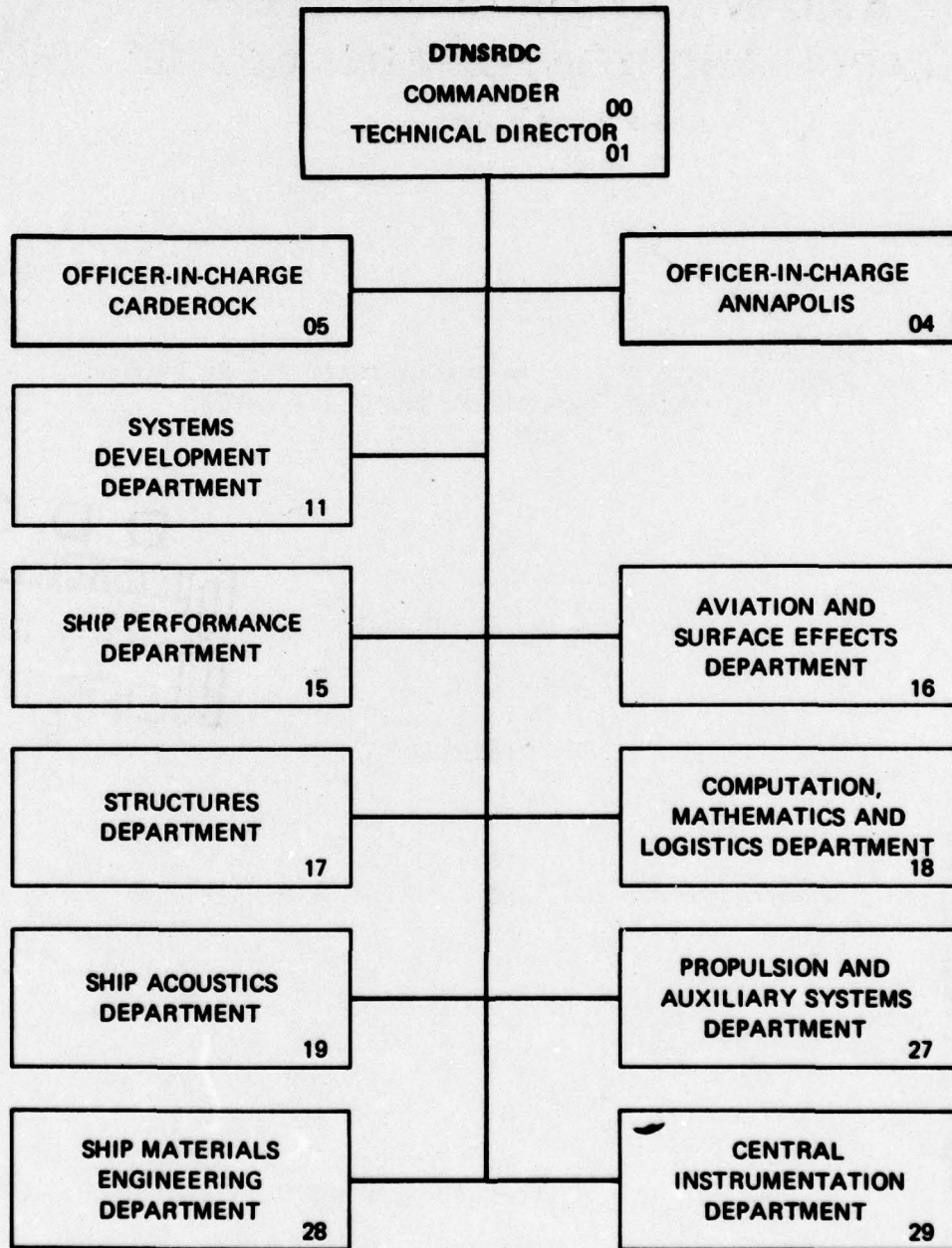

UNCLASSIFIED

SECURITY CLASSIFICATION OF THIS PAGE (When Data Entered)

REPORT DOCUMENTATION PAGE

READ INSTRUCTIONS BEFORE COMPLETING FORM

1. REPORT NUMBER <b>14</b> DTNSRDC/PAS-79-14 ✓	2. GOVT ACCESSION NO.	3. RECIPIENT'S CATALOG NUMBER
4. TITLE (and Subtitle) <b>6</b> SENSOR REQUIREMENTS AND AVAILABILITY FOR SHIPBOARD AUXILIARY MACHINERY, PHASE I RANGE AND ACCURACY.		5. TYPE OF REPORT & PERIOD COVERED
7. AUTHOR(s) <b>10</b> Henry K. Whitesel		6. PERFORMING ORG. REPORT NUMBER
9. PERFORMING ORGANIZATION NAME AND ADDRESS David W. Taylor Naval Ship R&D Center ✓ Annapolis, MD 21402		8. CONTRACT OR GRANT NUMBER(s)
11. CONTROLLING OFFICE NAME AND ADDRESS David W. Taylor Naval Ship R&D Center Bethesda, MD 20084		10. PROGRAM ELEMENT, PROJECT, TASK AREA & WORK UNIT NUMBERS See other side
14. MONITORING AGENCY NAME & ADDRESS (if different from Controlling Office) <b>16</b> F43433, S0359 <b>17</b> SF43433342, S0359701		12. REPORT DATE <b>11</b> September 1979
		13. NUMBER OF PAGES 30
		15. SECURITY CLASS. (of this report) Unclassified <b>12</b> 351
		15a. DECLASSIFICATION/DOWNGRADING SCHEDULE

**9** Research and development rept.

16. DISTRIBUTION STATEMENT (of this Report)  
APPROVED FOR PUBLIC: DISTRIBUTION UNLIMITED.

17. DISTRIBUTION STATEMENT (of the abstract entered in Block 20, if different from Report)

18. SUPPLEMENTARY NOTES

19. KEY WORDS (Continue on reverse side if necessary and identify by block number)  
Sensors  
Transducers  
Machinery monitoring  
Shipboard machinery monitoring requirements

20. ABSTRACT (Continue on reverse side if necessary and identify by block number)  
→ The requirements and availability of sensors for the Shipboard Machinery Performance Monitoring Program are discussed in terms of accuracy and range. Sensor requirements for the Shipboard Machinery Performance Monitoring Program are given. Pressure, temperature, and flow sensors are tabulated in terms of industrial availability and qualifications to shipboard military specifications. ↙

79 09 26 054

**UNCLASSIFIED**

**SECURITY CLASSIFICATION OF THIS PAGE(When Data Entered)**

Item 10

Program Element 62543N, Task Area SF 43-433-302, Work Unit 1-2730-100 and  
Program Elenent 63585N, Task Area S0359 001, Work Unit 1-2731-141.

TABLE OF CONTENTS

	Page
FIGURE . . . . .	iii
LIST OF TABLES . . . . .	iii
LIST OF ABBREVIATIONS . . . . .	iv
ABSTRACT . . . . .	1
ADMINISTRATIVE INFORMATION . . . . .	1
INTRODUCTION . . . . .	1
PURPOSE AND SCOPE . . . . .	1
BACKGROUND . . . . .	1
DEFINITION OF TERMS . . . . .	2
ORGANIZATION OF INFORMATION . . . . .	4
SMPMP SENSOR REQUIREMENTS . . . . .	5
ENVIRONMENT . . . . .	5
MACHINERY SYSTEMS . . . . .	6
MACHINERY COMPONENTS . . . . .	7
SENSORS REQUIRED . . . . .	8
MILITARY SPECIFIED SENSORS . . . . .	14
MILITARY QUALIFIED AND INDUSTRIAL OFF-THE-SHELF SENSORS . . . . .	16
CONCLUSIONS . . . . .	20
COMMENTS . . . . .	21
FUTURE WORK . . . . .	22
ACKNOWLEDGMENTS . . . . .	23
REFERENCES . . . . .	25

Figure 1 - Sensor Definition . . . . .	2
--	---

LIST OF TABLES

1 - Sensors Required for the Shipboard Machinery Performance Monitoring System . . . . .	8
2 - Summary of Naval Shipboard Military Specifications Potentially Useful for SMPMP Sensors . . . . .	14
3 - Range and Accuracy Requirements for Military Specified Shipboard Sensors . . . . .	15
4 - Range and Accuracy of Military Qualified and Commercially Available Sensors for the SMPMP . . . . .	17

## LIST OF ABBREVIATIONS

A	Amperes
Btu/hr/ft <sup>2</sup> /°F	British Thermal Unit per hour per square foot per degree Fahrenheit
cc/hr	Cubic centimeters per hour
DTNSRDC	David W. Taylor Naval Ship R&D Center
°C	Degree Celsius
°F	Degree Fahrenheit
EMP	Equivalent parts per million
FS	Full scale
ft	Foot
ft/sec	Feet per second
ft <sup>2</sup> /sec	Square feet per second
g	Gravity acceleration units
gpm	Gallons per minute
hp	Horsepower
Hz	Hertz
in.	inch
in. Hg(a/g)	Inches of mercury (absolute or gage)
kHz	Kilohertz
Klb	Thousand pounds
kW	Kilowatt
lb-ft	Pound-feet
MHz	Megahertz
mm	Millimeter
mW	Megawatt
ppm	Parts per million
psi	Pounds per square inch
psia/g	Pounds per square inch absolute/gage
psid	Pounds per square inch differential
QPL	Qualified Products List
RTE	Resistance temperature element
SEB	Static error band
sec	Second
SMPMP	Ship Machinery Performance Monitoring Program

LIST OF ABBREVIATIONS (Continued)

V Volt  
 Vac Volt alternating current  
 Vdc Volt direct current  
 rpm Revolutions per minute  
 WCD Water column differential  
 H<sub>2</sub>O Water  
 Hg Mercury  
 μ Micro  
 μin./in. Microinch per inch  
 % rdg Percent of reading

Accession For	
NTIS GRA&I	
DCC TAB	
Unannounced	
Justification <input checked="" type="checkbox"/>	
By _____	
Distribution/	
Availability Codes	
Dist	Avail and/or special
A	

## ABSTRACT

The requirements and availability of sensors for the Shipboard Machinery Performance Monitoring Program are discussed in terms of accuracy and range. Sensor requirements for the Shipboard Machinery Performance Monitoring Program are given. Pressure, temperature, and flow sensors are tabulated in terms of industrial availability and qualifications to shipboard military specifications.

## ADMINISTRATIVE INFORMATION

This report completed one milestone of the Shipboard Machinery and Control - Monitoring and Automation Project, Task B, funded under Program Element 62543N, Task Area SF 43-433-302, Work Unit 1-2730-100 and Program Element 63585N, Task Area S0359 001, Work Unit 1-2731-141.

## INTRODUCTION

### PURPOSE AND SCOPE

This report is a preliminary statement of the Navy shipboard requirements for and availability of sensors for use by the SMPMP.\* Requirements are specifically aimed at machinery used on new construction surface ships. Sensor performance characteristics discussed here are limited to range and accuracy. A second report on this subject will describe sensors performance in more complete detail.

### BACKGROUND

The existing methodology by which the Navy maintains shipboard auxiliary machinery includes planned maintenance actions done on a regular basis according to the calendar. Open-and-inspect procedures and regular overhaul of equipment are typical methods.

There are several reasons why the Navy has become interested in machinery "health" monitoring programs. The rising cost of manpower makes it cost effective to provide automatic machinery fault diagnosis including the use of trending analysis and maintenance prediction techniques. The recent advancement of automatic test equipment technology has made it possible to develop and implement machinery "health" monitoring programs.

---

\*Definitions of abbreviations appear on page iv.

In response to the needs and capabilities, the SMPMP was established to provide the following information for surface ship machinery:

1. Machinery operational status.
2. Machinery maintenance requirements.

Benefits derived from the successful completion of the SMPMP are expected to be: a reduction of forced outages, reduced operating costs, ability to ascertain energy utilization and savings to promote overall systems safety, reduced maintenance costs, maintenance performed on demand, improved reporting of machinery history, extended machinery life, and improved machinery systems operational readiness.

#### DEFINITION OF TERMS

Figure 1 illustrates the definition of a sensor and includes relationships of several other terms defined in the following sections and used in this report. In general, the terminology conforms to or is similar to that prepared by the Instrument Society of America Subcommittee SP37. The definitions that follow are listed in alphabetical order.

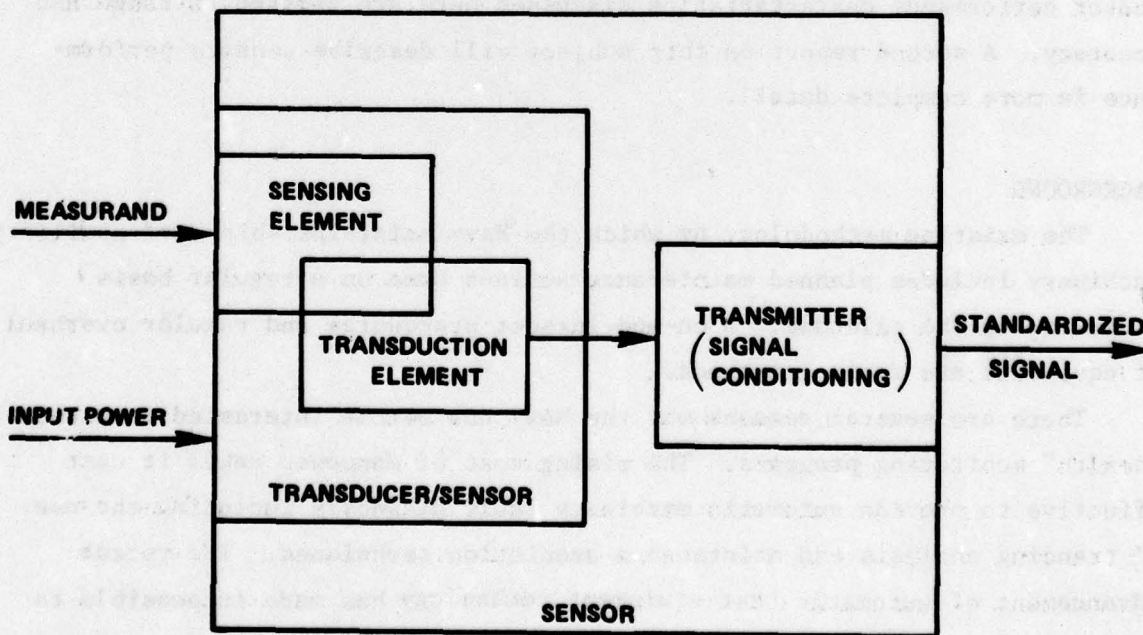

Figure 1 - Sensor Definition

### Accuracy

The ratio of the error to the full-scale output or the ratio of the error to the actual output, as specified, expressed in percent.

Note 1: Accuracy may also be expressed in terms of units of measurand.

Note 2: Use of the term "accuracy" should be limited to generalized descriptions of characteristics. The term "error" is preferred in specifications and other specific descriptions of transducer performance.

### First Article Tests

A set of tests, given in the quality assurance provisions section of some military specifications, usually applied to the first model of a production contract.

Note 1: "First article tests" are similar to qualification tests but a sensor is not "qualified" after successfully passing "first article tests." A sensor is "qualified" only after passing specified qualification tests and being placed on the qualified products list (QPL) associated with the particular military specification.

Note 2: On production contracts for sensors that meet requirements of military specifications which have associated QPL's, contract award is usually made only for equipment that is listed on the QPL. Those military specifications that do not have associated QPL's require "first article tests." A contract based on such a specification will require "first article tests." However, the tests may be waived if it is determined that the sensors to be provided have previously passed "first article tests."

### Measurand

A physical quantity property or condition which is measured, expressed in a percent of the output reading.

### Qualified

A sensor is "qualified" if it has successfully passed specified qualification tests and has been placed on the QPL. (See first article tests.)

### Range

The measurand values, over which a transducer is intended to measure, specified by their upper and lower limits, (operating range).

### Sensing Element

That part of the transducer which responds directly to the measurand.

### Sensor

A device that responds to a physical stimulus (as heat, light, sound, pressure, magnetism, or a particular motion) and transmits a resulting signal (as for measurement or operating a control).

Note: Sensor is also a general term that is commonly used to mean one or some combination of sensing element, transduction element, transducer, and transmitter. (See Figure 1.)

### Static Error Band

The maximum deviation from a straight line drawn through the coordinates of the lower span limit at specified transducer output and the upper span limit at specified transducer output expressed in percent of transducer range.

### Transducer

An element or device which receives information in one form and converts it to information in another form.

### Transduction Element

The element or device used to convert information obtained by the sensing element into a form suitable for measurement and/or transmission.

### Transmitter

A device which responds to the output of a transducer or sensor and generates a standardized transmission signal which is a function only of the measurand.

Note: Transmitter is sometimes used to also include the sensing element and the transduction element.

## ORGANIZATION OF INFORMATION

Sensor information for the SMPMP is organized in the following categories:

1. SMPMP Sensor Requirements. An estimate of the sensor types, ranges, and accuracies required for the SMPMP to monitor shipboard auxiliary machinery using inputs from both the Naval Ship Engineering Center, Philadelphia Division<sup>1\*</sup> and this Center.

---

\*A complete listing of references appears on page 25.

2. Military Qualified Sensors. A list of those sensors, available off-the-shelf and already tested and/or qualified for use in the shipboard environment.

3. Industrial Sensors. A list of those sensors, available off-the-shelf for industrial use, which are not presently qualified for shipboard use, but which could be with the expenditure of additional effort.

The sensor tables presented here (Tables 1 through 4) were compiled from literature searches, technical brochures, reviews of articles, and research laboratory communications.

Another class of sensors, which are not discussed in this report but which must be considered for use by the SMPMP are the laboratory available sensors. These are a group of sensors developed by both private and government sources for a particular, small quantity, need for which an off-the-shelf product line cannot be justified. Also included in this category of sensors are those which are presently in development (perhaps for a predicted market) that can be expected to be available prior to completion of the SMPMP. The laboratory available sensors include the most advanced sensor technology available.

#### SMPMP SENSOR REQUIREMENTS

A complete description of the sensors required for the SMPMP cannot be given at this time. As a start on describing the sensor problem, this section discusses the operating environment, types of sensors, and accuracy and resolution required.

#### ENVIRONMENT

There are several environmental factors to be considered when procuring sensors for use in the shipboard machinery spaces. Four of the more important ones are: vibration, shock, temperature, and humidity.

Shipboard vibration conditions and tests are specified in MIL-STD-167.<sup>2</sup> Shock and vibration mountings will be allowed only on an individual basis. The design requirement for most sensors shall be to withstand the Type I tests (environmental vibration) of MIL-STD-167.

Shipboard shock conditions and tests are specified in MIL-S-901.<sup>3</sup> The design requirement for most sensors will be to satisfy high impact

shock requirements for Grade A items (machinery, systems, and equipment), Class I equipment, Type C tests of MIL-S-901.<sup>3</sup>

Shipboard temperature and humidity conditions and tests are specified in MIL-I-983.<sup>4</sup> Ambient external air operating temperature limits are 4° to 65° C (40° to 149° F) with relative humidity of 95 percent or more without exceeding an external enclosure or an internal air temperature of 115° C (239° F).<sup>4</sup> The temperature rise above any ambient external air temperature shall not exceed 50° C (90° F). Storage temperature extremes shall be within the limits of -40° to 75° C (-40° to 167° F).<sup>4</sup>

The description of the shipboard environment, given above, is intended only for general use as a guide to prospective sensor suppliers. A precise environmental description can only be stated after the particular shipboard machinery system, component, parameter to be sensed, and mounting location of the sensor is established.

#### MACHINERY SYSTEMS

The SMPMP is intended for new construction surface ships. The particular shipboard machinery systems being considered for monitoring include:

1. Controllable reversible pitch propeller.
2. Ship's service diesel engine.
3. Anchor windlass
4. Fuel oil service
5. Lube oil service.
6. Seawater cooling.
7. Distilling plant.
8. Main reduction gear.
9. Main propulsion overrunning clutch.
10. Couplings and line shaft bearings.
11. Ship's service diesel generator.
12. Power supplies.
13. Bus transfer, auto.
14. Switchboards and distribution (cables).
15. Frequency changer.
16. Transformers, 60 and 400 hertz.
17. Batteries and service facilities.

18. Voltage regulator.
19. Motors of auxiliary equipment (25-hp and over).
20. Air-conditioning system.
21. Compartment heating system.
22. Tank level indicating system.
23. Laundry equipment.

#### MACHINERY COMPONENTS

The machinery components that make up the machinery systems likely to be monitored for the SMPMP include, but are not limited to:

1. Diesel engines.
2. Diesel generators.
3. Compressors.
4. Air blowers.
5. Electric motors.
6. Electrical generators.
7. Wiring and cables.
8. Voltage regulators.
9. Relays.
10. Switches.
11. Transformers.
12. Pumps.
13. Pipes.
14. Valves.
15. Couplings.
16. Bushings.
17. Condensers (heat exchangers).
18. Tanks.
19. Gears.
20. Bearings.
21. Brakes.
22. Clutches.
23. Shafts.
24. Propellers.

## SENSORS REQUIRED

An estimate of the type of sensors required for SMPMP is given in Table 1. Types of sensors required were compiled from a NAVSECPHILADIV document. Quantitative estimates of the range and accuracy were made by this Center. This list will be revised prior to issue of the second report. Inputs concerning the sensor list are welcomed.

TABLE 1 - SENSORS REQUIRED FOR THE SHIPBOARD  
MACHINERY PERFORMANCE MONITORING SYSTEM

Sensor	Ranges	Accuracies
Pressure (gage, absolute, and differential)	0-1 psid	<u>+1%</u> FS
	0-10 psid	<u>+1%</u> FS
	0-50 psid	-
	0-200 in. of H <sub>2</sub> O (d)	<u>+1</u> in.
	0-0.5 psig	-
	0-1 psig	<u>+1%</u> to <u>+10%</u> FS
	0-15 psig	<u>+1%</u> to <u>+10%</u> FS
	20-40 psig	<u>+0.5</u> psi
	0-50 psig	<u>+0.5</u> psi
	0-100 psig	<u>+1%</u> to <u>+10%</u> FS
	75-100 psig	<u>+1.0</u> psi
	120-140 psig	<u>+1.0</u> psi
	0-150 psig	<u>+1%</u> to <u>+10%</u> FS
	0-300 psig	<u>+1%</u> to <u>+10%</u> FS
	0-3000 psig	<u>+1%</u> to <u>+10%</u> FS
	5-20 psia	-
	15-20 psia	-
	0-25 psia	-
	15-55 psia	-
	15-300 psia	-
22-32 inches of Hg	-	
0-80 inches of Hg	-	

TABLE 1 (Continued)

Sensor	Ranges	Accuracies
Concentration meters (oil in water, water in oil, particles in oil)	1-20%	<u>+1%</u>
	0-100 ppm	<u>+10 ppm</u>
	0-10 ppm	<u>+5 ppm</u>
	10 $\mu\text{m}$ -300 $\mu\text{m}$	<u>+1 <math>\mu\text{m}</math></u>
Temperature	40° to 50° F	<u>+0.2° F</u>
	50° to 80° F	<u>+1° F</u>
	40° to 85° F	<u>+0.3° F</u>
	20° to 110° F	<u>+0.5° F</u>
	0° to 120° F	<u>+0.2% FS</u>
	-20° to 130° F	-
	-40° to 140° F	-
	140° to 170° F	<u>+1° F</u>
	0° to 200° F	<u>+1% FS</u>
	0° to 300° F	<u>+1° F</u>
	-20° to 300° F	-
	300° to 600° F	-
	-20° to 1000° F	-
0° to 1500° F	-	
-20° to 1600° F	-	
Voltage, continuous	-17 Vdc	<u>+3 V</u>
	14-20 Vdc	<u>+0.1 V</u>
	0-20 Vdc	-
	0-125 Vdc	-
	0-125 Vac	-
	410-470 Vac	-
	100-130 Vac	-
	435-445 Vac	-
	113-117 Vac	-
	437-442 Vac	-
114-116 Vac	-	

TABLE 1 - (Continued)

Sensor	Range	Accuracies
Current, electrical	0-100 A	<u>+1</u> A
	0-500 A	<u>+1</u> A
	0-1500 A	<u>+3</u> A
Resistance	0-1 ohm	-
	0-10 ohm	-
	1-10 megohm	-
	10-100 megohm	-
	100-1000 megohm	-
	1000-10,000 megohm	-
	10,000-100,000 megohm	-
Noise and vibration (including acoustic emission)	0-100 g, 0-200 kHz	<u>+1</u> g
	0-100 g, 0-100 kHz	<u>+1</u> g
	0-100 g, 0-40 kHz	<u>+1</u> g
	0-100 g, 0-10 kHz	<u>+1</u> g
	0-20 g, 0-200 kHz	<u>+0.2</u> g
	0-20 g, 0-100 kHz	<u>+0.2</u> g
	0-20 g, 0-40 kHz	<u>+0.2</u> g
	0-20 g, 0-10 kHz	<u>+0.2</u> g
	40-100 kHz	-
	100-2 mHz	-
Flow rate	7.5-96 gpm	-
	0-140 gpm	<u>+0.1</u> gpm or <u>+1%</u> reading
	0-200 gpm	<u>+0.2</u> gpm or <u>+1%</u> reading
	100-400 gpm	<u>+10</u> gpm
	0-1200 gpm	<u>+1</u> gpm or <u>+1%</u> reading
	0-10 pounds (mass)	<u>+3%</u> FS
Transients, voltage amplitude, and voltage spikes	350-530 Vac	-
	80-140 Vac	-
	0-2500 V (peak)	-

TABLE 1 (Continued)

Sensor	Range	Accuracies
Frequency, electrical	55-65 Hz	-
	375-425 Hz	-
	58-62 Hz	-
	385-415 Hz	-
	59-60 Hz	-
	395-405 Hz	-
	59.5-60.5 Hz	-
	397-403 Hz	-
Harmonic distortion (on electrical supply)	0-3%	-
	0-5%	-
	0-6%	-
Power, electrical	0-100 kW	-
	0-150 kW	+2% of reading
	0-80 mW	-
Percent voltage modulation (on electrical supply)	0-2%	-
	0-1%	-
Viscosity, kinematic	$3 \times 10^{-6} - 2 \times 10^{-5}$ ft <sup>2</sup> /sec	$\pm 1 \times 10^{-6}$ ft <sup>2</sup> /sec
	$1 \times 10^{-5} - 1 \times 10^{-4}$ ft <sup>2</sup> /sec	$\pm 2 \times 10^{-6}$ ft <sup>2</sup> /sec
	$1 \times 10^{-4} - 4 \times 10^{-3}$ ft <sup>2</sup> /sec	$\pm 4 \times 10^{-5}$ ft <sup>2</sup> /sec
Specific gravity	0.5-1.1	+5% reading
	0.99950-1.00000	$5 \times 10^{-5}$
	0.999950-1.000000	$5 \times 10^{-6}$
Density	0-3	+10%
Wear	0-5 mm	+1% FS
	0-10 mm	+0.5 mm
Liquid level (oil, water, freon)	0-1 inch	+0.1 inch
	0-10	+1.0 inch
	0-12 inch	+10% FS
	0-20 inch	+1.0 inch
	0-30 ft	+1 ft

TABLE 1 (Continued)

Sensor	Range	Accuracies	
Torque	0-100 lb-ft	<u>+0.5 lb-ft</u>	
	0-2000 lb-ft	-	
	0-2,000,000 lb-ft	-	
Heat transfer	0-500 Btu/hr/ft <sup>2</sup> /°F	<u>+2% reading</u>	
Leaks	Steam	<u>+5% reading</u>	
		75-12,500 cc/hr	<u>+5% reading</u>
	Water	0-10,000 cc/hr	<u>+5% reading</u>
	Air/gas	75-30,000 cc/hr	<u>+5% reading</u>
	Hydraulic oil	0-100 cc/hr	<u>+5% reading</u>
Load	0-10 Klb	<u>+1% FS</u>	
Proximity (gear teeth passing top dead center)	0.025-0.125 inch at 0-50 kHz	-	
	0-050-0.250 inch at 0-50 kHz	-	
Position (linear)	0-10 mm	<u>+0.5 mm</u>	
	0-0.05 inch	<u>+1% FS</u>	
	0-2 inch	<u>+0.1 inch</u>	
Position (angular)	-	-	
Velocity (linear)	0-3 inch/sec	-	
	0-1.5 inch/sec	-	
Velocity (angular)	0-3600 rpm	<u>+1 rpm</u>	
	0-4000 rpm	<u>+1 rpm</u>	
	490-4600 rpm	<u>+1 rpm</u>	
	0-5000 rpm	<u>+1 rpm</u>	
	936-6200 rpm	<u>+1 rpm</u>	
	0-8000 rpm	<u>+1 rpm</u>	
	979-8000 rpm	<u>+1 rpm</u>	
	0-10,000 rpm	<u>+1 rpm</u>	

TABLE 1 (Continued)

Sensor	Range	Accuracies
Acceleration (linear)	See Noise and Vibration	
Acceleration (angular)	-	-
Fouling (in pipes)	5-100 $\mu$ m thickness	$\pm 1 \mu$ m
Condensation (moisture)	1-20 ppm	$\pm 10\%$ reading
	5-100 ppm	$\pm 10\%$ reading
Strain	0-50 $\mu$ in./in.	$\pm 2\%$ FS
	0-1000 $\mu$ in./in.	$\pm 2\%$ FS
Eddy current (electrical)	-	-
Opacity (turbidity)	0-3	$\pm 1\%$ reading
Relative humidity	10-100%	$\pm 2\%$
	5 to 100 ppm	$\pm 10\%$
Salinity	0.03 to 0.065 epm	-

Sensors are listed by parameter to be measured rather than by operating principle. Several entries for one type of sensor indicate there are several applications. Range entries apply only to needs; actual sensor ranges would likely be about 20 percent larger than the values listed. The first eight sensors in the list, "pressure" through "flow" appear in order of priority needed. For example, pressure sensors are expected to be used more often than any other sensor. The remaining sensors in the list, "transients" through "relative humidity," appear in random order. The list is not complete; blanks indicate that the information was not available at the time of publication.

Most of the listed sensors will be applied as on-line, continuous monitors, in a shipboard environment. Accuracy, repeatability, stability, and low output noise are very important because the measurements will be used to develop trends of parameter change with machinery performance degradation. Ideally, the sensors will maintain calibration longer than the operating life of the machine being monitored. Since this kind of calibration stability is likely not possible, simple calibration procedures are desirable with long times between calibration. Sensors will be

selected for intrinsic durability in the shipboard machinery space environment. Estimated MTBF's required are at least 5,000 hours. Operation life may be 40,000 hours. Simple maintenance features are desirable. At the present time there is very little independent test data available on the reliability and durability of the types of sensors listed.

#### MILITARY SPECIFIED SENSORS

Military specifications were searched for appropriate SMPMP sensors that are already qualified for the naval shipboard environment. Many sensor specifications were found. A few of the sensors described have outputs suitable for transmission to other parts of the ship. A summary of the appropriate military specifications are listed in Table 2; additional inputs are welcomed concerning other specifications applicable to the SMPMP that are not listed in Table 2. Table 2 is not complete and will be expanded in the next report. Some indicator specifications are included in Table 2.

TABLE 2 - SUMMARY OF NAVAL SHIPBOARD MILITARY SPECIFICATIONS POTENTIALLY USEFUL FOR SMPMP SENSORS

Parameter Sensed	Military Specification	Sensor
Pressure	MIL-P-24212	Bourdon tube, diaphragm, bellows, * straight tube*
Differential Pressure	MIL-D-24304	Diaphragm, * bellows, straight tube *
Temperature	MIL-T-23648**	Thermistors
Temperature	MIL-T-24388	Thermocouples, RTE's
Temperature	MIL-T-24387	Power and signal conditioner for MIL-T-24388
Temperature	MIL-T-19646	Bulbs
Flowmeter	MIL-F-24291	Electromagnetic *
Flowmeter	MIL-F-24259	Turbine, * vortex, * drag *
Liquid Level	MIL-L-24407	Differential pressure, * float, * probe, * absorption*
Liquid Level	MIL-L-23886	Magnetic float, differential pressure, electromagnetic, heat transfer*
Salinity	MIL-S-15103	Resistance

\*Not listed on QPL.  
\*\*NAVELEX Specification.

Table 3 lists the sensors by type, accuracy, and range requirements based on applicable military specifications. Qualified sensors are not yet available in all the types, ranges, and accuracies listed in Table 3.

TABLE 3 - RANGE AND ACCURACY REQUIREMENTS FOR MILITARY SPECIFIED SHIPBOARD SENSORS

Military Specification	Parameter Sensed	Sensing Element	Transduction Element	Range	Accuracy
MIL-F-24212	Pressure	Bourdon Tube Diaphragm Bellows* Straight Tube*	Strain gage Variable reluctance* Differential transformer	0-15 psia/g 0-30 psia/g 0-60 psia/g 0-100 psia/g 0-300 psia/g 0-600 psia/g 0-1000 psia/g 0-1500 psia/g 0-3000 psia/g 0-6000 psia/g 0-30 inch H <sub>2</sub> O 0-10 inch H <sub>2</sub> O  0-60 inch H <sub>2</sub> O 0-150 inch H <sub>2</sub> O 0-300 inch H <sub>2</sub> O  0-30 in. Hg, 0-15 psig 0-30 in. Hg, 0-30 psig 0-30 in. Hg, 0-100 psig 0-30 in. Hg, 0-150 psig	±1% (Static Error Band (SEB))  ±2% vibration  ±3% shock
MIL-D-24304	Differential Pressure	Diaphragm* Bellows Straight Tube*	Strain gage* Variable reluctance* Differential transformer	0-15 psid 0-30 psid 0-60 psid 0-100 psid 0-200 psid 0-600 psid 0-10 in. WCD 0-60 in. WCD 0-150 in. WCD 0-300 in. WCD	±1% SEB  ±2% vibration  ±3% shock
MIL-T-23645**	Temperature	Thermistor		-35° to 275° C	From 1 to 40% of indication
MIL-T-24388	Temperature	Platinum Resistance Temperature Element (RTE)		-40° to 200° F -40° to 400° F -40° to 1000° F	±2° F over -40° to 530° F ±3/8% of indication over 530° to 1000° F
		Is a Type K Thermocouple		-40° to 2000° F -40° to 400° F -40° to 1500° F	±4° F over 32°-530° F ±3/4% of indication over 530° to 1500° F
MIL-T-24387 (Power supply and signal conditioner only. Sensor is provided by MIL-T-24388)	Temperature	Type K Thermocouple Temperature Measuring Equipment		-40° to 200° F 0° to 400° F 0° to 700° F 0° to 1000° F 400° to 1200° F 500° to 1500° F	±0.02% °C temperature error  ±1% SEB ±2% vibration ±3% shock
		Platinum RTE Temperature Measuring Equipment		-40° to 200° F 0° to 400° F 0° to 700° F 0° to 1000° F	
MIL-F-24291	Flow Rate and Total Flow	Electromagnetic*		1-15 ft/sec for pipe diameters of 1 to 4 inches	±0.1 ft/sec over 1 to 3 ft/sec ±0.075 ft/sec over 3-15 ft/sec
MIL-F-24259	Flow Rate and Total Flow	Turbine*		10 to 1 of ordered range	Linearity, ±0.5%
		Vortex Velocity* Drag*		20 to 1 of ordered range	Linearity, ±1.0%
MIL-L-23886	Liquid Level	Magnetic Float Differential Pressure Electromagnetic Heat Transfer*		As specified by ordering document	3% FS
MIL-L-24407	Liquid Level	Differential Pressure,* Float,* Probe,* Absorption*	Strain gage,* Variable reluctance* Differential transformer* Ultrasonic*	As specified on ordering document	±1% SEB ±2% vibration ±3% shock
MIL-S-15103	Salinity	Resistance		0 to 1.5 eps	3% FS linear distance

\*Not listed on QPL or no QPL has been issued.  
\*\*NAVELEX Specification.

Table 3 adds to the statement of the SMPMP sensor needs listed in Table 1. Table 3 is a compilation of requirements for all shipboard uses including submarines (not included in the SMPMP) as estimated by the Naval Ship Engineering Center. Table 1 was estimated by several engineers at NAVSECPHILA and this Center. In general, the needs given in Table 1 agree with the military specified sensors given in Table 3. Specific areas where they do not agree are:

1. Greater accuracy and stability is required for sensors by SMPMP because trending analysis of the machinery operating condition will be done.
2. Table 1 lists many sensors for which no military specifications exist.

#### MILITARY QUALIFIED AND INDUSTRIAL OFF-THE-SHELF SENSORS

There is a large difference between the sensor ranges listed in the military specifications and those listed on the QPLs. Each of the QPLs for the military specifications listed in Table 3 was examined to check the availability of military qualified sensors.

Catalogs, instrumentation books, and summary articles from trade journals were searched to establish the state-of-the-art in sensors available from private industry that are not qualified to any particular environmental specifications. Table 4 is a list of such sensors which are readily available and could be qualified for use onboard ship by funding the appropriate development and testing efforts. Table 4 includes a list of military qualified sensors compiled from the QPLs, combined with commercially available sensors for pressure, temperature, fluid flow, liquid level, and salinity. For comparison purposes, the SMPMP sensor needs are also included from Table 1 to make it more obvious which sensors require development. All sensor and transducer elements are defined and discussed in Doebelin, Liptak, Moore, Yothers, Harvey, Soisson, and Norton.<sup>5-13</sup>

In interpreting Table 4, each complete section (headed by "Parameter Sensed") should be examined in total before arriving at conclusions. A sample interpretation of part of Table 4 is that under "Parameter Sensed Pressure," the range for all commercially available diaphragm type sensors is 0.01 mm Hg(a) to 10,000 psi(g).

**TABLE 4 - RANGE AND ACCURACY OF MILITARY QUALIFIED  
AND COMMERCIALY AVAILABLE SENSORS FOR THE SMPMP**

Sensing Element	Transduction Element	Military Qualified Products			Commercially Available Products		SMPMP Requirement Range and Accuracy*	
		Military Specification	Ranges Available	Accuracy	Total Range Covered (All Sensors)	Rated Accuracy		
<b>Parameter Sensed: Pressure</b>								
Bellows	Differential Transformer	MIL-D-24304	0-60 psid 0-100 psid 0-200 psid 0-400 psid	+1% SEB +2% vibration +3% shock	Not searched		<b>Differential</b> 0-1 psid ±1% FS 0-10 psid ±1% FS 0-50 psid - 0-200 in. H <sub>2</sub> O(d) ±1 in.	
Diaphragm	All	None	-	-	0.01 mm Hg(a) to 10,000 psig	+1% to 3% FS	<b>Gage</b> 0-0.5 psig - 0-1 psig ±1% to 10% FS 0-15 psig ±1% to 10% FS 20-40 psig ±0.5 psi 0-50 psig ±0.5 psi 0-100 psig ±1% to 10% FS 75-100 psig ±1.0 psi 120-140 psig ±1.0 psi 0-150 psig ±1% to 10% FS 0-300 psig ±1% to 10% FS 0-3000 psig ±1% to 10% FS	
	Strain gage, bonded	MIL-P-24212	0-100 psia/g 0-300 psia/g 0-600 psia/g 0-1000 psia/g 0-1500 psia/g 0-3000 psia/g 0-6000 psia/g 0-30 in. Hg(a) & 0-100 psia/g 0-30 in. Hg(a) & 0-150 psia/g	+1% SEB +2% vibration +3% shock	5 in. H <sub>2</sub> O(g) to 100,000 psig	+0.1% linearity	0-0.5 psig - 0-1 psig ±1% to 10% FS 0-15 psig ±1% to 10% FS 20-40 psig ±0.5 psi 0-50 psig ±0.5 psi 0-100 psig ±1% to 10% FS 75-100 psig ±1.0 psi 120-140 psig ±1.0 psi 0-150 psig ±1% to 10% FS 0-300 psig ±1% to 10% FS 0-3000 psig ±1% to 10% FS	
	Strain gage, thin film	None	-	-	5 in. H <sub>2</sub> O(g) to 100,000 psig	-	+0.25% FS	<b>Absolute</b> 5-20 psia - 15-70 psia - 0-25 psia - 15-55 psia - 15-300 psia - 22-32 in. Hg(a) - 0-80 in. Hg(a) -
	Piezoresistive	None	-	-	-	-	+0.2% FS	
	Capacitive	None	-	-	-300 in. H <sub>2</sub> O(g) to 10,000 psig	-	+0.01% rdg or +0.08% FS	
	Differential Transformer	MIL-P-24212	0-30 in. Hg(a) & 0-15 psia/g 0-30 in. Hg(a) & 0-30 psia/g 0-30 in. Hg(a) & 0-100 psia/g 0-30 in. Hg(a) 40-150 psia/g 0-30 in. Hg(a/g) 0-15 psia/g 0-30 psia/g 0-60 psia/g 0-100 psia/g 0-300 psia/g 0-10 in H <sub>2</sub> O(a/g) 0-60 in H <sub>2</sub> O(a/g) 0-150 in H <sub>2</sub> O(a/g) 0-300 in H <sub>2</sub> O(a/g)	+1% SEB +2% vibration +3% shock	-	-	+0.2% FS	
	Force balance	None	-	-	-	-	+0.25% FS	
	Motion balance	None	-	-	-	-	+0.5% FS	
	C Bourdon Tube	All	None	-	-	0.001 mm Hg(a) to 100,000 psig	+0.1% to 5% FS	
	Spiral Bourdon	Differential Transfer	MIL-P-24212	0-15 psig 0-30 psig 0-60 psig 0-100 psig 0-300 psig 0-600 psig 0-1000 psig 0-1500 psig 0-3000 psig 0-6000 psig 0-30 in. Hg(g) 0-30 in. Hg(a) & 0-15 psig 0-30 in. Hg(a) & 0-30 psig 0-30 in. Hg(a) & 0-100 psig 0-30 in. Hg(a) & 0-150 psig	+1% SEB +2% vibration +3% shock	-	+0.15% FS	
Force balance		None	-	-	-	+0.25% FS		
Motion balance		None	-	-	-	+0.1% FS		
All		None	-	-	-	+0.1% to 5% FS		
Differential Transformer		None	-	-	5 in. H <sub>2</sub> O(g) to 100,000 psig	-	+0.01% FS	
Optical encoder		None	-	-	-	-	+0.01% FS	
Motion balance		None	-	-	-	-	+0.5% FS	
Optical encoder		None	-	-	-	-	+0.2% FS	
Motion balance		None	-	-	-	-	+0.5% FS	
Quartz		None	-	-	0.001 mm Hg(a) to 100 psig	-	+0.1% to 5% FS	
Helical Bourdon	All	None	-	-	50 mm Hg(a) to 10,000 psig	+0.25% to 3% FS		
	Strain gage	None	-	-	6 in. H <sub>2</sub> O(g) to to 10,000 psig	-		
	Force balance	None	-	-	0.35 mm Hg(a) to 10,000 psig	+0.25% FS		
	Null balance	None	-	-	300 mm Hg(a) to 10,000 psig	-		
	Motion balance	None	-	-	-	-	+0.5% FS	
Vibrating Element	Magnetic pickup	None	-	-	-1 in. H <sub>2</sub> O(g) to 10,000 psig	+0.008% nonlinearity		
	Thermal	None	-	-	10 <sup>-6</sup> mm Hg(a) to 1 mm Hg(a)	+2% to 10% FS		
Ionization	None	-	-	-	10 <sup>-14</sup> mm Hg(a) to 0.1 in. H <sub>2</sub> O(g)	+10% to 20% FS		
	None	-	-	-	10 <sup>-3</sup> mm Hg(a) to 300 in. H <sub>2</sub> O(g)	+0.1% to 1% FS		
Deadweight	None	-	-	-	100 in. H <sub>2</sub> O(g) to 10 <sup>3</sup> in. H <sub>2</sub> O(g)	+0.1% FS		
	None	-	-	-	-	+0.1% to 5% FS		
Piston Gage	None	-	-	-	10 <sup>4</sup> to 10 <sup>6</sup> psi	+1% to 2% FS		
	None	-	-	-	10 <sup>4</sup> to 10 <sup>6</sup> psi	+0.1% to 5% FS		
Manganin Cell	None	-	-	-	0.1 mm Hg(a) to 100 psig	+0.25% to 1.0%		
	None	-	-	-	-	-		
Piezoelectric	None	-	-	-	-	-		

TABLE 4 (Continued)

Sensing Element	Transduction Element	Military Qualified Products			Commercially Available Products		SMPM Requirement Range Accuracy*
		Military Specification	Range Available	Accuracy	Range Covered (All Sensors)	Accuracy	
<b>Parameter Sensed: Temperature</b>							
Thermistor	Resistor	MIL-T-23649**	-55 to 275° C	1% to 40%	-320 to 600° F	±0.4° F	
ISA Type K Thermocouple		MIL-T-24388	-40 to 200° F -40 to 400° F -40 to 1500° F	+4° F for 32 to 530° F ±3/4% 530 to 1000° F	-300 to 3100° F	+1% °F for -75 to 200° F, +3/4% 200° to 600° F, +1/2% 600° to 3100° F	40° to 50° F ±0.2 °F 50° to 80° F ±1 °F 40° to 85° F ±0.3 °F 20° to 110° F ±0.5 °F 0° to 120° F ±0.2 FS -20° to 130° F - -40° to 140° F - 140° to 170° F ±1 °F 0° to 200° F ±1% FS 0° to 300° F ±1 °F -20° to 300° F - 300° to 600° F - -20° to 1000° F - 0° to 1500° F - -20° to 1600° F -
Platinum Resistance Temperature Element (RTE)		MIL-T-24388	-40 to 200° F -40 to 400° F -40 to 1000° F	+2 °F for -40 to 530 °F, +3/4% 530 to 1000 °F	-420 to 5000° F	±0.1 °F	
Type K Thermocouple Temperature Measuring Equipment		MIL-T-24387	0 to 1000° F 400 to 1200° F 500 to 1500° F	+0.02%/°C Temperature Error +1% SEB ±2% vibration ±1% shock	Not Searched	Not Searched	
Platinum RTE Temperature Measuring Equipment		MIL-T-24387	0 to 1000° F				
Glass Stem			Not Searched		-200 to 600° F	±0.1 to 2 °F	
Filled System			Not Searched		-300 to 1200° F	±0.5% to ±2% rdg	
Bimetallic			Not Searched		-80 to 800° F	±1 to 20 °F	
Semiconductors			Not Searched		-67 to 300° F	±2 °F at 77° F	
Pyrometers			Not Searched		0 to 6000° F	±1/2% to ±2% rdg	
<b>Parameter Sensed: Fluid Flow</b>							
Electromagnetic	Phase sensitive ratio voltmeter	MIL-F-24291	1-15 ft/sec** 1-4 in. dia	+0.1 ft/sec** for 1-3 ft/sec +0.075 ft/sec for 3-15 ft/sec	0.01 to 100,000 gpm	±1/2 to 1% FS	7.5 to 96 gpm - 0 to 140 gpm ±0.1 gpm or ±1% rdg 0 to 200 gpm ±0.2 gpm or ±1% rdg 100 to 400 gpm ±10 gpm 0 to 1200 gpm ±1 gpm or ±1% rdg 0 to 10 pounds (mass) ±3% FS
Turbine	Counter	MIL-F-24259	***	***	0.001 to 20,000 gpm	±1/4 to 1/2% rdg excluding nonlinearity	
Swirl	Pressure	None	-	-	0.1 to 1000 gpm	±1/2 to 1% rdg	
Vortex Shedding Orifice	Pressure	None	-	-	10 to 2000 gpm	±1 to 2% rdg	
Venturi	Differential pressure	None	-	-	0.001 to 20,000 gpm	±1% FS	
	Differential pressure	None	-	-	1 to 20,000 gpm	±1/4 to 3% FS	
Flow Nozzle	Differential pressure	None	-	-	1 to 20,000 gpm	±1/4 to 3% FS	
Pitot Tube	Differential pressure	None	-	-	20 to 20,000 gpm	±2 to 1% FS	
Elbow Tapes	Differential pressure	None	-	-	20 to 20,000 gpm	±5 to 10% FS	
Laminar	Pressure	None	-	-	0.0001 to 5 gpm	±1 to 2% FS	
Weirs, Flumes	Pressure	None	-	-	1 to 20,000 gpm	±2 to 5% FS	
Target Meters	Differential pressure	MIL-F-24259	***	***	1 to 1000 gpm	±1/2 to 2% FS	
Rotameters		None	-	-	0.02x10 <sup>-6</sup> to 1000	±1/2 to 2% FS	
					0.0005 to 50 gpm	±1 to 2% FS	
						±1% FS	
						±3 to 5% FS	
					0.1 to 1000 gpm	±1/2 to 1% FS	
Positive Displacement Metering Pumps	Shaft Rotation	MIL-N-2082	***	***	0.1 to 3000 gpm	±1/2% rdg	
					10 <sup>-6</sup> to 200 gpm	±0.1 to 1% rdg	
					1 to 1000 psi	±1% FS	
<b>Parameter Sensed: Liquid Level (Oil, Water, Freon)</b>							
Magnetic Float		MIL-L-23886	Not specified	±3% FS			0 to 1 in. ±0.1 in. 0 to 10 in. ±1 in. 0 to 12 in. ±10% FS 0 to 20 in. ±1 in. 0 to 30 ft ±1 ft
Differential Pressure							
Electromagnetic							
Heat Transfer***					Not searched	Not searched	
Differential Pressure		MIL-L-24407		±1% SEB			
Float***							
Probe***							
Absorption***							
<b>Parameter Sensed: Salinity</b>							
Salinity	Resistance	MIL-S-15103	0 to 1.5 EPH	3% FS linear (diaphragm)	Not searched	Not searched	

\*These two columns are included from Table 1 for convenient reference and are not to be read as part of Table 4.  
\*\*NAVELEX Specifications.  
\*\*\*Not listed on QPL or no QPL issued.

Note: Sample interpretation of Table 4 under Parameter Sensed: Pressure.  
The range for all commercially available diaphragm type sensors is 0.01 mm Hg(a) to 10,000 psi(g). No diaphragm type pressure sensor with a capacitive transducer is qualified to any Military Specification. Capacitive diaphragm type sensors are available commercially covering the range of -300 inches of water to 10,000 psi(g) with an accuracy of +0.01 percent of reading or +0.08 percent of full scale. There are ten ranges of military qualified diaphragm, differential transformer type, sensors available. One particular qualified gauge range is 0-300 psi(a) or (g).

No diaphragm type pressure sensor with a capacitive transducer is qualified to any military specification. Capacitive diaphragm type sensors are available commercially covering the range of -300 inches of water to 10,000 psig with an accuracy of  $\pm 0.01$  percent of reading or  $\pm 0.08$  percent of full scale. There are ten ranges of military qualified, diaphragm, differential transformer type, sensors available. One particular qualified range is 0-300 psia or psig.

The two right hand columns in Table 4 under "SMPMP Requirements" list for convenience the required accuracy and range from Table 1.

Not all military specifications have QPLs associated with them. However, this does not necessarily mean that equipment has not been purchased and successfully operated to meet the requirements of a given military specification. For example, MIL-F-24291 (Electromagnetic Flowmeters) has no associated QPL but specific flowmeters have successfully passed first article tests for MIL-F-24291 during production exercises.\*

The following observations are made from Table 4: (These observations are based only on accuracy and range requirements. A more complete description of sensor needs and availability will be given in the second report.)

1. Most of the SMPMP pressure sensor requirements for range and accuracy are covered by sensors qualified to MIL-P-24212 and MIL-D-24304. Performance trending analysis and failure prediction may require sensors with better accuracy than is presently listed. A significant increase in accuracy could be achieved by developing more accurate types of the commercially available sensors to be qualified products. However, the SMPMP need for increased accuracy has not been fully demonstrated.

2. Most of the SMPMP required temperature sensors are available in the form of devices qualified to MIL-T-24388 and MIL-T-24387 over the range needed but not to the accuracy needed. Commercial temperature sensors are available to the accuracy needed for SMPMP. A qualification development effort to increase the accuracy of shipboard temperature

---

\*If there are other military specifications listed in Table 4 without QPLs but having had equipment purchased and successfully tested, the author would appreciate learning this for inclusion in the second report.

sensors may be needed. Also, since MIL-T-24388 provides only for "thermo-well" type mountings, a specification development effort may be required to include embedment and special surface type temperature sensors in MIL-T-24388 or in some other appropriate military specification.

c. There are no QPLs associated with MIL-F-24259 and MIL-F-24291. However, electromagnetic flowmeters have successfully passed first article tests for MIL-F-24291 and are, therefore, available for most of the SMPMP requirements listed in Table 4. The only exception is for high flow rates where electromagnetic flowmeters could be operated at larger diameters than the 4-inch maximum now specified in MIL-F-24291. The author does not presently know of any equipment tested to MIL-F-24259 but expects that this equipment exists.

d. Commercial products in the areas of liquid level and salinity indicators were not searched for this report due to time limitations. The SMPMP required liquid level sensors are available (to the needed accuracy) and qualified to MIL-L-23886.

#### CONCLUSIONS

Most of the pressure sensors required for the SMPMP are available as military qualified items. Accuracy improvements could be made by qualifying the more accurate commercially available sensors to more stringent accuracy specifications. This may be necessary for trending analysis of machinery operating condition.

Most of the temperature sensors required for the SMPMP are available as military qualified items over the range needed but not with the accuracy needed. A development program may be needed to qualify commercially available sensors to better accuracy than is currently required in military specifications. A development program may also be needed to qualify embedment and special surface type temperature sensors for operation in the shipboard environment.

Most of the flow sensors required for SMPMP are available in hardware packages that have passed first article tests (but are not on a QPL). Many of the flow sensors available in military tested packages have serious limitations such as high cost and large cumbersome hardware packages; output transmission is not always available. As a result the choice of flow sensors for SMPMP is severely limited.

Some of the level sensors required for the SMPMP are available as qualified military items. More development work is needed to expand the list of qualified level sensors to more completely cover the SMPMP program needs.

#### COMMENTS

Following are comments on the subject of sensor availability for the SMPMP that are unsubstantiated in this report but are based on effort expended while doing the required research for this document. They should be regarded as preliminary results for the second report.

Many sensors are already available in military qualified packages that will meet the needs of the SMPMP. Examples are pressure, temperature, liquid level, and salinity. These military qualified sensors do not always use the best sensing technique for the shipboard environment but do represent the most cost effective sensors presently available that can be used in the SMPMP with little or no development effort. The remaining sensors required for the SMPMP are available from commercial sources. However, developing some of these as qualified sensors to operate in the military environment would be a major effort.

Accuracy, repeatability, and calibration drift with time of the military qualified sensors and commercially available sensors are particularly important. Since the information sensed for SMPM will be used in trending analysis of the operating condition of the shipboard machinery, high accuracy, long-term stability, and good resolution are desired. If very accurate and stable sensors are not available, very frequent sensor calibration may be required to prevent sensor calibration drift.

The reliability, durability, and stability of both the military qualified sensors and commercially available sensors are not presently known and are important areas to investigate. Test programs on sensor durability may be required.

Many of the parameters required to be sensed for SMPM are presently measured using manpower and off-line sample analysis. On-line sensors able to operate continuously over thousands of hours are needed. Not all types are available yet. Good examples are sensors to measure metal particles in hydraulic oil, water in oil, and oil in water. Present methods use sampling and off-line analysis or indirect measurements.

More direct sensors are needed, particularly wear sensors. Many of the sensors presently available can be used to measure symptoms such as particles in hydraulic and lube oil, vibration, or increased operating temperature. Only a few sensors are available that measure the degradation itself such as increased clearances, cracks, or wall thicknesses. The difficulty of such measurements and the multiplicity of sensors required explains the slow development of such direct sensors. As a result of the lack of direct sensors, some types of failure may be hard to predict and some causes of failure may be difficult to assess.

On the other hand, in many applications it might be cost effective to expend considerable development and qualification effort on a highly sophisticated symptom analyzer (such as type, size, number, and possibly even shape of wear particles in lubricating and hydraulic oil) in order to deduce the incipient failure modes and predict failure.

Tradeoffs must be considered and the choice of approach will probably depend on the type and complexity of machinery being monitored. It is likely however, that a full array of both direct and indirect sensors will eventually be required to cover the diversity of applications anticipated.

Direct digital or quasidigital\* sensors are desirable but perhaps are one of the least important development needs because the SMPMP plans to utilize the Shipboard Data Multiplexing System (SDMS) which can accept analog inputs. Digital sensors are desirable if they result in improvements such as being more reliable, less expensive, more maintainable, more accurate, etc.

#### FUTURE WORK

The remaining effort in the sensors portion of the SMPMP preliminary development at this Center will result in a more detailed sensors-matrix report published during fiscal year 1979. This second report will outline the state-of-the-art and availability for all the required sensors listed in Table 1 of this report. Development needs will be identified. Sensor

---

\*A quasidigital sensor is one whose output is not completely digital but is easily converted to a digital format. An example is a frequency output.

parameters will be listed in greater detail than contained herein, particularly in the areas of the commercially available sensors and the laboratory available sensors. The sensor portion of the SMPMP is expected to be continued for several years and should result in further refinements to the statement and description of availability of sensors.

#### ACKNOWLEDGMENTS

The author gratefully accepted the assistance of several people from this Center while assembling this document. Data inputs were provided in the areas of commercially available pressure and temperature sensors by Herbert A. Palmer and William J. Harney. Also, the help provided by William J. Harney in assembling Table 4 was especially appreciated. Administrative and general technical assistance was provided by William R. McWhirter, Jr. The author also acknowledges the helpful criteria review provided by E. Wittkorn of NAVSECPHILADIV and Lyman W. Griswold of this Center.

#### REFERENCES

1. Shipboard Machinery Performance Monitoring Program, NAVSECPHILADIV Project T-1311, Interim Rept 1, FFG-7 Machinery Failure Analysis
2. MIL-STD-167 Mechanical Vibrations of Shipboard Equipment
3. MIL-S-901 Shock Tests, H.I. (High-Impact); Shipboard Machinery, Equipment and Systems, requirements for
4. MIL-I-983E (SHIPS) Interior Communication Equipment, Naval Shipboard; Basic Design Requirements for (15 Aug 1966)
5. Doebelin, Ernest O., "Measurement Systems," McGraw-Hill (1975)
6. Liptak, Bela G., ed., "Instrumentation in the Processing Industries," Chilton (1973)
7. Liptak, Bela G., ed., "Instrument Engineers Handbook," Vol. 1, Chilton (1969)
8. Liptak, Bela G., ed., "Instrument Engineers Handbook, Supplement 1 to Vol. I and II," Chilton (1972)
9. Moore, Ralph L., ed., "Basic Instrumentation Lecture Notes and Study Guide, Measurement Fundamentals," 2nd ed., Instrument Society of America (1976)
10. Yothers, Mark T., ed., "Standards and Practices for Instrumentation," 5th ed., Instrument Society of America (1977)
11. Harvey, Glenn F., ed., "ISA Transducer Compendium," 2nd ed., Parts 1, 2, and 3, IFI/Plenum (1969)
12. Soisson, Harold E., "Instrumentation in Industry," Wiley-Interscience (1975)
13. Norton, Harry N., "Handbook of Transducers for Electronic Measuring Systems," Prentice-Hall (1969)

INITIAL DISTRIBUTION

		CENTER DISTRIBUTION	
Copies		Copies	Code
11	NAVSEA	2	273
	1 SEA 05D	1	2731
	3 SEA 05R	5	2731 (W. McWhirter)
	5 SEA 513 (R. Karsch)	1	2732
	2 SEA 99612	50	2732 (H. Whitesel)
6	NAVSECPHILADIV	1	2732 (H. Palmer)
	1 SEC 6723 (T. Graf)	1	2732 (W. Harney)
	3 SEC 6732 (H. Wegner, J. Foti, F. Kennedy)	1	522.2
	1 SEC 6761 (E. Wittkorn)	1	5231.1
	1 SEC 6762 (T. Canniere)		
5	ManTech of N.J. Corp (H. Hegner)		
12	DDC		

**DTNSRDC ISSUES THREE TYPES OF REPORTS**

**1. DTNSRDC REPORTS, A FORMAL SERIES, CONTAIN INFORMATION OF PERMANENT TECHNICAL VALUE. THEY CARRY A CONSECUTIVE NUMERICAL IDENTIFICATION REGARDLESS OF THEIR CLASSIFICATION OR THE ORIGINATING DEPARTMENT.**

**2. DEPARTMENTAL REPORTS, A SEMIFORMAL SERIES, CONTAIN INFORMATION OF A PRELIMINARY, TEMPORARY, OR PROPRIETARY NATURE OR OF LIMITED INTEREST OR SIGNIFICANCE. THEY CARRY A DEPARTMENTAL ALPHANUMERICAL IDENTIFICATION.**

**3. TECHNICAL MEMORANDA, AN INFORMAL SERIES, CONTAIN TECHNICAL DOCUMENTATION OF LIMITED USE AND INTEREST. THEY ARE PRIMARILY WORKING PAPERS INTENDED FOR INTERNAL USE. THEY CARRY AN IDENTIFYING NUMBER WHICH INDICATES THEIR TYPE AND THE NUMERICAL CODE OF THE ORIGINATING DEPARTMENT. ANY DISTRIBUTION OUTSIDE DTNSRDC MUST BE APPROVED BY THE HEAD OF THE ORIGINATING DEPARTMENT ON A CASE-BY-CASE BASIS.**