

AD-A074 693

ADVISORY GROUP FOR AEROSPACE RESEARCH AND DEVELOPMENT--ETC F/G 9/2  
USE OF COMPUTER STRUCTURAL PROGRAMS FOR THE DYNAMIC ANALYSIS OF--ETC(U)  
AUG 79 R BARBONI, G MORELLI

UNCLASSIFIED

AGARD-R-680

NL

| OF |

AD  
A074693



END  
DATE  
FILMED  
11-79  
DDC

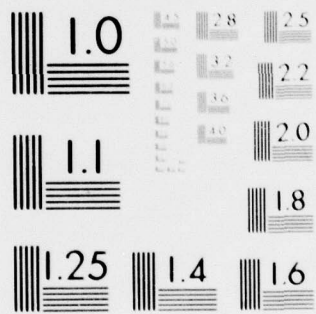

MICROCOPY RESOLUTION TEST CHART  
NATIONAL BUREAU OF STANDARDS-1963-A

Handwritten initials in a circle

AGARD-R-680

AGARD-R-680

# AGARD

ADVISORY GROUP FOR AEROSPACE RESEARCH & DEVELOPMENT

7 RUE ANCELLE 92200 NEUILLY SUR SEINE FRANCE

ADA 074693

AGARD REPORT No. 680

LEVEL II

## Use of Computer Structural Programs for the Dynamic Analysis of Satellites Structures

DDC  
RECEIVED  
OCT 4 1979  
A

**DISTRIBUTION STATEMENT A**  
Approved for public release;  
Distribution Unlimited

DDC FILE COPY

NORTH ATLANTIC TREATY ORGANIZATION



DISTRIBUTION AND AVAILABILITY  
ON BACK COVER

79 10 04 022

14  
AGARD-R-680

NORTH ATLANTIC TREATY ORGANIZATION  
ADVISORY GROUP FOR AEROSPACE RESEARCH AND DEVELOPMENT  
(ORGANISATION DU TRAITE DE L'ATLANTIQUE NORD)

6  
AGARD Report No.680  
USE OF COMPUTER STRUCTURAL PROGRAMS FOR THE  
DYNAMIC ANALYSIS OF SATELLITES STRUCTURES

10  
by  
R. Barboni  
Istituto di Tecnologia Aerospaziale  
Università di Roma  
V. Eudossiana 16 - 00184 Roma  
and  
G. Morelli  
Compagnia Nazionale Aerospaziale  
Via Salaria km 9.300 - Roma

11 Aug 77  
12 17

|                     |                                     |
|---------------------|-------------------------------------|
| ACQUISITION FOR     |                                     |
| NTIS GRA&I          | <input checked="" type="checkbox"/> |
| DDC TAB             |                                     |
| Unannounced         |                                     |
| Justification       |                                     |
| By _____            |                                     |
| Distribution/ _____ |                                     |
| Availability Codes  |                                     |
| Dist.               | Avail and/or special                |
| A                   |                                     |

DISTRIBUTION STATEMENT A  
Approved for public release  
Distribution Unlimited

400043 7/15

## THE MISSION OF AGARD

The mission of AGARD is to bring together the leading personalities of the NATO nations in the fields of science and technology relating to aerospace for the following purposes:

- Exchanging of scientific and technical information;
- Continuously stimulating advances in the aerospace sciences relevant to strengthening the common defence posture;
- Improving the co-operation among member nations in aerospace research and development;
- Providing scientific and technical advice and assistance to the North Atlantic Military Committee in the field of aerospace research and development;
- Rendering scientific and technical assistance, as requested, to other NATO bodies and to member nations in connection with research and development problems in the aerospace field;
- Providing assistance to member nations for the purpose of increasing their scientific and technical potential;
- Recommending effective ways for the member nations to use their research and development capabilities for the common benefit of the NATO community.

The highest authority within AGARD is the National Delegates Board consisting of officially appointed senior representatives from each member nation. The mission of AGARD is carried out through the Panels which are composed of experts appointed by the National Delegates, the Consultant and Exchange Programme and the Aerospace Applications Studies Programme. The results of AGARD work are reported to the member nations and the NATO Authorities through the AGARD series of publications of which this is one.

Participation in AGARD activities is by invitation only and is normally limited to citizens of the NATO nations.

Published August 1979

Copyright © AGARD 1979  
All Rights Reserved

ISBN 92-835-1335-5



Set and printed by *Technical Editing and Reproduction Ltd*  
*Harford House, 7-9 Charlotte St, London, W1P 1HD*

## PREFACE

The past decade has seen an enormous growth in the use of computerized techniques for structural analysis and many programs are commercially available to assist in this work. Each program has its merits and disadvantages and it is fair to say that none are universally acceptable at the present time.

An Ad Hoc Group to consider the problems of these major computer programs was established by the Structures and Materials Panel at its 45th meeting. Following discussions within the Group it was decided to invite the presentation of Specialist Pilot Papers in order to obtain expert guidance. These papers were subsequently presented at the 47th meeting in Florence, Italy. Two of these by Mr Andrew and Mr Taig dealt specifically with the problems of selecting major programs from those currently available and have been published as AGARD Report R-670. The third paper by Dr Barboni and Dr Morelli deals with a somewhat different aspect of the problem in that, based on investigations of certain specific problems of spacecraft, it makes a number of suggestions for the future development of computer programs. Because of this difference in emphasis the paper is published separately.

J.A.DUNSBY  
Chairman  
Ad Hoc Group on Structural Analysis  
Computer Programs

A065766

## CONTENTS

|  | Page   |
|--|--------|
| <b>PREFACE</b>   |        |
| by J.A.Dunsby  | iii    |
| <b>SUMMARY</b>   | 1      |
| <b>1. INTRODUCTION</b>   | 1      |
| <b>2. GENERAL ASPECTS OF COMPUTER PROGRAMS FOR STRUCTURAL ANALYSIS</b> | 1      |
| <b>3. THE IMPORTANCE OF DYNAMICS IN THE SPACE STRUCTURE</b>            | 2      |
| <b>4. STRUCTURAL DYNAMICS AND THE COMPUTER USE</b>                     | 3      |
| <b>5. FEATURES OF STRUCTURAL DYNAMIC COMPUTER PROGRAM</b>              | 4      |
| <b>6. FUTURE TRENDS</b>  | 5      |
| <b>REFERENCES</b>  | 5      |
| <b>FIGURES</b>   | 7 - 11 |

# USE OF COMPUTER STRUCTURAL PROGRAMS FOR THE DYNAMIC ANALYSIS OF SATELLITES STRUCTURES

## SUMMARY

The paper deals with the essential aspects of computer programs for structural analysis. The dynamic problems of satellites structures are pointed out.

Possible future trends in these fields are outlined and, finally, the meaningful features in dynamic structural computer programs are presented.

## 1. INTRODUCTION

The use of digital computers has deeply influenced natural and engineering sciences (1) but, in the field of structural design, most of the advantages of computer use in structural design must be regarded, at present, as potential rather than actual, because the successful application of computers to anything more than a limited part of the structural design process still has many obstacles to overcome.

In the early days of the computer, about 1950, its main active use in structural engineering was in the aircraft industry. At that time, a need arose for the relatively accurate analysis of complex statics and dynamics problems. Great progress was made in the capability for the static and dynamic analysis of framed structures. Later, the aircraft and the aerospace industry had a need for the analysis of surface-type structures, as contrasted to framed structures, along with the resources to meet this need (2) (3). In this area, no meaningful static and dynamic analysis is feasible unless the classical concepts of structural mechanics are reshaped and extended with a computer oriented philosophy.

Hence the great development of interest and capability in the area of finite element analysis which can be considered as the most powerful and flexible computer oriented tool. Structural analysis progressed much more rapidly as a result of these developments, and it is not at all surprising that the list of computer programs is both large and rapidly growing.

This paper will give some attention to the essential aspects of the structural dynamics of satellites by considering some of the computer programs which are available. Moreover, it is intended to point out some of the most critical problems encountered by the authors in making dynamic models of aerospace structures such as the OTS antennas and the SIRIO satellite. Finally, it will consider possible future trends, suggested by experience of the computer programs used in satellite structural analysis.

## 2. GENERAL ASPECTS OF COMPUTER PROGRAMS FOR STRUCTURAL ANALYSIS

Many computer programs were developed with different aims to cover the various aspects of structural analysis.

Some programs, available on the open market, were developed under the sponsorship of government agencies, consortia and Universities. Many other programs, developed by industry for its specific needs, are not easily available.

A general view concerning the major areas of structural analysis and the relevant available computer programs is subsequently reported.

- (a) *Stress and deformation analysis*: Most of the programs developed at the present time are those related to this area and they are based generally on "finite element technique". These programs can be general-purpose such as STRUDL (4), NASTRAN (5), ASKA (6), or specialized in some area, such as STRESS (7), SOLID SAP (8).

By taking NASTRAN as a significant example of these computer programs, we remark that it is an analysis program, as contrasted to a design-type program which would have provision for both analysis and member selection. NASTRAN is appropriate for special or complex problems where the correct method of design at the present time is (a) analysis by computer and (b) member selection by some independent means (by hand or perhaps by another computer program).

- (b) *Dynamic analysis*: This area is generally covered as case of the above mentioned general purpose program. Nevertheless some special features are included to implement the dynamic aspect of the program and they come

essentially from a mathematical point of view (reduction of numbers of degrees of freedom (d.o.f.), displacements substituted by normal modes...).

- (c) *Structural configuration and optimization*: The computer possibility of automatically selecting a structural configuration approaching the optimum has many attractions for the structural engineer. However, there are substantial difficulties in this area even with the computer, and at the present time the programs available in this area are generally rather specialized and limited in scope. Some examples in the static field are DESAP 1 (9) and DESAP 2 (10); the design objective is to find the element sizes that minimize the total structural weight without changing the layout of the structure.
- (d) *Non-linear analysis*: The programs developed are concerned essentially with the linear behaviour of finite elements. Some effort was made in the non-linear field, such as piecewise linear static analysis, but more complicated problems arise in the dynamic field. Only the user's ingenuity can solve some problems in this area.

Other features not strictly related to structural analysis are those programs generated to improve computer-engineering communication. A number of researchers have seen fit to develop means to assist the program writer. Work of this nature has been done at MIT, at the University of Illinois and for the "GENESYS" project in Great Britain (11). Finally, a considerable effort was made to improve the conventional interface between computer and user to minimize time for input data preparation. At present, some programs are quite promising by giving the structural engineer a fast way of checking the correctness of data input, in addition to a very useful output representation.

### 3. THE IMPORTANCE OF DYNAMICS IN THE SPACE STRUCTURE

Present space programs already involve operation of complex and flexible structures which require an extreme lightness of construction to optimize the design in terms of weight. It means that the design critical loading conditions for the spacecraft are mostly of dynamic kind and are significantly influenced by spacecraft dynamic behaviour.

Principal concerns in the structural dynamics are:

- (a) Primary structural loads, experienced by a satellite, which occur as a result of quasistatic loads due to acceleration or low frequency launch vehicle bending modes. Another possible source is a longitudinal mode of vibration of the launcher known as POGO (12). These loads are those to be considered as design loads or as a basis for establishing realistic design criteria.
- (b) Dynamic coupling between launch vehicle and spacecraft structure, which is relevant to primary structure and its various components.
- (c) Interaction between the satellite control system and the various parts of the structure, especially if large and flexible as, for example, the solar arrays.
- (d) Docking maneuver problems which must be considered in two ways; one is the changing of modal properties of the system during the docking event due to engagement of two bodies; the second one is the excitation of large non-linearities as, for example, propellant sloshing.

Therefore, structural dynamics influences significantly the design of large, flexible and complex structure systems and the dynamic characteristics must be defined accurately in the early stage of design.

Looking at primary structural loads and dynamic coupling in more detail, the most important launch vehicle modes of vibration have generally very low frequencies, less than 20 Hz. If spacecraft have normal modes out of this frequency range, little dynamic coupling may be expected and the launch loads may be considered as static loads.

The aforementioned problems can be synthesized as "structural design under dynamic constraints". As an example of this kind of problem, we consider a medium size telecommunication satellite to be launched by the SPACE SHUTTLE.

To achieve the geosynchronous transfer orbit from SPACE SHUTTLE circular parking orbit, it is necessary to use an upper stage. Therefore the SHUTTLE payload will consist of spacecraft, upper stage and a structural assembly to support and to separate both of them from the Shuttle.

To design an optimum configuration of such a structural assembly, the following main requirements should be satisfied:

- minimum weight;
- minimum length;
- geometrical constraints of the Shuttle;
- dynamic characteristics such that the payload is dynamically decoupled from Shuttle;
- accommodate different spacecraft.

The approach to have the lowest payload natural frequencies higher than the launch vehicle ones does not lead to a weight optimized configuration. Then it is necessary to accept that payload frequencies are within the range to be avoided, provided that they are decoupled from launch vehicle fundamental frequencies.

In this case, only the use of very sophisticated and reliable models can ensure that the dynamic behaviour of the overall system is in compliance with the requirements.

#### 4. STRUCTURAL DYNAMICS AND THE COMPUTER USE

- (a) Some results of joint efforts done by the University and industry are presented as an interesting learning experience which came to the surface in the field of mathematical modelling of structural dynamics.

One effort involved development of a NASTRAN model of the spot beam N° 4 antenna of the OTS satellite. The model was developed to verify that the natural frequencies are decoupled from the satellite, and the validity of the model was established by comparison with experimental tests.

A detailed description of the model can be found in (13) (14). The structural system has been considered to be an assemblage of two subsystems, one the reflector, the second the supports. Much care has been given to the study of the models which have been constructed with the concept of using the minimum number of elements compatible with a consistent precision of results without burdening the NASTRAN program with unnecessary details. This has been done after a preliminary evaluation of the dynamic behaviour of some antenna elements.

Much effort was needed for the dynamic model of the SIRIO satellite owing to the size and complexity of the structural elements (15) (16). Due to computer size limitations associated with long computer run times, the spacecraft configuration has been considered to be an assemblage of three subsystem components (substructures) (Fig.1).

- the SHF platform with all the instrumentation, including the despun motor and the SHF antenna;
- the main load platform, including all the instrumentation, the auxiliary propulsion subsystem and the lower part of the central cone with the load platform basket;
- the upper part of the central cone, including the auxiliary platforms with the apogee motor.

The mass and stiffness matrices for each substructure were determined separately, then reduced degree of freedom of these matrices were used to obtain the total system. One substructure (SHF platform) needed a more detailed analysis due to its lowest frequency being close to one satellite fundamental mode. This was done compatibly with interface problems, i.e. to avoid burdening the other substructure models.

The final satellite model, delivered to NASA for dynamic coupling analysis, represented a 25 grid points model resulting in overall 65 by 65 free-free mass and stiffness matrices. Comparison of theoretical data, obtained from this model, and experimental ones, carried out during vibration tests, is shown in Figures 2 and 3.

The good agreement between the above data is an indication of the mathematical model reliability. Moreover all the fundamental resonant frequencies of the satellite and its substructures are decoupled.

- (b) The previous experience showed us that the most important conditions for a computer method are the possibility of:
- an economical application,
  - numerical stability,
  - flexibility for the solution of different structures,
  - flexibility to element changes.

Up to now there does not exist a computer program which satisfies completely all the above conditions at the same time. In order to obtain reliable results in a cost effective way, it is suggested as first step to carry out a preliminary analysis with a very simple model. This kind of investigation is essentially useful to:

- identify the most important elements which can produce undesirable frequencies,
- not discard prematurely promising approaches because there are not sufficient resources to investigate many of them.

Hence, the analysis proceeds by using detailed models and more sophisticated computer programs. Sometimes, only the ingenuity of the structural engineer can take advantage of preliminary analysis results to prepare an implemented model because the programs are not usually able to take advantage of them automatically.

In case of re-design of some element, generally it is necessary to remake the model not only for the element itself but also for elements located along its boundary. The need could produce a cascade effect with onerous consequences on the modelling process. Hence the dynamic analyses are approached by an iterative process of design, verification, redesign and so on which is not automatically drawn out by computer. The problem is more complex if we consider that the analyses must be generally carried out under dynamic constraints which at substructure level are not, a priori, known.

In conclusion, it seems that an effort should be made in this area to develop such a computer program able to solve the aforementioned problem more especially from an industrial than from a theoretical point of view.

## 5. FEATURES OF STRUCTURAL DYNAMIC COMPUTER PROGRAM

- (a) From a general point of view the structure dynamics computer program should be developed to meet specifications which could take into account the following main general aspects:
- to be economically competitive at "every level" of model detail;
  - to combine the best of the state of art in the discipline of mechanics, numerical methods and computer programming;
  - to organize the program to be dynamic analysis oriented;
  - to establish computer independence;
  - to provide for automatic modification of the structural model;
  - to satisfy automatically the dynamic constraints;
  - to support the program by a data bank of easy access and implementation;
  - to embody a large three-dimensional structure capability;
  - to operate under a time-sharing system.

The possibility of increasing the economical efficiency of the process consists of a program tailored to the model size. Figure 4 sketches typical curves of computer cost vs number of degree of freedom. General purpose programs (continuous line) have for few d.o.f., large size memory requirements and not insignificant program loading times. By increasing the complexity of the model the computer cost is more sensitive to the number of d.o.f. It is suggested to develop a program which also has the memory size requirement depending on degrees of freedom as sketched in Figure 4 (dashed line).

This "tailored program" becomes more advantageous if we note that, beyond a certain number of d.o.f., it is necessary or convenient to introduce the substructuring technique. This means restarting the process from the beginning and the user can work always in the optimum area.

As regards the need to satisfy automatically the dynamic constraints, two main aspects are involved:

- optimization under dynamic constraints
- definition of substructure dynamic constraints.

Although most of the basic principle of structural optimization are well established there is remarkably little general use of such advanced techniques in practical design organization.

Grateful acknowledgement must be given to the Working Group on Structural Optimization of the AGARD Structures and Materials Panel for the meetings arranged to cover both theoretical and practical aspects of optimization. Nevertheless, certain areas have perhaps not received, for our scope sufficient attention. We refer primarily to the above mentioned second aspect which is to define the substructures dynamic constraints when the dynamic constraints are known for the structure as a whole.

The procedures usually employed in the design or modification of complex structures suggest designing structural components or substructures by different engineering groups or at different times. It is desirable, therefore, to know the dynamic constraints on substructures so that such designs and modifications may proceed independently.

For example, if the natural frequencies of a satellite cannot be close to a given value, what are the constraints on every substructure in order to be sure that none of the satellite frequencies is close to the given value?

- (b) A general flow diagram of the suggested "tailored program" for dynamic analysis is shown in Figure 5.

The main features of this program are concerned with the following aspects:

- "large-element" modelization,
- automatic re-modelling by using optimization techniques and data bank,
- determination of substructure dynamic constraints.

Other blocks of the flow diagram are, of course, directly derived from existing programs, hence they are not discussed hereinafter.

The necessary input data for modelization are the topological parameters generated through the general configuration and geometrical constraints. Other input data are the dynamic constraints on the satellite as a whole.

The first step is the modelization of the complete satellite by using "large-elements" representing the actual structure with a reduced number of d.o.f. established by the user. Each "large-element" has to be able, by maintaining unchanged the topological picture, to split itself into smaller "large-elements" in order to have a more detailed model with a larger number of degrees of freedom.

The automatic growth of the model size in the frame of "large-elements" is supported by a strict interaction with the structural engineer. When the number of d.o.f. exceeds a certain value, the substructuring technique is automatically introduced by the computer itself. Each substructure is derived with its relevant constraints, geometrical and dynamic, and hence the process starts again through the "large-element" techniques.

We remark that, at present, no reliable criteria are available to define accurately the substructure dynamic constraints which derive directly from those of the complete structure.

Finally the automatic re-modelling has to be intended as an optimization technique under constraints. Supports to this process are:

- data bank
- implementation of finite elements.

Data bank means a computerized technical library, which is very attractive in principle. From such a library, the structural designer or his program could quickly extract some properties of materials or typical elements used in space structures. However, there are a number of practical difficulties which must be solved before such data banks become really useful. To be effective, a data bank requires both an efficient wide-spread communication system and cooperation among the users.

The implementation of finite elements should permit finding "special" elements which have the possibility of optimization at the level of the element itself. This should lead to a critical review of the finite element theory from an optimization point of view.

Present trends involve piecewise optimization by finite elements, each one of constant physical and geometrical characteristics. The suggested implementation should overcome this concept in order to obtain finite elements with variable characteristics.

A parallel study should evaluate the possibilities of these "special" finite elements with respect to the conventional ones from computer time point of view.

## 6. FUTURE TRENDS

In conclusion, our suggestions on future trends of structural dynamic analysis by computer can be summarized as follows:

- finite "large-element" able to split itself automatically
- data bank
- "tailored program" according to the model size
- evaluation of substructure dynamic constraints
- "special" finite element to reach an optimization at element level.

## REFERENCES

1. Argyris, J.H. *The Impact of the Digital Computer on Engineering Sciences*. The Aeronautical Journal, Vol.74, Nos 709, 710 - January, February 1970.
2. Argyris, J.H. Griger, J. *Computer Methods in Structural Analysis of Aerospace Structures*. Computer in Space Industry Symposium, Rome, April 6 - 8, 1976.
3. Argyris, J.H. Doltsinis, J.St. *Aspects of the Finite Element Method as Applied to Aerospace Structures*. ISD-Report No.138.
4. Biggs, J.M. Jordan, J.C. *ICES System Manuals of Particular Interest to Structural Engineers*. Civil Eng. Syst. Lab., MIT, Cambridge.
5. McCormick, C.W. *NASTRAN, User's Manual, Theoretical Manual, Programme's Manual*. NASA 1970.
6. Schrem, E. *A Short Description of ASKA*. ASKA UM 215, JSD-Stuttgart 1975.
7. Fenves, S.J. *STRESS: A User's Manual*. MIT Press, Cambridge, Mass., 1965.
8. Wilson, E.L. *SOLID SAP, a Static Analysis Program for Three-Dimensional Solid Structure*. Report UC - SESM 71-19, University of California, Berkeley.
9. Kiusalaas, J. Reddy, G.B. *DESAP 1 - A Structural Design Program with Stress and Displacement Constraints*. NASA CR 2794, 1977.

10. Kiusalaas, J.  
Reddy, G.B. *DESAP 2 - A Structural Design Program with Stress and Buckling Constraints*. NASA CR 2797, 1977 - Part II.
11. Dainora, J. *An Evaluation of the STARDYNE System*. Numerical and Computer Methods in Structural Mechanics 211-217. Ac. Press, London 1973.
12. Santini, P. *Soppressione dell'effetto POGO sul vettore ARIANE*. Rapporto ESA 1976.
13. Barboni, R. *Evaluation of Natural Frequencies of SPOT BEAM n 4 Antenna*. Rapporto SELENIA 1974.
14. Felici, G. *Indagine sul comportamento dinamico delle antenne del satellite OTS*. Rapporto SELENIA 1974.
15. Istituto Tecnologia  
Aerospaziale *Dynamic Model of SIRIO Satellite*. Roma, November 1975.
16. Morelli, G. *Coupled Analysis of SIRIO Satellite*. 17° Convegno Tecnico e Scientifico sullo spazio Roma, March 1977.



| CONFIGURATION   | NOTE   | $f_{test}$ | $f_{teorico}$ |
|---|--|------------|---------------|
|    | <p>SHF PLATFORM +<br/>CONE + ABM +<br/>MAIN LOID<br/>PLATFORM<br/>+ 2512 + TEST<br/>ADAPTER</p> <p>1st LONGITUDINAL<br/>MODE</p> | 68 Hz      | 66,9 Hz       |
|  | <p>"</p> <p>1st LATERAL<br/>MODE</p>   | 21 Hz      | 21,4 Hz       |

Figure 2



INPUT 1 g LATERAL

| <u>SYMB.</u> | <u>NODE</u> | <u>REMARK</u> |
|--------------|-------------|---------------|
| o            | 8.8         | ABM           |
| □            | 6.0         | M.L.P.        |
| △            | 1           | SHF ANTENNA   |

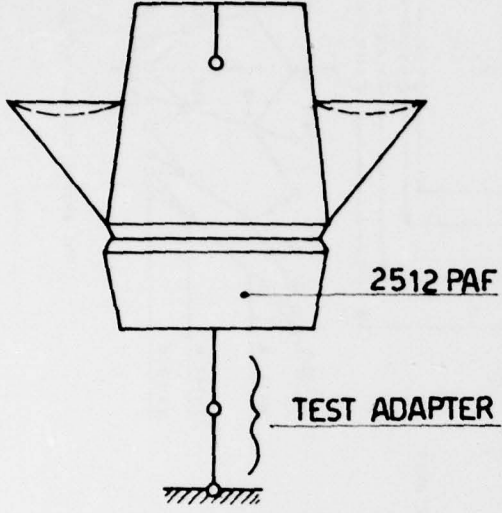
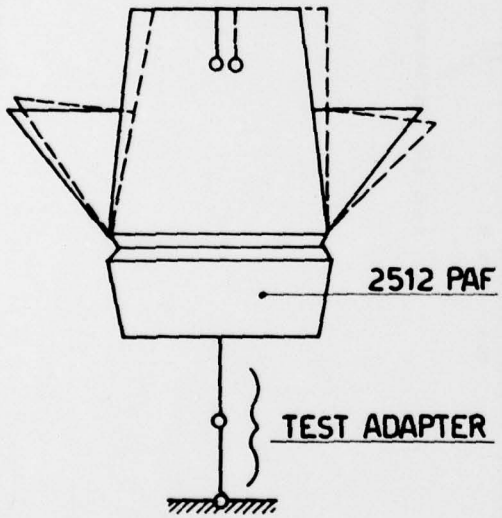
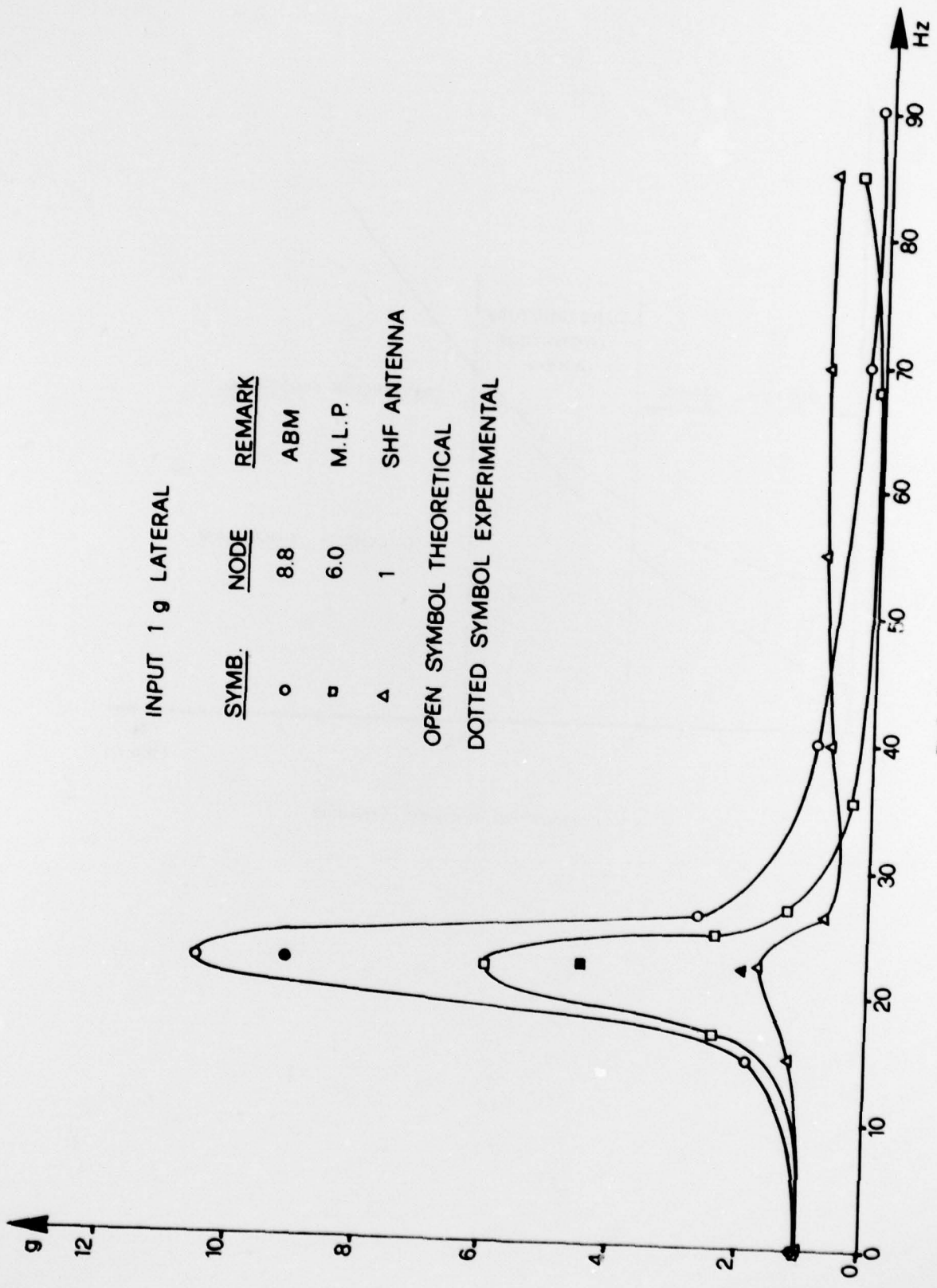
OPEN SYMBOL THEORETICAL  
 DOTTED SYMBOL EXPERIMENTAL

Fig. 3 Dynamic response

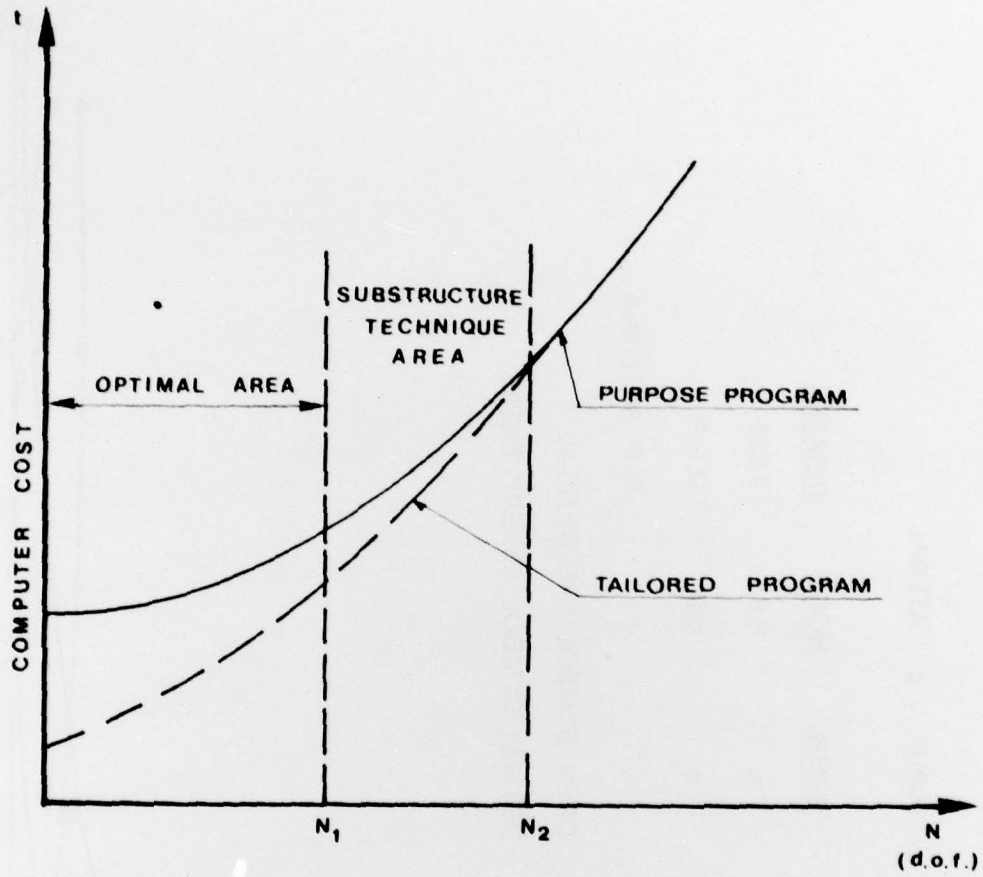

Fig.4 Computer cost vs degrees of freedom

INPUT DATA

MAIN PROGRAM

SUBSTRUCTURE  
OUTPUT/INPUT

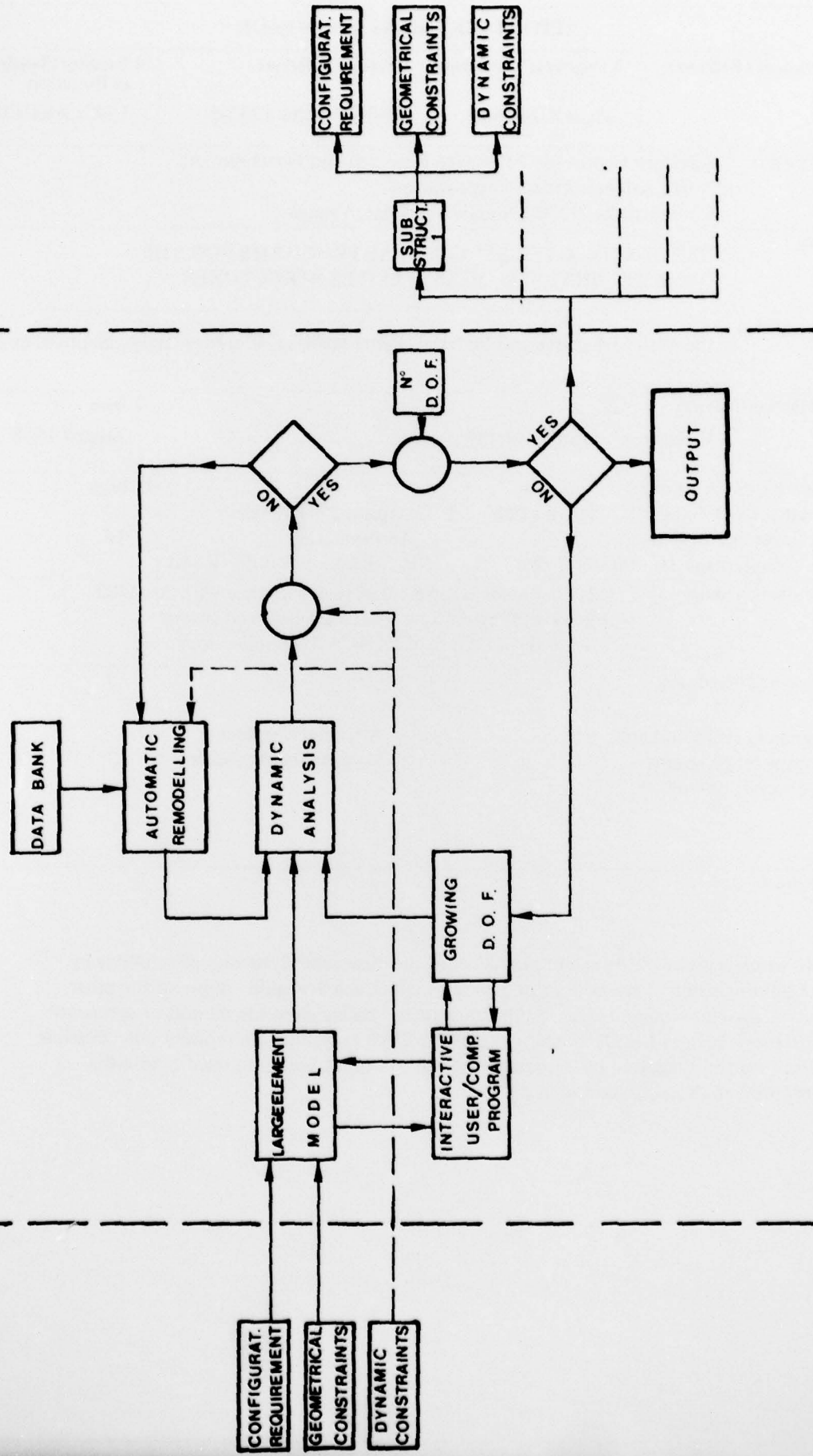

Fig.5 Flow diagram of dynamic analysis program

**REPORT DOCUMENTATION PAGE**

|                                      |  |  |   |                             |                       |                   |                     |                     |  |
|--------------------------------------|--|--|---|-----------------------------|-----------------------|-------------------|---------------------|---------------------|--|
| <b>1. Recipient's Reference</b>      | <b>2. Originator's Reference</b>   | <b>3. Further Reference</b>  | <b>4. Security Classification of Document</b> |                             |                       |                   |                     |                     |  |
|                                      | AGARD-R-680  | ISBN 92-835-1335-5   | UNCLASSIFIED                                  |                             |                       |                   |                     |                     |  |
| <b>5. Originator</b>                 | Advisory Group for Aerospace Research and Development<br>North Atlantic Treaty Organization<br>7 rue Ancelle, 92200 Neuilly sur Seine, France  |  |   |                             |                       |                   |                     |                     |  |
| <b>6. Title</b>                      | USE OF COMPUTER STRUCTURAL PROGRAMS FOR THE<br>DYNAMIC ANALYSIS OF SATELLITES STRUCTURES   |  |   |                             |                       |                   |                     |                     |  |
| <b>7. Presented at</b>               | the 47th Structures and Materials Panel Meeting, Florence, Italy – September 1978.   |  |   |                             |                       |                   |                     |                     |  |
| <b>8. Author(s)/Editor(s)</b>        | R. Barboni* and G. Morelli†  |  | <b>9. Date</b><br>August 1979                 |                             |                       |                   |                     |                     |  |
| <b>10. Author's/Editor's Address</b> | * Istituto di Tecnologia Aerospaziale<br>Università di Roma<br>V. Eudossiana 16 – 00184 Roma   | † Compagnia Nazionale<br>Aerospaziale<br>Via Salaria km 9.300 – Roma | <b>11. Pages</b><br>16                        |                             |                       |                   |                     |                     |  |
| <b>12. Distribution Statement</b>    | This document is distributed in accordance with AGARD policies and regulations, which are outlined on the Outside Back Covers of all AGARD publications.   |  |   |                             |                       |                   |                     |                     |  |
| <b>13. Keywords/Descriptors</b>      | <table border="0"> <tr> <td>Dynamic structural analysis</td> <td>Artificial satellites</td> </tr> <tr> <td>Computer programs</td> <td>Mathematical models</td> </tr> <tr> <td>Spacecraft antennas</td> <td></td> </tr> </table>  |  |   | Dynamic structural analysis | Artificial satellites | Computer programs | Mathematical models | Spacecraft antennas |  |
| Dynamic structural analysis          | Artificial satellites  |  |   |                             |                       |                   |                     |                     |  |
| Computer programs                    | Mathematical models  |  |   |                             |                       |                   |                     |                     |  |
| Spacecraft antennas                  |  |  |   |                             |                       |                   |                     |                     |  |
| <b>14. Abstract</b>                  | <p>↘ Attention is given to the essential aspects of the structural dynamics of satellites by considering some of the computer programs which are available. Some of the most critical problems encountered by the authors in making dynamic models of aerospace structures, such as the OTS antennas and the SIRIO satellite, are pointed out. Possible future trends, suggested by experience of the computer programs used in satellite structural analysis, are considered.</p> <p align="center">↙</p> |  |   |                             |                       |                   |                     |                     |  |

|   |   |   |   |
|---|---|---|---|
| <p>AGARD Report No.680<br/>Advisory Group for Aerospace Research and Development, NATO<br/><b>USE OF COMPUTER STRUCTURAL PROGRAMS FOR THE DYNAMIC ANALYSIS OF SATELLITES STRUCTURES</b><br/>by R.Barboni and G.Morelli<br/>Published August 1979<br/>16 pages</p> <p>Attention is given to the essential aspects of the structural dynamics of satellites by considering some of the computer programs which are available. Some of the most critical problems encountered by the authors in making dynamic models of aerospace structures, such as the OTS antennas and the SIRIO satellite, are pointed</p> <p>P.T.O.</p> | <p>AGARD-R-680</p> <p>Dynamic structural analysis<br/>Computer programs<br/>Spacecraft antennas<br/>Artificial satellites<br/>Mathematical models</p> | <p>AGARD Report No.680<br/>Advisory Group for Aerospace Research and Development, NATO<br/><b>USE OF COMPUTER STRUCTURAL PROGRAMS FOR THE DYNAMIC ANALYSIS OF SATELLITES STRUCTURES</b><br/>by R.Barboni and G.Morelli<br/>Published August 1979<br/>16 pages</p> <p>Attention is given to the essential aspects of the structural dynamics of satellites by considering some of the computer programs which are available. Some of the most critical problems encountered by the authors in making dynamic models of aerospace structures, such as the OTS antennas and the SIRIO satellite, are pointed</p> <p>P.T.O.</p> | <p>AGARD-R-680</p> <p>Dynamic structural analysis<br/>Computer programs<br/>Spacecraft antennas<br/>Artificial satellites<br/>Mathematical models</p> |
| <p>AGARD Report No.680<br/>Advisory Group for Aerospace Research and Development, NATO<br/><b>USE OF COMPUTER STRUCTURAL PROGRAMS FOR THE DYNAMIC ANALYSIS OF SATELLITES STRUCTURES</b><br/>by R.Barboni and G.Morelli<br/>Published August 1979<br/>16 pages</p> <p>Attention is given to the essential aspects of the structural dynamics of satellites by considering some of the computer programs which are available. Some of the most critical problems encountered by the authors in making dynamic models of aerospace structures, such as the OTS antennas and the SIRIO satellite, are pointed</p> <p>P.T.O.</p> | <p>AGARD-R-680</p> <p>Dyanmic structural analysis<br/>Computer programs<br/>Spacecraft antennas<br/>Artificial satellites<br/>Mathematical models</p> | <p>AGARD Report No.680<br/>Advisory Group for Aerospace Research and Development, NATO<br/><b>USE OF COMPUTER STRUCTURAL PROGRAMS FOR THE DYNAMIC ANALYSIS OF SATELLITES STRUCTURES</b><br/>by R.Barboni and G.Morelli<br/>Published August 1979<br/>16 pages</p> <p>Attention is given to the essential aspects of the structural dynamics of satellites by considering some of the computer programs which are available. Some of the most critical problems encountered by the authors in making dynamic models of aerospace structures, such as the OTS antennas and the SIRIO satellite, are pointed</p> <p>P.T.O.</p> | <p>AGARD-R-680</p> <p>Dynamic structural analysis<br/>Computer programs<br/>Spacecraft antennas<br/>Artificial satellites<br/>Mathematical models</p> |

|   |   |
|---|---|
| <p>out. Possible future trends, suggested by experience of the computer programs used in satellite structural analysis, are considered.</p> <p>Papers presented at the 47th Structures and Materials Panel Meeting, Florence, Italy – September 1978.</p> <p>ISBN 92-835-1335-5</p> | <p>out. Possible future trends, suggested by experience of the computer programs used in satellite structural analysis, are considered.</p> <p>Papers presented at the 47th Structures and Materials Panel Meeting, Florence, Italy – September 1978.</p> <p>ISBN 92-835-1335-5</p> |
| <p>out. Possible future trends, suggested by experience of the computer programs used in satellite structural analysis, are considered.</p> <p>Papers presented at the 47th Structures and Materials Panel Meeting, Florence, Italy – September 1978.</p> <p>ISBN 92-835-1335-5</p> | <p>out. Possible future trends, suggested by experience of the computer programs used in satellite structural analysis, are considered.</p> <p>Papers presented at the 47th Structures and Materials Panel Meeting, Florence, Italy – September 1978.</p> <p>ISBN 92-835-1335-5</p> |

B 367  
4

**AGARD**

NATO  OTAN

7 RUE ANCELLE · 92200 NEUILLY-SUR-SEINE  
FRANCE

Telephone 745.08.10 · Telex 610176

**DISTRIBUTION OF UNCLASSIFIED  
AGARD PUBLICATIONS**

AGARD does NOT hold stocks of AGARD publications at the above address for general distribution. Initial distribution of AGARD publications is made to AGARD Member Nations through the following National Distribution Centres. Further copies are sometimes available from these Centres, but if not may be purchased in Microfiche or Photocopy form from the Purchase Agencies listed below.

NATIONAL DISTRIBUTION CENTRES

**BELGIUM**

Coordonnateur AGARD - VSL  
Etat-Major de la Force Aérienne  
Quartier Reine Elisabeth  
Rue d'Evere, 1140 Bruxelles

**CANADA**

Defence Scientific Information Service  
Department of National Defence  
Ottawa, Ontario K1A 0Z2

**DENMARK**

Danish Defence Research Board  
Østerbrogades Kaserne  
Copenhagen Ø

**FRANCE**

O.N.E.R.A. (Direction)  
29 Avenue de la Division Leclerc  
92 Châtillon sous Bagneux

**GERMANY**

Zentralstelle für Luft- und Raumfahrt-  
dokumentation und -information  
c/o Fachinformationszentrum Energie,  
Physik, Mathematik GmbH  
Kernforschungszentrum  
7514 Eggenstein-Leopoldshafen 2

**GREECE**

Hellenic Air Force General Staff  
Research and Development Directorate  
Holargos, Athens, Greece

**ICELAND**

Director of Aviation  
c/o Flugrad  
Reykjavik

**UNITED STATES**

National Aeronautics and Space Administration (NASA)  
Langley Field, Virginia 23365  
Attn: Report Distribution and Storage Unit

THE UNITED STATES NATIONAL DISTRIBUTION CENTRE (NASA) DOES NOT HOLD STOCKS OF AGARD PUBLICATIONS, AND APPLICATIONS FOR COPIES SHOULD BE MADE DIRECT TO THE NATIONAL TECHNICAL INFORMATION SERVICE (NTIS) AT THE ADDRESS BELOW.

PURCHASE AGENCIES

*Microfiche or Photocopy*

National Technical  
Information Service (NTIS)  
5285 Port Royal Road  
Springfield  
Virginia 22161, USA

*Microfiche*

Space Documentation Service  
European Space Agency  
10, rue Mario Nikis  
75015 Paris, France

*Microfiche*

Technology Reports  
Centre (DTI)  
Station Square House  
St. Mary Cray  
Orpington, Kent BR5 3RF  
England

Requests for microfiche or photocopies of AGARD documents should include the AGARD serial number, title, author or editor, and publication date. Requests to NTIS should include the NASA accession report number. Full bibliographical references and abstracts of AGARD publications are given in the following journals:

Scientific and Technical Aerospace Reports (STAR)  
published by NASA Scientific and Technical  
Information Facility  
Post Office Box 8757  
Baltimore/Washington International Airport  
Maryland 21240, USA

Government Reports Announcements (GRA)  
published by the National Technical  
Information Services, Springfield  
Virginia 22161, USA



Printed by Technical Editing and Reproduction Ltd  
Harford House, 7-9 Charlotte St, London W1P 1HD

ISBN 92-835-1335-5