

AD-A074 731

POLAR RESEARCH LAB INC SANTA BARBARA CALIF

F/G 20/1

ARCTIC RESEARCH IN ENVIRONMENTAL ACOUSTICS (AREA) TECHNICAL REP--ETC(U)

JUL 79 B M BUCK, S P BURKE, J O ANDERSON

N00014-79-C-0042

UNCLASSIFIED

PRL-TR-8

NL

| OF |  
ADA  
074731



END  
DATE  
FILMED  
11 -79  
DDC

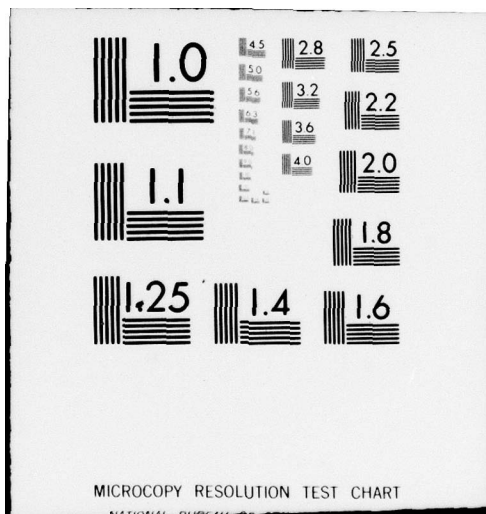

AD A 074731

LEVEL

12

DDC  
RECEIVED  
AUG 21 1979  
RESERVE

PRL

DDC FILE COPY

This document has been approved for public release and sale; its distribution is unlimited.

POLAR RESEARCH LABORATORY, INCORPORATED  
123 Santa Barbara Street - Santa Barbara, California 93101



79 08 00

12

DDC  
RECEIVED  
AUG 21 1979  
C

6 Arctic Research in Environmental Acoustics  
(AREA)  
Technical Report <sup>Number</sup> No. 8;  
ARCTIC LEAD-AIRDROP DATA BUOY

10

Beaumont B. M. /BUCK, P. /BURKE and J. O. /ANDERSON

Samuel

John

9

Technical rept.,

Polar Research Laboratory, Inc.  
123 Santa Barbara Street  
Santa Barbara, CA. 93101

12 22

14

11

PRL-TR-18  
25 July 1979

This work was sponsored by  
Code 461, Office of Naval Research  
Contract No. N00014-79-C-0042

15

This document has been approved for public release and sale; its distribution is unlimited.

391 013

mt

Accession For	
NTIS GRA&I	<input checked="" type="checkbox"/>
DDC TAB	<input type="checkbox"/>
Unannounced	<input type="checkbox"/>
Justification	
By _____	
Distribution/	
Availability Codes	
Dist.	Avail and/or special
A	

ARCTIC LEAD-AIRDROP DATA BUOY (U)

BEAUMONT M. BUCK

SAMUEL P. BURKE

and

JOHN O. ANDERSON

POLAR RESEARCH LABORATORY, INC.  
 123 SANTA BARBARA STREET  
 SANTA BARBARA, CA 93101

ABSTRACT

Arctic data buoys are capable of data collection that is impractical of accomplishment by manned-station techniques primarily because of high logistics costs. These costs differentials can be even further reduced by buoy paradrop. Size, weight, and power limit the usefulness of such devices, but their most serious drawback has been automatic deployment of sensors under the ice. A new concept which employs a data buoy that is designed for air drop into open water leads of opportunity, is powered for up to a year life, and uses the new TIROS-N ARGOS system for position and data recovery offers promise in solving these problems. The configuration of the buoy, called "LAD" (Lead Air Droppable), is described along with the results of preliminary Arctic field tests of the concept. Because of the limited nature of those tests, viability of the approach is not yet established, and additional trials are planned for spring 1980.

INTRODUCTION

There are several primary ways of obtaining oceanographic data in ice covered seas: icebreakers, submarines, manned ice stations, and unmanned automatic data buoys. Each method has advantages and limitations. This paper describes a new technique in unmanned automatic data buoys.

The main advantages of Arctic data buoys are the relative economy of deploying and operating them and the fact that they are the only technique suitable for long-term observations taken at various places over a wide region at or nearly at the same time (i.e., "synoptically"). Arctic data buoys can be designed for deployment either by ski-equipped aircraft landings on the ice or by paradrop. Both techniques have been used with considerable success since 1975, (references 1, 2, 3, 4). The primary disadvantage of Arctic data buoys is the limited sophistication that can be built into an unmanned, expendable package, and their consequent lack of flexibility. And, oceanographic sensors deployed below the ice have the further disadvantage of requiring an aircraft landing and manned deployment. Since such landings are limited to the spring months, March, April and May, when the ice surface and light conditions are suitable, the all-season capability afforded by paradrop would be highly desirable.

The Air-Deployed Random Access Measurement System (ADRAMS) data buoy (Figure 1) is an airdrop buoy designed for atmospheric pressure and air temperature measurements. Over 60 of these units have been used quite successfully since 1975, (reference 4). However, ADRAMS (which telemeters its position and data through polar-orbiting scientific satellites, NIMBUS-6 and TIROS-N) is an ice surface-resting buoy and contains no provision for deploying sensors beneath the ice.

Figure 1  
AIR-DEPLOYABLE RANDOM ACCESS MEASUREMENT SYSTEM  
(ADRAMS)

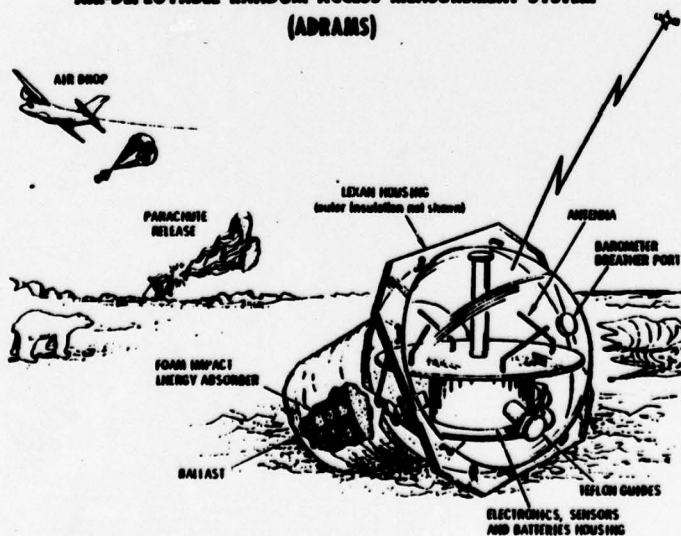

The new technique described in this paper offers promise of eliminating the disadvantages described above. Since the technique uses paradrops for deployment, it offers an all-season installation capability. In addition, the technique provides for deploying sensors beneath the ice without aircraft landing or manned deployment. However, further tests are required to verify the promise of the technique.

#### DESIGN CONSIDERATIONS

Sensors, such as hydrophones, can be deployed in the water column beneath the ice from an air dropped device in two ways. The sensor can carry its own capability of drilling a hole through the ice and deploy

the sensor(s) through that hole, or it can be dropped in an open water lead. As firm believers in Stout's Laws (1. "Simplify. What you don't put on can't give you no trouble." 2. "Add more lightness.") we have chosen the latter simpler approach. Most Arctic data buoys working through TIROS-N are long-term devices, battered for lives of approximately one year, during which time the ice can drift 500 nautical miles or more. Pinpoint geographical accuracy for the installation of such systems therefore is not necessary. We have observed in hundreds of hours of flying over Arctic Ocean ice, that open water or thin-ice-covered leads are prevalent, especially after a windstorm, although a quantitative assessment is not available. Since small leads are much more common than large ones, an accurate airdrop technique is important in the design of a data buoy measurement for lead deployment. This in turn dictates very low dropping altitudes for the installing aircraft.

Even though small leads are more common, it is better to drop a buoy into a large lead from the viewpoint of buoy longevity. The ice is more apt to translate before (and if) the thick ice floes come back together to form a pressure ridge. If it does translate, the irregular edges of the break will form interstice sections that will refreeze and slowly grow thicker (and stronger). A data buoy in those areas has much greater life expectancy than one dropped in a small lead that later turns into a pressure ridge.

A further design consideration is that a refrozen lead is most vulnerable to pressure when it is young and therefore apt to break up in its early stages. A buoy designed with rugged portions in the interface would have a greater chance of survival. Also, a rounded bottom on the surface float would cause the buoy to pop up during the surface refreezing process and/or during pressure to avoid damage, in the same way the design of Nansen's research ship FRAM was intended.

Even when the ice breaks up on the surface of a lead, there is usually little activity 20 or 30 feet (6.1-9.1m) below. If the sensitive parts of a buoy (i.e., electronics and batteries) can be suspended at that level and only the bare minimum (in this case a small antenna that must be used for telemetry to the satellite) is included in the interface, the chances of survival would be considerably increased. Just how rugged the antenna and its housing must be is open to conjecture and depends on the ice break-up conditions it will encounter. Of course, before freeze-up of the lead, the housing will also have to provide flotation for the whole system-including deployed sensors.

A TIROS-N telemetry system was chosen as most suitable, since it is economical, low-power, and, at 401 MHz, requires only a small antenna. The TIROS-N ARGOS system, allows about 2000-4000 data bits per day and, with in-buoy processing, this amount can be useful for certain Arctic scientific data collection tasks. Moreover, the ARGOS system gives

daily position of the data buoy (to about 1 Km accuracy)-an important consideration in the constantly moving Arctic ice pack. The ability of 2000-4000 bits per day to achieve significant results in the Arctic is best exemplified by the results of NIMBUS-6 RAMS Arctic data buoys (Figure 2) which got by with only 256 data bits per day, yet very considerably increased our knowledge of underice ambient noise (references 3, 5, 6, 7, 8). In fact, the order of magnitude increase in data made possible by ARGOS led us to believe that an arctic data buoy capable of obtaining long-range acoustic propagation data is feasible.

Figure 2  
**SYNOPTIC RAMS (SYNRAMS)  
 ARCTIC DATA BUOY**

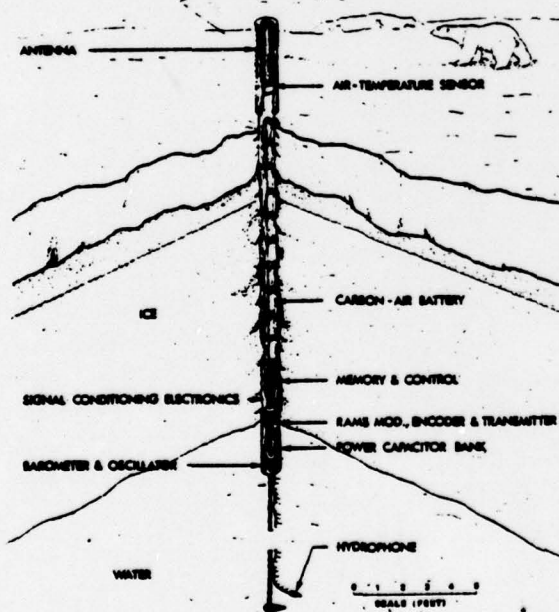

For the 1979 design concept tests, however, NIMBUS-6 RAMS was chosen for buoy telemetry because of the present high cost of processed TIROS-N ARGOS data. (This situation is expected to change within a year for U.S. scientific users.)

Therefore, assuming that a significantly useful data buoy could be made into a small, ruggedized package for airdrop at reasonable cost, longevity is the remaining prime question. It is extremely difficult, if not impossible, to model the expected life of a buoy dropped into a lead at this time. Despite the greater longevity on ice than in a lead, even a buoy dropped onto thick ice and employing an ice drill for deploying sensors is not immune to destruction by leads and pressure ridges, which can occur anywhere

at any time in the Arctic. Figure 3 illustrates what can happen even to manned camps. In essence, it is probably cost-effective to deploy in leads if the buoy and its sensors can be economically produced. If not, considerably more size, sophistication, and consequent cost must be cranked in, and the device ice-dropped. Because of the unknowns in predicting longevity, our approach was to build and test it. Only our Arctic experience and intuition tells us it is practical.

#### DESIGN DETAILS

Thus far in this paper our discussion has dealt with automatic data buoys in general terms. This section takes a more specific look at the design details of the new concept in data buoys,

Figure 3  
Pressure Ridge Destroying Ice Station



#### General Configuration

The design concept of the Lead-Airdrop Data Buoy (LAD) is shown in Figure 4. The surface buoy containing the antenna housing is made up of two hemispheres, the bottom of spun aluminum and the top of RF-transparent polycarbonate. Inside this 22-inch (56 cm) sphere is a 401 MHz modified canted turnstile antenna. A doubly-armored and jacketed coax cable 20 feet (6.1m) long connects the antenna in the sphere to a submerged cylindrical pressure housing containing thionol chloride ("inorganic") lithium batteries and the electronics. Below this is 80 feet (24.4m) of three-conductor Kevlar cable with woven "hair" fairing to reduce strumming and a 25-pound weight at the bottom. The hydrophone is at 100 feet (30.5m) below sea level and decoupled from the cable with a three-foot (.9m) faired line. It is made near-neutrally buoyant by a three-foot (.9m) long multistrand polypropylene "tail", which also serves to dampen vertical oscillations of the phone.

The overall concept provides for a fully deployed buoy with only a ruggedized antenna in the interface and a tough, protected cable to the electronics in the expected ice-active zone. The design allows maximum protection to the buoy in a lead-refreeze situation and also in the case of thin ice break-up of the lead. Even if a major pressure ridge develops in the vicinity of the buoy, its chance of survival is fairly good because of the ruggedness of the three top units (sphere, cable, and pressure housing).

Figure 4  
LEAD AIR DROP BUOY (LAD)

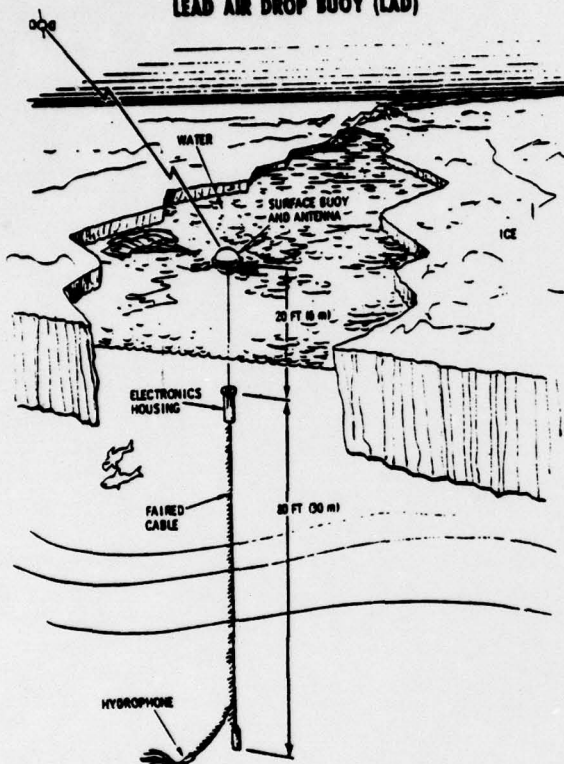
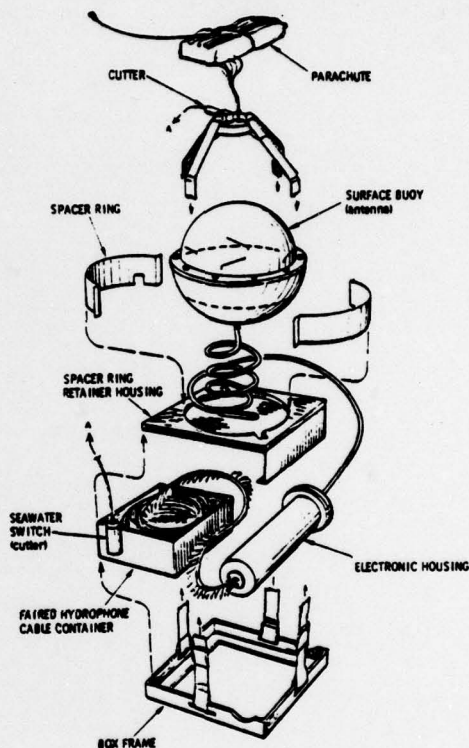

Figure 5  
LEAD AIR DROP BUOY (LAD) COMPONENTS



#### Configuration For Airdrop

Figure 5 is an exploded view of LAD components. The antenna sphere is nestled in a sectioned break-away box of wood and aluminum which contains the antenna cable, pressure housing, and the hydrophone and its cable. The cables are coiled into this box. Straps of nylon webbing attached to the box lead to a ring of nylon strap atop the sphere. This ring passes through a squib-actuated guillotine cutter as does the shroud line for a 32-foot paraform parachute. The cutter is activated upon striking the water by a set of batteries and a salt water switch closure. The cutter releases both the parachute and the four hold-down straps, allowing the box to fall apart and the hydrophone and pressure housing to deploy beneath the sphere. Figure 6 is a photograph of a buoy awaiting loading into the drop aircraft.

Figure 7 shows a LAD buoy readied for dropping out of the cargo door of the Tri Turbo-3 Arctic aircraft, and Figure 8 shows the buoy deployed in a large polynya. On a low-altitude pass by the aircraft the buoy top is easily observed and the absence of the dark colored

Figure 6  
Buoy Awaiting Loading in Aircraft



Figure 7  
LAD Ready for Airdrop

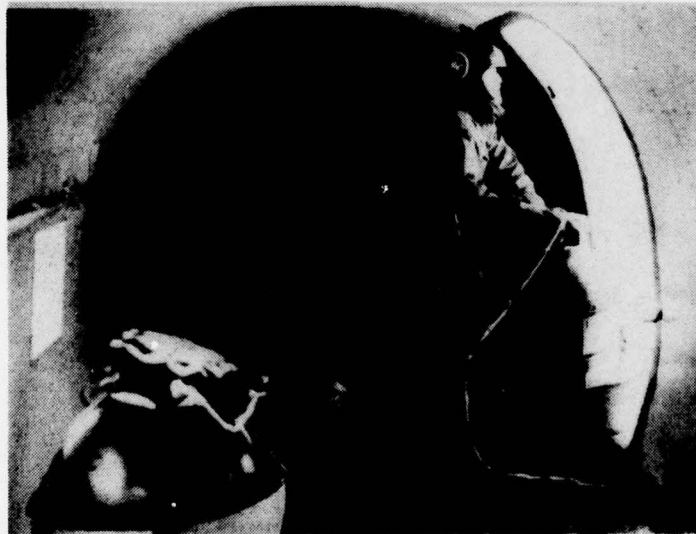

hold-down straps indicates deployment of the bottom units. A TIROS test set installed in the aircraft indicates operability of the satellite telemetry. Figure 9 is the Tri Turbo-3 Arctic aircraft used to deploy the buoys. This aircraft has extremely long range and can install buoys anywhere in the Arctic Ocean from Barrow, Alaska or Nord, Greenland.



Figure 8  
LAD Buoy Deployed  
in Polynya

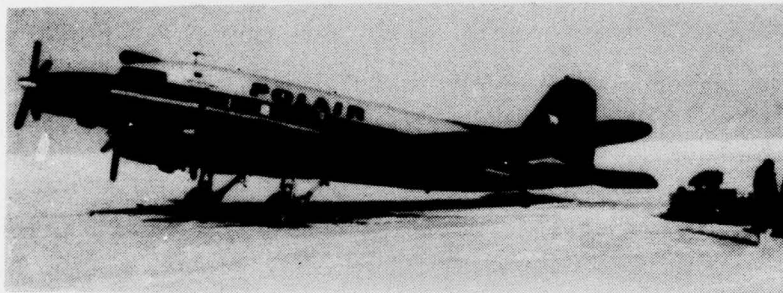

Figure 9  
Tri Turbo-3  
Aircraft Used for  
LAD Drops

#### In-Buoy Processing

LAD is the first known attempt to include complete in-buoy processing of received shot signals for propagation loss with on-board electronics. This was necessary because of the limited data capacity of polar-orbiting scientific satellites (the Arctic Ocean latitudes are too high to "see" geostationary satellites having more capacity) and the consequent impossibility of sending uncompressed shot signal data. The aim was to develop a long-life buoy devoted primarily to propagation data in the first few weeks and systematic sampling of ambient noise levels and ice drift in the rest of its life. This was predicated on the fact that the same aircraft used to deploy the buoys would normally be available during a typical spring experiment to drop MK61 and MK82 SUS. The time period available for receiving those signals is limited by the practical consideration of battery power. The system must be "on" continuously for shot reception whereas for ambient noise sampling it is normally "off" and only turned "on" at the synoptic weather times every three hours for short sampling. Therefore, in the latter mode the unit

consumes very little power and the lithium battery supply can power it for up to a year. The telemetry electronics is "on" continuously and transmits data stored in memory for one second each minute. To further conserve power during the shot reception period, the buoy is timed to come "on" for a prearranged four-hour period daily during which the aircraft (or manned camps) can drop shots. During the remaining 20 hours the buoy makes three-hourly ambient noise samples, omitting only the one during the four-hour shot period. Shot data are given telemetry priority during the two-week period.

The basic LAD system may be described (see block diagram, Figure 10) as a hydrophone generating signals for a set of analog processing electronics as controlled by COSMAC microprocessor through a series of I/O electronics. The processor continuously operates under a program that is resident in an EPROM. The program is controlled by interrupts received from a timing generator that are generated once each minute to maintain the system timing. All of these electronics, with the exception of the hydrophone and its cable and the RAMS transmitting antenna, are located in the electronic housing.

Figure 10  
**LEAD AIR DROP (LAD) SCHEMATIC**

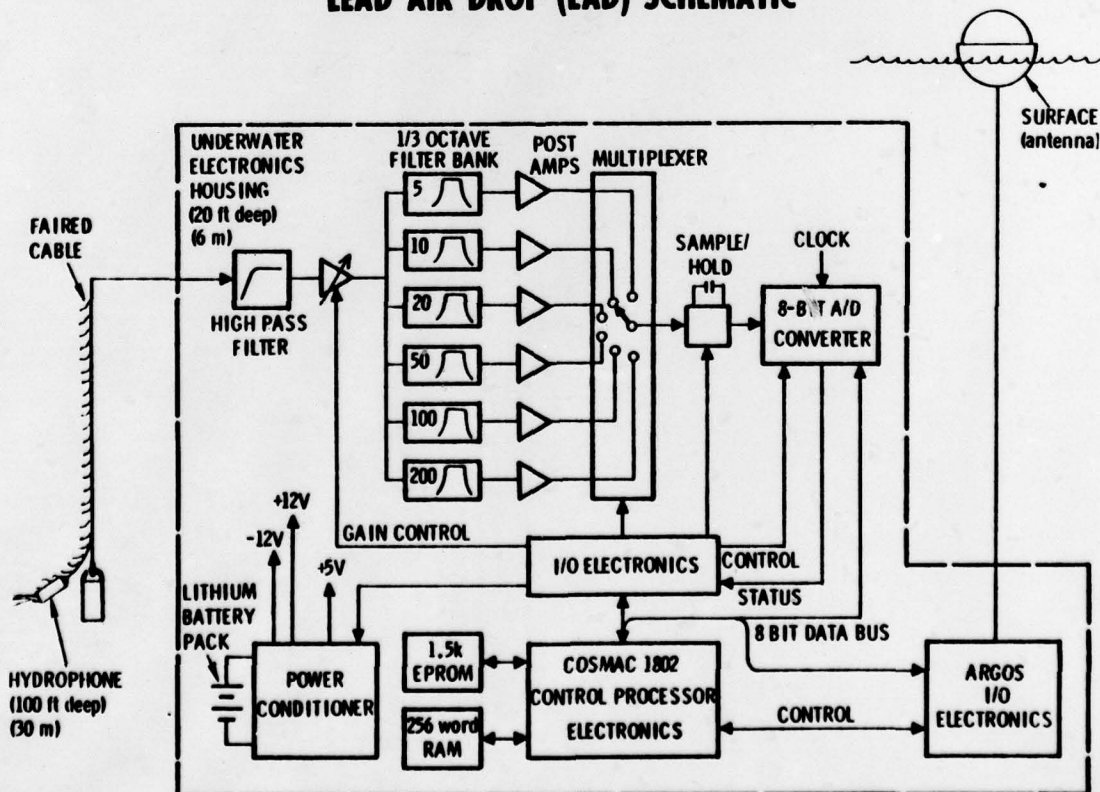

The hydrophone consists of an acceleration-cancelling double bender ceramic element that is connected to a low noise field effect transistor preamplifier. The combination has noise performance well below the Wenz "minimum sea noise". The hydrophone is encapsulated in polyurethane material and connected to the end of the 100-foot faired Kevlar cable.

The signals from the hydrophone preamplifier output are fed up the cable into the electronic housing to the input of a high pass filter. The filter has a 0.7 Hz breakpoint with a two-pole roll off. It is placed at this point in the system to attenuate the extremely low frequency signals that are sometimes generated by hydrophone "bounce" effects caused by water currents in the area. The output of the filter feeds an analog postamplifier that has its gain controlled by a COSMAC microprocessor, depending on the operating state of the system. The output of the postamplifier feeds a bank of six one-third octave filters of center frequencies: 5, 10, 20, 50, 100, and 200 Hz. The active filters incorporate three pole-pair networks, stagger-tuned to give a flat passband response. The outputs of the filters route to separate post-amplifiers. The gains of these postamplifiers have been set using information about the expected spectrum of an input transient signal from a shot. This is chosen so that the resultant output signal is within a range of zero to five volts and fall within the dynamic range of the eight-bit analog to digital converter. Before the signal arrives at the A/D converter it first must pass through a full-wave precision rectifier so that it falls in the zero to five volt range since the A/D converter does not respond to negative voltages. The outputs of the full-wave rectifiers are fed to a "sample and hold" stage via a CMOS multiplexer (16-channel) which is controlled by the microprocessor. The output of the "sample and hold" is fed directly to the eight-bit CMOS analog-to-digital converter which converts the input signal to an eight-bit word with a conversion time of approximately 100 microseconds.

The block in Figure 10 titled "ARGOS I/O Electronics" is a PRL 401 MHz phase-modulated ARGOS transmitter. The microprocessor generates the required timing signals and data stream requirements for the ARGOS polar orbiting satellite system.

Power for the system is provided by a bank of four, 22 amp-hour, double D size inorganic lithium cells. The total capacity of the bank is approximately 88 amp-hours at about 14 volts. The normal system drain for the LAD system in an ambient noise mode is 16 milliamps, which provides for about 223 days of operation. When the LAD buoy is in a mode where it is responding to acoustic transients (i.e., the "shot mode") the power drain increases significantly-to about 95 milliamps. The test system used this spring was programmed in this mode for four hours every two days for a 10-day period. During this period it used up approximately 3.8 amp-hours, or a little over four percent of the total capacity of the primary battery. In the ambient noise mode of

operation the LAD buoy real time clock counts down a three-hour counter to the "synoptic weather times" (midnight, 0300, 0600 ...). When the counter is counted down to zero the three-hour sample interval begins, the power comes up, and the data is sampled once the transients have subsided in the system. The data are accumulated in six 24-bit accumulators for a 15-second period. At the end of the three-hour sample period, the accumulator contents are reformed into "a floating point binary word" which is an eight-bit word representing the sound pressure level over that 15-second period for one of the six one-third octave filters. The resulting eight-bit words are stored in a 24-hour memory with the newest sample replacing the oldest sample in that memory. Each sample word consists of two, 32-bit groups. In each group there are six eight-bit words corresponding to the noise samples and two eight-bit words referring to the time of day and buoy reference data.

Three of the four 1979-test LAD buoys (numbers 2, 4, and 5)\* were programmed so they would go into the shot mode once every 48 hours and remain in this mode for a four-hour period to allow time for ice stations and/or aircraft to drop charges for reception by the buoy. With the buoy in this mode the processor samples blocks of data every 15 seconds and looks at the output from the 20 Hz third octave filter to make a "detection" decision. Each output sample of that filter is tested against a threshold set by the processor on the basis of the highest sample during the previous 15-second sample interval. The threshold used is twice the maximum previous sample. If the particular sample exceeds that threshold at any time, a number of events take place. First, the noise for the previous 15-second period is saved in memory, and immediately the energy for the following 15 seconds is accumulated in the 24-bit accumulators. Each 15-second noise sample is squared through the use of a software "look up table" by the microprocessor. The resulting square is truncated to eight bits and then stored in the 24-bit accumulator. At the end of the 15-second period the data are reformed into a floating point binary and put into memory as an eight-bit word corresponding to one of the six one-third octave channels. During the four-hour acoustic transient mode period as many as 12 events can be stored in memory by the system. At the end of the twelfth event, if the four-hour period is not over, the system automatically shuts down and goes into a normal ambient noise mode. During the next 24 hours these data are transmitted to the polar orbiting satellite.

## RESULTS

After preliminary sea tests in the Santa Barbara Channel, a test version of LAD was taken to the Chukchi Sea in October 1978 in the USCG icebreaker NORTHWIND. This unit was deployed by dropping it without a parachute off the fantail of the icebreaker in an open water lead in

\* LAD-3 did not have the shot processor.

first-year ice on 27 October at position  $72^{\circ}45'N$   $170^{\circ}W$ . The buoy-processing electronics were still in laboratory development at that time so that only a dummy hydrophone was used and the telemetry was NIMBUS-6 RAMS. At this writing (the end of June 1979) this unit (LAD-1) was still operational-having lived eight months in the Arctic environment, during which time the buoy has drifted 294 nautical miles. This was encouraging but as it is only a sample size of one, it hardly proves the concept.

Four more LADs were constructed, along with complete electronics packages (except LAD-3), and made ready for trials during the ONR Arctic East-79 experiment in the Eurasian Basin. NIMBUS-6 RAMS electronics were used via TIROS-N for these early trials. Basing out of Nord, Greenland, the Tri Turbo-3 deployed by airdrop LADs 2, 3, and 4 at the positions shown in Figure 11. LAD-5 was a non-airdrop version installed by landing on shorefast ice near the Marginal Sea Ice Zone-Atlantic at the location also shown in Figure 11.\*

There have been very few ice station drifts in the Eurasian Basin from which drift patterns of the pack can be assessed for the area.



Figure 11

Yet, pack drift patterns are an important parameter, necessary for the proper placement of manned ice camps and automatic stations. The former are, of necessity, usually short term and only in the spring when flying conditions are good. Data collected in other seasons and in areas too remote for manned camps must be obtained from data buoys. As those stations become more sophisticated and, therefore, most costly, it will be desirable to retrieve them after one, or possibly two complete years of operation. A study of the drifts of the ships FRAM, SEDOV, ice islands, ARLIS II and T3, and North Pole floe stations 1, 5, 7, and 17 indicates that installations on a line from the pole south along about  $60^{\circ}W$  and on a line from the pole south

\* The LADs were not numbered chronologically according to drops.

along about 90°E made in April of one year will drift south through the Greenland-Svalbard Strait and be within reach of a helicopter or ski-equipped aircraft based out of Nord during April of the following year. The installation positions of LADs 2, 3, and 4 were selected to test this premise.

LAD 2, dropped at 87°N/60°W into a sizable lead covered by grease ice, went in very smoothly and deployed its sensor but was never received by the satellite-cause of failure unknown. LAD-4 was aimed from an altitude of 300 feet (91m) at a medium-sized floe at the North Pole with an experienced jumpmaster timing the deployment. A smoke flare dropped first to gauge the wind was a dud so that the wind direction could only be judged by observing ripples on the open water of the lead. The wind was misjudged and the buoy landed on ice about 10 feet from the edge of the lead. However, the unit worked well with the satellite and we are receiving ambient noise data via the RAMS system that strongly indicate the buoy later deployed itself into the water (the edges of leads can be quite active). LAD-3, installed in a small lead at 86°N/75°E was dropped perfectly in the center of the open water after making four 250 foot (76m) passes to drop smoke flares and nylon streamers so that the mistake of LAD-4 would not be repeated. LAD-3 was configured as an ambient-noise-only buoy without the shot processor. As of this writing (in late June 1979) LAD-3 was transmitting good ambient noise data through NIMBUS-6. LAD-5, installed by landing on shorefast ice and drilling a hole at 80°N/15°W failed to communicate with the satellite.

Failure of two out of five LAD NIMBUS-6 RAMS transmitters is extraordinarily high compared with the past performance of other small NIMBUS data buoys (for example, on the basis of 2148 buoy days, the Mean Time to Failure at 0.75 confidence level is 548 days per buoy-reference.9). The novel packaging of the electronics in the pressure housing could hold the key to the failures, and we are investigating this possibility. The shock of airdrop on the new package would also cause or contribute to the cause of failure; however, one of the two failures was not airdropped. The two failures can probably be attributed to the tight schedule for the Arctic East-79 in readying the buoys. Obviously, more laboratory environmental testing is required. This testing is being accomplished. More time for burn-in before the next Arctic test opportunity (East Arctic-80) should also help.

Of the three LADs configured for propagation processing (2, 4, and 5), two failed, as mentioned, to communicate with NIMBUS-6, and the third was misdropped onto the ice and remained there during the shot tests. Therefore, none were available for shot reception testing. As a backup, analog tape recordings of shots were made from a manned station for both regular laboratory-received energy flux density analysis and playback for comparison purposes into the LAD processor.

It is too early in the development of LAD to say whether or not the concept is viable. Such knowledge will come only after several more LADs are deployed to determine whether their attained lives justify the cost of construction and air deployment. Assuming that a reasonable average life is possible, the concept holds considerable promise for gaining environmental acoustic data in sections of the Arctic Ocean and Marginal Sea Ice Zones during seasons of the Arctic year where this is not presently possible. If so, data will be obtained that are attainable in no other way at anywhere near the cost of LAD.

#### FUTURE PLANS

The three LADs that are operating through NIMBUS-6 will be watched and their attained life spans noted. Ice drift from the two in the Eurasian Basin will be of particular interest for planning future LADs and other types of ice station deployments in this new area. The three-hour ambient noise samples, the only such data extant for the Eurasian Basin, will be compiled, analyzed, and compared with similar prior data in other Arctic areas. Several new LAD buoys will be constructed, using TIROS-N ARGOS for telemetry instead of NIMBUS-6 RAMS, burned in and air-drop deployed in the spring of 1980 as part of ONR's Arctic East-80 program, thereby gaining additional life expectancy data as well as environmental acoustic data. After that experiment we should be able to ascertain whether the concept of lead-deployment is cost effective for research, and, possibly, operational applications.

#### ACKNOWLEDGEMENT

This work was sponsored by Arctic Programs (Code 461) Office of Naval Research as part of Contract N00014-79-C-0042.

## REFERENCES

1. "Two Recently Developed Arctic Data Buoys," B. M. Buck, E. G. Kerut, W. P. Brown, S. P. Burke; 3rd International Conference on Port and Ocean Engineering under Arctic Conditions Proceedings, University of Alaska, 11-15 August 1975 (U).
2. "Arctic Environmental Buoy," W. P. Brown and E. G. Kerut; OCEAN 75 IEEE and MTS Conference Proceedings, 22-25 September 1976 (U).
3. "The SYNRAMS Ice Station," S. P. Burke and B. M. Buck; OCEAN 75 IEEE and MTS Conference Proceedings, 22-25 September 1975 (AREA Technical Report No. 1, PRL TR004, 1 January 1976) (U).
4. "Air Droppable RAMS (ADRAMS) Buoy," W. P. Brown and E. G. Kerut; OCEAN 76 IEEE and MTS Conference Proceedings, 13-15 September 1976 (U).
5. "Arctic Noise Measurement Experiment Using NIMBUS-6 Data Buoys (U)," C. R. Greene and B. M. Buck; U.S. Navy Journal of Underwater Acoustics, Vol. 27, No. 4, October 1977.
6. "Springtime Low Frequency Acoustics Measurements in the Northern Marginal Ice Zone-Atlantic (U)," B. M. Buck and C. R. Greene; PRL TR11, March 1978.
7. "Influence of Atmospheric Pressure Gradient on Under-ice Ambient Noise (U)," C. R. Greene and B. M. Buck; U.S. Navy Journal of Underwater Acoustics, Vol. 28, No. 4, October 1978.
8. "Shallow Water Ambient Noise in the Arctic Ocean (U)," C. R. Greene and B. M. Buck; prepared for submission to the U.S. Navy Journal of Underwater Acoustics (1979).
9. NOAA Data Buoy Office SOW TMD, Encl. 6 "Applicable Documents" RFP 7-038002 dated 11 February 1977 (U).

DISTRIBUTION LIST

ADDRESSEE

NO. OF COPIES

Administrative Contracting  
Officer  
Defense Contract Administration  
Services Management Area, Oxnard  
500 Esplande Drive, Suite 990  
Oxnard, CA. 93030  
DODAAD Code: So519A

1

Office of Naval Research (461)  
800 North Quincy Street  
Arlington, VA 22217  
ATTN: Mr. Charles A. Luther  
DODAAD Code: N00014

1

Director  
Naval Research Laboratory  
ATTN: Code 2627  
Washington, D. C. 20375  
DODAAD Code: N00173

6

Defense Documentation Center  
Building 5  
Cameron Station  
Alexandria, VA 22314  
DODAAD Code: S47031

12

Office of Naval Research  
Branch Office  
1030 East Green Street  
Pasadena, CA 91106  
DODAAD Code: N62887

1

Dr. Kenneth L. Hunkins  
Lamont-Doherty Geological Observatory  
of Columbia University  
Palisades, New York 10964

1

Dr. Waldo K. Lyon, Director  
Arctic Submarine Laboratory  
Naval Ocean Systems Center  
San Diego, California 92132

DISTRIBUTION LIST

<u>ADDRESSEE</u>	<u>NO. OF COPIES</u>
Dr. Norbert Untersteiner Office of Naval Research Code 400P Arlington, Virginia 22217	1
Dr. Robert Francois Applied Physics Laboratory University of Washinton Seattle, Washington 98195	1
Mr. Andreas Heiberg University of Washington Polar Science Center 4057 Roosevelt Way, NE Seattle, Washington 98105	1
Dr. Miles McPhee U.S. Army Cold Regions Research and Engineering Laboratory Hanover, New Hampshire 03755	1
Dr. Robert Paquette U.S. Naval Postgraduate School Department of Oceanography Monterey, California 93940	1
Professor Theodore D. Foster Center for Coastal Marine Studies Applied Sciences Building University of California Santa Cruz, California 95064	1
Dr. Knut Aagaard University of Washington Department of Oceanography Seattle, Washington, 98105	1
Dr. Ira Dyer, Director Department of Ocean Engineering Massachusetts Institute of Technology Cambridge, Massachusetts 02139	1
Mr. Steve Ackley U.S. Army Cold Regions Research and Engineering Laboratory Hanover, New Hampshire 03755	1

DISTRIBUTION LIST

ADDRESSEE

NO. OF COPIES

Mr. Meyer M. Kleinerman  
Project Manager for Arctic ASW  
Naval Surface Weapons Center  
Code WU-401  
White Oak, Maryland 20910

1



Unclassified

SECURITY CLASSIFICATION OF THIS PAGE(When Data Entered)

these problems. The configuration of the buoy, called "LAD" (Lead Air Droppable), is described along with the results of preliminary Arctic field tests of the concept. Because of the limited nature of those tests, viability of the approach is not yet established, and additional trials are planned for Spring 1980.

Unclassified

SECURITY CLASSIFICATION OF THIS PAGE(When Data Entered)