

AD-A074 894

ARINC RESEARCH CORP ANNAPOLIS MD

F/G 10/2

OPERATING MANUAL FOR THE DYNAMIC TEST SET (DTS) FOR THE LOW VOL--ETC(U)

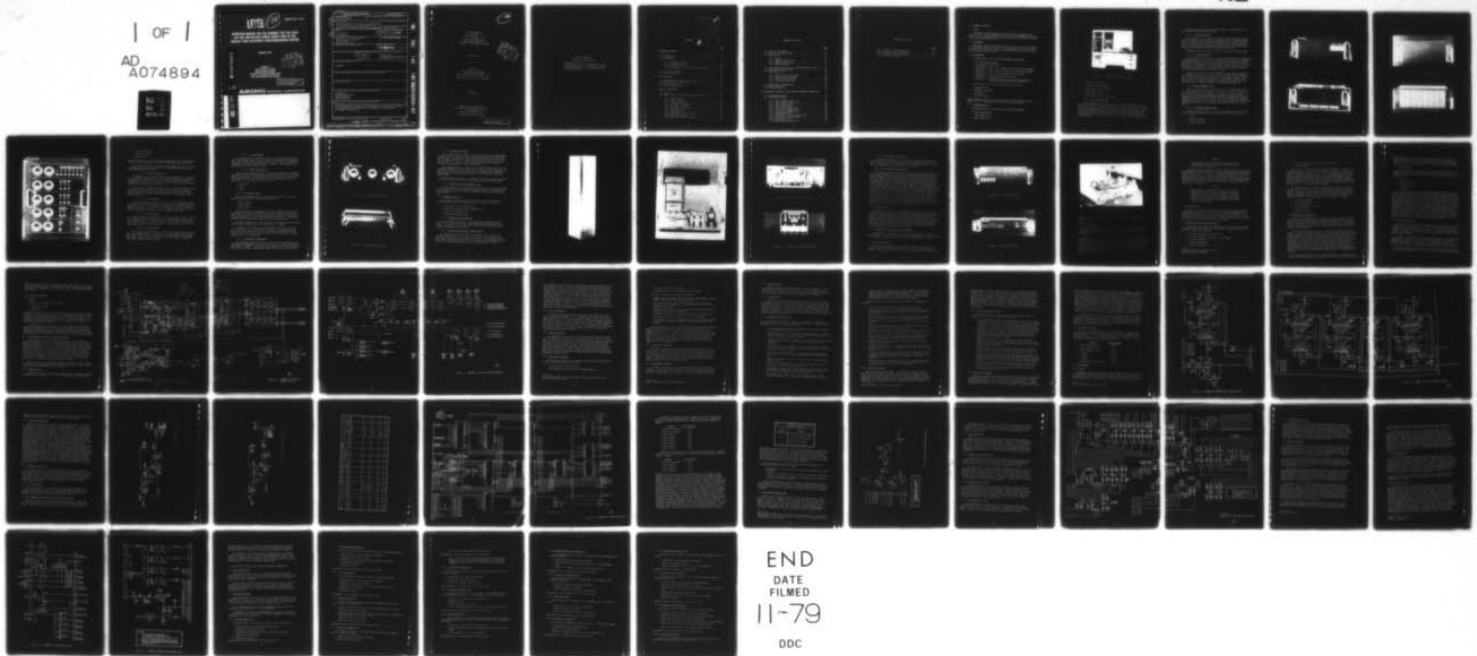
SEP 79 J R WHITE

F09603-78-G-4125

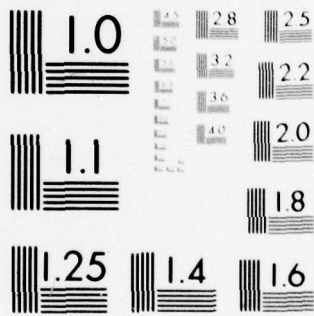
NL

UNCLASSIFIED 1552-11-2-2015

| OF |  
AD  
A074894



END  
DATE  
FILMED  
11-79  
DDC



MICROCOPY RESOLUTION TEST CHART  
NATIONAL BUREAU OF STANDARDS-1963-A

**LEVEL**

10

Publication 1552-11-2-2015

**OPERATING MANUAL FOR THE DYNAMIC TEST SET (DTS)  
FOR THE LOW VOLTAGE POWER SUPPLY PART OF THE  
AN/ALQ-119(V) ELECTRONIC COUNTERMEASURES SYSTEM**

September 1979

DDC  
RECEIVED  
OCT 11 1979  
E

AD A 074894

Prepared for  
UNITED STATES AIR FORCE  
WARNER ROBINS ALC/PPZBB  
ROBINS AIR FORCE BASE, GEORGIA 31098  
under Contract F09603-78-G-4125-0002

This document has been approved  
for public release and sale; its  
distribution is unlimited.

**ARINC** RESEARCH CORPORATION

DDC FILE COPY

REPORT DOCUMENTATION PAGE		READ INSTRUCTIONS BEFORE COMPLETING FORM
1. REPORT NUMBER 1552-11-2-2015	2. GOVT ACCESSION NO.	3. RECIPIENT'S CATALOG NUMBER
4. TITLE (and Subtitle) Operating manual for the dynamic test set (DTS) for the low voltage power supply part of the AN/ALQ-119(V) electronic countermeasures system	5. TYPE OF REPORT & PERIOD COVERED	
7. AUTHOR(s) J. R. White	6. PERFORMING ORG. REPORT NUMBER 1552-11-2-2015	8. CONTRACT OR GRANT NUMBER(s) F09603-78-G-4125-0002
9. PERFORMING ORGANIZATION NAME AND ADDRESS ARINC Research Corporation 2551 Riva Road Annapolis, Md. 21401	10. PROGRAM ELEMENT, PROJECT, TASK AREA & WORK UNIT NUMBERS	
11. CONTROLLING OFFICE NAME AND ADDRESS	12. REPORT DATE September 1979	13. NUMBER OF PAGES 57p.
14. MONITORING AGENCY NAME & ADDRESS (if different from Controlling Office) 12 63p.	15. SECURITY CLASS. (of this report) Unclassified	
15a. DECLASSIFICATION/DOWNGRADING SCHEDULE		
16. DISTRIBUTION STATEMENT (of this Report) Unlimited		
17. DISTRIBUTION STATEMENT (of the abstract entered in Block 20, if different from Report)		
18. SUPPLEMENTARY NOTES		
19. KEY WORDS (Continue on reverse side if necessary and identify by block number) AN/ALQ-119 (V) Countmeasures System Operating Manual Dynamic test set		
20. ABSTRACT (Continue on reverse side if necessary and identify by block number) This manual contains operating instructions for the Dynamic Test Facility (DTF) used for checkout and repair of interchangeable low voltage power supplies P/N 624R629G01 and P/N 634R149G01 of the AN/ALQ 119 (V) Electronic Countermeasures (ECM) Pod.		

440 247

10

OPERATING MANUAL  
FOR THE  
DYNAMIC TEST SET (DTS)  
FOR THE  
LOW VOLTAGE POWER SUPPLY  
PART OF THE AN/ALQ-119(V)  
ELECTRONIC COUNTERMEASURES SYSTEM

D D C  
RECEIVED  
OCT 11 1979  
E

September 1979

Prepared for  
United States Air Force  
Warner Robins ALC/PPZBB  
Robins Air Force Base, Georgia 31098  
under Contract F09603-78-G-4125-0002

by  
J.R. White

ARINC Research Corporation  
a Subsidiary of Aeronautical Radio, Inc.  
2551 Riva Road  
Annapolis, Maryland 21401  
Publication 1552-11-2-2015

This document has been approved  
for public release and sale; its  
distribution is unlimited.

Copyright © 1979

ARINC Research Corporation

Prepared under Contract F09603-78-G-4125-0002,  
which grants to the U.S. Government a license  
to use any material in this publication for  
Government purposes.

Accession For	
NTIS GRA&I	<input checked="" type="checkbox"/>
DDC TAB	<input type="checkbox"/>
Unannounced	<input type="checkbox"/>
Justification	
By _____	
Distribution/ _____	
Availability Codes	
Dist	Avail and/or special
<b>A</b>	

CONTENTS

	<u>Page</u>
1.0 GENERAL INFORMATION . . . . .	1
1.1 Scope . . . . .	1
1.2 Arrangement . . . . .	1
1.3 Descriptions . . . . .	1
1.3.1 Equipment Rack A1 . . . . .	1
1.3.2 Equipment Cabinet A2 . . . . .	10
1.3.3 Test Bench A3 . . . . .	14
1.3.4 Accessory Jigs, Fixtures, and Test Cables . . . . .	14
1.4 Ancillary Equipment . . . . .	14
1.5 Safety Information . . . . .	16
2.0 TEST PHILOSOPHY . . . . .	17
2.1 AN/ALQ-119 Low Voltage Power Supply . . . . .	17
2.2 DTS Monitoring Capabilities . . . . .	18
2.3 Test Procedures . . . . .	19
2.4 DTS Operational Modes . . . . .	19
3.0 THEORY OF OPERATION . . . . .	20
3.1 General . . . . .	20
3.2 Logic Control and Power Distribution Circuits . . . . .	20
3.2.1 ON/OFF Control . . . . .	20
3.2.2 Logic Initiation . . . . .	25
3.2.3 Standby Operation . . . . .	25
3.2.4 Test Mode 1 Operation . . . . .	25
3.2.5 Test Mode 2 Operation . . . . .	26
3.2.6 Test Mode 3 Operation . . . . .	26
3.2.7 Decode Operate . . . . .	27
3.2.8 Current Drives . . . . .	27
3.2.9 OVLD Monitor/Pulse Generator . . . . .	27
3.2.10 Test Table Controls . . . . .	28
3.2.11 Power Distribution Circuits . . . . .	29

CONTENTS (continued)

	<u>Page</u>
3.3 Metering Card A1A3A8 . . . . .	29
3.4 Rms to Dc Converter A1A3A6 . . . . .	30
3.5 Load Circuits . . . . .	30
3.5.1 General . . . . .	30
3.5.2 Positive Load Circuit . . . . .	35
3.5.3 Negative Load Circuit . . . . .	35
3.5.4 Part Association . . . . .	35
3.6 Card Assembly A1A3 Connection and Calibration Circuit . .	35
3.7 Line Monitor Assembly A1A6 . . . . .	42
3.8 Load Panel A1A5 . . . . .	44
3.8.1 Meter Circuit 5-Volt Load . . . . .	44
3.8.2 Metering Circuit A-Load . . . . .	44
3.8.3 Other Metering Circuits . . . . .	44
3.8.4 Load Shorting Circuits . . . . .	47
3.9 Control Panel Assembly A2A4 . . . . .	47
3.10 Power Supply A1A2 . . . . .	48
3.11 Overload Protection . . . . .	48
4.0 INSTALLATION, REMOVAL, AND ASSEMBLY/DISASSEMBLY INSTRUCTIONS .	53
4.1 Moving Instructions . . . . .	53
4.2 Disassembly/Assembly . . . . .	53
4.2.1 Relay Assembly (A1A1) . . . . .	53
4.2.2 Power Supply Assembly A1A2 . . . . .	54
4.2.3 Card Assembly A1A3 . . . . .	54
4.2.4 Blower Assembly A1A4 . . . . .	54
4.2.5 Load Panel Assembly A1A5 . . . . .	54
4.2.6 Line Monitor Assembly A1A6 . . . . .	55
4.2.7 Calibration Assembly A1A7 . . . . .	55
4.2.8 Load Assembly A1A8 . . . . .	55
4.2.9 Transformer Chassis Assembly A1A9 . . . . .	56
4.2.10 Differential Voltmeter A2A1 . . . . .	56
4.2.11 Patch Panel A2A2 . . . . .	56
4.2.12 Oscilloscope Assembly A2A3 . . . . .	56

CONTENTS (continued)

	<u>Page</u>
4.2.13 Control Panel Assembly A2A4 . . . . .	57
4.2.14 Equipment Rack Assembly A1 . . . . .	57
4.2.15 Equipment Cabinet Assembly A2 . . . . .	57
4.2.16 Test Bench Assembly A3 . . . . .	57

## 1.0 GENERAL INFORMATION

### 1.1 Scope

This manual contains operating instructions for the Dynamic Test Facility (DTF) used for checkout and repair of interchangeable low voltage power supplies P/N 624R629G01 and P/N 634R149G01 of the AN/ALQ-119(V) Electronic Countermeasures (ECM) Pod.

### 1.2 Arrangement

The manual describes the Dynamic Test Facility and the test philosophy for the AN/ALQ-119(V) power supply. It also presents the theory of operation and the installation, removal, and assembly/disassembly instructions for the Dynamic Test Set (DTS).

### 1.3 Descriptions

The DTF consists of the following equipment and material:

- The DTF Operating Manual
- The Dynamic Test Set (DTS)
- Supplement A - TP100, Test Procedure for Power Supply 624R629G01
- Supplement B - TP200, Test Procedure for Power Supply 634R149G01
- Supplement C - TP300 Calibration Procedure for the DTS
- Supplement D - TP400 Maintenance for the DTS
- Supplement E - Commercial Manuals for Internal Power Supplies, Oscilloscope, and Differential Voltmeter

The DTS consists of the following four assembly groups:

- Equipment Rack A1
- Equipment Cabinet A2
- Test Bench A3
- Accessory Group

These equipment groups are discussed in order in the following sections. Figure 1-1 is an illustration of the DTS and its accessories.

#### 1.3.1 Equipment Rack A1

The equipment rack A1 consists of the following assemblies:

- Relay assembly A1A1
- Power supply A1A2
- Card assembly A1A3

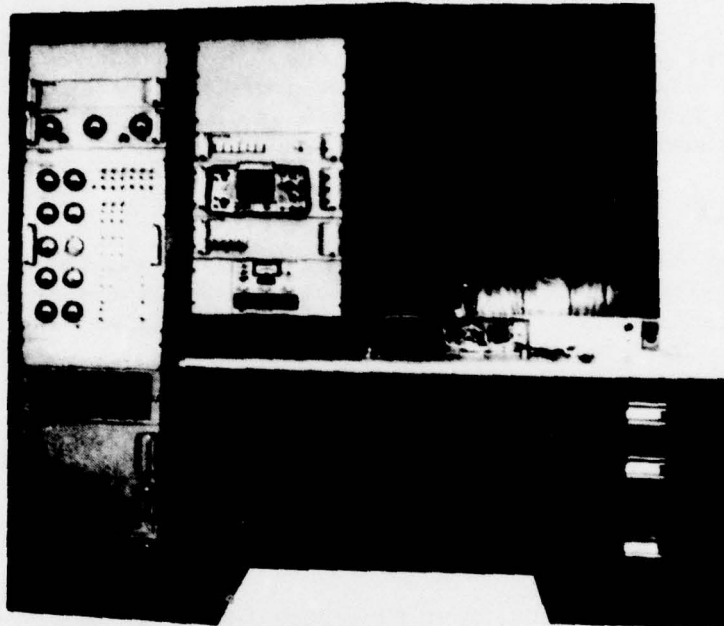


Figure 1-1. OVERALL VIEW WITH ACCESSORIES

- Blower assembly A1A4
- Load panel assembly A1A5
- Line monitor assembly A1A6
- Calibration assembly A1A7
- Load assembly A1A8
- Transformer chassis assembly A1A9

1.3.1.1 Relay Assembly A1A1

Relay assembly A1A1 (see Figure 1-2) is the power-switching and junction box for the DTS. Primary power sources (115/208 volts, 400 Hz, 3 phase; 28 volts dc; and 115 volts, 60 Hz, 1 phase) originate on the input connector plate and are routed through circuit breakers to the relay assembly. The front panel contains circuit breakers for all primary sources. All relay contacts are rated for 10 amperes. When the main power switch located on the control panel is OFF, only 28 volts dc is present at the output of the relay assembly.

Distribution of power from the relay assembly is controlled by the logic circuits located on assembly A1A3.

#### 1.3.1.2 Power Supply A1A2

Power supply A1A2 (see Figure 1-3) consists of four commercial power units furnishing  $\pm 5$ -volt and  $\pm 12$ -volt internal sources. The frame assembly is also a commercial unit designed for mounting of the individual power units. On the back panel is a 24-volt regulator for driving relays and a 15-volt regulator for excitation of the logic devices. The primary power source for the regulators on the back panel is 28 volts dc.

An integral blower assembly is provided for cooling the power supply.

#### 1.3.1.3 Card Assembly A1A3

Card assembly A1A3 (see Figure 1-4) contains the logic board assemblies, ac root mean square (ac-rms) to dc converters, meter amplifiers, and meter calibration circuits. Test points for checking all internally regulated voltage levels are provided on the calibration chassis. A built-in means of calibration is provided by the internal test selector switches, which connect reference voltages and scaling resistors to the various integrated-circuit (IC) devices and to the metering devices.

The logic portion of the circuit provides for test mode selection and for automatic operation of the current sensors, relays, and load-enable circuits in accordance with specific test requirements. Cabinet interlock and personnel safety interlock circuits are also provided by the logic. Provisions are included for expanding the capabilities of the DTS logic system to support additional types of low voltage power supplies.

#### 1.3.1.4 Blower Assembly A1A4

Blower assembly A1A4 (see Figure 1-5) provides a commercial blower for cooling the cold plate assembly located in test bench A3 and for cooling the solid-state load assembly A1A8. Blower air is routed through the cold plate assembly and returned to assembly A1 through ducting. The returned air is then routed through the A1A8 load assembly and exhausted through the cabinet top into the room. Air enters through the grillwork located on the front panel. A reusable dust filter behind the grill may be detached for cleaning by releasing two thumb screws located on the front panel.

#### 1.3.1.5 Load Panel Assembly A1A5

Load panel assembly A1A5 (see Figure 1-6) provides load control and current and voltage metering for the following power supply sections:

- 5-volt
- A-Load (+12 Volts)
- B-Load (+28 Volts)

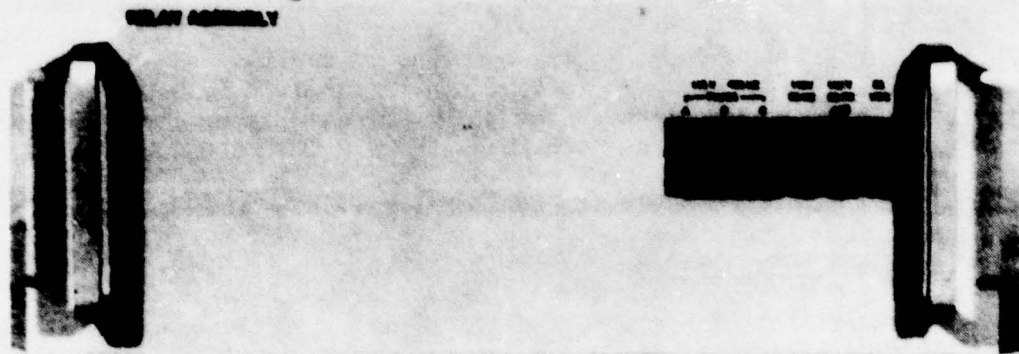


Figure 1-2. RELAY ASSEMBLY A1A1

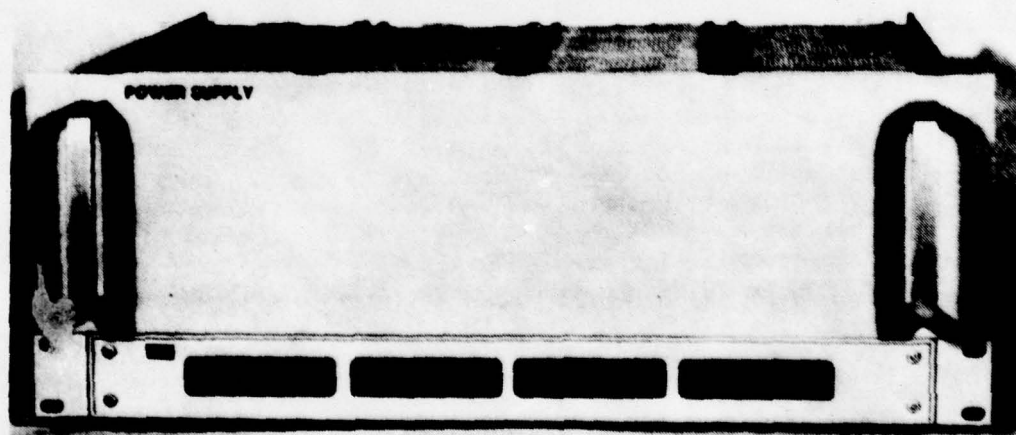


Figure 1-3. POWER SUPPLY ASSEMBLY A1A2

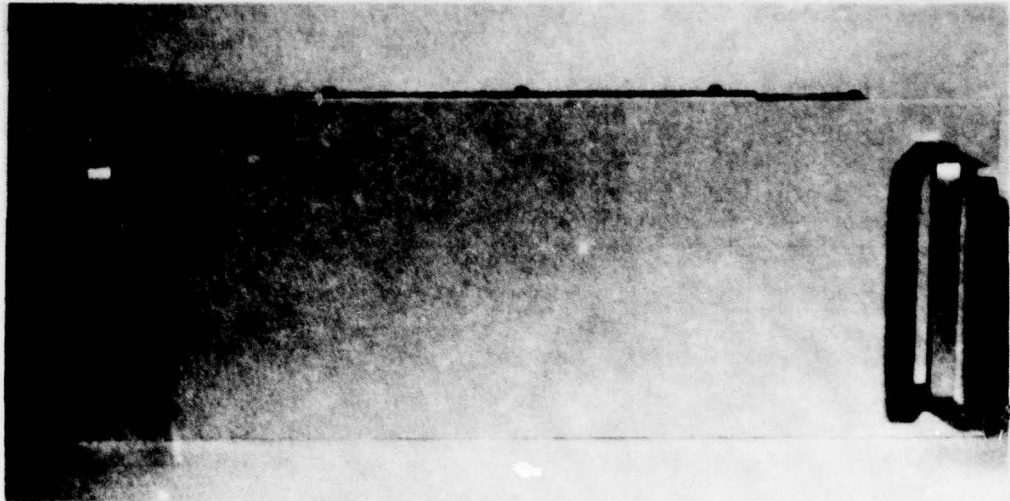


Figure 1-4. CARD ASSEMBLY A1A3

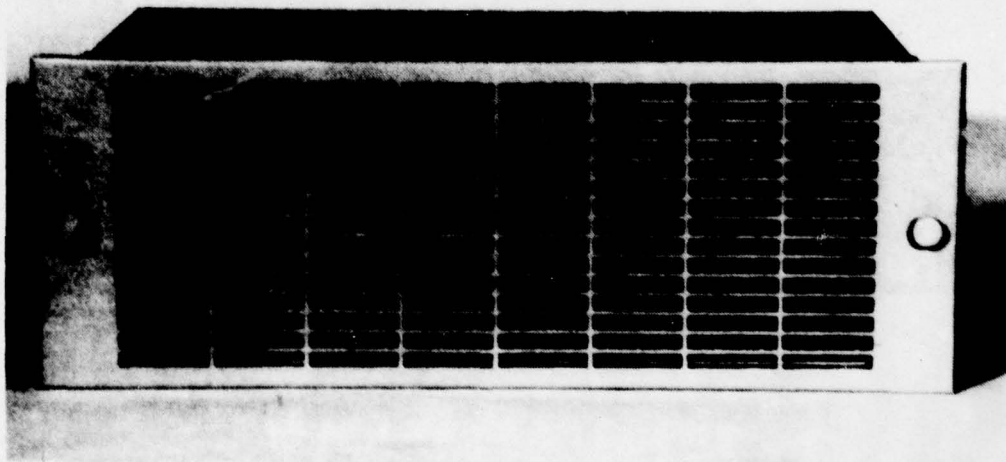


Figure 1-5. BLOWER ASSEMBLY A1A4

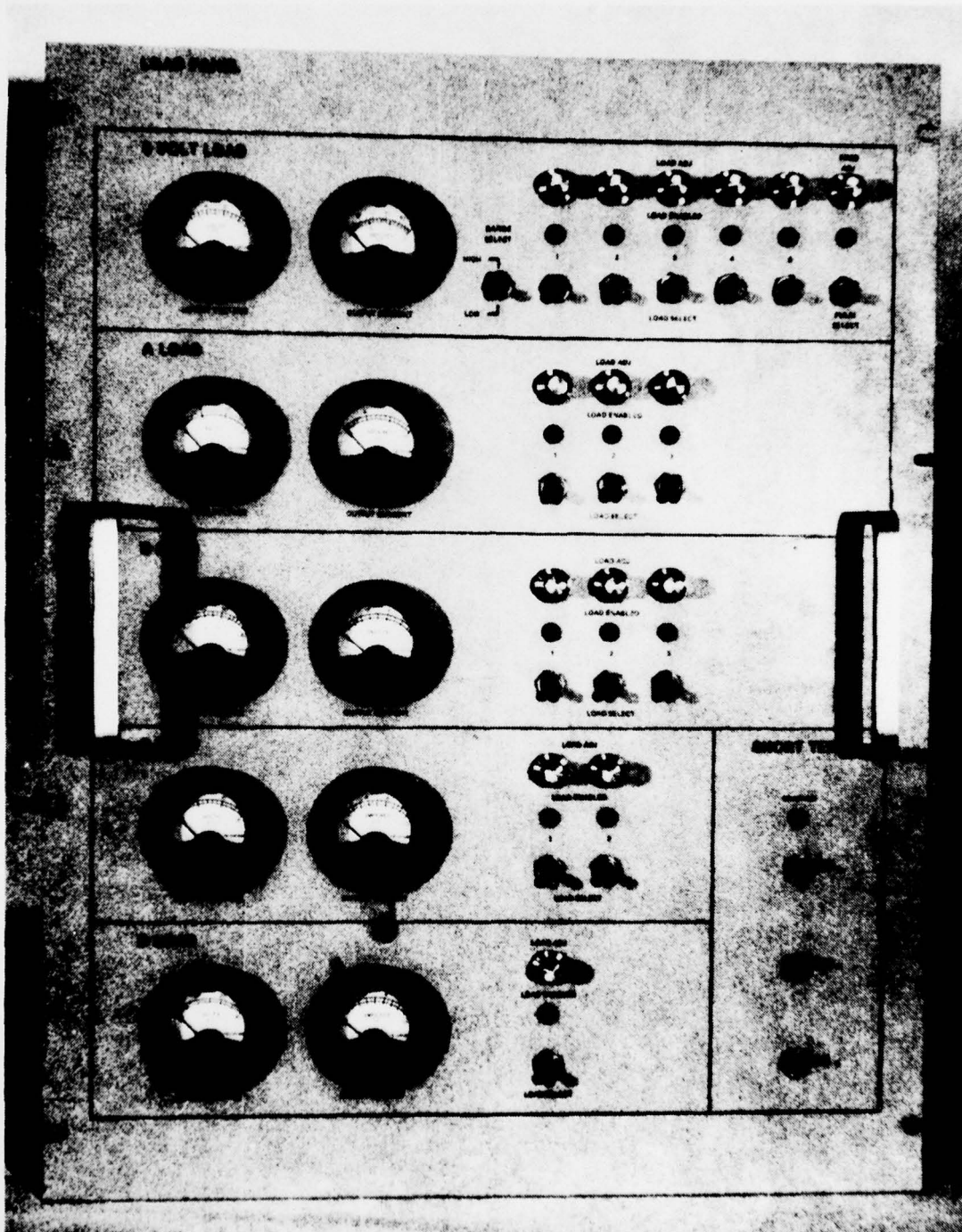


Figure 1-6. LOAD PANEL ASSEMBLY A1A5

- C-Load (-12 Volts)
- D-Load (-20 Volts)
- Short test

Each of these control sections contains panel meters for continuous monitoring of output voltages and currents from the unit under test (UUT).

The control sections are arranged in load-banks, each of which is provided with a load-enable indicator. Only those banks applicable to the test mode selected are enabled.

#### 1.3.1.5.1 5-Volt Load Section

The ammeter in the 5-volt load section is furnished with a low/high current range selector switch. In the low range, the meter is calibrated and scaled for 15 amperes full scale; in the high range, the meter is calibrated and scaled for 50 amperes full scale. Range selection does not interrupt current flowing in the load.

These are five load-bank selections, each of which is capable of load control sufficient to adjust the current from 0 to at least 10 amperes. Switches in each bank allow for sequential application of preset load-current values. A 5-ampere pulse load circuit is also included in the 5-volt load section.

#### 1.3.1.5.2 A-Load Section

The A-load section is applicable only to the  $\pm 12$ -volt supply portion of the UUT. The voltmeter reads 15 volts full scale; the ammeter reads 15 amperes full scale. There are three load-bank circuits, each capable of adjusting the current from 0 to at least 4 amperes. Switches in each bank allow for sequential application of preset load-current values.

#### 1.3.1.5.3 B-Load Section

The B-load section is applicable only to the 28-volt portion of the UUT. The voltmeter reads 50 volts full scale; the ammeter reads 5 amperes full scale. There are three load-bank circuits, each capable of adjusting the load current from 0 to at least 2 amperes. Switches allow for sequential application of preset current values.

#### 1.3.1.5.4 C-Load Section

The C-load section is applicable only to the -12-volt portion of the UUT. The voltmeter reads 15 volts full scale; the ammeter reads 10 amperes full scale. There are two load-bank circuits, each capable of adjusting the current from 0 to at least 3 amperes. Switches allow for sequential application of preset current values.

#### 1.3.1.5.5 D-Load Section

The D-load section is applicable only to the 20-volt portion of the UUT. The voltmeter reads 30 volts full scale; the ammeter reads 1 ampere full scale. There is one load-bank control circuit, which is capable of adjusting the current from 0 to at least 1 ampere. A switch allows for application of a preset current value.

#### 1.3.1.5.6 Short Test Section

The short test section consists of three instantaneous-type switches that activate relays and thereby short the output of the UUT. The shorting operation is inhibited except during Test Mode 2 operation, in which the mode enable indicator is illuminated. The three shorting switches are applicable to the following power supply sections:

- 5-volt load
- A-load
- C-load

#### 1.3.1.6 Line Monitor AlA6

Line monitor assembly AlA6 is illustrated in Figure 1-7. It houses panel meters that monitor the following functions:

- Phase voltage
- Neutral current
- Line current

The phase voltage meter measures the 400-Hz, 3-phase voltage applied to the UUT. The meter is connected ahead of the 400-Hz control relay to permit monitoring of the input phase voltage at all times. A phase-select switch allows any one of the three phases to be selected for voltage monitoring. The voltage monitor reads 0 to 200 volts full scale.

The neutral current meter monitors the true rms neutral current portion of the 400-Hz, 3-phase line; it is scaled for 0 to 3 amperes.

To measure line current, current transformers sense the ac current and a true ac rms to dc converter drives a meter. A switch permits any one of the three 400-Hz input lines to be selected for monitoring; selection does not interrupt the flow of current in the input lines. The meter is scaled for 0 to 3 amperes rms.

#### 1.3.1.7 Calibration Assembly AlA7

The calibration assembly AlA7 (see Figure 1-8) is mounted behind the panel marked CALIBRATION. The calibration controls are accessible when the front panel is removed. They provide coarse adjustment of the solid-state load currents, thereby establishing maximum limits for each load control.



Figure 1-7. LINE MONITOR ASSEMBLY A1A6

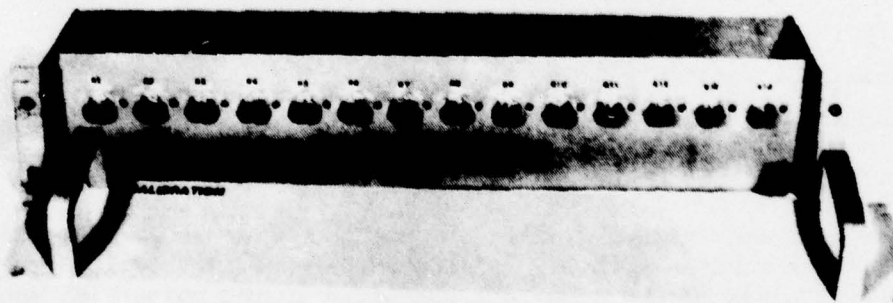


Figure 1-8. CALIBRATION ASSEMBLY A1A7

#### 1.3.1.8 Load Assembly A1A8

Load assembly A1A8 (see Figure 1-9) contains four heat sink assemblies (A1A8A1, etc.) for loading the UUT. Assembly A1A8A1 contains a heat sink and Darlington transistors for loading the 5-volt portion of the UUT from 0 to 50 amperes and other Darlington transistors for loading the +12-volt portion from 0 to 6 amperes. Each Darlington transistor is capable of dissipating approximately 60 watts continuously.

Load assembly A1A8A2 is similar to the A1A8A1 assembly except that the Darlington transistors furnish loads for the -12-volt, 28-volt, and -20-volt portions of the UUT. A 5-volt pulse load is included in this assembly. Drive signals for the Darlington transistors are developed on load panel assembly A1A5.

Two additional heat sinks are installed in the A1A8 assembly for future use. They provide an additional dissipation capability of 1,000 watts.

#### 1.3.1.9 Transformer Chassis Assembly A1A9

The transformer chassis assembly A1A9 contains a variable 3-phase transformer (VARIAC, Registered Trade Name of General Radio), a 3-phase 400-Hz line transformer, and four current transformers to sense line current (see Figure 1-10).

#### 1.3.2 Equipment Cabinet A2

The equipment cabinet assembly A2 consists of the four assemblies listed below and described in Subsections 1.3.2.1 through 1.3.2.4.

- Oscilloscope (scope) assembly A2A3
- Differential voltmeter (DVM) assembly A2A1
- Patch panel assembly A2A2
- Control panel assembly A2A4

##### 1.3.2.1 Oscilloscope Assembly A2A3

The oscilloscope incorporated into oscilloscope assembly A2A3 (see Figure 1-11) is a Tektronix, Inc., model 465M, hereinafter referred to as "scope". Particulars of the scope are contained in the commercial manual provided in Supplement E of the DTF.

##### 1.3.2.2 Differential Voltmeter Assembly A2A1

The differential voltmeter (DVM) incorporated into the differential voltmeter assembly A2A1 (see Figure 1-12) is a John Fluke Company, Inc., model 893A, equipped with a rack panel kit adapter. All precision measurements taken on the UUT use the DVM. Particulars of this instrument are contained in the commercial manual provided in Supplement E of the DTF.



Figure 1-9. LOAD ASSEMBLY A1A8

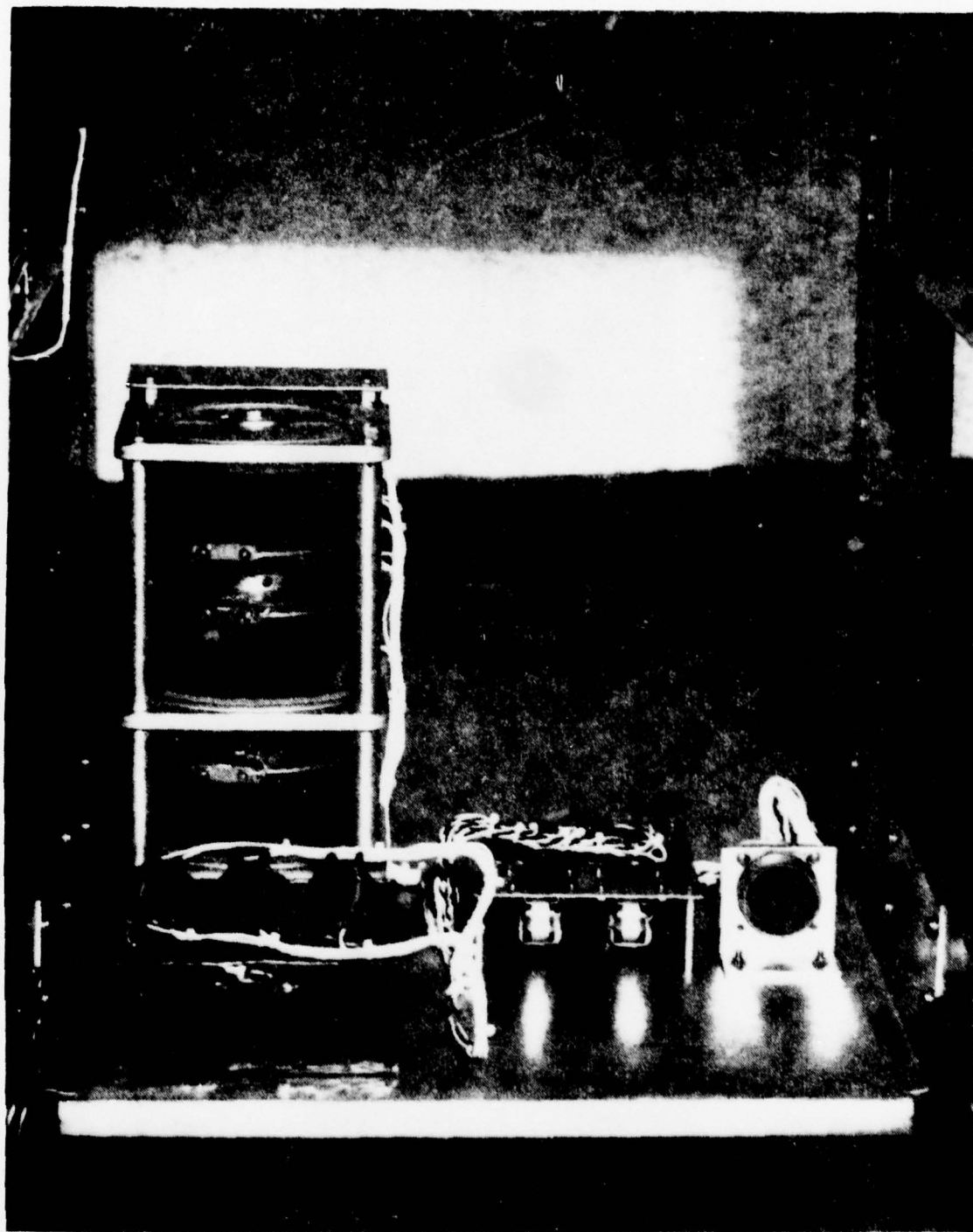


Figure 1-10. TRANSFORMER ASSEMBLY A1A9

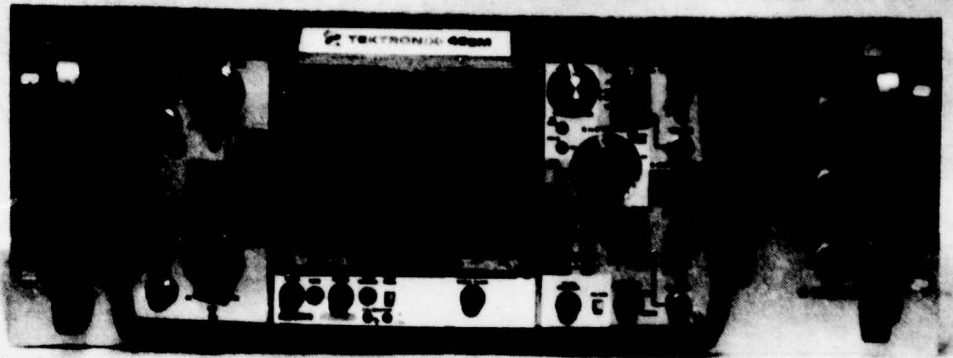


Figure 1-11. OSCILLOSCOPE PANEL A2A3

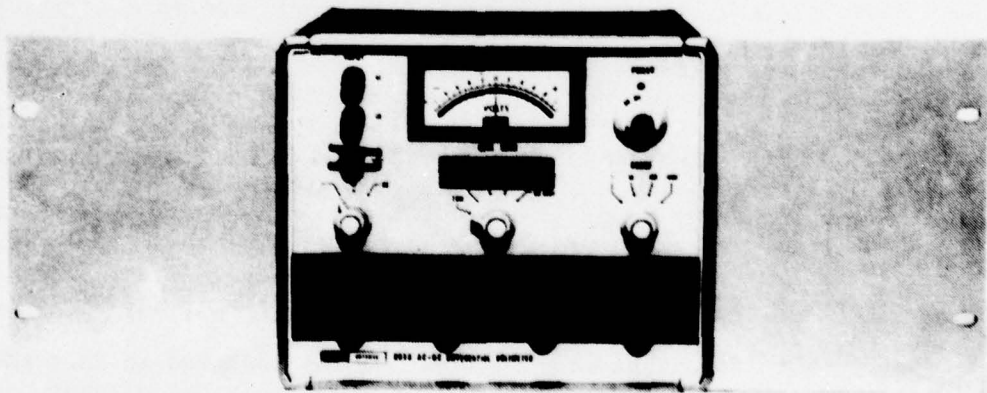


Figure 1-12. DIFFERENTIAL VOLTMETER PANEL A2A1

#### 1.3.2.3 Patch Panel Assembly A2A2

Patch panel assembly A2A2 (see Figure 1-13) contains test points to which the scope and DVM can be connected for measuring the output of the UUT. Cables connecting these points to the UUT are shielded and not load bearing, permitting precise measurements of voltages.

#### 1.3.2.4 Control Panel Assembly A2A4

Control panel A2A4 (see Figure 1-14) contains push-button switches that control all DTS operations; indicator lamps that are integral with the switches display the DTS operating mode. The ON/OFF switch serves as the main power switch: when the switch is in the OFF position, only 28 volts dc is available within the DTS in addition to the voltages at the relay assembly and the utility receptacles mounted in the test bench; when the switch is in the ON position, voltages are supplied to operate the internal power supplies and cooling fans. In this condition, no voltages except 28 volts dc and the voltage at the utility receptacles are available at the test bench or within the A2 equipment rack. When the standby (STBY) switch is depressed, ac voltages are applied to warm up equipment contained in equipment rack A2 but no voltages are applied to the UUT. To operate the UUT, one of the three TEST buttons must be depressed, placing the DTS in one of three available test modes. In the event of an overload, the DTS will automatically cycle to the overload (OVLD) mode of operation and announce this condition by a red illumination of the OVLD switch. In this condition, no voltage is applied to the UUT, and the DTS operation may be restored to STBY by depressing the OVLD switch.

#### 1.3.3 Test Bench A3

Test Bench A3 (see Figure 1-1) consists of an air-cooled cold plate, control panel/junction box, storage drawers, and indicator lamps related to the UUT. Dogging assemblies are provided for attaching the UUT and sub-assemblies (when removed from the main chassis) to the cold plate. The accessory cables and jig assemblies also can be attached to the cold plate. Controls mounted on the test bench are essentially related to testing of the UUT. The cold plate contains safety interlock switches that permit DTS operation only when safety hoods, which shield the operator from exposure to hazardous voltage, are properly installed.

#### 1.3.4 Accessory Jigs, Fixtures, and Test Cables

Accessory test jigs, fixtures, and test cables required to test the power supplies are illustrated in Figure 1-15. Applications of these devices are described in Supplement A-TP100 and Supplement B-TP200 of the DTF.

#### 1.4 Ancillary Equipment

A FET-type multimeter, such as Hewlett-Packard (HP) model 427A, is required to perform the power supply testing. This is not furnished with the DTF. Whatever such device is used, it must include an ohmmeter portion

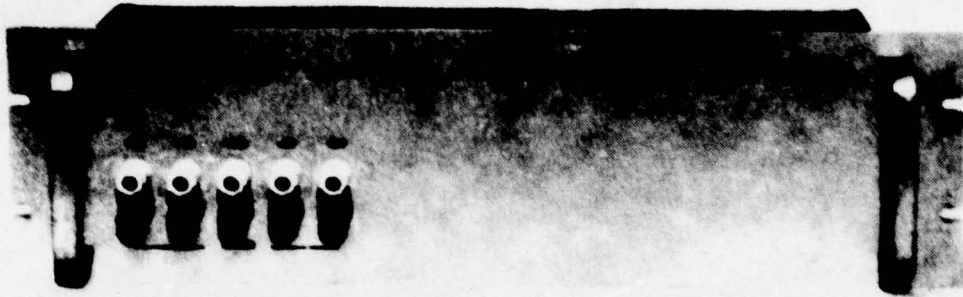


Figure 1-13. PATCH PANEL A2A2

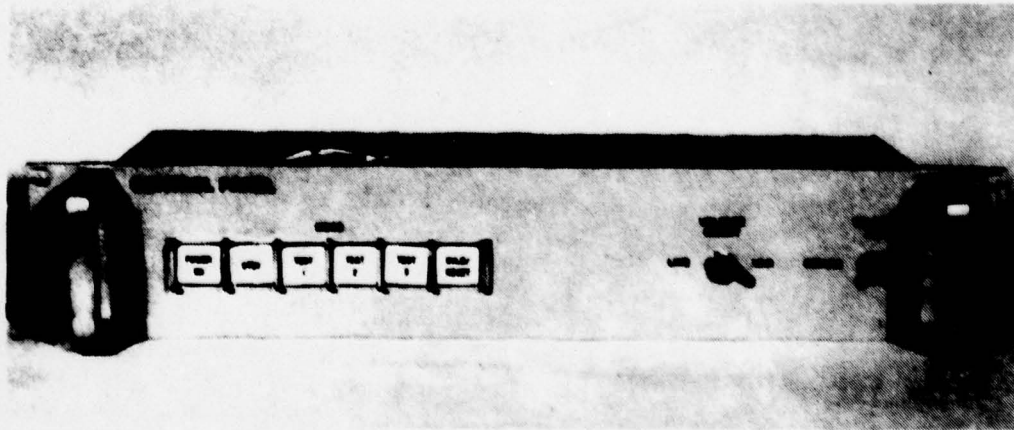


Figure 1-14. CONTROL PANEL A2A1

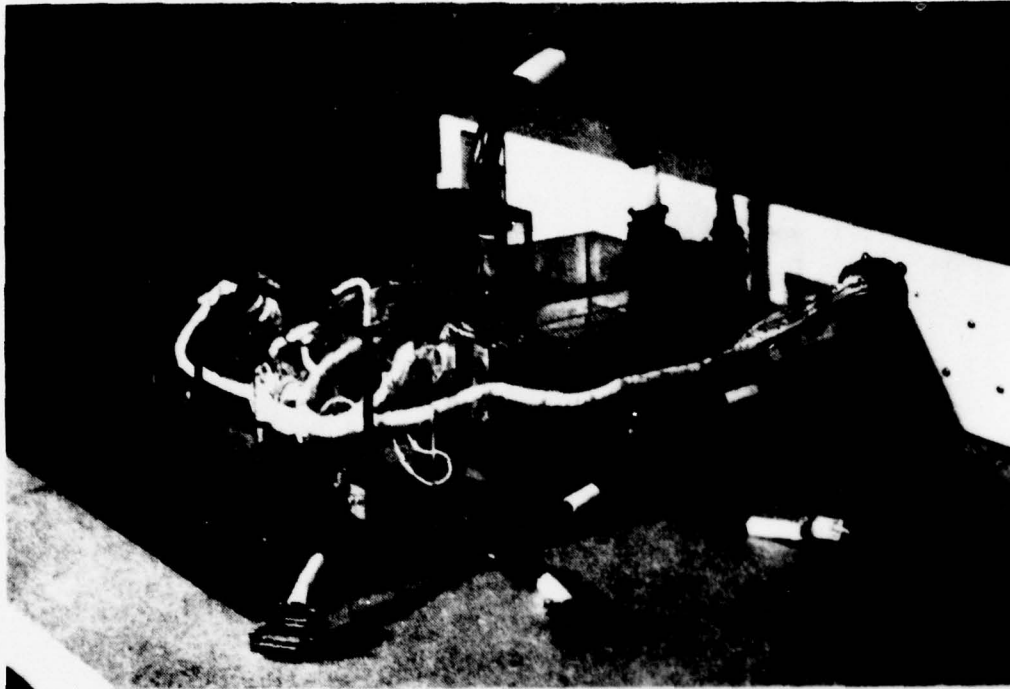


Figure 1-15. JIGS, FIXTURES, AND TEST CABLES

that has a source voltage less than 200 millivolts on the low range scales or test results will be invalid. In this document, use of a HP-427A is assumed.

### 1.5 Safety Information

The DTS incorporates many safety features that protect the operator from exposure to voltages that could result in injury or death. It is important that the operator be familiar with these features and their limitations.

When the DTS is operated in the OFF mode, high voltage excitation is limited to the input junction box (mating internal wiring with the 115/208-volt, 400-Hz, 3-phase external lines), the relay assembly, and the accessory utility receptacles. The relay assembly and input junction boxes are covered to prevent exposure to the operator. Access panels and equipment doors are electrically interlocked to safeguard personnel from exposure to high voltage. The safest means of performing maintenance on the DTS is to disconnect all external power cables located on the left side near the rear of the equipment rack assembly A1.

CAUTION

High Voltage. 115/208 volts ac is present within the DTS equipment cabinets. Exposure to personnel could result in injury or death.

Transparent hoods covering the UUT are provided to protect the operator from exposure to the 115/208 volts. A safety interlock that prevents application of high voltage to the UUT if the hoods are removed is incorporated into the logic circuits. A safety override switch located on the test bench panel can be used to defeat this function, since some equipment measurements may require removal of the protective hoods. When this safety override is used, a large red indicator located on the test panel portion of the bench is illuminated.

CAUTION

High voltage. 115/208 volts ac and 200 volts dc are present on the unit under test. Exposure to these voltages may result in injury or death. It is recommended that the safety circuit override be used with extreme caution and only in the presence of an observer ready to switch the DTS to OFF and perform first aid in case of an emergency.

2.0 TEST PHILOSOPHY

The DTF is designed to aid in the repair and to verify the operation of the AN/ALQ-119 low voltage power supply, part numbers 624R629G01 and 634R149G01 (interchangeable). Section 2.1 outlines the features of the power supply; Sections 2.2 and 2.3 describe the approach used in test procedures TP100 (Supplement A of the DTF) and TP200 (Supplement B of the DTF); and Section 2.4 describes the DTS Operational Modes.

2.1 AN/ALQ-119 Low Voltage Power Supply

The primary power source for the AN/ALQ-119 low voltage power supply\* is 115 volts (per phase) 400 Hz, 3-phase 4 wire. From this source the following voltages are developed:

- 28 volts unregulated\*\* (output only)
  - 12 volts regulated
  - -12 volts regulated
  - 20 volts unregulated
  - -20 volts unregulated
- } internal use and output

\*Refer to Figures 1 through 19 of TP400.

\*\*Regulated in P/N 634R149G01.

- 5 volts regulated (for logic) internal use only
- 5 volts regulated

The  $\pm 12$  volt portion of the power supply, assembly A4, consists of individual positive and negative series regulator circuits. A 3-phase voltage from transformer assembly T1 is rectified in assembly A4 to drive the positive regulating transistor; the -20 volts developed in the T1 assembly drives the negative regulating transistor. The control amplifier in the positive regulator circuit uses the +20 volts from transformer assembly T1; the control amplifier in the negative regulator uses the -20 volts from the same source. The  $\pm 12$ -volt output, therefore, is dependent on the proper operation of the  $\pm 20$ -volt unregulated supplies.

The 5-volt portion of the supply consists of a 50 kHz logic control circuit, various protection circuits, and an inverter circuit. Inverter assembly A3 uses the 3-phase primary power directly to produce the 5-volt output. Regulation is accomplished by using a constant pulse-width 50 kHz, variable pulse-width control circuit. The 5-volt output is dependent on proper performance of most other portions of the supply, as follows:

- $\pm 20$  volts unregulated
- $\pm 12$  volts regulated
- 5 volts regulated (for logic)
- Control circuits
- Protection circuits

## 2.2 DTS Monitoring Capabilities

The monitoring elements of the DTS are its input line monitor panel, load panel, oscilloscope (scope), differential voltmeter (DVM), and patch panel. All precision measurements are made with the DVM. Principal output voltages are measured at terminals located on the patch panel. The scope is used to check power supply ripple and to verify various waveforms developed in the power supply.

The input line monitor panel has a voltmeter for measuring the input voltage. A switch permits the monitoring of the voltage of each of the three phases separately. Voltmeter connections are made on the input side of the 400-Hz control relay to permit continuous monitoring of phase voltage. A true rms line current meter and an associated phase selector switch are also on the panel. Line current monitoring is useful in the identification of transformer and polyphase rectifier problems and as a means of setting internal current limiting circuits. Neutral current is monitored by a true rms current meter mounted on the panel. This provides a simple means of checking the operation of the various polyphase rectifiers contained in the power supply, since an unbalanced load current results in increased neutral current.

The load panel (see Figure 1-6) contains voltmeters for monitoring the output voltages and ammeters for monitoring load currents. Although internally

used supplies are not metered, sufficient information is available to identify problems because of the interdependence associated with the  $\pm 12$ -volt and 5-volt circuits. For example, failure of the internal 20-volt supply would cause simultaneous loss of the 12-volt and 5-volt outputs.

### 2.3 Test Procedures

Test procedures for the AN/ALQ-119 low voltage power supply are presented in Supplements A and B of the DTF; the former pertains to P/N 624R629G01, the latter to P/N 634R149G01. Each supplement contains the following sections:

- General
- Preliminary Test
- Verification Test
- Diagnostic

Once the operator becomes familiar with information contained in the general section, preliminary testing and verification testing should not require reference to the general information. The preliminary test procedure is used to identify units exhibiting symptoms of catastrophic failure. Upon identification of a problem, the operator performs specific diagnostic procedures that lead to identification of the defective parts. Once the repair is made, the operator returns to the preliminary test. If the UUT now meets the preliminary test requirements, the operator performs the verification test to identify any out-of-tolerance conditions in the UUT. If a problem is identified, the operator performs specific diagnostic tests that identify defective parts. When repair has been made, the operator returns to the verification test. If all requirements are met, the UUT is accepted as operational. Diagnostic testing is never performed independently: entrance into the diagnostic procedure is always through instructions provided in the preliminary or verification testing.

### 2.4 DTS Operational Modes

The DTS uses three operational modes, each of which optimizes operation for specific test requirements. Test Mode 1, which is used basically for preliminary testing, permits loading of the 5-volt regulator of the UUT to 10 amperes. Supply line current in Test Mode 1 is limited to approximately 1 ampere. The purpose of this mode is to identify UUTs that exhibit catastrophic failure symptoms.

Test Mode 2 is related to verification testing and uses full-range load capabilities. Supply line current during Mode 2 operation is limited to approximately 3 amperes. Some functions of the diagnostic testing, i.e.,  $\pm 20$  volt or  $\pm 12$  volt portions of the UUT, use Test Mode 2 to facilitate use of additional load-banks. (All load-bank elements are used in Test Mode 2.)

Test Mode 3 is used for testing the UUT with the inverter portion outside the power supply chassis or with the  $\pm 12$  volt regulator portion replaced

with internal DTS supplies. Additional protection circuits are used during Test Mode 3 operation to prevent damage to inverter parts in the event that repair action is incomplete. Line current for Mode 3 operation is limited to 3 amperes.

### 3.0 THEORY OF OPERATION

#### 3.1 General

DTS control is categorized as follows:

- Operational control
- Load control

An operator controls the major part of DTS operation by depressing switches located on the control panel. Operation of these switches results in distribution of primary power throughout the DTS. Automatic control of system operation is provided by the logic portion of the A1A3 card assembly. Switches relating to maintenance of the power supplies are located on the test bench for operator convenience.

An operator controls the loading of a UUT by means of load switches and controls located on the load panel. Only portions of the load applicable to the selected test mode are enabled. Applicable load portions are indicated by illumination of green enable lamps. Automatic control of load-enabling circuits is provided by the logic portion of the A1A3 card assembly.

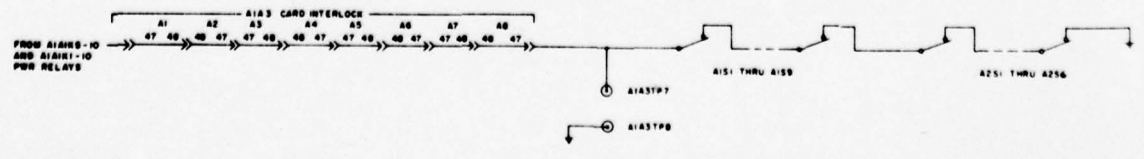
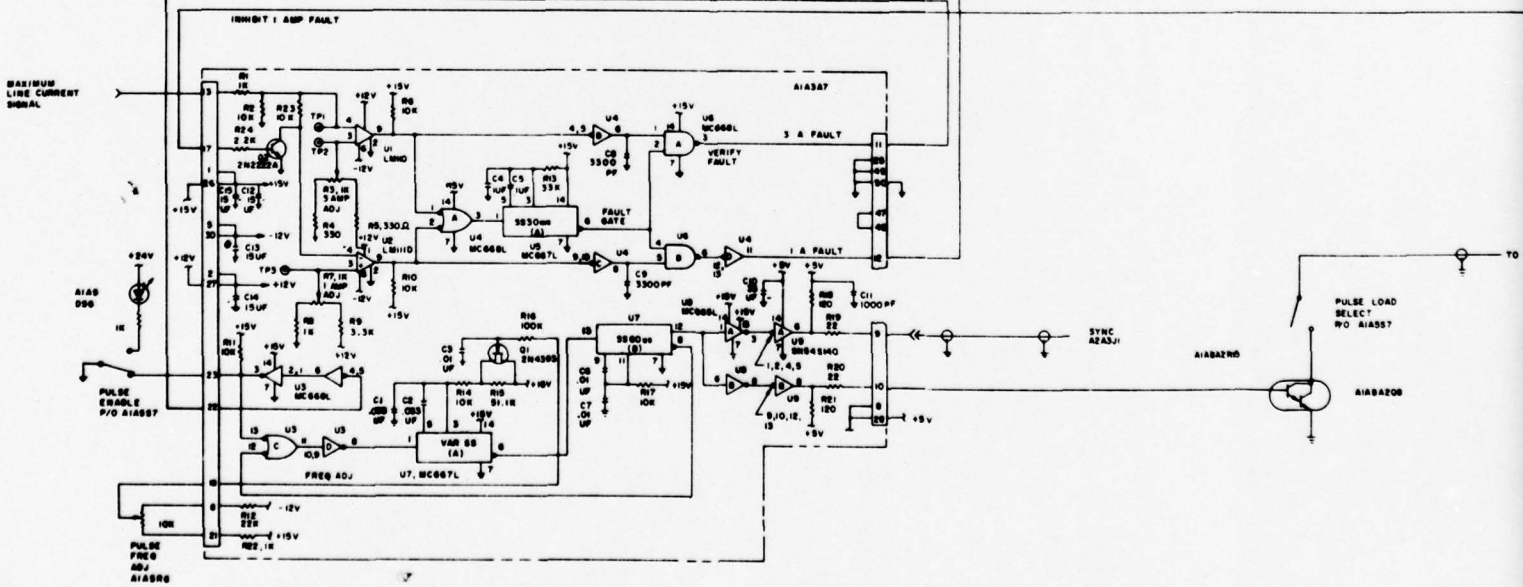
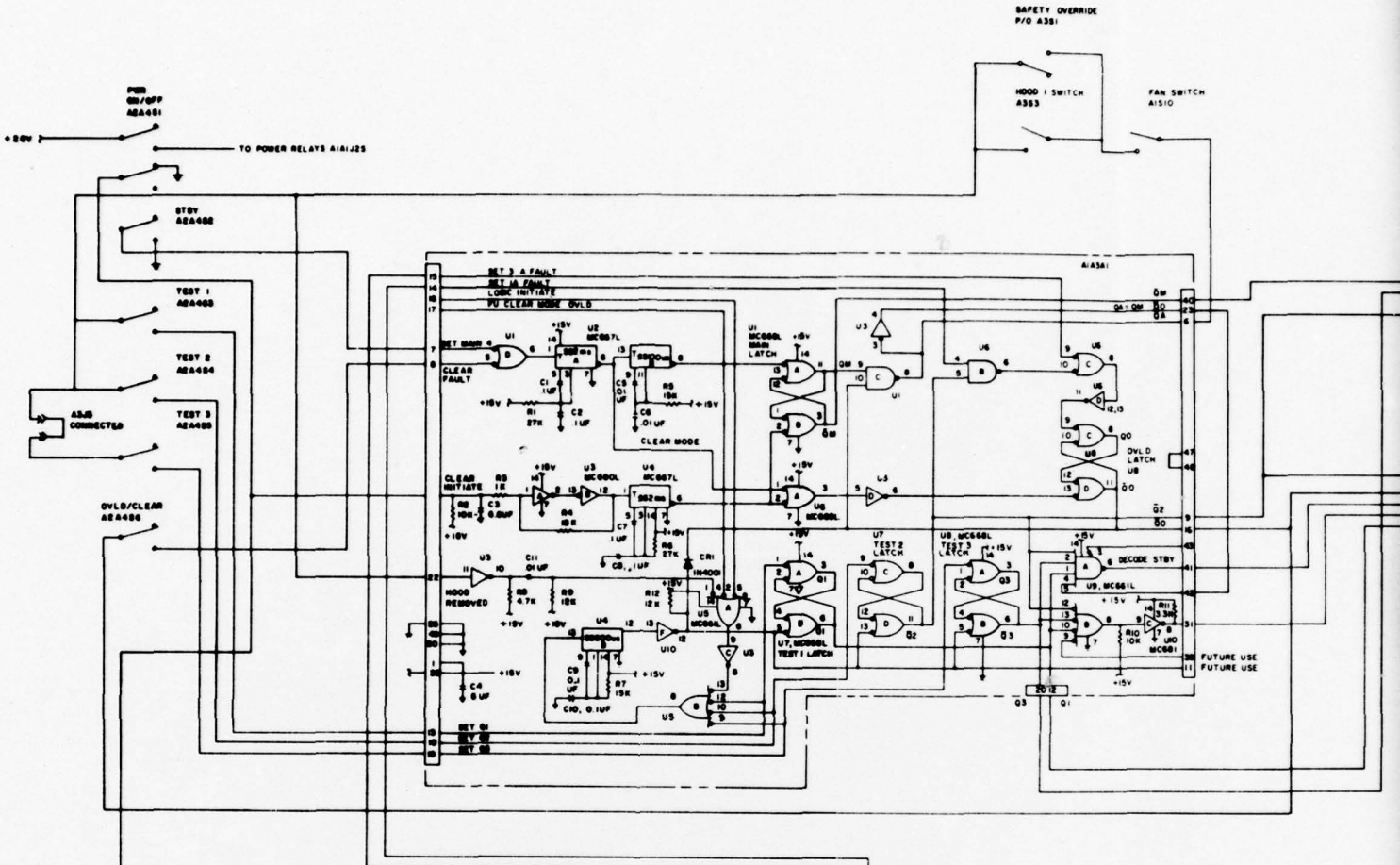
#### 3.2 Logic Control and Power Distribution Circuits

High threshold logic (HTL) integrated circuit (IC) devices, series MC660, are employed in the DTS. They operate from a 15-volt source with a threshold voltage of 7.5 volts. The maximum low logic level is 1.5 volts and the minimum high level is 12.5 volts, providing a logic swing of approximately 11 volts and a resultant high degree of noise margin. The typical gate output circuits are not compatible with transistor input circuits; therefore, interface is provided by a MC665L device, which contains three level-translator circuits (each capable of driving a transistor base current of 2.5 milliamperes). The maximum low-level output of the translator is 0.5 volt; the minimum high-level output is 2.5 volts. An additional 5-volt supply is used for the translator output circuit.

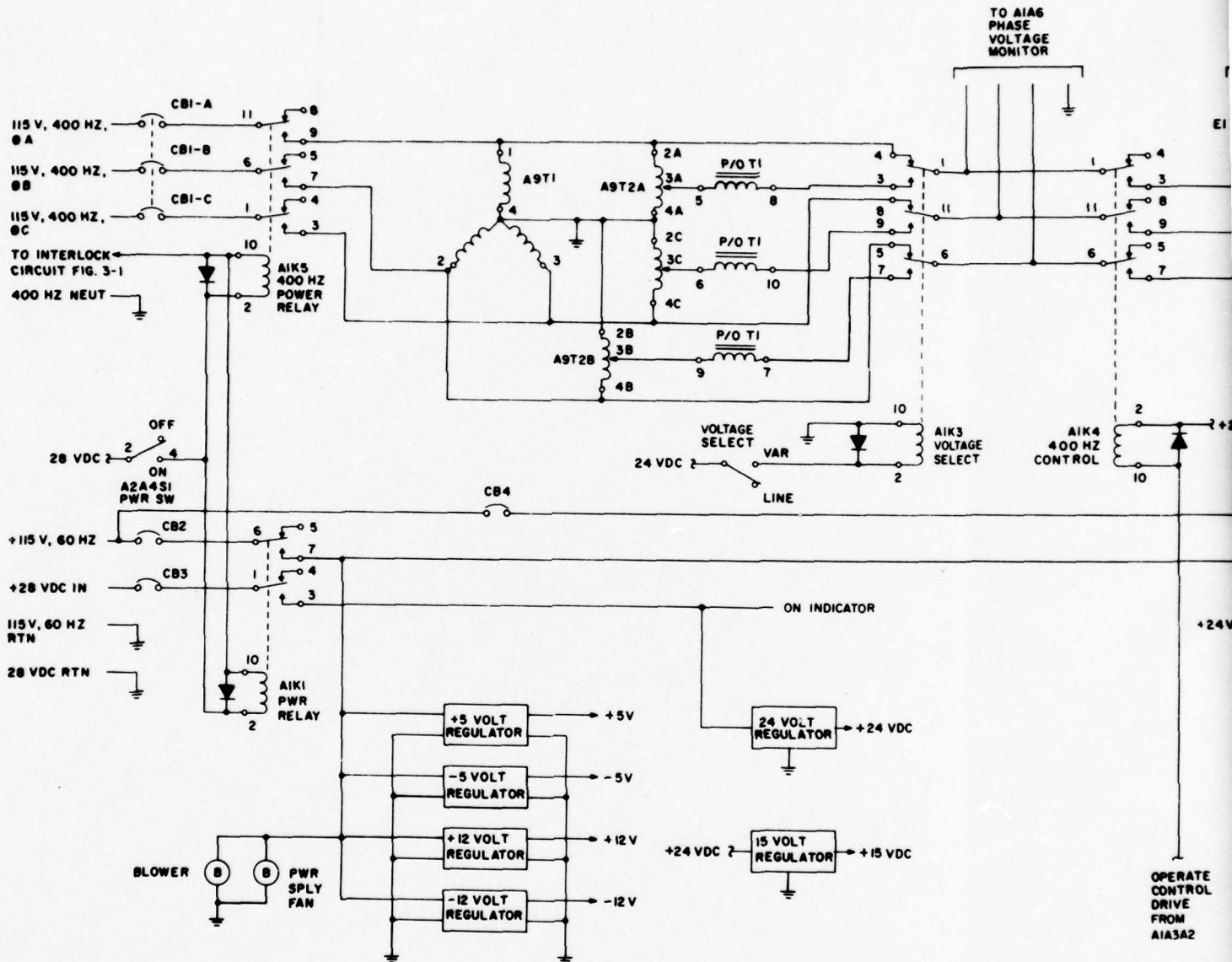
Figure 3-1 presents a simplified diagram of the logic control circuits. Figure 3-2 presents a simplified power distribution diagram. These figures are discussed in Subsections 3.2.1 through 3.2.11.

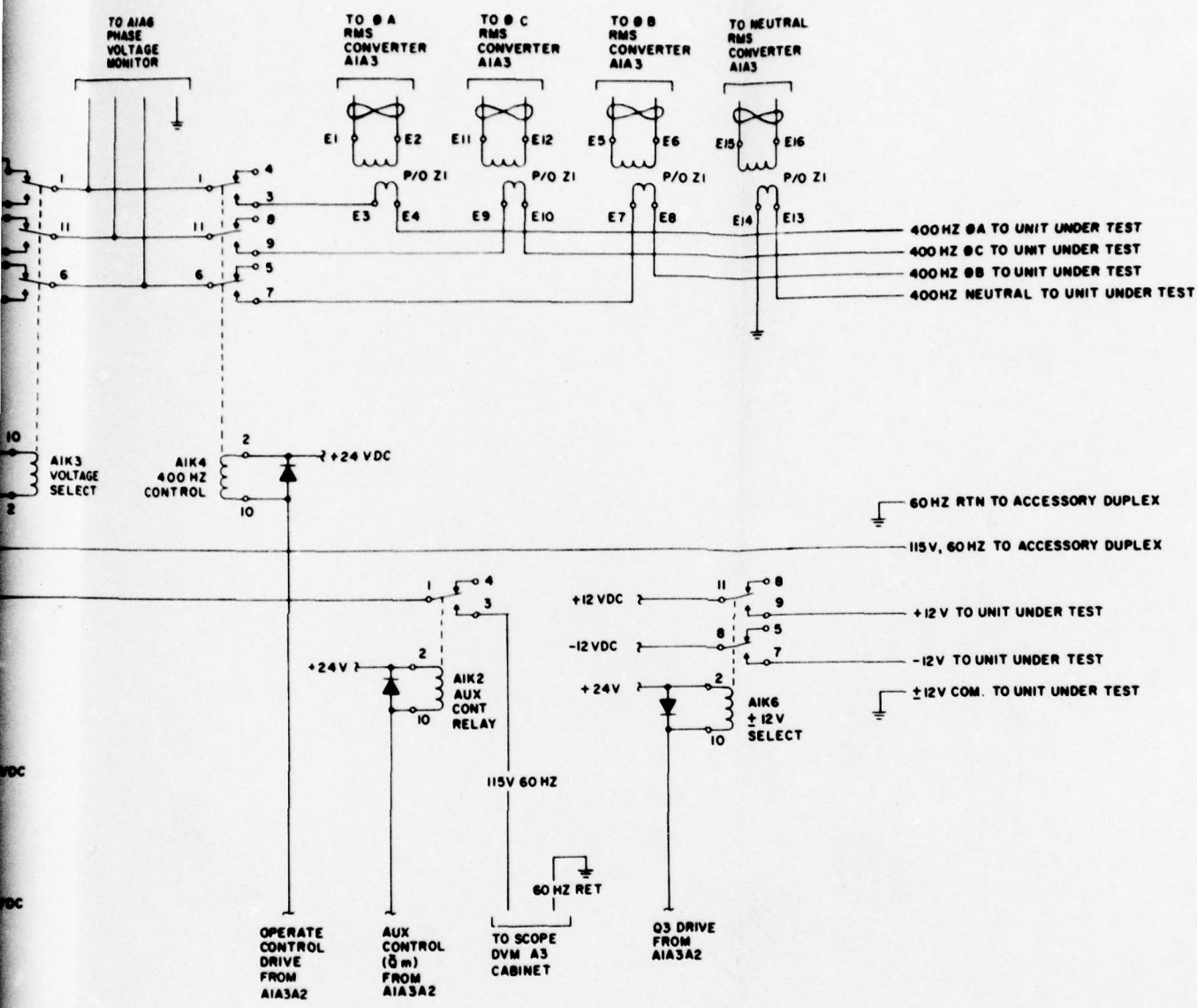
##### 3.2.1 ON/OFF Control

Operation of the DTS is initiated by depressing the power ON/OFF switch-indicator shown in Figure 3-1. The power switch remains closed and holds









2

Figure 3-2. SCHEMATIC OF THE DTS POWER DISTRIBUTION

the equipment ON as indicated by illumination of the switch-indicator. On the second depression, the power switch opens, thereby terminating equipment operation. When the switch is depressed ON, 28 volts dc is applied to the relay coils of AlK1 and AlK5 (see Figure 3-2). The relay coils are returned to ground through the cabinet interlock circuit (see the lower portion of Figure 3-1). If all cabinet interlock switches are closed and card assemblies AlA3 are in place, power relays AlK1 and AlK5 will close. This action results in application of 115 volts, 60 Hz to the  $\pm 5$ -volt and  $\pm 12$ -volt internal power supplies (AlA2), power supply fan, and equipment cooling fan (AlA4). The 28-volt dc source is also applied to the 24-volt and 15-volt regulator circuits. As the blower speed increases, the fan switch AlS10 closes, indicating that cooling air is flowing through the cold plate and solid-state load assemblies.

### 3.2.2 Logic Initiation

The ensuing discussions pertain to the logic card AlA3A1 (see Figure 3-1). Placing the equipment in the ON condition (see Subsection 3.2.1) causes application of internal power supply voltages to the logic circuit and other DTS control circuits. Capacitor AlC3 initially charges from 0 to 15 volts, triggering the Schmitt trigger U3A/B and the 2-millisecond single-shot (SS) U4. During this 2-millisecond period, low-level logic signals are applied to the main latch U1A/B, Test 1 latch U7A/B, Test 2 latch U7 C/D, Test 3 latch U8A/B, and the overload (OVL D) latch U8C/D, clearing the latches and initiating logic control.

### 3.2.3 Standby Operation

The equipment is placed into standby operation by momentarily depressing the STBY switch, which applies a momentary low-logic level to AlA3A1 U1D. The output of U1 toggles the 2-millisecond SS U2A. During this period, low-level logic signals are applied to clear all latches except the main latch U1A/B. Upon termination of the 2-millisecond low-level pulse U2A, the 100-microsecond SS U2B is toggled. The low-level logic signal from U2B sets the main latch. Standby operation is defined as the condition in which only the main latch is set. "NAND" gate U9A decodes this condition. DTS operation may be returned to STBY from any operating mode by momentarily depressing the STBY switch.\*

### 3.2.4 Test Mode 1 Operation

The DTS may be placed into Test Mode 1 by momentarily depressing Test 1 switch, with the following restrictions:

- The OVL D lamp is not illuminated
- The equipment has been cycled to Standby Operation

---

\*The DTS may remain in the OVL D condition if the AlA3S1 CAL SEL switch is not in the OPR position.

- The main cooling fan is operating
- Protective hood #1 is positioned on the cold plate\*

Test Mode 1 operation is explained as follows:

- "NAND" gate U1C produces a low-level output signal  $\bar{Q}A$  when the main latch is set and the OVLD latch is not set.
- $\bar{Q}A$  is applied to the common terminals of the Test 1 switch and the Test 2 switch through the series contacts of the fan switch and the hood #1 switch.
- Momentary depression of the Test 1 switch conditionally provides a low-level logic signal to A1A3A1P13.
- A momentary low-level signal toggles the 800-microsecond SS U4B.
- During this period Test latches 1, 2, and 3 are cleared.
- The single Test 1 latch is subsequently set, since the Test 1 switch will still be depressed subsequent to the 800-microsecond clear period.

This clear-then-set action allows the DTS to cycle between any selected operate mode or standby. If the 3-phase, 400-Hz line current exceeds 1 ampere, a high-level logic signal (12.5 volts minimum) will appear at A1A3A1U6 pin 4. For Test 1 and Test 3, the signal at U6 pin 5 is also high. Under these conditions, a 1-ampere fault signal is applied through U6C and U6D setting the OVLD latch U8C/D. When the OVLD latch is set, latches of Test 1 through Test 3 are held in the clear state by the connection of diode CR1. Operation may be returned to standby by depressing the OVLD RESET switch or the STBY switch.

### 3.2.5 Test Mode 2 Operation

Test Mode 2 operation is selected by a momentary depression of the Test 2 switch. Circuit operation is similar to that of Test Mode 1 except that Test 2 latch is set and the low level Q2 signal is applied to A1U6 pin 5. This signal inhibits the 1-ampere fault signal from setting the OVLD gate. If the 3-phase line current exceeds 3 amperes, a low-level fault signal is applied to the input of the OVLD latch through the negative "OR" gate U6C and inverter U6D, setting the latch.

### 3.2.6 Test Mode 3 Operation

Test Mode 3 operation is attained by momentarily depressing the Test 3 switch. Circuit operation is similar to that of Test Mode 1 except that A3P3 must be connected to A3J3 to complete the Q3 set signal and that latch Q3 is set. The 1-ampere fault gate is active as in Test Mode 1 operation.

---

\*Refer to Section 1.5 for safety information.

### 3.2.7 Decode Operate

Negative "OR" gate ALA3A1U9B decodes the operate condition. Power is applied to the UUT when the Test 1, Test 2, or Test 3 latches are set. Under any of these conditions, a low-logic level is developed at ALA3A1P1-31. This signal controls application of power to the test bench.

### 3.2.8 Current Drives

Card ALA3A2 contains the logic current drive circuits. A low-level logic signal at the input circuits provides base drive to one of the eight Darlington transistors, turning it on. Control relays and indicator lamp circuits are returned to ground through the collector-emitter circuits of the driver transistors. Transistor Q1 and resistor R1 constitute a driver for the logic-enable circuits ALA3A3, ALA3A4, and ALA3A5. Inverter U3B drives transistor ALA3A7Q1 into conduction during Test Mode 2, inhibiting action of the 1.0 ampere fault signal.

### 3.2.9 OVL D Monitor/Pulse Generator

Card ALA3A7, illustrated in Figure 3-1, consists of 1-ampere and 3-ampere overload detectors and a pulse generator circuit. Operation of the overload detector is explained as follows:

- A dc voltage proportional to the highest 3-phase, 400-Hz line current is applied to ALA3A7P1 pin 13.
- Transistor Q2 on the card is turned on during Test Mode 2 operation, inhibiting application of the current signal to the input of U2 on the card (inhibits the 1-ampere fault).
- A voltage proportional to a 3-ampere signal (developed in the voltage divider R3, R4, and R5) is applied to pin 3 of the U1 voltage comparator.
- When the current signal applied to pin 4 of the comparator exceeds the 3-ampere level, the output U1 pin 9 switches from the normal high level to the low logic level.
- During this overload condition, a high logic signal is applied to the 30-millisecond SS U5 through "OR" gate U4A, to "NAND" gate U6A pin 1.
- A high logic signal, delayed a few microseconds, is applied to the "NAND" gate U6A.
- Output of the "NAND" gate U6A is inhibited by the low-level 30-millisecond fault signal developed at U5A.
- If the excess 3-ampere line current signal is still applied to the U6A "NAND" gate subsequent to the 30-millisecond fault gate, a low-level logic fault signal is developed at U6 pin 3.
- The 3-ampere fault signal sets the OVL D latch (U8C/D) on card ALA3A1, terminating test operation and illuminating the OVL D lamp.

- OVLD detection is accomplished in a similar manner for Test Mode 1 and Test Mode 3 operation except that Q1 is off, U2 is the active voltage comparator, and U6B is the fault gate. A 1-ampere high-level signal developed at the output of the U4D inverter sets the OVLD latch for Test Mode 1 and Test Mode 3 operation.

Operation of the pulse generator portion of A1A3A7 is explained as follows:

- SS U7A, SS U7B, and U3C/D form a feedback pulse generator.
- Pulse generator select switch A1A5S7 in the OFF position applies a low (ground) signal to U3 pin 13, inhibiting operation of the generator circuit.
- When the pulse select switch is placed in the ON position, a high logic signal applied to U7 pin 1 through U3C/D toggles the SS U7A.
- Termination of the low logic U7A pulse toggles the 60-microsecond SS U7B.
- The output of U7B pin 8 holds U7 pin 1 low through the action of the gate U3C/D for the 60-microsecond period.
- Termination of the 60-microsecond low period results in re-toggling of the U7A SS, generating continuous feedback oscillation.
- The U7 pin 12 pulse output is applied to the level translators U8A and U8B, which develop transistor-transistor-logic (TTL) signal outputs for driving the 50-ohm TTL line drivers U9A and U9B.
- Identical 60-microsecond positive 5-volt pulses are generated at P1 pin 9 and P1 pin 10.
- The drive pulse at P1 pin 10 is applied to the Darlington transistor A1A8A2Q8, which develops a 5-ampere pulse load for the 5-volt supply portion of the UUT.
- The FET Q1 together with the frequency adjust potentiometer acts as a variable resistance across R15. The circuit of U7A is a voltage-controlled pulse width generator controlling the oscillator frequency.
- The logic-initiated signal applied to P1 pin 22 ensures that oscillation will start in the event that the DTS is turned on with the pulse generator select switch in the ON position.

### 3.2.10 Test Table Controls

Test table controls (see Figure 3-1) consist of an inverter OFF/ON switch and a safety override switch. Safety override allows operation of the UUT with the protective hood #1 removed.\* A large red lamp is illuminated when the safety override switch is ON, indicating hazardous operating conditions. The inverter OFF/ON switch and indicator lamps A3DS3 through A3DS5 apply only to Test Mode 3 operation when the inverter assembly is

---

\*Refer to Section 1.5 for safety information.

extended outside the UUT. Three-phase power to the inverter is patched through PS1A1J3, contacts of relay A31K1, and the 75-ohm resistors A3R1 through A3R3. During extended operation, hood #2 installed over the inverter protects the operator from exposure to hazardous voltage potentials. When the inverter switch is placed in the OFF condition, hood #2 may be removed and the operator may conduct measurements on the inverter assembly without compromising safety procedures (hazardous voltages are inhibited from the inverter). Amber lamp A3DS2 is illuminated when the inverter switch is in the OFF condition, indicating that output of the 5-volt portion is inhibited.

### 3.2.11 Power Distribution Circuits

Distribution of power within the DTS is illustrated in Figure 3-2. Operation of the circuit is explained as follows:

- First depression of the power ON/OFF switch applies 28 volts dc to the coils of the power relays A1K1 and A1K5. The coils are returned to ground via the interlock circuit illustrated in the lower portion of Figure 3-1. Under normal conditions, relays A1K1 and A1K5 are energized upon turn-on. Contacts of the A1K1 relay apply 115-volts 60-Hz power to the  $\pm 5$ -volt and  $\pm 12$ -volt power supplies, power supply fan, and cooling fan. Contacts of A1K1 also apply 28 volts dc to the 24-volt and 15-volt regulator portions of the supply. Three-phase 400-Hz power is applied to the A9T1 transformer assembly through the closed contacts of A1K5.
- Momentary depression of the standby switch sets Qm, providing a return path for the coil of the auxiliary control relay A1K2. Contacts of relay A1K2 supply 115-volt 60-Hz power to the oscilloscope and the differential voltmeter.
- When Test Mode 1, 2, or 3 is selected, a return path is provided to the coil of the operate relay A1K4 by the operate control drive. Contact of relay A1K4 applies 3-phase 400-Hz power to the UUT.
- Contacts of the VOLTAGE SELECT relay A1K3 connect the 3-phase 400-Hz lines to the motor driven variable transformer assembly when the VOLTAGE SELECT switch is placed in the VAR position or to the 3-phase line when the voltage select switch is placed in the LINE position.
- Contacts of relay A1K6 connect the  $\pm 12$ -volt internal power supplies to test connectors on the A3 bench when Test Mode 3 is selected.
- The four current transformers in the A1A9 assembly sense 400-Hz line current furnished to the UUT.

### 3.3 Metering Card A1A3A8

Figure 3-3 presents the schematic diagram for the metering card assembly A1A3A8. The assembly consists of an ac-rms to dc converter circuit and a meter amplifier circuit. U1 is an IC rms to dc converter device. Output of the neutral sensing current transformer loaded with 464 ohms is applied across P1 pin 8 and P1 pin 25. This voltage signal is proportional to the ac

current flowing in the neutral line of the UUT. Approximately 20 percent of the voltage applied to P1 pin 8 is dropped across R1. Output at U1 pin 12 is a dc voltage proportional to the true rms value of neutral current. Resistors R8 and R9 establish an output amplifier gain of 5:1; thus an overall circuit gain of unity is achieved in the RMS conversion. Capacitors C1 and C2 establish the cutoff frequency for the converter. Potentiometer R3 provides  $\pm$  balancing of the converter at approximately 7 percent of the full range output. Potentiometer R5 allows for calibration of 7 percent output. Potentiometer R1 provides for  $\pm$  balancing at two-thirds full range output, while R7 provides for calibration at two-thirds output. Dc output of the converter is applied to P1 pin 9 of the card assembly. An internal calibration circuit in the A1A3 drawer assembly is discussed in Section 3.6.

IC U2 and associated circuits constitute the meter amplifier for the 5-volt load current. Pins 18 and 19 of J1 are connected to the potential terminals of a precision shunt (Figure 3-9) rated at 60 amperes. Differential gain of the stage is established at 25 by resistors R10, R11, R12, and R14. Capacitors C3 and C4 establish cutoff frequency for the stage. Resistor R10 is used for zero adjustment.

### 3.4 Rms Converter A1A3A6

The rms to dc converter is illustrated in Figure 3-4. Operation of the individual circuits is identical to the ac rms to dc converter discussed in Section 3.3 except that input voltage to the converters is proportional to the A-, B-, and C-phase 400-Hz lines, respectively. Input and output connections are defined as follows:

<u>Function</u>	<u>Pin Connection</u>
• Line A monitor (input)	P1-11
• Line B monitor (input)	P1-8
• Line C monitor (input)	P1-16
• A output	P1-12
• B output	P1-9
• C output	P1-17
• Maximum line current output	P1-10*

### 3.5 Load Circuits

#### 3.5.1 General

An operator controls power supply loading by means of load bank switches and adjustment controls located on the A1A5 load panel. Logic circuits contained in the A1A3 assembly automatically enable specific portions of the load bank applicable to the test mode selected by the operator. Setting of

---

\*Input to current fault detector A1A3A7.

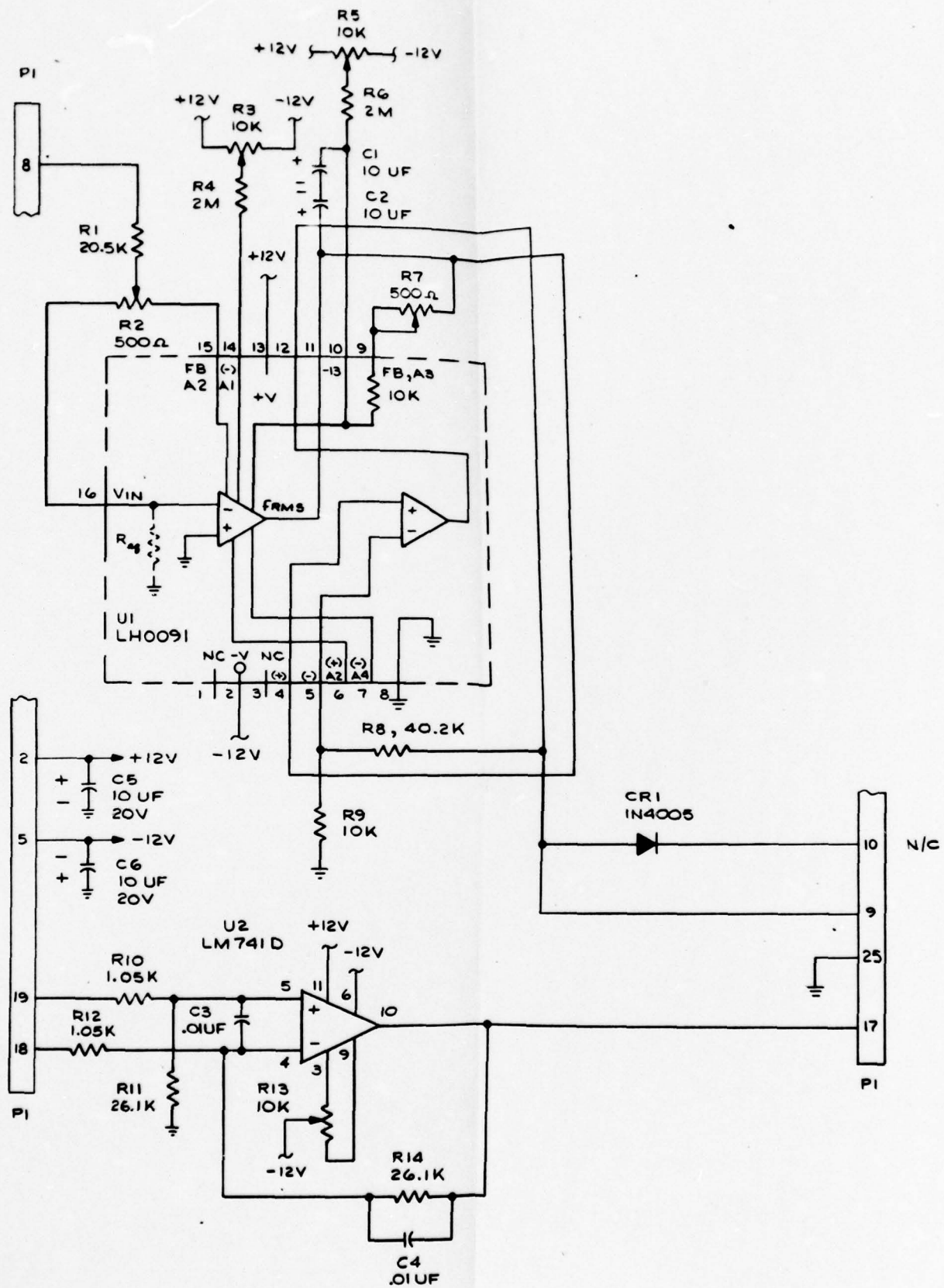


Figure 3-3. SCHEMATIC OF METERING CARD ASSEMBLY A1A3A8



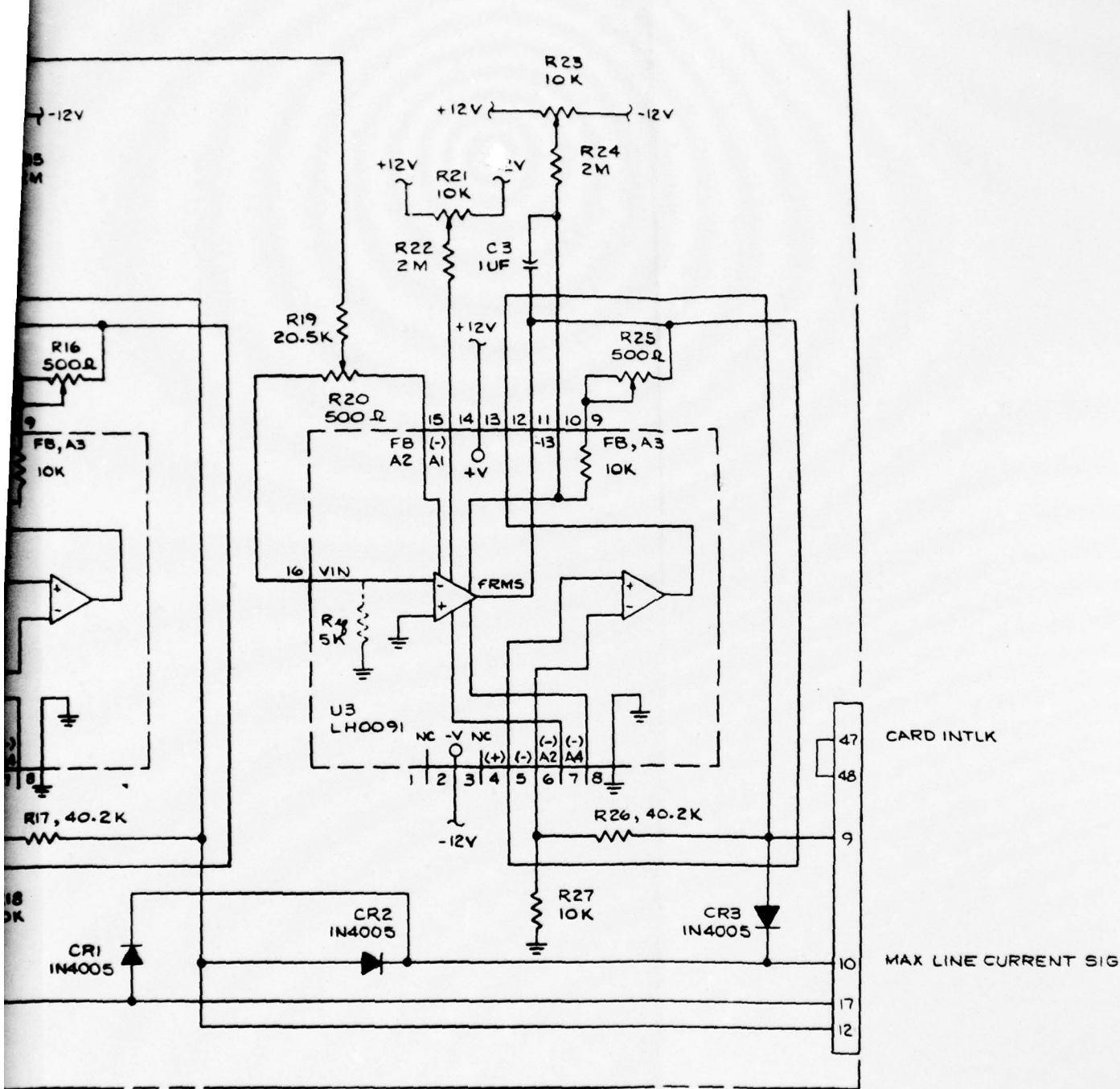


Figure 3-4. SCHEMATIC OF THE RMS CONVERTER A1A3A6

2

controls on the load panel adjusts the amount of base drive applied to each Darlington power transistor located in the load assembly A1A8.

### 3.5.2 Positive Load Circuit

Operation of the positive position of the load circuit is illustrated in Figure 3-5, a simplified schematic drawing and Table 3-1. A low logic program signal applied to the input of a MC665 translator device located on card A1A3A3/A4 enables a load circuit. This causes a current to flow in the diode portion of an optical coupler device type MCA231. Light energy developed in the light-emitting diode (LED) is coupled to the base circuit of a photo-sensitive transistor, switching it ON. Current flowing through the collector-emitter junction of the photo-sensitive transistor and the base-emitter of the 2N2219A transistor cause the emitter of the 2N2219A to rise to approximately +4.8 volts. This emitter voltage is applied across the load current adjustment circuit and the load enable indicator LED circuit. Illumination of the enable lamp indicates that the load circuit is enabled. The operator places the load bank switch located on the A1A5 assembly to the ON position and adjusts the current flowing in the base-emitter circuit of the Darlington power transistor. The amount of current flowing from the load through the Darlington power transistor is proportional to the setting of the current adjustment control. The fixed series resistor located in the base circuit of the Darlington transistor is preselected to limit the maximum load current in the collector circuit. A calibration potentiometer located in the A1A7 assembly allows for a small adjustment of maximum load current for each load bank. The 0.5-ohm emitter resistor is not used in the 5-volt load circuit.

### 3.5.3 Negative Load Circuit

The negative load circuit is illustrated in Figure 3-6 and Table 3-1. Operation of the circuit is identical to that of the positive circuit except that negative potentials are used in conjunction with complementary transistor types (PNP). Reversing the emitter-collector leads on the transistor portion of the type MCA231 optical-coupler permits the use of identical input circuits. Connection of the LED indicator is also reversed for potential compatibility.

### 3.5.4 Part Association

Table 3-1 associates each load bank function with the program card source, load adjustment control, calibration adjustment designation, load assembly, and specific Darlington load transistor. Maximum design load currents for each bank are also identified in the table.

### 3.6 Card Assembly A1A3 Connection and Calibration Circuit

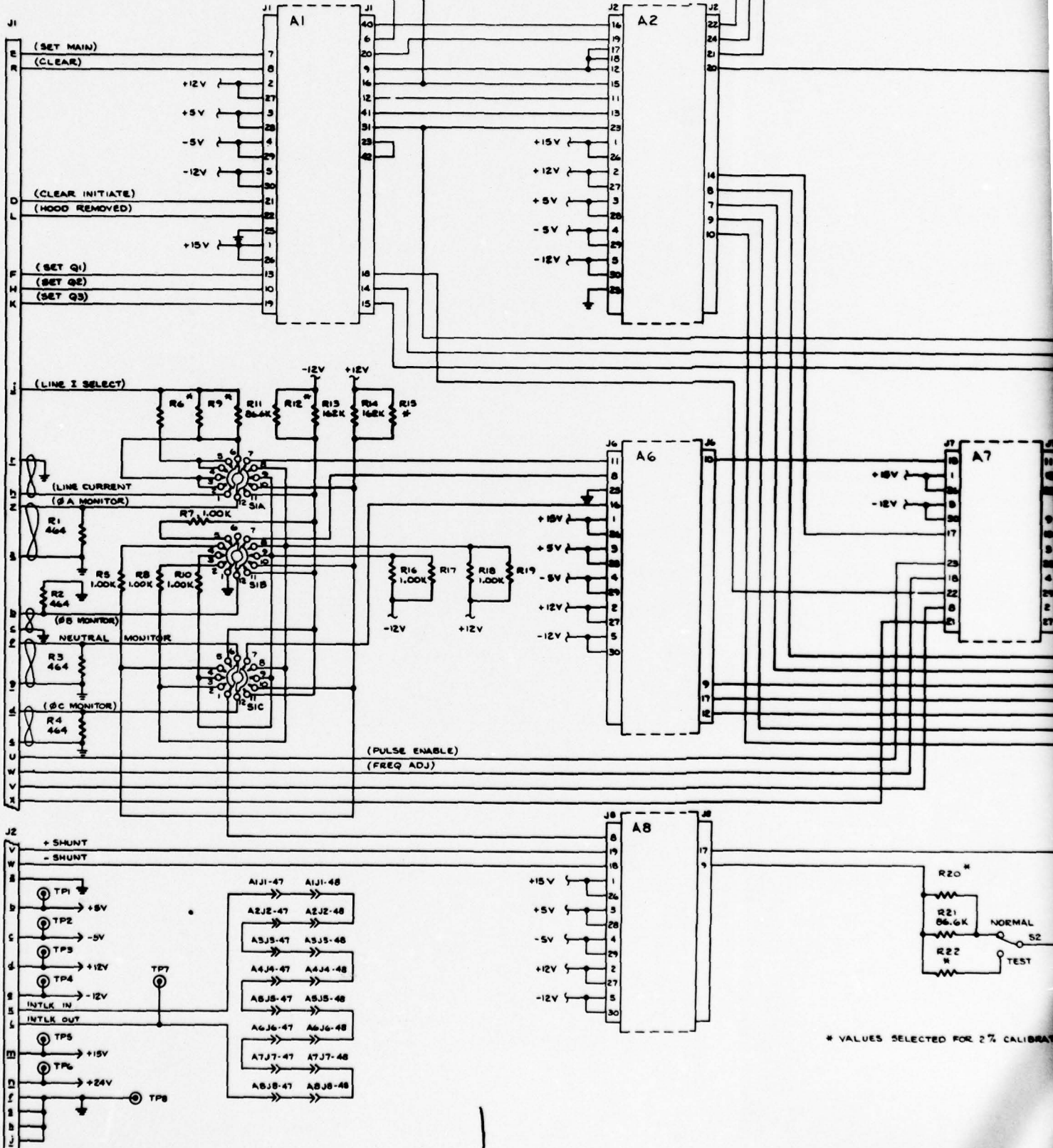
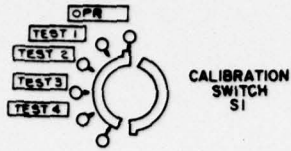
Figure 3-7 presents the schematic drawing for the A1A3 assembly and details the interconnection of the various card assemblies previously discussed. Details of the internal calibration circuit are described below.



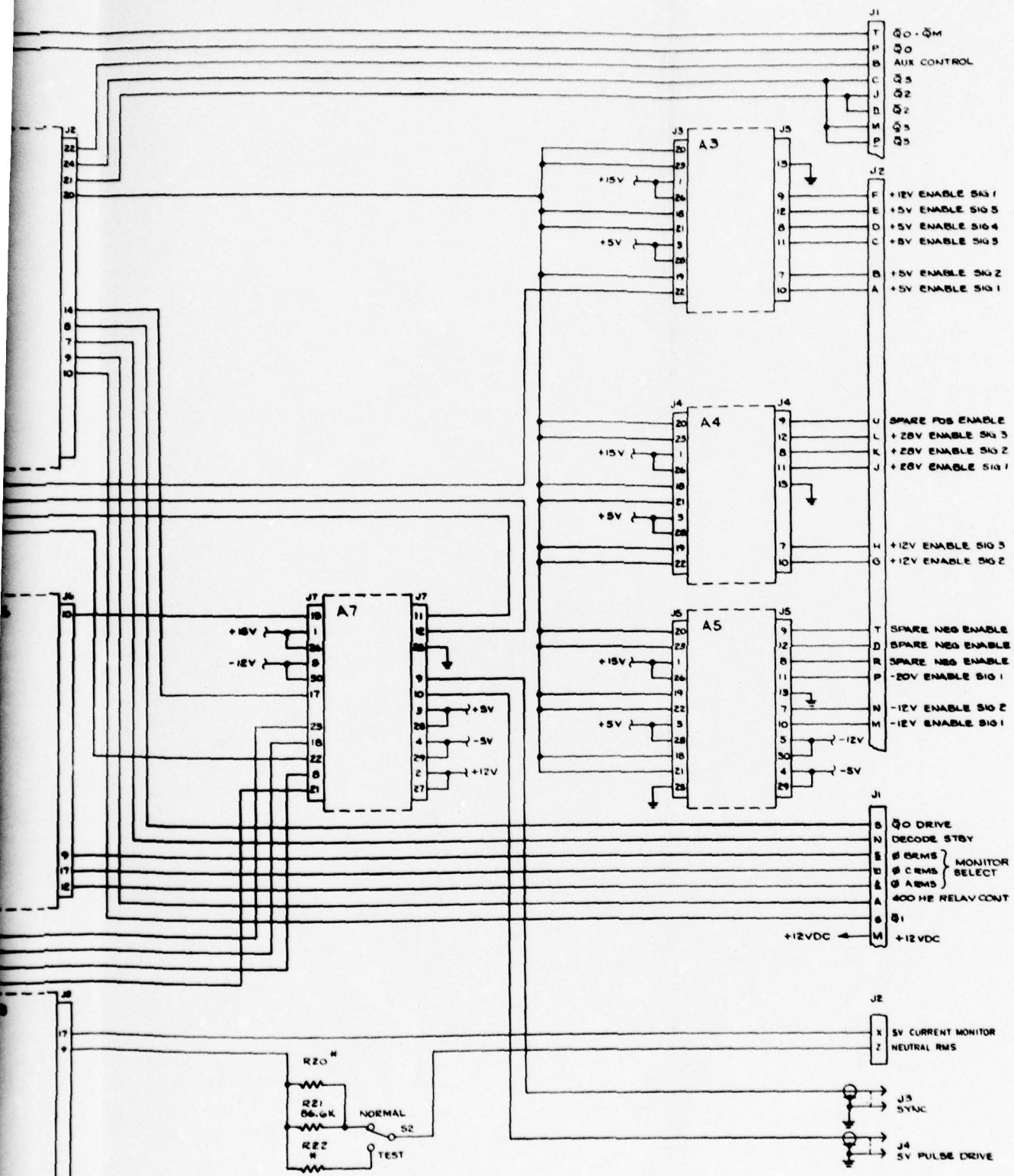


Table 3-1. IDENTIFICATION OF LOAD CIRCUIT ELEMENTS

Load Designation	Bank Number	Program Card	Program Signal Pin	A1A5 Adjustment Designation	Calibration Potentiometer A1A7	Maximum Current Amps	Load Assembly Number	Load Transistor Designation
5-volt load	1	A1A3A3	22	R1	R1	11	A1A8A1	Q1
	2		19	R2	R2	11		Q2
	3		21	R3	R3	11		Q3
	4		18	R4	R4	11		Q4
	5		23	R5	R5	11		Q5
A-load (+12V)	1	A1A3A3	20	R7	R6	5	A1A8A2	Q1
	2	A1A3A4	22	R8	R7	5		Q2
	3	A1A3A4	19	R9	R8	5		Q3
B-load (+28V)	1	A1A3A4	21	R10	R9	2	A1A8A2	Q4
	2		18	R11	R10	2		Q5
	3		23	R12	R11	2		Q6
C-load (-12V)	1	A1A3A5	22	R13	R12	5	A1A8A1	Q6
	2		19	R14	R13	5		Q7
D-load (-20V)	1	A1A3A5	21	R15	R14	3	A1A8A2	Q7



\* VALUES SELECTED FOR 2% CALIBRATION



\* VALUES SELECTED FOR 2% CALIBRATION

2

Figure 3-7. SCHEMATIC OF CARD ASSEMBLY A1A3

The 400-Hz, 3-phase 4-wire current supplied to the UUT is sensed by current transformer assembly A1A6Z1 as shown in Figure 3-2. Secondaries of the four current transformers are connected to the A1A3 assembly as follows:

<u>Function</u>	<u>Pin Connection</u>
• Neutral line monitor	J1-f
• Neutral line return	J1-g
• Line A monitor	J1-Z
• Line A return	J1-a
• Line B monitor	J1-b
• Line B return	J1-c
• Line C monitor	J1-d
• Line C return	J1-e

Secondaries are loaded with 464-ohm resistors R1 through R4. Calibrate switch S1, in the operate position, connects the input circuits to metering cards as follows:

<u>Function</u>	<u>Pin Connection</u>
• Neutral line monitor	J8-8
• Line A monitor	J6-11
• Line B monitor	J6-8
• Line C monitor	J6-16

Converter circuits on these card assemblies develop a dc output voltage proportional to the true rms current flowing in the transformer primary windings. Each rms circuit contains four calibration adjustment potentiometers. Calibration switch S1 provides a built-in means of calibrating the converter circuits. When the calibration switch is placed in test positions 1 through 4, all of the converter input circuits are disconnected from the 464-ohm resistors and parallel-connected to reference voltage sources. Precision application of the calibration requires that the internal  $\pm 12$  volt supplies be adjusted to a  $\pm 1$  percent tolerance prior to circuit calibration. Resistors R13, R14, R17, and R18 are selected at assembly to provide reference voltage tolerance of  $\pm 2$  percent. Reference voltage for the test positions are listed in Table 3-2. Switch S1 removes current from the reference sources during normal operation to maintain long-term stability of the calibration circuit. Reference voltages for Tests 1 and 2 are approximately 7 percent of full-scale metering values. The value of resistor R6 is selected at assembly to provide a two-thirds scale reading on the line meter for Test 1 and 2 conditions when the circuit is properly adjusted. During calibration the converter circuits are  $\pm$  balanced and calibrated at this 7 percent value. Test switch S2 provides an identical meter scaling for

Table 3-2. REFERENCE SOURCE VOLTAGES FOR CALIBRATION SWITCH

Test Positions	Voltage
1	-5.54 to -6.81 millivolts
2	+5.54 to +6.81 millivolts
3	-5.71 to -5.95 volts
4	+5.71 to +5.95 volts

the neutral converter circuit.\* Test position 3 provides a negative input source equivalent to 2 amperes of line or neutral current to all rms converter circuits. Test position 4 provides a positive reference source equivalent to 2 amperes of line or neutral current to all rms converters. In the calibration procedure, Test 3 and 4 positions are used for  $\pm$  balancing at two-thirds of the full-scale range. Converter circuits are  $\pm$  balanced and calibrated at the two-thirds range position.

The calibration circuit may be compared with the adjustment of a vacuum tube voltmeter circuit as follows:

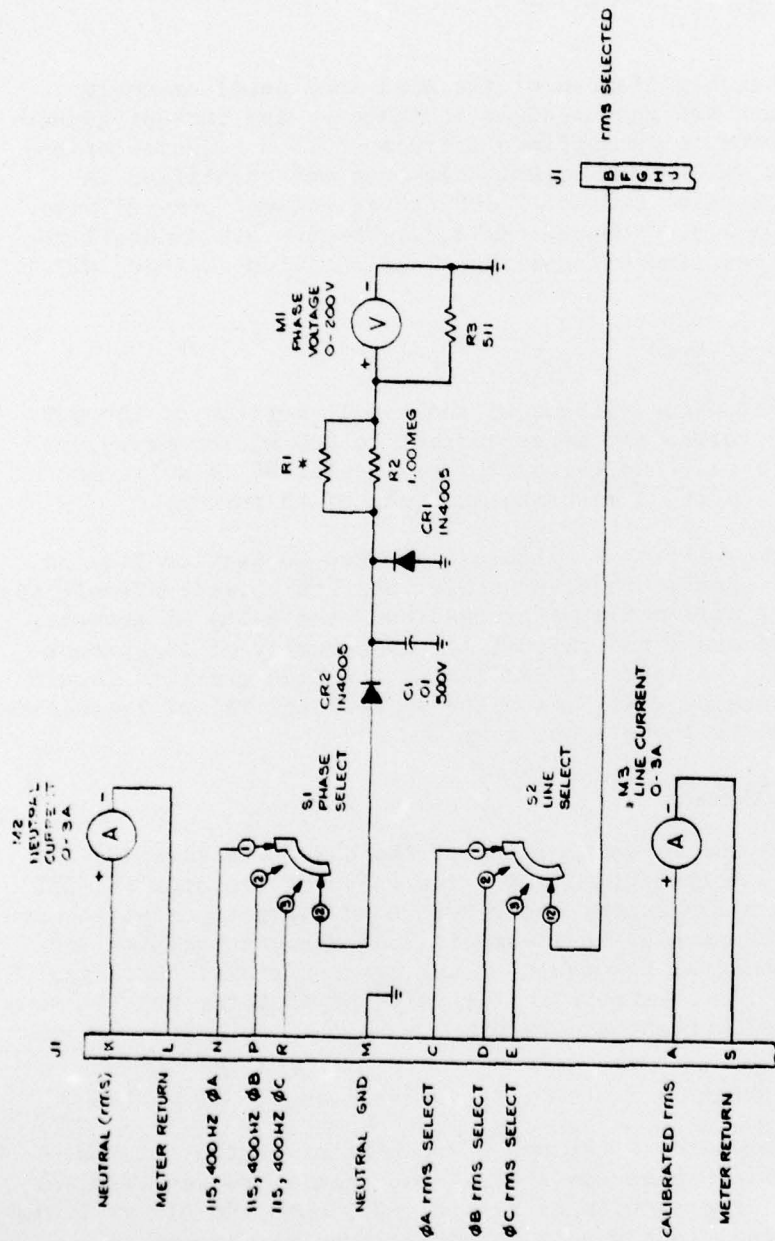
- Adjustments at 7 percent of full-scale values are similar to a zero adjustment.
- Adjustment at two-thirds scale is similar to full-scale calibration.
- 7 percent and two-thirds balancing are required since dc signals are used to simulate ac signals.

Values of resistors R6 and R22 are selected during assembly to scale the line and neutral current meters to indicate 2 amperes for 7 percent current signal input. Similarly, values of resistors R9 and R20 are selected at assembly to provide a  $\pm$ 5 percent of full-scale accuracy in the metering circuit.

### 3.7 Line Monitor Assembly A1A6

Figure 3-8 is a schematic diagram of the line monitor A1A6. Selector switch S1 connects one phase of the 3-phase 400-Hz lines to the voltage monitoring circuit. Diodes CR1 and CR2 rectify the ac input signal. The value of resistor R1 is selected during assembly to calibrate the meter to read 200 volts ac full scale. All DTS meters are 100-microampere full-scale dc meter movements that have an internal resistance of approximately 1,000 ohms. Resistors R2 and R3 are part of the meter scaling circuit.

\*Test switch S2 should only be used when S1 is in the Test 1 or 2 positions. Improper use of this switch may result in damage to the meter movement part of the neutral current circuit.



NOTE:  
 1. RESISTORS MARKED WITH ASTERISK  
 ARE SELECTED DURING CALIBRATION.  
 FOR CALIBRATION PROCEDURES,  
 SEE TP 400.

Figure 3-8. SCHEMATIC OF LINE MONITORING ASSEMBLY A1A6

Switch S2 selects one output of the three line rms converters located on card assembly A1A3A6. The output at J1 pin B is fed back to the A1A3 assembly and scaled to produce 100 microamperes dc through meter M3 for a 3-ampere rms line current. Accuracy of the line current monitor is  $\pm 5$  percent of full scale.

### 3.8 Load Panel A1A5

Figure 3-9 is a schematic diagram of the A1A5 load panel assembly. Functions of the load-bank switches, enable indicators, and current adjustment control were discussed in Subsections 3.5.2 and 3.5.3. The relationship of these devices to other load circuit elements was identified in Table 3-1. Frequency selection switch S7 and the adjustment control were discussed in Subsection 3.2.9. Subsections 3.8.1 through 3.8.4 detail the operation of load panel metering circuits and load shorting switches S17 through S19.

#### 3.8.1 Meter Circuit 5-Volt Load

A meter monitors the output voltage of the 5-volt portion of the UUT. Resistor TB1-R5 sets the full-scale meter current to 100 microamperes,  $\pm 5$  percent, for a 10-volt level. The value of resistor TB1-R6 is selected during calibration to establish a metering accuracy of  $\pm 3$  percent.

The output of meter amplifier A1A3A8U2 (discussed in Section 3.3) is applied to A1A5J1 pin e. Resistor TB1-R3 scales the low current circuit for approximately a 15-ampere full-scale meter reading. The value of resistor TB1-R4 is selected to calibrate the circuit for an accuracy of  $\pm 5$  percent of full scale. Similarly, resistor TB1-R1 scales the high current circuit to read 50 amperes full scale, while the value of resistor TB1-R2 is selected to establish a  $\pm 5$  percent full scale accuracy.

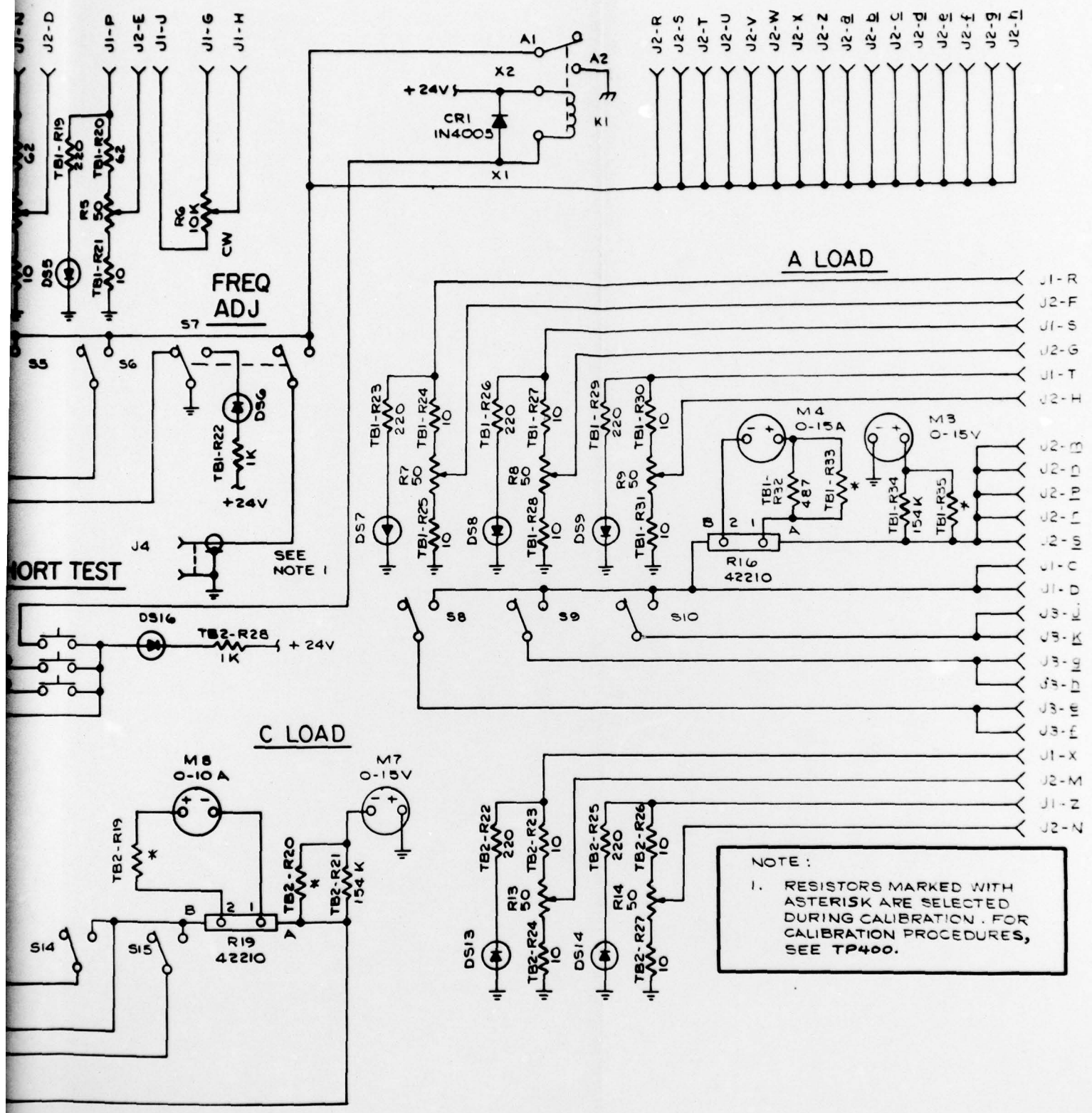
#### 3.8.2 Metering Circuit A-Load

A voltmeter monitors the 12-volt output of the UUT. Resistor TB1-R34 scales the circuit for 15 volts fullscale. The value of resistor TB1-R35 is selected to establish a  $\pm 3$  percent accuracy. Load current passes through the 0.010-ohm precision shunt R16. A 15-ampere load current produces 150 millivolts across the potential terminals of the current shunt. Resistor TB1-R32 scales the meter for 15 amperes. The value of resistor TB1-R33 is selected to establish a  $\pm 3$  percent accuracy.

#### 3.8.3 Other Metering Circuits

Metering circuits for loads B through D are similar to that of the A-Load circuit described in Subsection 3.8.2. Potentials are reversed for negative load circuits. Precision shunt R17 is 0.025 ohms and R19 is 0.010 ohms. Accuracy of all precision shunts is better than  $\pm 1$  percent.





NOTE:  
 1. RESISTORS MARKED WITH ASTERISK ARE SELECTED DURING CALIBRATION. FOR CALIBRATION PROCEDURES, SEE TP400.

Figure 3-9.  
 SCHEMATIC OF LOAD PANEL ASSEMBLY A1A5

2

#### 3.8.4 Load Shorting Circuits

During Test Mode 2 operation, the logic low-current drive signal  $\bar{Q}_2$  is applied through A1A5J1 pin b to enable indicator DS16 and one terminal of shorting switches S17, S18, and S19. Momentary depression of contact switch S17 energizes relay A1A5K1, shorting the 5-volt portion of the UUT. Operation of the SHORT TEST switches and illumination of indicator DS16 is inhibited during Test Modes 1 and 3. When operating in Test Mode 2, depression of switch S18 energizes relay A1A1K7, shorting the 12-volt regulated portion of the UUT. Similarly, depression of momentary-contact switch S19 energizes relay A1A1K8, shorting the -12-volt section of the UUT.

#### 3.9 Control Panel A2A4

Operation of the DTS is controlled by action of the switches on control panel A2A4 (see Figure 3-10). Switch S1, the POWER ON switch, detents the first depressed, holding closed the common and normally open contacts. On second depression, the switch returns to the normal position, breaking the normally open contact and closing the common and normally closed contacts. Switches S2 through S6 are momentary-contact switches.

Placing S1 in the ON position applies the 28-volt dc external source voltage to power relays A1A1K1 and A1A1K5, as addressed in Subsection 3.2.1. The closed contacts of relay A1A1K1 apply 28 volts, illuminating the POWER ON switch indicator. Internal power supplies and the cooling fan are also energized during this ON cycle.

Once the power ON lamp is illuminated, the DTS is placed in the standby mode by momentarily depressing the STBY switch. This action results in application of a low-level logic signal (ground) to the set main (set  $Q_m$ ) latch located on card assembly A1A3 as explained in Subsection 3.2.3.\* A decode standby signal developed on card A1A3A1 and applied to the standby current driver on card A1A3A2 provides a return path, illuminating the STBY indicator portion of the switch.

Test Mode 1 or 2 operation is established by momentarily depressing the TEST 1 or 2 switches. Provided that the main latch  $Q_m$  is set and the OVLD latch  $Q_0$  is not set, a low-level logic signal  $Q_A$  is applied to set  $Q_1$  or set  $Q_2$  input terminals, respectively. The A1A3A2 current driver supplies a return path for illumination of A2A4DS3 (TEST 1 indicator) or A2A4DS4 (TEST 2 indicator), dependent on the mode selected by the operator. In a similar manner, Test Mode 3 operation is initiated by depression of TEST 3 switch and illumination of DS5, except that the A3P3 test connector must be installed previous to Test Mode 3 operation.

The OVLD (red) indicator is illuminated when latch  $Q_0$  is set. A current driver located on A1A3A2 provides the return path for DS6. Momentary depression of the OVLD RESET (red) switch results in application of the

---

\*Refer to Figure 3-1.

low-level logic signal  $\bar{Q}_0$  to the clear input of card A1A3A1. The effect of this signal is to clear  $Q_0$ , resulting in a return to STBY operation.

Switch A2A4S7 selects a three-line 115-volts-per-phase source or a variable three-phase voltage source for driving the UUT. When switch S7 is placed in the VAR position, 24 volts is applied to energize the coil of relay A1A1K4. Figure 3-2 illustrates the distribution of line and variable source voltage. When the DTS is operated in the VAR source mode, switch S8 may be held in the RAISE or REDUCE position, adjusting the input voltage level. This is accomplished by applying 115 volts, 60 Hz to one of the two inputs of a split-phase capacitor motor driving the three-phase variable transformer. Switches mounted on the transformer assembly limit the voltage range from 55 to 160 volts per phase. The voltage input is displayed on the line monitor panel A1A6.

### 3.10 Power Supply A1A2

The power supply assembly A1A2 develops dc voltages used in the DTS. Figure 3-11 is a schematic diagram for the power supply assembly. The  $\pm 12$  volt and  $\pm 5$  volt supplies are commercial units. Details of these are included in the manufacturer's manual in Supplement E of the DTF. Transistor Q1 and associated circuitry comprise the 24-volt dc regulator. Resistor R1 and CR1 form a reference voltage source, which is applied to the emitter-follower Q1 through R2. Input to the regulator is the 28-volt primary source voltage. The principal purpose of this circuit is to limit the transient voltage applied to semiconductor circuits to approximately 25 volts.

Output of the 24-volt regulator is applied to the input of the three-terminal, 15-volt regulator VR1. This supply is used to excite the high threshold logic IC devices.

### 3.11 Overload Protection

The two types of overload protection circuits used in the DTS are the maximum current circuits\* located on the A1A3A7 and the circuit breakers\*\* mounted on the front panel of the A1A1 relay assembly. When operating in Test Modes 1 and 3, 400-Hz line current above 1 ampere will set the overload latch, inhibiting testing. In Test Mode 2, operation is limited to 3 amperes of line current. A 30-millisecond alarm delay is used in these circuits to allow for normal turn-on of transient current flow. The 3-phase circuit breaker rated for 10 amperes is not sensitive to the minor overload limits established by the current limiting circuits. In the event of a low impedance short in the UUT, transient line current (in the order of 50 to 100 amperes) may be experienced. In this event, the 3-phase breaker will open after a few milliseconds. Additional overload protection is provided for Test Mode 3 operation when test cable A3W2 is used. Current limiting resistors of 75-ohm value are placed in series with the 3-phase line applied to the inverter assembly portion of the UUT. For this

---

\*Refer to Subsection 3.2.9.

\*\*Refer to Figure 3-2.

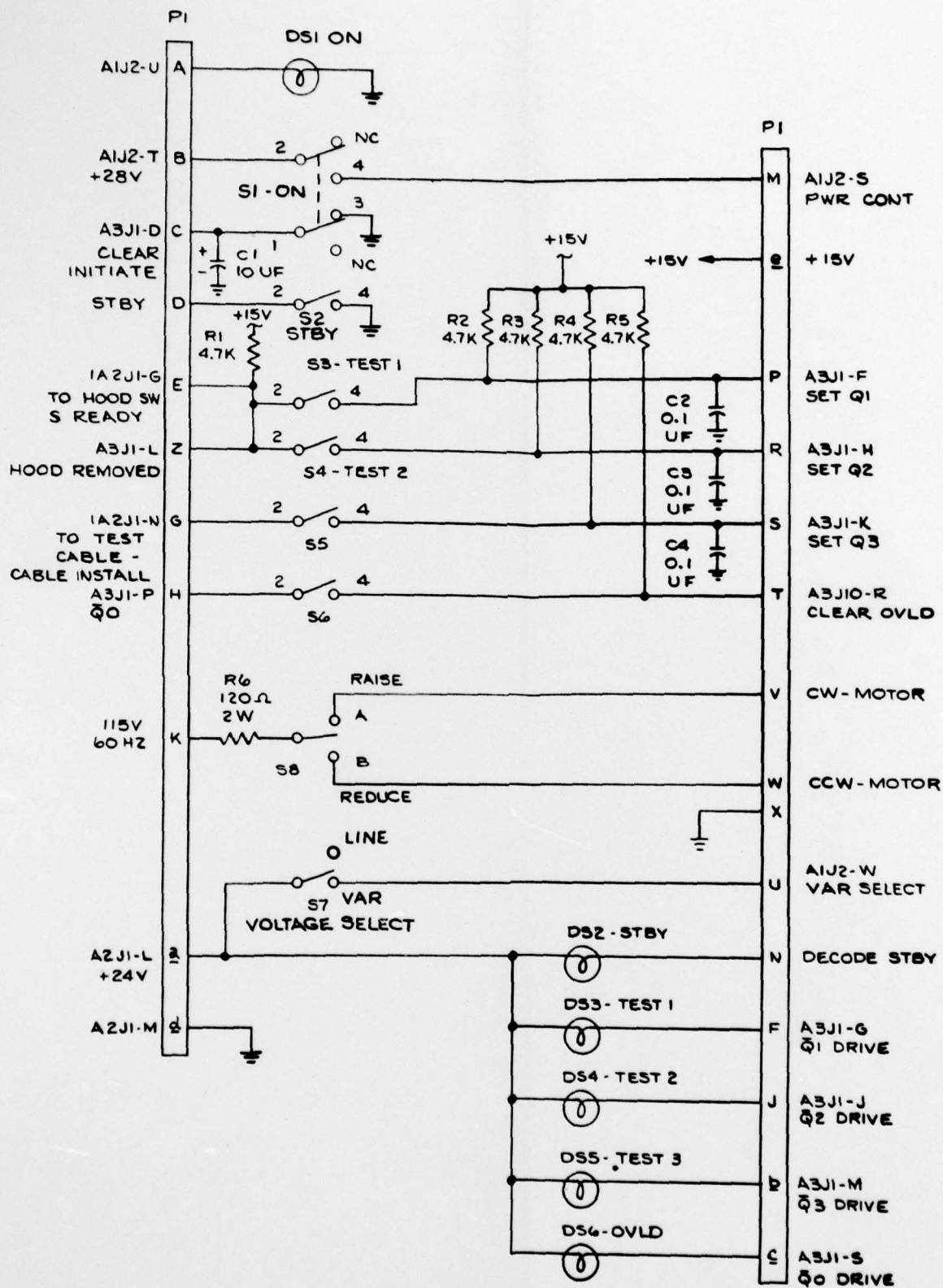
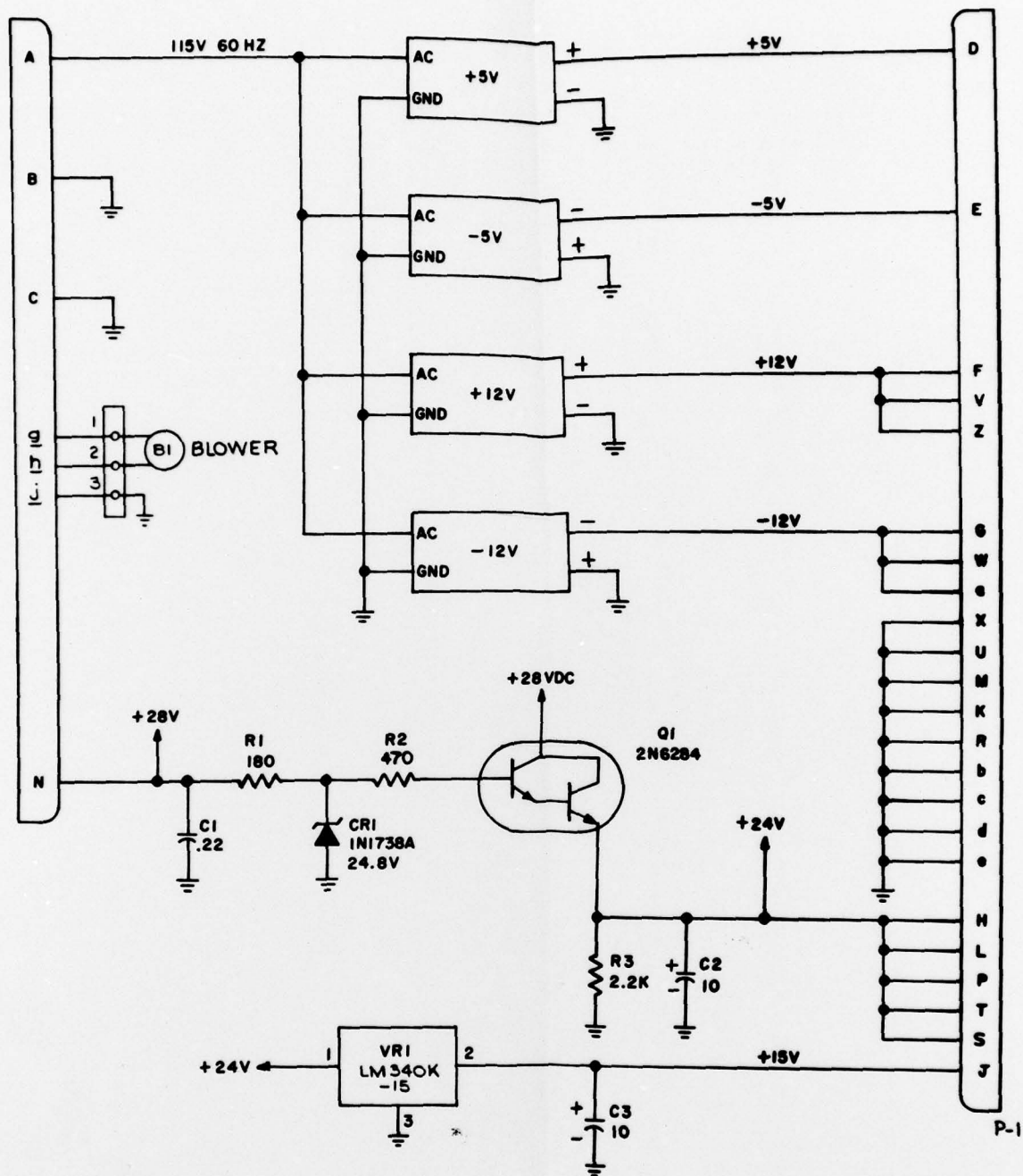


Figure 3-10. SCHEMATIC OF CONTROL PANEL A2A4



- NOTES :
1. UNLESS OTHERWISE SPECIFIED :  
ALL CAPACITOR VALUES ARE IN UF.  
ALL RESISTOR VALUES ARE IN OHMS , 1/4W .
  2. PARTIAL REFERENCE DESIGNATIONS ARE  
SHOWN . FOR COMPLETE DESIGNATION PREFIX  
WITH UNIT , ASSEMBLY, AND SUBASSEMBLY  
DESIGNATIONS .

Figure 3-11. SCHEMATIC OF POWER SUPPLY ASSEMBLY A1A2

additional protection, the normal power supply connectors A3J1 and A3P1 must be connected to test cable A3W2. Under this condition, the series resistors limit the 3-phase line current to approximately 1.5 amperes.

In the event of a short or defective semiconductor in the inverter assembly, operation will be terminated in approximately 30 milliseconds, since the 1-ampere maximum current sensing is used in Test Mode 3. This additional protection in Test Mode 3 prevents damage to inverter parts that could occur as a result of incomplete repair action.

#### 4.0 INSTALLATION, REMOVAL, AND ASSEMBLY/DISASSEMBLY INSTRUCTIONS

##### 4.1 Moving Instructions

The Dynamic Test Set (DTS) is delivered as an integral assembly mounted on casters for easy relocation. Primary power for the DTS is provided through three standard utility connectors located on the upper left hand corner of the A1 assembly.

The DTS may be rolled on its casters from place to place as long as steps are not encountered. Once the unit is in place, it can be made operational by plugging the connectors into suitable utility connectors for primary power (115 volts, 3-phase, 400-Hz; 28 volts dc; and 115 volts, single-phase, 60 Hz).

##### 4.2 Disassembly/Assembly

The DTS is designed for easy removal of the major subassemblies. The equipment rack assembly (A1), equipment cabinet assembly (A2), test bench assembly (A3), and storage drawers can be separated by removing attaching screws and disconnecting mating connectors where necessary.

Small subassemblies, e.g., chassis and drawers, may be removed for mounting without disassembling the major assemblies.

Disassembly of the smaller subassemblies is described in Subsections 4.2.1 through 4.2.13. Disassembly of the major assemblies is described in Subsections 4.2.13 through 4.2.15.

###### 4.2.1 Relay Assembly (A1A1)

The relay assembly is mounted on slides. It can be removed by:

- Disconnecting the cable connectors and ground
- Removing the front panel screws
- Withdrawing the assembly to the full extent of the slides
- Releasing the slide locks
- Removing the chassis

Replacement can be accomplished in the reverse order.

#### 4.2.2 Power Supply Assembly AlA2

The power supply assembly is mounted on slides. It may be removed by:

- Disconnecting the cable connectors and ground
- Removing the front panel screws
- Withdrawing the assembly to the full extent of the slides
- Releasing the slide locks
- Removing the chassis

Replacement can be accomplished in the reverse order.

#### 4.2.3 Card Assembly AlA3

The card assembly is mounted on slides. It may be removed by:

- Disconnecting the cable connectors and ground
- Removing the front panel screws
- Withdrawing the assembly to the full extent of the slides
- Releasing the slide locks
- Removing the chassis

Replacement can be accomplished in the reverse order.

#### 4.2.4 Blower Assembly AlA4

The blower assembly is hard-mounted to the equipment rack and to the ducts. To remove the assembly:

- Remove the 8 sheet metal screws that attach the duct to the blower
- Disconnect the power connector
- Remove the filter cover from the front of the assembly, thus exposing the filter and the front panel screws
- Remove the front panel screws
- Remove the unit from the front

Replacement can be accomplished in the reverse order.

#### 4.2.5 Load Panel Assembly AlA5

The load panel assembly is hard-mounted to the front of the equipment rack. To remove the assembly:

- Remove the cable connectors and ground
- Remove front panel screws

- Pull the front panel assembly out of the rack

Replacement can be accomplished in the reverse order.

Note: Provision is made for troubleshooting this assembly by swinging the panel 90° clockwise and attaching it to the left equipment rack rail with a fixture provided for that purpose (C2528).

#### 4.2.6 Line Monitor Assembly AlA6

The line monitor assembly is hard-mounted to the equipment rack. To remove the assembly:

- Disconnect cable connectors and ground
- Remove the front panel screws
- Remove the assembly from the front

Replacement can be accomplished in the reverse order.

#### 4.2.7 Calibration Assembly AlA7

The calibration assembly is hard-mounted to the equipment rack. It can be removed to gain access to the calibration controls as follows:

- Disconnect the cable connector and ground
- Remove the cover
- Remove the front panel screws
- Lift the assembly up through the top of the equipment rack rails

Replacement can be accomplished in the reverse order.

#### 4.2.8 Load Assembly AlA8

The load assembly is hard-mounted to the equipment rack. The load panels containing all the electronic assemblies may be removed individually as follows:

- Disconnect the cable connectors and ground
- Loosen the quick disconnect fasteners around the periphery of the panel
- Lift the panel out of the load assembly

Replacement can be accomplished in the reverse order.

#### 4.2.9 Transformer Chassis Assembly A1A9

The transformer chassis assembly is hard-mounted to the equipment rack. It may be removed by:

- Removing the cable connector and ground
- Removing the 12 mounting screws that mount it to the equipment rack
- Lifting the assembly up and out through the back door

Replacement can be accomplished in the reverse order.

#### 4.2.10 Differential Voltmeter A2A1

The differential voltmeter is hard-mounted to the equipment rack. To remove the voltmeter:

- Disconnect the power connector and ground
- Remove the front panel screws
- Lift the voltmeter out through the front panel

Replacement can be accomplished in the reverse order.

#### 4.2.11 Patch Panel A2A2

The patch panel is hard-mounted to the equipment rack. To remove the panel:

- Disconnect the power connector and ground
- Remove the front panel screws
- Lift the voltmeter out through the front panel

Replacement can be accomplished in the reverse order.

#### 4.2.12 Oscilloscope Assembly A2A3

The oscilloscope assembly is mounted on slides. To remove the assembly:

- Disconnect the power cable and ground
- Remove the front panel screws
- Remove the assembly from the front of the equipment rack

Replacement can be accomplished in the reverse order.

#### 4.2.13 Control Panel Assembly A2A4

The control panel assembly is hand mounted to the equipment rack. To remove:

- Disconnect the cable connectors and ground
- Remove the front panel screws
- Remove the assembly from the front of the equipment rack

Assembly may be accomplished in reverse order.

#### 4.2.14 Equipment Rack Assembly A1

The equipment rack assembly A1 may be removed from the remainder of the system as follows:

- Disconnect the two interconnecting cable connectors
- Disconnect all grounds from the cold plate
- Remove attaching screws from the inlet and return parts of the air duct
- Remove four bolts that attach A1 to A2
- Remove bolts that attach table legs to the A1 assembly
- Remove A1 assembly

Replacement can be accomplished in the reverse order.

#### 4.2.15 Equipment Cabinet Assembly A2

The equipment cabinet assembly A2 can be removed as follows:

- Disconnect connectors from the A1 and A2 assemblies
- Disconnect grounds from the cold plate to the A2 assembly
- Remove bolt connecting the A1 and A2 assemblies
- Remove the four bolts that connect the A2 assembly to the cold plate
- Remove the A2 assembly by pulling up and toward the front

Note: Do not disconnect the A2 assembly from the base.

Replacement can be accomplished in the reverse order.

#### 4.2.16 Test Bench Assembly A3

The test bench assembly A3 can be removed by removing the A1 and A2 assemblies (see Subsections 4.2.14 and 4.2.15).