

AD-A074 902

CONSTRUCTION ENGINEERING RESEARCH LAB (ARMY) CHAMPAIGN IL F/G 13/13
DECOR GUIDE FOR ENLISTED PERSONNEL DINING FACILITIES. (U)

JUL 79 R L PORTER, B D BERSHAD, N HINTZ
CERL-TR-E-150

IAO-DRXNM-76-174
NL

UNCLASSIFIED

1 OF 2

AD
A074902

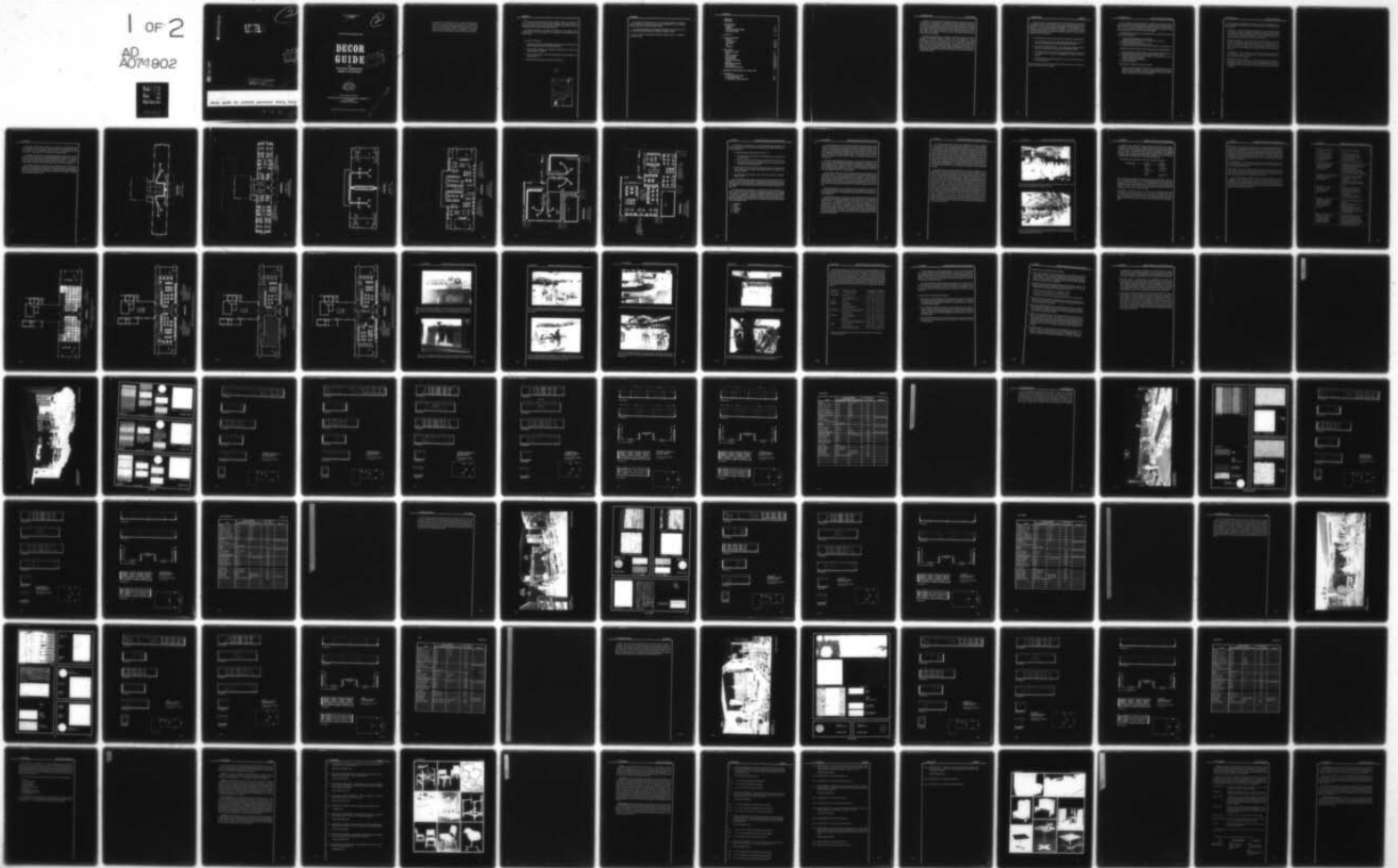

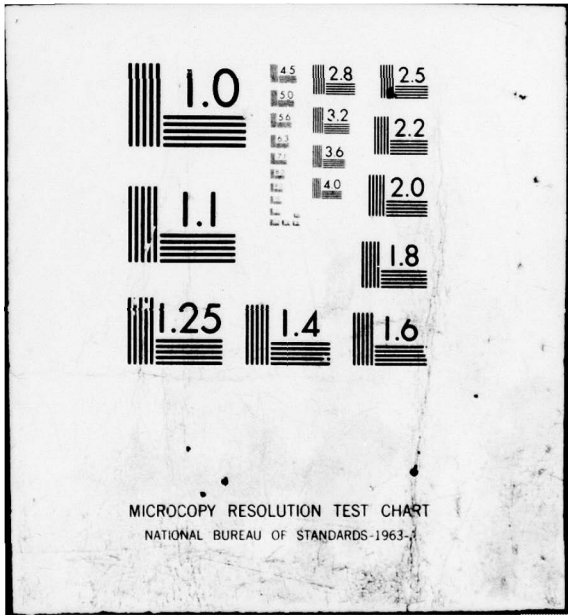

2

ADAU74902

LEVEL ~~XXXX~~

DDC
RECEIVED
OCT 11 1979
REGISTRY
E

DDC FILE COPY

A003828

This document has been approved
for public release and sale; its
distribution is unlimited.

OPTIONAL FORM NO. 10
MAY 1962 EDITION
GSA FPMR (41 CFR) 101-11.6

decor guide for enlisted personnel dining facilities

79 10 09 095
79 10 09 095

9
Technical Report E-150
July 1979
11

12 146

2

UNITED STATES MARINE CORPS

14
CERL-TR-E-150

6

DECOR GUIDE

for
ENLISTED PERSONNEL
DINING FACILITIES.

DDC
RECEIVED
OCT 11 1979
E

15 IAD-DRXNM-76-374

10
Prepared by
Robert L. Porter,
Blaine D. Bershad,
MAJ Norman Hintz
Jeffrey S. Mark

US ARMY CORPS OF ENGINEERS
CONSTRUCTION ENGINEERING RESEARCH LABORATORY
P.O. Box 4005
Champaign, Illinois 61820

Approved for public release; distribution unlimited.

405 279

ORIGINAL CONTAINS COLOR PLATES; ALL DDC
REPRODUCTIONS WILL BE IN BLACK AND WHITE.

mit

The contents of this guide are not to be used for advertising, publication, or promotional purposes. Citation of trade names does not constitute an official endorsement or approval of the use of such commercial products. The contents of this guide should not be construed as an official Department of the Army position unless so designated by other authorized documents.

ABSTRACT

↘
This guide presents coordinated interior design concepts and criteria for Army Food Service Officers and Facilities Engineers. The implementation of these concepts and criteria is illustrated with a renovation case study of a Marine Corps dining facility at Marine Corps Base, 29 Palms.

The design information in the guide is intended to improve dining facility environments by eliminating drabness, noise, the appearance of crowdedness, and lack of privacy.

Included in this guide are:

1. Example dining facility modernization floor plan layouts, including a renovation case study at Marine Corps Base, 29 Palms.
2. Typical design packages with perspective renderings, color options, and implementation worksheets.
3. Furniture and accessory index with discussions, photos and specific listings of materials.
4. Worksheets and cost data with contract information. ←

- A

Accession For	
NTIS GAMA1	<input checked="" type="checkbox"/>
DDC TAB	<input type="checkbox"/>
Unannounced	<input type="checkbox"/>
Justification _____	
By _____	
Distribution/ _____	
Availability Codes	
Dist	Avail and/or special
A	

FOREWORD

This research was conducted for U.S. Army Natick Research and Development Command under Intra-Army Order Number DRXNM 76-174. The Technical Monitors were Mr. P. Brandler and Mr. M. Davis.

This guide was prepared by the Energy and Habitability Division (EH), of the U.S. Army Construction Engineering Research Laboratory (CERL).

Col. J. E. Hays is Commander and Director of CERL and Dr. L. R. Shaffer is Technical Director.

CONTENTS

ABSTRACT	
FOREWORD	
1 INTRODUCTION	
Background	1-1
Purpose	1-2
Overall Renovation Process	1-3
Use of Decor Guide	1-4
2 LAYOUTS	2-1
3 DESIGN PACKAGES	
"Patterns"	3-1
"Contemporary"	3-11
"Ski Lodge"	3-19
"Pub"	3-27
"European"	3-35
4 ITEM INDEX	
General Information	4-1
Chairs	4-3
Tables and Booths	4-7
Floor Coverings	4-13
Wall Coverings	4-19
Partitions and Drapery	4-23
Lighting	4-25
Decorative Accessories	4-29
Sound System	4-35
Miscellaneous Equipment	4-37
5 BUDGETING WORKSHEETS and PRICE LIST	5-1
6 APPENDICES	
A: Decor Design Principles	6-1
B: Maintenance Tips	6-4
C: References and Manufacturers	6-6

1 INTRODUCTION

The decor of a dining facility includes both aesthetic character and functional arrangement. The favorable or unfavorable effect on the customers depends on how the facility was designed, and how well that design was executed. Favorable responses can be obtained by carefully coordinating the temperature and humidity, sound intensity, light quality, seating options, degree of privacy, and colors, sizes, shapes, proportions, and rhythms of the finishes and furnishings. All of these factors work together to affect the customer's attitude toward the Marine Corps food service program.

Renovating a dining facility is intended to improve the customer's dining environment by alleviating drabness, excessive noise, the appearance of being crowded, and the lack of dining privacy. The total environment also involves many aspects of food service other than decor: i.e., customer service, food-preparation, maintenance, and operational policies. Since the local conditions of the facility may also dictate certain special design considerations, the services of an experienced interior designer should be used with this guide. Such assistance in implementing construction documents and supervision of the work should insure a high-quality product.

This guide has been prepared specifically to assist installation-level personnel in implementing new interior designs for dining areas of enlisted personnel dining facilities and to serve as a planning and design guide for developing specific solutions from a variety of coordinated decor packages. It is not intended to supersede Marine Corps regulations, directives, standards, or specifications, but rather to stimulate design ideas and establish a high level of quality in the environments of Marine Corps dining facilities.

To accomplish this purpose, the guide has been organized into four sections:

1. The LAYOUTS section, which has typical dining facility floor plans, including a renovation case study at Marine Corps Base, 29 Palms.
2. The DESIGN PACKAGES section, which has design packages including perspective renderings, color options, and implementation charts.
3. The ITEM INDEX section, which has recommended furniture and accessory selections with discussions, photographs, and specific listings of materials.
4. The WORKSHEETS AND PRICING section, which has cost data and procurement information.

Before the guide is used, the overall renovation process indicated in the following section should be carefully considered.

Only by combining the expert efforts of persons who are familiar with the specific conditions of the local installation will a renovation project be successful. Certain skills and responsibilities should be defined from the outset of each project, in order to avoid unnecessary coordination problems and delays. These responsibilities generally fall into the following categories:

COORDINATOR (Installation Food Service Officer, Dining Facility Manager, and/or Facilities Engineer)

1. Accepts overall responsibility for the project
2. Determines applicable Marine Corps regulations and documents
3. Obtains and administers funds
4. Provides evaluation of existing dining facility
5. Determines scope and priorities of work, and oversees its implementation.

DESIGN/TECHNICAL CONSULTANT (Designer and/or Facilities Engineer)

1. Determines scope of technical work; e.g., wiring, special construction, etc.
2. Draws plans and layouts and writes specifications for this work
3. Adapts recommended plans, design schemes, and materials to fulfill the needs of the specific installation
4. Acts as a liaison with the contractor
5. Supervises installation.

PURCHASING ADVISOR (Procurement Officer)

Writes all purchase requests according to the requirements of the most recent contracts, and based on quality criteria expressed in Federal Specifications, General Services Administration (GSA) requirements, this decor guide, and the needs of the particular installation.

The four sections of this guide should be used in the following order: (1) LAYOUTS, (2) DESIGN PACKAGES, (3) ITEM INDEX, and (4) WORKSHEETS AND PRICING.

LAYOUTS – First, identify which dining facility is to be improved. Consult the layouts in Chapter 2, especially the Marine Corps Base, 29 Palms study dining facilities that are included. Seating options are provided for each layout. The general functional arrangements of spaces and furnishings can be adapted for the individual facilities that are to be improved.

DESIGN PACKAGES – Next, review the decor styles available in the guide and select a suitable style and color scheme option for each facility to be improved. Each Design Package contains typical interior wall elevations and an Items List page. This Items List is the implementation guide to the Item Index. It lists the *preferred* items for the package, and the Item Index page for each item.

ITEM INDEX – Then, use the Item Index to determine if the material meets the performance needs of the installation; also check the illustration of the item and the ordering information.

WORKSHEETS AND PRICING – Finally, use this section in conjunction with the Item Index. The worksheets aid in computing the specific number of items needed and their costs. The pricing section provides the item price, the purchase type (GSA or commercial), and, if applicable, the contract expiration dates.

2 LAYOUTS

2 LAYOUTS

The three building types presented in this section are existing permanent dining facilities in the Marine Corps. Layout options for each dining facility type are included to serve as guides for placing furniture and determining traffic arrangements. These layouts can be adapted to fit a specific facility.

In situations which allow for two separate dining areas, options are shown for both areas. Each case uses various seating arrangements, partitions, etc., to form "private" seating areas within the dining space. These "private" or "intimate" dining areas are formed where minimum traffic flow exists. A more socially "open" dining atmosphere is developed where major traffic flow is necessary.

An example renovation case study of four buildings at Marine Corps Base, 29 Palms is included starting on page 2-8. The layout options for various seating and serving line alternatives are indicated on both plan drawings and photographs of the renovated facilities. All decor options (Chapter 3) were used in the eight separate dining areas of the base.

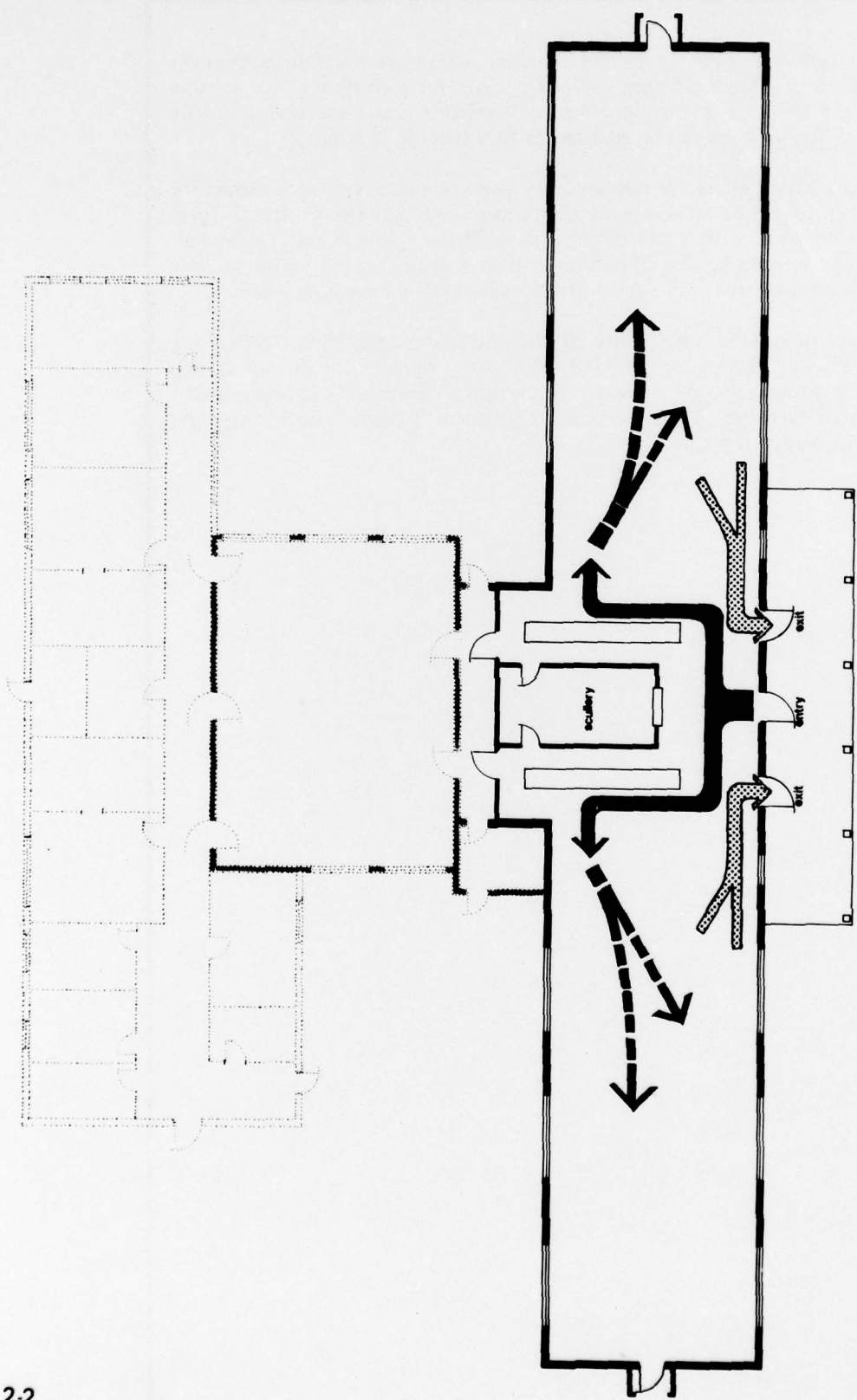

0 5 10 15 20

BUILDING TYPE I
Traffic Flow Diagram

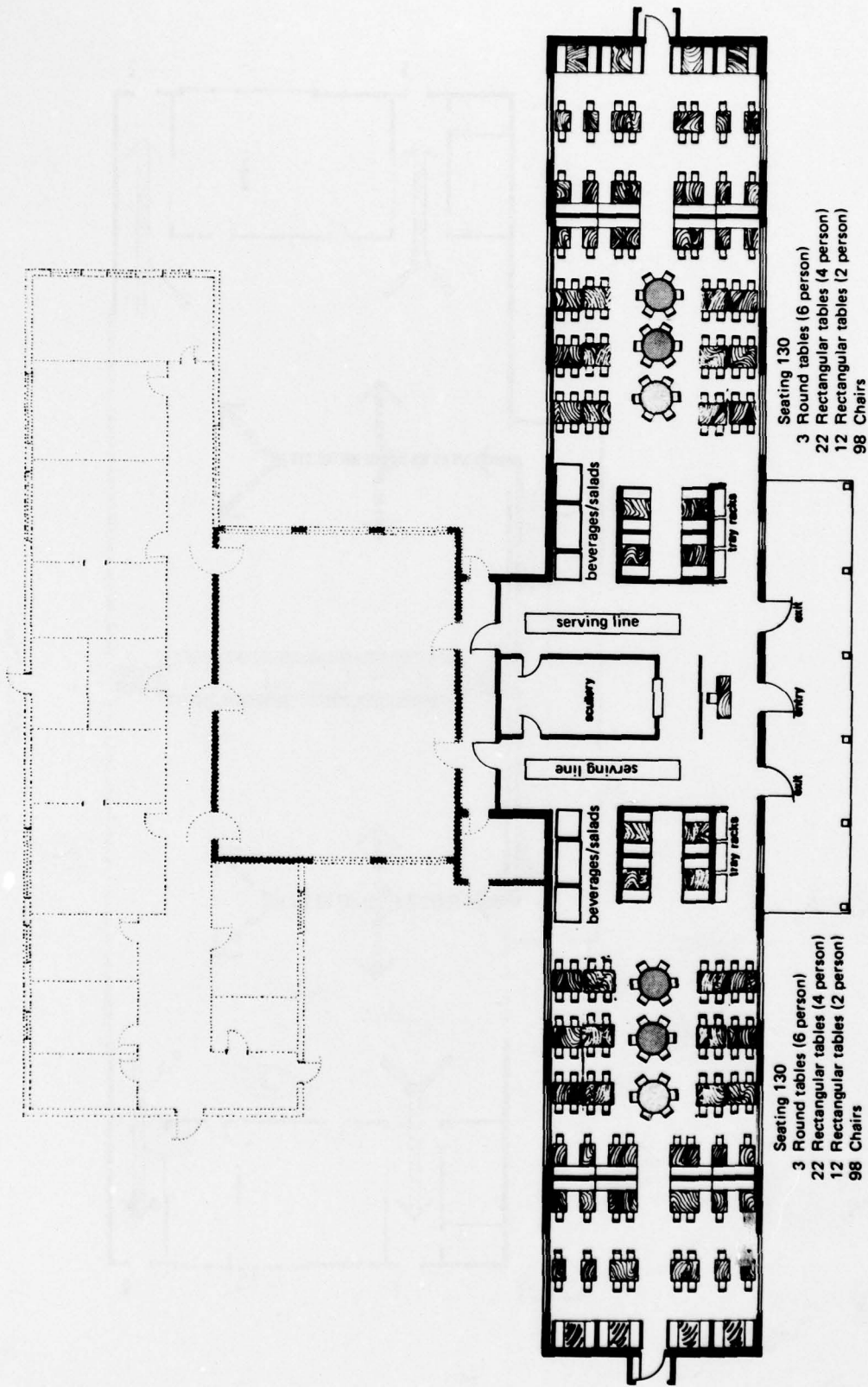

BUILDING TYPE I
Seating Arrangement
Interior Partition Locations

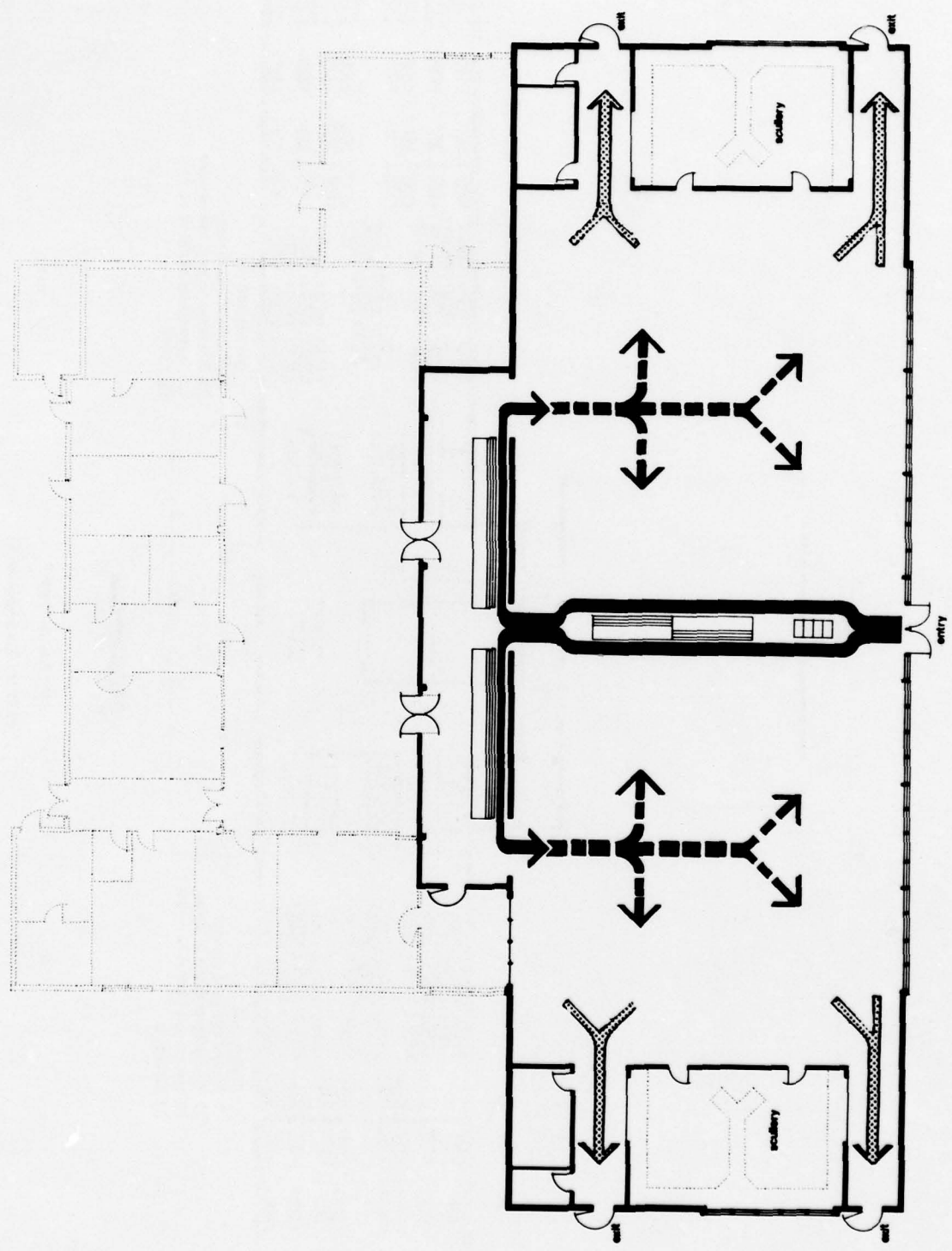

BUILDING TYPE II
Traffic Flow Diagram



Seating — 190
 6 Round tables — 6 person
 32 Rectangular tables — 4 person
 13 Rectangular tables — 2 person
 112 Chairs

Seating — 184
 4 Round tables — 6 person
 32 Rectangular tables — 4 person
 16 Rectangular tables — 2 person
 106 Chairs

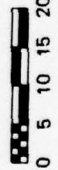

BUILDING TYPE II
 Seating Arrangement
 Interior Partition Location

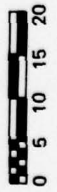
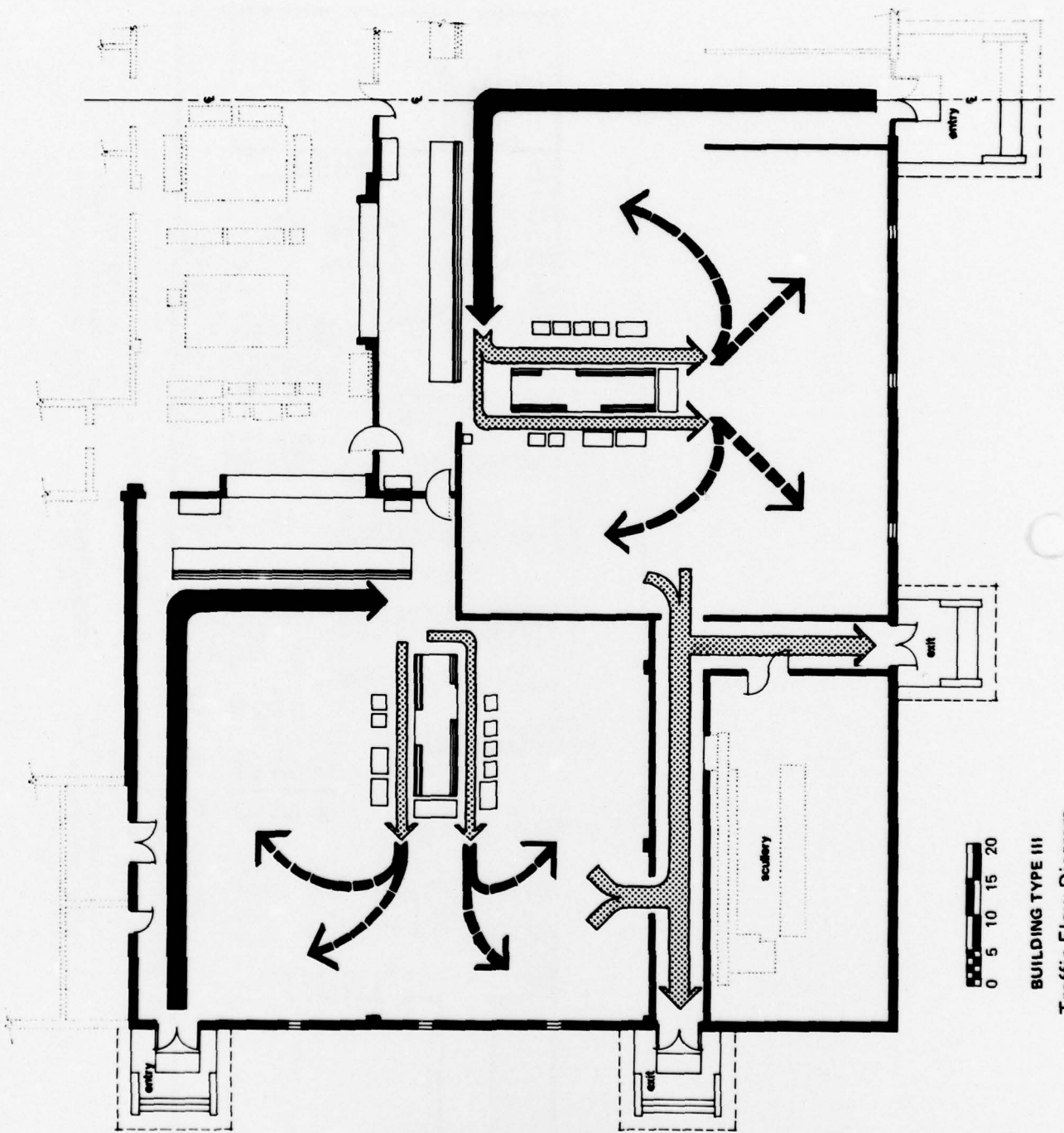

BUILDING TYPE III
Traffic Flow Diagram

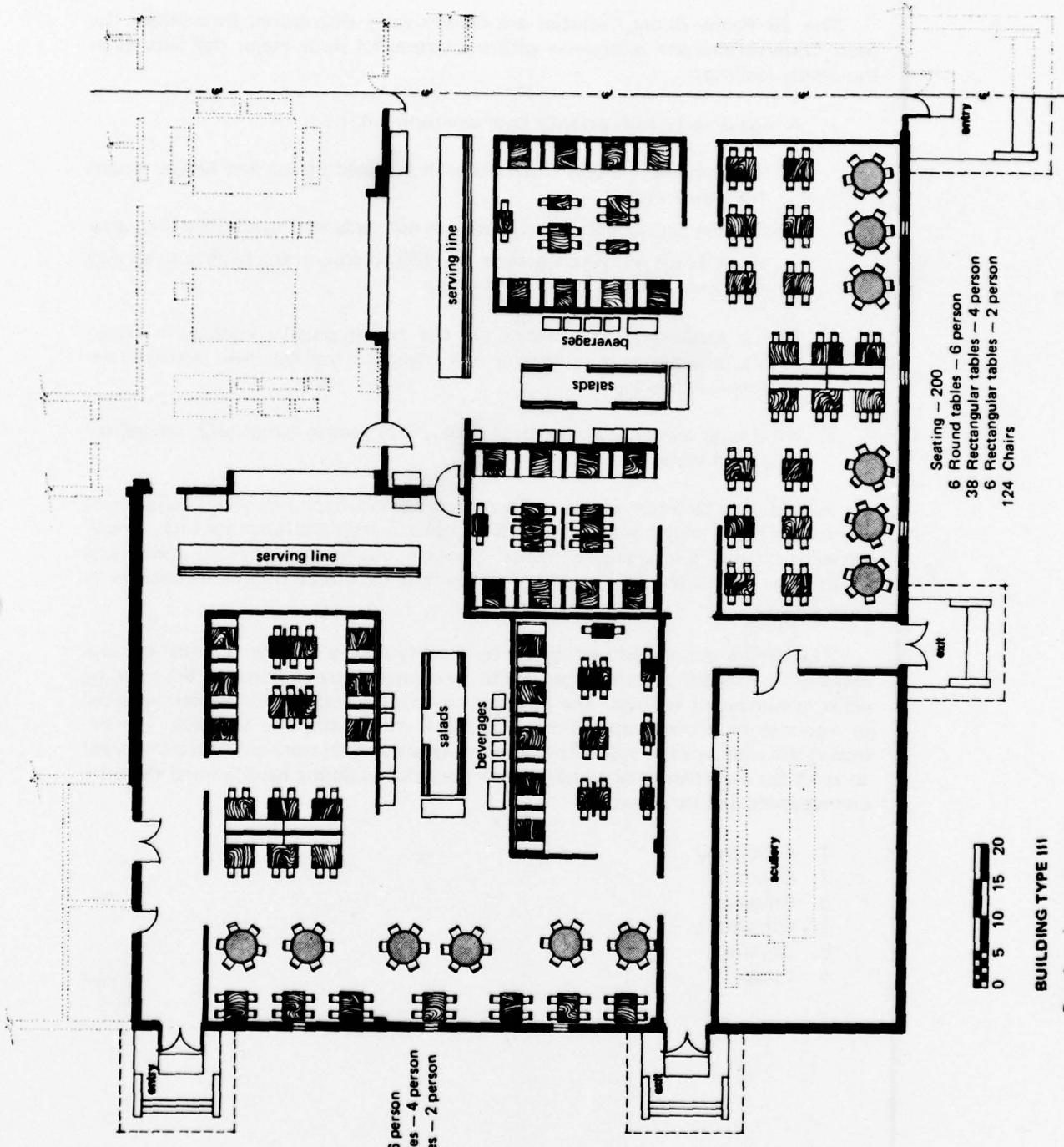

Seating - 164
 6 Round tables - 6 person
 27 Rectangular tables - 4 person
 10 Rectangular tables - 2 person
 108 Chairs

Seating - 200
 6 Round tables - 6 person
 38 Rectangular tables - 4 person
 6 Rectangular tables - 2 person
 124 Chairs



BUILDING TYPE III
 Seating Arrangement
 Interior Partition Location

The 29 Palms dining facilities are conveniently distributed throughout the base. Observations and interviews with users revealed three major deficiencies in the dining facilities:

1. A high density/high activity level environment; i.e.:
 - a. The serving line was cluttered with exposed piping and hanger chains for light fixtures
 - b. Serving and scullery line traffic was not separated from the dining area
 - c. No privacy was possible since the 400 persons in the facility or serving line were within view of each other.
2. Dining space did not differentiate the dining activity from work experiences, whereas new residences and academic facilities have activity-relevant environments.
3. All dining seating was identical, fixed, four-person tables with nonadjustable shell seats.

Four dining facilities were chosen for renovation. Each renovated facility was divided into two major seating areas for approximately 150 persons each, to create eight distinct dining environments. (Photographs of prerenovation conditions are on page 2-11; a layout plan of one of the four facilities before renovation is on page 2-16.)

The dining areas were renovated by modifying the *interior* physical components of the facilities. Other than paint, no changes were required to the building walls, windows, or ceilings. The physical component modifications were selected in response to preferences indicated by the Marines using the facilities. The following six categories of typical habitability requirements were considered relevant to both the environmental conditions of the existing dining facilities and the preferences indicated by users:

1. Efficiency
2. Choice
3. Privacy
4. Sociability
5. Comfort
6. Image

Two of the eight areas in the renovated buildings used the existing four-person tables with attached seats. The other six dining areas used various seating areas. "Private" dining areas were formed where minimum traffic flow existed; a more "open" dining atmosphere was developed where major traffic flow was necessary. This seating area variation was created by using a furniture layout which provided diners with choices for relative seating privacy, i.e., tables seating from two to six persons, high-traffic, center-of-the-room tables, or low-traffic, perimeter-of-the-room booths.

The layout design isolated the waiting line and serving line areas from the dining spaces. Six-foot-high partitions visually and acoustically screened the lines from the dining areas. To remove the check-in process from the dining space, the layout design included a separate entry area. A double-door entry minimized the fly and airborne sand problem that existed with the prerenovation single-door entry that opened directly into the dining space.

At the check-in entry area, a gap in the partitioning provided diners with a momentary view of the total dining space before they were channeled into the serving lines. If two or more persons wanted to eat together, yet chose different menus from the two separate serving lines, they could meet at a table or booth by passing through this same gap in the partitioning. Circulation conflicts between diners entering and leaving were eliminated by separating scullery activity into two areas at the ends of the dining facilities. Each scullery area had a double-door exit.

Since the appearance of a dining facility is the principal visual expression of the food service system, an interior design concept was created to make the facilities visually attractive and to encourage social options which would increase customer satisfaction.

The application of color, in the form of paint, was the least expensive means of significantly changing the appearance of the dining facility. Some walls were brightly painted in proportioned patterns to add visual rhythm and excitement. A neutral color was applied to the ceilings to maintain the reflectivity of the lighting fixtures. The structural concept of the building was emphasized by applying a darker neutral color to the exposed columns and beams. These contrasting ceilings and cross beams combined with the colorful end wall to psychologically widen a narrow space. The colors of the carpet and other flooring material, drapery decorative accessories, and furnishing materials were coordinated in the development of each scheme.

The design concepts used color as the principal element of decor. However, since the facilities are used for three different meals (morning, noon, and evening), it was desirable to vary the appearance or atmosphere for each meal. This was accomplished with lighting controls. Exterior light was controlled by window draperies and interior light was controlled by light fixtures. Each renovated facility had two different sets of light fixtures—a fluorescent, indirect system which used existing fixtures laid on top of the duct work, and an incandescent system of exposed fixtures along the fascia that enclosed the existing piping for the serving lines. Draperies (recommended at 150 to 200 percent fullness) were used to filter sunlight and to develop the effect of softness and glow within the dining area. Drapery colors complemented the colored wall patterns. Fire-retardant material—an open-weave beta fiberglass or a verel-base fabric—was used. All window treatments were constructed so as not to hamper ventilation or access to window openings.

Seating options are of critical importance to the diner's satisfaction with a dining facility. Diners come to eat, but they also come for friendship. A dining facility must, therefore, accommodate this need. Furthermore, some flexibility must be allowed since the size of diners' social grouping may be as few as two or as many as eight, with three being the most common size. Therefore, an assortment of furniture which is readily adaptable to various seating arrangements was used. Table options included a circular, 54-in.-diameter table for six diners and rectilinear 36 x 48 in. and 24 x 36 in. tables which seated four and two diners, respectively. In addition, rectilinear tables could be combined to seat up to eight diners. All table tops were constructed of durable, hard-surface laminates (non-gloss) and were supported on pedestal bases. (Such bases were necessary to assure easy access to various seating arrangements.) Seating options included both wood and cushioned booths, banquettes (elongated booths), and side chairs to give diners a reasonable sense of comfort and choice. Simply designed seating with durable naughahyde covering was used for easy cleaning and minimum upkeep. Traditional patterns were employed in seating arrangements, with booths facing booths, banquettes facing chairs, and chairs facing chairs. Space allowed for circulation was somewhat more generous than for equivalent seating arrangements in commercial restaurants.



View of the prerenovation condition at serving line. Note galley is open to total dining area and waiting lines are adjacent to tables.



View of the prerenovation condition of the total interior. Note exposed serving line steam piping and ceiling light fixture chains. All users are able to see all others in the entire dining hall at all times.

Excessive noise is common in military dining facilities. Most of the noise is generated by normal activities of the galley, scullery, and the diners themselves. To reduce noise at the renovated dining facilities, the renovation design concepts relied on carpet and generous drapery, partition arrangements that separated functions, and, to a lesser extent, upholstered furniture. Also, where possible, openings in the wall between the kitchen and the serving line were either permanently filled or provided with a door to isolate the galley noise.

Five separate decor "characters" were used in the eight dining areas:

Building Number	Left Side	Right Side
2	Sport Pub	European
3	Patterns	Contemporary
5	Old Southwest Pub	Ski-Lodge
6	Patterns	Early American Pub

PUB — this decor was selected for three areas: one each of Sports, Early American, and Old Southwest taverns. The "Pub" design package uses darker colors and wood furniture with rough textures, with the accent color in the carpet. Wall hangings (carvings, armament plaques, and traditional hunting scenes) give special character to each "Pub" design. Decorative accessories include wall paintings which carry out the theme of the "Pub" decor.

EUROPEAN — this decor is more formal than the other design schemes. Dark colors and ornate wooden furniture are used to create a "European" look. There is a bright accent of blue upholstery color amidst dark wood tones. The carpet pattern complements the furniture details. Several paintings as decorative accessories provide color contrast to the walls and are compatible with the "European" motif.

PATTERNS – the “Patterns” decor was used in the two dining areas where existing tables with fixed seats were retained. This is a contemporary motif which emphasizes color schemes. The existing furnishings within these areas maintain a clean, nonornamental look and are complemented by abstract fabric hangings and painted walls. The painted wall patterns are based on a modular system of interchangeable rectangular panels with reversing colors, in this instance using the red and yellow theme color of the Marine Corps. The dining area end-wall elevations have painted wall patterns.

CONTEMPORARY – the “Contemporary” decor uses simple, straight-line furniture and bright wall colors to produce a clean, light atmosphere. Wall graphics and banners provide strong accents.

SKI-LODGE – the “Ski-Lodge” decor uses wooden furniture with warm, harmonious, earth-tone colors to produce a natural, outdoors atmosphere. Appropriate wall paintings and hangings of outdoor scenes augment the coloring and textures. Also, the exposed beam ceiling is accented in this scheme.

The following table summarizes the main physical components that were modified at the renovated facilities in terms of the six occupant habitability requirements listed on page 2-8. On succeeding pages are the layout plans of a typical Marine Corps Base, 29 Palms dining facility before renovation, and of the four facilities after renovation. These plans are followed by representative photographs of the modified dining facilities.

2 LAYOUTS

MARINE CORPS BASE, 29 PALMS CASE STUDY

Habitability Requirements	Physical Components Modified
<p>EFFICIENCY – where it is easy to find seating, to move around so that diner traffic and work flow do not conflict, etc.</p>	<ul style="list-style-type: none"> ● Established table and booth layout to create obvious traffic-ways from serving line to seating areas, then to scullery. ● Increased available seating places.
<p>CHOICE – where diner can choose among alternative options: a meal portion, a group size, etc.</p>	<ul style="list-style-type: none"> ● Replaced identical tables with attached shell chairs to three table sizes with detached adjustable chairs. ● Installed a "Circle-Serv" so diners can have selection of several portions. ● Installed "scramble" system beverage bar.
<p>PRIVACY – how diner can achieve effect of privacy, of not being crowded, etc.</p>	<ul style="list-style-type: none"> ● Provided vision screens around all dining spaces to separate serving line traffic. ● Located high-back booths to visually separate the dining areas into smaller spaces.
<p>SOCIABILITY – where diner can meet others, have conversations, etc.</p>	<ul style="list-style-type: none"> ● Located larger group tables at high-traffic locations and booths at perimeters for possible isolation from total group. ● Provided two-person tables to constrain others from interrupting.
<p>COMFORT – where visual and acoustical conditions emphasize human requirements, i.e., adjustable furniture, etc.</p>	<ul style="list-style-type: none"> ● Limited harsh noise from galley and scullery. ● Minimized fly and dust entry with double-door vestibules. ● Changed high-contrast glare lighting to indirect reflected ceiling light. ● Provided adjustable, "formed" wood (or padded) seating.
<p>IMAGE – where diner's space is identified in relation to its purpose, and total space (and furnishings) is pleasant to look at, etc.</p>	<ul style="list-style-type: none"> ● Established distinct theme image with coordinated wall and ceiling colors for each area augmented with furnishings and decorative accessories. ● Removed chain hangers from lighting and enclosed serving line piping.

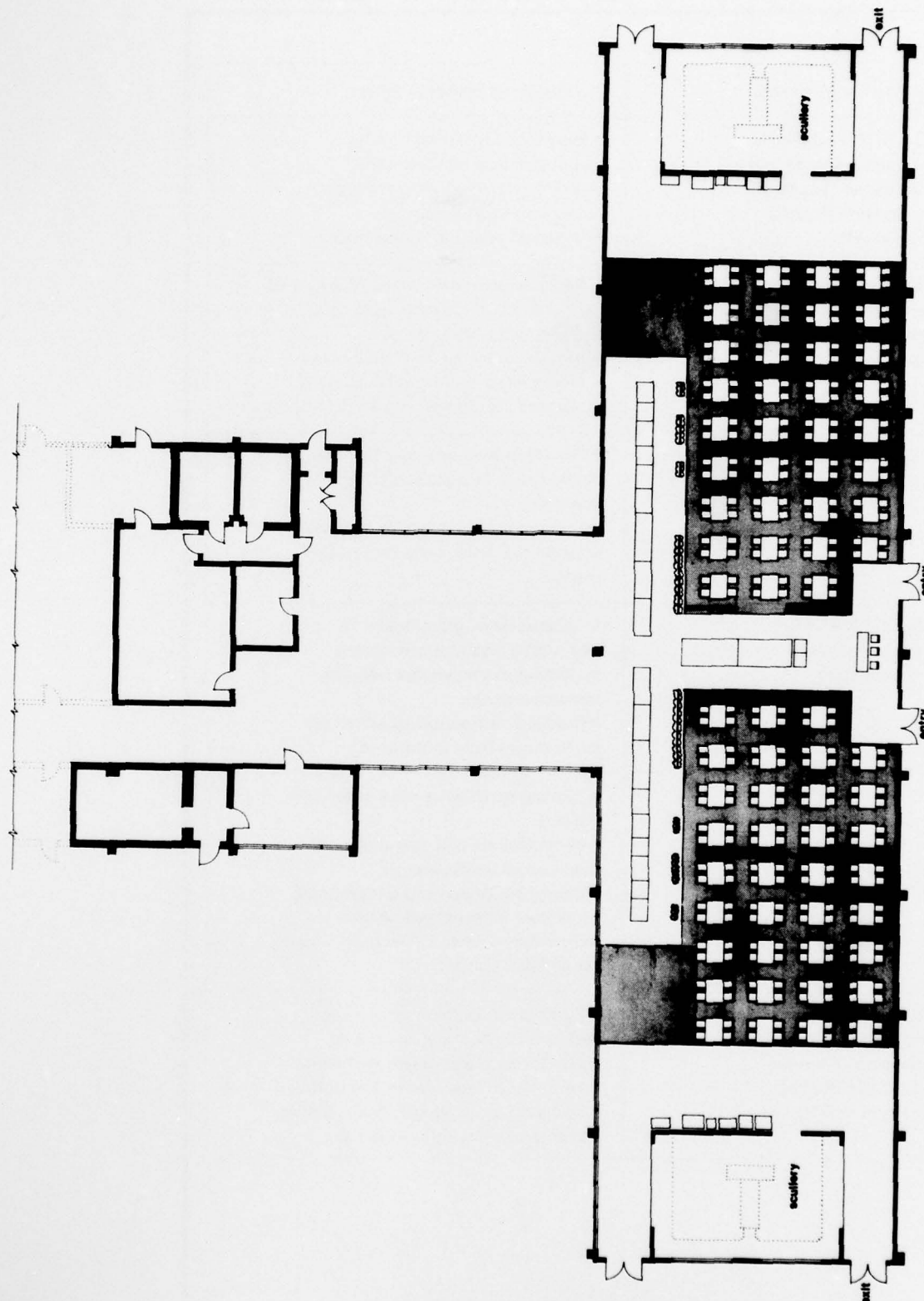

140 seats
 35 - 4 person rectangular tables
 with attached seating

0 5 10 15 20

29 Palms Enlisted Personnel Dining Facility
 (Before F vation)

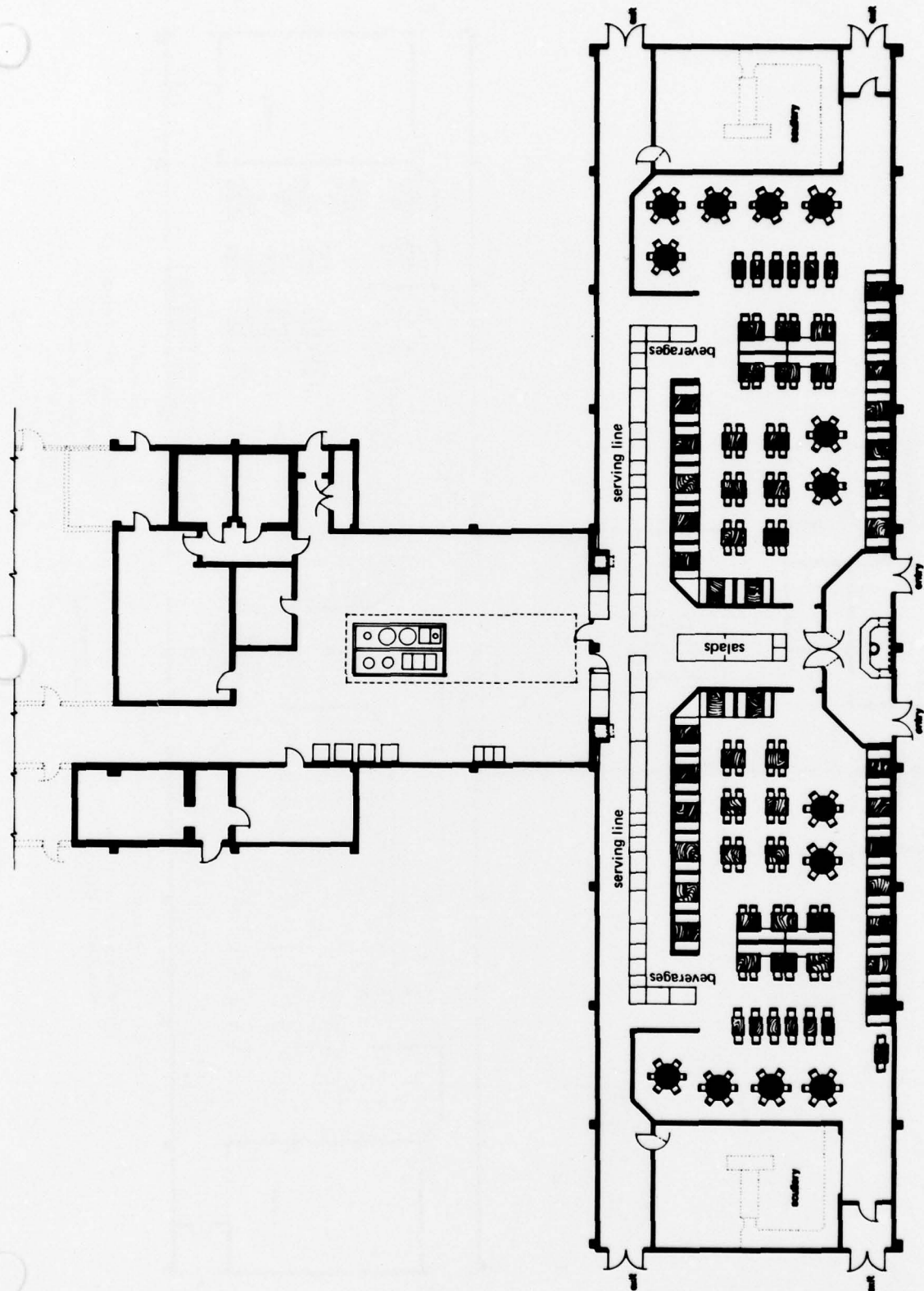

- 158 seats**
- 26 Rectangular tables (4 person)
 - 6 Rectangular tables (2 person)
 - 7 Round tables (6 person)
 - 6 Single booths
 - 11 Double booths
 - 4 Wall booths (8 ft. long)



- 158 seats**
- 27 Rectangular tables (4 person)
 - 7 Rectangular tables (2 person)
 - 6 Round tables (6 person)
 - 6 Single booths
 - 12 Double booths
 - 4 Wall booths (8 ft. long)

29 Palms Enlisted Personnel Dining Facility No. 5

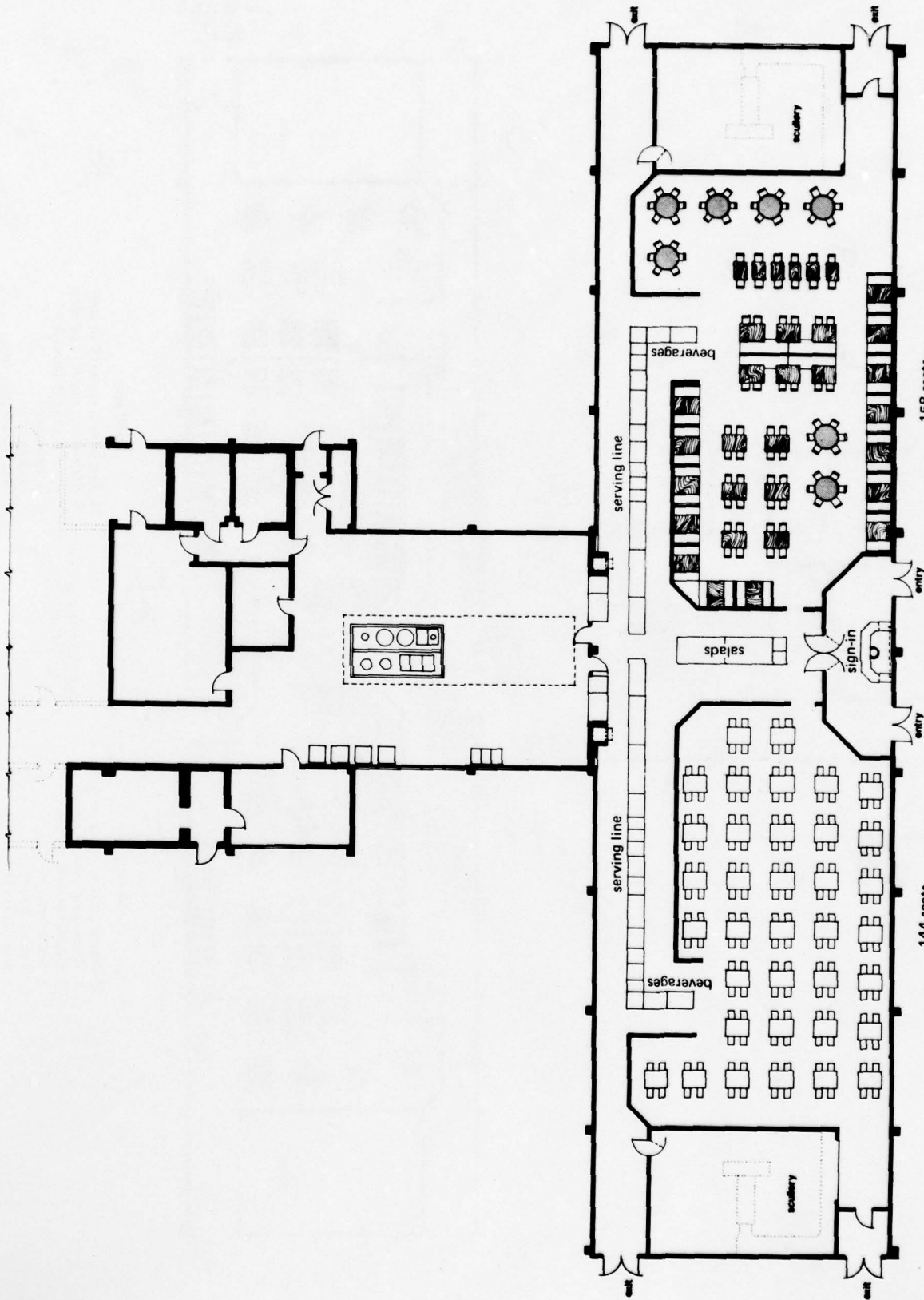

- 158 seats
- 26 Rectangular tables (4 person)
- 6 Rectangular tables (2 person)
- 7 Round tables (6 person)
- 6 Single booths
- 11 Double booths
- 4 Wall booths (8 ft. long)

- 144 seats
- 36 - 4 person rectangular tables with attached seating

29 Palms Enlisted Personnel Dining Facility No. 3 & 6

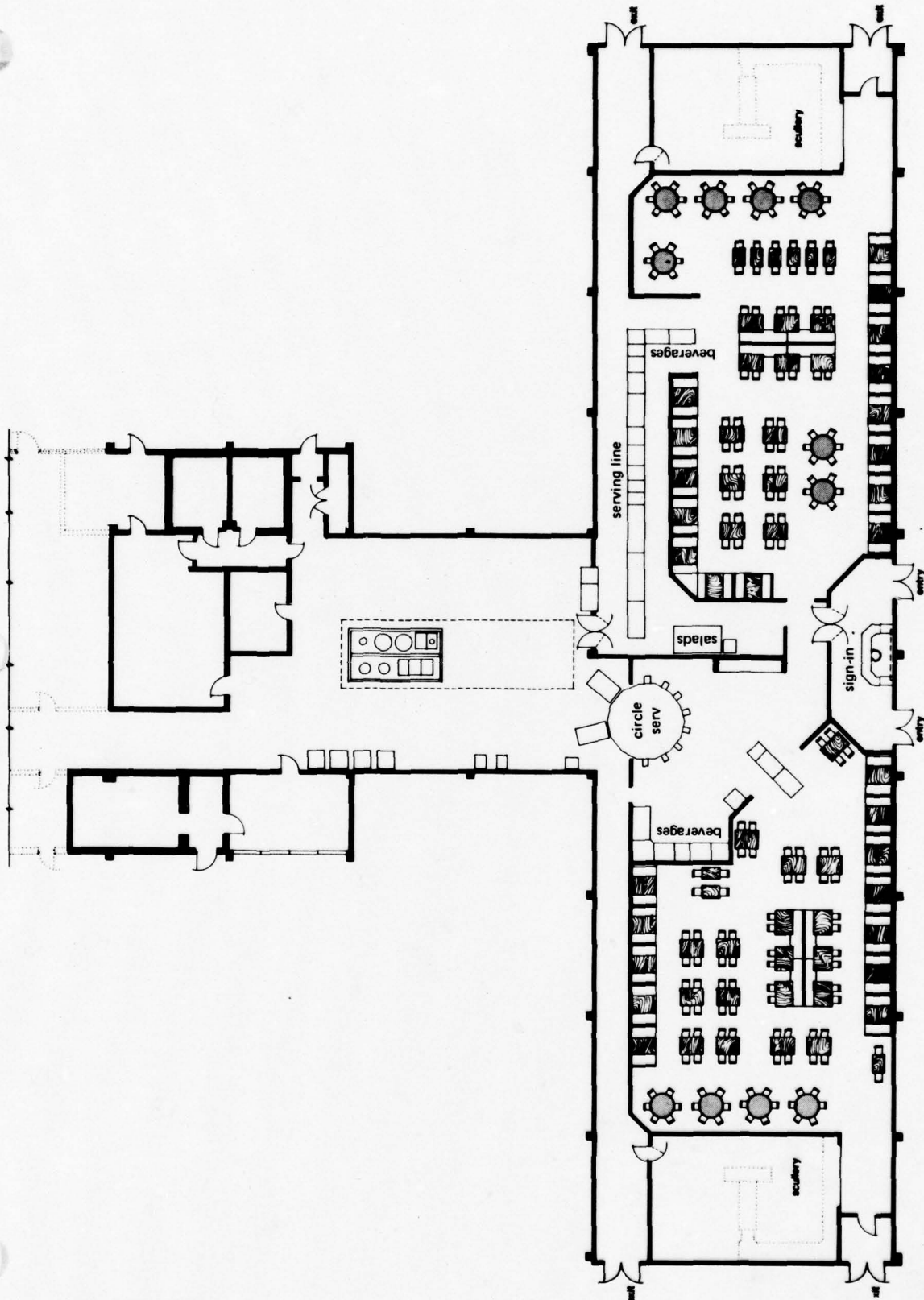

- 162 seats
- 27 Rectangular tables (4 person)
 - 6 Rectangular tables (2 person)
 - 7 Round tables (6 person)
 - 6 Single booths
 - 12 Double booths
 - 4 Wall booths (8 ft. long)

- 150 seats
- 30 Rectangular tables (4 person)
 - 3 Rectangular tables (2 person)
 - 4 Round tables (6 person)
 - 4 Single booths
 - 10 Double booths
 - 4 Wall booths (8 ft. long)



29 Palms Enlisted Personnel Dining Facility No. 2



View of an entry sign and doorway. Each dining area was named so that Marines could refer to their dining facilities in a more food-oriented manner. There is now a choice of at least two buildings (or four dining spaces) on this side of the base.



View of an entry sign and doorway. The names were selected to reflect food specialities. This facility has steak preparation equipment on the serving line.



View of a renovated dining area (Ski Lodge), showing the various choices of table size. The 6-ft-high partition (on the left) separates the dining area from the serving line traffic.



View of a renovated dining area (Sports Pub), showing how carpet colors can be used to separate walking aisles from seating areas. This also allows replacement of high-wear areas at different frequencies from low-wear areas.

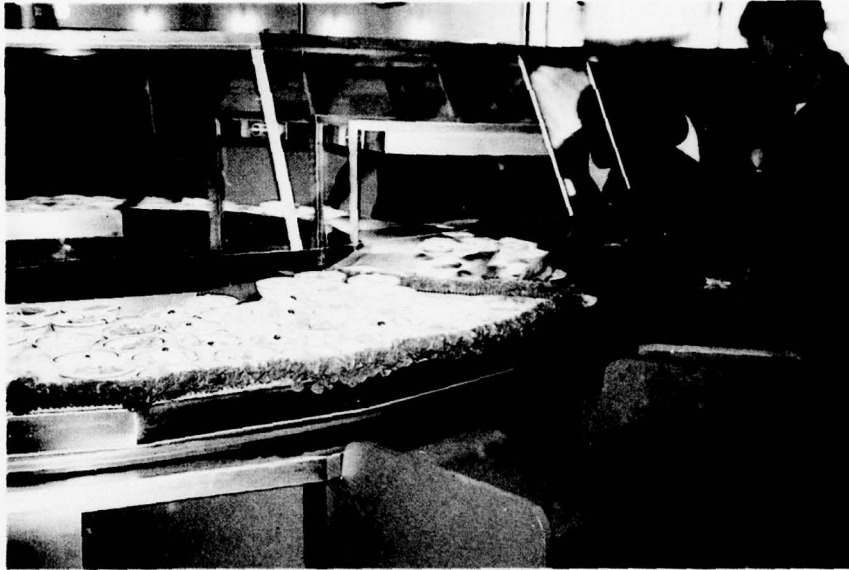

View of the "circle-serv" serving unit. Note extent of food portion choice options.



View of the renovated condition of a typical total interior (Early American Pub). Note how partitions and high booth backs separate the total space into smaller dining areas.



View of the renovated dining area (European), after sign-in at entry, before going down serving line. The 6-ft-high partition separates those standing in line from those at tables or booths.



View of the typical serving line separated from the dining area with a 6-ft-high partition. Note serving line piping enclosure for all horizontal steam lines.

The prerenovation quality of the dining areas was evaluated based on a survey of approximately 500 user/occupants who indicated their attitudes toward the dining facility environments. Of this sample, 67 percent indicated that their dining facility was not an enjoyable place to eat, whereas only 8 percent responded positively. After the physical component modification, only 15 percent indicated that the renovated dining facilities were not an enjoyable place to eat, while 58 percent gave a positive response. The following table includes similar before- and after- renovation responses from the user/occupant survey. Statistically significant percentages indicated the modifications made their dining experiences more satisfactory.

Habitability Requirements	Specific Factors of the Dining Environment	BEFORE		AFTER	
		-%	+%	-%	+%
EFFICIENCY	Finding place to eat	50	34	18	68
	Ease of obtaining meal	38	51	34	57*
CHOICE	Table size	41	50	13	84
PRIVACY	Crowdedness	73	17	30	59
	Separation of activities	58	24	16	74
SOCIABILITY	Visual distraction of other people	40	36	20	64
COMFORT	Chair comfort	67	15	16	73
	Furniture condition	55	23	13	80
	Noise level	45	38	19	64
IMAGE	Visual distraction from physical items	23	49	7	80
	Furniture color	48	27	9	79
	Color throughout the space	57	23	25	50

*Positive response was 68 percent for the dining area in Building No. 2, left side (where "Circle-Serv" was used).

The eight separate dining areas established in the four renovated buildings, each using distinct decor and furnishings, offered an opportunity to develop design guidance based on user/occupant reactions. The following design guidance statements were obtained by analyzing the questionnaire responses of sample groups of 125 Marines who were queried while they were actually experiencing the particular dining environments.

Two types of questions provided data for design guidance: (1) items related to the Marines' basic *dining experience attitudes* (that were not affected by the before or after facility conditions), and (2) items related to the Marines' *dining environment evaluations* (that were significantly affected by the before and after conditions).

Dining Experience Attitude Design Guidance:

- 40 percent of those surveyed said the physical surroundings of dining facilities are relevant to their dining (or meal) enjoyment; therefore, it is important to include relevant user/occupant habitability improvements when upgrading a total food service program.
- 50 to 60 percent said they sometimes wanted to eat alone—with approximately 15 percent highly desiring to do so. This indicates a need for approximately 15 percent of the total seating capacity to be two-person tables, since two-person tables offer the best opportunity to remain alone, or with only one other person.
- Approximately 40 percent said they would like to limit others from seats at their table. This is most easily done with two person tables and with booths for three persons.

Dining Environment Evaluation Design Guidance:

- More than 90 percent of those surveyed said that the table sizes were adequate when a variety of sizes were available and each person had approximately 400 sq in. of table surface. When only four-person tables were available and they had 315 sq in. of table surface each, approximately 35 percent said that the table size was not adequate.
- Even though the number of Marine personnel using each dining area did not change, users/occupants consistently expressed a perception of being less crowded when fewer persons were visible at any one time:
 - 73 percent feel crowded when up to 300+ are visible
 - 40 percent feel crowded when up to 150 are visible
 - 30 percent (and less) feel crowded when groups of 60 to 100 are visible.
- More than 75 percent said that the combination of serving line partitions *and* dining area booth dividers are adequate to isolate movement activities from the more passive dining experience.
- 68 percent responded positively to the introduction of the line "Circle-Serv" and "scramble" beverage bar which provide easier, direct access to food and drink dispensers. The after-renovation survey listed a 53 percent positive response to the conventional serving line.
- When more than 300 persons are visible, approximately the same number of persons are bothered by others "milling about" as those who are not (40 percent each). When serving line traffic is partitioned off, the response shifts to about 25 percent bothered and 50 percent not bothered. When the dining area itself is separated into areas of 60 to 100 persons with booth backs, the response shifts to less than 15 percent bothered and about 75 percent not bothered.
- Almost 96 percent of those surveyed said that padded chairs were very comfortable for dining, and approximately 75 percent responded positively to the "formed" seat and back wood chair as being very comfortable. Therefore, if damage to padding is a major maintenance problem, the "formed" wood chair

is acceptable by the majority (10 percent of the sample said the "formed" wood chair was uncomfortable, whereas only 1 percent considered the padded chair uncomfortable). The nonadjustable, attached fiberglass shell seats were consistently considered uncomfortable by over 40 percent of those surveyed.

- 90 percent said that furniture color is very satisfactory when wood is the dominant material — either real wood on booths and chairs, or plastic wood-like laminate on table tops. Neither light nor dark wood grain colors, nor blue, red, or brown upholstery colors seem to make any difference in user preference. Solid color fiberglass furniture in prerenovated facilities was considered very satisfactory by less than 30 percent of those surveyed. After renovation, only 50 percent said the color of fiberglass furniture was very satisfactory.
- There were no functional reasons for noise levels to be significantly different for the various dining facilities after renovation; however, there was a significant difference in occupant response to noise from building to building (*not* area to area in the same building). Approximately 50 percent of those surveyed said the noise level was not bothersome in those buildings with the *lighter* wall and ceiling colors. Approximately 75 percent in those buildings with *darker* wall and ceiling colors indicated the noise level did not bother them. Other studies have also suggested that higher illumination levels tend to cause both the perception of higher sound levels and the generation of higher conversation sound levels.

3 DESIGN PACKAGES

PATTERNS



"PATTERNS" geometric
BUILDING TYPE 64

COLOR OPTION ONE

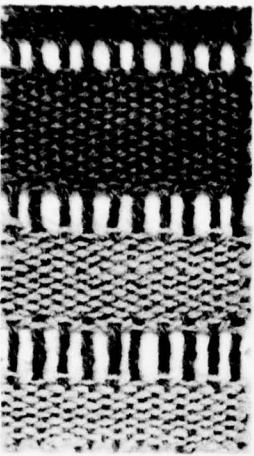

Paint A 35250
Paint B 35183
Paint C 34230
Paint D 37769



Upholstery Naugahyde HG-78



Round Tables Formica 851-64



Rectangular Tables Formica 417-64

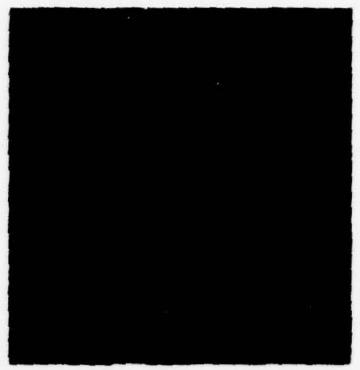

Carpet F-1 Neptune Tweed

OPTION THREE

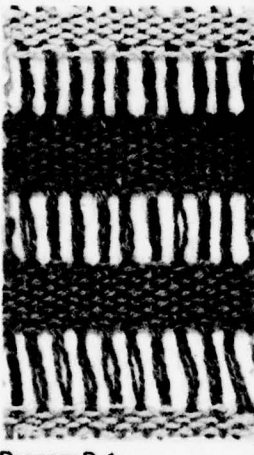

Paint A 33538
Paint B 34151
Paint C 34258
Paint D 37769



Upholstery Naugahyde DC-10



Round Tables Formica 866-64



Rectangular Tables Formica 417-64

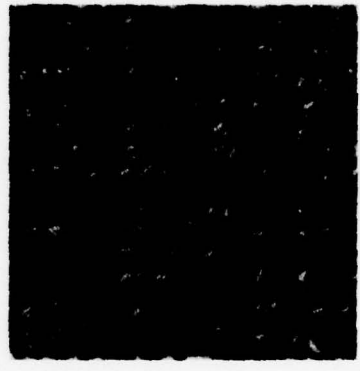

Carpet F-1 Avocado Tweed

OPTION TWO



Paint A 33538
Paint B 30160
Paint C 31136
Paint D 37769



Upholstery Naugahyde DC-10



Round Tables Formica 845-64



Rectangular Tables Formica 830-64



Carpet F-1 Red Tweed

OPTION ONE

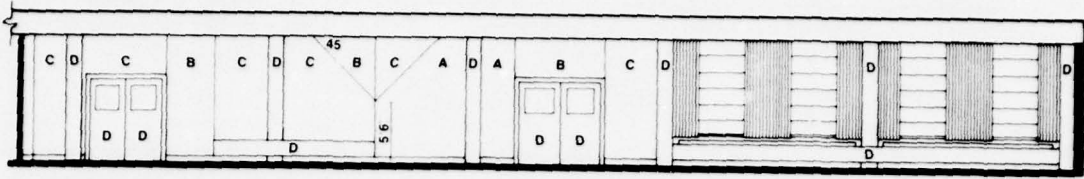

ELEVATION A

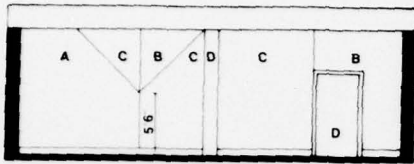

ELEVATION B

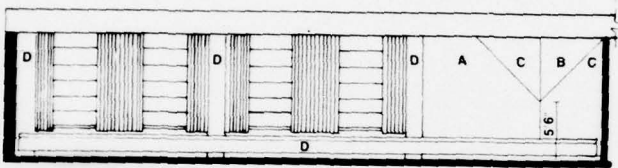

ELEVATION C

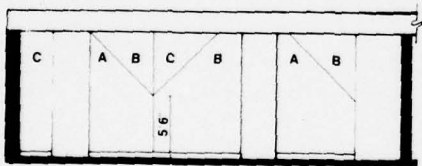

ELEVATION D

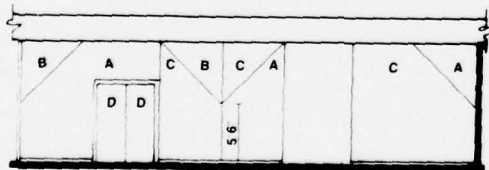

ELEVATION E

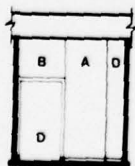

ELEVATION F

**"PATTERNS" geometric forms
INTERIOR ELEVATIONS
BUILDING TYPE 64**

Letters and numbers refer to paint or wall fabric colors as further identified in the ITEM INDEX

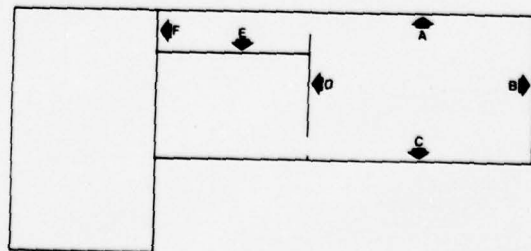

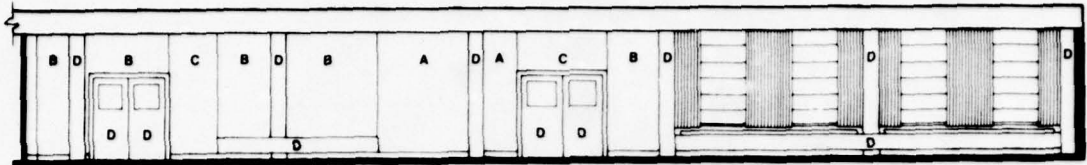

ELEVATION A

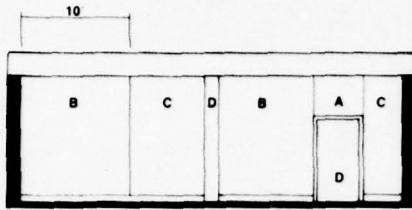

ELEVATION B

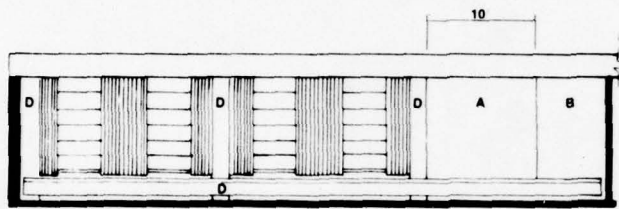

ELEVATION C

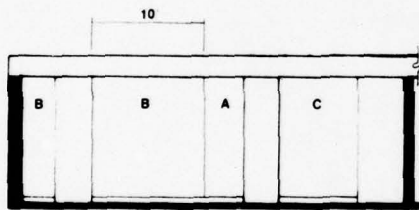

ELEVATION D

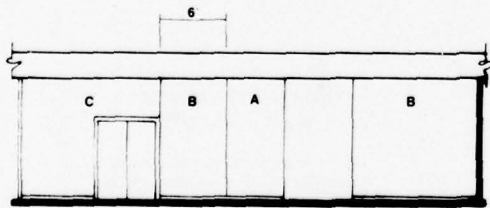

ELEVATION E

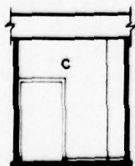

ELEVATION F

**"PATTERNS" stripes
INTERIOR ELEVATIONS
BUILDING TYPE 64**

Letters and numbers refer to paint or wall fabric colors as further identified in the ITEM INDEX

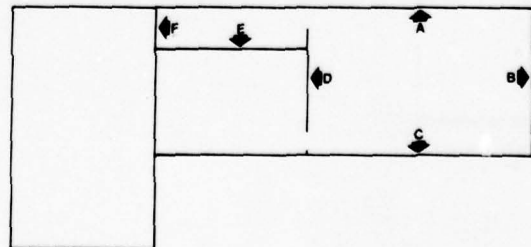

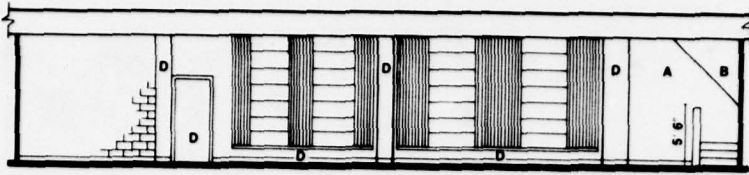

ELEVATION A

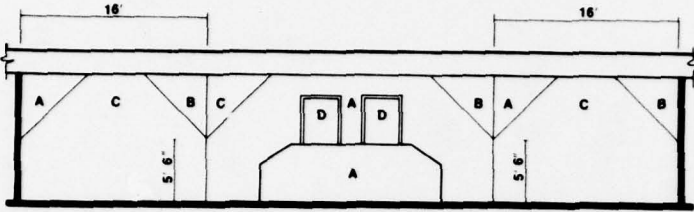

ELEVATION B

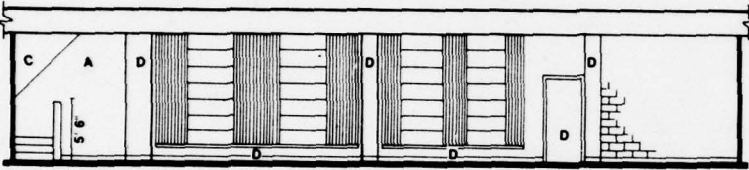

ELEVATION C

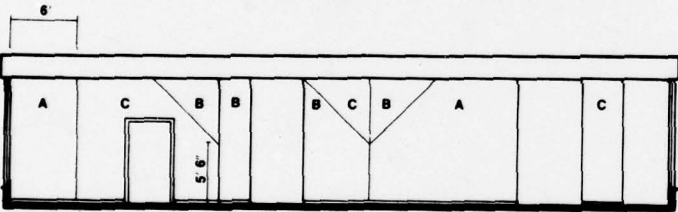

ELEVATION D

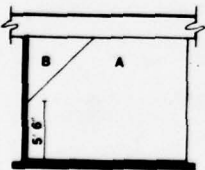

ELEVATION E

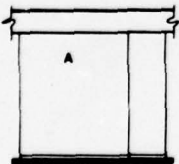

ELEVATION F

**"PATTERNS" geometric forms
INTERIOR ELEVATIONS
BUILDING TYPE 121**

Letters and numbers refer to paint or
wall fabric colors as further identified
in the ITEM INDEX

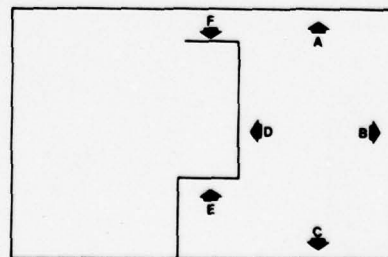

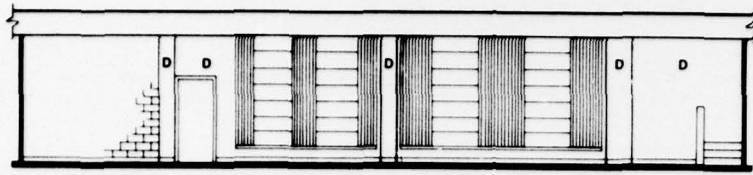

ELEVATION A

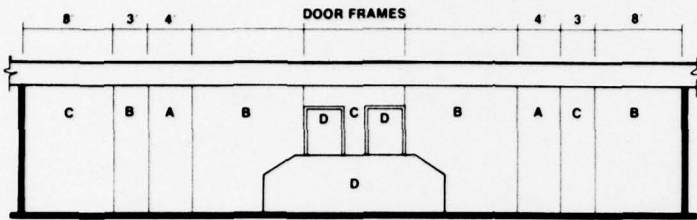

ELEVATION B

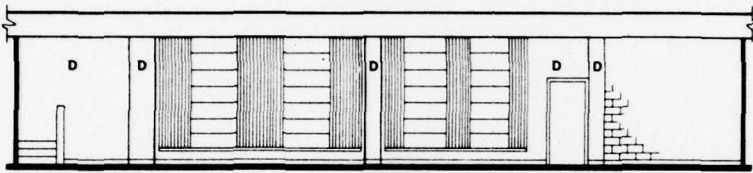

ELEVATION C

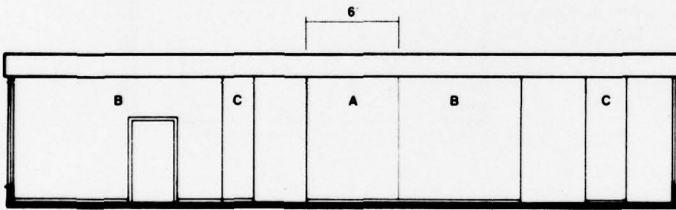

ELEVATION D

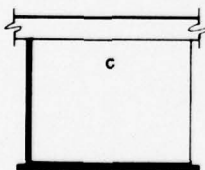

ELEVATION E

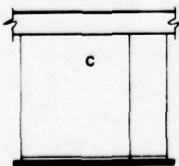

ELEVATION F

**"PATTERNS stripes
INTERIOR ELEVATIONS
BUILDING TYPE 121**

Letters and numbers refer to paint or wall fabric colors as further identified in the ITEM INDEX.

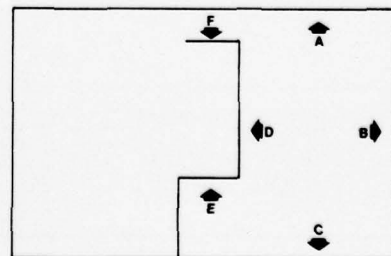

"PATTERNS"

ITEMS LIST

ITEM	CODE NUMBERS		ITEM INDEX	REMARKS
	RECOMMENDED	ALTERNATIVES	PAGE NUMBER	
CHAIR	C-1 and C-2	C-3,C-8,C-9	4-4	
TABLE, 36" x 48"	T-2b	T-1b	4-8	
TABLE, 24" x 36"	T-2a	T-1a	4-8	
TABLE, 54" dia.	T-2c	T-1c	4-8	
BOOTH, SINGLE IS.	B-1s	B-2s	4-9	
BOOTH, DOUBLE IS.	B-1d	B-2d	4-9	
BOOTH, WALL STG	B-1w	B-2w	4-9	
CARPET	F-1	F-2	4-17	See color scheme
QUARRY TILE	F-6		4-17	
VINYL ASBESTOS TILE	F-5		4-17	
BASE	(as required)			
PAINT	W-1		4-20	See color scheme
VINYL FABRIC	(none)			
PARTITIONS	P-1,P-2	P-3	4-24	
WINDOW DRAPERY	D-4	D-2,D-3	4-24	See color scheme
LIGHT FIXTURE	L-3	L-7 if fluorescent	4-26	
MENU BOARD	ME-4		4-40	
TRAY RACK	ME-1		4-38	
SIGNATURE CNT.	ME-2		4-39	
SIGNATURE CNT. STOOL	ME-3		4-39	
SIGN, SIZE A	(as required)		4-41	
SIGN, SIZE B	(as required)		4-41	
BANNERS	DA-1	local choice	4-31	
PAINTINGS	DA-2	local choice	4-31	
MUSIC SYSTEM	(existing on Base)	SS-1	4-36	

CONTEMPORARY

The "Contemporary" design package is similar in style to the "Patterns" scheme; however, the "Contemporary" scheme uses vinyl wall covering instead of painted walls. The predominant pin stripe wall covering produces a "light" atmosphere and has its color repeated in the accent walls, booths, and carpeting. The simplicity of the chairs and booths complements this "light" atmosphere. This scheme is also flexible because a wide choice of appropriate wall decorations, ranging from a "modern" look to a traditional motif, is available.

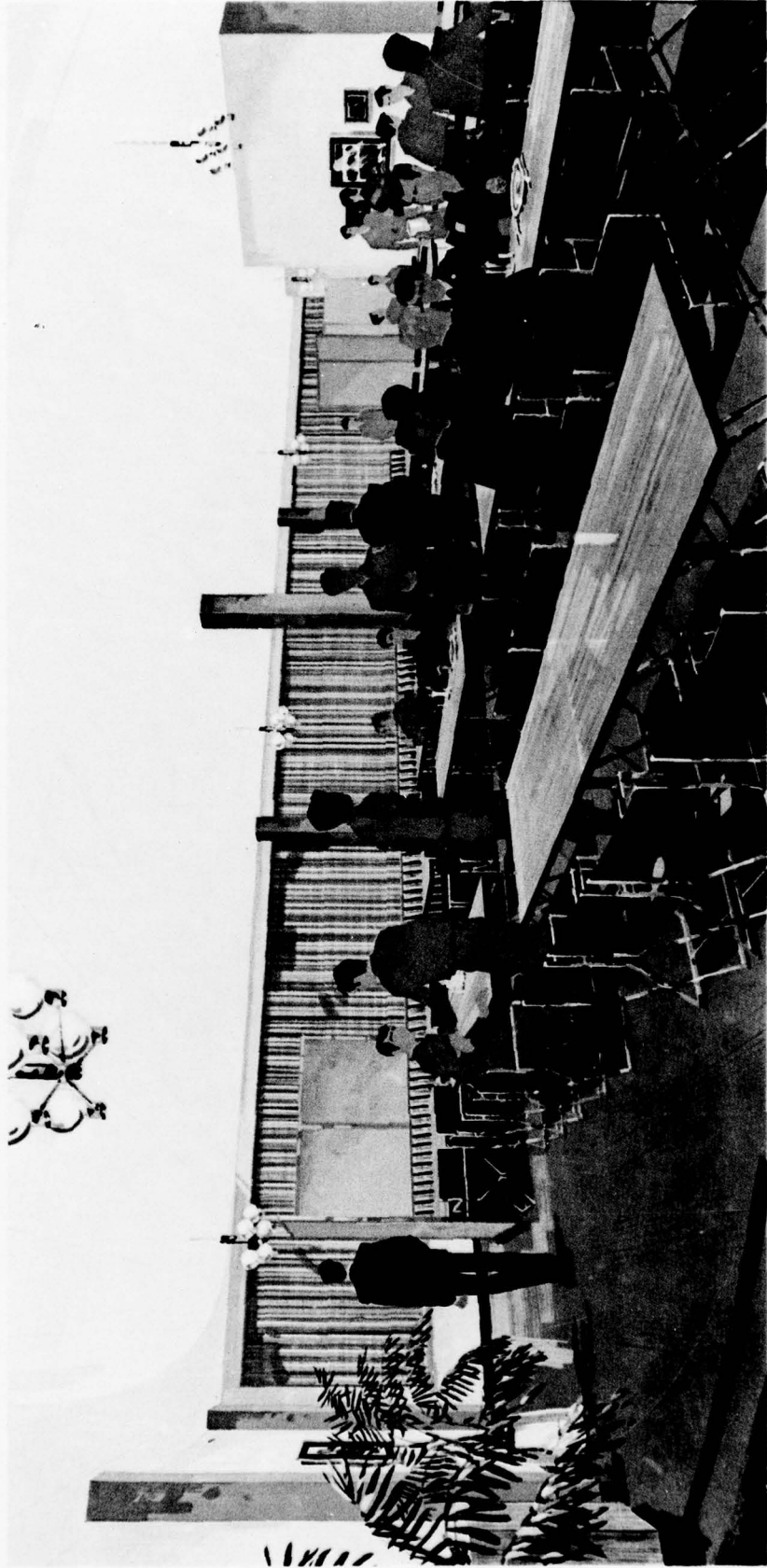

**"CONTEMPORARY"
BUILDING TYPE 106**

COLOR OPTION ONE

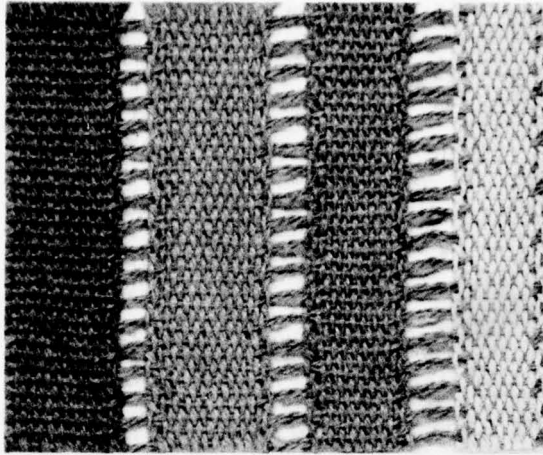

Drapery D-4

Gold Melon



Wall Fabric A

W-4



Paint C
30266



Round Tables
Formica 869-64



Rectangular Tables
Formica 417-64

Upholstery
Naughayde HG-78



Wall Fabric B

W-5

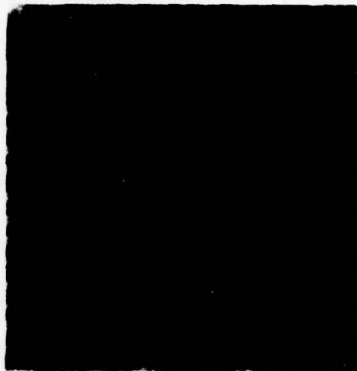

Carpet F-1

Neptune Tweed

OPTION
TWO

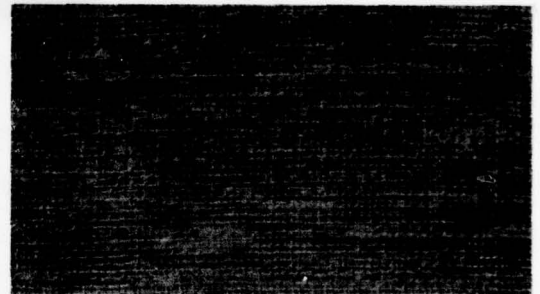

Wall Fabric B

W-5



Carpet F-1

Marigold Tweed

OPTION
ONE

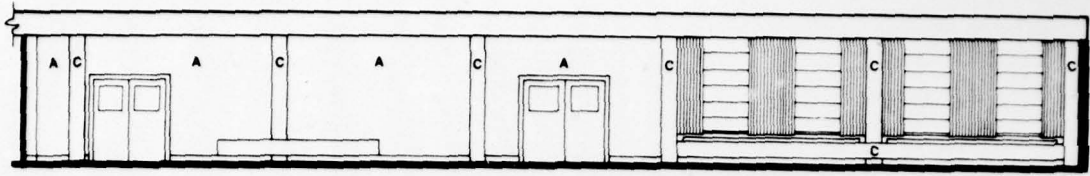

ELEVATION A

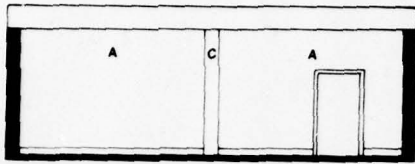

ELEVATION B

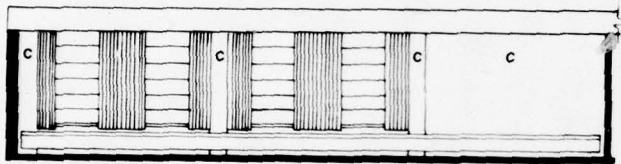

ELEVATION C

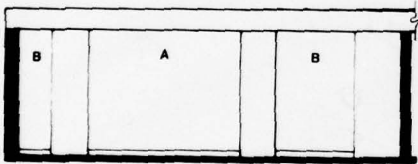

ELEVATION D

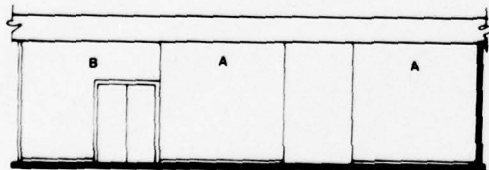

ELEVATION E

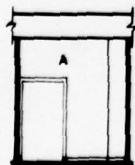

ELEVATION F

**"CONTEMPORARY"
INTERIOR ELEVATIONS
BUILDING TYPE 64**

Letters and numbers refer to paint or wall fabric colors as further identified in the ITEM INDEX.

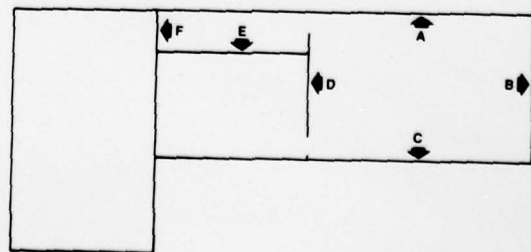

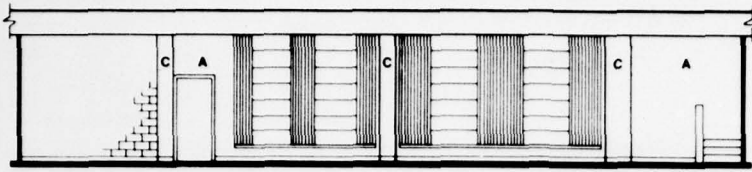

ELEVATION A

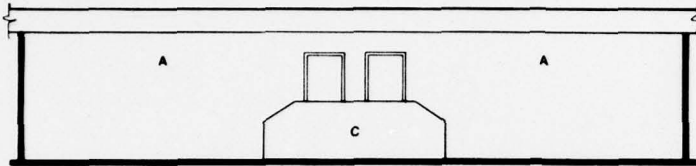

ELEVATION B

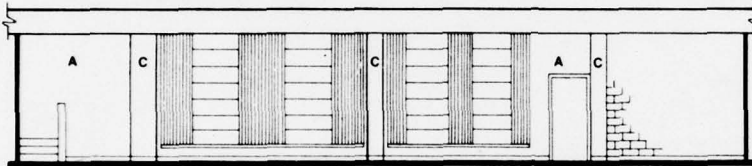

ELEVATION C

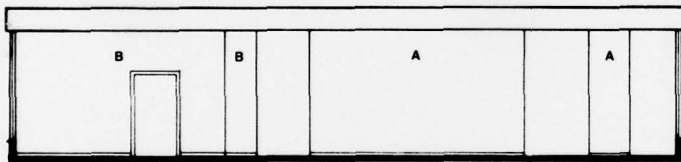

ELEVATION D

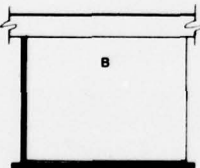

ELEVATION E

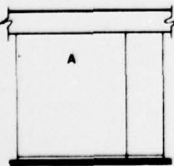

ELEVATION F

**"CONTEMPORARY"
INTERIOR ELEVATIONS
BUILDING TYPE 121**

Letters and numbers refer to paint or wall fabric colors as further identified in the ITEM INDEX.

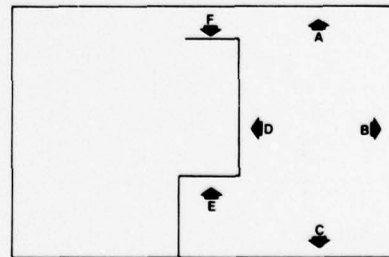

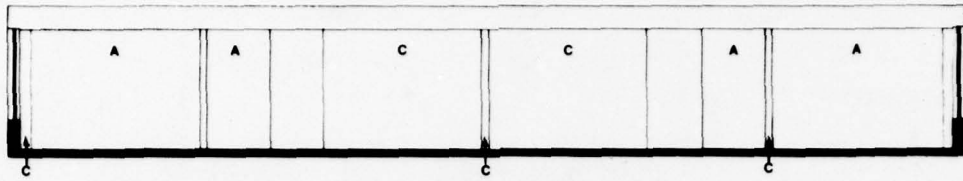

ELEVATION A

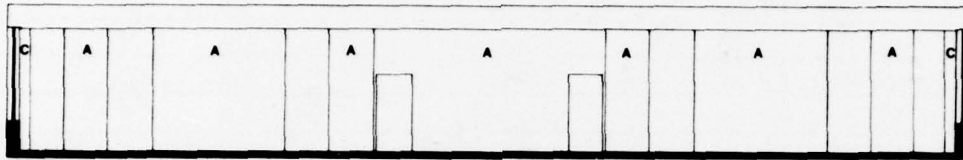

ELEVATION B

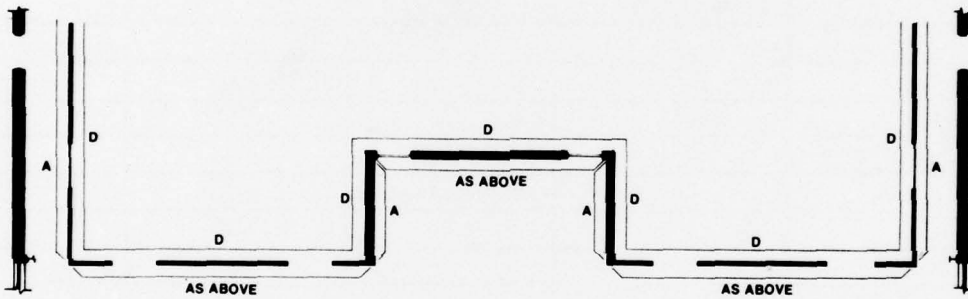

Plan view of ELEVATION B

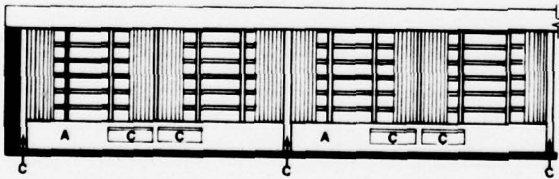

ELEVATION C

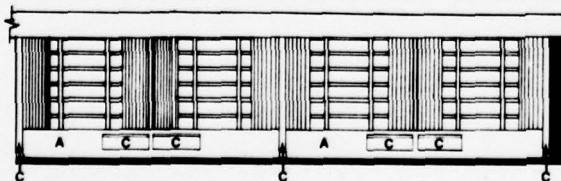

ELEVATION D

**"CONTEMPORARY"
INTERIOR ELEVATIONS
BUILDING TYPE 106**

Letters and numbers refer to paint or wall fabric colors as further identified in the ITEM INDEX

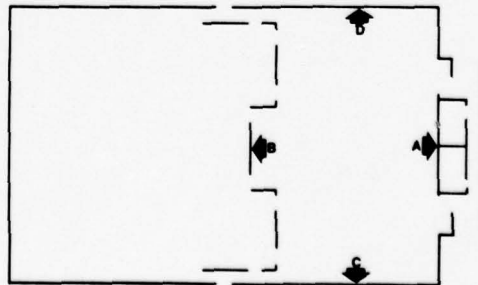

"CONTEMPORARY"

ITEMS LIST

ITEM	CODE NUMBERS		ITEM INDEX	REMARKS
	RECOMMENDED	ALTERNATIVES	PAGE NUMBER	
CHAIR	C-3	C-8,C-9	4-4	
TABLE, 36" x 48"	T-2b	T-1b	4-8	
TABLE, 24" x 36"	T-2a	T-1a	4-8	
TABLE, 54" dia.	T-2c	T-1c	4-8	
BOOTH, SINGLE IS.	B-2s	B-1s	4-9	
BOOTH, DOUBLE IS.	B-2d	B-1d	4-9	
BOOTH, WALL STG	B-2w	B-1w	4-9	
CARPET	F-1	F-2	4-17	See color scheme
QUARRY TILE	F-6		4-17	
VINYL ASBESTOS TILE	F-5		4-17	
BASE	(as required)			
PAINT	W-1		4-20	See color scheme
VINYL FABRIC	W-4,W-5,W-6		4-20	
PARTITIONS	P-1,P-2	P-3	4-24	
WINDOW DRAPERY	D-4		4-24	
LIGHT FIXTURE	L-3	L-7 if fluorescent	4-26	
MENU BOARD	ME-4		4-40	
TRAY RACK	ME-1		4-38	
SIGNATURE CNT.	ME-2		4-39	
SIGNATURE CNT. STOOL	ME-3		4-39	
SIGN, SIZE A	(as required)		4-41	
SIGN, SIZE B	(as required)		4-41	
BANNERS	DA-1	local choice	4-31	
PAINTINGS	DA-2	DA-10 or DA-11	4-31	local choice
MUSIC SYSTEM	(existing on Base)	SS-1	4-36	

SKI LODGE

The "Ski Lodge" style uses wooden furniture with highly textured, rustic wall coverings. Unfinished wood, combined with warm, harmonious colors, usually produces a feeling of nature. The use of plants also enhances this "nature look." The textured wall coverings should be used sparingly for special emphasis and to prevent their strong patterns from dominating the space. Appropriate wall hangings of outdoor scenes and/or copper wall sculptures augment the coloring and textures within this design scheme.



**"SKI LODGE"
BUILDING TYPE 121**

COLOR OPTION TWO

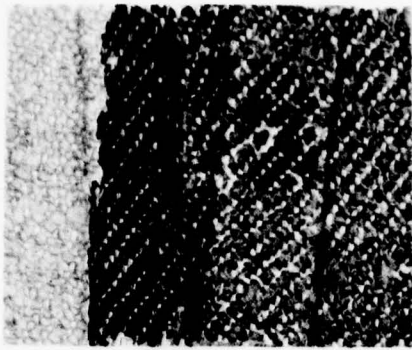

Drapery D-3

Green Gold

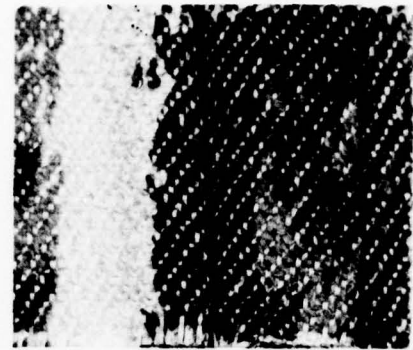

Drapery D-3

Blue

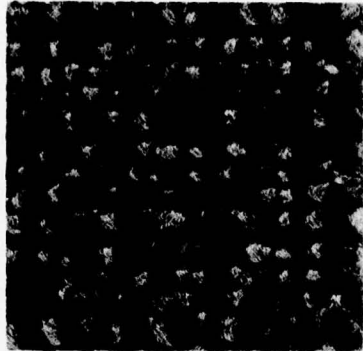

Carpet F-1 Horizon Copper Tweed

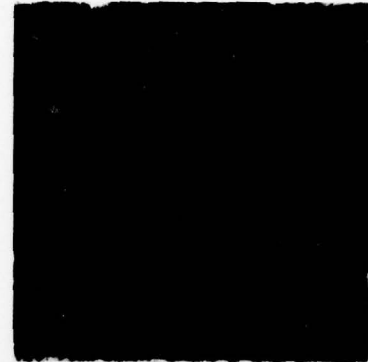

Carpet F-1

Neptune Tweed

Upholstery
Naugahyde HG-56



OPTION ONE



Paint C 32169



Round Tables Formica
841-64

Upholstery
Naugahyde HG-70



OPTION TWO



Paint C 34138



Round Tables Formica
851-64

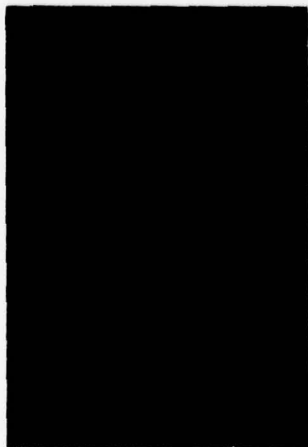

Wall Fabric A

W-3

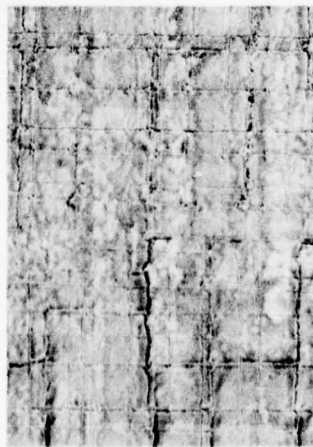

Wall Fabric B

W-2

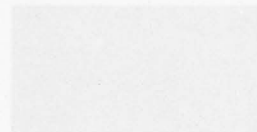

Paint D
37769
(ceiling, if
required)

Rectangular Tables
Formica 417-64



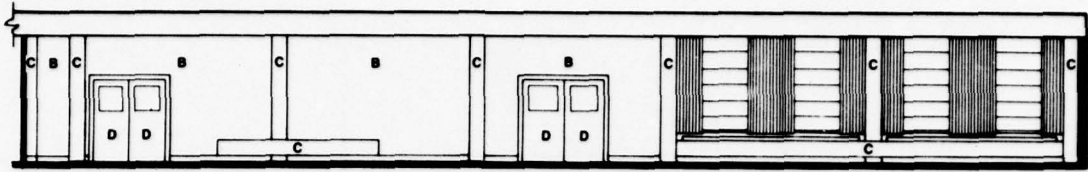

ELEVATION A

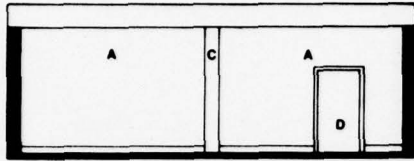

ELEVATION B

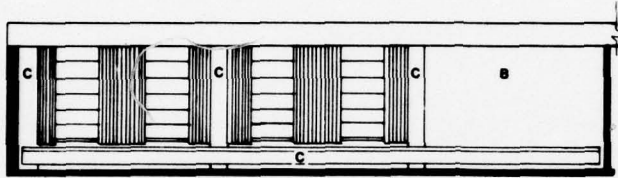

ELEVATION C

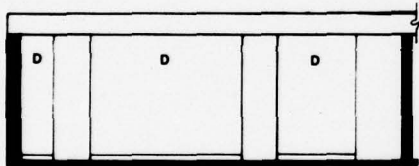

ELEVATION D

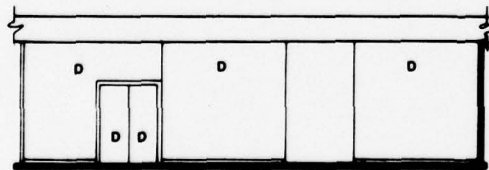

ELEVATION E

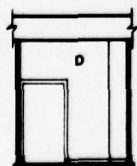

ELEVATION F

**"SKI LODGE"
INTERIOR ELEVATIONS
BUILDING TYPE 64**

Letters and numbers refer to paint or wall fabric colors as further identified in the ITEM INDEX.

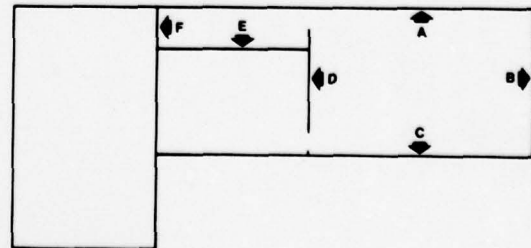

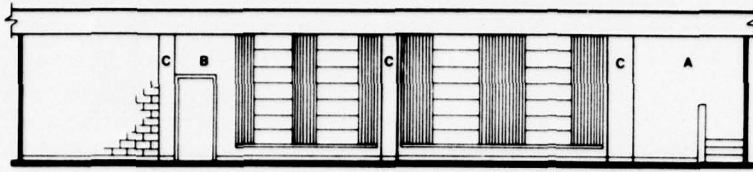

ELEVATION A

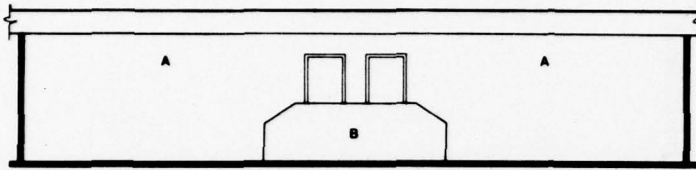

ELEVATION B

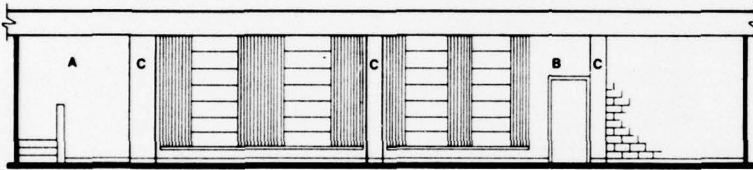

ELEVATION C

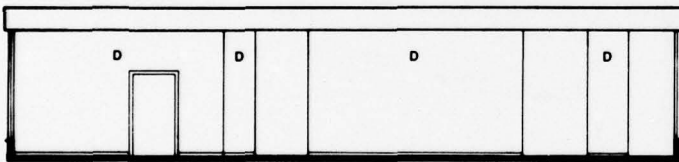

ELEVATION D

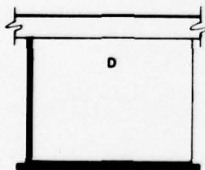

ELEVATION E

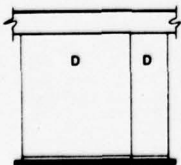

ELEVATION F

**"SKI LODGE"
INTERIOR ELEVATIONS
BUILDING TYPE 121**

Letters and numbers refer to paint or wall fabric colors as further identified in the ITEM INDEX.

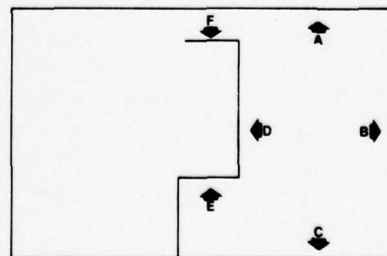

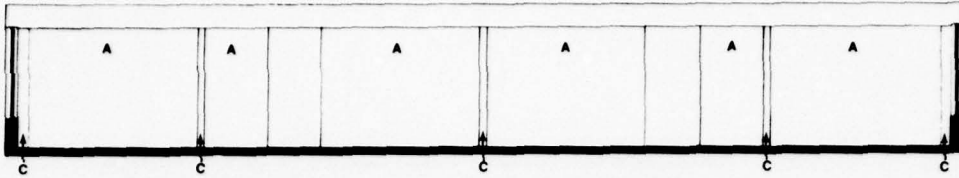

ELEVATION A

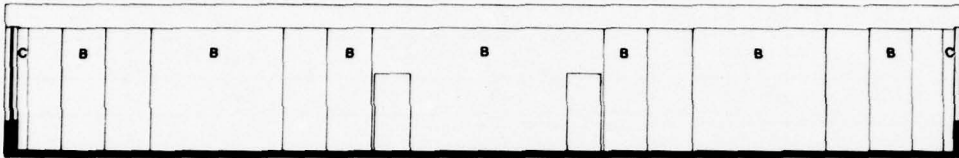

ELEVATION B

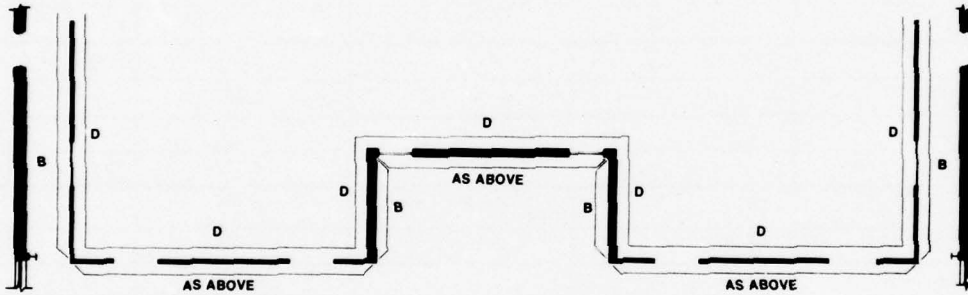

Plan view of ELEVATION B

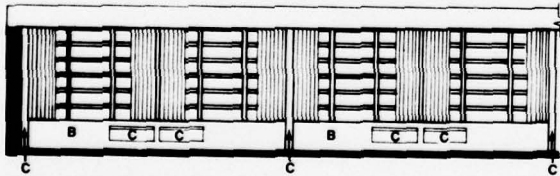

ELEVATION C



ELEVATION D

**"SKI LODGE"
INTERIOR ELEVATIONS
BUILDING TYPE 106**

Letters and numbers refer to paint or wall fabric colors as further identified in the ITEM INDEX.

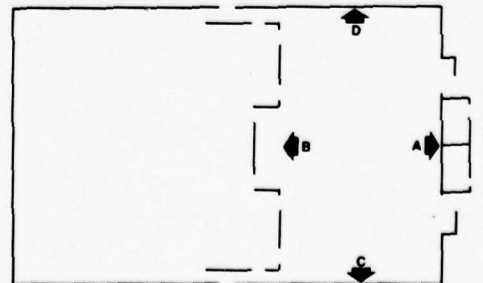

"SKI-LODGE"

ITEMS LIST

ITEM	CODE NUMBERS		ITEM INDEX	REMARKS
	RECOMMENDED	ALTERNATIVES	PAGE NUMBER	
CHAIR	C-1,C-2	C-4,C-5	4-4	
TABLE, 36" x 48"	T-2b	T-1b	4-8	
TABLE, 24" x 36"	T-2a	T-1a	4-8	
TABLE, 54" dia.	T-2c	T-1c	4-8	
BOOTH, SINGLE IS.	B-1s	B-2s	4-9	
BOOTH, DOUBLE IS.	B-1d	B-2d	4-9	
BOOTH, WALL STG	B-1w	B-2w	4-9	
CARPET	F-1	F-2	4-17	See color scheme
QUARRY TILE	F-6		4-17	
VINYL ASBESTOS TILE	F-5		4-17	
BASE	(as required)			
PAINT	W-1		4-20	See color scheme
VINYL FABRIC	W-2,W-3		4-20	
PARTITIONS	P-1,P-2	P-3	4-24	
WINDOW DRAPERY	D-3		4-24	See color scheme
LIGHT FIXTURE	L-6	L-7 if fluorescent	4-26	
MENU BOARD	ME-4		4-40	
TRAY RACK	ME-1		4-38	
SIGNATURE CNT.	ME-2		4-39	
SIGNATURE CNT. STOOL	ME-3		4-39	
SIGN, SIZE A	(as required)		4-41	
SIGN, SIZE B	(as required)		4-41	
SCULPTURE	DA-5	local choice	4-32	
PAINTINGS	DA-3,DA-4	local choice	4-32	
MUSIC SYSTEM	(existing on Base)	SS-1	4-36	

PUB

The "Pub" design package uses dark colors, distressed wood, and rough textures, with the accent color in the carpet. The three wall coverings illustrated are: (1) rough textured, neutral-colored vinyl, (2) dark brown cork, and (3) carpet. While funds may restrict the use of the cork and carpet, the acoustic properties and aesthetic qualities of these materials are quite desirable for this scheme. Wall hangings—i.e. carvings, armament plaques, and traditional hunting scenes—will give special character to a "Pub" design. The Decorative Accessories section includes wall painting examples that can be used to give this design solution either a "western" or a "sports" theme. However, other themes can easily be carried out by choosing other decorative accessories to suit a local group.

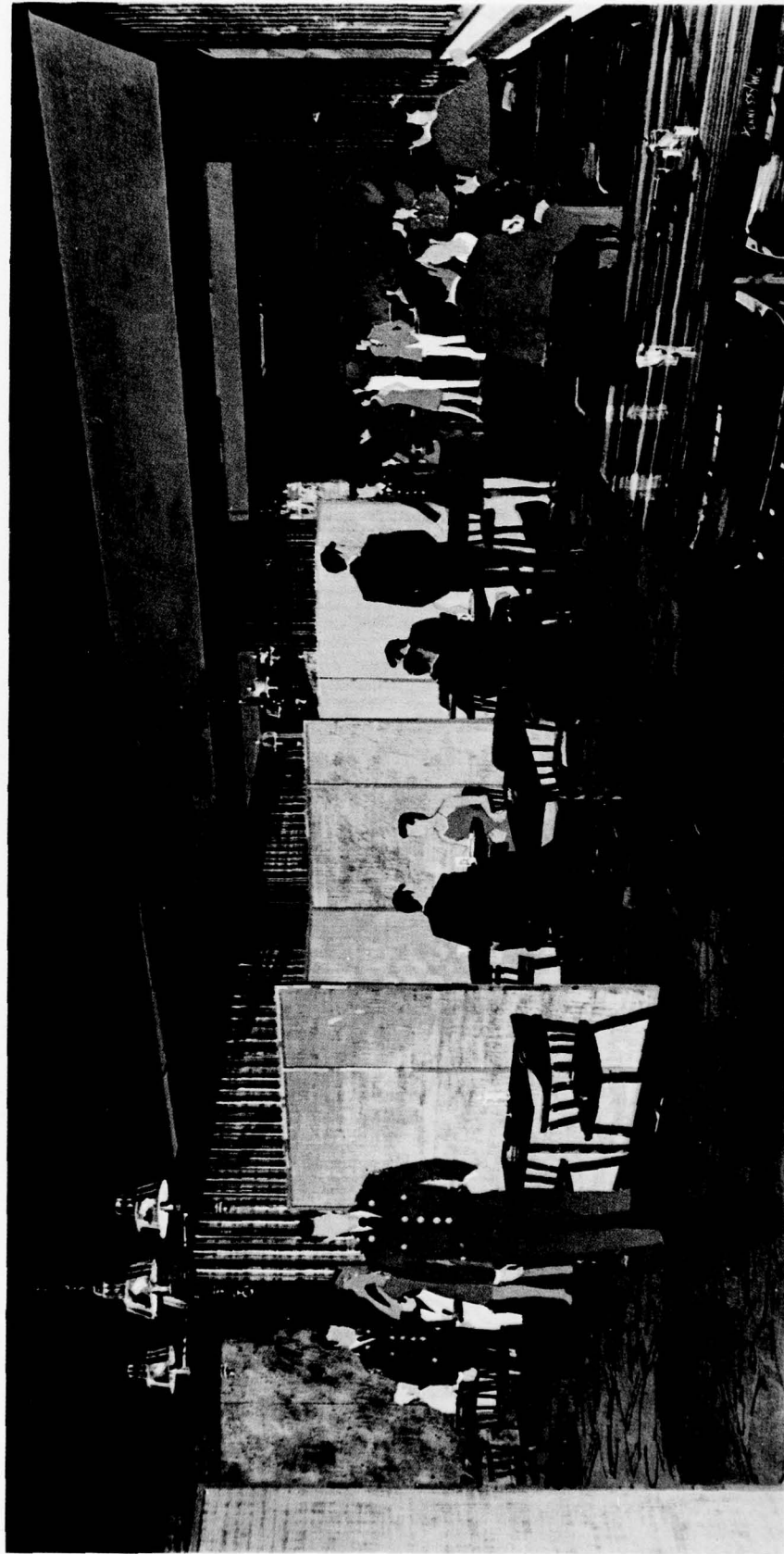

**"PUB"
BUILDING TYPE 64**

COLOR OPTION ONE

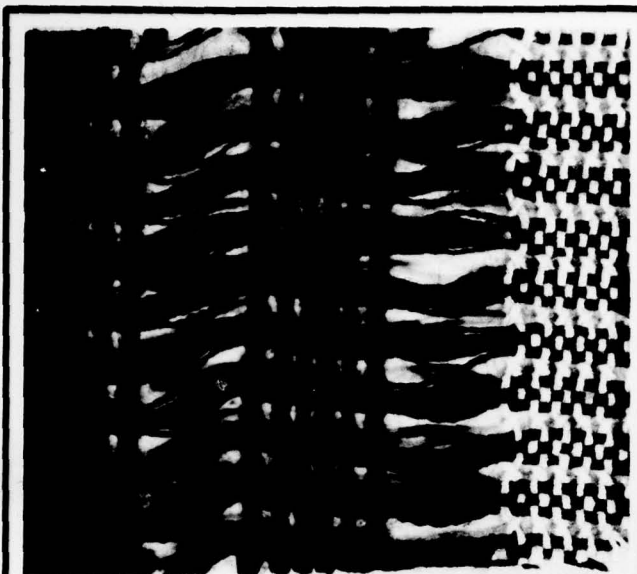

Drapery D-1

Sable

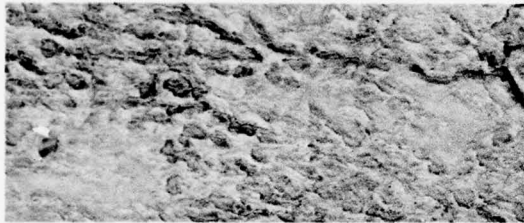

Wall Fabric A

W-9

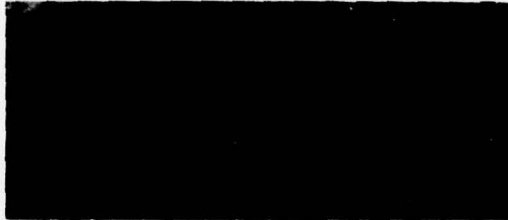

Wall Fabric B

W-10

Paint C
37769



Paint D
30045
(ceiling, if
required)



All Tables
Formica 343-64

Upholstery
(same as option
two)

Carpet F-3
Red

OPTION
ONE

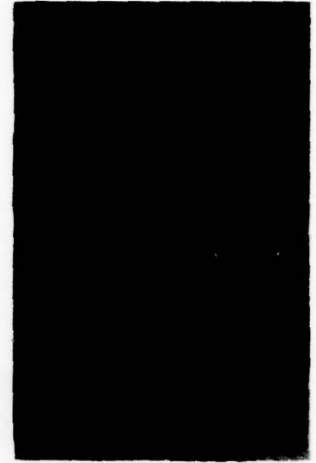

Upholstery
Naugahyde HG-76

Carpet F-1
Red Tweed

OPTION
TWO



OPTION
THREE

Carpet F-1
Mahogany
Tweed



Upholstery
Naugahyde DC-10

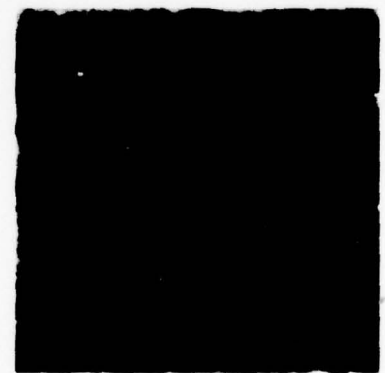

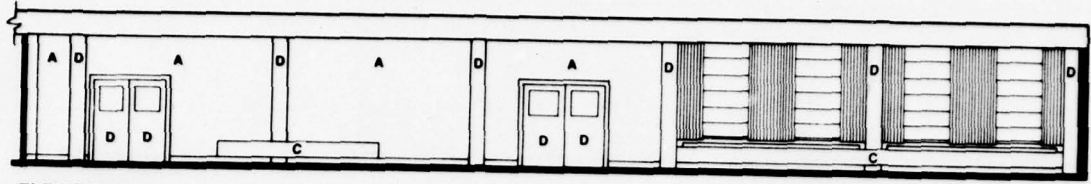

ELEVATION A

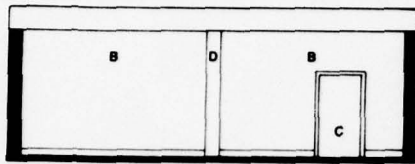

ELEVATION B

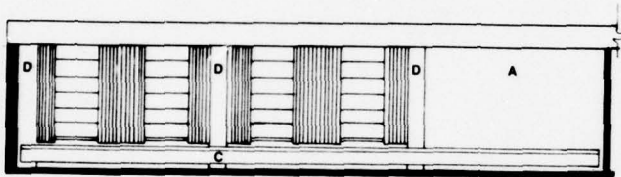

ELEVATION C

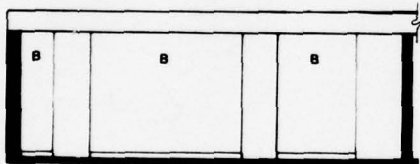

ELEVATION D

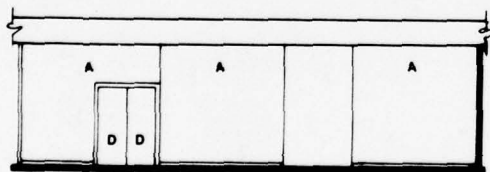

ELEVATION E

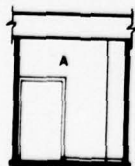

ELEVATION F

"PUB"
INTERIOR ELEVATIONS
BUILDING TYPE 64

Letters and numbers refer to paint or wall fabric colors as further identified in the ITEM INDEX.

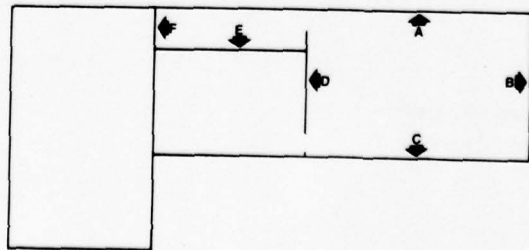

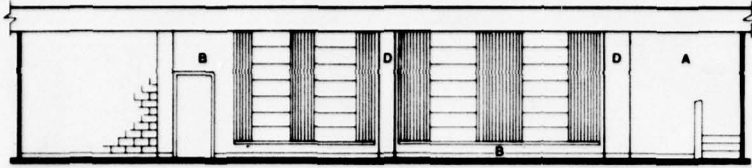

ELEVATION A

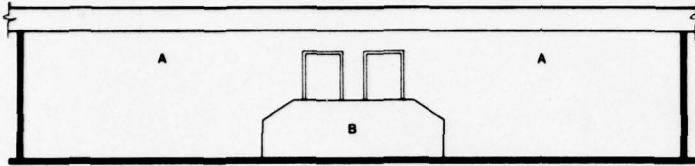

ELEVATION B

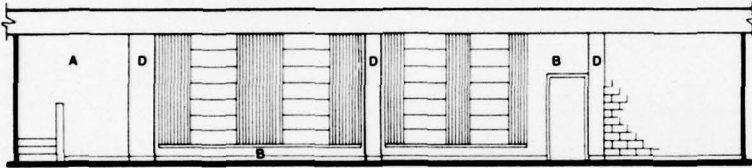

ELEVATION C

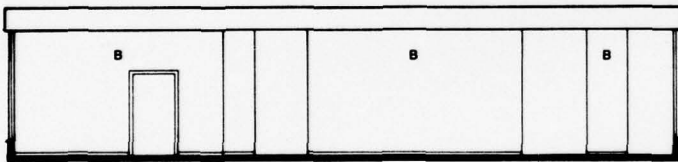

ELEVATION D

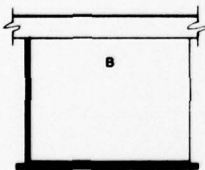

ELEVATION E

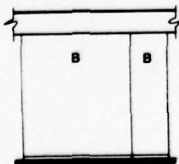

ELEVATION F

**"PUB"
INTERIOR ELEVATIONS
BUILDING TYPE 121**

Letters and numbers refer to paint or wall fabric colors as further identified in the ITEM INDEX.

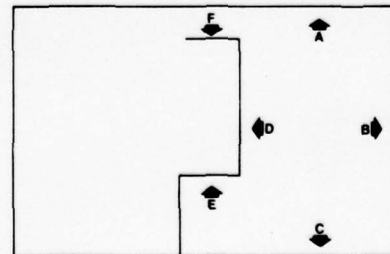

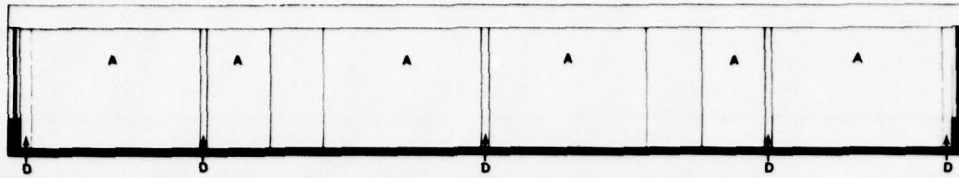

ELEVATION A

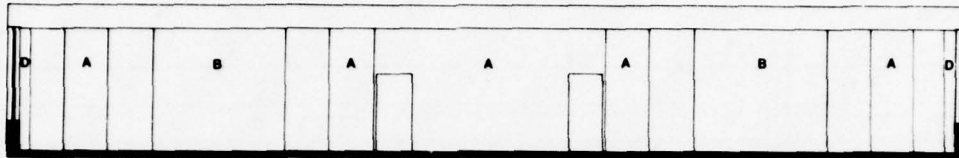

ELEVATION B

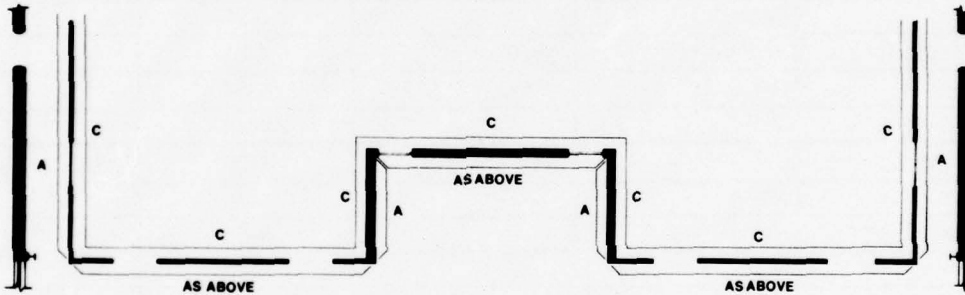

Plan view of ELEVATION B

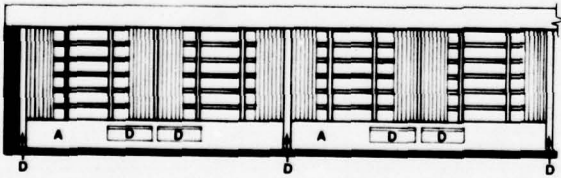

ELEVATION C

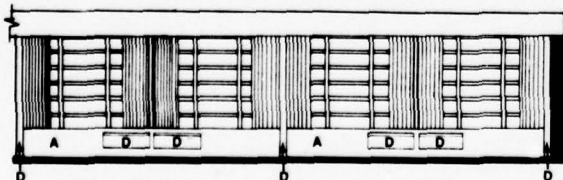

ELEVATION D

**"PUB"
INTERIOR ELEVATIONS
BUILDING TYPE 106**

Letters and numbers refer to paint or wall fabric colors as further identified in the ITEM INDEX.

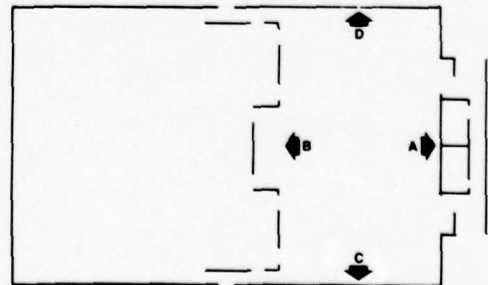

ITEM	CODE NUMBERS		ITEM INDEX	REMARKS
	RECOMMENDED	ALTERNATIVES	PAGE NUMBER	
CHAIR	C-4	C-5	4-4	
TABLE, 36" x 48"	T-3b	T-4b	4-8	
TABLE, 24" x 36"	T-3a	T-4a	4-8	
TABLE, 54" dia.	T-3c	T-4c	4-8	
BOOTH, SINGLE IS.	B-3s		4-9	
BOOTH, DOUBLE IS.	B-3d		4-9	
BOOTH, WALL STG	B-5w		4-9	
CARPET	F-3		4-17	See color scheme
QUARRY TILE	F-6		4-17	
VINYL ASBESTOS TILE	F-5		4-17	
BASE	(as required)			
PAINT	W-1		4-20	
VINYL FABRIC	W-9,W-10	W-9 only	4-21	
PARTITIONS	P-1,P-2	P-3	4-24	
WINDOW DRAPERY	D-1		4-24	
LIGHT FIXTURE	L-4	L-2,L-1	4-26	L-7 if fluorescent
MENU BOARD	ME-4		4-40	
TRAY RACK	ME-1		4-38	
SIGNATURE CNT.	ME-2		4-39	
SIGNATURE CNT. STOOL	ME-3		4-39	
SIGN, SIZE A	(as required)		4-41	
SIGN, SIZE B	(as required)		4-41	
BANNERS				local choice
PAINTINGS	DA-6 or DA-8	DA-7 or DA-9	4-33	local choice
MUSIC SYSTEM	(existing at Base)	SS-1	4-36	

EUROPEAN

Dark colors and ornate wooden furniture are used here to create a "European" look. Since it is more formal than the other design schemes, the "European" can provide an alternative environment when there is a choice of dining facilities. The only option is the bright accent of the upholstery color amidst the dark wood tones. The carpet pattern complements the furniture details. Several paintings in the Decorative Accessories section provide color contrast to the walls and are compatible with the European motif.

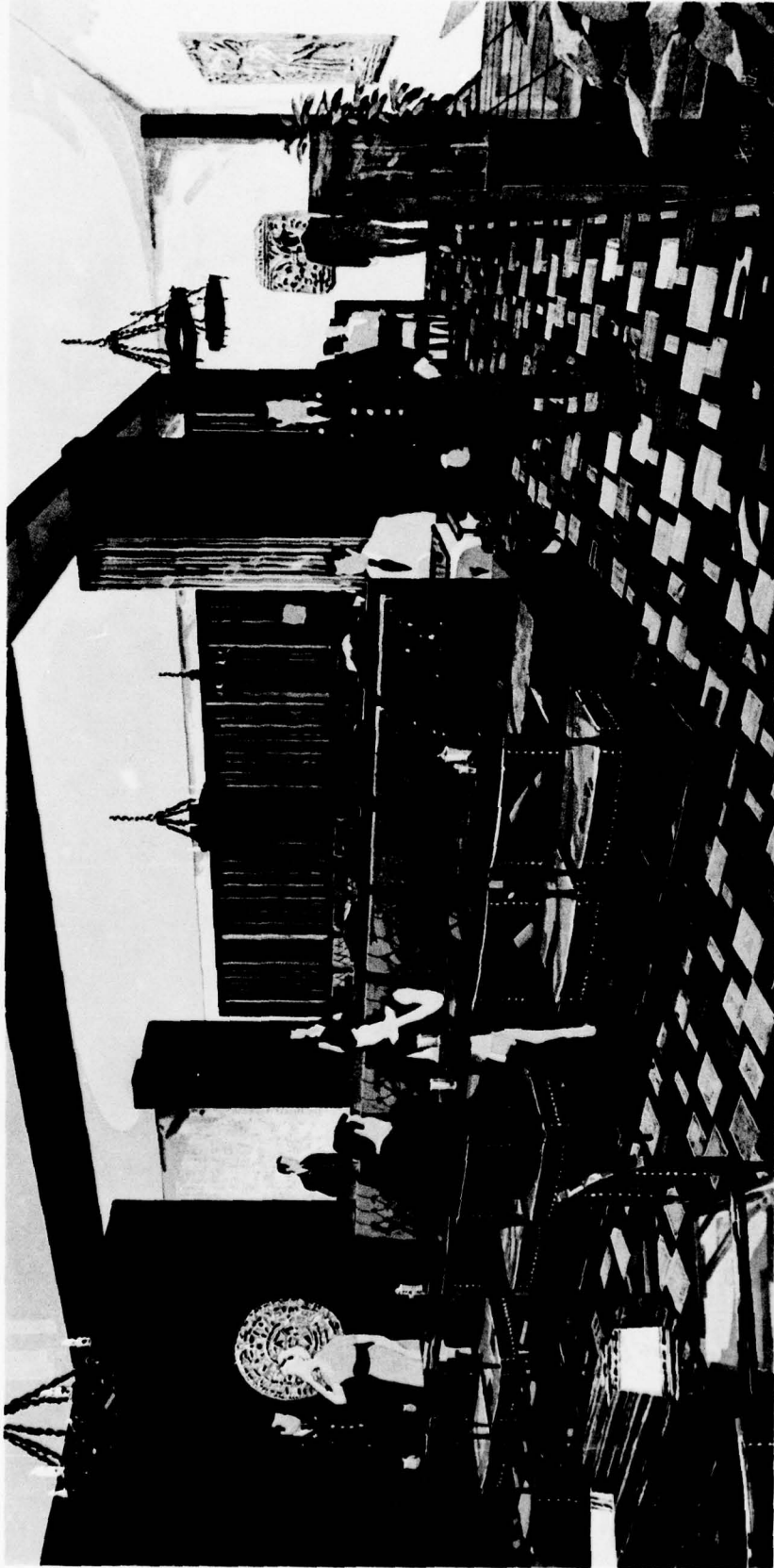

"EUROPEAN"
BUILDING TYPE 121

COLOR OPTION ONE



Carpet F-4

Natural

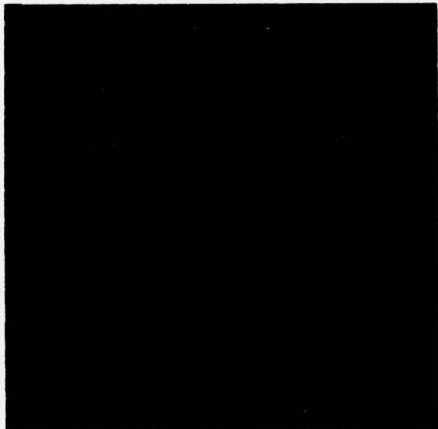

Wall Fabric A

W-8

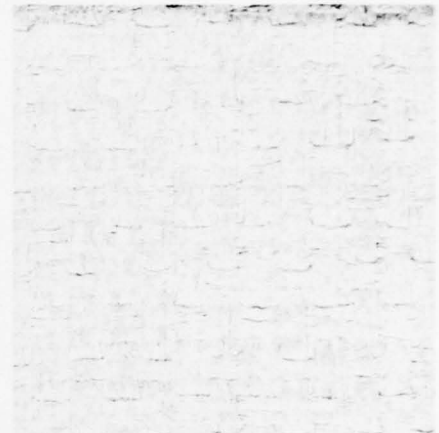

Wall Fabric B

W-7

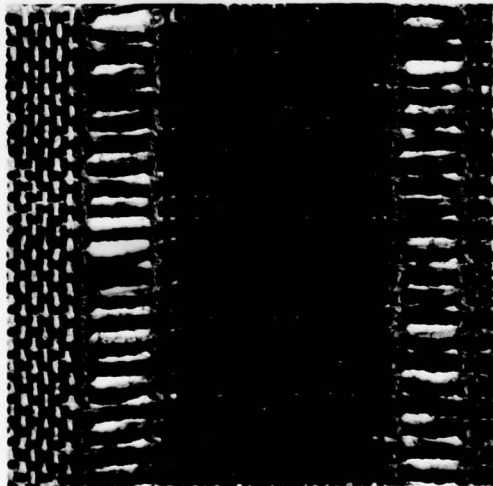

Drapery D-2

Charcoal



Paint C
30045



Paint D
33448
(ceiling if required)



Round Tables
Formica 795-81



Rectangular Tables
Formica 830-64

Upholstery
Naugahyde HG-63

OPTION ONE

Upholstery
Naugahyde HG-44

OPTION TWO

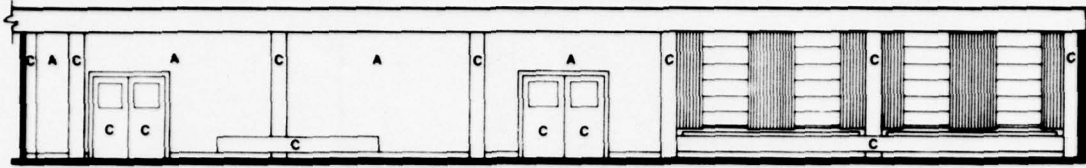

ELEVATION A

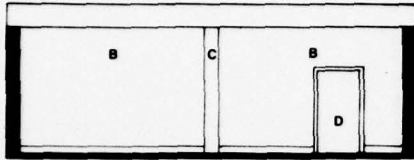

ELEVATION B

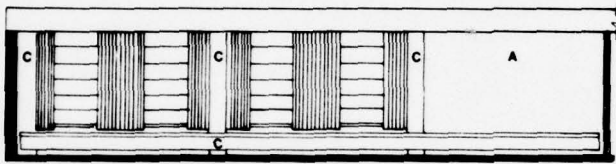

ELEVATION C

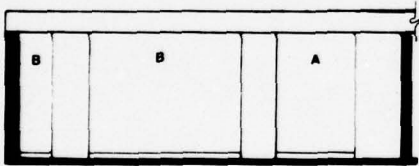

ELEVATION D

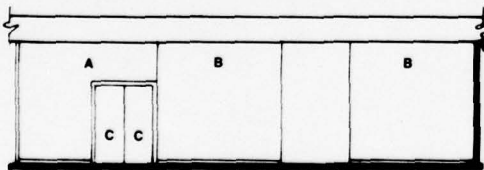

ELEVATION E

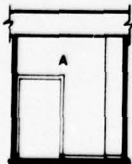

ELEVATION F

**"EUROPEAN"
INTERIOR ELEVATIONS
BUILDING TYPE 64**

Letters and numbers refer to paint or wall fabric colors as further identified in the ITEM INDEX.

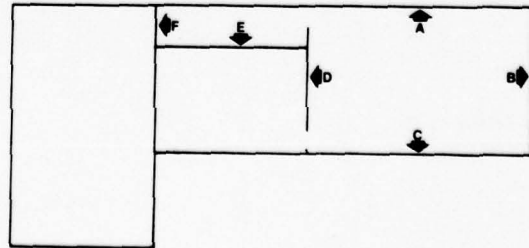

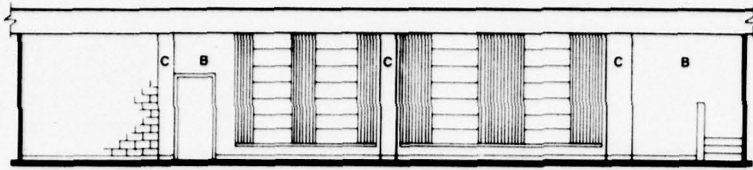

ELEVATION A

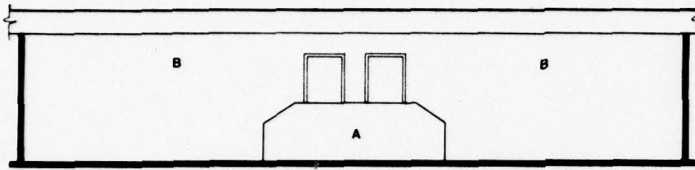

ELEVATION B

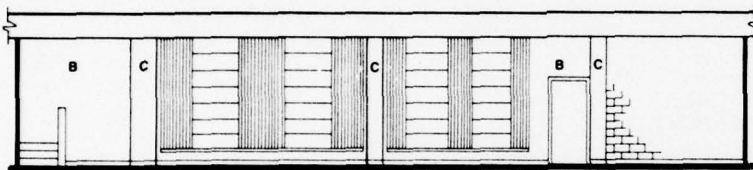

ELEVATION C

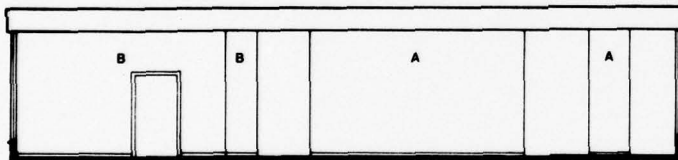

ELEVATION D

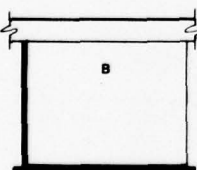

ELEVATION E

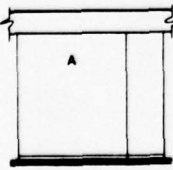

ELEVATION F

**"EUROPEAN"
INTERIOR ELEVATIONS
BUILDING TYPE 121**

Letters and numbers refer to paint or wall fabric colors as further identified in the ITEM INDEX.

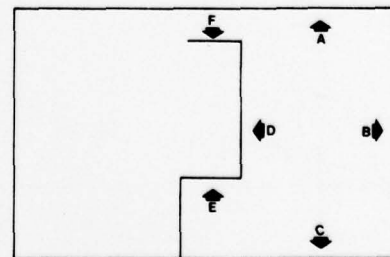

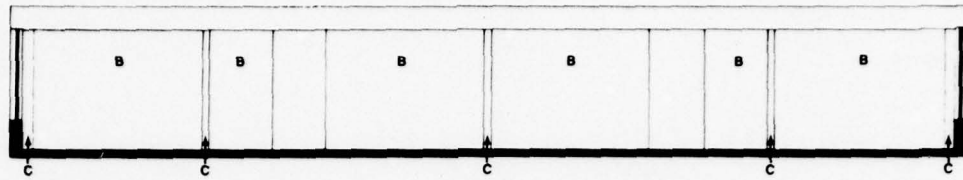

ELEVATION A

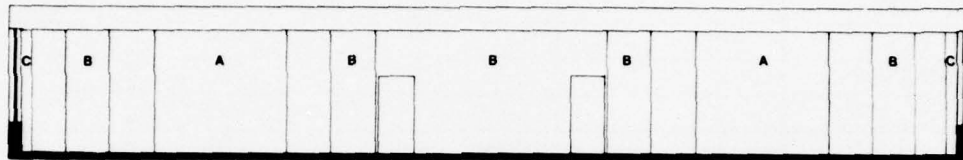

ELEVATION B

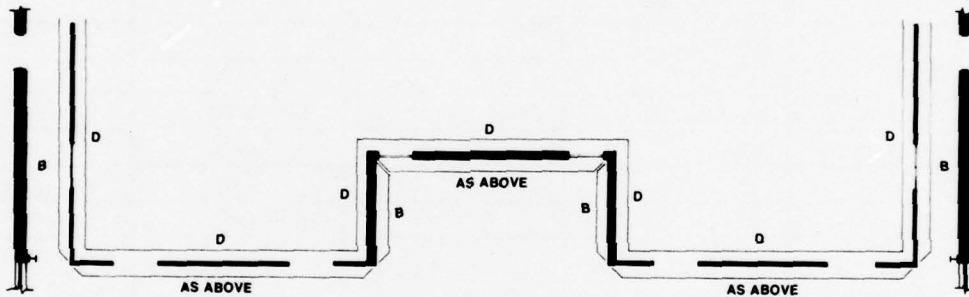

Plan view of ELEVATION B

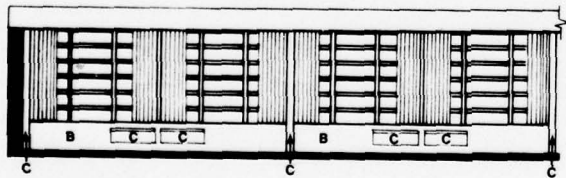

ELEVATION C

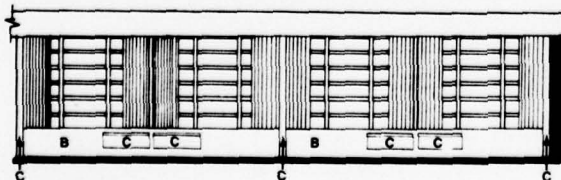

ELEVATION D

**"EUROPEAN"
INTERIOR ELEVATIONS
BUILDING TYPE 106**

Letters and numbers refer to paint or wall fabric colors as further identified in the ITEM INDEX

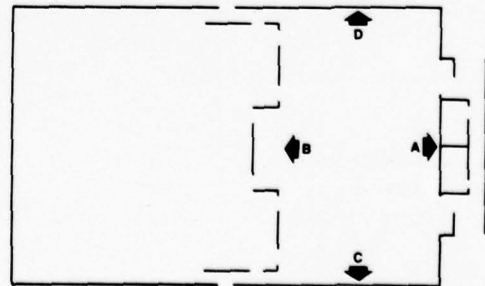

"EUROPEAN"

ITEMS LIST

ITEM	CODE NUMBERS		ITEM INDEX	REMARKS
	RECOMMENDED	ALTERNATIVES	PAGE NUMBER	
CHAIR	C-6	C-7	4-4	
TABLE, 36" x 48"	T-3b		4-8	
TABLE, 24" x 36"	T-3a		4-8	
TABLE, 54" dia.	T-3c		4-8	
BOOTH, SINGLE IS.	B-4s	B-5s	4-9	
BOOTH, DOUBLE IS.	B-4d	B-5d	4-9	
BOOTH, WALL STG	B-4w	B-5w	4-9	
CARPET	F-4		4-17	
QUARRY TILE	F-6		4-17	
VINYL ASBESTOS TILE	F-5		4-17	
BASE	(as required)			
PAINT	W-1		4-20	
VINYL FABRIC	W-7, W-8		4-21	
PARTITIONS	P-1, P-2	P-3	4-24	
WINDOW DRAPERY	D-2		4-24	
LIGHT FIXTURE	L-5	L-2	4-26	L-7 if fluorescent
MENU BOARD	ME-4		4-40	
TRAY RACK	ME-1		4-38	
SIGNATURE CNT.	ME-2		4-39	
SIGNATURE CNT. STOOL	ME-3		4-39	
SIGN, SIZE A	(as required)		4-41	
SIGN, SIZE B	(as required)		4-41	
BANNERS	(none)	travel posters		local choice
PAINTINGS	DA-10	DA-11	4-34	local choice
MUSIC SYSTEM	(existing at Base)	SS-1	4-36	

4 ITEM INDEX

Each layout has a quantitative list of items corresponding to items within this section. This list is clarified on the Listing of Items page of the Design Package section according to the type and color of each item related to a particular package. The code category on the Listing of Items page refers to the code in the Item Index. Note that in addition to the layout and Listing of Items pages for each design package, the Worksheets and Pricing section should be used with the Item Index.

Items for furnishing dining facilities are organized into nine categories:

1. Chairs
2. Tables and booths
3. Floor coverings
4. Wall coverings
5. Partitions and drapery
6. Lighting
7. Decorative accessories
8. Miscellaneous equipment
9. Sound system

Each category includes three sections of information: (1) a general discussion of the item types, (2) photographs of recommended selections, and (3) a description of each item including the representative manufacturers.

CHAIRS

The type of chair used in a dining facility should be specified as "heavy commercial." A wide variety of chair types is available in stock colors and materials (wood finishes and upholsteries). Special colors and materials can be obtained from furniture dealers if large quantities are ordered.

Chairs. The commercial seating industry offers chairs in a wide variety of styles, colors, materials, and costs. Different styles are possible by interchanging the standard parts—i.e., frames, backs, seats, and upholstery.

Frames. Chair frames can be made of wood, steel or aluminum. Wood is pleasing and more stylish; however, more material is needed for a wooden frame, so the chair is heavier, less mobile, and usually more expensive. Metal frames usually have welded joints, are relatively light-weight, and are made from 18-gauge minimum materials. Metal frame construction is more diverse than wood—pedestal (with or without casters) or sled base (preferred for carpets) styles are available; and some types have stacking capabilities. It is recommended that all wooden and metal bases (except pedestal) have cross-bracing to prevent damage due to "lean back."

Seats and Backs. These components are usually constructed in one of two ways: (1) wood (hardwood or plywood) fastened to or an integral part of the frame, or (2) molded, one-piece plastic shells. Both types are available with upholstery. Plastic chair seats and backs are available in polypropylene, acrylonitrile butadiene styrene (ABS), or compressed nylon. Each material has distinct disadvantages: polypropylene is more difficult to clean and melts from burns; ABS is more easily scratched; fiberglass and compressed nylon are more easily stained and have a limited selection of colors. All of the materials except nylon can be extremely lightweight. It is strongly recommended that they be upholstered. Plastic molded chairs are usually shipped unassembled.

Upholstery. Most manufacturers use a continuous vinyl type (Naugahyde) or a fabric. High quality commercial vinyl is the easiest to clean and is extremely durable. Fabrics, however, are generally more comfortable, easier to repair when torn, and can be treated for stain resistance. Both vinyl and fabric upholstered seating can be reupholstered whenever necessary.

4 ITEM INDEX**CHAIRS**

C-1 ARM CHAIR - Oak wood frame, oiled natural wood finish, upholstered seat and back. 29½" H X 20" W X 20¼" D.

MADISON FURNITURE IND.

C-2 SIDE CHAIR, STACKABLE - Oak wood frame, oiled natural wood finish, upholstered seat and back, dowel rod construction.

CHARLOTTE CHAIR CO.

C-3 ARM CHAIR, DIRECTOR'S - Foam-padded seat and back, polished chrome tubular with welded joints. Plastic glides should be specified when not used on carpeting.

SHELBY-WILLIAMS IND.

C-4 ARM CHAIR: ALPINE CAPTAIN'S - Without upholstery, distressed Spanish Oak finish. 31" H X 22" W X 32" D.

SHELBY-WILLIAMS IND.

C-5 ARM CHAIR, CAPTAIN'S - Without upholstery, Acorn Brown finish.

A. BRANDT CO.

C-6 ARM CHAIR, NORDIC DECOR - Foam-padded spring seat, upholstered seat and back. 33" H X 23" W X 23" D. Grade 4 upholstery.

SHELBY-WILLIAMS IND.

C-7 SIDE CHAIR, LANCELOT - Upholstered spring seat and webbed back, Pacific Brown wood finish. 35" H X 21" W X 23" D. Grade 30 upholstery.

CHARLOTTE CHAIR CO.

C-8 SIDE CHAIR, STACKABLE - 18 gauge tubular steel frame with welded joints, upholstered seat and back. Grade 3 upholstery.

B. BRODY SEATING CO.

C-9 ARM CHAIR - Fiberglass shell, swivel pedestal base with casters, unupholstered. Specify shell color.

HERMAN MILLER



C-1



C-2

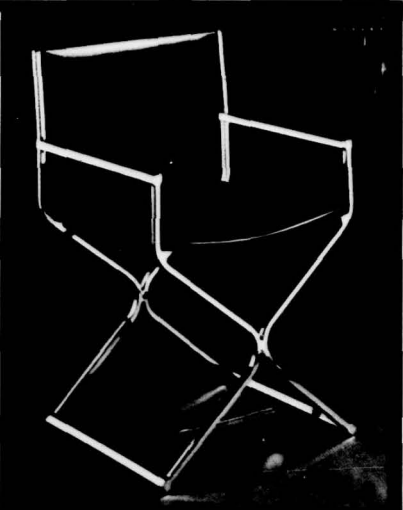

C-5



C-6



C-7



C-8



C-9

TABLES
BOOTH

Booths. The previous section generally applies to booth seating. Wooden frames are usually made from 1/2 to 1-inch plywood, reinforced with metal angles. The standard features include a crumb trough behind the seat and an inclosed base. Booths are usually covered completely with upholstery or in a combination of upholstery and plastic laminate. Various colors may be specified for both the upholstery and the plastic laminates.

Table Tops. Two kinds of tops are recommended: the solid hardwood, and the wooden core with a high-pressure laminated surface. The solid wood is desirable for its durability and appearance; in some cases "defacing" it may add to the general atmosphere, as in the "Pub" decor. The edges of the solid hardwood tops are usually as durable as the wood core with plastic laminates. Plastic laminate surfaces are available in a wide variety of colors, patterns, and textures. The "self edge," which is a plastic laminate, is adequate in most cases, and allows for easy abutment of rectangular tables for handling larger groups; however, the vinyl edge, at a slightly higher cost, is more abrasion- and chip-resistant and is recommended for seating that remains relatively fixed. A new process provides a "Contour" edge, which is a one-piece lamination of the top and edges. Since the table edge is the most critical area of damage, this new process appears to be a very satisfactory method because it eliminates seams at corners.

Pedestal Bases. The base is perhaps the most critical part of a table. Center pedestal bases allow more comfortable seating; however, the bases tip more easily than do tables with corner legs. This guide recommends central pedestal bases for dining facilities: each consists of a top spider, a column, and a base. The base should be of one-piece construction, welded to the column. The pedestal unit is usually assembled when shipped and then bolted to the pre-drilled tops at the job site.

T-1 TABLE TOP AND BASE - High-density particle board core with high pressure laminate surface covering top and edges in one piece-Contour edge (round top has 1 1/4" black vinyl edge). Base in bright chrome finish with self-adjusting glides.

FIXTURES MANUFACTURING CO.

T-1a 24" x 36" TOP with BASE number 4622-28.

T-1b 36" x 48" TOP with BASE number 4628.

T-1c 54" round TOP with BASE number 4636.

T-2 TABLE TOP AND BASE - Flake board core with high pressure laminate top; 1 1/4" black vinyl edge. Stabilizer 80 base with self-adjusting device guaranteed for 5 years; in satin chrome finish.

JOHNSON INDUSTRIES

T-2a 24" x 36" series 3000 TOP with BASE number J80-30.

T-2b 36" x 48" series 3000 TOP with BASE number J80-30x42.

T-2c 54" round series 3000 TOP with BASE number J80-42.

T-3 TABLE TOP AND BASE - High-density particle board core with high pressure laminate top; 1 1/4" black vinyl edge. Base with self-adjusting glides and black porcelain finish, polished chrome column. Tops pre-drilled, bases assembled.

FALCON PRODUCTS INC.

T-3a 24" x 36" series 13000 TOP and BASE number 203-2230.

T-3b 36" x 48" series 13000 TOP and BASE number 204-2230.

T-3c 54" series 13000 TOP and BASE number 204-30.

T-4 TABLE TOP AND BASE - 1 1/4" solid rock maple top in laminated stripe pattern. Cast iron spider on base, otherwise same as T-3.

FALCON PRODUCTS INC.

T-4a 24" x 36" 17000 series TOP and BASE number 203-2230.

T-4b 36" x 48" 17000 series TOP and BASE number 204-2230.

T-4c 54" round 17000 series TOP and BASE number 204-30.

B-1s SINGLE BOOTH - All-plastic laminate frame and crumb trough; three horizontal rows, deep bun tuft back; inclosed black linoleum base; plastic laminate outside finished back. 48" long, 3'-0" high.

SHELBY WILLIAMS IND.

B-1d DOUBLE BOOTH - Otherwise same as B-1s.

B-1w WALL BOOTH - 8'-0" long; otherwise same as B-1s.

B-2s SINGLE BOOTH - "Holiday"; all-plastic laminate frame, sides and back; channel tufted; removeable back; crumb trough; inclosed black linoleum base. 48" long, 3'-0" high.

B. BRODY SEATING CO.

B-2d DOUBLE BOOTH - Otherwise same as B-2s.

B-2w WALL BOOTH - 8'-0" long; otherwise same as B-2s.

B-3s SINGLE BOOTH - All hardwood construction; provincial-shaped top; random-planked back; open base; 4'-0" long, 3'-0" high.

SHELBY WILLIAMS IND.

B-3d DOUBLE BOOTH - Otherwise same as B-3s.

B-3w WALL BOOTH - 8'-0" long; otherwise same as B-3s.

B-4s SINGLE BOOTH - Wooden provincial top member; ebony finish; divided cushion-effect back with 5 rows button deep diamond tufts; wooden end trim and center plaster; inclosed black linoleum base; 4'-0" long, 4'-0" high.

SHELBY WILLIAMS IND.

B-4d DOUBLE BOOTH - Otherwise same as B-4s.

B-4w WALL BOOTH - 8'-0" long; otherwise same as B-4s.

B-5s SINGLE BOOTH - "Madrid"; oak-finished wooden decorative trim; removeable upholstered backs and seat; inclosed black linoleum base; 4'-0" long, 5'-0" high.

B. BRODY SEATING CO.

B-5d DOUBLE BOOTH - Otherwise same as B-5s.

B-5w WALL BOOTH - 8'-0" long; otherwise same as B-5s.



FLOOR
COVERINGS

Carpet. The quality of carpet depends on the quality of manufacturing; therefore, it is essential to purchase carpet made by a reliable mill. A good carpet should have a normal life expectancy of 8 to 15 years if it is properly maintained. Carpeting, along with acoustical tile ceilings, should have the highest priority where noise is a severe problem in a dining facility.

Fibers for commercial carpet are made almost exclusively of synthetic materials: nylon, acrylic, modacrylic, polypropylene, or polyesters. For optimum cleaning and wear, it is recommended that carpets installed in Army dining facilities be made of a continuous filament nylon. The following are technical requirements for carpet in enlisted personnel dining facilities:

- Surface Texture - Level loop or multi-level loop, tufted or woven, for direct glue-down installation without underlay.
- Pile Material - Bulked continuous filament nylon, modified to provide increased filament translucence or opacity for soil hiding.
- Static Control - Incorporation of a static control system to permanently control static buildup to less than 2500 volts when tested at 20% relative humidity and 70°F, in accordance with the American Association of Textile Chemist and Colorist test method 134-1969.
- Flame Spread - Carpeting system shall have a flame spread rating of 75 or less when tested in accordance with ASTM E84, or a flame propagation index of less than 4.0 when tested in accordance with UL 992.
- Primary Backing - 3.5 oz/S.Y. minimum polypropylene (tufted carpeting).
- Secondary Backing - 7 oz/S.Y. minimum stainless jute; 3½ oz/S.Y. minimum non-woven polypropylene (tufted carpeting).
- Tuft Bind* - Minimum 9 lb average pounds force when tested in accordance with ASTM D-1335.

*Fiber bundle encapsulation and latex penetration of the fiber bundle shall be such that the carpet will not pill, fuzz or beard.

Pile height, weight, and construction shall be as follows:

Type	Pile Weight/Height	Construction
Nylon level loop & multi-level loop	28 oz/S.Y. min pile weight; .187 in. min, .250 in. max pile height	Tufted 1/8 or 1/10 gage at 7 stitches per in. min.
		Woven Minimum 216 pitch at 7 rows per in. min.

Carpet Backing. All carpets have a primary backing and, depending upon the weave, a secondary backing. The primary backing should be of a synthetic (i.e. polypropylene, latex) to resist spillage, rot, and mildew. The secondary backing may be a natural material (i.e., jute)—but a synthetic is again preferred.

Tile. A hard-surface flooring is recommended for areas where spills and dirt spots are likely to occur (i.e., serving and self-service areas, vestibules, main traffic lanes, and customer toilets). A hard surface should be substituted for carpet when the principal customers of the facility are soldiers who track in considerable dirt.

Quarry tile is very durable, easy to maintain, highly attractive, and expensive to install. Pure vinyl tile is not as durable, but is available in a commercial grade, "no-wax" finish and many attractive patterns. Vinyl asbestos has a somewhat shorter life span than pure vinyl, requires waxing, and has limited styles—but is the most inexpensive for commercial use. Asphalt tile is not recommended for Army dining facilities.

Installation and Purchasing. To obtain a smooth surface transition where more than one type of floor covering is used, the construction details should be based on the layout of the building. A tile floor should be installed by professionally qualified personnel. The flooring manufacturer will supply a list of local distributors upon request.

AD-A074 902

CONSTRUCTION ENGINEERING RESEARCH LAB (ARMY) CHAMPAIGN IL F/G 13/13
DECOR GUIDE FOR ENLISTED PERSONNEL DINING FACILITIES.(U)

JUL 79 R L PORTER, B D BERSHAD, N HINTZ

IAO-DRXNM-76-174

UNCLASSIFIED

CERL-TR-E-150

NL

2 OF 2

AD
A074902

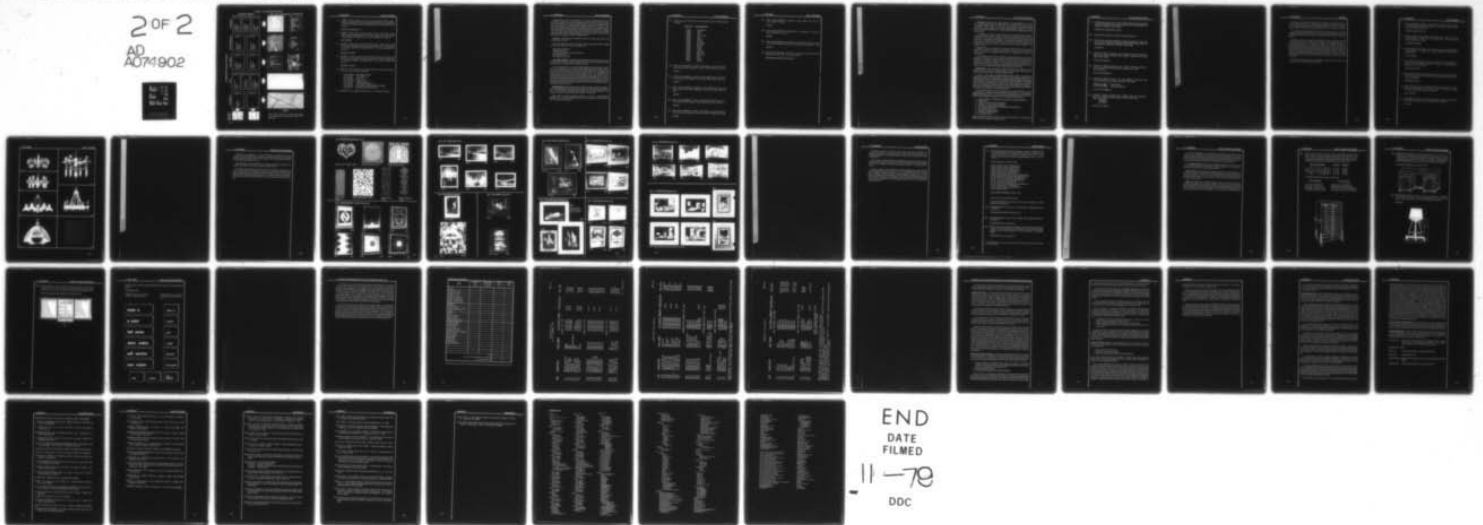

END
DATE
FILMED
11-79
DDC

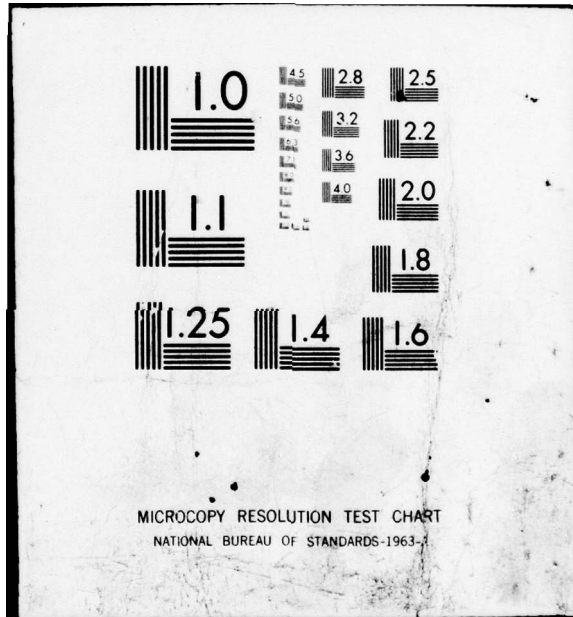

CARPET - TILE SUBSTITUTION GUIDE

SPECIFIED CARPET

VINYL TILE COORDINATED ALTERNATIVE

COORDINATED DESIGN PACKAGES

"PATTERNS"

Option 1 Carpet F-1 Neptune Tweed	Option 2 Carpet F-1 Avocado Tweed	Option 3 Carpet F-1 Red Tweed
--	--	--

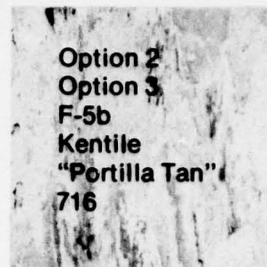

"CONTEMPORARY"

Option 1 Carpet F-1 Marigold Tweed	Option 2 Carpet F-1 Neptune Tweed
---	--

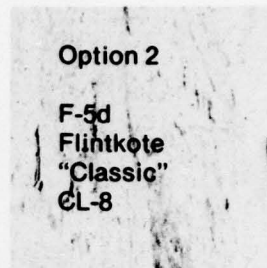
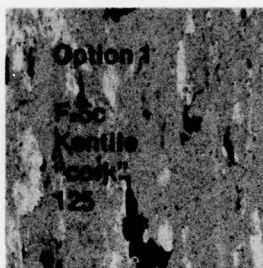

"SKI LODGE"

Option 1 Carpet F-1 Horizon Copper Tweed	Option 2 Carpet F-2 Neptune Tweed
--	--

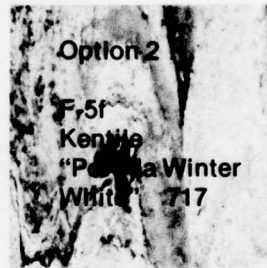
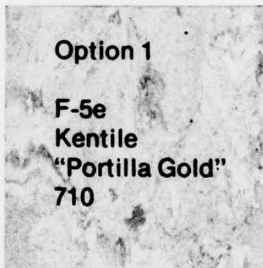

"PUB"

Option 1 Carpet F-3 Red	Option 2 Carpet F-1 Red Tweed	Option 3 Carpet F-1 Mahogany Tweed
-------------------------------	--	---

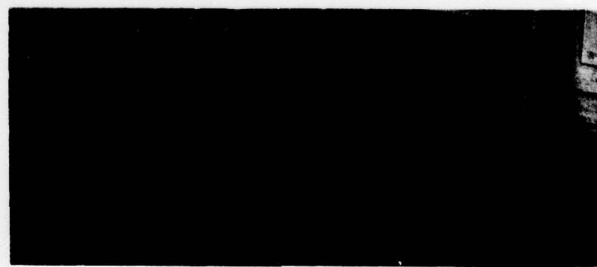

"EUROPEAN"

Option 1 Carpet F-4 Natural	No option
-----------------------------------	-----------

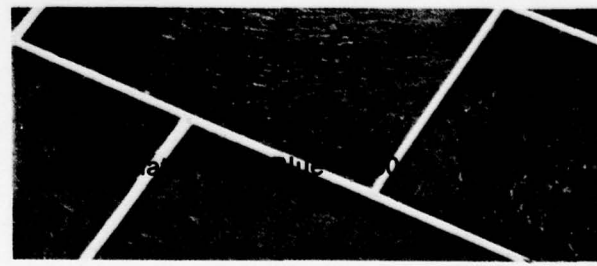

Flooring in the entry



NOTE: When vinyl tile is used in the entire dining area, same tile should be used in the entryway.

- F-1 CARPET—"New Checkstat"; Antron II nylon with static control; weave—velvet (woven high low loop pile); pile weight—28.8 oz/sq yd; pile height—.120" to .380"; backing—latex; total weight—50.0 oz/sq yd. Available in 12 ft width.

BIGELOW-SANDFORD, Inc.

- F-2 CARPET—"Task Force"; three-ply Antron II nylon with static control; weave—tufted; pile weight 28.1 oz/sq yd; pile height—.210"; primary back—polypropylene; secondary back—jute; total weight 65.1 oz/sq yd.

LEE'S CARPET

- F-3 CARPET—"Monte Cruz"; Anso-X nylon with static control; tufted cut-pile construction; pile weight—32 oz/sq yd; pile height—.438"; primary back—4 oz Tyvar (synthetic); secondary back—7 oz jute; total weight—77 oz/sq yd.

MONARCH CARPET

- F-4 CARPET—"Tektonic"; Anso-X nylon with static control; tufted cut pile construction; pile weight—40 oz/sq yd; pile height—.563"; primary back—4 oz Tyvar (synthetic); secondary back—7 oz jute; total weight—85 oz/sq yd.

MONARCH CARPET

- F-5 VINYL TILE—All reinforced vinyl; pattern formed by colored laminations; 12" X 12" X 1/8" minimum thickness.

- F-5a Flintkote "Blue Heaven" F739
- F-5b Kentile "Portilla Tan" 716
- F-5c Kentile "Cork" 125
- F-5d Flintkote "Classic" CL-8
- F-5e Kentile "Portilla Gold" 710
- F-5f Kentile "Portilla Winter White" 717
- F-5g Kentile Colonial Brick "Georgetown Red" 3ED95
- F-5h Kentile Barre Slate "Barre Blue" S160

- F-6 QUARRY TILE—Non-glazed surface, 6" x 6" x 1/2" minimum thickness.

WALL
COVERING

Paint. Painting is the most versatile and, initially, the least expensive of all wall surface treatments. A latex-based paint with a semi-gloss finish is generally recommended for all interior purposes because it is easy to apply and maintain. This material also allows the sub-surface materials to "breathe." Latex paints are available in several finishes, ranging from flat to high-gloss enamels. The differences among the degrees of gloss are primarily in the resin-to-pigment ratio (the higher gloss means higher resin content). The higher resin content enamels allow for easier cleaning; however, this higher resin content limits the quality and the available colors of these enamels.

Generally, walls should be repainted at least once every three years, and maintained by washing.

All paint selections should be made from Federal Specifications 595A. Three-by-five-inch color chips are available from:

Department of Defense
Single Stock Point
U.S. Naval Publications and Forms Center
5801 Tabor Avenue
Philadelphia, PA 19120

Vinyl Wall Coverings. These are recommended as having the maximum cost benefit for coverings that meet the DOD fire restriction criteria. These coverings are produced in a wide variety of styles and colors.

All vinyls should meet or surpass Federal Specification CCC-408a, Types II and III. For cleanability, all vinyls should also pass the industry's 24-hour stain test: after a 24-hour period, stains should be removeable with isopropyl (rubbing) alcohol. Vinyl coverings should be applied only to a completely flat surface (such as plaster). With concrete masonry units, each block must be covered with plaster or furring strips and drywall before applying the vinyl covering. Minor wall imperfections can be covered by a highly textured vinyl. Vinyls can easily cover painted surfaces, but raw concrete or new plaster should be primed and sealed first. Always use adhesives and follow the procedures recommended by the manufacturer.

Other Materials. Plywood paneling is popular with dining facility customers. It must meet the DOD fire rating of Class I (Class A), which requires an application of fire retardant. Although this treatment may be more expensive, the decorative effects achieved with plywood make it worthwhile.

High pressure plastic laminate panels (i.e. Formica, Johns-Manville Melamite, etc.) provide a durable surface and are available in a wide variety of colors, textures, and patterns.

W-1 PAINT—Must be selected from the following Federal Standard 595a numbers:

Federal No.	Descriptive Name
30045	Dark Brown
34138	Green
30266	Tan
27855	Pale Yellow
32169	Rust
30318	Neutral
37769	Neutral
35250	Med. Blue
35183	Dark Blue
34230	Green
33448	Neutral
33538	Yellow
34151	Dark Olive
34258	Med. Olive
30160	Maroon
31136	Red
36357	Neutral
37769	Neutral

W-2 VINYL WALLCOVERING—"Alestria"; total weight—18.7 oz/sq yd; vinyl—13.6 oz/sq yd; fabric backing 5.1 oz/sq yd. Color: Sundown. 54" wide.

VICRTEX

W-3 VINYL WALLCOVERING—"Labyrinth"; total weight—20 oz/sq yd; vinyl—14.9 oz/sq yd; fabric backing—5.1 oz/sq yd. Color: Walnut. 54" wide.

VICRTEX

W-4 VINYL WALLCOVERING—"Pembrook"; total weight—16.6 oz/sq yd; vinyl—13.0 oz/sq yd; fabric backing—3.6 oz/sq yd. Color: Peach. 54" wide.

VICRTEX

W-5 VINYL WALLCOVERING—"Tibor"; total weight—16.6 oz/sq yd; vinyl—13.0 oz/sq yd; fabric backing—3.6 oz/sq yd. Color: Teal. 54" wide.

VICRTEX

W-6 VINYL WALLCOVERING—"Taiwan"; total weight—17.3 oz/sq yd; vinyl—13.7 oz/sq yd; fabric backing—3.6 oz/sq yd. Color: Tangerine. 54" wide.

VICRTEX

W-7 VINYL WALLCOVERING—"Conquest"; total weight—21.3 oz/sq yd.
Color: Natural. 54" wide.

GENON

W-8 VINYL WALLCOVERING—"Parquet Cork"; total weight—17.3 oz/sq yd.
Color: Burnt Cork. 54" wide.

GENON

W-9 VINYL WALLCOVERING—"Stonehenge"; total weight—20 oz/sq yd; vinyl
—14.9 oz/sq yd; fabric backing—5.1 oz/sq yd. Color: Sea Sand. 51" wide.

VICRTEX

W-10 CORK WALLCOVERING—"Corticiera"; natural cork mounted on fabric
backing. Color: Dark. 49" wide, up to 30 yd roll.

MIDWESTERN DISTRIBUTION CENTER

PARTITIONS
DRAPERY

Partitions. These serve two basic functions in a dining facility: (1) to provide visual/physical privacy for customers, or to separate traffic flows, and (2) to provide limited control of noise. For these functions, any physical screen (partitions, panels, drapery, etc.) would be appropriate; however, to provide privacy without total isolation, the solid fixed partitions, approximately 6 feet high, are best.

For partitions to act as a noise control element, they should have a noise reduction coefficient (NRC) of .85 or higher. GSA classifies these partitions as "acoustical," and they are available in a wide variety of fabric coverings. They should be free-standing and moveable to facilitate rearrangement within the dining area, and should be a high priority where carpet is not provided. Fixed partitions can achieve "acoustical" quality by having carpet installed on the vertical surfaces.

Drapery. Fabrics are available in an almost unlimited variety of colors, styles, patterns, and weaves. To meet DOD requirements, the fabric must be flame retardant. A modacrylic, fiberglass, treated cotton or treated blend will meet these requirements.

Divider drapes may be used as economical space dividers and as a means of adding visual variety, but should be used with discretion to avoid restricting air movement. The length of divider drapes will be from the track, mounted on the underside of girders and beams, to 1 inch above surface of the carpet. Track should run the full width of the bay being subdivided, normally from column to column or from column to wall. Divider drapes will be hand traverse.

Measurement. For procurement purposes, estimate the yardage of fabric required by using twice the window width for each window. The drapery installer should be consulted for the exact measurements.

For one- or two-company dining facilities, the drapery fabric, its tailoring and installation, should be contracted from a local firm for the greatest efficiency. On larger projects, funds can be saved by procuring materials through a manufacturer and having that firm or a local firm tailor and install the drapery. The drapery hardware should be supplied by the same firm to insure that the proper items for the job are provided. Contractor should verify all dimensions and yardage required to provide draperies at a minimum of 100 percent fullness using Clickeze, Verti-pleat or a comparable accordian fold system.

The installation costs vary with the size of the job, the kind of fabric, and the specifications; an estimate should be obtained from a local firm. The following general specification items for French or box-type pleats can serve as a guide for draperies of sill length as measured from 5 inches above window frame:

1. Double-turned 4-in. heading over a permanent type heading stiffener
2. Tacked pleats
3. Double 1½-in. side seams blindstitched
4. Double 4-in. bottom hems blindstitched
5. Overlocked serged multiple widths with safety locked stitch
6. 3-in. overlap and returns
7. Finished to measured length
8. Pleated to measured width
9. Fan-folded and tied.

Draperies should be lined if the fabric is not a casement type (i.e., loose weave) and the window is subjected to direct sunlight.

- P-1 PARTITION—Acoustical type (NRC = 0.90) free standing; open style base; number 6278 Maple Texture; flame-resistant fabric; bronze-finished trim. Height 56", width 36". Legs included.

ACOUSTICAL SCREENS IN COLOR

- P-2 PARTITION—Height 56", width 60", otherwise same as P-1.

- P-3 PARTITION—Acoustical type (NRC = 0.85); free standing; 2" base opening from floor; number DF-1335 Hawaiian Sand; flame resistant fabric; fabric-finished trim. Height 60", width 60". Legs included.

INTEROYAL

- D-1 DRAPERY FABRIC—Casement type; "Colorbell Verel"; 70% Verel modacrylic, 30% rayon; permanently flame resistant. Available in 54" width. Specify color—Sable

CORAL OF CHICAGO

- D-2 DRAPERY FABRIC—Casement type; "Aaron"; 70% Verel modacrylic, 30% rayon; permanently flame resistant. Available in 48" width. Color—Charcoal

PAYNE AND COMPANY

- D-3 DRAPERY FABRIC—"Atkins"; 41% Verel modacrylic, 35% saran, 24% rayon; permanently flame resistant. Available in 48" width.

ORDER NO. 82627 COLOR: Blue
ORDER NO. 82628 COLOR: Green/Gold

PAYNE AND COMPANY

- D-4 DRAPERY FABRIC—Casement type; "Rapalla"; 70% verel modacrylic, 30% rayon; permanently flame resistant. Available in 48" width.

Colors—Green Gold
 Red Melon
 Gold Melon

CORAL OF CHICAGO

LIGHTING

The quality, intensity, and distribution of lighting has a definite effect on colors, the appearance of food, and the overall comfort of the customers. Generally, warm light provides the best atmosphere in a dining area. It is the most complimentary to food color and warm-colored decor (i.e., reds and yellows).

Since lighting intensity affects the "mood" of the dining area, it is recommended that the lighting be varied from meal to meal. Varying the distribution of fixtures also affects the light intensity and creates visual interest in particular locations.

Whenever possible, a decorative incandescent fixture should be provided and coordinated with the decor. Dimmer switches are an inexpensive way of controlling the intensity of incandescent lights. If fluorescent fixtures are already installed and it is not feasible to replace them, deluxe cool-white or warm-white tubes should be used to improve light quality. This effect can also be achieved by using a tinted fixture diffuser or lens (see item L-7). New fluorescent fixtures can be equipped to use dimmer switches; however, since it is usually prohibitively expensive to equip existing fixtures for dimming, a series of switches to control the number of fixtures in use at any one time should be considered.

In all cases the installation or modification of lighting systems should be planned and executed by qualified personnel.

- L-1 LIGHT FIXTURE—Chandelier; burnished brass and dark walnut finishes; tole-styled shades; spread 22", height 19½", overall 45". Uses four up to 60 watt candelabra base lamps.

THOMAS INDUSTRIES, INC.

- L-2 LIGHT FIXTURE—Hand-rubbed, aged copper finish ringed by six drip candles; spread 19", height 18½", overall height 37". Uses six up to 60 watt candelabra base lamps.

THOMAS INDUSTRIES

- L-3 LIGHT FIXTURE—Chandelier; center column is walnut with polished brass fittings; spread 21½", height 14½", overall height 32½". Uses five up to 60 watt bulbs.

HALO LIGHTING

- L-4 LIGHT FIXTURE—Chandelier; American Bronze finish; frosted glass; distressed black metal shade; diameter 31", height 15", overall height 41". Uses five up to 75 watt bulbs.

FELDMAN LIGHTING

- L-5 LIGHT FIXTURE—Chandelier; distressed black with pecan and weathered-iron finishes; diameter 40", height 23", overall height 49". Uses six up to 150 watt globelights.

FELDMAN LIGHTING

- L-6 LIGHT FIXTURE—One-light, shaded drop type; fruitwood finish frame with woven cane panels; 8" opal sphere; spread 18½", height 15", length 33". Uses medium base bulb up to 150 watts.

HALO LIGHTING

- L-7 DIFFUSER—Tinted lens; for existing fluorescent fixtures; specify KSH-19 in Bronzetones and exact size of old lens; 5/32" thickness.

K-S-H INC.

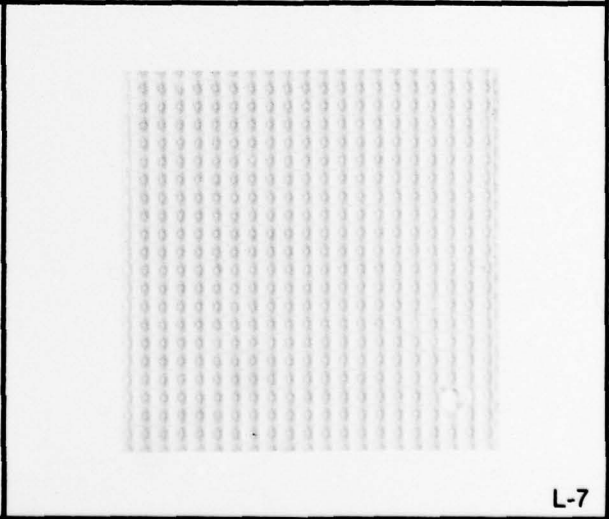
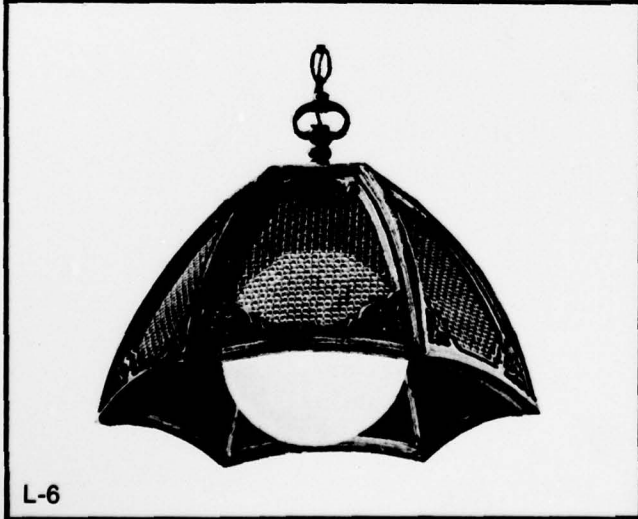
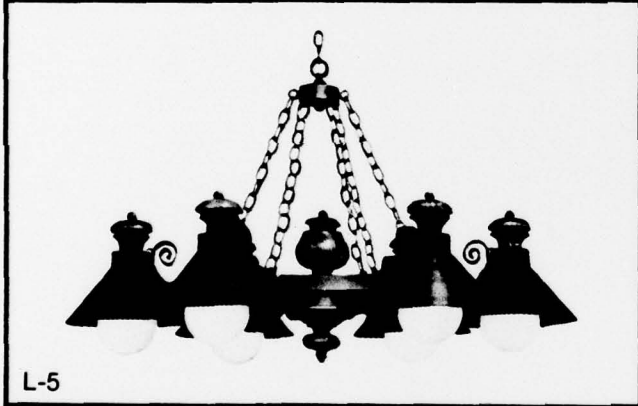
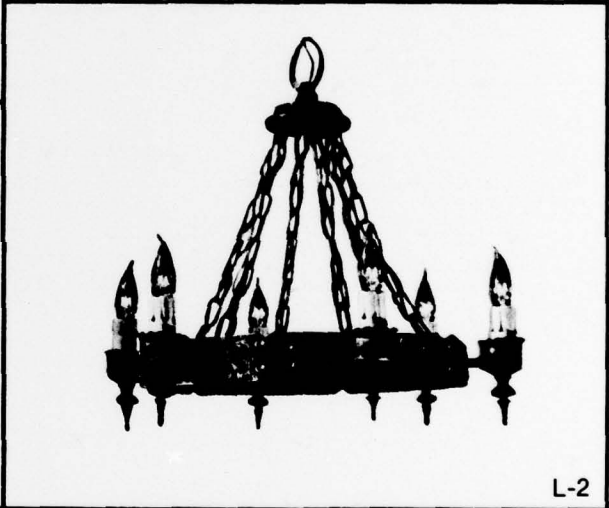
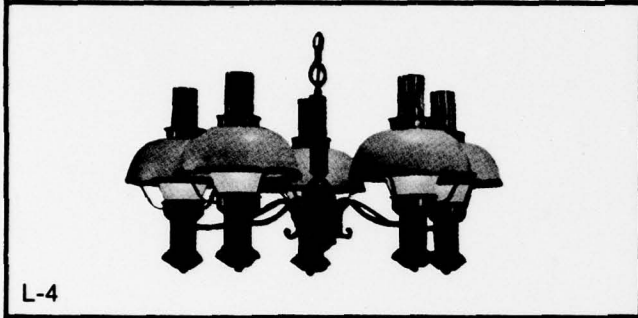
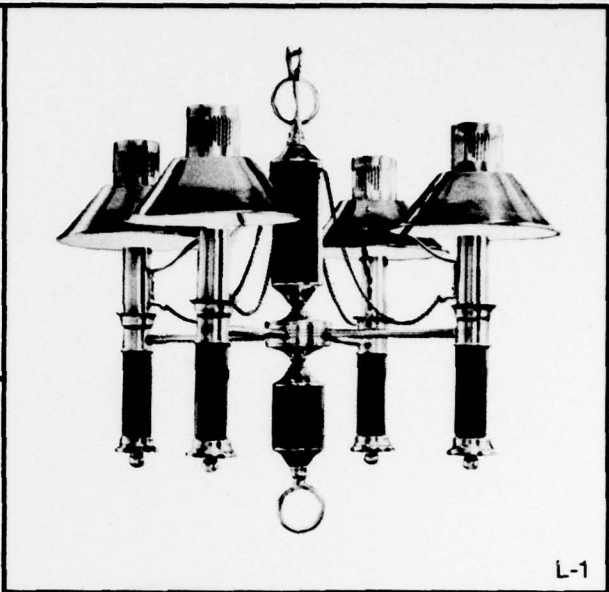
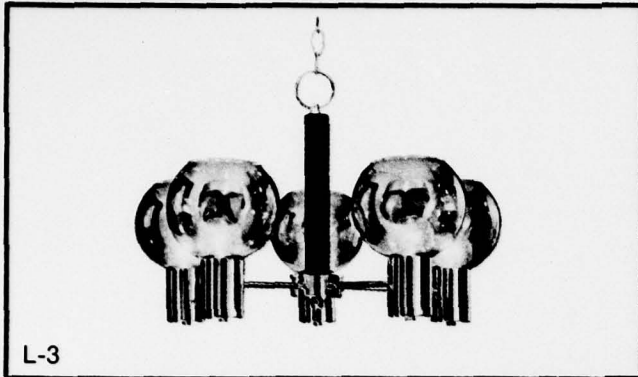

DECORATIVE
ACCESSORIES

Paintings, wall sculptures, and other decorative accessories create and accent the interior design theme. These items generate focal points of interest by breaking up continuous wall and floor surfaces. The theme should be carried into the waiting line areas as well.

Wall hangings may be periodically exchanged among dining facilities to maintain continued interest and to create a "dynamic decor."

Accessories of the same style should be used in a variety of sizes and subjects to create interest and develop a stylistic atmosphere. Paintings can be hung most effectively in groups rather than one every few feet. The following pages contain examples of accessory items. For a more complete list of selections, contact the individual manufacturers or local distributors listed with each item.

DA-1 BANNERS (Herman Miller, Inc.)



#3017 LOVE HEART 47X47

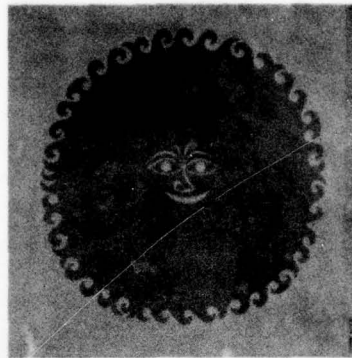

#3015 OLD SUN 47X47



#3006 PALACE 47X47



#3040 KILIM
23X58

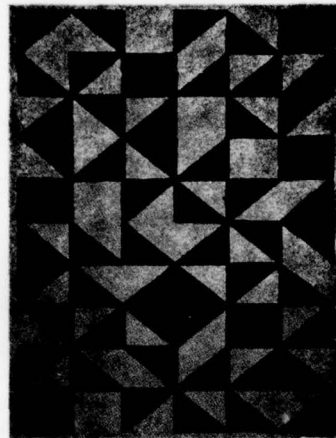

#3003 GEOMETRIC 47X58



#3023 CIRCLE
23X65



#3002 CROSSES
23X65

DA-2 CONTEMPORARY PRINTS (Turner, Inc.)



LE279

Y320

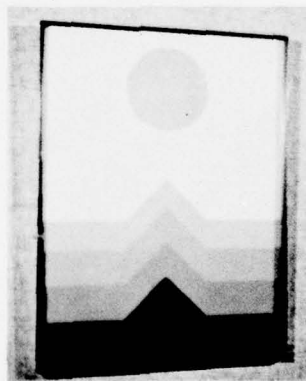

A905

C72



LE279

V321

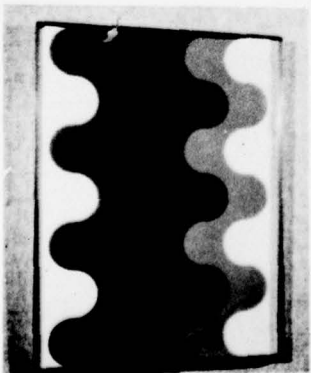

A873

C97

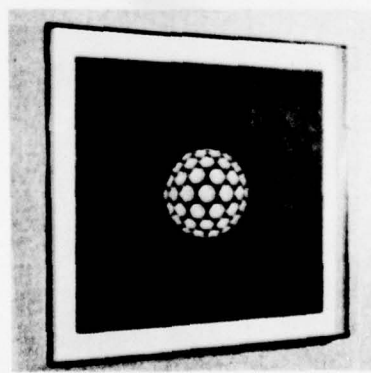

A605

C122

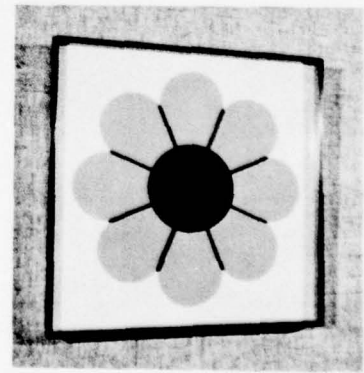

A899

C69

DA-3: SKI LODGE (Turner, Inc.)



2758

T628



3726

S13

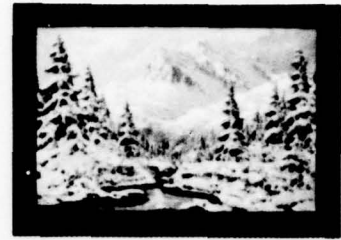

2718

N105



3726

V2

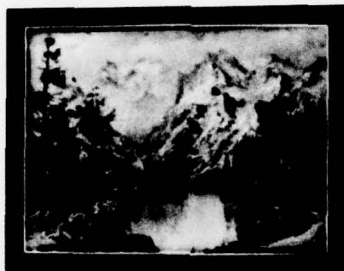

3726

S51



2718

742

DA-4 SKI LODGE (Yorkcraft)



Ski-1 Poster



Ski-2

Poster

4-32

DA-5: SKI LODGE (Turner, Inc.)

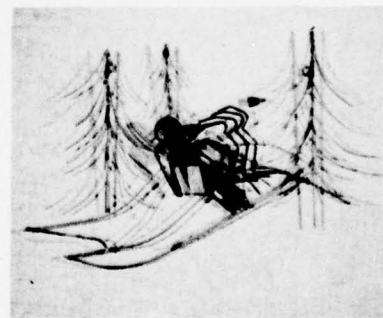

Skier

A508

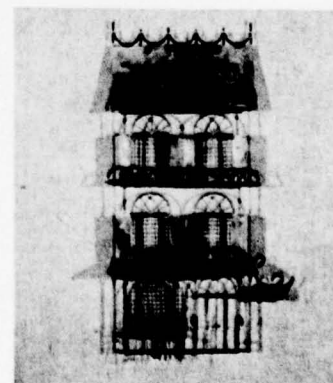

Town House

A507

DA-6: PUB SPORTS (Academy Arts)



Runner

7861



Serve

7856

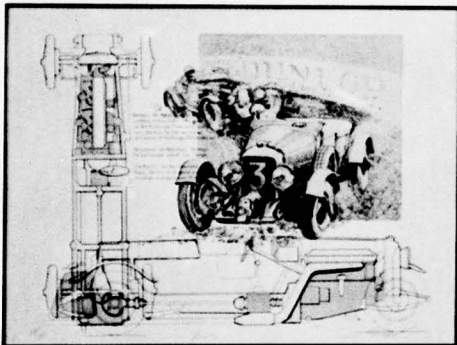

Bentley

7868

DA-7: PUB SPORTS (Turner, Inc.)



2685

J765



3621

B245



3624

H407



3623

H40

DA-8: PUB WESTERN (Academy Arts)



8026

(All examples come in groups of four prints)

8027

7826B



DA-9: PUB SALOON (Turner, Inc.)



A873

C117

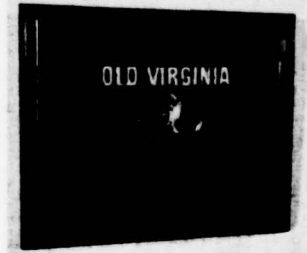

A873

C116



A871

C93



A871

C94

DA-10: EUROPEAN (Turner, Inc.)



C760

T736



C760

T165

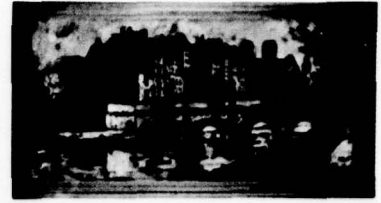

C760

L30



C760

V73



C760

L35



C760

T45

DA-11: EUROPEAN (Academy Arts)



8881



8881



8337 Street Scenes come as a set of four Prints

SOUND

Customers complain of the high noise level caused by the clattering of dishes and glasses in the dining facility. Carpet, partitions, draperies, and upholstered furniture can greatly reduce the noise from the kitchen and dish-washing areas.

A PA system with background music capability would also mask the objectionable sounds, as well as enhance the dining atmosphere. The sound system controls with a paging microphone should be located in the dining facility office.

The 3M "Cantata" system described on page 4-36 does not receive FM-AM stereo broadcasts from local stations, nor is it compatible with other than 3M tape cartridges. Therefore, before a sound system is selected for a dining facility, the existing sound systems on the base should be thoroughly reviewed with the electronics group. Compatibility with the existing sound system and maintenance capabilities for interchanging equipment must be considered before purchase.

SS-1 BACKGROUND MUSIC SYSTEM, 3M Brand, "Cantata" 700 Model 94 BG; uses 3M prerecorded music libraries (special type of cartridge), each of which contains 80 to 700 selections; amplifier can drive up to 30 speakers; complete ready to plug into speaker system; 12½" w, 16¼" d, 7 1/8" h.*

Music cartridges for "Cantata" 700:

R-165 - Rhythmic Library, 700 Selections
 R-266 - Rhythmic Library, 700 Selections
 M-165 - Melodic Library, 700 Selections
 M-266 - Melodic Library, 700 Selections
 V-168 - Variety Library, 700 Selections
 RX-266 - Rhythmic Christmas Library, 350 Selections
 MX-266 - Melodic Christmas Library, 350 Selections
 VX-167 - Christmas with Vocals, 350 Selections
 CX-167 - Continuous Christmas, 80 Selections
 PL-166 - Polynesian, 200 Selections
 SL-167 - Sacred Library (with vocals), 200 Selections
 SL-267 - Sacred Library, 130 Selections
 A-169 - American Country, 300 Selections
 MR-170 - Modified Rock

3M BUSINESS PRODUCTS SALES, INC.

Additional item under above contract:

3M Stand Microphone w/volume control. (Use for paging or public address w/Cantata 700.)

SS-2 SPEAKER, 3M 8" round, 8 ohm, w/70V transformer. (Baffle required for installation.)

3M BUSINESS PRODUCTS SALES, INC.

SS-3 SPEAKER, B260-8, 8" round, 2.16 oz magnet, 8 ohm. (Baffle required for installation.)

SOUNDOLIER, INC. (Commercial).

SS-4 BAFFLE, surface mounted, model 260-8; aluminum enclosure to accommodate an 8" round speaker; one required for each ceiling-mounted speaker. (Similar baffle available for flush mounting in suspended ceiling.)

SOUNDOLIER, INC. (Commercial).

*"Cantata" system does not receive FM-AM stereo broadcasts from local stations and is compatible only with 3M cartridges.

MISC
EQUIPMENT

The use of **tray racks** is recommended. Even though a tray-return window may exist near the kitchen, this procedure should be considered, since it eliminates the traffic conflict that occurs when some customers line up to return their trays to the kitchen area while others are waiting to be served. The elimination of this annoyance should contribute to improved customer satisfaction.

The **signature counter** should provide adequate space for the functions of check-in, cash collection, and storage of related paraphernalia. It may be fabricated locally according to the listed description.

Menu boards are an efficient and attractive means of communicating the day's meals. They should be located near the signature counter and placed at a convenient height for "seeing" and for changing the letters. Menu boards are available in a wide variety of sizes and styles, and should be specially fabricated to fulfill specific needs.

Signs can complement any Design Package if their size and letter style are carefully coordinated with the design theme. If signs are made locally rather than purchased from a manufacturer, special care must be taken to ensure that they do not detract from the overall decor. It is recommended that signs be hung from the ceiling by thin wires at a height of 7' 0" from floor to bottom of sign.

ME-1 RACK, SOILED TRAY—Aluminum alloy construction; bumpers; two sides inclosed; mobile; wide-tread, heavy-duty 5" neoprene tires. Rust proof, will accommodate trapezoid and standard type trays; sure hold suspension tray system prevents tray fallout; two swivel and two stationary wheels; brakes; push-pull handle; will not corrode or peel.

Nominal Dimensions			Tray Size	Capacity	
34	7/16" W	18 3/4" D	69 3/4" H	14" x 18"	22 Tray
35	15/15" W	23 1/4" D	69 3/4" H	15" x 20"	22 Tray
41	15/16" W	30 1/4" D	69 9/16" H	14" x 18"	44 Tray
	46" W	31" D	69 9/16" H	15" x 20"	44 Tray

PLANNING GUIDANCE: Per Dishwashing Area:

22-Tray Capacity

Two each, serving 40-80
 Four each, serving 81-150
 Eight each, serving 151-250
 Twelve each, serving 251-400

44 Tray Capacity

Eight each, serving 401-650
 Sixteen each, serving 651-1000
 Twenty-two each, serving 1001-1500
 Thirty-two each, serving 1501-2200

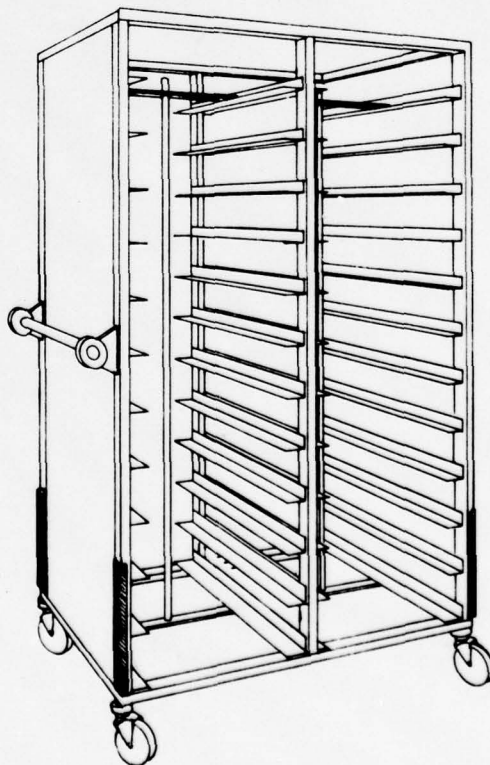

ME-2 SIGNATURE COUNTER—Nominal dimensions: 6' 0" w, 2' 0" d, 3' 0" h; wood grain laminated plastic sides and top to match tables and booths; caster mounted, 3" diameter ball casters with brakes; 6" black toe base, lockable drawers and doors for storage of cash register and documents. Item locally fabricated; design may vary to meet local requirements.

PLANNING GUIDANCE: One per serving line.

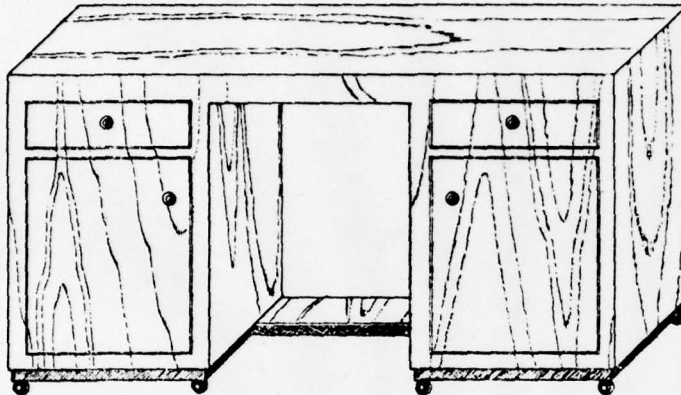

ME-3 SIGNATURE COUNTER STOOL—"Aries"; pneumatically adjustable stool; 5-blade swivel base on glides; fiberglass shell with vinyl seat cushion. Shell color: black, vinyl. Color: Moonglow (off white).

KRUEGER

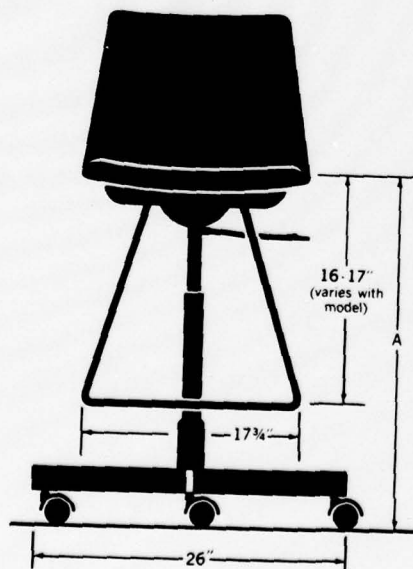

ME-4 MENU BOARD—Three individual removeable sections; glass hinged overall door; satin chrome frame. Vinyl-covered boards (supply color sample), 55" x 22". Contact manufacturer for other sizes and letter sets.

BULLETIN BOARDS AND DIRECTORY PRODUCTS, INC.

<p>FRUITS & DESSERTS</p> <p>BAKED APPLE 20 FRUIT SALAD 20 FRUIT JELLO 15 GRAPE FRUIT 20 CANTALOUPE 25 RICE PUDDING 20 BREAD PUDDING 20 STEWED PRUNES 20 SLICED ORANGES 20 SLICED PEACHES 20 HONEY DEW MELON 25 CABINET PUDDING 15 SLICED PINEAPPLE 20 CHOCOLATE PUDDING 15 STRAWBERRIES & CREAM 50 HOME MADE APPLE PIE 20</p>	<p>SPECIAL TODAY</p> <p>SOUP</p> <p>VEGETABLE 15 CLAM CHOWDER 25</p> <p>FISH</p> <p>BAKED HALIBUT 75 BROILED SEA BASS 60</p> <p>ENTREES</p> <p>BAKED VIRGINIA HAM 85 ROAST LEG OF LAMB 75 BROILED LIVER STEAK 80 ROAST SIRLOIN OF BEEF 95</p>	<p>STEAKS & CHOPS</p> <p>CUBE STEAK 65 LAMB STEAK 60 SWISS STEAK 75 SIRLOIN STEAK 125 VEAL CUTLET 85 LIVER & BACON 75 LONDON BROIL 65 DELMONICO STEAK 75 HAMBURGER STEAK 85 TENDERLOIN STEAK 150 PORTERHOUSE STEAK 175 BREADED VEAL CHOP 85 BROILED PORK CHOPS 75 BROILED LAMB CHOPS 85 VIRGINIA HAM STEAK 80</p>
<p>CHICKEN ALA KING 85</p>		

SIGNS—plastic laminate, neutral light plaque with black letters, factory-applied lettering.

HERMAN MILLER

AO343LN, 7-3/8" h x 23-13/16" w,
2" letters, order in boxes of 2.

AO342LN, 7-3/8" h x 11-13/16"
w, 7/8" letters, order in boxes
of 5.

enter ▶

check in

◀ enter

entrees

full menu

grill

short orders

salads

self service

desserts

rest rooms

beverages

men

women

**tray
deposit**

5 BUDGETING WORKSHEETS AND PRICE LIST

5 BUDGETING WORKSHEETS FOR COST ESTIMATES/PRICE LIST

The budgeting and cost estimating procedures illustrated here are designed to assist users of this guide in compiling lists of items required to implement selected decor packages. The worksheets may be completed by working with (1) layout drawings, (2) Item listing pages, (3) the Item Index, and (4) the current Price List. Layout drawings may be derived from Section 2, or if those drawings are not applicable, from individual facility layout drawings. Item listings are contained in Section 3 and pertain to individual Design Packages. The Item Index in Section 4 provides descriptions and illustrations for making individual item selections. This information, together with the price lists, should enable cost estimating for each improvement plan to be considered.

The price list contains the Decor Guide code numbers, manufacturers' names, their item order numbers, GSA contract numbers (with expiration dates), and item unit cost. When manufacturers are indicated, local suppliers should be used. The products of these manufacturers and suppliers are listed only to establish quality and color and are not intended to restrict or limit competition. Manufacturers' GSA contract numbers and prices will be updated periodically and distributed to guide users. If the price list in this guide is more than 12 months old prices should be verified directly with the listed manufacturers.

DECOR PRICE LIST
As of 1 December 1978

<u>CODE</u>	<u>MANUFACTURER</u>	<u>MODEL NUMBER</u>	<u>GSA CONTRACT NUMBER</u>	<u>EXPIRATION DATE</u>	<u>UNIT COST</u>
			CHAIRS (FSC 7110)		
C-1	Madison Furniture	C94E05	GS-00S-41855	09/79	\$ 65.00
C-2	Charlotte Chair	2043S	GS-00S-41878	09/79	75.00
C-3	Shelby Williams	9520	GS-00S-41849	09/79	65.00
C-4	Shelby Williams	8835	GS-00S-41849		60.00
C-5	A. Brandt	7105-00-687-8871			
C-6	Shelby Williams	2485	Commercial		
C-7	Charlotte Chair	707	GS-00S-41878	09/79	101.00
C-8	B. Brody Seating	435	GS-00S-41910	09/79	30.00
C-9	Herman Miller	PAC-00	GS-00S-41874	09/79	83.00
			TABLES (FSC 7110)		
T-1a	Fixtures Manuf.	Page 4-8	GS-00S-41962	09/79	70.00
T-2b	Fixtures Manuf.	Page 4-8	GS-00S-41962		140.00
T-3c	Fixtures Manuf.	Page 4-8	GS-00S-41962		201.00
T-2a	Johnson Industries	Page 4-8	GS-00S-61191	09/79	110.00
T-2b	Johnson Industries	Page 4-8	GS-00S-61191		130.00
T-2c	Johnson Industries	Page 4-8	GS-00S-61191		180.00
T-3a	Falcon Products	Page 4-8	GS-00S-41963	09/79	35.00
T-3b	Falcon Products	Page 4-8	GS-00S-41963		48.00
T-3c	Falcon Products	Page 4-8	GS-00S-41963		92.00
			BOOTHS (FSC 7105)		
B-1s	Shelby Williams	501	GS-00S-41849	09/79	182.00
B-1d	Shelby Williams	501 Double	GS-00S-41849		275.00
B-1w	Shelby Williams	501 Wall	GS-00S-41849		45.00/lf
B-2s	B. Brody Seating	HC-101-F36	GS-00S-41910	09/79	194.00
B-2d	B. Brody Seating	HC-102-F36	GS-00S-41910		342.00

lf = linear foot

DECOR PRICE LIST (Cont'd)

<u>CODE</u>	<u>MANUFACTURER</u>	<u>MODEL NUMBER</u>	<u>GSA CONTRACT NUMBER</u>	<u>EXPIRATION DATE</u>	<u>UNIT COST</u>
B-2w	B. Brody Seating	HC-000-26	GS-00S-41910		59.00/1f
B-3s	Shelby Williams	544	GS-00S-41849	09/79	175.00
B-3d	Shelby Williams	544 Double	GS-00S-41849		310.00
B-3w	Shelby Williams	544 Wall	GS-00S-41849		47.00/1f
B-4s	Shelby Williams	589	GS-00S-41849	09/79	325.00
B-4d	Shelby Williams	589 Double	GS-00S-41849		477.00
B-4ws	Shelby Williams	589 Wall	GS-00S-41849		80.00/1f
B-5s	B. Brody Seating	M-101-F-60	GS-00S-41910	09/79	325.00
B-5d	B. Brody Seating	M-102-F-60	GS-00S-41910		470.00
B-5w	B. Brody Seating	M-000-60	GS-00S-41910		92.00/1f

DECORATIVE ACCESSORY (FSC 7105)

DA-1	Herman Miller	EE517 Love Heart	Commercial		34.00
DA-1	Herman Miller	EE515 Old Sun	Commercial		43.00
DA-1	Herman Miller	EE505 Palace	Commercial		43.00
DA-1	Herman Miller	EE540 Kilim	Commercial		31.00
DA-1	Herman Miller	EE523 Circle	Commercial		31.00
DA-1	Herman Miller	EE502 Crosses	Commercial		30.00
DA-4	Yorkcraft Inc.	Ski-1**	GS-00S-41619	04/79	45.00
DA-4	Yorkcraft Inc.	Ski-2**	GS-00S-41619		45.00

MISCELLANEOUS EQUIP (FSC 7110)

ME-3	Krueger	6065-VFS Aries	Commercial		140.00
ALT 3	Krueger	6075-UF Gemini Alt	Commercial		100.00
ME-4	Bulletin and Direct	300 Letter Board	Commercial		290.00

FLOOR COVERINGS (FSC 7220)

F-1	Bigelow-Sanford	Checkstat	GS-00S-41409	03/79	
F-2	Commercial Carpet Corp	Item 274-46	GS-00S-61008	11/79	
F-2	Lees Carpet	Item 274-30	GS-00S-41230	11/79	
F-3	Monarch Carpets	Monte Cruz	Commercial	11/78	
F-4	Monarch Carpets	Textonic	Commercial		

Requisitioners for carpeting must comply with the requirements of DA Circular 210-24, Carpet Policy for Army Installations, prior to submitting requisitions to this Agency.

DECOR PRICE LIST (Cont'd)

<u>CODE</u>	<u>MANUFACTURER</u>	<u>MODEL NUMBER</u>	<u>GSA CONTRACT NUMBER</u>	<u>EXPIRATION DATE</u>	<u>UNIT COST</u>
			<u>WALL COVERINGS (FSC 5640)</u>		
W-1	Locally	Paint	Commercial		\$8.16 lin.yd
W-2	Vicrtex	Aletria	Commercial*		8.63 lin.yd
W-3	Vicrtex	Labyrinth	Commercial*		5.53 lin.yd
W-4	Vicrtex	Pembrook	Commercial*		5.53 lin.yd
W-5	Vicrtex	Tibor	Commercial*		8.02 lin.yd
W-6	Vicrtex	Taiwan	Commercial*		
W-7	Genon	Off White	Commercial		
W-8	Genon	Burnt Cork	Commercial		
W-9	Vicrtex	Stonehenge	Commercial*		8.63 lin.yd
W-10	Midwestern Distr.	Corticiera	Commercial		8.63 lin.yd
			<u>PARTITIONS AND DRAPES (FSC 7195)</u>		
P-1	Hoover Systems	SS3656BF	GS-00S-00157	04/79	190.00
P-2	Hoover Systems	SS6056FP	GS-00S-00157		190.00
P-3*	Interoyal	A06060S1	GS-00S-		
D-1	Coral of Chicago	Colorbell	Commercial		
D-3	Payne and Company	Atkins	GS-01S-06465	09/79	6.50 sq.yd
D-4	Coral of Chicago	Rapalla	Commercial		
			<u>LIGHT FIXTURES AND SOUND SYSTEM</u>		
			<u>DELETED NOT NUG FUNDED</u>		

Decor items not on this price list are obsolete and no longer available. Inquiries pertaining to decor items and accessories may be obtained by contacting the appropriate GSA Customer Service Office, (Attached at Inclosures 1 and 2).
 *Contracts are being negotiated by GSA.
 **Prints shown in Decor Catalog are limited in quantity. Specify whether substitution by the manufacturer with a similar type print will be acceptable.

APPENDIX A: DECOR DESIGN PRINCIPLES TO BE CONSIDERED IN RENOVATION

Several principles related to the operation of dining facilities may be of value when undertaking improvement projects. The principles of lighting and color, serving and layout functions, and sound control are briefly discussed.

Lighting and Color. In dining facilities the important functions of light are to illuminate the space for cleaning purposes, present food in an appetizing fashion, and enhance the surroundings. Proper lighting is especially important at the serving lines. "Warm" lighting such as incandescent or fluorescent (regular or deluxe warm-white) is appropriate and achieves the desired effects. On the other hand, while "warm" illumination may be preferred in the dining area, a "cool white" type of illumination is best for the working environment of food preparation, storage, and warewashing areas.

Lighting can create visual interest. Stark, white light of unvarying intensity should be avoided in favor of variety and color. Methods for controlling lighting interest include the use of dimmers (rheostats) to change intensity, moveable light sources (track lighting), and color diffusers for fluorescent fixtures.

A common fault of interior lighting in dining facilities is over-illumination. High-level lighting may serve to increase the rate of customer movement through the dining facility when required; however, soft, diffused lighting is preferred to help create the necessary relaxation while dining.

Attractive colors improve or enhance the decor in Army dining facilities. Since a young military population may generally prefer bright colors, drab or colorless facilities can be easily and inexpensively brightened by repainting in attractive and appropriate colors—which are no more expensive to apply than are uninspiring, inappropriate colors. Color-preference surveys in military dining facilities have indicated that generally blue schemes (with blue, green, and yellow accent) are most preferred; a green scheme (composed of two shades of green and a yellow accent) is also popular. While it is difficult to make specific recommendations based on such results, the most important consideration in the application of color is that a coordinated, pleasing combination be used. Generally these may be determined by locale and geographic conditions (e.g., cool colors in warm climates). In any case, special attention should be given to the selection and application of color schemes as a means of improving overall decor.

Serving and Layout Functions. Functional considerations are also of fundamental importance in planning decor improvements. A poor layout, for example, will limit a designer in planning for acoustical and visual improvements, interrupt privacy, or impose unnecessary noise. A proper layout should consider:

1. A good location and adequate space for all key stations or functions (coatroom, check-in, serving line, beverages and salad bar, short order line, collecting dishes and silverware, etc.)
2. Efficient circulation paths.
3. Comfortable and personal seating arrangements.

Proper layout of the coatroom is necessary to eliminate circulation congestion in and out of the dining facility. Poor layouts may require customers who are picking up coats to interrupt the line of those who are entering the facility. The use of properly laid out coat racks will avert such a pattern. A check-in desk

is best at the entry to the serving line, permitting patrons to move freely in the dining facility and permitting the checker to perform efficient identification.

Serving lines should be visually and acoustically separated from the rest of the dining area to provide a more private, uncluttered dining experience once the customer is inside and seated. Beverages, salad bar, utensils and other pickup items should be placed in a position in the serving line for efficient serving operations and should be out of the dining area to afford a pleasant, uncluttered setting.

Cleanup operations should be separated visually and acoustically from the dining area. Whenever possible, soiled-tray carts should be located near the dining facility exit, and be visually separated from the dining area.

Open circulation, or smooth movement of customers and operational personnel through the dining facility, is a basic component of a proper layout and should be carefully considered in any renovation projects. Smooth, open circulation helps alleviate the effects of crowding, cluttering, or other unpleasantness. Basic rules of good circulation are:

1. Passageways within the seating area should be a minimum of four feet wide to allow for passage of clean-up carts.
2. Major passageways should be a minimum of five feet wide.
3. Traffic should be routed as much as possible about the perimeter of the dining area.

Since dining facility customers may often react adversely to the uniform arrangement of rows of tables and chairs, seating arrangements that define smaller, more personal settings are recommended, using combinations of basic seating units. Varying the shapes and sizes of tables permits easy and variable groupings, and also lends a quality of freedom and flexibility to the military dining situation.

Sound and Noise Control. Since distracting noise is a common irritant in military dining facilities, a variety of techniques and materials may be employed for noise control:

1. Control of noise at its source,
2. Reduction of noise transmission
3. Control at the listeners' location through absorption.

Much kitchen noise comes from the clatter of dishes, silver, trays, pots and pans. Voice noise levels will decrease when it no longer becomes necessary to speak over such operational clatter.

Much noise leakage occurs from the outside—or from the kitchen to the dining area—through pass-through doors, serving windows, and dish return hatches. Shielding a dining area from kitchen noise may be accomplished through a combination of barriers and absorptive materials. A floor-to-ceiling barrier between the serving line and the dining area may serve to reflect much of the noise when the food-serving line is supplied through a serving window from the kitchen. Upper walls and ceiling may be fully treated with absorptive material to help control the noise. Since lower walls and floor are vulnerable to spillage, membrane-protected material may be used. Barriers used may be

APPENDIX A

standard partitions; however, if visibility is desired, two sheets of ¼-inch glass, separated by a 2-inch air space, may be used.

Noise produced within the dining area itself may be controlled through use of the following absorptive materials: absorbing tile or panels, portable partitions, suspended ceilings of acoustic tile, draperies, and carpet. The principle of noise control involves breaking up the area of a large room with tall partitions for full-length divider draperies. If partitions are installed with absorptive materials on one or both sides, then noise control will be improved for the entire room.

Background music serves to mask unavoidable noises and provides privacy by muting conversation at distances of more than a few feet. Volume level over the room should be uniform; however, a slightly higher level near the kitchen and serving-line area will mask major noise leakage from these areas. A number of ceiling-mounted speakers generally should be uniformly spaced and separated from each other by twice the distance from table tops to ceiling to insure the most efficient noise masking.

The following information is provided to assist dining facility managers in the proper maintenance of materials listed in this guide. Comments and suggestions concerning maintenance are invited and will be considered for inclusion in future guide revisions.

Carpet Maintenance. Carpet maintenance should be in accordance with the manufacturer's instructions. A carpet should be vacuumed a minimum of once a day with a heavy-duty, industrial-type vacuum cleaner which has a brush and beater bar. It may be necessary to vacuum following each meal, and a thorough vacuuming should precede any shampooing operation.

Carpet should be inspected frequently to insure that spots, stains, and loose strands or threads are removed. Loose strands or threads should be cut to avoid further damage. Liquids or spills should be blotted immediately with a cloth, paper towel, or clean sponge. To treat stains, first identify the stain in order to select the proper stain remover, and then begin at the outer edge and work toward center of stained area. Do not rub or brush the spot more than necessary. Coffee, soft drinks, milk, chocolate, juices, mustard, catsup, gravy and most other food spillage should be removed as soon as possible. After spot cleaning the soiled area with detergent and a minimum amount of water, blot the area dry with tissues or towels.

For asphalt, chewing gum, grease, oil, wax, etc., remove as much of the substance as possible before applying a small amount of volatile solvent or dry cleaning fluid to the spot. Remove the dissolved stain by blotting with absorbent tissues—do not rub. Repeat as necessary.

Once the stain is removed, drying the area rapidly with a fan or weighted tissues will minimize the chance of saturating or permanently staining the backing material. Commercial spot removal kits are available and a local carpet dealer can assist in selecting a kit for a particular type of carpet. (WARNING: Always test a new solvent or cleaning substance in a remote corner to insure that it does not adversely affect the dye or the fiber.)

Surface cleaning should be scheduled as often as necessary, depending on the extent of soiling. The use of mats will help control soiling near entrances, but the areas near the entrance and serving lines will require more frequent surface cleaning. The two recommended methods of removing this visible soil are:

1. Biodegradable, synthetic detergent shampoos containing dry cleaning solvents used in a foam type non-electric applicator. The applicator is filled according to manufacturer's directions with diluted shampoo and used in the same push-pull manner as a non-electric carpet sweeper.

2. Mop-on products applied with a sponge mop or short-clipped, cotton mop. The operator should mop the carpet as he would damp-mop a hard floor. Excess cleaning solution should be thoroughly squeezed from the mop to avoid overwetting the carpet. A variation of this method is to spray the cleaning agent directly onto the carpet with an aerosol spray and agitate the foam with a bristle brush or sponge mop dipped into water.

These methods remove surface soil only and should be supplemented with

APPENDIX B

machine shampooing to loosen and remove imbedded soil. The frequency of deep cleaning will depend on the extent of soiling. Too frequent cleaning will contribute to accelerated wear. The recommended equipment is a reel-type foam shampooer with built-in wet suction pick-up (sample item described below). If the foam shampooer is not equipped with a wet suction pick-up, the dirty foam should be removed by a separate wet suction pick-up vacuum within 2-3 minutes. The significant advantages of the foam-type shampooer over the wet rotary system are that it is fast drying and does not over-wet or shrink the carpet. Wet rotary shampooing is appropriate for heavily soiled carpets. Rotary machines may also be equipped with foam dispensing attachments which reduce drying time and eliminate the over-wetting shrinkage possibilities. The exact amount of water and detergent used will depend upon the operator's judgment—excessive moisture and excessive detergent should be avoided. Wet vacuuming should immediately follow both wet and foam shampooing if the shampooer does not include a vacuum pickup. Immediately after wet vacuuming, the carpet should be brushed uniformly with a pile-setting brush to even out the pile and eliminate marks from the shampooer. The carpet should be forced-dried and then vacuumed. It should not be subjected to normal use until completely dry. Wear or soil paths on the carpet can be avoided by periodic rearrangement of partitions and tables.

Vinyl and Quarry Tile Maintenance. Vinyl and quarry tile can be kept clean and sanitary by washing with ordinary soap and warm water. A soapless detergent is recommended for hard-water locales. Soap and water should be applied with a brush or mop and allowed to remain on the tile for a few minutes before rinsing.

Drapery Maintenance. To insure proper handling of the various types of fabrics, it is recommended that drapery cleaning be performed only by a professional cleaning establishment. For best maintenance results we recommend the following technical specifications for Verel fabrics:

Dry Cleaning— Use a 2-5 minute cycle—low moisture—extract lightly. Tumble dry for 10-20 minutes at temperature not to exceed 103 F. Fabrics will restore best with air drying.

Pressing Instructions—

Hand Iron— Low heat setting (275 F) with damp press cloth.

Steam Iron— Use dry press cloth.

Grid Head Press— Press for short intervals with minimum steam. **DO NOT LOCK HEAD.**

Flat Bed Press— Press dampened drapery using cloth covering.

- ACADEMY ARTS, 1840 N. Clybourn Ave., Chicago, IL 60614, (312) 943-8900
- ACOUSTICAL SCREENS IN COLOR, INC., 3600 Executive Blvd., Mesquite, TX 75149, (214) 288-5401
- A. BRANDT CO., INC., P.O. Box 391, Fort Worth, TX 76101, (817) 926-5141 (Home Office)
- BIGELOW-SANFORD, INC., 4818 MacArthur Blvd. N.W., Washington, D.C. 20007, (202) 338-2951
- B. BRODY SEATING CO., 5921 W. Dickens Avenue, Chicago, IL 60639, (312) 889-6000 (Home Office)
- BULLETIN BOARDS AND DIRECTORY PRODUCTS, INC., 724 Broadway, New York, NY 10003, (212) 777-1244, 777-1245 (Home Office)
- CHARLOTTE CHAIR CO., Charlotte, MI 48813, (517) 543-4210 (Home Office)
- CORAL OF CHICAGO, 2001 S. Calumet, Chicago, IL 60616, (312) 225-5800
- DWOSKIN INC. (GENON), 2170 Piedmont Road, NE, Atlanta, GA 30324, (404) 875-3511 (Home Office)
- FALCON PRODUCTS, INC., 9387 Dielman Industrial Drive, St. Louis, MO 63132, (314) 997-5600 (Home Office)
- FELDMAN LIGHTING, 612 South Wall Street, Los Angeles, CA 90014, (213) 627-6731 (Home Office)
- FIXTURES MANUFACTURING CORP, 1641 Crystal, Kansas City, MO 64126, (816) 241-4500 (Home Office)
- FLINTKOTE CO., 480 Central Ave., East Rutherford, NJ 07073
- GENON, The General Tire and Rubber Co., Chemical-Plastics Division, Columbus, MS 39701
- HALO LIGHTING DIVISION, MCGRAW-EDISON COMPANY, 930 W. Bryn Mawr Ave., Rosemont, IL 60018, (312) 678-4570 (Home Office)
- HERMAN MILLER, INC., 622-624 Merchandise Mart, Chicago, IL 60654, (312) 527-5730
- INTERROYAL, One Park Ave., New York, NY 10016
- JOHNSON INDUSTRIES, 376 Summit, P.O. Box 547, Elgin, IL 60120, (312) 626-4154 (Home Office)
- KENTILE FLOORS INC., 4532 S. Kolin Ave., Chicago, IL 60632, (312) 523-6814
- KRUEGER METAL PRODUCTS CO., 1056 W. Mason Street, Green Bay, WI 54306, (414) 437-3245 (Home Office)

APPENDIX C**MANUFACTURERS**

- K-S-H, INC., 10091 Manchester Road, St. Louis, MO 63122, (314) 966-3111
(Home Office)
- LEE'S CARPET, Valley Forge Corporate Center, King of Prussia, PA 19406,
(312) 337-3193
- MADISON FURNITURE IND., P.O. Drawer 111, Canton, MS 39046, (601)
859-3771 (Home Office)
- MIDWESTERN DISTRIBUTION CENTER, 4607 W. Lexington, Chicago, IL 60654
(312) 287-3600 (Home Office)
- MONARCH CARPET, 5025 New Peachtree Road, Chamblee, GA 30341, (312)
467-1550 (District Office)
- PAYNE AND COMPANY, S. J. Campbell Company, Space 6-171, Merchandise
Mart, Chicago, IL 60654, (312) 467-1450
- SGI, 609 W. Lake Street, Chicago, IL 60654, (312) 372-3805 (Home Office)
- SHELBY WILLIAMS INDUSTRIES, INC., 325 N. Wells, Chicago, IL 60610, (312)
527-3500 (Home Office)
- SOUNDOLIER, INC., 9380 Watson Industrial Park, St. Louis, MO 63114, (314)
962-9870 (Home Office)
- 3M BUSINESS PRODUCTS SALES, INC., Chicago—Bedford Park & So. Harlem
Avenue. For federal government business: 1750 Pennsylvania Avenue N.W.,
Washington, D.C. 20026
- THOMAS INDUSTRIES, 207 E. Broadway, Louisville, KY 40202, (502) 582-3771
(Home Office)
- TURNER MFG. CO., 2309 S. Keeler Ave., Chicago, IL 60623, (312) 277-8800
(Home Office)
- VICRTEX, L. E. Carpenter & Co., 170 N. Main Street, Wharton, NJ 07885, (201)
366-2020 (Home Office)
- YORKRAFT CONTRACT, 550 S. Pine Street, York, PA 17405, (717) 845-3666

- Berkeley, Bernard, *Floors and Floor Maintenance*, American Hotel & Motel Association, The Cornell Hotel & Restaurant Administration Quarterly School of Hotel Administration, Cornell University, Ithaca, N.Y., 1967.
- Berkeley, Bernard, *The Selection and Maintenance of Commercial Carpet*, American Hotel & Motel Association, The Cornell Hotel & Restaurant Administration Quarterly, School of Hotel Administration, Cornell University, Ithaca, N.Y., 1970.
- Birren, Faber, *Color for Interiors: Historical and Modern* (Whitney Library of Design, New York, 1962).
- Birren, Faber, *Light, Color and Environment* (Van Nostrand Reinhold Co., New York, 1969).
- Corlin, Len (ed.), "Weigh All Carpet Variables to Make Specification Work," *Contract* (June 1972), pp 59-61.
- Corlin, Len (ed.), "Direct Glue-Down Carpet Trend Developing," *Contract* (June 1972), pp 77-80.
- Department of Defense Construction Criteria Manual*, DOD 4270.1-M (Office of the Assistant Secretary of Defense [Installations and Logistics], March 1, 1968).
- Department of the Army Technical Manuals:
TM 5-805-1 *Acoustical Treatments*
TM 5-810-1 *Mechanical Design: Heating, Ventilating, and Air Conditioning*
TM 5-812-1 *Fire Prevention*.
- Fengler, Max, *Restaurant Architecture and Design: An International Survey of Eating Places* (Universe Books, New York, 1971).
- Foxhall, William B., "Design Elements of Food Services for Colleges and Universities," *Architectural Record* (April 1962), pp 184-185.
- Gibbs, Wes and Cramer, R., *Dining Facility User-Attitudes and Environmental Design Research at Travis AFB, California*, CERL Preliminary Report D-5 (June 1973).
- Gibbs, Wes, *Comparison of Consumer-Satisfaction Before and After Dining Facility Renovations at Travis AFB, California*, CERL Technical Report D-28 (August 1974).
- Gibbs, Wes, *Comparative Study of Consumer Attitudes at Three Air Force Dining Facilities*, CERL Interim Report D-40 (September 1974).
- Gibbs, Wes, *The Dining Facility Decor Experiment at Fort Lee, VA*, CERL Letter Report D-42 (October 1972).

- Gibbs, Wes, *Dining Facility Evaluation and Improvement Guide*, CERL Technical Report D-34 (September 1974).
- Halse, Albert O., *The Use of Color in Interiors* (McGraw-Hill, Inc., 1968).
- Judd, Deane B., "A Flattery Index for Artificial Illuminants," *Illuminating Engineering*, Vol 62, No. 10 (October 1967), pp 593-598.
- Kinzey, Bertram Y., Jr. and Sharp, Howard M., *Environmental Technologies in Architecture* (Prentice-Hall, Inc., Englewood Cliffs, N.J., 1963).
- Kotschevar, Lendal H. and Terrell, Margaret E., *Food Service Layout and Equipment Planning* (John Wiley & Sons, Inc., New York, 1961).
- Kryter, Karl, *The Effects of Noise on Man* (Academic Press, New York, 1970).
- Kukoy, Linda, "Space Planning and Design," *Institutions Magazine* (August 1968), pp 103-108.
- Little, R. Keith, *Kitchen Layout Logic*, John F. Virgin, ed. (Age Publications, Ltd., Toronto, 1959).
- Manual on Sanitation Aspects of Installation of Food Service Equipment* (NSF Advisory Committee on Installation of Food Equipment and the NSF Joint Committee on Food Equipment Standards, National Sanitation Foundation, Ann Arbor, Michigan, 1968).
- Newman, Robert B. and Cavanaugh, William J., "Sound Systems," *Architectural Record* (December 1961-January 1962).
- Phillips, Derek, *Lighting in Architectural Design* (McGraw-Hill, Inc., New York, 1964).
- Ramsey, Charles J. and Slepper, Harold R., *Architectural Graphic Standards*, 6th edition, Joseph N. Boaz, ed. (John Wiley & Sons, Inc., New York, 1970).
- Roberts, H. C., "Quiet Please! What M/E Engineers Need to Know About Noise Control," *Actual Specifying Engineer* (May 1970), pp 96-99 (July 1970), pp 92-96 (September 1970), pp 88-93.
- Schmidt, John L., Lewis, Walter H. and Olin, Harold Bennett, *Construction: Principles, Materials & Methods* (American Savings and Loan Institute Press, Chicago, and Interstate Printers and Publishers, Inc., Danville, Illinois, 1970).
- Soda Fountain and Luncheonette Equipment* (Joint Committee on Food Equipment Standards, National Sanitation Foundation, Ann Arbor, Michigan, 1969).

APPENDIX C

REFERENCES

Stokes, John W., *Food Service in Industry and Institution* (William C. Brown Co., Dubuque, Iowa, 1960).

United States Public Health Service Food Service Sanitation Ordinance and Code (U.S. Department of Health, Education and Welfare).

DISTRIBUTION

USARSO

Fort Clayton (8)

USARAL

US Army Alaska/ARAGL-SF (7)

USASA

Vint Hill Farms
313th ASA Bn/ABN Corps
Arlington Hall Station
7th RRFS
Field Station Augsburg
Field Station Berlin

MDW

Fort Lesley J. McNair
ATTN: Facilities Engr
ATTN: ANLOG-C
Fort Myer
HQDA/SAAS-IL, Wash DC

USAONE

Fort Belvoir
ATTN: ATZA-DI
ATTN: ATZA-FE
ATTN: ATZA-DI-SVF
Fort Benning
ATTN: ATZB-FE-EP
ATTN: ATZB-DI-POO
ATTN: ATZB-DI-C
Fort Buchanan
ATTN: AJESA
ATTN: AJEFE
Fort Campbell
ATTN: AJCGD
ATTN: AJCSV
ATTN: AJCEN
ATTN: AJSDDL-SV
Fort Devens
ATTN: AFZD-FE
ATTN: AFZD-DI-F
ATTN: AFZD-DI-SV
Fort Dix
ATTN: AHBOGD
ATTN: AHBOEN
ATTN: AHBOSV-F
Fort Bragg
ATTN: AJBDIO
ATTN: AJBFE
ATTN: AJBSV-FS
ATTN: Svcs Div, AC of S, G-4
ATTN: Div, Food Svc Advisor
ATTN: Food Svc Advisor, Kennedy
Center
ATTN: Food Svc Advisor, 1st COSCOM
ATTN: Food Svc Advisor, Institute
for Mil. Assis.
Fort Drum
ATTN: AHBIBD
ATTN: AHBIEN
ATTN: AHBID-S
Fort Eustis
ATTN: AHBE-DE
ATTN: AHBE-DO
ATTN: AHBE-SV
Fort Gordon
ATTN: ATZHDI
ATTN: ATZHFE-A
ATTN: ATZHDI-SV
Fort Hamilton
ATTN: AFZE-DI
ATTN: AFZE-FE
ATTN: AFZE-DI-SE-FS
IGMR
ATTN: AHBDD
ATTN: AHBDR
ATTN: AHBID-S
Fort Stewart
Fort Jackson
ATTN: AJJGL
ATTN: AJJEN
ATTN: AJGL-V
Fort Knox
ATTN: ATZK-DI-SV
ATTN: ATZK-FE
ATTN: ATZK-DI-SV-F
Fort Lee
ATTN: ATZM-DI
ATTN: ATZM-FE
ATTN: ATZM-FM
ATTN: ATZM-TEX-SF
Fort McPherson
ATTN: AJXDI
ATTN: AJXFE
ATTN: AJXDI-S
ATTN: DFAE
ATTN: Sup Div, DIO
ATTN: Installation Fd Svc Adv

USAONE (cont'd)

Fort Meade
ATTN: AHBMD
ATTN: AHBMD-SVG
ATTN: AHBME
ATTN: Sup Div, DIO
ATTN: Food Svc Advisor
ATTN: DFAE
Fort McClellan
ATTN: AJMCS-L
ATTN: AJMFE
ATTN: AJMCS-L
Fort Monroe
ATTN: ATZGFE
ATTN: ATZGDI
ATTN: ATZGDI-FS
ATTN: Sup Div, DIO
ATTN: Food Svc Advisor
ATTN: DFAE
Fort Polk
ATTN: ATZP-DI
ATTN: ATZP-FE
ATTN: ATZP-DI-SV-F
Fort Rucker
ATTN: AJRDFE
ATTN: AJRDIO
ATTN: AJRDIO-SV
Fort Stewart
ATTN: Commander
Fort Story
ATTN: AHBE-DO-S
ATTN: AHBE-DE-S
ATTN: AHBE-SV-S
USAFIVE
Fort Bliss
ATTN: ALBCD
ATTN: ALBCF
ATTN: ALBCDR-F
Fort Benjamin Harrison
ATTN: ATZI-DI-S
ATTN: ATZI-FE
ATTN: ATZI-HD
Fort Hood
ATTN: AFZF-BDIO
ATTN: AFZF-BDFE
ATTN: ATZF-BSVC-S
ATTN: Sup Div, AC of S, G-4
ATTN: Div Food Svc Advisor
ATTN: Sup Div, AC of S, G-4 (Tricap)
ATTN: Div Food Svc Advisor (Tricap)
Fort Sam Houston
ATTN: ALBKDI-SR
ATTN: ALBKDE
ATTN: ALBXDI-SRF
ATTN: DFAE
ATTN: Sup Div, DIO
ATTN: Installation Food Svc Advisor
Camp McCoy
ATTN: AFZR-DI
ATTN: AFZR-FE
ATTN: AFZR-DI-FS
Fort Sill
ATTN: ALBC-ND
ATTN: ALBCG
ATTN: ALBGD
ATTN: ALBGD-SS-F
ATTN: ATSFA-OL
Fort Leonard Wood
ATTN: ALBHIN
ATTN: ALBHIN-QFS
Fort Sheridan
ATTN: AFZODI
ATTN: AFZOFE
ATTN: AFZOHC-D

USASIX

Fort Carson
ATTN: AFZC-FE
ATTN: AFZC-DI
ATTN: AFZC-DI-QF
Fort Huachuca
ATTN: SCCH-FE
ATTN: SCCH-IOD-S
Fort Leavenworth
ATTN: ALBDIO
ATTN: ALBDFE
ATTN: ALBDFE-F
Fort Lewis
ATTN: AMNLE-DIO
ATTN: AMNLE-DFAE
ATTN: AMNLE-DIO-FS
Fort MacArthur
ATTN: AFZJ-DI

USASIX (cont'd)

Fort Ord
ATTN: AMNOR-D
ATTN: AMNOR-F
ATTN: AMNOR-SVF
Presidio of San Francisco
ATTN: AMPR-DIO
ATTN: AMPR-DFAE
ATTN: AMNPR-SVC
Oakland Army Base
ATTN: AMPCO-LSD
Fort Riley
ATTN: ALBFDL
ATTN: ALBFFE
ATTN: ALBFDL-VS
USAMC
Alexandria, VA
ATTN: AMCIS-S
Rock Island Arsenal
ATTN: AMCIS-RI-SB
ATTN: US Army Armaments Command
Fort Monmouth
ATTN: AMSEL-IS-SV
ATTN: Commander
Redstone Arsenal
ATTN: AMSMI-KH
ATTN: Commander
Natick Laboratories
ATTN: AMXRE-PRBA
ATTN: AMXRE-PRBH
ATTN: AMXRES-F
ATTN: AMXRES-O
Technical Library
Dugway Proving Ground
ATTN: Desert Testing Center
Aberdeen Proving Ground
ATTN: Commander
ATTN: AMSTE-LG-S
Rocky Mountain Arsenal
ATTN: Commander
Sacramento Army Depot
ATTN: Commander
Savanna Army Depot
ATTN: Commander
Seneca Army Depot
ATTN: Commander
Sharpe Army Depot
ATTN: Commander
Sierra Army Depot
ATTN: Commander
White Sands Missile Range
ATTN: Commander
Yuma Proving Grounds
ATTN: Commander
USAREUR
US Forces Sup Dist/Commander
Baden-Wuerttemberg
Hessen
Nord Bayern
Sued Bayern
Rheinland-Pfalz
Norddeutschland
15th MP Bde
1st Spt Bde
59th Ord Gp
60th Ord Gp
USATRANSCOMEUR
USAMEDCOMEUR
USACEGEEUR
V Corps/Food Advisor
3rd Arm'd Div (3)
8th Infantry Div (3)
130th Engineer Bde
V Corps Artillery
11th ACR
VII Corps/Food Advisor
1st Infantry Div (3)
1st Armored Div (3)
3rd Infantry Div (3)
2nd ACR
7th Engineer Bde
VII Corps Artillery
US Army, Europe & 7th Army
ATTN: AEAGD-SV-F (2)
ATTN: AEAEN (2)
1st Support Brigade (2)
US Army Berlin/Food Advisor
Army South Eastern Task Force
ATTN: Food Advisor
32D Army Air Defense Command
ATTN: Food Advisor
US Army Engineer Command Europe
ATTN: Log Dir
124th Engr GP
7th Army Training Center

USAREUR (cont'd)

USAREUR CSTC
56th Field Arty Bde
7th Signal Brigade
15th Aviation Group
66th Military Intelligence Group
V Corps Support Command
2D Support Command

USAHSC

Commander

AMC

Phoenixville PA
Fitzsimons
Brooke
Walter Reed
Fort Gordon
Letterman
William Beaumont
Madigan

MEDDAC

Fort Sheridan
Fort Benjamin Harrison
Fort Knox
Carlisle Bks
Fort Devens
Fort Monmouth
West Point
Fort Lee
Fort Belvoir
Fort Detrick

ATTN: HSCD-L

ARADCOM

Commander

Ent Air Force Base, CO
31st ADA Brigade

TSG

Commander

MEDDAC

Fort Meade
Fort Dix
Edgewood Arsenal
Fort Monroe
Fort Eustis
Fort Campbell
Fort McClellan
Fort Rucker
Fort McPherson
Fort Benning
Fort Bragg
Fort Jackson
Fort Stewart
Redstone Arsenal
Fort Sill
Fort Hood
Fort Polk
Dugway Proving Ground
Fort Carson
Fort Leonard Wood
Fort Riley
Fort Huachuca
Fort Leavenworth
Yuma Proving Ground
Sierra Army Depot
Fort Ord
Fort MacArthur
Army Medical Specialist Corps
ATTN: DASG-DB
Logistics and Facilities Division
ATTN: DASG-HCL
Fort Sam Houston
ATTN: HSC-LO
William Beaumont Army Medical Center

USARPAC

Commander

Eighth USA/EAGL-SV-F (2)
2d Infantry Div/EAID-DSO-FS (3)
38th Artillery Brigade/EAAD-LO
4th US Army Missile Command /EAFM-S4
19th Support Group/EANG-S4
US Army Support Command, Hawaii/HCLOG-I
25th Infantry Div/G-4
US Army Base Command, Okinawa/BCOSUBS-FS
US Army, Japan /GD-T
US Army Fac Engr Acty, Kanto Plain/ENKP
USARSUPTHAI/THAD-F
USARSUPTHAI/THEO
Facilities Engr, Southern Area
US Army Engr Div, Pacific Ocean/Library
US Army Garrison, Okinawa/BCOG
US Army Sup Command, Hawaii/HCFE
Facilities Engineer, Northern Area
EUSA/USFK/UNC
ATTN: EAGL-SV-F

USARPAC (cont'd)

2d Wngr Group/EAEG
2d Transportation Group/EATC
4th Signal Group/FSCP
502d MI Bn/MIB
728th MP Bn/EAMP
USA Medical Dept Activity, Korea/EAMC
Hq Comd, EUSA/EACO
US Army Support Group, JSA/EAJJS
USAPDK/EAPD
USAIMC/EAIM
I Corps ROK/US Group/AC of S, G-4
51st Signal BN/Food Svc Advisor
23rd Support Group/ACLOG-I
25th S & T BN/Food Service
USAIMC/EAIM
USACDC Engineering Agency
Kwajelein Missile Range/SSC-RKL

MTMTS

WAMTMTS ATTN: MTW-BCFE
EAMTMTS ATTN: MTE-SUF
MOT ATTN: MTE-BY-FED
MOT, Sunny Point ATTN: MTE-SU

National Technical Information Service (5)

Ft Monroe

TRADOC/Commander

Fort McPherson

FORSOCM

ATTN: Commander

ATTN: Buildings and Grounds Br.

Director

Army-Air Force Exchange Service

Hdqts

ATTN: ENA

Dallas, TX

USASFSCOM

Commander

Kwajelein Missile Range/SSC-RKL

504 ASA GP (2)

Grand Forks/SSC-SF-G

USACC

Commander

USACC-Europe

USACC-Pacific

USACC-CONUS

Fort Huachuca

CARLISLE BARRACKS

Commander

AHBGE

AHBGD

Food Advisor

GSA

Atlanta GA

Auburn WA

Boston MA

Chicago IL

Denver CO

Fort Worth TX

Kansas City MO

New York NY

San Francisco CA

Washington DC

Fort Meade

National Technical Info Serv

Chief of Engineers

ATTN: DAEN-ZS

ATTN: DAEN-RD

ATTN: DAEN-MCZ-S

ATTN: DAEN-MEZ-S

ATTN: DAEN-MCE-A

ATTN: DAEN-MCC-E

ATTN: DAEN-MCF

ATTN: DAEN-ASI-L

ATTN: DAEN-PA

Department of the Army

WASH DC 20314

DCSLOG

ATTN: DALO-SMT

Department of the Army

WASH DC 20310

The Adjutant General

ATTN: The Army Library

Department of the Army

WASH DC 20310

C, DOD Food Service Fac & Equip Planning Bd

Office of the Chief of Engineers, DA

ATTN: DAEN-MCE-A (2)

WASH DC 20314

Chief of Naval Operations
ATTN: Library
Department of the Navy
WASH DC 20360

Navy Facilities Engineering Command
ATTN: Chief Engineer
Department of the Navy
WASH DC 20350

Chief of Staff
ATTN: Library
Department of the Air Force
WASH DC 20330

Director of Civil Engineering
Department of the Air Force
WASH DC 20330

Director
USAWES
P. O. Box 631
Vicksburg MS 39181

Commander
USACDC Engineer Agency
Fort Belvoir VA 22060

Naval Civil Engineering Laboratory
Technical Library
CODE: L31
Fort Hueneme CA 93043

US General Services Administration
Federal Supply Service
ATTN: Interior Design and Planning Staff
ATTN: National Buying Center
WASH DC 20406

US Army Corps of Engineers, New England Div, MA
US Army Corps of Engineers, North Atlantic Div, NY
US Army Engineer District, NY
US Army Engineer District, Baltimore
US Army Corps of Engineers, South Atlantic Div, GA
US Army Engineer District, Savanna
US Army Engineer District, Mobile
US Army Corps of Engineers, Ohio River Div, OH
US Army Corps of Engineers, Missouri River Div
US Army Engineer District, Omaha
US Army Corps of Engineers, North Central Div, IL
US Army Engineer District, Chicago
US Army Corps of Engineers, South Western Div, TX
US Army Engineer District, Fort Worth
US Army Corps of Engineers, South Pacific Div, CA
US Army Engineer District, Sacramento
US Army Engineer District, Los Angeles
US Army Corps of Engineers, North Pacific Div, OR
US Army Engineer District, Alaska
US Army Corps of Engineers, Pacific Ocean Div, HI
US Army Engineers District, Japan
US Army Engineers District, Far East
US Army Corps of Engineers, Mediterranean Div, APO NY 09019
US Army Engineers District, Saudi Arabia
Superintendent of Documents
Div of Public Documents
US Government Printing Office
WASH DC 20402

Library of Congress
Exchange and Gift Division
ATTN: American and British
WASH DC 20540

Commander
US Army Natick Laboratories
ATTN: AMXRE-PRBA
ATTN: AMRE-PRBH
ATTN: AMXRES-F
ATTN: AMXRES-O
ATTN: Technical Library
Natick, MA 01760

Commander
US Navy Subsistence Office
Bldg 166
Navy Yard Annex
WASH DC 20390
Commander
Naval Facilities Engineering Command
Y-D Annex
Room 2-C-370
WASH DC 20390

Commander
US Air Forces Service Office
ATTN: DPKFF
2800 South 20th Street
Philadelphia PA 19101

Directorate for Subs. Mgmt, Policy
Office Ass't Sec of Def (I&L)
ATTN: LTC J. L. Welbourn
The Pentagon, Room 2B 323
WASH DC 20310

HQDA (DALO-TSS)
WASH DC 20301

Commander
Defense General Supply Center
CODE: DGSC/TSA
Defense Supply Agency
Richmond VA 23219

Commander
Hq, US Air Force
ATTN: AFPREED
Bldg 626, Room 269
Bolling AFB
WASH DC 20330

Commander
HQ, US Marine Corps
CODE: COE-2
WASH DC 20380

Commander, 3rd USA
ATTN: Engineer
Fort McPherson GA 30330

Commander, 5th USA
ATTN: Engineer
Fort Sam Houston TX 78234

Commander, 6th USA
ATTN: Engineer
Presidio of San Francisco CA 94129

Commander
USAES
ATTN: Library
Fort Belvoir VA 22060

Director
USACRREL
P.O. Box 282
Hanover NH 03755