

AD-A075 427

MASSACHUSETTS INST OF TECH CAMBRIDGE ARCHITECTURE MA--ETC F/G 5/8  
GRAPHICAL INPUT TECHNIQUES.(U)  
SEP 79 A LIPPMAN , N NEGROPONTE

DAHC19-78-G-0008

UNCLASSIFIED

ARI-TR-409

NL

| OF |  
ADA  
075427



END  
DATE  
FILMED  
11 -79  
DDC

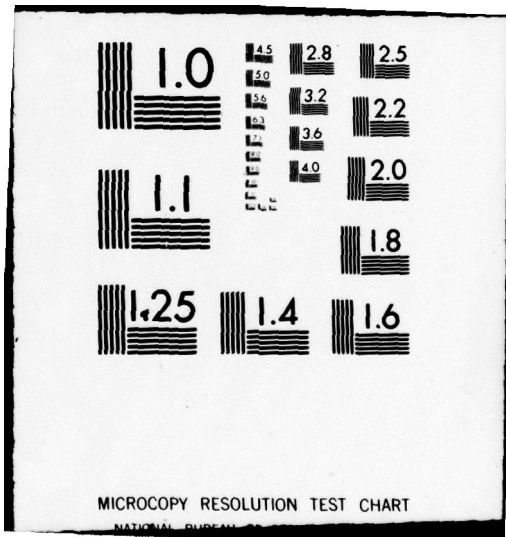

MICROCOPY RESOLUTION TEST CHART

NATIONAL BUREAU OF STANDARDS-1963-A

Technical Report 409

LEVEL IV

AD A 0 7 5 4 2 7

# GRAPHICAL INPUT TECHNIQUES

Andrew Lippman and Nicholas Negroponte  
Massachusetts Institute of Technology

DDC  
RECEIVED  
OCT 24 1979  
E

BASIC RESEARCH

DDC FILE COPY

ORIGINAL CONTAINS COLOR PLATES: ALL DDC  
REPRODUCTIONS WILL BE IN BLACK AND WHITE.



U. S. Army

Research Institute for the Behavioral and Social Sciences

September 1979

Approved for public release; distribution unlimited.

79 22 22 116

**U. S. ARMY RESEARCH INSTITUTE  
FOR THE BEHAVIORAL AND SOCIAL SCIENCES**

**A Field Operating Agency under the Jurisdiction of the  
Deputy Chief of Staff for Personnel**

**JOSEPH ZEIDNER  
Technical Director**

**WILLIAM L. HAUSER  
Colonel, U S Army  
Commander**

---

Research accomplished for the  
Department of the Army

Architecture Machine Group  
Massachusetts Institute of Technology

**NOTICES**

**DISTRIBUTION:** Primary distribution of this report has been made by ARI. Please address correspondence concerning distribution of reports to: U. S. Army Research Institute for the Behavioral and Social Sciences, ATTN: PERI-P, 5001 Eisenhower Avenue, Alexandria, Virginia 22333.

**FINAL DISPOSITION:** This report may be destroyed when it is no longer needed. Please do not return it to the U. S. Army Research Institute for the Behavioral and Social Sciences.

**NOTE:** The findings in this report are not to be construed as an official Department of the Army position, unless so designated by other authorized documents.



20. (Continued)  
data and imagery, and annotation programs where rapid data entry from hard  
copy is required.

Accession For	
NTIS GRA&I	
DDC TAB	
Unannounced	
Justification	
By	
Distribution/	
Availability Codes	
Dist	Availand/or special

**Technical Report 409**

# **GRAPHICAL INPUT TECHNIQUES**

**Andrew Lippman and Nicholas Negroponte  
Massachusetts Institute of Technology**

**Submitted by:  
Robert M. Sasmor, Director  
BASIC RESEARCH**

**Monitored by:  
Franklin L. Moses  
Research Psychologist**

**Approved by:  
Joseph Zeidner  
Technical Director**

**U.S. ARMY RESEARCH INSTITUTE FOR THE BEHAVIORAL AND SOCIAL SCIENCES  
5001 Eisenhower Avenue, Alexandria, Virginia 22333**

**Office, Deputy Chief of Staff for Personnel  
Department of the Army**

**September 1979**

---

**Army Project Number  
2Q181102B74F**

**Basic Research**

**Approved for public release; distribution unlimited.**

ARI Research Reports and Technical Reports are intended for sponsors of R&D tasks and for other research and military agencies. Any findings ready for implementation at the time of publication are presented in the last part of the Brief. Upon completion of a major phase of the task, formal recommendations for official action normally are conveyed to appropriate military agencies by briefing or Disposition Form.

---

## FOREWORD

The Human Factors Technical Area of the Army Research Institute is concerned with improving user-computer systems to acquire, transmit, process, disseminate, and utilize information from the increasingly complex battlefield. The research is focused on the interface problems and interactions within command and control centers and is concerned with such areas as topographic products and procedures, tactical symbology, user-oriented systems, information management, staff operations and procedures, and sensor systems integration and utilization.

One area of special research interest is the design of effective and efficient on-line interaction between the operator/user and the computer. Research is focused on enhancing computer-based query languages and associated features of tactical data input, retrieval, and analysis. This publication explores interactive graphic techniques which allow the user to directly interact with the display. The techniques allow even a computer-naive person to manipulate displayed information easily. The effort is part of the exploration of improved ways for the user and computer to communicate and provides a necessary technological base for effective design of the interface.

Research in the area of concepts for man-computer synergism is conducted as an in-house effort augmented by contracts with organizations selected for their specialized capabilities and facilities. The efforts are responsive to general requirements of Army Project 2Q162722A765 and to special requirements of the U.S. Army Combined Arms Combat Development Activity, Fort Leavenworth, Kans. This specific effort was conducted under Army Project 2Q161102B74F as basic research responding to the above requirements, and was done by the Architecture Machine Group of the Massachusetts Institute of Technology.

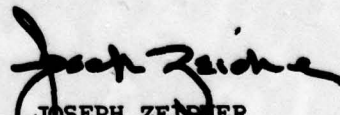
  
JOSEPH ZEINER  
Technical Director

Graphical Input Techniques - August 31, 1979

ABSTRACT.....ii

1.0 INTRODUCTION.....1

2.0 TECHNICAL DETAILS.....4

    2.1 The Back Projection Screen.....6

    2.2 The Transparency Mirror.....8

    2.3 The Tablet.....9

3.0 ILLUSTRATIVE USES.....10

    3.1 Games.....10

    3.2 Annotations.....12

4.0 EVALUATIONS.....13

## ABSTRACT

A graphic work station has been created where three aspects of man-machine interaction may be tested: (1) interaction with a flat display; (2) co-planar input and output; and (3) the ability to "see through your hand" to a display below. All three are created by a suitable arrangement of mirrors to direct a projected television image to a back-projection screen which is in turn optically superimposed onto a data tablet surface via a semi-transparent mirror. Uses and benefits of the device are demonstrated by means of a set of games which simulate a situation where a user must interact with dynamically changing data and imagery, and annotation programs where rapid data entry from hard copy is required.

## 1.0 INTRODUCTION

In spite of the rapid advances in microelectronics and computational power, little has been done to enhance the human interface to these systems. Available graphic input/output procedures still lack the immediacy that is so conveniently provided by simple pencil and paper. Often, users engaged in a graphic interaction must produce input on one device, such as a digitizing tablet, and then see the results of that input on a screen which is neither close, nor in the same plane, nor capable of showing an image at the original scale. Additionally, when the viewing screen is small, it may be flat; when it is either larger or in color, the display is necessarily curved, adding to the dissimilarity of the input and the presentation. In response to such input/display problems we developed a device that duplicates some of the salient features of hard copy, non-computer oriented graphic devices--flatness, conjoint input/output nature, and color capability. One salient feature of the device is that it provides the ability for a user to "see through his or her hand" to a display underneath.

Originally inspired by a work station developed by Knowlton (1) to provide a programmable telephone operator's console, the device consists of a flat television display optically superimposed upon either a standard digitizing tablet or a high resolution touch panel. A semi-silvered mirror interposed between tablet and display provides parallax-free coincidence of the work surface with the display screen so that a hand or object on the surface does not intersect the television display's light path; thus, a transparency effect is possible. The device is illustrated in figure 1 and schematized in figure two. Its operation will be discussed in detail later.

Three separate and distinct benefits accrue from this arrangement of input and output surfaces. The first, and primary one, is the absolute lack of parallax between display screen and data tablet. Unlike stations which use a transparent tablet overlaid on a television monitor with an image up to 1/2 inch behind the tablet, this device permits the image to appear above, below, or precisely on the working surface. When a user picks a point with either his finger or a stylus, he touches that point. Accurate feedback is provided by direct presence and visual coincidence, rather than by a cursor. Additionally,

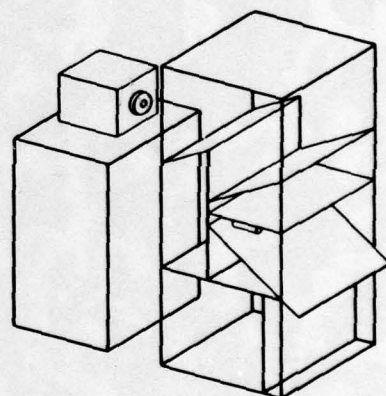
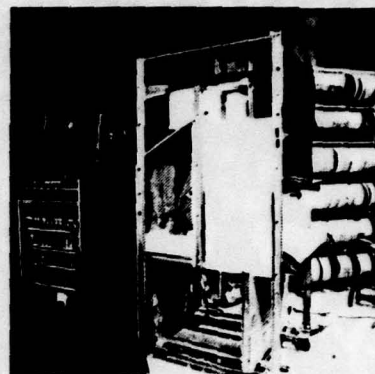

the size of the display is the same as the active tablet area, therefore a motion on one corresponds exactly to a motion on the other.

The second advantage is the creation of a flat, full color work station. Since all available direct view color monitors have either spherically or cylindrically curved front surfaces, users of color displays have accepted this curvature as an unnoticed and necessary inconvenience. When the screen is small, the resulting distortion is not great, but as the size grows, the image appears more distorted, often requiring a user to move his head to accurately view detail in the corners.

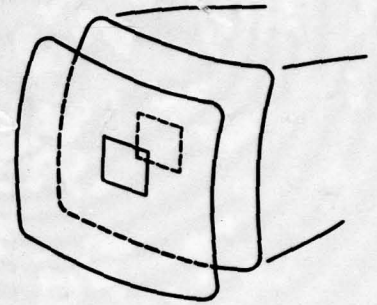

The third and least explored benefit which should be emphasized is that the user's hand does not occlude the display. In normally encountered graphical stations, the impulse to remove one's hand and inspect the result of an action is ingrained. With this device, that motion is no longer necessary. A degree of interaction with the system never possible before is now available. One may rest hands, arms and drawing aids on the work surface without interfering with the visibility of the work. In fact, the relative visibility of any of these things to the television

image is readily controllable by adjustment of the hand illumination lights: when they are bright, the hands and overlays or objects on the working surface are most clearly seen; when they are off, they totally disappear. Also, it is possible to visually mix computer output with hard copy input. In fact, this may be the best application of the device as will be explained later.

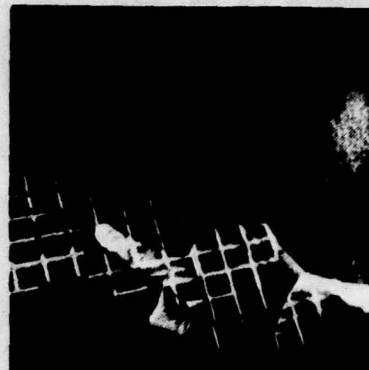

Although separate, all three features of the station work together to support each other. The feasibility of seeing through the hand reinforces the lack of parallax created by the coplanar input/output surfaces. One no longer must "look around" the hand, or pen. Likewise, the flat, similarly scaled image supplements the cursorless tablet and permits use of touch panels at full system resolution.

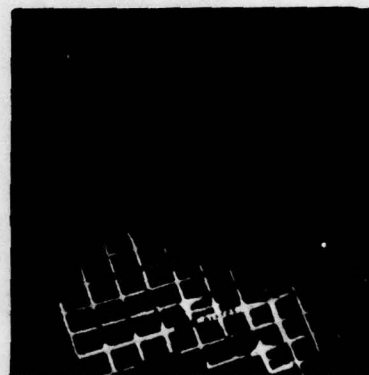

## 2.0 TECHNICAL DETAILS

With the exception of the television projector, (GE Light Valve)<sup>1</sup>, the entire apparatus of the work station is contained in a single structure. The elements of it are (1) a back projection screen on which the output image is displayed;

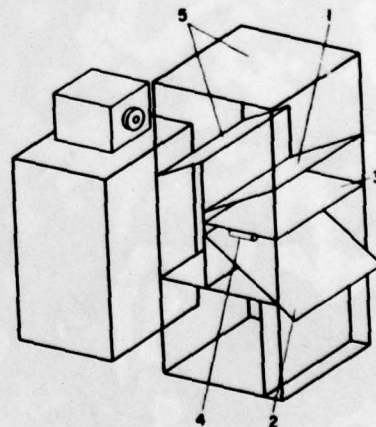

<sup>1</sup> Trade names are used only for precision in reporting and do not constitute endorsement by the Army or the U.S. Army Research Institute.

(2) a digitizing tablet, which is the work surface; (3) a superimposition mirror, which optically overlays the display image onto the tablet surface; (4) tablet illumination lights; (5) suitable directing mirrors to allow the projection display to be focused onto the back projection screen at the appropriate angle and size.

In normal use, one sits in front of the station and views both the display and the tablet from a point above the mirror. The tablet is used by placing one's hands below the mirror and working directly on the surface. The tablet is thus seen through the mirror, and the screen by reflection from it.

The orientation of the mirror relative to the two surfaces determines the apparent angular orientation of the display and tablet images. When the mirror exactly bisects the angle formed by these surfaces, they appear to lie in parallel planes--at the same angle and orientation.

The vertical placement of the mirror determines the apparent height of the display screen. When the mirror is midway between the screen and the tablet surface (i.e., when its plane intersects the vertex of the angle formed by the surfaces), the display image and tablet

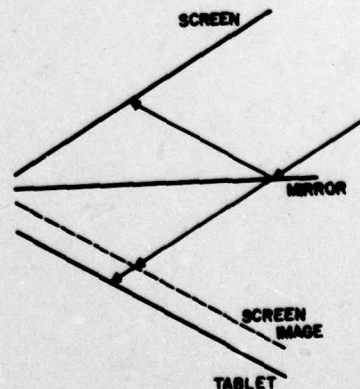
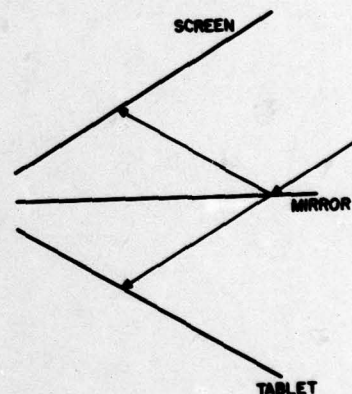
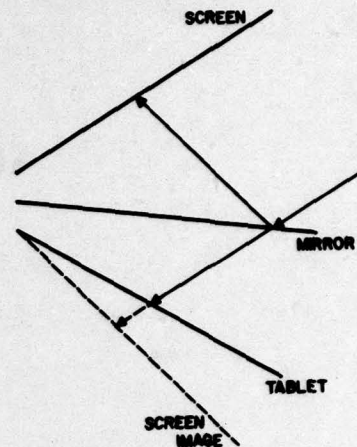

surface appear in precisely the same plane, in perfect register. This registration exists for all viewing positions above the mirror.

The relative visibility of either surface is controlled by their relative brightness and the transparency of the mirror. Projector brightness is controlled by direct adjustment of the projector. Tablet brightness is controlled by adjustment of a set of lights placed below the mirror and aimed downward, at the tablet surface. Normally the tablet itself is painted matte black so that no background illumination dilutes the display. Objects on it, such as pens and hands, reflect light, and show up clearly through the mirror.

### 2.1 The Back Projection Screen

In Knowlton's original implementation of the telephone operator's console, a standard television monitor provided the display image. This had the disadvantage that the resulting image was curved, necessitating a similarly curved keyboard below. In this work, we required a flat display surface, so that the image would conform to an already flat tablet, and because the flatness was perceived as mandatory for satisfactory direct interaction with graphics.

A curved screen and a curved tablet, even if available, would have resulted in an extremely unfamiliar working surface, and one not readily amenable to digitization of hard copy. We thus chose to use a rear projected image and experimented with a wide variety of screens and correction lenses to generate uniform image brightness across the entire display.

Design of a rear projection system is optimized for a given resolution, viewing area, and brightness, and the parameters that are controllable are the gain of the screen and its inherent resolution. Gain is a measure of the apparent brightness as a function of the angle of view. A low gain screen disperses lights more evenly over wider angles, and thus permits the largest viewing area. The entire surface appears uniformly bright. Better resolution is obtained with high gain screens. However, high gain screens provide proportionately more light in the direction of projection, causing image brightness to fall off at the edges. In this system, uniform brightness is especially important, since it is the relative screen/tablet brightness that determines the degree of transparency of the hand and hard copy.

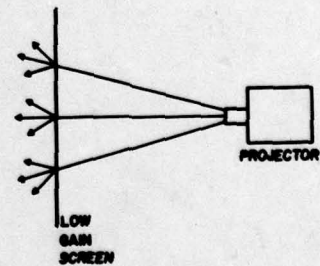
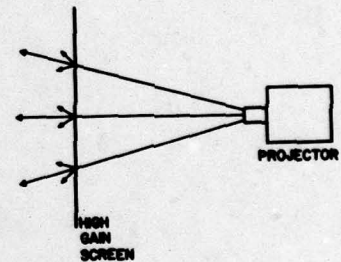

If the screen appears dimmer at the edges, the brighter appearance of the hand washes out the display image and seriously interferes with the utility of the station. Since high resolution was desirable in addition to brightness requirements, there was a problem.

The solution adopted was a high gain screen in combination with a fresnel corrector plate. The correction lens redirects the divergent projection beam to a distant focus, and results in an evenly bright screen over a somewhat reduced viewing area. In arriving at this solution, a variety of screens and lenses were tested. Ultimately a gain of 2.5, in conjunction with a fresnel with a focal length of 50 inches proved optimal.

## 2.2 The Transparency Mirror

The superimposition mirror is critical, since it creates the basic effect unique to this system and it determines the relative brightness range of the tablet vs. the screen. Glass mirrors were obtained with various silver coatings that resulted in transparency/reflectivity coefficients of 75/15; 60/35; 45/45; these were used to explore the range of effects. In general, a sheet of glass can be coated for any degree of reflectivity desired. The screen selected had a half silvered mirror.

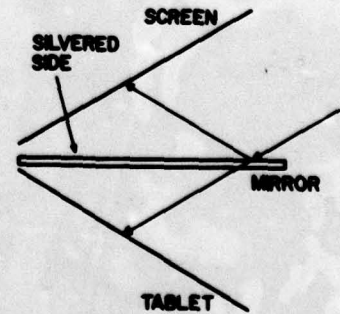
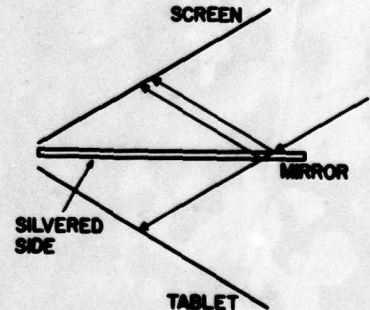
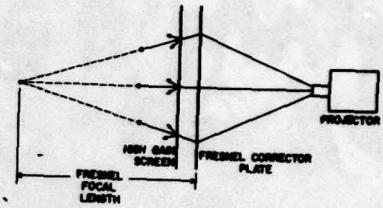

The mirror is placed so that the silvered side is up. Thus, the display screen is seen through first surface reflection and the tablet is seen through the glass. The reverse arrangement is impractical since the mirror often is viewed at a small angle of incidence where any internal glass reflections would lower the effective resolution of the screen.

The height of the mirror is adjustable so that a wide variety of tablet surfaces and thicknesses can be used without sacrificing superimposition of the surfaces.

### 2.3 The Tablet

Two digitizing tablets were used. One was a standard twenty inch square data tablet (Summagraphics); the other a touch panel specially designed for the project by Elographics.\* Both were painted black so that their actual surface was invisible, and in the case of the Summagraphics, the pen body and its connecting wire were similarly painted. The appearance of a virtual writing surface is created by the display image, not the actual brightness of the tablet surface, so it need not reflect any light of its own.

\*Elographics Corp., Oak Ridge, Tennessee



Of the two devices, the touch panel provides the more interesting application. In normal use, a touch panel's full resolution is rarely used either because there is no way to align a touch with a display datum due to parallax, or because a tracking cursor is not possible. Additionally, the resolution capability of a finger is often underestimated because of its size and blunt end. We felt that the ability to see through the finger would allow precise positioning.



### 3.0 ILLUSTRATIVE USES

We tested the device (informally so far) by two methods. In the first, a series of "games" was played in which the features of coincidence and transparency were evaluated; in the second, the ability of users to make annotations superimposed on hard copy was assessed.

#### 3.1 Games

Three games were developed for this test. Their common aim was to compare a user's ability to react to dynamically changing display data. The common underlying feature in all these tests, besides their ability to measure the difference between reactions to a separate tablet/display versus a coincident one, is their relation to dynamic command and control situations.

They are played as follows:

HIT: In this game, targets appear, randomly placed and at random intervals. The player must touch each as it appears and is scored on the number accurately touched within a set time interval. This game is a paradigm for an active command and control station where rapid reaction to dynamically changing situations is necessary. Possible applications derived from this game include air traffic control operations and military situation analysis. The fact that a user can see an object under the hand and that the hand can move directly to a point on the display without the aid of cursors is considered important.

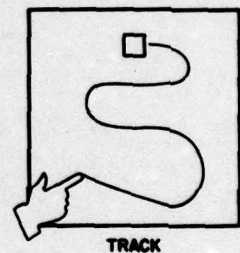
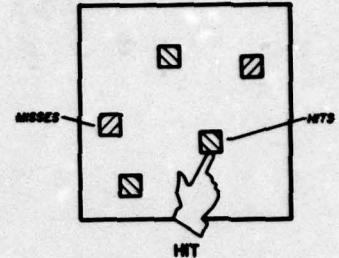

TRACK: In this game, one of several moving targets must be followed either with the tablet pen or the finger (depending on which input device is in use). The relative benefits of having the display and input surface coincident can be assessed, since an object moving in a given direction requires a user motion in the same direction. Likewise, the ability to see through one's hand allows motion in directions that are not simple or intuitively clear with alternative displays.

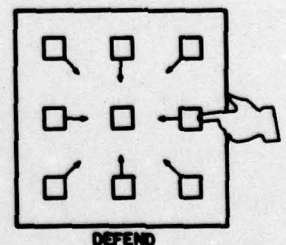

DEFEND: In this game, one of several objects gradually moves toward the center of the display screen. When the moving one is touched, another takes up the motion. This game tests some of the same features as the previous two, but in different combinations. The hand is continuously on the display surface and the likelihood that motion will occur in an object under the hand is greater than in other games.

### 3.2 Annotations

Two forms of annotation were attempted. In one, the object was to digitize a hard copy map, schematizing the main features of the terrain such as roads, rivers, towns and mountains. A sketching program was provided that permitted rapid generation of basic map symbology. The goal was to allow unskilled persons to trace map features, and to add changing computer data to a hard copy map. In the second, the sketching application was distilled to one basic feature: curve tracing. A single curve was displayed, and the user attempted to follow its contours. In all cases where hard copy was placed on the tablet, a negative image was used so that only highlights would appear.



#### 4.0 EVALUATIONS

Although only informal testing was conducted, several intuitive guidelines and implications of the work have emerged.

Annotations appear to be a particularly useful application of the device, the only difficulty being the creation of negative hard copy images. Of primary advantage is the co-planar nature of the input surface and the display image. People unskilled at drawing had little difficulty tracing the map, and appreciated the directly visible feedback. This is contrasted with separate tablet/display combinations where continually "looking up" at the display screen to check progress and verify input is disorienting and confusing. The parallax-free nature of the device and the similarity of scale also help simplify the task.

The dynamic tests also were successful. Lab personnel consistently were able to touch appearing targets faster with the seeing through your hand system than with a separate tablet and display. In this case, the scale is the primary advantage--it is simple to move directly to the place where an object appears, and difficult to make a proportional motion on a disjoint surface.

This success is mitigated however, by the similar success obtained with transparent tablets overlaid on a curved screen. These tests do not require the high resolution capabilities of the system, but merely prove the value of having the display at least close to the tablet, and nearly co-planar. Further, the device does not greatly enhance the user's ability to track an object once that object is initially touched.

In general, users readily acclimated themselves to the unfamiliar setting and became comfortable with the system. Gradually, users learned to make the display clearer by dimming the tablet illumination lights under the mirror. It is startling to realize how minimally visible the hand must be for use of the tablet--people rapidly relied upon the display image to obtain feedback of their hand and pen positions.

In terms of implementation, there are several areas for improvement. The weakest and most critical link is the television projector and rear projection screen. Because of the high cost of projection, it is the major impediment to adoption of the device. Unfortunately, it is currently a necessary component of our interactive device, both to provide

the requisite brightness and flatness. There is, however, some hope for substitutes in the near future. Broader user interest in larger displays has generated industry investigations into less expensive alternatives. Since the image for our device is not extremely large (only 20" square), direct projecting color CRT's are possible, and directly viewable flat panels are closer to realization.

Both new approaches to flat display design have the advantage that they would permit a more compact, more easily adjustable implementation of our ideas. With the flat panel, the device could be constructed as a small portable structure for use on a desktop.

The touch panel part of the design has disadvantages and advantages. Common touch panels are directed toward applications where simple pointing suffices.<sup>2</sup> They normally do not allow hands to be rested on them (because of the resulting touch signal), and resolution is not a highly prized goal.

However, Elographics has recently designed a device that detects touch only with high forces per unit area. Thus a hand may rest on the surface and be invisible to the computer, but the high load imposed by a penpoint will be detected. This will allow the

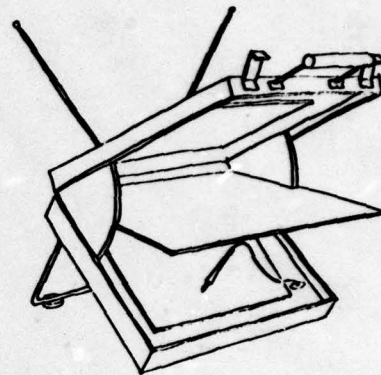

<sup>2</sup>The unavailability of a tracking cursor on touch panels need not be a disadvantage to the user. Just as the near-field was disregarded in the digitizing tablet, it is not necessary with a touch panel. In short, a cursor is not necessary for accurate display interaction. Cursors are an artifact of the disjoint input and display surfaces in other systems and provide feedback as to exact pen position. In this system, that feedback is automatic, and need not be provided artificially.

use of normal, inactive stylii, on a high resolution surface. The combination of inexpensive, flat displays and Elographics type tablet would result in a highly flexible and easy to use interactive graphic device.