

AD-A075 485

NAVAL AIR ENGINEERING CENTER LAKEHURST NJ
OPTIMUM INTENSITY SETTINGS OF APPROACH AND RUNWAY LIGHT SYSTEMS--ETC(U)
AUG 79 C A DOUGLAS

F/G 17/7

DOT-FA77WAI-786

UNCLASSIFIED

FAA/RD-79-87

NL

| OF |

AD
A075485



END
DATE
FILMED
11-79
DDC

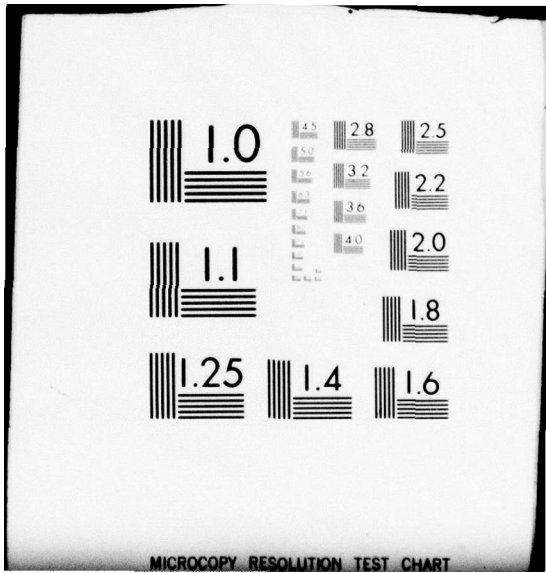

MICROCOPY RESOLUTION TEST CHART

12 LEVEL II

Report No. FAA-RD-79-87

AD A 075485

Optimum Intensity Settings of Approach and Runway Light Systems

Charles A. Douglas



DDC
RECEIVED
OCT 24 1979
B

August 20, 1979

Final Report

DDC FILE COPY

Document is available to the U.S. public through
the National Technical Information Service,
Springfield, Virginia 22161.

Prepared for

U.S. DEPARTMENT OF TRANSPORTATION
FEDERAL AVIATION ADMINISTRATION
Systems Research & Development Service
Washington, D.C. 20590

79 10 22 084

NOTICE

This document is disseminated under the sponsorship of the Department of Transportation in the interest of information exchange. The United States Government assumes no liability for its contents or use thereof.

1. Report No. 18 FAA/RD-79-87	2. Government Accession No.	3. Recipient's Catalog No. 12 86	
4. Title and Subtitle 6 Optimum Intensity Settings of Approach and Runway Light Systems		5. Report Date August 20, 1979	6. Performing Organization Code NAEC 911
7. Author(s) 10 Charles A. Douglas		8. Performing Organization Report No.	
9. Performing Organization Name and Address → Naval Air Engineering Center Lakehurst, New Jersey 08733		10. Work Unit No. (TRAIS)	11. Contract or Grant No. 15 DOT FA77 WAI-786
12. Sponsoring Agency Name and Address Department of Transportation Federal Aviation Administration Systems Research and Development Service Washington, D.C. 20590		13. Type of Report and Period Covered Final - August 20, 1979	
14. Sponsoring Agency Code ARD-432		15. Supplementary Notes This study was performed by Quanta Systems Corporation, 979 Rollins Avenue, Rockville, Maryland 20852, under NAEC contract N68335-78-C-2022.	
16. Abstract → Criteria for determining the optimum intensity settings of approach and runway lights as a function of atmospheric transmissivity and/or meteorological visibility, have been developed. In determining the optimum intensity settings, consideration was given to past practices, theoretical and experimental studies, and to the effects of the intensity setting on runway visual range. Changes in the present intensity setting criteria are recommended. ← 9 Final rept.,			
17. Key Words Airport Lighting Aids, Approach Lights, Runway Lights, Visual Aids for Airports, Optimum Intensity Settings		18. Distribution Statement Document is available to the public through the National Technical Information Service, Springfield, Virginia 22161.	
19. Security Classif. (of this report) UNCLASSIFIED	20. Security Classif. (of this page) UNCLASSIFIED	21. No. of Pages 83	22. Price

245 800

PA-104
INT

METRIC CONVERSION FACTORS

Symbol	When You Know	Multiply by	To Find	Symbol
LENGTH				
mm	millimeters	0.04	inches	in
cm	centimeters	0.4	inches	in
m	meters	3.3	feet	ft
m	meters	1.1	yards	yd
km	kilometers	0.6	miles	mi
AREA				
cm ²	square centimeters	0.16	square inches	in ²
m ²	square meters	1.2	square yards	yd ²
km ²	square kilometers	0.4	square miles	mi ²
ha	hectares (10,000 m ²)	2.5	acres	acres
MASS (weight)				
g	grams	0.028	ounces	oz
kg	kilograms	2.2	pounds	lb
t	tonnes (1000 kg)	1.1	short tons	short tons
VOLUME				
ml	milliliters	0.03	fluid ounces	fl oz
l	liters	2.1	pints	pt
l	liters	1.06	quarts	qt
l	liters	0.26	gallons	gal
m ³	cubic meters	35	cubic feet	ft ³
m ³	cubic meters	1.3	cubic yards	yd ³
TEMPERATURE (exact)				
°C	Celsius temperature	9/5 (then add 32)	Fahrenheit temperature	°F

Symbol	When You Know	Multiply by	To Find	Symbol
LENGTH				
in	inches	2.5	centimeters	cm
ft	feet	30	centimeters	cm
yd	yards	0.9	meters	m
mi	miles	1.6	kilometers	km
AREA				
in ²	square inches	6.5	square centimeters	cm ²
ft ²	square feet	0.09	square meters	m ²
yd ²	square yards	0.8	square meters	m ²
mi ²	square miles	2.6	square kilometers	km ²
acres	acres	0.4	hectares	ha
MASS (weight)				
oz	ounces	28	grams	g
lb	pounds (short tons (2000 lb))	0.45	kilograms	kg
		0.3	tonnes	t
VOLUME				
teaspoons	teaspoons	5	milliliters	ml
fl oz	fluid ounces	15	milliliters	ml
c	cups	30	milliliters	ml
pt	pints	0.47	liters	l
qt	quarts	0.95	liters	l
gal	gallons	3.8	liters	l
ft ³	cubic feet	0.03	cubic meters	m ³
yd ³	cubic yards	0.76	cubic meters	m ³
TEMPERATURE (exact)				
°F	Fahrenheit temperature	5/9 (after subtracting 32)	Celsius temperature	°C

*1 in = 2.54 centimeters. For other exact conversions and more detailed tables, see NBS Mon. Publ. 286, Units of Length and Capacity, NBS 12-25, 30, Catalog No. C13-10-286.

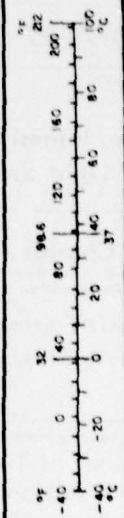

PHOTOMETRIC CONVERSION FACTORS

ILLUMINANCE

One footcandle = 10.76 lux = 1.076×10^7 kilometer candles = 2.79×10^7 mile candles*.

One mile candle* = 3.59×10^{-8} footcandle = 0.386 kilometer candle = 3.86×10^{-7} lux.

One lux = 10^6 kilometer candles = 2.59×10^6 mile candles* = 0.0929 footcandle.

One kilometer candle = 10^{-6} lux (one microlux) = 2.59 mile candles* = 9.29×10^{-8} footcandle.

* When English units are used, the usual practice is to use the term mile candle when the unit of length is a statute mile and sea-mile candle when the unit of length is a nautical mile. One mile candle is equal to 1.324 sea-mile candles.

LUMINANCE

One candela per square foot = 3.382×10^{-3} lambert = 3.382 millilamberts = 10.76 candelas per square meter = 3.142 footlamberts.

One footlambert = 0.3183 candela per square foot = 1.076×10^{-3} lambert = 1.076 millilamberts = 3.426 candelas per square meter.

One candela per square meter = 0.2919 footlambert = 9.290×10^{-2} candela per square foot = 3.142×10^{-4} lambert = 0.3142 millilambert.

One lambert = 10^3 millilamberts = 3.183×10^3 candelas per square meter = 9.290×10^2 footlamberts = 2.957×10^2 candelas per square foot.

One millilambert = 3.183 candelas per square meter = 0.9290 footlambert = 0.2957 candela per square foot = 10^{-3} lambert.

TABLE OF CONTENTS

	<u>Page</u>
1. INTRODUCTION	1
1.1 Scope	1
1.2 Objective of this Study	1
2. PRESENT INTENSITY SETTING CRITERIA FOR NIGHT-TIME CONDITIONS	2
2.1 Federal Aviation Administration (FAA) Practices	2
2.2 Night-time Intensity Setting Criteria of other Countries	4
3. FUNDAMENTAL ASPECTS OF THE NIGHT-TIME INTENSITY SETTING PROBLEM	7
3.1 Aspects with Systems Which Do Not Significantly Affect the Ambient Background Luminance	7
3.2 Aspects with Systems Which Themselves Significantly Increase the Background Luminance	12
3.2.1 Effects on the Visual Range of the Lights	12
3.2.2 Effects on the Glare Produced by the Lights	17
4. HISTORICAL RÉSUMÉ OF INTENSITY SETTING CRITERIA IN THE U.S.	18
4.1 Early Criteria	18
4.2 Air Force Night-time Intensity Setting Criteria, 1950-1968	19
4.3 FAA Night-time Intensity Setting Criteria	20
4.4 Night-time Intensity Setting Criteria for Touchdown Zone and Runway Centerline Lights	20
4.5 Night-time Intensity Setting Criteria for Medium Intensity Approach and Runway Lights	21
4.5.1 Runway Lights	21
4.5.2 Approach Lights	22
5. STUDIES OF INTENSITY SETTING CRITERIA	23
5.1 Work of J. B. Bartow	23
5.2 National Bureau of Standards Tests and Studies	23

	<u>Page</u>
5.2.1 Nantucket and Indianapolis Tests	23
5.2.2 Tests at the Landing Aids Experiment Station (LAES) . .	25
5.2.3 Tests at the Naval Air Test Center (NATC)	27
5.3 FAA Studies	28
5.3.1 Intensity Setting Criteria for Slope-Line Approach Light System	28
5.3.2 Intensity Setting Criteria Developed by the U.S. Advisory Committee on Visual Aids to Approach and Landing	29
5.4 Theoretical Study of Padmos and Vos	30
5.5 Related Laboratory Studies	31
5.6 Summary of Night-time Intensity Criteria	33
5.7 Recommended Night-time Intensity Setting Criteria	35
5.7.1 Recommended Night-time Intensity Setting Criteria for Steady Burning, High Intensity Light Systems . . .	35
5.7.2 Recommended Night-time Intensity Setting Criteria for Steady Burning, Medium Intensity Approach and Runway Light Systems	38
5.8 Intensity Setting Criteria for Sequenced Flashers	40
5.9 "Simplified" Approach Light Systems	42
5.10 An Alternate Intensity Control Procedure Optimum Daytime Intensity Setting Criteria	43
6. OPTIMUM DAYTIME INTENSITY SETTING CRITERIA	43
6.1 Theoretical Considerations	43
6.2 Recommended Daytime Intensity Setting Criteria	46
7. INTENSITY SETTING CRITERIA FOR TWILIGHT	49
8. DISCUSSION OF RECOMMENDED INTENSITY SETTING CRITERIA . .	50
8.1 Restrictions to Application	50
8.2 Possible Problems Resulting from Differences in Lamp Characteristics	50
8.3 Methods of Accomplishing Intensity Adjustment	52
8.4 Relation of Intensity Setting Criteria to RVR Assessments	54

	<u>Page</u>
8.4.1 Night-time Conditions	54
8.4.2 Daytime Conditions	56
8.4.3 Twilight Conditions	56
8.5 Considerations for a Test Program	57
9. CONCLUSIONS	58
10. RECOMMENDATIONS	58
REFERENCES	59
ACKNOWLEDGEMENTS	62
APPENDIX I PRESENT FAA INTENSITY SETTING CRITERIA	I-1
APPENDIX II VISUAL RANGE OF LIGHTS AND OBJECTS	II-1
II-1 Allard's Law	II-1
II-2 Koschmieder's Law	II-2
II-3 Relation Between the Visual Range of Lights and Daytime (Meteorological) Visibility	II-3
II-4 Representative Intensity	II-4
II-5 Effective Intensity	II-4
APPENDIX III BRILLIANCY RATING SCALE FOR APPROACH AND RUNWAY LIGHTS	III-1
APPENDIX IV LIST OF AIRPORTS WHERE USED IN LIGHT INTENSITY SETTINGS UNDER DIFFERENT METEOROLOGICAL CONDITIONS BY U.S. ADVISORY COMMITTEE ON VISUAL AIDS FOR APPROACH AND LANDING (1972)	IV-1
APPENDIX V VISUAL RANGE OF THE RUNWAY AND ITS SURFACE MARKINGS	V-1

ACCESSION for	
NTIS	White Section <input checked="" type="checkbox"/>
DDC	Buff Section <input type="checkbox"/>
UNANNOUNCED	<input type="checkbox"/>
JUSTIFICATION _____	
BY _____	
DISTRIBUTION/AVAILABILITY CODES	
Dist.	AvAIL. and/or SPECIAL
A	-

LIST OF FIGURES

	<u>Page</u>
1. Minimum Illuminance at the Eye from an Achromatic (White) Point Source for about 98 Per Cent Probability of Detection as a Function of the Background	8
2. Background Luminance Produced by Runway and Approach Lights	13
3. Block Diagram of NBS Automatic Intensity Control System	25
4. Night-time Intensity Settings Obtained from NBS Automatic Intensity Control System	26

LIST OF TABLES

<u>Table</u>		<u>Page</u>
I	Intensity Settings Used by the FAA for Steady-Burning Lights Under Night-time Conditions	2
II	Intensities of Steady-Burning Lights Set in Accord With FAA Night-time Intensity Setting Criteria	3
III	Representative Intensities of U. S. Approach and Runway Lights When Operated at Full Current or Voltage	4
IV	Light Intensities (in Candelas) for Night-time Conditions Listed by the Visual Aids Panel	5
V	Typical Minimum Distances at Which Aircraft Is Within the Main Beam	10
VI	Intensities (in Candelas) Which Will Cause Nearest Lights to Become Glaring at Night	11
VII	Threshold Illuminances Applicable to RVR Computations When The Effect of the Lighting Systems On the Background Luminance Is Considered	14
VIII	Visual Range (in Feet) as a Function of Intensity Setting Step Night .	15
IX	Night-time Intensity Setting Criteria Circa 1943-1950	19
X	Air Force Night-time Intensity Setting Criteria of 1954 and 1958.	19
XI	FAA Night-time Intensity Setting Criteria For the ALS and HIRL, 1968 to Date	20
XII	Air Force Night-time Intensity Setting Criteria for Medium Intensity Runway Lights	21
XIII	FAA Night-time Intensity Setting Criteria for MIRL	21
XIV	FAA Night-time Intensity Setting Criteria for Three-Step MALS . . .	22
XV	FAA Night-time Intensity Setting Criteria for Two-Step MALS	22

<u>Table</u>		<u>Page</u>
XVI	Night-time Intensity Settings Provided by Automatic Control at LAES and NATC	27
XVII	Optimum Intensity Settings for Slope-Line Approach Lights	29
XVIII	Night-time Intensity Setting Criteria Developed by U.S. Advisory Committee On Visual Aids for Approach and Landing	29
XIX	Night-time Intensity Settings (in Candelas) Developed by Padmos and Vos	31
XX	a. Summary of Night-time Intensity Setting Practices for High Intensity Approach Lights	34
	b. Summary of Night-time Intensity Setting Practices for High Intensity Runway Edge Lights	34
	c. Summary of Intensity Setting Practices for Touchdown Zone Lights	34
	d. Summary of Intensity Setting Practices for Runway Centerline Lights (50 ft. Spacing)	34
XXI	Recommended Night-time Intensity Settings for Steady Burning, High Intensity Light Systems	36
XXII	Comparison of Recommended Night-time Intensity Setting Criteria, Present U.S. Practice and Advisory Committee Proposal	37
XXIII	Recommended Intensity Night-time Intensity Settings for Steady Burning, Medium Intensity Light Systems	38
XXIV	Comparison of Recommended Night-time Intensity Setting Criteria for Medium Intensity Approach Light Systems and Present U.S. Practice	39
XXV	Comparison of Recommended Night-time Intensity Settings for Medium Intensity Runway Lights Using Type L802 Lights and Present Practice	40
XXVI	Intensity Control of Flashers	41

<u>Table</u>	<u>Page</u>
XXVII	Relation Between Intensity Settings of the ALS and the MALS and the Sequenced Flashers 41
XXVIII	Conditions Under Which the Visual Range of Approach and Runway Lights Is Equal to the Daytime (Meteorological) Visibility 44
XXIX	Intensity (in Candelas) Required of a Light to Produce a Visual Range of One Mile 45
XXX	Visual Range (in Feet) of Approach and Runway Lights Operating at Full Intensity During Conditions of Low Visibility 46
XXXI	Recommended Daytime Intensity Setting Criteria for Steady Burning Lights 47
XXXII	Comparison of Recommended Daytime Intensity Setting Criteria with Present U.S. Practice and Advisory Committee Proposal. 48
XXXIII	Measured Relative Intensities of Several Lamp Types as a Function of Intensity Setting Step. 51
XXXIV	Decrease in Values of RVR Resulting from Use of Recommended Night-time RVR Intensity Setting Criteria 55

ABBREVIATIONS

ALS	Standard U.S. Configuration A high intensity approach light system
CAA	U.S. Civil Aeronautics Administration (now FAA).
FAA	Federal Aviation Administration, Washington, D.C. 20590
HIRL	U.S. High intensity runway light system
ICAO	International Civil Aviation Organization, P. O. Box 400, Succarsale; Place de l'Aviation Internationale, 1000 Sherbrooke St. West, Montreal, Quebec, Canada H3A2R2
IGIA	Intergovernmental Group on International Aviation
ILS	Instrument landing system
LAES	Landing Aids Experiment Station, Arcata, CA (closed 1950)
MALS	U.S. Medium intensity approach light system
MALSF	MALS with three sequenced flashers 1000, 1200, and 1400 feet from threshold
MALSR	MALS with runway alignment indicator lights, an economy system used for precision approaches
MIRL	Medium intensity runway (edge) light system
NATC	Naval Air Test Center, Patuxent River, MD
NBS	National Bureau of Standards, Washington, D.C. 20234
RCLS	Runway centerline light system
RVR	Runway visual range
RVV	Runway visibility
SFL	Sequenced flashing lights
TDZL	Touchdown zone lighting system
VAP	Visual Aids Panel (of ICAO)

OPTIMUM INTENSITY SETTINGS
OF
APPROACH AND RUNWAY LIGHT SYSTEMS

1. INTRODUCTION

1.1 Scope

This report gives the results of a study of the problem of determining the optimum intensity settings of approach and runway light systems as a function of atmospheric transmittance. This study was undertaken at the request of the Federal Aviation Administration Office of airports programs to determine the optimum intensity settings for approach and runway light systems under various meteorological conditions down to one-fourth mile visibility and to provide information for use by a Working Group of the International Civil Aviation Organization for purposes of international standardization. The study was conducted as part of contract N68335-78-C-2022 with Quanta Systems Corporation, Rockville, Maryland. It consists of a review of the literature, a historical review, an analysis of past and present intensity setting criteria, a review of experimental and theoretical studies of intensity setting criteria, and recommendations for intensity settings based upon these studies.

1.2 Objective of this Study

The objectives of this study were:

1. To determine the optimum intensity settings for pilots during landing and take-off of the approach, runway edge, touchdown zone and centerline lights as a function of visibility restrictions.
2. To evaluate the effect, as a function of visibility restrictions, on the Runway Visual Range (RVR) of using the proposed intensity settings in place of the present settings.
3. To recommend the changes, if any, in existing procedures for intensity settings required to achieve better visual guidance for aircraft operations at airports.

2. PRESENT INTENSITY SETTING CRITERIA FOR NIGHT-TIME CONDITIONS

2.1 Federal Aviation Administration (FAA) Practices

The intensity setting criteria used by the FAA are listed in FAA Document 7110.65A [1]. (See Appendix I) Intensity settings for selected night-time visibility conditions, based upon present criteria, are shown in Table I.

Table I. INTENSITY SETTINGS USED BY THE FAA FOR STEADY-BURNING LIGHTS UNDER NIGHT-TIME CONDITIONS^o *

Visibility (miles)	Intensity Setting Step/(Percent of full intensity)						
	ALS	MALSR-3 Step	MALSR-2 Step	HIRL	TDZL	RCLS	MIRL-3 Step
Greater than 5	1/(0.16)	1/(4)	LOW/(4)	1/(0.16)	1/(0.16)	1/(0.16)	1/(10)
5	1/(0.16)	1/(4)	LOW/(4)	2/(0.8)	2/(0.8)	2/(0.8)	1/(10)
4	1/(0.16)	1/(4)	LOW/(4)	2/(0.8)	2/(0.8)	2/(0.8)	1/(10)
3	2/(0.8)	1/(4)	LOW/(4)	2/(0.8)**	2/(0.8)	2/(0.8)	2/(30)
2.5	2/(0.8)	2/(20)	HIGH/(100) ⁺	3/(4)	3/(4)	3/(4)	2/(30)
2	2/(0.8)	2/(20)	HIGH/(100) ⁺	3/(4)	3/(4)	3/(4)	2/(30)
1***	2/(0.8)	2/(20)	HIGH/(100) ⁺	3/(4)	3/(4)	3/(4)	2/(30)
Less than 1***	3/(4)	3/(100)	HIGH/(100) ⁺	4/(20)	4/(20)	4/(20)	3/(100)

* Based upon FAA Publication 7110.65A [1].

**Step 3/(4) when used with MALSR.

*** or 6000 ft RVR.

⁺RAIL ON

The criteria given in Appendix I give only the intensity setting step and does not state the percent of full intensity which corresponds to each step for the several lighting systems listed. These percentages have been obtained from FAA Handbook 6850.2 [2] and are listed parenthetically in Table I. The representative intensities^{oo} produced by the light systems during the selected visibility conditions when the intensity settings are as indicated in Table I are listed in Table II. These representative intensities are derived from the representative intensities at full current or voltage, listed in Table III.

^o See page viii for list of abbreviations.

^{oo} See Appendix II for an explanation of the use of the term "representative intensity."

Table II. INTENSITIES OF STEADY-BURNING LIGHTS SET IN ACCORD WITH
FAA NIGHT-TIME INTENSITY SETTING CRITERIA *

Visibility (miles)	Intensity (Candelas)							MIRL ***
	ALS	MALS-3 Step	MALS-2 Step	HIRL **	TDZL	RCLS		
Greater than 5	45	240	240	26	10	8	250	
5	45	240	240	130	50	40	250	
4	45	240	240	130	50	40	250	
3	220	240	240	130	50	40	750	
2.5	220	1200	6000	640	240	200	750	
2	220	1200	6000	640	240	200	750	
1 ⁺⁺	220	1200	6000	640	240	200	750	
Less than 1 ⁺⁺	1100	6000	6000	3200	1200	1000	2500	

* From Publications 7110.8, "Air Traffic Control" 1968 and 7110.65, 1969, to 7110.65A, Chg. 4.

** Based upon Type L819 light.

*** Based upon Type L802 light.

+ 640 when used with MALSR.

++ or 6000 ft RVR.

Table III. REPRESENTATIVE INTENSITIES OF U. S. APPROACH AND RUNWAY LIGHTS WHEN OPERATED AT FULL CURRENT OR VOLTAGE

System	Light Type	Lamp Type	Representative Intensity* (Candelas)
ALS	FAA 982	Q20A/PAR56	28000
MALS	--	150 watt, PAR38/SP	6000
Sequenced Flashers	--	----	14000
HIRL	L819	6.6A T14P	16000
	L862	----	10000
TDZL	L850B	Q6.6A T4	6000
RCLS	L850A	Q6.6A T4	5000
MIRL	L802	6.6A/T10/1P (45-watt)	2500
	L861	----	125

* Of white (unfiltered) lights when new.

Note that the intensities listed in Table II for the MALS and the MIRL are significantly higher for the better visibility conditions than are the intensities listed for the "high" intensity systems. The rationale for these differences is not clear.

The percentage intensities corresponding to the intensity setting steps quoted in Table II and used throughout this report are nominal values and are in accord with the relative intensities listed in Handbook 6850.2 [2].

The relation between relative intensity and lamp current for different lamp types is not constant but varies somewhat with such factors as lamp wattage, lamp life and filament design, as shown in Figures 37 and 38 of NBS Report 6190 Supplementary [3].

2.2 Night-time Intensity Setting Criteria of other Countries

At its Sixth Meeting the Visual Aids Panel (VAP) of the International Civil Aviation Organization (ICAO) tabulated the intensities used by the countries represented in the Panel as part of an effort to obtain standardization of intensity

settings [4a]. The intensities listed were reaffirmed at the Seventh Meeting of the VAP [4b]. The intensities listed by the VAP for approach, runway edge, touchdown zone and centerline lights are listed in Table IV. To facilitate comparison with the intensities used by the U.S. for these lights, the intensities listed in Table II for the ALS, HIRL, TDZL and RCLS systems for the stated visibility conditions have been included parenthetically in Table IV.

Table IV. LIGHT INTENSITIES (IN CANDELAS) FOR NIGHT-TIME CONDITIONS LISTED BY THE VISUAL AIDS PANEL

RVR or Visibility Condition	Light Systems			
	Approach Centerline	Runway Edge	Touchdown Zone	Runway Centerline (50-foot spacing)
Greater than 3 miles (and cloud base above 500 ft)	Off to 400 (45)	30-300 (26-130)	10-100 (10-50)	10-100 (8-40)
6000-ft RVR to 3 mile vis. (or cloud base between 200 and 500 feet)	300-2000 (220)	100-1000 (130-640)	50-500 (50-240)	40-300 (40-200)
RVR 2600 to 6000 ft (or cloud base below 200 ft)	800-5000 (1100)	600-3000 (3200)	250-1500 (240-1200)	200-1000 (200-1000)
RVR 1200-2600 ft	2000-20000 (1100)	1000-10000 (3200)	500-5000 (1200)	200-1500 (1000)
RVR less than 1200 feet	2500-20000 (1100)	4000-10000 (3200)	600-5000 (1200)	600-2500 (1000)

Note: - Corresponding intensities used in the U.S., from Table II, have been included parenthetically.

These tables will be considered in some detail later in the report. At present, note will be taken only of the following:

The range of intensities listed by the VAP for a given light system at a given visibility condition is due in part to the break points between visibility conditions used by the VAP being different than the break points used by some of the countries reporting.

The agreement between the intensities listed by the VAP for runway edge, touchdown zone and centerline lights and U.S. practice is surprisingly close.

The intensities listed by the VAP for approach lights are typically about twice the intensities listed for the runway edge lights but the intensities used for the ALS by the U.S. are considerably lower than the intensities of the HIRL.

3. FUNDAMENTAL ASPECTS OF THE NIGHT-TIME INTENSITY SETTING PROBLEM

3.1 Aspects with Systems Which Do Not Significantly Affect the Ambient Background Luminance

If obtaining the maximum visual range from an approach or runway lighting system were the only criterion, determination of the optimum intensity setting for a given system and analysis of the performance of the system would, at first thought, be comparatively simple. Maximum range would be obtained with the lights operated at full intensity and the visual range would be computed from Allard's law,* namely

$$E_m = I_o T^D / D^2, \quad (1)$$

where

D is the visual range,

T is the atmospheric transmissivity (transmittance per unit distance),

I_o is the intensity of the light when operated at full current or voltage, and

E_m is the illuminance threshold applicable to the ambient background luminance.

The relation between the illuminance threshold and background luminance would be based upon a curve such as that shown in Figure 1.

* See Appendix II.

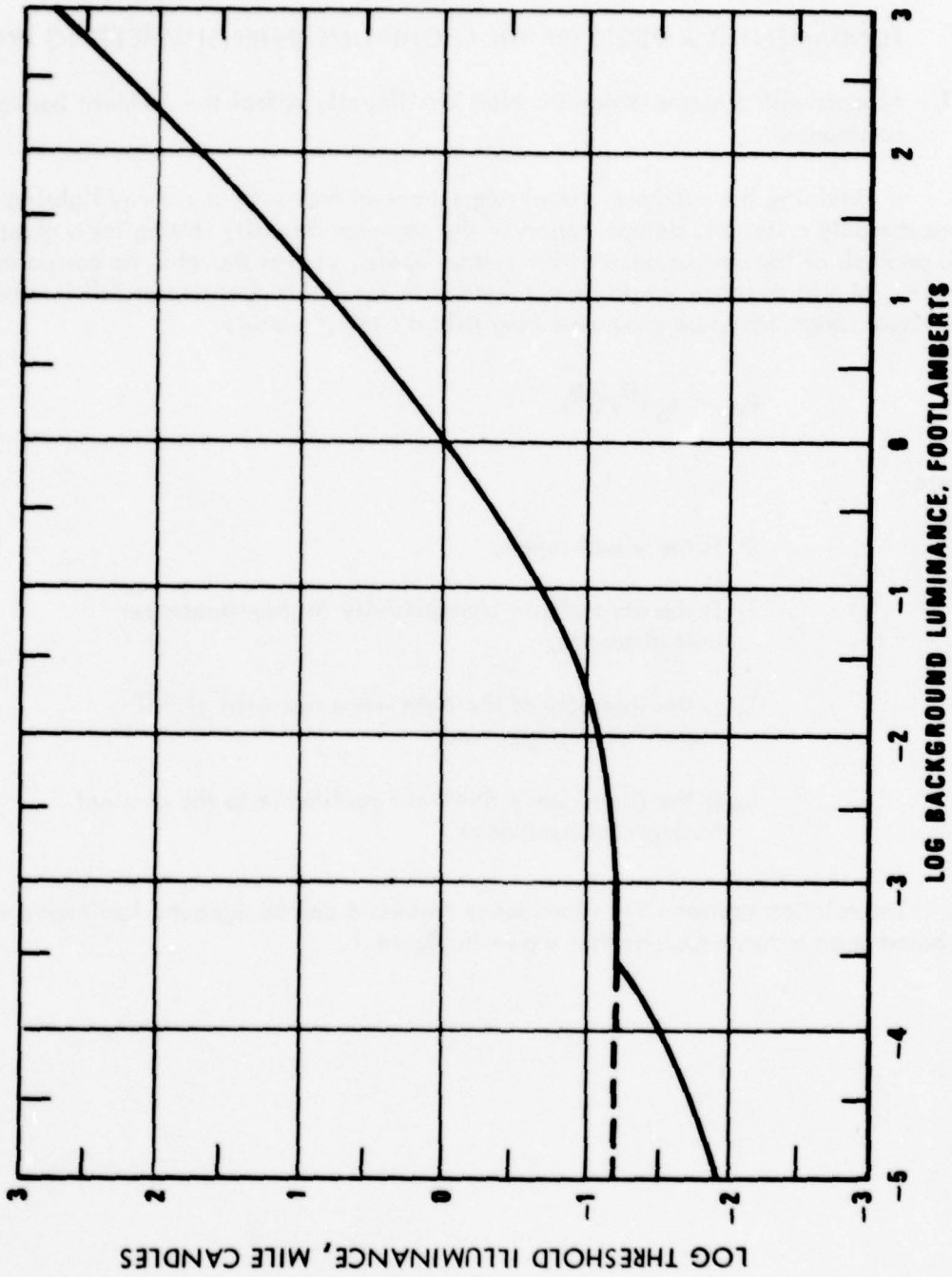

Figure 1. Minimum illuminance at the eye from an achromatic (white) point source for about 98 per cent probability of detection as a function of the background.

The threshold illuminance values shown in Figure 1 are not directly applicable to a pilot. They are applicable only under laboratory conditions where the observer knows precisely where and when to look for the light. In obtaining a curve applicable to the pilot such factors as the transmittance of the windshield, the effect of a moving observer, the effects of lighted instruments in the cockpit and the effects of the pilot's dividing his attention between looking for the lights and flying the airplane.

NOTE: In analyzing flight test data and in computing the visual range from aircraft, it is convenient and conventional to consider the illuminance incident on the windscreen, not on the pilot's eye, as the illuminance used in Allard's law. Thus, a correction must be applied to threshold data obtained without the interference of a windscreen. This factor usually has been ignored in applying laboratory or field data.

In consideration of such factors, a threshold illuminance of 0.5 mile candle was chosen as the threshold illuminance applicable to pilots in the 1930's. This value was accepted as applicable to shipboard lookouts by the International Association of Lighthouse Authorities in 1933 and is still being used in maritime applications. Because of the increase in the complexity of the flying task, the great increase in the number of lighted instruments and the increased losses in aircraft wind screens, a number of workers in the aviation field used an increased threshold illuminance of 1 mile candle in the 1940's. Later this was increased to 2 mile candles in the U. S. at the start of the RVR program. At the same time, but independently, a value of 1 microlux (2.5 mile candles) was recommended by the International Commission on Illumination. The choices of threshold illuminance were based primarily on engineering judgment with little, or no, hard evidence. Supporting evidence has, however, been obtained in subsequent studies [5]. Note that these threshold illuminances were intended to apply to the flat part of the curve of Figure 1.

Note that a threshold illuminance of 2 mile candles is approximately 10 times the threshold illuminance shown in Figure 1 for a background luminance of 10^{-1} foot-lambert. A factor of 10 will be used as a field factor in this study to convert threshold illuminances shown in Figure 1 to threshold illuminances applicable to the pilot.

Since approach and runway lights are also viewed during the course of an approach and landing at distances much less than their maximum range, consideration must be given to the possibility of annoying, or disabling, glare from the nearby lights. To some extent, the glare can be reduced by designing of the intensity distribution of the light beams so that the pilot is outside the main beam of the lights when the distance between the pilot and the light is short. (See Section 5.1) However, the application of this method is severely limited since the beams of the lights must be wide enough to

accommodate the expected deviations of the aircraft from the glide slope and centerline. Typical minimum distances at which the aircraft on glide slope (where applicable) and on centerline is within the main beam of present U.S. lighting fixtures are given in Table V.

Table V
TYPICAL MINIMUM DISTANCES AT WHICH
AIRCRAFT IS WITHIN THE MAIN BEAM

Light Type	Minimum Distance (feet)
Center Approach	750
Inner Approach	450
Runway Edge	530
Touchdown Zone	340
Centerline	170*

* Assuming 15 foot eye-to-wheel distance.

Field tests conducted by the National Bureau of Standards on Nantucket Island showed that when the illuminance produced by a light was 1000 times the threshold illuminance, the light is annoyingly bright, or glaring. Using this ratio, an illuminance of 2000 mile candles would be considered glaring. (See Appendix III.)

The intensity which would produce a "glaring" illuminance as a function of light system and fog density can then be computed by using the distances listed in Table V. This has been done for several visibilities (on the U.S. night visibility scale) and the results are shown in Table VI.

Table VI. INTENSITIES (IN CANDELAS) WHICH WILL CAUSE NEAREST LIGHTS TO BECOME GLARING AT NIGHT

System →			Outer ALS d = 750'	Inner ALS d = 450'	HIRLS d = 530'	TDZL d = 340'	RCLS d = 170'
Vis Miles	Vis Feet	t ₂₅₀					
5	26400	0.9620	45	15	20	10	2
3	15840	0.9300	50	20	25	10	2
2	10560	0.8883	60	20	25	10	2
1	5280	0.7636	90	25	35	10	2
1/2	2640	0.5461	250	45	70	20	3
1/4	1320	0.2615	2300	160	350	50	5
1/8	660	0.0526	300000	3000	10000	450	15

The intensities given in Table VI are based upon the assumption that the lighting systems have no effect on the ambient background luminance (and hence on the adaptation level of the eye) and that the presence of numerous lights (some of which are bright) within the field of view does not affect the "glaring" rating. Thus, these values are the lowest ones which would cause annoying glare.

Note the strong effect of minimum distance on the intensity which produces glare. The difference in the intensities between the outer and inner approach zone suggest the use of lights of different intensities and of separate intensity control for these two zones [6].

Note also the low intensities listed for the centerline lights.

It is apparent that if freedom from glare were the only criterion, only low intensities would be used at night for most of the lights. However, this procedure would result in an undesirable reduction in visual range. Hence, a compromise between glare and visual range is necessary.

The intensities listed in Table VI would be increased significantly if the minimum distances listed in Table V were increased by using narrower light beams and reaiming the lights so that their beam axes intercepted the glide slope or the runway centerline at a greater distance from the light. However, as shown in Section 5.1, this procedure is unacceptable.

3.2 Aspects with Systems which Themselves Significantly Increase the Background Luminance

3.2.1 Effects on the Visual Range of the Lights

Experience has shown that most approach and runway lighting systems do have a significant effect upon the background luminance and hence upon the adaptation level and threshold illuminance of the pilot, especially when the light systems are operated at, or near, full intensity and during periods of restricted visibility.

As can be seen from Figure 1, if the background luminance is not above 0.01 footlambert (clear, moonlight) there will be no change in the threshold illuminance with background luminance. However, if the lighting systems produce background luminances above about 10 footlamberts, the threshold illuminance varies nearly directly with the background luminance. Since the background luminance varies almost directly with the intensity of the lights in the system, the result is that the ratio of threshold illuminance to intensity becomes constant. As shown by equation (1), if the ratio E/I is constant, further increases in intensity will produce no increase in visual range.*

There are few data on the background luminances over approach and runway lighting systems. Such data as have been obtained should be considered only as a *rough approximation to the background luminances encountered by the pilot.*

Not only must one contend with the temporal and spatial variations in fog density and the effects of small changes in the direction at which the photometer is aimed, but even the field of view of the photometer will affect the values obtained. These data are, however, sufficient to illustrate the effects of the background luminance produced by the lighting systems on the visual range of these systems.

The most extensive set of background luminance data is that reported by Simeroth [7] and shown in Figure 2. Luminance data points obtained at the National Aviation Facilities Experimental Center (NAFEC) especially for this study and at Schiphol Airport [8] have been added to this figure.

The values shown in Figure 2 are based upon the systems operating at full intensity. Since nearly all the background luminance is produced by the lights themselves, the background luminances when the light systems are dimmed are 20% and 4% of the values shown on Figure 2 when all systems are dimmed to step 4 and step 3, respectively.

* The significance of this condition in producing a limiting range was first stated explicitly by Padmos and Vos. (See Section 5.4)

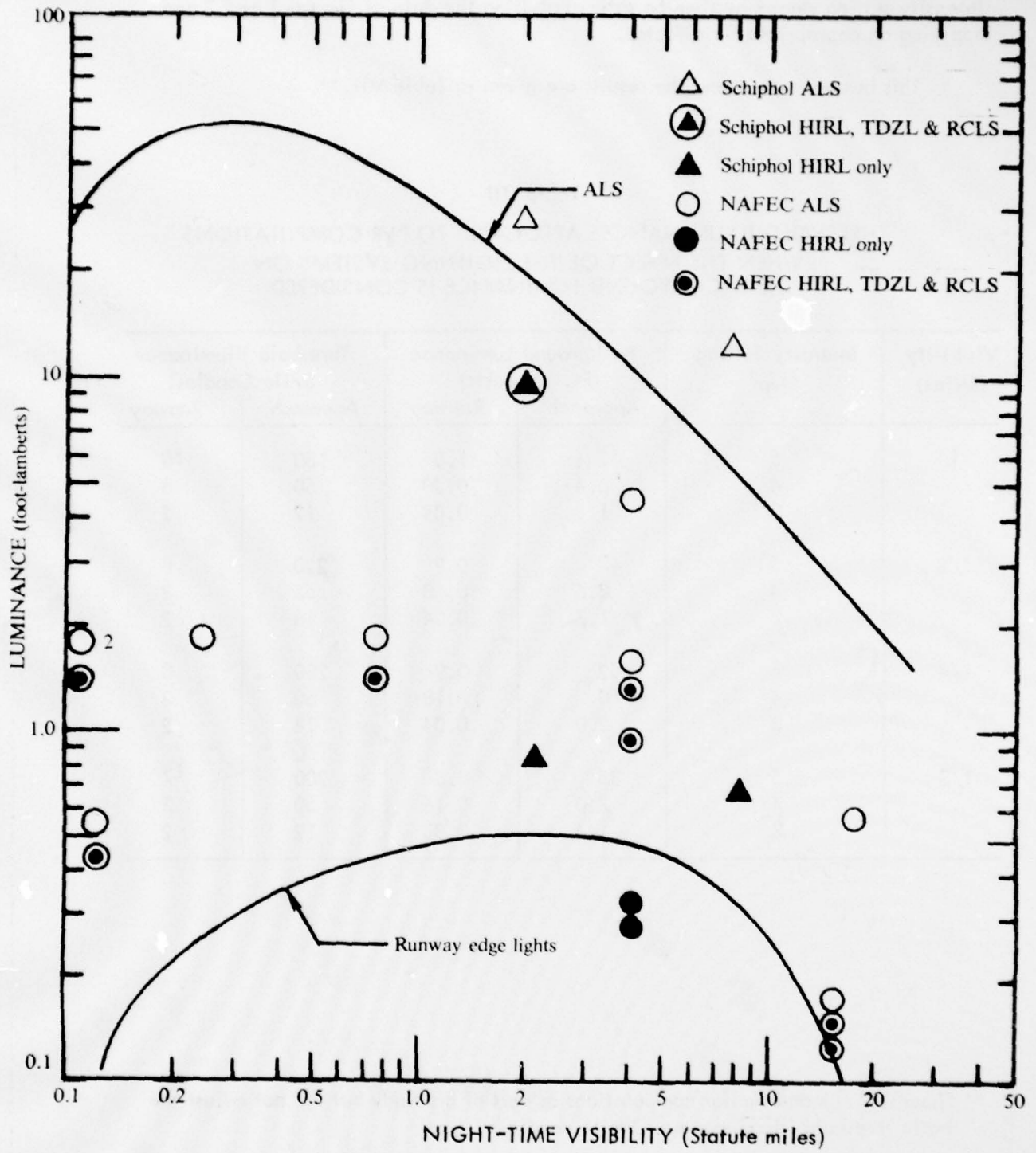

Figure 2. Background luminances produced by runway and approach lights.

Pilot threshold illuminances applicable to various visibility conditions and intensity setting steps may then be estimated using the data of Figures 1 and 2 and applying an appropriate field factor.

This has been done and the results are given in Table VII. **

Table VII
 THRESHOLD ILLUMINANCES APPLICABLE TO RVR COMPUTATIONS
 WHEN THE EFFECT OF THE LIGHTING SYSTEMS ON
 THE BACKGROUND LUMINANCE IS CONSIDERED

Visibility (Miles)	Intensity Setting Step	Background Luminance (Ft. Lamberts)		Threshold Illuminance (Mile Candles)	
		Approach	Runway	Approach	Runway
1	5	32	1.0	180	10
	4	6.4	0.20	50	3
	3	1.3	0.04	12	2
1/2	5	43	0.9	220	8
	4	8.6	0.18	55	3
	3	1.7	0.04	16	2
1/4	5	52	0.9	280	8
	4	10	0.18	60	3
	3	2.0	0.04	14	2
1/8	5	35	0.8	200	7
	4	7.0	0.16	50	3
	3	1.4	0.03	12	2

** Simeroth [7] made similar computations as part of his study but did not adjust the basic threshold illuminance to 2 mile candles.

The following assumptions were made in developing these threshold illuminances:

- a. The pilot threshold illuminances are 10 times the values obtained from Figure 1. (See page 9)
- b. The curve of Figure 2 designated as "ALS" has been used as a basis for the estimates of the luminances applicable to viewing approach lights.
- c. The estimates of background luminances applicable to the pilot over a runway lighted with HIRL, TDZL, and RCLS were based primarily upon the NAFEC measurements.
- d. All lighting systems are operated on the same intensity step.

The threshold illuminances shown in Table VII can be used to compute visual ranges applicable to the several visibility conditions and intensity setting steps listed in the table. This has been done and the results are given in Table VIII. Visual ranges computed assuming a fixed threshold illuminance of 2 mile candles are included parenthetically for comparison.

Table VIII. VISUAL RANGE (IN FEET) AS A FUNCTION OF INTENSITY SETTING STEP
NIGHT

Visibility (miles)	t_{250}	Intensity Step	Light System							
			ALS		HIRL		TDZL		RCLS	
			(1)	(2)	(1)	(2)	(1)	(2)	(1)	(2)
1	0.7636	5	4800	(8100)	6500	(7600)	5800	(6900)	5700	(6800)
		4	4600	(6900)	6200	(6500)	5500	(5800)	5400	(5600)
		3	4500	(5700)	5300	(5300)	4700	(4700)	4600	(4600)
1/2	.5461	5	2600	(4100)	3500	(4000)	3100	(3600)	3000	(3600)
		4	2500	(3600)	3300	(3400)	3000	(3100)	2900	(3000)
		3	2400	(3100)	2900	(2900)	2600	(2600)	2500	(2500)
1/4	.2615	5	1360	(2120)	1800	(2000)	1630	(1900)	1600	(1800)
		4	1350	(1870)	1700	(1800)	1550	(1600)	1500	(1600)
		3	1330	(1620)	1500	(1500)	1400	(1400)	1400	(1400)
1/8	.0526	5	750	(1100)	920	(1040)	850	(970)	840	(950)
		4	730	(960)	890	(920)	820	(850)	810	(840)
		3	720	(850)	810	(810)	740	(740)	730	(730)

(1) Computed assuming the threshold illuminances of Table VII.

(2) Computed assuming a fixed threshold illuminance of 2 mile-candles.

In addition, visual ranges of the HIRL, based upon a study made by Lefkowitz and Schlatter, of threshold illuminance using stationary observers viewing the lights without the interference of an aircraft windscreen or of cockpit lights, and thus are not directly comparable to the threshold illuminances of Table VI [9]. However, it is believed that the ratio between threshold illuminances with intensity setting steps is applicable. Lefkowitz and Schlatter's data show that when the probability of seeing was 80%, the threshold illuminance applicable to runway lights for step 5 was about 10 times that for step 3 (the same ratio as that obtained from the NAFEC luminance measurements made for this study). * Thus, threshold illuminances of 10, 3 and 2 mile candles have been assumed as being applicable to a runway with HIRL, TDZL and RCLS operated on steps 5, 4 and 3, respectively.

Note that in computing these visual ranges no account has been taken of the additive intensity effect of adjacent lights in determining the intensity to be used. This effect would produce little or no increase when the visual range is less than 1000 feet and the increase would increase as the visual range increased.

The visual ranges given in Table VIII should not be considered to be definitive but to be illustrative only. Nevertheless, several significant conclusions may be drawn, namely:

- a. No significant increase in the visual range of approach lights will be obtained by increasing the intensity of the approach light system beyond step 3. (Although not shown in Table VIII, computations indicate that a small increase is obtained by going from step 2 to step 3.)
- b. The use of a threshold illuminance of 2 mile candles in computing visual ranges of approach lights will produce gross errors in the visual range when these lights are operated at full intensity.
- c. The increases in computed visual range of runway lights produced by going from step 3 to step 4 is small, and from step 4 to step 5, very small.
- d. Use of a threshold illuminance of 2 mile candles in computing RVR or visual ranges of runway lights will produce errors when these lights are operated on steps 4 and 5, which are of the same order of magnitude as would be obtained by using intensities which are 1.5 or 5 times the representative intensity of a light.

* Lefkowitz and Schlatter's data show that when the probability of seeing was 50%, the threshold illuminance for step 5 operations was about 5 times the threshold illuminance for step 3 operation.

3.2.2 Effects on the Glare Produced by the Lights

It is evident from the foregoing discussion that the background luminances produced by approach and runway lights not only increases the threshold illuminance but also increases the illuminance at which an individual light becomes glaring. Because of this increase and the presence of other bright lights in the system, the intensities required to produce troublesome glare from individual sources will be considerably higher than those shown in Table VI.

There are, however, two other troublesome effects frequently referred to as "glare." When the lights are operated at high intensity settings, the halation surrounding the lights will be much more visible and will produce a general fuzziness in the appearance of the system. In addition, the high background luminance levels of the approach zone raise the pilots' adaptation level and will reduce the visual range of the runway lights. This, plus the sudden decrease in background luminance as the visual segment passes out of the approach zone, will produce a "black-hole" effect. This effect is less pronounced when the background luminances are those corresponding to the flatter parts of the threshold illuminance curve of Figure 1.

4. HISTORICAL RÉSUMÉ OF INTENSITY SETTING CRITERIA IN THE U. S.

4.1 Early Criteria

During the period 1935 to 1940, neon approach light systems and runway edge lights were put into service at major airports. The neon approach lights were operated only at full intensity. Since the peak intensity of the neon lights was approximately 1000 candelas and since the lights were 72 inches long, the lights did not cause excessive glare when the viewing distance was short. There were, however, some complaints of the lights being too bright.

The runway edge lights (then called contact lights) were semiflush lights of low intensity. The type AN-L-9, the last in a series of these lights, had a peak intensity of approximately 800 candelas. Consequently, a large range of intensity control was not considered necessary. When intensity control was provided, the steps available were 50%, 100% and 150% of rated intensity. (The corresponding series-circuit currents were 6.0, 6.6, and 7.0 amperes.) It has been stated that a major airport of the period used the 150% setting in clear weather to provide better surface illumination of the runway edge and the 50% setting in haze and fog to reduce the glow around the lights.

The range of intensity settings was increased to 1%, 3%, 10%, 30% and 100% at the start of World War II to permit operation of these lights under blackout and restricted illumination conditions. [10] The same intensity settings were later used for the high intensity, elevated type D-1 lights when they were introduced for use as both approach and runway edge lights and continued to be used with the medium intensity type M-1 and with the high intensity type M-2 runway edge lights when these lights were introduced by the USAF. (Corresponding civil designations of these lights are L802 and L819, type 2.)

No reference to the applicable intensity setting criteria was located. However, specifications for instruction plates on the regulators of the period indicate that the criteria given in Table IX were applicable. [11]

Table IX
NIGHT-TIME INTENSITY SETTING CRITERIA
CIRCA 1943-1950

Visibility (miles)	Intensity-Setting	
	Step	%
Over 10	1	1
5 to 10	2	3
2 to 5	3	10
1 to 2	4	30
Less than 1	5	100

4.2 Air Force Night-time Intensity Setting Criteria, 1950-1968

Tests of the Landing Aids Experiment Station and field experience showed that approach lights and high intensity runway edge lights were annoyingly bright when operated at the 1% intensity setting in clear weather, and in the early 1950's the ratio between steps was changed to five to one yielding intensity settings of 0.16%, 0.8%, 4%, 20% and 100%. (See Section 5.2.2) Air Force intensity setting criteria of 1954 and 1958 using these new intensity steps are given in Table X. [12a, 12b] Note that the steps specified for approach lights in 1958 are one step lower than the 1954 steps for visibilities of $\frac{1}{2}$ mile and greater. During the 1950's the Air Force was using type C-1 (L819) runway edge lights and a center row (Configuration B) approach light system lamped with 200 watt lamps. A later order, AFM 60-5(C1) dated 29 April 1968 [12c] states that the ALS shall be operated on Step 3 at night when the visibility is 5 miles or less or when the ceiling is less than 2500 feet and on Step 1 at all other times. The intensity settings given for the HIRL in this order are those given in Appendix 1.

Table X. AIR FORCE NIGHT-TIME INTENSITY SETTING CRITERIA
OF 1954 AND 1958

Visibility Condition (miles)	Intensity Setting Step				Relative Intensity
	Approach Lights		Runway Edge Lights		
	1954	1958	1954	1958	
Greater than 3	2	1	1	1	0.16
1-3	3	2	2	2	0.8
$\frac{1}{2}$ -1	4	3	3	3	4
$\frac{1}{4}$ - $\frac{1}{2}$	4	4	4	4	20
Less than $\frac{1}{4}$	5	-	5	-	100

4.3 FAA Night-time Intensity Setting Criteria

Early CAA/FAA intensity setting criteria were not located. The earliest one located was prepared in 1958. [13] This order gives the same night-time intensity settings for the ALS and HIRL as those now in use and given in Appendix I. They are repeated in Table XI for convenience.

Table XI
FAA NIGHT-TIME INTENSITY SETTING CRITERIA FOR
THE ALS AND HIRL, 1968 TO DATE [13, 1]

Visibility Condition	Intensity Setting Step	
	Step	%
More than 3 miles 1 to 3 miles incl. Less than 1 mile	1	0.16
	2	0.8
	3	4
More than 5 3 to 5 incl. 1 to but not including 3 Less than 1	HIRL	
	1	0.16
	2	0.8
	3	4
	4	20

4.4 Night-time Intensity Setting Criteria for Touchdown Zone and Runway Center-line Lights

The Air Force instructions of 1968 [12c] give no intensity setting criteria for touchdown zone and centerline lights, presumably because the intensities of these lights ranged from about 60 candelas for the open strap lights to about 60,000 candelas for the Elfaka lights, stating only that "local procedures shall be established." FAA order 7110.8 [13] requires the intensity settings given in Table X for the HIRL and states that the touchdown zone and centerline lights be operated when the RVR is 4000 feet or less, the prevailing visibility is 3/4 mile or less, or as requested by the pilot. Present criteria [1] call for the intensity settings listed in Table X for the HIRL except where a Facility Directive specifies other settings to meet local conditions.

This exception is stated for all types of lights, as would be expected, and it is not known whether special attention is given to the differences in the intensities of TDZL and RCLS lights with intensities ranging from the 400 candelas for the type L842 to the 5000 candelas for the type L850A or B.

4.5 Night-time Intensity Setting Criteria for Medium Intensity Approach and Runway Lights

4.5.1 Runway Lights

Neither the FAA nor the Air Force orders of 1968 give intensity setting criteria for the MIRL. Regulator specifications [14] indicate that the criteria given in Table XII were used for Air Force medium intensity runway lights.

Table XII

AIR FORCE NIGHT-TIME INTENSITY SETTING CRITERIA
FOR MEDIUM INTENSITY RUNWAY LIGHTS

Visibility (miles)	Intensity Setting	
	Step	%*
Combat Operations	1	0.1
Combat Operations	2	0.7
Greater than 5	3	4.0
2-5	4	20
Less than 2	5	100

* Based upon use of 30W lamps.

Present FAA criteria for the MIRL are given in Table XIII. Although not stated in the FAA criteria, the criteria for the MIRL apply only to medium intensity runway lighting systems using type L802 fixtures and do not apply to systems using type L861 fixtures.

Table XIII

FAA NIGHT-TIME INTENSITY SETTING CRITERIA
FOR MIRL

Visibility (miles)	Intensity Setting	
	Step	%
Greater than 3	1	10
1-3	2	30
Less than 1	3	100

4.5.2 Approach Lights

FAA Publications of 1968 [13] and 1969 [15] do not give intensity setting criteria for the MALS. Current criteria are given in Table XIV.

Table XIV

FAA NIGHT-TIME INTENSITY SETTING CRITERIA
FOR THREE-STEP MALS*

Visibility (miles)	Intensity Setting	
	Step	%
3 or more	1	4
1 to but not including 3	2	20
Less than 1	3	100

* When used in a MALSR configuration.

The MALS was first used as an economical accompaniment to the low cost ILS. 120 volt lamps were used in multiple circuits and a cheap two step intensity control was obtained by operating the lamps at full and half voltage. This type operation could be obtained from a 120 volt circuit by using a commercial 240/120//120 volt transformer, without the use of a special regulator. Present intensity setting criteria for this system are given in Table XV. [1]

Table XV

FAA NIGHT-TIME INTENSITY SETTING CRITERIA
FOR TWO-STEP MALS*

Visibility	Intensity Setting			
	MALS		RAIL	
	Step	%		
3 miles or more	LOW	4	ON	100%
Less than 3 miles	HIGH	100	OFF	

* When used in a MALSR configuration.

5. STUDIES OF INTENSITY SETTING CRITERIA

5.1 Work of J. B. Bartow

The problem of adjusting the intensity of approach and runway lights was first given serious consideration by J. B. Bartow of Bartow Beacons, Inc. [16] in the late 1930's. Bartow proposed the use of a parallel row approach light system of high intensity projectors together with an elevated runway light system using the same type of projectors. The intensity distribution of these projectors was intended to make the illuminance at the eye of a pilot over the centerline the same for all lights in each row for all fog densities. The condition of uniform illuminance requires a beam pattern which changes with fog density. Bartow proposed to approximate the desired change in beam pattern by moving the lamps in the projectors laterally, thereby changing the angle of toe-in and the beam pattern. Lamp voltage was to be adjusted so that the illuminance at the pilot's eye was near threshold thereby minimizing the background brightness of the fog over the approach zone and runway.

Although the uniformity of illuminance at the pilot's eye achieved by using the Bartow principles was better, for a pilot over the centerline, than that achieved by any other system, the Bartow principles were found unsatisfactory in service because the electronic approach aids could not be flown with the accuracy required to make deviations of the aircraft from the centerline sufficiently small so that the principles of the design would be effective. [17, 18, 19]

5.2 National Bureau of Standards Tests and Studies

5.2.1 Nantucket and Indianapolis Tests

During the years 1939-1942 the National Bureau of Standards conducted a series of tests of approach and runway lights at the CAA Experimental Station, Indianapolis, and on Nantucket Island. The primary purpose of these tests was to determine whether the Bartow system of controlling and adjusting the illuminance from approach and runway lights would produce greater visual ranges in foggy weather than would a system of lights with fixed beams. [17] From this study it was determined that, because of the adaptability of the human eye, there is a ratio of about 1000 between the minimum and maximum illuminances. (See Appendix III).

These rating values were used in the determination of the optimum intensity of the lighting systems under observation as a function of fog density. The intensity of the system was adjusted to obtain the best appearance of the system considering the appearance of the nearer and farther lights of the system weighting the glare of the nearer lights

against the ease of seeing the more distant lights and noting the prevailing transmittance measured with the first NBS transmissometer.

The general formula obtained for the night observation is of the form

$$I'/I_0 = CT^{-d} \quad (2)$$

where

T is the prevailing transmissivity;

I_0 is the intensity of a light operated at full intensity;

I' is the optimum intensity at the transmissivity T ;

and

C and d are constants which depend upon the lighting system.

When the system is set at optimum intensity, the illuminance at a distance d from the pilot is given by Allard's law

$$E = I'T^d/d^2. \quad (3)$$

Combining equations (2) and (3) yields

$$E'_0 = I_0 C/d^2, \quad (4)$$

where E' is the illuminance at a fixed distance d when the system is set at optimum intensity. Note that T does not appear in equation (4). Since I_0 , C and d are constants, E' is a constant independent of the fog density.

Equation (4) provides a very important principle for controlling the intensity of an approach or runway light system at night; namely, maintain a selected illuminance at a suitable distance regardless of the transmissivity. When this is done, a light which is nearer to the pilot than the selected distance will appear brighter as the fog density increases and a light which is farther from the pilot than the selected distance will appear dimmer. The change in brightness increases as difference between the distance to a light and the selected distance increases.

The values of constants C and d are dependent upon such factors as the beam spread of the lights, their spacing, their offset from the runway axis, and the number of extraneous lights in the area.

5.2.2 Tests at the Landing Aids Experiment Station (LAES)

The validity of the principle developed from the Nantucket and Indianapolis studies was tested at LAES during 1948 and 1949 during tests of a method of photoelectric control of approach and runway lights developed by the National Bureau of Standards. [20, 21] The method of control is outlined in the block diagram of Figure 3.

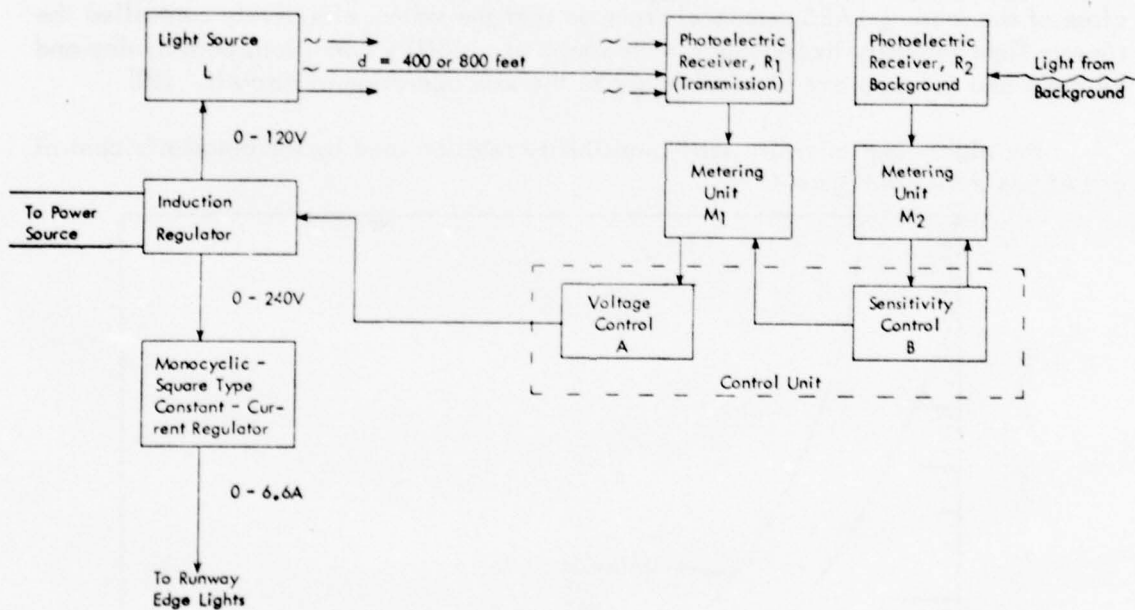

Figure 3. Block diagram of NBS Automatic Intensity Control System.

The light source L , fed from the lighting circuit, is placed at the selected distance d from a photoelectric receiver R_1 . The output from R_1 is sent to metering unit M_1 . This unit is linked electrically with A , the control unit mechanism of the lighting system in such a way that a change in the illuminance on R_1 , because of changing atmospheric transmissivity causes the control unit to drive an induction regulator supplying the lighting circuit so as to produce an equal and opposite change in the intensity of light L which is fed from the lines of the lighting system. Hence: the intensity of the lights of the system are also adjusted for the prevailing transmissivity. Receiver R_2 monitors the background luminance and through metering unit M_2 and sensitivity control unit B adjusts the sensitivity of M_1 to compensate for changes in background luminances ranging from night-time to daytime levels.

After preliminary tests in 1948, the automatic intensity control system was connected, in 1949, to control the intensity of the high intensity (type M-2) edge lights of runway 13-31 in all conditions of visibility and during night-time, twilight and daytime conditions. The selected distance was 400 feet. Detailed operational records, complete with several hundred pilot reports, were kept by LAES personnel. At the close of the season, LAES personnel reported that the system effectively controlled the runway light intensity throughout a wide range of visibility conditions both by day and by night and should prove a valuable aid to the safe operation of aircraft. [21]

The night-time intensity setting-visibility relation used by the automatic control at LAES is shown in Figure 4.

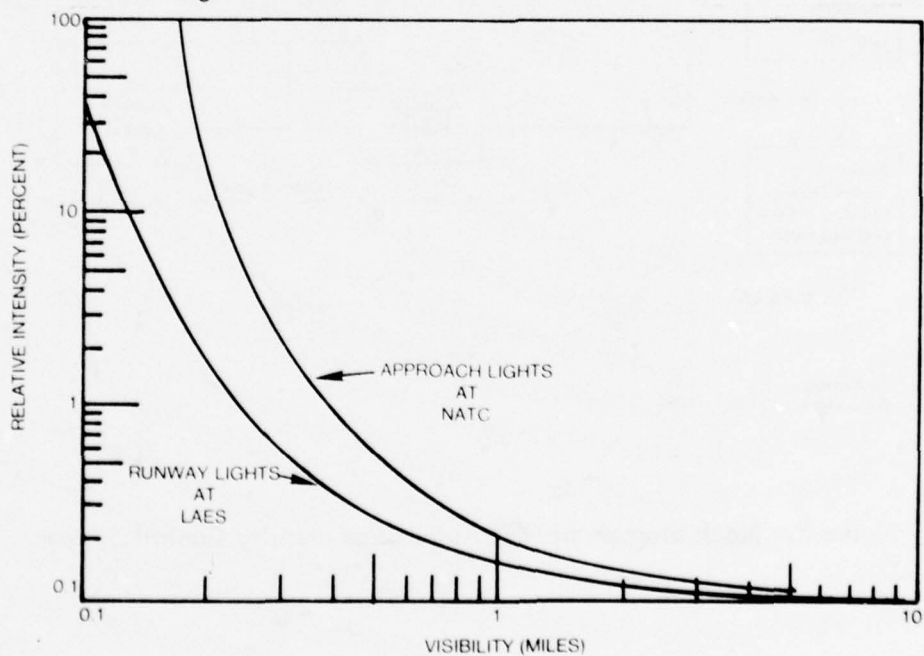

Figure 4. Night-time intensity settings obtained from NBS Automatic Intensity Control System

5.2.3 Tests at the Naval Air Test Center (NATC)

When the work at LAES was terminated in 1950, the automatic intensity control system was moved to the Naval Air Test Center, Patuxent River, Maryland, where it was connected to the power supply for the approach light systems being tested there. The selected distance was first 400 feet, as used at LAES. However, it was found that a greater increase in intensity was needed as the visibility decreased for the approach lights than had been required at LAES for the runway lights. The separation between the source and receiver was increased to 800 feet. The resulting visibility/intensity setting relation is also shown in Figure 4. Following this change the automatic control was found to provide better control than was obtained manually and that the intensity settings provided by the automatic control were lower than those used by the controllers. [22]

The intensity settings in candelas and percent intensity provided at LAES and NATC by the automatic control as a function of visibility read from the curves of Figure 4, are given in Table XVI.

Table XVI

NIGHT-TIME INTENSITY SETTINGS PROVIDED BY AUTOMATIC CONTROL AT LAES and NATC

Visibility (miles)	Intensity Settings			
	Approach Lights (NATC) (Candelas)	Relative Intensity (%)	Runway Edge Lights (LAES) (Candelas)	Relative Intensity (%)
3+	25	0.1	30	0.1
3	35	0.14	30	0.1
1	55	0.22	50	0.16
.5	170	0.6	75	0.25
.25	1400	5	300	1
.17	25000	100	900	3

Although its use was recommended, the automatic intensity control was never put into service because of the costs involved. However, the tests of the system provide the greatest amount of intensity setting data available. More than 400 test flights in all kinds of weather were made at LAES and over 100 test flights were made at NATC.

In considering Table XVI, the following factors should be noted.

The intensity distributions of the runway edge lights used at LAES and of the approach lights used at NATC did not differ significantly from the distributions of the present type L-819 runway lights and the present Q20A/PAR56 approach lights. Hence, the results of Table XVI may be compared directly with present intensity setting criteria.

The tests at LAES were restricted to runway edge lights only. The tests at NATC involved several approach light systems but did not involve the present ALS configuration.

The intensity settings for the visibility range 1/2 to 3 miles are considerably lower than those currently in use. This indicates that for this visibility range, at the time of the tests, the pilots were more concerned about the glare from the nearer lights than they were with extending the length of the visual segment.

The intensity settings of Table XVI for visibilities below 1/2 mile are higher than those in current use. For the approach lights this difference can be attributed, at least in part, to the differences between the configurations used during the tests and that of the ALS. None of the configurations tested at NATC had a concentration of lights on the centerline similar to that of the ALS. No rationale for the differences for the runway lights can be given.

The data of Table XVI are applicable to precision approaches only.

5.3 FAA Studies

5.3.1 Intensity Setting Criteria for Slope-Line Approach Light System

In a theoretical study of the visibility and glare ranges of the slope-line approach lights, Gilbert and Pearson developed optimum intensity setting criteria for these lights [23]. This study used as its basis the criterion developed during the Nantucket tests that glare begins to be experienced when the illuminance at the pilot's eye reaches a value of the order of 1000 times the threshold value (See Appendix III) and those intensity settings which would give the greatest possible intensity without glare on the glide path. The computed optimum intensity settings are given in Table XVII. The type 250 PAR56 approach light lamp was used in the slope-line system. The axial intensity is given in the table, not the representative intensity, as the authors used this intensity in computing the glare range.

Table XVII

OPTIMUM INTENSITY SETTINGS FOR
SLOPE-LINE APPROACH LIGHTS [23]

Visibility (miles)	Intensity Setting		
	Step	%	Candelas*
1/2	1	0.16	140
1/4	2	0.8	720
1/8	3	4	3600
1/16	5	100	90000

* Based upon a peak intensity of 90000 candelas for the 12.5 volt, 250 watt, type 250PAR lamp.

5.3.2 Intensity Setting Criteria Developed by the U. S. Advisory Committee on
Visual Aids to Approach and Landing

In 1971, the U. S. Advisory Committee on Visual Aids to Approach and Landing undertook a study of intensity setting criteria in preparation for the consideration of this subject at the Sixth Meeting of the Visual Aids Panel of ICAO. Under the direction of its Chairman, R. F. Gates of NAFEC, the Advisory Committee developed the night-time intensity setting criteria given in Table XVIII. [24]

Table XVIII

NIGHT-TIME INTENSITY SETTING CRITERIA
DEVELOPED BY U. S. ADVISORY COMMITTEE ON
VISUAL AIDS FOR APPROACH AND LANDING [24]

Visibility or RVR (miles/ft)	Light System							
	Approach		Runway Edge		Touchdown Zone		Centerline	
	Candelas*	Step	Candelas*	Step	Candelas*	Step	Candelas*	Step
More than 2 miles	220	2	130	2	50	2	40	2
More than 1 to 2 miles	1100	3	640	3	50	2	40	2
More than 2400 RVR to 1 mile	1100	3	640	3	240	3	200	3
1800 to 2400 RVR	1100	3	3200	4	240	3	200	3
1200 to 1600 RVR	5600	4	3200	4	1200	4	1000	4

* Based upon the representative intensities listed in Table III.

Operational tests of these settings were conducted for a 90-day period at 26 U.S. airports having runways equipped with ALS, MIRL, TDZL, and RCLS (See Appendix IV), and pilot remarks and requests relevant to these settings were obtained.

No formal report analyzing the data obtained from these tests was issued. The findings were summarized in a brief document prepared for the Sixth Meeting of the VAP. [25] The findings in that document relating to night-time intensities were:

- a. Approach lights: Step 1, 0.16% intensity, was requested and used "to a fair degree" when the visibility was above six miles.
- b. Runway edge lights: The proposed night-time settings were "well received."
- c. Touchdown zone lights: "The settings of the touchdown zone lights in visibilities of one mile or more appear to be too high and rechecking of the proposed settings may be required."
- d. Runway centerline lights: Lower settings were also requested for the centerline lights but not as frequently as they were for the touchdown zone lights at visibilities above two miles.

The document concludes with a statement that the experimental settings appear to be a considerable improvement over those then used in the U.S. However, no change has been made in U.S. intensity setting criteria. The findings of reference 25 appear to have been completely ignored.

5.4 Theoretical Study of Padmos and Vos

Padmos and Vos developed intensity setting criteria in a purely theoretical analysis based upon the effects of the lighting systems on the background luminance and hence the threshold illuminance of the pilot. [26] They show that for any given lighting system, or combination of systems, and fog density, a point is reached where further increases in intensity will produce no increase in visual range because the change in threshold illuminance with the increase in intensity completely counteracts the effects of change in intensity. The distance at which this point occurs is the maximum possible visual range for lights of the system under the given conditions of fog density. Padmos and Vos then use the intensity required to obtain nine tenths of this distance as the optimum intensity for the given condition of fog density. The intensity settings developed by this method are given in Table XIX.

Table XIX

NIGHT-TIME INTENSITY SETTINGS IN CANDELAS
DEVELOPED BY PADMOS and VOS [26]

RVR Meters (feet)	Light System				
	Approach	Approach Siderow	Runway Edge	Touchdown Zone	Centerline
>5000 (>17000)	300	100	600	130	200
1500-5000 (5000-17000)	300	100	600	200	200
800-1500 (2700-5000)	300	100	1000	400	300
400-800 (1300-2700)	300	100	1500	600	500
< 400 (<1300)	300	100	1500	800	500

Note that intensities are higher for conditions of good visibility and lower for conditions of low visibility than are those in current operational use.

The study is an excellent example of the power of theoretical analysis but, as noted by the authors, since it is based upon theoretical considerations, it should be considered only as a starting point.

5.5 Related Laboratory Studies

The glare criterion used by NPS, by Gilbert and Pearson, and (presumably) by LAES and NATC during their flight tests, was that of discomfort glare; that is, the lights were annoyingly bright but did not significantly interfere with the seeing of other lights. Thus, the term "glare" as used in this report refers to discomfort, not disability, glare.

In a recent study of discomfort glare produced by small sources, Bennett studies the effects of background luminance, source angle from the line of sight and source size. [27] The conditions of this test are so different from the operational use of approach and runway lights that a comparison of numerical values is not warranted. However, this test yields one very significant finding that is usually overlooked, namely, the enormous differences

between observers. Whereas, most studies use only a few observers, Bennett used a total of 97 college students as observers. He found that for one condition, the individual values of borderline between comfort and discomfort luminances covered a range of 20,000 to 1. The borderline comfort-discomfort level of the 75th percentile was 12 times that of the 25th percentile.

When these figures are considered, the range of intensities given in Table IV and the difficulties the VAP has encountered in reaching agreement on intensity setting criteria becomes less surprising.

In addition, a person is relatively insensitive to changes in intensity between adjacent lights in a system. Balder [28] found that deviation in intensity between 0.7 and 1.3 times the normal intensity were not noticed in more than 90% of his observations. Deviations between 0.6 and 1.5 times the nominal intensity were not noticed in more than 75% of the observations. Deviations between 0.4 and 2.1 times the nominal intensity were considered unacceptable in less than 15% of the observations.

In Balder's study there were adjacent lights which provided a base for comparison. When the intensity of all the lights of the system are changed, there is no such base, and the tolerances to changes in the intensity of a complete system would be even greater than those found by Balder.

Inagaki has studied the illuminances required of signal lights used as aids to marine navigation by means of a model. [29] The effects of background luminances and backgrounds of city lights were considered. The lights were evaluated visually into five rating categories (just visible, dark, proper, bright, and glaring) in a manner very similar to that used by NBS nearly forty years earlier. (See Appendix III)

Inagaki found that the environmental background luminances ranged from 10^{-4} to 10^{-1} cd/m^2 (3×10^{-5} to 3×10^{-2} footlamberts) and that typically the illuminance for a given rating category increased by a factor of about three in going from the lowest to the highest background luminance. The "just visible" illuminance was of the order of 5×10^{-7} lux (1.4 mile candle), a value very close to the night-time RVR threshold illuminance of two mile candles. The "proper" illuminance was of the order of 10^{-4} lux (280 mile candles), whereas, the "adjusted" illuminance for the "satisfactory" category of the Nantucket tests was 120 mile candles. Inagaki found an illuminance of the order of 3×10^{-3} lux (8,000 mile candles) to be "glaring". The corresponding value from the "adjusted" Nantucket study was 2,000 mile candles. Inagaki found the ratio between "glaring" and "just visible" to be of the order of 6,000; whereas, a value of about 1,000 was obtained at Nantucket and as currently used in aviation design practice.

In view of the large individual differences found by Bennett, the relatively small differences between the illuminance values of Inagaki and those of the Nantucket study are pleasantly surprising.

5.6 Summary of Night-time Intensity Criteria

Pertinent night-time intensity setting practices are summarized in Table XX. Since the break points used in the several practices are different, the intensities to be used for specific visibility conditions are shown instead of the visibility ranges corresponding to the intensity settings.

Table XX

-a-

SUMMARY OF NIGHT-TIME INTENSITY SETTING PRACTICES FOR HIGH INTENSITY APPROACH LIGHTS

Organization →	Recommended Intensity (Candelas)				U. S. Advisory Committee
	FAA 7110.65A	VAP*	NBS/NATC	Podmos & Vos	
Visibility (miles)					
Greater than 5	45	OFF-400	25	300**	220
5	45	OFF-400	25	300	220
4	45	OFF-400	25	300	220
3	220	300-2000	35	300	220
2.5	220	300-2000	40	300	220
2	220	300-2000	45	300	1100
1 (or 6000 ft RVR)	220	800-5000	55	300	1100
1/2 (or 3000 ft RVR)	1100	800-5000	170	300	1100
1/4 (or 1600 ft RVR)	1100	2000-20000	1400	300	5600
900 ft (or 1200 ft RVR)	1100	2000-20000	25000	300	5600
Less than 900' (or 1200 ft RVR)	1100	2500-20000	25000	300	--

* Listed only, not recommended.
** 100 candelas for approach light side rows.

-b-

SUMMARY OF NIGHT-TIME INTENSITY SETTING PRACTICES FOR HIGH INTENSITY RUNWAY EDGE LIGHTS

Organization →	Recommended Intensities (Candelas)				U. S. Advisory Committee
	FAA 7110.65A	VAP*	NBS/LAES	Podmos & Vos	
Visibility (miles)					
Greater than 5	26	30-300	30	600	130
5	130	30-300	30	600	130
4	130	30-300	30	600	130
3	130	100-1000	30	600	130
2.5	640	100-1000	35	600	130
2	640	100-1000	40	600	640
1 (or 6000 ft RVR)	640	600-3000	50	600	640
1/2 (or 3000 ft RVR)	3200	600-3000	75	1000	640
1/4 (or 1600 ft RVR)	3200	1000-10000	300	1500	3200
900 ft (or 1200 ft RVR)	3200	1000-10000	900	1500	3200
Less than 900 ft (or 1200 ft RVR)	3200	4000-10000	9000**	1500	--

* Listed only, not recommended.
** At 700 ft visibility, 900 ft RVR.

-c-

SUMMARY OF INTENSITY SETTING PRACTICES FOR TOUCHDOWN ZONE LIGHTS

Organization →	Recommended Intensities (Candelas)			U. S. Advisory Committee
	FAA 7110.65A	VAP*	Podmos & Vos	
Visibility (miles)				
Greater than 5	10	10-100	130	50
5	50	10-100	130	50
4	50	10-100	130	50
3	50	50-500	200	50
2.5	240	50-500	200	50
2	240	50-500	200	50
1 (or 6000 ft RVR)	240	250-1500	200	240
0.5 (or 3000 ft RVR)	1200	250-1500	400	240
0.25 (or 1600 ft RVR)	1200	500-5000	600	1200
900 ft (or 1200 ft RVR)	1200	500-5000	800	1200
Less than 900 ft (or 1200 ft RVR)	1200	600-5000	800	--

* Listed only, not recommended.

-d-

SUMMARY OF INTENSITY SETTING PRACTICES FOR RUNWAY CENTERLINE LIGHTS (50-ft SPACING)

Organization →	Recommended Intensities (Candelas)			U. S. Advisory Committee
	FAA 7110.65A	VAP*	Podmos & Vos	
Visibility (miles)				
Greater than 5	8	10-100	200	40
5	40	10-100	200	40
4	40	10-100	200	40
3	40	40-300	200	40
2.5	200	40-300	200	40
2	200	40-300	200	40
1 (or 6000 ft RVR)	200	200-1000	200	200
0.5 (or 3000 ft RVR)	1000	200-1000	300	200
0.25 (or 1600 ft RVR)	1000	200-1500	500	1000
900 ft (or 1200 ft RVR)	1000	200-1500	500	1000
Less than 900 ft (or 1200 ft RVR)	1000	600-2500	500	--

* Listed only, not recommended.

The following should be noted from Table XX.

a. The visibility conditions of 3 miles and lower, the upper limits of the ranges of intensities listed by the VAP are greater, and in many instances much greater, than the intensities listed under any of the other methods for the corresponding visibility.

b. For visibilities above 3 miles, the intensities listed under Padmos and Vos and the intensity of the upper VAP limit are comparable. Intensities listed under all other methods are lower.

c. Some of the intensities listed for approach lights under FAA Publication 7110.65A are lower than the intensities of the lower VAP limit for the corresponding visibility, although the VAP listings supposedly include U.S. practice.

d. The intensities listed for approach lights and runway edge lights under the method labeled NBS are lower, often much lower, than the intensities listed for the corresponding visibility under all other methods when the visibility is 0.5 mile or more.

5.7 Recommended Night-time Intensity Setting Criteria

5.7.1 Recommended Night-time Intensity Setting Criteria for Steady Burning, High Intensity Light Systems

As is evident from the preceding discussion, there is no unequivocal method of obtaining optimum intensity settings. Therefore, the intensity settings recommended in Table XXI are only the engineering judgments of the author based upon the foregoing discussions.

Table XXI

RECOMMENDED NIGHT-TIME INTENSITY SETTINGS
FOR STEADY BURNING, HIGH INTENSITY LIGHT SYSTEMS

System → Visibility Range (miles)	ALS		HIRL		TDZL		RCLS	
	Intensity (Candelas)	Step	Intensity (Candelas)	Step	Intensity (Candelas)	Step	Intensity (Candelas)	Step
Greater than 5	45	1	26	1	10	1	8	1
Greater than 1 to and including 5	220	2	130	2	50	2	40	2
1/4 to 1* incl.	1100	3	640	3	240	3	200	3
Less than 1/4**	1100	3	3200	4	240	3	200	3

* or 1200 feet RVR to and including 6000 ft RVR.

** or less than 1200 feet RVR.

In making these judgments, special consideration was given to the following conclusions:

a. ALS - There is no significant gain in visual range when the approach lights are operated on steps 4 or 5 over that obtained with step 3 operation. (See Table VIII)

b. The tests conducted for the U.S. Advisory Committee indicated that Step 1 was preferable to Step 2 in conditions of good visibility. (See Section 5.3.2)

c. HIRL - In order for the RVR system to be operative under conditions of 1 mile visibility, or 6000 ft RVR, this system must be operated on Step 3 or higher step. This system can be operated on Step 4 when the TDZL and RCLS are on Step 3 without significantly increasing the luminance of the fog over the runway.

d. TDZL and RCLS - In order to maintain a "balanced" system, these systems should be operated on the same intensity step as the HIRL. An exception was made for very low visibilities because the difficulty in seeing the HIRL under this condition is believed to warrant Step 4 operation. However, it is believed that Step 4 operation of the TDZL and RCLS would produce annoying glare under this condition.

Table XXII has been prepared to provide a convenient means of comparing the intensity settings recommended in this report with those listed in FAA Publication 7110.65A and those recommended by the U.S. Advisory Committee.

Table XXII

COMPARISON OF RECOMMENDED NIGHT-TIME INTENSITY SETTING CRITERIA,
PRESENT U. S. PRACTICE AND ADVISORY COMMITTEE PROPOSAL

a. Intensity Setting Steps

System		ALS			HIRL			TDZL			RCLS		
Method		7110.65	U. S. Advisory Com.	Recommended this Report	7110.65	U. S. Advisory Com.	Recommended this Report	7110.65	U. S. Advisory Com.	Recommended this Report	7110.65	U. S. Advisory Com.	Recommended this Report
RVR (feet)	Visibility (miles)												
	Greater than 5	1	2	<u>1</u>	1	2	<u>1</u>	1	2	<u>1</u>	1	2	<u>1</u>
	5	1	2	<u>2</u>	2	2	<u>2</u>	2	2	<u>2</u>	2	2	<u>2</u>
	4	1	2	<u>2</u>	2	2	<u>2</u>	2	2	<u>2</u>	2	2	<u>2</u>
	3	2	2	<u>2</u>	2	2	<u>2</u>	2	2	<u>2</u>	2	2	<u>2</u>
	2	2	3	<u>2</u>	3	3	<u>2</u>	3	2	<u>2</u>	3	2	<u>2</u>
6000	1	2	3	<u>3</u>	3	3	<u>3</u>	3	3	<u>3</u>	3	3	<u>3</u>
3000	1/2	3	3	<u>3</u>	4	3	<u>3</u>	4	3	<u>3</u>	4	3	<u>3</u>
1600	1/4	3	4	<u>3</u>	4	4	<u>3</u>	4	4	<u>3</u>	4	4	<u>3</u>
800	1/8	3	-	<u>3</u>	4	-	<u>4</u>	4	-	<u>3</u>	4	-	<u>3</u>
Less than 800	Less than 1/8	3	-	<u>3</u>	4	-	<u>4</u>	4	-	<u>3</u>	4	-	<u>3</u>

b. Representative Intensities (Candelas)

System		ALS			HIRL			TDZL			RCLS		
Method		7110.65	U. S. Advisory Com.	Recommended this Report	7110.65	U. S. Advisory Com.	Recommended this Report	7110.65	U. S. Advisory Com.	Recommended this Report	7110.65	U. S. Advisory Com.	Recommended this Report
RVR (feet)	Visibility (miles)												
	Greater than 5	45	220	<u>45</u>	26	130	<u>26</u>	10	50	<u>10</u>	8	40	<u>8</u>
	5	45	220	<u>220</u>	130	130	<u>130</u>	50	50	<u>50</u>	40	40	<u>40</u>
	4	45	220	<u>220</u>	130	130	<u>130</u>	50	50	<u>50</u>	40	40	<u>40</u>
	3	220	220	<u>220</u>	130	130	<u>130</u>	50	50	<u>50</u>	40	40	<u>40</u>
	2	220	1100	<u>220</u>	640	640	<u>130</u>	240	50	<u>50</u>	200	40	<u>40</u>
6000	1	220	1100	<u>1100</u>	640	640	<u>640</u>	240	240	<u>240</u>	200	200	<u>200</u>
3000	1/2	1100	1100	<u>1100</u>	3200	640	<u>640</u>	240	240	<u>240</u>	1000	200	<u>200</u>
1600	1/4	1100	5600	<u>1100</u>	3200	3200	<u>640</u>	240	1200	<u>240</u>	1000	1000	<u>200</u>
800	1/8	1100	--	<u>1100</u>	3200	--	<u>3200</u>	1200	--	<u>240</u>	1000	--	<u>200</u>
Less than 800	Less than 1/8	1100	--	<u>1100</u>	3200	--	<u>3200</u>	1200	--	<u>240</u>	1000	--	<u>200</u>

5.7.2 Recommended Night-time Intensity Setting Criteria for Steady Burning Medium Intensity Approach and Runway Light Systems

No studies or other considerations regarding intensity setting criteria applicable to the MALS or MIRL were located in the literature. Such studies as exist were confined to high intensity systems.

There is no apparent reason why the intensity settings of the MALS and MIRL should not provide, insofar as practicable, the recommended intensities listed in Table XXIb for the various visibility conditions. Although, at first thought, it would seem that since the barrettes of the MALS are spaced at 200 foot intervals, instead of the 100 foot intervals of the ALS, the background luminances of the MALS would be about one half that of the ALS for a given candela output. However, the lamps used in the MALS are much less efficient in generating a beam than are those of the ALS. Computation indicates that this inefficiency compensates approximately for the difference in spacing and that there is no significant difference in the background luminance per candela.* Hence, no change in intensity is warranted.

The intensity settings recommended for the MALS are given in Table XXIII. These settings have been chosen, insofar as the limitations of the circuitry permits, to be consistent with the intensities given in Table XXI for the ALS.

Table XXIII
RECOMMENDED INTENSITY NIGHT-TIME SETTINGS FOR
STEADY BURNING, MEDIUM INTENSITY LIGHT SYSTEMS

Visibility Range (miles)	3-Step MALS		2-Step MALS		MIRL			
	Intensity (Candelas)		Intensity (Candelas)		Type L802		Type L861	
	Step	Step	Step	Step	Intensity (Candelas)	Step	Intensity (Candelas)	Step
More than 1	240	1	240	LOW	250	1	125	3
3/4 to 1 incl.	1200	2	6000	HIGH	750	2	125	3
Less than 3/4	1200	2	6000	HIGH	2500	3	125	3

* The inner 1400 feet of the ALS, when operated at full current, radiates roughly four times the lumens radiated by the MALS operated at full voltage. However, as shown in Table III, the representative intensity of the lights of the ALS is roughly four times that of the MALS. Thus, when the two systems are operated so as to produce equal candlepower, the lumen outputs of the two 1400 foot lengths of approach lights will be roughly equal. Hence, the background luminances will also be roughly equal.

A comparison of these settings with present practice and that recommended for the ALS is given in Table XXIV. Note that it is not possible to obtain as low an intensity as desired for use in clear weather. Note also that it is not possible to obtain a suitable intensity from the 2-Step MALS for use in 1 mile visibility conditions.

Table XXIV. COMPARISON OF RECOMMENDED NIGHT-TIME INTENSITY SETTING CRITERIA FOR MEDIUM INTENSITY APPROACH LIGHT SYSTEMS AND PRESENT U. S. PRACTICE

System → Method → Visibility (miles)	3-Step MALS				2-Step MALS				Recommended for ALS in Table XXI Intensity (Candelas)
	7110.65A		Recommended		7110.65A		Recommended		
	Step	Intensity (Candelas)	Step	Intensity (Candelas)	Step	Intensity (Candelas)	Step	Intensity (Candelas)	
Greater than 5	1	240	<u>1</u>	<u>240</u>	LOW	240	<u>LOW</u>	<u>240</u>	45
5	1	240	<u>1</u>	<u>240</u>	LOW	240	<u>LOW</u>	<u>240</u>	220
4	1	240	<u>1</u>	<u>240</u>	LOW	240	<u>LOW</u>	<u>240</u>	220
3	1	240	<u>1</u>	<u>240</u>	LOW	240	<u>LOW</u>	<u>240</u>	220
2	2	1200	<u>1</u>	<u>240</u>	HIGH	6000	<u>LOW</u>	<u>240</u>	220
1 (or 6000 ft RVR)	2	1200	<u>2</u>	<u>1200</u>	HIGH	6000	<u>HIGH</u>	<u>6000</u>	1100
Less than 1	3	6000	<u>2</u>	<u>1200</u>	HIGH	6000	<u>HIGH</u>	<u>6000</u>	1100

A similar comparison for the type L802 MIRL is given in Table XXV. Note that the minimum intensity obtainable for this MIRL is somewhat higher than desired. Note also that the intensity recommended for this MIRL for $\frac{1}{2}$ mile visibility is about four times that recommended for the HIRL. This higher intensity was recommended as the MIRL will seldom be used with an RCLS and because the horizontal beam spread of the lights of the MIRL is somewhat narrower than desired. The higher intensity will increase the coverage at the risk of increased glare.

Table XXV

COMPARISON OF RECOMMENDED NIGHT-TIME INTENSITY SETTINGS
FOR MEDIUM INTENSITY RUNWAY LIGHTS USING TYPE L802 LIGHTS
AND PRESENT PRACTICE

Method → Visibility (miles)	7110.65A		Recommended		Recommended for HIRL in Table XXI Intensity (Candelas)
	Step	Intensity (Candelas)	Step	Intensity (Candelas)	
Greater than 5	1	250	<u>1</u>	<u>250</u>	26
5	1	250	<u>1</u>	<u>250</u>	130
4	1	250	<u>1</u>	<u>250</u>	130
3	2	750	<u>1</u>	<u>250</u>	130
2	2	750	<u>1</u>	<u>250</u>	130
1	2	750	<u>2</u>	<u>750</u>	640
1/2	3	2500	<u>3</u>	<u>2500</u>	640

5.8 Intensity Setting Criteria for Sequenced Flashers

The sequenced flashers installed as a part of most high intensity approach lighting systems now have no provision for intensity control. (However, these fixtures are being replaced with fixtures having intensity control as the towers of these systems are being replaced with frangible towers.) They are operated at full intensity when the associated ALS is operating and the ceiling is less than 1000 feet or the visibility less than 3 miles. [1] With this type of operation the sequenced flashers often produce annoying glare and are turned off at the request of the pilot at some point during his final approach.

Intensity control of flashers was developed by Weinstein as part of the MALSR development. [30] Weinstein related the intensities of the sequenced flashers to those of the HIRL as shown in Table XXVI. Sequenced flashers with intensity control are now being used in the MALSR with their control circuits interconnected with the MALSR control circuits so that the two systems are operated on the same intensity setting step.

Table XXVI

INTENSITY CONTROL OF FLASHERS [30]

HIRL Step	Flashers	
	Step	Intensity (Candelas)
5	HIGH	14000
3	MEDIUM	4000 or 1200
2	LOW	130

The latest FAA Specification of sequenced flashing lights provides for 3 step intensity control for all newly installed sequenced flashers with nominal intensities of 300, 1400 and 14,000 candelas (2%, 10% and 100%) for steps 1, 2 and 3, respectively. [31]

The only available data upon which to base the intensity setting criteria for the sequenced flashers are the results of the flight tests reported by Weinstein. [30] The relations between the intensity setting steps of the ALS, or the MALS, and the sequenced flashers given in Table XXVII are based upon these data. These criteria appear to be satisfactory and their continued use is recommended.

Table XXVII

RELATION BETWEEN INTENSITY SETTINGS
OF THE ALS AND THE MALS
AND THE SEQUENCED FLASHERS

ALS		Sequenced Flashers	
Step	Intensity (Candelas)	Step	Effective Intensity* (Candelas)
1	45]	1	300
2	220]		
3	1100	2	1400
4	5600]	3	14000
5	28000]		
MALS			
1	240	1	300
2	1200	2	1400
3	6000	3	14000

* Based upon Specification FAA-E-2628a.

5.9 "Simplified" Approach Light Systems

The intensity setting criteria recommended for the ALS are applicable to the "simplified" approach light systems (SSALS, SALSF and SALSr) as well as to the ALSF-1 and the ALSF-2. FAA Publication 7110.65A [1] makes no specific reference to these systems. Handbook 6850.2 [2] indicates that the only intensity steps required are the 100%, 20% and 4% steps but that all five intensity steps "may be used if available." In the author's opinion, providing only a 3-step control for these systems is a grave error since doing so will require that these "simplified" systems will be operated at an intensity of 1100 candelas for all visibilities greater than 1 mile. The full 5 step intensity control is required for these systems.

5.10 An Alternate Intensity Control Procedure

An intensity setting procedure which has been used to advantage in the U. S. and abroad during periods of low ceilings and moderately restricted visibility is that of operating the approach lights (and in some instances, the runway lights) at full intensity until the pilot requests dimming. This procedure was endorsed by the member of the Visual Aids Panel nominated by the International Federation of Airline Pilots Associations who cautioned that the pilot should be alerted to the procedure and that it is suitable only at sophisticated airports where the efficiency of the controllers is high and there are no language difficulties. [32] At night, the glow from lighting systems operating at full intensity will usually be visible at a height of about 50 feet above the cloud base, thus providing earlier awareness of the approach lights. (A similar advantage is obtained in the approach light systems using sequenced flashers which do not have provision for dimming and, hence, are operated at 100% intensity in these weather conditions.)

6. OPTIMUM DAYTIME INTENSITY SETTING CRITERIA

6.1 Theoretical Considerations

Developing the optimum intensity setting criteria for daylight presents few problems. The daytime threshold illuminance used in the U. S. for RVR computations is 1000 mile candles, 500 times the night-time threshold illuminance. Thus, the intensities which would cause the nearest lights to become glaring are expected to be about 500 times the intensities listed in Table VI. Thus, when these lights are operated at 100% intensity, the intensities of the near lights are only slightly above the "glaring" intensity. Thus, the problem of determining optimum intensity setting criteria is primarily a problem of determining intensities which will provide adequate visual guidance.

The intensity required of a light to provide a visual range equal to the prevailing daylight (meteorological) visibility is, assuming a daylight threshold illuminance of 1000 mile candles and a threshold contrast of 0.05, given by equation (5).*

$$I_v = 20,000 V_m^2 \quad (5)$$

where

I_v is the intensity of a light having a visual range equal to the meteorological visibility, and

V_m is the daytime visibility in miles.

Thus, an intensity of 20,000 candelas is required when the visibility is 1 mile, and the intensity required increases rapidly as the visibility increases.

The condition under which the visual ranges of the lights of the several lighting systems are equal to the visibility is given by

$$D = \sqrt{I/20,000} \quad (6)$$

where

I is the intensity of the light under consideration, and

D is the visual range of the light and the visibility.

The results of the computations are given in Table XXVIII.

* See Appendix II.

Table XXVIII

CONDITIONS UNDER WHICH THE VISUAL RANGE OF APPROACH
AND RUNWAY LIGHTS IS EQUAL TO THE DAYTIME
(METEOROLOGICAL) VISIBILITY

Light	Intensity (Candelas)	Visual Range and (Meteorological) Visibility	
		(miles)	(feet)
ALS	28,000	1.2	6200
HIRL	16,000	0.9	4700
TDZL	6,000	0.55	2900
RCLS	5,000	0.5	2640
MALS	6,000	0.55	2900
MIRL	2,500	0.35	1870
SFL	14,000	0.8	4400

It is evident from this table that the visual ranges of the several lighting systems are less than the visibility unless the visibility is low, even though these lights are operating at full intensity.

However, for reasons given below, the visual range of the runway and the runway surface markings is usually less, and often much less, than the visibility. Thus, the lighting systems can provide very useful guidance even when their visual ranges are less than the visibility.

Since the runway and the runway surface markings are not viewed against a sky or fog background, their visual range cannot be computed from Koschmieder's Law. The theory of the visual range of an object viewed against an immediate terrestrial background was developed by Duntley [33]. In 1953, Douglas applied this theory to the problems of visibility from aircraft [34]. In his analysis he found that the visual range of such targets as the runway or its surface markings was of the order of 0.3 to 0.6 of the visibility under overcast conditions, and the visibility factor could go to 0.1 or lower under low, up-sun, haze or thin cloud conditions. See Appendix V for further details.

If visual range were the only criterion, during daylight the approach and runway lights would be operated at full intensity at all times. However, in the interest of

extending lamp life and energy conservation, operation at a reduced intensity is desirable if an adequate visual range will be provided at the reduced intensity.

A visual range of one mile for the approach and runway lights is taken as adequate in this study.

When the visual range required of the light differs from the meteorological visibility the required intensity is given by equation (7). *

$$I = 1000 V^2 / 0.05 (V/V_m) \quad (7)$$

where

V_m is the (meteorological) visibility, and

V is the desired visual range.

The intensity required to give a visual range of 1 mile as a function of meteorological visibility is given in Table XXIX.

Table XXIX

INTENSITY (IN CANDELAS) REQUIRED OF A LIGHT TO
PRODUCE A VISUAL RANGE OF ONE MILE

Meteorological Visibility (miles)	Intensity (Candelas)	Required Intensity Setting Step for ALS and HIRL
10	1350	3
5	1800	4
3	2700	4
2	4500	5
1.5	7400	5
1	20000	5

* See Appendix II.

As is evident from equation (5), the intensity required to produce a visual range equal to the meteorological visibility decreases significantly as the visibility decreases. At very low visibilities the visual range of lights of all lighting systems exceeds the visibility when the lights are operated at full intensity. This effect is shown in Table XXX.

Table XXX

VISUAL RANGE (IN FEET) OF APPROACH AND RUNWAY LIGHTS OPERATING AT FULL INTENSITY DURING CONDITIONS OF LOW VISIBILITY

System →	Visibility*		t250	ALS	HIRL	TDZL	RCLS
	(miles)	(feet)					
	3/4	3960	0.83	4700	4300	3500	3300
	1/2	2640	.75	3600	3300	2700	2600
	1/4	1320	.56	2200	2100	1760	1700
	1/8	660	.32	1340	1250	1090	1060

* Based upon a threshold contrast of 0.05.

6.2 Recommended Daytime Intensity Setting Criteria

Recommendations of daytime intensity setting criteria based upon the foregoing analysis are given in Table XXXI.

Table XXXI

RECOMMENDED DAYTIME INTENSITY SETTING CRITERIA
FOR STEADY BURNING LIGHTS

Visibility Range (miles)	Light System							
	Step	ALS Intensity (Candelas)	Step	HIRL Intensity (Candelas)	Step	TDZL Intensity (Candelas)	Step	RCLS Intensity (Candelas)
Greater than 5	3*	1100	3*	640	4*	1200	4*	1000
3 to 5 incl	4*	5600	4*	3200	4*	1200	4*	1000
Less than 3	5	28000	5	16000	5	6000	5	5000
		<u>MALS</u>		<u>MIRL**</u>				
3 to 5 incl	3 or HIGH*	6000	3*	2500				
Less than 3	3 or HIGH	6000	3	2500				

* To be used when approaches are being made into a low sun, at all times less than 30 minutes before sunset or after sunrise, and upon pilot request.

** For systems using Type L802 lights.

A comparison of the recommended intensity setting criteria and present practice is given in Table XXXII.

Table XXXII. COMPARISON OF RECOMMENDED DAYTIME INTENSITY SETTING CRITERIA WITH PRESENT U. S. PRACTICE AND ADVISORY COMMITTEE PROPOSAL

a. Intensity Setting Steps

Light Systems Visibility (miles)	ALS			HIRL			TDZL & RCLS		
	7110.65A	Advisory Committee	Recom- mended	Present Practice	Advisory Committee	Recom- mended	Present Practice	Advisory Committee	Recom- mended
Greater than 5	1	**	3 ⁺	**	**	3 ⁺	**	**	4 ⁺
5	3	**	4 ⁺	**	**	4 ⁺	**	**	4 ⁺
4	3	**	4 ⁺	**	**	4 ⁺	**	**	4 ⁺
3	3 ⁺	4	4 ⁺	**	4	4 ⁺	**	3	4 ⁺
2	4	4	5	4	4	5	4	4	5
1	5	5	5	4	5	5	4	5	5
Less than 1	5	5	5	5	5	5	5	5	5

	MAIS - 3 Step			MAIS - 2 Step			MIRL++		
Greater than 5	**	-	3 ⁺	**	-	HIGH ⁺	**	-	3 ⁺
5	**	-	4 ⁺	**	-	HIGH ⁺	**	-	3 ⁺
4	**	-	4 ⁺	**	-	HIGH ⁺	**	-	3 ⁺
3	**	-	4 ⁺	**	-	HIGH ⁺	2	-	3 ⁺
2	2	-	5	HIGH	-	HIGH	2	-	3
1	3	-	5	HIGH	-	HIGH	3	-	3

b. Intensities (Candelas)

Light Systems Visibility (miles)	ALS			HIRL			Present Practice		
	7110.65A	Advisory Committee	Recom- mended	Present Practice	Advisory Committee	Recom- mended	Present Practice	Advisory Committee	Recom- mended
Greater than 5	45	**	1100 ⁺	**	**	640 ⁺	**	**	1200 1000 ⁺
5	1100	**	5600 ⁺	**	**	3200 ⁺	**	**	1200 1000 ⁺
4	1100	**	5600 ⁺	**	**	3200 ⁺	**	**	1200 1000 ⁺
3	1100	5600	5600 ⁺	**	3200	3200 ⁺	**	240 200	1200 1000 ⁺
2	5600	5600	28000	3200	3200	16000	1200 1000	1200 1000	6000 5000
1	28000	28000	28000	3200	16000	16000	1200 1000	6000 5000	6000 5000
Less than 1	28000	28000	28000	16000	16000	16000	6000 5000	6000 5000	6000 5000

	MAIS			MIRL++		
5	**		6000 ⁺	**		2500 ⁺
4	**		6000 ⁺	**		2500 ⁺
3	**		6000 ⁺	**		2500 ⁺
2	1200		6000	500		2500
1	6000		6000	2500		2500

* Present Table 460 of Publication 7110.65 is not clear. Steps 3 and 4 are both listed for 3 mile visibility.

** When requested.

+ To be used when approaches are being made into a low sun, at all times less than 30 minutes before sunset and after sunrise, and upon pilot request.

++ For systems using type L802 lights.

The intensities of Table XXXII corresponding to the intensity settings of Table XXXI were obtained from the relative intensity-current relations of reference 3 using the representative intensities listed in Table III.*

Note that the recommended intensity setting criteria for the high intensity systems call for considerably more operation at Steps 4 and 5 than does present practice. In considering the effect of this upon lamp life, it should be noted that the calculated life of lamps operating on Step 4 (20% intensity) is about 500 times the rated life.

Because of the relatively low intensities of the MALS and the MIRL, operation only at full intensity is recommended.

7. INTENSITY SETTING CRITERIA FOR TWILIGHT

Little consideration has been given to the optimum intensity setting criteria for operation during twilight conditions. The only reference to twilight operation found in the review of the literature (except for descriptions of the NBS automatic intensity control system which automatically provided a smooth transition between day and night operation) was a note in Section 1050 of Publication 7110.65A [1] which allows an exception to the listed intensity setting criteria "when facility directives specify other settings to meet local atmospheric, topographic and twilight conditions." Yet it is obvious that there should be a smooth transition between the daytime and night-time intensity settings, not a sudden jump.

To provide this transition, it is recommended that the lights be operated one step below the steps listed in Table XXXI during the periods extending from sunset to 30 minutes after sunset and from 30 minutes before sunrise to sunrise.

* Appendix II contains an explanation of the meaning and application of the "representative intensity" concept.

8. DISCUSSION OF RECOMMENDED INTENSITY SETTING CRITERIA

8.1 Restrictions to Application

The intensity setting criteria recommended in Tables XXI and XXXI are applicable only to lighting systems using fittings having the lamp types and representative intensities listed in Table III and regulators having output currents listed in Advisory Circular AC 150/5345-10C [35] for high intensity lights, in Advisory Circular AC 150/5345-11 [36] for medium intensity runway lights, and in Specifications FAA-E-2325A, B or C, and FAA-E-2700 for the MALS. [37]

Whenever there is a variance in equipment, the intensities of the lights of the system should be checked against the intensities listed in Tables XXI and XXXI and any necessary adjustments in intensity setting steps made.

The recommended intensity setting criteria are based upon the assumption that the aircraft will be using precision approach electronic aids or other guidance which will bring the aircraft into the beam of the lights. The off-runway intensities of neither the approach lights nor the runway lights are high enough to provide circling guidance when they are dimmed to prevent glare from the near lights when the aircraft is properly aligned on the glide path.

8.2 Possible Problems Resulting from Differences in Lamp Characteristics

No listing giving intensity setting step number, corresponding regulator current and relative intensity was located in the pertinent FAA documents. Although one can deduce the correspondence from Publication 7110.65A [1] and Handbook 6850.2 [2], inclusion of a definitive listing in the documentation is highly desirable. This listing should also include the lamp types to which a given set of regulator currents is desirable since, as shown in reference [3], the relative intensity-current (or voltage) characteristic varies significantly between lamp types. If the intensity-current (or voltage) characteristic of the lamps used in an approach or runway light system does not correspond to that for which the output of the regulator supplying the circuit was designed, the intensity setting steps recommended in this report and those now listed in Publication 7110.65A are not applicable.

Examples of such mismatches are the use of a regulator designed for use with the 6.6 ampere, 200 watt lamps of the HIRL, TDZL, and RCLS on a centerline or touchdown zone circuit using type L-842 lights having 6.6 ampere, 45 watt lamps or on a MIRL circuit having a 6.6 ampere, 30 watt lamp. Similarly, 7½ KW regulators having 5 intensity setting steps designed for use with 6.6 ampere, 30 and 45 watt lamps are available and the use of such regulators to supply power to HIRL circuits is possible.

An indication of the effects of such mismatches on the relative intensity of a lighting system is given in Table XXXIII.

Table XXXIII. MEASURED RELATIVE INTENSITIES OF SEVERAL LAMP TYPES
AS A FUNCTION OF INTENSITY SETTING STEP

Intensity Setting Step	Design Intensity (Nominal) %	Type A Regulator (for 200W Lamps)				Lamp Current Amperes	Type B Regulator (for 30/45W Lamps)			
		30W Lamp %	45W Lamp %	100W Lamp %	200W Lamp %		30W Lamp %	45W Lamp %	100W Lamp %	200W Lamp %
1	0.016	0.005±	0.02	0.08	0.18	3.4	0.08	0.4	0.8	1
2	0.8	0.08	0.1	0.8	1	3.8	0.5	1.2	2	3
3	4	1.4	2.2	4	5	4.4	3	5	7	9
4	20	16	18	21	24	5.3	20	22	25	27
5	100	100	100	100	100	6.6	100	100	100	100

NOTES: 1) Type A regulator is designed for use with 200W lamps.

2) Type B regulator is designed for use with 30W and 45W lamps.

3) Measured relative intensities of the 30 watt lamp are those of the 6.6A/T10/P; of the 200 watt lamp, those of the 6.6A/T14P, and are very similar to those of the Q6.6AT4 class of halogen cycle lamps; of the 100 watt lamp, those of the Q100T3 class.

4) Measured relative intensities of the 45 watt lamp are those of the 6.6A/T10/P. Relative intensities of the Q6.6A/T2 $\frac{1}{2}$ /CL class approximate those of the 30W lamp listed above.

The following matches to the design relative intensities are evident from the table.

- a. The relative intensities of the 200 watt lamp match the design relative intensities very closely when the lamp is powered through a Type A regulator.
- b. The relative intensities of the 100 watt lamp match the design relative intensities for Steps 2, 3, and 4 closely when the lamp is powered through a Type A regulator.

The following mismatches are evident from the table.

- a. The relative intensity of the 100 watt lamp for Step 1 is significantly lower than the design relative intensity when the lamp is powered through a Type A regulator. When lamps of this type are used in HIRL fixtures, an intensity setting of Step 2 should be used whenever use of Step 1 is specified.
- b. The relative intensity of the 30 watt lamp is significantly lower than the design relative intensity for Step 1, and that of the 45 watt lamp is higher, when the lamp is powered through a Type B regulator.
- c. The Type B regulator should not be used with the 100 and 200 watt lamps and, conversely, the type A regulator should not be used with the 30 and 45 watt lamps because of the bad mismatches with the design relative intensity on Steps 1, 2, and 3.

An even more serious mismatch will occur should older type $7\frac{1}{2}$ KW military regulators providing 5-step control with relative intensities of 1, 3, 10, 30 and 100% when used with 30 watt lamps be used to power 200 watt lamp circuits.

A survey of airports to check for possible mismatches is warranted.

8.3 Methods of Accomplishing Intensity Adjustment

There are numerous ways of accomplishing the intensity adjustment of the several lighting systems once the relation between atmospheric transmissivity, of meteorological visibility and background luminance and the optimum intensity setting for each lighting system is known. Among these are, in decreasing order of sophistication:

- a. Control from the cockpit of the approaching aircraft. Complete flexibility in control appears to be neither necessary nor desirable. The light systems could be set in accordance with the specified intensity settings criteria by the controller before the approach and the settings would then be changed by the pilot as desired. Before the

next approach, the controller would restore the settings to those specified, if necessary, by means of a reset button. The following commands should be provided the pilot.

ALS: - Increase intensity one step; decrease intensity one step.
These commands could be used repeatedly if so desired.

SFL: - ON;OFF

HIRL, TDZL, and RCLS: - Increase intensity one step; decrease intensity one step. These commands could be used repeatedly if desired.

b. Use of a completely automatic ground-based intensity control system. With today's regulators and state-of-the-art computer technology such an automatic system would be much simpler than that developed by NBS. It could easily be made an adjunct to the RVR converter. Capability of pilot over-ride would be highly desirable.

c. Use of an intensity-setting display such as an analog-display meter connected into the transmissometer indicator unit which would display the applicable intensity setting step. This method could be used in combination with a master switch which would set each light system to the applicable step. The positions on the switch should be marked with the visibility condition to which the switch position applies.

When either method b or method c is used, the controller should have individual INCREASE and DECREASE switches available to provide a capability of adjusting the intensity of each of the lighting systems separately at pilot request. These could be momentary contact switches which will produce a one-step change in intensity. A reset switch should also be provided to restore the settings to their design values.

d. Use of the master switch described in "c" without the use of an intensity setting display.

e. The present system, use of a separate intensity control switch for each system with the controller determining the switch settings applicable to the prevailing atmospheric conditions from a table. This is a cumbersome and difficult process, particularly if conditions are variable, since as many as five switches must be set. The procedure can be improved by labeling the switch positions with the applicable atmospheric conditions instead of with arbitrary numbers.

8.4 Relation of Intensity Setting Criteria to RVR Assessments

8.4.1 Night-time Conditions

The Engineering Requirements for this study raised the question, "What is the change in RVR value, assuming fog density remains constant, which results from the new light intensities" and requested a discussion of the significance of the changes.

In the U.S., night-time RVR is based only on the visual range of the lights of the HIRL. Thus, in responding to the question raised by the ER, only differences between the intensity settings of present practice and those recommended in Tables XXI and XXXI are of concern.

For night-time conditions, present practice calls for use of Step 3 for visibilities from 1 to but not including 3 miles; recommended practice calls for use of Step 2 for visibilities greater than 1 mile. Both practices call for use of Step 3 for 1 mile visibility. The RVR and visibility tables of Federal Meteorological Handbook No. 1 [38] show that when the night-time visibility is greater than 1 mile, the RVR is greater than 6000 ft. for Steps 3, 4 and 5. Thus, this change has no effect on RVR values.

Present practice calls for the use of Step 4 for visibilities less than 1 mile; recommended practice calls for use of Step 3 for visibilities in the range of $\frac{1}{2}$ to 1 mile. This change would produce decreases when the visibility is less than 1 mile but not less than $\frac{1}{4}$ mile as shown in Table XXXIV.

These changes would reduce the reported RVR one or two reportable increments depending upon whether the RVR computed on the basis of present intensity settings is in the high or low part of the interval when the present RVR is 2000 feet or lower and two reportable intervals for higher values of (present) RVR.

In considering this question, one must differentiate between values of RVR computed using a fixed value of threshold illuminance (2 mile candles) or a value of threshold illuminance which takes into consideration the effects of changes in intensity setting on the background luminance and hence on the threshold illuminance. As shown in Section 3.2.1 and Table VIII, the threshold illuminance applicable to the HIRL with Step 4 operation is about one and one half times the threshold illuminance for Step 3 operation. If this increase in threshold is taken into account, the decreases in RVR resulting from a change from Step 4 to Step 3 operation will be about two thirds the differences shown in Table XXXIV.

Table XXXIV

DECREASE IN VALUES OF RVR RESULTING FROM
USE OF RECOMMENDED NIGHT-TIME RVR
INTENSITY SETTING CRITERIA

T_{250}	RVR* (feet) Step 4	RVR** (feet) Step 3	Difference (feet)
0.758	6000	4910	1090
0.704	5000	4130	870
0.627	4000	3330	670
0.576	3500	2930	570
0.512	3000	2530	470
0.482	2800	2360	440
0.449	2600	2200	400
0.413	2400	2040	360
0.374	2200	1880	320
0.331	2000	1710	290
0.284	1800	1540	260
0.234	1600	1380	220
0.211***	1510	1300	210

* Computed values based upon a Step 5 intensity of 10,000 candelas, and a fixed illuminance threshold of 2 mile-candles.

** Recommended intensity setting.

*** Lowest transmittance in $\frac{1}{4}$ mile visibility interval.

Observations made at Beddard, England, showed that decreasing the intensity of a runway lighting system, which conformed to Category III criteria, from 100% to 10% increased the visual range of a reference light from 310m to 370m when the RVR was 400m and from 490m to 510m when the RVR was 500m (Letter from A. Horstman to ICAO Working Group on Light Intensity Control dated 10 November 1977). These observations show the effects of scattered light from the runway lighting system in reducing the visual range of a light of fixed intensity. These observations are similar

to some made by the author at the CAA Experimental Station, Indianapolis, on the night of December 25, 1940.

Since a light of fixed intensity was used as a reference source in the U.K. tests, these observations indicate the effects of dimming the runway lights on such lights as aircraft position lights, taxiway entrance lights, and obstruction lights near the end of the runway. These observations are not indicative of the effects of dimming on the visual range of lights of the system that is being dimmed for then the lights of the system which are at the limit of visibility are not of constant intensity but decrease in intensity with the nearer lights which are illuminating the intervening fog. The author has never observed an increase in visual range of the lights of a system with decrease in intensity of the system. However, often the background luminance applicable to a given lighting system is produced not only by that system but by other systems as well. Thus, if, with an RVR of 2000 feet, an aircraft is over the approach lights, dimming these lights (or turning them off) will increase the visual range of the runway lights. Similarly, dimming, or turning off, the touchdown zone and centerline lights will increase the visual range of the edge lights, and conversely.

The conclusion to be drawn from observations of this type is that in choosing the night-time intensity setting of any one of the approach or runway lighting systems, consideration should be given to the effects of this intensity setting on the visual range of the lights of related systems.

8.4.2 Daytime Conditions

Present intensity setting criteria for HIRL in daylight call for use of Step 5 when the visibility is less than a mile and use of Step 4 for visibilities 1 - 2 miles inclusive. The criteria recommended in this study (Table XXXI) call for use of Step 5 operation when the visibility is less than 3 miles and the use of Step 4 under special conditions for visibilities of 3 miles and more. The transmittance over a 250 ft baseline, t_{250} at the lower limit of the one-mile visibility increment is 0.865. Since for all t_{250} 's greater than 0.843, RVR is computed from the visual range of a black object viewed against a sky or fog background, this difference in intensity setting will have no effect on the RVR.

8.4.3 Twilight Conditions

FAA Publication 7110.65A contains no specific intensity setting criteria for twilight conditions. Hence, the changes in RVR which would be introduced by use of the recommended intensity setting criteria are unknown.

8.5 Considerations for a Test Program

As is evident from the preceding material, there is little to be gained from a test program using observations other than those made from an aircraft cockpit, or simulated cockpit, located at the proper points in space. Hence, most testing should be flight testing. Care should be taken to insure that such testing does not degenerate into a simple comparison of visual ranges, but includes an evaluation of annoying glare as well as of visual range in judging the suitability of an intensity setting. In view of the very large individual differences in discomfort glare reported by Bennett [27], an extensive test series by a limited number of pilots would be of little value. Therefore, only a limited number of flight tests should be conducted at NAFEC. Such tests should be followed by an operational evaluation of the intensity setting criteria by requesting a number of airports to use the recommended intensity setting criteria and make a systematic effort to obtain pilot evaluation of these criteria. Such evaluations would then be considered in establishing specified intensity setting criteria. During these tests emphasis should be put on obtaining data which will answer the following questions.

A. For High Intensity Lighting Systems

1. Is operation of the ALS at night on Step 2 when the visibility is 3 to 5 miles more suitable than operation on Step 1?
2. What are the effects of operating the runway lights on Step 3 instead of Step 4 during visibility conditions in the $\frac{1}{4}$ to 1 mile range?
3. Is operation of the approach and runway lighting systems during low-sun and pre- and post twilight conditions as recommended in Table XXXI advantageous?
4. Are the intensity setting criteria for twilight conditions, Section 6.2, suitable?

B. For Medium Intensity Lighting Systems

The intensity setting criteria recommended for the medium intensity lighting systems using type L802 lights are those which will yield intensities that are consistent with those recommended for the high intensity systems to the extent permitted by the limitations imposed by the regulators specified for use with the medium intensity systems. No specific tests are recommended for these medium intensity systems. Instead, the intensity setting criteria recommended for such systems should be re-examined after the tests of the criteria for the high intensity systems are completed, and then should be adjusted if necessary.

9. CONCLUSIONS

Recommendations for intensity setting criteria night-time, twilight, and daytime have been prepared using theoretical studies, field tests, and operational experience as a guide. (See Tables XXI, XXXI, and Section 6.2) Factors to be considered in a test program have been prepared. (Section 8.5)

10. RECOMMENDATIONS

It is recommended that:

1. Studies be made of the suitability of the intensity setting criteria of Tables XXI, XXVII, and XXXI recommended in this report for adoption as U.S. practice.
2. That only 5-step regulators be used with the "simplified" approach light systems. (Section 5.9)
3. The suitability of a fixed night-time threshold illuminance of 2 mile candles be re-examined. (Section 8.4)
4. Consideration be given to replacing the present switching arrangements for intensity control with a system which couples intensity control to the transmissometer. (Section 8.3)
5. Steps be taken to improve the method of accomplishing intensity adjustments by the air traffic controller or flight service specialist using the methods discussed in this report as a guide. (Section 8.3)
6. A check be made of the constant current regulators used in runway lighting systems to insure that the output current steps of the regulator are suitable for the lights which it supplies. (Section 8.2)

REFERENCES

1. "Air Traffic Control", FAA Publication 7110.65A, Chg 4, January 1, 1979.
2. "Visual Guidance Lighting Systems", FAA Handbook 6850.2, Chg 8 (Aug 27, 1975).
3. "Current-Intensity, Voltage-Intensity, and Current-Voltage Characteristics of Airfield Lighting Lamps", NBS Report 6190 Supplementary, September 1964.
4. International Civil Aviation Organization, Visual Aids Panel: a. Sixth Meeting, Montreal, 6-17 March 1972, Document 9005, VAP/VI (1972); and b. Seventh Meeting, Montreal, 2-20 February 1976, Document 9162 VAP/7 (1976).
5. Douglas, C. A. and Booker, R. L., "Visual Range: Concepts, Instrumental Determination, and Aviation Applications", NBS Monograph 159 (June 1977).
6. Douglas, C. A., "Problems in the Control of Glare in Approach- and Runway-Lighting Systems", NBS Report 5747 (January 1958).
7. Simeroth, J. W., "Horizon - Sky Brightness Produced by Airfield Lighting", NBS Report 8019 (June 1963).
8. Padmos, P. and Boorgaard, J., "The Veiling Luminance Caused by Atmospheric Scatter of Approach and Runway Lighting - Some Measurements at Schiphol Airport", Institute of Perception TNO (Soesterberg, Netherlands), Report No. IZF 1976-C17 (1976).
9. Lefkowitz, M. and Schlatter, E. E., "An Analysis of Runway Visual Range", FAA Report No. RD-66-100 (December 1966).
10. Kevern, G. M., "Resonant-Circuit Constant-Current Regulators", AIEE Transactions, Electrical Engineering, 64, 807 (1942).
11. "Regulator, Constant Current, Runway Lighting, 240V Primary 4KW, Type C-1", Military Specification MIL-R-6365A (12 January 1951).
- 12a. "Visual Air Navigation Facilities", Air Force Technical Manual 88-14, July 1, 1954.
- 12b. Air Force Technical Order 35F8-14-1, quoted in reference 6.
- 12c. "Air Traffic Control", Air Force Manual AFM 60-5 (1 February 1968).

13. "Airport Lighting", FAA Publication 7110.8 Chg 4, Section 8 (July 1, 1968).
14. "Regulator, Current, Runway Lighting, 120 Volt, 2½ KW, AC, Type C-2", Military Specification MIL-R-7643A(ASG) (28 April 1953).
15. Not used.
16. "The Lights That Bring Them In", Manufacturer's Brochure, Line Material Co., East Stroudsburg, PA, circa 1945.
17. Breckenridge, F. C. and Douglas, C. A., "Development of Approach- and Contact-Light Systems", Ill. Eng. 40, 785 (1945).
18. Kevern, G. M., "Approach and Runway Lighting for Adverse Weather Conditions", Ill. Eng. 41, 455 (1946).
19. Landing Aids Experiment Station, Airfield Lighting Division, "Progress Report for 1947" (1948).
20. "Report on the Development of a Photoelectric Control for Approach and Runway Lights", NBS Report N43-4/47 (1947).
21. Landing Aids Experiment Station, "Final Reports", 1949 (1950).
22. "Installation and Test of Automatic Light Intensity Control System for Approach and Runway Lights, Report No. 2, Final Report", NATC Report Project TED No. PTR AE 2201 (9 April 1954).
23. Gilbert, M. S. and Pearson, H. J. C., "A Study of the Visibility and Glare Ranges of Slope-Line Approach Lights", CAA Technical Development Report No. 150 (November 1950).
24. "U. S. Position for Sixth Meeting of the Visual Aids Panel, Agenda Item 3, 'Light Intensity Control'", FAA Document IGIA 74/3.31A (March 6, 1972). (Also Working Paper VAP-WP/9, Jan 1, 1972 of the Sixth Meeting of the VAP.)
25. "Light Intensity Control, Advance Documentation for the Sixth Meeting of the Visual Aids Panel", FAA Document IGIA 74/3.32A (March 10, 1972).
26. Padmos, P. and Vos, J. J., "Intensity Control of Approach and Runway Lighting at Low Visibility at Night - A Theoretical Study", Institute of Perception, TNO (Soesterberg, Netherlands) Report No. IZF-1974-C2 (1974).

27. Bennett, C. A., "Discomfort Glare: Concentrated Sources - Photometric Study of Angularly Small Sources", Jour. Ill. Eng. Soc. 7, 2 (1977).
28. Balder, J. J., "Light Intensity Tolerances in a Row of Runway Lights", N. V. Philips Gloelampenfabrieken Lighting Laboratory, Reference 7/170/3.
29. Inagaki, J., "Visual Information Transmission to Navigators for Navigation Safety", Jour. Light and Visual Environment (of the Japanese Illuminating Engineering Society) 1, 70 (1977). (In English)
30. Weinstein, B., "Intensity Control of Flashers", FAA Report No. FAA-RD-72-54 (June 1972).
31. "Sequenced Flashing Lighting System, Elevated, and Semiflush with Dimming and Monitoring", FAA Specification FAA-E-2628a (July 6, 1977). (The punctuation of the title is that of the specification.)
32. Appendix A to VAP letter SP 5/2-113 (6 January 1969).
33. Duntley, S. Q., "The Reduction of Apparent Contrast by the Atmosphere", Jour. Opt. Soc. of Amer. 38, 179 (1948).
34. Douglas, C. A., "Some Factors Affecting the Relation between Reported Visibility and Visibility from Aircraft", NBS Report 2715 (Aug 12, 1953).
35. "Specification for L-828 Constant Current Regulators", FAA Advisory Circular AC 150/5345-10c (October 22, 1971).
36. "Specification for L-812 Indoor Type Constant Current Regulator Assembly; 4KW and 7 1/2KW; with Brightness Control for Remote Operation", FAA Advisory Circular AC 150/5345-11 (February 2, 1964).
37. "Medium Intensity Approach Lighting System with Runway Alignment Indicators (MALSR), Specification FAA-E-2325A, B or C, and "Medium Intensity Approach Lighting System (MALS)", Specification FAA-E-2700 dated October 13, 1978.
38. "Surface Observations", Federal Meteorological Handbook No. 1, 2nd Ed., January 1, 1979.

ACKNOWLEDGEMENTS

The author gratefully acknowledges the assistance of Mr. J. W. Simeroth (ARD-432) in supplying pertinent FAA and ICAO documentation, and of Mr. Leon Reamer of NAFEC, and his co-workers, who made the onerous and difficult measurements of night-time background luminance during periods of low visibility.

APPENDIX I

PRESENT FAA INTENSITY SETTING CRITERIA

(From FAA Publication 7110.65A [1])

ALS Intensity Setting

Step	Visibility—(Applicable to runway served by lights)	
	Day	Night
	5	Less than 1 mile*
4	1 to 3 miles	When requested.
3	3 to 5 miles	Less than 1 mile.*
2	When requested	1 to 3 miles.
1	Greater than 5 miles.	Greater than 3 miles.

*and/or 6000 feet or less of RVR on the runway served by the ALS and RVR.

HIRL, RCLS, TDZL Intensity Setting

Step	Visibility	
	Day	Night
	5	Less than 1 mile*
4	1 to 2 miles inclusive*	Less than 1 mile*
3	When requested	1 to but not including 3 miles.*
2	When requested	3 to 5 miles inclusive
1	When requested	More than 5 miles.

*and/or appropriate RVR/RVV equivalent.

Three Step MALS/Three Step RAIL

Step	Visibility—(Applicable to runway served by lights)	
	Day	Night
	3	Less than 2 miles
2	2 to but not including 3 miles	1 to but not including 3 miles*
1	When requested	3 miles or more

* At locations providing part-time control tower service, if duplicate controls are not provided in the associated FSS, the MALS/RAIL shall be set on intensity step #2 during the hours of darkness when the tower is unmanned.

Two Step MALS/One Step RAIL

Step	Visibility—(Applicable to runway served by lights)	
	Day	Night
	MALS HI/RAIL ON	Less than 3 miles
MALS LOW	When requested	3 miles or more

* At locations providing part-time control tower service, if duplicate controls are not provided in the associated FSS, the MALS shall be set to low intensity during the hours of darkness when the tower is unmanned.

HIRL associated with MALS/RAIL

Step	Visibility	
	Day	Night
	5	Less than one mile
4	1 to 2 miles	Less than one mile
3	When requested	1 to 3 miles inclusive
2	When requested	Over 3 to 5 miles inclusive
1	When requested	More than 5 miles

MIRL associated with MALS/RAIL

Step	Visibility	
	Day	Night
	3	Less than 2 miles
2	2 to 3 miles	1 to 3 miles
1	When requested	More than 3 miles

Note 1: All criteria provide for adjustments in the stated settings to meet local conditions, pilot requests, and controller's judgment.

Note 2: The intensity setting criteria for the ALS and HIRL have been unchanged since 1968 (or earlier), and are as given in FAA Publication 7110.8 Chg 4. The criteria for the TDZL and RCLS were established in 1969 by FAA Publication 7110.10.

APPENDIX II
FACTORS DETERMINING THE VISUAL RANGE
OF
LIGHTS AND OBJECTS

NOTE: A detailed treatment of the factors discussed below is contained in Reference [a].

II-1 Allard's Law

The illuminance at an observer's eye, produced by a light, determines if the light will be seen. The illuminance E produced at a distance x by a source of luminous intensity I in an atmosphere having a transmissivity (transmittance per unit distance) T is:

$$E = IT^x/x^2 \quad (1)$$

If the illuminance E , at the eye, is greater than E_m , the minimum perceptible (or threshold) illuminance, the light will be visible. The distance at which E is equal to E_m is designated as V , the visual range of the light. Then [b]:

$$E_m = IT^V/V^2 \quad (2)$$

Equation (2) is generally known as Allard's Law. [c]

Equations (1) and (2) are strictly applicable only when the luminance of the background is small compared to the average luminance of the light. [d] Otherwise Equation II-1 becomes:

$$E = [I - (L - L')A] T^x/x^2 \quad (3)$$

where L is the luminance of the background of the light, L' is the average luminance of the unlighted projector, both in candelas per unit area, and A is the area of the entire projector projected on a plane normal to the line of sight.

Both L and L' are measured in the direction of the line of sight from a position near the light.

The quantity $(L - L') A$ is the intensity required of the light to make its average luminance equal to that of the background. The visual range of the light is determined by the net intensity, that is, the difference between the measured intensity of the light and this intensity. Typically, the term $(L - L') A$ has a significant effect on the visual range of a signal light only under daylight conditions when the light is dimmed or when the light has a low average luminance in the direction of view.

11-2 Koschmeider's Law

The distance V_0 at which a large black object can be seen against the horizon sky is given by the relation:

$$\epsilon = T^{V_0} \tag{4}$$

where ϵ is the minimum perceptible contrast, or threshold contrast, of the observer.^[e] A value of 0.05 is considered representative of the daylight contrast threshold of a meteorological observer.^[f]

Equation (4) is a particular case of Koschmeider's law.^[c, g] If the object is not black, equation (4) becomes

$$\epsilon = [(L_0 - L_H)/L_H] T^V \tag{5a}$$

or

$$\epsilon = C_0 T^V \tag{5b}$$

where L_0 is the luminance of the object, L_H is the luminance of the horizon sky, V is the visual range of the object, and C_0 is the inherent contrast between the object and the sky. (Note that ϵ may be either positive or negative, having the same sign of $L_0 - L_H$.) Equation (5) applies to artificially lighted as well as naturally lighted objects.

Equation (4) and (5) may be used without significant error in computing the visual range of objects, or area sources, viewed against a terrestrial background if the distance, d , between the object and its background exceeds one half of V_0 of equation (4).

Equations (1) through (5) are based upon the assumption that the transmittance of the atmosphere is independent of wavelength throughout the visible portion of the spectrum. In clean fogs and in rain this assumption is usually valid. However, in smoke or dust there may be occasion, be significant differences with the transmittance of red light being greater than the transmittance of blue light, and these equations must be applied wavelength by wavelength.

III-3 Relation between Visual Range of Lights and Daytime (Meteorological) Visibility

The intensity required for a light to be seen a distance equal to the daytime (meteorological) visibility can be computed from equation (1) by computing the applicable value of the transmissivity, T , from equation (4).

Combining equations (1) and (4) and solving for I yields

$$I = E_m V^2 / \epsilon \quad (6)$$

Using as the value of E_m the illuminance threshold used for daytime RVR computations in the U.S., 1000 mile candles and as the value of ϵ the contrast threshold agreed upon by the World Meteorological Organization, 0.05, in equation (6) yields

$$I = 20000 V_m^2, \quad (7)$$

where V_m is the daytime meteorological visibility.

If the visual range of the light is not equal to the meteorological visibility, combining equations (2) and (4) yields

$$I = 1000 V^2 / 0.05 (V/V_m) \quad (8)$$

where V is the visual range of the light and V_m is the meteorological visibility.

II-4 Representative Intensity

The concept of using a representative intensity in computing the effective visual range of airfield lights originated in the U.S. during the early development of the runway visual range program.

Its application is explained in the following quotation:

"The selection of an intensity representative of an approach or runway light is at best a somewhat arbitrary procedure. In the past the maximum intensity of the light has been used frequently. This is unsatisfactory since the probability that a pilot will be precisely in the peak of the beam is very low. - - - -

To avoid undue influence on the representative intensity which would be produced by a narrow peak having an intensity much greater than other parts of the beam in the determination of representative intensity, all intensities more than three times the minimum intensity within the region are treated as being three times the minimum."

This concept was adopted in 1966 at the Fifth Meeting of the Visual Aids Panel and has been used in pertinent ICAO documents since that time.

II-5 Effective Intensity

The intensities used in characterizing flashing lights are effective intensities computed by methods agreed upon by ICAO and used in the U.S. for evaluating signal lights [h page 264, i].

For short flashes, such as those emitted by the approach-light flashers, this effective intensity is given by

$$I_e = 5 \int_0^t I dt$$

where

I_e is the effective intensity,
 I is the instantaneous intensity at any time during the flash, and
 t is the time since the start of the flash.

The instantaneous intensity is integrated over the entire flash.

REFERENCES FOR APPENDIX II

- a. Douglas, C. A. and Booker, R. L., "Visual Range: Concepts, Instrumental Determination, and Aviation Applications", FAA Report No. FAA-RD-77-8 (March 1977); also National Bureau of Standards Monograph 159 (June 1977).
- b. Reynaud, L., *Memoir Upon the Illumination and Beaconage of the Coasts of France (1864)*, Translated, for the Use of the Light-House Board of the United States by Major Peter C. Hains, USA, Washington: Government Printing Office, 1876.
- c. Middleton, W. E. K., "Vision Through the Atmosphere", University of Toronto Press (1952).
- d. Kevern, G. M., Effect of Source Size Upon Approach Light Performance, *Ill. Eng.* 45, 96, 1950.
- e. Koschmieder, H., *Theorie der horizontalen Sichtweite*, *Beitr. Phys. Atmos.* 12, 33-55, 171, 1925.
- f. Douglas, C. A. and Young, L. L., Development of a Transmissometer for Determining Visual Range, CAA Tech. Dev. Rep. No. 47, Feb. 1945.
- g. Duntley, S. Q., et al., Visibility, *Appl. Opt.* 3, 549, 1964.
- h. "The Perception and Application of Flashing Lights, an International Symposium held at Imperial College, London, 19-22 April 1971", Adam Hilger Ltd., London (1971).
- i. "IES Guide for Calculating the Effective Intensity of Flashing Lights", *Ill. Eng.* 59, 747 (1964).

APPENDIX III

BRILLIANCY RATING SCALE FOR APPROACH AND RUNWAY LIGHTS

In 1940 and 1941 the National Bureau of Standards conducted field studies of approach lighting on Nantucket Island. [a] As part of that work a qualitative system for rating the brilliancy of approach and runway lights was developed. These data were taken by a stationary observer using a relatively short system of lights. Experience indicates that taking into account the losses in the windscreen, the cockpit lights, and the effects of a moving pilot, the illuminances corresponding to each step found at Nantucket should be increased by a factor of about four [b]. The revised relation is shown in Figure III-1. The following descriptions apply to the brilliancy ratings.

- Threshold (T) - Light could just be seen.
- Visible (V) - Light was intense enough to be seen but was of doubtful use.
- Faint (F) - Light could be seen distinctly but was of too low brilliancy to be considered a desirable signal.
- Weak (W) - Light was not as brilliant as is desired but was considered a usable signal.
- Satisfactory (S) - Light was at the brilliancy considered the most satisfactory for use.
- Bright (B) - Light was more brilliant than is desired but was thought to be a usable signal.
- Glaring (G) - Light was considered an unsatisfactory signal as it was definitely annoying.

Note that there is a factor of approximately 4 between the brilliancy steps and that there is a ratio of about 1000 between the brilliancy ratings of "visible" and "glaring." This latter ratio has received broad acceptance as being applicable to approach and runway lighting design. [b,c,d]

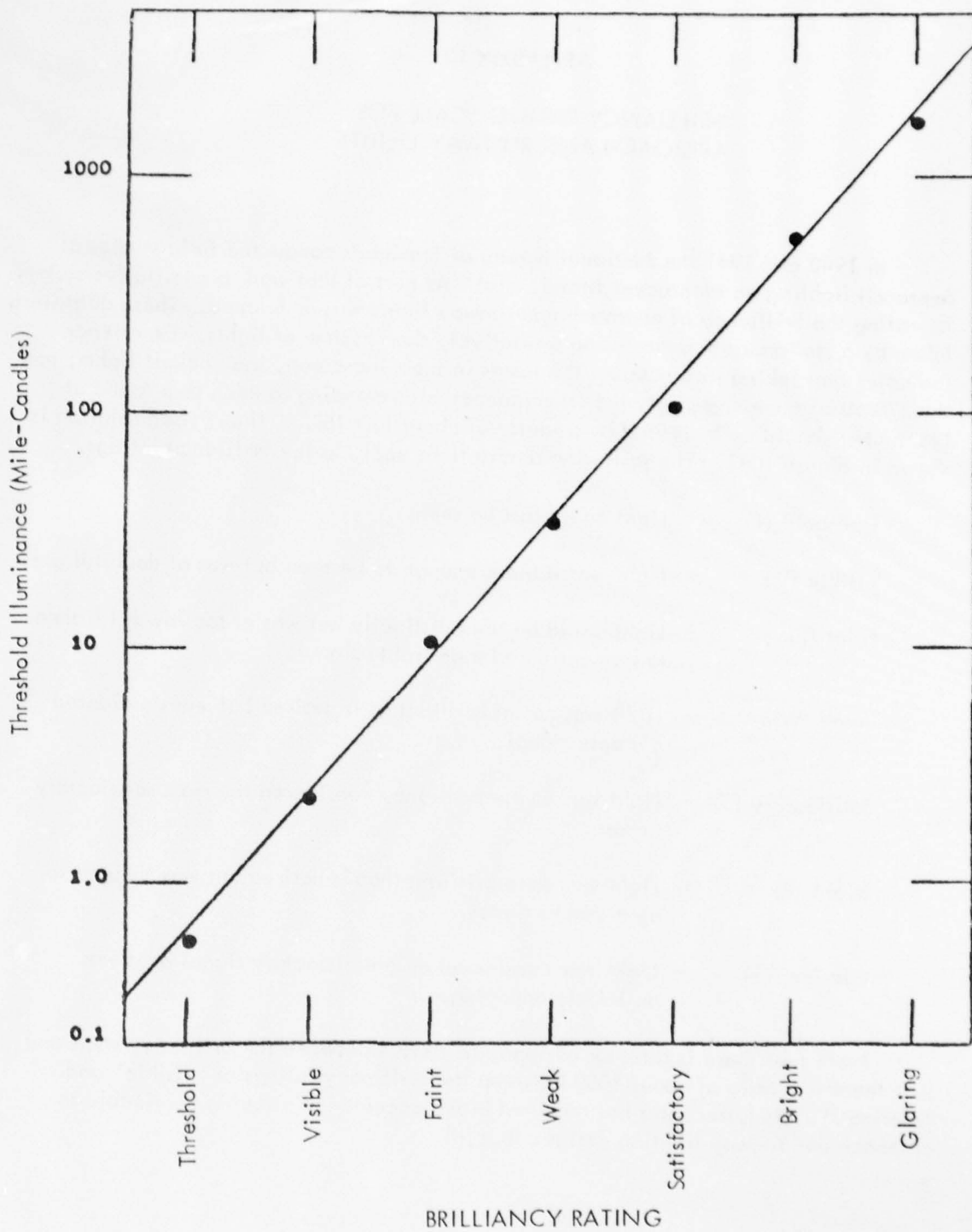

Figure III-1. Brilliancy ratings of approach and runway lights under night-time conditions.

REFERENCES FOR APPENDIX III

- a. Breckenridge, F. C. and Douglas, C.A., "Development of Approach- and Contact-Light Systems", *Ill. Eng* 40, 785 (1945).
- b. Douglas, C.A., "Problems in the Control of Glare in Approach and Runway Lighting Systems," NBS Report 5747, January 1958.
- c. Rutgers, G.A. W., "Zichtbaarheid van Signallichten", *Electro-Technick*, 20 January 1948, nr. 3 (in Dutch).
- d. Gilbert, M.S. and Pearson, H.J.C., "A Study of the Visibility and Glare Ranges of Slope-Line Approach Lights," CAA Technical Development Report 150, November 1951.

APPENDIX IV

LIST OF AIRPORTS WHERE USED IN LIGHT
INTENSITY SETTINGS UNDER DIFFERENT METEOROLOGICAL CONDITIONS
BY U. S. ADVISORY COMMITTEE ON VISUAL AIDS
FOR APPROACH AND LANDING (1972)

<u>Airport</u>	<u>Runway</u>
Burlington, Vermont	15
Portland, Maine	11
Teterboro, New Jersey	6
Buffalo, New York	23
Charleston, West Virginia	23
Atlanta, Georgia	9R
Louisville, Kentucky	1
Nashville, Tennessee	2L
New Orleans, Louisiana	10
Oklahoma City, Oklahoma	35R
Dallas, Texas (Love)	13R
Sacramento, California	16
Oakland, California	29
Reno, Nevada	16
Seattle, Washington (Seattle-Tacoma)	16R
Portland, Oregon	10L
Boise, Idaho	10L
Salt Lake City, Utah	34L
Denver, Colorado	35
Billings, Montana	9
Kansas City, Missouri (Municipal)	18
St. Louis, Missouri (International)	12R
Des Moines, Iowa	30
Cleveland, Ohio	5R
Minneapolis, Minnesota (Minneapolis-St. Paul)	4
Indianapolis, Indiana	4L

APPENDIX V

VISUAL RANGE OF THE RUNWAY AND ITS SURFACE MARKINGS

Although in the computations of RVR, in daytime, the visual range of the runway or runway surface markings is sometimes assumed to be equal to the meteorological visibility both in the U.S. [a] and internationally [b], this assumption is incorrect as will be made evident by the following discussion.

Meteorological visibility is based upon the visual range of a "large" black, or nearly black, object viewed against a sky or fog background. It is dependent only upon the transmittance of the atmosphere and a fixed contrast threshold. It is independent of the sun position, the luminance of the object, and the luminance of the background. Visibility is computed from Koschmieder's Law,

$$\epsilon = T^{V_m} \quad (1)$$

where

ϵ is the contrast threshold (a value of 0.05 is used internationally, a value of 0.055 in the U.S.)

T is the atmospheric transmissivity, and

V_m is the meteorological visibility.

The runway and the runway surface markings are viewed against an immediate terrestrial background, not the sky. Their visual range is dependent upon their luminance, the luminance of their background, the luminance of the portion of the sky making the same angle with the sun as does the line of sight. (In the case of a landing aircraft, this portion of the sky is within a few degrees of the horizontal projection of the line of sight.) The relation for determining visual range was developed by Duntley [c] and is much more complex than Koschmieder's Law; namely,

$$\epsilon = C_o [1 + (L_s/L_b) (T^V - 1)]^{-1} \quad (2)$$

where

ϵ and T are as previously defined,

C_o is the inherent contrast between the runway, or runway surface markings, and the immediate terrestrial background,

L_s is the luminance of that portion of the sky making the same angle with the line of sight as does the sun,

L_b is the inherent luminance of the background, and

V is the visual range of the runway, or of the runway surface markings.

In 1953, Douglas studied the operational significance of visual ranges computed from equation (2). [d] He found that under overcast conditions the visual range of runway surface markings ranged typically from about 0.3 to 0.6 of the meteorological visibility. (The visual range of the runway would usually be less than the visual range of its markings.)

Under low sun and hazy or thin cloud conditions, the factor could fall to 0.1 or lower if the line of sight was up-sun.*

Thus, even though the visual range of a lighting system does not equal the meteorological visibility under many seeing conditions, its visual range will often be greater than that of the runway or of its surface markings.

REFERENCES FOR APPENDIX V

- a. "Surface Observations", Federal Meteorological Handbook No. 1, 2nd Ed. (January 1, 1979), page A 6-3.
- b. "International Standards and Recommended Practices - Aerodromes - Annex 14 to the Convention on International Aviation", 7th Edition (June 1976), page 12.
- c. Duntley, S.Q., "The Reduction of Apparent Contrast by the Atmosphere", Jour. Opt. Soc. Amer. 38 179 (1948).
- d. Douglas, C.A., "Some Factors Affecting the Relation between Reported Visibility and Visibility from Aircraft", NBS Report 2715 (Aug. 12, 1953).

* The author once observed an extreme example of the effect. With the elevation of the sun about 20° , a cloud cover which just obscured the sun and a meteorological visibility of about 1/4 mile, the visual range in the up-sun direction of freshly painted runway markings on a moist black-top runway was about 30 feet and the markings were darker than the runway! In the down-sun direction the visual range of the markings was about 1/4 mile.