

AD-A075 959 ADMIRALTY SURFACE WEAPONS ESTABLISHMENT PORTSMOUTH (E--ETC F/G 17/9
A LINEAR ARRAY ANTENNA OF GREATLY REDUCED SIZE AND WEIGHT.(U)
FEB 74 A C LARGE

UNCLASSIFIED

ASWE-TR-74-2

DRIC-BR-39420

NL

(OF)

AD
A075959



END
DATE
FILMED
11-79
DDC

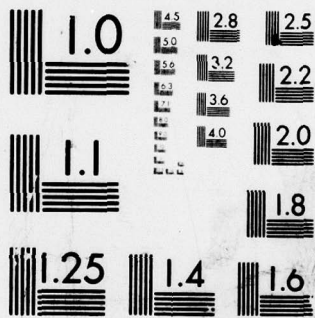

MICROCOPY RESOLUTION TEST CHART
NATIONAL BUREAU OF STANDARDS-1963-A

TR-74-2

UNLIMITED

651

LEVEL

9 TECHNICAL REPORT TR-74-2
TOPIC R-6 BR 39420

ADA 075959

6 A LINEAR ARRAY ANTENNA OF GREATLY REDUCED SIZE AND WEIGHT.

by

10 A. C. Large

11 Feb 74

18 DRIC

19 BR-39420

12 15

14 ASWE-TR-74-2

DDC
RECEIVED
NOV 2 1974
A

Crown Copyright 1974

DDC FILE COPY

ADMIRALTY SURFACE WEAPONS ESTABLISHMENT
PORTSMOUTH HANTS

UNLIMITED

004 500

elt

DISCLAIMER NOTICE

**THIS DOCUMENT IS BEST QUALITY
PRACTICABLE. THE COPY FURNISHED
TO DDC CONTAINED A SIGNIFICANT
NUMBER OF PAGES WHICH DO NOT
REPRODUCE LEGIBLY.**

DDC FILE COPY

UNLIMITED

TECHNICAL REPORT TR-74-2
February 1974

A LINEAR ARRAY ANTENNA OF GREATLY REDUCED SIZE AND WEIGHT

by A C Large

Approved by G A Halnan
Head of XWG Division

ABSTRACT

A new type of antenna design is described that could be applied to radar antennas for surveillance or navigational purposes. Compared with antennas in current use large reductions, typically 50-70% in cross sectional size and overall weight, should be obtainable with this antenna design.

ADMIRALTY SURFACE WEAPONS ESTABLISHMENT
PORTSMOUTH HANTS

Accession For	
NTIS GRA&I	<input checked="" type="checkbox"/>
DDC TAB	<input type="checkbox"/>
Unannounced	<input type="checkbox"/>
Justification	
By _____	
Distribution/	
Availability Codes	
Dist.	Availand/or special
A	23 A

(i)

LIST OF CONTENTS

	<u>Page No</u>
TITLE PAGE AND ABSTRACT	(i)
LIST OF CONTENTS AND ILLUSTRATIONS	(ii)
1. INTRODUCTION	1
2. CURRENT ANTENNA DESIGNS	1-2
3. THE "MULTIPLE REFLECTION" OR "BACKFIRE" ANTENNA	2-3
4. APPLICATIONS OF THE MULTIPLE REFLECTION PRINCIPLE TO LINEAR APERTURES	3
5. THE EXPERIMENTAL ANTENNA	3-4
6. COMPARISON OF ANTENNAS	4
7. SUGGESTED ANTENNA CONSTRUCTION	4-5
8. CONCLUSIONS	5
9. REFERENCES	5

LIST OF FIGURES

Figures 1a - 1d	Alternative Methods of Forming the Elevation Beam of a Linear Array Antenna
Figures 2a - 2d	Antennas with Multiple Reflection or "Backfire" Apertures
Figures 3a - 3c	Multiple Reflection Apertures Applied to Linear Antennas
Figures 4a - 4c	Azimuthal Radiation Patterns
Figures 5a - 5b	Comparison of Linear Arrays with Flared and Multiple Reflection Apertures
Figures 6a - 6b	Estimated Reductions of Back to Back Mounted MRA Antennas over a Single Flared Antenna

1. INTRODUCTION

A shipborne radar antenna for surveillance or navigational purposes usually has to be mounted in a high position on the ships structure or mast in order to obtain unobstructed radar coverage.

Reduction in the weight and size of the antenna can be advantageous, particularly if the antenna is required to be stabilised against ship motions.

Some of these factors and possible advantages are:-

- (a) Reduced "top weight" of the ship (particularly important for small ships).
- (b) Less windage.
- (c) Less power required to rotate the antenna.
- (d) Increase in rotation rate (giving increased data gathering rate).
- (e) Increase in azimuthal aperture of antenna (with same stabilising pedestal and drive power).
- (f) Increased data rate by "back to back" mounting of two antennas (with same pedestal unit).

2. CURRENT ANTENNA DESIGNS

A typical antenna for radar surveillance or navigation is required to have a beam that is narrow in the azimuthal plane ($1^\circ - 4^\circ$) and wide in the elevation plane ($20^\circ - 40^\circ$).

The narrow beam width in azimuth is often obtained from a linear array of slot elements cut along one wall of a waveguide. The power amplitude distribution along the slotted array is arranged so that together with a linear phase distribution the design requirements of beam width and side lobe levels are met. A typical antenna designed for surveillance purposes in L band and utilising a flared aperture is shown in Figure 1a.

The wider elevation beam width is often formed by a flared section, Figure 1b. Basic advantages and disadvantages of this method of beam width control together with two alternatives utilising stacked arrays are shown in Figures 1b, 1c and 1d respectively. In order to obtain well focussed elevation patterns with a flared aperture, the phase error across the aperture must be small. Minimum flare lengths (l) for acceptable patterns should be about three times the height of the aperture (H), resulting in a fairly bulky antenna cross section. Advantages of an antenna with a flared aperture are, that only one slotted waveguide linear array is required, and that the elevation beam width can be varied simply by variation of H and l.

The azimuthal radiation patterns of linear arrays, using slot elements displaced from or inclined about the centre line of the waveguide wall in which they are cut, suffer from high "grating" side lobes. These are usually of a higher amplitude than the normal side lobes of the antenna. The level of the grating lobes can be reduced to below that of the normal side lobes by means of a "filter", consisting of a narrow parallel plate section mounted centrally on the slotted face of the waveguide (Figures 1b and 1c). The filter adds to the depth of the array.

An advantage of an antenna design using stacked arrays is that a large reduction in depth (L) is possible (Figure 1c). The depth can be even further reduced by constructing the individual arrays from slots positioned along the centre line of the waveguide, and causing them to radiate by mounting irises inside the waveguide closely adjacent to them (Figure 1d), (Reference 1). Very low grating lobe levels are produced by arrays of this type making the grating lobe filter unnecessary.

Disadvantages of stacked array designs are that firstly, more than one precision slotted waveguide is needed to give the range of elevation beam widths stated at the beginning of this section, making the resulting antenna more expensive than the equivalent flared design. Secondly, that the elevation beam width can only be varied by stepped increments, which are directly dependent upon the number of arrays used to form the vertical aperture.

3. THE "MULTIPLE REFLECTION" OR "BACKFIRE" ANTENNA

The linear array design to be described later in this report overcomes most of the limitations of both the flared and stacked antenna designs. Only one slotted waveguide array is needed, and the elevation beam width can be varied over a range similar to that stated in Paragraph 2.

The antenna depth of $0.6 \lambda_0$, is much less than the flared design and is about midway between the stacked antennas shown in Figures 1c and 1d. The features are obtained by the use of a "Multiple reflection" or "backfire" aperture to form the elevation beam of the antenna.

Antennas using backfire or Multiple reflection principles were originally described by Ehrenspeck in 1960 (Reference 2). A very compact antenna called the "short backfire" utilising the same principle was described by the same author in 1965 (Reference 3). This antenna is shown in Figure 2a. The principle of operation will not be fully described here, but basically the antenna consists of a cylindrical cavity a half wavelength deep formed from two circular metal plates of dissimilar diameters. Microwave energy is introduced into the cavity by a dipole placed midway between the plates, and a "multiple reflection" condition is set up within the cavity. Energy is leaked from the cavity at each reflection via the "wall" formed by the small plate. The radiation pattern resulting from this is similar to that of a multiple element endfire array of much greater physical depth.

Use of a dipole feed in the above antenna has tended to restrict its use to frequencies of S band (3 GHz) and lower, also the antenna bandwidth is limited to about 3% mainly due to the dipole impedance properties.

Recent application of a waveguide feed to the short backfire antenna, (Reference 4), has shown that for frequencies above S band several important advantages over the dipole fed version can be obtained, these include:-

- (a) Simple design, (dipole tolerances and coaxial line feed are eliminated).
- (b) Higher power operation.
- (c) Improved impedance bandwidth (and overall antenna bandwidth $\approx 10\%$).
- (d) Weather protection radome or pressure seal easily built into the design.

An important advantage in common with the dipole fed antenna is that a large reduction in depth ($l = 0.6 \lambda_0$) and hence weight is obtained with this design when compared with waveguide fed horns and polyrods that produce equivalent radiation characteristics.

Figures 2b, 2c and 2d show the waveguide fed antenna and its radiation properties with the feed waveguide in two positions within the cavity (see Reference 4). It can be seen that the 3 dB beam widths in both the E and H planes lie within the range of elevation beam widths required for a general surveillance radar.

4. APPLICATIONS OF THE MULTIPLE REFLECTION PRINCIPLE TO LINEAR APERTURES

It has been demonstrated experimentally that the circular cavity of Figure 2b can be replaced by a trough shaped aperture and that this can be fed by a waveguide Figure 3a, or a linear aperture antenna such as a sectoral horn Figure 3b. The elevation patterns of these antennas are formed by the multiple reflection aperture consisting of a large reflector trough and small reflector strip.

The variation of the E plane (elevation) 3 dB beam width and side lobe level resulting from variation in width of the small reflector strip is also shown in Figure 3a for a waveguide fed trough aperture antenna with a vertical aperture, (H), of $1.5 \lambda_0$. The azimuthal radiation patterns are primarily controlled by the width of the azimuthal aperture and are, in the case of the sectoral horn, similar to those of the horn without the multiple reflection aperture.

The construction of the proposed linear array antenna is shown in Figure 3c. In this application a linear slotted array is used to feed the multi-reflection aperture which is formed by a trough shaped large reflector and a small reflector strip running the whole length of the azimuthal aperture, similar to that of the sectoral horn in Figure 3b. Two parallel plates placed one each side of the slot elements provide a grating lobe filter and also effectively "insert" the linear array feed into the optimum position between the plates. The grating lobe filter in this case is by necessity short, $\approx \frac{\lambda_0}{4}$ because of its dual purpose, but effective suppression of the grating lobes for displaced or inclined slot elements is still obtained. This is because additional suppression of the unwanted radiation mode that forms the grating lobes is obtained by its multiple passage back and forth between the plates.

An important point of a linear array antenna utilising this type of aperture is that the grating lobe filter does not add to the depth of the antenna, but that the filter is contained within the multiple reflection aperture.

5. THE EXPERIMENTAL ANTENNA

A vertically polarised linear array antenna of 24 shunt displaced slots and designed for use in X band at 9.4 GHz was used for the experimental tests. A multiple reflection aperture, (hereafter shortened to MRA), similar to that shown in Figure 3c was fitted to the array. The aperture height (H) was $2\lambda_0$ and the width of the small reflector strip (W), $0.3 \lambda_0$. The spacing between the reflectors was made $0.6 \lambda_0$.

The azimuthal radiation patterns of the linear array were plotted initially with no grating lobe filter or vertical beam forming devices (flare or MRA) fitted. These patterns are shown in Figure 4a for two conditions, firstly, with the array waveguide mounted such that its slotted wall was normal to the line of sight of the incident energy from the transmitter (0° Elevation tilt). Secondly, the azimuthal pattern was taken with the array tilted back by 15° in the vertical plane in order to show the grating lobes normally found with arrays using displaced slots. The grating lobes are situated above and below the horizontal plane passing through the centre of the main beam.

From Figure 4a it is seen that the measured levels of the highest side lobes of the antenna in the azimuthal plane are of the order of -26 to -27 dB down on the main beam at 0° Elevation. On tilting the antenna back 15°, the grating lobes appear at $\pm 38^\circ$ with levels of -23 and -26 dB respectively, for the left and right hand sides. The patterns shown in Figure 4b are of the same linear array antenna, but fitted with the MRA described above. Measured patterns for antenna elevation tilts of 0° and 15° are presented. It is seen that the highest side lobes have increased on the left-hand side of the beam have increased by about 2 dB on fitting the MRA. With the antenna tilted back 15° the left-hand side grating lobe (at 38°) has increased by 2 dB to 33.5 dB, but this level is still well below the general side lobe level of the antenna. This latter pattern with the antenna tilted back 15° also shows that adequate suppression of the grating lobes has been obtained even with the very short filter plates surrounding the waveguide slots.

6. COMPARISON OF ANTENNAS

The antenna shown in figure 1a was designed for L band (Reference 5) and a cross section of it is shown in Figure 5a, together with its dimensions in generalised terms (λ_0). The mid-band elevation and azimuthal radiation patterns of this antenna are also shown. Comparison is made with the patterns obtained from an X band MRA antenna, Figure 5b. It can be seen that the aperture dimensions as well as the amplitude and phase distributions give radiation patterns with similar characteristics in both the elevation and azimuthal planes to those of the L band antenna with flared aperture.

The azimuthal patterns of both arrays have main beam widths and side lobes of similar proportions. The elevation patterns have similar main beam widths but the MRA antenna has considerably lower side lobes. A table is presented (also in Figure 5b) showing the estimated percentage saving in cross sectional size and weight obtainable by use of a MRA antenna in place of a flared aperture design. Savings in overall depth of the antenna (L) of approximately 72%, including the array waveguide, are possible. A small reduction (10%) in aperture height (H) is also possible. The weight reduction, assuming construction from similar gauge metal for both antennas is approximately the same as the reduction in the cross sectional size. In practice an extra array support structure might be needed to give a similar order of mechanical stiffness along the length of the MRA antenna to that of the flared antenna. Allowing for this extra structure the weight of the MRA antenna should still not be greater than 50% of that of the flared antenna.

Figure 6a shows two MRA arrays mounted back to back as proposed in Paragraph 1. Reductions of 44% are estimated in total array depth (2L), compared with a single flared antenna. The weight of the dual array should be of the same order as a single flared array.

7. SUGGESTED ANTENNA CONSTRUCTION

Three possible methods of constructing the antenna in a practical form are shown in Figure 6b. The large and small reflectors forming the array aperture can be spaced apart using a solid block of low loss dielectric, rigid plastic foam or a honeycomb laminate. The slotted waveguide array together with grating filter plates are shown inserted into a groove cut in the centre of the blocks, and are attached to the rear of the large reflector.

If a solid block were used the slots lengths and coupling factors would have to be designed to be resonant when radiating into the block. Also the spacing between the

reflectors would have to be reduced by $\frac{\lambda d}{0.6}$ (where λd is the wavelength in the dielectric of the block) in order that optimum multiple reflection conditions could be obtained. Both reflectors could be applied to the blocks or tube using plating techniques.

8. CONCLUSIONS

This report describes a method of reducing the size and weight of linear array antennas that use a flared aperture to form the elevation beam. These reductions are obtained by replacing the flared aperture design by a multiple reflection aperture, thereby giving large reductions in antenna depth, cross-sectional area and weight of the array.

Estimations of the order of reductions to be expected show that savings in size and weight of 50% - 70% might be possible and that this would fulfil most of the possible advantages listed in the Introduction. A limitation of the MRA antenna is that at the present time it can only replace antennas with an operating bandwidth of 10% or less.

9. REFERENCES

1. A C Large. "A Linear Array Using Double Post Fed Slots". ASWE Laboratory Note XRA-67-2. (UNCLASSIFIED).
2. H W Ehrenspeck. "The Backfire Antenna, a New Type of Directional Line Source". Proc IRE, Vol 48, No 1, January 1960, pp 109-110.
3. H W Ehrenspeck. "The Short Backfire Antenna". Proc IEEE, Vol 53, No 6, August 1965, pp 1138-1140.
4. A C Large. "The Application of a Waveguide Feed to a Short Backfire Antenna". ASWE Technical Report TR-73-16. (UNLIMITED).
5. J McDougall and W D Delany. "A Experimental 20 ft Vertically Polarised L-band Linear Array for use with Pulse Doppler Radar". ASWE Technical Report TR-70-6. (UNLIMITED).

ALTERNATIVE METHODS OF FORMING THE ELEVATION BEAM OF A LINEAR ARRAY ANTENNA.

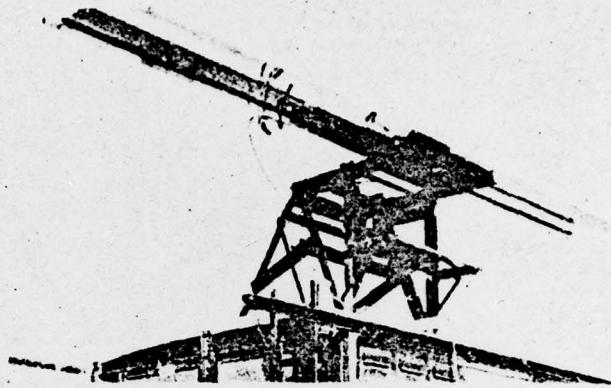
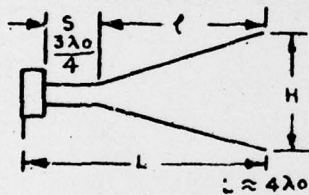

FIG. 1a. A TYPICAL LINEAR ARRAY ANTENNA WITH FLARED APERTURE.



ADVANTAGES.

1. SIMPLE DESIGN.
2. REQUIRES ONLY ONE PRECISION SLOTTED ARRAY.
3. ELEVATION BEAM WIDTH CAN BE VARIED CONTINUOUSLY WITHIN LIMITS.

DISADVANTAGES.

1. TO OBTAIN GOOD ELEVATION PATTERNS FLARE LENGTH $\geq 3H$.
2. FLARED DESIGN GIVES MUCH LARGER CROSS SECTIONAL AREA AND WEIGHT THAN STACKED ARRAYS.

FIG 1b. FLARED SECTION ARRAY.

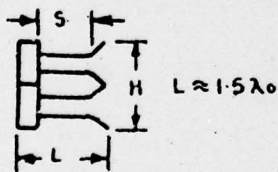

1. SMALLER CROSS SECTIONAL AREA.
2. DECREASE IN WEIGHT OVER FLARED DESIGN.

1. REQUIRES MORE THAN ONE PRECISION SLOTTED ARRAY
2. ELEVATION BEAMWIDTH CAN ONLY BE VARIED IN STEPS, DEPENDS ON NUMBER OF STACKED ARRAYS.

FIG. 1c. STACKED ARRAYS (DISPLACED OR INCLINED SLOTS)



1. VERY SMALL ARRAY CROSS SECTION.
2. NO GRATING LOBE FILTER.
3. LIGHTWEIGHT.

BOTH DISADVANTAGES AS FIG. 1c ABOVE.

FIG. 1d. STACKED ARRAYS (IRIS FED SLOTS)

ANTENNAS WITH MULTIPLE REFLECTION OR "BACKFIRE" APERTURES

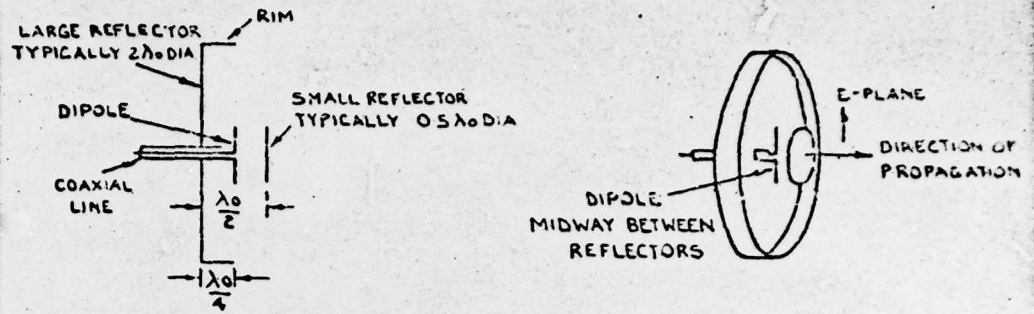

FIG. 2a. SHORT BACKFIRE ANTENNA WITH DIPOLE FEED

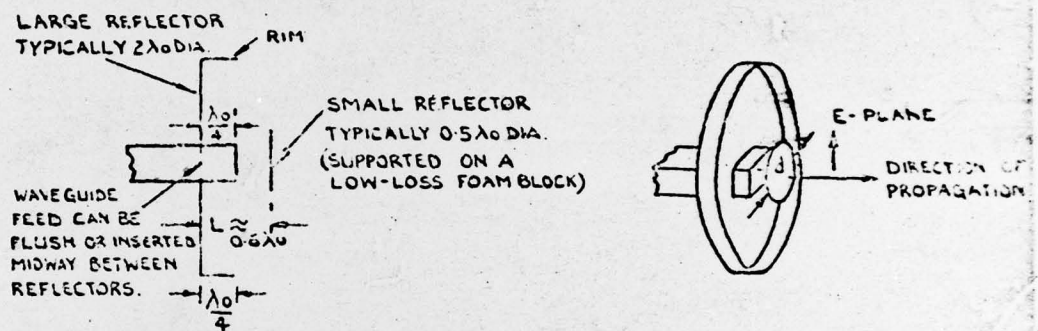

FIG. 2b. WAVEGUIDE FED VERSION OF ANTENNA

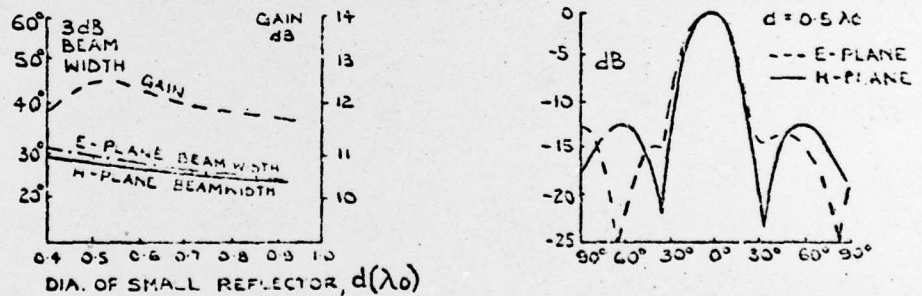

FIG. 2c. RADIATION PROPERTIES OF ANTENNA SHOWN IN FIG. 2b (INSERTED FEED)

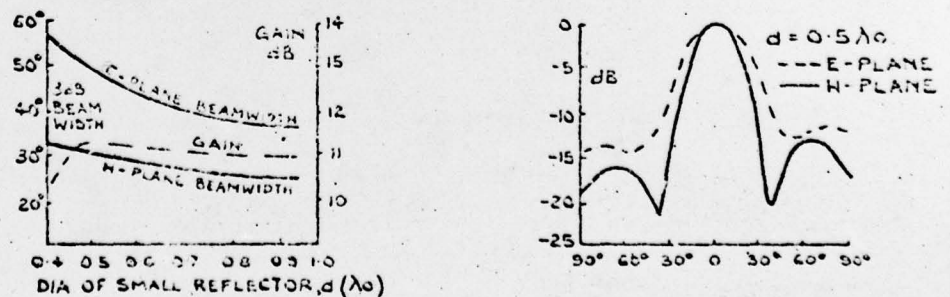

FIG. 2d. RADIATION PROPERTIES OF ANTENNA SHOWN IN FIG. 2b (FLUSH FEED)

MULTIPLE REFLECTION APERTURES APPLIED TO LINEAR ANTENNAS

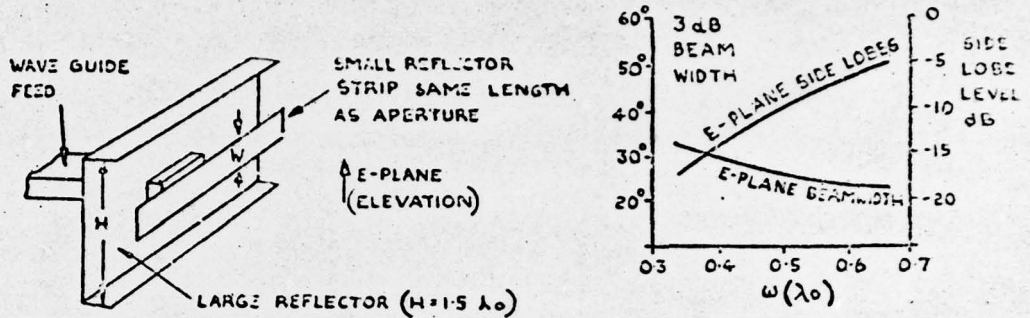

FIG. 3a. WAVEGUIDE FED ANTENNA WITH TROUGH MULTI-REFLECTION APERTURE

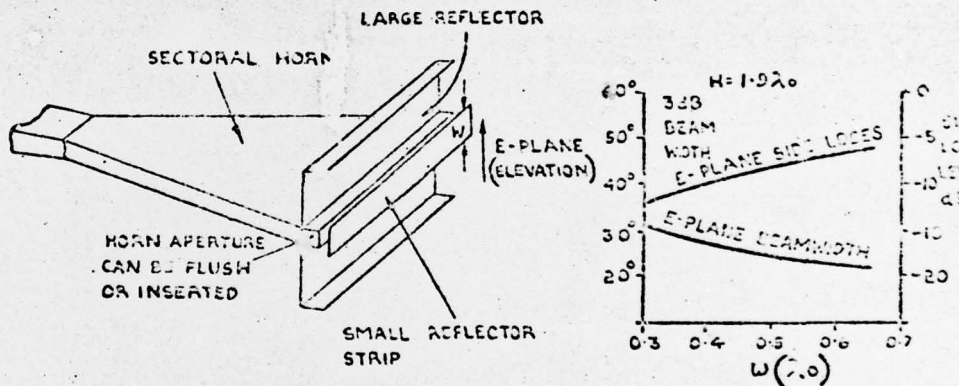

FIG. 3b. H PLANE SECTORAL HORN WITH MULTI-REFLECTION APERTURE.

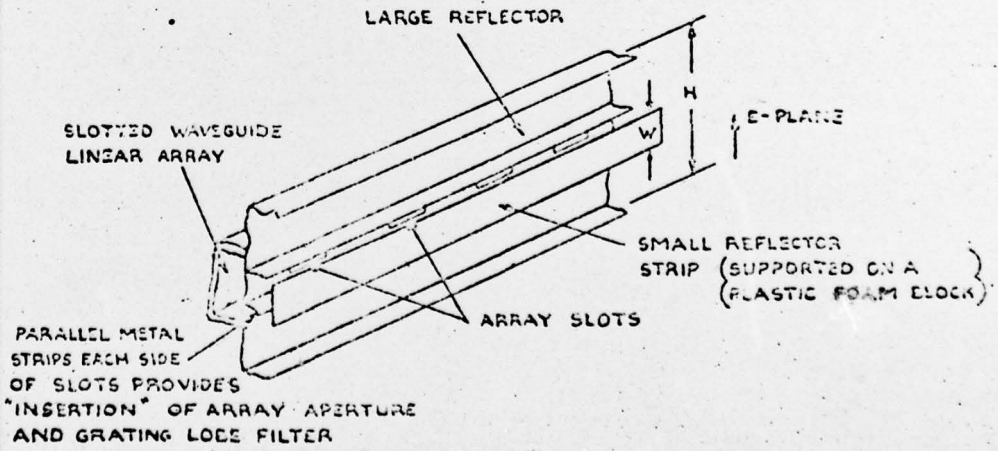

FIG. 3c. SECTION OF SLOTTED LINEAR ARRAY WITH MULTI-REFLECTION APERTURE

AZIMUTHAL RADIATION PATTERNS

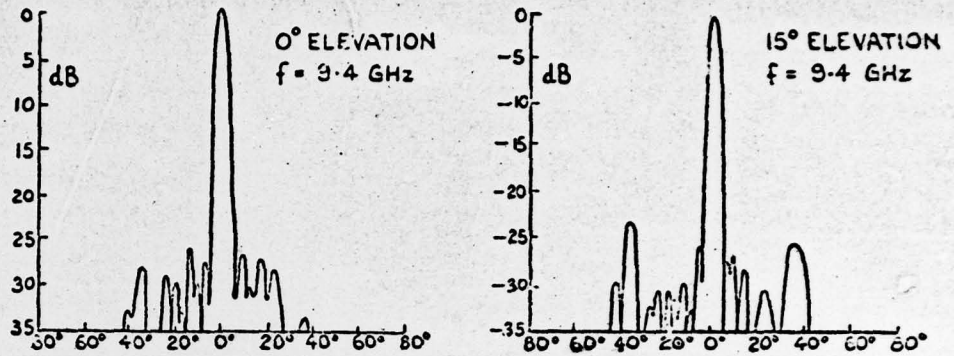

FIG 4a RADIATION PATTERNS OF A LINEAR ARRAY OF 24 SLOTS

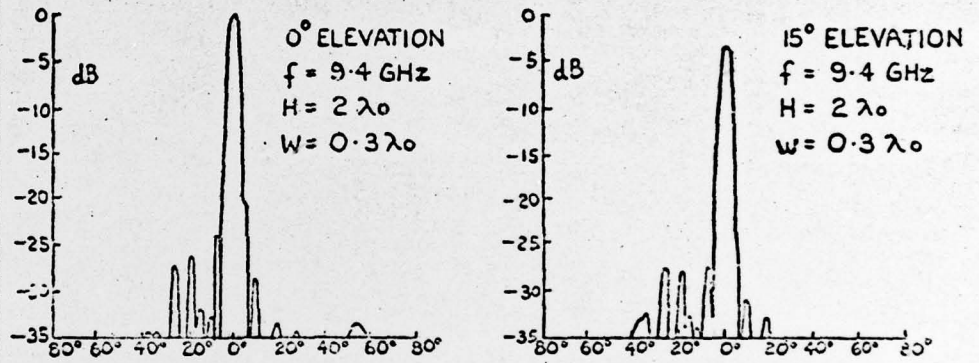

FIG.4b RADIATION PATTERNS OF ARRAY WITH MULTIPLE REFLECTION APERTURE

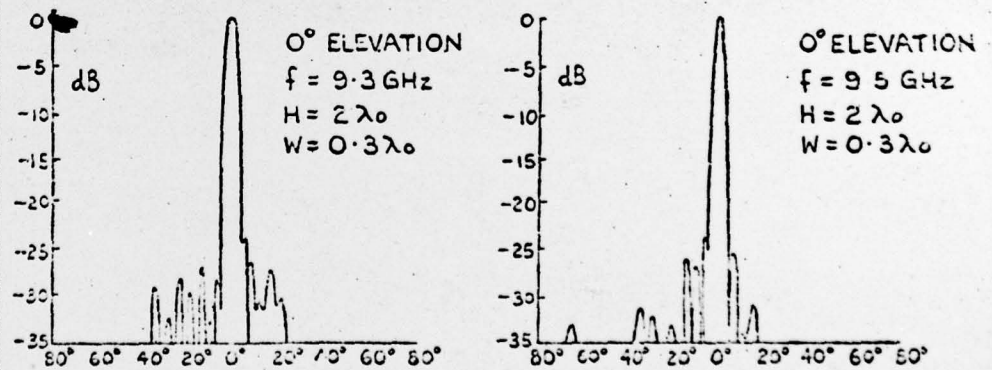
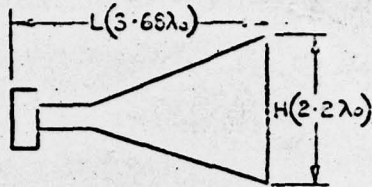
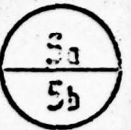

FIG 4c RADIATION PATTERNS OF ARRAY WITH MULTIPLE REFLECTION APERTURE

COMPARISON OF LINEAR ARRAYS WITH FLARED AND
AND MULTIPLE REFLECTION APERTURES



SECTION OF ANTENNA OF FIG 1a

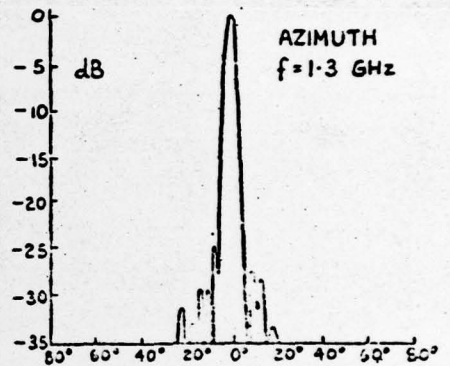
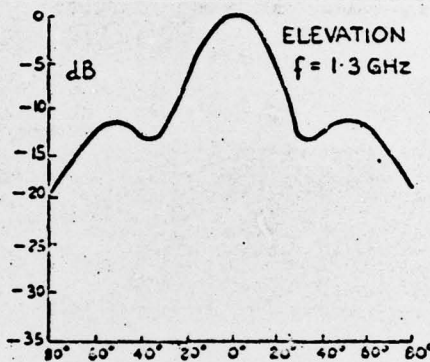
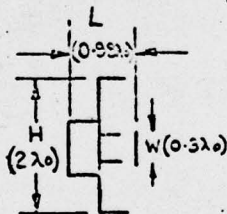

FIG. 5a RADIATION PATTERNS OF ANTENNA WITH FLARED APERTURE

ESTIMATED REDUCTIONS IN SIZE AND AND WEIGHT
OF MRA ANTENNA OVER FLARED ANTENNA DESIGN.



SECTION OF MRA ANTENNA

DIMENSION	REDUCTION
ANTENNA DEPTH (L)	73%
ANTENNA HEIGHT (H)	10%
AREA OF ANTENNA CROSS SECTION	68%
ANTENNA WEIGHT	≈ 50%

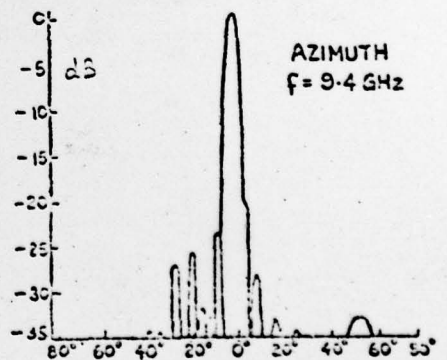
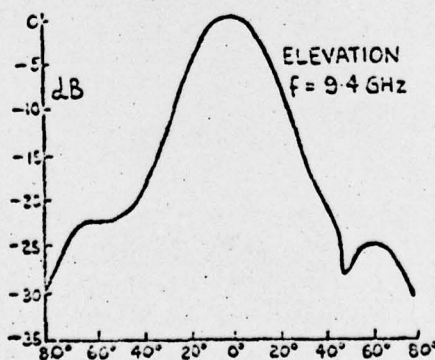
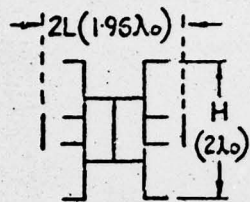

FIG 5b. RADIATION PATTERNS OF ANTENNA WITH MULTIPLE
REFLECTION APERTURE

ESTIMATED REDUCTIONS OF BACK TO BACK MRA ANTENNAS OVER A SINGLE FLARED ANTENNA

6a
6b



DIMENSION	REDUCTION
ANTENNA DEPTH (2L)	44%
ANTENNA HEIGHT (H)	10%
AREA OF ANTENNA CROSS SECTION	≈ 34%
ANTENNA WEIGHT	≈ SINGLE FLARED ANTENNA

FIG. 6a COMPARISON OF BACK TO BACK MRA ANTENNAS WITH FLARED ANTENNA

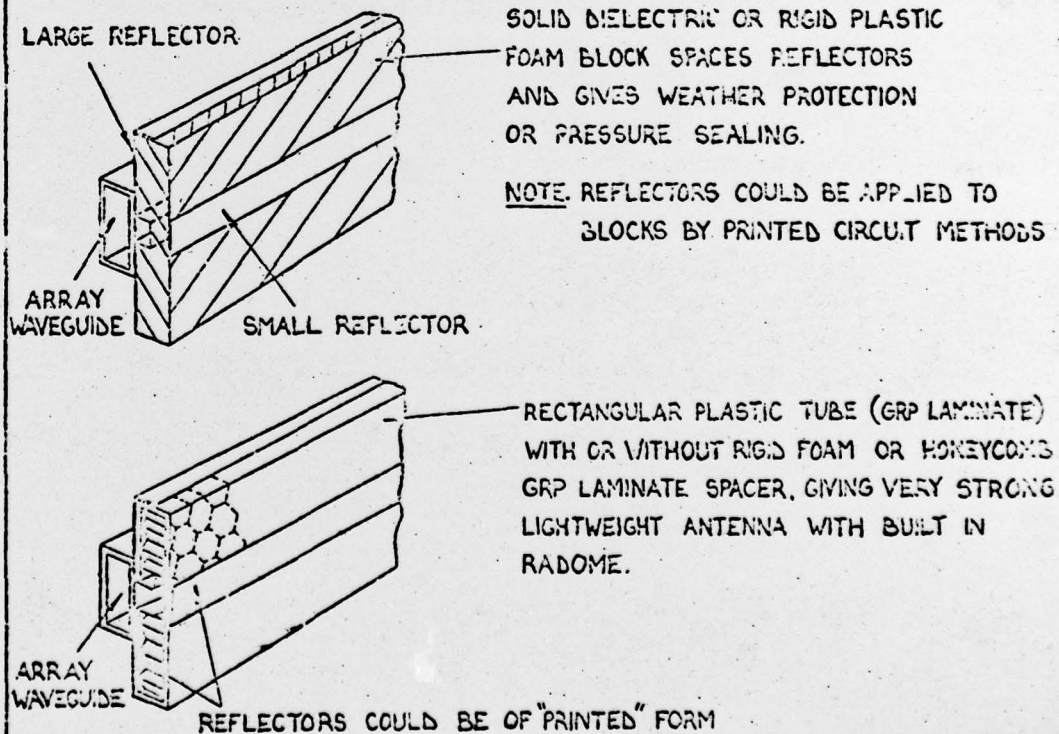

FIG. 6b. POSSIBLE METHODS OF ANTENNA CONSTRUCTION

DOCUMENT CONTROL SHEET

Overall security classification of sheet **UNLIMITED**

(As far as possible this sheet should contain only unclassified information. If it is necessary to enter classified information, the box concerned must be marked to indicate the classification eg (R),(C) or (S).)

1. DRIC Reference (if known) BR 39420	2. Originator's Reference TR-74-2	3. Agency Reference	4. Report Security Classification UNLIMITED
5. Originator's Code (if known) 012000	6. Originator (Corporate Author) Name and Location ADMIRALTY SURFACE WEAPONS ESTABLISHMENT PORTSMOUTH HANTS UK		
5a. Sponsoring Agency's Code (if known)	6a. Sponsoring Agency (Contract Authority) Name and Location		
7. Title A LINEAR ARRAY ANTENNA OF GREATLY REDUCED SIZE AND WEIGHT			
7a. Title in Foreign Language (in the case of translations)			
7b. Presented at (for conference papers). Title, place and date of conference			
8. Author 1. Surname, initials A C LARGE	9a. Author 2	9b. Authors 3, 4...	10. Date pp 5 ref February 1974
11. Contract Number	12. Period	13. Project	14. Other References
15. Distribution statement Via DRIC TP/A Director ASWE			
Descriptors (or keywords)			
continue on separate piece of paper if necessary			
Abstract A new type of antenna design is described that could be applied to radar antennas for surveillance or navigational purposes. Compared with antennas in current use large reductions, typically 50-70% in cross sectional size and overall weight, should be obtainable with this antenna design.			