

AD-A076 319

ELECTROSPACE SYSTEMS INC RICHARDSON TEX
PRELIMINARY DESIGN AND VISUALIZATION PLAN, 30 TO 80 MHX VHF BRO--ETC(U)
APR 72
ER-72-10

F/G 9/5

DAAB07-72-C-0137

NL

UNCLASSIFIED

1 OF 2
ADA
076319

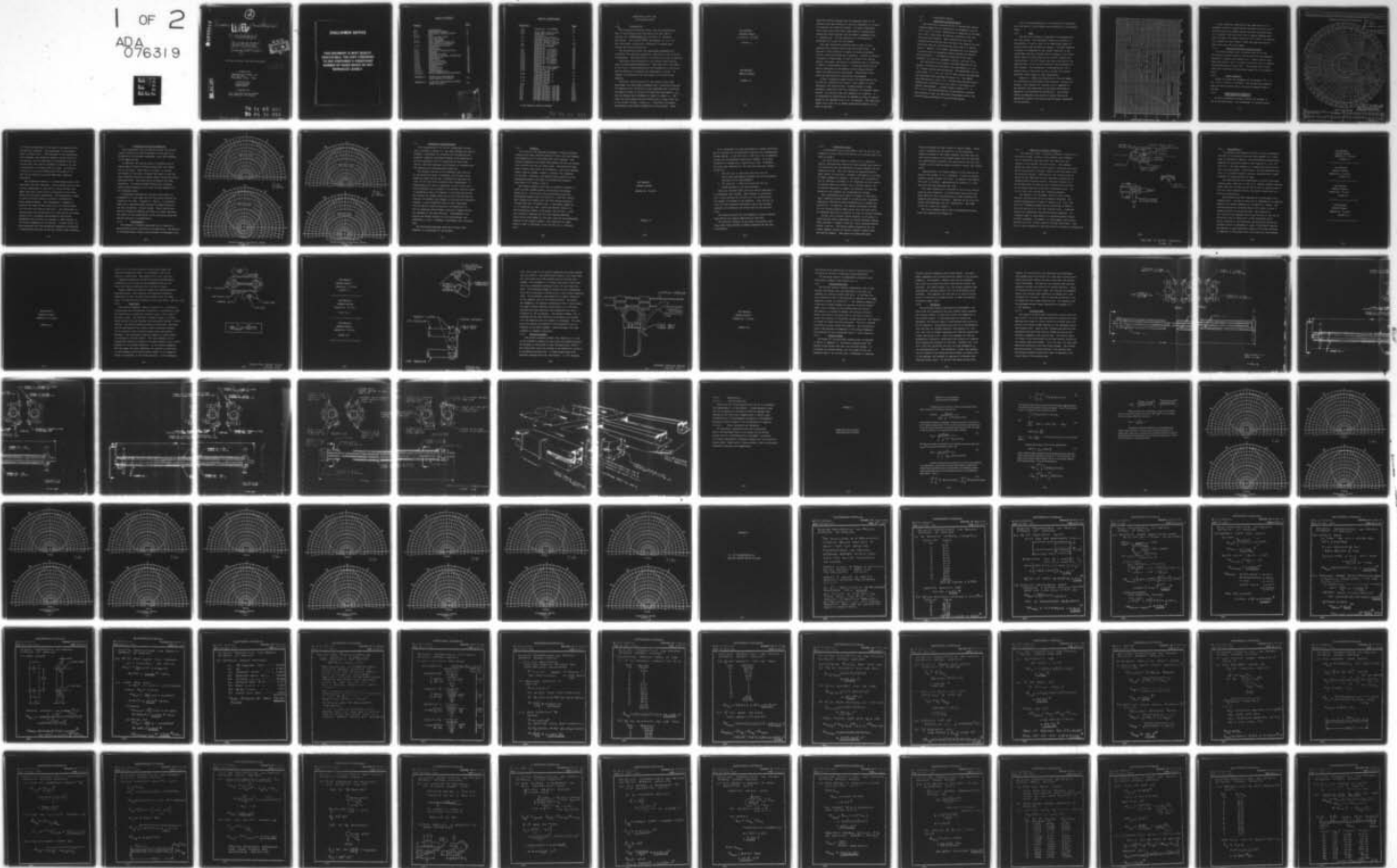

A076319

2

11

28 April 1972

LEVEL

Document No. ER-72-10

14

6

PRELIMINARY DESIGN AND
VISUALIZATION PLAN

30 to 80 MHz VHF Broadband
Directional Log Periodic
Antenna - ESI Type 42A-1

Contract No. DAAB07-72-C-0137

15

DDC
RECEIVED
NOV 7 1972
E

(DD Form 1423 Data Item A001 Submittal)

12 100

Prepared By:

ELECTROSPACE SYSTEMS, INC.
P.O. Box 1359
Richardson, Texas 75080

DDC FILE COPY

DISTRIBUTION STATEMENT

Approved for public release;
distribution unlimited.

Prepared For:

U.S. Army Electronics Command
Fort Monmouth, New Jersey

79 11 07 032
79 05 11 013

390 654

JOB

DISCLAIMER NOTICE

**THIS DOCUMENT IS BEST QUALITY
PRACTICABLE. THE COPY FURNISHED
TO DDC CONTAINED A SIGNIFICANT
NUMBER OF PAGES WHICH DO NOT
REPRODUCE LEGIBLY.**

TABLE OF CONTENTS

<u>Section</u>		<u>Page</u>
1.0	INTRODUCTION	1
2.0	PRELIMINARY DESIGN	4
2.1	Electrical Characteristics	4
2.1.1	Gain	5
2.1.2	Front-to-Back Ratio and Side Lobes	7
2.1.3	Input Impedance	7
2.1.4	Power Handling Capability and Lightning Protection	7
2.1.5	Transmission Line and Connectors	10
2.1.6	Polarization	10
2.2	Mechanical Characteristics	13
2.2.1	Elements	14
2.2.2	Telescoping Joint	17
2.2.3	Feedline to Element Connections	19
2.2.4	Boom/Feedline	21
2.2.5	Feed Point	24
2.2.6	Mounting Bracket	28
2.2.7	Transmission Line	31
2.2.8	Antenna Weight	31
2.2.9	Packaging	32
2.2.10	Carrying Case	33
2.2.11	Construction	39
2.2.11.1	Interchangeability	39
2.2.11.2	Parts, Materials and Processes	39
APPENDIX A	Directivity Calculations From Radiation Patterns	A-1
APPENDIX B	30-80 MHz Log-Periodic Antenna Weight Analysis	B-1

Accession For	
NTIS G.A.I.	<input checked="" type="checkbox"/>
DDC TAB	<input type="checkbox"/>
Unannounced	<input type="checkbox"/>
Justification	
By _____	
Distribution/	
Availability Codes	
Dist	Avail and/or special
A	23

LIST OF ILLUSTRATIONS

<u>Figure No.</u>		<u>Page</u>
1-1	Drawing No. 72-11008**	2
1-2	**	2
2-1	Scale Model Directivity	6
2-2	30-80 MHz Dipole LP 1/4 Scale	8
2-3	Vertical Polarization, Voltage Pattern, 155 MHz	11
2-4	Vertical Polarization, Voltage Pattern, 190 MHz	12
2-5	Drawing No. 72-11015**	15
2-6	Feedline to Element Connection	20
2-7	Drawing No. 72-11009**	22
2-8	Drawing No. 72-11010**	22
2-9	Drawing No. 72-11011**	22
2-10	Drawing No. 72-11012**	22
2-11	Drawing No. 72-11007**	23
2-12	Dielectric Boom Clamp	25
2-13	Drawing No. 72-11006**	26
2-14	Drawing No. 72-11004**	26
2-15	Drawing No. 72-11003**	26
2-16	Feedline	27
2-17	Antenna Mounting Bracket	29
2-18	Drawing No. 72-11005**	30
2-19	Boom Section No. 1; Elements Stowed	34
2-20	Boom Section No. 2; Elements Stowed	35
2-21	Boom Section No. 3; Elements Stowed	36
2-22	Boom Section No. 4; Elements Stowed	37
2-23	Carrying Case	38
A-1	Voltage Patterns, 120 MHz	A-5
A-2	Voltage Patterns, 125 MHz	A-6
A-3	Voltage Patterns, 150 MHz	A-7
A-4	Voltage Patterns, 190 MHz	A-8
A-5	Voltage Patterns, 220 MHz	A-9
A-6	Voltage Patterns, 250 MHz	A-10
A-7	Voltage Patterns, 275 MHz	A-11
A-8	Voltage Patterns, 300 MHz	A-12
A-9	Voltage Patterns, 320 MHz	A-13

** See Separate Drawing Package

79 05 11 013

PRELIMINARY DESIGN AND
VISUALIZATION PLAN

1.0 INTRODUCTION

The attached Preliminary Design Plan and Visualization Data is submitted as data Item A001 of DD Form 1423 of Contract No. DAAB07 C-0137 from USA ECOM, Ft. Monmouth, New Jersey. The contract is for development of a 30 - 80 MHz directional log-periodic lightweight, transportable antenna for tactical field use.

The Preliminary Design Plan ~~described in Section 2.0~~ interprets the technical parameters identified in the technical requirements. Each requirement is reduced to an item of material.

Electrical characteristics of the antenna under development are described ~~in Section 2.1~~. Each electrical requirement as set forth in ECOM specification DS-EH-0050A(A) is discussed and the method of satisfying the requirement is shown. No changes or difficulties are anticipated in the electrical approach.

Mechanical characteristics of the antenna array under development are described ~~in Section 2.2~~. Preliminary drawings and sketches with discussion of each component part illustrate the approach taken to satisfy the specified requirements. An initial Antenna Parts Breakdown is shown in Figure 1-1 and shows the relationship of each antenna part to each other and to the antenna system. Figure 1-2 illustrates the general configuration and overall dimensions of the antenna. Minor

SEE SEPARATE
DRAWING PACKAGE
DRAWING NO. 72-11008

FIGURE 1-1

SEE SEPARATE
DRAWING PACKAGE

FIGURE 1-2

mechanical design changes from the approach shown in the proposal have been effected in various components as a result of analyses and trade-off studies. To assure compliance with weight and stress level requirements, a preliminary weight and stress analysis are included in Appendix B and C, respectively. The new approach is illustrated and described with logic for the change.

The only identifiable problem area to date is the proposed dull chromium plating per MIL-F-14072A(EL). The plating is very difficult to apply on aluminum surfaces without incurring blistering or peeling. A search of plating literature is being made, as well as contact with several platers throughout the country to determine what is necessary to obtain a satisfactory plate. A trade-off study will be made to determine if the benefits from chromium plating offset the difficulties encountered. Electroless nickel plate per MIL-C-26074 is also being investigated.

A small incongruity exists within the specification DS-EH-0050A(A) regarding the overall 5 foot length of array components and carrying case. Present design of array components works well with the allowable 5'-0" maximum length. However, the carrying case will exceed 5'-0" slightly. It is requested the specification be amended to allow an overall length of the package to be 5'-1 1/2" maximum. The additional length will allow use of foamed polyethylene padding on the ends of the case.

2.0 PRELIMINARY DESIGN

2.1 ELECTRICAL CHARACTERISTICS

The electrical characteristics of log-periodic dipole antennas depend on the combination of parameters (such as the γ ratio, α angle, characteristic impedance of the feed-line, etc.) which must be carefully related to meet the specified requirements. Many combinations have been measured and calculated over the years, the results of which have been used for initiating the first step in a design effort. However, scale model techniques are also employed to assure that the parameters chosen provide the desired characteristics. A carefully constructed scale model produces very accurate impedance, pattern, and gain data.

Two one-fourth scale models have been employed for the purpose of sizing and satisfying the requirements for the 30 - 80 MHz antenna being developed. The parameters for the first model ($\gamma = .877$, $\alpha = 22.5^\circ$) were chosen from measured and calculated data provided by Carrel (1). The models measured patterns, gains, etc., closely approximated Carrel's predictions at mid-band, but fell short of satisfying the overall requirements. A second larger antenna ($\gamma = .9$, $\alpha = 18.7^\circ$) was constructed and the performance improved sufficiently to meet the specified requirements and is the antenna being considered in the prototype design.

The following paragraphs of this Section are concerned with the details of the models and the results of the measurements.

2.1.1 Gain

The gain of an antenna is defined as the directivity less any losses. The measurable losses are usually in a transformer, if one is used, or an associated length of coaxial cable used to feed the antenna. The gain referred to herein is referenced to the output terminals of the transformer and will include only the losses in the transformer since the I^2R losses in the antenna elements are insignificant. The I^2R losses have been calculated to be approximately .02 db for the aluminum tubing proposed for this antenna. The transformer, discussed below, has a maximum loss of less than 0.1 db at 80 MHz with correspondingly lower losses at lower frequencies.

Figure 2-1 shows the directivity of the two models as calculated from principle plane patterns, (E-plane and H-plane - See Figures A-2 through A-13 in Appendix A). The patterns are integrated in the manner discussed in Appendix A to determine the directivity. This method yields considerably more accurate results than using approximate values calculated using half-power beamwidths of the patterns.

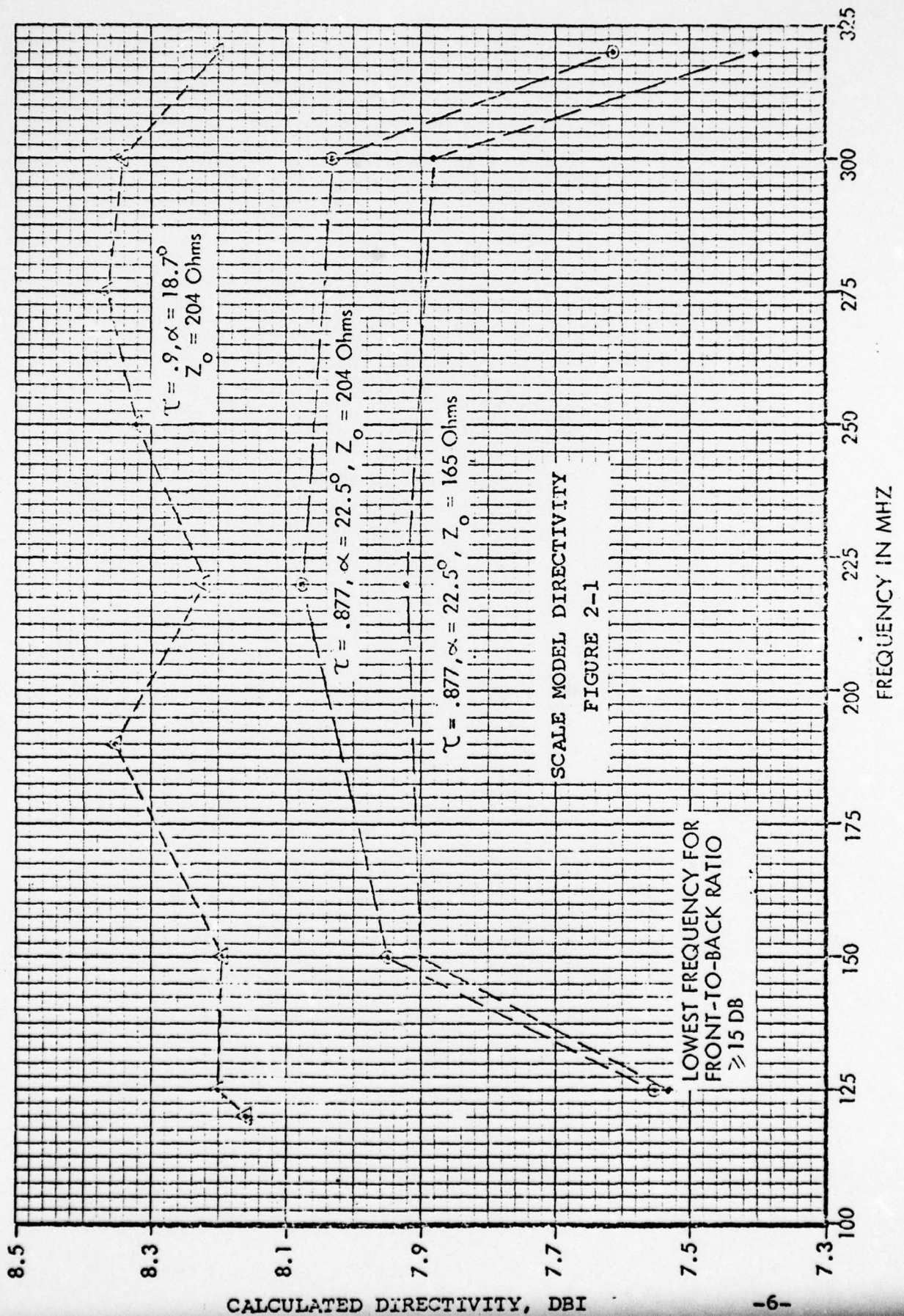

A gain comparison measurement was made using a $\lambda/2$ reference dipole at approximately mid-band for the $\alpha = 18.7^\circ$ structure and this agreed closely with the calculated data. It is apparent from this data that to assure adequate gain over the band, the longer structure ($\alpha = 18.7^\circ$) is required. This antenna was also sized to have the required front-to-back ratio over the entire band.

2.1.2 Front-to-Back Ratio and Side Lobes

The front-to-back ratio is greater than 15 db over the entire frequency range as can be seen from the measured patterns in Figures A-2 through A-13. These patterns were made from the $\alpha = 18.7^\circ$ structure which was sized to produce the desired front-to-back ratio. The antenna has no side lobes and, therefore, automatically meets the 15 db requirement.

2.1.3 Input Impedance

Figure 2-2 shows the impedance of the antenna ($\gamma = .9$, $\alpha = 18.7^\circ$) with $Z_0 = 204$ ohms. This antenna was sized to meet the front-to-back ratio and provide improved VSWR at 120 MHz.

2.1.4 Power Handling Capability and Lightning Protection

An auto-transformer is used to match the antenna to the 50 ohm coax cable. The transformer is located inside

NAME	TITLE 30-80 MHz DIPOLE LP 1/4 SCALE	DWG. NO.
SMITH CHART FORM 530-7560 N	GENERAL RADIO COMPANY, WEST CONCORD, MASSACHUSETTS	DATE 10-6-71

IMPEDANCE OR ADMITTANCE COORDINATES

$\tau = .9$
 $\alpha = 18.7^\circ$
 $Z_0 = 204.2$ feed line
 NORMALIZED
 TO $R_0 = 115$

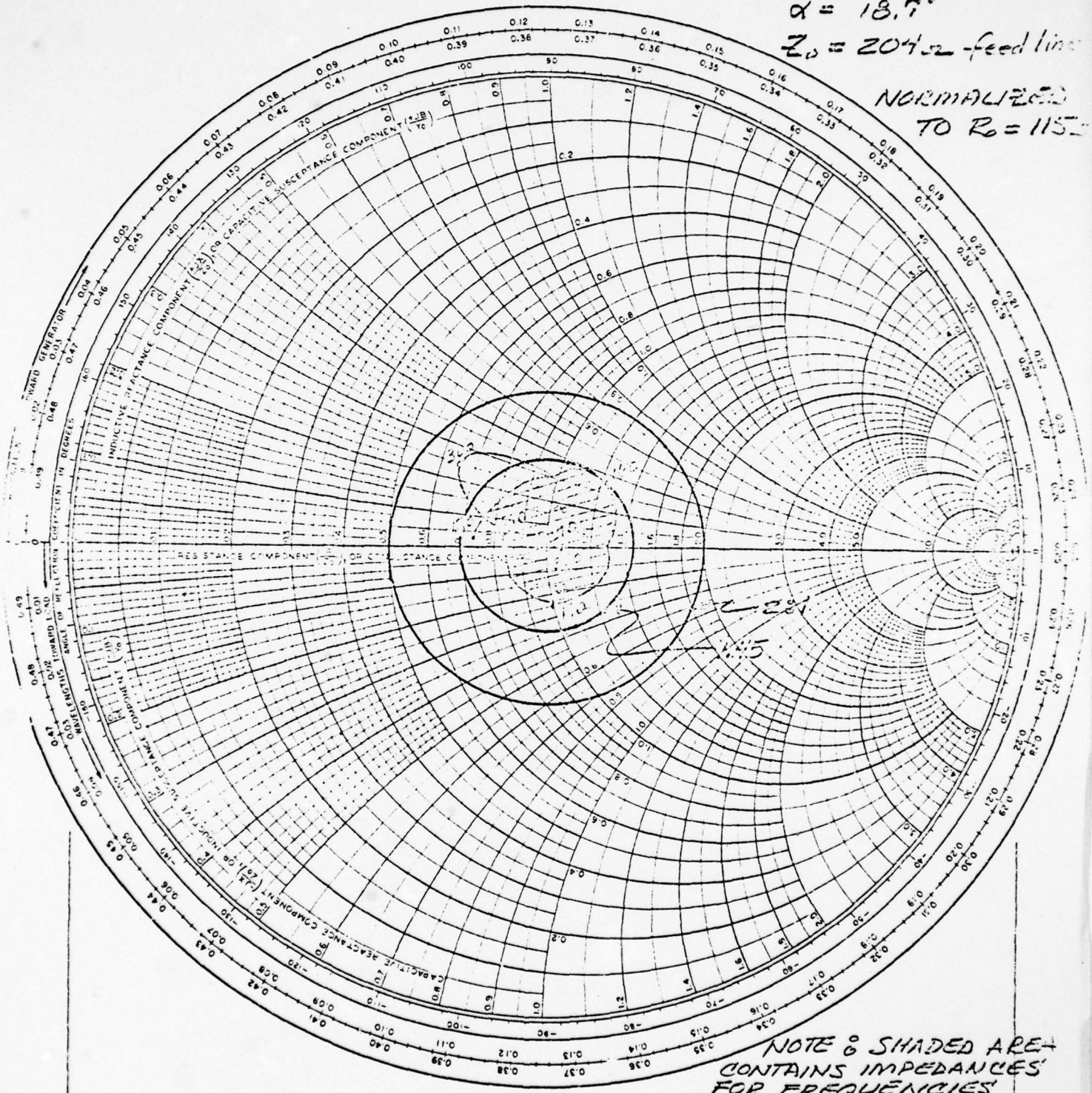

NOTE: SHADED AREA
 CONTAINS IMPEDANCES
 FOR FREQUENCIES
 THROUGH 360 MHz

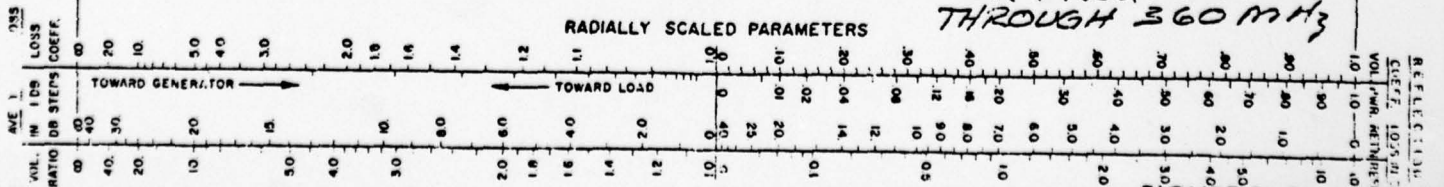

FIGURE 2-2

the lower feedline/boom at the end of the antenna having the smallest elements. The transformer is attached as shown in Figure 2-15 . The secondary of the transformer then provides a dc connection between the two halves of the antenna, and the lower half is connected to the coax shield which must then be grounded to provide a dc path to ground when a dielectric mast is used. An inductive termination is also provided across the booms at the rear of the antenna to provide additional lightning protection.

The transformer design is a proven design used in ESI Type 43A-2 and 43A-5 antennas. The measured insertion loss in this transformer is less than 0.1 db at 80 MHz which means less than 2 watts will be dissipated in the transformer for 100 watts transmitted. The transformer is made of ferrite toroids chosen to provide a conservative power handling design. The transformer is capable of handling 100 watts CW with more than a 2:1 safety factor for the worst flux density condition. The transformer is approximately one and one-half inch long and one and three-eighths inch in diameter and transforms the antenna impedances with virtually no increase in VSWR relative to the nominal impedance of the antenna. In other words, the VSWR associated with the normalized impedances illustrated is essentially that seen at the transformer input terminals.

2.1.5 Transmission Line and Connectors

The transmission line is made of 60 feet of RG 213/U coaxial cable with a male N connector on the end to be connected to the antenna transformer, and a BNC connector on the opposite end.

In addition, the coaxial cable is inserted into rf chokes made of ferrite toroids located near the antenna end of the cable. These sets, or stacks, or toroids are located on the cable to permit the cable to exit the lower feedline boom with a minimum effect on the vertically polarized field. The cable exits the boom at the mast connection. The ferrite chokes effectively "break-up" (electrically speaking) the 10 feet of coax adjacent to the fiberglass mast.

The patterns recorded for the gain calculations of Paragraph 2.1.1 were made with the coax cable exiting the antenna at the rear. Figures 2-3 and 2-4 are patterns made with a simulated cable exiting the model antenna at the mast connection, without chokes. These figures also show the effect of breaking the cable into small sections. The effect of the choked cable on the vertically polarized pattern and gain is insignificant.

2.1.6 Polarization

The antenna is linearly polarized and is capable of being mounted either vertically or horizontally. The details of the polarization fixture are discussed in Paragraph 2.2.6.

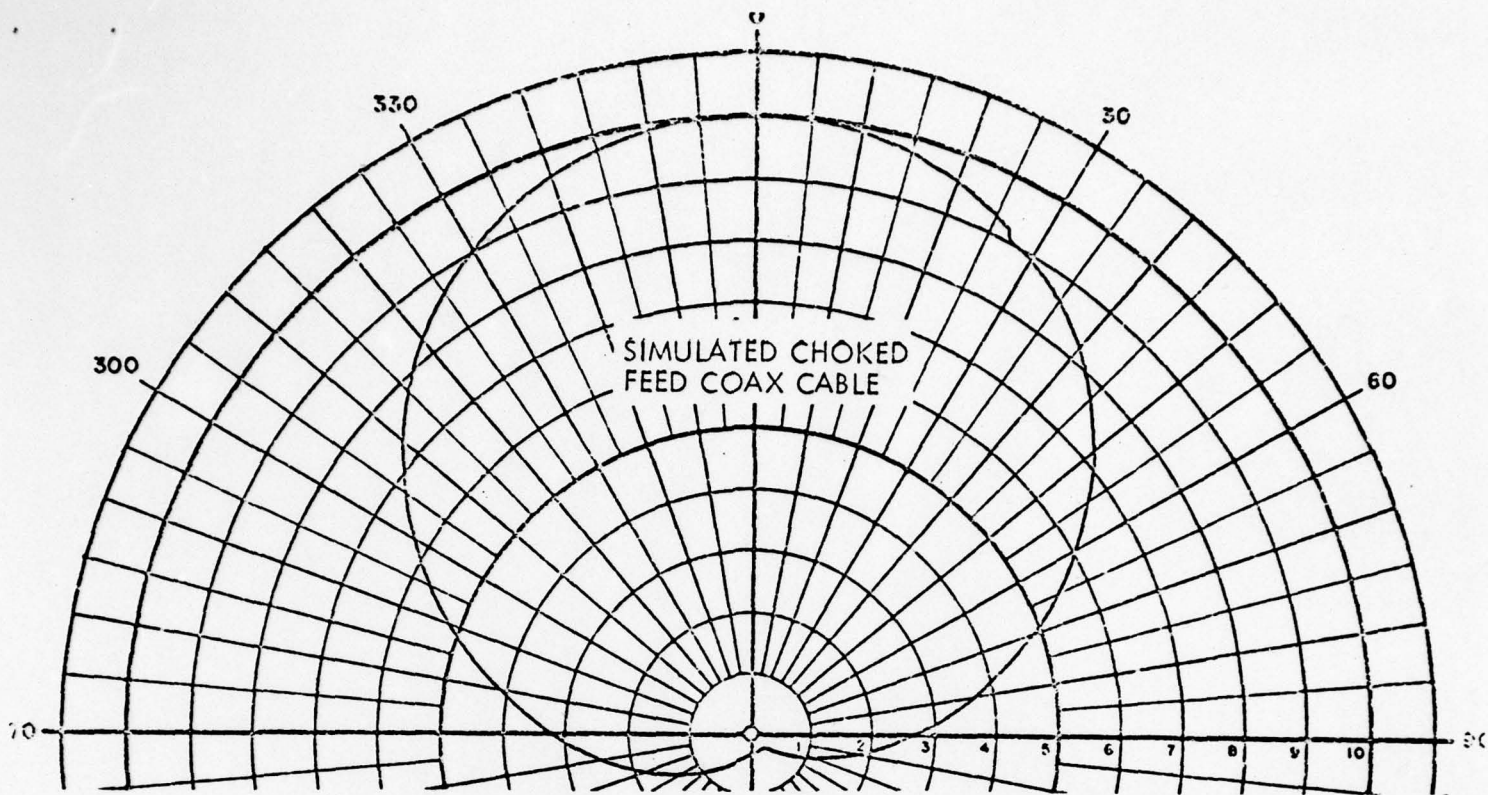

$$\tau = .9$$

$$\alpha = 18.7^\circ$$

$$Z_o = 204 \text{ Ohms}$$

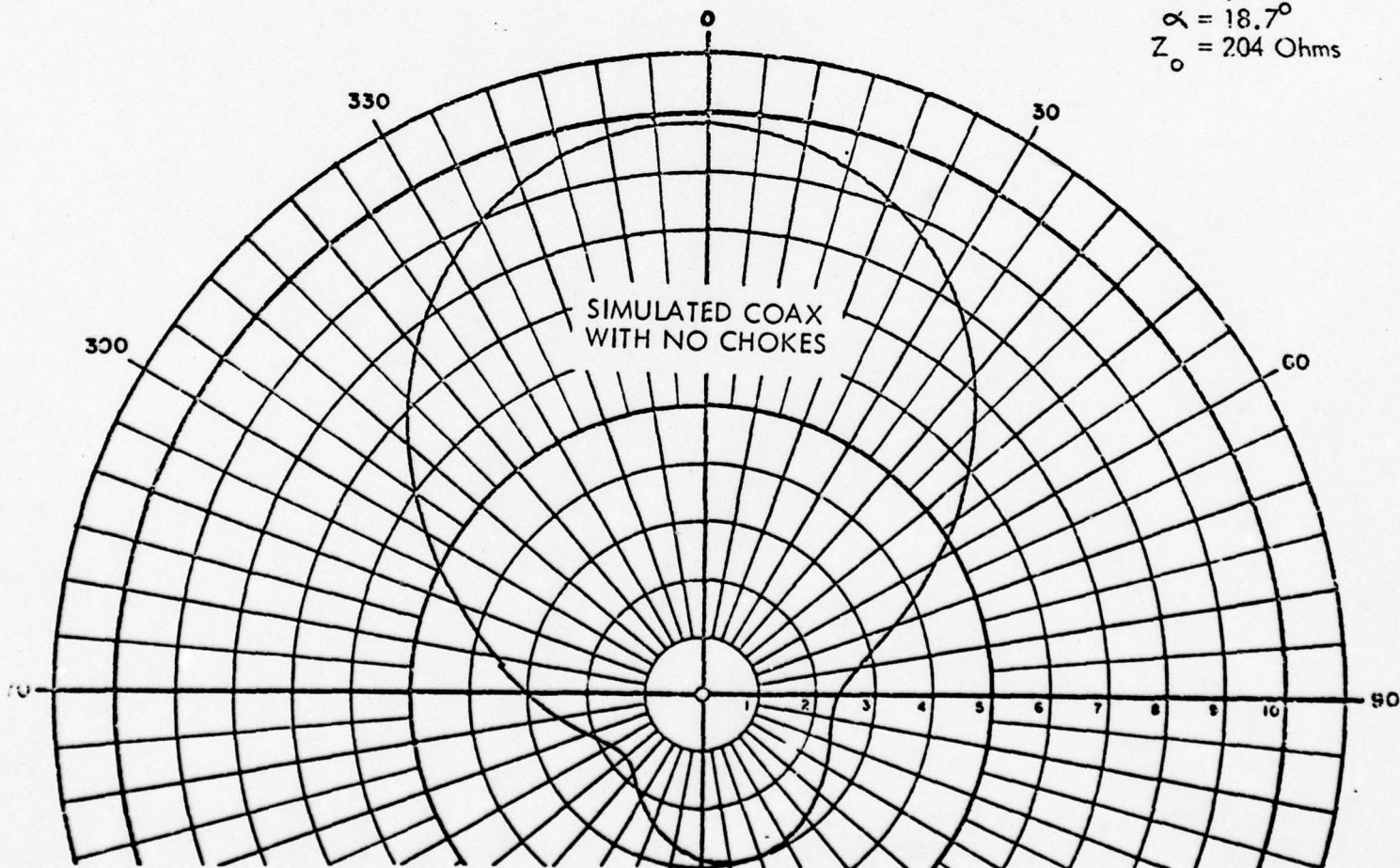

Vertical Polarization, Voltage Pattern, 155 MHz
 FIGURE 2-3

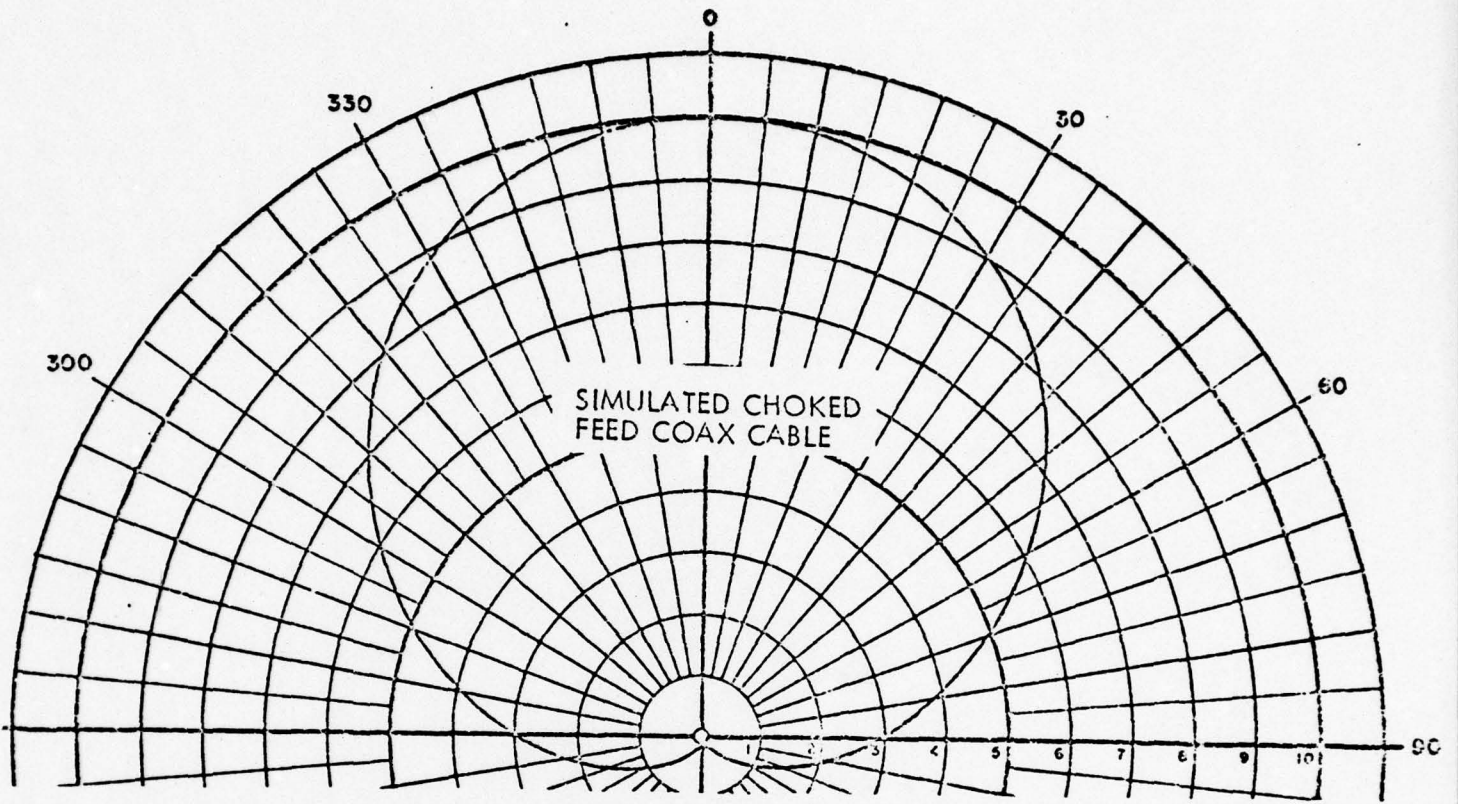

$$\begin{aligned} \gamma &= .9 \\ \alpha &= 18.7^\circ \\ Z_0 &= 204 \text{ Ohms} \end{aligned}$$

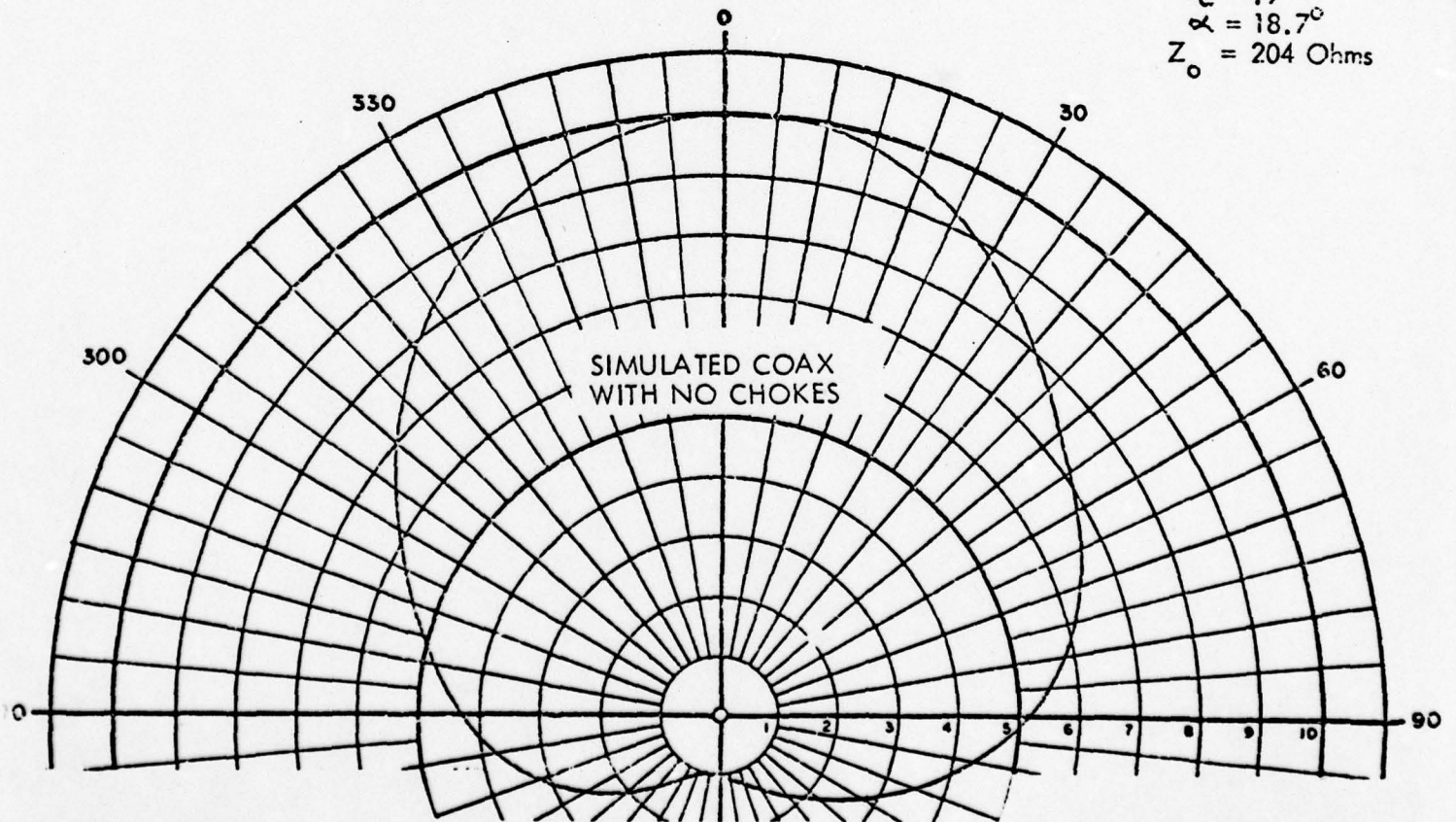

Vertical Polarization Voltage Pattern, 190 MHz
FIGURE 2-4

MECHANICAL CHARACTERISTICS

The transportable 30 to 80 MHz log-periodic antenna array outlined in Figure 1-2 has been designed for ease of assembly, lightweight for handling and transportability purposes, rugged to withstand frequent field handling by military personnel and for transportation over rough terrain, and with materials and finishes to withstand both the operating and non-operating conditions.

The antenna consists of two feedlines that also act as the structural boom, 14 elements, six of which telescope and eight that do not, a bracket for mounting the array to the mast and a coax/feed point subassembly. A telescoping joint that is identical in each of the telescoping members and an element to boom pivot extrusion used to permanently mount the elements to the boom and provide for sliding the element along the axis of the boom and for rotating the element with respect to the boom for convenient stowage. A boom (feedline) section joint fabricated from dielectric material maintains the separation of the two feedlines and provides a positive clamping device for assembly of the boom sections. "Knocked-down" for stowing the device consists of four boom-element sub-assemblies, a coax, a feedpoint subassembly and a carrying case.

The following paragraphs describe in detail each component or subassembly of the antenna.

2.2.1 Elements

As stated in the engineering proposal, tubular aluminum elements have been selected because of their low wind loading and adaptability for telescoping and joint designs. The element ruggedness and weight requirements are the two factors which dictate the size of tubing used. The electrical parameters require that there be 14 elements. The 5-foot package length requires element numbers 1 through 6 to telescope for storage. Therefore, the antenna array consists of six telescoping elements and eight non-telescoping elements (see Figure 2-5, Sheets 1 and 2).

The antenna element sizes must be carefully selected to yield the most rugged antenna, yet maintain the design weight goals. The initial size considered for the non-telescoping elements was 3/8 inch O.D. x .035 wall tubing. When loading the element with the wind loading condition (50 mph wind with 1/4 radial ice), a cantilever length up to 57 inches may be used. Since the maximum length of a non-telescoping element is 48 inches, the 3/8 O.D. x .035 wall tubing is adequate for the wind loading required. Using the 48 inch length of .035 wall tube for the telescoping section of the longest element, then requires the fixed section (next to the boom) to be 3/4 inch O.D. x .058 wall tube.

SEE SEPARATE
DRAWING PACKAGE
DRAWING NO. 72-11015

FIGURE 2-5

It is recognized that the environmental loading conditions are not necessarily the governing conditions for transportable antenna design. A 3/8 inch O.D. x .035 wall tube is adequate to meet the environmental conditions; however, it is more vulnerable to damage than a heavier wall tube. Therefore, the tube sizes selected for use with the prototype configuration are:

1. 3/8 inch O.D. x .058 inch thick wall for the short (non-telescoping) elements and the telescoping sections of the long elements.
2. 3/4 inch O.D. x .058 inch thick wall for the fixed sections of the long elements.

These are standard sizes which are easily adaptable to a telescoping joint design. Each element is reinforced with a short section of 5/8 inch O.D. rod located where the element is clamped to the feedline. This rod acts as a nut for the clamp bolt providing a very high crushing strength and increasing the reliability of the pivoting joint.

The tubing selected for the elements is drawn aluminum, type 6061-T6 per Federal Specification WW-T-789.

The exterior surfaces of the tubes are painted olive drab color number X24087 of Federal Standard 595 per MIL-F-14072A(EL).

2.2.2 Telescoping Joint

A telescoping joint is provided in each of the six long elements to allow stowing the device in a carrying case five feet in length.

The joint design shown in Figure 2-5 is a positive action, self-securing connection which provides good electrical continuity and high mechanical strength between the two element sections. The joint design was selected because every detail is functional, reliable, and requires a minimum of human judgment to operate. The basic joint consists of the two sections of element to be connected, spring contacts to provide electrical contact and a latching action, and two plastic bearings to support and provide a non-galling surface as the elements are telescoped for storage.

This telescoping joint shown in Figure 2-5 was chosen after trade-off studies based on tolerances and clearances required to achieve an easily produced item in production quantities. In addition, this design eliminates the need for the chromium plating deep within the tube which would be extremely difficult to provide in light of current findings.

The new joint (contact latch) consists of two parts, a rigid tubular sleeve containing an annular external locking tooth and bearing support (item 35); and a serrated tubular sleeve (item 34). The latter sleeve consists of six (6) finger segments having an annular internal locking tooth and bearing support. Both parts are fabricated from

beryllium copper and heat treated to spring temper. Dimensional tolerances may be held with little difficulty. Bending stresses of the finger segments are less than one-half yield strength as the finger passes over the lock and are approximately one-fourth the yield point with the joint locked in place assuring ample electrical contact and locking force.

Operationally, the finger segments of the latch do not drag on the element as it is extended. A force of approximately 5 pounds latches the joint. An audible snap signals the joint is latched. Approximately 10 pounds or a light tap with the hand unlatches the joint.

The joint elements are installed on and in the aluminum tubes by soft soldering. An electroless nickel plate per MIL-C-26074 on the tube and contacts allows soldering the elements and prevents corrosion. Bearings of the joint are Teflon tube diagonally cut for installation. See items 32 and 33, Figure 2-5, Sheet 2.

The joint assembly may be easily disassembled without tools for cleaning and inspection.

2.2.3 Feedline to Element Connection

The feedline (boom) to element connection consists of a two-piece hinged, aluminum, pivot-bracket held together with a captivated wing nut screw that captivates the element to the bracket (see Figure 2-6). This bracket design has been chosen to allow greater tolerances of mating parts and provides a stronger support since the element does not require slotting. Additionally, the locating keys or guides on the feedlines are not required, allowing use of standard drawn aluminum tubing. The pivot brackets are positioned along the boom by .312" diameter holes drilled at the proper position along each transmission line. One hole in each line locates each radiating element.

The elements are unclamped, moved to their stowed position locating hole and re-clamped as proposed. The stowed configuration is shown in Figures 2-19, 2-20, 2-21, and 2-22. Element brackets can be fabricated of 6061T-6 aluminum extrusions or cast 356 aluminum alloy. Trade-off studies will determine the most economical approach. An in-depth study is being made of the chromium plated contact surfaces proposed. At present, it would appear that contact surfaces can have a final chemical film per MIL-C-5541. This film is very resistant to corrosion and will conduct RF frequencies.

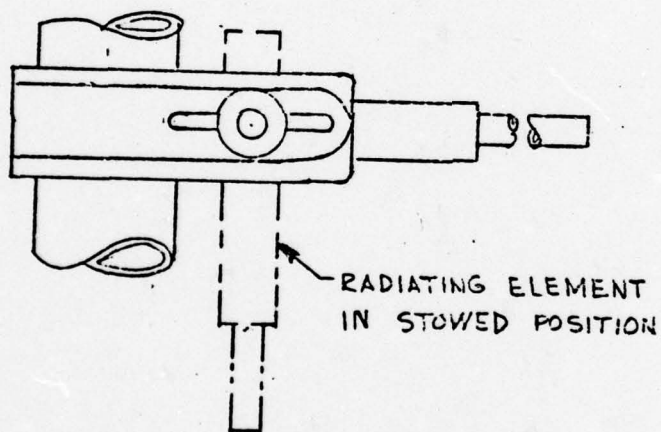
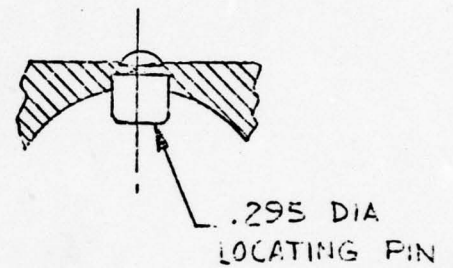
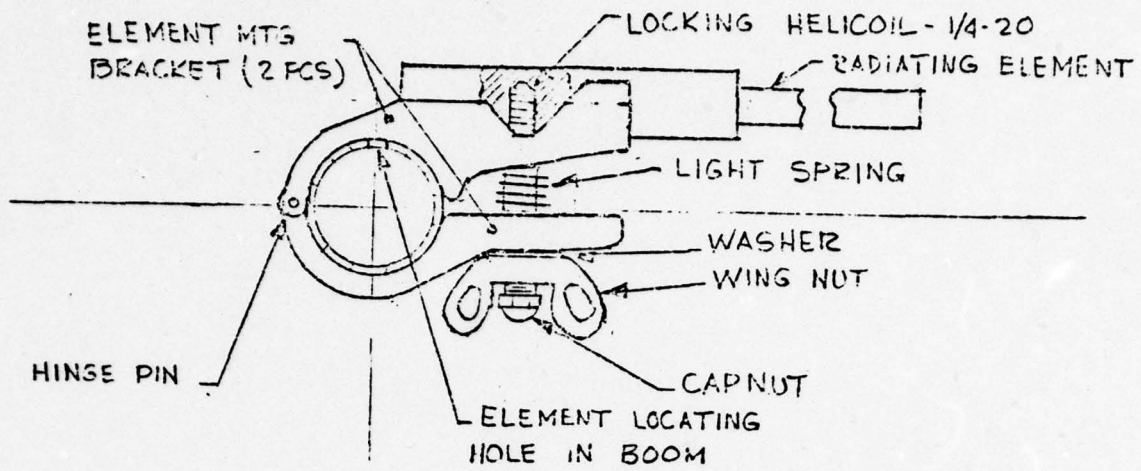

2.2.4 Boom/Feedline

The antenna boom/feedline consists of four telescoping sections of two parallel aluminum tubes spaced 4.13 inches apart by dielectric spacers. The boom/feedline mechanically supports the radiating elements (see Figures 2-7, 2-8, 2-9, and 2-10). The boom connects to a supporting mast through a cast aluminum bracket. Electrically, the boom/feedline functions as a balanced feedline having a characteristic loaded impedance of approximately 125 ohms.

The boom sections are constructed of 6061T-6 structural aluminum tube 1.500 O.D. x .058 wall. Maximum bending stresses under wind and ice load are low as the boom is proportioned to have low static deflection when the array is positional for vertical polarization.

Boom sections are held together by a telescoping overlapping joint. One end of each tube is expanded out to approximately 1.515 inside diameter for a length of 3 inches. The expanded portion is slotted axially 2.50 inches to allow a clamping action on the mating tube. See Figure 2-11. The inside of the expanded portion and outside of the end of the mating tube is electroless nickel plated per MIL-C-26074 to provide a hard corrosion and gall-free connection. Clamping action is provided by a pair of dielectric spacers and results in good electrical contact of the boom sections. In addition to frictional force, the tubes are held together

SEE SEPARATE
DRAWING PACKAGE
DRAWING NO. 72-11009
FIGURE 2-7

SEE SEPARATE
DRAWING PACKAGE
DRAWING NO. 72-11010
FIGURE 2-8

SEE SEPARATE
DRAWING PACKAGE
DRAWING NO. 72-11011
FIGURE 2-9

SEE SEPARATE
DRAWING PACKAGE
DRAWING NO. 72-11012
FIGURE 2-10

SEE SEPARATE
DRAWING PACKAGE
DRAWING NO. 72-11007

FIGURE 2-11

axially by a .375 dia stainless steel quick-release pin inserted through each tube. All hardware on each boom section is captivated. See Figures 2-12, 2-13, and 2-14.

Improper assembly of the boom sections is prevented by orientation of the slots on the expanded portion of the tubes and dimples protruding from the mating tubes.

Spacer clamps are injection molded from glass-reinforced phenylene oxide. This material has excellent dielectric properties, as well as high tensile modulus and low creep rate. The resin can be obtained in olive drab color. See Fig. 2-15.

2.2.5 Feed Point

The antenna feedpoint, shown in Figure 2-16, consists of a feed-strap and a transformer contained in a cylindrical aluminum housing with a feed-thru insulator output, and a type "N" connector input. The feed-thru insulator output is a brass, nickel plated 1/4 inch diameter stud protruding through a Teflon bushing. The Teflon bushing provides for excellent insulation and the resilience of the Teflon allows sufficient flexure of the feed-thru stud to prevent undue strain and possible breakage. The transformer aluminum housing is nickel plated in accordance with MIL-C-26074. The outer diameter of the transformer housing is nominally the same diameter as the inside diameter of the antenna feedlines. At the antenna feedpoint, both the upper and lower feedlines are slotted to allow them to have clamping action when element number 14 is clamped on either the extended or the stowed position. In the feedpoint

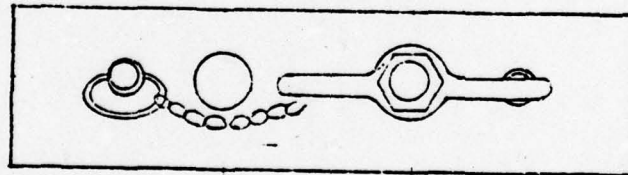
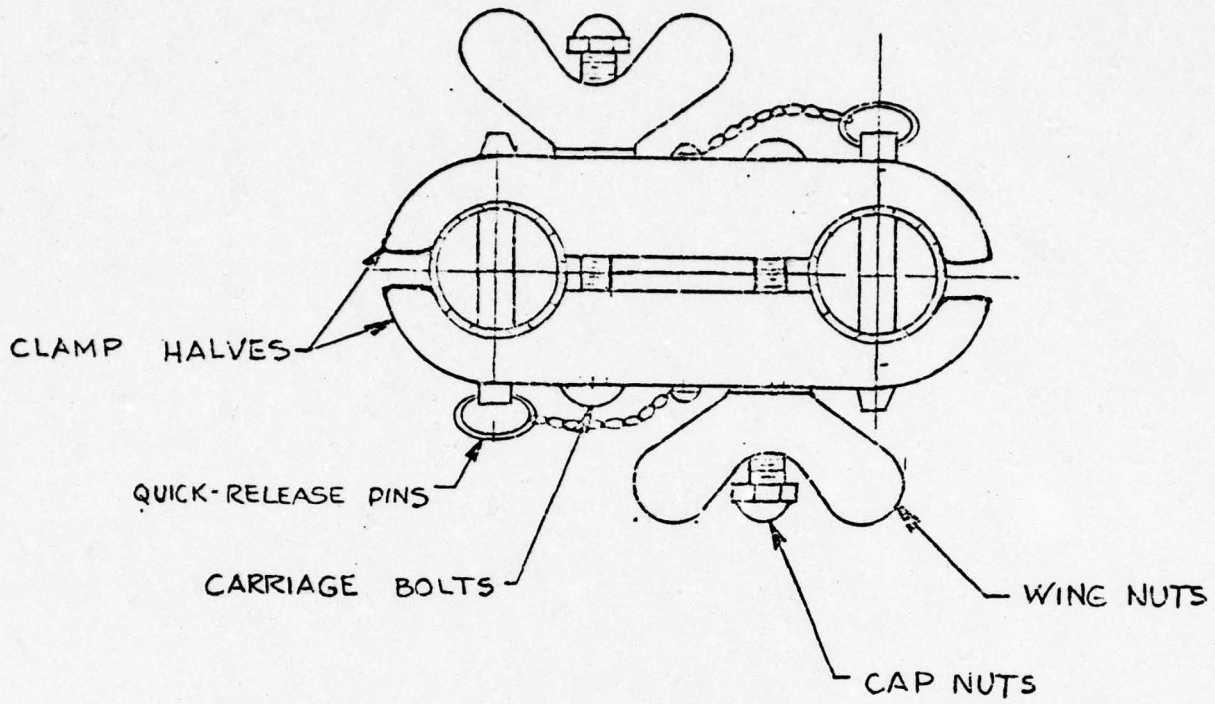

DIELECTRIC BOOM CLAMP
FIGURE 2-12

SEE SEPARATE
DRAWING PACKAGE
DRAWING NO. 72-11006
FIGURE 2-13

SEE SEPARATE
DRAWING PACKAGE
DRAWING NO. 72-11004
FIGURE 2-14

SEE SEPARATE
DRAWING PACKAGE
DRAWING NO. 72-11003
FIGURE 2-15

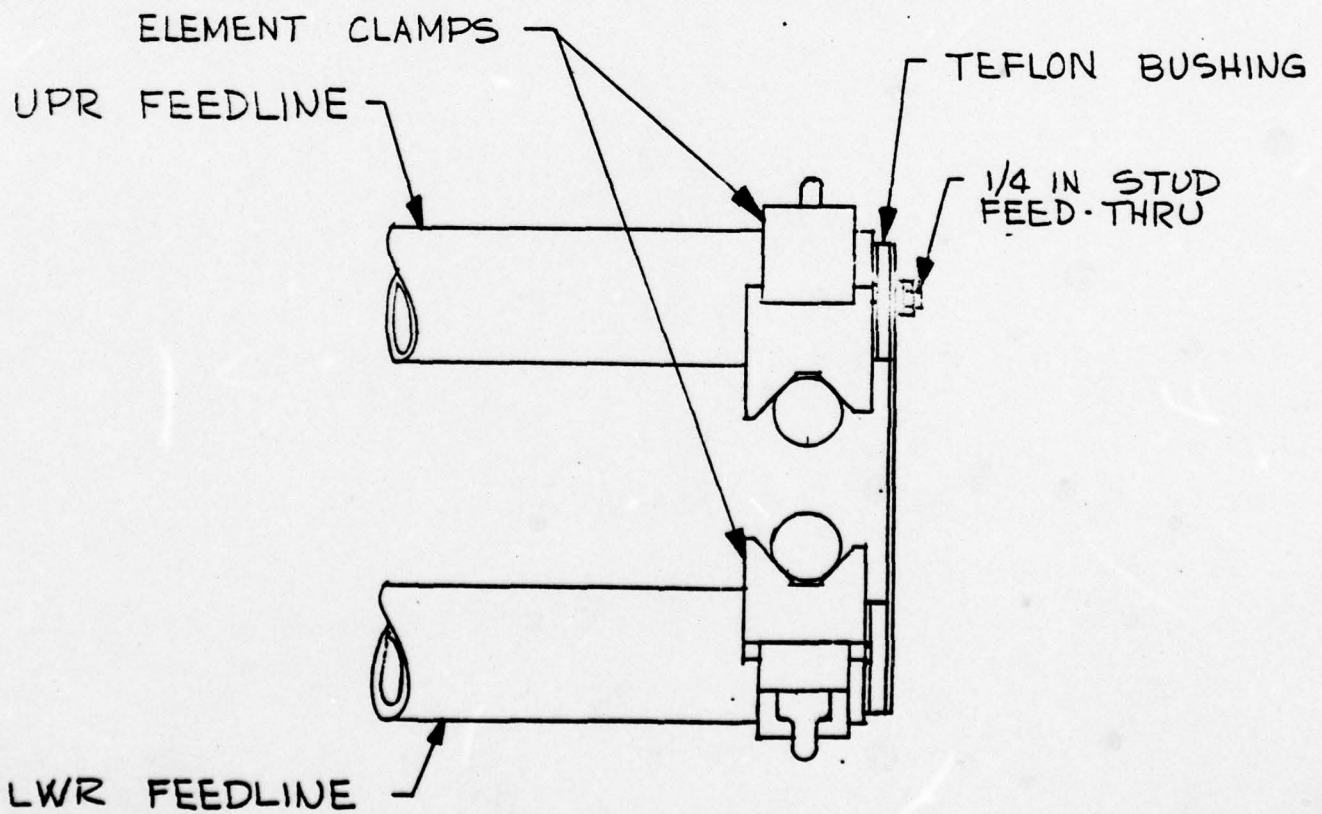
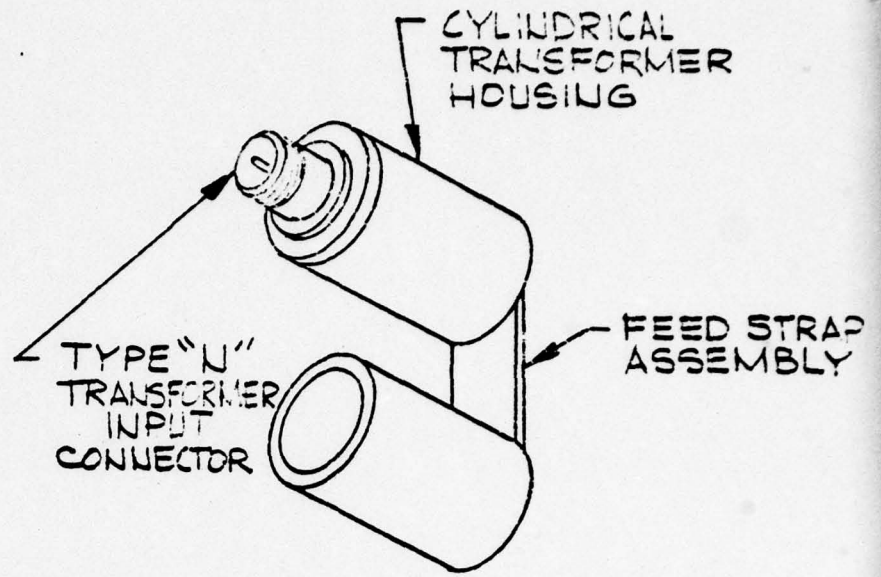

FEEDLINE
 FIGURE 216

area, the inside of the antenna feedlines are nickel plated per MIL-C-26074. The antenna feed strap is 1/16 inch thick by 1 inch wide with 5/16 diameter hole on one end and a welded 1 inch diameter x 1.5 inches long tube on the other end and is permanently secured to the 1/4 inch feed thru stud. The assembled feedpoint bracket and the transformer form into two parallel cylinders with a flat strap connecting them. The cylindrical transformer has a type N connector on the opposite side of the feed thru stud. To connect the feedpoint, the antenna transmission line is fed through the upper antenna feedline (when antenna is in the horizontally polarized position) and connected to the type N connector on the transformer. The antenna element (14) is unlocked and the feed strap and transformers are pressed into the feedlines and the element is reclamped. The feedpoint can easily be connected or disconnected by the unclamping of the front element. During storage, the feed assembly is clamped in position.

2.2.6 Mounting Bracket

The antenna mounting bracket (see Figures 2-17, 2-18) is the interface between the array boom and supporting mast. The bracket is fabricated of cast aluminum alloy 356T-6. Two cross bores allow the antenna to be mounted for vertical or horizontal polarization. A single captivated screw provides clamping force for the bracket. A .375" diameter

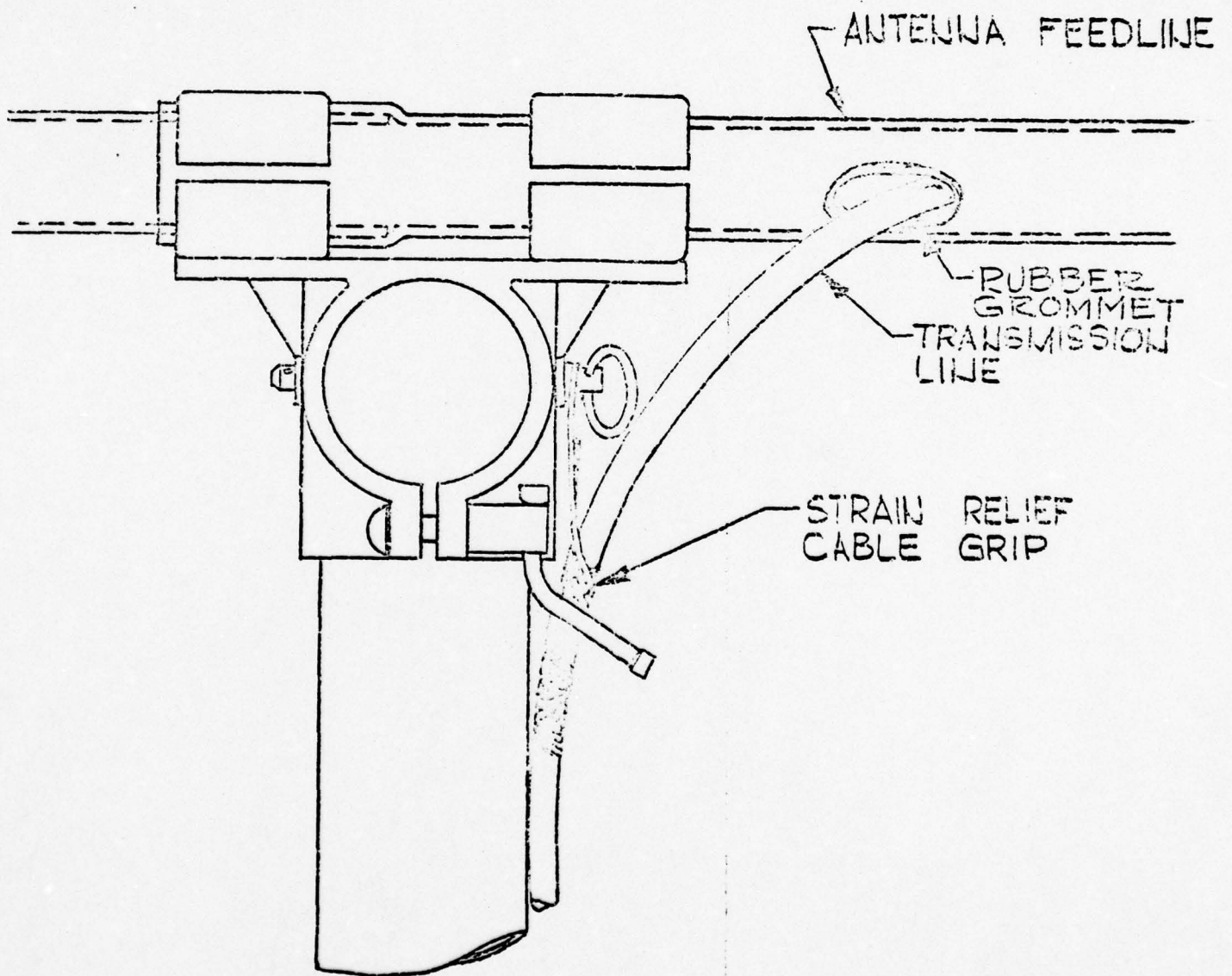

ANTENNA MOUNTING BRACKET
FIGURE 2-17

SEE SEPARATE
DRAWING PACKAGE
DRAWING NO. 72-11005

FIGURE 2-18

captivated quick-release pin is used in conjunction with the screw to provide a strong gall-free connection.

The mounting bracket is permanently attached to the boom spacer clamps of boom section no. 3.

2.2.7 Transmission Line

The 60-foot RG-213/U coaxial transmission line is fed through the antenna mast and supported at the mast cap assembly by a strain relief cable grip. At the mast top, the transmission line is fed through an opening on the upper feedline as shown in Figure 2-17 . The feedline opening is lined with a rubber grommet to prevent cutting of coaxial cable, and is forward of the antenna mounting bracket. The opening is located 45 degrees off the mast vertical center line and on the pivot side of the mast so that in either the vertical or horizontal antenna position, the opening is always 45° down from the horizontal. This will minimize collection of water inside the feedline. The transmission line is fed through the feedline to the antenna feedpoint and connected to the transformer type "N" input connector.

2.2.8 Antenna Weight

The weight of the prototype antenna array is analyzed in detail in Appendix B. The weight analysis shows the antenna array weighs less than the 50 pound maximum. In reviewing the antenna design, and the weight of all the component parts, one can see that a compromise is required

between antenna ruggedness and antenna weight. One area where ruggedness can be sacrificed for weight is the antenna elements. The elements, however, are the one component part which will receive the most abuse during transit and erection. For these reasons, all the antenna elements were designed for stresses greater than the environmental wind loadings. This approach has resulted in an antenna design which is sufficiently rugged and yet is under the maximum allowable weight limit.

2.2.9 Packaging

The prototype antenna configuration disassembles into four major boom assemblies plus the coaxial cable assembly. This minimum number of parts facilitates the packaging of the antenna system. In disassembling the antenna for packaging, the coaxial cable is disconnected and pulled out of the feedline. The antenna array can now be disassembled into the four (4) antenna sections (see Figures 2-7, 2-8, 2-9, and 2-10) by simply unclamping the feedline spacer/boom clamp (see Figure 2-12). Each boom assembly can then be prepared for storage by telescoping and folding all elements and clamping them adjacent to the boom. Figures 2-19, 2-20, 2-21, and 2-22 illustrate the four (4) boom assemblies in the packaged position. The assemblies, 5-feet long maximum, are all stored in the carrying case as shown in Figure 2-23. In the package, the antenna is required to withstand both drop and bounce tests. To protect each boom section from

damage, the boom sections are separated by polyethelene foam padded partitions within the nylon duck carrying case. These partitions cushion the metal components and protect them from damage. The ends of the carrying case are also padded to protect the ends of the antenna sections. Since the antenna sections are 5 feet, the carrying case padding causes the carrying case dimensions to exceed the 5 feet allowable for the case. This is the area discussed in the Introduction which needs clarification. ESI requests that the packaged antenna length dimensions be changed to 5'-1 1/2" maximum.

2.2.10 Carrying Case

The antenna carrying case fabricated of nylon cloth per MIL-C-43375, is a roll type designed with polyethelene foam paddings and straps to firmly secure all antenna parts and protect them during normal handling of the packaged antenna (see Figure 2-23). Each of the 4 folded boom sections are separated from each other by foam padded partitions and securely strapped to the carrying bag. The coaxial cable is stored in the same pocket as the boom section containing the antenna mounting bracket. This will give the coax cable additional protection and facilitate storage. The antenna mounting bracket is stored mounted on the antenna boom. The antenna assembly instruction sheet is mounted on the inside flap of the carrying case.

ELEMENT NO. 2 STOWED
ADJACENT TO LWR FEED LINE

ELEMENT NO. 1
STOWED ADJACENT TO LWR
FEED LINE

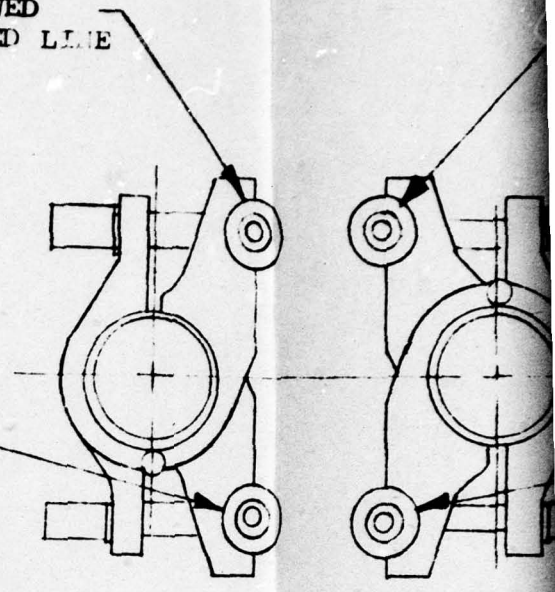

VIEW A-A

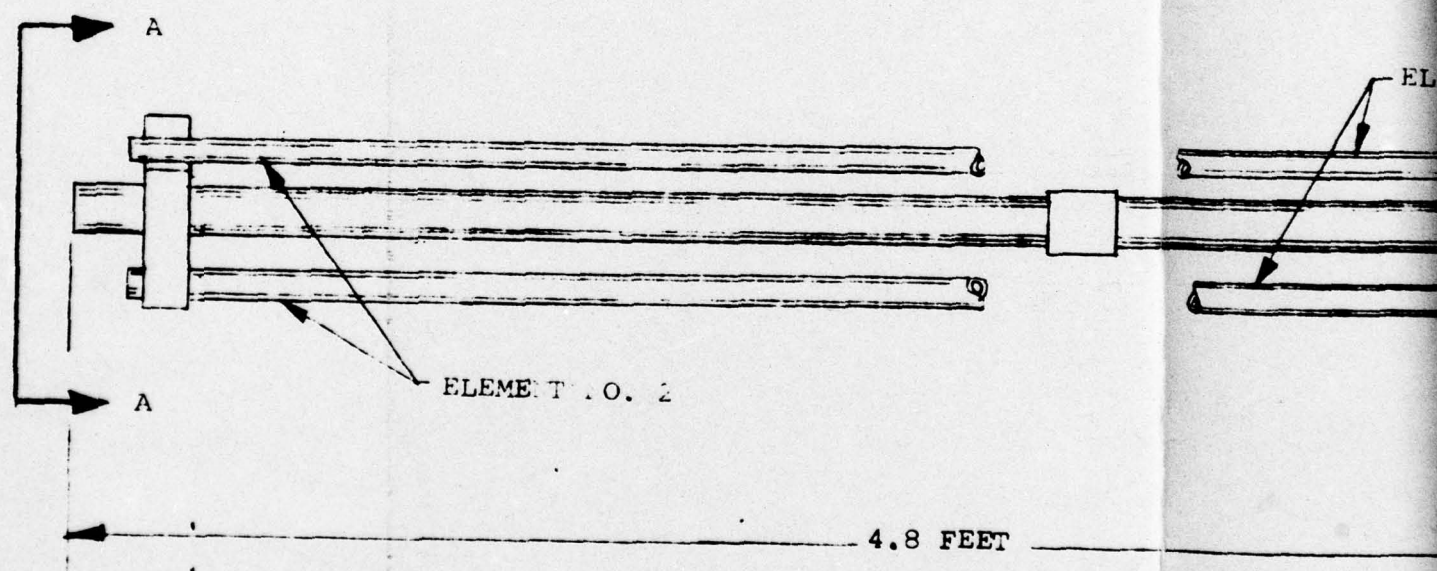

ELEMENT NO. 1 STOWED
ADJACENT TO UPR FEED LINE

ELEMENT NO. 2 STOWED
ADJACENT TO UPR FEED LINE

VIEW A-A

ELEMENT NO. 1

BOOM SECTION NO. 1;
ELEMENTS STOWED

FIGURE 2-19

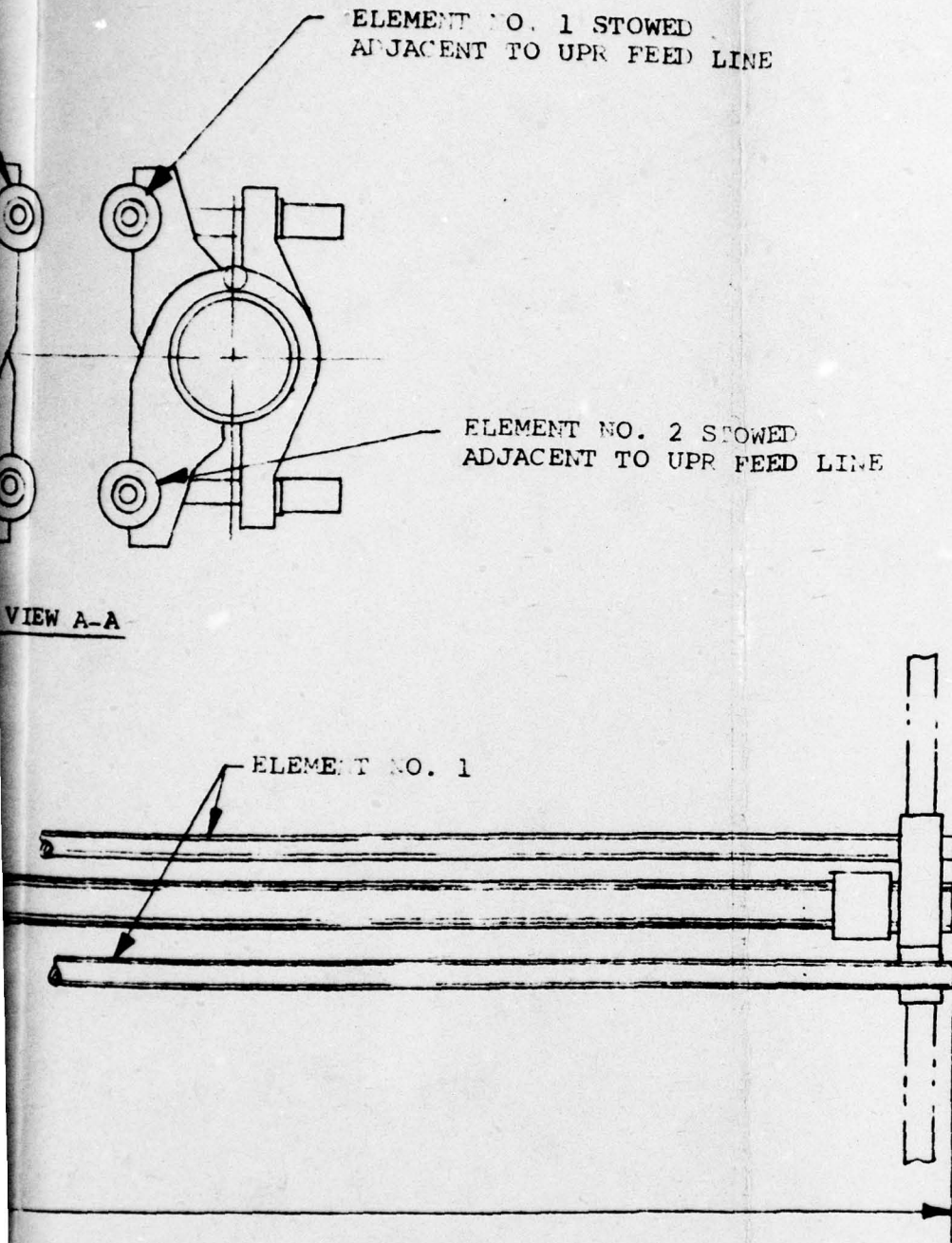

ELEMENT NO. 4 STOWED
ADJACENT TO LWR FEED

ELEMENT NO. 3 STOWED
ADJACENT TO LWR FEED LINE

ELEMENT NO. 5 ROTATED AND
STOWED ADJACENT TO LWR FEED

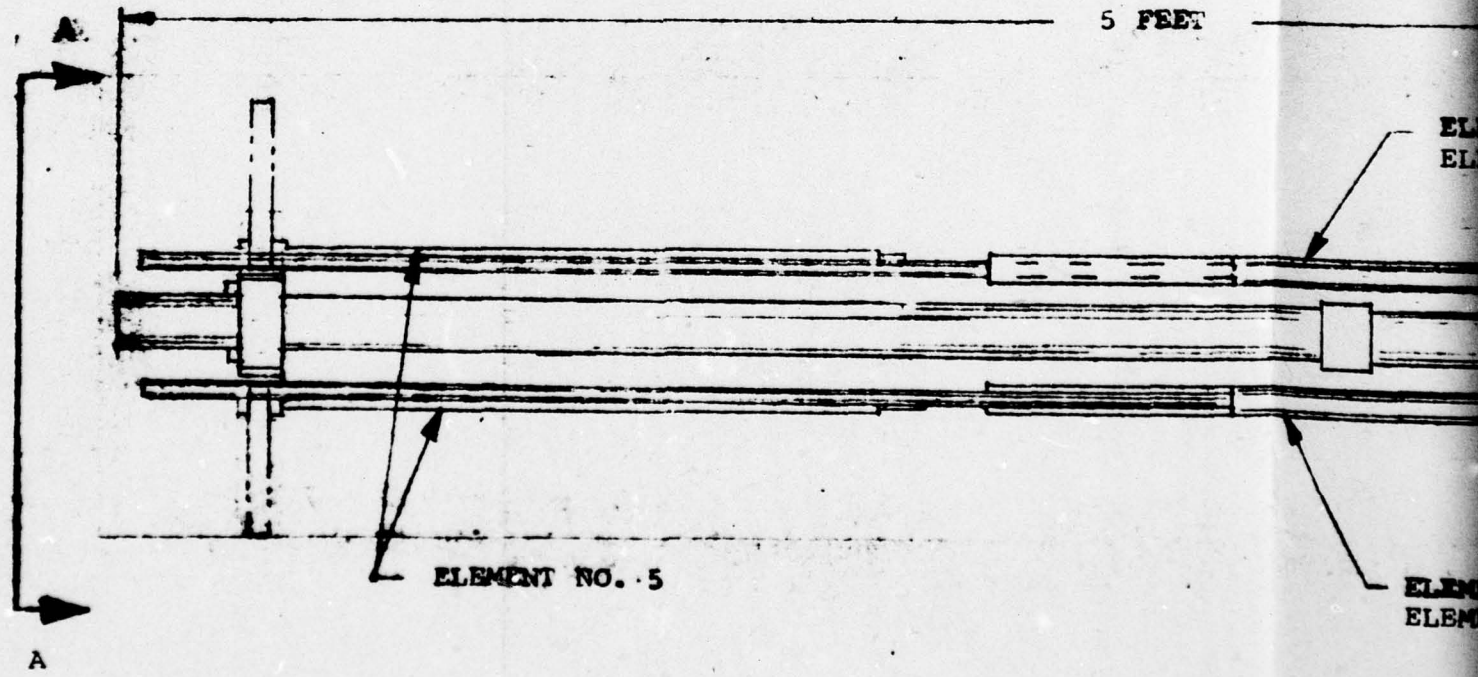

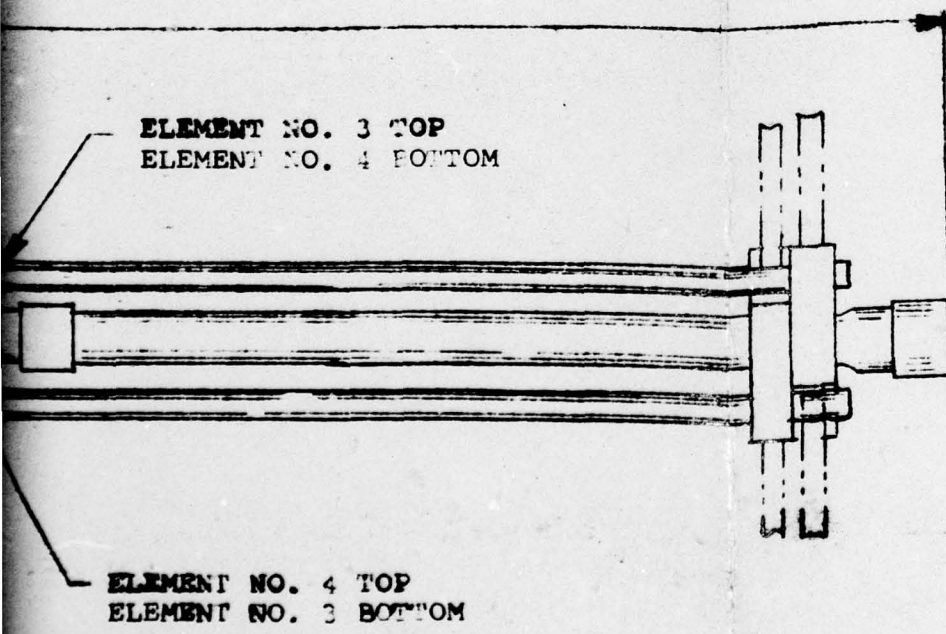
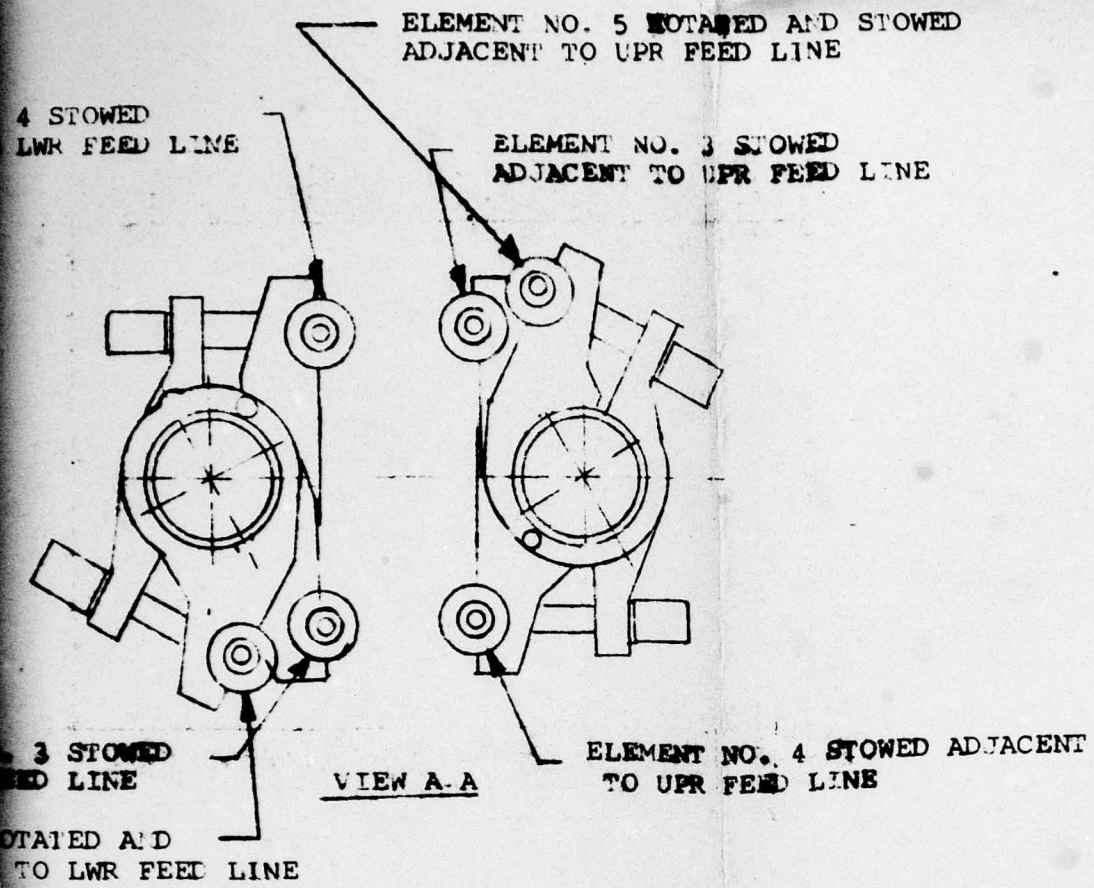

BOOM SECTION NO. 2
ELEMENTS STOWED

FIGURE 2a20

2

ELEMENT NO. 7 STOWED
ADJACENT TO LWR FEED

ELEMENT NO. 6 STOWED
ADJACENT TO LWR FEED LINE

ELEMENT NO. 5 ROTATED AND
STOWED ADJACENT TO LWR

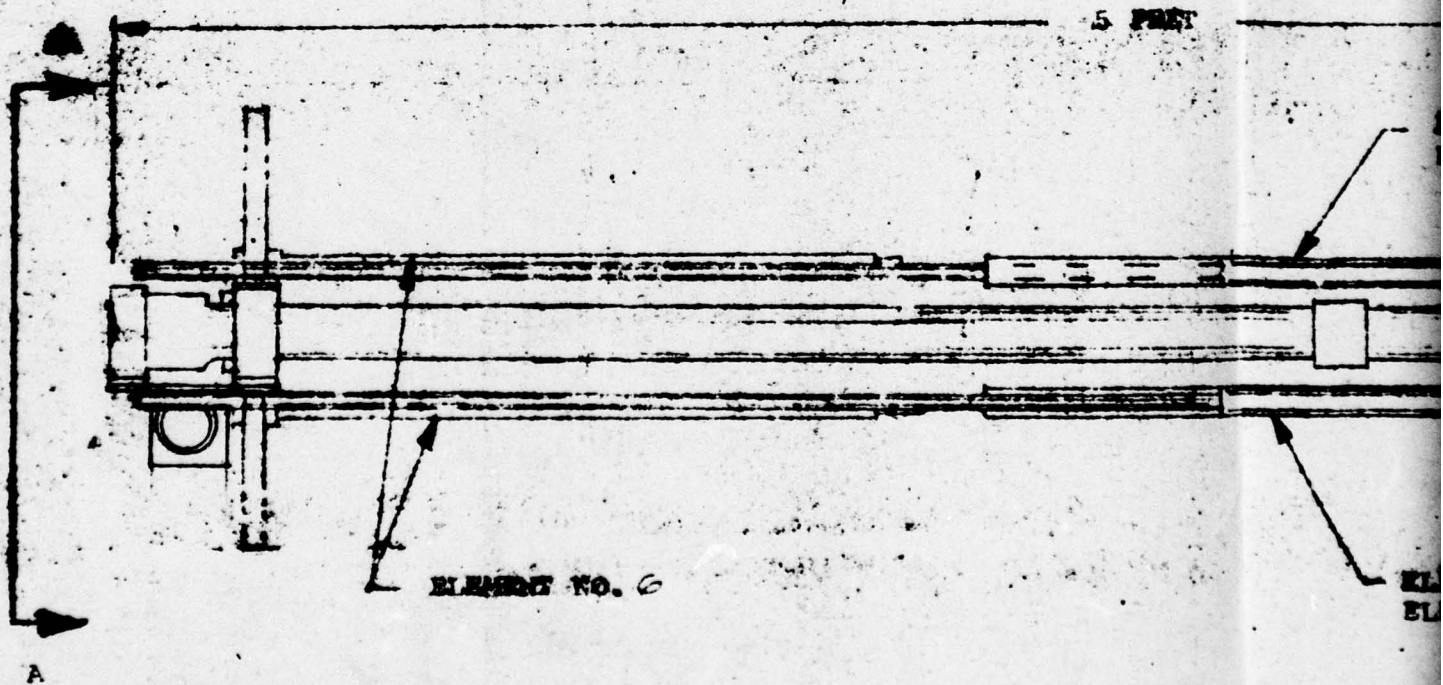

NO. 7 STOWED
TO LWR FEED LINE

ELEMENT NO. 6 ROTATED AND STOWED
ADJACENT TO UPR FEED LINE

ELEMENT NO. 8 STOWED
ADJACENT TO UPR FEED LINE

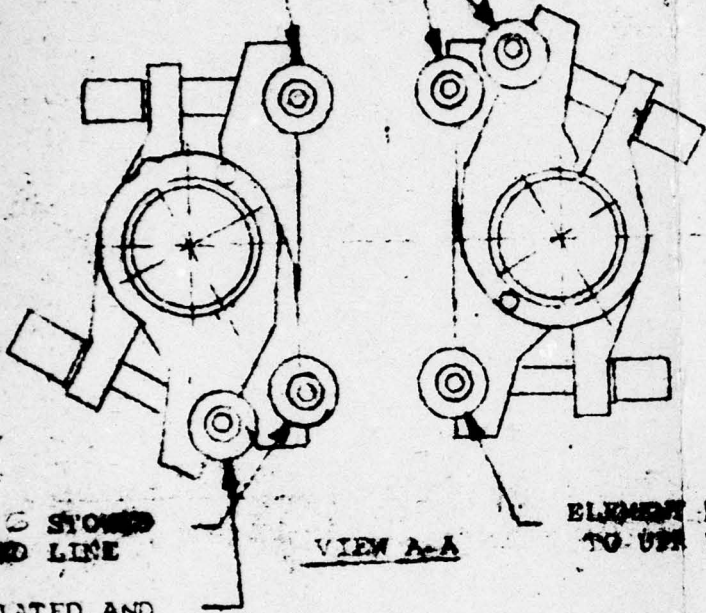

NO. 6 STOWED
FEED LINE

VIEW A-A

ELEMENT NO. 7 STOWED ADJACENT
TO UPR FEED LINE

ROTATED AND
STOWED TO LWR FEED LINE

ELEMENT NO. 8 TOP
ELEMENT NO. 7 BOTTOM

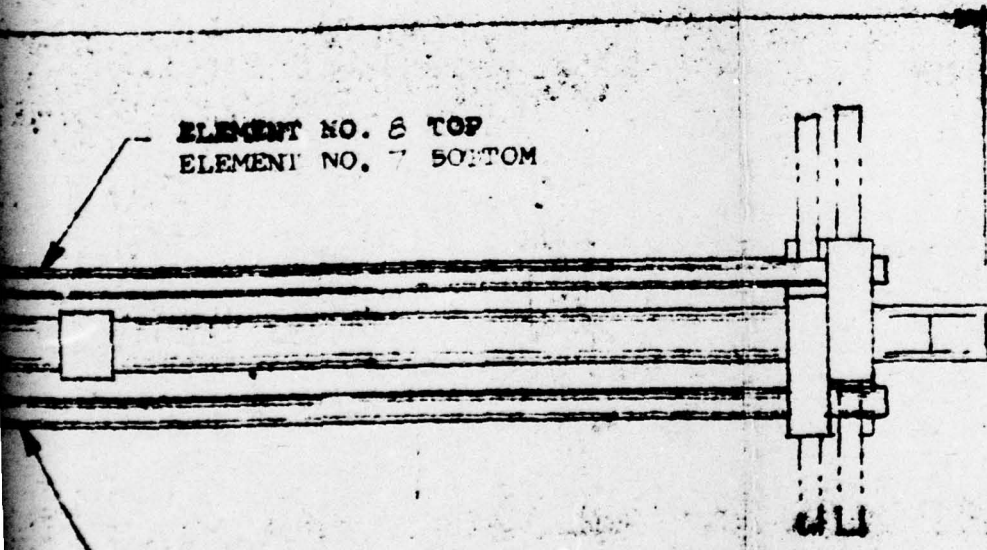

ELEMENT NO. 7 TOP
ELEMENT NO. 8 BOTTOM

BOOM SECTION NO. 3
ELEMENTS STOWED

FIGURE 2421

ELEMENT NO. 13
ROTATED & STOWED
ADJACENT TO LWR
FEED LINE

ELEMENT NO. 14
STOWED ADJACENT TO LWR
FEED LINE

ELEMENT NO. 12 ROTATED &
STOWED ADJACENT TO LWR
FEED LINE

ELEMENT NO.
& STOWED
LWR FEED

ELEMENT NO. 4
STOWED ADJACENT
TO UPR FEED LINE

SECTION A-A

ELEMENT NO. 13
ROTATED & STOWED
ADJACENT TO LWR
FEED LINE

ELEMENT NO. 12
ROTATED & STOWED
ADJACENT TO UPR
FEED LINE

ELEMENT NO. 12

ELEMENT NO. 13 TOP
ELEMENT NO. 14 BOTTOM

A

A

ELEMENT A
ELEMENT

ELEMENT NO. 12 TOP
ELEMENT NO. 14 BOTTOM

ELEMENT NO. 3

5 FEET

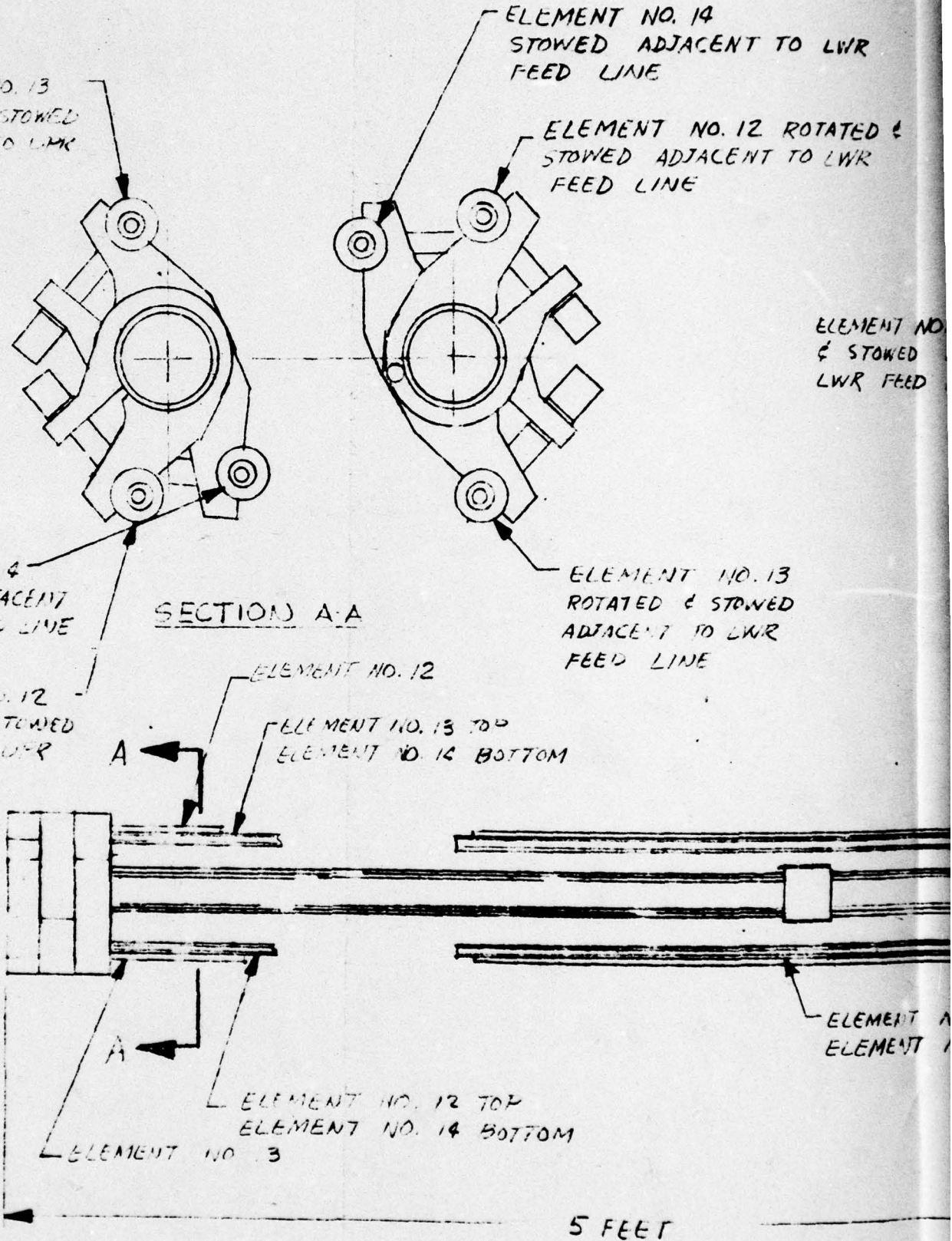

ELEMENT NO. 12 ROTATED & STOWED ADJACENT TO LWR FEED LINE

ELEMENT NO. 9 STOWED ADJACENT TO UPR FEED LINE

ELEMENT NO. 11 ROTATED & STOWED ADJACENT TO UPR FEED LINE

ELEMENT NO. 11 ROTATED & STOWED ADJACENT TO FEED LINE

ELEMENT NO. 9 STOWED ADJACENT TO LWR FEED LINE

ELEMENT NO. 10 STOWED ADJACENT TO UPR FEED LINE

SECTION B.B

ELEMENT NO. 9 UPR
ELEMENT NO. 10 LWR

ELEMENT NO. 11

ELEMENT NO. 10 UPR
ELEMENT NO. 9 LWR

ELEMENT NO. 11

BOOM SECTION NO. 4, ELEMENTS STOWED

FIGURE 2-22

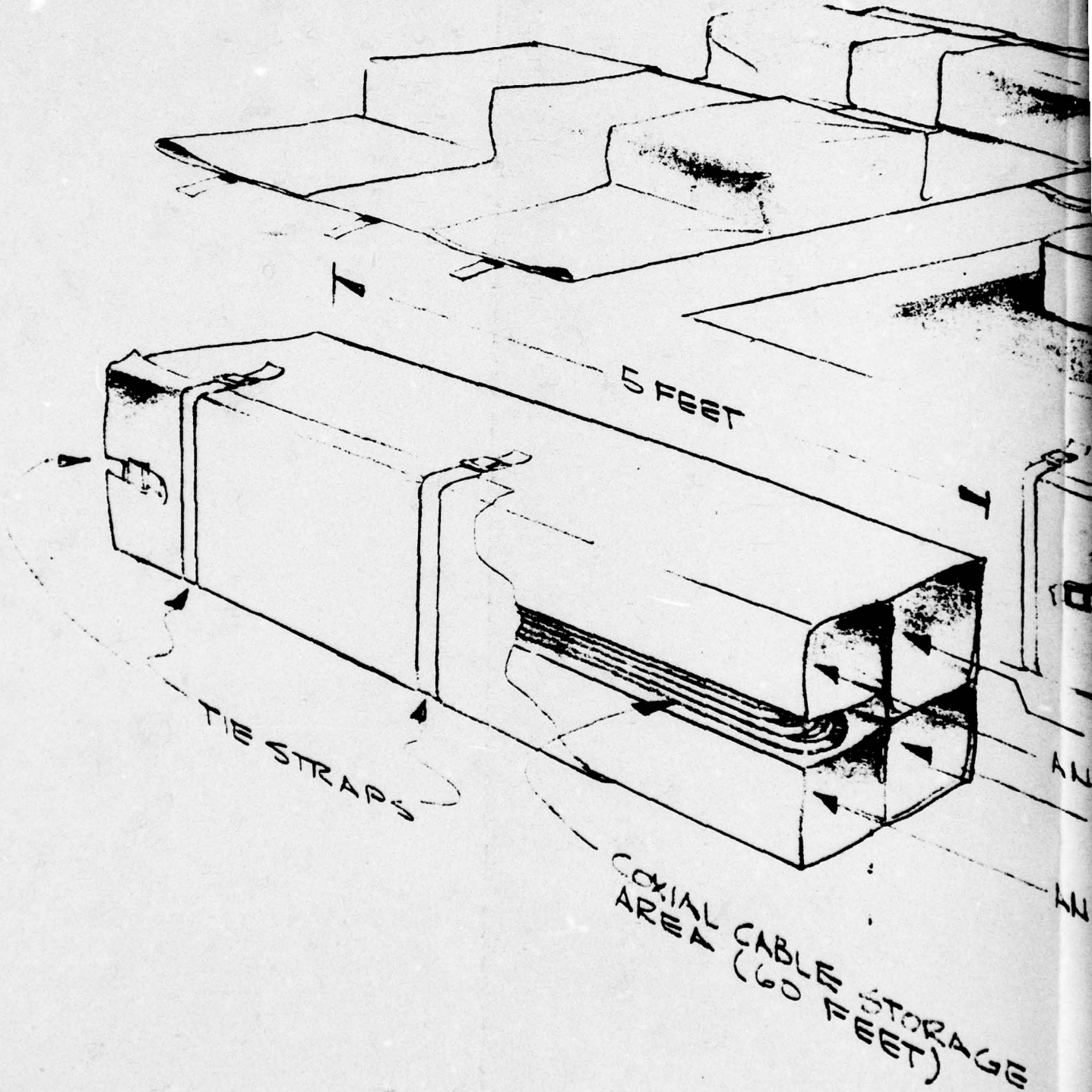

5 FEET

TIE STRAPS

COAXIAL CABLE STORAGE
AREA (60 FEET)

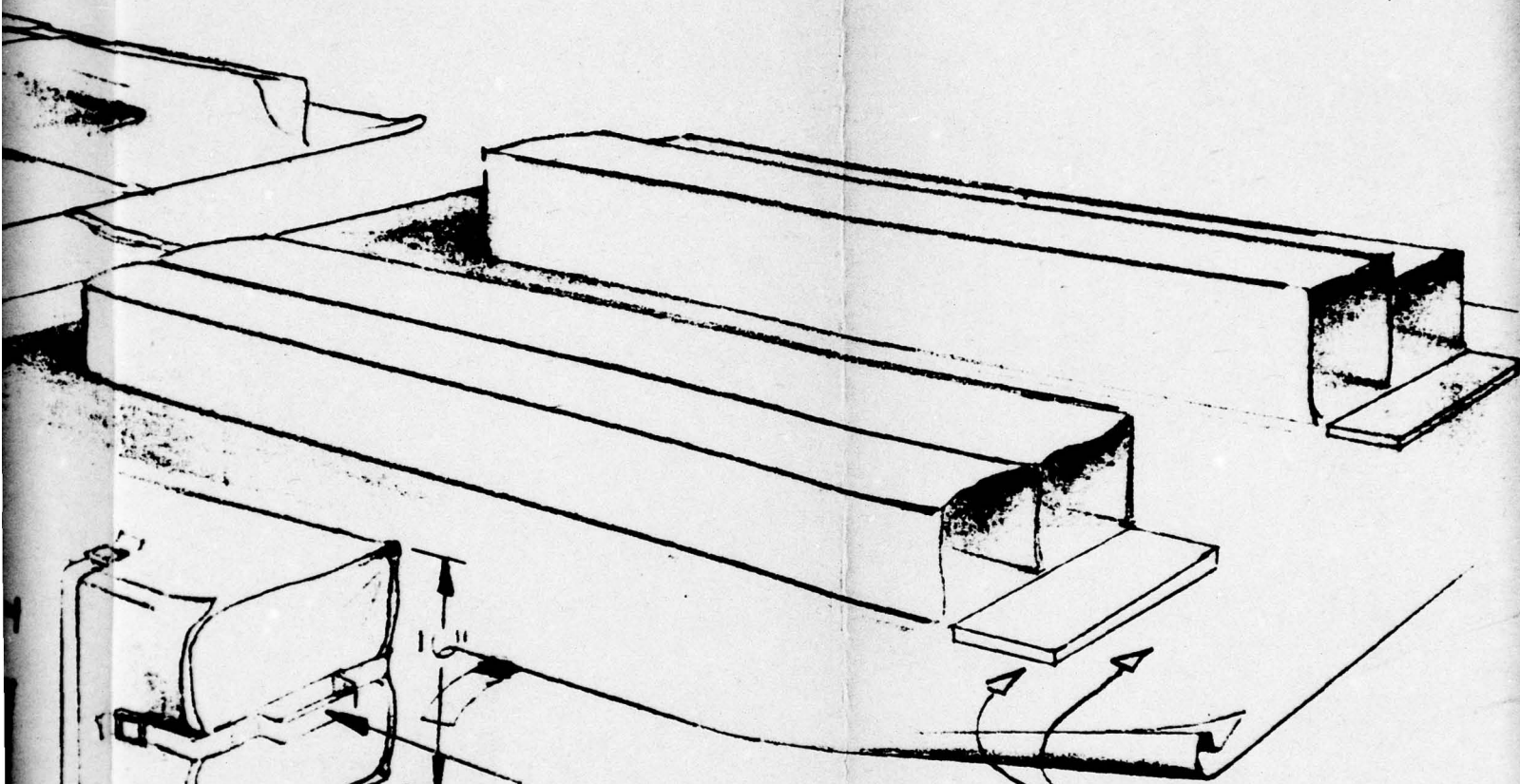

POLYETHYLENE
FOAM PADDING

CARRIAGE HANDLE AND
TIE STRAP (TOP OF END)

- ANTENNA SECTION NO. 3
- ANTENNA SECTION NO. 4
- ANTENNA SECTION NO. 1
- ANTENNA SECTION NO. 2

FIGURE 2-23

2.2.11 Construction

2.2.11.1 Interchangeability

Provisions for interchangeability will be in accordance with Requirement 7 of MIL-STD-454. Interchangeable items will be as defined in MIL-STD-100 and will possess both mechanical and electrical compatability to permit their installation as interchangeable assemblies, subassemblies, and parts without regard to the manufacturer or supplier.

2.2.11.2 Parts, Materials and Processes

The selection, application and use of materials, parts, and processes used in the design of the antenna system will be in accordance with SCL-6200D. Consistent with other requirements, materials chosen shall be inherently fungus proof, insect proof, flame-resistant, and not adversely affected by moisture and temperature.

APPENDIX A

DIRECTIVITY CALCULATIONS
FROM RADIATION PATTERNS

DIRECTIVITY CALCULATIONS FROM RADIATION PATTERNS

The directivity of an antenna is defined as the maximum of the directive gain which is defined by the equation,

$$D(\theta, \phi) = \frac{E^2(\theta, \phi)}{\frac{1}{4\pi} \int_0^{2\pi} \int_0^{\pi} E^2(\theta, \phi) \sin \theta \, d\theta \, d\phi} \quad (1.)$$

where θ and ϕ are spherical coordinates. Usually the antenna is oriented with $\theta = 0^\circ$ straight overhead and $\phi = 90^\circ$ in line with the direction of maximum radiation for an antenna whose maximum radiation lobe is also at $\theta = 90^\circ$. The value of maximum directivity is for some particular value of θ and ϕ ,

$$D_{\max} = \frac{4\pi E^2_{\max}}{\int_0^{2\pi} \int_0^{\pi} E^2(\theta, \phi) \sin \theta \, d\theta \, d\phi} \quad (2.)$$

This equation is usually normalized for use in calculating the relative gain since E_{\max} is some value of the function $E(\theta, \phi)$. Then

$$D_{\max} = \frac{4\pi}{\int_0^{2\pi} \int_0^{\pi} E^2_{\text{norm}}(\theta, \phi) \sin \theta \, d\theta \, d\phi} \quad (3.)$$

One way of approximating the directivity is for the antenna patterns to be measured for a large number of constant θ (ϕ variable) or constant ϕ (θ variable) cuts thus producing a set of patterns each to be integrated continuously (using a planimeter) over one of the variables and the set to be integrated by approximation. That is,

$$\int_0^{2\pi} \int_0^{\pi} E^2(\theta, \phi) \sin \theta \, d\theta \, d\phi \approx \sum_i \int_0^{\pi} E^2(\theta, \phi_i) \sin \theta \, d\theta \, \Delta\phi_i \quad (4.)$$

$$\text{or, } \doteq \sum_i \int_0^{2\pi} E^2(\theta_i, \phi) d\phi \sin \theta_i \Delta \theta_i \quad (5.)$$

This method is usually used for patterns of aircraft antennas where the antenna and aircraft are both modeled and measured together. When $E^2(\theta, \phi)$ is equal to one, for all θ and ϕ , then the maximum value of

$$\int_0^\pi E^2(\theta, \phi_i) \sin \theta d\theta = 2, \text{ for all } \phi_i,$$

and

$$\sum_i 2 \Delta \theta_i = 2 (\Delta \theta_1 + \Delta \theta_2 + \dots + \Delta \theta_N) \quad (6.)$$

$$\text{where } \Delta \theta_i = \frac{2\pi}{N}.$$

Then..... $D_{\max} = \frac{4\pi}{2 \cdot 2\pi} = 1$ which is the correct answer for an isotropic radiator.

Very often the function $E(\theta, \phi)$ can be represented by,

$$E(\theta, \phi) \doteq E_{\max} f_1(\theta) f_2(\phi), \quad (7.)$$

where $f_1(\theta)$ and $f_2(\phi)$ are general functions that describe the principle plane patterns and the product describes the pattern for all values of θ and ϕ . This approximation applies to smooth patterns with low or non-existent sidelobes off the principle planes. Then the integral becomes,

$$\begin{aligned} &\doteq E_{\max}^2 \int_0^{2\pi} \int_0^\pi f_1^2(\theta) f_2^2(\phi) \sin \theta d\theta d\phi \\ &= E_{\max}^2 \int_0^{2\pi} f_2^2(\phi) d\phi \int_0^\pi f_1^2(\theta) \sin \theta d\theta \end{aligned}$$

$$= E_{\max}^2 \cdot \left[\text{integral of principle plane pattern for } \vartheta \text{ variable, } \theta = 90^\circ \right] \cdot \left[\text{integral of principle plane pattern for } \theta \text{ variable, } \vartheta = 90^\circ \right]$$

When the patterns are normalized E_{\max} is equal to one and the maximum value of the integral occurs when $f_1(\theta) = f_2(\vartheta) = 1$ for all θ and ϑ . This is an isotropic radiator and once again,

$$D_{\max} = \frac{4\pi}{2\pi \cdot 2} = 1$$

ESI performs the process of integration on the principle plane patterns using a planimeter. The integration can be performed directly on voltage pattern paper (5), or the pattern data is sometimes transferred to specially calibrated paper which automatically performs the $\sin \theta$ multiplication (and the E^2 multiplication for voltage pattern data).

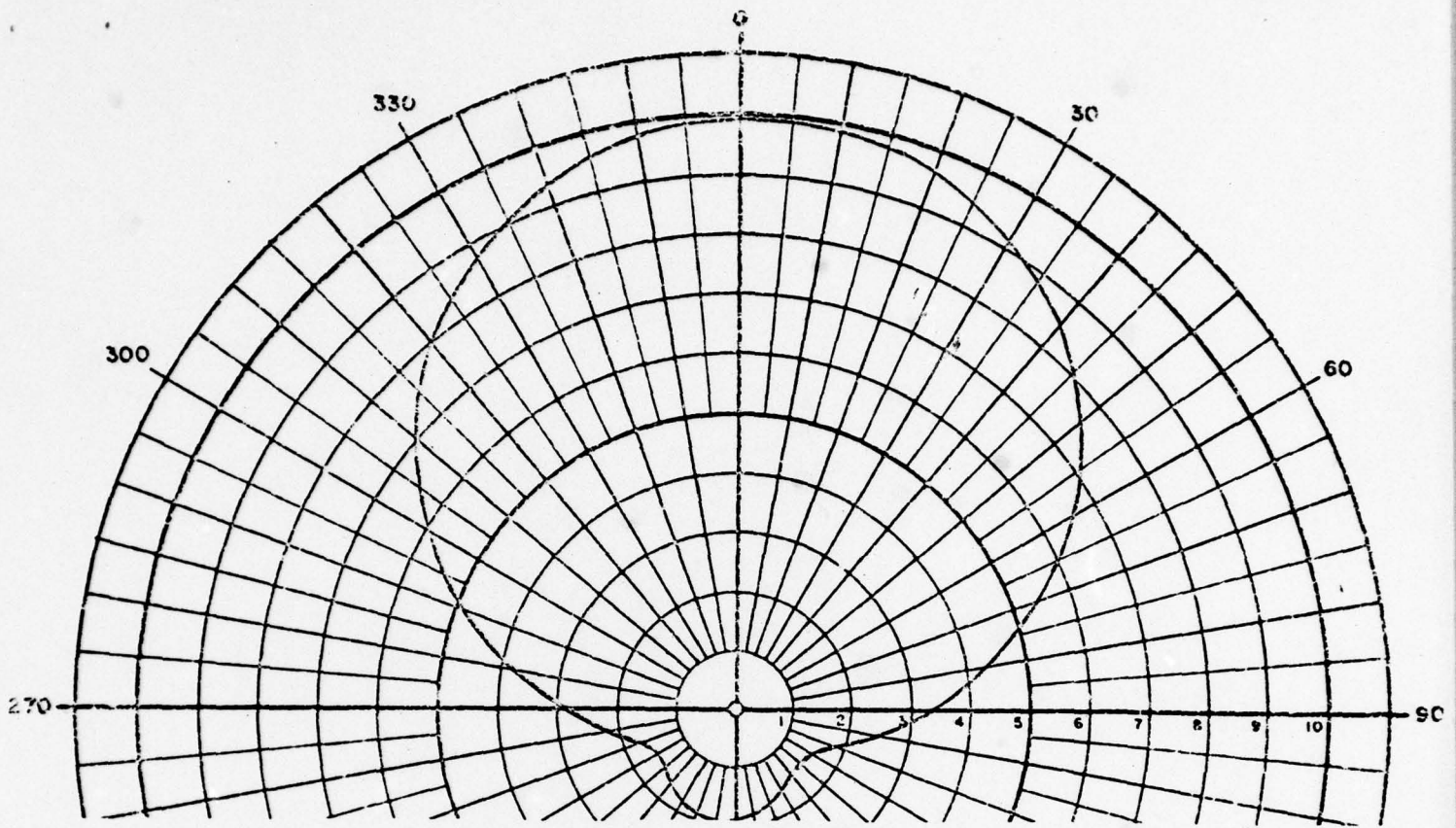

H-Plane

$$\eta = .9$$

$$\alpha = 18.7^\circ$$

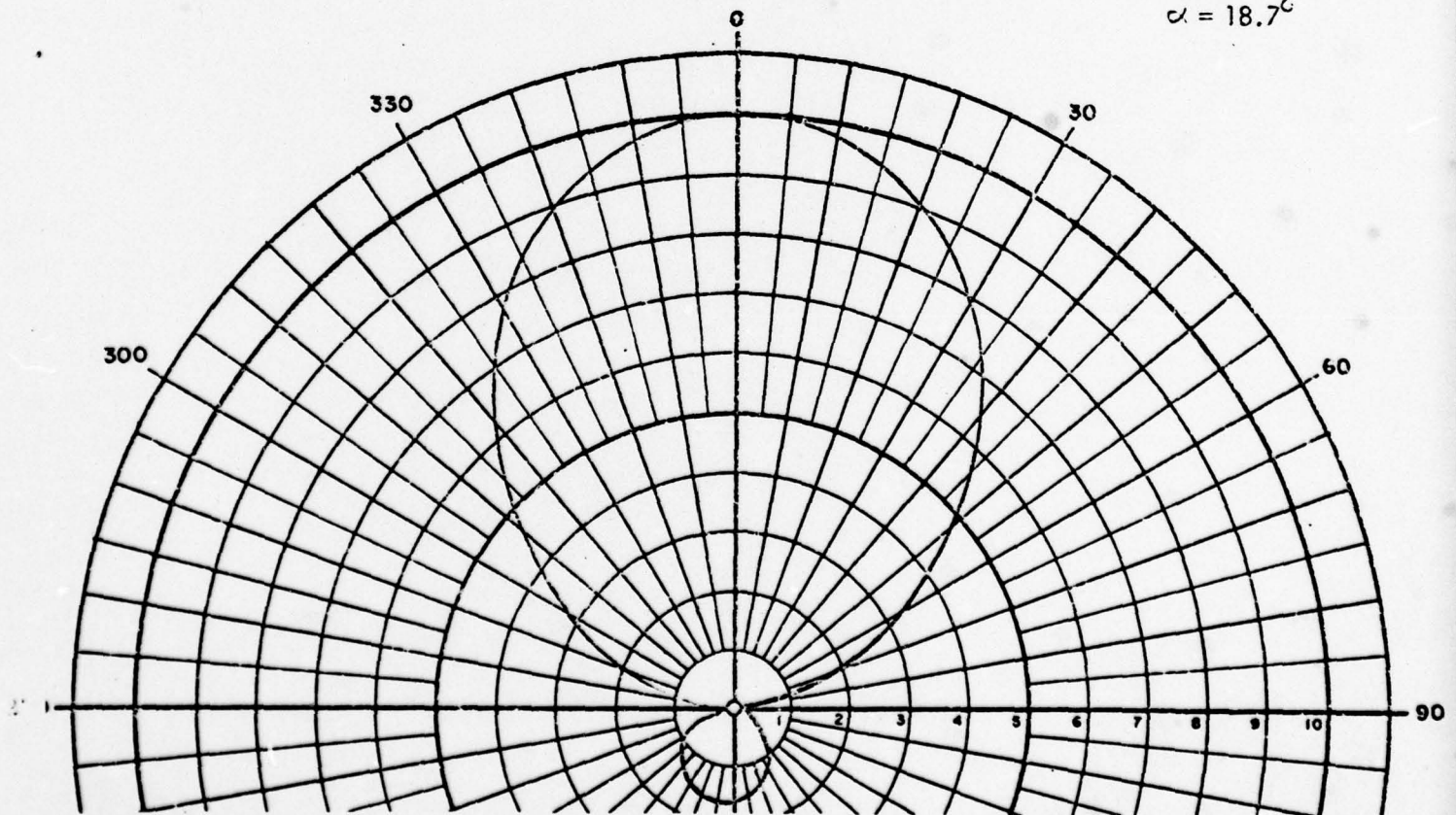

E-Plane

Voltage Patterns, 120 MHz
FIGURE A-1

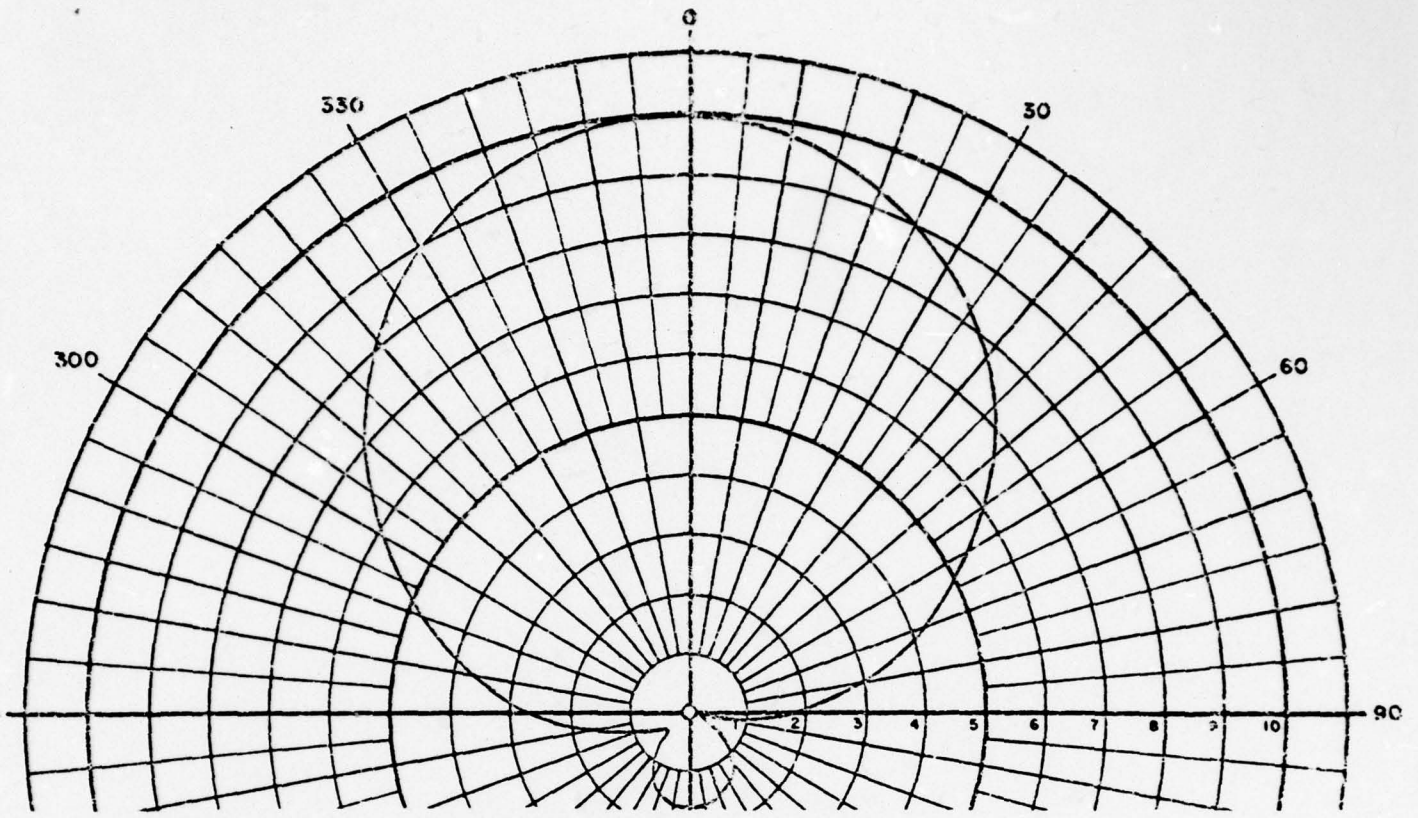

H-Plane

$$\tau = .9$$

$$\alpha = 18.7^\circ$$

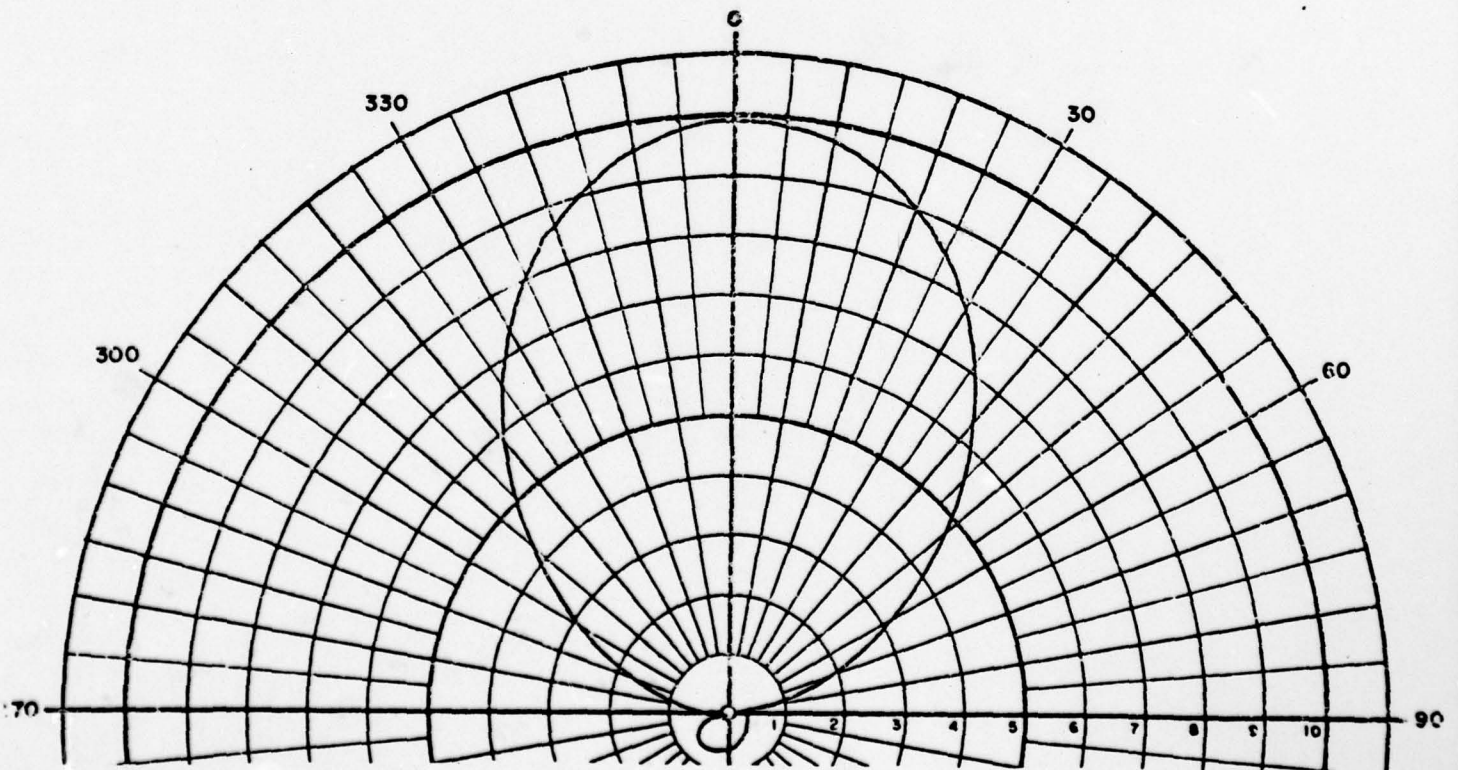

E-Plane

Voltage Patterns, 125 MHz
FIGURE A-2

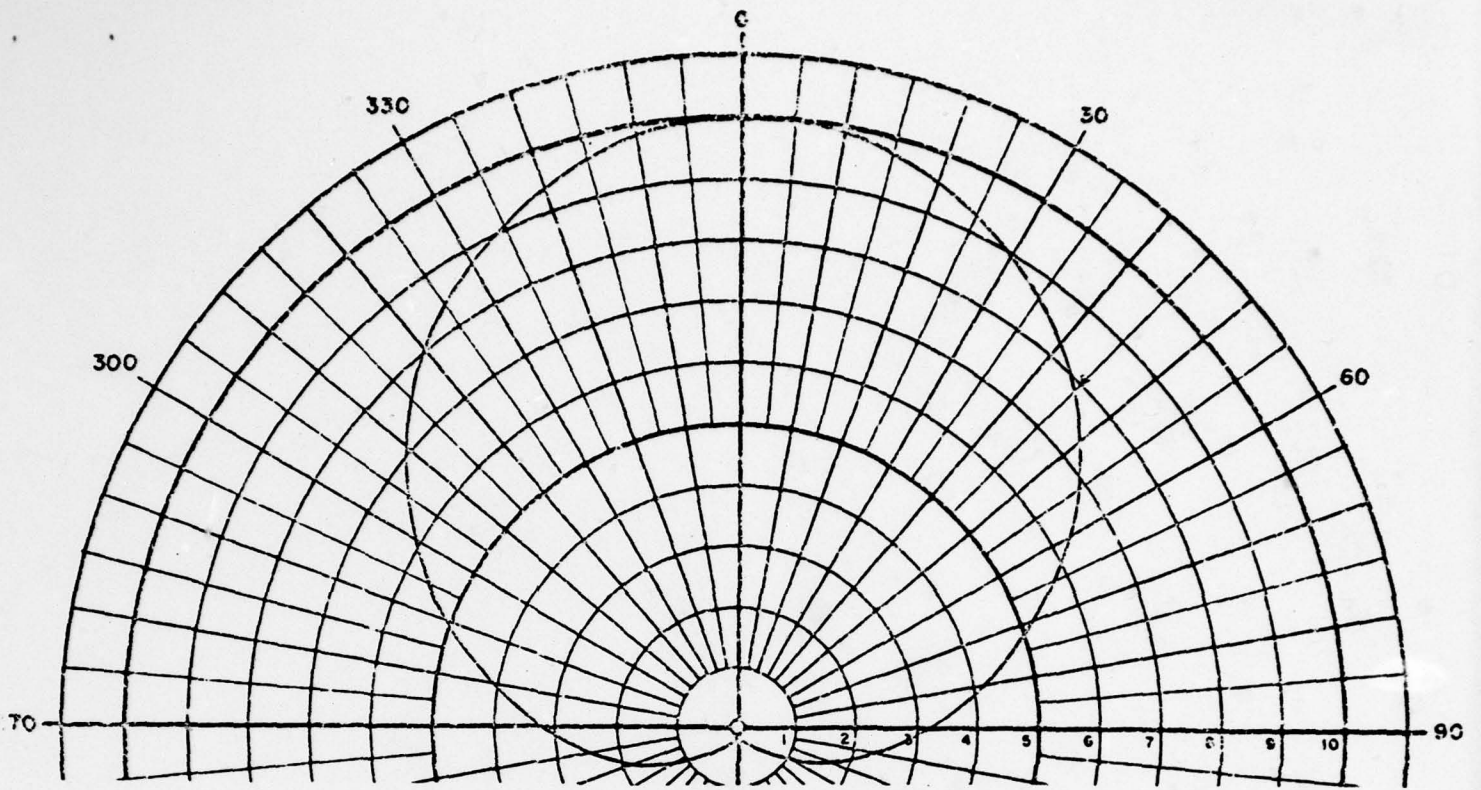

H-Plane

$$\zeta = .9$$

$$\alpha = 18.7^\circ$$

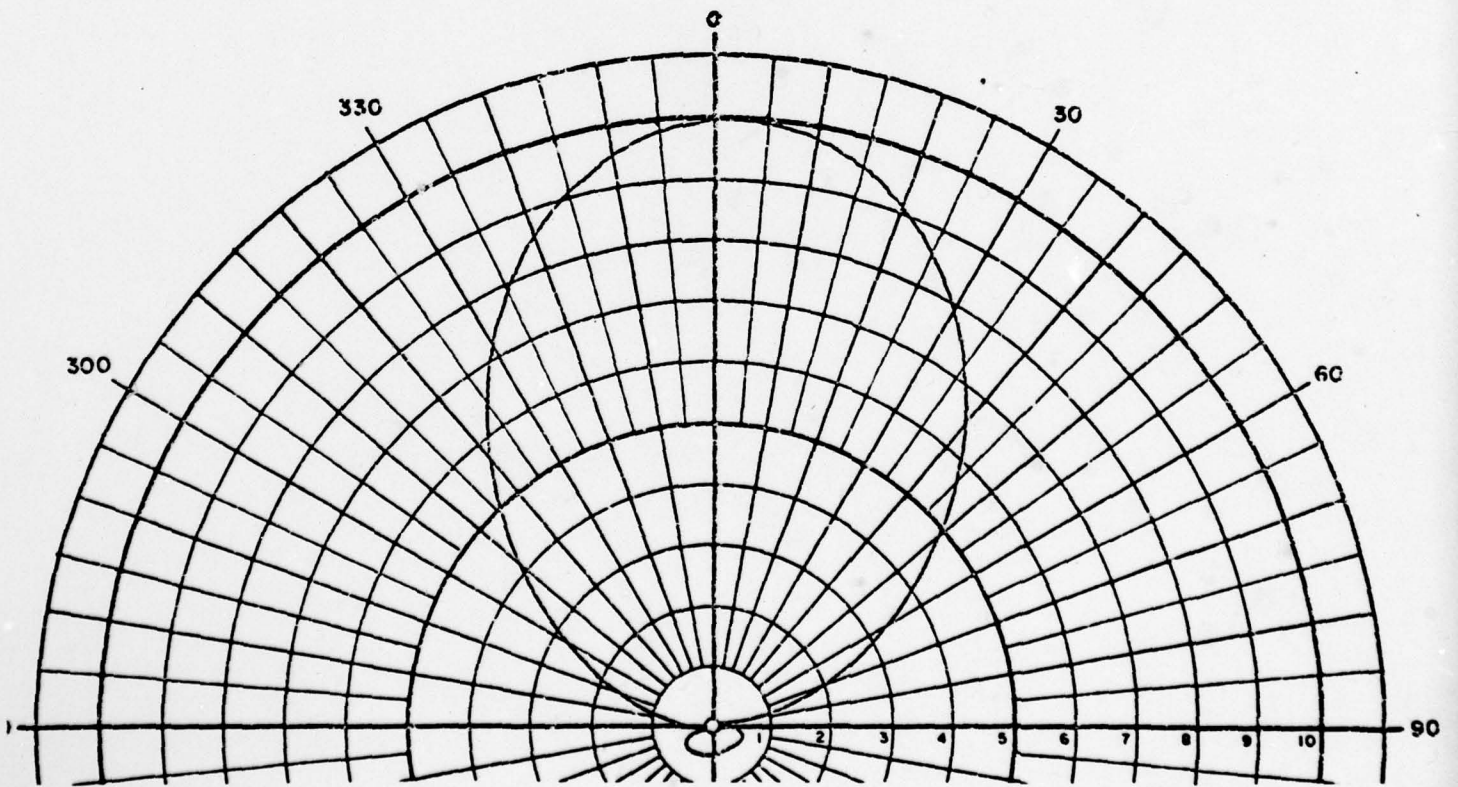

E-Plane

Voltage Patterns, 150 MHz
FIGURE A-3

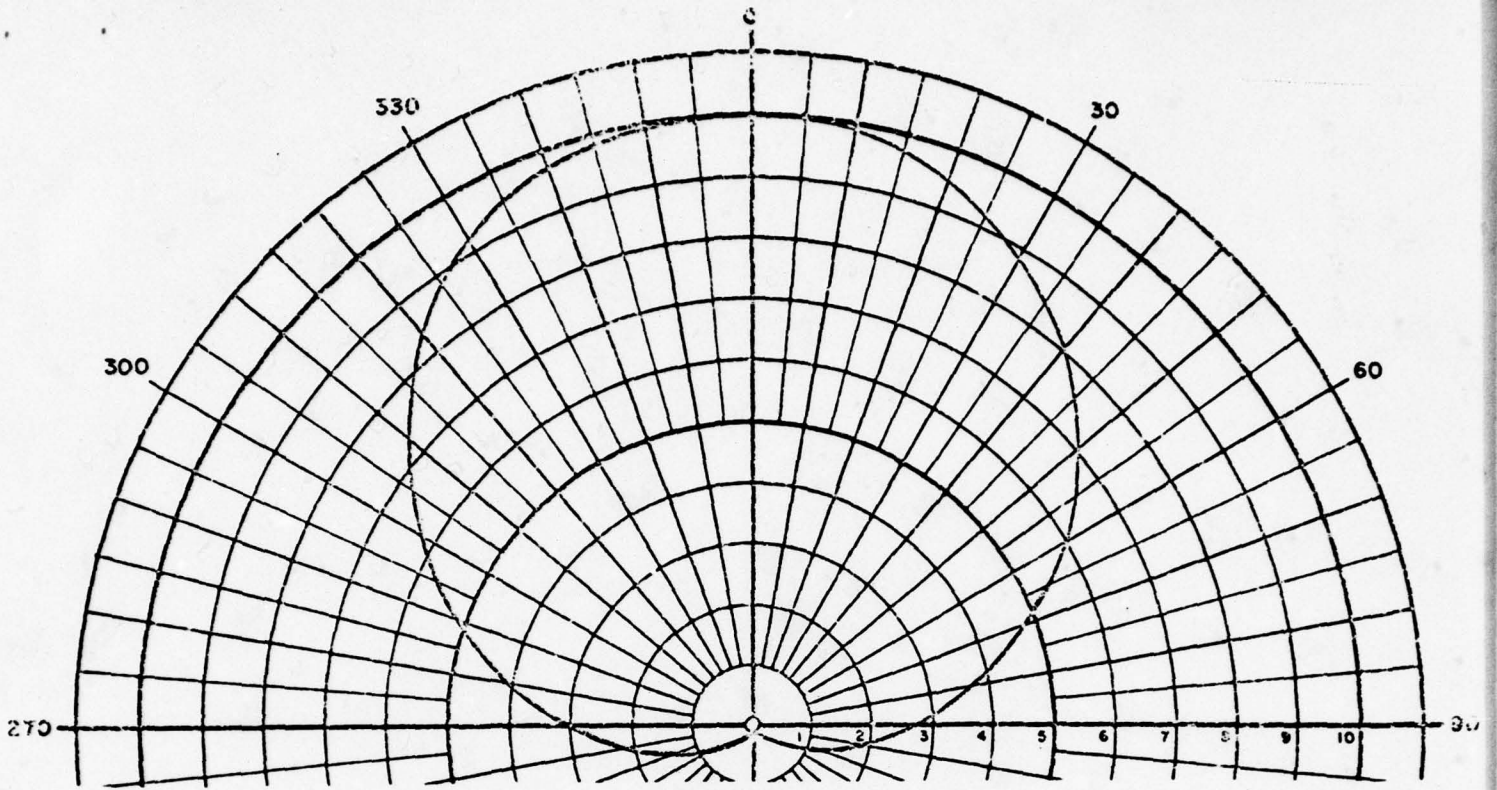

H-Plane

$$\tau = .9$$

$$\alpha = 18.7^\circ$$

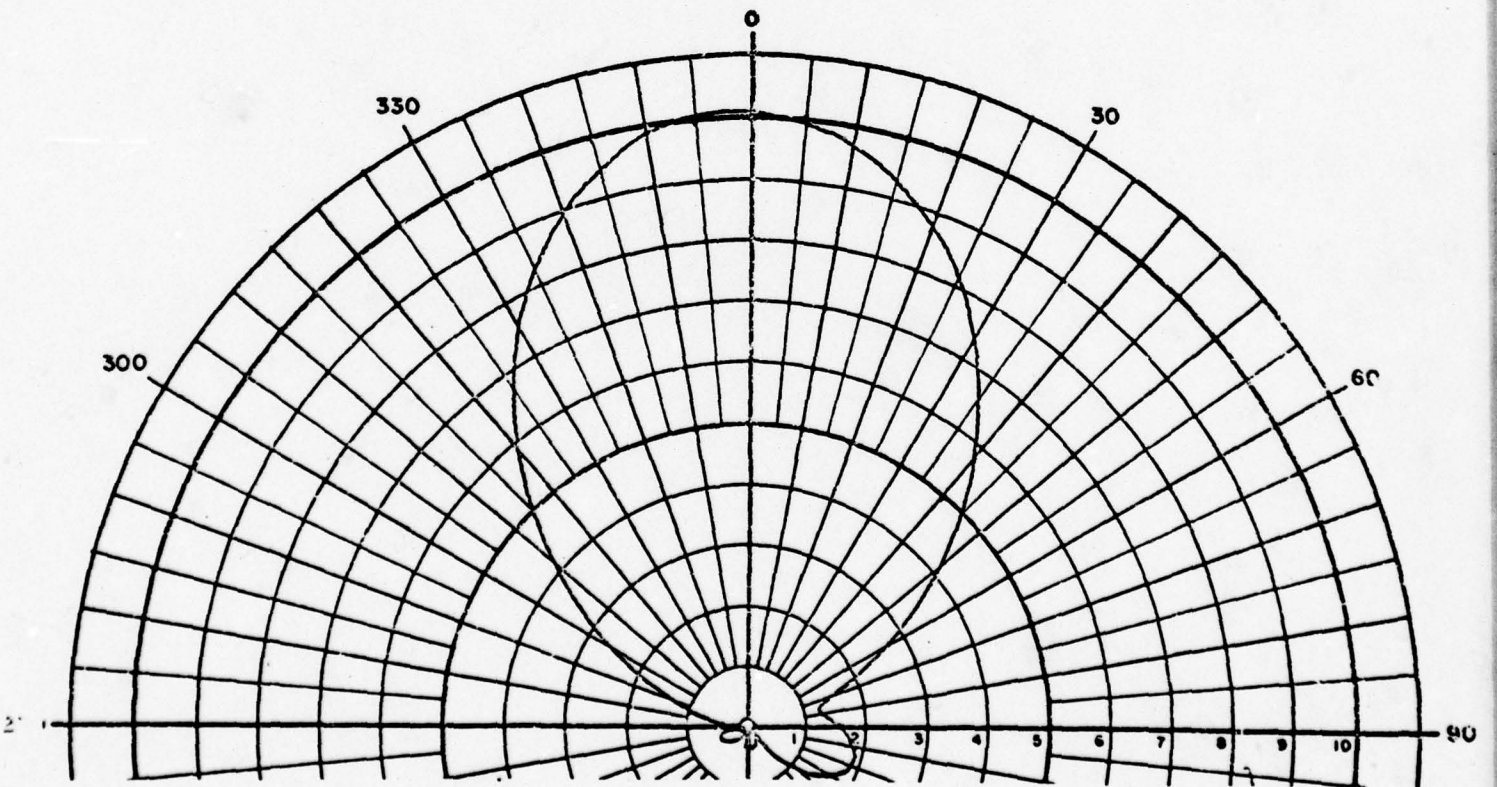

E-Plane

Voltage Patterns, 190 MHz
FIGURE A-4

A-8

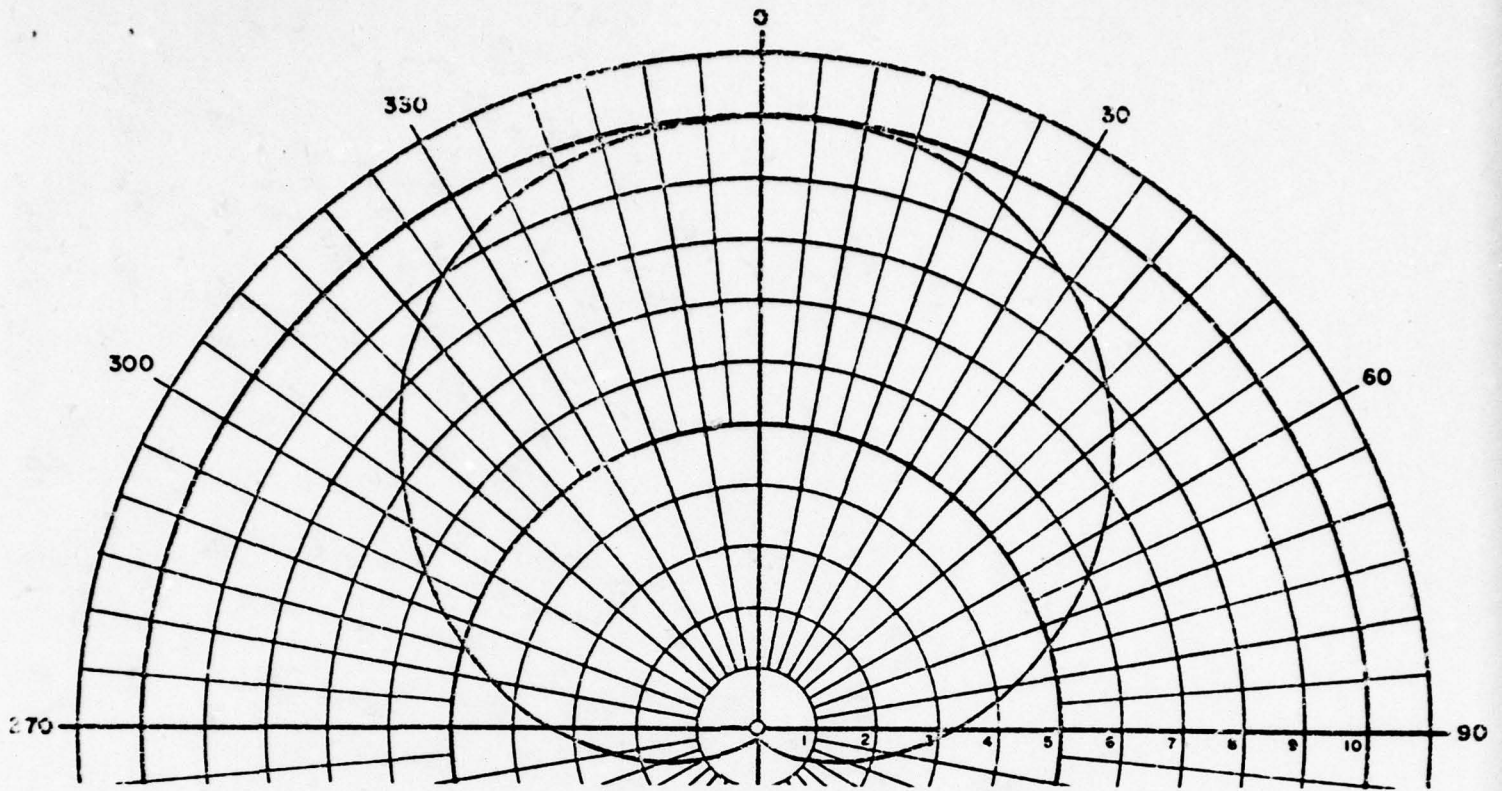

H-Plane

$$\zeta = .9$$

$$\alpha = 18.7^\circ$$

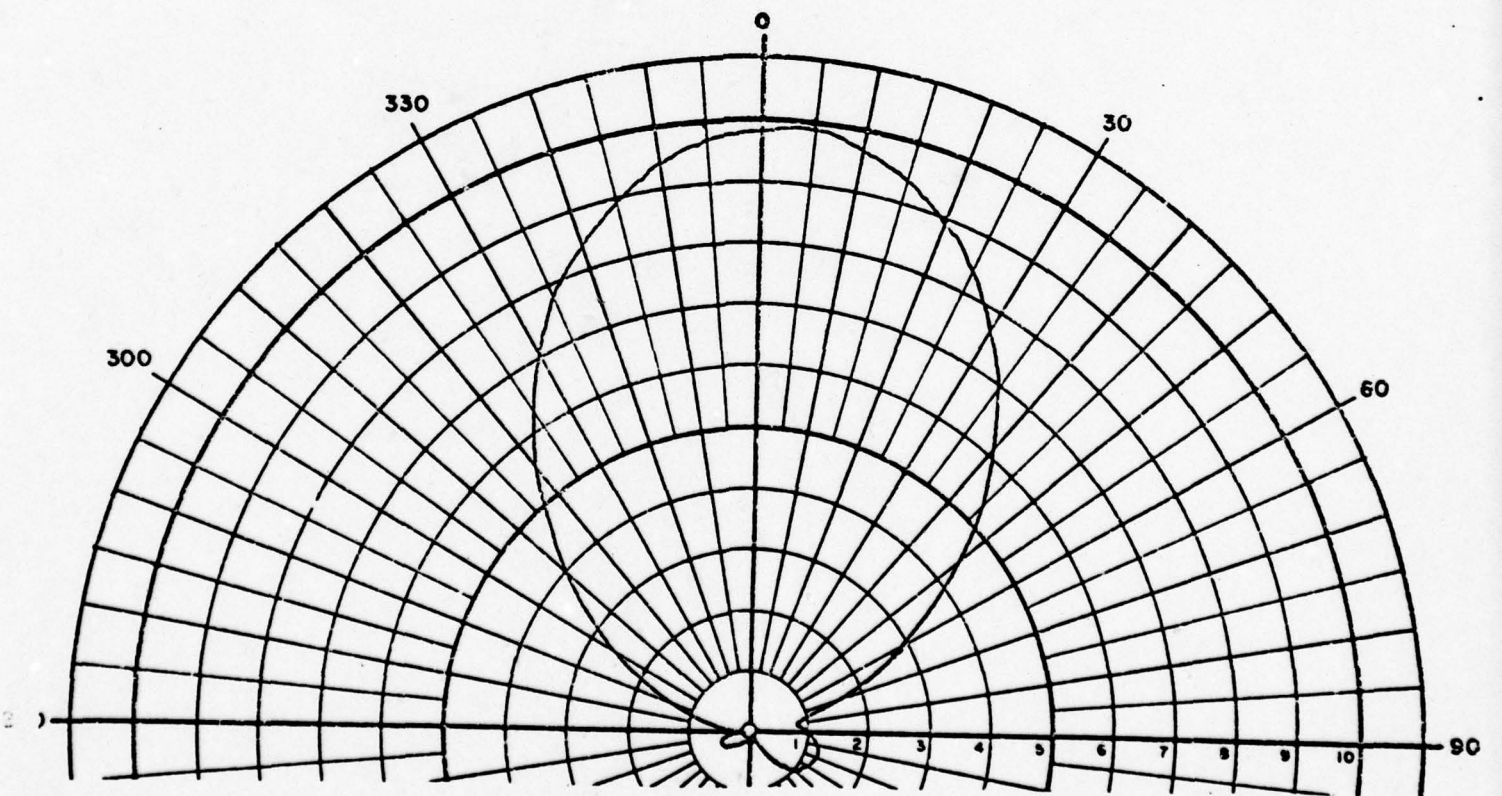

E-Plane

Voltage Patterns, 220 MHz
FIGURE A-5

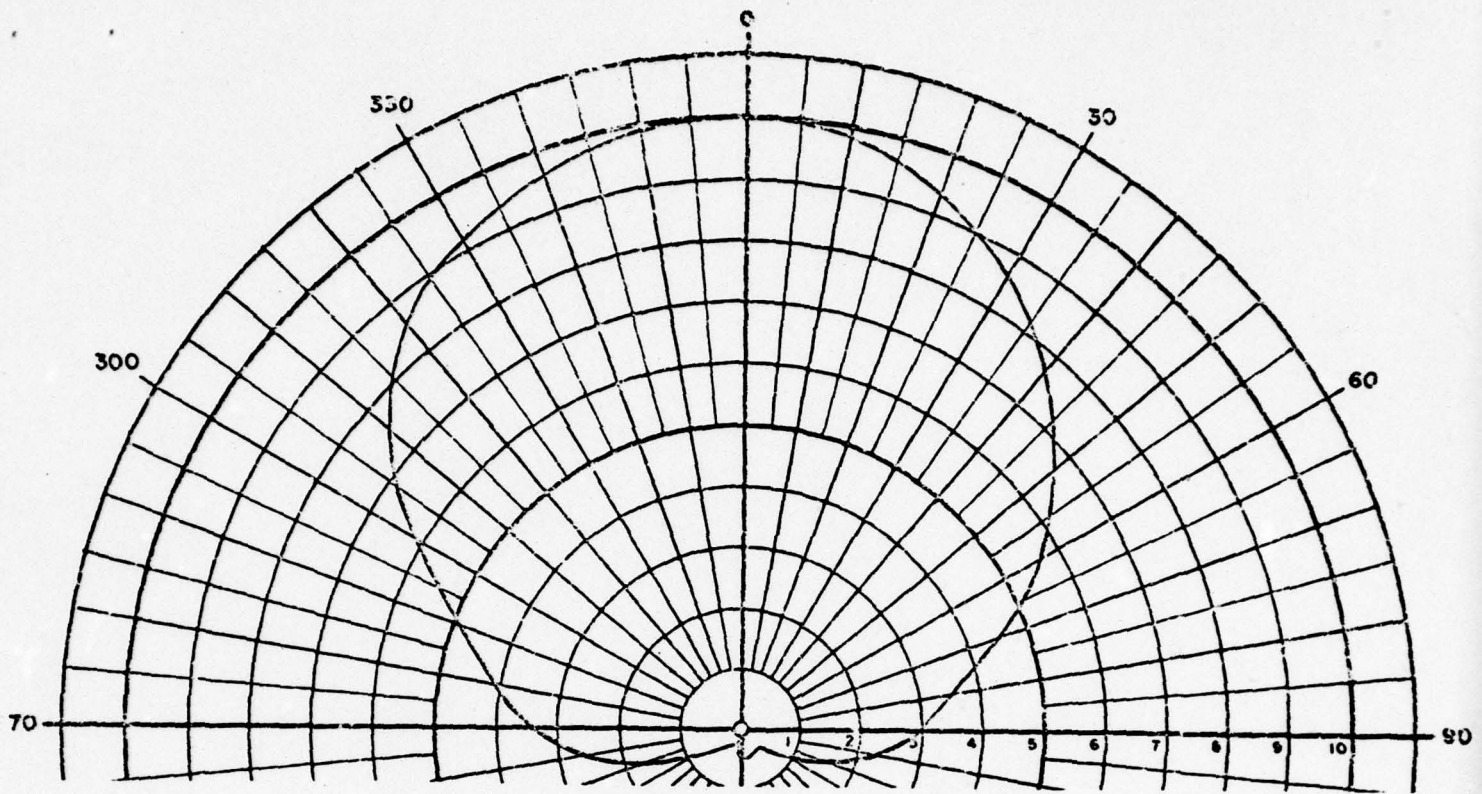

H-Plane

$$\tau = .9$$

$$\alpha = 18.7^\circ$$

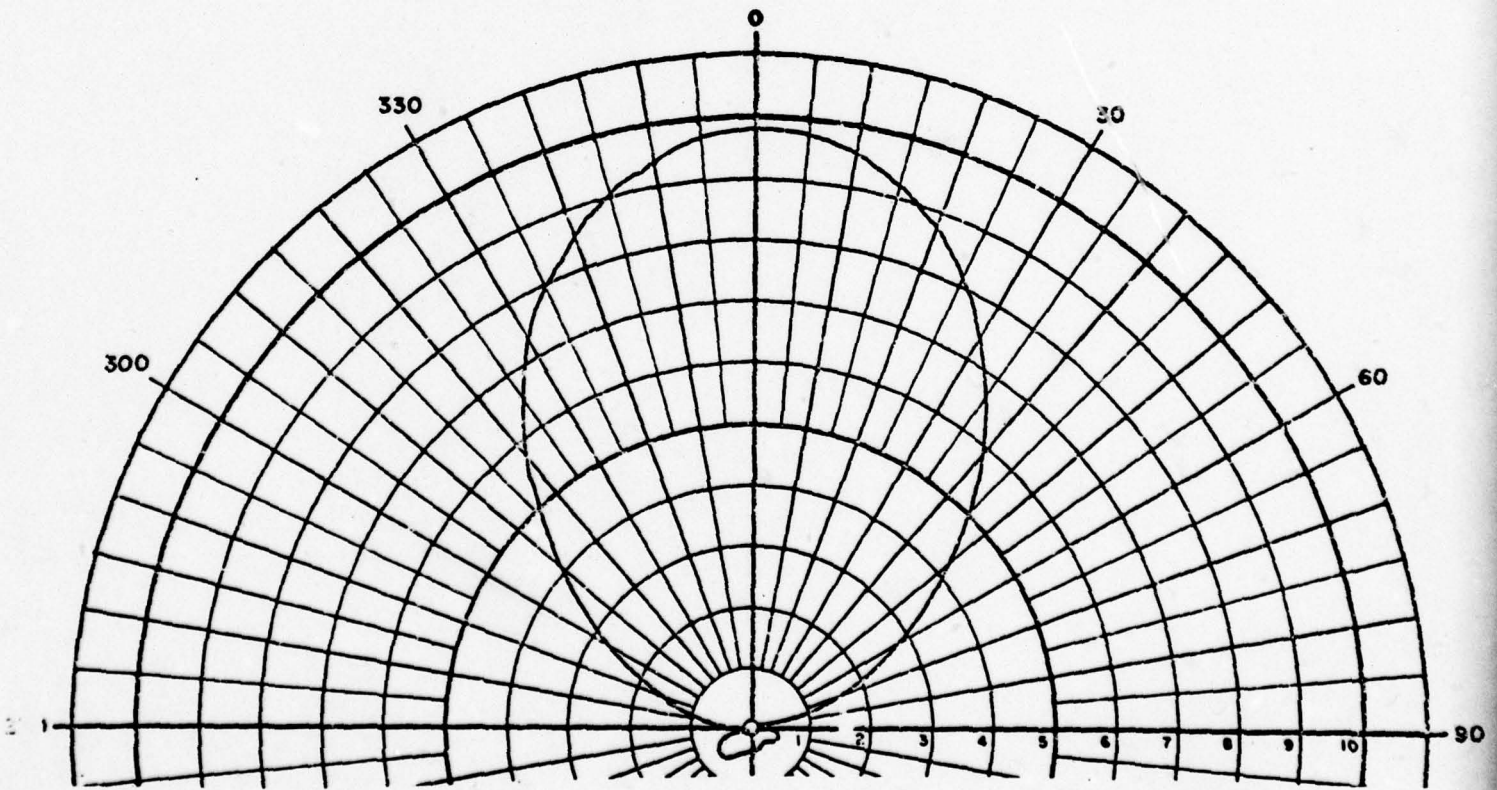

E-Plane

Voltage Patterns, 250 MHz
FIGURE A-6

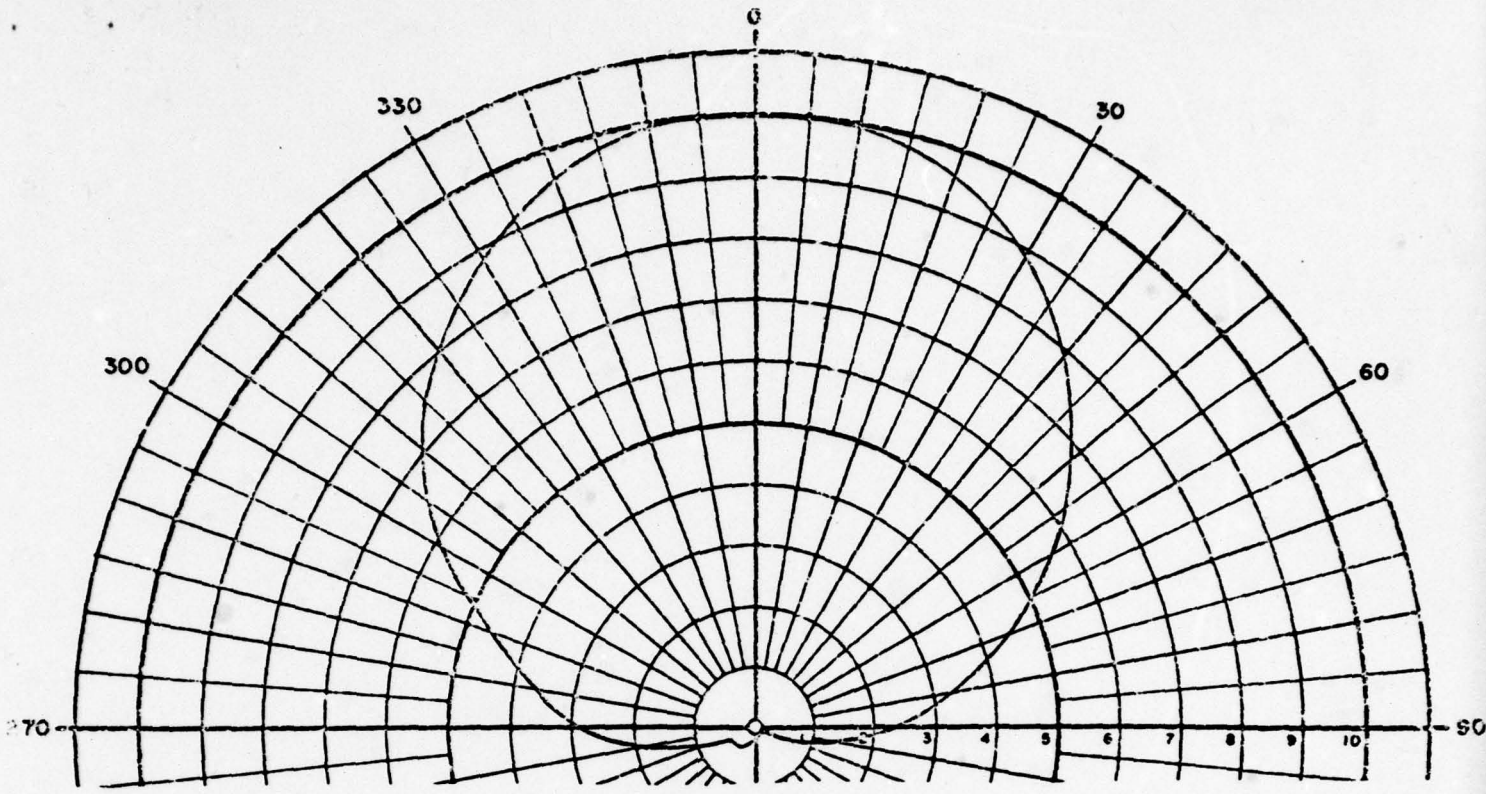

H-Plane

$$\gamma_c = .9$$

$$\alpha = 18.7^\circ$$

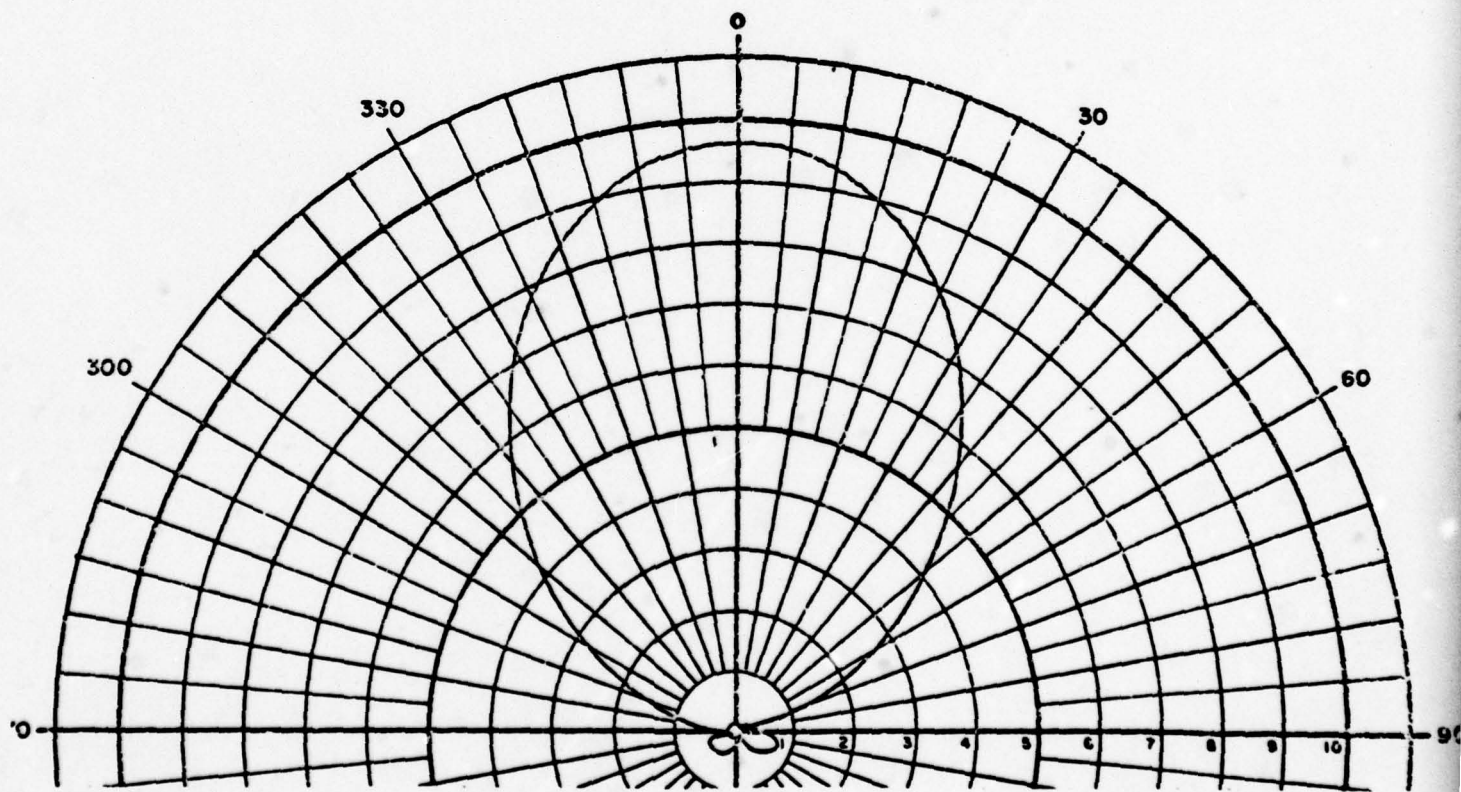

E-Plane

Voltage Patterns, 275 MHz
FIGURE A-7

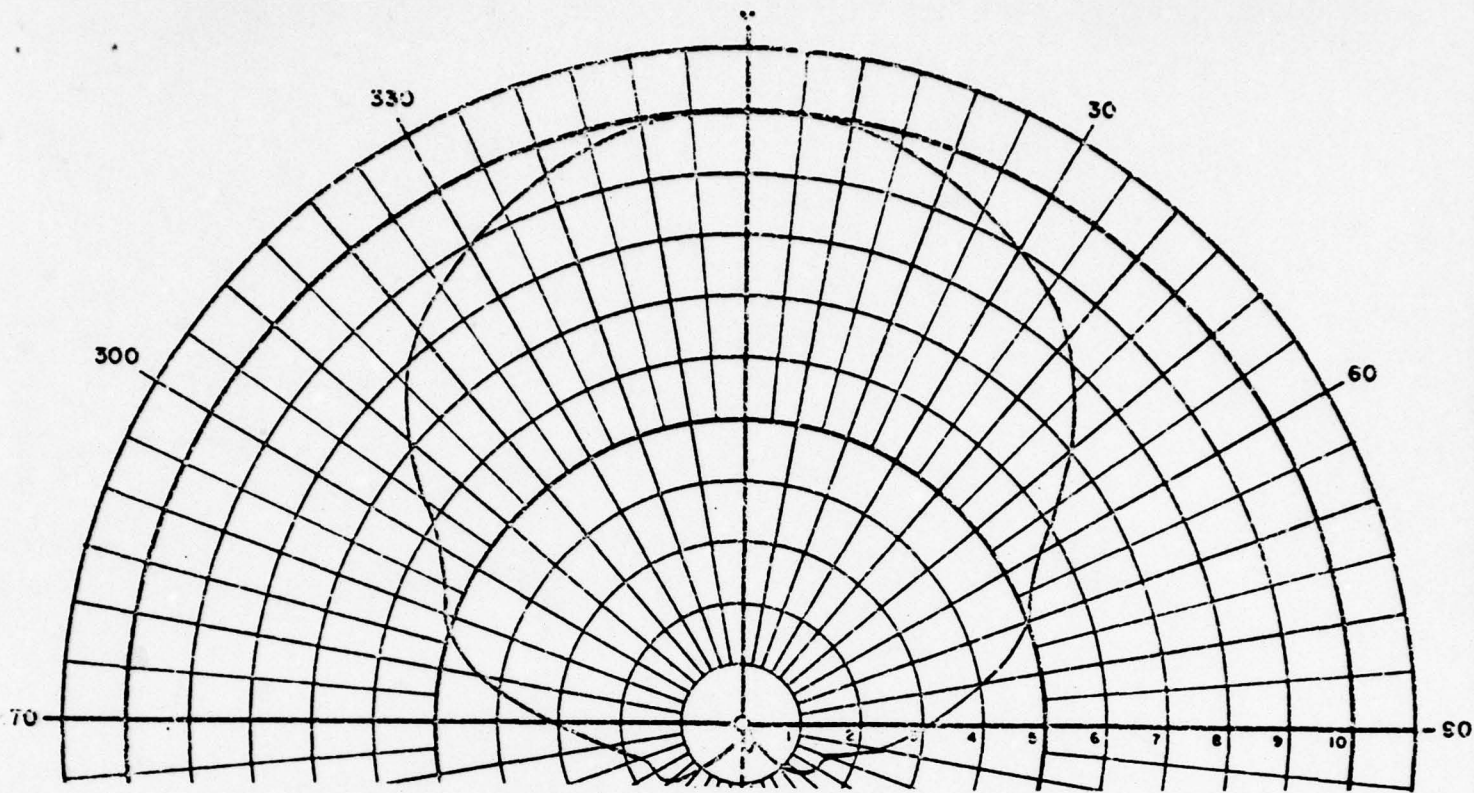

H-Plane

$$\zeta = .9$$

$$\alpha = 18.7^\circ$$

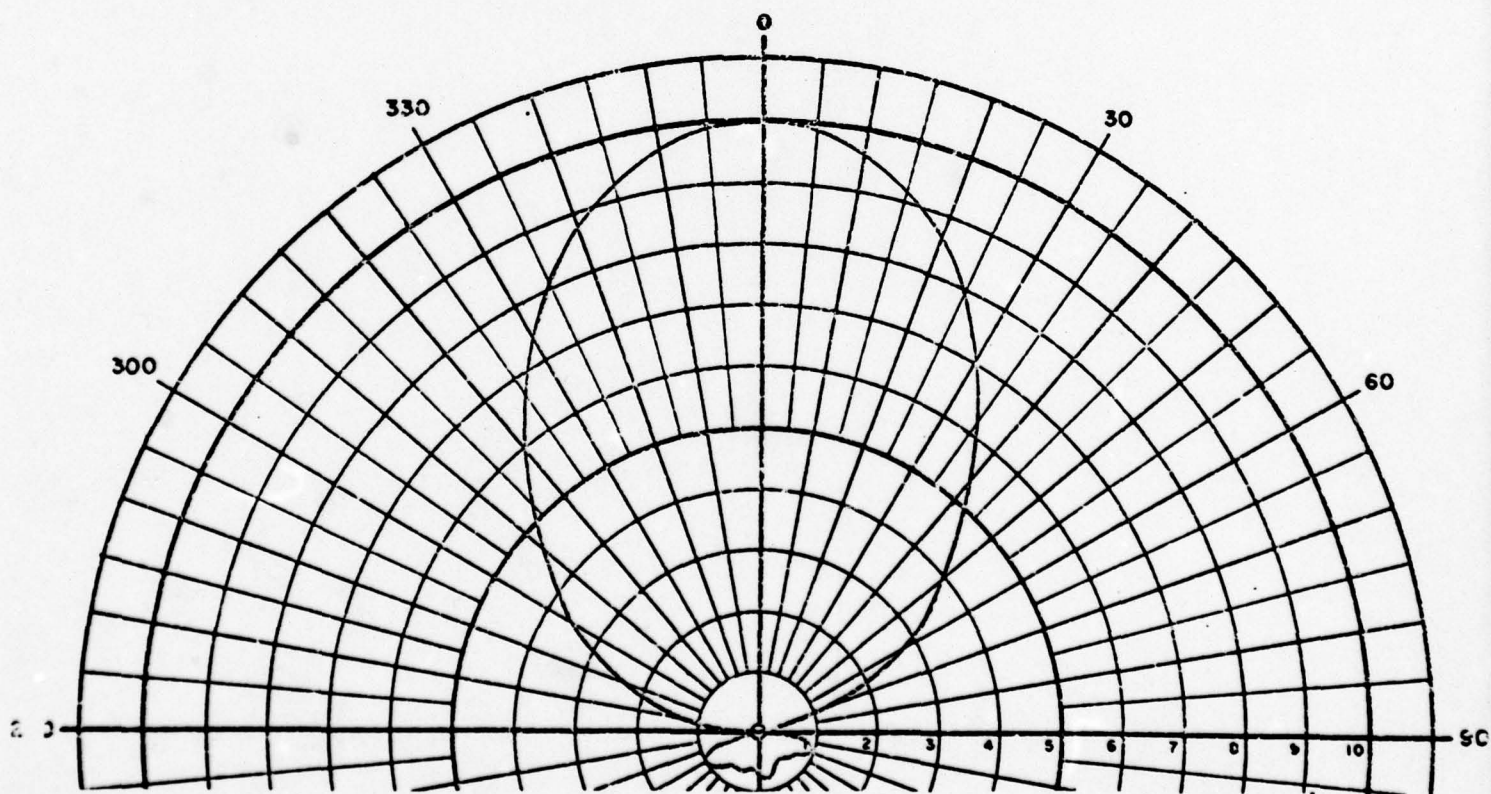

E-Plane

Voltage Patterns, 300 MHz
FIGURE A-8

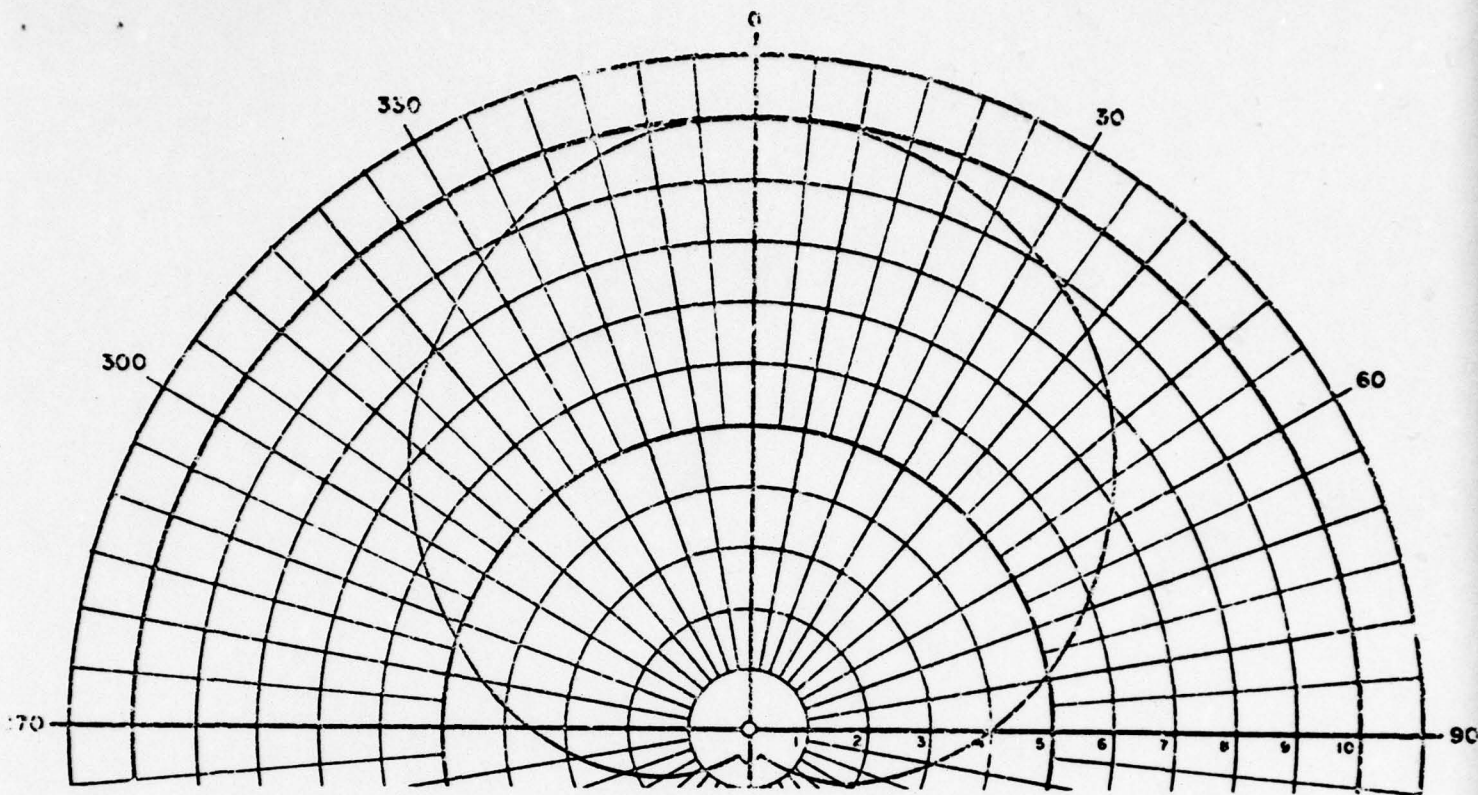

H-Plane

$$\tau = .9$$

$$\alpha = 18.7^\circ$$

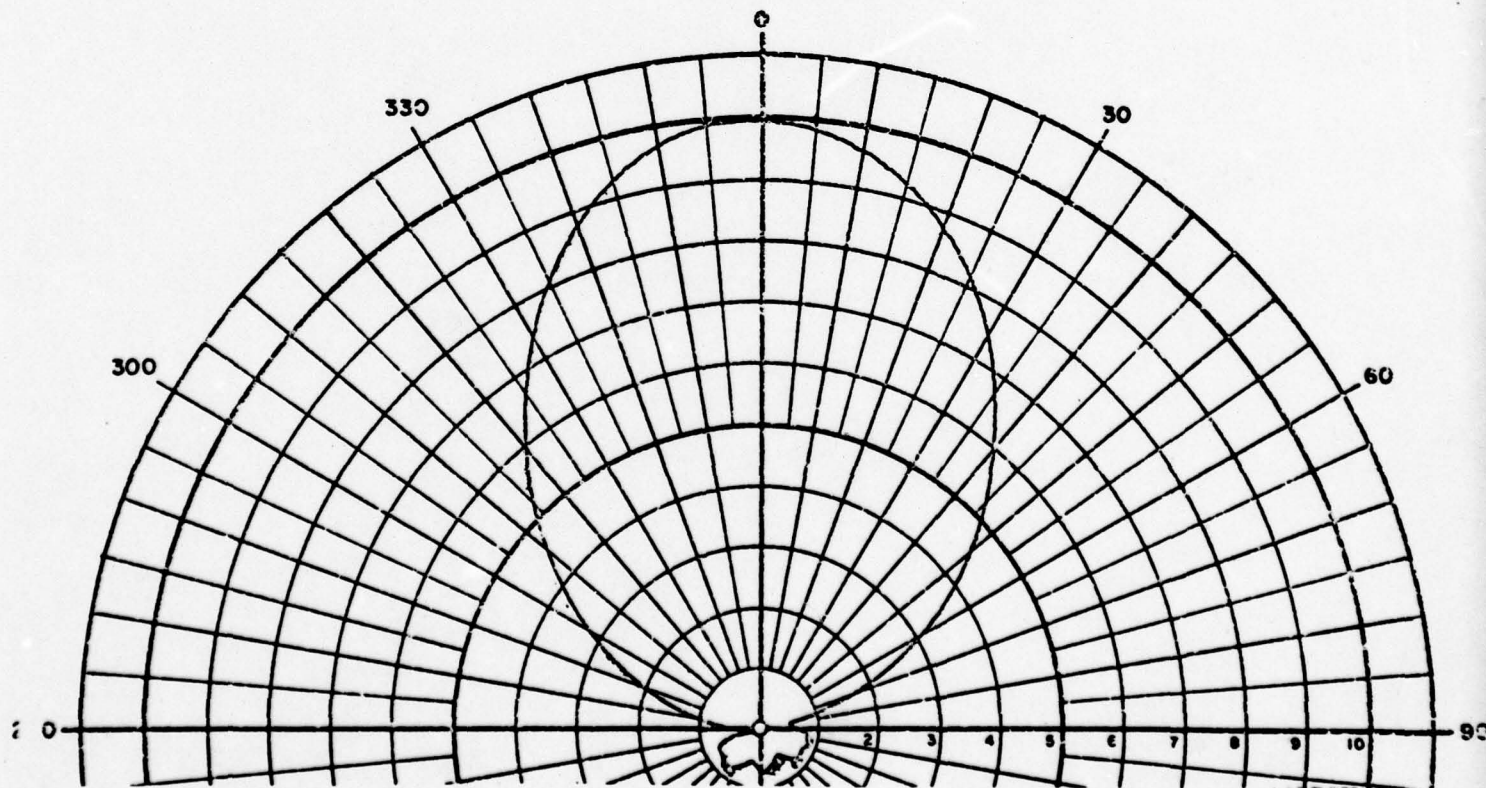

E-Plane

Voltage Patterns, 320 MHz
FIGURE A-9

APPENDIX B

30 - 80 TRANSPORTABLE LOG
PERIODIC ANTENNA WEIGHT ANALYSIS

ELECTROSPACE SYSTEMS, INC

BY: A.G. MEDINA

DOCUMENT NO. 3103-001

DATE: 25 APR. 1972

PAGE 5HT. 1 OF 9

30-80 MHz TRANSPORTABLE LOG PERIODIC
ANTENNA WT. ANALYSIS

THE FOLLOWING IS A PRELIMINARY
ANTENNA WEIGHT ANALYSIS TO
VERIFY THAT THE 30-80 MHz
TRANSPORTABLE LOG PERIODIC
ANTENNA SYSTEM WEIGHS LESS
THAN THE MAXIMUM ALLOWABLE
50 POUNDS.

SHEETS 2 THRU 8 SHOW A BREAK DOWN
OF ALL ANTENNA PARTS AND
THE CALCULATED WEIGHTS.

SHEET 9 SHOWS A WEIGHT
SUMMARY TOTALING THE ANTENNA
WEIGHT.

AS PER SPECIFICATION DS-EH-0050A(A)
PARAGRAPH 3.3.2 WEIGHT.

THE WEIGHT IS FOR ANTENNA
ARRAY ONLY. THIS DOES NOT
INCLUDE (1) MOUNTING BRACKET;
(2) TRANSMISSION LINE; (3) CANVAS
STORAGE BAG AND (4) INSTRUCTION
SHEETS / TEMPLATE.

ELECTROSPACE SYSTEMS, INC

BY: A.G. MEDINA

DOCUMENT NO. 3103-001

DATE: 25 APR. 1972

PAGE 5HT. 2 of 9

30-80 MHz TRANSPORTABLE LOG PERIODIC
ANTENNA WT. ANALYSIS1.0 $\frac{3}{8}$ " ELEMENT MATERIAL ($.00566 \#/\text{IN}$)

ELEMENT NO.	LENGTH IN
1	51.62
2	51.62
3	51.62
4	51.62
5	51.62
6	51.62
7	52.15
8	46.75
9	41.78
10	37.33
11	33.33
12	27.72
13	26.48
14	23.32

$$598.58 \times .00566 = 3.388$$

COMPLETE ELEMENT SET.

$$2 \times 3.388 = \underline{\underline{6.776 \#}}$$

2.0 $\frac{3}{4}$ " DIA. ELEMENT MATERIAL ($.01233 \#/\text{IN}$)

ELEMENT NO.	LENGTH IN
1	53.25
2	42.93
3	33.57
4	25.17
5	17.73
6	10.89

$$185.54 \times .01233 = 2.263 \#$$

ELECTROSPACE SYSTEMS, INC

BY: A. G. MEDINA

DOCUMENT NO. 3103-001

DATE: 25 APR 1972

PAGE 5HT. 5 OF 9

30-80 MHz TRANSPORTABLE LOG PERIODIC
ANTENNA - WT. ANALYSIS

2.0 3/4 DIA. ELEMENT (CONT)

SHORT ROD FOR ELEMENTS 7 THRU 14.

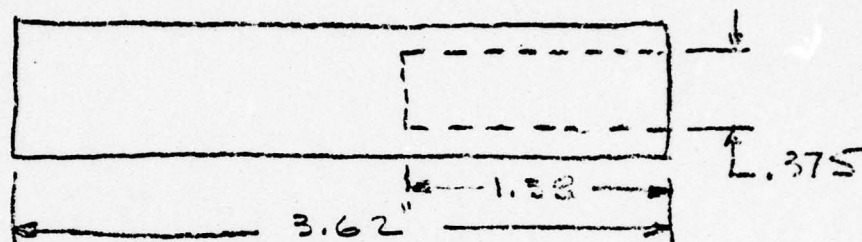

8 ELEMENTS UNIT WT. = .0432 #/IN 3/4
UNIT WT. = .01095 #/IN 3/8

$$WT = [(.0432)(3.62) - (.01095)(1.28)] 8$$

$$= [(.1564) - (.0149)] 8 = \underline{\underline{1.132}} \#$$

$$3/4" \text{ DIA. WT. TOTAL} = 3.395 \times 2 = \underline{\underline{6.79}} \#$$

3.0 ELEMENT TELESCOPING JOINT

ASSUMING A COPPER SLEEVE (.344 #/FT)
.500" O.D. X .062 WALL - X 2.17 LG.

$$WT_{\text{APPROX}} = \left(\frac{.344}{12}\right)(2.17) = 0.06221$$

FOR 12 TELESCOPING ELEMENTS

$$WT_{\text{TOTAL}} = 12 \times 0.06221 = \underline{\underline{0.7465}} \#$$

ELECTROSPACE SYSTEMS, INC

BY: A.G. MEDINA

DOCUMENT NO. E 103-001

DATE: 28 APR.

PAGE SHT. 4 OF 9

30-30 TRANSPORTABLE LOG PERIODIC
ANTENNA WT. ANALYSIS

4.0 ELEMENT CLAMP ASSY; (1) TOP CLAMP
(2) BOTTOM CLAMP (3) CAM (4) CAM SCREW

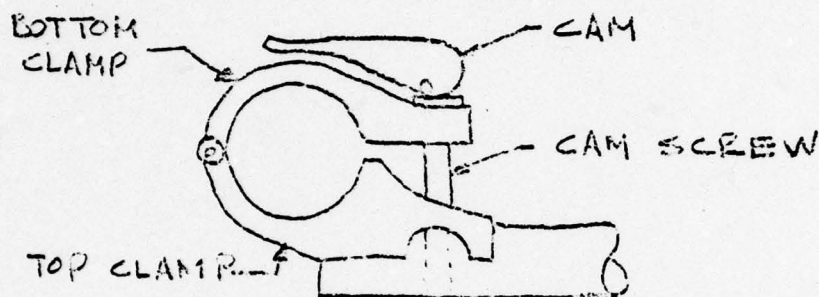

(1) TOP CLAMP

FROM GRAPHICAL DRAWING -

$$\left[\frac{130 \times (.125)^2}{2} \times 1.25 - \frac{\pi R^2 L}{2} \right] (.0954) = W_T$$

(AREA) (LG) (ELEMENT NOTCH)

$$W_{TOP CLAMP} = \left[1.2695 - \frac{(3.1416) \left(\frac{.75}{2}\right)^2 (2.06)}{2} \right] (.0954)$$

$$= (0.8141) (.0954) = \underline{\underline{0.0777}} \#$$

(2) BOTTOM CLAMP

FROM GRAPHICAL DRAWING -

$$\left[\frac{79 \times (.125)^2}{2} \times .859 \right] (.0954) = 0.0506$$

$$W_{BOTTOM CLAMP} = \underline{\underline{0.0506}} \#$$

BY: A. G. MEDINA

DOCUMENT NO. E103-001

DATE: 28 APR.

PAGE 5HT. 5 OF 9

50-80 TRANSPORTABLE LOG PERIODIC
ANTENNA WT. ANALYSIS

4.0 ELEMENT CLAMP ASSY (CONT)

(3) CAM

$$W_{\text{CAM}} = \left[\frac{44 \times (.125)^2}{2} \times .63 \right] \cdot 0.954$$

$$W_{\text{CAM}} = \underline{\underline{0.0266 \#}}$$

(4) CAM SCREW (1/4 DIA. x 2 3/4)

$$W_{\text{CAM SCREW}} = \left(\frac{.167}{12} \right) \times 2.75$$

$$W_{\text{CAM SCREW}} = \underline{\underline{0.03827 \#}}$$

TOTALS - (1) TOP CLAMP	-	0.0777
(2) BOTTOM CLAMP	-	0.0506
(3) CAM	-	0.0266
(4) CAM SCREW	-	0.03827
		<hr/>
		0.1932

FOR 28 CLAMPS

$$0.1932 \times 28 = \underline{\underline{5.4098 \#}}$$

ELECTROSPACE SYSTEMS, INC

BY: A. G. MEDINA

DOCUMENT NO. 5103-001

DATE: 28 APR. 1972

PAGE 5HT. 6 OF 9

30-80MH₂ TRANSPORTABLE LOG PERIODIC
ANTENNA WT. ANALYSIS

5.0 ANTENNA BOOM

AL TUBE 1.50 O.D. X 0.058 WALL

$$WT = 0.309 \text{ \# / FT}$$

3 BOOM SECTIONS @ 5.0'

1 BOOM SECTION @ 4.82'

$$(3 \times 5) + 4.82 = 19.82 \text{ UPPER BOOM}$$

x 2

$$\underline{\underline{39.64 \text{ FT TOTAL}}}$$

$$W_{T \text{ BOOM}} = (0.309)(39.64) = \underline{\underline{12.2488 \text{ \#}}}$$

6.0 ANTENNA FEED POINT / TRANSFORMER

(1) CONNECTOR TUBE; (2) FEED STRAP AND
(3) TRANSFORMER

(1) CONNECTOR TUBE (1.375 O.D. X 2 LG.)

$$WT = \frac{.292}{12} \times 2 = \underline{\underline{0.047 \text{ \#}}}$$

(2) FEED STRAP - 0.062 X 5.63 X 1.5

$$WT = (0.062)(5.63)(1.5)(.0954) = \underline{\underline{0.050 \text{ \#}}}$$

(3) TRANSFORMER

$$W_{T \text{ APPROX}} = \underline{\underline{0.10 \text{ \#}}}$$

$$W_{T \text{ ANTENNA FEED POINT}} = \underline{\underline{0.197 \text{ \#}}} \text{ TOTAL}$$

30-80 MHz TRANSPORTABLE LOG PERIODIC
ANTENNA WT. ANALYSIS

7.0 BOOM CLAMP

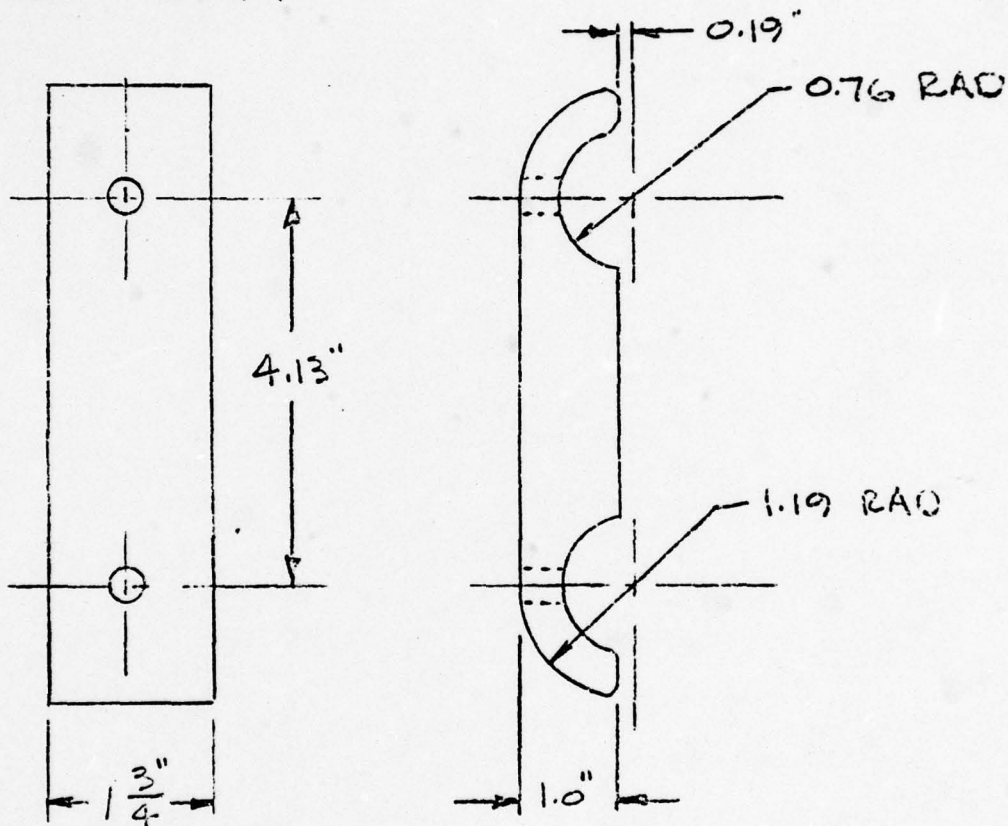

$$\text{MATERIAL DENSITY} = 0.04586 \text{ \#/IN}^3$$

$$W_{\text{APPROX}} = 0.04586 \left[(1.75) \overset{11.7425}{(6.71)} (1.0) - (3.1416) \overset{3.1755}{(0.76)}^2 (1.75) \right. \\ \left. - (2) \overset{1.0636}{(0.2146)} (1.19)^2 (1.75) \right]$$

$$W_{\text{APPROX}} = (0.04586)(7.5034) = 0.3441 \text{ \#}$$

$$20 \text{ PARTS} = \underline{\underline{6.882 \text{ \# TOTAL}}}$$

ELECTROSPACE SYSTEMS, INC

BY: A.G. MEDINA

DOCUMENT NO. 8108-001

DATE: 28 APR. 1972

PAGE SHT. 8 OF 9

20-50 MHz TRANSPORTABLE LOG PERIODIC
ANTENNA WT. ANALYSIS8.0 $\frac{3}{8}$ " DIA. BOOM CLAMP PINS - STAINLESS

$$WT = 0.376 \text{ #/FT} - \text{PIN } 2.75" \text{ LG.}$$

$$WT_{\text{PIN}} = \frac{0.376}{12} \times 2.75 = 0.0832 \text{ #}$$

$$20 \text{ PINS} = \underline{\underline{1.7233}} \text{ # TOTAL}$$

9.0 CLAMP BOLT ASSY.

(1) BOLT ; (2) SPECIAL NUT; (3) HANDLE

(1) BOLT - $\frac{5}{16}$ -18 X 2.5 LG.

$$WT_{\text{BOLT}} = \frac{.261}{12} \times 2.5 = 0.05437$$

$$20 \text{ BOLTS} = \underline{\underline{1.0875}} \text{ # TOTAL}$$

(2) HANDLE

$$WT_{\text{HANDLE}} = \frac{.094}{12} \times 3.70 = 0.02898$$

$$20 \text{ HANDLES} = \underline{\underline{0.5797}} \text{ # TOTAL}$$

(3) SPECIAL NUT

$$WT_{\text{NUT}} = \frac{.495}{12} \times 1.1 = 0.04538$$

$$20 \text{ NUTS} = \underline{\underline{0.9075}} \text{ #}$$

$$WT_{\text{CLAMP BOLT ASSY}} = \underline{\underline{2.5747}} \text{ # TOTAL}$$

ELECTROSPACE SYSTEMS, INC

BY: A. G. MEDINA

DOCUMENT NO. E105-001

DATE: 28 APR. 1972

PAGE 2 OF 9

30-80 MHz TRANSPORTABLE LOG PERIODIC
ANTENNA WT ANALYSIS

10.0 ANTENNA WEIGHT SUMMARY

1.0	3/8" ELEMENT MATL	---	6.7760
2.0	3/4 " "	---	6.7900
3.0	ELEMENT JOINT	---	0.7465
4.0	ELEMENT CLAMP ASSY	---	5.4088
5.0	ANTENNA BOOM	---	12.2433
6.0	ANTENNA FEED POINT	---	0.1970
7.0	BOOM CLAMP	---	6.8820
8.0	3/8" DIA. CLAMP	---	1.7232
9.0	CLAMP BOLT ASSY	---	2.5747

TOTAL ANTENNA WT LESS
FINISH

43.3471

BY: A.G. MEDINA

DOCUMENT NO. E/08-001

DATE: 18 APR. 1972

PAGE 1 OF 30

30-80 MHz TRANSPORTABLE LOG PERIODIC ANTENNA STRESS ANALYSIS

THE FOLLOWING IS A PRELIMINARY ANTENNA STRESS ANALYSIS TO VERIFY THAT THE ANTENNA DESIGN IS IN COMPLIANCE WITH SPEC REQUIREMENTS AS TO ENVIRONMENTAL LOADING AND THAT ALL ANTENNA LOADS DO NOT STRESS ANTENNA PARTS BEYOND ALLOWABLE STRESS LEVELS:

THE ALUMINIUM ASSOCIATION SPECIFICATIONS FOR ALUMINIUM STRUCTURES IS USED AS THE GUIDE FOR ALLOWABLE STRESS LEVELS.

RS 222 IS USED TO CALCULATE WIND LOADS.

AS THE DESIGN IS FINALIZED, THE STRESS ANALYSIS WILL BE REVIEWED AND UP DATED TO INSURE THAT ALL CRITICAL STRESS AREAS ARE ANALYZED.

ELECTROSPACE SYSTEMS, INC

BY: A.G. MEDINA

DOCUMENT NO. 2103-000

DATE: 18 APR. 1972

PAGE 2 OF 30

30-80 MHz TRANSPORTABLE LOG PERIODIC
ANTENNA STRESS ANALYSIS

LOAD CONDITIONS AND CASES

WIND DIRECTION

ANTENNA TOP VIEWS

HORIZONTAL
POSITION

VERTICAL
POSITION

CONDITION "A"

50MPH
1/4" ICE

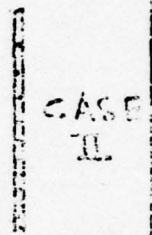
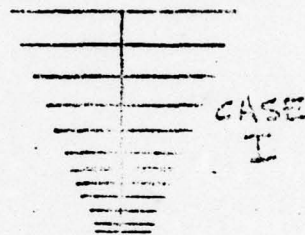

CONDITION "B"

75MPH
NO ICE

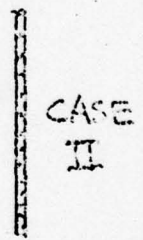

CONDITION "A"

50MPH
1/4" ICE

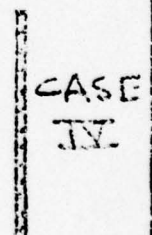
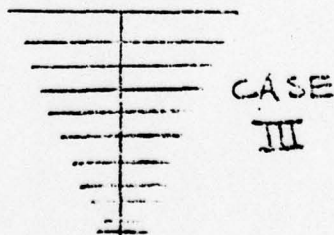

CONDITION "B"

75 MPH
NO ICE

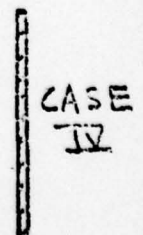
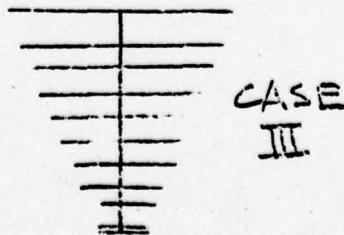

ELECTROSPACE SYSTEMS, INC

BY: A.G. MEDINA

DOCUMENT NO. E-103-002

DATE: 18 APR. 1972

PAGE 3 OF 50

50-50 MHz TRANSPORTABLE LOG PERIODIC
ANTENNA STRESS ANALYSIS

1.1 WIND LOAD CALCULATIONS.

USING EIA STANDARD RS-222A FOR
WIND PRESSURE CALCULATIONS

$$P = 0.004 V^2 \quad \text{WHERE: } P = \text{PRESSURE PSF}$$

(FOR FLAT SURFACES) $V = \text{WIND VELOCITY, MPH}$

1.1.1 WIND LOAD CONDITION "A"
50 MPH

$$P = 0.004 (50)^2$$

$$P = 10 \text{ PSF (FOR FLAT SURFACES)}$$

$$P = \frac{2}{3} (10) = 6.66 \text{ PSF (FOR ROUND SURFACES)}$$

$$P = \frac{6.66}{144} = \underline{\underline{0.0463 \text{ PSI}}}$$

1.1.2 WIND CONDITION "B"
75 MPH

$$P = 0.004 (75)^2$$

$$P = 22.5 \text{ PSF (FOR FLAT SURFACES)}$$

$$P = \frac{2}{3} (22.5) = 15 \text{ PSF (FOR ROUND SURFACES)}$$

$$P = \frac{15.0}{144} = \underline{\underline{0.1042 \text{ PSI}}}$$

30-80 MHz TRANSPORTABLE LOG PERIODIC
ANTENNA STRESS ANALYSIS

2.0 ANTENNA FRONTAL AREA NO ICE

2.1 $\frac{3}{8}$ " DIA. ELEMENT WITHOUT ICE AREA

ELE NO.	EXPOSED LENGTH
1	49.62
2	
3	
4	
5	
6	
7	50.77
8	45.37
9	40.40
10	35.95
11	31.95
12	26.34
13	25.10
14	21.94
	<hr/>
	575.54

$$A_{F \frac{3}{8}} = (575.54)(\pi)(.375) = \underline{\underline{431.655 \text{ IN}^2}}$$

2.2 $\frac{3}{4}$ " DIA. ELEMENT W/O ICE AREA

ELE. NO.	EXPOSED LENGTH
1	53.25
2	42.93
3	33.57

ELECTROSPACE SYSTEMS, INC

BY: A. G. MEDINA

DOCUMENT NO. 3123-002

DATE: 18 APRIL 1972

PAGE 5 OF 30

30-80 MHz TRANSPORTABLE LOG PERIODIC
ANTENNA STRESS ANALYSIS2.2 $\frac{3}{4}$ " DIA. ELEMENT W/O ICE AREA

ELE. NO.	EXPOSED LENGTH
4	25.17
5	17.73
6	10.89
7	3.62
8	
9	
10	
11	
12	
13	
14	3.62
	<u>212.50</u>

$$A_{F\frac{3}{4}} = 212.5 \times 2 \times .75 = \underline{\underline{318.75 \text{ IN}^2}}$$

2.3 $1\frac{1}{2}$ " DIA. BOOM SECTIONS

BOOM LENGTH = 19.045 FT.

$$A_{F_{\text{BOOM}}} = (19.045) (12) (2) (1.5) = \underline{\underline{685.626 \text{ IN}^2}}$$

$$A_{F_{\text{TOTAL}}} = A_{F\frac{3}{8}} + A_{F\frac{3}{4}} + A_{F_{\text{BOOM}}}$$

$$= 431.655 + 318.75 + 685.626 = \underline{\underline{1690. \text{ IN}^2}}$$

ELECTROSPACE SYSTEMS, INC

BY: A. G. MEDINA

DOCUMENT NO. 3103-002

DATE: 18 APR. 1972

PAGE 6 OF 30

30-30 MHz TRANSPORTABLE LOG PERIODIC
ANTENNA STRESS ANALYSIS

3.0 ANTENNA FRONTAL AREA WITH ICE

3.1 3/8" DIA. ELEMENT WITH ICE AREA

$$A_{F_{\frac{3}{8} + \frac{1}{4} \text{ICE}}} = (575.54)(2)(.875) \\ = \underline{\underline{1007.195 \text{ IN}^2}}$$

3.2 3/4" DIA. ELEMENT WITH ICE AREA

$$A_{F_{\frac{3}{4} + \frac{1}{4} \text{ICE}}} = (212.50)(2)(1.25) \\ = \underline{\underline{531.25 \text{ IN}^2}}$$

3.3 1 1/2" DIA. BOOM SECTIONS WITH ICE AREA

$$A_{F_{\text{BOOM} + \frac{1}{4} \text{ICE}}} = (19.045)(2)(12)(2.0) \\ = \underline{\underline{914.16 \text{ IN}^2}}$$

TOTAL FRONTAL AREA WITH 1/4 IN ICE

$$A_{F_{\text{TOTAL}}} = A_{F_{\frac{3}{8} + \frac{1}{4} \text{ICE}}} + A_{F_{\frac{3}{4} + \frac{1}{4} \text{ICE}}} + A_{F_{\text{BOOM} + \frac{1}{4} \text{ICE}}}$$

$$A_{F_{\text{TOTAL}}} = 1007.195 + 531.25 + 914.16 \\ = \underline{\underline{2452.605 \text{ IN}^2}}$$

ELECTROSPACE SYSTEMS, INC

BY: A. G. MEDINA

DOCUMENT NO. 3103-002

DATE: 13 APR. 1977

PAGE 7 OF 30

30-80 MHz TRANSPORTABLE LOG PERIODIC
ANTENNA STRESS ANALYSIS4.0 ANTENNA SHEAR LOAD UNDER
CONDITION "A" CASE IV

$$\begin{aligned}
 V_{A_{IV}} &= P_A A_{F_{A_{IV}}} \\
 &= (0.0463)(2452.605) \\
 &= \underline{\underline{113.56 \#}}
 \end{aligned}$$

5.0 ANTENNA SHEAR LOAD UNDER
CONDITION "B" CASE IV

$$\begin{aligned}
 V_{B_{IV}} &= P_B A_{F_{B_{IV}}} \\
 &= (0.1042)(1690) \\
 &= \underline{\underline{176.1 \#}}
 \end{aligned}$$

6.0 ANTENNA ICE WT.

DENSITY OF ICE $\rho = 0.0332 \#/\text{IN}^3$ 6.1 $\frac{2}{3}$ " ELEMENT ICE.ICE AREA = $A_{\frac{2}{3}} = 0.491 \text{ IN}^2$

$$W_{T_{\frac{2}{3}}} = (0.491)(575.54)(0.0332)(2) = \underline{\underline{18.764 \#}}$$

BY: A.G. MEDINA

DOCUMENT NO. 5103-002

DATE: 12 APR 1972

PAGE 3 OF 30

20-30 MHz TRANSPORTABLE LOG PERIODIC
ANTENNA STRESS ANALYSIS6.2 $\frac{3}{4}$ " ELEMENT ICE

$$\text{ICE AREA} = 1.0 \text{ IN}^2$$

$$\begin{aligned} W_{T, \frac{3}{4}} &= (1.0)(212.50)(2)(.0332) \\ &= \underline{\underline{14.11 \#}} \end{aligned}$$

6.3 $1\frac{1}{2}$ " DIA. BOOM ICE

$$\text{ICE AREA} = 1.3746 \text{ IN}^2$$

$$\begin{aligned} W_{T, \text{BOOM}} &= (1.3746)(19.045)(2)(2)(.0332) \\ &= \underline{\underline{20.86 \#}} \end{aligned}$$

TOTAL ICE WT

$$\begin{aligned} W_{T, \text{TOTAL}} &= W_{T, \frac{3}{4}} + W_{T, \frac{3}{4}} + W_{T, \text{BOOM}} \\ &= 13.764 + 14.11 + 20.86 \\ &= \underline{\underline{53.734 \#}} \end{aligned}$$

$$\begin{aligned} \text{FROM WT ANALYSIS ANT. WT} &= 43.347 \\ \text{TOTAL ANT. WT WITH ICE} &= \underline{\underline{97.081 \#}} \end{aligned}$$

50-80 MHz TRANSPORTABLE LOG PERIODIC
ANTENNA STRESS ANALYSIS

7.0 ANTENNA ARRAY MAX SHEAR LOADS

7.1 ANTENNA LOADS UNDER CONDITION "A"
CASE IV

RESULTANT ANTENNA SHEAR

$$V_{RAIV} = \sqrt{(WT_{AIV})^2 + (V_{AIV})^2}$$

$$V_{RAIV} = \sqrt{(97.031)^2 + (113.56)^2}$$

$$V_{RAIV} = \underline{\underline{149.4}} \#$$

7.2 ANTENNA LOADS UNDER CONDITION "B"
CASE IV

RESULTANT ANTENNA SHEAR

$$V_{RBIIV} = \sqrt{(WT_{BIV})^2 + (V_{BIV})^2}$$

$$V_{RBIIV} = \sqrt{(43.347)^2 + (176.1)^2}$$

$$V_{RBIIV} = \underline{\underline{181.4}} \#$$

ELECTROSPACE SYSTEMS, INC

BY: A. G. MELINA

DOCUMENT NO. 5103-002

DATE: 18 APR. 1972

PAGE 10 OF 30

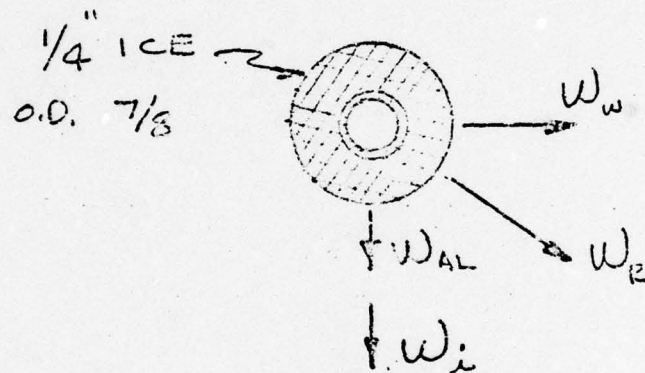
30-50 MHz TRANSPORTABLE LOG PERIODIC
ANTENNA STRESS ANALYSISS.O LOAD ANALYSIS - UNDER CONDITION "A"
CASE IS.1 FIND ELEMENT LOADS - $\frac{3}{8}$ " $\frac{3}{8}$ " DIA. X.058 WALL ELEMENT

$$W_{R_{\frac{3}{8}}} = \sqrt{(W_w)^2 + (W_{AL} + W_i)^2}$$

WHERE:

 W_R = RESULTANT ELEMENT UNIT LOAD #/IN W_w = WIND LOAD #/IN W_{AL} = ALUMINUM ELEMENT WT #/IN W_i = ICE LOAD #/IN

$$W_{w_{\frac{3}{8}}} = \rho d_{\frac{7}{8}}$$

$$W_{w_{\frac{3}{8}}} = (0.0463)(.375) = 0.0405 \text{ #/IN}$$

BY: A.G. MEDINA

DOCUMENT NO. 3103-01

DATE: 15 APR. 1972

PAGE 11 OF 30

50-80 MHz TRANSPORTABLE LOG PERIODIC
ANTENNA STRESS ANALYSIS

E.1 FIND ELEMENT LOADS (CONT)

$$W_{AL \frac{2}{3}} = 0.00566 \text{ \#/IN (AL. DATA BOOK)}$$

$$W_{L \frac{2}{3}} = \frac{\pi}{4} \rho_i (d_o^2 - d_i^2) \quad \text{WHERE:}$$

 ρ_i = ICE DENSITY

$$W_{L \frac{2}{3}} = \frac{3.14}{4} (.0232 \left[(.375)^2 - (.275)^2 \right]) \quad \begin{matrix} d_o = \text{OUTSIDE} \\ \text{DIA. ICE} \end{matrix}$$

 d_i = INSIDE
DIA. ICE

$$W_{L \frac{2}{3}} = 0.0162 \text{ \#/IN}$$

$$W_{R \frac{2}{3}} = \sqrt{(0.0405)^2 + (.00566 + .0162)^2}$$

.02196

$$W_{R \frac{2}{3}} = 0.0461 \text{ \#/IN}$$

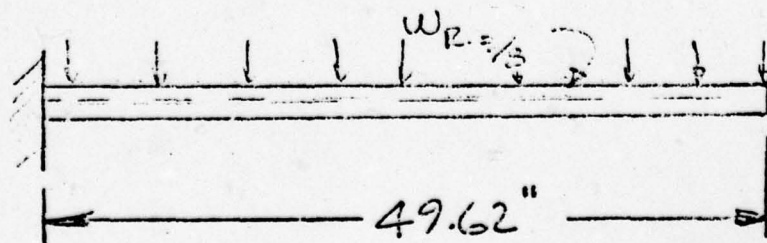

ELECTROSPACE SYSTEMS, INC

BY: A. S. MELINA

DOCUMENT NO. 3108-001

DATE: 18 APR. 1972

PAGE 12 OF 30

20-50 MHz TRANSPORTABLE LOG-PERIODIC
ANTENNA STRESS ANALYSIS2.2 FIND MAX. ELEMENT MOMENT " $\frac{3}{8}$ "

$$M_{R\frac{3}{8}} = \frac{WR_{\frac{3}{8}} l^2}{2}$$

$$= \frac{(0.0461)(49.62)^2}{2}$$

$$= \underline{\underline{56.6 \text{ IN-}\#}}$$

2.3 FIND MAX. ELEMENT STRESS - " $\frac{3}{8}$ "

$$S_{R\frac{3}{8}} = M_{R\frac{3}{8}} / Z_{\frac{3}{8}}$$

$$S_{R\frac{3}{8}} = 56.6 / .004 = \underline{\underline{14,150 \text{ PSI}}}$$

2.4 FIND ELEMENT LOADS - " $\frac{3}{4}$ "

$$W_{R\frac{3}{4}} = \sqrt{(W_{w\frac{3}{4}})^2 + (W_{AL\frac{3}{4}} + W_{I\frac{3}{4}})^2}$$

20-30 MHz TRANSPORTABLE LOG-PERIODIC
ANTENNA STRESS ANALYSIS

5.4 FIND ELEMENT LOAD - $\frac{3}{4}$ (CONT)

$$W_{\frac{3}{4}} = \rho d_{\frac{1}{4}}$$

$$W_{\frac{3}{4}} = 0.0463 (1.25) = 0.0579 \text{ \#/IN}$$

$$W_{AL \frac{3}{4}} = 0.01233 \text{ \#/IN (AL DATA HANDBOOK)}$$

$$W_{I \frac{3}{4}} = \frac{3.14}{4} (0.0222) \left[\frac{(1.25)^2 - (.75)^2}{1.00} \right]$$

$$W_{I \frac{3}{4}} = 0.0261 \text{ \#/IN}$$

$$W_{R \frac{3}{4}} = \sqrt{(.0579)^2 + (.01233 + .0261)^2}$$

.03843

$$W_{R \frac{3}{4}} = 0.0695 \text{ \#/IN}$$

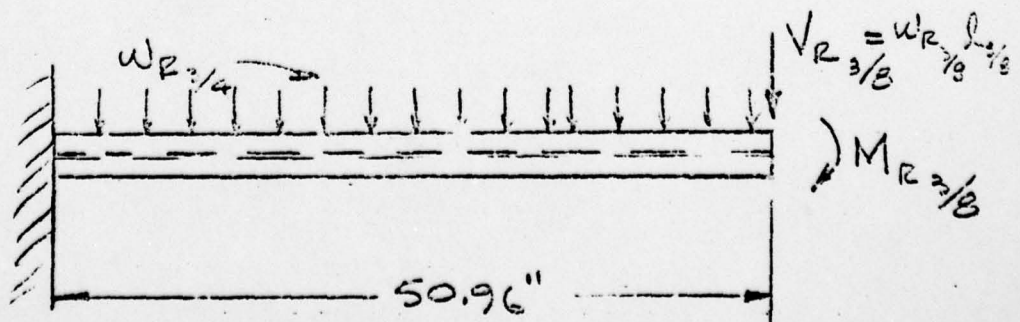

30-80 MHz TRANSPORTABLE LOG-PERIODIC
ANTENNA STRESS ANALYSIS

8.5 FIND MAX ELEMENT MOMENT "3/4"
ASSUME MOMENT IS ON SAME PLANE

$$M_{R_{3/4}} = \frac{W_{R_{3/4}} l^{3/4}}{2} + V_{R_{3/4}} l^{3/4} + M_{R_{3/4}}$$

$$= \frac{(0.095)(50.96)^{90.2}}{2} + (0.461)(49.62)^{116.2}(50.96)$$

$$+ 56.6 \text{ IN-#}$$

$$M_{R_{3/4}} = \underline{\underline{263 \text{ IN-#}}}$$

8.6 FIND MAX ELEMENT STRESS - 3/4"

$$S_{R_{3/4}} = M_{R_{3/4}} / Z_{3/4}$$

$$S_{R_{3/4}} = 263 / .0203 = \underline{\underline{12,970 \text{ PSI}}}$$

ANTENNA ELEMENT STRESSES
ARE WELL UNDER THE
ALLOWABLE 25,000 PSI

50-FOOT TRANSPORTABLE LOG-PERIODIC
ANTENNA STRESS ANALYSIS8.7 FIND DIRECTION OF RESULTANT
MAY. ELEMENT MOMENTDUE TO $\frac{3}{8}$ " ELEMENT

$$\phi_{\frac{3}{8}} = \text{ARC TAN } \frac{.02196}{.0405} = .5422$$

$$\phi_{\frac{3}{8}} = 28^{\circ} 23'$$

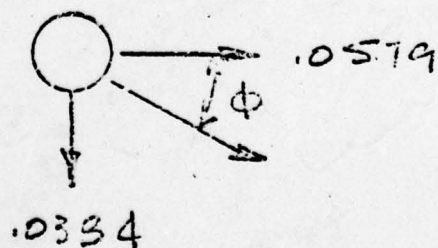
DUE TO $\frac{3}{4}$ " ELEMENT

$$\phi_{\frac{3}{4}} = \text{ARC TAN } \frac{.0384}{.0579} = 0.6632$$

$$\phi_{\frac{3}{4}} = 33^{\circ} 33'$$

BY: A. G. MEDINA

DOCUMENT NO. 3103-002

DATE: 30 APR 1972

PAGE 14 OF 30

30-30 MHz TRANSPORTABLE LOG PERIODIC ANTENNA STRESS ANALYSIS

5.7 FIND DIRECTION OF RESULTANT MAX ELEMENT MOMENT (CONT)

$$\text{MOMENT @ } 28^{\circ} 28' = 172.8 \text{ IN-}\#$$

$$\text{MOMENT @ } 33^{\circ} 33' = 90.2 \text{ IN-}\#$$

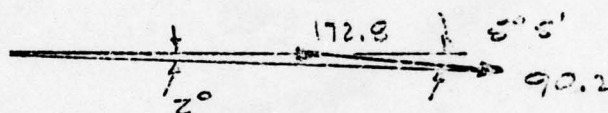

BY GRAPHICAL ANALYSIS
RESULTANT MOMENT IS

$$263 \text{ IN-}\# @ 30^{\circ}$$

5.8 FIND STRESSES IN ELEMENT TO BOOM CONNECTION

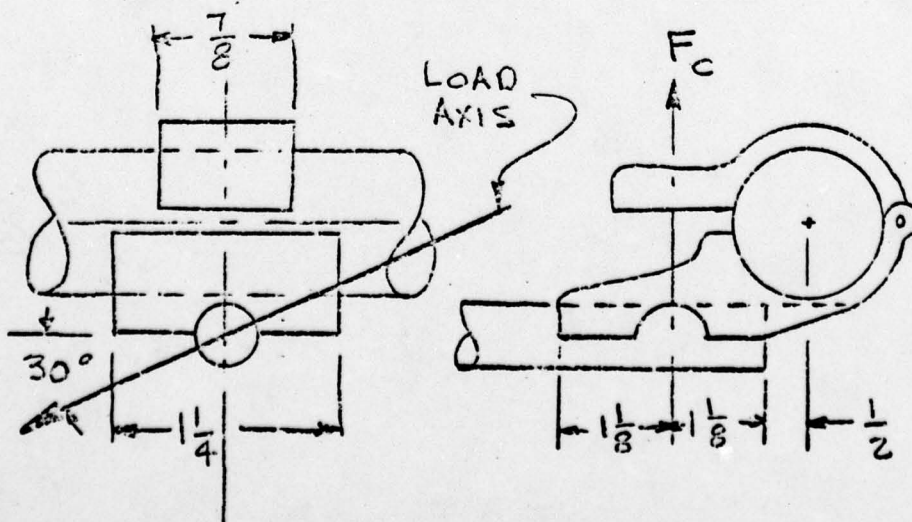

30-80 MHz TRANSPORTABLE LOG PERIODIC
ANTENNA STRESS ANALYSIS

8.8 FIND STRESS IN ELEMENT TO
BOOM CONNECTION (CONT.)

ELEMENT SECTION MODULUS
@ CLAMP BOLT

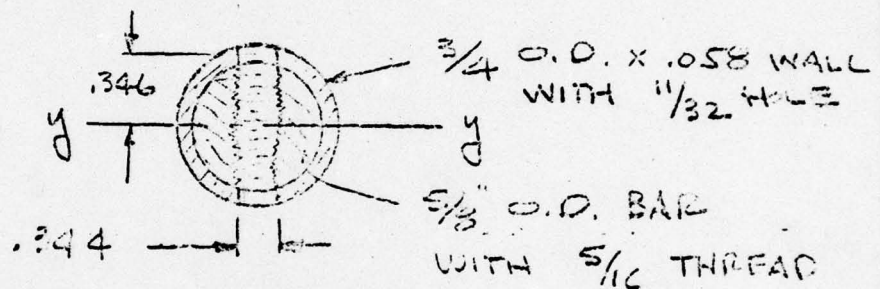

$$I_{yy} = I_{\frac{3}{4} \text{ TUBE}} + I_{\frac{5}{8} \text{ BAR}} - I_{\text{HOLE TUBE}} - I_{\text{HOLE ROD}}$$

I OF HOLE ON TUBE

$$I_{HT} = 2 \left[\frac{bh^3}{12} + Ad^2 \right]$$

$$= 2 \left[\frac{(.344)(.058)^3}{12} + (.344)(.058)(.246)^2 \right]$$

$$= 2 [.00000559 + 0.002389]$$

$$= 0.004788 \text{ IN}^4$$

BY: A. G. MEDINA

DOCUMENT NO. 3103-002

DATE: 20 APR. 1972

PAGE 13 OF 30

30-80 MHz TRANSPORTABLE LOG PERIODIC
ANTENNA STRESS ANALYSIS

8.8 FIND STRESS IN ELEMENT TO
COSH CONNECTION (CONT)

I OF THREADED SECTION

$$I = \frac{bh^3}{12}$$

$$= \frac{(0.285)(0.625)^3}{12} = 0.005798 \text{ in}^4$$

$$I_{yy} = 0.0076 + 0.007 - 0.004783 - 0.005798$$

$$I_{yy} = \underline{\underline{0.004014 \text{ in}^4}}$$

$$Z_{yy} @ .375$$

$$Z_{yy} = \frac{0.004014}{.375} = \underline{\underline{0.0107 \text{ in}^3}}$$

$$Z_{yy} @ .3125$$

$$Z_{yy} = \frac{0.004014}{.3125} = \underline{\underline{0.01284 \text{ in}^3}}$$

30-80 MHz TRANSPORTABLE LOG PERIODIC
ANTENNA STRESS ANALYSIS

3.3 FIND STRESS IN ELEMENT TO BOOM
CONNECTION (CONT)

DIRECTION OF MAX LOAD

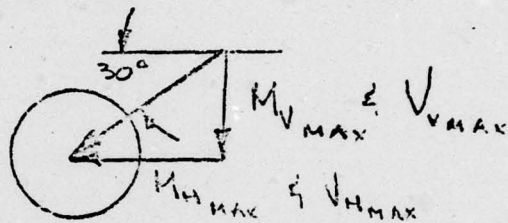

$$\text{MAX MOMENT} = 263 \text{ IN-}\#$$

SEE DAT. 9

MAX SHEAR

$$V_{\text{MAX}} = V_{R_{3/3}} + V_{R_{3/4}}$$

$$= (0.0461)(49.62) + (0.0695)(50.96)$$

$$= 2.287 + 3.542$$

$$= \underline{\underline{5.829 \#}}$$

FIND $M_{V\text{MAX}}$

$$M_{V\text{MAX}} = \sin 30^\circ 263$$

$$= \underline{\underline{131.5 \text{ IN-}\#}}$$

BY: A.G. MEDINA

DOCUMENT NO. E/DS-001

DATE: 24 APR 1977

PAGE 20 OF 30

30-80 MHz TRANSPORTABLE LOG PERIODIC
ANTENNA STRESS ANALYSIS8.8 FIND STRESS IN ELEMENT TO BOOM
CONNECTION (CONT)FIND V_{VMAX}

$$V_{VMAX} = \sin 30^\circ 5.829$$

$$= 2.915 \#$$

MAX MOMENT @ BOLT CONNECTION
SEE FIGURE SHT. 9.

$$M_{V_{BOLT}} = M_{VMAX} + 1.25(V_{VMAX})$$

$$= 131.5 + (1.25)(2.915)$$

$$= \underline{\underline{135.1 \text{ IN-}\#}}$$

ELEMENT STRESS @ HOLE DUE
TO VERTICAL SHEAR & MOMENT

$$S_{VMAX} = \frac{135.1}{0.0107} \text{ (FROM SHT. 11)}$$

$$S_{VMAX} = \underline{\underline{12,626 \text{ PSI}}}$$

ELECTROSPACE SYSTEMS, INC

BY: A.G. MEDINA

DOCUMENT NO. 5103

DATE: 24 APR 1971

PAGE 21 OF 31

30-80 MHz TRANSPORTABLE LOG PERIODIC
ANTENNA STRESS ANALYSIS8.8 FIND STRESS IN ELEMENT TO BOOM
CONNECTION (CONT)APPLYING STRESS CONCENTRATION
FACTOR OF

$$K = \frac{(1+V)(S-V)}{3+V}$$

WHERE: $V = 0.33$

(POSSIBLE RATIO)

$$K = \frac{(1.33)(4.67)}{3.33}$$

$$K = 1.865$$

MAX STRESS @ $\frac{3}{4}$ TUBE WITH
HOLE

$$\begin{aligned} S_{Y_{MAX}} &= 12,626 \times 1.865 \\ &= \underline{\underline{23,550 \text{ PSI}}} \end{aligned}$$

OK, UNDER ALLOWABLE 25,000 PSI

ELECTROSPACE SYSTEMS, INC

BY: A. G. MEDINA

DOCUMENT NO. 5ADP-000

DATE: 24 APR. 1972

PAGE 22 OF 30

30-80 MHz TRANSPORTABLE LOG PERIODIC
ANTENNA STRESS ANALYSIS

9.0 FIND MAX. BOOM LOADS

FROM OBSERVATION MAXIMUM BOOM
LOADS WILL OCCUR LOAD CONDITION "A"
CASE IV, OR LOAD CONDITION "B"
CASE VI.

9.1 BOOM LOADS UNDER CONDITION "A"
CASE IV

9.1.1 ELEMENT LOADS ON TO BOOM-VERTICAL

$$W_{e_i} = (W_e + W_{CLAMP ASSY}) + W_i$$

ELE NO	ELE. WT $W_e + W_{CLAMP}$	ELE. WT W_i	ELE. WT TOTAL W_{e_i}
1	2.284	5.1536	7.4376
2	2.0794	4.4684	6.4978
3	1.7986	3.8468	5.6454
4	1.5914	3.289	4.8804
5	1.408	2.795	4.203
6	1.2394	2.3408	3.5802
7	1.2598	1.9406	3.2004
8	1.1986	1.7646	2.9632
9	1.1424	1.6026	2.745
10	1.092	1.4574	2.5494
11	1.0466	1.3270	2.3736
12	.9832	1.1442	2.1274
13	.9692	1.1038	2.073
14	.9334	1.026	1.9394

30-30 MHz TRANSPORTABLE LOG PERIODIC ANTENNA STRESS ANALYSIS

9.1.2 BOOM WT WITH ICE

$$W_{T, \text{BOOM}} = 12.2488 \#$$

$$\text{BOOM LENGTH} = 19.045'$$

UNIT BOOM WT

$$W_{\text{BOOM}} = \frac{12.2488}{12 \times 19.045} = \underline{\underline{0.0536 \# / \text{IN}}}$$

BOTH BOOMS
NO ICE

$$W_{T_i, \text{BOOM}} = 20.86 \#$$

$$W_{i, \text{BOOM}} = \frac{20.86}{12 \times 19.045} = \underline{\underline{0.0913 \# / \text{IN}}}$$

EST. BOOMS -
1/4" ICE

9.1.3 ELEMENT LOADS ON BOOM - HORIZONTAL

FORCES DUE TO WIND ON ELEMENT

$$F_{CA} = 2P_A \left[(d_{ei \frac{3}{8}} \times l_{ei \frac{3}{8}}) + (d_{ei \frac{3}{4}} \times l_{ei \frac{3}{4}}) \right]$$

ELEMENT NO. 1

$$F_{e1A} = (2)(0.0463) \left[\overset{43.42}{(.875)(49.62)} + \overset{66.56}{(1.25)(53.25)} \right]$$

$$F_{e1A} = \underline{\underline{10.18 \#}}$$

ELECTROSPACE SYSTEMS, INC

BY: A.G. MEDINA

DOCUMENT NO. 3103-002

DATE: 24 APR. 1972

PAGE 24 OF 30

30-30 MHz TRANSPORTABLE LOG PERIODIC
ANTENNA STRESS ANALYSIS9.1.4 ELEMENT LOADS ON BOOM - HORIZONTAL
(CONT.)

ELE NO.	FORCE F _{o.A} #
1	10.18
2	8.99
3	7.91
4	6.93
5	6.07
6	5.23
7	4.64
8	4.21
9	3.80
10	3.44
11	3.12
12	2.67
13	2.56
14	2.31

UNIT WIND LOAD ON BOOM - HORIZONTAL

$$\begin{aligned}
 F_B &= 2 p d_i \\
 &= (2)(0.0463)(2) \\
 &= 0.1852 \text{ #/IN}
 \end{aligned}$$

BY: A.G. MEDINA

DOCUMENT NO. 3103-002

DATE: 25 APR 1977

PAGE 25 OF 30

20-30 MHz TRANSPORTABLE LOG PERIODIC ANTENNA STRESS ANALYSIS

9.2 FIND MAX MOMENT AT MOUNT
ELEMENT DUE TO LOADING
BY ELEMENTS NO. 1 THRU NO. 5

9.2.1 MOMENT DUE TO VERTICAL LOADS
REAR ANTENNA SECTION

$$M_{VA_{IV}} = (W_{e1})(l_1) + (W_{e2})(l_2) + (W_{e3})(l_3) \\ + (W_{e4})(l_4) + (W_{e5})(l_5) + \\ \frac{\sum W_{CLAMP} l_c + W_{BOOM} l_{BOOM}^2}{2}$$

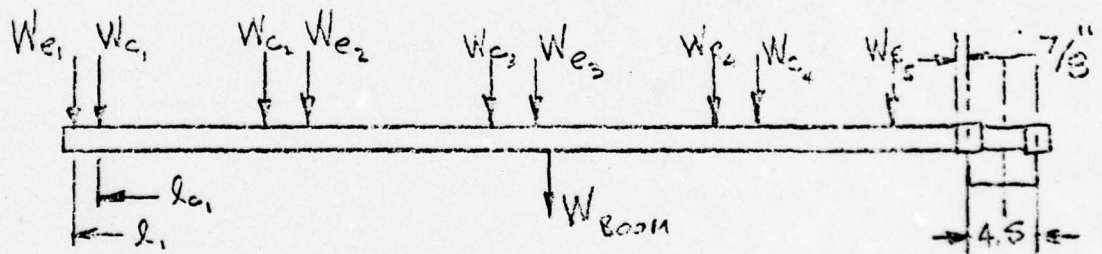

STATION	LOAD - W	DISTANCE - l IN	MOMENT - Wl IN-IN
W_{e1}	7.44	107.655	800.95
W_{c1}	1.12	105.905	118.61
W_{c2}	1.12	80.135	89.75
W_{e2}	6.50	77.187	501.72
W_{c3}	1.12	54.365	60.89
W_{e3}	5.65	49.755	281.12
W_{e4}	9.89	54.140	535.44
W_{c4}	4.88	25.071	122.35
W_{c5}	1.12	26.095	29.23
W_{e5}	4.20	2.847	11.96

$$\sum Wl = M_{VA_{IV}} = 2552 \quad \text{IN-IN}$$

AD-A076 319

ELECTROSPACE SYSTEMS INC RICHARDSON TEX
PRELIMINARY DESIGN AND VISUALIZATION PLAN. 30 TO 80 MHX VHF BRO--ETC(U)
APR 72 DAAB07-72-C-0137
ER-72-10 NL

UNCLASSIFIED

2 OF 2
ADA
076319



END
DATE
FILMED
11 -79
DDC

ELECTROSPACE SYSTEMS, INC

BY: A. G. MEDINA

DOCUMENT NO. E/03-002

DATE: 20 APR 1977

PAGE 26 OF 30

30-30 MHz TRANSPORTABLE LOG PERIODIC
ANTENNA STRESS ANALYSIS9.2.2 MOMENT DUE TO - HORIZONTAL LOADS
REAR ANTENNA SECTION

$$M_{HA_{III}_R} = (F_{EA_1} l_1) + (F_{EA_2} l_2) + (F_{EA_3} l_3) + (F_B l_B) + (F_{EA_4} l_4) + (F_{EA_5} l_5)$$

STATION	FORCE - F #	DISTANCE - L IN	MOMENT - FL IN-#
F _{E1}	10.18	107.655	1095.93
F _{E2}	3.99	77.137	693.91
F _{E3}	7.91	49.755	393.56
F _B	20.05	54.140	1085.51
F _{E4}	6.93	25.071	173.74
F _{E5}	6.07	2.897	17.28

$$\Sigma FL = M_{HA_{III}_R} = \underline{\underline{3460 \text{ IN-}\#}}$$

9.2.3 MOMENT DUE TO - VERTICAL LOADS
FRONT ANTENNA SECTION

$$M_{VA_{III}_F} = \Sigma W_e l_e + \Sigma W_c l_c + W_B l_B + W_{COAX} \frac{l_{COAX}}{2} + W_{TRANS} l_{TRANS}$$

BY: A.G. MEDINA
DATE: 25 APR 1972DOCUMENT NO. 3703-0012
PAGE 27 OF 5030-30 MHz TRANSPORTABLE LOG-PERIODIC
ANTENNA STRESS ANALYSIS9.2.2 MOMENT DUE TO VERTICAL LOADS
FRONT ANTENNA SECTION (CONT.)

STATION	LOAD - W #	DISTANCE - L IN	MOMENT - WL IN-#
W ₁₄	1.97	113.327	22.34
W _{e14}	1.94	113.327	219.97
W _{e13}	2.07	104.732	216.90
W _{e12}	2.13	95.719	202.92
W _{e9}	1.12	81.175	90.92
W _{e11}	2.37	89.587	200.47
W _{e10}	2.55	72.779	185.59
W _{e9}	2.75	59.663	164.07
W _{BF}	10.41	57.01	593.47
W _{COAR}	.98	57.01	55.87
W _{e8}	1.12	49.865	55.85
W _{e8}	2.96	45.033	133.45
W _{e7}	3.20	29.895	92.46
W _{e7}	1.12	24.325	27.26
W _{e6}	3.58	10.895	39.00

$$\Sigma WL = M_{NA \square F} = 2300 \text{ IN-#}$$

ELECTROSPACE SYSTEMS, INC

BY: A. G. MEDINA

DOCUMENT NO. 3105-002

DATE: 25 APR. 1972

PAGE 23 OF 30

30-80 MHz TRANSPORTABLE LOG PERIODIC
ANTENNA STRESS ANALYSIS9.2.4 MOMENT DUE TO HORIZONTAL WIND
FORCES - FRONT ANTENNA SECTION

STATION	FORCE - F	DISTANCE - L	MOMENT - FL
F_{e14}	2.31	113.237	261.92
F_{e13}	2.56	104.733	263.24
F_{e12}	2.67	95.219	254.23
F_{e11}	3.12	84.537	263.91
F_{e10}	3.44	72.779	250.36
F_{e9}	3.80	59.663	226.72
F_B	21.12	57.01	1204.05
F_{e8}	4.21	45.033	189.80
F_{e7}	4.64	28.895	134.07
F_{e6}	5.23	10.895	57.53

 3111 1A-H

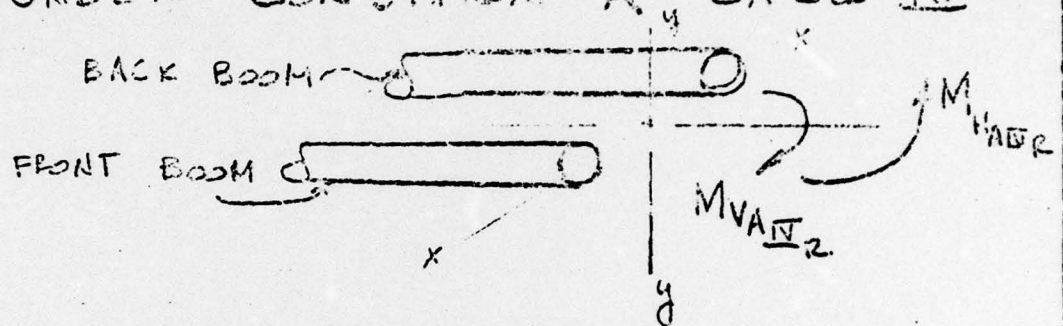
30-35 MHz TRANSPORTABLE LOG PERIODIC
ANTENNA STRESS ANALYSIS9.3 BOOM MAX. STRESSES
UNDER CONDITION "A" CASE IV

MAX. COMPRESSIVE STRESS WILL
BE SEEN IN BACK BOOM DUE
TO BENDING BY $M_{VAI\text{V}}$ MOMENT
AND FORCE DUE TO MOMENT
 $M_{HAI\text{V}}$

COMPRESSIVE FORCE

$$F_{Hc} = \frac{M_{HAI\text{V}}}{4.125} = \frac{3460}{4.125}$$

$$F_{Hc} = \underline{\underline{839 \#}}$$

STRESS

$$S_{MAXA\text{IV}} = \frac{M_{VAI\text{V}}}{Z_{BOOMS}} + \frac{F_{Hc}}{A_{BOOM}}$$

30-80 MHz TRANSPORTABLE LOG PERIODIC
ANTENNA STRESS ANALYSIS

9.2 BOOM MAX STRESS (CONT)

FIND Z_{BOOM} FROM DATA HANDBOOK

$$Z = 0.1669 \times 2 = \underline{\underline{0.3338 \text{ IN}^2}}$$

$$\begin{aligned} A_{BOOM} &= \pi \left[(R_o^2) - (R_i^2) \right] \\ &= 3.1416 \left[\left(\frac{1.50}{2} \right)^2 - \left(\frac{1.384}{2} \right)^2 \right] \\ &= \underline{\underline{0.2628 \text{ IN}^2}} \end{aligned}$$

$$\begin{aligned} S_{MAX. \text{AV}} &= \frac{2552}{0.3338} + \frac{839}{.2628} \\ &= 7645 + 3193 \\ &= \underline{\underline{10,838 \text{ PSI}}} \end{aligned}$$

O.K. UNDER ALLOWABLE