

AD-A076 383

ELECTRO NUCLEAR SYSTEMS CORP BETHESDA M
PHASE CALIBRATION OF ACOUSTIC-ELECTRONIC SYSTEMS, (U)
JUL 62 B T JOHNSON , E M FITZGERALD

F/G 17/1

NONR-3452(00)

UNCLASSIFIED

NL

| OF |

AD
A076383

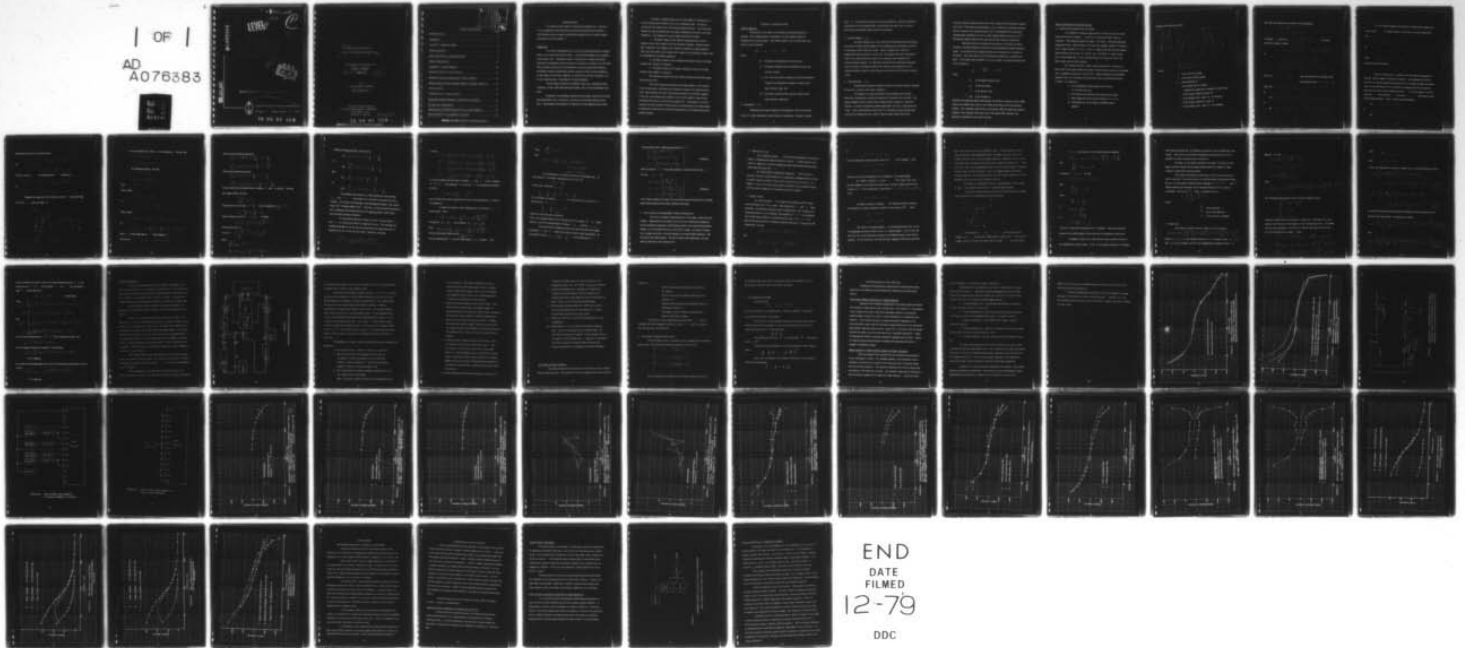

END
DATE
FILMED
12-79
DDC

MT 502 2477

H. J. Raniatt

File

P

LEVEL

AD A 076383



NB. 385-423
com 411

DDC
RECEIVED
NOV 9 1979
E

DDC FILE COPY

APPROVED FOR PUBLIC RELEASE; DISTRIBUTION UNLIMITED



ELECTRO NUCLEAR SYSTEMS CORPORATION

8001 norfolk • bethesda 14, maryland • 654-6133

78 08 07 23 3

6 PHASE CALIBRATION OF
ACOUSTIC-ELECTRONIC SYSTEMS

AUTEC Signal Processing Project

15 Nonr 3452(00) ✓
11 23 July 23, 1962 1262

10
Prepared by B. T. Johnson
and E. M. Fitzgerald

✓ Technical Research Division
Electro Nuclear Systems Corporation
8001 Norfolk Avenue
Bethesda 14, Maryland

124 550

78 08 07 23 3 LB

Approved/Checked	<input checked="" type="checkbox"/>
Name	Charles
Division	ELC IAB
Unnumbered	
Justification	
By	
Distribution/	
Availability Codes	
Dist.	Avail and/or special
	A

TABLE OF CONTENTS

	Page
INTRODUCTION	1
<u>Background</u>	1
GENERAL CONSIDERATIONS	3
<u>General Approach</u>	3
<u>Phase Calibration of Electrical Systems</u>	6
<u>Phase Measurements</u>	25
<u>Calculation of Phase Relations</u>	29
PRESENTATION OF TEST RESULTS	32
<u>Preliminary Phase Measurement of Typical Systems</u>	32
<u>Phase Response of Instrumentation System and Tape Transports</u>	32
CONCLUSIONS	56
ANTICIPATED FUTURE EFFORT	57
<u>Laboratory Phase Calibration of Hydrophone Electronics</u>	57
<u>On-Site Phase Calibrations</u>	58
<u>Tape-Recorder Calibration using Phase-Locked Oscillators</u>	58
<u>Recommended Time Coordination Procedure</u>	60

APPROVED FOR PUBLIC RELEASE; DISTRIBUTION UNLIMITED

INTRODUCTION

The object of this report is to present the approach to, mechanics of, and progress to date of performing phase calibrations of the measurement systems used to acquire radiated noise signals for the "acoustic signal processing research program." *→ to page 56*

Background

For better understanding of the method of establishing these relationships, let us review the project briefly. Two listening stations were equipped and manned at sea. Waterborne sound, emitting from a single source, was detected by hydrophones of both measurement stations, amplified, and recorded. The recorded signals are to be subjected to a type of analysis that requires knowledge of phase relationships between signals arriving at all hydrophones on both ships at any instant. Signals are recorded on two tape transports, one on each listening ship. Tape speed is 30 ips throughout.

The two ships involved are MONOB, where four hydrophones were monitored, and the USS LITTLEHALES (AGSS), where three hydrophones were used.

In general, the quantities measured by the phase calibration technique described herein will, in each case, be the sum of the phase shift and delay time. This quantity will hereafter be referred to as the apparent phase shift.

Consider a magnetic tape record of data taken simultaneously from several hydrophones located on each of two listening ships. The data is necessarily recorded on two multi-channel tape transports. Time reference signals are also simultaneously recorded on additional channels of both tape transports. The calibration of such a tape record then involves:

1. The determination of the relative tape positions of a given instant in time, with respect to the time reference signals. These positions will, in general, vary slightly from channel to channel on a tape transport. Thus, the time-shift of each channel with respect to the reference channel must be established on both tape transports.

2. The determination of the amplitude responses of each of the data channels with respect to frequency.

3. The determination of the phase responses of each of the data channels with respect to frequency.

The following criterion has been used to differentiate between phase shift and time shift:

Time shift changes the position of an input waveform with respect to the timing signal, and phase shift changes the shape of the input waveform. Thus, determination (1) above will produce quantities that should be applied in the time coordination and a quantity of time shift related to interchannel characteristics which is referred to as delay time. This delay time and the results of (2) and (3) above would be used in the processing of the data signals to effectively reduce them to electrical equivalents of the original waterborne acoustic signals.

GENERAL CONSIDERATIONS

General Approach

The problem is to determine the phase relationship between an acoustic wave impinging upon a hydrophone and the resulting signal as reproduced from tape storage. This determination may be broken down into several parts as follows:

$$\Phi_I = \phi_H + \phi_E + \phi_T$$

where

Φ_I = the phase relationship to be determined,

ϕ_H = the phase response of the hydrophone to incoming acoustic signals,

ϕ_E = the cumulative phase response of the instrumentation between the hydrophone transducer output and the tape recorder input, and

ϕ_T = the phase response of the specific channel of the tape recorder-reproducer.

1. Hydrophone (ϕ_H)

Measurement of phase response of hydrophones will be carried out by the U. S. Navy Underwater Sound Reference Laboratory, Orlando, Florida.

Both CW and impulse techniques are being considered. Specific calibration procedures will be developed after consideration with other team members and with the Underwater Sound Reference Laboratory.

2. Instrumentation (ϕ_E)

For this measurement, sine waves were inserted into the hydrophone calibration circuits and the outputs of the subsequent instrumentation recorded on tape along with a reference signal. This is repeated for a series of frequencies over the spectrum of interest. The signals were then reproduced and the time delays and phase shifts were measured with respect to the reference signal channel. By separate measurements of the phase responses and time delays of the tape transport data channels with respect to an FM reference channel, tape recorder effects are removed from the above measurements.

3. Tape Recorder (ϕ_r)

Measurement of phase responses and the time delays between channels of each tape recorder were made as follows:

The output of an audio oscillator was paralleled into all inputs. Successive frequencies covering the spectrum of interest were recorded. The phase response and time delays were measured with respect to a reference channel. In order to estimate absolute phase shift, two basic assumptions are made. First, that the phase shift of the FM recording channels approximate zero for low frequencies and, second, that the phase shift of the direct

recording channels approximates zero at the midpoint of its amplitude response pass band. With these two assumptions, and a measurement of phase relations between channels, the measured values can be extrapolated to an estimated absolute phase response curve for a given channel within an accuracy of $\pm 5^\circ$. The apparent phase shift for each data channel was measured separately.

Since the record and reproduce electronics are similar for these channels, the phase difference should be small throughout the useful frequency range. It was found that the apparent phase shift increased as a function of frequency. The linear portion of this increase is related to a constant time delay. If the phase shift is totally due to a time delay, the apparent phase shift may be written as

$$\phi = \frac{\Delta t}{T} = f \Delta t$$

where

ϕ is the apparent phase shift,

Δt is the time delay,

T is the period, and,

$f = \frac{1}{T}$ is the frequency.

Therefore the apparent phase shift between the reference channel and each data channel was plotted and a linear curve fitted to the data by the least squares method. The calculated slope of this curve equals Δt the delay time between channels. The residuals from this curve is the phase shift related to the electrical impedance of recording channels.

Phase Calibration of Electrical Systems

a. Measurement Requirements and Theory

It is required to measure phase shifts of signals of varying amplitudes but the same frequency. To this end, a Beckman EPUT Meter is employed. This instrument has two inputs, "B" and "A", both with adjustable triggering levels. These levels can be set at any voltage, positive or negative, over a range of about -1 v to + 1 v. The "B" input is used for all single signal input functions such as per. "B", EPUT, etc., while the "A" input is used only in conjunction with "B" for measurements such as per. B-A (time the stop trigger lags the start trigger).

The requirements for a phase measurement are to measure the phase shift of one signal relative to another with as high an accuracy as possible over a frequency range from 5 cps to 10 kc. Before defining the operational requirements, it is necessary to examine the actual measurement process in detail. It is assumed:

- a. The amplitudes of both signals can be varied
at will up to 20 v p-p,
- b. One signal is not inverted with respect to the other,
- c. Both triggering levels are set close to 0 v (< 1 v),
- d. Both inputs are set to trigger on positive going
signals.

Consider the following signals:

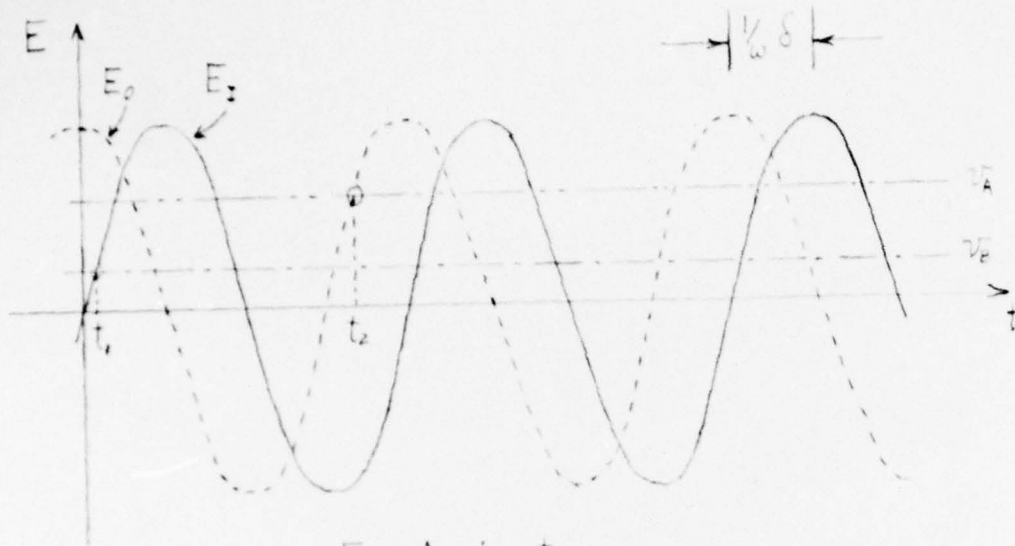

$$E_I = A_I \sin \omega t$$

$$E_O = A_O \sin(\omega t + \delta)$$

where

E_I is the reference signal

E_O is the phase-shifted signal

A_I, A_O the amplitudes of E_I, E_O

δ is the phase shift in radians

(positive for phase lead, negative for phase lag)

V_B is the trigger voltage of input "B"

t_1 is the trigger time, input "B", for starting

V_A is the trigger voltage for input "A"

t_2 is the trigger time, input "A", for stopping

The start and stop times are defined by the equations:

$$v_B = A_I \sin \omega t_1$$

$$v_A = A_0 \sin(\omega t_2 + \delta)$$

To obtain δ in terms of $v_A, v_B, A_I, A_0, t_2, t_1$ we make use of the relation, letting $X = \sin Y$:

$$Y = (-1)^n \sin^{-1} X + n\pi, \quad -\pi/2 \leq \sin^{-1} X \leq \pi/2$$

or

$$Y = \sin^{-1} X, \quad -\pi/2 \leq \sin^{-1} X \leq \pi/2$$

$$Y = \pi - \sin^{-1} X, \quad \pi/2 \leq Y \leq 3\pi/2$$

$$Y = 2\pi + \sin^{-1} X, \quad 3\pi/2 \leq Y \leq 5\pi/2, \text{ etc.}$$

Then, (1) $\omega t_1 = \sin^{-1} \frac{v_B}{A_I}$ since the start time is always in the first quarter cycle ($\omega t_1 < \pi/2$).

Also, (2) $\omega t_2 + \delta = \sin^{-1} \frac{v_A}{A_0}$, $-\pi/2 \leq \omega t_2 + \delta \leq \pi/2$

or

$$(3) \quad \omega t_2 + \delta = \pi - \sin^{-1} \frac{v_A}{A_0}, \quad \pi/2 \leq \omega t_2 + \delta \leq 3\pi/2$$

or

$$(4) \quad \omega t_2 + \delta = 2\pi + \sin^{-1} \frac{v_A}{A_0}, \quad 3\pi/2 \leq \omega t_2 + \delta \leq 5\pi/2.$$

We may discard equation (3) because it implies that the stop time occurs when E_0 is negative-going. To see this, we solve equation (3) for v_A .

$$v_A = A_0 \sin\{\pi - (\omega t_2 + \delta)\}$$

or

$$v_A = A_0 \sin(\omega t_2 + \delta)$$

Then $\frac{dv_A}{dt_2} = A_0 \omega \cos(\omega t_2 + \delta)$

but for the second equation

$$\pi/2 \leq \omega t_2 + \delta \leq 3\pi/2$$

Thus, the cosine term is negative over the region the equation is defined, and the slope of the signal is negative. For equations (2) and (4), however, the signal is positive-going and thus can trigger the stop mechanism. Also, we cannot discard one or the other of equations (2) and (4) using the intervals over which each is defined because δ is as yet unknown, and for any given ωt_2 there exists a δ such that $(\omega t_2 + \delta)$ falls within either of the intervals shown. Thus, we have two possibilities:

$$(5) \quad \omega t_2 + \delta = \sin^{-1} \frac{v_A}{A_0}$$

or

$$(6) \quad \omega t_2 + \delta = 2\pi + \sin^{-1} \frac{v_A}{A_0}$$

Subtracting (1) from (5) and (6) we have

$$\omega(t_2 - t_1) + \delta = \sin^{-1} \frac{V_A}{A_0} - \sin^{-1} \frac{V_B}{A_I}$$

or

$$\omega(t_2 - t_1) + \delta = 2\pi + \sin^{-1} \frac{V_A}{A_0} - \sin^{-1} \frac{V_B}{A_I}$$

Whence, calling δ_{I-0} the phase lead of E_0 relative to E_I

$$\delta_{I-0}^{(1)} = \sin^{-1} \frac{V_A}{A_0} - \sin^{-1} \frac{V_B}{A_I} - \omega(t_2 - t_1)$$

or

$$\delta_{I-0}^{(2)} = \sin^{-1} \frac{V_A}{A_0} - \sin^{-1} \frac{V_B}{A_I} + 2\pi - \omega(t_2 - t_1).$$

Suppose the inputs are now reversed, so that E_0 goes into input

"B" while E_I goes into input "A".

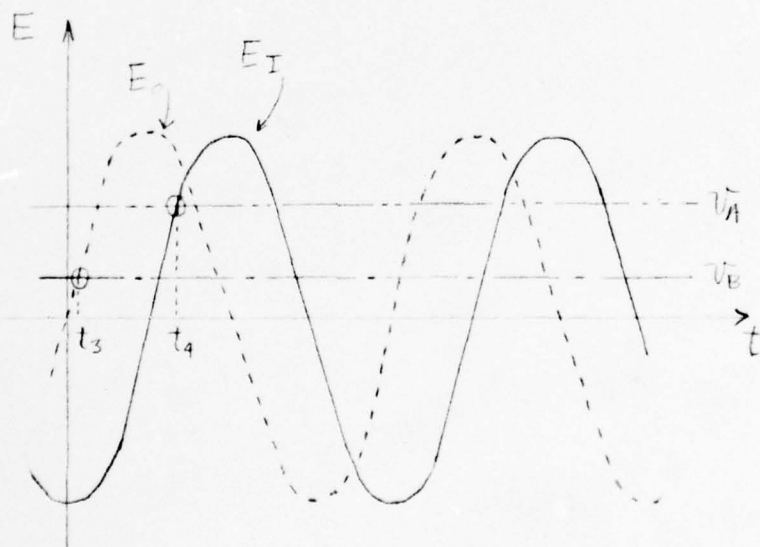

t_3 is now the start time, while t_4 is the stop time. We now have

$$E_0 = A_0 \sin \omega t$$

$$E_1 = A_1 \sin(\omega t - \delta)$$

Proceeding as before, we have

$$v_B = A_0 \sin \omega t_3$$

$$v_A = A_1 \sin(\omega t_4 - \delta)$$

and
$$\omega t_3 = \sin^{-1} \frac{v_B}{A_0}$$

Also, either

$$\omega t_4 - \delta = \sin^{-1} \frac{v_A}{A_1}$$

or

$$\omega t_4 - \delta = 2\pi + \sin^{-1} \frac{v_A}{A_1}$$

Thus, either

$$\delta_{0-1}^{(1)} = -\sin^{-1} \frac{v_A}{A_1} + \sin^{-1} \frac{v_B}{A_0} + \omega(t_4 - t_3)$$

or

$$\delta_{0-1}^{(2)} = -\sin^{-1} \frac{v_A}{A_1} + \sin^{-1} \frac{v_B}{A_0} - 2\pi + \omega(t_4 - t_3)$$

where δ_{0-1} is the phase lag of E_1 with respect to E_0 .

We now let $(t_2 - t_1) = T_1$, $(t_4 - t_3) = T_2$

Then the first measurement gives

$$\delta_{I-0}^{(1)} = -\omega T_1 + \sin^{-1} \frac{v_A}{A_0} - \sin^{-1} \frac{v_B}{A_I}$$

$$\delta_{I-0}^{(2)} = 2\pi - \omega T_1 + \sin^{-1} \frac{v_A}{A_0} - \sin^{-1} \frac{v_B}{A_I}$$

The second measurement gives

$$\delta_{0-I}^{(1)} = \omega T_2 + \sin^{-1} \frac{v_B}{A_0} - \sin^{-1} \frac{v_A}{A_I}$$

$$\delta_{0-I}^{(2)} = -2\pi + \omega T_2 + \sin^{-1} \frac{v_B}{A_0} - \sin^{-1} \frac{v_A}{A_I}$$

We now make the assumption that by making A_0 and A_I big and zeroing the trigger levels, we have

$$\frac{v_{A,B}}{A_{I,0}} < 0.1$$

Then all terms of the type $\sin^{-1} \frac{v}{A}$ may be replaced by $\frac{v}{A}$; i.e.,

$$\sin^{-1} \frac{v_A}{A_I} \rightarrow \frac{v_A}{A_I}, \text{ etc.}$$

with a maximum error of $\sim 0.2\%$. In detail,

$$\sin^{-1} \frac{v}{A} = \frac{v}{A} + \frac{1}{6} \left(\frac{v}{A}\right)^3 + \dots$$

The percent error is

$$\% \text{ error} = \frac{\sin^{-1} \frac{v}{A} - \frac{v}{A}}{\frac{v}{A}} = \frac{1}{6} \left(\frac{v}{A}\right)^2$$

Since

$$\left(\frac{v}{A}\right)_{\max} = 0.1$$

$$(\% \text{ error})_{\max} = \frac{1}{6} (0.1)^2 \cong 0.2\%$$

Making this approximation, we then have

$$(7) \quad \delta_{I-0}^{(1)} = -\omega T_1 + \frac{V_A}{A_0} - \frac{V_B}{A_I}$$

or

$$(8) \quad \delta_{I-0}^{(2)} = 2\pi - \omega T_1 + \frac{V_A}{A_0} - \frac{V_B}{A_I}$$

and

$$(9) \quad \delta_{0-I}^{(1)} = \omega T_2 + \frac{V_B}{A_0} - \frac{V_A}{A_I}$$

or

$$(10) \quad \delta_{0-I}^{(2)} = -2\pi + \omega T_2 + \frac{V_B}{A_0} - \frac{V_A}{A_I}$$

The question now arises as to which equation to use to obtain δ_{I-0} and δ_{0-I} . The answer is to be found in the operation of the counter. The instrument obviously cannot distinguish between, say, phase lags of 90° or phase leads of 270° . Therefore, it will be assumed that those set of equations will be used that give the minimum phase angle unless previous data indicates otherwise.

We now wish to take the average of the two measurements δ_{I-0} and δ_{0-I} to minimize the effect of systematic errors. We must take all possible averages of the two measurements since we cannot say which of equations (7), (8), or (9), (10) are valid. Therefore, denoting

$$\bar{\delta}^{m,n} = \frac{1}{2} \left[\delta_{0-I}^{(m)} + \delta_{I-0}^{(n)} \right],$$

we have

$$\bar{\delta}^{1,1} = \frac{1}{2} \left[\omega (T_2 - T_1) + (v_B + v_A) \left(\frac{1}{A_0} - \frac{1}{A_I} \right) \right]$$

$$\bar{\delta}^{1,2} = \frac{1}{2} \left[2\pi + \omega (T_2 - T_1) + (v_B + v_A) \left(\frac{1}{A_0} - \frac{1}{A_I} \right) \right]$$

$$\bar{\delta}^{2,1} = \frac{1}{2} \left[-2\pi + \omega (T_2 - T_1) + (v_B + v_A) \left(\frac{1}{A_0} - \frac{1}{A_I} \right) \right]$$

$$\bar{\delta}^{2,2} = \frac{1}{2} \left[\omega (T_2 - T_1) + (v_B + v_A) \left(\frac{1}{A_0} - \frac{1}{A_I} \right) \right].$$

It can immediately be seen that by making v_A and v_B small compared to A_0, A_I ; and adjusting A_0 as close to A_I in magnitude as possible, the term

$$(v_A + v_B) \left(\frac{1}{A_0} - \frac{1}{A_I} \right)$$

can be made very small compared to the rest of the expressions. We therefore neglect it.

To obtain an estimate of the resulting error, we assume $v_A = v_B$ (worst case). Then

$$(v_A + v_B) \left(\frac{1}{A_0} - \frac{1}{A_I} \right) = 2v_A \left(\frac{A_I - A_0}{A_0 A_I} \right)$$

We assume $A_0 \approx A_I$. Let us define $A_I - A_0 \equiv \Delta A$

$$\text{Then } (v_A + v_B) \left(\frac{1}{A_0} - \frac{1}{A_I} \right) = 2 \left(\frac{v_A}{A_I} \right) \cdot \left(\frac{\Delta A}{A_I} \right)$$

We have previously assumed that $\left(\frac{v_A}{A_I} \right) < 0.1$.

We now estimate that A_0 can be made equal to A_I to within 2 db.

Thus, $\frac{\Delta A}{A_I} \sim 0.26$.

Then

$$\begin{aligned} (v_A + v_B) \left(\frac{1}{A_0} - \frac{1}{A_I} \right) &\sim 2(0.1)(0.26) \\ &\approx 0.052 \text{ radians} \\ &\approx 3.0^\circ \text{ maximum.} \end{aligned}$$

It is interesting to compare this with the unaveraged case. In that instance, we would be neglecting terms of the form

$$\frac{v_B}{A_0} - \frac{v_A}{A_I}$$

In this case, assuming $A_0 \approx A_I$

$$\frac{v_B}{A_0} - \frac{v_A}{A_I} \approx \frac{1}{A_I} (v_B - v_A) = \frac{\Delta v}{A_I}$$

The uncertainty in setting $v_A = v_B$ (to minimize error) is about 0.2 v, and assuming $A_I \approx 2.0$ v

$$\begin{aligned} \frac{v_B}{A_0} - \frac{v_A}{A_I} &\approx 0.1 \text{ radians} \\ &\approx 5.7^\circ \end{aligned}$$

under the most favorable conditions.

Thus, the averaging allows us to minimize error by making $A_0 = A_I$ rather than the much more difficult task of making $A_0 \approx A_I$ and then $v_A = v_B$.

Assuming that the triggering levels have been zeroed and the input amplitudes A_0 and A_I made as big and as close to equal as possible, we can neglect the term $(v_A + v_B) \left(\frac{1}{A_0} - \frac{1}{A_I} \right)$ in the equations for \bar{v} .

We then obtain three independent equations for $\bar{\delta}$:

$$\left. \begin{aligned} \bar{\delta} &= \frac{1}{2} [\omega(\tau_2 - \tau_1)] \\ \bar{\delta} &= \frac{1}{2} [2\pi + \omega(\tau_2 - \tau_1)] \\ \bar{\delta} &= \frac{1}{2} [-2\pi + \omega(\tau_2 - \tau_1)] \end{aligned} \right\} \text{(radians)}$$

Since the period T of the input signals is measured rather than ω ,

we have $\omega = \frac{2\pi}{T}$

$$\left. \begin{aligned} \bar{\delta} &= (180^\circ) \left[\frac{(\tau_2 - \tau_1)}{T} \right] \\ \bar{\delta} &= (180^\circ) \left[\frac{T + (\tau_2 - \tau_1)}{T} \right] \\ \bar{\delta} &= (180^\circ) \left[\frac{-T + (\tau_2 - \tau_1)}{T} \right] \end{aligned} \right\} \text{(degrees)}$$

Any of these equations is valid; the one should be used that gives the smallest phase angle unless previous data indicates otherwise.

b. Error Sources and Magnitudes in Phase Measurement

The errors in phase measurement are of two types, systematic and random. Systematic errors arise from (a) errors in setting the triggering levels and signal amplitudes, and (b) phase shifts in the measuring equipment. Random errors include (a) errors in the EPUT counter, (b) random changes in the triggering levels, (c) small changes in the input signal frequency, and (d) noise on the input signals. We will consider these separately, and then make an estimate of the overall error.

1. Systematic Errors

(a) Triggering Levels - This has been discussed in the section under "a. Measurement Requirements and Theory." It was found that the maximum phase error with the triggering levels zeroed and the input amplitudes equal and large was $\Delta \bar{\delta} \sim 3^\circ$

(b) Phase Shifts in Measuring Equipment - This is hard to estimate, but with careful selection of components, the phase shifts over the frequency range of interest (5 cps to 10 kc) can be cut to a minimum. In addition, it is recommended that a phase calibration of the measuring equipment be made to supply any corrections that may be needed.

2. Random Errors

(a) EPUT Counter - The counter in the Beckman EPUT Meter has an intrinsic error of ± 1 count. This affects both T and T_{21} measurements. It should be noted here that for signals up to 1 kc, the period is measured, while from 1 kc upwards, the frequency (E/UT) is measured. The counter has provision to measure (period $\times 10$) or ($E/UT \times 10$) so that the maximum period or frequency measurement error is one part in 10^4 . Analytically, we have

$$\Delta T = 10^{-4} \text{ msec. } (F \leq 1 \text{ kc})$$

and

$$\Delta F = 10^{-1} \text{ cps } (F \geq 1 \text{ kc})$$

or

$$\Delta T = T^2 \times 10^{-1} \text{ sec.}$$

For time difference measurements, there is no $\times 10$ multiplier. Thus

$$\Delta T_1 = 10^{-3} \text{ msec}$$

$$\Delta T_2 = 10^{-3} \text{ msec.}$$

These errors are thus dependent on the frequency of the input signals.

(b) Random Changes in V_A and V_B - The "start" and "stop" Schmitt triggers in the Beckman counter have a random triggering level shift of about 0.1 v. This should have no real effect if $A_0 = A_I$ and $V_{A,B} \ll A_{0,I}$. Thus,

$$\Delta V_A = \Delta V_B = 0.1 V$$

(c) Signal Frequency Changes - The Hewlett-Packard oscillator to be used has a random frequency variation of two parts in 10^4 . Thus

$$\Delta F = 10^{-4} F$$

or

$$\Delta T = 10^{-4} T$$

(d) Noise on the Input Signals - It is anticipated that there may be a considerable amount of noise on the phase-shifted signal. Some of this will be in the form of 60-cycle pick-up and some broadband random noise will be present. To minimize this, two RM-122 high-impedance Tektronix amplifiers

have been selected to use for amplitude control. These amplifiers have a high and low pass filter (adjustable) which can filter out most of the noise. If these filters are set so that the signal frequency of interest is in the center of the pass band, the phase shift through each amplifier should be zero. Even if it is not, since both signals pass through the same type amplifier, the phase shifts for each should be the same; thus, the relative phase shift should remain unchanged. It is thus desirable to perform a phase calibration on both amplifiers with various cut-off frequencies set in.

It is extremely difficult to estimate, quantitatively, the error due to noise. The following is an order-of-magnitude approximation.

We assume that the greatest portion of the noise lies at frequencies much higher (say ten times) than the signal frequency.

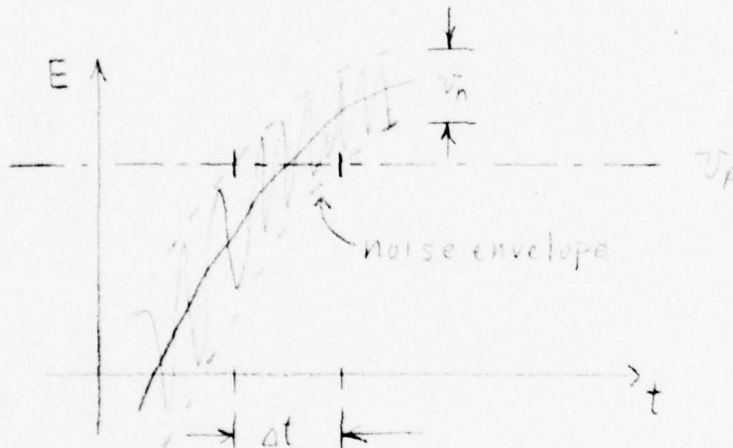

If the signal is $E_0 = A_0 \sin \omega t$, Δt is the uncertainty in trigger time, V_n is the noise voltage (peak to peak), and V_A the triggering voltage, then we consider the noise to lie in a band V_n as shown above.

If v_A is set near zero the following equation applies:

$$\text{slope of noise envelope} = \left. \frac{dE_0}{dt} \right|_{E=0} \cong \frac{v_n}{\Delta t}$$

but

$$\frac{dE_0}{dt} = Aw \cos wt$$

We assume $v_A \cong 0$, so that

$$\sin wt \cong 0, \cos wt \cong 1$$

and

$$\left. \frac{dE_0}{dt} \right|_{E=0} = Aw$$

Then

$$Aw \cong \frac{v_n}{\Delta t}$$

or

$$\Delta t \cong \frac{v_n}{Aw}$$

or

$$\cong \frac{T \cdot v_n}{2\pi A}$$

$$2\pi \left(\frac{\Delta t}{T} \right) \cong \frac{v_n}{A}$$

The term on the left is the phase error in radians. Thus we see that the phase error is about equal to the reciprocal of the signal-to-noise ratio.

In addition to the above, there are two other sources of noise to be considered in certain cases. First, for the phase calibration of a system

with hydrophone attached, low frequency acoustical noise is picked up by the system. This can be minimized by isolating the hydrophones as much as possible from the acoustical noise environment.

Secondly, for the phase calibration of a system in which both the phase reference signal and the phase-shifted signal are outputs of a tape transport, flutter and wow are present.

The random fluctuations in phase due to these noise sources are hard to estimate. In the case where it is felt that these sources predominate, the error is estimated by taking several readings of T (or F), T_1 , and T_2 . These readings are averaged, and the standard deviation of the mean is calculated. The error in T_2 , (say), would then become

$$\pm \left[\frac{\overline{T_2^2} - \overline{T_2}^2}{N-1} \right]^{1/2}$$

where

$\overline{T_2}$ is the averaged T_2
 $\overline{T_2^2}$ is the mean squared T_2
 N is the number of readings.

3. Total Error

The total error due to several random errors is given by

$$\Delta F(x, y, z) = \left[\left(\frac{\partial F}{\partial x} \right)^2 (\Delta x)^2 + \left(\frac{\partial F}{\partial y} \right)^2 (\Delta y)^2 + \left(\frac{\partial F}{\partial z} \right)^2 (\Delta z)^2 \right]^{1/2},$$

where $F(x, y, z)$ is the variable whose error ΔF we wish to find. Δx , Δy , and Δz are the random errors in the independent variables on which F

depends. We have

$$\bar{\delta} = \pi \left[\frac{T + (T_2 - T_1)}{T} \right]$$

$$\bar{\delta} = \pi \left[\frac{-T + (T_2 - T_1)}{T} \right]$$

$$\bar{\delta} = \pi \left[\frac{(T_2 - T_1)}{T} \right]$$

Thus

$$\Delta \bar{\delta}(T, T_1, T_2) = \left[\left(\frac{\partial \bar{\delta}}{\partial T} \right)^2 (\Delta T)^2 + \left(\frac{\partial \bar{\delta}}{\partial T_1} \right)^2 (\Delta T_1)^2 + \left(\frac{\partial \bar{\delta}}{\partial T_2} \right)^2 (\Delta T_2)^2 \right]^{1/2}$$

The following relationships hold for all three equations above:

$$\frac{\partial \bar{\delta}}{\partial T} = -\pi \frac{(T_2 - T_1)}{T^2}$$

$$\frac{\partial \bar{\delta}}{\partial T_1} = -\pi/T$$

$$\frac{\partial \bar{\delta}}{\partial T_2} = \pi/T$$

When two random errors contribute to a total error, the total error is the square root of the sum of the squares of the contributing errors. We divide the error into two parts, one below 1 kc and the other above 1 kc for the error introduced by the counter. Then,

$$(\Delta T)_{Total} = \left[(\Delta T)_{counter}^2 + (\Delta T)_{oscillator}^2 \right]^{1/2}$$

$$(\Delta T)_{Total} = \left[10^{-14} + (10^{-4} T)^2 \right]^{1/2}, F < 1 \text{ kc}$$

$$(\Delta T)_{Total} = \left[(10^{-1} T^2)^2 + (10^{-4} T)^2 \right]^{1/2}, F > 1 \text{ kc}$$

Also

$$\Delta T_1 = 10^{-6} \text{ sec}$$

and

$$\Delta T_2 = 10^{-6} \text{ sec}$$

Thus, the total phase error due to random error sources (excluding noise) is

$$\Delta \bar{\delta} = \left[\pi^2 \frac{(T_2 - T_1)^2}{T^4} \left\{ (10^{-9})^2 + (10^{-4} T)^2 \right\} + \frac{\pi^2}{T^2} (10^{-6})^2 + \frac{\pi^2}{T^2} (10^{-6})^2 \right]^{1/2}, \quad F < 1 \text{ kc} \text{ (radians)}$$

$$\Delta \bar{\delta} = \left[\pi^2 \frac{(T_2 - T_1)^2}{T^4} \left\{ (10^{-1} T^2)^2 + (10^{-4} T)^2 \right\} + \frac{\pi^2}{T^2} (10^{-6})^2 + \frac{\pi^2}{T^2} (10^{-6})^2 \right]^{1/2}, \quad F > 1 \text{ kc} \text{ (radians)}$$

It can be seen that the above expressions depend on both the phase and the

period of the input signal. Simplifying, we obtain

$$\Delta \bar{\delta} = \frac{\pi}{T} \left[\frac{(T_2 - T_1)^2}{T^2} \left\{ 10^{-14} + 10^{-8} T^2 \right\} + 2 \times 10^{-12} \right]^{1/2}, \quad F < 1 \text{ kc} \text{ (radians)}$$

and

$$\Delta \bar{\delta} = \frac{\pi}{T} \left[\frac{(T_2 - T_1)^2}{T^2} \left\{ 10^{-2} T^4 + 10^{-8} T^2 \right\} + 2 \times 10^{-12} \right]^{1/2}, \quad F > 1 \text{ kc} \text{ (radians)}$$

Let us consider the case for each of the above equations where F is one kilocycle and $T_2 \gg T_1$. Since neither T_2 nor T_1 can be greater than T , this means that

$$T_2 - T_1 \approx T \quad (\text{worst case})$$

Then

$$\begin{aligned} \Delta \bar{\delta} &\approx \frac{\pi}{10^{-3}} \left[\frac{T^2}{T^2} \left\{ 10^{-14} + (10^{-5})(10^{-3})^2 \right\} + 2 \times 10^{-12} \right]^{1/2} \\ &\approx \frac{\pi}{10^{-3}} \left[2 \times 10^{-12} \right]^{1/2} \approx 4.4 \times 10^{-3} \text{ radians.} \end{aligned}$$

and

$$\begin{aligned} \Delta \bar{\delta} &\approx \frac{\pi}{10^{-3}} \left[\frac{T^2}{T^2} \left\{ 10^{-12} \times 10^{-2} + 10^{-8} \times 10^{-6} \right\} + 2 \times 10^{-12} \right]^{1/2} \\ &\approx \frac{\pi}{10^{-3}} \left[2 \times 10^{-12} \right]^{1/2} \approx 4.4 \times 10^{-3} \text{ radians.} \end{aligned}$$

For very low frequencies the $(10^{-8}T^2)^{1/2}$ term will predominate, and

$$\Delta \bar{\delta} \approx \pi \times 10^{-4} \text{ radians}$$

For the highest frequency in question, 10 kilocycles,

$$\Delta \bar{\delta} \approx \frac{\pi}{T} (1.4 \times 10^{-6}) \approx 4.4 \times 10^{-2} \text{ radians.}$$

or 2.3 degrees.

The maximum total aggregate error due to both systematic and random errors is then

$$(\Delta \bar{\delta})_{\text{total}} = \left[(3.0)^2 + (2.3)^2 \right]^{1/2}$$

= 3.8 degrees.

Phase Measurements

From an operational point of view the phase calibration can be divided into two parts, i. e. , recording and measurement. The advantage of this division is that the recording takes relatively little time and can be performed during or immediately before or after sea trials. The necessary response data are thus preserved for detailed measurement at a later date.

It is the purpose of this section to describe the apparatus and procedure developed for the phase response measurements required by the project.

Figure 1 is a block diagram of the measurement circuit. The output from a sine-wave oscillator passes into an unknown electronic circuit whose phase response is to be determined. The phase of the output of this circuit is then measured with respect to the oscillator output. The unknown electronic circuit will, in general, have a gain or loss associated with it. To compensate for this, a 4 db step attenuator and an amplifier are placed in series with the output of the unknown circuit, as well as with that of the oscillator. With these devices it is possible to adjust the voltage outputs to be within 2 db of each other.

The unknown electronic circuit output may be inverted in polarity with respect to the reference signal. The measurement circuit is, therefore, equipped with a polarity reversing switch, S_2 , so that one of the outputs may be inverted.

These outputs then go to the "start" and "stop" triggers of a Beckman-Berkeley counter. With both triggers set at zero volts, the counter

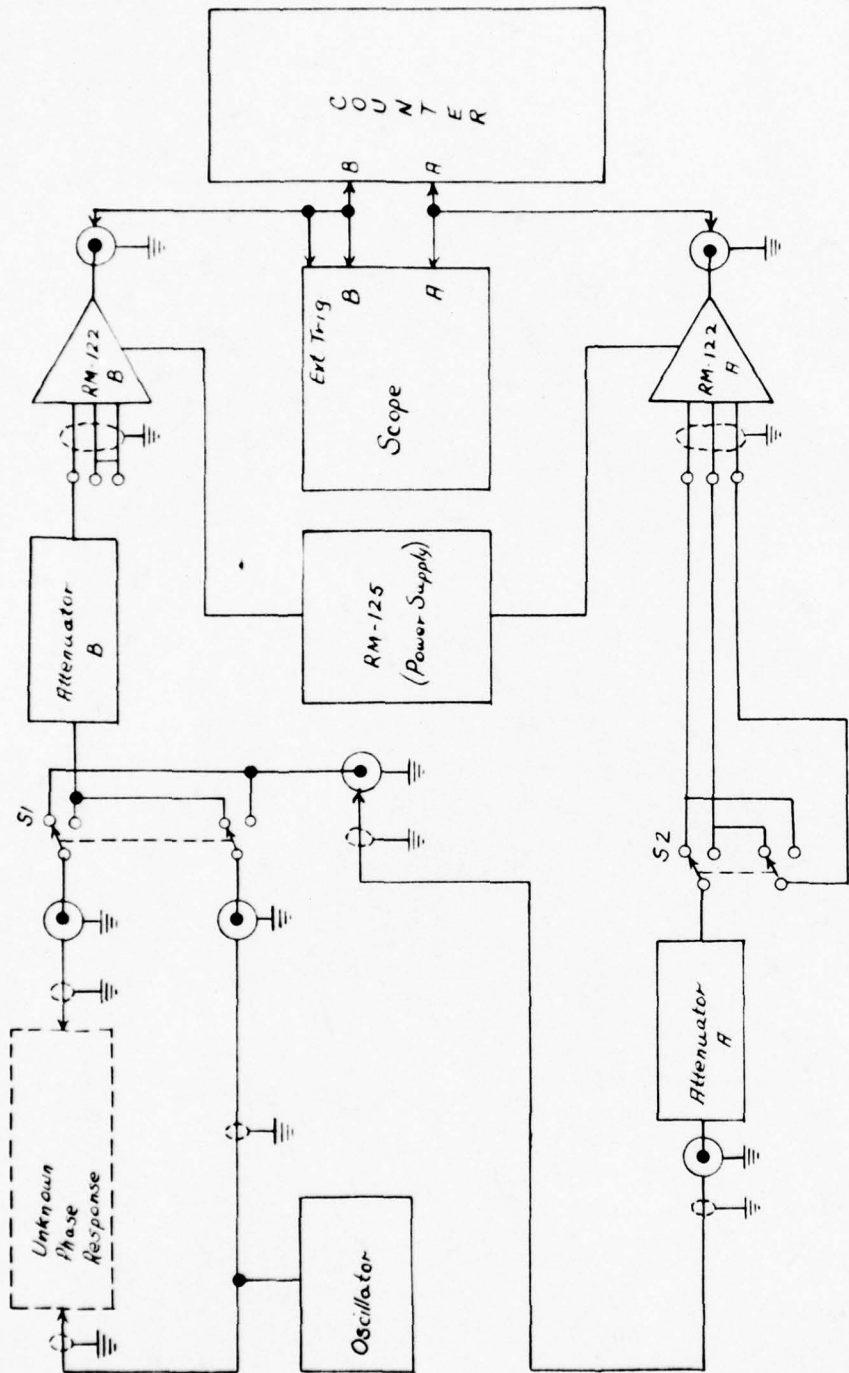

FIGURE 1
PHASE MEASUREMENT APPARATUS

will start when the phase of the reference voltage is zero, and will stop when the phase of the unknown system output is zero.

Since the two attenuator-amplifier circuits, "A" and "B", are made up of similar components, any phase shift introduced by one will be similar to that introduced by the other, and these should cancel. The method allows for removal of any residual phase shift in these circuits, as well as inaccuracies in setting of the counter trigger level. This method involves first, sending the reference signal through circuit "B", the starting trigger circuit, and the shifted signal through the stopping trigger circuit "A", and measuring the resulting time shift. The switch *S1* is then thrown, which sends the shifted signal through circuit "B" and the reference signal through circuit "A." The time shift is again measured. The period of the reference signal is also measured, and from these quantities the phase shift may be calculated.

The following is a step-by-step description of the phase measurement procedure.

1. Turn on the circuit. Allow a 5-minute warm-up period.
2. Insert the signal from the oscillator into the unknown component. Connect the output from the unknown to "Input A" of Preamplifier No. 1. Connect the oscillator output to "Input B" of this preamplifier also.
3. Set the preamplifier frequency response switches at 0.2 cps low cutoff and 40 kc high cutoff.

Note: This setting should be used for the lowest frequencies

to be measured. For higher frequencies it may be desirable to eliminate low-frequency noise by setting the low cutoff at some higher value. Be sure that both preamplifiers are set for the same cutoff frequencies so that phase characteristics are matched.

4. Adjust the counter starting trigger level to zero. With the reference signal feeding into counter input "B", adjust the trigger level until the counter starts. Decrease the reference signal voltage and continue adjusting the trigger level such that it starts the counter. Continue this procedure until the voltage into the trigger is about 0.3 v peak-to-peak--the threshold sensitivity of the trigger. The starting trigger level is now set as close to zero as possible.
5. Adjust the counter stopping trigger level to zero. With the unknown signal feeding into counter input "A" and the reference signal set to a high value, feeding into input "B", set the stopping trigger level until the counter stops. Reduce the unknown signal, adjusting the stopping trigger as described above, until the unknown signal level is about 0.3 v peak-to-peak. Both trigger levels are now set for zero.
6. Set the oscillator for the desired frequency. This may be

set quite accurately using the "Per B" setting or, for frequencies above 1 kc, the "EPUT" setting of the counter.

7. Adjust the attenuators and "Approximate Voltage Gain" controls on the preamplifiers until the reference and shifted signals are nearly equal and near 10 volts peak-to-peak. These may be set using the oscilloscope.
8. Set the counter function-switch to "EPUT" and measure the time lag between the two input waveforms. Repeat several times and take the average value.
9. Throw the "Reversing" switch on Preamplifier No. 1 and repeat Step 7.
10. Repeat Steps 6, 7, 8, and 9 for the next higher frequency.

Note: When measuring phase from recorded data, feed the reference channel to "input B" and the unknown channel to "input A" of Preamplifier No. 1. Step No. 6 will consist of merely measuring the period with the counter; the trigger levels should be previously set with an oscillator.

Calculation of Phase Relations

The phase measurement technique described in the section entitled "Phase Measurements" will yield three measured quantities for each frequency.

These are;

T_1 , the time lag using the reference signal to start the counter,

T_2 , the time lag using the shifted signal to start the counter, and

T , the period of the reference signal (for frequencies 1000 cps or below), or

$f = \frac{1}{T}$, the frequency of the reference signal (for frequencies 1000 cps or above).

From these measured quantities the phase shift, ϕ , must be calculated for each frequency and the time shift, Δt , must be calculated for each spectrum of frequencies.

a. Calculation of Apparent Phase Shift

The first step in these calculations is the calculation of the apparent phase shift. One of the three following equations must be used.

$$\bar{\delta} = (180^\circ) \left[\frac{-T_2 - T_1}{T} \right]$$

$$\bar{\delta} = (180^\circ) \left[\frac{T + T_2 - T_1}{T} \right]$$

$$\bar{\delta} = (180^\circ) \left[\frac{-T + T_2 - T_1}{T} \right]$$

The best procedure to follow is that of determining the quadrant

in which the phase angle falls by inspection with an oscilloscope and using the equation giving the angle in the proper quadrant.

b. Calculation of Time Shift

It is known that

$$\bar{\delta} = \phi + f \Delta t,$$

the symbols having been defined above. The time shift Δt may be found by a simple least squares calculation.

Since we are measuring phase responses of each FM data channel with the FM reference channel, we may assume that over the normal FM recording spectrum (i. e. , DC to 5000 cps)

$$\phi \approx 0.$$

The dependent variable is $\bar{\delta}$, the independent f . The unknown is then Δt .

To perform this calculation, we use the equation for least squares fitting

$$\sum \bar{\delta}_i f_i = \Delta t \sum f_i^2$$

Once Δt is calculated, the residual values of ϕ may be found by referring to the equation

$$\bar{\delta} = \phi + f \Delta t.$$

PRESENTATION OF TEST RESULTS

Utilizing the techniques and measurement procedures previously described, the following measurements were obtained and are presented herein.

Preliminary Phase Measurement of Typical Systems

Figures 2 and 3 illustrate phase shift of the instrumentation between the transducer output and the tape recorder unit. (See Figure 4.) The purpose of this measurement was to determine the phase response of two typical instrumentation systems in order to choose frequencies for subsequent calibrations. This measurement also compares the phase responses of one instrumentation system with the calibration signal inserted into the hydrophone preamplifier input (see dotted circuit, Figure 4) to a calibration with the signal fed down the cable, as is normally done in an "amplitude calibration". Figure 2 illustrates the effect of inserting calibration signals down the cable. Figure 3 compares typical instrumentation channels and illustrates the effect of changes in equalizer settings.

Phase Response of Instrumentation System and Tape Transports

Sine wave signals were inserted into the hydrophone preamplifiers via the calibration circuits. The resulting outputs of the hydrophone instrumentation circuits were recorded by FM mode along with a reference signal from the driving oscillator. The channel containing this reference signal will be called the "FM Reference Channel"; the channels containing the hydrophone instrumentation outputs will be called the "data channels". Figure 4a shows

the block diagram of a typical recording configuration.

Tapes were also recorded which provide for calibration of the tape transports themselves. A calibration signal was paralleled into all channels of both the transports (see Figure 4b) used on the LITTLEHALES and MONOB. By use of the above recordings the following were derived:

- a. Measured apparent ϕ_T between data and reference channels of the tape recorders (Figures 5 through 11).
- b. Measured apparent ϕ_{FE} between the data and reference channels of the tape recorder and associated instrumentation (Figures 12 and 13).
- c. Calculated actual ϕ_E for each data instrumentation channel (Figures 14 and 15).
- d. Measured apparent ϕ_T between FM and direct reference channels for each tape recorder (Figures 16 and 17), and
- e. Calculated actual ϕ_T for each reference channel (Figures 16 and 17).

The phase responses of the LITTLEHALES electronic systems were recorded with the high-pass filters set at 5 cps. During the sea trials these filters were set at 50 cps for the deep and intermediate hydrophones and at 200 cps for the shallow hydrophone. To arrive at the phase responses of the systems as used in the trials, it was necessary to calibrate these filters separately.

Figures 18, 19, and 20 give the responses of the shallow intermediate and deep hydrophones respectively. In each case the curve connecting the dots represents the correction to be applied to the hydrophone response curve.

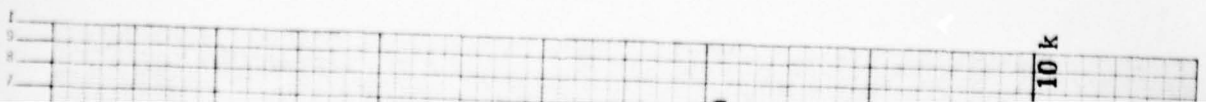

Figure 21 shows the true corrected response curves for the LITTLEHALES hydrophone electronics systems.

The above graphs present the basic information related to the phase response of the instruments used in the test program. Measurement of ϕ_H , the hydrophone phase response, has not yet been completed; this will be treated in a later report.

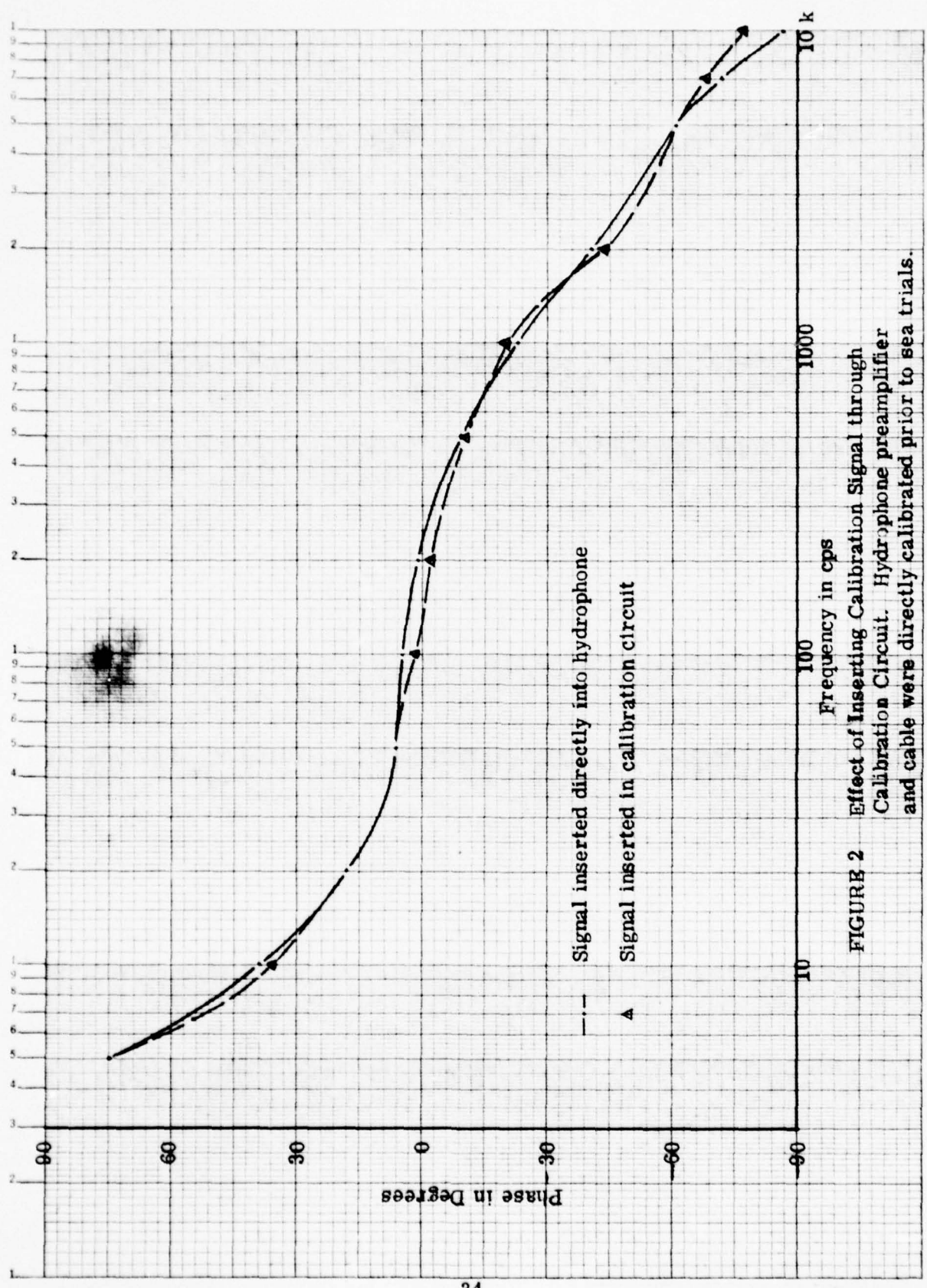
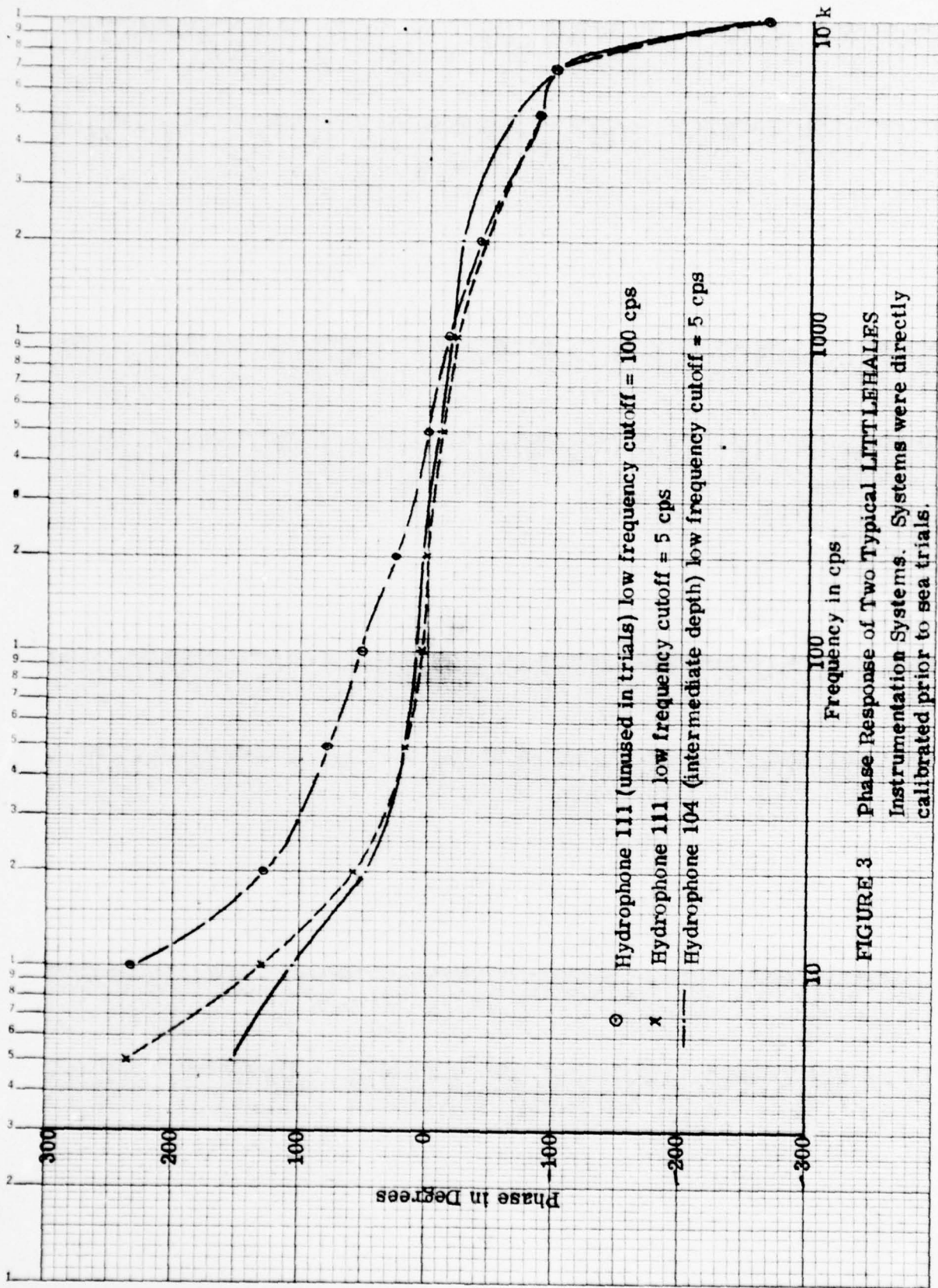

FIGURE 2 Effect of Inserting Calibration Signal through Calibration Circuit. Hydrophone preamplifier and cable were directly calibrated prior to sea trials.



○ Hydrophone 111 (unused in trials) low frequency cutoff = 100 cps
x Hydrophone 111 low frequency cutoff = 5 cps
- · - Hydrophone 104 (intermediate depth) low frequency cutoff = 5 cps

FIGURE 3 Phase Response of Two Typical LITTLEHALES Instrumentation Systems. Systems were directly calibrated prior to sea trials.

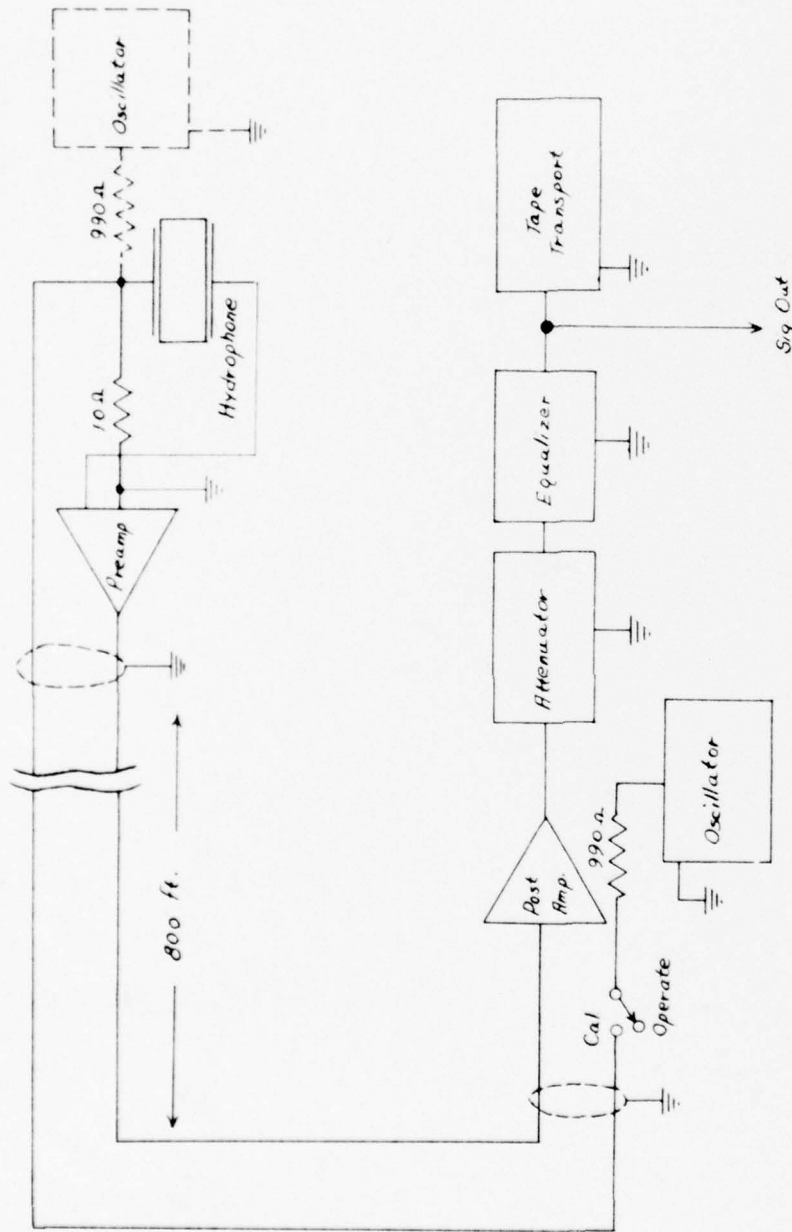

FIGURE 4 Block Diagram of Typical Hydrophone Instrumentation .
 Calibration signals were inserted via the "Cal" circuit
 and directly into the hydrophone (as in dotted circuit).

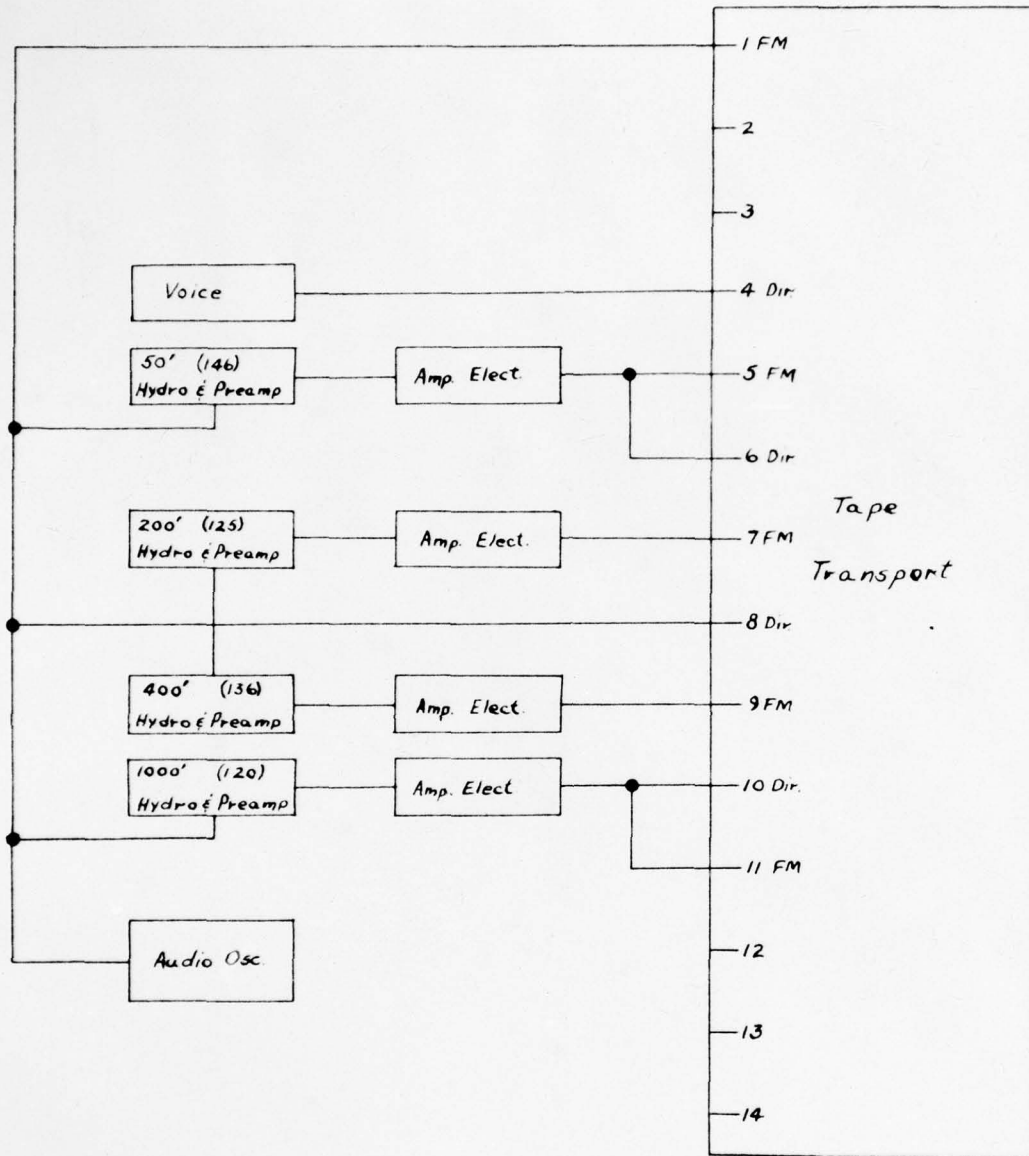

FIGURE 4a Instrumentation Block Diagram
for Systems Calibration on MONOB

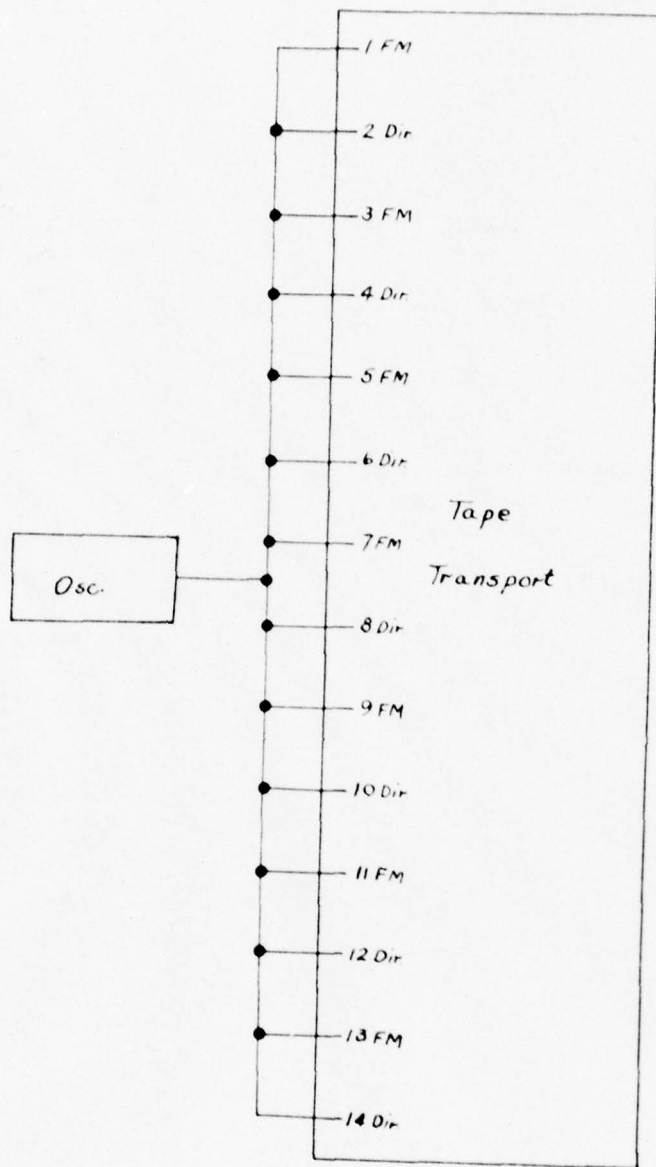

FIGURE 4b Instrumentation Block Diagram for
Tape Recorder Calibration

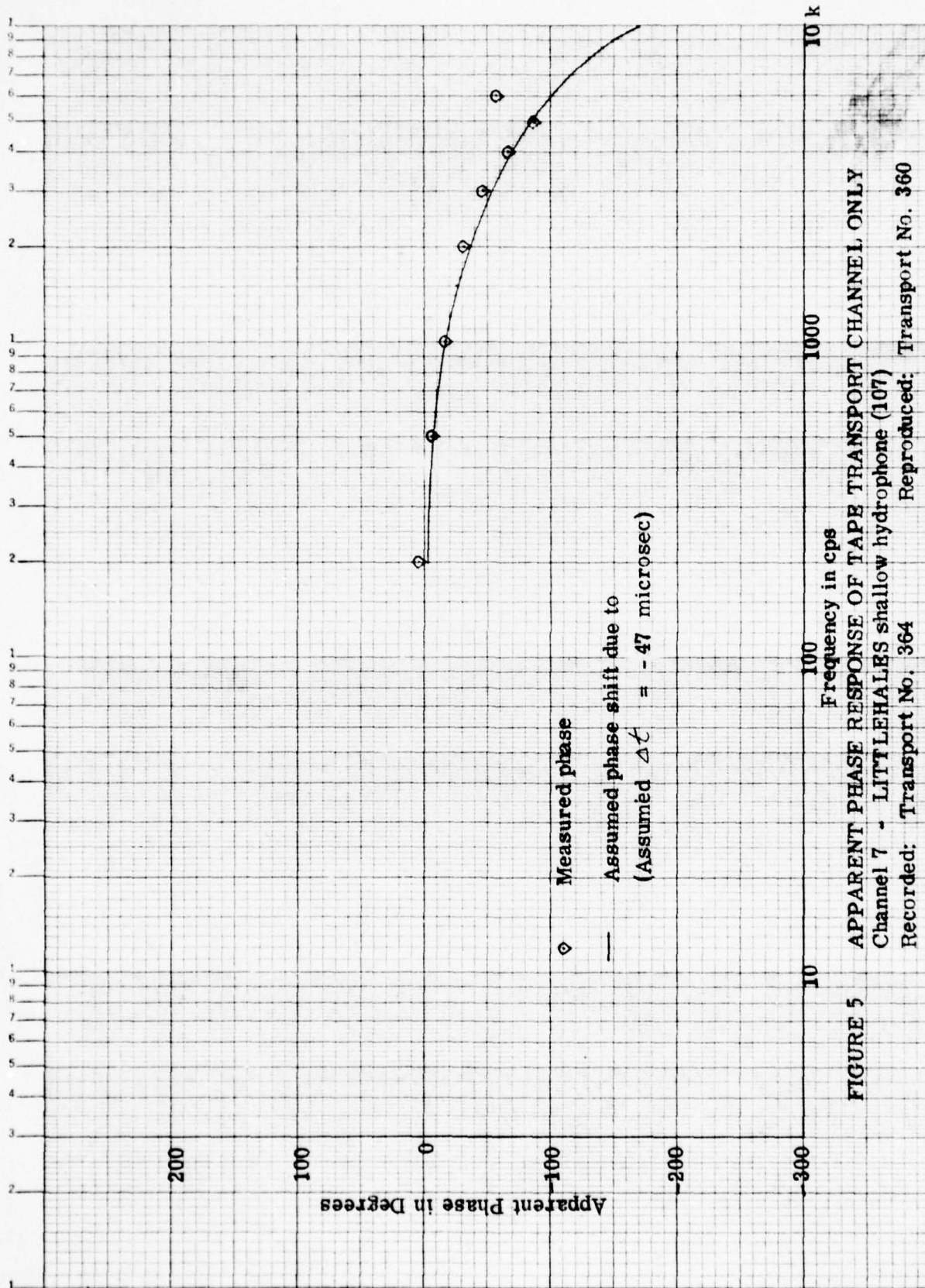

FIGURE 5 APPARENT PHASE RESPONSE OF TAPE TRANSPORT CHANNEL ONLY
 Channel 7 - LITTLEHALES shallow hydrophone (107)
 Recorded: Transport No. 364
 Reproduced: Transport No. 360

LOGIC MIC 9.81
NEUFELDER CO.
4 CYCLES X 70 DIVISIONS

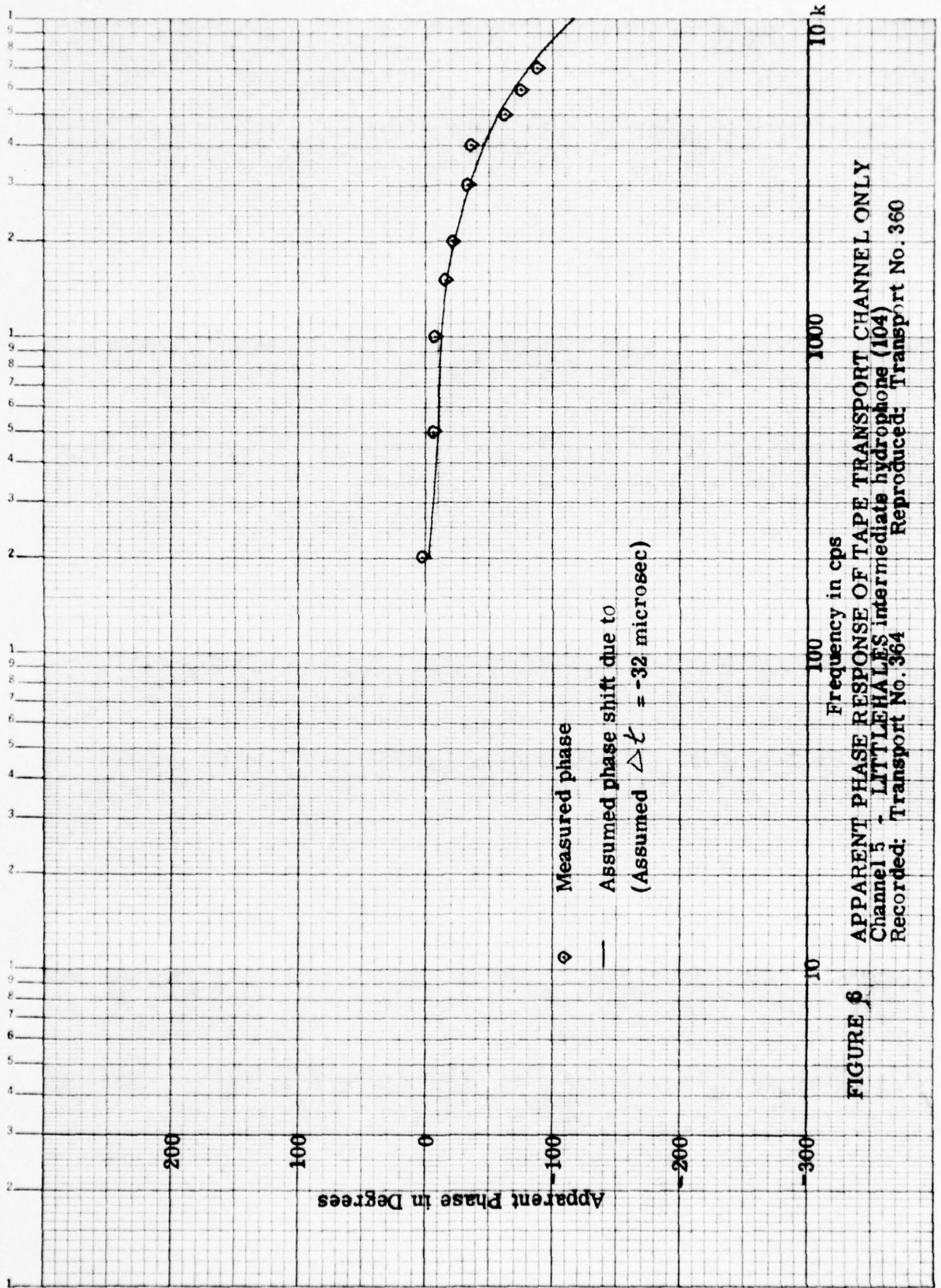
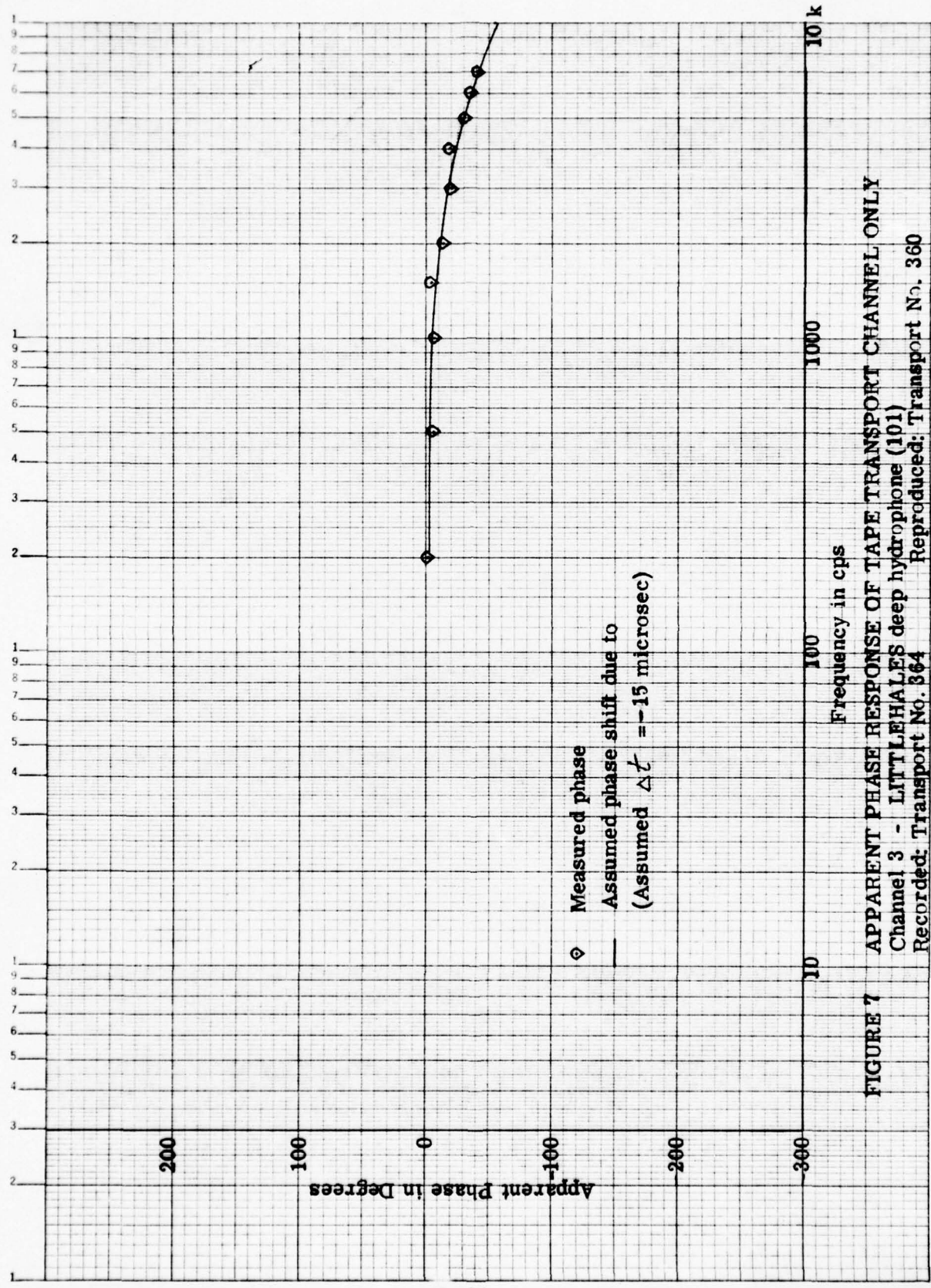

FIGURE 6 APPARENT PHASE RESPONSE OF TAPE TRANSPORT CHANNEL ONLY
Channel 5 - LITTLEHALES intermediats hydrophone (104)
Recorded: Transport No. 364 Reprinted: Transport No. 360

STANDARD LOGARITHMIC SCALE
 STUFFLEBESSER CO. MADE IN U.S.A.
 4 CYCLES X 70 DIVISIONS



◇ Measured phase
 — Assumed phase shift due to
 (Assumed $\Delta t = -15$ microsec)

FIGURE 7 APPARENT PHASE RESPONSE OF TAPE TRANSPORT CHANNEL ONLY
 Channel 3 - LITTLEHALES deep hydrophone (101)
 Recorded: Transport No. 364 Reproduced: Transport No. 360

FOE
 100-20GA
 KEUFFEL & ESSER CO.
 4 CYCLES X 70 DIVISIONS

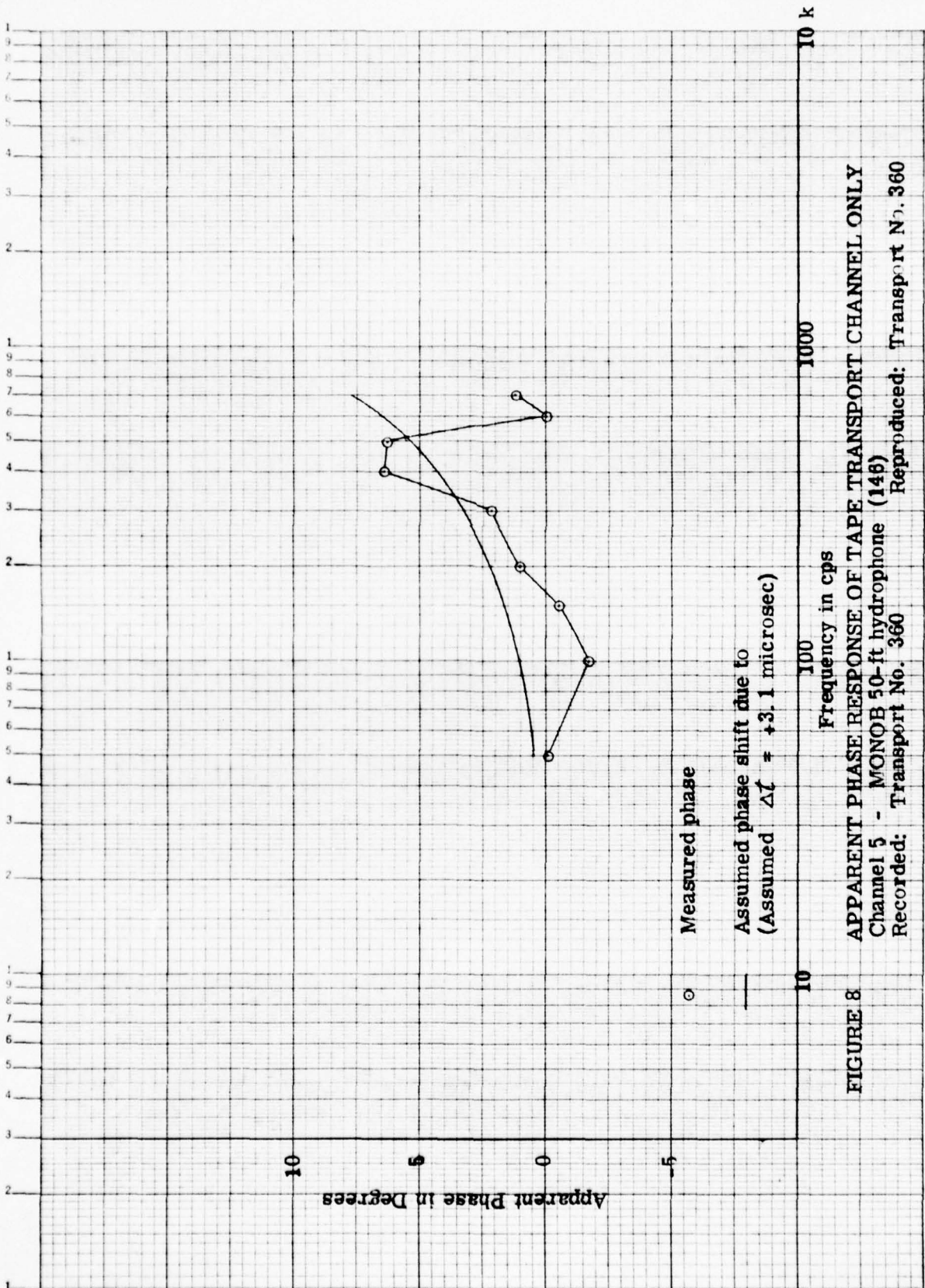
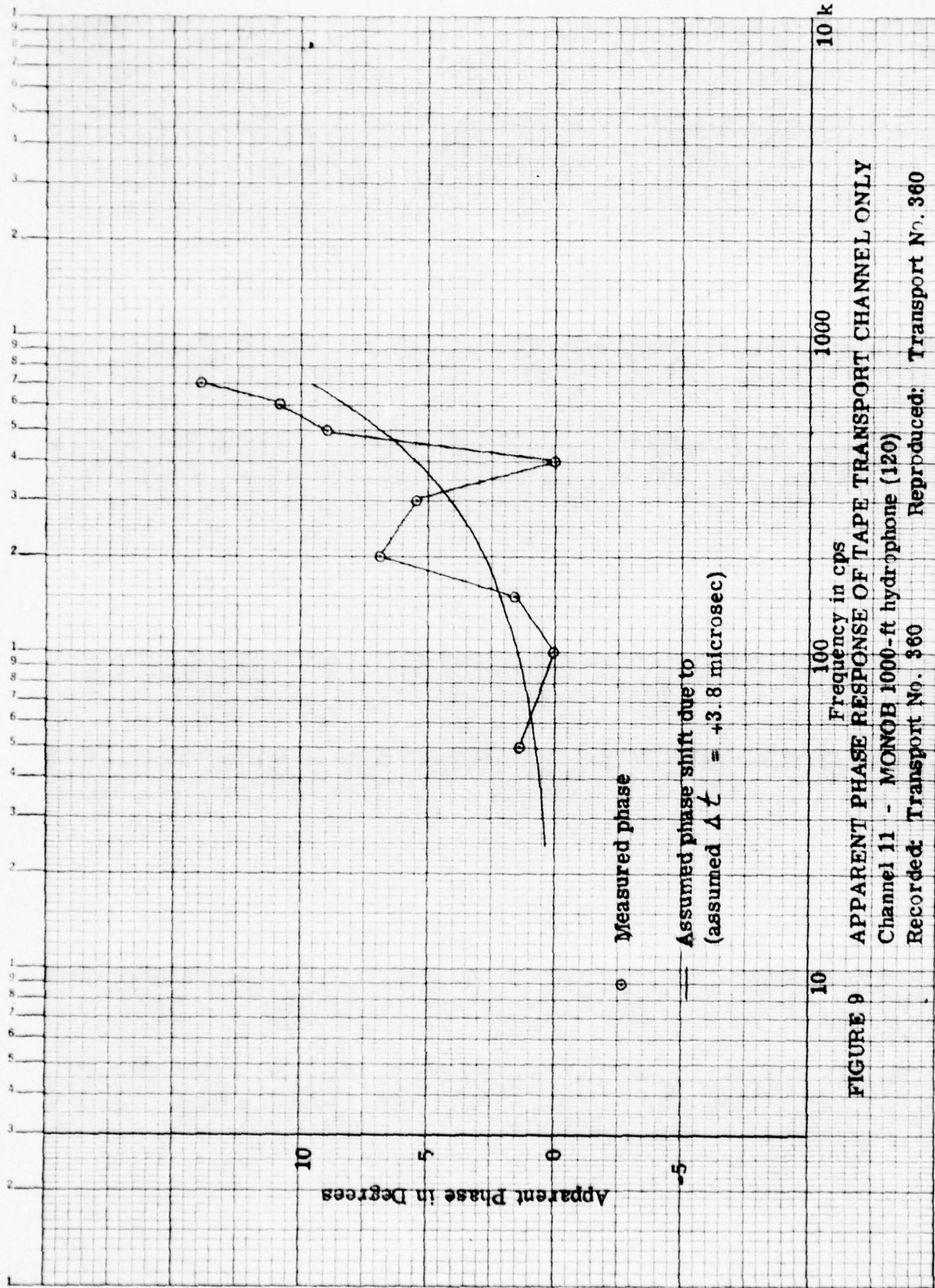

FIGURE 8 APPARENT PHASE RESPONSE OF TAPE TRANSPORT CHANNEL ONLY
 Channel 5 - MONOB 50-ft hydrophone (148)
 Recorded: Transport No. 360
 Reproduced: Transport No. 360



LOG MIC 19-8
KEUFEL & ESSER CO. MADE IN U.S.A.
4 CYCLES X 70 DIVISION

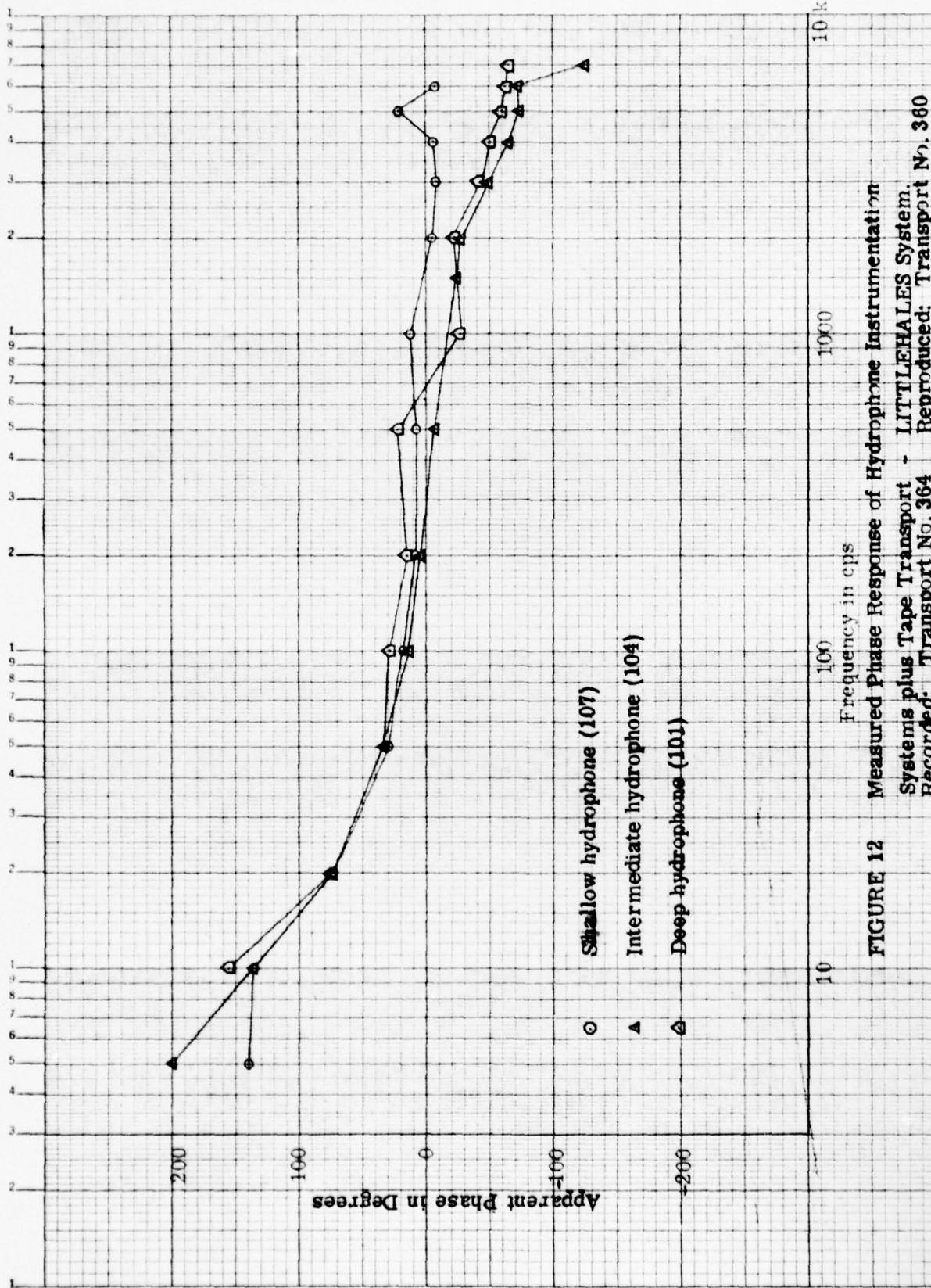

FIGURE 12 Measured Phase Response of Hydrophone Instrumentation Systems plus Tape Transport - LITTLEHALES System. Recorded: Transport No. 364 Reproduced: Transport No. 360

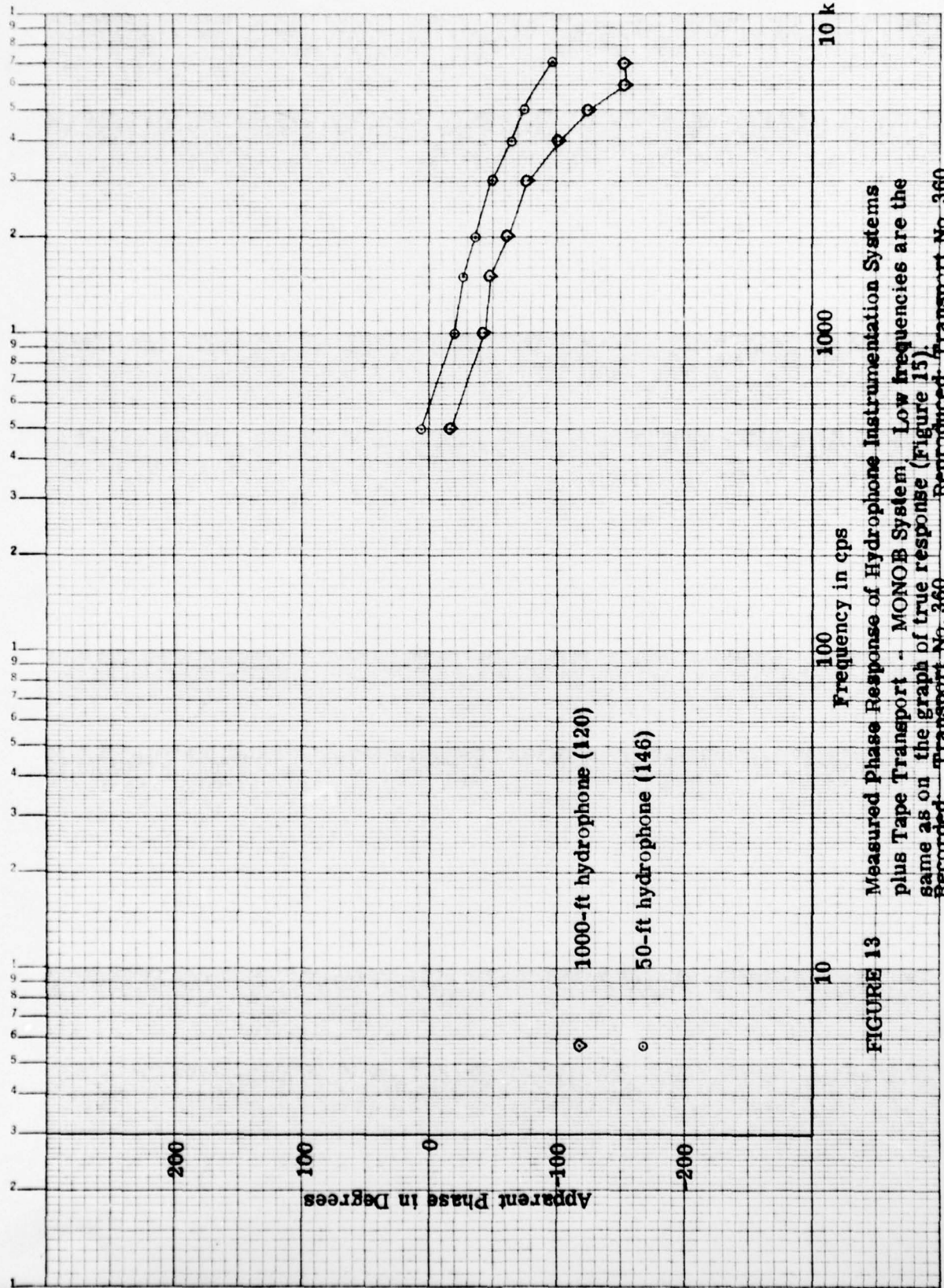

FIGURE 13 Measured Phase Response of Hydrophone Instrumentation Systems plus Tape Transport - MONOB System. Low frequencies are the same as on the graph of true response (Figure 15).
 Recorded: Transport No. 360
 Reproduced: Transport No. 360

KEE
 SEMI-LOGARITHMIC
 KEUFFEL & ESSER CO.
 5 CYCLES X 10 DIVISIONS

LOG MIC 39-B
KEUFFEL & ESSER CO. 4 CYCLES X 70 DIVISIONS

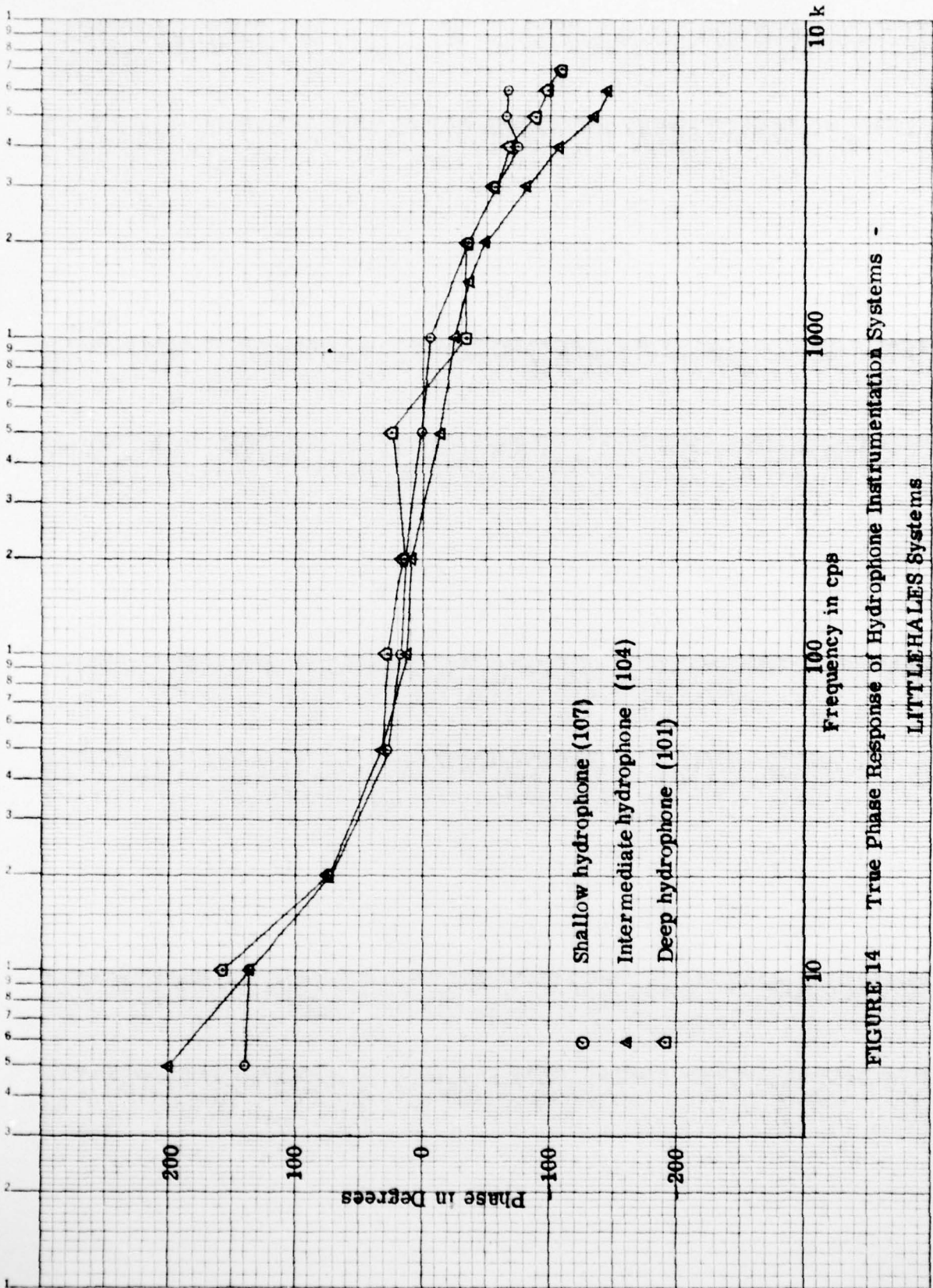

FIGURE 14 True Phase Response of Hydrophone Instrumentation Systems - LITTLEHALES Systems

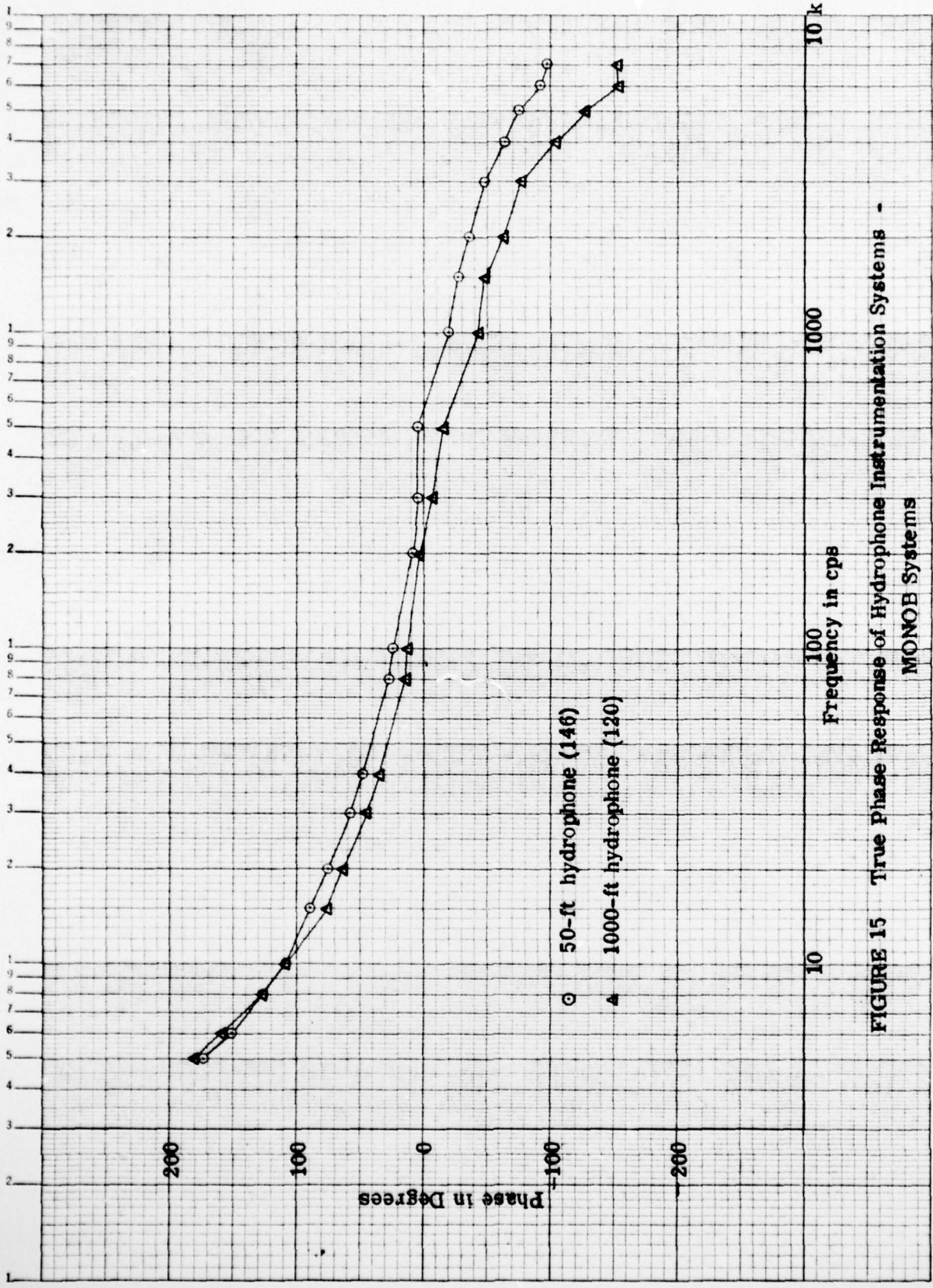

FIGURE 15 True Phase Response of Hydrophone Instrumentation Systems - MONOB Systems

9-81
 NEUFEL & KESSER CO.
 4 CYCLES X 70 DIVISIONS

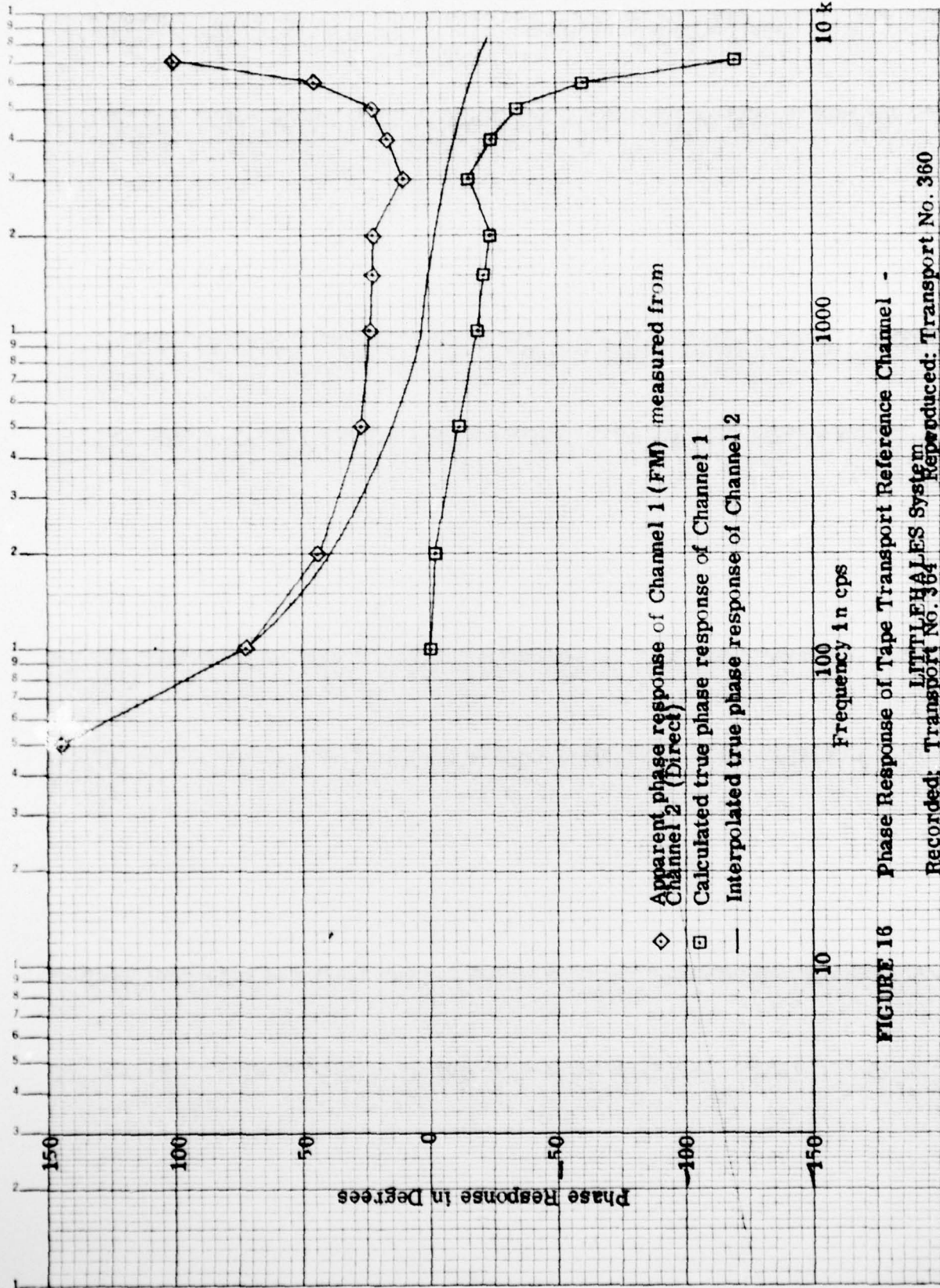

FIGURE 16 Phase Response of Tape Transport Reference Channel -
 LITTLEHALLES System
 Recorded: Transport No. 364 Reproduced: Transport No. 360

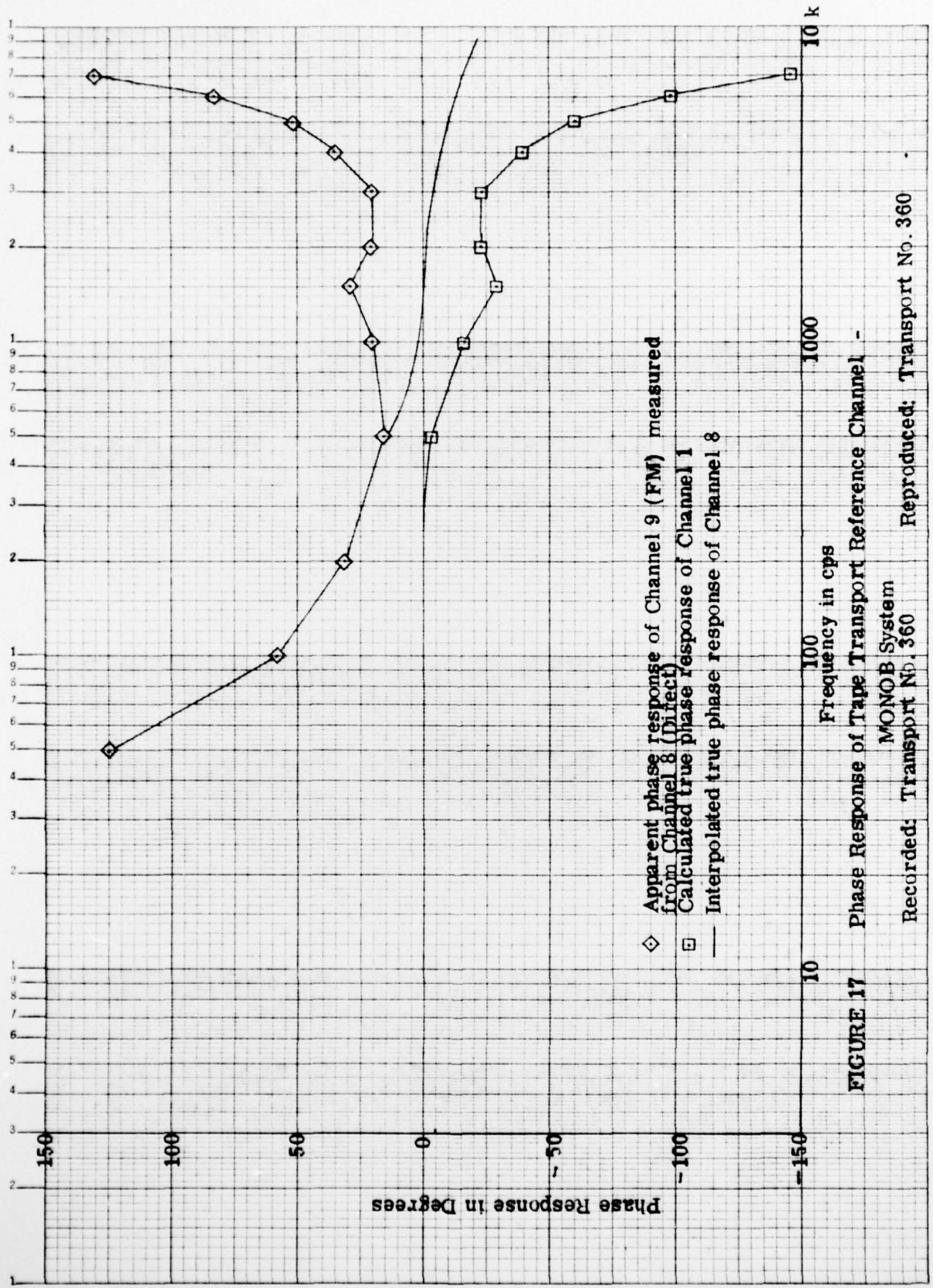

FIGURE 17 Phase Response of Tape Transport Reference Channel -
 MONOB System
 Recorded: Transport No. 360 Reproduced: Transport No. 360

LOGICAL IC 3-B1
 KEUFFEL & ESSER CO.
 4 CIRCLES & 70 DIVISIONS

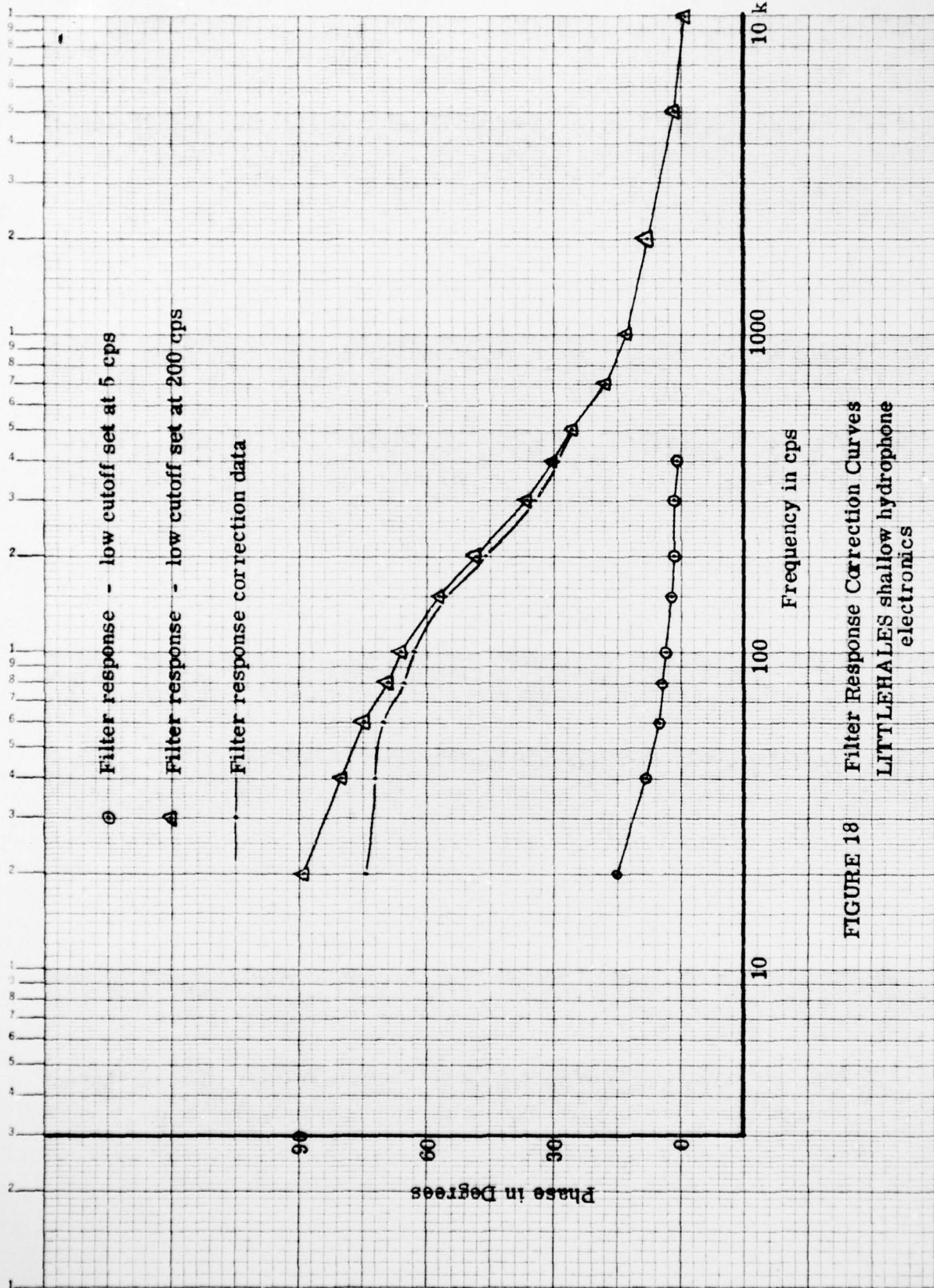

FIGURE 18 Filter Response Correction Curves
LITTLEHALES shallow hydrophone
electronics

LOG MIC 39-B
 KEUFEL & ESSER CO.
 4 CYCLES A TO DIVISION

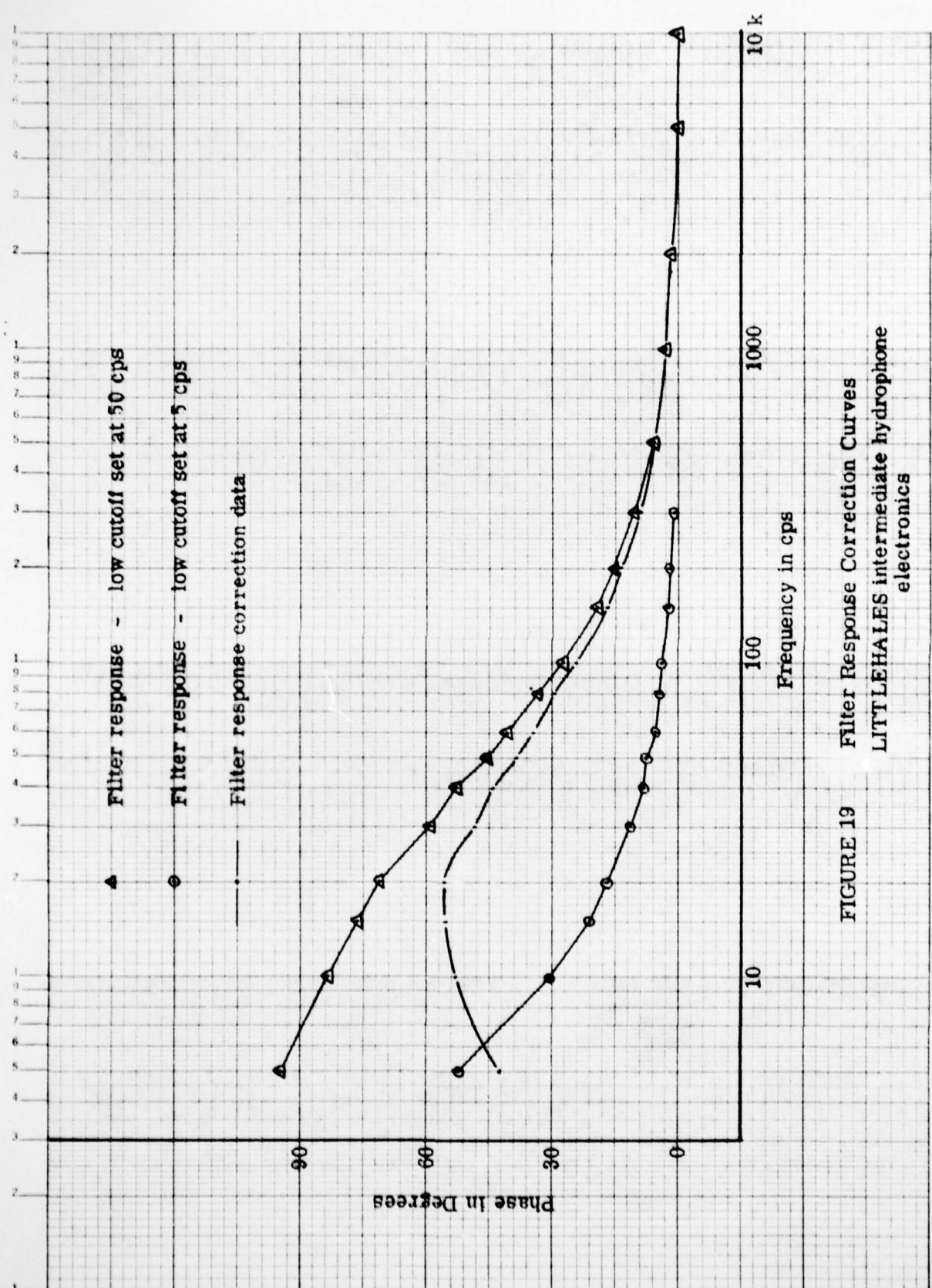

FIGURE 19 Filter Response Correction Curves
 LITTLEHALES intermediate hydrophone electronics

K&E SIMULOGARITHMIC (20:1) KEUFFEL & ESSER CO. PHILADELPHIA, PA.
 4 CYCLES X 10 DIVISIONS

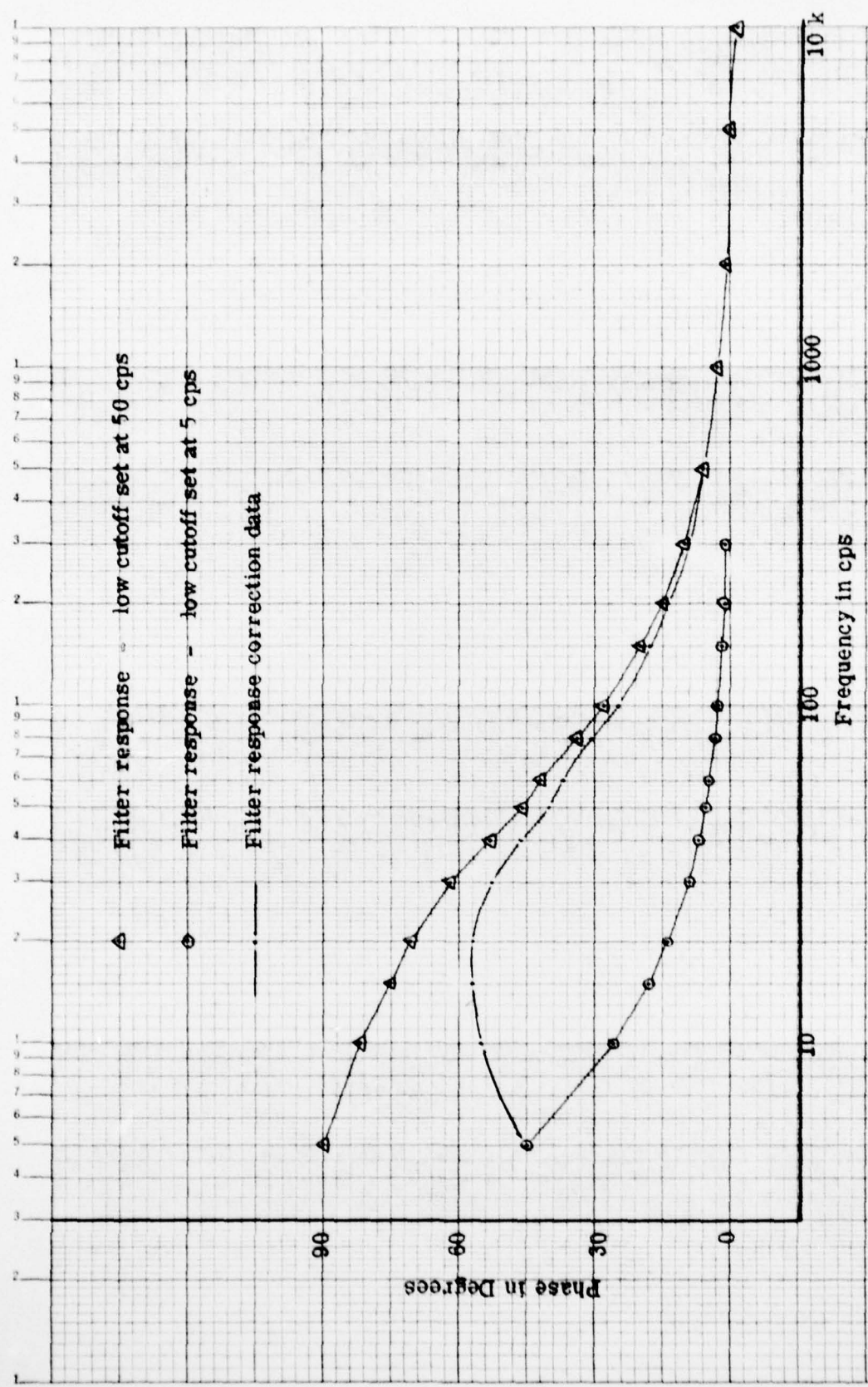

FIGURE 20
 Filter Response Correction Curves
 LITTLEHALFS deep hydrophone electronics

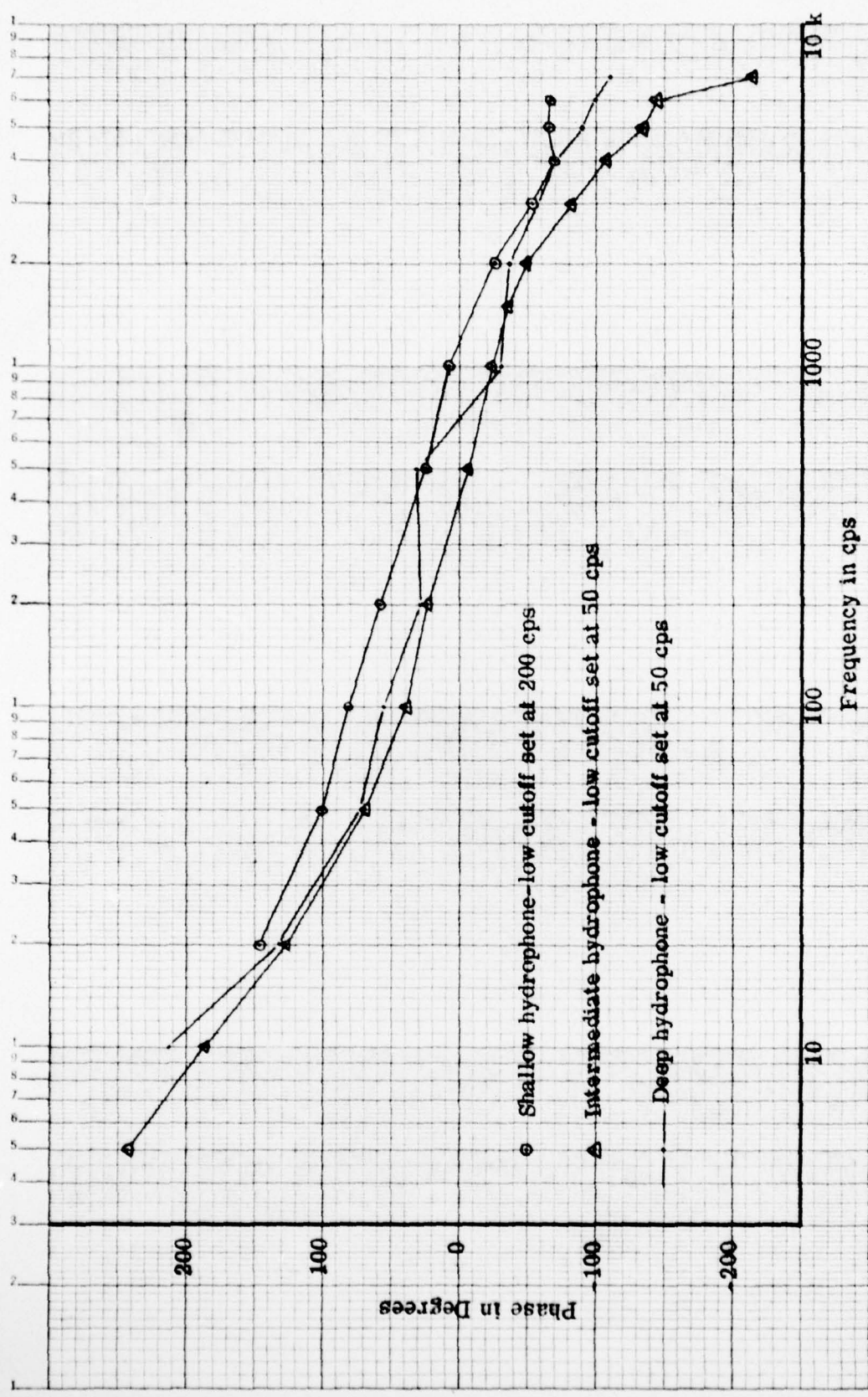

FIGURE 21 Corrected True Phase Response of
 Hydrophone Electronics -
 LITTLEHALES systems

CONCLUSIONS

The following preliminary conclusions may be drawn:

By phase measurement of a narrow-band amplifier in the laboratory, the technique of recording and measurement has been shown to be satisfactory to measure phase shifts to within ± 5 degrees, from 5 cps to 7 kc.

The timing counter method of phase calibration used herein is very susceptible to error due to extraneous noise. An example of error introduced by noise is the phase calibration of the LITTLEHALES deep hydrophone (Figure 14). When generating phase calibration tapes it is important to insure that the hydrophones are not subject to vibration, and

Comparison of two sets of phase response measurements for a hydrophone electronic system, made at different times, shows a wide variation in phase characteristics at both ends of its passband. A typical variation is that of the LITTLEHALES intermediate hydrophone, as shown in Figures 3 and 14. The low frequency variation may be due to change in hydrophone dielectric constant with temperature. The high frequency variation has not yet been explained due to insufficient data.

For hydrophone cables of less than about two thousand feet in length it is satisfactory to insert phase calibration signals through the standard calibration circuits for the hydrophone electronics. Thus, it is possible to get an on-site phase calibration of an array at sea.

It is possible to get an approximate absolute phase calibration of tape recorder data channels by measuring phase shifts between an FM record channel and a direct record channel, and through subsequent interpolation.

ANTICIPATED FUTURE EFFORT

It was recognized that this first attempt to collect data for the Acoustic Data Processing Research Program would be exploratory in nature. A primary goal of this effort has been to define the problems of acquiring appropriate data. This report presents the efforts, to date, related to phase calibration which is one of the many measurement problems. However, additional problems related to phase calibration may appear during data processing. Therefore, it is too early to evaluate the calibrations performed to date in terms of required modifications to technique and procedure to meet future requirements. It is our intent to work with the team members who will process and analyze the data and jointly evaluate the phase measurement techniques and procedures. Based upon the information obtained, a report will be prepared proposing measurement and calibration techniques and procedures to be used in the next full scale trial effort.

Certain preliminary recommendations may be made at this stage, however. These are outlined below.

Laboratory Phase Calibration of Hydrophone Electronics

As described in the previous section, the hydrophone electronics systems show variations in measured phase characteristics for different calibration tests. A series of laboratory tests should be made to define the parameters causing these variations and, hopefully, to eliminate or correct for them.

On-Site Phase Calibrations

It has been shown to be feasible to insert phase calibration signals into the standard hydrophone calibration circuits with the hydrophone array in place at sea. It is strongly recommended that in future sea trials, phase calibrations be done on station. This would eliminate the possibility of losing data due to hydrophones malfunctioning before the phase calibration can be performed, as happened on MONOB. Such an on-site calibration could be performed in less than 45 minutes.

The performance of such an on-site calibration should not preclude the calibration of hydrophones at the end of sea trials, however. It has not yet been determined whether "quiet ship" conditions reduce ambient waterborne noise enough so that an accurate on-site phase calibration can be obtained.

Tape Recorder Calibration using Phase-Locked Oscillators

A more accurate method of getting an absolute phase calibration of tape recorder channels would be with the use of phase-locked oscillators. A block diagram of such a set of oscillators is shown in Figure 21. With such a system, successive frequencies could be recorded on a channel to be calibrated, with a constant frequency recorded as reference. This reference frequency would provide a constant phase standard for determination of absolute phase.

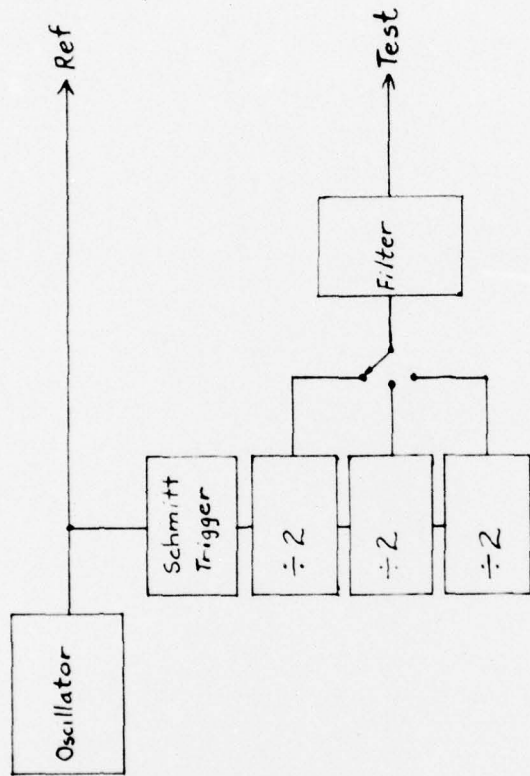

FIGURE 21

PROPOSED SYSTEM FOR TAPE RECORDER CALIBRATION
 USING PHASE-LOCKED OSCILLATORS.

Recommended Time Coordination Procedure

The problem of time coordination is one of establishing the location of a given instant on the tape records from both transports. For this purpose a series of square wave signals, from 10 kc to 0.1 cps, are recorded on separate channels simultaneously with the hydrophone data on both tape transports. The frequencies are 10 kc, 1 kc, 10 cps, and 0.1 cps. The 10 kc signal is, of necessity, recorded by direct mode; all others are recorded by FM mode.

These signals were generated by two 10-mc crystal-controlled oscillators and decade frequency dividing circuits. The oscillators were of high enough stability that, with the two synchronized at the beginning of the test series, a time relationship of sufficient accuracy was maintained throughout.

Time coordination is by the 1 kc signal. This signal is recorded on the same head as the data channels. The time-shifts of the data channels with respect to the 1 kc channel are accurately known, having been determined with a least-squares fit of phase responses as described on page 31. The time location of any point on the 1 kc signals of the two tape transports is assumed to be identical. Since both recordings are made on Precision Instrument tape transports with identical FM-record modules, this assumption should be valid.

A possible system for extracting data of identical instants on two tapes is that of using an electronic triggering mechanism and allowing the 1 kc or 10 kc reference signal to operate a digitizing device. The time-shifts measured as described above would then be applied to these data for time correction. If the 10 kc reference channel is used it will be necessary to measure the time-shift between the 1 kc and 10 kc reference channels using the counting method of the phase calibration.