

AD-A076 456

AIR FORCE INST OF TECH WRIGHT-PATTERSON AFB OH SCH00--ETC F/G 5/9
JOB SATISFACTION: LITERATURE REVIEW AND EMPIRICAL TEST OF A JOB--ETC(U)
SEP 79 T R TALBOT
AFIT/GSM/SM/79S-14

UNCLASSIFIED

NL

1 of 2

AD
A076456



1

REPORT DOCUMENTATION PAGE

READ INSTRUCTIONS
BEFORE COMPLETING FORM

14

1. REPORT NUMBER AFIT/GSM/SM/79S-14
2. GOVT ACCESSION NUMBER
3. RECIPIENT'S CATALOG NUMBER Master's Thesis

6

4. TITLE (and Subtitle) JOB SATISFACTION: LITERATURE REVIEW AND EMPIRICAL TEST OF A JOB FACET SATISFACTIONS MODEL
5. TYPE OF REPORT & PERIOD COVERED MS Thesis

12

6. PERFORMING ORG. REPORT NUMBER
7. AUTHOR(s) Terry R. Talbot
Captain USAF
8. CONTRACT OR GRANT NUMBER(s)

9. PERFORMING ORGANIZATION NAME AND ADDRESS Air Force Institute of Technology (AFIT/EN)
Wright-Patterson AFB, Ohio 45433
10. PROGRAM ELEMENT, PROJECT, TASK AREA & WORK UNIT NUMBERS

11. CONTROLLING OFFICE NAME AND ADDRESS Air Force Institute of Technology (AFIT/EN)
Wright-Patterson AFB, Ohio 45433
12. REPORT DATE September 1979
13. NUMBER OF PAGES 184

14. MONITORING AGENCY NAME & ADDRESS (if different from Controlling Office)
15. SECURITY CLASS. (of this report) Unclassified
15a. DECLASSIFICATION/DOWNGRADING SCHEDULE

AD A 076456

LEVEL 4

16. DISTRIBUTION STATEMENT (of this Report) Approved for public release; distribution unlimited
17. DISTRIBUTION STATEMENT (of the abstract entered in Block 20, if different from Report)

DDC REPRODUCED NOV 9 1979 RECEIVED E

18. SUPPLEMENTARY NOTES Approved for public release; IAW AFR 190-17
JOSEPH P. HIPPS, Major, USAF
Director of Information

DDC FILE COPY

19. KEY WORDS (Continue on reverse side if necessary and identify by block number)
Job Satisfaction
Work Satisfaction
Job Design
Quality of Working Life

20. ABSTRACT (Continue on reverse side if necessary and identify by block number)
The broad objective of this study was to examine the nature and causes of job satisfaction. This was pursued through a literature review of the more popular theories and models pertaining to job satisfaction. Included in the review are summaries of Maslow's and Alderfer's need hierarchy theories, achievement motivation theory, Herzberg's motivation-hygiene theory, expectancy theory, job characteristics theories, discrepancy theory, equity theory, and studies relating to the clustering of facet satisfactions. The specific

UNCLASSIFIED

SECURITY CLASSIFICATION OF THIS PAGE(When Data Entered)

objective of this research was to test the efficacy of a three cluster model of facet satisfactions. This was accomplished through a survey which was completed by 267 Air Force officers attending Squadron Officer School and Air Command and Staff College. Conclusions reached by the study were that for Air Force officers in the ranks of captain and major: 1. Job satisfaction is higher for older officers who have more time in the service. 2. There is no evidence of a relationship between education level and job satisfaction. 3. Non-rated officers are more satisfied with their jobs than rated officers. 4. Work environment facet satisfactions are interpreted by employees to form three clusters: job properties, interaction features, and organization policy variables. 5. The three clusters of facet satisfactions vary in importance to overall job satisfaction with job properties being most important and organization policies being least important.



UNCLASSIFIED

SECURITY CLASSIFICATION OF THIS PAGE(When Data Entered)

REPORT DOCUMENTATION PAGE		READ INSTRUCTIONS BEFORE COMPLETING FORM
1. REPORT NUMBER	2. GOVT ACCESSION NO.	3. RECIPIENT'S CATALOG NUMBER
4. TITLE (and Subtitle)		5. TYPE OF REPORT & PERIOD COVERED
		6. PERFORMING ORG. REPORT NUMBER
7. AUTHOR(s)		8. CONTRACT OR GRANT NUMBER(s)
9. PERFORMING ORGANIZATION NAME AND ADDRESS		10. PROGRAM ELEMENT, PROJECT, TASK AREA & WORK UNIT NUMBERS
11. CONTROLLING OFFICE NAME AND ADDRESS		12. REPORT DATE
		13. NUMBER OF PAGES
14. MONITORING AGENCY NAME & ADDRESS (if different from Controlling Office)		15. SECURITY CLASS. (of this report)
		15a. DECLASSIFICATION/DOWNGRADING SCHEDULE
16. DISTRIBUTION STATEMENT (of this Report)		
17. DISTRIBUTION STATEMENT (of the abstract entered in Block 20, if different from Report)		
18. SUPPLEMENTARY NOTES		
19. KEY WORDS (Continue on reverse side if necessary and identify by block number)		
20. ABSTRACT (Continue on reverse side if necessary and identify by block number)		

JOB SATISFACTION: LITERATURE REVIEW
AND EMPIRICAL TEST OF A JOB
FACET SATISFACTIONS MODEL

THESIS

AFIT/GSM/SM/79S-14

Terry R. Talbot
Captain USAF

Approved for public release; distribution unlimited.

79 11 05 341

AFIT/GSM/SM/79S-14

JOB SATISFACTION: LITERATURE REVIEW AND EMPIRICAL
TEST OF A JOB FACET SATISFACTIONS MODEL

THESIS

Presented to the Faculty of the School of Engineering
of the Air Force Institute of Technology
Air University (ATC)
in Partial Fulfillment of the
Requirements for the Degree of
Master of Science

by

Terry R. Talbot, B.S.

Captain USAF

Graduate Systems Management

September 1979

Approved for public release; distribution unlimited.

Preface

This thesis represents part of my efforts to earn a Master's degree in Systems Management from the Air Force Institute of Technology. I hope that, in some small way, it has added to the knowledge of job satisfaction.

I would like to thank my thesis advisor, Lt Col Edward J. Dunne, Jr., for his guidance throughout this research effort. Thanks are also due Capt Michael Stahl and Lt Col Charles McNichols for their assistance with the many questions I presented them while I was putting this thesis together.

Finally, my thanks to my wife, Bettie, and daughter, Shelly, for their patience with my fits of temper when things were not going well and their understanding during the long periods when my mind was far away, pondering some aspect of job satisfaction.

Terry R. Talbot

Accession For	
NTIS GAMA	<input checked="" type="checkbox"/>
DIC TAB	<input type="checkbox"/>
Unannounced	
Justification	
By _____	
Distribution/	
Availability Codes	
Dist	Avail and/or special
A	

Contents

	Page
Preface	ii
List of Figures	v
List of Tables	vi
Abstract	viii
I. Introduction	1
Background	1
Purpose of This Study	5
Limitations	8
II. Literature Review: The Nature and Causes of Job Satisfaction	9
Definitions of Terms	9
Outcomes and Rewards	9
Intrinsic versus Extrinsic Outcomes	10
Job Satisfaction	11
Need Fulfillment Theories	13
Maslow's Need Hierarchy Theory	15
Alderfer's Existence, Relatedness, and Growth Theory	17
Implications of the Need Hierarchy Theories	17
Achievement Motivation Theory	19
Motivation-Hygiene Theory	22
Expectancy Theory	27
Job Characteristics Theories	32
Requisite Task Attributes	33
Core Characteristics and Higher Order Need Strengths	34
The Job Characteristics Model	35
Discrepancy Theory	36
Equity Theory	40
Lawler's Model of Facet Satisfaction	44
Clustering of Facet Satisfaction	47
Summary	54
III. The Empirical Study	58
The Questionnaire	58
Strengths of Outcomes	59
Minnesota Satisfaction Questionnaire	61
Hoppock Job Satisfaction Blank	64
Demographics	66
The Sample	66
Demographics Breakdown	69
Limitations of the Sample	70

Contents

	Page
Development of the Hypotheses	71
Job Satisfaction and Age, Longevity, and Rank	71
Job Satisfaction and Education Level	75
Job Satisfaction and Aeronautical Rating	76
The Three Cluster Model of Facet Satisfaction	79
Clustering of Outcomes and Facet Satisfaction	81
Relative Importance of Facet Satisfaction Clusters	90
IV. Data Analysis Results	93
Data Related to the First Hypothesis	93
Data Related to the Second Hypothesis	96
Data Related to the Third Hypothesis	97
Data Related to the Fourth Hypothesis	100
Data Related to the Fifth Hypothesis	106
Data Related to the Sixth Hypothesis	112
V. Summary and Conclusions	117
Findings Related to the Major Hypotheses	117
Conclusions of the Study	121
Implications for Job Design	123
Areas for Future Research	123
Bibliography	125
Appendix A: Survey Instrument	132
Appendix B: Authorization to Reproduce the Minnesota Satisfaction Questionnaire	155
Appendix C: Factor Structures and Reliability Coefficients for MSQ and Hoppock Scales	158
Appendix D: Demographic Distributions of the Sample	162
Appendix E: Tabulated Data Analysis Results	167
Vita	173

List of Figures

<u>Figure</u>	<u>Page</u>
1 Simplified Need Fulfillment Model	13
2 Maslow's Hierarchy of Needs	16
3 Comparison of Maslow and ERG Concepts	18
4 Diagram of the Two Basic Need Systems	23
5 Model of the Relationship of Performance to Satisfaction	32
6 The Job Characteristics Model of Work Motivation	35
7 Lawler Model of Facet Satisfactions	46
8 The Loci of Facet Satisfactions	52
9 Job Satisfaction Portion of Dasplet's Comprehensive Model of Work Motivation	80
10 Scree Test for Retaining Factors: Plot of Seven Hypothetical Factors	86
11 Logical Sequence of the ACLUS Algorithm	88
12 Scree Test for Dimensionality of Objective Outcome Strengths	100
13 ACLUS Dendogram Showing the Clustering of Objective Outcome Strengths	104
14 Scree Test for Dimensionality of MSQ Facet Satisfactions	106
15 ACLUS Dendogram Showing the Clustering of MSQ Facet Satisfactions	111

List of Tables

<u>Table</u>	<u>Page</u>
I MSQ Facet Scales and Representative Items	62
II Proposed Association Between Work System Features and Psychological States	82
III Predicted Grouping of Strengths of Outcomes	84
IV Predicted Grouping of Facet Satisfaction	89
V First-order Partial Correlations, Controlling for Education Level	94
VI Third-order Partial Correlations, Controlling for Age, Longevity, Rank	96
VII T-tests Comparing Satisfaction Factors of Rated and Non-rated Officers	98
VIII One-way Analysis of Variance Comparing Satisfaction Factors of Pilots, Navigators, and Non-rated Officers	99
IX QUARTIMAX Rotated Factor Structure Matrix for Objective Outcome Strengths	102
X VARIMAX Rotated Factor Structure Matrix for MSQ Facet Satisfaction	108
XI Multiple Regression of Factor Scores with Overall Satisfaction	113
XII Tests of Differences in Magnitudes of Beta Coefficients	115
XIII Zero-order Correlations of MSQ Facet Satisfaction Scores with Hoppock Scores	116
C-I Factor Structures and Reliability Coefficients for MSQ and Hoppock Scales	159
D-I Age of the Respondents	163
D-II Sex of the Respondents	163
D-III Marital Status of the Respondents	164
D-IV Rank of the Respondents	164
D-V Length of Military Service of the Respondents	165

List of Tables

<u>Table</u>	<u>Page</u>
D-VI Aeronautical Ratings of Respondents	165
D-VII Job Level of Respondents	166
D-VIII Education Level of Respondents	166
E-I T-tests Comparing Satisfaction Factors of Pilots and Navigators	168
E-II T-tests Comparing Satisfaction Factors of Pilots and Non-rated Officers	169
E-III T-tests Comparing Satisfaction Factors of Navigators and Non-rated Officers	170
E-IV Clustering Summary: Objective Outcome Strengths	171
E-V Clustering Summary: MSQ Facet Satisfactions	172

Abstract

The broad objective of this study was to examine the nature and causes of job satisfaction. This was pursued through a literature review of the more popular theories and models pertaining to job satisfaction. Included in the review are summaries of Maslow's and Alderfer's need hierarchy theories, achievement motivation theory, Herzberg's motivation-hygiene theory, expectancy theory, job characteristics theories, discrepancy theory, equity theory, and studies relating to the clustering of facet satisfactions.

The specific objective of this research was to test the efficacy of a three cluster model of facet satisfactions. This was accomplished through a survey which was completed by 267 Air Force officers attending Squadron Officer School and Air Command and Staff College.

Conclusions reached by the study were that for Air Force officers in the ranks of captain and major:

1. Job satisfaction is higher for older officers who have more time in the service.
2. There is no evidence of a relationship between education level and job satisfaction.
3. Non-rated officers are more satisfied with their jobs than rated officers.
4. Work environment facet satisfactions are interpreted by employees to form three clusters: job properties, interaction features, and organization policy variables.
5. The three clusters of facet satisfactions vary in importance to overall job satisfaction with job properties being most important and organization policies being least important.

JOB SATISFACTION: LITERATURE REVIEW AND EMPIRICAL
TEST OF A JOB FACET SATISFACTIONS MODEL

I Introduction

In our quest for a better environment, we must always remember that the most important part of the quality of life is the quality of work, and the new need for job satisfaction is the key to the quality of work.

President Richard M. Nixon
Labor Day Address
September 6, 1971

Background

Job satisfaction probably has received more attention than any other aspect of industrial psychology. In 1976 Locke conservatively estimated the number of published articles and dissertations on the subject of job satisfaction to be at least 3,350 (Locke, 1976:1297). Since then, of course, a great many more studies have been published. Consideration of the amount of effort expended on the study of job satisfaction immediately brings to mind the question: "What is it that makes job satisfaction so important?" A very brief historical note provides the answer.

During the early part of this century, the scientific management theory proposed by Frederick W. Taylor (1911) dominated the study of work behavior. This theory implicitly assumed that workers who received the highest possible earnings with the least amount of fatigue would be satisfied and productive (Locke, 1976:1298). Consequently, the majority of research was conducted on physical working conditions and the effects of rest periods.

In the 1920's Elton Mayo and his associates conducted extensive studies at the Hawthorne plant of the Western Electric Company in Cicero, Illinois (Roethlisberger and Dixon, 1939). These now famous "Hawthorne studies" began with the scientific management type research question: What is the effect of illumination on productivity? However, when the workers failed to respond in any consistent manner, the Hawthorne researchers shifted their emphasis to the study of worker attitudes. After years of study, the researchers arrived at the (then) radical conclusions that workers have feelings which affect their work behavior and that the way workers perceive objective reality may be more important in understanding behavior than the facts of objective reality (Landy and Trumbo, 1976:341). This marked the beginning of what has become known as the "human relations" school of management which has generated intense interest in job satisfaction.

The human relations school of thought de-emphasized the importance of economic rewards in favor of the social aspects of the work environment. The roles of the informal work group and supervisory practices in workers' contentment became the central issues in organizational behavior. The function of the industrial psychologist was seen as improving the happiness of the worker. The implicit assumption was that the satisfied worker produces more (Gruneberg, 1976:x). "In fact human relations might be described as an attempt to increase productivity by satisfying the needs of employees" (Vroom, 1964:181).

Through the 1930's and 1940's the human relations school dominated the field of industrial psychology. Consequently, many studies during that time were predicated on the assumption that high job satisfaction led to effective job performance. Most individual studies failed to

support this tenet, but it was not until 1955 when Brayfield and Crockett published a systematic review of the empirical data that the assumption was finally laid to rest (Porter and Lawler, 1968:121-2).

The most recent school of management thought is referred to by many as the "human resources" model. This philosophy views humans as being motivated and satisfied by a complex set of interrelated factors which stem from numerous wants, desires, and needs. Basic to the human resources school are several assumptions about the nature of people. First, it is assumed that people want to contribute on the job. Second, it is assumed that many kinds of work are actually enjoyable. Jobs which are high in variety, autonomy, responsibility, and so on, are seen as being meaningful and leading to high motivation. Third, the model asserts that employees are capable of making significant and rational decisions concerning their work and that the organization is best served by allowing employees to have more latitude in decision making. Finally, it is assumed that by allowing employees to have more self-control in their work and by providing more meaningful tasks, the level of job satisfaction will be increased (Steers and Porter, 1975:17-20).

It is apparent from the assumptions listed above that the human resources school sees people as being internally motivated by jobs which provide them opportunities to make significant contributions. The model further asserts that the same factors which lead to high motivation and performance also lead to high job satisfaction. However, there is no assertion that the more satisfied worker necessarily will be more productive.

Even though researchers now generally agree that job satisfaction is not the cause of high performance, the relationship between satisfaction

and performance continues to be of interest. Lawler and Porter (1967; Porter and Lawler, 1968) have suggested that the direction of causation is from performance to satisfaction. In other words, high performance leads to job satisfaction. This view has received moderate empirical support. However, the most salient conclusion reached by many researchers is that the satisfaction-performance relationship is more complex than one causes the other and yet it is not understood (Greene, 1972; Vroom, 1964:186).

During the last 30 years job satisfaction research has broadened into many areas of employee attitudes and the work environment. Usually the studies have not been theoretically oriented, but have been correlational type investigations of job satisfaction with factors such as age, sex, education, job level, absenteeism, etc. These more recent studies indicate that organizational psychologists are now studying job satisfaction not as a purely economic concern of industry, but simply because they are interested in finding its nature and causes. This approach is congruent with the recent interest in the quality of life since job satisfaction is generally accepted as being a critical factor in the quality of working life. "What happens to people during the work day has profound effects both on the individual employee's life and on society as a whole, and thus these events cannot be ignored if the quality of life in a society is to be high" (Lawler, 1973:63).

An extensive government study conducted during the early 1970's concluded: "Because work is central to the lives of so many Americans, either the absence of work or employment in meaningless work is creating an increasingly intolerable situation" (Special Task Force, H.E.W., 1973:186). The Task Force report suggests repeatedly that the way to

combat meaningless work is to redesign jobs to increase workers' job satisfaction. "The main conclusion is that the very high personal and social costs of unsatisfying work should be avoided through the redesign of work" (Special Task Force, H.E.W., 1973:94; emphasis in the original).

In addition to the importance job satisfaction plays in the overall quality of life, many specific factors have been shown to be related to job satisfaction. Numerous studies have concluded that job satisfaction influences absenteeism and turnover (Dachler and Schneider, 1978; Lawler, 1970:225; Porter and Steers, 1973; Smith 1977; Steers and Rhodes, 1978; Vroom, 1964:175-8). Many researchers have found job satisfaction to be significantly correlated with such varied outcomes as life satisfaction, self-esteem, depression, psychosomatic illness symptoms, work-related fatigue, work-related accident rates, physiological disfunctions like ulcers and heart disease, work-related use of narcotic drugs, and on-the-job destructive behavior such as theft and sabotage (Landy and Trumbo, 1976:359-62; Locke, 1976:1328-34; Seashore and Taber, 1975:359-60; Vroom, 1964:175-87). It is obvious from this list that the motivation to study job satisfaction is still very strong.

Purpose of this Study (Daspit, 1978:70-92)

This research is a follow-up to a thesis written by Captain Paul Daspit, Air Force Institute of Technology section GSM-78S. Captain Daspit performed an extensive literature search and integrated the popular contemporary theories of work motivation into a comprehensive work motivation model. The purpose of this research is to more deeply investigate one aspect of Daspit's model and to empirically test that part of the model.

Daspit's model is patterned after the expectancy model proposed by

Porter and Lawler (1968); however Daspit expanded the model significantly to account for the motivational factors explained by the various other theories.

This research will focus on one specific area of Daspit's model: the work environment facet satisfactions. Daspit based his model on the premise that there are two levels of job satisfaction: facet satisfaction and overall satisfaction. The overall satisfaction is a weighted sum or product or some other aggregation of the facet satisfactions resulting from different aspects of the work. Examples of facet satisfactions are satisfaction with pay, working conditions, status, and autonomy. As the examples demonstrate, facet satisfactions result from job performance related outcomes as well as organization membership related situations.

Based on research by Katz and Van Maanen (1977), Daspit further divided the work environment facet satisfactions into three segments: job property, interaction features, and organization policies. Job property satisfactions, the first segment, are intrinsic to the individual; that is they are administered by the individual to himself. The interaction feature and organization policy satisfactions are extrinsic to the individual; they are awarded to the individual by the organization or other external agent.

The three clusters of facet satisfactions are the result of identically clustered job outcomes which are mediated through psychological states. For example, the job property outcomes such as task variety, challenging work, responsibility, and autonomy lead to the psychological states of experienced task meaningfulness, experienced task responsibility, and experienced job/task challenge and variety. These psychological states in turn lead to the facet job property satisfactions. The level of satisfaction is determined by the individual's perceptions of the equitableness,

or fairness, of the outcomes received. Simply stated, job outcomes as experienced (or perceived) by the individual result in job satisfaction to the extent that the individual perceives the outcomes to be equitable.

The three clusters of outcomes which lead to facet satisfactions are:

- Job Properties** - Task Variety
Challenging Work
Responsibility
Creativity
Achievement of Internalized Goals
Independence (Autonomy)
Ability Utilization
Task Significance
Performance Feedback (from the work itself)
Closure or Completeness of the Job
- Interaction Features** - Participation
Performance Feedback (from clients, co-workers or supervisors)
Colleague Assistance
Supervision
Recognition (from clients, co-workers or supervisors)
Other Workgroup Relations
- Organization Policy** - Compensation (amount, equity and practices)
Promotion (fairness and opportunity)
Advancement
Training
Fringe Benefits
Hiring and Staffing

Based on the preceding discussion, the broad objective of this study is to investigate the nature and causes of job satisfaction. This objective is pursued primarily through the literature review which follows in Chapter II. The specific subobjectives of this study are to gather data and test six hypotheses relating to job satisfaction. Several fairly standard hypotheses are examined, but the primary emphasis of this study is on testing Daspit's three cluster model of facet satisfaction. Since detailed theoretical development of each hypothesis is in Chapter III, they are simply listed here.

- H1: Job satisfaction increases with age, longevity, and rank.
- H2: Job satisfaction decreases with education level.
- H3: Job satisfaction differs with aeronautical rating.
- H4: Objective work environment outcomes are interpreted by employees to form three clusters: job properties, interaction features, and organization policy variables.
- H5: Work environment facet satisfactions are interpreted by employees to form three clusters: job properties, interaction features, and organization policy variables.
- H6: The three clusters of facet satisfactions vary in importance to overall job satisfaction with job properties being most important and organization policies least important.

Limitations

The limitations to this study are the following:

- (1) The study is limited by the extent of the literature review.

Due to the voluminous amount of data on job satisfaction, total coverage is impossible. The more popular theories of the nature and causes of job satisfaction are covered thoroughly.

- (2) The study is limited by the sample selected for the empirical test. The sample consists of a randomly selected portion of the students in a Squadron Officer School class and an Air Command and Staff College class. The Squadron Officer School sample is representative of Air Force junior officers. However, the Air Command and Staff College sample represents a select few of the more "successful" senior captains and majors in the Air Force. The generalizability of the results of the hypotheses tests is limited to the portion of Air Force officers represented by the sample.

The next chapter contains a review of the literature relating to job satisfaction.

II Literature Review: The Nature and Causes of Job Satisfaction

As mentioned in the previous chapter, much of the research on job satisfaction has not been based on strong theoretical statements. In fact, almost all the theory available on job satisfaction is the result of theoretical studies on worker motivation. In many of the motivation theories, satisfaction is an explicit outcome of designing the job to motivate the employees. In other theories satisfaction implicitly follows from need fulfillment or the satisfaction of primary drives.

Prior to the literature review, a section is devoted to defining several of the terms used throughout this thesis.

Definitions of Terms

Definitions of job satisfaction vary from the very simple "a feeling which develops when you approach or anticipate approaching the job" (Landy and Trumbo, 1976:361) to many paragraphs (or a chapter) filled with complex psychological concepts. This section presents definitions of several terms related to job satisfaction study, and a working definition of job satisfaction itself.

Outcomes and Rewards. A job outcome is an object received or an event perceived by an individual which results from some facet of the work situation. This is a very broad term. Outcomes can be material objects awarded by the employer such as money; non-material items awarded by the employer such as rank; responses from interaction with co-workers or clients; or internal "feelings" resulting from some aspect of the job, for example, feelings of accomplishment or frustration. Outcomes can be either valued or disvalued by the individual; for example, a rodeo cowboy most likely values the pay and prestige that come from winning the bull

riding event, but he surely disvalues a broken arm which is also a possible outcome of that event.

Rewards are the desirable outcomes that result from the job or work situation. The concept of rewards has received a great deal of attention from researchers--one study systematically identified and categorized 1500 job rewards (Pritchard and Shaw, 1978). Often, when discussing job satisfaction, the term rewards is used almost exclusively. It should be kept in mind, however, that the presence of disvalued outcomes is very important to considerations of overall job satisfaction.

Intrinsic versus Extrinsic Outcomes. A major distinction which has received widespread attention from researchers is the intrinsic-extrinsic dichotomy. This distinction has been used in describing such things as outcomes, motivations, values, and satisfactions. Additionally, researchers have used the intrinsic-extrinsic differentiation when referring to individual traits or states, when characterizing the work environment, and when describing individual behavior (Broedling, 1977). The usage has become so diverse that considerable confusion has resulted among psychologists as to the definitions of the terms and appropriate classification of particular outcomes into intrinsic and extrinsic categories (Dyer and Parker, 1975). In an effort to allay the confusion, Brief and Aldag presented the following definitions:

An intrinsic work outcome is an object or event received or experienced by a worker during or following the completion of a set of task behaviors which is self- or task-mediated in that the involvement of a source external to the task-person situation is not required for delivery to take place...

An extrinsic work outcome is an object or event received or experienced by a worker following the completion of a set of task behaviors which

is dependent on a source external to the immediate task-person situation for delivery to take place (Brief and Aldag, 1977:497-8).

The operative part of these definitions is "source external to the task-person situation." This term refers to "all environmental elements other than the worker and the object or objects being processed by the worker" (Brief and Aldag, 1977:497). The intrinsic-extrinsic distinction is extremely important in several theories of job satisfaction.

Job Satisfaction. As mentioned above, the definitions of job satisfaction vary from the simple to the complex. Based upon the foregoing discussion of job outcomes and rewards, it is logical to begin by defining facet satisfactions.

Given that a job or work situation has a number of possible outcomes, it follows that each outcome has the propensity to lead to satisfaction or dissatisfaction. This leads to the concept of facet satisfactions: an individual's affective response to the favorableness or unfavorableness of specific facets of the job, such as pay, autonomy, task variety, and co-worker interaction. The concept of (if not the specific term) facet satisfactions is a part of many theories of job satisfaction (cf. Hackman and Lawler, 1971; Hackman and Oldham, 1976; Herzberg, Mausner, and Snyderman, 1959; Kalleberg, 1977; Lawler, 1973:74+; Smith, Kendall, and Hulin, 1969; Vroom, 1964:102-3,279-80).

Overall job satisfaction can be formulated as some type of combination of facet satisfactions, for example, a weighted sum, average, or product. It should be noted, however, that the relationship between facet satisfactions and overall satisfaction is neither fully nor consistently explained by such mathematical relationships. Conceptually, positive facet satisfactions would lead to increased overall job satisfaction while

negative facet satisfactions would lead to decreased overall job satisfaction. However, not all facet satisfactions are necessarily weighted equally (Lawler, 1973:77-8; Wanous and Lawler, 1972).

Overall job satisfaction is, therefore, the overall affective orientation an individual has toward his or her work situation, the "pleasurable or positive emotional state resulting from the appraisal of one's job or job experiences" (Locke, 1976:1300).

It is important to note that this definition places individual perceptions in a preeminent position with respect to job satisfaction. An individual's affective reactions are based on perceptions; these perceptions may or may not accurately reflect reality (Porter, Lawler, and Hackman, 1975:24-5, 48-55).

It is worthwhile to explicitly address what job satisfaction is not. Sometimes the job attitudes of intrinsic motivation, involvement, and satisfaction are treated as being one and the same. Intrinsic motivation, however, relates to the affective force upon an employee to perform well because of some subjective rewards or feelings that he or she expects to receive or experience as a result of performing well (Lawler and Hall, 1970:306). Job or work involvement is the degree of psychological identification an individual has with his or her job or work organization. "Involvement may be thought of as the degree to which the job situation is central to the person and his identity" (Lawler and Hall, 1970:311). These attitudes may well be correlated with job satisfaction; however they are not the same (Cummings and Bigelow, 1976; Lawler and Hall, 1970).

The remainder of this chapter presents brief descriptions of several of the more popular theories and models of job satisfaction.

Need Fulfillment Theories

Many of the theories and models of job satisfaction (and motivation) are based on the concept that "job satisfaction will vary directly with the extent to which those needs of an individual which can be satisfied are actually satisfied" (Schaffer, 1953:3). As a matter of fact, some type of a need fulfillment model provides the theoretical framework for most concepts of job satisfaction.

Generally speaking, the basic need fulfillment model is simple. People are assumed to have needs, wants, or desires. The job is assumed to have a number of characteristics which provide outcomes. If the job incumbent perceives the job characteristics as fulfilling his or her needs, the result is satisfaction with the job. Figure 1 illustrates this simplified model.

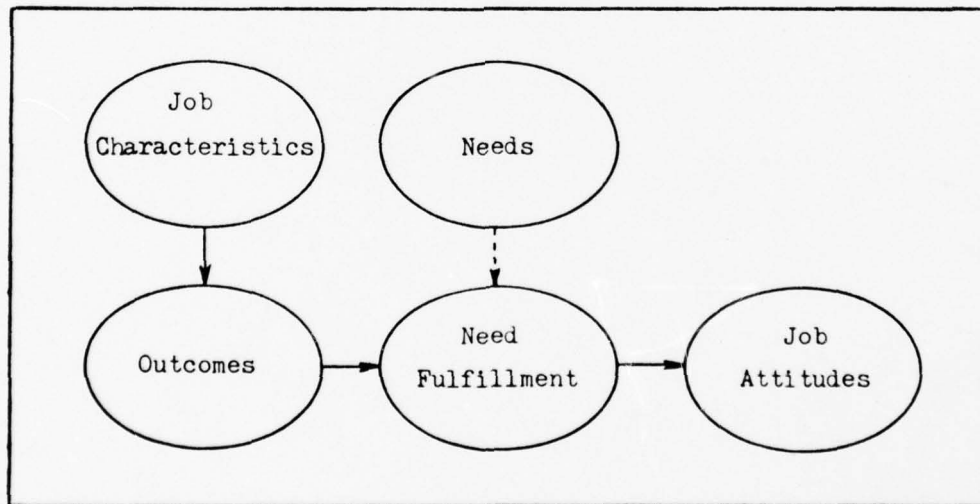

Figure 1. Simplified Need Fulfillment Model

Salancik and Pfeffer (1977) identify five general components of need fulfillment models.

1. There is an assumption of causality which begins with the job

and its characteristics. Job characteristics are considered the stimuli which lead to an attitude in the person.

2. Attitudes are conceived of as reactions by people to their environment. Authors differ about whether the reactions are affective or cognitive, and there are differences about how the resulting attitudes are manifested by individuals.

3. Needs are conceptualized as relatively stable characteristics of people. Many authors assert that need strengths change, for example, Alderfer (1972) and Maslow(1954). However, according to Salancik and Pfeffer, the underlying assumption in need fulfillment theories is that the needs themselves are fixed characteristics of individuals.

4. Need satisfaction models generally take job characteristics to be realities in the environment to which the individual responds. Some theorists speak of perceived job characteristics, but they do not propose that job characteristics are social constructions--that is, created in and for a particular social context.

5. The final component of need satisfaction models is the functional relationship of needs, job characteristics, and attitudes. Many theorists propose mathematical models to explain this functional relationship, several of which are presented later in this chapter.

The theories presented in the remainder of this section are based on the need fulfillment concept of job satisfaction. Some of these theories--specifically Maslow's need hierarchy theory and Existence, Relatedness, and Growth theory--simply identify the human needs which cause certain behaviors and attitudes. Herzberg's motivator-hygiene theory and the various job characteristics models offer prescriptions for designing jobs for maximum employee satisfaction and motivation. The final theory

reviewed in this section, expectancy theory, presents a detailed model of the process by which employees are motivated and become satisfied. In other words, expectancy theory describes how one decides to behave in order to fulfill needs and experience satisfaction.

Maslow's Need Hierarchy Theory. One of the older and more popular models of human behavior is Maslow's need hierarchy theory (Maslow, 1943; 1954; 1970). Maslow's theory is based on two fundamental premises. First, humans are seen as being motivated by a desire to satisfy certain types of needs. The theory asserts that people have five basic categories of needs:

1. Physiological needs, such as food, water, air;
2. Safety needs, such as freedom from harm;
3. Love or belongingness needs;
4. Esteem needs, including the need for mastery and achievement and the need for recognition and approval of others; and
5. Self-actualization need which is defined as "the desire to become more and more of what one is, to become everything that one is capable of becoming" (Maslow, 1954:91-2).

Maslow states that to the extent that a need is unsatisfied, tensions are produced within individuals which cause them to behave in manners which lead to satisfaction of the needs and consequent reduction of the tensions. Once a need is satisfied, it no longer produces tensions leading to behavior. In other words, "a satisfied need is not a motivator" (Maslow, 1954:105). The one exception to the increased satisfaction-decreased importance pattern is the self-actualization need. For this need increased satisfaction leads to increased need strength: "When we examine people who are predominantly growth-motivated . . . gratification breeds increased rather than decreased motivation, heightened rather than

lessened excitement" (Maslow, 1968:30).

The second premise fundamental to Maslow's theory is that the five needs are arranged in a hierarchy (from low to high as given above) such that the higher needs are not motivating until the lower needs are satisfied. This implies that for a given individual at a given time, one class of needs will be more salient than any other. Then, as those needs become satisfied, needs at the next higher level will become stronger. (Figure 2 shows a model of Maslow's hierarchy of needs.) This prepotency concept has a great deal of intuitive appeal, especially when referring to the lower level needs. Additionally, there is evidence from studies on starvation and thirst which strongly suggests that when the basic biological existence needs are not satisfied, higher order needs do not come into play (Keys, et al., 1950; Wolf, 1958).

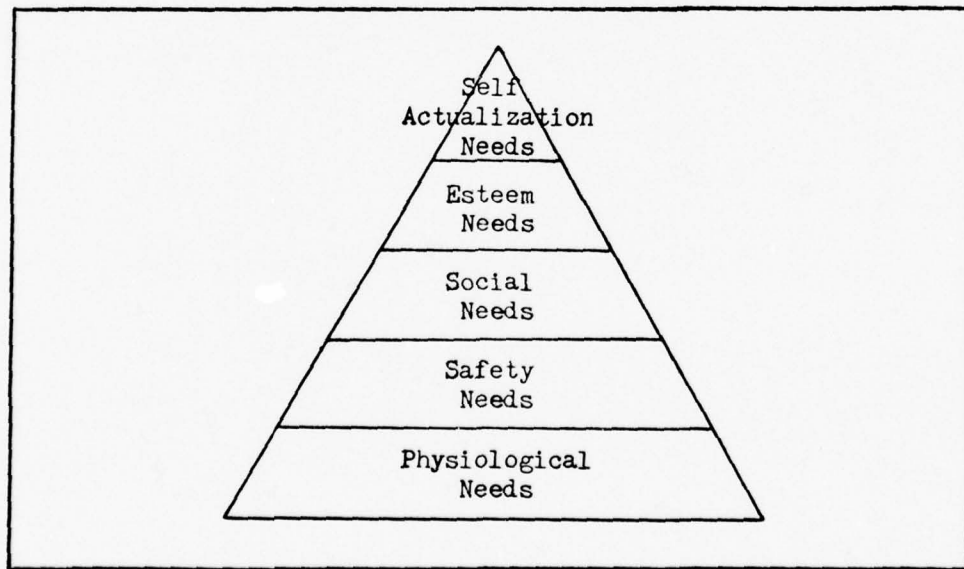

Figure 2. Maslow's Hierarchy of Needs

Maslow suggests that a hierarchy of needs is a universal characteristic of humans. However, he does specify that the five-step hierarchy

named in the theory is not a rigidly fixed order that is the same for all individuals. Especially in the case of needs in the middle of the hierarchy, the order may vary from person to person. Maslow further specifies that movement up the hierarchy is a long term affair. In fact, he speculates that the hierarchy may take an entire lifetime to unfold (Maslow, 1970:20).

Alderfer's Existence, Relatedness, and Growth Theory. A second need hierarchy theory which has received considerable attention is Alderfer's Existence, Relatedness, and Growth (ERG) theory. This theory proposes three rather than five needs:

1. Existence needs include all the physiological and material needs;
2. Relatedness needs are needs for relationships with significant other people; and
3. Growth needs are the needs which cause an individual to be creative or productive (Alderfer, 1972:10-1).

Alderfer asserts that these needs are arranged in a hierarchy (from low to high as given above) but he does not assign a prepotency to the needs as Maslow does. ERG theory allows for all needs to be motivating at the same time, and it allows for an individual to move up and down the hierarchy readily as needs are satisfied or frustrated.

Other than the number of basic needs and the prepotency of lower level needs, Alderfer's theory is very similar to Maslow's. The lower level needs are seen as decreasing in importance as they are satisfied, and like Maslow's self-actualization need, Alderfer's growth need becomes stronger as it is satisfied. Figure 3 shows the relationship of Alderfer's and Maslow's theories.

Implications of the Need Hierarchy Theories. Maslow's and Alderfer's

MASLOW CATEGORIES	ERG CATEGORIES
Physiological	Existence
Safety-Material	
Safety-Interpersonal	Relatedness
Love (Belongingness)	
Esteem-Interpersonal	
Esteem-Self-confirmed	Growth
Self-actualization	

Figure 3. Comparison of Maslow and ERG Concepts
(Alderfer, 1972:25)

need hierarchy theories are applied to job satisfaction by assuming that if outcomes from the job provide for fulfillment of the needs, the work situation will be a satisfying experience. The hierarchical concept has received a great deal of attention from organizational psychologists. If the concept is valid, it can provide a valuable tool for predicting what outcomes are likely to be important to employees. The hierarchy theories suggest, for example, that if people "have tenure" and their lower level needs are satisfied, they will be more concerned with self-actualization and growth. The theories further suggest that an organization can satisfy employees' lower level needs, such as security, but it can not provide enough growth and development to satisfy employees' higher order needs.

A number of empirical studies have been less than totally supportive of the need hierarchy theories presented here. In a five year longitudinal study, Hall and Nougaim (1968) found almost no support for Maslow's hypothesized hierarchy of needs. Specifically, their results were contrary to the theory's predictions that: (1) as a need is satisfied it ceases

to be important as a motivator, and (2) as a need is satisfied at one level, the next higher level need increases in importance. Lawler and Suttle (1972) suggest that there is little evidence to support more than a two-level hierarchy. They argue that the lower level is made up of biologically based needs (hunger, thirst, reproduction, physical safety, etc.) while all other needs are on the second level (Lawler and Suttle, 1972:285). Porter, Lawler, and Hackman take this concept one step further by stating, "It is safe to assume that unless the lower-order needs are satisfied the others will not come into play in any major way. However, which higher-order need or needs will become salient after the lower ones are satisfied (and the order in which they develop) cannot be stated" (Porter, Lawler, and Hackman, 1975:44).

One important application of the need theories in research is the association between need strengths and work values. Specifically, it appears that individuals high in the higher-order (or growth) needs are more satisfied by jobs which provide intrinsic rewards, that is jobs high in autonomy, variety, challenge, responsibility, and significance (Hackman and Lawler, 1971; Hackman and Oldham, 1976; Porter and Steers, 1973).

Achievement Motivation Theory. Achievement motivation theory is, as the name states, a motivation theory. However, like Maslow's and Alderfer's theories, it is a need theory which implies that if the proper needs are satisfied, the individual will be satisfied.

Achievement motivation theory is based on a theory of personality developed in the 1930's by Murray (1938). Based on long term clinical observations, Murray and his associates proposed that an individual's personality is formed by many divergent needs. These needs can be divided into two broad classes: viscerogenic needs which are biologically based

and have to do with physical satisfactions, and psychogenic needs which are psychologically based and associated with mental or emotional satisfactions. Among the psychogenic needs that Murray identified are the needs for achievement, affiliation, power, autonomy, recognition, aggression, and deference. The model further posits that the individual needs can be either manifest or latent. Latent needs may be quite strong, but for some reason they have been inhibited and consequently have not found an overt form of expression. This means that a person might have a strong need for achievement, but due to some impediments in the environment (such as the lack of a challenging task) the need has not been strongly aroused. Another important aspect of Murray's theory is that the psychogenic needs are viewed as largely being learned, rather than innate characteristics of the human animal. This concept has been important in the more recent developments of the theory. In fact, McClelland (1965; 1966) has developed a program to teach people to have a strong need for achievement.

The more recent studies which have led to the achievement motivation theory have focused primarily on the need for achievement (n Ach). Need for achievement represents an experienced need to accomplish something important or compete with a standard of excellence. The basis or reward for this type of behavior is posited to be the satisfaction associated with successful performance (McClelland, 1961:43).

Litwin and Stringer (1975) summarized the characteristics of an individual high in n Ach as follows:

1. Individuals high in n Ach like situations in which they take personal responsibility for finding solutions to problems.
2. Another characteristic of individuals with a strong achievement concern is their tendency to set moderate goals and to take calculated

risks.

3. People with strong concern for achievement also want concrete feedback as to how well they are doing (Litwin and Stringer, 1975:53-5).

The implications of the achievement need theory for job design are obvious. The theory predicts that, for employees high in n Ach, enriching a job by providing more responsibility, challenge, and feedback will lead to increased performance, involvement, and satisfaction. On the other hand, enriching the job of an individual who is low in n Ach will have no impact on performance and could lead to frustration, anxiety, and job dissatisfaction.

Several aspects of the achievement motivation theory have been examined in empirical studies. The theory's prediction of the job scope-job performance relationship has received some support. In a study of 115 managers in various departments of a major manufacturing firm, Steers and Spencer (1977) found that increases in job scope were associated with increased job performance for high n Ach employees, but not for low n Ach ones. However, support for the theorized effect of n Ach on the job scope-job satisfaction relationship has been mixed. In a study of 454 workers and supervisors in 3 different manufacturing firms, Stinson and Johnson (1977) found considerable moderating effect of n Ach in satisfaction with task structure and autonomy. On the other hand, Steers (1975; 1976) in a study of 133 female first-line supervisors in a large public utility company, found that need strengths had no effect on job satisfaction. Similarly, Stone, Mowday, and Porter (1977), studying 340 employees at all levels of a large manufacturing firm, found n Ach to be of no practical importance as a moderator in the job scope-job satisfaction relationship. Interestingly, however, they did find n Ach to be very important as an

independent predictor of job satisfaction. Further, Steers (1975) reported that n Ach was a significant moderator in the job performance-job satisfaction relationship. The confused, sometimes contradictory, nature of these reported results indicates that more study is needed.

The achievement motivation theory has received criticism in several areas. First, the model is seen to place too much emphasis on one variable (n Ach). Some researchers contend that more complex analyses are needed to take a more comprehensive approach to the issues of motivation and satisfaction. A second criticism is that with few exceptions the n Ach model has been studied only under laboratory conditions. More field testing is needed before the applicability of the theory can be firmly established. Finally, the model does not make specific managerial recommendations for employees with low n Ach (Steers and Mowday, 1977:650-1). Despite these criticisms, however, achievement motivation theory has received fairly consistent support in predicting individual reactions to task design.

Motivation-Hygiene Theory. The motivation-hygiene theory, also called the two-factor or the dual-factor theory, is without a doubt the most controversial theory in industrial psychology. Numerous research efforts have been based on attempting to support or refute the theory. A summary of some of this research follows the review of the theory.

The motivation-hygiene theory is based on the results of 203 "semi-structured interviews" with accountants and engineers in the Pittsburgh area (Herzberg, Mausner, and Snyderman, 1959). The subjects were asked to identify periods in their own histories when feelings about their jobs were unquestionably higher or lower than usual. The subjects were also asked to describe how their attitudes affected their behavior during these

high and low feelings. The contents of the interviews were then analyzed and coded as to what type of events led to what type of attitudes and behaviors.

The resulting theory states that the factors involved in producing job satisfaction--and motivation--are separate and distinct from the factors which lead to job dissatisfaction. A corollary of this view is that the opposite of job satisfaction is not job dissatisfaction, but no job satisfaction. In other words, job satisfaction-dissatisfaction is not a continuum but rather two separate attitudes.

Herzberg and his associates argue that job satisfaction and dissatisfaction should be viewed as separate constructs because they result from separate human needs. One set of needs stems from the human's animal nature. The drive to avoid pain from the environment plus all the learned drives which become conditioned to meet the basic biological needs make up this first set, called hygiene needs. The other set, called motivator needs, results from the ability to achieve and, through achievement, to experience psychological growth. Figure 4 presents this aspect of the theory.

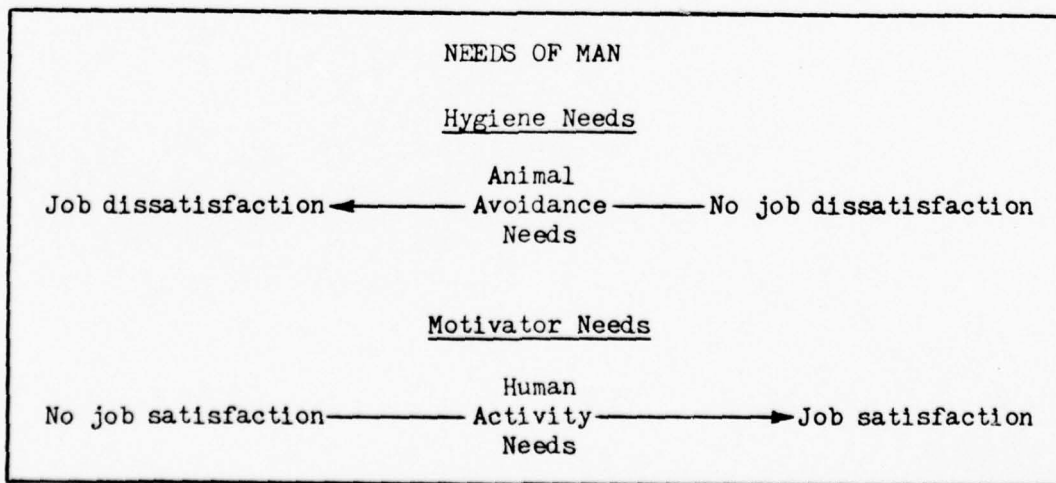

Figure 4. Diagram of the Two Basic Need Systems (Herzberg, 1976:84)

The motivation-hygiene theory goes on to specify the outcomes which lead to satisfaction of the two basic need sets. The stimuli for fulfillment of the animal avoidance needs are found in the job environment and designated "hygienes". The hygiene factors are company policy and administration, supervision, interpersonal relationships, working conditions, salary, status, and security. The stimuli for fulfillment of the growth needs are found in the job content and designated "motivators". The motivator factors are achievement, recognition for achievement, the work itself, responsibility, growth, and advancement.

The explicit implication of the preceding is that if the work and work environment are such that hygiene needs are not met, the employee will be dissatisfied; however meeting hygiene needs will not lead to satisfaction. Also, if motivator needs are met, the employee will be satisfied; however not meeting motivator needs will not lead to dissatisfaction, only a lack of satisfaction (Herzberg, Mausner, and Snyderman, 1959:113-9).

The use of the term "motivator" for those factors which can lead to satisfaction is indication of this theory's very specific tie between satisfaction and motivation. "It should be understood that both kinds of factors meet the needs of the employees; but it is primarily the 'motivators' that serve to bring about the kind of job satisfaction and . . . the kind of improvement in performance that industry is seeking from its work force" (Herzberg, Mausner, and Snyderman, 1959:114).

An important aspect of the theory is that it leads to a clear prescription for job design. Specifically, the theory asserts that a job will enhance positive work motivation and employee satisfaction to the extent that it provides opportunities for employees to achieve, to gain

recognition and responsibility, to advance in the organization, and to grow in competence (Herzberg, 1968). Since this theory and its resulting paradigm for job design are relatively simple and straightforward, they have become very popular with managers who are concerned with the problems of human behavior. As the following paragraphs demonstrate, however, the theory appears to be less popular with organizational researchers.

The motivation-hygiene theory has stimulated a great deal of research, much of which has not been supportive. For example, Dunnette, Campbell, and Hakel (1967), Stahl, Young, and Scoville (1977), and Wernimont (1966) have shown that the factors which produce job satisfaction are not separate and distinct from the factors that lead to job dissatisfaction. King (1970) pointed out that the motivation-hygiene theory could be interpreted in at least five different ways. After an extensive review of the relevant literature, King concluded that there was no clear support for the validity of any of the five versions.

On the other hand, a number of studies have been supportive of the theory. Herzberg (1966) reviews the results of 10 different studies of 17 different populations. He states that these studies support the motivation-hygiene theory in 97 percent of the cases. Unfortunately, though, the supportive studies used the critical-incident storytelling method that Herzberg and his associates used. This leads to the first major criticism of the theory--that it is methodologically bound (Dunnette, Campbell, and Hakel, 1967; King, 1970; Locke, 1976). Vroom (1964) argues that the results of the critical-incident method may be distorted by defensive processes within the individual respondents. "Persons may be more likely to attribute the cause of satisfaction to their own achievements and accomplishments on the job. On the other hand, they may be

more likely to attribute their dissatisfaction, not to personal inadequacies or deficiencies, but to factors in the work environment, i.e., obstacles presented by company policies or supervision" (Vroom, 1964:129).

A second major criticism of the theory is that the research upon which the theory is based is fraught with procedural deficiencies. Specifically, the coding of interview responses is not completely determined by the rating system and the data, but requires interpretation by the researchers. This necessity for interpretations of the data by a rater may lead to contamination of the coded data. In other words, the dimensions derived from the stories might reflect the raters' hypothesis rather than the respondents' perceptions (House and Wigdor, 1967).

A third major criticism is that the motivation-hygiene theory is inconsistent with other evidence. If the theory is correct, satisfaction produces higher motivation which in turn leads to improved performance. As previously mentioned, an exhaustive review of the literature by Brayfield and Crockett (1955) concluded that satisfaction does not lead to strong motivation for good performance. Vroom (1964) reviewed 20 studies which correlated one or more measures of job satisfaction with performance. Seventeen of the studies showed a positive relationship (however the median correlation was only .14) and three studies showed a negative relationship. In Herzberg's own literature review, he found that "in 54 percent of the reported surveys high morale (satisfaction) was associated with high productivity; in 35 percent morale and productivity were not found to be related; in 11 percent high morale was associated with low productivity" (Herzberg, Mausner, Perterson, and Capwell, 1957:103). Further, as Friedlander (1966:143) pointed out, the basis of the satisfaction-motivation relationship in the theory is

respondents self-reports of improved performance when satisfied. There is no evidence presented to support the validity of these self-reports.

Finally, the theory is criticized for ignoring individual differences and simply asserting that workers will be more satisfied if they have jobs high in motivators. To put it another way, the theory presupposes that all workers will respond favorably to "enriched" jobs. There is, however, considerable evidence that not all workers desire jobs which are high in motivators (Hulin and Blood, 1968; Stinson and Johnson, 1977; Turner and Lawrence, 1965). Many authors stress that the characteristics of individual workers must be considered if the impact of job design on the affective and behavioral responses is to be a good one (Porter, Lawler, and Hackman, 1975:300; Wanous, 1977).

In spite of the many severe criticisms of Herzberg's theory, through it he has made a major contribution to the knowledge of the nature of job satisfaction. This contribution stems from his stress on the importance of psychological growth in job satisfaction and the importance of the difference between intrinsic and extrinsic factors. The research which has been spurred by the motivation-hygiene theory has resulted in a much better understanding of the variables relating to job satisfaction and how to measure them (Landy and Trumbo, 1976:350).

Expectancy Theory. Campbell, Dunnette, Lawler, and Weick (1970) observed that theories of motivation (and satisfaction) have tended to divide themselves into two groups which they labeled (1) process theories and (2) content theories. Process theories first define the major classes of variables that are important, for example, needs, rewards, and perceptions, and then attempt to specify how those variables interact to produce certain kinds of behavior or response. Content theories, on the other

hand, are more concerned with the identification of what specific things it is within individuals and their environment that energize and sustain behavior or lead to responses by the individuals.

The theories presented thus far in this chapter are decidedly content theories, concerned with listing the specific needs which, when fulfilled, lead to satisfaction. The theory presented in this subsection is the epitome of a process theory. The emphasis is on the interaction of the major variables that lead to satisfaction and the process through which individuals choose what their behavior will be.

Expectancy theory had its beginnings when Tolman (1932) and Lewin (1935) began proposing cognitively oriented theories of human motivation with concepts of expectations, valences, and motivating force. The first complete treatment of expectancy theory with regard to the work environment was developed by Victor Vroom (1964). Vroom presented an extremely thorough theory of satisfaction and motivation which has gained wide acceptance by organizational psychologists. The theory consists of two models, referred to by some as the valence model and the behavioral choice model (Mitchell, 1974:1053-4). Job satisfaction is described by the valence model, so it receives most of the attention in this review.

Valence is defined as an individual's affective orientation toward particular outcomes. Basically, there are two reasons why outcomes may be valent: (1) they directly satisfy a person's needs, or (2) they lead to an outcome or set of outcomes that satisfy a particular need or set of needs (Lawler, 1973:51). In Vroom's model valence is assigned a numerical value ranging from -1 to +1. If a person would prefer having a certain outcome to not having it, that outcome is positively valent. If the preference is in favor of not having the outcome to having it, that

outcome is negatively valent. If an individual is indifferent to a given outcome, the valence of that outcome is zero. Valence is further distinguished from value: Valence refers to anticipated satisfaction associated with an outcome, whereas value refers to the actual satisfaction resulting from attaining the outcome (Vroom, 1964:15).

The valence model states that the valence of an outcome to a person is a function of the algebraic sum of the products of the valences of all other outcomes and the person's conceptions of the specific outcome's instrumentality for the attainment of these other outcomes:

$$v_j = f \left[\sum_{k=1}^n (v_k I_{jk}) \right]$$

where

$$v_j = \text{the valence of outcome } j$$

$$I_{jk} = \text{the instrumentality of outcome } j \text{ for the attainment of outcome } k$$

(Vroom, 1964:17)

Instrumentality is the degree to which the person sees the outcome in question as leading to the attainment of other outcomes. Instrumentality varies from -1 (when the perception is that outcome k is certain without outcome j and impossible with it) to +1 (outcome j is seen as necessary and sufficient for the attainment of outcome k).

Expectancy is defined as the belief concerning the likelihood that a particular act will be followed by a particular outcome. An expectancy of one indicates a subjective certainty that the act will be followed by the outcome while an expectancy of zero indicates subjective certainty that the act will not be followed by the outcome.

The behavioral choice model states that the force on a person to perform an act is a function of the algebraic sum of the product of the

valences of all outcomes and the strength of the person's expectancies that the act will be followed by the attainment of these outcomes:

$$F_i = f \left[\sum_{j=1}^n (E_{ij} V_j) \right]$$

where

F_i = the force to perform act i

E_{ij} = the strength of the expectancy that act i will be followed by outcome j

V_j = the valence of outcome j

(Vroom, 1964:18)

In terms of the valence model, Vroom proposed that job satisfaction could be viewed as the valence of a work situation to an individual. Since a job is made up of many outcomes, each having its own valence to the individual, job satisfaction could be considered as a function of the algebraic sum of the products of the valences of all other outcomes and an individual's conceptions of the instrumentality of the job for the attainment of these other outcomes (Vroom, 1964:101, 279).

Vroom's view of job satisfaction differs from most other researchers in one respect. He was very careful to point out that valence refers to anticipated satisfaction from an outcome not yet received; therefore, his model indicates that job satisfaction is the result of the anticipation of receiving outcomes from the job. Most researchers operationalize the valence model by using value, the satisfaction resulting from outcomes already received. It appears that the optimal measure is a combination of value and valence. A person's job satisfaction would definitely be a function of the rewards he has received from his job, as well as anticipated rewards he expects to receive. The best approach to take in this matter, however, remains an empirical question (Mitchell, 1974:1071;

Wanous and Lawler, 1972).

Expectancy theory has been used to explain one way of conceiving the relationship between job satisfaction and performance. Job satisfaction results from the rewards that people receive (or anticipate receiving) from their jobs. Performance level often is closely affected by attainment of rewards. Therefore, "individuals are satisfied with their jobs to the extent to which their jobs provide them with what they desire, and they perform effectively in them to the extent that effective performance leads to the attainment of what they desire" (Vroom, 1964:246).

Based on this view of the performance-satisfaction relationship, Lawler and Porter (1967) suggest that since in many cases good performance produces rewards, and rewards cause satisfaction; therefore performance causes satisfaction. This relationship constitutes a major part of their model relating managerial attitudes to managerial performance (Porter and Lawler, 1968). In two separate studies the model has been tested against a total of 783 managers from twelve organizations located throughout the United States (Lawler and Porter, 1967; Porter and Lawler, 1968). Generally the results of the empirical studies support the model.

The performance-satisfaction portion of Porter and Lawler's model is in Figure 5. The wavy line between performance and extrinsic rewards indicates that these rewards often are not tied to performance, and if they are, there is often a time lag between the performance and receipt of the reward. The semi-wavy line from performance to intrinsic rewards is to indicate that a direct connection exists between performance and intrinsic rewards if the design of the job is such that it provides the proper outcomes for the individual who has performed well to reward himself. In other words, the amount of intrinsic rewards to be received by

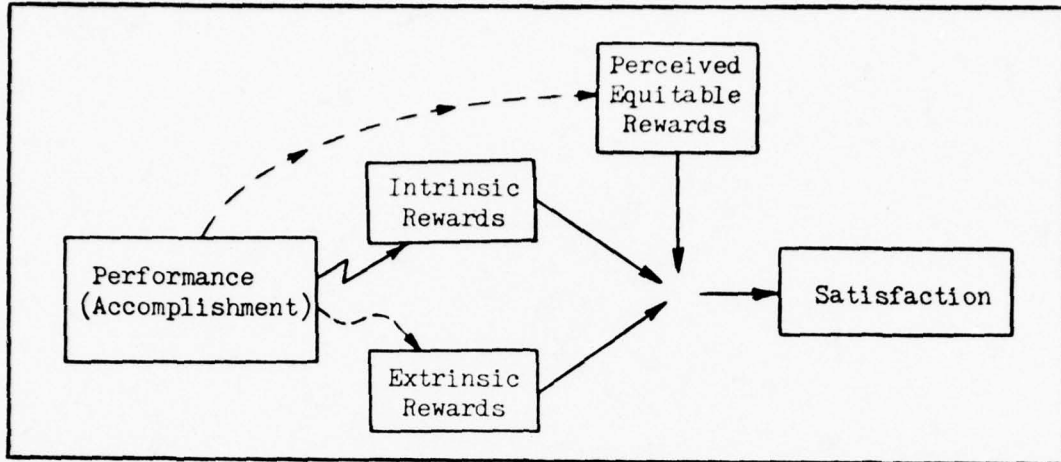

Figure 5. Model of the Relationship of Performance to Satisfaction (Lawler and Porter, 1967:23)

good performance is dependent upon the make-up of the job duties.

The dashed line between performance and perceived equitable rewards indicates that self-ratings of performance have a direct bearing on this variable. Satisfaction, then, is the result of an individual's comparison of perceived equitable rewards and perceived actual rewards. Porter and Lawler assert that if this comparison determines that actual rewards meet or exceed perceived equitable rewards, the individual will experience satisfaction. Obviously this model predicts that organizations which (1) design jobs to maximize employees' intrinsic rewards and (2) attach extrinsic rewards to performance will have employees who are highly satisfied with their jobs.

Job Characteristics Theories. The job characteristics theories propose that certain characteristics of jobs provide outcomes which fulfill employees' needs, thus leading to satisfaction. These theories are primarily job design theories which either explicitly or implicitly list job satisfaction as an outcome of designing jobs with certain characteristics.

Requisite Task Attributes. The first influential job characteristic theory was developed by Turner and Lawrence (1965). They developed a list of Requisite Task Attributes (RTA)--characteristics required by the intrinsic nature of the task--which they believed lead to better job satisfaction and attendance. The RTA characteristics are variety, autonomy, required interaction, optional interaction, knowledge and skill, and responsibility. Turner and Lawrence examined 47 blue-collar jobs in 11 industries, and computed an RTA score which reflected the level of the characteristics present in the jobs. Employees working in those jobs were surveyed to determine their job satisfaction; and employee attendance records were obtained.

Turner and Lawrence found a consistent and positive relationship between attendance and the RTA scores. This relationship held both for the overall RTA scores and the separate task attribute scores. They concluded that job design had a strong positive influence on attendance (Turner and Lawrence, 1965:48). However, the study did not find a significant relationship between RTA scores and job satisfaction for the entire sample. Turner and Lawrence discovered that the lack of association between task characteristics and satisfaction was explained by cultural setting. Employees from rural areas were much more satisfied with enriched jobs while workers from urban areas were more satisfied with unenriched jobs (Turner and Lawrence, 1965:69-90).

In spite of the RTA model's failure to address the process by which the task attributes affect behavior and satisfaction, Turner and Lawrence's work has been influential in the area of job design. One substantial contribution was their focusing on the need to consider the influence of individual and situational differences on employees' reactions

to jobs (Steers and Mowday, 1977:648).

Core Characteristics and Higher Order Need Strengths. By applying expectancy theory to Turner and Lawrence's work, Hackman and Lawler (1971) proposed explanations of the interactive processes between job characteristics and employee responses. Hackman and Lawler identified four of the Turner and Lawrence task attributes that they felt were core job characteristics leading to meaningful personal satisfaction: variety, autonomy, task identity, and feedback. They surveyed 208 employees of an eastern telephone company to determine the perceived level of the core characteristics and the employees' desires for satisfaction of higher-order needs. Hackman and Lawler were careful to point out that employees' reactions result from the perceptions of their jobs rather than objective job characteristics. Therefore, no attempt was made to objectively measure the "actual" level of core characteristics in the jobs studied.

All the workers surveyed were high in higher-order need strengths; therefore theory predicted positive relationships between job satisfaction and jobs high on the core dimensions. The results strongly supported this hypothesis. A comparison of subjects who were among the top third in higher-order need strength with those in the bottom third generally showed significant differences in the correlations of job satisfaction with the core dimensions, especially the core dimensions of variety, autonomy, and feedback.

The Hackman and Lawler study presented evidence that individual differences are important in considering the impact of various job designs. Specifically, the effect of job characteristics on employee reactions is dependent upon the employee's perceptions and the employee's needs or values (Hackman and Lawler, 1971:280).

The Job Characteristics Model. In an attempt to further extend and refine the relationships outlined above between job characteristics and individual responses to the work, Hackman and Oldham (1976) developed the Job Characteristics Model (see Figure 6). The model specifies three psychological states--experienced meaningfulness of the work, experienced responsibility for the outcomes of the work, and knowledge of the results of the work activities--which are the causal core of the model (Hackman and Oldham, 1976:255). These psychological states are stimulated by five core job dimensions: skill variety, task identity, and task significance lead to experienced meaningfulness; autonomy leads to experienced responsibility; and feedback leads to knowledge of results. The model further states that the three psychological states are moderated by individual

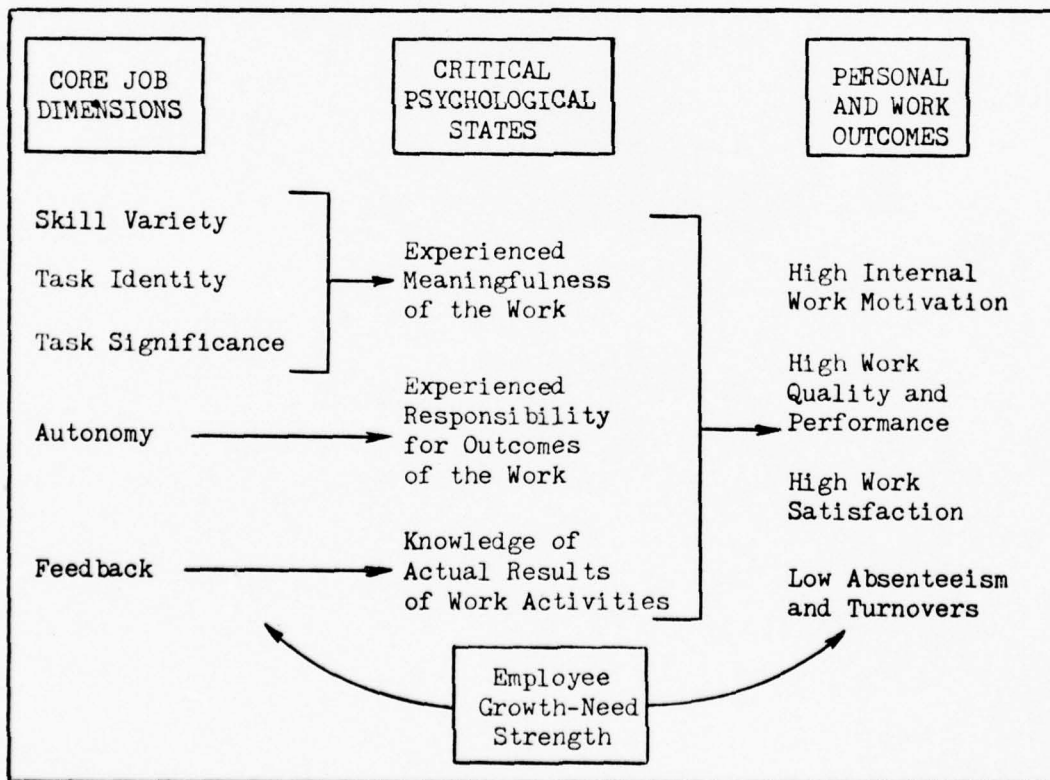

Figure 6. The Job Characteristics Model of Work Motivation (Hackman and Oldham, 1976:256)

growth need strength. The resulting outcomes predicted are high internal work motivation, high quality work performance, high satisfaction with the work, and low absenteeism and turnover.

Probably the most important aspect of Hackman and Oldham's theory is that they specify that the job design model may not apply to all employees or in every work situation (Hackman and Oldham 1976:275-277). In conjunction with the model Hackman and Oldham developed the Job Diagnostic Survey, a questionnaire designed specifically for the purpose of determining if a job and/or employee would benefit from job redesign (Hackman and Oldham, 1974; 1975).

Studies have generally been supportive of the job characteristics model, except for its predictions of employee performance. However, some have suggested that need for achievement would be preferable to growth need strength as a moderator of the task characteristic-performance relationship (Steers and Mowday, 1977:652).

Discrepancy Theory

Recently, many organizational psychologists have argued for a discrepancy approach to thinking about job satisfaction. They maintain that job satisfaction is determined by the differences between the actual outcomes a person receives from his work and some other outcome level. There are differences of opinion about what this other outcome level is, however. Some theorists say it is the outcome level the individual feels should be received, others say it is the outcome level the person expects to receive. Regardless of what is used for the baseline, all the approaches agree that what is received is compared with another outcome level. When there is a difference--when received outcomes fall short of the comparison level--dissatisfaction results (Lawler, 1973:66-67).

Discrepancy theorists also agree that people desire outcomes which satisfy their values, not their needs. This is a difficult distinction; but judging from the emphasis which they give it, it is an important distinction to these theorists. A "value is that which one acts to gain and/or to keep" (Locke, 1969:315). According to Locke, values differ from needs in that needs refer to objective requirements of an organism's survival and well-being. A value, on the other hand, is what a person consciously or subconsciously desires, wants, or seeks to attain. Thus, while needs are objective in that they exist regardless of what the individual wants, values are subjective in the sense that they are "in the consciousness" (that is, they are standards in the person's conscious or subconscious mind) (Locke, 1976:1304). Kalleberg takes this idea one step further and asserts that it is work values, "the conceptions of what is desirable that individuals hold with respect to their work activity," which are important in the study of job satisfaction (Kalleberg, 1977:129).

Katzell (1964) and Locke (1969) have probably presented the most fully developed discrepancy theory approaches to job satisfaction. Katzell asserts that dissatisfaction with an outcome is directly proportional to the absolute discrepancy between the amount of the outcome received and the desired amount, and inversely proportional to the desired amount of the outcome--a percentage discrepancy. He then defines satisfaction with an outcome as the complement of dissatisfaction.

$$S = 1 - f\left(\frac{|X - V|}{V}\right)$$

where

S = the relative satisfaction with the outcome

X = the actual amount of the outcome

V = the desired amount of the outcome
(Katzell, 1964:344).

There are two implications of Katzell's formulation which deserve to be mentioned. Like many discrepancy theorists, Katzell believes satisfaction to be a function of the difference between desired and actual outcome levels. However, he asserts that this difference should be divided by the desired amount of the outcome. This means that the more a person wants of an outcome, the less dissatisfaction will be felt with a given discrepancy. Katzell offers no explanation for this assumption, but it does have some intuitive appeal. It is analogous to saying that the more of something one wants, the less "noticeable" a given deficit will be.

A second implication of Katzell's model is that getting more than the desired amount of an outcome results in less satisfaction than getting the desired amount. Nowhere does Katzell address any difference between the reactions to too much and too little of a desired outcome. This is a definite shortcoming in the model. It is doubtful that receiving more than the desired amount of a given outcome and receiving less than the desired amount would result in the same affective response. Later developments in the theory have addressed this deficiency.

Locke (1969) proposed a discrepancy theory which differs from Katzell's in two significant features. First, Locke stresses that individuals' perceptions of outcomes received are critical to the determination of any discrepancy from the desired amount. In other words, it is the perceived discrepancy, not the actual discrepancy, which leads to dissatisfaction. Second, Locke asserts that the level of satisfaction is determined by the simple difference between what a person wants and what that person perceives as getting from the job. Locke does not include the notion of dividing the discrepancy by the desired outcome level.

It is apparent from the preceding that both Katzell and Locke believe that individuals experience satisfaction or dissatisfaction from each individual type of outcome in the work environment. These facet satisfactions are then aggregated to arrive at an overall satisfaction level. Locke states that overall satisfaction is "the sum of the evaluations of the discriminable elements of which the job is composed" (Locke, 1969:330). In a somewhat different approach, Kalleberg recommends viewing job satisfaction as a multiple regression model:

$$JS = a + \sum_{i=1}^n b_i R_i + \sum_{i=1}^n c_i V_i + e$$

where

JS = overall job satisfaction

R = level of a type of reward or outcome

V = the value of that type of reward or outcome

a, b, and c = the regression Beta coefficients

e = a statistical error term

i varies over all types of outcomes

(Kalleberg, 1977:133).

He points out that in this model all the c_i are negative because for a given level of outcomes (i.e., holding outcomes constant) the more one values those outcomes the more likely they are not fulfilled. Consequently, Kalleberg's regression equation provides a good summary model for the discrepancy approach to job satisfaction. In general it implies that, in the aggregate, the highest levels of job satisfaction will be experienced by those workers with high rewards and low values, while the lowest levels of job satisfaction will be experienced by those workers with low rewards and high values. Note that this view predicts that an

individual receiving more than the desired amount of a valued outcome will be more satisfied than if the desired amount were received.

Equity Theory

Formal conceptions of equity theory have been developed independently by Adams (1963;1965), Homans (1961), Jacques (1961), and Patchen (1961). Adams' presentation of the theory forms the basis for the discussion here for two reasons. First, Adams' development of equity theory is more explicit and extended than the others. Second, Adams' theory has received much more attention from other researchers and consequently more empirical testing.

Basic to equity theory is the concept of an exchange, or specifically social exchange. Social exchange, defined as any social situation in which exchange takes place, is inherent in the relationships between employees and employers, students and teachers, lovers, etc. Any time social exchange takes place, there is the possibility that one or more of the participants in the exchange may feel that the exchange was inequitable. Equity theory includes a model of the process through which a participant determines the equity of an exchange and the affective response to that determination. Prior to presenting the model, a few terms are defined as they pertain to this theory.

Equity theory is based on the concepts of inputs and outcomes in the exchange process. Inputs are those attributes which are brought to the exchange and which are perceived as relevant for the exchange. Some examples of inputs are education, experience, training, skill, ethnic background, social status, and appearance. It is apparent from this list of examples that anything might be an input, as long as it is perceived as relevant. Outcomes are, as defined earlier, an individual's receipts

from the exchange. Again, outcomes may be positively valued or negatively valued. Outcomes, like inputs, are as perceived by the individual.

The stress on perceptions in equity theory make it difficult in many cases to determine a priori whether a particular aspect of the exchange relationship is an input or outcome. Pritchard gives an example which illustrates this difficulty:

A great deal of responsibility on the job may be seen by one person as an outcome. He is important to the operations of the organization and his superiors trust his judgement. To another person, however, responsibility is an input in that he must "take the job home with him at night," and must bear the burden for anything that goes wrong.
(Pritchard, 1969:179)

The frame of reference in equity theory is in terms of Person and Other. Person is the individual for whom equity or inequity exists--the individual of interest. Other is any individual with whom Person makes a comparison. Other can be involved in a direct exchange relationship with Person, or both Person and Other can be in an exchange relationship with a third party.

Equity theory asserts that in any social exchange relationship Person makes a comparison between the values of his or her inputs and outcomes and the values of Other's inputs and outcomes. (It is stressed again that all these values are as perceived by Person.) Adams states that the specific comparison takes the form of a ratio of outcomes to inputs:

$$\frac{O_p}{I_p} \text{ and } \frac{O_a}{I_a}$$

where

- O is a weighted sum of all relevant outcomes
- I is a weighted sum of all relevant inputs
- p denotes Person
- a denotes Other

Equity results when

$$\frac{O_p}{I_p} = \frac{O_a}{I_a}$$

and inequity results when

$$\frac{O_p}{I_p} < \frac{O_a}{I_a} \text{ and } \frac{O_p}{I_p} > \frac{O_a}{I_a}$$

(Adams, 1965:280-1)

It is important to note that inequity results from overpayment as well as underpayment. However, equity theorists assert that the affective responses will be different for these two inequities. Underreward is said to result in feelings of unfair treatment and dissatisfaction whereas overreward will lead to feelings of guilt and discomfort. Adams further asserts that the thresholds for inequity are different (in absolute terms from a base of equity) in cases of under and overreward. The threshold would be higher presumably in cases of overreward, "for a certain amount of incongruity in these cases can be acceptably rationalized as good fortune" (Adams, 1965:282).

Empirical studies designed to investigate hypotheses developed from equity theory have generally been supportive. As a result of some studies, several extensions have been suggested to Adams' statement of the theory. Weick and Nessel (1968) propose that there are actually three kinds of inequity which are important:

1. "Own inequity" is a comparison of Person's outcome-input ratio with some internal standard derived from past social experiences. Equity is experienced when this ratio is unity (H/H or L/L).

2. "Comparison inequity" occurs when Person's ratio is not equal to Other's ratio, but Person's own ratio is unity (for example, Person's

ratio is L/L while Other's is H/L).

3. "Own-Comparison inequity" occurs when Person's own ratio is not unity and is also unequal to Other's ratio (for example, Person's ratio is L/H while Other's is H/H) (Weick and Nettet, 1968:401). Much of the more recent research has accepted these three types of equity (cf. Lane and Messe, 1972; Pritchard, 1969).

Following an extensive review of equity theory research, Pritchard (1969) made several summary statements. First, feelings of inequity (and their consequent dissatisfaction) arise first and foremost from the correspondence between Person's own outcomes and inputs--Weick and Nettet's "own equity". In other words, if Person perceives his own outcome-input ratio to be L/H, Person will be dissatisfied regardless of the ratio of anyone else in Person's environment. Lane and Messe (1972) provide empirical support for this proposition. Second, if the exchange relationship is impersonal, like that occurring in the industrial environment, Person will not experience dissatisfaction from being overrewarded with respect to Other. Pritchard proposes that Person will feel that the system is unjust, but Person will not feel responsible for it. Pritchard does not rule out the possibility of Person's feeling guilty or uncomfortable in this situation, though.

Using an extremely rigorous experimental design, Pritchard, Dunnette, and Jorgenson (1970) showed that dissatisfaction resulting from perceived pay inequities caused significant lowering of overall job satisfaction. This same experiment failed to support the theory that overreward does not lead to dissatisfaction in impersonal exchange relationships. In fact, Pritchard, Dunnette, and Jorgenson found that in 15 of 20 comparisons, the mean satisfaction of the overpaid subjects was less than that

of the equitably paid groups.

Even though equity theory has received considerable support from a number of laboratory experiments, there are problems with using equity theory to explain differences in job satisfaction. First, the theory is very general in nature. Specific statements of how one's "own equity" standard or the values of one's own inputs are derived are not available. Second, and most critical, equity theory covers a large number of variables with complex interactions. As Vroom points out, equity theory leads one to predict that job satisfaction is a function of:

1. Person's beliefs concerning the degree to which he possesses various characteristics;
2. Person's perception of the values of those characteristics as job inputs;
3. Person's beliefs concerning the degree to which he receives rewarding outcomes from his job;
4. Person's beliefs concerning the degree to which others possess various characteristics;
5. Person's beliefs concerning the extent that others receive rewarding outcomes from their jobs; and
6. The extent to which Person compares himself to Other (Vroom, 1964:171-2).

It may be that there is no simpler model which is appropriate, but the complexity of the interrelationships of these six variables make equity theory very difficult for managers to use as an operational model.

Lawler's Model of Facet Satisfaction

Lawler has integrated a number of the concepts of discrepancy theory and equity theory into a model of facet satisfaction (Lawler, 1973:74-81).

A diagram of Lawler's model is in Figure 7. It is apparent that the single most important process implied in the model is perception. Perceived job characteristics, perceived personal inputs, and perceived outcomes and inputs of referent others combine into a single perception of the amount of outcomes that should be received. On the other side of the model perceived outcomes of referent others combine with actual outcomes received to form a perception of the amount of outcomes received.

This model is a discrepancy model in that it shows satisfaction as the difference between what a person feels should be received (a) and what the person feels is actually received (b). If the individual feels that a equals b, the result is satisfaction. When a is greater than b the person will be dissatisfied. If b exceeds a the individual will experience feelings of guilt or discomfort. This comparison is made with each facet of the work situation, resulting in a number of facet satisfactions. The individual facet satisfactions then are combined by the individual to arrive at an overall job satisfaction affect.

Lawler summarizes the implications of the model by making several statements about who should be dissatisfied if the model is correct.

All other things being equal,

1. People with high perceived inputs will be more dissatisfied with a given facet than people with low perceived inputs.
2. People who perceive their job as demanding will be more dissatisfied with a given facet than people who perceive their jobs as undemanding.
3. People who perceive similar others as having a more favorable input-outcome balance will be more dissatisfied with a given facet than people who perceive their own balance as similar to or better than that of others.
4. People who receive a low outcome level will be more dissatisfied than those who receive a high outcome level.
5. The more outcomes a person perceives his comparison-other

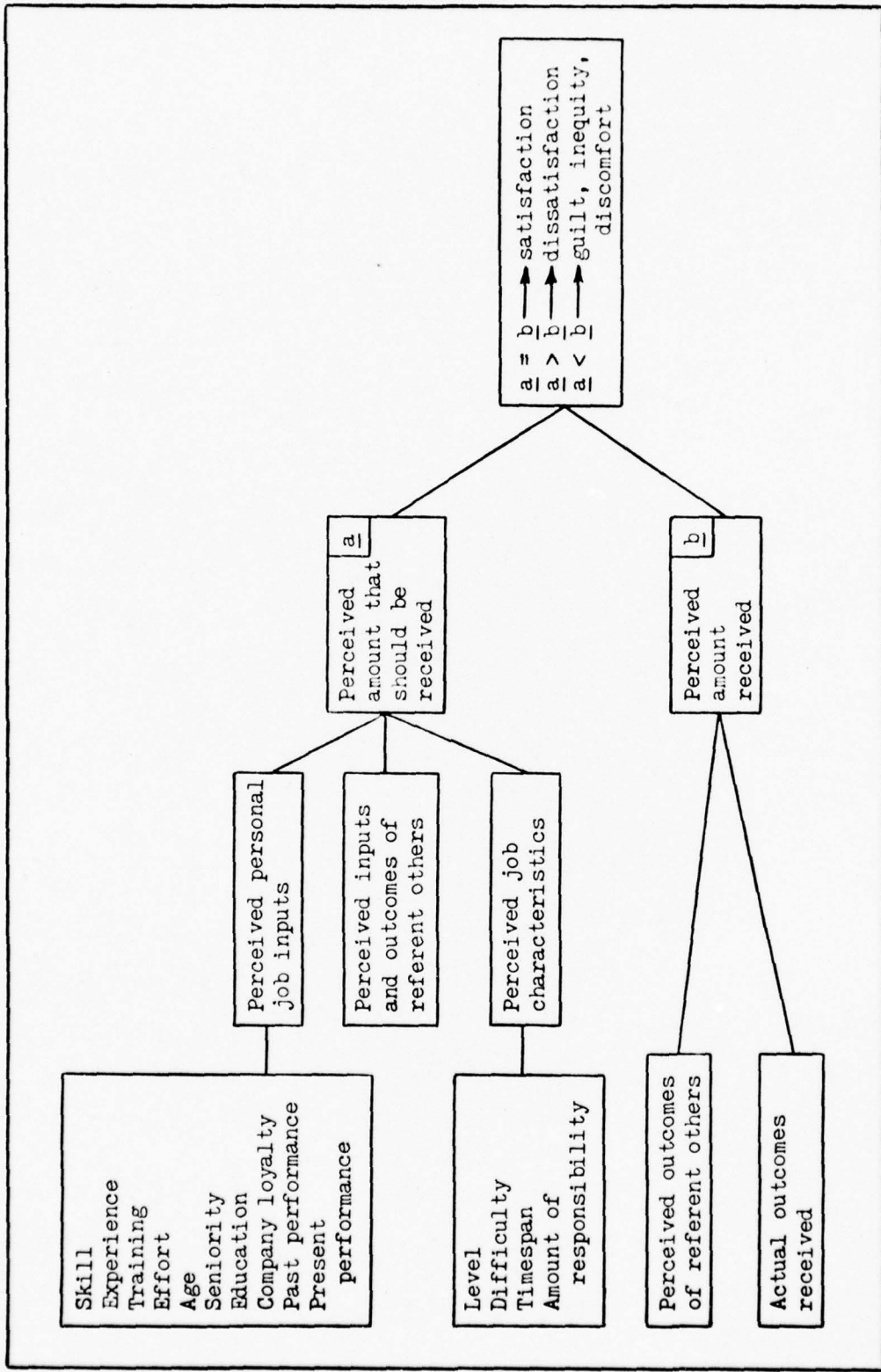

Figure 7. Lawler Model of Facet Satisfaction (Lawler, 1973:75)

receives, the more dissatisfied he will be with his own outcomes. This should be particularly true when the comparison-other is seen to hold a job that demands the same or fewer inputs (Lawler, 1973:77).

As far as this writer has been able to determine, Lawler's model of facet satisfactions has not been the subject of detailed empirical testing. Indeed, like equity theory, the model encompasses so many variables with such complex interactions that it is difficult to conceive of a way to test the entire model. However, since the theories upon which the model is based--discrepancy theory and equity theory--have received a great deal of empirical support, the model would appear to be valid. At a minimum Lawler's model provides an intuitively appealing way of conceptualizing the determinants of job satisfaction.

Clustering of Facet Satisfactions

Almost without exception, industrial psychologists agree that overall job satisfaction is some kind of aggregation of many individual facet satisfactions. One question to which there has not been general agreement, however, is how the individual facet satisfactions group or cluster to define the dimensionality of job satisfaction. Prior to attempting to answer this question, one must decide upon the level of specificity desired.

Porter, Lawler, and Hackman (1975:41-3) present an excellent argument concerning the desired level of abstraction to consider in determining the number of human needs. Their argument seems to apply equally well to the question of how many factors make up job satisfaction; therefore their line of reasoning is followed here.

Since satisfaction is an affective response to the outcomes provided by the job, the question could be restated as how many clusters of specific outcome satisfactions must be considered to determine overall job

satisfaction. Consider, for example, the physical working conditions inherent in a certain job. On a low level of abstraction, one could list satisfactions with temperature, lighting conditions, noise level, comfortable chairs, color of walls, etc. as important to the determination of job satisfaction. On a higher level of abstraction these satisfactions can be grouped together into one category of satisfaction with the physical working conditions. On a still higher level of abstraction physical working conditions can be grouped with company policies, pay, co-workers, security, and supervision to form a category called extrinsic satisfaction.

The problem, of course, is to determine the level of abstraction which results in the most parsimonious list of dimensions while still providing adequate information concerning the nature of job satisfaction. "Conceptually, the best approach would seem to group only those outcomes whose attractiveness is found to have an empirical relationship to each other." This means that a number of outcomes should be grouped together "only if when one of the outcomes is obtained the attractiveness of the others changes, and if as more of one is obtained a person's satisfaction with the whole cluster of outcomes is affected" (Porter, Lawler, and Hackman, 1975:42).

During the past 20 years, generally since Herzberg published the motivation-hygiene theory, many industrial psychologists have posited that the intrinsic-extrinsic distinction constitutes the basic dimensionality of job outcomes and facet satisfactions. Broedling (1977) and Guzzo (1979) present recent reviews of the many intrinsic-extrinsic conceptualizations in the literature. As these reviews conclude, the problem with the intrinsic-extrinsic dichotomy is precisely that there are so many different conceptualizations. In other words, to many theorists the attempt to

use this two factor approach is simply trying to jam too many concepts into too few dimensions. Researchers are beginning to question if the intrinsic-extrinsic dichotomy might not be an "over-simplification" (Broedling, 1977:274).

A number of studies and reviews have recommended a three factor solution to the question of how many groups are formed by facet satisfactions. Herzberg, Mausner, Peterson, and Capwell (1957) reviewed a number of studies that had attempted to determine the relative importance of 16 job factors simply by asking people to rate these factors in terms of importance. The result of this review, compiled from 16 studies including over 11,000 employees, show that an extrinsic reward (promotion), an intrinsic factor (interesting work), and an interpersonal factor (appreciation from supervisors) are rated as relatively high in importance (Herzberg, Mausner, Peterson, and Capwell, 1957:44). Although sometimes called by different names, these same three types of factors--extrinsic, intrinsic, and interpersonal--recur in many studies.

Friedlander (1963) factor analyzed the results of satisfaction questionnaires completed by 600 employees of a large midwestern manufacturing company. The respondents represented engineers, supervisors, and various salaried employees. Friedlander's interpretation of the results is that the underlying sources of job satisfaction group into three factors:

1. Social and Technical Environment. This factor is made up primarily of interpersonal and "other directed" sources of job satisfaction.

2. Intrinsic Self-Actualizing Work Aspects. Each item in this factor relates to the work process itself and to the development and

growth of the individual.

3. Recognition through Advancement. Most items in this factor are recognizable signs of achievement, such as promotion and merit pay increases, as a source of job satisfaction (Friedlander, 1963:248).

Using a different perspective in the data analysis, Mustafa and Sylvia (1975) arrived at similar conclusions. They gathered facet satisfaction data from 240 employees of the Public Works Commission of a medium-sized North Carolina city. Mustafa and Sylvia used Q techniques to determine how the respondents grouped in their feelings of satisfaction. Q technique or Q analysis differs from the more common R analysis in what are treated as the individual manifestation variables in the analysis. R analysis uses the questionnaire items as the measured variables. In Q analysis, the data are transposed prior to factor analysis being performed, making the individual respondents the manifestation variables. The result is that each factor is made up of groups of respondents who display similar attitudes. By analyzing these attitudes, conclusions can be drawn concerning the important factors in job satisfaction.

Mustafa and Sylvia conclude from their study that in addition to intrinsic factors which appeal to self-actualization and growth needs, there are two other types of variables important in determining job satisfaction. These are (1) social variables resulting from interactions with co-workers, and (2) working conditions and certain attendant rewards such as pay and going-home time (Mustafa and Sylvia, 1975:170).

The final study to be cited in this section involved over 2500 municipal, county, and state employees (Katz and Van Maanen, 1977). Questionnaires completed by the sample contained items measuring satisfaction with 25 facets of the work environment and items measuring 9 "objective"

characteristics of the respondents' jobs.

The primary purpose of this study was to investigate the underlying dimensionality of the factors which make up job satisfaction. To address this issue, Katz and Van Maanen subjected the questionnaire responses to a hierarchical clustering algorithm. They used a correlation matrix of the 25 satisfaction items as input measures of similarity. A multidimensional scaling routine, using the same correlation matrix as input, was used to determine the relative positions of the facets on a satisfaction map.

The results of this data analysis are shown in Figure 8. Three distinct clusters are depicted by the contour lines enclosing certain satisfaction items. The hierarchical nature of the clustering algorithm is shown by contours embedded within other contours. Katz and Van Maanen identified the three distinct nonembedded contours--referred to as loci--as job properties, the intrinsic features of the job; interaction features, the social interaction features of the work environment; and organizational policies, the policies concerning pay, promotion, training and staffing. The axes upon which the loci are plotted represent the result of the multidimensional scaling analysis. Katz and Van Maanen found that the relationships uncovered by the cluster analysis could be fully defined in two dimensional space. These two dimensions were interpreted as an intrinsic-extrinsic dimension and a long term-short term dimension.

Partial correlation and canonical correlation analyses indicated that each satisfaction locus was related to a specific job design feature and that all three loci were about equally important. The implications of these findings are important for any job design effort. Satisfactions are seen as being derived from three separate aspects of the work situation.

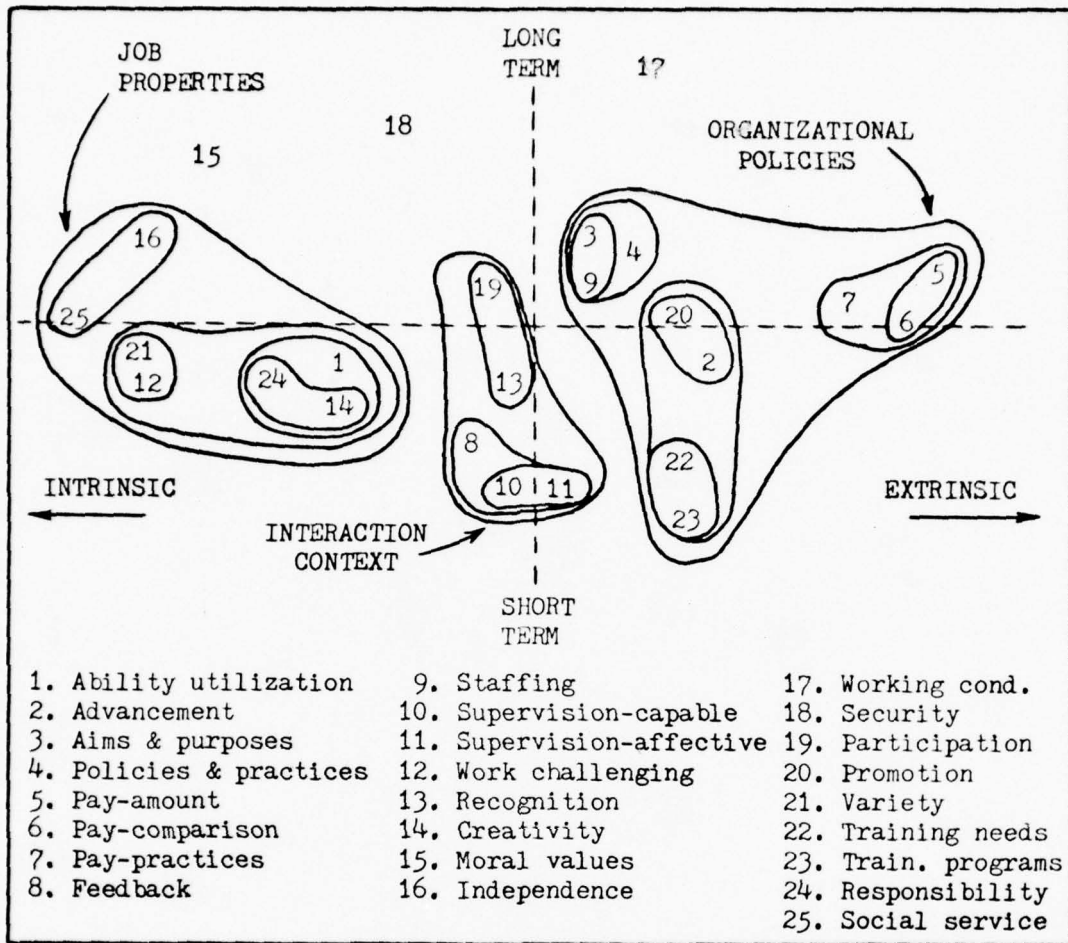

Figure 8. The Loci of Facet Satisfaction
(Katz and Van Maanen, 1977:476)

Any activity aimed at influencing job satisfaction should explicitly attend to all three of those areas.

The studies presented in this section all identify three underlying dimensions of job satisfaction. These dimensions, though not identically defined, are very similar for all three studies; and they provide a logically appealing extension to the intrinsic-extrinsic dichotomy. The intrinsic factor is left intact. It is made up of the many facets of the work itself--autonomy, task variety, challenge, responsibility, etc. The extrinsic factor is expanded into two extrinsic factors. The first is

made up of the interpersonal or social facets of the work environment. The second is composed of rewards or outcomes which are controlled by the organization--pay, promotion, working conditions, etc. In addition to its logical appeal, this conceptualization appears to better satisfy the requirements of the criteria for determining the proper level of abstraction which was presented at the beginning of this section. The facets within each cluster are empirically related since the techniques used to derive the clusters are all based on measures of similarity between the individual facets.

A second important aspect of this three-factor concept is its parallel with the historical job satisfaction theory in the United States. The opening pages of this thesis presented the major trends in job satisfaction theory as background. By way of review, three different schools of thought can be identified. First is the traditional or scientific management school which emphasizes good pay, promotions, and other extrinsic rewards provided by the organization. Second is the human relations school where social interaction is stressed as leading to satisfaction. Finally, the human resources school of thought stresses that individuals can find satisfaction in the work itself. This school emphasizes the importance of intrinsic rewards and intrinsic satisfaction (Steers and Porter, 1975:15-20). The three groups of facet satisfactions identified in this section correspond very closely with the three different approaches to job satisfaction. This correspondence (human resources with job properties, human relations with interaction features, and traditional with organizational policies) lends more weight to the propriety of a three-cluster model.

Summary

This chapter has presented only a brief overview of a few of the most widely promulgated theories and models of job satisfaction. They range from the rather simplistic need hierarchy theories to complex models of job characteristics, psychological states, and moderating need strengths.

Most theories of job satisfaction are based on some type of need fulfillment model. Job satisfaction is seen as occurring to the extent that outcomes from the work environment satisfy individual needs. The simplest need models are Maslow's hierarchy of needs and Alderder's ERG theory. Both these theories assert that individuals have a few basic needs which motivate all behavior through the tensions produced when a need is frustrated. When the need is satisfied, the tension is relieved and the individual responds with feelings of satisfaction. Satisfaction of the self-actualization or growth needs, even though not reducing the need strength, results in positive affective response also.

Achievement motivation theory stresses the importance of n Ach. Individuals high in n Ach are seen as desiring jobs high in intrinsic outcomes. The theory posits that these individuals will be very satisfied in jobs which provide responsibility, challenge, and feedback. Associated with achievement motivation theory is the idea that n Ach can be learned. This implies that organizations may benefit by training executives in n Ach.

Herzberg's motivation-hygiene theory asserts that individuals have two separate and distinct need sets, hygiene needs and motivator needs. Hygiene needs are seen as being satisfied by outcomes extrinsic to the work itself. Satisfaction of hygiene needs leads to no job dissatisfaction. Motivator needs are seen as being satisfied by outcomes intrinsic

to the work itself. Satisfaction of motivator needs is said to result in job satisfaction. Herzberg's theory also states that satisfaction of motivator needs results in high employee motivation and improved productivity.

In expectancy theory job satisfaction is likened to the valence of a particular job. Valence is defined as an individual's affective orientation toward particular outcomes. Since a job leads to many outcomes, job satisfaction is proposed to be a function of the sum of the products of the valences of all the outcomes and the individual's perceptions of the instrumentality of the job for the attainment of all the outcomes. The logical extension of this view leads to the proposition that if valued rewards (intrinsic and extrinsic) are closely tied to good performance, then good performance will lead to high satisfaction through the intervening variables, rewards.

The job characteristics theories form the basis of many job design models. The theories propose that a few core job dimensions stimulate critical psychological states. This process is seen to be moderated by growth need strength or the strength of n Ach. The results of this hypothesized psychological stimulation are high work motivation, good performance, high job satisfaction, and low absenteeism and turnover. The strength of these models lies in their emphasis on the importance of individual differences in the receptivity of employees to job design efforts, and the concomitant recommendations to assess the situation prior to redesign programs.

The second major type of job satisfaction model derives from discrepancy theory. Discrepancy theorists argue that work values, not needs, are at the core of job satisfaction. Individuals theoretically

compare the perceived level of outcomes received from their job with a desired level of outcomes (or values). Dissatisfaction results when the perceived level attained is less than the desired level. There is some disagreement among theorists as to whether outcome levels greater than desired lead to dissatisfaction, guilt, or simply higher satisfaction.

The third major type of model reviewed in this chapter is equity theory. Equity theory states that individuals form a ratio of their perceived relevant inputs to the job and perceived relevant outcomes from the job. This ratio is then compared with some internal standard and/or the person's perceptions of some referent other's input-outcome ratio. If these ratios are in balance, the individual will be satisfied with the situation. If the individual perceives his or her ratio to be less favorable than the internal standard or referent other's ratio, dissatisfaction results. Equity theory specifies feelings of guilt or discomfort (possibly even dissatisfaction) result when the individual perceives his or her ratio to be more favorable than the comparison other's.

The final section of this chapter is devoted to the question of the basic dimensionality of job satisfaction. Put another way, the question is how many different types of facet satisfactions are important in determining overall job satisfaction. A correlated question is how many different types of facet satisfactions must be considered in an attempt to improve job satisfaction through redesign of the job. Several empirical studies are presented which, along with theoretical arguments, point very strongly to a three factor concept of job satisfaction. Facet satisfactions are believed to be divided into three segments of the work environment: the job properties segment includes the intrinsic facet satisfactions, the interaction features segment contains the social and inter-

personal facet satisfactions, and the organizational policy segment is made up of facet satisfactions resulting from outcomes distributed by the organization.

The next chapter presents a model of job satisfaction based on the three cluster concept, and an empirical test of that model.

III THE EMPIRICAL STUDY

This chapter presents the details of an empirical study designed primarily to investigate the efficacy of a three cluster model of facet satisfactions. In addition to testing the model, however, a number of other hypotheses were investigated. Since many of the hypothesis tests are most easily explained in terms of the data gathered for their testing, the chapter begins with a description of the questionnaire used in the study. Following that is a description of the sample which was surveyed. The final section of this chapter presents each hypothesis individually and describes the data analysis techniques used for each hypothesis test.

The Questionnaire

The questionnaire used in this study was designed around three primary issues. The first issue, being studied by another student, was that overall job satisfaction results from outcomes associated with organizational membership and outcomes associated with job performance. Section III of the questionnaire provided data relevant to this first issue. Since details of the membership-performance research and Section III of the questionnaire are provided elsewhere, they are not included here (cf. Dixon, 1979).

The second concern basic to the questionnaire design was that job facet satisfactions group into three identifiable areas. This issue required the survey instrument to measure satisfaction with a number of different facets of the work environment. A corollary requirement established the need to measure the strength of outcomes leading to the various facet satisfactions.

Finally, validity was an important consideration. Since the researchers knew from the outset that time would not allow for rigorous validation of the survey instrument, a concerted effort was made to use established, previously validated instruments wherever possible.

The requirement to measure satisfaction with a number of different facets using a well validated instrument led to the selection of the Minnesota Satisfaction Questionnaire (MSQ) as the core of the survey instrument. The MSQ has been used extensively in research for approximately 15 years, and its validity has been supported by numerous studies (Dunham, Smith, and Blackburn, 1977; Gillet and Schwab, 1975; Weiss, Dawis, England, and Lofquist, 1967).

The remainder of this section provides the details of the questionnaire used in the empirical study. The entire questionnaire is in Appendix A.

Strengths of Outcomes. The first section of the questionnaire provided information on the degree to which certain properties exist in the respondents' work environments. The intent of Section I was to provide a measure for the strengths of outcomes associated with each facet satisfaction measured by the MSQ. In other words, ideally Section I should have measured the "objective" strength of each outcome leading to facet satisfactions measured in Section II. Unfortunately, several of the facet satisfactions were not amenable to objective measurement. For example, how does one ask for the degree to which pay exists in a work situation? Certainly there is pay associated with any formal work or job which might be of interest to this research. However, as soon as one attempts to measure "how much" pay there is, the question requires some kind of value judgement from the respondent concerning how much

pay there should be. Consequently, a question asking how much pay is available would, in actuality, be a question about satisfaction with pay. Several other facets, such as supervision, Air Force policies and practices, physical working conditions, and co-workers, similarly were not suited to objective measurement. After deleting facets which exhibited this measurement difficulty, Section I was left with 12 items: social service, creativity, moral values, independence, variety, authority, utilization of abilities, social status, advancement, recognition, feeling of achievement, and activity.

To satisfy the validity criterion, the questions in Section I were closely patterned after Section I of the Job Diagnostic Survey (JDS) (Hackman and Oldham, 1974; 1975). Where possible, questions were taken from the JDS without modification.

The general form of each question was a stem which contained the basic question as well as a brief explanatory sentence expanding on the specific issue being addressed. Responses were made on a five point Likert scale anchored at both ends and the center. An example of a Section I question follows:

5. How much variety is there in your work situation. That is, to what extent are you able to do many different things at work, using a variety of your skills and abilities?

A	B	C	D	E
Very little, I do the same routine things over and over again.		Moderate Variety		Very much, I am able to do many different things, using a number of different skills and talents.

Section I questions were scored by setting A answers equal to one, B equal to two, C equal to three, and so forth. In subsequent data analyses, the researcher assumed the data gathered by these questions

could be treated as measured on interval scales, a standard assumption for Likert scales such as used here.

Minnesota Satisfaction Questionnaire. The 1967 version of the Minnesota Satisfaction Questionnaire (MSQ) was used to measure respondents' satisfaction with 20 facets of their jobs (Weiss, Dawis, England, and Lofquist, 1967). The MSQ, a copyrighted instrument, was used with permission of Vocational Psychology Research, University of Minnesota (see Appendix B).

The MSQ consists of 100 questions, 5 for each of 20 scales. The questions are arranged in blocks of 20, with items constituting a scale appearing at 20-item intervals. Each MSQ scale provides a measure for satisfaction with a facet of the work environment. Table I contains a list of the 20 MSQ scales and an item representative of each.

Responses to each question were made on a five point Likert scale which ranged from "not satisfied" to "extremely satisfied". The specific response instructions are given below:

Ask yourself: How satisfied am I with this aspect of my job?

- (a) means I am not satisfied (this aspect of my job is much poorer than I would like it to be);
- (b) means I am only slightly satisfied (this aspect of my job is not quite what I would like it to be);
- (c) means I am satisfied (this aspect of my job is what I would like it to be);
- (d) means I am very satisfied (this aspect of my job is even better than I expected it to be);
- (e) means I am extremely satisfied (this aspect of my job is much better than I hoped it could be).

The individual MSQ items were reworded slightly to make them more applicable to the sample surveyed--Air Force officers. For example, Company Policies and Practices was changed to Air Force Policies and

Table I

MSQ Facet Scales and Representative Items

Facet Scale	Representative Item
1. Ability Utilization	The chance to do something that makes use of my abilities.
2. Achievement	The feeling of accomplishment I get from my job.
3. Activity	Being able to keep busy all the time.
4. Advancement	The chances for advancement on this job.
5. Authority	The chance to tell other people what to do.
6. Company Policies and Practices	The way company policies are put into practice.
7. Compensation	My pay and the amount of work I do.
8. Co-workers	The way my co-workers get along with each other.
9. Creativity	The chance to try my own methods of doing the job.
10. Independence	The chance to work alone on the job.
11. Moral Values	Being able to do things that don't go against my conscience.
12. Physical Working Conditions	The physical working conditions of the job.
13. Recognition	The praise I get for doing a good job.
14. Responsibility	The freedom to use my own judgment.
15. Security	The way my job provides for steady employment.
16. Social Service	The chance to do things for other people.
17. Social Status	The chance to be "somebody" in the community.
18. Supervision-Human Relations	The way my boss handles his men.
19. Supervision-Technical	The competence of my supervisor in making decisions.
20. Variety	The chance to do different things from time to time.

Practices, and references to "company" were changed to "Air Force". Further rewording was required on some items to eliminate any appearance of sexual bias. For example, "The way my boss handles his men" was reworded to, "The way my boss handles subordinates."

Scoring of the MSQ is accomplished by setting A equal to one, B equal to two, and so forth. Each scale or facet score is computed as the sum of the scores of the five items which make up that scale. This scoring method assumes interval scaled measurements, a standard assumption which has been supported by numerous validation studies (Gillet and Schwab, 1975; Weiss, Dawis, England, and Lofquist, 1967).

As a check on the scoring method just described, principal component analysis was used to evaluate the correlation structure of the five questions defining each scale. If the results of a principal component, or factor, analysis show the five items to define only one underlying factor, and the five items have similar and high loadings on that factor, summing the five responses to arrive at a single scale score is supported (Guilford, 1954). Detailed results of the principal component analysis are given in Appendix C. To summarize the results, for all scales the first factor explains from 64.5 percent to 87.4 percent of the total variance in the five items and in all cases it is the only factor with an eigenvalue greater than one. For all 20 facet scales, the eigenvalue associated with the first factor is at least four times larger than the next largest eigenvalue.

The individual item loadings on the first factor range from .566 to .956. Generally, all loadings are similar and large--only 4 of the 100 individual loadings on the respective first factor are less than .70. The results of this analysis strongly support summing the responses of

the five items defining each facet to arrive at a facet scale score.

The Manual for the Minnesota Satisfaction Questionnaire recommends checking the internal reliability for each scale (Weiss, Dawis, England, and Lofquist, 1967:14). This was accomplished by computing coefficient alpha for each scale as recommended by Nunnally (1967:210-1). Coefficient alpha is defined by:

$$r_{kk} = \frac{k}{k-1} \left(1 - \frac{\sum \sigma_i^2}{\sigma_y^2} \right)$$

where

k = number of items in the scale

$\sum \sigma_i^2$ = sum of the variances of the items

σ_y^2 = variance of the sum of the items

(Nunnally, 1967:196)

Coefficient alpha ranged from .86 to .96 for the 20 MSQ scales, indicating excellent internal reliability. The coefficient alpha calculated for each MSQ scale is included in Appendix C.

Hoppock Job Satisfaction Blank. The MSQ provides a measure for overall satisfaction which is the sum of 20 items, one from each scale. However, this researcher feared that use of the MSQ overall satisfaction score might confound some types of data analysis. For example, a multiple regression of the individual facet satisfaction scores with overall satisfaction might be misleading since the same items define both the criterion and predictor variables. Therefore, the Hoppock Job Satisfaction Blank was included to provide an independent measure for overall job satisfaction (Hoppock, 1935:243). This measure has been used extensively for over 40 years and its validity has been supported (McNichols, Stahl, and Manley, 1978).

Hoppock's job satisfaction measure consists of four general questions,

each providing seven possible responses. The Hoppock questions and the scoring of responses is given below:

- A. Which one of the following shows how much of the time you feel satisfied with your job?
1. Never.
 2. Seldom.
 3. Occasionally.
 4. About half of the time.
 5. A good deal of the time.
 6. Most of the time.
 7. All the time.
- B. Choose the one of the following statements which best tells how well you like your job.
1. I hate it.
 2. I dislike it.
 3. I don't like it.
 4. I am indifferent to it.
 5. I like it.
 6. I am enthusiastic about it.
 7. I love it.
- C. Which one of the following best tells how you feel about changing your job.
1. I would quit this job at once if I could.
 2. I would take almost any other job in which I could earn as much as I am making now.
 3. I would like to change both my job and my occupation.
 4. I would like to change my present job for another one.
 5. I am not eager to change my job, but I would do so if I could get a better job.
 6. I cannot think of any jobs for which I would exchange.
 7. I would not exchange my job for any other.
- D. Which one of the following shows how you think you compare with other people?
1. No one dislikes their job more than I dislike mine.
 2. I dislike my job much more than most people dislike theirs.
 3. I dislike my job more than most people dislike theirs.
 4. I like my job about as well as most people like theirs.
 5. I like my job better than most people like theirs.
 6. I like my job much better than most people like theirs.
 7. No one likes their job better than I like mine.

The overall job satisfaction score is computed by summing the responses to the four questions. Normally the responses for two of the four questions

are reversed in sequence when the questionnaire is administered. Due to an oversight, none of the responses were reversed in this questionnaire. This is not an uncommon oversight, however, and it is felt that it had negligible effect on the psychometric properties of the measure.

Principal component analysis of the Hoppock questions revealed that the first factor explains 77.4 percent of the variance in the four items. Further, the eigenvalue associated with the first factor is the only one greater than one, and it is seven times larger than the next largest eigenvalue. All four items have similar and high loadings on the first factor. Therefore, simple summation of the four responses to arrive at an overall job satisfaction score is strongly supported. (See Appendix C for specific results of the principal component analysis.) Coefficient alpha, computed in the same manner as for the MSQ scales, is .84. A coefficient alpha of this magnitude indicates high internal reliability for the Hoppock measure for this sample.

Demographics. The final section of the questionnaire gathered selected demographic data on the sample. Since the demographics are presented in the following section describing the sample, they will not be described here.

The Sample

This study surveyed a randomly selected portion of the Air Force officers attending two Air Force Professional Military Education courses. One course, Squadron Officer School (SOS), is designed for junior officers who have from two to eight years of total military service. The course of instruction includes management, communication, and Air Force operations; and the duration of each class is eleven weeks.

Entrance requirements for SOS are not stringent. In fact, official

Air Force policy is that all junior officers who have never failed or been deferred promotion should attend SOS in residence, and the school is designed to accommodate large numbers of students. Four classes are held each year with approximately 650 students in each class.

The second school surveyed, Air Command and Staff College (ACSC), is designed for selected officers who have from eight to fourteen years of military service. The course of instruction includes management, communication, and Air Force operations and planning. The duration of each class is ten months.

Selection for attendance at ACSC is based on a "best qualified" criteria. Each year, approximately 20 percent of the Air Force captains who are selected for promotion to major are also identified as eligible to attend intermediate service school in residence. The majority of those identified attend ACSC. Consequently, an ACSC class is representative of the top (that is, best qualified) 20 percent of all Air Force majors.

This writer was initially concerned that the use of ACSC students would significantly bias the data gathered for this study. Specifically, it was feared the select, "more successful," ACSC students would be more satisfied with their jobs than is representative of all Air Force officers of equivalent rank and length of military service. This concern was alleviated somewhat by a comparison of the mean Hoppock scores of the majors and captains surveyed in this study. A one-tailed t-test showed that their overall job satisfaction was not significantly different. This result is consistent with an Air Force wide sample taken in 1975 which showed mean Hoppock scores of captains and majors to be essentially the same (Thompson, 1975). This issue is addressed again under the heading

of limitations. One strength of this sample is worth noting, however. The respondents were from all over the Air Force and represent a wide variety of backgrounds and experience.

The names of individuals to receive questionnaires were selected at random from class rosters of the two schools. In all, 575 questionnaires were distributed. They were split between SOS and ACSC in proportion to the population represented by the students. Since SOS is made up entirely of first lieutenants and captains, and ACSC is essentially all majors, those three ranks composed the population represented. Of that population, 28 percent are majors. Therefore, 165 questionnaires (28 percent) were distributed to ACSC students and 410 were distributed to SOS students.

Respondents marked the answers to the questions on Air University Forms 4, Standard Answer Sheets. The answer sheets were electronically scanned and all responses were transferred to punch cards. The punch cards were used as initial input for the resulting data analyses.

Of the 575 questionnaires distributed, 267 were returned with usable data (46.4 percent), 83 from ACSC (50.3 percent) and 184 from SOS (44.9 percent). At first impression this may seem to be quite a low response; however, for several reasons it was about what this writer expected. First, the questionnaire was long. Under the best of circumstances, a voluntary questionnaire containing 181 items would not be expected to have a high response rate. Second, the timing of questionnaire administration was bad. The questionnaires were distributed on a Monday morning with instructions that they had to be returned by Wednesday afternoon. The SOS students, in addition to their normally very busy schedule, had a writing assignment due on Wednesday. In addition to this questionnaire, the ACSC students also received an End of Course Critique

and a Base Services Critique on Monday morning. Both these critiques were also very lengthy and had short suspenses. Consideration of these issues makes the response rate appear to be about as good as could be hoped for.

Demographics Breakdown. This subsection provides summary information on selected demographics of the sample. Complete demographic information is provided in Appendix D.

The respondents' ages ranged from 25 to 40 years. The mean age of respondents was 31 to 32 years with most respondents falling in the 27 to 28 year age group. There were 250 men in the sample and only 13 women. The vast majority of the sample, 221 (84 percent) were married; 32 (12 percent) had never been married. The education level of the sample was surprisingly high. Master's degrees were held by 126 respondents (48 percent). Another 64 (24 percent) had completed some graduate study, and 65 (25 percent) held Bachelor's degrees. The remaining 7 respondents had earned Doctor's degrees.

On the military side, the respondents were largely middle seniority captains. Seventy percent of the respondents (176) were captains, and 30 percent (79) were majors. There were only 7 first lieutenants in the sample. Thirty-seven percent of the sample (97) had from 5 to 7 years military service. Another 23 percent were in the 11 to 13 year groups and 13 percent had 8 to 10 years service. As expected, most of the respondents, 150 (57 percent), were not rated. There were 57 pilots (22 percent) and 55 navigators (21 percent) in the sample. The "average" respondent, then, was a married male in his late twenties. He was a captain with five to seven years of military service, and he was not on flying status.

Limitations of the Sample. There are several limitations associated with the sample used in this research. One limitation which immediately follows from the review of the demographics is the homogeneity of the sample. There is very little variance in the age, military experience, and especially rank of the respondents. This "sameness" of the respondents could reflect in their attitudes toward their jobs, consequently confounding the hypotheses tests.

A second limitation of this sample concerns the generalizability of the results. As mentioned earlier, the ACSC students are a select group of Air Force majors. On the other hand, the SOS students should be representative of all Air Force captains. However, the simple fact that the respondents were in student status could have clouded their attitudes toward their jobs. The questionnaire instructions directed respondents to answer the questions as they pertained to the "job held longest at (the) duty station immediately prior to attending this school." The SOS students were in the seventh week of an eleven week program, so they were not too far removed from their last jobs. Unfortunately, however, SOS is an extremely rigorous program which some students resent. This attitude, when present, would likely affect the questionnaire responses. The ACSC students were at the very end of their ten month curriculum. It is possible that the long time spent as students could have affected their job attitudes.

It is impossible to say exactly what effect, if any, these limitations have on the hypotheses tests which follow. This discussion is included here as a reminder to the reader, and the researcher, that any broad generalities based on this data should be made with caution. The remainder of this chapter presents the development of the hypotheses and the methods of testing those hypotheses.

Development of the Hypotheses

This section presents the hypotheses tested by the empirical study. Each hypothesis is stated, the theoretical basis for the hypothesis is discussed, and the data analysis methods used to test the hypothesis are briefly presented. Since several hypotheses are based on the same model, a separate subsection is devoted to the presentation of that model.

All data analyses were performed on the Control Data Corporation 6600 Cyber 7 computer system. Version 7 of the Statistical Package for the Social Sciences (SPSS) was used for all analyses except the cluster analysis. A special program written by Professor McNichols of the Air Force Institute of Technology was used for the cluster analyses.

Several of the hypotheses examined in this study have received considerable attention in previous empirical research. There are two primary reasons for including a few "standard" hypotheses here. First, it is hoped that this study will lend further support to the conclusions reached by earlier job satisfaction researchers. Second, by comparing the results of data analyses here with other data analyses treating the same issues, inferences can be made concerning the significance of the limitations discussed in the previous section.

Job Satisfaction and Age, Longevity, and Rank. Due to the nature of the sample, age, length of service, and military rank are closely related. With few exceptions, the officers in the sample entered the Air Force soon after graduating from college at age 21 or 22. Since promotion eligibility is based on length of service, and length of service varies directly with age, the relationship of these three factors is very similar for most respondents. (A detailed examination of the responses to the age, length of service, and rank questions found only 21 respondents who

did not conform to the norm. The majority of these, 11, apparently had enlisted experience prior to becoming officers. There were five respondents who apparently were promoted to major early, and two who probably were in the Medical Corps.) For purposes of developing and testing the first hypothesis, it is divided into three parts--one each for age, longevity, and rank.

H1a: Job satisfaction increases with age.

Many studies have shown that among workers in the United States, job satisfaction varies directly with age (Glenn, Taylor, and Weaver, 1977; Herzberg, Mausner, Peterson, and Capwell, 1957; Hulin and Smith, 1965; Saleh and Hyde, 1969). Several reasons have been proposed for this relationship. One plausible explanation has been termed the "cohort" theory (Glenn, Taylor, and Weaver, 1977). This theory asserts that each birth cohort of individuals entering the labor market in recent years has been slightly less inclined to receive satisfaction from their work than the preceding cohort. The major reason for this cohort difference is hypothesized to be the rising expectations of young people in America. "Along with the mass media, education and its credentials are raising expectations faster than the economic system can meet them" (Special Task Force, H.E.W., 1973:44). The education portion of this argument would not hold here since education level increases with age for this sample. Nevertheless, the many other things which lead to rising expectations--mass media, increased living standards, technological sophistication of younger people--may well apply to this sample.

An alternate explanation for the positive association of job satisfaction with age is that as workers grow older the rewards of work--income, authority, responsibility, recognition, etc.--generally tend to

increase. This explanation is consonant with need fulfillment and expectancy theories. An increase in positively valent outcomes is expected to result in an increase in the level of job satisfaction.

Partial correlation (SPSS subprogram PARTIAL CORR) is used to test this hypothesis. This correlation represents an index of the degree of linear relationship between two variables, computed while statistically controlling for the effects of one or more other variables which might confound the relationship under investigation. Hypothesis H1a predicts a positive correlation of age and job satisfaction as measured by the Hoppock Blank. Since the effects of education are expected to be counter to H1a (for this sample the older respondents have higher education levels) the hypothesis is tested while controlling for education.

The statistical significance of the sample correlation is examined by testing the following null and alternate hypotheses:

$$H_0: \rho' = 0$$

$$H_a: \rho' > 0$$

where

ρ' = the population partial correlation coefficient.

Rejection of the null hypothesis provides support for hypothesis H1a. The test statistic used is Student's t. A one-tailed test is appropriate for this and the remaining hypotheses.

H1b: Job satisfaction increases with longevity.

The positive relationship between overall job satisfaction and organizational longevity has been found by researchers almost since the beginning of job satisfaction study. The relationship can be explained by treating job satisfaction both as the cause and the effect of longevity. Many studies and literature reviews have concluded that overall job satisfaction is negatively related to turnover (Brayfield and Crockett, 1955;

Dachler and Schneider, 1978; Herzberg, Mausner, Peterson, and Capwell, 1957; Locke, 1976; Porter and Steers, 1973; Vroom, 1964). Based on the job satisfaction-turnover relationship, one can conclude that less satisfied workers tend to resign and more satisfied workers tend to remain on the job. This would result in a generally higher level of satisfaction being reported by workers whose longevity is greater. This view treats job satisfaction as the cause and longevity as the effect.

Viewed from the other perspective, people tend to receive greater rewards from the organization as their longevity increases. Most organizations have policies establishing pay raises which are based, at least in part, on seniority. Further, people tend to receive promotions the longer they stay with an organization. Both these propositions are certainly true for the sample surveyed in this study. Pay increases are established, by law, for Air Force members with every two year increase in length of service. Additionally, Air Force regulations directly tie promotion eligibility to length of service.

Partial correlation of length of service with the Hoppock measure of job satisfaction, controlling for education level, is used to test this hypothesis. The hypothesis predicts a positive correlation coefficient will result from the analysis. The test of statistical significance is identical to that for hypothesis H1a.

H1c: Job satisfaction increases with rank.

Promotion in the military means an increase in rank. Associated with promotion, of course, is an increase in both intrinsic and extrinsic rewards. Once again need fulfillment and expectancy theories predict increased job satisfaction with increased rank.

Due to the fact that the sample is almost completely captains and

majors, very little data are lost by using only the captains and majors to test this hypothesis. The reason for only using two ranks is the researcher's desire for rigor concerning the statistical analysis. Partial correlation assumes both variables in the analysis are measured using interval scales. Rank, when varying from first lieutenant through major, is only ordinal scaled. However, any variable which has only two possible values can be treated as interval scaled (Nie, et. al., 1975:4-5). Therefore, by reducing the rank variable to a dichotomy, partial correlation can be used without question.

Partial correlation of rank with Hoppock's measure of job satisfaction, controlling for education level, is used to test this hypothesis. A positive correlation coefficient is predicted by the hypothesis, and the test of statistical significance is the same as for hypothesis H1a.

Job Satisfaction and Education Level. In many discussions of job satisfaction and age, the higher education level of younger workers is given as one possible reason for their lower level of job satisfaction (Special Task Force, H.E.W., 1973:43-4; Glenn, Taylor, and Weaver, 1977). Equity theory provides a strong basis for this hypothesis. As a person's education level increases, that person is likely to perceive the education as increasing his or her level of inputs to the work situation. Consequently, the person requires an increased level of outcomes to maintain a given level of job satisfaction. All other things being equal, one would expect a lower level of job satisfaction among workers with higher education. This leads to the formal statement of the second hypothesis.

H2: Job satisfaction decreases with education level.

Partial correlation of education level (Bachelor's, Masters's or Doctor's degree) with Hoppock's job satisfaction measure is used to test

this hypothesis. Age, job longevity, and rank are the controlled variables for this analysis. A negative correlation coefficient provides support for this hypothesis. Therefore, the null and alternate hypotheses for the statistical test are

$$H_0: \rho' = 0$$

$$H_a: \rho' < 0$$

where

ρ' = the population partial correlation coefficient.

If the null hypothesis is rejected, the data provide support for hypothesis H2. As before, a one-tailed t-test is used to test the null hypothesis.

Job Satisfaction and Aeronautical Rating. The third hypothesis grew out of the researcher's ten years of experience in the Air Force. Generally, pilots receive preferential treatment from the Air Force personnel system. Within the rated force, navigators have historically felt discriminated against, usually with reason. Prior to 1974 federal law prohibited anyone other than pilots from commanding flying units. Since most navigators felt that they shared the same risks, experiences, and job knowledge as pilots in the same unit, navigators generally perceived inequity in the system. Even though the legal restrictions to command were lifted five years ago, the momentum of the system is very large. Consequently, it is still very rare for a navigator to be chosen to command an Air Force flying unit.

Between the rated and non-rated segments, rated officers are paid more than non-rated officers. This additional pay may not be significant, though, since it might be perceived as being offset by increased inputs from rated officers, for example, more personal danger in flying jobs and extensive training required of flying officers. Nonetheless, non-rated officers very likely perceive inequitable promotion opportunity. For

example, of 380 General Officers in the Air Force, 293 are pilots, 18 are navigators, and 69 are non-rated. These figures seem particularly significant when it is noted that only 17 percent of the officer corps are pilots. The hypothesis, stated formally, is

H3: Job satisfaction differs with aeronautical rating.

This hypothesis is tested by using two analyses which examine differences of sample subgroups. First, the sample is divided into two groups--rated and non-rated--and mean satisfaction scores are compared using Student's t statistic (SPSS subprogram T-TEST). Second, the sample is divided into three groups--pilots, navigators, and non-rated officers--and mean satisfaction scores are compared through a one-way analysis of variance (SPSS subprogram ONEWAY). Both analyses are predicated on two assumptions about the data. One is that the individual observations (satisfaction scores in this case) of each subgroup are normally distributed about the subgroup mean. It has been shown, however, that these procedures are very robust to this assumption and moderate departures from normality do not seriously affect the properties of the tests (Boneau, 1960; Mendenhall and Scheaffer, 1973:465). The second assumption is that the variances of the subgroup observations are equal. The procedures are robust to this assumption also; however SPSS provides information to the user concerning the validity of the equal variances assumption. Furthermore, SPSS calculates alternate statistical estimates for those occasions where subgroup variances are significantly different. The results of these analyses, reported in the next chapter, include the estimated statistics where appropriate.

The t-test is a direct test for significance of a difference in subgroup means. The null and alternate hypotheses are

$$H_0: \mu_1 = \mu_2$$

$$H_a: \mu_1 \neq \mu_2$$

where

μ_1 = population mean of satisfaction scores for rated officers

μ_2 = population mean of satisfaction scores for non-rated officers.

Rejection of the null hypothesis provides support for hypothesis H3.

Analysis of variance focuses on three types of variation in the data: variations of the individual scores about the total group mean, variations of the individual scores about each subgroup mean, and variations of the subgroup means about the total group mean. The technique uses the squared values of these variations to arrive at values for the sum-of-squared error explained by the subgroups, or between groups sum-of-squares, and the sum-of-squared error not explained by the subgroups, or within groups sum-of-squares. A test using the F statistic and a ratio of explained to unexplained sum-of-squares (as adjusted by the respective number of degrees of freedom) determines whether the difference in subgroup means is statistically significant. The null and alternate hypotheses are

$$H_0: \mu_1 = \mu_2 = \mu_3$$

$$H_a: \mu_i \neq \mu_j \text{ for any } i, j \text{ combination}$$

where

μ_1 = population mean of satisfaction scores for pilots

μ_2 = population mean of satisfaction scores for navigators

μ_3 = population mean of satisfaction scores for non-rated officers.

If these analyses indicate significant differences in subgroup means, hypothesis H3 is supported.

The Three Cluster Model of Facet Satisfaction. The preceding chapter presented reviews of several research efforts which suggest that facet satisfactions cluster into three areas of the work environment. Based on a similar literature review, Paul Daspit (1978) developed a comprehensive model of work motivation, a significant portion of which concerns the antecedents of job satisfaction. The job satisfaction portion of Daspit's model, very slightly modified, is shown in Figure 9, and forms the basis for the remaining hypotheses of this study.

The model shows the work environment leading to a number of associated outcomes. The work environment is meant to include everything associated with the work situation, such as membership in the work organization, interactions with other people, and performance of the work itself.

The outcomes received from the work environment are shown as clustering into three groups. Job properties include the outcomes emanating directly from performance of the work itself. Examples of job properties outcomes include challenge, responsibility, autonomy, and utilization of special abilities. Interaction features are those outcomes which result from interpersonal relationships. Examples are recognition, colleague assistance, and supervision. The final group, organizational policy outcomes, are the more-or-less "tangible" rewards which are administered by the work organization. This group includes pay, promotion, training, and fringe benefits. These three groups are referred to as objective work system features.

The solid line connecting the work environment with job properties outcomes signifies a direct, strong relationship. Job properties are the intrinsic outcomes derived from the work, and as such are not dependent upon any external agents for the communication or administration of

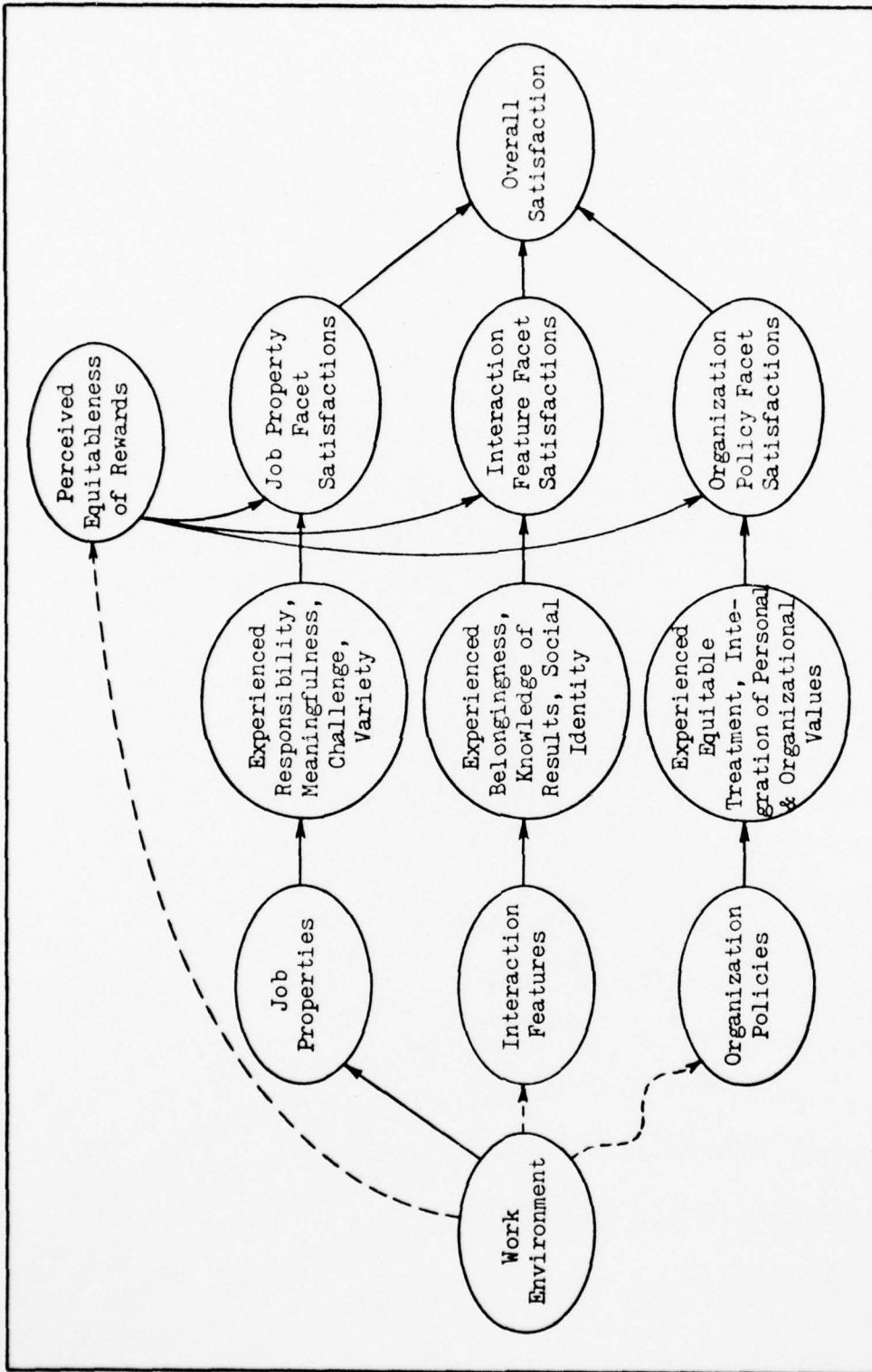

Figure 9. Job Satisfaction Portion of Dasgip's Comprehensive Model of Work Motivation (Dasgip, 1978:92)

these outcomes to the employee. On the other hand, interaction features and organizational policies are extrinsic outcomes. The broken lines from work environment to these outcome clusters represent the often indirect nature of these relationships. The wavy line from work environment to organizational policy outcomes indicates that there is often a time lag between performance of the job and the accompanying organizational rewards.

As in the Job Characteristics Model, the outcomes are shown to lead directly to several psychological states. These psychological states can be thought of as the way work environment outcomes are experienced by the employees. As such, the psychological states form the core of the model. Table II shows the proposed relationship between the outcome clusters and the psychological states. The psychological states, as stimulated by the various work environment outcomes, create affective responses by the employees. These affective responses, as moderated by perceived equitableness of the rewards, are job facet satisfactions. Finally, the facet satisfactions combine into an employee's overall job satisfaction.

Clustering of Outcomes and Facet Satisfactions. Since the next two hypotheses are based on the same theoretical development and are tested by the same analysis techniques, they are presented together. The model presented above shows the work environment outcomes and facet satisfactions forming three groups. Prior to presenting the formal hypotheses concerning those groups, the term "cluster" is defined as it is used here.

Two (or more) outcomes or facet satisfactions cluster when employees' reactions to them move similarly. For example, it is hypothesized that employees' perceptions of, and reactions to, responsibility and autonomy

Table II

Proposed Association Between Work System Features
and Psychological States (Daspit, 1978:87)

Objective Work System Features	Psychological States
Job Properties	Experienced Task Meaningfulness
	Experienced Task Responsibility
	Experienced Job/Task Challenge and Variety
Interaction Features	Experienced Belongingness
	Knowledge of Results
	Experienced Leadership Facilitation and Support
Organization Policy Variables	Social Identity
	Experienced Equitable Treatment by the Organization
	Experienced Integration of Personal and Organizational Values

in the work environment are similar. Further, if an individual is granted more responsibility, that individual will perceive autonomy, as well as responsibility, as increasing. Therefore, it is said that responsibility and autonomy cluster into the job properties type of outcomes. Conversely, it is hypothesized that responsibility and pay do not cluster together. Consequently, an increase in responsibility will not result in perceptions of increased pay, and attitudes toward the amount of responsibility in the work may be very different from attitudes toward the amount of pay.

It is apparent from the operational definition of cluster used here that employees' perceptions are at the core of the model. The reason is that outcomes perceived by the worker determine job satisfaction, not outcomes identified by some detached observer. Hackman and Lawler said it best:

It should be emphasized that, for all of the job characteristics discussed above, it is not their objective state which affects employee attitudes and behavior, but rather how they are experienced by the employees. Regardless of the amount of feedback (or variety, or autonomy, or task identity) a worker really has in his work, it is how much he perceives that he has which will affect his reactions to the job (Hackman and Lawler, 1971:264, emphasis in the original).

Section I of the questionnaire asked respondents to identify the extent to which certain outcomes were present in their work environment. What was measured, then, was not objective reality, but objective reality as perceived by the respondents. This is what the researcher wanted to measure, because it is hypothesized that the individual's perceptions lead to the clustering of work environment outcomes. The formal statement of the fourth hypothesis is

H4: Objective work environment outcomes are interpreted by employees to form three clusters: job properties, interaction features, and organization policy variables.

Basic to this hypothesis is the concept that humans perceive outcomes to cluster to satisfy their basic needs, desires, or values. Note the hypothesized three clusters of work outcomes are very closely associated with Alderfer's (1972) three types of human needs. The organization policies outcomes fulfill the existence needs; the interaction features outcomes satisfy the relatedness needs; and the job properties outcomes tend to satisfy growth needs.

A review of the twelve questions concerning objective strengths of work outcomes--Section I of the questionnaire--led to the hypothesized groups shown in Table III. Table III indicates that the questionnaire items do not provide very good coverage of the three outcome clusters. Nine of the items are expected to group as job property outcomes, two are expected to group as interaction features, and there is only one organi-

AD-A076 456

AIR FORCE INST OF TECH WRIGHT-PATTERSON AFB OH SCH00--ETC F/G 5/9
JOB SATISFACTION: LITERATURE REVIEW AND EMPIRICAL TEST OF A JOB--ETC(U)
SEP 79 T R TALBOT
AFIT/GSM/SM/79S-14

UNCLASSIFIED

NL

2 of 2

AD
A076456



END
DATE
FILMED
2-79
DDC

Table III

Predicted Grouping of Strengths of Outcomes

Objective Outcome	Job Properties	Interaction Features	Organization Policies
Ability Utilization	XXX		
Activity	XXX		
Authority	XXX	X	
Creativity	XXX		
Feeling of Achievement	XXX		
Independence	XXX		
Moral Values	XXX		
Opportunity for Advancement			XXX
Recognition		XXX	
Social Service	XXX	X	
Social Status		XXX	
Variety	XXX		

XXX Indicates primary group.
X Indicates secondary group.

zational policy variable.

Two independent statistical methods are used to test this hypothesis. The first is a principal component factor analysis (SPSS subprogram FACTOR). Factor analysis is a commonly used statistical technique aimed at identifying the underlying dimensionality of a relatively large number of variables. Stated another way, factor analysis attempts to identify the few underlying, or latent, variables which might have generated the larger number of measured, or manifestation, variables. Factor analysis also estimates the value for each of these latent variables for each case. These estimated values are called factor scores. The intent in this research is to find out if the manifestation variables measured by the questionnaire Section I can be adequately represented by three latent

variables, one for each of the hypothesized objective work system features.

Principal component analysis accomplishes this by determining the best linear combination of transformed variables--best from the standpoint of accounting for more of the variance in the data as a whole than any other linear combination of variables. The first principal component, then, may be considered to be the single best summary of linear relationships in the data. The second principal component is the linear combination of variables which accounts for the most residual variance after the effect of the first component is removed from the data. The principal component solution continues in this manner until all variance in the data is explained, usually requiring as many principal components as there are original variables. Even though some authors contend that principal component analysis is not really factor analysis, this writer uses the terms interchangeably.

The principal components are derived by first computing a correlation matrix for the data. A linear combination of factor scores is computed which provides the best approximation to the correlation matrix. The best approximation is identified by minimizing the sum-of-squared error between the estimated and actual correlations.

The solution of a principal component analysis produces an eigenvalue and associated eigenvector for each factor identified. The eigenvalue provides an indication of the fraction of variance explained by its corresponding factor. Also in the solution is a matrix of factor loadings, correlations between the manifestation variables and the factors. The magnitudes of correlations between each manifestation variable and the retained factors, the loadings, guide the interpretation of the solution. To aid with the interpretation problem, the coordinate system provided by

the retained factors is mathematically rotated to make the factor loadings more clear-cut.

The dimensionality of the factor solution can be determined by several methods. The simplest is the rule of thumb: Retain all factors which have an associated eigenvalue greater than one. A more sophisticated technique, called the "scree" test, involves plotting eigenvalue magnitude against number of factors (see Figure 10). The scree criterion specifies maintaining factors down to and including the factor which begins the scree line (McNichols, 1978a:6-24). In Figure 10, the first three factors of the seven hypothetical factors extracted would be retained. Another technique is simply to generate many different solutions, each retaining a different number of factors. Then choose the solution which has the most easily interpretable factors.

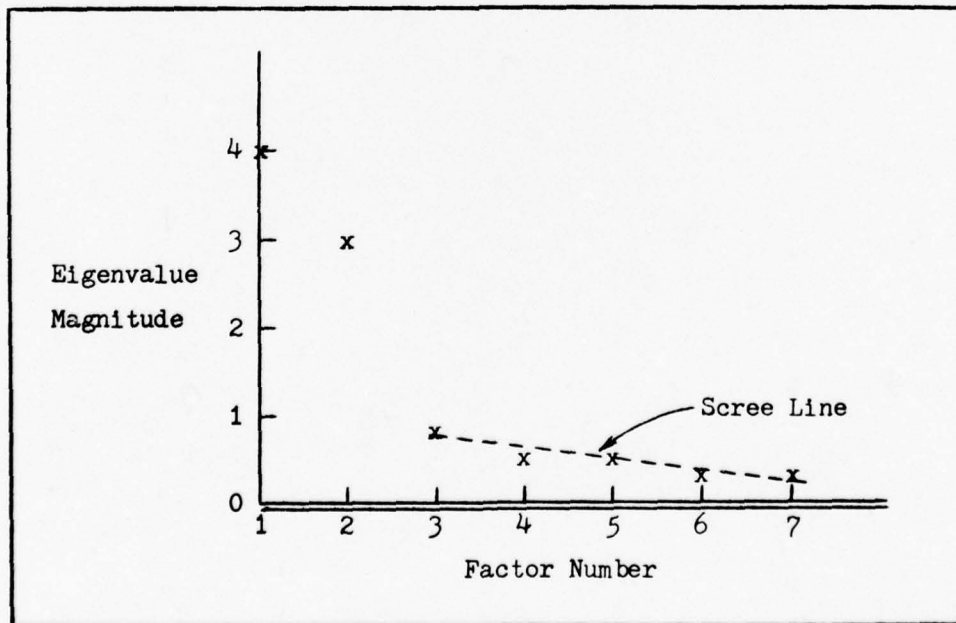

Figure 10. Scree Test for Retaining Factors: Plot of Seven Hypothetical Factors (McNichols, 1978a:6-24)

The second analysis used to test hypothesis H4 is a hierarchical clustering algorithm, ACLUS, developed by Professor Charles McNichols of the Air Force Institute of Technology (McNichols, 1978b). Using a zero-order correlation matrix as a similarity measure ACLUS iteratively combines similar variables into clusters. The procedure begins with each variable in a separate cluster. On each iteration, two clusters are combined to form a new cluster. The criterion for forming the new cluster is that the average of all the pairwise similarities between objects in the two clusters to be merged is as large as possible. The logical sequence of each iteration is shown in Figure 11. The process continues until all variables have been merged into a single cluster.

The output from ACLUS includes a summary of the clustering actions taken and a dendogram, or tree diagram, of the clustering results. By examining the dendogram, any homogeneous subsets of variables can be identified.

These two types of analysis, factor and cluster, taken together should identify any underlying structure or grouping of work environment outcomes. Ideally, both analyses would reach identical solutions with the variables grouped as hypothesized in Table III.

H5: Work environment facet satisfactions are interpreted by employees to form three clusters: job properties, interaction features, and organization policies variables.

The fifth hypothesis is a direct outgrowth of the proposition that outcomes, as experienced by the individual, lead to facet satisfactions. A review of the twenty MSQ satisfaction scales led to the hypothesized groups shown in Table IV. It is important to note that several of the scales are difficult to place entirely in one group. For example, advancement is hypothesized here to be granted by the organization;

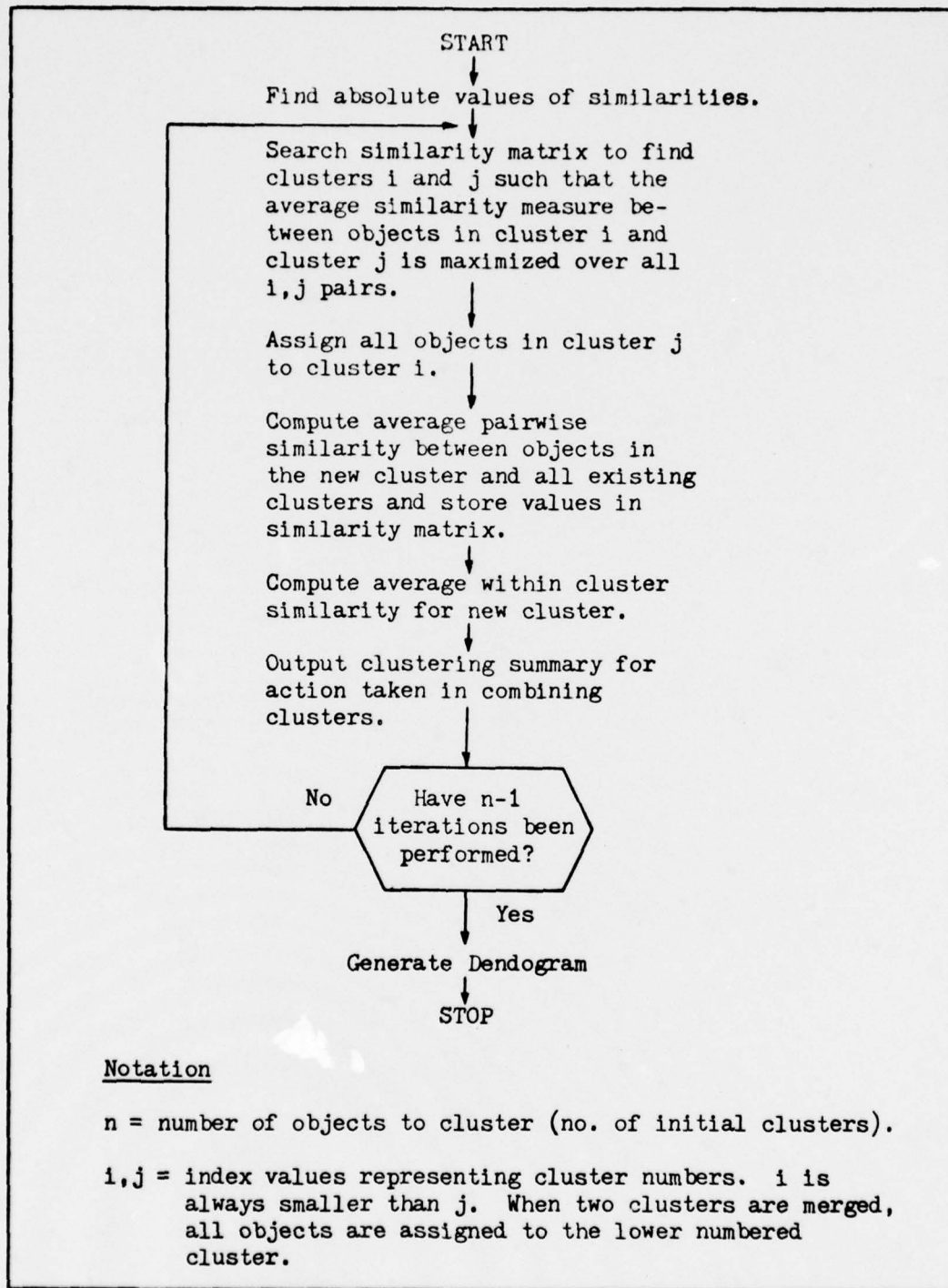

Figure 11. Logical Sequence of the ACLUS Algorithm
(McNichols, 1978b:2)

Table IV

Predicted Grouping of Facet Satisfaction

Facet Satisfaction	Job Properties	Interaction Features	Organization Policies
Ability Utilization	XXX		
Achievement	XXX		
Activity	XXX		
Advancement	X		XXX
A F Policies and Practices			XXX
Authority	XXX	X	
Compensation			XXX
Co-workers		XXX	
Creativity	XXX		
Independence	XXX		
Moral Values	XXX		X
Physical Working Conditions			XXX
Recognition	X	XXX	
Responsibility	XXX		
Security	X		XXX
Social Service	XXX	X	
Social Status		XXX	
Supervision- Human Relations		XXX	
Supervision- Technical		XXX	
Variety	XXX		

XXX Indicates primary group.

X Indicates secondary group.

consequently it would group as an organization policy variable. Another interpretation, though, might associate advancement with personal growth which would lead to intrinsic type satisfactions. This interpretation places advancement in the job properties cluster. Satisfaction with recognition presents similar difficulties. Here, recognition is hypothesized as the result of interactions with others--clients, co-workers, and supervisors. However, recognition may be interpreted as a feature of the job itself, and satisfaction with recognition might be an intrinsic satisfaction. These alternate hypotheses have some support in the literature. For example, Herzberg, Nausner, and Snyderman (1959) identify both advancement and recognition as "motivators" which lead to intrinsic satisfaction. These and other alternate interpretations are shown in Table IV as secondary associations.

This hypothesis is tested using the same analysis methods as discussed under hypothesis H4. Factor and cluster analyses are performed on the MSQ scale scores. Interpretation of the analyses is performed as in hypothesis H4.

Relative Importance of Facet Satisfaction Clusters. The final hypothesis follows from the proposed differences in the strengths of association between the work environment and the outcome clusters. Since the job properties outcomes are intrinsic outcomes not moderated by external agents, they should be more strongly experienced by the individual. Conversely, since the organization policy outcomes are externally mediated and often include time lags, they should be least strongly experienced. It is hypothesized that the more direct links result in stronger experiences and consequently stronger responses. Therefore, the job properties facet satisfactions should be stronger and thus more influential in the

determination of overall job satisfaction. Similarly, the organization policy facet satisfactions are asserted to be weakest, therefore the least influential in determining overall job satisfaction. Thus the hypothesis, stated formally, is

H6: The three clusters of facet satisfactions vary in importance to overall job satisfaction with job properties satisfactions being most important and organization policies least important.

Testing this hypothesis involves two steps and two analysis techniques. First, a principal component factor analysis is performed on the MSQ scale scores. The factor scores resulting from that analysis are then treated as predictor variables in a multiple regression analysis with the Hoppock measure of overall job satisfaction as the criterion variable.

Multiple regression is a statistical procedure which formulates a linear model of the following form:

$$y_i = \beta_0 + \beta_1 x_{i1} + \beta_2 x_{i2} + \dots + \beta_k x_{ik} + \epsilon_i$$

where

y_i = the value of the criterion variable in the i th of n cases

x_{ik} = the value of the k th predictor variable in the i th case

ϵ_i = a random error term

β_k = coefficients.

The multiple regression procedure selects Beta coefficients so as to minimize the sum-of-squared differences between the observed values of the criterion variable and the corresponding values of the criterion variable predicted using the linear model. This method of estimating the Beta coefficients is commonly referred to as the least-squares technique.

The magnitudes of the Beta coefficients in the regression model

indicate the relative predictive power, or importance, of the associated variables. This analysis provides support for the sixth hypothesis if the Beta coefficient for the factor scores associated with the job properties factor is significantly larger than the coefficient associated with the interaction feature factor, and the coefficient of the organization policy factor score is significantly smaller than the coefficient of the interaction features factor score.

This chapter has presented the empirical study. The questionnaire, the sample surveyed, and the hypotheses tested have been described in considerable detail. The next chapter contains the results of the data analyses described here.

IV Data Analysis Results

This chapter presents detailed results of the data analyses and hypotheses tests. In keeping with convention in social science research, this writer accepts as statistically significant those relationships which have a 5 percent or less probability of occurring by chance. Stated more rigorously, if a statistical test rejects the null hypothesis at the $\alpha = .05$ significance level, then the alternate hypothesis is accepted as being supported by the data. The Statistical Package for the Social Sciences (SPSS), used for these data analyses, computes the actual statistical significance for each relationship. These significance levels are reported in this chapter and the supporting appendices, denoted by the letter "S".

Data Related to the First Hypothesis

H1a: Job satisfaction increases with age.

Partial correlations of job satisfaction with age, controlling for education level, were used to test this hypothesis. The partial correlations are shown in the first column of Table V. There are statistically significant correlations of age with all MSQ facet satisfaction scores except Air Force policies and practices, compensation, and supervision-human relations. Further, the correlation of age with overall satisfaction is significant, $S = .012$. These results indicate that the tendency for older workers to be more satisfied than younger workers is both pervasive and significant. The data provide support for this hypothesis.

H1b: Job satisfaction increases with longevity.

The second column of Table V contains the partial correlations of job satisfaction with time in the Air Force, controlled for education

Table V

First-Order Partial Correlations, Controlling for Education Level

Satisfaction Factor	Age	Longevity	Rank	Overall Satisfaction
Ability Utilization	.184 S=.002	.141 S=.015	.095 S=.071	.760 S=.001
Achievement	.214 S=.001	.132 S=.021	.067 S=.149	.728 S=.001
Activity	.310 S=.001	.201 S=.001	.148 S=.011	.580 S=.001
Advancement	.132 S=.021	.064 S=.161	.031 S=.319	.591 S=.001
A F Policies and Practices	.088 S=.087	.009 S=.445	-.031 S=.423	.378 S=.001
Authority	.179 S=.003	.103 S=.057	.063 S=.166	.526 S=.001
Compensation	-.021 S=.372	-.088 S=.086	-.091 S=.080	.192 S=.001
Co-workers	.206 S=.001	.152 S=.009	.179 S=.003	.426 S=.001
Creativity	.277 S=.001	.215 S=.001	.163 S=.006	.667 S=.001
Independence	.199 S=.001	.085 S=.094	.108 S=.047	.441 S=.001
Moral Values	.143 S=.014	-.010 S=.442	.083 S=.101	.352 S=.001
Physical Working Conditions	.110 S=.045	.093 S=.076	.011 S=.432	.315 S=.001
Recognition	.227 S=.001	.139 S=.015	.100 S=.062	.611 S=.001
Responsibility	.240 S=.001	.149 S=.011	.103 S=.056	.686 S=.001
Security	.203 S=.001	.106 S=.050	.083 S=.100	.459 S=.001
Social Service	.173 S=.004	.059 S=.181	.021 S=.373	.462 S=.001
Social Status	.168 S=.005	.132 S=.021	.044 S=.251	.556 S=.001
Supervision-Human Relations	.100 S=.061	.043 S=.255	.043 S=.255	.473 S=.001

Table V (Continued)

First-Order Partial Correlations, Controlling for Education Level

Satisfaction Factor	Age	Longevity	Rank	Overall Satisfaction
Supervision- Technical	.120 S=.032	.065 S=.158	.069 S=.145	.429 S=.001
Variety	.280 S=.001	.205 S=.001	.131 S=.021	.659 S=.001
Overall Satisfaction	.146 S=.012	.114 S=.039	.065 S=.157	1.000

level. Of the MSQ facet satisfactions, half have significant positive correlations with length of service. The partial correlation of overall satisfaction with length of service is positive and significant, $S = .039$. These data provide support for this hypothesis.

H1c: Job satisfaction increases with rank.

The partial correlations in the third column of Table V represent the test of this hypothesis. Of the 20 MSQ facet satisfaction scores, only 5--activity, co-workers, creativity, independence, and variety--have statistically significant correlations with rank. Additionally, the partial correlation of overall satisfaction with rank is very small and not significant, $S = .157$. Therefore, the data do not support this hypothesis.

These analyses, taken together, support the hypothesis that workers who are older and who have been on the job longer are more satisfied. Due to the limited variance in the rank of the sample surveyed, the test of hypothesis H1c may not be very definitive. Examination of the mean Hoppock scores shows that majors' overall satisfaction score, 20.2, is higher than that of captains, 19.4. Like the partial correlation analysis, however, the difference is not statistically significant (one-tailed t-test $S = .073$).

Data Related to the Second Hypothesis

H2: Job satisfaction decreases with education level.

Partial correlations of satisfaction with education level, controlling for age, length of service, and rank, provided the test for this hypothesis. Table VI contains the results of the partial correlation analysis. As developed in the previous chapter, theory predicts the correlations will be negative. Most of the correlations with MSQ facet satisfactions are negative; however none are statistically significant.

Table VI

Third-Order Partial Correlations, Controlling for Age, Longevity, Rank

Satisfaction Factor	Correlation with Education Level	Satisfaction Factor	Correlation with Education Level
Ability Utilization	-.023 S=.365	Moral Values	.010 S=.438
Achievement	-.032 S=.310	Physical Working Conditions	-.063 S=.165
Activity	-.023 S=.360	Recognition	-.029 S=.331
Advancement	.013 S=.422	Responsibility	-.021 S=.375
A F Policies and Practices	-.002 S=.488	Security	.064 S=.162
Authority	-.047 S=.237	Social Service	-.070 S=.142
Compensation	-.096 S=.070	Social Status	.067 S=.151
Co-workers	-.090 S=.083	Supervision-Human Relations	-.055 S=.199
Creativity	-.015 S=.409	Supervision-Technical	-.042 S=.259
Independence	.018 S=.394	Variety	-.035 S=.296
Overall Satisfaction	.040 S=.272		

The correlation of education level with overall satisfaction is positive. Consequently, the data do not support the second hypothesis.

Data Related to the Third Hypothesis

H3: Job satisfaction differs with aeronautical rating.

Two analyses were used to investigate this hypothesis: t-test and analysis of variance. The results of the t-test are in Table VII. Of the 20 MSQ facet satisfactions, the subgroup scores are significantly different in all but 5. The difference in mean subgroup scores for overall satisfaction also is significant, $S = .044$. It is important to note that for all factors examined except one, in which the difference is trivial, the mean satisfaction scores are higher for the non-rated subgroup than for the rated subgroup. This result is discussed in more detail following the presentation of the analysis of variance.

The results of the analysis of variance are in Table VIII. The difference in subgroup means is statistically significant in all but 5 of the 20 MSQ facets. However, the difference in overall satisfaction scores is not significant in this analysis, $S = .158$.

The two analyses, taken together, provide strong support for the hypothesis as stated. Additionally, it is important that with very few exceptions, all of which are trivial, the mean scores of the non-rated respondents are higher than those of the rated respondents. This result is counter to the expectations of this writer, who believed rated officers would be more satisfied with their jobs in the Air Force.

Further analysis contrasting each subgroup with each other subgroup shows pilots to have the lowest job satisfaction levels. Navigators appear to be more satisfied than pilots with all areas measured except security and advancement opportunities (see Appendix E, Table E-I).

Table VII

T-tests Comparing Satisfaction Factors of Rated and Non-rated Officers

Satisfaction Factor	Rated Officers (N=106)	Non-rated Officers (N=144)	T Value	Significance (two-tailed test)
	\bar{X}	\bar{X}		
Ability Utilization	15.5	17.6	3.16	.002
Achievement	16.8	18.6	3.19	.002
Activity	16.3	18.2	3.12	.002
Advancement	13.1	14.5	2.66	.008
A F Policies and Practices	11.4	12.6	2.93	.004
Authority	15.4	17.0	3.16	.002
Compensation	11.6	12.4	1.29	.200
Co-workers	17.5	17.7	.55*	.585*
Creativity	15.2	17.7	3.98	.000
Independence	14.9	17.0	4.38	.000
Moral Values	17.2	18.8	3.23	.001
Physical Working Conditions	13.8	13.7	-.20	.841
Recognition	14.9	16.3	2.24	.026
Responsibility	15.8	18.2	4.77	.000
Security	13.4	15.4	4.10	.000
Social Service	16.1	17.7	2.81	.005
Social Status	14.0	15.3	2.56	.011
Supervision-Human Relations	15.2	15.9	1.23*	.220*
Supervision-Technical	15.3	15.7	.83*	.410*
Variety	15.4	17.4	3.39	.001
Overall Satisfaction	19.0	20.0	2.02	.044

*Subgroup variances are significantly different. These values are approximated by using separate variance estimates.

Table VIII

One-way Analysis of Variance Comparing Satisfaction Factors of
Pilots, Navigators, and Non-rated Officers

Satisfaction Factor	Pilots	Navigators	Non-rated	F-ratio	Significance
	(N=56)	(N=51)	(N=144)		
	\bar{X}	\bar{X}	\bar{X}		
Ability Utilization	15.9	15.1	17.6	5.20	.006
Achievement	16.5	17.1	18.6	5.29	.006
Activity	16.1	16.6	18.2	5.01*	.007*
Advancement	13.9	12.1	14.5	5.91	.004
A F Policies and Practices	11.4	11.5	12.6	4.22	.016
Authority	15.9	14.7	17.0	6.39	.002
Compensation	10.5	12.8	12.4	4.16	.017
Co-workers	17.6	17.2	17.7	.33*	.719*
Creativity	15.1	15.4	17.7	7.84	.001
Independence	14.8	15.2	17.0	9.76	.000
Moral Values	17.2	17.2	18.8	5.36	.005
Physical Working Conditions	13.4	14.4	13.7	.73	.484
Recognition	14.8	15.0	16.3	2.44	.089
Responsibility	15.9	15.5	18.2	11.72	.000
Security	14.3	12.5	15.4	10.79	.000
Social Service	16.1	16.0	17.7	4.06	.018
Social Status	14.3	13.7	15.3	3.71	.026
Supervision- Human Relations	15.6	14.9	16.0	.97*	.382*
Supervision- Technical	15.4	15.2	15.7	.30*	.741*
Variety	15.6	15.2	17.4	5.78	.004
Overall Satisfaction	19.3	18.9	20.1	1.86	.158

*Subgroup variances are significantly different. These values should be treated as approximations only.

Additionally, the mean satisfaction scores of non-rated officers are higher than those of pilots in every area surveyed, and eleven of those differences are statistically significant using a two-tailed t-test (see Table E-II). An analysis of these results and the possible reasons for them are in Chapter V.

Data Related to the Fourth Hypothesis

H4: Objective work environment outcomes are interpreted by employees to form three clusters: job properties, interaction features, and organization policy variables.

Two techniques, principal component factor analysis and hierarchical clustering analysis, were used to examine this hypothesis. The first issue addressed by factor analysis is the underlying dimensionality of the manifestation variables. The eigenvalue structure which resulted from the principal component analysis contains only two factors with associated eigenvalues greater than one. A scree test, shown in Figure 12, also indicates that two factors should be retained. In an attempt to

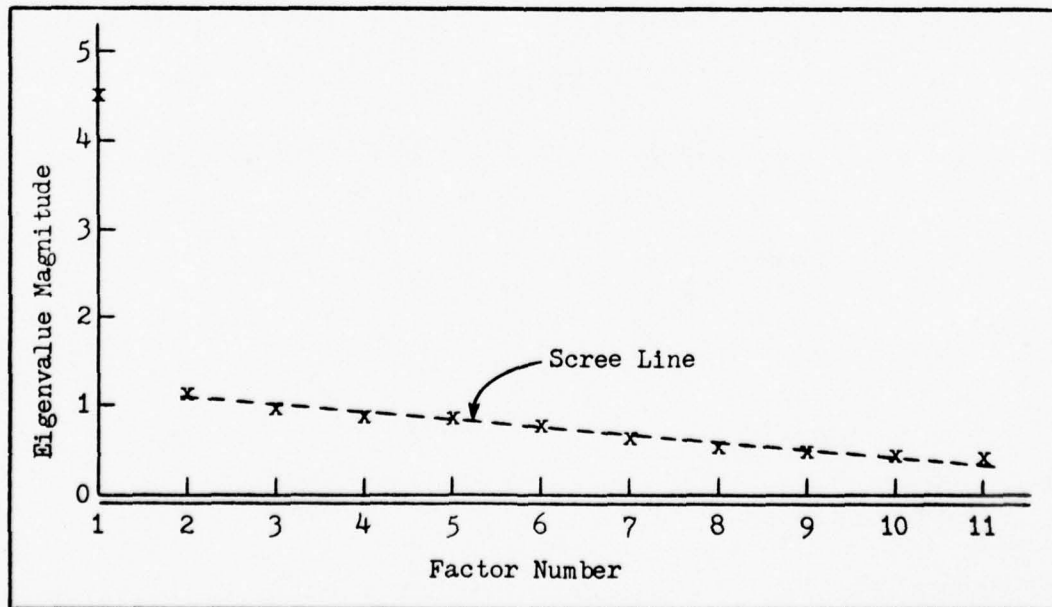

Figure 12. Scree Test for Dimensionality of Objective Outcome Strengths

reduce the number of complex variables (variables loading highly on both factors) solutions rotated by VARIMAX, QUARTIMAX, EQUIMAX, and OBLIQUE techniques were examined. The QUARTIMAX procedure, which operates to simplify the rows in the factor structure, provided the solution with the fewest complex variables.

Table III, which contains the predicted grouping of strengths of outcomes, is repeated here for the convenience of the reader. Table IX contains the factor structure matrix for the two factor solution. The table entries under the "Factor 1" and "Factor 2" headings are factor loadings, the correlations of the manifestation variables with the respective factor. The communality, presented in the last column, is the percent of variance in the manifestation variable which is explained by all the factors in

Table III
Predicted Grouping of Strengths of Outcomes

Objective Outcome	Job Properties	Interaction Features	Organization Policies
Ability Utilization	XXX		
Activity	XXX		
Authority	XXX	X	
Creativity	XXX		
Feeling of Achievement	XXX		
Independence	XXX		
Moral Values	XXX		
Opportunity for Advancement			XXX
Recognition		XXX	
Social Service	XXX	X	
Social Status		XXX	
Variety	XXX		

XXX Indicates primary group.
X Indicates secondary group.

Table IX

QUARTIMAX Rotated Factor Structure Matrix for Objective Outcome Strengths

Objective Outcome	Factor 1	Factor 2	Communality
Ability Utilization	.734		.604
Activity	.598		.358
Authority	.642		.412
Creativity	.719		.518
Feeling of Achievement	.627	.514	.657
Independence	.498		.258
Moral Values		.735	.541
Opportunity for Advancement	.563	.418	.491
Recognition		.564	.448
Social Service	.555		.318
Social Status	.573	.414	.500
Variety	.750		.564
Eigenvalue Magnitude	4.50	1.17	
Cumulative Percent of Variance Explained	37.5	47.3	

Note: Factor loadings less than 0.4 are not included.

the solution.

The first factor appears to be an intrinsic, job properties, factor. Of nine outcomes which were predicted to group into job properties, eight load highly on factor one. Moral values, contrary to the hypothesis, does not load on this job properties factor. Social status, which was predicted to be purely an interaction feature outcome, has a primary loading on this first factor. Opportunity for advancement, the only organization policy outcome measured, has significant loadings on both factors. Overall, the first factor supports the hypothesized job properties cluster of work outcomes.

The second factor is composed of the hypothesized interaction features

outcomes and some of the job properties outcomes. Recognition, as predicted, loads primarily on this factor. In addition to the primary loading on the first factor, social status has a significant secondary loading on this factor. Contrary to the hypothesis, moral values loads only on this factor, and feeling of achievement has a secondary loading on this factor. Therefore the second factor is primarily a moral values and recognition factor, and consequently is not supportive of the hypothesis.

Results of the cluster analysis are shown in Figure 13. (A clustering summary which includes the similarity measures is in Appendix E, Table E-IV.) The first iteration combined ability utilization and feeling of achievement, which are two job properties outcomes. The second iteration combined two more job properties outcomes: variety and social service.

The third iteration constituted a departure from the hypothesis. Social status, a hypothesized interaction features outcome, was merged with opportunities for advancement, the only organizational policy outcome measured by the questionnaire. The high average similarity between these two outcomes, .506, is understandable in light of the sample surveyed. Advancement means increases in rank; and social status, in the Air Force, is very closely associated with rank.

The fourth iteration was also contrary to the hypothesis. The cluster containing social status and opportunity for advancement was merged with the cluster containing ability utilization and feeling of achievement. This combined interaction features with job properties while many job properties outcomes had not yet been clustered with each other.

The fifth iteration merged activity into the cluster containing creativity and variety. This appears to be a job properties cluster.

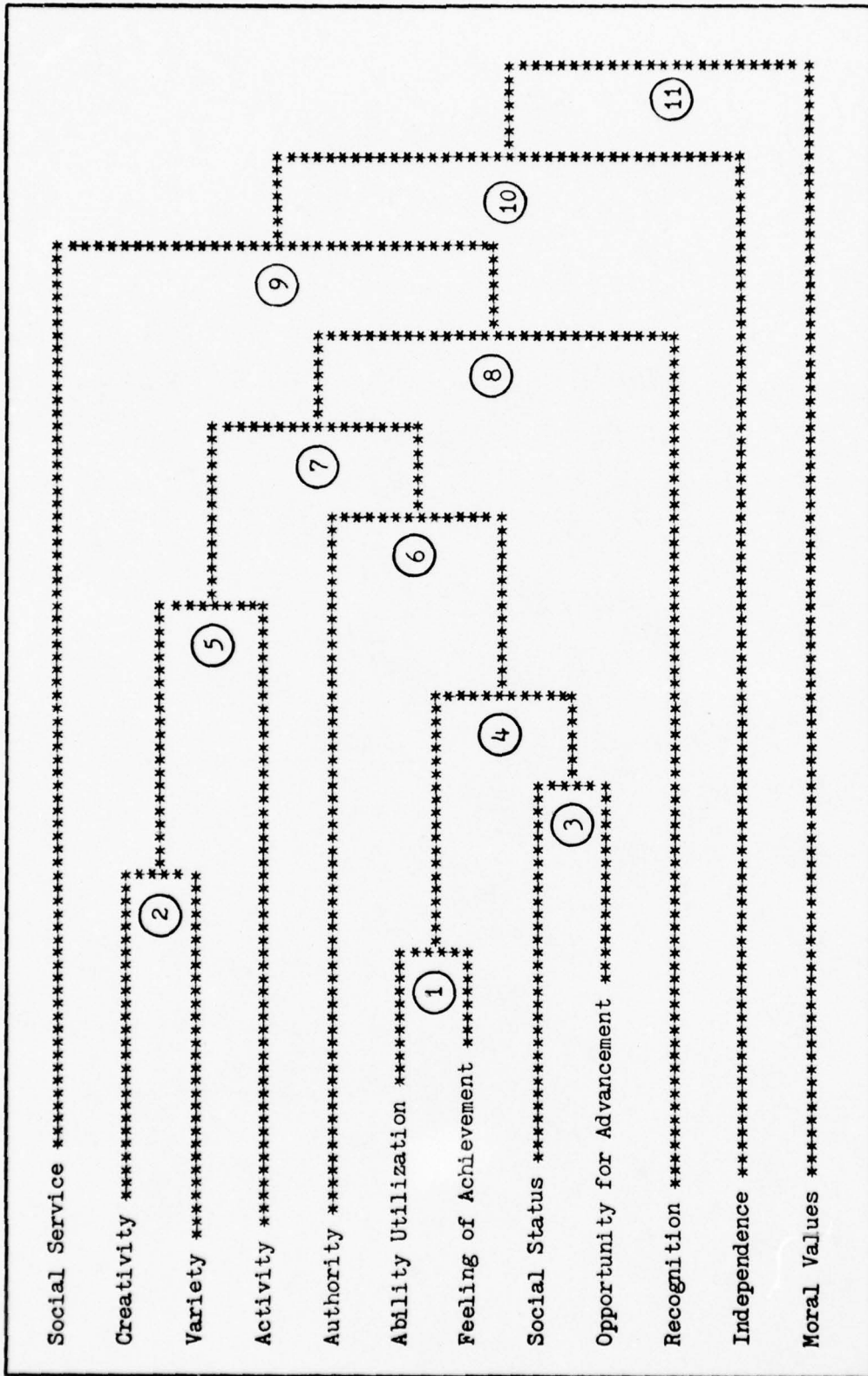

Figure 13. ACLUS Dendrogram Showing the Clustering of Objective Outcome Strengths
 (Numbers refer to the iteration on which the depicted action took place.)

The sixth iteration merged authority into the cluster containing ability utilization, feeling of achievement, social status, and opportunity for advancement. Theory predicted that authority would cluster primarily with the job properties and secondarily with the interaction or social outcomes. This action does group authority with both social and intrinsic outcomes.

The seventh iteration combined the two previously formed clusters into one large group. The remaining iterations simply forced the remaining outcomes, recognition, social service, independence, and moral values, into the one cluster. The last five actions are contrary to the hypothesis, which would have all outcomes (except advancement opportunities) form into two separate clusters before the clusters merged.

In the final analysis, the clustering algorithm identified two clusters of outcomes. The first consists of outcomes relating to creativity, variety, and activity, clearly an intrinsic cluster. The second cluster consists of outcomes relating to authority, ability utilization, feeling of achievement, social status, and opportunity for advancement. These outcomes are mixed, intrinsic and extrinsic. This cluster does not support the hypothesis.

Taken together the factor and cluster analyses provide, at best, only weak support for the fourth hypothesis. The analyses support the hypothesized intrinsic work system feature. Beyond that, however, the analyses results are inconsistent with the hypothesized relations. This result does not come unexpected, though, since the questionnaire section which measured objective work outcomes did not measure an adequate cross section of outcome types. Even though these data fail to support H4, one cannot conclude that they refute it.

Data Related to the Fifth Hypothesis

H5: Work environment facet satisfactions are interpreted by employees to form three clusters: job properties, interaction features, and organization policies variables.

Like H4, this hypothesis was tested using both factor analysis and cluster analysis. The factor analysis is discussed first.

The eigenvalue structure resulting from the principal component analysis identifies three factors with associated eigenvalues greater than one. A scree test, shown in Figure 14, further supports a three factor solution as presenting the proper dimensionality of the MSQ facet satisfaction scores.

Table IV, Predicted Grouping of Facet Satisfactions, is repeated here for the convenience of the reader. The factor structure matrix for the three factor solution to the principal component analysis is in Table X.

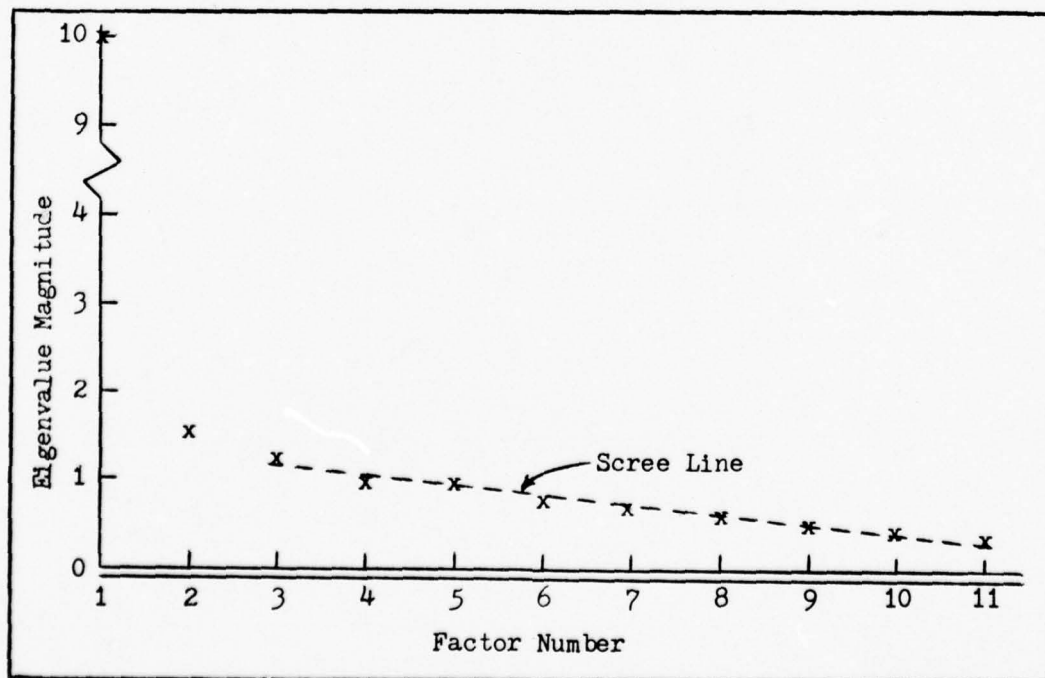

Figure 14. Scree Test for Dimensionality of MSQ Facet Satisfactions

Table IV

Predicted Grouping of Facet Satisfaction

Facet Satisfaction	Job Properties	Interaction Features	Organization Policies
Ability Utilization	XXX		
Achievement	XXX		
Activity	XXX		
Advancement	X		XXX
A F Policies and Practices			XXX
Authority	XXX	X	
Compensation			XXX
Co-workers		XXX	
Creativity	XXX		
Independence	XXX		
Moral Values	XXX		X
Physical Working Conditions			XXX
Recognition	X	XXX	
Responsibility	XXX		
Security	X		XXX
Social Service	XXX	X	
Social Status		XXX	
Supervision-Human Relations		XXX	
Supervision-Technical		XXX	
Variety	XXX		

XXX Indicates primary group.

X Indicates secondary group.

Table X

VARIMAX Rotated Factor Structure Matrix for MSQ Facet Satisfaction

Facet Satisfaction	Factor 1	Factor 2	Factor 3	Communality
Ability Utilization	.794			.742
Achievement	.836			.828
Activity	.824			.706
Advancement	.612			.596
A F Policies and Practices			.747	.664
Authority	.655			.553
Compensation			.782	.630
Co-workers	.407	.540		.461
Creativity	.868			.820
Independence	.644			.475
Moral Values	.522			.345
Physical Working Conditions		.371		.243
Recognition	.563	.537		.676
Responsibility	.855			.848
Security	.547		.447	.533
Social Service	.662			.536
Social Status	.644			.583
Supervision- Human Relations		.907		.879
Supervision- Technical		.919		.880
Variety	.864			.799
Eigenvalue Magnitude	10.04	1.55	1.20	
Cumulative Percent of Variance Explained	50.2	58.0	64.0	

Note: Except for Physical Working Conditions, factor loadings less than 0.4 are not included.

(VARIMAX rotation, which provided the fewest complex variables, was used in this analysis.) The first factor is clearly an intrinsic job properties factor. All ten facets hypothesized to group primarily as job properties have high loadings on the first factor. There are a few items on the first factor which are contrary to the hypothesis, however. Satisfaction with advancement was hypothesized to be primarily an organization policy variable. The high loading of advancement on factor one indicates that the respondents' satisfaction with advancement opportunities is closely related with their satisfaction resulting from properties of the work itself. Satisfaction with co-workers, recognition, and social status were expected to group as interaction features. Co-workers and recognition do have high loadings on the second factor, but their loadings on the first factor indicate the respondents perceive them as intrinsic as well as interactional facets. The singular high loading of satisfaction with social status on the first factor indicates the respondents see this facet as internally generated. In retrospect, this is reasonable since social status may not be granted by others as much as it is defined internally.

The second factor appears to be the hypothesized interaction features satisfactions. Four of the five facets which were predicted to group as interaction features load highly on this factor. The only predicted high loading which did not appear was satisfaction with social status, which is discussed above. Contrary to the hypothesis, however, satisfaction with the physical working conditions loads most highly on this factor. Further investigation leads one to believe this is merely a quirk of the three factor solution. The magnitude of this loading is only .37; in fact, all three factors taken together account for only 24 percent of the

variance in the physical working conditions scores. Furthermore, in a four factor solution, this facet loaded most highly (.56) on a factor with compensation (.79 loading) and Air Force policies and practices (.50 loading).

The third factor appears to be the hypothesized organization policies factor. Three of the five predicted organizational policies facets--Air Force policies and practices, compensation, and security--load highly on this factor. Satisfaction with advancement and physical working conditions, predicted to group on this factor, load most highly elsewhere. Both of these variables are discussed above.

Overall, the factor analysis provides rather strong support for the hypothesis. Of the 20 primary associations, 16 are as predicted. With the possible exception of satisfaction with advancement, the loadings which are counter to the predictions are understandable in light of the sample and the Air Force environment. On the other hand, the loadings of advancement and recognition on the job properties factor is consistent with other research which places them in the intrinsic category.

Results of the clustering algorithm are shown in Figure 15. (A clustering summary which includes the average similarity measures is in Appendix E, Table E-V.) The first iteration combined supervision-human relations with supervision-technical competence. The second through sixth iterations combined the job properties facets of creativity, responsibility, ability utilization, achievement, variety, and activity. The seventh iteration represented the first departure from the hypothesis when social status was combined with advancement opportunities. This same association took place with the objective outcome strengths and the factor analysis. Obviously the respondents perceive advancement to be very closely asso-

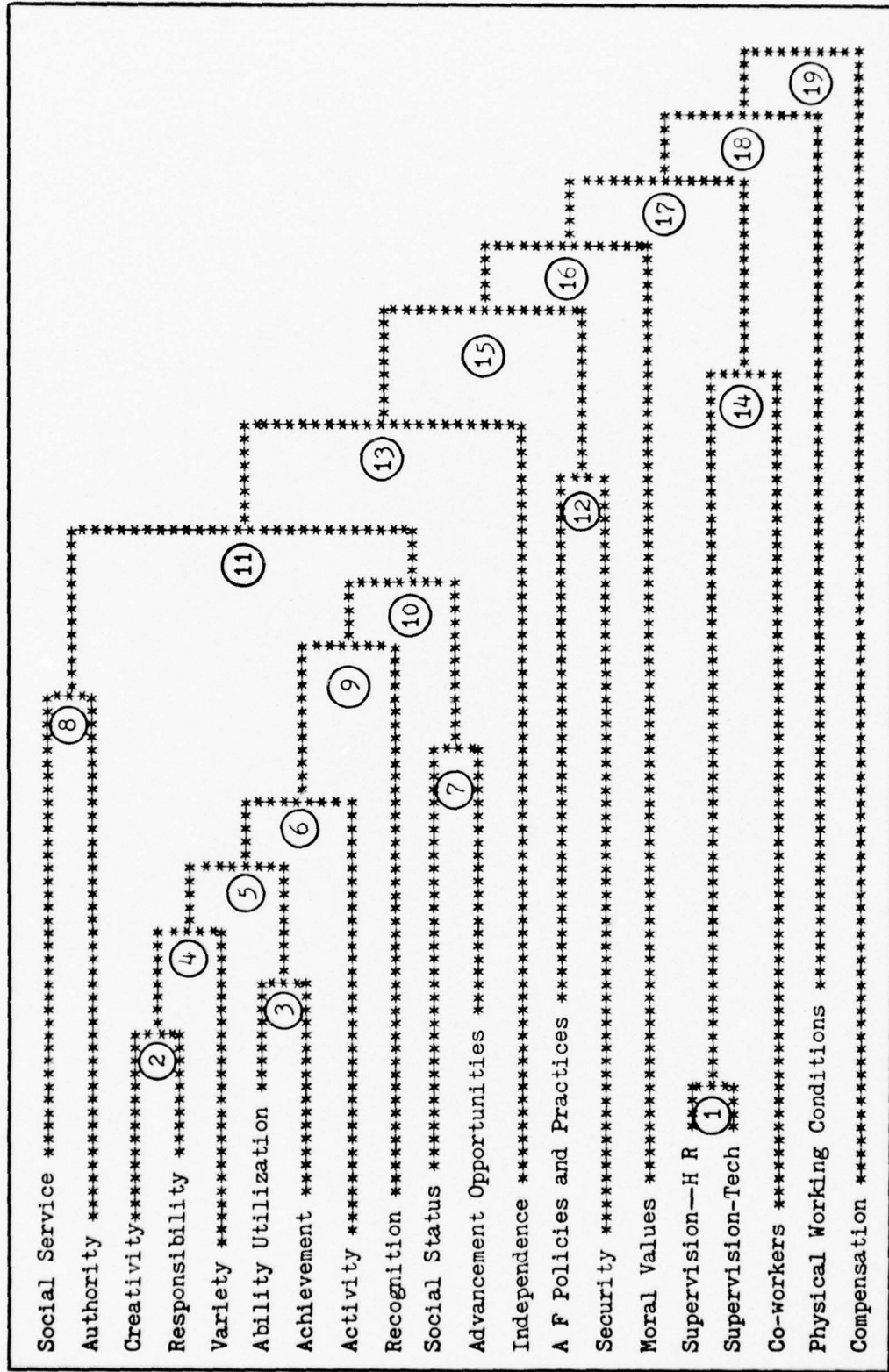

Figure 15. ACLUS Dendrogram Showing Clustering of MSQ Facet Satisfaction (Numbers refer to the iteration on which the depicted action took place.)

ciated with social status. The eighth iteration combined two job properties facets--social service and authority. The ninth and tenth iterations constituted further departures from the hypothesis. On these iterations recognition, a hypothesized interaction features facet, and the social status-advancement cluster were combined with the job properties facets previously merged. The eleventh and thirteenth iterations added social service, authority, and independence to the job properties cluster.

The twelfth iteration formed what might be called the organization policies cluster, such as it is. Air Force policies and practices were merged with security in this iteration. The fourteenth iteration completed the interaction features cluster by merging co-workers with the supervision facets. The remaining iterations simply forced the clusters to merge into a single group. It is important to note that the last two facets to be merged were physical working conditions and compensation. Theory would have them combining with Air Force policies and practices and security much earlier to form the organization policies cluster.

In the final analysis, the clustering algorithm identified three homogeneous groups: a large job properties cluster containing all the items from independence upward in Figure 15; an interaction features cluster containing supervision and co-workers; and a small organization policies cluster composed of Air Force policies and practices and security. Taken together, the factor and cluster analyses support the fifth hypothesis.

Data Related to the Sixth Hypothesis

H₆: The three clusters of facet satisfactions vary in importance to overall job satisfaction with job properties satisfactions being most important and organization policies least important.

This hypothesis test consisted of first performing a principal com-

ponent factor analysis on the MSQ facet satisfaction scores. This analysis identified the three factors in Table X. The factor scores for each case, computed during the principal component analysis, were used as predictor variables in a multiple regression with the Hoppock measure of overall satisfaction as the criterion variable. Note that the factor scores computed by SPSS are all standardized; that is, they all have means of zero and standard deviations of one.

The multiple regression results are in Table XI. The coefficient of determination, R^2 , for this model is .581. This indicates that the model explains 58 percent of the variation in the Hoppock scores. This is considered a good result when explaining the variance of one job satisfaction measure with a different measure, especially since the regression model is two steps removed from the raw data.

Table XI

Multiple Regression of Factor Scores with Overall Satisfaction

Predictor Variable	Beta Coefficient	Coefficient Significance
Job Properties Factor Scores	2.67	.000
Interaction Features Factor Scores	1.39	.000
Organization Policies Factor Scores	.78	.000
Constant	19.62	0
Multiple Correlation Coefficient	R = .763	
Coefficient of Determination	$R^2 = .581$	

Since the factor scores are all standardized to the same scale, relative importance of the predictor variables is represented by the relative magnitudes of the Beta coefficients. Since the Beta coefficient associated

with the job properties factor is almost twice as large as the next largest coefficient, one can conclude that the job properties factor has more predictive power, or is more important, in determining overall satisfaction than the other factors. Similarly, the Beta coefficient for the interaction features factor is almost twice as large as the coefficient associated with the organization policies factor. This indicates that interaction features variables are more important in determining overall satisfaction than organization policies variables.

A more rigorous comparison, complete with tests of statistical significance, can be accomplished by alternately forcing two of the coefficients to be equal and investigating the increase in error sum-of-squares. The null and alternate hypotheses are:

$$H_o: \beta_1 = \beta_2$$

$$H_o: \beta_2 = \beta_3$$

and

$$H_a: \beta_1 \neq \beta_2$$

$$H_a: \beta_2 \neq \beta_3$$

where

β_1 = Beta coefficient of job properties factor scores

β_2 = Beta coefficient of interaction features factor scores

β_3 = Beta coefficient of organization policies factor scores.

The test statistic is

$$F_o = \frac{(SSE^* - SSE)/1}{SSE/(n-k-1)} \sim F_{1,n-k-1}$$

where

SSE* = error sum-of-squares for constrained model

SSE = error sum-of-squares for full model

n = number of observations = 250

k = number of predictor variables in the full model = 3.

The results of these tests are in Table XII. Both tests reject the

Table XII

Tests of Differences in Magnitudes of Beta Coefficients

Model Constraints	SSE	F-ratio	Significance
$\beta_1 = \beta_2$	1941.19	29.44	< .01
$\beta_2 = \beta_3$	1780.52	6.64	< .01
Full model SSE = 1733.72; $F_{.01,1,246} = 6.63$			

null hypothesis and conclude that the Beta coefficients are not equal.

One more item should be addressed before this hypothesis test can be complete. The preceding analysis may be confounded due to the fact that the job properties factor had many more variables with high loadings than the other two factors. As another check of the relative importance of the facets, the zero-order correlations of facet satisfaction scores with overall satisfaction scores were examined. Table XIII contains these correlations. The bottom row of Table XIII shows that the mean correlation of the hypothesized job properties facets with overall satisfaction was largest, and the mean correlation of the hypothesized organization policies facets with overall satisfaction was smallest. This provides another indication of the relative importance of the facet types. All analyses support the sixth hypothesis.

The next chapter summarizes the specific results that are presented in this chapter and discusses the findings of this study. Some conclusions and their implications are also presented.

Table XIII

Zero-Order Correlations of MSQ Facet Satisfaction Scores
with Hoppock Scores

Job Properties Facets	Corr	Interaction Features Facets	Corr	Organizational Policies Facets	Corr
Ability Utilization	.758	Co-workers	.434	Advancement	.580
Achievement	.734	Recognition	.607	A F Policies and Practices	.398
Activity	.571	Social Status	.561	Compensation	.208
Authority	.536	Supervision- Human Relations	.470	Physical Working Conditions	.322
Creativity	.678	Supervision- Technical	.438	Security	.476
Independence	.449				
Moral Values	.368				
Responsibility	.675				
Social Service	.471				
Variety	.655				
Mean Correlation	.590	Mean Correlation	.502	Mean Correlation	.397

Note: All correlations are statistically significant at $S = .001$.

V Summary and Conclusions

The primary objective of this research was to test the efficacy of a three cluster model of facet satisfactions. A questionnaire, using the Minnesota Satisfaction Questionnaire (MSQ) as its core, was distributed to 575 Air Force officers attending Squadron Officer School and Air Command and Staff College. Usable responses to the questionnaire were returned by 267 individuals.

The data gathered by the questionnaire were subjected to extensive analysis using the Statistical Package for the Social Sciences and an independent clustering algorithm. The data analyses were used to test six different hypotheses concerning job satisfaction. Three of the hypotheses represented standard issues which had received attention in previous research. The remaining three hypotheses were specific to the model being investigated.

In this chapter the results of the analyses are summarized and the findings are discussed. The conclusions drawn from the study are presented along with a brief discussion regarding their implications for job design. The chapter concludes with recommendations for future research.

Findings Related to the Major Hypotheses

The first hypothesis concerned testing for a significant increase in job satisfaction as age, longevity, and rank increased. As expected, the data indicated that older workers who have more time in the Air Force are more satisfied than their younger counterparts. This is a common conclusion of job satisfaction research and it indicates that, at least in this regard, the sample surveyed in this study is typical of American workers. The third part of the first hypothesis examined the relationship between

military rank and job satisfaction. The prediction was that respondents holding the rank of major would have significantly higher satisfaction levels than captain respondents. The data did not support this hypothesis. Discrepancy theory provides a possible explanation for this result. If the individuals who have higher rank desire more challenge, authority, responsibility, and other intrinsic outcomes from their jobs and do not find them, job satisfaction may not increase just as a result of the higher rank.

It is possible also that, since it represented only two adjacent ranks in the military hierarchy, the sample was too limited to properly test the hypothesis. Indeed, an Air Force wide survey in 1975 showed the job satisfaction of majors (mean Hoppock score approximately 18.6) and captains (mean Hoppock score approximately 18.3) to be very similar (Thompson, 1975). Due to the large number of respondents, the difference was statistically significant. However, this writer believes that a difference of only 0.3 has no practical significance in a scale which has a possible range of 24. Therefore, based on this and other research, this writer concludes that there is no difference in the job satisfaction levels of captains and majors. Further generalization is not warranted by this research.

The second hypothesis predicted that job satisfaction would correlate negatively with education level. Sixteen of the 20 MSQ facets did have small negative correlations with education, but none were statistically significant. Therefore, the data did not support the hypothesis. Viewed in light of the sample, this result is logical. Many Air Force officers appear to view obtaining an advanced degree as "filling a square" which will improve their promotion potential. Since no one in the sample

had ever been passed over or deferred promotion, there would be no one who would have felt that the Air Force did not provide the expected reward for obtaining an advanced degree. Therefore it is reasonable that there would not be any strong relationship between job satisfaction and education level for this sample. This lack of relationship very likely extends beyond the sample surveyed for this research. Reely (1976) similarly failed to find support for this hypothesis in a similar study of Air University faculty members.

The third hypothesis was that job satisfaction would be different for the subgroups defined by aeronautical rating: pilots, navigators, and non-rated officers. The data supported this hypothesis indicating that non-rated officers were more satisfied with almost every area surveyed. The data further indicated that the job satisfaction was lowest for the pilots in the sample. An analysis of the sample provides several plausible reasons for these results.

For approximately the past two years, the American airline industry has experienced an economic upswing. This, coupled with the retirement of many of the World War II generation of airline pilots, has led to a very large surge in airline hiring. From an equity theory standpoint, any Air Force pilot who compares the economic rewards of the Air Force with those of the airlines undoubtedly perceives inequity. After approximately the first year of airline employment, an airline pilot receives from two to three times as large a salary as an Air Force pilot. Furthermore, most pilots perceive airline flying to be much less demanding than Air Force flying.

A second possible factor leading to the observed results is the very nature of a rated officer's job. Pilot training and navigator training

are very rigorous programs and only those officers who possess some rather specialized abilities and sincere desire are allowed to graduate. Following this rigorous training, pilots and navigators are assigned to operational units in which being outstanding fliers is not sufficient to receive outstanding performance reports. In order for rated officers to improve their promotion potential they must take "additional duties" which very often have little or no relation to their flying duties. In many cases the additional duties take on such importance that flying is relegated to a secondary position.

Finally, the promotion preference given to pilots applies only to the higher ranks--colonel and general. It is likely that the non-rated officers surveyed in this study had not experienced the promotion inequities which exist for the much higher grades. Consequently, those inequities probably were not perceived as factors in their job satisfaction levels.

The fourth hypothesis posited that work outcomes would cluster into three areas of the work environment. The data did not provide clear support for this hypothesis. The proposed outcome clusters consist of one intrinsic group--job properties outcomes--and two extrinsic groups--interaction features and organizational policy outcomes. The data analysis did produce an intrinsic cluster and a social environment type of cluster, but beyond that the analysis was ambiguous.

Due to failure of the questionnaire to measure a cross section of the types of outcomes, this result cannot be taken to refute the hypothesis. Further research is needed to properly test this hypothesis.

The fifth hypothesis stated that job facet satisfactions would cluster into three areas. The data supported the hypothesis. The analyses identified three clusters which matched very closely the predicted results.

The intrinsic facet satisfactions clustered into a group relating to the job properties. The extrinsic satisfactions formed two clusters: interaction features and organization policies. These results agree with previous research which was reported in some detail in Chapter II (Friedlander, 1963; Katz and Van Maanen, 1977; Mustafa and Sylvia, 1975). The implications of this result are discussed in the following section.

The sixth hypothesis investigated the relationship of the three facet satisfaction clusters to overall job satisfaction. The data indicated rather clearly that the job properties facets contribute most to overall satisfaction, and the organization policies facets contribute the least. The finding that the intrinsic factors have the strongest relationship with overall satisfaction is supportive of a great deal of previous research (Hackman and Lawler, 1971; Meyers, 1964; Reely, 1976; Wernimont, 1966).

It is significant that interaction features satisfactions are more important to overall satisfaction than organization policies satisfactions. This relationship has been noted by past researchers, but due to their more narrow focus on an intrinsic-extrinsic dichotomy they did little more than question where the interpersonal type satisfactions should be grouped (Pritchard and Peters, 1974; Reely, 1976).

Conclusions of the Study

Prior to enumerating the conclusions and implications of this study, one further comment concerning the sample is in order. The limitations of the sample were presented in detail in Chapter III. In that discussion, the writer cautioned against unrestrained generalization of this study's results because of the select nature of the ACSC students and the student status of all respondents. One important strength of the sample, however,

was the fact that it represented a broad cross section of Air Force careers and backgrounds. After extensive and detailed data analysis and comparison of these results with other research on job satisfaction, it appears the sample is more representative of a larger population than was first thought. Specifically, this writer believes that the results of this study can safely be generalized to all Air Force officers with five to thirteen years of service. This group, captains and junior majors, constitutes the middle management of the Air Force. This population represents a critical personnel resource; a resource which must be properly managed if the Air Force is to be an effective and efficient service.

The hypotheses investigated and the data analyses provided the bases for the following conclusions.

1. Job satisfaction is higher for older officers who have more time in the service. However, there is no relationship between military rank and job satisfaction for captains and majors.

2. There is no evidence of relationship between education level and job satisfaction.

3. Job satisfaction differs by aeronautical rating with non-rated officers being most satisfied and pilots being least satisfied.

4. Work environment facet satisfactions are interpreted by individuals to be grouped into three clusters: job properties, interaction features, and organization policy variables.

5. The three clusters of facet satisfactions vary in importance to overall job satisfaction with job properties satisfactions being most important and organization policies being least important.

The last two conclusions provide support for the job satisfaction model presented in Chapter III. Due to limitations of the questionnaire,

failure to support the clustering of objective outcomes is not seen as refuting the model.

Implications for Job Design

The support for the three cluster model of facet satisfactions has two implications for job design. The first, and most obvious, is that managers must attend to all three areas of the work environment. Raising an employee's pay may improve his or her satisfaction with job security as well as satisfaction with pay. However, it is not likely to raise that employee's satisfaction with the responsibility or creativity inherent in the job. On the contrary, attention to only one area could very likely result in undesired affects on other areas. For example, raising the level of responsibility might cause the job incumbent to feel that pay should be raised as well. Failure to take this into account could result in negative responses which tend to offset desired positive responses.

The second important implication is that, due to the differences in importance of the three satisfaction clusters, it may take a large amount of organization policy rewards to offset the negative effects of a job which is dissatisfying in the job properties area. Looking at it from the other side, jobs rich in job properties outcomes may be satisfying in spite of few or negative organization policy outcomes. This may be fortunate for Air Force managers since they have little or no control over the organization policy outcomes awarded to their subordinates. By taking steps to improve the intrinsic outcomes available, perhaps Air Force managers can improve the level of job satisfaction among their subordinates.

Areas for Future Research

The results of this study lead to two recommendations for future

research. First, since this study failed to reach any conclusions concerning the clustering of objective work environment outcomes, research is still needed in that area. Second, this writer recommends broadening the generalizability of the three cluster model by repeating this study using a different sample. Ideally the study should be performed using a sample representative of all Air Force personnel.

Bibliography

- Adams, J. S. "Toward an Understanding of Inequity," Journal of Abnormal and Social Psychology 67 (5): 422-436 (1963).
- "Inequity in Social Exchange," Advances in Experimental Social Psychology, Volume 2, edited by L. Berkowitz. New York: Academic Press, 1965.
- Alderfer, C. P. Existence, Relatedness, and Growth. New York: Free Press, 1972.
- Boneau, C. A. "The Effects of Violations of Assumptions Underlying the T-Test," Psychological Bulletin, 57 (1): 49-64 (1960).
- Brayfield, A. H. and W. H. Crockett. "Employee Attitudes and Employee Performance," Psychological Bulletin, 52 (5): 396-424 (1955).
- Brief, A. P. and R. J. Aldag. "The Intrinsic-Extrinsic Dichotomy: Toward Conceptual Clarity," Academy of Management Review, 2 (3): 496-500 (1977).
- Broedling, L. A. "The Uses of the Intrinsic-Extrinsic Distinction in Explaining Motivation and Organizational Behavior," Academy of Management Review, 2 (2): 267-276 (1977).
- Campbell, J. P., M. D. Dunnette, E. E. Lawler III, and K. E. Weick Jr. Managerial Behavior, Performance, and Effectiveness. New York: McGraw-Hill, 1970.
- Cummings, T. G. and J. Bigelow. "Satisfaction, Job Involvement, and Intrinsic Motivation: An Extension of Lawler and Hall's Factor Analysis," Journal of Applied Psychology, 61 (4): 523-525 (1976).
- Dachler, H. P. and B. Schneider. "Some General Considerations About Factors Affecting Job Stability and Personnel Retention." Department of Psychology, University of Maryland, College Park, MD, Report No. 20, ONR Contract No. N00014-67-A-0239-0025, 1978. (AD A055-881).
- Daspit, P. F. "An Integration of Contemporary Theories of Work Motivation: A Proposed Model and Partial Test with Implications for Job Design." Unpublished MS Thesis, Air Force Institute of Technology, Wright-Patterson Air Force Base, OH, September 1978.
- Dixon, W. B. "An Examination of Two Constructs: Organization Membership Satisfaction and Job Performance Satisfaction." Unpublished MS Thesis, Air Force Institute of Technology, Wright-Patterson Air Force Base, OH, September 1979.
- Dunham, R. B., F. J. Smith, and R. S. Blackburn. "Validation of the Index of Organizational Reactions with the JDI, the MSQ, and Faces Scales," Academy of Management Journal, 20 (3): 420-432 (1977).

- Dunnette, M. D., J. P. Campbell, and M. D. Hakel. "Factors Contributing to Job Satisfaction and Job Dissatisfaction in Six Occupational Groups," Organizational Behavior and Human Performance, 2: 143-174 (1967).
- Dyer, L. and D. F. Parker. "Classifying Outcomes in Work Motivation Research: An Examination of the Intrinsic-Extrinsic Dichotomy," Journal of Applied Psychology, 60 (4): 455-458 (1975).
- Friedlander, F. "Underlying Sources of Job Satisfaction," Journal of Applied Psychology, 47 (4): 246-250 (1963).
- "Motivations to Work and Organizational Performance," Journal of Applied Psychology, 50 (2): 143-152 (1966).
- Gillet, B. and D. P. Schwab. "Convergent and Discriminant Validities of Corresponding Job Descriptive Index and Minnesota Satisfaction Questionnaire Scales," Journal of Applied Psychology, 60 (3): 313-317 (1975).
- Glenn, N. D., P. A. Taylor, and C. N. Weaver. "Age and Job Satisfaction Among Males and Females: A Multivariate, Multisurvey Study," Journal of Applied Psychology, 62 (2): 189-193 (1977).
- Greene, C. N. "The Satisfaction-Performance Controversy," Business Horizons, 15 (5): 31-41 (1972).
- Gruneberg, M. M. (editor). Job Satisfaction--A Reader. New York: Wiley and Sons, 1976.
- Guilford, J. P. Psychometric Methods (Second Edition). New York: McGraw-Hill, 1954.
- Guzzo, R. A. "Types of Rewards, Cognitions, and Work Motivation," Academy of Management Review, 4 (1): 75-86 (1979).
- Hackman, J. R. and E. E. Lawler III. "Employee Reactions to Job Characteristics," Journal of Applied Psychology, 55 (3): 259-286 (1971).
- Hackman, J. R. and G. R. Oldham. "The Job Diagnostic Survey: An Instrument for the Diagnosis of Jobs and the Evaluation of Job Redesign Projects." Department of Administrative Sciences, Yale University, New Haven, CT, Technical Report No. 4, ONR Contract No. N00014-67A-0097-0026 (1974). (AD 779-828).
- "Development of the Job Diagnostic Survey," Journal of Applied Psychology, 60 (2): 159-170 (1975).
- "Motivation Through the Design of Work: Test of a Theory," Organizational Behavior and Human Performance, 16: 250-279 (1976).
- Hall, D. T. and K. E. Nougaim. "An Examination of Maslow's Need Hierarchy in an Organizational Setting," Organizational Behavior and Human Performance, 3: 12-35 (1968).

- Herzberg, F. Work and the Nature of Man. Cleveland: World Publishing, 1966.
- "One More Time: How Do You Motivate Employees," Harvard Business Review, 46 (1): 53-62 (1968).
- The Managerial Choice: To Be Efficient and To Be Human. Homewood, IL: Dow Jones-Irwin, 1976.
- Herzberg, F., B. Mausner, R. O. Peterson, and D. F. Capwell. Job Attitudes: Review of Research and Opinion. Pittsburgh: Psychological Services of Pittsburgh, 1957.
- Herzberg, F., B. Mausner, and B. B. Snyderman. The Motivation to Work. New York: Wiley and Sons, 1959.
- Homans, G. C. Social Behavior: Its Elementary Forms. New York: Harcourt, Brace, and World, 1961.
- Hoppock, R. Job Satisfaction. New York: Harper and Row, 1935.
- House, R. J. and L. A. Wigdor. "Herzberg's Dual-Factor Theory of Job Satisfaction and Motivation: A Review of the Evidence and a Criticism," Personnel Psychology, 20: 369-389 (1967).
- Hulin, C. L. and M. R. Blood. "Job Enlargement, Individual Differences, and Worker Responses," Psychological Bulletin, 69 (1): 41-55 (1968).
- Hulin, C. L. and P. C. Smith. "A Linear Model of Job Satisfaction," Journal of Applied Psychology, 49 (3): 209-216 (1965).
- Jacques, E. Equitable Payment. New York: Wiley and Sons, 1961.
- Kalleberg, A. L. "Work Values and Job Rewards: A Theory of Job Satisfaction," American Sociological Review, 42 (1): 124-143 (1977).
- Katz, R. and J. Van Maanen. "The Loci of Work Satisfaction: Job, Interaction, and Policy," Human Relations, 30 (5): 469-486 (1977).
- Katzell, R. A. "Personal Values, Job Satisfaction, and Job Behavior," Man in a World at Work, edited by H. Borow. Boston: Houghton Mifflin, 1964.
- Keys, A., et al. The Biology of Human Starvation, Volume II. Minneapolis: University of Minnesota Press, 1950.
- King, N. "Clarification and Evaluation of the Two-Factor Theory of Job Satisfaction," Psychological Bulletin, 74 (1): 18-31 (1970).
- Landy, F. J. and D. A. Trumbo. Psychology of Work Behavior. Homewood, IL: Dorsey, 1976.
- Lane, I. M. and L. A. Messe. "Distribution of Insufficient, Sufficient, and Oversufficient Rewards: A Clarification of Equity Theory," Journal of Personality and Social Psychology, 21 (2): 228-233 (1972).

- Lawler, E. E. III. "Job Attitudes and Employee Motivation: Theory, Research, and Practice," Personnel Psychology, 23: 223-237 (1970).
- . Motivation in Work Organizations. Monterey, CA: Brooks/Cole, 1973.
- Lawler, E. E. III and D. T. Hall. "Relationship of Job Characteristics to Job Involvement, Satisfaction, and Intrinsic Motivation," Journal of Applied Psychology, 54 (4): 305-312 (1970).
- Lawler, E. E. III and L. W. Porter. "The Effect of Performance on Job Satisfaction," Industrial Relations, 7 (1): 20-28 (1967).
- Lawler, E. E. III and J. L. Suttle. "A Causal Correlational Test of the Need Hierarchy Concept," Organizational Behavior and Human Performance, 7: 265-287 (1972).
- Lewin, K. A Dynamic Theory of Personality. New York: McGraw-Hill, 1935.
- Litwin, G. H. and R. A. Stringer, Jr. "Motivation and Behavior," Motivation and Work Behavior, edited by R. M. Steers and L. W. Porter. New York: McGraw-Hill, 1975.
- Locke, E. A. "What is Job Satisfaction?" Organizational Behavior and Human Performance, 4: 309-336 (1969).
- . "The Nature and Causes of Job Satisfaction," Handbook of Industrial and Organizational Psychology, edited by M. D. Dunnette. Chicago: Rand McNally, 1976.
- Maslow, A. H. "A Theory of Human Motivation," Psychological Review, 50 (4): 370-396 (1943).
- . Motivation and Personality. New York: Harper and Row, 1954.
- . Toward a Psychology of Being (Second Edition). New York: Van Nostrand Reinhold, 1968.
- . Motivation and Personality (Second Edition). New York: Harper and Row, 1970.
- McClelland, D. C. The Achieving Society. Princeton, NJ: Van Nostrand, 1961.
- . "Toward a Theory of Motive Acquisition," American Psychologist, 20: 321-333 (1965).
- . "That Urge to Achieve," Think, 32 (6): 19-23 (1966).
- McNichols, C. W. "An Introduction to: Applied Multivariate Data Analysis," (Draft). Unpublished Course Notes, SM 6.85, Air Force Institute of Technology, Wright-Patterson Air Force Base, OH, 1978a.
- McNichols, C. W. "ACLU- An Agglomerative Clustering Algorithm." Unpublished Course Notes, SM 6.85, Air Force Institute of Technology, Wright-Patterson Air Force Base, OH, 1978b.

- McNichols, C. W., M. J. Stahl, and T. R. Manley. "A Validation of Hoppock's Job Satisfaction Measure," Academy of Management Journal, 21 (4): 737-742 (1978).
- Mendenhall, W. and R. L. Scheaffer. Mathematical Statistics with Applications. North Scituate, MA: Duxbury Press, 1973.
- Meyers, M. S. "Who Are Your Motivated Workers?" Harvard Business Review, 42 (1): 73-80 (1964).
- Mitchell, T. R. "Expectancy Models of Job Satisfaction, Occupational Preference and Effort: A Theoretical, Methodological, and Empirical Appraisal," Psychological Bulletin, 81 (12): 1053-1077 (1974).
- Murray, H. A. Explorations in Personality. New York: Oxford University Press, 1938.
- Mustafa, H. and R. D. Sylvia. "A Factor-Analysis Approach to Job Satisfaction," Public Personnel Management, 4 (1): 165-172 (1975).
- Nie, N. H., et al. Statistical Package for the Social Sciences (Second Edition). New York: McGraw-Hill, 1975.
- Nunnally, J. C. Psychometric Theory. New York: McGraw-Hill, 1967.
- Patchen, M. The Choice of Wage Comparisons. Englewood Cliffs, NJ: Prentice-Hall, 1961.
- Porter, L. W. and E. E. Lawler III. Managerial Attitudes and Performance. Homewood, IL: Richard D. Irwin, 1968.
- Porter, L. W., E. E. Lawler III, and J. R. Hackman. Behavior in Organizations. New York: McGraw-Hill, 1975.
- Porter, L. W. and R. M. Steers. "Organizational, Work, and Personal Factors in Employee Turnover and Absenteeism," Psychological Bulletin, 80 (2): 151-176 (1973).
- Pritchard, R. D. "Equity Theory: A Review and Critique," Organizational Behavior and Human Performance, 4: 176-211 (1969).
- Pritchard, R. D., M. D. Dunnette, and D. O. Jorgenson. "Effects of Wage Equity and Inequity on Job Performance and Job Satisfaction." Technical Report No. 4002, Center for the Study of Organizational Performance and Human Effectiveness, University of Minnesota, Minneapolis, MN, 1970. (AD 713-976).
- Pritchard, R. D. and L. H. Peters. "Job Duties and Job Interests as Predictors of Intrinsic and Extrinsic Satisfaction," Organizational Behavior and Human Performance, 12: 315-330 (1974).
- Pritchard, R. D. and J. B. Shaw. "Comparison of Published Measures of Job Satisfaction on a Taxonomy of Job Rewards." Purdue Research Foundation, West Lafayette, IN, Report No. AFHRL-TR-78-21, AFOSR Grant 76-2873, 1978. (AD A058-138).

- Reely, R. H. Jr. "An Analysis of the Relationships Between Job Satisfaction/Enrichment Factors and Demographic Variables for United States Air Force Professional Military Education Faculty." Unpublished PhD Dissertation, Auburn, AL: Auburn University, 1976. (AD A031-821).
- Roethlisberger, F. J. and W. J. Dixon. Management and the Worker. Cambridge, MA: Harvard University Press, 1939.
- Salancik, G. R. and J. Pfeffer. "An Examination of Need Satisfaction Models of Job Attitudes," Administrative Science Quarterly, 22 (3): 427-455 (September 1977).
- Saleh, S. D. and J. Hyde. "Trends in Job Satisfaction along the Age Dimension," Experimental Publication System, American Psychological Association, 1: Ms. 33, 1969.
- Schaffer, R. H. "Job Satisfaction as Related to Need Satisfaction in Work," Psychological Monographs, 67 (14 Whole No. 364): (1953).
- Seashore, S. E. and T. D. Taber. "Job Satisfaction Indicators and Their Correlates," American Behavioral Scientist, 18 (3): 333-368 (1975).
- Smith, F. J. "Work Attitudes as Predictors of Attendance on a Specific Day," Journal of Applied Psychology, 62 (1): 16-19 (1977).
- Smith, P. C., L. M. Kendall, and C. L. Hulin. Measurement of Satisfaction in Work and Retirement. Chicago: Rand McNally, 1969.
- Special Task Force to the Secretary of Health, Education, and Welfare. Work in America. Cambridge, MA: MIT Press, 1973.
- Stahl, M. J., G. C. S. Young, and P. S. Scoville. "A Dichotomous Test of a Dichotomous Theory: An Application of the Automatic Interaction Detector (AID) Algorithm to Testing Herzberg's Two-Factor Theory of Job Satisfaction," Proceedings, American Institute of Decision Sciences: 283-285 (October 1977).
- Steers, R. M. "Effects of Need for Achievement on the Job Performance-Job Attitude Relationship," Journal of Applied Psychology, 60 (6): 678-682 (1975).
- , "Factors Affecting Job Attitudes in a Goal-Setting Environment," Academy of Management Journal, 19 (1): 6-16 (1976).
- Steers, R. M. and R. T. Mowday. "The Motivational Properties of Tasks," Academy of Management Review, 2 (4): 645-658 (1977).
- Steers, R. M. and L. W. Porter. Motivation and Work Behavior. New York: McGraw-Hill, 1975.
- Steers, R. M. and S. R. Rhodes. "Major Influences on Employee Attendance: A Process Model," Journal of Applied Psychology, 63 (4): 391-407 (1978).

- Steers, R. M. and D. G. Spencer. "The Role of Achievement Motivation in Job Design," Journal of Applied Psychology, 62 (4): 472-479 (1977).
- Stinson, J. E. and T. W. Johnson. "Tasks, Individual Differences and Job Satisfaction," Industrial Relations, 16 (3): 315-322 (1977).
- Stone, E. F., R. T. Mowday, and L. W. Porter. "Higher Order Need Strengths as Moderators of the Job Scope-Job Satisfaction Relationship," Journal of Applied Psychology, 62 (4): 466-471 (1977).
- Taylor, F. W. The Principles of Scientific Management. New York: Harper, 1911.
- Thompson, T. N. "A Study of Job Satisfaction in the United States Air Force." Unpublished MS Thesis, Air Force Institute of Technology, Wright-Patterson Air Force Base, OH, 1975.
- Tolman, E. C. Purposive Behavior in Animals and Men. New York: Century Co., 1932.
- Turner, A. N. and P. R. Lawrence. Industrial Jobs and the Worker. Boston: Harvard University Press, 1965.
- Vroom, V. H. Work and Motivation. New York: Wiley and Sons, 1964.
- Wanous, J. P. "Who Wants Job Enrichment," Perspectives on Behavior in Organizations, edited by J. R. Hackman, et al. New York: McGraw-Hill, 1977.
- Wanous, J. P. and E. E. Lawler III. "Measurement and Meaning of Job Satisfaction," Journal of Applied Psychology, 56 (2): 95-105 (1972).
- Weick, K. E. and B. Nessel. "Preferences Among Forms of Equity," Organizational Behavior and Human Performance, 3: 400-416 (1968).
- Weiss, D. J., R. V. Dawis, G. W. England, and L. H. Lofquist. Manual for the Minnesota Satisfaction Questionnaire (Minnesota Studies in Vocational Rehabilitation: XXII). Minneapolis: University of Minnesota, Industrial Relations Center, Work Adjustment Project, 1967.
- Wernimont, P. F. "Intrinsic and Extrinsic Factors in Job Satisfaction," Journal of Applied Psychology, 50 (1): 41-50 (1966).
- Wolf, A. V. Thirst: Physiology of the Urge to Drink and Problems of Water Lack. Springfield, IL: Charles C. Thomas, 1958.

Appendix A

Survey Instrument

MEMBERSHIP-PERFORMANCE QUESTIONNAIRE

EXPECTED COMPLETION TIME: 20 MINUTES

Purpose of the Study

The Air Force Institute of Technology is conducting a scientific study of the relationships between job performance satisfaction, organization membership satisfaction, and overall job satisfaction. This research will be used to analyze a model of the sources of job satisfaction, with a long range goal of improving the design of work environments.

You have been selected as part of a sample of Air University students. Any answers you provide will be strictly confidential and seen only by Air Force Institute of Technology researchers. No individual information will be given to anyone outside the research team. The results of this research will be presented in two master's theses.

Select one answer to each question, then mark your answer on the separate answer sheet. Please use a No. 2 pencil.

Be sure to mark your answers carefully so that you place them beside the same answer sheet number as survey question number.

Be sure that your answer marks are heavy and that you blacken the entire space.

SOS Students: Please return answer sheets to the wing secretary by 1100 hours, Wednesday, 23 May 1979.

ACSC Students: Please return answer sheets to the evaluation box in the central hall by 1100 hours, Wednesday 23 May 1979.

Privacy Statement

In accordance with paragraph 30, AFR 12-35, Air Force Privacy Program, the following information about this survey is provided:

- a. Authority. 10 U.S.C., 8012, Secretary of the Air Force: Powers and Duties, Delegation by.
- b. Principal purpose. The survey is being conducted to collect opinions and behavioral information relating to current and future Air Force policies and programs.
- c. Routine use. The survey data will be converted to statistical information for use by Air Force Institute of Technology researchers.
- d. Participation in this survey is voluntary.
- e. No adverse action of any kind may be taken against any individual who elects not to participate in this survey.

Copyright

Section II, The Minnesota Satisfaction Questionnaire, Copyright 1967, is used by permission of the Vocational Psychology Research, University of Minnesota.

BCN 79-95

SECTION I

This section of the questionnaire is designed to measure the degree to which certain properties exist in your work environment. Please mark the letter on your answer sheet which indicates the extent that the property is present in your work environment. Answer each question as it pertains to the job you held longest at your duty station immediately prior to attending this school.

Example: A C-9 (Medivac) flight attendant might answer the following example question in this manner:

Ex. To what extent does your work situation provide you the opportunity to serve others?

A B C D **E**

Very little. My work situation does not allow me to help others.

Moderately. My work situation provides some opportunity to help others.

I continuously have chances to help/serve others.

1. To what extent does your work situation provide you the opportunity to serve others?

A B C D E

Very little. My work situation does not allow me to help others.

Moderately. My work situation provides some opportunity to help others.

I continuously have chances to help/serve others.

2. To what extent does your work environment allow you to be creative? That is, can you try out new and better ways to do the job?

A B C D E

Very little. I have little or no opportunity to try out my own ideas.

Moderately. Some aspects of my work situation allow me freedom to decide how things are done.

I have almost complete freedom to decide how things are done or to try out new ideas.

3. How often does your work environment require you to do things that go against your conscience?

A B C D E

My job never requires me to do things I feel are morally wrong.

Occasionally. I sometimes must do things that go against my conscience.

Very often. I am often required to do things I feel are morally wrong.

4. How much independence is there in your work environment? That is, to what extent can you do your work on your own?

A B C D E

Very little. In my work environment there is almost nothing I can do independent of others.

I work with others and independently of others about equally in my work environment.

In my work situation I almost always work independently of others.

5. How much variety is there in your work situation? That is, to what extent are you able to do many different things at work, using a variety of your skills and talents?

A B C D E

Very little. I do the same routine things over and over again.

Moderate variety.

Very much. I am able to do many different things, using a number of different skills and talents.

6. How much authority do you have in your work environment? To what extent do other workers look to you for direction?

A B C D E

Very little. The situation does not allow me to influence the activities of others.

I am able to influence some of the activities of others.

Very much. My work situation gives me almost complete authority over the activities of many others.

7. To what extent does your work situation make use of your abilities and skills?

A B C D E

Very little. I seldom have the chance to do things that are suited to my abilities and skills.

I sometimes have the chance to make use of my abilities and skills.

Very much. Most of the time I have the opportunity to do things that are well suited to my abilities and skills.

8. How much social status results from your work situation? That is, how much opportunity do you have to be important in the eyes of others?

A B C D E

Very little. My work situation provides almost no opportunity to be important in the eyes of others.

Moderate social status.

Very much. High social status is inherent in my work situation.

9. How much opportunity for advancement is there in your work environment?

A B C D E

Very little. Opportunity for advancement in my work situation does not exist.

Moderate. My chance for advancement is about average.

Very much. My environment provides a great deal of opportunity for upward mobility.

10. In your work situation, to what extent do managers or co-workers let you know how well you are doing?

A B C D E

Very little. People almost never let me know how well I am doing.

Moderately. Sometimes people may give me feedback; other times they may not.

Very much. Managers or co-workers provide me with almost constant feedback about how well I am doing.

11. To what extent does your work situation give you a feeling of accomplishment--that you completed something worthwhile?

A B C D E

I almost never receive a feeling of achievement from my work situation.

My work situation provides me moderate feelings of achievement.

I almost always associate feelings of achievement with my work situation.

12. To what extent does your work environment provide the opportunity to keep busy most of the time?

A B C D E

Very little. A large part of the time I have nothing to do.

Moderate. My activity and workload are about average.

Very much. I could keep busy all the time.

SECTION II

The purpose of this section is to measure how you feel about your job, what things you are satisfied with and what things you are not satisfied with. Answer each question as it pertains to the job you held longest at your duty station prior to attending this school. Decide how you feel about the aspect of your job described by the statement, and mark your answer sheet beginning in number 13. Answer:

- (a) if you are not satisfied (if that aspect is much poorer than you would like it to be);
- (b) if you are only slightly satisfied (if that aspect is not quite what you would like it to be);
- (c) if you are satisfied (if that aspect is what you would like it to be);
- (d) if you are very satisfied (if that aspect is even better than you expected it to be);
- (e) if you are extremely satisfied (if that aspect is much better than you hoped it could be).

Do not turn back to previous statements.

On my job, this is how I feel about . . .

- 13. The chance to be of service to others A B C D E
- 14. The chance to try out some of my own ideas A B C D E
- 15. Being able to do the job without feeling it is
morally wrong A B C D E
- 16. The chance to work by myself A B C D E
- 17. The variety in my work A B C D E
- 18. The chance to have other workers look to me for
direction A B C D E
- 19. The chance to do the kind of work I do best A B C D E
- 20. The social position in the community that goes with
the job A B C D E
- 21. The policies and practices of the Air Force toward
its members A B C D E
- 22. The way my supervisor and I understand each other A B C D E
- 23. My job security A B C D E

Ask yourself: How satisfied am I with this aspect of my job?

- (a) means I am not satisfied (this aspect of my job is much poorer than I would like it to be);
- (b) means I am only slightly satisfied (this aspect of my job is not quite what I would like it to be);
- (c) means I am satisfied (this aspect of my job is what I would like it to be);
- (d) means I am very satisfied (this aspect of my job is even better than I expected it to be);
- (e) means I am extremely satisfied (this aspect of my job is much better than I hoped it could be).

On my job, this is how I feel about . . .

- 24. The amount of pay for the work I do A B C D E
- 25. The working conditions (heating, lighting, ventilation, etc.) on this job A B C D E
- 26. The opportunities for advancement on this job A B C D E
- 27. The technical "know-how" of my supervisor A B C D E
- 28. The spirit of cooperation among my co-workers A B C D E
- 29. The chance to be responsible for planning my work A B C D E
- 30. The way I am noticed when I do a good job A B C D E
- 31. Being able to see the results of the work I do A B C D E
- 32. The chance to be active much of the time A B C D E
- 33. The chance to be of service to people A B C D E
- 34. The chance to do new and original things on my own A B C D E
- 35. Being able to do things that don't go against my religious beliefs A B C D E
- 36. The chance to work alone on the job A B C D E
- 37. The chance to do different things from time to time A B C D E
- 38. The chance to tell other workers how to do things A B C D E
- 39. The chance to do work that is well suited to my abilities A B C D E
- 40. The chance to be "somebody" in the community A B C D E
- 41. Air Force policies and the way in which they are administered A B C D E

Ask yourself: How satisfied am I with this aspect of my job?

- (a) means I am not satisfied (this aspect of my job is much poorer than I would like it to be);
- (b) means I am only slightly satisfied (this aspect of my job is not quite what I would like it to be);
- (c) means I am satisfied (this aspect of my job is what I would like it to be);
- (d) means I am very satisfied (this aspect of my job is even better than I expected it to be);
- (e) means I am extremely satisfied (this aspect of my job is much better than I hoped it could be).

On my job, this is how I feel about . . .

- 42. The way my boss handles subordinates A B C D E
- 43. The way my job provides for a secure future A B C D E
- 44. The chance to make as much money as my friends A B C D E
- 45. The physical surroundings where I work A B C D E
- 46. The chances of getting ahead on this job A B C D E
- 47. The competence of my supervisor in making decisions A B C D E
- 48. The chance to develop close friendships with my
co-workers A B C D E
- 49. The chance to make decisions on my own A B C D E
- 50. The way I get full credit for the work I do A B C D E
- 51. Being able to take pride in a job well done A B C D E
- 52. Being able to do something much of the time A B C D E
- 53. The chance to help people A B C D E
- 54. The chance to try something different A B C D E
- 55. Being able to do things that don't go against my
conscience A B C D E
- 56. The chance to be alone on the job A B C D E
- 57. The routine in my work A B C D E
- 58. The chance to supervise other people A B C D E
- 59. The chance to make use of my best abilities A B C D E
- 60. The chance to "rub elbows" with important people A B C D E

Ask yourself: How satisfied am I with this aspect of my job?

- (a) means I am not satisfied (this aspect of my job is much poorer than I would like it to be);
- (b) means I am only slightly satisfied (this aspect of my job is not quite what I would like it to be);
- (c) means I am satisfied (this aspect of my job is what I would like it to be);
- (d) means I am very satisfied (this aspect of my job is even better than I expected it to be);
- (e) means I am extremely satisfied (this aspect of my job is much better than I hoped it could be).

On my job, this is how I feel about . . .

- 61. The way employees are informed about Air Force policies A B C D E
- 62. The way my boss backs up subordinates (with top management) A B C D E
- 63. The way my job provides for steady employment A B C D E
- 64. How my pay compares with that for comparable work in other organizations A B C D E
- 65. The pleasantness of the working conditions A B C D E
- 66. The way promotions are given out on this job A B C D E
- 67. The way my boss delegates work to others A B C D E
- 68. The friendliness of my co-workers A B C D E
- 69. The chance to be responsible for the work of others A B C D E
- 70. The recognition I get for the work I do A B C D E
- 71. Being able to do something worthwhile A B C D E
- 72. Being able to stay busy A B C D E
- 73. The chance to do things for other people A B C D E
- 74. The chance to develop new and better ways to do the job A B C D E
- 75. The chance to do things that don't harm other people A B C D E
- 76. The chance to work independently of others A B C D E
- 77. The chance to do something different every day A B C D E
- 78. The chance to tell people what to do A B C D E
- 79. The chance to do something that makes use of my abilities A B C D E

Ask yourself: How satisfied am I with this aspect of my job?

- (a) means I am not satisfied (this aspect of my job is much poorer than I would like it to be);
- (b) means I am only slightly satisfied (this aspect of my job is not quite what I would like it to be);
- (c) means I am satisfied (this aspect of my job is what I would like it to be);
- (d) means I am very satisfied (this aspect of my job is even better than I expected it to be);
- (e) means I am extremely satisfied (this aspect of my job is much better than I hoped it could be).

On my job, this is how I feel about . . .

- 80. The chance to be important in the eyes of others A B C D E
- 81. The way Air Force policies are put into practice A B C D E
- 82. The way my boss takes care of subordinates' complaints A B C D E
- 83. How steady my job is A B C D E
- 84. My pay and the amount of work I do A B C D E
- 85. The physical working conditions of the job A B C D E
- 86. The chances for advancement on this job A B C D E
- 87. The way my boss provides help on hard problems A B C D E
- 88. The way my co-workers are easy to make friends with A B C D E
- 89. The freedom to use my own judgment A B C D E
- 90. The way they usually tell me when I do my job well A B C D E
- 91. The chance to do my best at all times A B C D E
- 92. The chance to be "on the go" all the time A B C D E
- 93. The chance to be of some small service to other people A B C D E
- 94. The chance to try my own methods of doing the job A B C D E
- 95. The chance to do the job without feeling I am cheating anyone A B C D E
- 96. The chance to work away from others A B C D E
- 97. The chance to do many different things on the job A B C D E
- 98. The chance to tell others what to do A B C D E
- 99. The chance to make use of my abilities and skills A B C D E

Ask yourself: How satisfied am I with this aspect of my job?

- (a) means I am not satisfied (this aspect of my job is much poorer than I would like it to be);
- (b) means I am only slightly satisfied (this aspect of my job is not quite what I would like it to be);
- (c) means I am satisfied (this aspect of my job is what I would like it to be);
- (d) means I am very satisfied (this aspect of my job is even better than I expected it to be);
- (e) means I am extremely satisfied (this aspect of my job is much better than I hoped it could be).

On my job, this is how I feel about . . .

- 100. The chance to have a definite place in the community . . . A B C D E
- 101. The way the company treats its employees A B C D E
- 102. The personal relationship between my boss and subordinates A B C D E
- 103. The way forced separations are avoided in my job A B C D E
- 104. How my pay compares with that of other workers A B C D E
- 105. The working conditions A B C D E
- 106. My chances for advancement A B C D E
- 107. The way my boss trains subordinates A B C D E
- 108. The way my co-workers get along with each other A B C D E
- 109. The responsibility of my job A B C D E
- 110. The praise I get for doing a good job A B C D E
- 111. The feeling of accomplishment I get from the job A B C D E
- 112. Being able to keep busy all the time A B C D E

SECTION III

The purpose of this section of the questionnaire is to determine if you associate the presence of certain work characteristics (advancement, recognition, responsibility, etc.) with either or both of two features of your work environment. The two features of the work environment are:

- (a) Your performance of duties (where performance is defined as activity directed toward accomplishing organization goals).
- (b) Other aspects of your being a member of the organization.

Answer each question as it pertains to the position you held longest at your duty station immediately prior to attending this school. If your work environment does not exhibit a particular characteristic, such as recognition, you will be asked to skip the questions which ask about that characteristic.

Example 1. A branch chief who directly supervises several people may respond to the following questions in this manner:

1. Does your work environment provide you opportunities to interact with co-workers?

- a. Yes
- b. No

If "No", please skip to question 4.

2. Opportunities to interact with co-workers occur when I am performing my duties.

A B C D E

Strongly Disagree	Disagree	Neither Agree Nor Disagree	Agree	Strongly Agree
----------------------	----------	-------------------------------	-------	-------------------

3. Opportunities to interact with co-workers occur simply from being a member of the organization.

A B C D E

Strongly Disagree	Disagree	Neither Agree Nor Disagree	Agree	Strongly Agree
----------------------	----------	-------------------------------	-------	-------------------

Example 2. A missile combat crew member who is not required to interact extensively with others while performing alert duties but frequently discusses the state of the world with other crewmembers might answer the same questions this way.

1. Does your work environment provide you opportunities to interact with co-workers?

- a. Yes
- b. No

If "No", please skip to question 4.

2. Opportunities to interact with co-workers occur when I am performing my duties.

A **B** C D E
Strongly Disagree Disagree Neither Agree Agree Strongly
Disagree Nor Disagree Agree Agree

3. Opportunities to interact with co-workers occur simply from being a member of the organization.

A B C **D** E
Strongly Disagree Neither Agree Agree Strongly
Disagree Nor Disagree Agree Agree

113. Do opportunities to help other people occur in your work environment?

- a. Yes
- b. No

If "No", please skip to question 116.

114. Opportunities to help other people occur when I am performing my duties.

A B C D E
Strongly Disagree Neither Agree Agree Strongly
Disagree Nor Disagree Agree Agree

115. Opportunities to help other people occur simply from being a member of the organization.

A B C D E
Strongly Disagree Neither Agree Agree Strongly
Disagree Nor Disagree Agree Agree

116. Does your work environment offer you opportunities to try out some of your own ideas?

- a. Yes
- b. No

If "No", please skip to question 119.

117. Opportunities to try out some of my own ideas occur when I performing my duties.

A B C D E
Strongly Disagree Neither Agree Agree Strongly
Disagree Nor Disagree Agree Agree

118. Opportunities to try out some of my own ideas occur simply from being a member of the organization.

A B C D E
Strongly Disagree Neither Agree Agree Strongly
Disagree Nor Disagree Agree Agree

119. Does your work environment require you to do things that go against your conscience?

- a. Yes
- b. No

If "No", please skip to question 122.

120. Requirements to do things that go against my conscience occur when I am performing my duties.

A B C D E
Strongly Disagree Disagree Neither Agree Agree Strongly
Disagree Nor Disagree Agree Agree

121. Requirements to do things that go against my conscience occur simply from being a member of the organization.

A B C D E
Strongly Disagree Neither Agree Agree Strongly
Disagree Nor Disagree Agree Agree

122. Does your work environment offer you opportunities to work independently of others?

- a. Yes
- b. No

If "No", please skip to question 125.

123. Opportunities to work independently of others occur when I am performing my duties.

A B C D E
Strongly Disagree Neither Agree Agree Strongly
Disagree Nor Disagree Agree Agree

PLEASE ENSURE YOU ARE MARKING ANSWERS FOR THE CORRECT QUESTION NUMBER ON THE ANSWER SHEET.

124. Opportunities to work independently of others occur simply from being a member of the organization.

A B C D E
Strongly Disagree Neither Agree Agree Strongly
Disagree Nor Disagree Agree Agree

125. Does your work environment offer you opportunities to do many different things?

- a. Yes
- b. No

If "No", please skip to question 128.

126. Opportunities to do many different things occur when I am performing my duties.

A B C D E
Strongly Disagree Disagree Neither Agree Agree Strongly
Disagree Nor Disagree Agree Agree

127. Opportunities to do many different things occur simply from being a member of the organization.

A B C D E
Strongly Disagree Disagree Neither Agree Agree Strongly
Disagree Nor Disagree Agree Agree

128. Does your work environment offer you opportunities to have others look to you for direction?

- a. Yes
- b. No

If "No", please skip to question 131.

129. Opportunities to have others look to me for direction occur when I am performing my duties.

A B C D E
Strongly Disagree Disagree Neither Agree Agree Strongly
Disagree Nor Disagree Agree Agree

130. Opportunities to have others look to me for direction occur simply from being a member of the organization.

A B C D E
Strongly Disagree Disagree Neither Agree Agree Strongly
Disagree Nor Disagree Agree Agree

131. Does your work environment offer you opportunities to use your abilities and skills?

- a. Yes
- b. No

If "No", please skip to question 134.

132. Opportunities to use my abilities and skills occur when I am performing my duties.

A	B	C	D	E
Strongly Disagree	Disagree	Neither Agree Nor Disagree	Agree	Strongly Agree

133. Opportunities to use my abilities and skills occur simply from being a member of the organization.

A	B	C	D	E
Strongly Disagree	Disagree	Neither Agree Nor Disagree	Agree	Strongly Agree

PLEASE ENSURE YOU ARE MARKING ANSWERS FOR THE CORRECT QUESTION NUMBER ON THE ANSWER SHEET.

134. Does your work environment offer you the chance to be important in the eyes of others?

- a. Yes
- b. No

If "No", please skip to question 137.

135. The chance to be important in the eyes of others occurs when I am performing my duties.

A	B	C	D	E
Strongly Disagree	Disagree	Neither Agree Nor Disagree	Agree	Strongly Agree

136. The chance to be important in the eyes of others occurs from simply being a member of the organization.

A	B	C	D	E
Strongly Disagree	Disagree	Neither Agree Nor Disagree	Agree	Strongly Agree

137. Organizational policies and procedures are applied to me when I am performing my duties.

A B C D E
Strongly Disagree Disagree Neither Agree Agree Strongly
Disagree Nor Disagree Agree Agree

138. Organizational policies and procedures are applied to me simply from being a member of the organization.

A B C D E
Strongly Disagree Disagree Neither Agree Agree Strongly
Disagree Nor Disagree Agree Agree

139. Does your work environment provide you opportunities to personally interact with your supervisor?

- a. Yes
- b. No

If "No", please skip to question 142.

140. Opportunities to personally interact with my supervisor occur when I am performing my duties.

A B C D E
Strongly Disagree Disagree Neither Agree Agree Strongly
Disagree Nor Disagree Agree Agree

141. Opportunities to personally interact with my supervisor occur simply from being a member of the organization.

A B C D E
Strongly Disagree Disagree Neither Agree Agree Strongly
Disagree Nor Disagree Agree Agree

142. My future job security is associated with my performance of duties.

A B C D E
Strongly Disagree Disagree Neither Agree Agree Strongly
Disagree Nor Disagree Agree Agree

143. My future job security is associated with simply being a member of the organization.

A B C D E
Strongly Disagree Disagree Neither Agree Agree Strongly
Disagree Nor Disagree Agree Agree

144. My pay is associated with my performance of duties.
- | | | | | |
|----------------------|-------------|-------------------------------|-------------|-------------------|
| A | B | C | D | E |
| Strongly
Disagree | Disagree | Neither Agree
Nor Disagree | Agree | Strongly
Agree |
145. My pay is associated with simply being a member of the organization.
- | | | | | |
|----------------------|-------------|-------------------------------|-------------|-------------------|
| A | B | C | D | E |
| Strongly
Disagree | Disagree | Neither Agree
Nor Disagree | Agree | Strongly
Agree |
146. I am subject to the physical conditions of the work situation (heating, lighting, ventilation, etc.) when I am performing my duties.
- | | | | | |
|----------------------|-------------|-------------------------------|-------------|-------------------|
| A | B | C | D | E |
| Strongly
Disagree | Disagree | Neither Agree
Nor Disagree | Agree | Strongly
Agree |
147. I am subject to the physical conditions of the work situation (heating, lighting, ventilation, etc.) simply from being a member of the organization.
- | | | | | |
|----------------------|-------------|-------------------------------|-------------|-------------------|
| A | B | C | D | E |
| Strongly
Disagree | Disagree | Neither Agree
Nor Disagree | Agree | Strongly
Agree |
148. Does your work environment provide you opportunities for advancement?
- a. Yes
b. No
- If "No", please skip to question 151.
149. Opportunities for advancement are associated with my performance of my duties.
- | | | | | |
|----------------------|-------------|-------------------------------|-------------|-------------------|
| A | B | C | D | E |
| Strongly
Disagree | Disagree | Neither Agree
Nor Disagree | Agree | Strongly
Agree |
150. Opportunities for advancement are associated with being a member of the organization.
- | | | | | |
|----------------------|-------------|-------------------------------|-------------|-------------------|
| A | B | C | D | E |
| Strongly
Disagree | Disagree | Neither Agree
Nor Disagree | Agree | Strongly
Agree |

151. Does your work environment provide you opportunities to see your supervisor solve problems?

- a. Yes
- b. No

If "No", please skip to question 154.

152. Opportunities to see my supervisor solving problems occur when I am performing my duties.

A B C D E
Strongly Disagree Disagree Neither Agree Agree Strongly
Disagree Nor Disagree Agree Agree

153. Opportunities to see my supervisor solving problems occur simply from being a member of the organization.

A B C D E
Strongly Disagree Neither Agree Agree Strongly
Disagree Nor Disagree Agree Agree

PLEASE ENSURE YOU ARE MARKING ANSWERS FOR THE CORRECT QUESTION NUMBER ON THE ANSWER SHEET.

154. Does your work environment provide you opportunities to interact with your co-workers?

- a. Yes
- b. No

If "No", please skip to question 157.

155. Opportunities to interact with co-workers occur when I am performing my duties.

A B C D E
Strongly Disagree Neither Agree Agree Strongly
Disagree Nor Disagree Agree Agree

156. Opportunities to interact with co-workers occur simply from being a member of the organization.

A B C D E
Strongly Disagree Neither Agree Agree Strongly
Disagree Nor Disagree Agree Agree

157. Does your work environment offer you opportunities to make and be responsible for your own decisions?

- a. Yes
- b. No

If "No", please skip to question 160.

158. Opportunities to make and be responsible for my own decisions occur when I am performing my duties.

A	B	C	D	E
Strongly Disagree	Disagree	Neither Agree Nor Disagree	Agree	Strongly Agree

159. Opportunities to make and be responsible for my own decisions occur simply from being a member of the organization.

A	B	C	D	E
Strongly Disagree	Disagree	Neither Agree Nor Disagree	Agree	Strongly Agree

160. Does your work environment provide you opportunities to be recognized?

- a. Yes
- b. No

If "No", skip to question 163.

161. Opportunities to be recognized occur when I am performing my duties.

A	B	C	D	E
Strongly Disagree	Disagree	Neither Agree Nor Disagree	Agree	Strongly Agree

162. Opportunities to be recognized occur simply from being a member of the organization.

A	B	C	D	E
Strongly Disagree	Disagree	Neither Agree Nor Disagree	Agree	Strongly Agree

163. Does your work environment provide you a feeling of accomplishment?
 a. Yes
 b. No

If "No", please skip to question 166.

164. Opportunities to receive a feeling of accomplishment occur when I am performing my duties.

A B C D E
 Strongly Disagree Disagree Neither Agree Agree Strongly
 Disagree Nor Disagree Agree Agree

165. Opportunities to receive a feeling of accomplishment occur simply from being a member of the organization.

A B C D E
 Strongly Disagree Neither Agree Agree Strongly
 Disagree Nor Disagree Agree Agree

166. Does your work environment provide you opportunities to be active much of the time?

- a. Yes
 b. No

If "No", you have completed this section. Please begin Section IV.

167. Opportunities to be active much of the time occur when I am performing my duties.

A B C D E
 Strongly Disagree Neither Agree Agree Strongly
 Disagree Nor Disagree Agree Agree

168. Opportunities to be active much of the time occur simply from being a member of the organization.

A B C D E
 Strongly Disagree Neither Agree Agree Strongly
 Disagree Nor Disagree Agree Agree

SECTION IV

169. Which one of the following shows how much of the time you feel satisfied with your job?
- a. Never.
 - b. Seldom.
 - c. Occasionally.
 - d. About half of the time.
 - e. A good deal of the time.
 - f. Most of the time.
 - g. All the time.
170. Choose the one of the following statements which best tells how well you like your job.
- a. I hate it.
 - b. I dislike it.
 - c. I don't like it.
 - d. I am indifferent to it.
 - e. I like it.
 - f. I am enthusiastic about it.
 - g. I love it.
171. Which one of the following best tells how you feel about changing your job?
- a. I would quit this job at once if I could.
 - b. I would take almost any other job in which I could earn as much as I am earning now.
 - c. I would like to change both my job and my occupation.
 - d. I would like to exchange my present job for another one.
 - e. I am not eager to change my job, but I would do so if I could get a better job.
 - f. I cannot think of any jobs for which I would exchange.
 - g. I would not exchange my job for any other.
172. Which one of the following shows how you think you compare with other people?
- a. No one dislikes their job more than I dislike mine.
 - b. I dislike my job much more than most people dislike theirs.
 - c. I dislike my job more than most people dislike theirs.
 - d. I like my job about as well as most people like theirs.
 - e. I like my job better than most people like theirs.
 - f. I like my job much better than most people like theirs.
 - g. No one likes their job better than I like mine.

SECTION V

173. Age:
- | | | | | |
|----------|----------|----------|----------|----------|
| a. 21-22 | c. 25-26 | e. 29-30 | g. 33-34 | i. 37-38 |
| b. 23-24 | d. 27-28 | f. 31-32 | h. 35-36 | j. 39-40 |
174. Sex:
- a. Male
 - b. Female
175. Marital Status:
- | | |
|-----------------------|-------------------------------|
| a. Married | c. Divorced and not Remarried |
| b. Never been married | d. Legally separated |
| | e. Widow/widower |
176. Rank:
- | | | |
|-------|-------|-------|
| a. 01 | c. 03 | d. 05 |
| b. 02 | d. 04 | e. 06 |
177. Total Years in the Air Force:
- | | | | | |
|------|------|------|----------|----------|
| a. 2 | c. 4 | e. 6 | g. 8-10 | i. 14-16 |
| b. 3 | d. 5 | f. 7 | h. 11-13 | j. 17-19 |
178. Level of job you held immediately prior to attending this school. If you held more than one job at your previous base, relate this question to the position you considered most permanent.
- | | |
|--------------------------|------------------------------|
| a. Squadron | f. Other Joint Command |
| b. Wing | g. Separate Operating Agency |
| c. MAJCOM | h. DOD |
| d. Air Staff | i. Other |
| e. JCS/National Agencies | |
179. Aeronautical Rating:
- a. Pilot: primary flying
 - b. Pilot: primary non-flying
 - c. Navigator: primary flying
 - d. Navigator: primary non-flying
 - e. Non-rated
180. What is your highest level of education now?
- a. College degree (BA, BS, or equivalent)
 - b. Graduate study but no graduate degree
 - c. Master's degree
 - d. Doctorate degree (PhD, MD, LLB, EdD, etc.)
181. Is the person who prepares your OER military or civilian?
- a. Military
 - b. Civilian

Appendix B

Authorization to Reproduce the Minnesota
Satisfaction Questionnaire



UNIVERSITY OF MINNESOTA
TWIN CITIES

Vocational Psychology Research
Department of Psychology
Elliott Hall
75 East River Road
Minneapolis, Minnesota 55455

April 26, 1979

AFIT/ENS
Attn. Lt. Col. Dunne
Building 640
Area B
Wright-Patterson AFB, OH 45433

Dear Col. Dunne:

You have permission to reproduce six-hundred (600) copies of the Minnesota Satisfaction Questionnaire (1967 long form) as per requested in my earlier conversations with members of your staff. As I indicated at that time, royalty fees are 13¢ per copy, or \$78 for 600, and these are to be paid as per your purchase order # F33600-79-M-4905.

If I may be of further assistance to your project staff in providing information about the MSQ, scoring, etc. I hope that you will not hesitate to contact me. Upon completion of your study, we would appreciate receiving a copy of the project report for our records.

I send you our best wishes for a successful study.

Sincerely,

George A. Henly
George A. Henly,
Administrative Assistant



UNIVERSITY OF MINNESOTA
TWIN CITIES

Vocational Psychology Research
Department of Psychology
Elliott Hall
75 East River Road
Minneapolis, Minnesota 55455

August 16, 1979

Edward J. Dunne, Jr., Lt. Col. USAF
Department of Operational Sciences
School of Engineering
Air Force Institute of Technology
Wright-Patterson Air Force Base, Ohio 45433

Dear Col. Dunne:

By this letter we authorize the inclusion of the Minnesota Satisfaction Questionnaire in the theses of your two students. We are aware that single copies of the MSQ may be reproduced in the context of reproduction of the theses as a whole, and we authorize reproduction of single copies of the MSQ in such a context.

I look forward to receiving copies of the theses which you have kindly offered to provide. I hope that you and your students have found the MSQ a valuable instrument in this research.

Sincerely,

George A. Henly
George A. Henly,
Administrative Assistant

Appendix C

Factor Structures and Reliability
Coefficients for MSQ and Hoppock Scales

Table C-I

Factor Structures and Reliability
Coefficients for MSQ and Hoppock Scales

Scale Dimension	Eigen Value Structure	% of Var.	MSQ or Hoppock Item	Factor Loading on 1st Factor	Coefficient Alpha
Social Service	4.249	85.0	Q13	.858	0.955
	.347	6.9	Q33	.938	
	.183	3.7	Q53	.956	
	.148	3.0	Q73	.934	
	.073	1.5	Q93	.921	
Creativity	4.165	83.3	Q14	.901	0.949
	.290	5.8	Q34	.926	
	.259	5.2	Q54	.892	
	.169	3.4	Q74	.899	
	.117	2.3	Q94	.945	
Moral Values	3.324	66.5	Q15	.739	0.871
	.631	12.6	Q35	.834	
	.468	9.4	Q55	.890	
	.343	6.9	Q75	.786	
	.234	4.7	Q95	.820	
Independence	3.856	77.1	Q16	.851	0.924
	.388	7.8	Q36	.896	
	.318	6.4	Q56	.888	
	.244	4.9	Q76	.892	
	.194	3.9	Q96	.864	
Variety	3.783	75.7	Q17	.870	0.919
	.495	9.9	Q37	.892	
	.299	6.0	Q57	.764	
	.244	4.9	Q77	.891	
	.179	3.6	Q97	.924	
Authority	3.744	74.9	Q18	.788	0.911
	.473	9.5	Q38	.837	
	.372	7.4	Q58	.870	
	.267	5.3	Q78	.904	
	.145	2.9	Q98	.920	
Ability Utilization	4.324	86.5	Q19	.895	0.961
	.251	5.0	Q39	.923	
	.174	3.5	Q59	.948	
	.128	2.6	Q79	.939	
	.123	2.5	Q99	.944	

Table C-I (Continued)

Factor Structures and Reliability
Coefficients for MSQ and Hoppock Scales

Scale Dimension	Eigen Value Structure	% of Var.	MSQ or Hoppock Item	Factor Loading on 1st Factor	Coefficient Alpha
Social Status	3.466	69.3	Q20	.862	0.887
	.745	14.9	Q40	.893	
	.327	6.5	Q60	.674	
	.278	5.6	Q80	.838	
	.184	3.7	Q100	.878	
Air Force Policies	3.225	64.5	Q21	.827	0.858
	.790	15.8	Q41	.849	
	.440	8.8	Q61	.614	
	.306	6.1	Q81	.871	
	.239	4.8	Q101	.828	
Supervision-Human Relations	3.855	77.1	Q22	.801	0.923
	.464	9.3	Q42	.898	
	.325	6.5	Q62	.853	
	.223	4.5	Q82	.905	
	.132	2.6	Q102	.928	
Security	3.290	65.8	Q23	.866	0.861
	.761	15.2	Q43	.878	
	.450	9.0	Q63	.871	
	.267	5.3	Q83	.830	
	.232	4.6	Q103	.566	
Compensation	4.172	83.4	Q24	.908	0.950
	.280	5.6	Q44	.884	
	.218	4.4	Q64	.934	
	.188	3.8	Q84	.907	
	.141	2.8	Q104	.934	
Physical Working Conditions	4.369	87.4	Q25	.889	0.964
	.270	5.4	Q45	.933	
	.163	3.3	Q65	.942	
	.100	2.0	Q85	.949	
	.096	2.0	Q105	.960	
Advancement Opportunities	3.894	77.9	Q26	.862	0.928
	.509	10.2	Q46	.896	
	.275	5.5	Q66	.792	
	.198	4.0	Q86	.933	
	.125	2.5	Q106	.922	

Table C-I (Continued)

Factor Structures and Reliability
Coefficients for MSQ and Hoppock Scales

Scale Dimension	Eigen Value Structure	% of Var.	MSQ or Hoppock Item	Factor Loading on 1st Factor	Coefficient Alpha
Supervision- Technical	3.706	74.1	Q27	.778	0.912
	.515	10.3	Q47	.891	
	.308	6.2	Q67	.836	
	.265	5.3	Q87	.901	
	.206	4.1	Q107	.893	
Co-Workers	3.524	70.5	Q28	.712	0.887
	.624	12.5	Q48	.765	
	.446	8.9	Q68	.915	
	.229	4.6	Q88	.893	
	.177	3.5	Q108	.893	
Responsibility	3.361	67.2	Q29	.811	0.876
	.698	14.0	Q49	.894	
	.382	7.6	Q69	.652	
	.332	6.6	Q89	.871	
	.228	4.6	Q109	.849	
Recognition	4.286	85.7	Q30	.912	0.958
	.246	4.9	Q50	.910	
	.215	4.3	Q70	.933	
	.149	3.0	Q90	.925	
	.104	2.1	Q110	.949	
Feeling of Achievement	3.815	76.3	Q31	.814	0.921
	.446	8.9	Q51	.889	
	.296	5.9	Q71	.878	
	.259	5.2	Q91	.859	
	.184	3.7	Q111	.924	
Activity	4.275	85.5	Q32	.914	0.957
	.258	5.2	Q52	.932	
	.198	4.0	Q72	.943	
	.148	3.0	Q92	.892	
	.122	2.4	Q112	.941	
Hoppock	3.097	77.4	Q169	.891	0.844
	.415	10.4	Q170	.922	
	.322	8.1	Q171	.829	
	.166	4.1	Q172	.876	

Appendix D

Demographic Distributions of the Sample

Table D-I

Age of the Respondents

Age	Absolute Frequency	Relative Frequency (percent)
25 - 26	15	5.6
27 - 28	61	22.8
29 - 30	47	17.6
31 - 32	35	13.1
33 - 34	29	10.9
35 - 36	48	18.0
37 - 38	13	4.9
39 - 40	16	6.1
missing	3	1.1

Table D-II

Sex of the Respondents

Sex	Absolute Frequency	Relative Frequency (percent)
Male	250	93.6
Female	13	4.9
missing	4	1.5

Table D-III

Marital Status of the Respondents

Category	Absolute Frequency	Relative Frequency (percent)
Married	221	82.8
Never Married	32	12.0
Divorced	9	3.4
Legally Separated	1	0.4
missing	4	1.5

Table D-IV

Rank of the Respondents

Rank	Absolute Frequency	Relative Frequency (percent)
First Lieutenant	7	2.6
Captain	176	65.9
Major	79	29.6
Lieutenant Colonel	1	0.4
missing	4	1.5

Table D-V

Length of Military Service of the Respondents

Number Years Military Service	Absolute Frequency	Relative Frequency (percent)
2 through 4	33	12.5
5 through 7	97	36.9
8 through 10	34	12.7
11 through 13	61	22.8
14 through 16	21	7.9
17 through 19	17	6.4
missing	4	1.5

Table D-VI

Aeronautical Ratings of Respondents

Aeronautical Rating	Absolute Frequency	Relative Frequency (percent)
Pilot, primary flying	42	15.7
Pilot, primary nonflying	15	5.6
Navigator, primary flying	45	16.9
Navigator, primary nonflying	10	3.7
Non-rated	150	56.2
missing	5	1.9

Table D-VII
Job Level of Respondents

Job Level	Absolute Frequency	Relative Frequency (percent)
Squadron	144	42.7
Wing	67	25.1
MAJCOM	37	13.9
Air Staff	7	2.6
JCS or other National Agency	3	1.1
Separate Operating Agency	11	4.1
DOD	3	1.1
other	21	7.9
missing	4	1.5

Table D-VIII
Education Level of Respondents

Education Level	Absolute Frequency	Relative Frequency (percent)
Bachelor's Degree	65	24.3
Some Graduate Study	64	24.0
Master's Degree	126	47.2
Doctor's Degree	7	2.6
missing	5	1.9

Appendix E

Tabulated Data Analysis Results

Table E-I

T-test Comparing Satisfaction Factors of Pilots and Navigators

Satisfaction Factor	Pilots (N=56)	Navigators (N=51)	T Value	Significance (two-tailed test)
	\bar{X}	\bar{X}		
Ability Utilization	15.9	15.2	.74	.460
Achievement	16.5	17.1	-.67	.505
Activity	16.1	16.6	-.56*	.576*
Advancement	13.9	12.1	2.12	.035
A F Policies and Practices	11.4	11.5	-.06	.948
Authority	15.9	14.7	1.54	.124
Compensation	10.5	12.8	-2.56	.011
Co-workers	17.6	17.2	.57*	.569*
Creativity	15.1	15.4	-.32	.749
Independence	14.8	15.2	-.61	.540
Moral Values	17.2	17.2	.00	.998
Physical Working Conditions	13.4	14.4	-1.18	.239
Recognition	14.8	15.0	-.19	.850
Responsibility	15.9	15.5	.48	.634
Security	14.3	12.5	2.35	.019
Social Service	16.1	16.0	.08	.936
Social Status	14.3	13.7	.79	.431
Supervision-Human Relations	15.6	14.9	.78*	.434*
Supervision-Technical	15.4	15.2	.19*	.850*
Variety	15.6	15.2	.51	.611
Overall Satisfaction	19.3	18.9	.52	.605

*Subgroup variances are significantly different. These values are approximated by using separate variance estimates.

Table E-II

T-tests Comparing Satisfaction Factors of Pilots and Non-rated Officers

Satisfaction Factor	Pilots (N=56)	Non-rated Officers (N=144)	T Value	Significance (two-tailed test)
	\bar{X}	\bar{X}		
Ability Utilization	15.9	17.7	-2.11	.036
Achievement	16.5	18.6	-2.97	.003
Activity	16.1	18.2	-2.85*	.005*
Advancement	13.9	14.5	-.95	.342
A F Policies and Practices	11.4	12.6	-2.39	.018
Authority	15.9	17.0	-1.71	.088
Compensation	10.5	12.4	-2.58	.011
Co-workers	17.6	17.7	-.14*	.892*
Creativity	15.1	17.7	-3.39	.001
Independence	14.8	17.0	-3.91	.000
Moral Values	17.2	18.8	-2.65	.009
Physical Working Conditions	13.4	13.7	-.485	.628
Recognition	14.8	16.3	-1.90	.059
Responsibility	15.9	18.2	-3.63	.000
Security	14.3	15.4	-1.87	.063
Social Service	16.1	17.1	-2.26	.025
Social Status	14.3	15.3	-1.65	.100
Supervision- Human Relations	15.6	16.0	-.47*	.638*
Supervision- Technical	15.4	15.7	-.50*	.619*
Variety	15.6	17.4	-2.43	.016
Overall Satisfaction	19.3	20.1	-1.17	.244

*Subgroup variances are significantly different. These values are approximated by using separate variance estimates.

Table E-III

T-tests Comparing Satisfaction Factors of Navigators and
Non-rated Officers

Satisfaction Factor	Navigators (N=51)	Non-rated Officers (N=144)	T Value	Significance (two-tailed test)
	\bar{X}	\bar{X}		
Ability Utilization	15.2	17.7	-2.92	.004
Achievement	17.1	18.6	-2.08	.039
Activity	16.6	18.2	-2.09*	.037*
Advancement	12.1	14.5	-3.44	.001
A F Policies and Practices	11.5	12.6	-2.23	.026
Authority	14.7	17.0	-3.48	.001
Compensation	12.8	12.4	.55	.585
Co-workers	17.2	17.7	-.81*	.420*
Creativity	15.4	17.7	-2.89	.004
Independence	15.2	17.0	-3.05	.003
Moral Values	17.2	18.8	-2.57	.011
Physical Working Conditions	14.4	13.7	.93	.352
Recognition	15.0	16.3	-1.61	.110
Responsibility	15.5	18.2	-4.07	.000
Security	12.5	15.4	-4.60	.000
Social Service	16.0	17.7	-2.28	.023
Social Status	13.7	15.3	-2.53	.012
Supervision- Human Relations	14.9	16.0	-1.39*	.167*
Supervision- Technical	15.2	15.7	-.71*	.481*
Variety	15.2	17.4	-2.95	.003
Overall Satisfaction	18.9	20.1	-1.79	.074

*Subgroup variances are significantly different. These values are approximated by using separate variance estimates.

Table E-IV

Clustering Summary: Objective Outcome Strengths

Iteration Number	Cluster Merged	Cluster Merged	Average Similarity*
1	Feeling of Achievement	Ability Utilization	.565
2	Variety	Creativity	.515
3	Advancement Opportunities	Social Status	.506
4	Social Status	Ability Utilization	.478
5	Activity	Creativity	.413
6	Ability Utilization	Authority	.394
7	Authority	Creativity	.358
8	Recognition	Creativity	.300
9	Creativity	Social Service	.269
10	Independence	Social Service	.227
11	Moral Values	Social Service	.135

*This column contains the average of all pairwise similarities (zero-order correlation coefficients) between objects in the two clusters which were merged.

Table E-V

Clustering Summary: MSQ Facet Satisfaction

Iteration Number	Cluster Merged	Cluster Merged	Average Similarity*
1	Supervision- Technical	Supervision- Human Relations	.878
2	Responsibility	Creativity	.851
3	Achievement	Ability Utilization	.839
4	Variety	Creativity	.817
5	Ability Utilization	Creativity	.788
6	Activity	Creativity	.723
7	Advancement	Social Status	.659
8	Authority	Social Service	.625
9	Recognition	Creativity	.624
10	Social Status	Creativity	.601
11	Creativity	Social Service	.567
12	Security	A F Policies and Practices	.525
13	Independence	Social Service	.501
14	Co-workers	Supervision- Human Relations	.465
15	A F Policies and Practices	Social Service	.450
16	Moral Values	Social Service	.423
17	Supervision- Human Relations	Social Service	.381
18	Physical Working Conditions	Social Service	.282
19	Compensation	Social Service	.223

*This column contains the average of all pairwise similarities (zero-order correlation coefficients) between objects in the two clusters which were merged.

Vita

Terry Ray Talbot was born on 4 January 1948 in Jonesboro, Arkansas. He graduated from high school in Memphis, Tennessee in 1965. In 1969 he received a Bachelor of Science in Aerospace Engineering from the University of Tennessee. Upon graduation, he received an Air Force commission through ROTC.

Captain Talbot's military assignments include pilot training at Williams Air Force Base, Arizona, and operationally flying the C-130 in several different missions. He has been a pilot, instructor pilot, and flight examiner in tactical airlift (C-130E at Little Rock Air Force Base, Arkansas) gunships (AC-130A at Korat Royal Thai Air Base, Thailand) and drone launch and control (DC-130A and E at Davis-Monthan Air Force Base, Arizona).

He is married to the former Bettie Lynn Smith. They have one daughter, Shelly, born on 2 May 1971.

Permanent address: 4840 Rolling Meadows Drive
Memphis, Tennessee 38128