

AD-A077 034

ABCOR INC WILMINGTON MA WALDEN DIV

F/G 6/18

RESEARCH ON PERSONAL DOSIMETERS TO MEASURE HYDRAZINE FUELS IN A--ETC(U)

OCT 79 R ELLERSICK

F33615-77-C-0618

UNCLASSIFIED

SAM-TR-79-22

NL

| OF |
AD A
077034



ADA 077034

REPRODUCED BY
NATIONAL TECHNICAL
INFORMATION SERVICE
U.S. DEPARTMENT OF COMMERCE
SPRINGFIELD, VA. 22161

UNCLASSIFIED

SECURITY CLASSIFICATION OF THIS PAGE (When Data Entered)

11 REPORT DOCUMENTATION PAGE		READ INSTRUCTIONS BEFORE COMPLETING FORM
1. REPORT NUMBER SAM-TR-79-22	2. GOVT ACCESSION NO.	3. RECIPIENT'S CATALOG NUMBER
4. TITLE (and Subtitle) RESEARCH ON PERSONAL DOSIMETERS TO MEASURE HYDRAZINE FUELS IN AIR	5. TYPE OF REPORT & PERIOD COVERED Final Report August 1977 - December 1978	
7. AUTHOR(s) Rosemary Ellersick	8. CONTRACT OR GRANT NUMBER(s) F33615-77-C-0618	
9. PERFORMING ORGANIZATION NAME AND ADDRESS Walden Division of Abcor, Inc. 850 Main Street Wilmington, Massachusetts 01887	10. PROGRAM ELEMENT, PROJECT, TASK AREA & WORK UNIT NUMBERS 62202F 7930-11-40	
11. CONTROLLING OFFICE NAME AND ADDRESS USAF School of Aerospace Medicine (VNL) Aerospace Medical Division (AFSC) Brooks Air Force Base, Texas 78235	12. REPORT DATE October 1979	
14. MONITORING AGENCY NAME & ADDRESS (if different from Controlling Office)	13. NUMBER OF PAGES 58	
	15. SECURITY CLASS. (of this report) Unclassified	
	15a. DECLASSIFICATION/DOWNGRADING SCHEDULE	
16. DISTRIBUTION STATEMENT (of this Report) Approved for public release; distribution unlimited.		
17. DISTRIBUTION STATEMENT (of the abstract entered in Block 20, if different from Report)		
18. SUPPLEMENTARY NOTES		
19. KEY WORDS (Continue on reverse side if necessary and identify by block number) Passive dosimeter Hydrazine Unsymmetrical dimethylhydrazine UDMH		
20. ABSTRACT (Continue on reverse side if necessary and identify by block number) The wide use of toxic and highly reactive hydrazine and unsymmetrical dimethylhydrazine (UDMH) as rocket motor fuels created a need to monitor their vapors in air at concentrations as low as 0.1 ppm. The objective of this research effort was to develop, test, and deliver prototype models of a hydrazine fuels dosimeter capable of filling the personal-exposure monitoring part of this need. This report describes the building and testing of a hydrazine dosimeter.		

DD FORM 1473 EDITION OF 1 NOV 65 IS OBSOLETE

UNCLASSIFIED
SECURITY CLASSIFICATION OF THIS PAGE (When Data Entered)

UNCLASSIFIED

SECURITY CLASSIFICATION OF THIS PAGE(When Data Entered)

20. ABSTRACT (Continued)

Significant analytical difficulties were encountered and considerable technical effort was spent on analytical method adaptation and evaluation. The most precise hydrazine measurements were made using the para-dimethylaminobenzaldehyde (PDAB) colorimetric analysis; isothermal furaldehyde GC analysis was satisfactory but less precise. UDMH analysis was much more difficult. A tedious adaptation of the TPF colorimetric analysis gave reasonable results, but the temperature-programmed furaldehyde GC analysis was not satisfactory. UDMH analysis/collection was not fully evaluated because of program duration and budget considerations; hydrazine evaluation was extensive.

Laboratory test exposures to low ppm concentrations of hydrazine and UDMH were done with the linearity of the dosimeter's response to 0.1-10-ppm time-weighted average concentrations of hydrazine statistically demonstrated. UDMH analytical problems prevented demonstration of UDMH linearity of response. Upon completion of the technical work, 250 dosimeters and 500 extra collection elements were delivered to the USAF School of Aerospace Medicine.

UNCLASSIFIED

SECURITY CLASSIFICATION OF THIS PAGE(When Data Entered)

CONTENTS

	<u>Page</u>
INTRODUCTION	3
PRINCIPLE OF OPERATION	3
Mass Transfer Considerations	4
Sensitivity to Ambient Conditions	6
Response Time Considerations	7
DOSIMETER COMPONENTS	7
COLLECTION ELEMENT DESIGN	7
SELECTION OF ANALYTICAL METHODS	8
Furaldehyde Gas Chromatographic Method	9
Benzaldehyde Gas Chromatographic Method	11
Hydrazine Colorimetric Method	13
UDMH Colorimetric Method	13
Methods Selected	14
EXPOSURE TEST SYSTEM	14
Diffusion System	14
Dilution System	15
Exposure Chamber	16
Exposure Conditions and Calculations	17
VALIDATION TESTING	17
Dosimeter Results	17
Blank Results	19
Impinger Results	19
CONCLUSIONS AND RECOMMENDATIONS	20
ACKNOWLEDGMENTS	20
REFERENCES	20
FIGURES	
1. Dosimeter components	22
2. Chromatogram of 0.1 ppm UDMH, MMH, and H -- furaldehyde method	23
3. Chromatogram of 0.3 ppm UDMH, MMH, and H -- furaldehyde method	24
4. Chromatogram of 0.5 ppm UDMH, MMH, and H -- furaldehyde method	25
5. Chromatogram of 3 ppm UDMH, MMH, and H -- furaldehyde method	26
6. Chromatogram of 1 ppm UDMH and H -- benzaldehyde method	27
7. Chromatogram of 1 ppm UDMH and H with blank collection element -- benzaldehyde method	28
8. Diffusion system for hydrazines	29
9. Flow schematic of exposure system	30
10. Linearity plot: hydrazine GASBADGE TM dosimeter	31

	<u>Page</u>
TABLES	
1. UDMH- and Hydrazine-Standards Performance--Furaldehyde GC Method	32
2. Diffusion Tube System for Generating Hydrazine Standards	33
3. Experimental Diffusion Rates	34
4. Experimental Diffusion Coefficients of Hydrazines in Air	35
5. Statistical Evaluation of Hydrazine Dosimeter Performance	36
APPENDIX A: ANALYTICAL RESULTS	
<u>Tables</u>	
A-1 - Statistical Exposures at 10 ppm; Hydrazine Analysis of Dosimeters and Impingers Exposed to 10 ppm H and UDMH	38
A-2 - Statistical Exposures at 1 ppm; Hydrazine Analysis of Dosimeters and Impingers Exposed to 1 ppm H	40
A-3 - Statistical Exposures at 0.1 ppm; Hydrazine Analysis of Dosimeters and Impingers Exposed to 0.1 ppm H	42
A-4 - Hydrazine Analysis of Dosimeters Stored after Exposure to 10 ppm H and UDMH	44
A-5 - Benzaldehyde GC Method Evaluation: H Analysis of Dosimeters and Impingers Exposed to 0.25 ppm H and UDMH	45
A-6 - UDMH Analysis of Dosimeters and Impingers Exposed to 10 ppm H and UDMH	47
A-7 - UDMH Analysis of Dosimeters Stored after Exposure to 10 ppm H and UDMH	49
A-8 - Benzaldehyde GC Method Evaluation: UDMH Analysis of Dosimeters and Impingers Exposed to 0.25 ppm H and UDMH	50
A-9 - TPF Colorimetric Method Evaluation: UDMH Analysis of Dosimeters and Impingers Exposed to 0.1 ppm H and UDMH	51
APPENDIX B: CALCULATIONS	
<u>Tables</u>	
B-1 - Collection-Element Capacity for H Adsorption	52
B-2 - Calculation of Diffusion Coefficients	53
B-3 - Exposure Test System Calculations	54
B-4 - Exposure Conditions	56
B-5 - Typical Exposure Test Calculation	57

RESEARCH ON PERSONAL DOSIMETERS TO MEASURE HYDRAZINE FUELS IN AIR

INTRODUCTION

A major use of hydrazine (H) and its derivatives is as a rocket fuel. The hydrazines are strong reducing agents that will burn in air or any other oxygen source, with a considerable evolution of heat and conversion to low-molecular-weight products. When combined with an appropriate oxidizing agent such as liquid oxygen, they give high exhaust velocities and, hence, high specific impulse at relatively low combustion temperatures. The hydrazines, however, do present serious health hazards as toxic chemicals with threshold limit values (TLVs) established at 0.1 ppm for H, 0.2 ppm for monomethylhydrazine (MMH), and 0.5 ppm for unsymmetrical dimethylhydrazine (UDMH). Since H and its methyl derivatives are widely used as rocket engine fuels by the U.S. Air Force, a suitable measuring device, such as a passive dosimeter, is required to record personal exposure.

This report describes the adaptation of the GASBADGETM dosimeter for use as a hydrazine monitor. The GASBADGE dosimeter, illustrated in Figure 1, is a passive sampler, requiring no sampling pump, handling of chemicals, or wearing of a cumbersome apparatus. Based upon a diffusive principle described later, the dosimeter collects a total mass of contaminant which is proportional to exposure time and the average contaminant concentration. Sampling of the gaseous or vapor contaminants of interest is effected by either chemical reaction with, or adsorption onto, a collection element. The collection element is subsequently removed from the dosimeter for chemical analysis, and the time-weighted average (TWA) concentration sampled can be calculated from the analytical results.

The necessary dosimeter adaptation involved designing a collection element that could collect, and later release, hydrazine quantitatively and selecting an analytical method or methods to measure the hydrazines collected.

PRINCIPLE OF OPERATION

A suitable dosimeter must collect a sample of the contaminant proportional to its ambient concentration and be independent of air circulation patterns in the vicinity of the dosimeter. Movement of the

subject wearing the dosimeter should have no effect on observed contaminant concentrations. In the GASBADGE a diffusional resistance within the sampler far exceeds the diffusional resistance of convective mass transfer external to the sampler. Contaminant can be introduced into the dosimeter only by diffusion through an inert porous draft shield. This draft shield provides a stagnant air layer (diffusive barrier) inside the dosimeter which is completely unaffected by external circulatory air patterns. A honeycomb grid provides mechanical support of the draft shield, holds the collection element in place, prevents any convection within the sampler, and defines the diffusion path length.

Mass Transfer Considerations

Internal Mass Transfer Resistance--The dosimeter is designed so that the limiting resistance to mass transfer of contaminant to the collection medium is contained in the stagnant air layer within the dosimeter; i.e., between the draft shield and the active collection element. Fick's First Law of Diffusion (8) describes this diffusive transport process:

$$N = -DA \frac{dc}{dx} \quad (1)$$

where:

- N = diffusive transport rate (moles/sec)
- D = contaminant diffusivity in air (cm²/sec)
- A = diffusion path cross-sectional area (cm²)
- x = distance from front of diffusion layer (cm)
- c = contaminant concentration at x (moles/cm³)

Equation 1 may be integrated over the diffusion layer (of thickness λ) to yield the rate of contaminant collection. The boundary conditions used for concentration are:

- 1) the concentration of contaminant at the surface of the collection element is zero (i.e., complete collection efficiency);
- 2) the concentration of contaminant at the badge face is the ambient concentration C_∞ (i.e., all mass transfer resistance is internal to the dosimeter).

The final result for the rate of contaminant collection is

$$N = \frac{DAC_\infty}{\lambda} \quad (2)$$

For a given exposure time t (in seconds), the total mass of contaminant collected becomes:

$$Nt = \frac{DAC_{\infty}t}{\lambda} \quad (3)$$

which is proportional to the ambient concentration and elapsed time. Chemical analysis of the collection element is used to determine Nt , and C_{∞} may be readily calculated from Equation 3 by substituting the contaminant diffusivity in air and the exposure time. In practice, an empirically determined calibration factor may be necessary to account for the influence of parameters such as the efficiency of the collection medium.

External Mass Transfer Resistance--External convective resistance to mass transfer is difficult to control, so the GASBADGE has been designed to minimize these effects. The following relationship describes convective mass transfer external to the dosimeter for the case of total boundary-layer-dominated transport:

$$N = kAC_{\infty} \quad (4)$$

where:

k = the convective mass transfer coefficient

The mass transfer coefficient can be estimated from the correlation for low Reynolds number drag ($10 < Re < 3000$) given in Knudsen and Katz (6). Using the Chilton-Colburn analogy, which is exact in this case, the mass transfer coefficient is given by:

$$Sh = \frac{kL}{D} = 1.45 (Re_L)^{0.4} (Sc)^{1/3} \quad (5)$$

where:

Sh = the Sherwood number
 Sc = Schmidt number
 Re_L = length Reynolds number

or,

$$k = 1.45 \frac{D}{L} (Re_L)^{0.4} (Sc)^{1/3}$$

To minimize the effect of ambient convection on dosimeter sampling efficiency, the internal diffusive resistance must dominate the external boundary layer resistance.

$$R_{\text{diffusive}} = \lambda/D \quad (6)$$

$$R_{\text{convective}} = 1/k \quad (7)$$

From Equations 5, 6, and 7:

$$\frac{R_{\text{diffusive}}}{R_{\text{convective}}} = k_1 V^{0.4} \quad (8)$$

where:

k_1 = proportionality constant dependent on molecular properties and geometric dimensions

V = face velocity across the dosimeter

As the face velocity is lowered, the external mass transfer resistance will increase. For the dosimeter to accurately sample the pollutant of interest, Equation 8 suggests that a minimum air velocity will be required and that once this minimum is achieved, performance will be velocity insensitive over a wide range. Evaluation of velocity effects both at Walden and at the Research Triangle Institute indicates no significant effect at face velocities as low as 0.27 kph. The face velocities encountered in most work places have a range of 0.91-1.37 kph. Field and laboratory experience to date substantiates the negligible influence of external boundary-layer resistance on the expected results.

Sensitivity to Ambient Conditions

If the limiting resistance to mass transfer is in the diffusive layer, the only transport parameter sensitive to ambient temperature or pressure is contaminant diffusivity, D , which depends on these parameters as:

$$D \propto \frac{T^{3/2}}{P}$$

The ambient concentration expressed in ppmv is a mass/volume relationship also dependent on temperature and pressure:

$$C_{\infty} \propto \frac{P}{T}$$

As noted above, the mass collected by the GASBADGE is proportional to the contaminant diffusivity and the ambient concentration as follows:

$$Nt \propto DC_{\infty}$$

Therefore:

$$Nt \propto \left(\frac{T^{3/2}}{P}\right) \left(\frac{P}{T}\right)$$
$$Nt \propto T^{1/2}$$

Thus, the mass collected by the dosimeter is dependent only on the square root of the absolute temperature. The mass of hydrazine collected at 50°C is only 5% more than the mass collected at 20°C when all other conditions are equal.

Response Time Considerations

A measure of response time is the average residence time of contaminant within the diffusion zone. Assuming 100% collection efficiency, contaminant concentration at the collecting-element surface will be zero. Thus, the average concentration within the diffusion zone is simply $C = C_{\infty}/2$, and the mass collected is $C_{\infty}/2 \cdot \lambda A$. The residence time may be readily calculated, as follows:

$$t_{\text{res}} = \frac{\text{mass collected}}{\text{diffusive transport rate}} = \frac{C_{\infty}/2 \cdot \lambda A}{\frac{DAC_{\infty}}{\lambda}} = \frac{\lambda^2}{2D} \quad (9)$$

For monitoring hydrazine, the residence time is calculated to be 9.4 seconds. This short residence time is sufficient for the dosimeter to sample a true TWA concentration.

DOSIMETER COMPONENTS

Components of the GASBADGE hydrazine dosimeter are shown in Figure 1. The dimensions of the GASBADGE are 6.6 cm L x 5.0 cm W x 1.6 cm D (excluding the spring clip), and its weight is approximately 28 g.

An exposure information label is affixed to the outside of the back cover of the dosimeter. Space is provided for: employee name, date of exposure, duration of exposure, and contaminant of interest. Since the label is removable, it can serve as a positive sample identification throughout the analytical procedure steps.

COLLECTION ELEMENT DESIGN

Since H is a basic substance that reacts with acids to form salts more stable and resistant to oxidation than H itself, an acid-impregnated substrate should be a good collection element for H.

The following substrate materials were immersed in 0.1N H₂SO₄ and evaluated for weight of acid absorbed and ease of handling:

Glass-fiber filter paper - Gelman
Silica gel on plastic mat
Nonwoven polypropylene sheet - Pellon N 1251E
Nonwoven polypropylene sheet - Pellon 2107A
Nonwoven polypropylene sheet - Tyvek 1056D
Nonwoven polypropylene sheet - Tyvek 1042B

The Pellon 2107A and the two Tyveks absorbed minimal amounts of acid and were removed from consideration. The Gelman glass-fiber paper, the silica gel on plastic mat, and the Pellon N 1251E all absorbed significant amounts of acid and were further evaluated with several different concentrations of HCl and H₂SO₄. A glass-microfiber paper (Whatman GF/C) was also included in this latter evaluation.

The glass-fiber and microfiber papers absorbed the largest amounts of acid but tended to break into small fragments during desorption and analytical workup. The silica gel on plastic also absorbed large quantities of acid, but particles of the silica gel coating flaked off with even minimal handling. These three materials were deemed unsuitable for use because of the handling problems. Pellon N 1251E was chosen as the substrate for the collection elements.

Sulfuric acid was selected as the collection medium because it forms stable H salts, is less volatile than HCl, and reacts with dibasic H on a mole/mole basis. A Pellon N 1251E (hereafter called Pellon) coupon impregnated with 5N H₂SO₄ has the capacity to adsorb a TWA concentration of more than 1000 ppm of the hydrazines (Appendix B, Table B-1). This combination was selected as the collection element for the hydrazine dosimeters.

To demonstrate feasibility, 12 dosimeters were exposed to a 10-ppm TWA concentration of H and UDMH. Six dosimeters had glass-fiber draft shields and six had Pellon draft shields; two dosimeters of each type were prepared as blanks.

Hydrazine and UDMH were found on all exposed collection elements and were not found on blank collection elements. No significant difference was found between dosimeters with glass-fiber draft shields and those with Pellon draft shields. Since glass-fiber draft shields have been used successfully in commercial GASBADGE dosimeters for SO₂, NO₂, and organic vapors, they were selected for use in the hydrazine dosimeter.

SELECTION OF ANALYTICAL METHODS

A major objective of this program was to evaluate analytical methods for determining the hydrazines collected by the dosimeter.

Both gas chromatographic (GC) and colorimetric procedures were adapted for use with the GASBADGE; the results of each procedure are given in this section.

Furaldehyde Gas Chromatographic Method

The National Institute for Occupational Safety and Health (NIOSH) analytical procedure for hydrazine compounds in air (1) was used with minor modifications as detailed in the operations manual (2), section 7.A. This NIOSH procedure is based on work by Wood and Anderson (9), and both procedures claim to analyze for H, MMH, UDMH, and phenylhydrazine. We found significant difficulties with this temperature-programmed analysis of furaldehyde derivatives of the hydrazines.

Programmed Analysis for MMH, UDMH, and H--Standard solutions were made up in 0.8N H₂SO₄ so that 2 ml contained MMH, UDMH, and H in amounts equivalent to those collected by a dosimeter at 100% efficiency during a 4-hour exposure to the ambient concentration indicated. The MMH derivative is known to continue reacting with furaldehyde to form a secondary product which does not elute from the GC column (9). To minimize this problem, standards and samples were extracted with ethyl acetate exactly 1 hour after derivatization; MMH was still extremely difficult to quantify.

The MMH derivative peak was hard to detect at the 0.1-ppm level; also, the shape of the peak made quantitative measurements difficult at concentrations below 1 ppm or higher than 3 ppm. Figures 2-5 illustrate these problems, but also show the positive identification of the three hydrazines in the same solution--a significant advantage of this method.

Subsequent work with H and UDMH standards at the 10-ppm level indicated problems in obtaining a standard curve. Triplicate injections of each derivatized standard were made; after discarding obvious outliers*, UDMH derivative peak areas on replicate injections still varied considerably (as shown in Table 1). Hydrazine derivative peak areas were more reproducible, but often a reasonable difference in mean peak areas for different concentrations was not found for one or both of the hydrazines (noted under "Range" in Table 1). When this occurred, the most reasonable value for that day's run (based on our experience) was used with a proportionally calculated value for the other concentration to construct the standard curve and determine the

*Areas differing by more than 3 standard deviations from the mean peak area.

hydrazines collected by the dosimeters analyzed that day. Tables A-1 and A-6 in Appendix A present the results calculated in this way.

It should be noted that these problems occurred in the most ideal case--analysis of standards with no dosimeter collection elements present. No pH variations or interferences were present.

As Table 1 shows, refrigerating the standards between ethyl acetate extraction and analysis improved the precision of UDMH replicate injections. Refrigerated standards of 5 and 10 ppm yielded reasonable differences in peak areas in most cases.

General Problems with the Programmed Analysis--The procedure is lengthy and tedious. Practical considerations require handling a series of samples and standards at the same time, although it is known that H, MMH, and UDMH derivative peak areas change somewhat with time. The MMH derivative secondary product may darken the solution, precipitate, and adsorb some of the H derivative on the precipitate (3). We found a few darkened solutions, but no correlation between analytical results and darkening. Removing the ethyl acetate layer to a clean septum-sealed vial immediately after extraction may help overcome this problem; we did this in our later work.

Each programmed chromatogram required a minimum of 20 minutes. Triplicate injections of two standards consumed 2 hours of GC time; therefore, desorbed dosimeters were analyzed by a single injection because of time constraints. With the known imprecision on standards, a single injection did not seem to be a fair evaluation of dosimeter performance. Results from single injections of dosimeters exposed to 10 ppm of H were included in Table A-1, however, and used to provide a more complete picture of GASBADGE response at different levels (Table 5, Fig. 10).

Isothermal Analysis for Hydrazine Only--Isothermal analysis improved both the precision and the speed of the furaldehyde GC method. Peak areas checked within $\pm 1-7\%$ on replicate injections of both standards and dosimeter samples. Table 1 shows the standard performance with collection elements present. Probably most significant is the fact that since a chromatogram can be run in 6 minutes or less, replicate injections can be made on samples as well as standards in a normal working day.

A measurable H derivative peak occurred in the reagent blank and was somewhat larger when a desorbed blank collection element was analyzed. When this derivative peak area was subtracted from the peak areas of standards, good day-to-day correlation of standard curves for H was obtained. This procedure was used to analyze dosimeters exposed to 1 and 0.1 ppm H; results are given in Tables A-2 and A-3.

Benzaldehyde Gas Chromatographic Method

In a further effort to establish an analytical procedure that could determine both UDMH and H in a single programmed-GC analysis, benzaldehyde was investigated as a derivatizing agent for the hydrazines.

Benzaldehyde is not oxidized as easily as furaldehyde and could be used without distillation. Work done by Gerry Wood at Los Alamos (10, 11) was the basis for our work. The procedure permitted a more positive pH adjustment which would overcome slight variations in pH of desorbed collection elements, but required a much longer derivatization time for UDMH (approximately 12 hours (11)) than did the furaldehyde method.

The procedure developed in our laboratory involved making up standards in 1:1 methanol/1N H₂SO₄. The pH was adjusted to the alkaline side, using 1.2N NaOH. (Blank solutions were adjusted to a phenolphthalein endpoint, and the same volume of NaOH was then added to each standard.) Also, 10 μ l benzaldehyde was added to each standard, and the solutions were mixed and left to derivatize overnight. The next day, 1 ml ethyl acetate was added to each derivatized standard and mixed thoroughly. Finally, 2-5- μ l injections of the ethyl acetate layer were analyzed by GC with a flame ionization detector.

A 1-m x 2-mm-ID silanized glass column was packed with 10% silicone OV-7 on 80/100-mesh Supelcoport. N₂ was used as the carrier gas in the Hewlett Packard 5750 gas chromatograph, and a Perkin-Elmer Model 1 computing integrator was used for peak area data. The same column and chromatograph were used for the earlier furaldehyde GC work. Standards roughly equivalent to the mass collected on a dosimeter during a 4-hour exposure to 0.1, 1, and 10 ppm of H and UDMH (2, 20, and 200 μ g) were derivatized and analyzed.

Hydrazine standards alone were run isothermally at 230°C with good reproducibility and a good linear regression line. The same was true of UDMH standards run isothermally at 160°C. At lower ranges (2-20 μ g/2 ml standard) the UDMH derivative gave two peaks; the first peak was used in calculations and gave good results.

Standards containing both H and UDMH were derivatized and run with temperature programming from 100° to 230°C. Agreement was good between replicate injections, but in one 20- μ g standard (shown as Fig. 6), no H derivative peak showed up on triplicate injections, although the UDMH derivative peak did. The same standards were added to unexposed collection elements, and both H and UDMH derivative peaks showed up in all. Figure 7 shows the same standard as Figure 6, with a collection element. Replicate injections seemed in good agreement, but only a limited number of GC runs were performed.

Dosimeters were exposed to 0.25-ppm levels of H and UDMH for 4 hours on 4 separate days; dosimeters from each day were analyzed by the benzaldehyde GC procedure. Low-level standards (1-10 $\mu\text{g}/2\text{ ml}$) were added to unexposed collection elements to make the standards as similar as possible to desorbed dosimeter elements. Only 1 of the 4 days of analyses produced a reasonable standard curve for H. The UDMH derivative peaks observed during that day's analyses were reproducible but did not correlate with concentration (the 1- μg peak area was much higher than the 2- and 10- μg areas which were about the same). Tables A-5 and A-8 give analytical results for dosimeters analyzed by this procedure.

Some of the difficulties with the benzaldehyde GC analysis were:

- poor reproducibility of standards, especially UDMH.
- peak areas of standards not proportional to concentration, as noted above.
- sometimes no derivative peak for either H or UDMH in a standard containing both. This was not consistent for replicate injections, and was often accompanied by a change in the shape of the peak which did appear.
- variable number of UDMH derivative peaks (1, 2, or 3), even in replicate injections from the same derivatized standard.

Attempts to overcome these problems included:

- removing an aliquot of the desorption solution from the collection element before derivatization.
- refrigerating the derivatized solutions until analyzed.
- isothermal GC runs. This was not successful for UDMH and could not be fully evaluated for H because storage of derivatized samples may have caused problems.

None of these measures appeared likely to solve the analytical problems. Individual pH adjustment of each sample and standard before derivatization might significantly improve the procedure. This was not tried because it would make the analytical method even more tedious and time consuming.

In summary, our initial work with H and UDMH standards with no collection elements present gave reproducible and reasonable results. Results of a more rigorous evaluation of the benzaldehyde derivative method, using unexposed collection elements plus standards at low levels, showed the problems cited previously. This method was considered not suitable for evaluating the hydrazine dosimeters.

Hydrazine Colorimetric Method

The NIOSH method (2) using PDAB as a colorimetric reagent was adapted for use at low levels (1-20 μg) by omitting the dilution with glacial acetic acid and reading absorbance in 1" test tubes. Reference 5: section 7B gives our detailed procedure.

Good standard curves were obtained, and there was no pH problem with desorbed dosimeters. This procedure was used to analyze dosimeters exposed to 1- and 0.1-ppm hydrazine levels; the results are given in Tables A-2 and A-3.

UDMH Colorimetric Method

The TPF (trisodium pentacyanoamino ferrate) colorimetric procedure (4) used by the Aerospace Medical Research Laboratories was adapted to analyze desorbed dosimeters for UDMH at 0.25- and 0.1-ppm levels. Our work showed pH to be an important factor. The analysis solution must be within pH 3-5.4 for the citric acid buffer to be effective in keeping the pH at 5.4. Since the dosimeter collection elements varied slightly in the amount of H_2SO_4 absorbed, the pH of each desorbed solution had to be adjusted individually to work at these low levels. This proved to be tedious, but successful in the 1-10- μg range (\approx 0.05-0.5 ppm).

The procedure developed in our laboratory included desorbing an unexposed collection element plus standard (or an exposed dosimeter collection element) in a test tube containing 2 ml of distilled water. Small amounts of 5N, 1.2N, and 0.5N NaOH were added until pH 3 was reached; a microelectrode was used to monitor the solution pH. The different-normality NaOH solutions were needed to keep the volume low and to avoid overshooting the desired pH range. Each solution volume was made up to 13 ml with pH 5.4 buffer, 1 ml TPF reagent was added, and the resulting solution was mixed. After 20 minutes, absorbance was read against a blank at 480 nm. Standard curves varied from day to day and the need for individual pH adjustment made the analysis procedure lengthy, but it seemed possible to analyze dosimeters for UDMH at the 0.1-ppm level following this procedure.

Using the TPF method, one group of 5 dosimeters exposed to 0.1-ppm UDMH was analyzed with good results (Table A-9). Attempts to shorten the procedure by using collection elements impregnated with 1N H_2SO_4 , rather than the usual 5N H_2SO_4 , or by omitting the citric acid buffer were unsuccessful. We had hoped that each of these steps would make the pH adjustment less tedious. This was not the case, and the analytical results were unreasonably high in both cases.

Methods Selected

After evaluation of these various methods, the furaldehyde isothermal GC procedure and the hydrazine (PDAB) colorimetric method were selected to analyze dosimeters exposed to H only. One half of each day's exposure set would be analyzed by each method.

EXPOSURE TEST SYSTEM

The experimental equipment to test the performance of the hydrazine dosimeters consisted of a diffusion system to dynamically generate low ppm levels of the hydrazines, a dilution system to adjust the diffused concentration to exact levels of interest, and an exposure chamber.

Diffusion System

Known concentrations of the hydrazines were generated in the diffusion system shown in Figure 8. A low flow of tank N₂ was passed through 25-mm-diameter Pyrex tubing that was filled with glass beads and submerged in a water bath. The beads aided in heat transfer, bringing the N₂ to the bath (diffusion) temperature before it passed over the diffusion tubes.

The tubes were placed inside a 50-mm-diameter Pyrex joint with an O-ring seal clamped with a spring-closed pinch clamp and were submerged in the water bath. The system was one glass-blown unit, with the N₂ inlet and outlet above water to avoid underwater connections and possible leaks. The entire unit could be lifted out of the water before the clamp was opened to remove the diffusion tubes.

Six diffusion tubes varying in bore diameter from 0.5 to 5 mm were purchased from AID Inc., Avondale, Pa., and were calibrated and used at the bore lengths shown in Table 2. A National Appliance Company Model 220 water bath (interior dimensions--31 cm L x 33 cm W x 18 cm D) maintained a constant temperature within $\pm 0.3^\circ\text{C}$ in the 30-40°C range and within $\pm 0.5^\circ\text{C}$ at the 50°C range. (Run 5 at the 10-ppm level had significantly more variation, ranging from 50.0° to 51.5°C.)

Bath temperatures were recorded daily, and the mean temperature for the run was used in determining diffusivity. Runs were long enough to generate a significant weight loss, well within the accuracy of the Sartorius Model 2472 analytical balance used. The tubes were allowed to come to temperature equilibrium in the diffusion system, then were

taken out and cooled \approx 15 minutes at room temperature (to avoid thermal problems with the balance), weighed in a wire basket, and returned to the bath. The same procedure was followed at the end of the run; the diffusion time was the time a tube was removed from the bath for final weighing less the time it was returned to the bath after initial weighing.

The system functioned very well at all levels throughout the program. Table 3 gives the diffusion rates for all determinations, and Table 4 lists the diffusion coefficients calculated from the experimental data. Table B-2 gives the equations used for calculating both experimental and theoretical diffusion coefficients.

The experimental diffusion coefficient (D_0) was used to determine the mass collected by the dosimeter in test exposures. The experimental D_0 value was corrected for the actual exposure-chamber temperature and pressure to give the diffusivity at sampling conditions. Tables B-3 and B-5 show the calculations.

Dilution System

The dilution system is shown in Figure 9 as part of the exposure system. A low flow (\approx 0.1 lpm) of tank N_2 was continually passed over the diffusion tubes and directed by means of a 2-way valve either to exhaust or to the exposure chamber. Another 2-way valve permitted entry of dilution air which mixed with the diffusing hydrazines before their entry into the exposure chamber. The total dilution flow included the N_2 and the "wet" and "dry" air flows--measured by Fischer and Porter (Model 10A 1300 series) rotameters calibrated against a wet test meter.

The exposure chamber was located on a bench top \approx 60 cm directly above the diffusion system, with the dilution air flow coming in at right angles to the diffusion flow and midway between the diffusion tubes and the exposure chamber. Only glass or Teflon tubing was used in contact with the hydrazines. The 2-way valves were 3-way glass stopcocks with Teflon plugs connected into the system with Teflon tubing.

Room air pumped through activated silica gel and charcoal to remove moisture and organics was used for dilution. The air stream was split into two parts to permit humidity control, and its volume was monitored by "wet" and "dry" rotameters. The wet air was passed through one or two 500-ml impingers filled \approx 2/3 full with distilled water. The resultant humidity of the total dilution flow was measured by wet and dry bulb thermometers placed in the exposure chamber for 30 minutes or more after each dosimeter exposure set.

Exposure Chamber

The exposure chamber (shown in Fig. 9) consisted of a 21-liter cylindrical polycarbonate chamber (30 cm high x 30 cm diameter, internal dimensions) with a removable cover and a wire rack for affixing dosimeters around the chamber perimeter. A thermometer and the fan motor shaft were inserted through holes in the cover, and a third port was connected directly to the exhaust system.

Three holes equally spaced around the chamber perimeter permitted insertion of midget impingers at the same level as the dosimeters. Rubber stoppers on the extended glass-impinger tubing sealed these chamber openings. H-contaminated air was pulled through the impingers at a rate of 1 liter/min using a critical-orifice-controlled pump. The orifices were calibrated with a bubble meter before and after each exposure run, and the average value was used in calculations.

A 10-cm-diameter squirrel-cage blower with a single-speed motor was used to provide uniform air movement of the chamber volume. All dosimeters were exposed to the same face velocity created by the blower. An Alnor Model 6000 velometer with a low-flow probe indicated that the velocity was in the range of 0.5 kph. The size of the probe and the range of the instrument, however, did not seem appropriate for an accurate measurement.

After the test exposure series were completed, a Baratron capacitance manometer gave readings equal to 0.2 and 0.5 kph for different placements of the pitot tube. The 0.5-kph placement was most like the dosimeter's positioning but somewhat closer to the blower. The geometry of the tube did not allow its placement in the exact position occupied by the dosimeters.

Dilution air flows, pumps, and exhaust system were not in full operation when either instrument measurement was made, and the system had to be dismantled and moved before this could be corrected. As noted earlier the dosimeter is relatively insensitive to the face velocity. It has performed well at ≈ 0.27 kph in tests at Walden and at Research Triangle Institute. We feel that with our exposure system in full operation, the face velocity was above the 0.27 kph value.

Three chamber volumes were required to purge the chamber (remove 95% of the former concentration) (7). At 10 liters/min it would take more than 6 minutes, and at 5 liters/min more than 12 minutes, to change 95% of the 21-liter chamber volume. Our standard practice was to put the test dosimeters in the chamber; turn on dilution flows, pumps, and the exhaust system; direct the diffusing hydrazines into the dilution flow; and allow 12 minutes for equilibration.

The exposure was timed for 12 minutes after entry of the hydrazines into the chamber. Four hours later the hydrazine flow was diverted to exhaust and the exposure completed. However, the dosimeters and impingers were left in place 24 more minutes to provide an extra measure of protection for the lab staff.

Exposure Conditions and Calculations

Table B-3 shows the general calculation of the concentration of hydrazine delivered to the exposure chamber by the diffusion and dilution system. Also shown is the calculation of the mass collected by the impingers and dosimeters at 100% collection efficiency.

When several exposure sets were planned, these exposures were all performed within the same diffusion run. This provided the same diffusion rate and D_0 for the series of exposures, but the daily conditions of temperature, pressure, orifice, and dilution flows were used in calculating delivered concentrations for each individual exposure set.

Table B-4 gives the data recorded for an actual exposure on October 4, 1978, and Table B-5 uses the data to calculate the delivered concentration and expected mass collected by the dosimeter.

Conditions shown in Table B-4 are typical of those for all exposures performed. For the 9 exposure days listed in Table 5 and used for statistical evaluation, the mean relative humidity was $57 \pm 5\%$, the mean atmospheric pressure was 764 ± 6 mmHg, and the mean average temperature during the 4-hour run was $22.9 \pm 1.6^\circ\text{C}$.

All analytical results and their statistical evaluation are presented in μg ; the corresponding ppm level is indicated in the tables.

VALIDATION TESTING

Dosimeters and impingers were exposed to UDMH and H at 10-, 0.25-, and 0.1-ppm levels and to H alone at 1-ppm levels.

Dosimeter Results

Appendix A gives the analysis results for all exposures conducted in the program, and the table titles indicate the principal purpose of the analytical series. Tables A-1 to A-5 list H results and Tables A-6 to A-9 list UDMH results.

Statistical Evaluation--Table 5 shows the dosimeters' mean response to 10-, 1-, and 0.1-ppm levels of H as determined by GC and colorimetric analysis. Ten dosimeters were exposed on each of the three exposure dates--30 at each ppm level. Figure 10 is a plot of the dosimeter response versus delivered concentration for the GC analysis data. Individual data for the three exposure sets at 0.1 ppm could not be shown on the graph but are listed in Table 5 and included in the linear regression calculation. The linear regression line for these data points has a correlation coefficient of 0.995; the equation for the line is:

$$y = 0.91X - 0.26$$

As the plot and the correlation coefficient show, there is linear response of the dosimeter to the concentration delivered in the range from 0.1 to 10 ppm. This is particularly impressive because results from programmed GC analysis at 10 ppm were combined with isothermal GC analytical results at 1 and 0.1 ppm. This was the only set of analysis data available for all three concentrations. As Table 5 shows, significantly better precision could be expected if the PDAB colorimetric procedure for H were used to evaluate dosimeter performance.

Stability of Exposed Dosimeter Samples--As shown in Tables A-1 and A-6, half of each day's 10-ppm H and UDMH exposure set was analyzed the next day; the other half was stored under refrigeration until analysis. Due to the requirements of the programmed GC method, the most immediate analysis time was the day after exposure; the second half of each set was analyzed 3, 4, and 7 days after exposure. A t-test analysis for difference between the first and the second half showed no significant difference between the halves, indicating that an exposed dosimeter sample was stable for at least 7 days.

Six dosimeters exposed to 10-ppm H and UDMH were stored under refrigeration \approx 5 weeks before programmed GC analysis. Table A-4 shows the H analysis results which averaged 150% of the expected value. Table A-7 gives both programmed GC results and TPF colorimetric results for UDMH. The GC results were high, averaging 134%, but the colorimetric results averaged 81% of the expected value. Storing an exposed dosimeter (or its collection element) for a month or more without loss of sample may be possible.

Test exposure sets at 1 and 0.1 ppm were stored for \approx 3 days before colorimetric analysis and \approx 6 days before isothermal GC analysis. Statistical testing for difference was not performed on these data, but no storage losses are suspected.

Exposure Time Dependence--The three exposure tests at the 0.1-ppm level employed 0.14-ppm concentrations delivered to the exposure chamber for 3 hours. As Figure 10 and the linear regression line show, these correlated extremely well with 4-hour exposures to 1- and 10-ppm levels.

Blank Results

Unexposed collection elements were included whenever exposed collection elements were analyzed. In the programmed furaldehyde GC analysis, no H or UDMH was found. Even more significant is the fact that a covered dosimeter exposed to 10 ppm H and UDMH for 4 hours (#34, 4/18/78 exposure) showed no H or UDMH collected, thereby demonstrating the effectiveness of the cover. Tables A-1 and A-6 show these results.

Blank collection elements did show a H peak in isothermal GC analysis at 1- and 0.1-ppm levels. Earlier work indicated this was principally a furaldehyde reagent blank, and the peak showed up even when no blank collection element was present. The peak area was somewhat larger when a blank collection element was present--perhaps due to pH effects--and varied from day to day with the batch of furaldehyde reagent used. Unexposed collection elements were added to all standards used, and the peak area for the blank was used as a zero concentration value in calculating analytical results. Therefore, no blank results are reported at these concentration levels.

Impinger Results

At the 10-ppm level, impingers were filled with 10 ml 0.8N H₂SO₄ to simulate the acidity of the dosimeter collection elements and were analyzed by programmed furaldehyde GC. Only 7-33% of the expected H was found; UDMH results were ≈40% of the expected value (Tables A-1, A-6). Also, the flow rate was changing, probably due to clogging of the critical orifices.

Glass-fiber filters were inserted in front of the orifices, and the orifices were calibrated before and after each 1- and 0.1-ppm exposure. As for the NIOSH colorimetric procedure, 10 ml 0.1M HCl was used as the absorbing solution for H. Table A-2 shows precise colorimetric results obtained for H, with ≈60% recovery at the 1-ppm level; dosimeter recovery at this level averaged 74%. Unfortunately, impinger results at the 0.1-ppm level were not too reliable. The reported results (Table A-3) are from the analysis of small (≈0.5 ml) aliquots of impinger solutions stored for a few days after improper standard makeup invalidated the original analysis results.

The impinger results did not provide the needed verification of actual H concentration delivered to the exposure chamber. Had more time remained after final analysis-method selection, this problem would probably have been solved.

CONCLUSIONS AND RECOMMENDATIONS

The GASBADGE hydrazine dosimeter containing the collection element described herein is an effective personal sampler for hydrazine fuels. Its linear response to delivered H concentrations from 0.1 to 10 ppm has been statistically demonstrated in this program.

UDMH was also collected by the dosimeter at these levels, but analytical problems prevented accurate evaluation of the dosimeter's UDMH performance. Colorimetric data showed good UDMH recovery; GC analysis results were too imprecise to be of value.

More precise and accurate methods need to be developed for analyzing exposed dosimeters. The effect of acidity on the stability of UDMH standards and on the derivatizing techniques for GC analysis should be further studied. The use of a concentrator before the GC column should be investigated.

The hydrazine dosimeter should be tested at varying levels of temperature, humidity, and face velocity to more completely characterize its performance. Also, the effect of interferences and the effects produced by the presence of several hydrazines when one or all are being monitored warrant study.

ACKNOWLEDGMENTS

The author wishes to acknowledge the contribution of Theresa Kotlar of Walden who performed the experimental work for this program, and of Dr. Gerry Wood of Los Alamos Scientific Laboratory who provided background information on his GC derivatization work.

Technical guidance during the program was provided by Dr. Leonard Luskus, Project Scientist (USAFSAM/VNL), and by Dr. Ronald Lawter of Abcor, Inc.

REFERENCES

1. Analytical Method P&CAM 248, Hydrazine compounds in air. In: D.G. Taylor (coordinator), NIOSH manual of analytical methods, 2nd ed., vol. 1. DHEW (NIOSH) Publication No. 77-157-A. US Department of Health, Education, and Welfare, Cincinnati, Ohio, 1977.
2. Analytical Method S237, Hydrazine. In: D.G. Taylor (coordinator), NIOSH manual of analytical methods, 2nd ed., vol. 3. DHEW (NIOSH) Publication No. 77-157-C. US Department of Health, Education, and Welfare, Cincinnati, Ohio, 1977.

3. Campbell, E.E., et al. Development of air-sampling techniques. Los Alamos Scientific Laboratory Report LA-6057-PR, Sept 1975.
4. Diamond, P., and A.A. Thomas. Determination of 1,1-dimethylhydrazine (UDMH) in urine. 6570th Aerospace Medical Research Laboratories, AFSC, Wright-Patterson AFB, Ohio. AMRL-TDR-62-119, Oct 1962.
5. GASBADGETM hydrazine dosimeter--use and analysis instructions. Abcor, Inc, Wilmington, Mass., 1978.
6. Knudsen, J.G., and D.L. Katz. Fluid dynamics and heat transfer. New York: McGraw-Hill, 1968.
7. Nelson, G.O. Controlled test atmospheres, pp. 69-70. Ann Arbor, Mich.: Ann Arbor Science Publishers, 1972.
8. Reid, R.C., and T.K. Sherwood. Properties of gases and liquids. New York: McGraw-Hill, 1968.
9. Wood, G.O., and R.G. Anderson. Sampling and analysis of hydrazine compounds in air. Los Alamos Scientific Laboratory Report LA-UR-75-1785, May 1976.
10. Wood, G.O., and J.W. Nickols. Sampling and analysis of organic bases in air. Los Alamos Scientific Laboratory/NIOSH Report LA-UR-77-1954, May 1978.
11. Wood, G.O. Sampling and analysis of hydrazine compounds. Unpublished data.

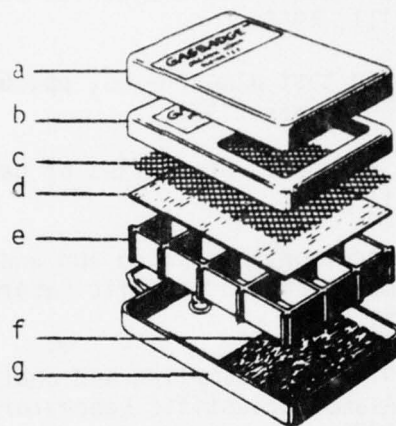

- a. Cover
- b. Front with opening to allow diffusion of gases or vapors into dosimeter
- c. Protective screen
- d. Replaceable draft shield
- e. Open grid to define diffusion geometry
- f. Replaceable collection element
- g. Dosimeter back with spring clip

Figure 1. Dosimeter components. (Replaceable aluminum sealing tape and exposure information label are not shown).

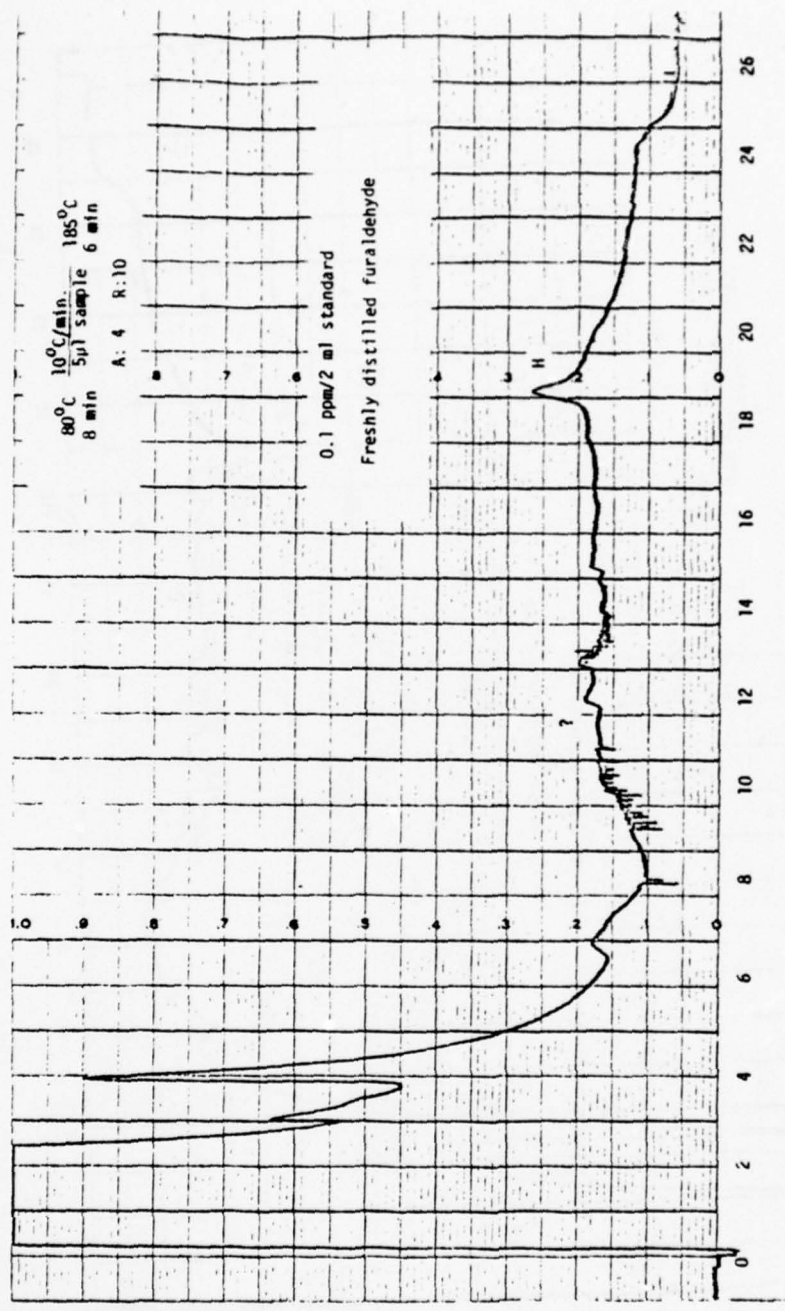

Figure 2. Chromatogram of 0.1 ppm UDMH, MMH, and H -- furfuraldehyde method.

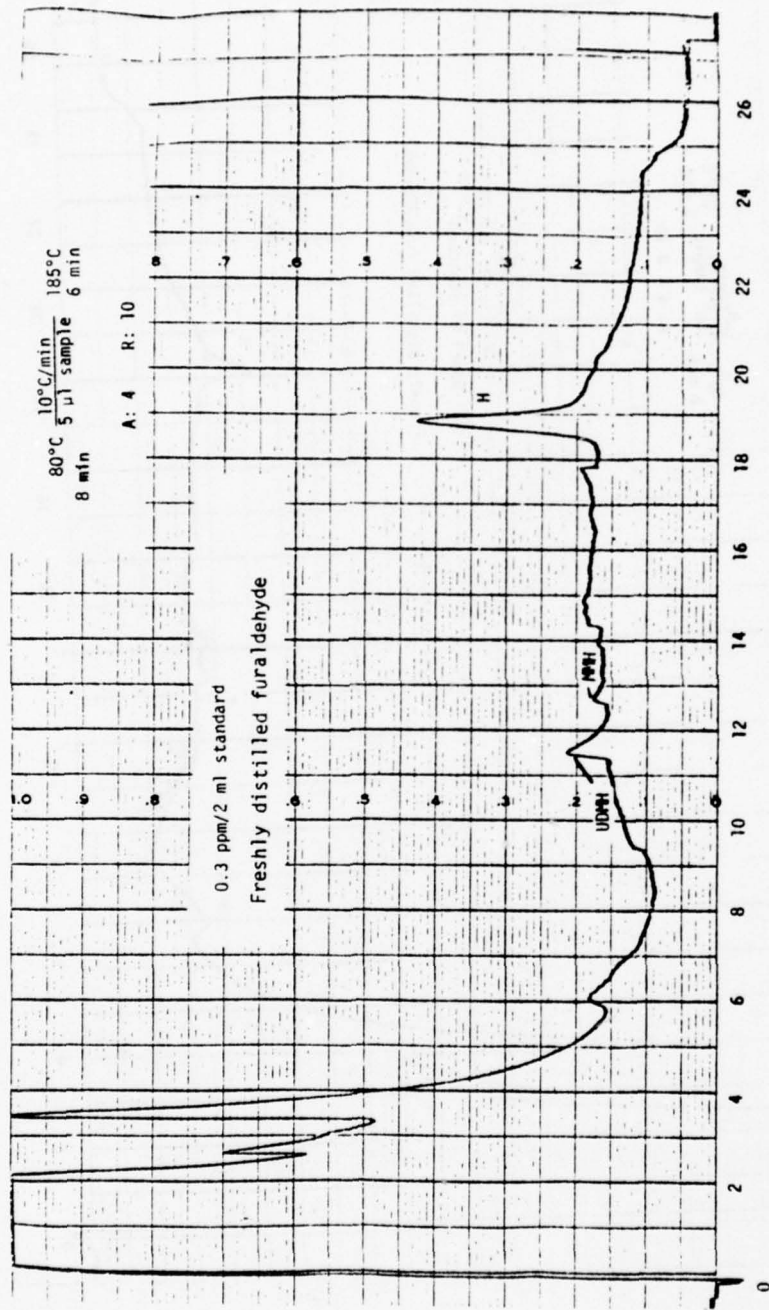

Figure 3. Chromatogram of 0.3 ppm UDMH, MMH, and H -- furfuraldehyde method.

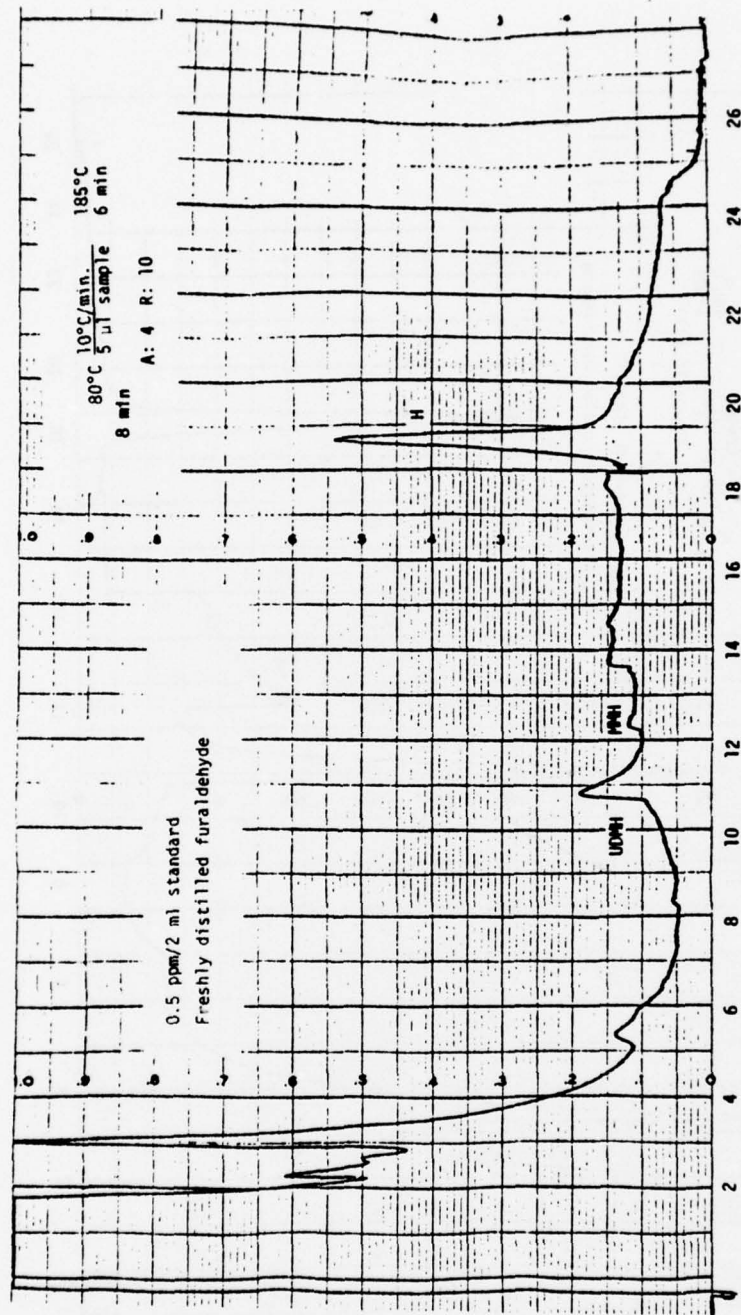

Figure 4. Chromatogram of 0.5 ppm UDMH, MMH, and H -- furfuraldehyde method.

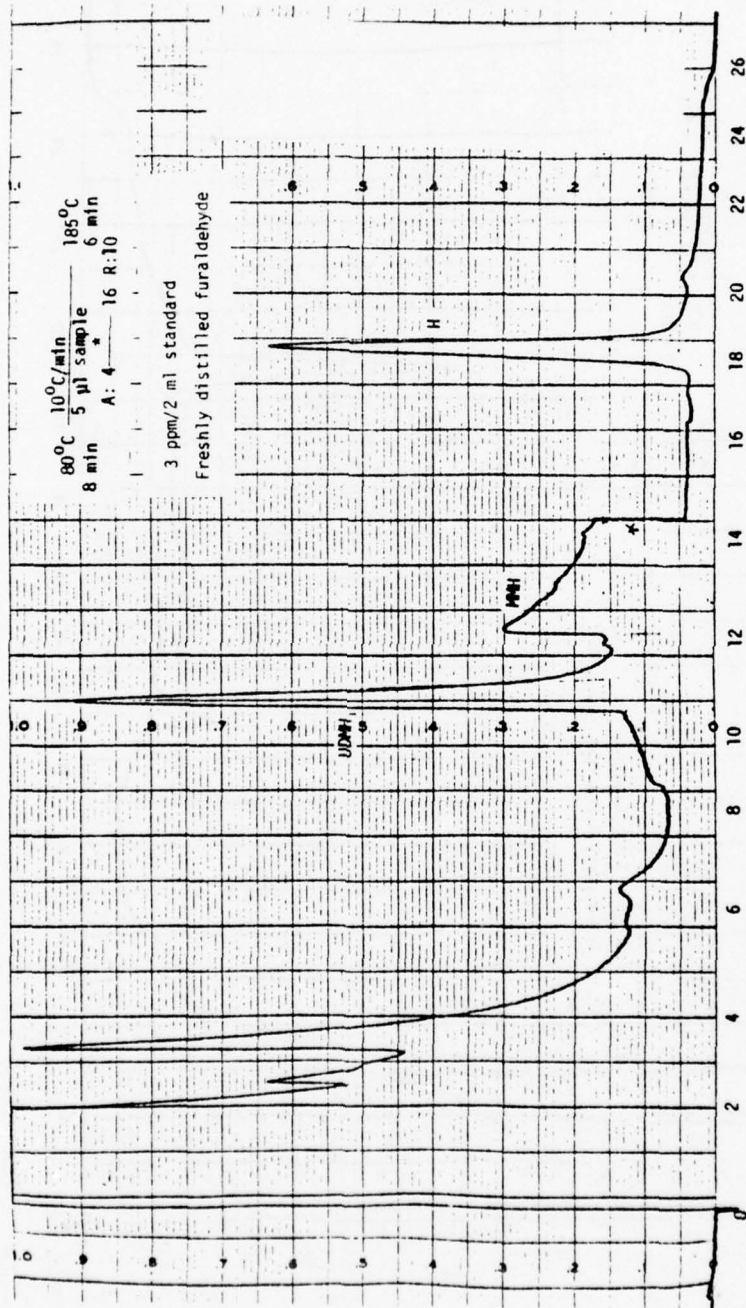

Figure 5. Chromatogram of 3 ppm UDMH, MMH, and H -- furfuraldehyde method.

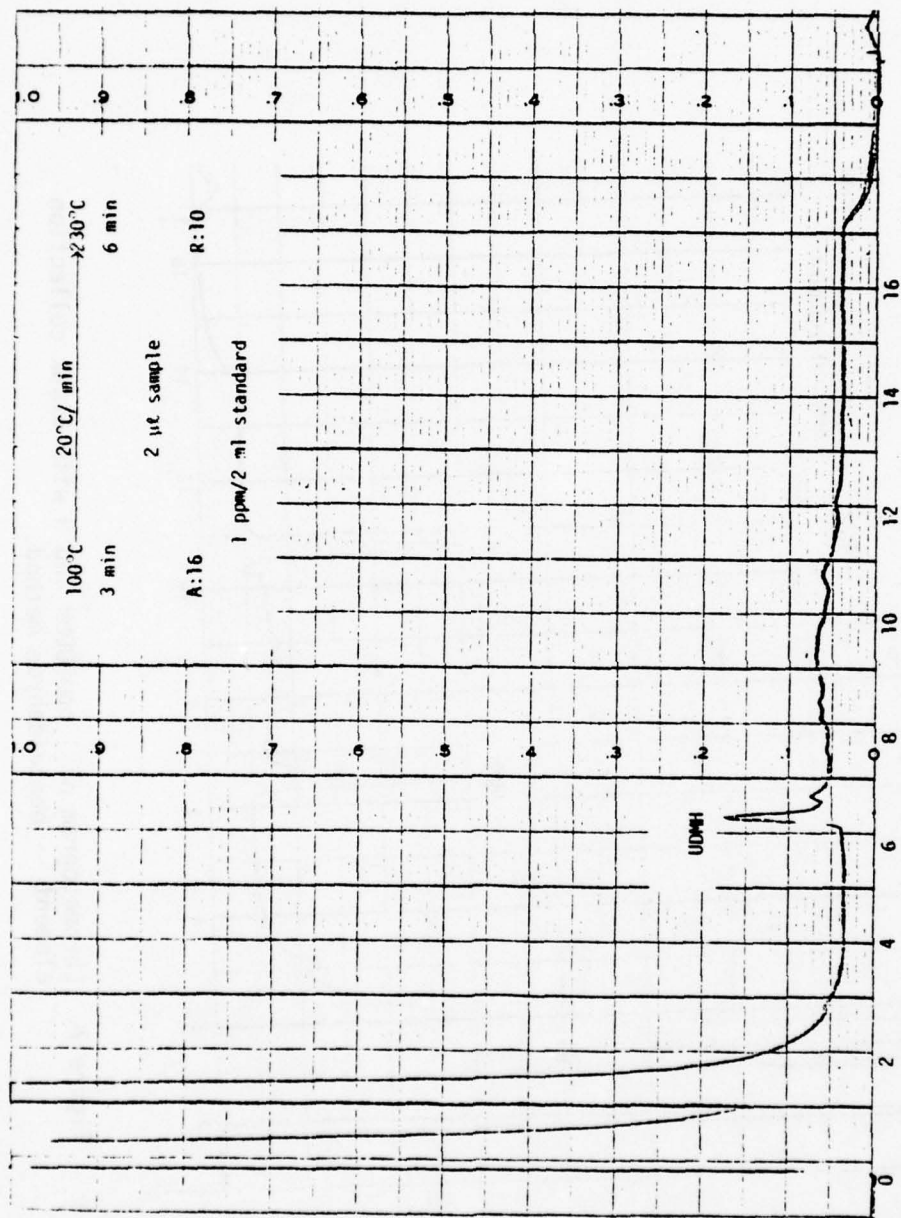

Figure 6. Chromatogram of 1 ppm UDMH and H -- benzaldehyde method.

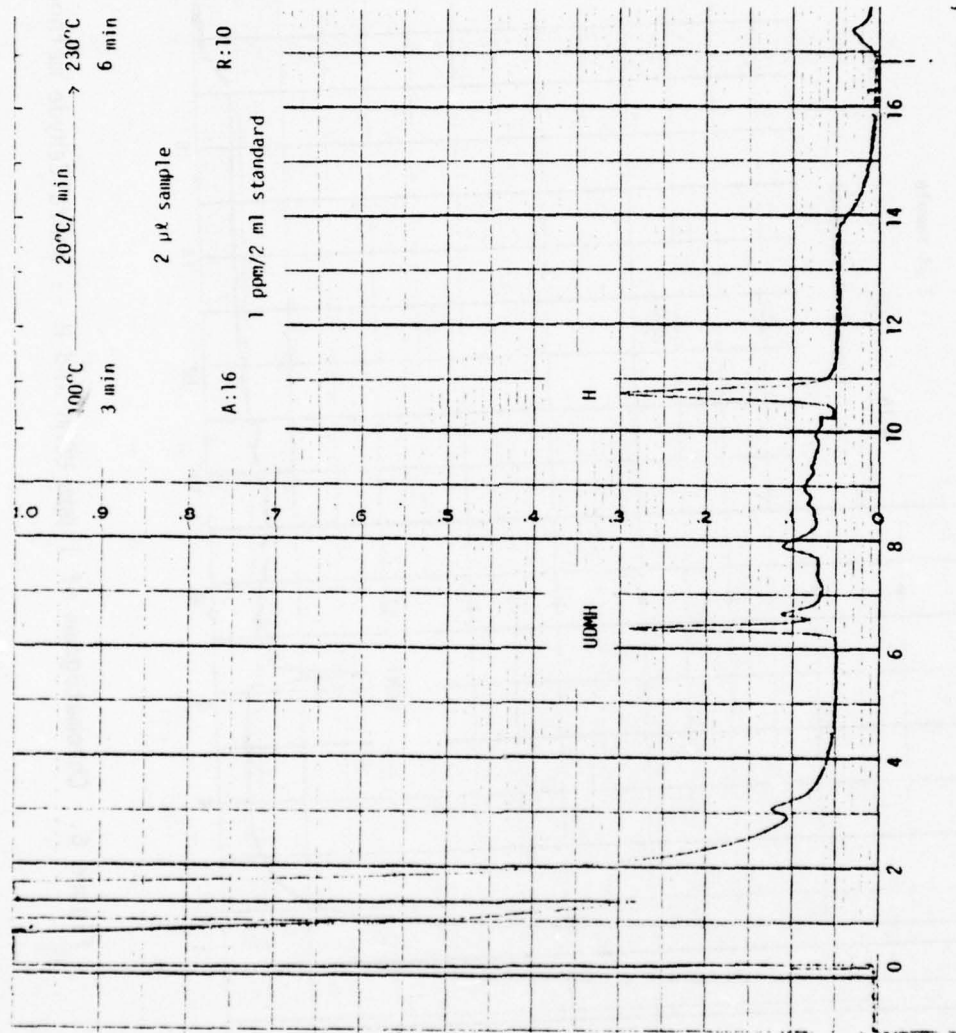

Figure 7. Chromatogram of 1 ppm UDMH and H with blank collection element -- benzaldehyde method.

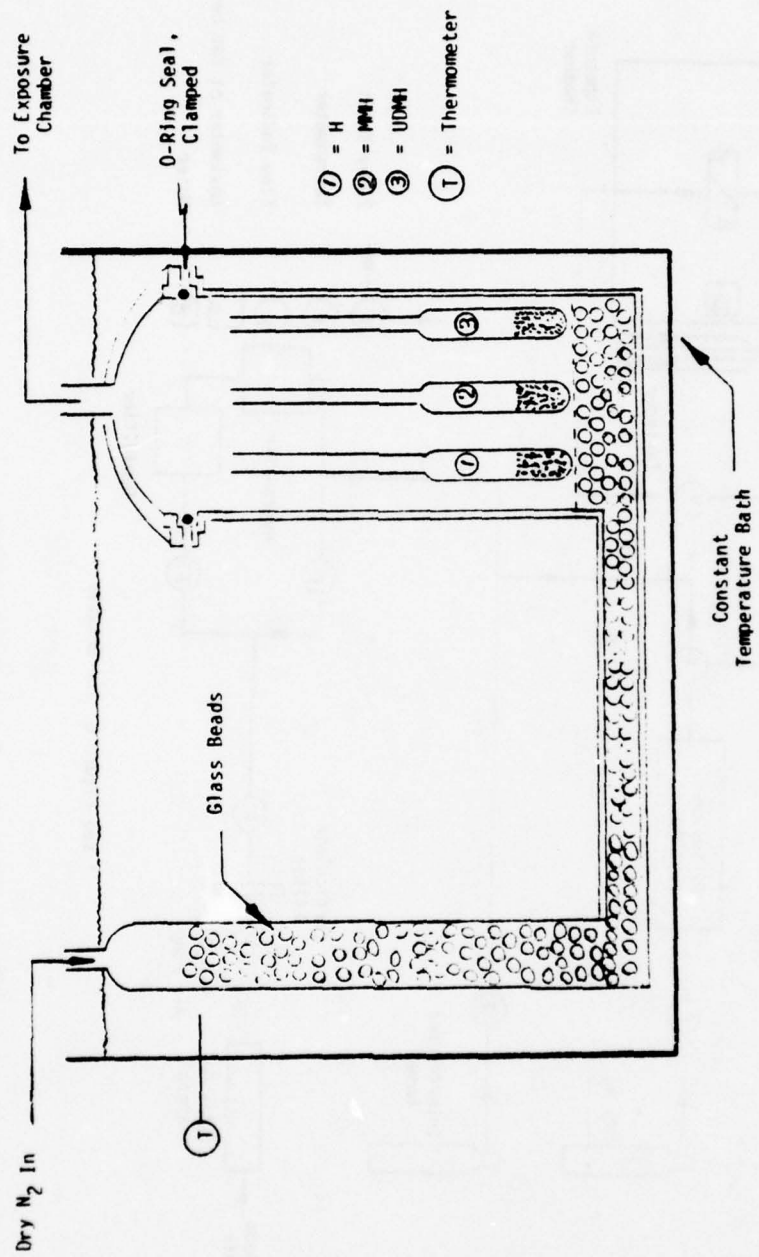
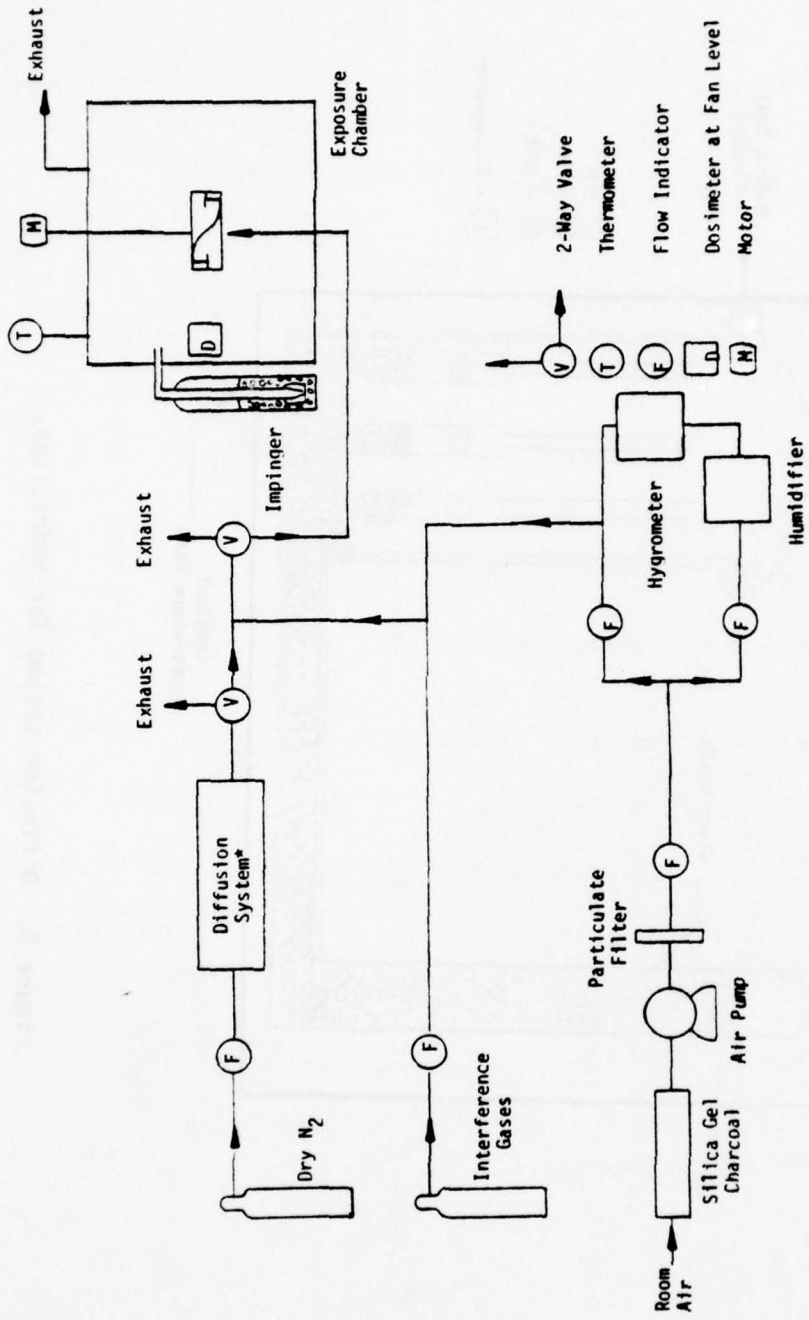

Figure 8. Diffusion system for hydrazines.



* see Figure 8 for details

Figure 9. Flow schematic of exposure system.

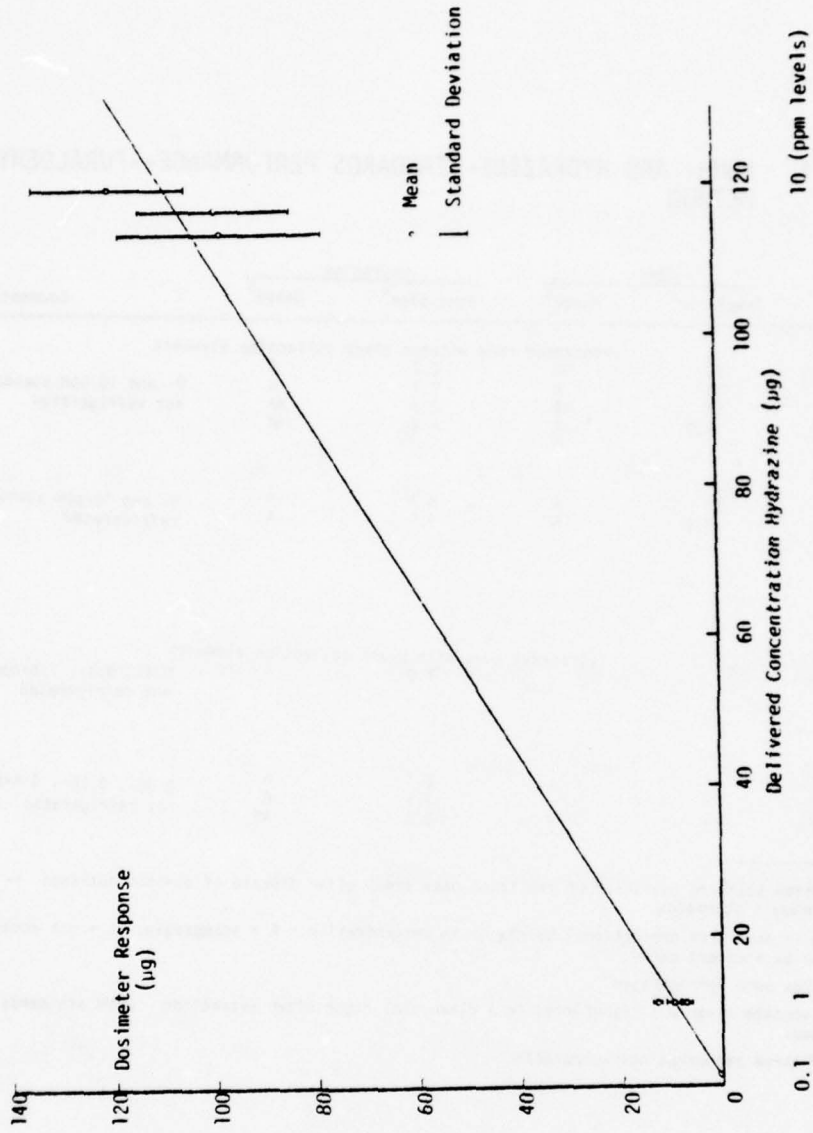

Figure 10. Linearity plot: hydrazine GASBADGETM dosimeter.

TABLE 1. UDMH- AND HYDRAZINE-STANDARDS PERFORMANCE--FURALDEHYDE GC METHOD

Analysis date	UDMH		Hydrazine		Comments
	Precision ^a	Range ^b	Precision ^a	Range ^b	
Programmed runs without blank collection elements					
4/14/78	15	NA	2.2	A	
4/17/78	13	A	7.1	A	8- and 10-ppm standards -
4/18/78	14	NA	2.9	NA	not refrigerated
4/20/78 ^c	8.0	A	4.4	NA	
4/21/78	17	A	8.4	A	5- and 10-ppm standards -
4/24/78	6.8	A	9.8	A	refrigerated
Isothermal runs with blank collection elements					
10/11/78	-	-	1.0	A	0.4-, 0.8-, 1.6-ppm standards ^d - not refrigerated
9/28/78	-	-	4.7	A	0.08-, 0.16-, 0.4-ppm standards ^d - not refrigerated
9/29/78	-	-	3.5	A	
10/10/78	-	-	3.3	A ^e	

^a % relative standard deviation of replicate peak areas after discard of obvious outliers -- average RSD of each day's standards.

^b Change in peak area proportional to change in concentration. A = acceptable, NA = not acceptable for use as standard curve.

^c Standards were refrigerated

^d Ethyl acetate layer was transferred to a clean vial right after extraction. UDMH standards not used.

^e One of three standards not acceptable.

TABLE 2. DIFFUSION TUBE SYSTEM FOR GENERATING HYDRAZINE STANDARDS

Conc. (ppm)	Temp. °C	Flow rate ^a (lpm)	Chemical	Tube dimensions ^b	
				diameter (mm)	length (cm)
10	50	5	UDMH Hydrazine	2	3.5
				5	3.0 ^c
				5	2.0 ^d
1	40	6	Hydrazine	2	1.4
0.1g	40 ^e , 30 ^f	10	UDMH Hydrazine	0.5	4.0
				1	4.0 ^e
				2	3.5 ^f

^a Total dilution flow used to deliver stated concentration to the exposure chamber.

^b Dimensions refer to the bore of the diffusion tube.

^c Runs 1-3.

^d Runs 4-6.

^e Runs 1 and 2.

^f Runs 3-10.

^g 0.14 ppm generated for actual 3-hour exposures.

TABLE 3. EXPERIMENTAL DIFFUSION RATES

Run	Time (min)	10-ppm Level				Comments
		UDMH		H		
		loss (g)	R (ng/min)	loss (g)	R (ng/min)	
1	1340	--		--		liquid in capillary
2	3861	0.4636	120,000	0.1811	47,000	
3	7272	0.8435	116,000	0.3483	48,000	
4	7387	0.9159	124,000	0.4798	65,000	H-tube cut to 2 cm
5	12700	1.5333	121,000	0.7954	63,000	UDMH tube refilled
6	6868	0.9057	132,000	0.4512	63,000	
	7200					

Run	Time (min)	1-ppm Level		Comments
		loss (g)	R (ng/min)	
1	4436	0.0348	7,800	40°C
2	4366	0.0324	7,400	H-tube cut to 1.4 cm
3	5532	0.0418	7,600	No UDMH tube

Run	Time (min)	0.1-ppm Level				Comments	
		UDMH		H			
		loss (g)	R (ng/min)	loss (g)	R (ng/min)		
1	6398	0.0403	5,800	0.0053	760	40°C	
2	11011	0.0656	6,000	0.0082	740		
3	9872	0.0318	3,200	0.0193	2,000	Larger tube for H 30°C	
4	9997	0.0307	3,100	0.0177	1,800		
5	40364	0.1192	3,000	0.0787	1,900		
6	7173	0.0225	3,100	0.0134	1,900		
7	19609	0.0604	3,100	0.0355	1,800		
8	8362	0.0258	3,100	0.0146	1,700		
9	18650	0.0494	2,600	0.0305	1,600		
10	10329	--	--	0.0193	1,900		UDMH tube removed

TABLE 4. EXPERIMENTAL DIFFUSION COEFFICIENTS^a OF HYDRAZINES
IN AIR AT 25°C, 760 mm Hg

10-ppm Level

Run #	UDMH	H
1	not calculated	not calculated
2	0.10	0.11
3	0.095	0.11
4	0.10	0.097
5	0.096	0.092
6	0.10	0.089

1-ppm Level

Run #	H
1	0.087
2	0.082
3	0.084

0.1-ppm Level

Run #	UDMH	H
1	0.14	0.089
2	0.15	0.088
3	0.14	0.096
4	0.13	0.084
5	0.13	0.090
6	0.13	0.090
7	0.14	0.093
8	0.15	0.091
9	0.11	0.082
10	--	0.091
Theoretical Values ^b	0.10	0.15

^a Calculated following Analytical Instrument Development, Inc., Application Note 204A, "Developing TLV Level Standards - Diffusion Tubes," p. 12, adapted from A.P. Altshuller & I.R. Cohen, Anal Chem 32: 802 (1960)

^b Calculated following the Wilke and Lee Modification of the Hirschfelder, Bird, and Spotz equation as given in R.H. Perry and C.H. Chilton, Advisors, "Chemical Engineers Handbook," 5th ed., p. 3-231 (1973).

TABLE 5. STATISTICAL EVALUATION OF HYDRAZINE DOSIMETER PERFORMANCE

Exposure date	Analysis method	Delivered concentration	Mean dosimeter response ^a (μg)	Mean standard deviation	Mean coefficient of variation ^b
4/13/78	GC	10-ppm level ^c 120 μg	120	30	0.25
4/17/78	GC	114 μg	98	40	0.41
4/18/78	GC	117 μg	99	30	0.30
10/3/78	GC	1-ppm level ^d 11 μg	9.6	3.2	0.33
	Col.		7.6	1.2	0.16
10/4/78	GC	11 μg	13.0	1.8	0.14
	Col.		8.3	1.8	0.22
10/5/78	GC	11 μg	7.2	2.2	0.31
	Col.		8.8	1.3	0.15
9/21/78	GC	0.1-ppm level ^d 1.3 μg	0.70	0.36	0.51
	Col.		0.83	0.16	0.19
9/22/78	GC	1.3 μg	0.77	0.58	0.75
	Col.		0.70	0.09	0.13
9/23/78	GC	1.3 μg	1.1	0.48	0.44
	Col.		1.1	0.15	0.14

a. Mean of 10 dosimeters on each exposure day

b. Coefficient of variation = $\frac{\text{standard deviation}}{\text{dosimeter response}}$

c. Programmed furfuraldehyde GC analysis

d. Isothermal furfuraldehyde GC analysis, PDA8 colorimetric analysis

APPENDIX A: ANALYTICAL RESULTS

TABLE A-1. STATISTICAL EXPOSURES AT 10 ppm
HYDRAZINE ANALYSIS OF DOSIMETERS AND IMPINGERS EXPOSED TO 10 ppm HYDRAZINE AND UDMH

Exposure date	Dosimeter #	Expected value (µg)	µg Found	Furaldehyde_GC-Programmed % Expected value	Comments
4/13/78	1	120	67	56	Analyzed 4/14
	2	120	113	94	
	3	120	103	86	
	4	120	113	94	
	5	120	108	90	
	6	120	107	89	
	7	120	158	132	
	8	120	135	112	
	9	120	175	146	
	10	120	118	98	
	11 (Blank)	0	0	-	
	12 (Blank)	0	0	-	
Impinger A	86	86	12	14	Analyzed 4/14
	88	88	7	8	
	92	92	17	18	
4/17/78	13	114	76	67	Analyzed 4/18
	14	114	10	9	
	15	114	114	100	
	16	114	125	110	
	17	114	137	120	
	18	114	156	137	
	19	114	131	115	
	20	114	104	91	
	21	114	176	154	
	22	114	93	82	
	23 (Blank)	0	0	-	
	24 (Blank)	0	0	-	
Impinger A	83	83	27	33	Analyzed 4/18
	85	85	6	7	
	89	89	12	13	

TABLE A-1 (Continued)
 HYDRAZINE ANALYSIS OF DOSIMETERS AND IMPINGERS EXPOSED TO 10 ppm HYDRAZINE AND UDMH

Exposure date	Dosimeter #	Expected value (ug)	Formaldehyde GC-Programmed µg Found	% Expected value	Comments	
4/18/78	25	117	59	50	Analyzed 4/21 directly from refrigerator	
	26		80	68		
	27		120	103		
	28		108	92	Analyzed 4/24 directly from refrigerator. #34 covered during exposure.	
	29		85	73		
	30		155	132		
	31		113	97	Analyzed 4/21 directly from refrigerator B&C visibly clogged.	
	32		104	89		
	33		66	56		
		34		-	4	Analyzed 4/21
		Impinger A	85	3	-	directly from refrigerator
		Impinger B	87	-	-	B&C visibly clogged.
		Impinger C	91	-	-	Analyzed 4/21
		35 (Blank)	0	-	-	Analyzed 4/24
		36 (Blank)	0	-	-	

TABLE A-2. STATISTICAL EXPOSURES AT 1 ppm
HYDRAZINE ANALYSIS OF DOSIMETERS AND IMPINGERS EXPOSED TO 1 ppm HYDRAZINE

Exposure date	Dosimeter #	Expected value (µg)	Euraldehyde		GC-Isothermal		PDAB Colorimetric		Comments
			µg Found	% Expected value	µg Found	% Expected value	µg Found	% Expected value	
10/ 3/78	I	11					8.3	75	Colorimetric analysis of impingers 10/3, of dosimeters 10/6. GC analysis 10/10.
	II						5.4	49	
	III						8.3	75	
	IV						8.0	73	
	V						7.8	71	
	VI				8.0	73			
	VII				6.5	59			
	VIII				14	127			
	IX				7.5	68			
	X				12	109			
	Impinger A			266			152	57	
	B			298			170	57	
	C			254			144	57	
10/ 4/78	XVI	11					9.9	90	Colorimetric analysis of impingers 10/4, of dosimeters 10/6. GC analysis of dosimeters XXIII-XXV 10/10, others 10/11.
	XVII						10	91	
	XVIII						7.7	70	
	XIX						8.3	75	
	XX						5.6	51	
	XXIII				14	127			
	XXIV				12	109			
	XXV				14	127			
	XXVI				9.9	90			
	XXVII				14	127			
	Impinger A			285			148	52	
	B			308			178	58	
	C			267			148	55	

TABLE A-2 (Continued)
HYDRAZINE ANALYSIS OF DOSIMETERS AND IMPINGERS EXPOSED TO 1 ppm HYDRAZINE

Exposure date	Dosimeter #	Expected value (µg)	Furaldehyde		GC-Isothermal		PDAB Colorimetric		Comments
			µg Found	% Expected value	µg Found	% Expected value	µg Found	% Expected value	
10/ 5/78	XL I	11					10	91	Colorimetric analysis of impingers 10/5 of dosimeters 10/6. GC analysis 10/11.
	XL II					6.9	63		
	XL III					9.0	82		
	XL IV					10	91		
	XL V					8.0	73		
	XL VI				11	100			
	XL VII				6.2	56			
	XL VIII				5.4	49			
	XL XIX				6.7	61			
	L				6.9	63			
	Impinger A			287			190	66	
	B			314			186	59	
	C			279			180	64	

TABLE A-3. STATISTICAL EXPOSURES AT 0.1 ppm
HYDRAZINE ANALYSIS OF DOSIMETERS AND IMPINGERS EXPOSED TO 0.1 ppm HYDRAZINE

Exposure date	Dosimeter #	Expected value (µg)	Furaldehyde µ Found	GC-Isothermal % Expected value	PDA6 Colorimetric µ Found	% Expected value	Comments
9/21/78	I	1.3			0.86	66	Colorimetric analysis of dosimeters 9/26. Colorimetric analysis of impingers on 9/21 invalid because of improper standard makeup. Stored impinger solutions analyzed on 9/25; not enough solution A to analyze. GC analysis 9/28.
	II			0.91	70		
	III			0.82	63		
	IV			0.56	43		
	V			1.0	77		
	VI		22				
	VII		35				
	VIII		70				
	IX		52				
	X		92				
9/22/78	Impinger A	1.3			N.A.		
	B		32	103			
	C		32	103			
9/22/78	XVI	1.3			0.71	55	Same colorimetric analysis comments as 9/21 exposure; not enough solution B to analyze. GC analysis of dosimeters XXXI, XXXII on 9/28, others 9/29.
	XVII			0.78	60		
	XVIII			0.80	62		
	XIX			0.63	48		
	XX			0.60	46		
	XXXI		12				
	XXXII		63				
	XXXIII		131				
	XXXIV		36				
	XXXV		56				
9/22/78	Impinger A	1.3			20	59	
	B		N.A.				
	C		19	56			

N.A. = Not Analyzed

TABLE A-3. (Continued)
HYDRAZINE ANALYSIS OF DOSIMETERS AND IMPINGERS EXPOSED TO 0.1 ppm HYDRAZINE

Exposure date	Dosimeter #	Expected value (ug)	Furaldehyde ug Found	GC-Isothermal % Expected value	PDAB ug Found	Colorimetric % Expected value	Comments	
9/23/78	2	1.3			1.0	77	Colorimetric analysis of dosimeters 9/26; colorimetric analysis of impingers 9/25. Impinger B solution spilled. GC analysis 9/29.	
	6				1.1	85		
	7				1.2	92		
	8				1.3	100		
	26				0.91	70		
	XXIII		0.64	49				
	XXIV		0.94	72				
	XXV		0.94	72				
	XXVI		0.98	75				
	XXVII		1.9	146				
	Impinger A			35		20		56
	B			35		N.A.		
	C			32		4.0		12

M.A. = Not analyzed

TABLE A-4. HYDRAZINE ANALYSIS OF DOSIMETERS STORED AFTER EXPOSURE TO 10 ppm HYDRAZINE AND UDMH

Exposure date	Dosimeter #	Expected value (ug)	Furaldehyde μg Found	GC-Programmed % Expected Value	Comments
4/21/78	3	114	200	175%	Analyzed 5/26/78
	4	↓	168	147%	
4/24/78	5	111	184	166	Analyzed 5/26/78
	13	↓	137	123	
	14	↓	168	151	
	15	↓	153	138	

TABLE A-5. BENZALDEHYDE GC METHOD EVALUATION
 HYDRAZINE ANALYSIS OF DOSIMETERS AND IMPINGERS EXPOSED TO 0.25 ppm HYDRAZINE AND UDMH

Exposure date	Dosimeter #	Expected value (µg)	µg Found	Benzaldehyde GC % Expected value	µg Found	Colorimetric % Expected value	Comments
8/1/78	1	3.5	1.8	51			No impinger samples. Programmed GC analysis 8/2. Poor results on GC standards. Colorimetric analysis 8/7 on dosimeters desorbed in beakers.
	2		2.5	71			
	3		0.17	5			
	4		0.17	5			
	5					0	
8/3/78	6					0	No impinger samples. Programmed GC analysis 8/4 Good results on GC standards, reproducible results on dosimeters. Desorbed solution removed from collection element before derivatizing. Colorimetric analysis 8/7 on dosimeters desorbed in beakers. Dosimeters 10, 11, 12 desorbed on 8/3 in capped vials; stored desorption solution analyzed colorimetrically on 8/7.
	7					0	
	8					0	
	10	3.5	0.43	12		0	
	11		0.35	10		0	
	12		0.28	8		0	
	13		0.35	10		0	
	14		0.32	9		0	
	15					0	
	16					0	

TABLE A-5 (Continued)
 HYDRAZINE ANALYSIS OF DOSIMETERS AND IMPINGERS EXPOSED TO 0.25 ppm HYDRAZINE AND UDMH

Exposure date	Dosimeter #	Expected value (µg)	Benzaldehyde GC		PDAB Colorimetric		Comments
			µg Found	% Expected value	µg Found	% Expected value	
8/8/78	21	3.5	4.4	126			Programmed GC analysis 8/9. Same comments as 8/3 except poor results on GC standards. Colorimetric analysis 8/16 on dosimeters desorbed in capped test tubes.
	22		3.9	111			
	23		3.3	94			
	24		N.R.				
	25		5.6	160	3.4	97	
	26				4.3	123	
	27				2.8	80	
Impinger A	89			65	73		
	B			77	79		
	C			76	84		
8/10/78	1	3.5	N.D.				Isothermal GC analysis 8/14 on solutions derivatized 8/10 and stored in freezer. Same GC comments as 8/3 except very poor results on standards, perhaps caused by storage. No colorimetric H analysis.
	2		N.D.				
	3		1.9	54			
	4		2.2	63			
	5		N.D.				

N.R. = Not reproducible
 N.D. = Not detectable

TABLE A-6. UDMH ANALYSIS OF DOSIMETERS AND IMPINGERS EXPOSED TO 10 ppm HYDRAZINE AND UDMH

Exposure date	Dosimeter #	Expected value (µg)	µg Found	Furaldehyde GC-Programmed % Expected value	Comments
4/13/78	1	239	32	13	Analyzed 4/14
	2		73	31	
	3		50	21	
	4		33	14	
	5		50	21	
	6		31	13	
	7		18	8	
	8		306	128	
	9		149	62	
	10		72	30	
	11 (Blank)		0	-	
	12 (Blank)		0	-	
	Impinger A		165	39	
	Impinger B		169	40	
Impinger C	176	37			
4/17/78	13	228	266	117	Analyzed 4/18
	14		497	218	
	15		140	61	
	16		445	195	
	17		451	198	
	18		68	30	
	19		264	116	
	20		274	120	
	21		112	49	
	22		113	50	
	23 (Blank)		0	-	
	24 (Blank)		0	-	
	Impinger A		160	80	
	Impinger B		164	30	
Impinger C	171	40			

TABLE A-6. (Continued)
UDMH ANALYSIS OF DOSIMETERS AND IMPINGERS EXPOSED TO 10 ppm HYDRAZINE AND UDMH

Exposure date	Dosimeter #	Expected value (µg)	Furaldehyde GC-Programmed		Comments
			µg found	% Expected value	
4/18/78	25	233	215	92	Analyzed 4/21 directly from refrigerator
	26		274	118	
	27		38	16	
	28		150	64	
	29	56	24		
	Blank	0	-		
	30	0	115	49	Analyzed 4/24 from refrigerator; #34 covered during exposure
	31		272	117	
	32		246	106	
	33		143	61	
	34		-	-	
	Blank		0	-	
	Impinger A	0	65	40	Analyzed 4/21 directly from refrigerator; B&C visibly clogged
	Impinger B		-	-	
Impinger C	-		-		

TABLE A-7. UDMH ANALYSIS OF DOSIMETERS STORED AFTER EXPOSURE TO 10 ppm HYDRAZINE AND UDMH

Exposure date	Dosimeter #	Expected value (µg)	Furaldehyde		GC-Programmed		IPF Colorimetric		Comments
			µg Found	% Expected value	µg Found	% Expected value	µg Found	% Expected value	
4/21/78	3	274	372	136	140	51	Colorimetric analysis 5/24/78		
	4	↓	372	136	244	89	GC analysis 5/26/78		
4/24/78	5	268	416	155	242	90	Colorimetric analysis 5/24/78		
	13	↓	263	98	262	98	GC analysis 5/26/78		
	14	↓	416	155	228	85			
	15	↓	328	122	190	71			

TABLE A-8. BENZALDEHYDE GC METHOD EVALUATION
UDMH ANALYSIS OF DOSIMETERS AND IMPINGERS EXPOSED TO 0.25 ppm HYDRAZINE AND UDMH

Exposure date	Dosimeter #	Expected value (µg)	Benzaldehyde GC		µg Found	IPF	Colorimetric	Comments
			% Expected	Value				
8/1/78	1	9.1	N.R.					No impinger samples. Programmed GC analysis 8/2. Poor results on GC standards. No colorimetric UDMH analysis.
	2	↓	2.3					
	3	↓	2.7					
	4	↓	4.6					
8/3/78	10	8.7	0.79	9				No impinger samples. Programmed GC analysis 8/4. Desorbed solution removed from collection element before derivatizing. Same GC comments as 8/1.
	11	↓	0.96	11				
	12	↓	0.87	10				
	13	↓	0.89	10				
	14	↓	0.89	10				
8/8/78	21	8.7	0.29	3				Programmed GC analysis 8/9. Same GC comments as 8/3. No colorimetric analysis.
	22	↓	0.38	4				
	23	↓	0.69	8				
	24	↓	0.61	7				
	25	↓	1.01	12				
8/10/78	1	8.8	N.D.	57				Isothermal GC analysis 8/11. Same GC comments as 8/3. Colorimetric analysis 8/17 on dosimeters desorbed in capped test tubes.
	2	↓	5.0	34				
	3	↓	3.0					
	4	↓	N.D.					
	5	↓	N.D.					
8/10/78	6	8.8			4.2	48		
	7	↓			1.5	18		
	8	↓			3.5	40		
Impinger	A	149			45	30		
	B	176			67	38		
	C	156			73	47		

N.D. = Not detectable
N.R. = Not reproducible

TABLE A-9. TPF COLORIMETRIC METHOD EVALUATION
 UDMH ANALYSIS OF DOSIMETERS AND IMPINGERS EXPOSED TO 0.1 ppm HYDRAZINE AND UDMH

Exposure date	Dosimeter #	Expected value (µg)	µg Found	TPF Colorimetric % Expected value	Comments	
9/1/78	11	5.3 ↓	5.0	94	Colorimetric analysis on impingers 9/1, on dosimeters 9/6. Dosimeters contained usual collection elements. Colorimetric analysis 9/6. Collection elements impregnated with 1N H ₂ SO ₄ ; standards contained unexposed collection elements impregnated with 1N H ₂ SO ₄ . (Usual collection element impregnated with 5N H ₂ SO ₄ .) Colorimetric analysis on impingers 9/7, on dosimeters 9/8. Dosimeters contained usual collection elements which were desorbed and brought to pH 5.4 without using any buffer. Standard curve made up the same way.	
	12		4.5	85		
	13		4.6	87		
	14		5.5	104		
	15		3.4	64		
	Impinger A	77	73	75		
	B	85	64	75		
	C	80	59	74		
	9/1/78	1	5.3 ↓	12		226
		2		21		396
		3		16		302
		4		14		264
		5		12		226
		11	3.5 ↓	3.0		86
		12		9.3		266
13		11		314		
14		20		571		
15		8.7		249		
Impinger A		66	65	66		
B		74	49	66		
C		69	43	62		

APPENDIX B: CALCULATIONS

TABLE B-1. COLLECTION-ELEMENT CAPACITY FOR HYDRAZINE ADSORPTION

An average of 0.35g of 5N H₂SO₄ was absorbed by the Pellon coupons. 5N H₂SO₄ contains 21.3% H₂SO₄ (extrapolated from H₂SO₄ specific gravity table)

$$\frac{0.35 \times 0.213}{98.08} = 7.6 \times 10^{-4} \text{ M H}_2\text{SO}_4$$

The maximum amount of hydrazine that can be adsorbed is:

$$7.6 \times 10^{-4} \times 32 = 0.0243 \text{ g}$$

For a 4-hour exposure at 25°C at 760 mm Hg, 0.0243g hydrazine collected on a dosimeter would equal the time-weighted average ambient concentration (C_∞) shown below:

$$\begin{aligned} C_{\infty} &= \frac{\mu\text{g collected}}{\text{MW}} \times 3360 \times \frac{1}{D_{25} \times 14400} \\ &= \frac{0.0243 \times 10^6}{32} \times 3360 \times \frac{1}{0.091 \times 14400} \\ C_{\infty} &= 1950 \text{ ppm} \end{aligned}$$

TABLE B-2. CALCULATION OF DIFFUSION COEFFICIENTS

Experimental results (Analytical Instrument Development):

R	$= 6.169 \times 10^6 D_o M \left(\frac{A}{L}\right) \left(\frac{T}{T_o}\right)^{m-1} \log \frac{P}{P-p}$	
R	= diffusion rate at T	ng/min
D_o	= diffusion coefficient at 0°C and 760 mm Hg	cm ² /sec
M	= molecular weight of diffusing vapor	g
P	= total pressure - 1 atm.	mm Hg
A	= (cross-sectional area diffusion path =) (cross-sectional area of capillary)	cm ²
L	= length of diffusion path = length of capillary	cm
T	= temperature in diffusion chamber	°K
T_o	= T at standard conditions, 0°C	°K
P	= (partial pressure of sample at T =) (vapor pressure of compound at T)	mm Hg
m	= 3/2	

To convert D_o into D at another temperature,

$$D_T = D_o \left(\frac{T}{273}\right)^{3/2} \left(\frac{760}{P}\right)$$

Theoretical diffusion coefficients (Wilke and Lee):

$$D = \frac{BT^{3/2} \sqrt{(1/M_1) + (1/M_2)}}{Pr^2 12 I_D}$$

D	= diffusion coefficient at T of interest	cm ² /sec
B	= $(10.85 - 2.50 (1/M) + (1/M_2) \times 10^{-4})$	
T	= temperature of interest, here 25°C	°K
M_1	= molecular weight of diffusive vapor	g
M_2	= molecular weight of air	g
P	= absolute pressure	atm
r_{12}	= $\frac{(r_o)_1 + (r_o)_2}{2}$ = collision diameter	Å
r_o	= $1.18 V_b^{1/3}$	Å
V_b	= molal volume of liquid at boiling point	cm ³ /g-mole
I_d	= collision integral for diffusion	

Tables of collision diameters, molal volumes, and collision integrals are given in Perry's "Chemical Engineer's Handbook."

TABLE B-3. EXPOSURE TEST SYSTEM CALCULATIONS

Concentration delivered to exposure chamber, C_E

$$C_E = \frac{\text{diffusion rate}}{\text{total dilution flow}} = \frac{\text{ng/min}}{\text{ml/min}} = \frac{\text{ng}}{\text{ml}}$$

$$C_E = \frac{C_E \text{ ng/ml} (22400 \times \frac{T}{T_o} \times \frac{P_o}{P})}{1000 \times \text{MW}}$$

- T = Exposure chamber temperature in °K
 P = Ambient pressure in mm Hg assumed = chamber pressure
 MW = Molecular weight

Expected mass collected in impingers, μg_I

$$\mu\text{g}_I = \frac{C_E \text{ ng/ml}}{1000} \times \frac{\text{flow through impinger}}{\text{in ml/min}} \times \frac{\text{time sampled}}{\text{in min}} = \mu\text{g collected}$$

Expected mass collected by dosimeters, μg_d

$$\mu\text{g}_d = \frac{C_E \text{ ng/ml}}{1000} \times t \times \frac{A}{\lambda} \times D_T$$

where:

- t = exposure time in seconds
 A = diffusion path cross-sectional area in $\text{cm}^2 = 9.54$
 λ = diffusion path length in cm = 1.31
 D_T = diffusion coefficient at temperature and pressure of sampling. To convert the experimental diffusion coefficient to the existing sampling conditions:

$$D_T = D_o \left(\frac{T}{273} \right)^{3/2} \left(\frac{760}{P} \right)$$

where:

- D_o = D at 273°K, 760 mm P
 T = sampling temperature
 P = sampling pressure

for a 4 hour exposure, $t = 14,400$ sec and the calculation simplifies to:

$$\mu\text{g}_d = \frac{C_E \text{ ng/ml}}{1000} \times 14400 \times \frac{9.54}{1.31} \times D_T$$

TABLE B-3 (continued)

$$\mu\text{g}_d = 104.9 C_E \text{ ng/ml} \times D_T$$

Time-weighted average concentration equivalent to the mass collected on the dosimeter:

$$\text{ppm} = \mu\text{g}_d - \mu\text{g}_b \times \frac{22400}{\text{MW}} \times \frac{T}{273} \times \frac{760}{P} \times \frac{\lambda}{D_T A t}$$

where μg_b = μg found in the blank

For a 4-hour exposure, the calculation simplifies to :

$$\text{ppm} = \mu\text{g}_d - \mu\text{g}_b \times \frac{0.0186 T}{D_T P}$$

TABLE B-4. EXPOSURE CONDITIONS (October 4, 1978)

Date: 10/4/78
 Duration: 4 hours
 Approximate concentration: 1 ppm
 Ambient atmospheric pressure: 767 mm Hg
 Chamber relative humidity: 51%
 Wet bulb: 63°F (17.2°C) Dry bulb: 75°F (23.9°C)
 Dosimeters exposed: XVI-XX, XXIII-XXVI, XXVIII, XXXI-XXXV
 Impingers exposed: A, B, C
 Impinger solution: 0.1M HCL
 Diffusion run III, hydrazine rate = 7600 ng/min, $D_0 = 0.074 \text{ cm}^2/\text{sec}$

	<u>Begin exposure</u>	<u>End exposure</u>	<u>Average value</u>
Time	9:15 A.M.	1:27 P.M.	
Chamber T	21.7°C	24.2°C	23.0°C
Critical orifices			
A	0.94 lpm	1.02 lpm	0.98 lpm
B	1.04	1.07	1.06
C	0.90	0.94	0.92
Rotameter readings			Actual flow
N ₂	1.0	1.0	1.0 = 0.1 lpm
Dry air	2.5	2.5	2.5 = 3.1
Wet air	2.75	2.75	<u>2.75 = 3.1</u>
Total dilution flow			6.3 lpm

TABLE B-5. TYPICAL EXPOSURE TEST CALCULATION (October 4, 1978)

Concentration delivered to exposure chamber, C_E

$$C_E = \frac{\text{diffusion rate}}{\text{total dilution flow}} = \frac{\text{ng}}{\text{ml}}$$

$$C_E = \frac{7600}{6300} = 1.21 \text{ ng/ml}$$

$$C_E \text{ ppmv} = \frac{C_E \text{ ng/ml} \left(22400 \times \frac{T}{T_o} \times \frac{P_o}{P} \right)}{1000 \times \text{MW}}$$

$$C_E \text{ ppmv} = \frac{1.21 \left(22400 \times \frac{296}{273} \times \frac{760}{767} \right)}{1000 \times 32} = 0.91 \text{ ppmv}$$

Expected mass collected in impingers, μg_I

$$\mu\text{g}_I = \frac{C_E \text{ ng/ml}}{1000} \times \text{flow through impinger} \times \text{time sampled} = \mu\text{g collected}$$

$$\mu\text{g}_I = 0.00121 \times 980 \times 240 = 285 \mu\text{g} \quad \text{impinger A}$$

$$\mu\text{g}_I = 0.00121 \times 1060 \times 240 = 308 \mu\text{g} \quad \text{impinger B}$$

$$\mu\text{g}_I = 0.00121 \times 920 \times 240 = 267 \mu\text{g} \quad \text{impinger C}$$

Expected mass collected by dosimeters, μg_d

$$\mu\text{g}_d = 104.9 C_E \text{ ng/ml} \times D_T$$

$$D_T = 0.074 \left(\frac{296}{273} \right)^{3/2} \left(\frac{760}{767} \right) = 0.083$$

$$\mu\text{g}_d = 104.9 (1.21) (0.083) = .11$$

Time-weighted average concentration equivalent to the mass collected on the dosimeter

$$\text{ppm} = \mu\text{g}_d - \mu\text{g}_b \times \frac{0.0186 T}{D_T P}$$

$$\text{ppm} = 13 \times \frac{0.0186 T}{D_T P}$$

$$\text{ppm} = 13 \times \frac{0.0186 (296)}{0.083 (767)} = 1.1$$