

AD-A077 070

COASTAL ENGINEERING RESEARCH CENTER FORT BELVOIR VA
SAMPLING MACROINVERTEBRATES ON HIGH-ENERGY SAND BEACHES.(U)
SEP 79 A K HURME , R M YANCEY , E J PULLEN
CERC-CETA-79-3

F/G 6/6

UNCLASSIFIED

NL

1 OF 1
AD-
A077070



END
DATE
FILMED
12-79
DDC

AD A 077 070

12

CETA 79-3

Sampling Macroinvertebrates on High-Energy Sand Beaches

LEVEL

by

Arthur K. Hurme, Robert M. Yancey, and Edward J. Pullen

COASTAL ENGINEERING TECHNICAL AID NO. 79-3
SEPTEMBER 1979

DDC
R
NOV 21 1979
E



Approved for public release;
distribution unlimited.

DDC FILE COPY

U.S. ARMY, CORPS OF ENGINEERS COASTAL ENGINEERING RESEARCH CENTER

Kingman Building
Fort Belvoir, Va. 22060

79 11 16 047

Reprint or republication of any of this material shall give appropriate credit to the U.S. Army Coastal Engineering Research Center.

Limited free distribution within the United States of single copies of this publication has been made by this Center. Additional copies are available from:

*National Technical Information Service
ATTN: Operations Division
5285 Port Royal Road
Springfield, Virginia 22161*

Contents of this report are not to be used for advertising, publication, or promotional purposes. Citation of trade names does not constitute an official endorsement or approval of the use of such commercial products.

The findings in this report are not to be construed as an official Department of the Army position unless so designated by other authorized documents.

PREFACE

This report is a guideline suggesting standardized, quantitative methods for sampling benthic communities on high-energy sand beaches. The guideline is intended to help coastal engineers and biologists obtain data for use in evaluating the environmental impacts of coastal engineering projects on sand beaches.

The report was prepared by Arthur K. Hurme, Robert M. Yancey, and Edward J. Pullen of the Coastal Ecology Branch, under the general supervision of R.P. Savage, Chief, Research Division.

Comments on this publication are invited.

Approved for publication in accordance with Public Law 166, 79th Congress, approved 31 July 1945, as supplemented by Public Law 172, 88th Congress, approved 7 November 1963.

Ted E. Bishop

TED E. BISHOP

Colonel, Corps of Engineers
Commander and Director

Accession For	
MIS. GEN. I	<input checked="" type="checkbox"/>
DAC TAB	<input type="checkbox"/>
Unannounced	<input type="checkbox"/>
Justification	
By _____	
Distribution/	
Availability Codes	
Dist	Avail and/or special
A	

CONTENTS

	Page
CONVERSION FACTORS, U.S. CUSTOMARY TO METRIC (SI)	6
I INTRODUCTION	7
II HIGH-ENERGY SAND BEACHES	7
III PLANNING FIELD TRIPS	8
1. Prerequisite Information	8
2. Timing Field Trips	9
3. Field Crew and Equipment	10
IV DESIGN OF SAMPLING PLAN.	10
1. General Guidelines	10
2. Sampling Effectiveness	13
3. Sampling Strategy.	13
4. Distribution of Samples.	16
V SAMPLING METHODS	17
1. Establishing Sampling Transects.	17
2. Sampling the Swash and Surf Zone	18
3. Sampling the Nearshore Zone.	18
IV SAMPLE TREATMENT	22
VII POPULATION ANALYSIS.	23
VIII COST AND MANPOWER ESTIMATES.	24
LITERATURE CITED	25
BIBLIOGRAPHY	26
APPENDIX	
A NOAA CLIMATOLOGICAL INFORMATION SOURCES.	29
B SOURCES OF COASTAL WAVE DATA	32
C GLOSSARY	33
TABLES	
1 Characteristics of high-energy and low-energy beaches	8
2 Material and equipment needed for quantitative sampling of macrofauna on high-energy sand beaches	11
3 Effect of increasing sample size on means per sample and confidence limits of major groups and species.	15

CONTENTS--Continued

FIGURES

	Page
High-energy sand beaches.	7
Effects of increasing number of replications on number and percent of species caught from a population.	14
1	
Species diversity, H' , and evenness, J , values calculated from increasing numbers of replicate samples.	16
2	
Screw anchor.	17
3	
Trenching shovel and sieves used for macrofaunal extraction . . .	19
4	
Typical coring devices.	20
5	
Airlift suction dredge.	21
6	
7	

CONVERSION FACTORS, U.S. CUSTOMARY TO METRIC (SI)
UNITS OF MEASUREMENT

U.S. customary units of measurement used in this report can be converted to metric (SI) units as follows:

Multiply	by	To obtain
inches	25.4	millimeters
	2.54	centimeters
square inches	6.452	square centimeters
cubic inches	16.39	cubic centimeters
feet	30.48	centimeters
	0.3048	meters
square feet	0.0929	square meters
cubic feet	0.0283	cubic meters
yards	0.9144	meters
square yards	0.836	square meters
cubic yards	0.7646	cubic meters
miles	1.6093	kilometers
square miles	259.0	hectares
knots	1.852	kilometers per hour
acres	0.4047	hectares
foot-pounds	1.3558	newton meters
millibars	1.0197×10^{-3}	kilograms per square centimeter
ounces	28.35	grams
pounds	453.6	grams
	0.4536	kilograms
ton, long	1.0160	metric tons
ton, short	0.9072	metric tons
degrees (angle)	0.01745	radians
Fahrenheit degrees	5/9	Celsius degrees or Kelvins ¹

¹To obtain Celsius (C) temperature readings from Fahrenheit (F) readings, use formula: $C = (5/9) (F - 32)$.

To obtain Kelvin (K) readings, use formula: $K = (5/9) (F - 32) + 273.15$.

SAMPLING MACROINVERTEBRATES ON HIGH-ENERGY SAND BEACHES

by
Arthur K. Hurme, Robert M. Yancey, and Edward J. Pullen

I. INTRODUCTION

Open-coast beaches which are continually under the stress of wave action, periodic exposure and submergence by tides, offer habitats for a variety of marine organisms. There are no standardized, quantitative methods for the study of benthic animal communities on high-energy beaches. Therefore, this guideline suggests methods of sampling macroinvertebrates (i.e., those animals equal to or greater than 0.5 millimeter in size) on high-energy sand beaches to obtain data for use in evaluating the environmental impact of coastal engineering projects on those beaches. Sampling techniques were developed from research sponsored by the Coastal Engineering Research Center (CERC) (see Bibliography) and others. (Lack of specific citation does not imply originality.) Procedures for sampling intertidal environments and a detailed explanation of sampling program design and data analysis are provided in Gonor and Kemp (1978). The suggested techniques cannot be used to quantify highly mobile species or sample deep-burrowing forms. Samples may be contaminated by organisms in the overlying water column; however, these organisms can easily be identified and separated from the samples. Only a generalized sampling plan (sample size, number, and placement) is considered in this guideline since a specific plan must be tailored to individual beaches and project objectives.

II. HIGH-ENERGY SAND BEACHES

High-energy sand beaches (Fig. 1) comprise parts of the shore in all coastal regions of the United States and account for the major part of the mid-Atlantic, South Atlantic, gulf, southern California, and Great Lakes shores. These beaches are exposed to strong wave action. The

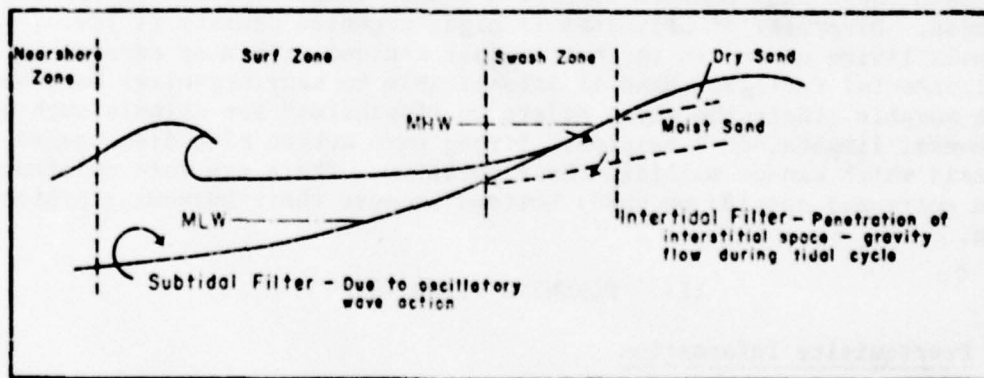

Figure 1. High-energy sand beach (modified from Cox, 1976).

shifting beach sands constantly respond to changes in wind, waves, and currents. Cycles of erosion and deposition are essential features of the sand beach environment. Low wave energy permits the accumulation of fine sediments which fill the interstitial spaces. This cuts off the supply of oxygen and leads to the promotion of a sulfide layer characterized by a black color. A high-energy beach, however, is permeable and its pore spaces are frequently in contact with the air or oxygenated water.

Another characteristic of the high-energy beach is its slope. High-energy beaches tend to have slopes of about 2 to 11 percent; low-energy beaches have slopes of less than 1 percent. Distinguishing characteristics of both types of beaches, as described by Cox (1976), are compared in Table 1.

Table 1. Characteristics of high-energy and low-energy beaches (modified from Cox, 1976).

High-energy beach	Low-energy beach
Steep, about 2 to 11 percent slope	Less steep, usually <1 percent slope
Interstitial water, well oxygenated	Pronounced O ₂ gradient; sulfide layer
Low proportion of particles <250 μm; median diameter (M _d) <250 μm	High proportion of particles <250 μm; M _d <250μm
Well-developed interstitial community; high diversity	Small or nonexistent interstitial community; low diversity
Low carbon content: 70 to 400 μg C/g sediment	High carbon content: 220 to 2,250 μg C/g sediment
High turnover rate with no accumulation of carbon	Lower turnover rate with carbon accumulation

Open-coast sand beaches support a faunal community that is low in biomass. Diversity of organisms is high; organism density is low. Animals living on and in the bottom must contend with many adverse environmental factors. Sand is inhospitable to many organisms because of a movable substratum which offers no "footholds" for animals such as anemones, limpets, or barnacles. Strong wave action also discourages animals which cannot maintain their position. There are more endofaunal than epifaunal species on sandy bottoms because their burrowing protects them.

III. PLANNING FIELD TRIPS

1. Prerequisite Information.

Data on the local geology, weather and sea conditions, and manmade features of the high-energy sand beach to be sampled must be gathered. Grain-size analysis is generally available from coastal engineering

studies. Carbonate content of the sediment may also be available. Common beach features such as cusping, position of foredune and berm, offshore bars, longshore transport, and local geological features such as headlands, offshore islands, stream mouths, freshwater springs, and submarine canyons should be noted. Available water temperature and salinity data should also be analyzed before preparing a sampling plan.

Nearby manmade features (planned or existing) such as seawalls, groins, offshore breakwaters, piers, artificial islands, and sewer outfalls should be considered in planning the location of sampling stations.

2. Timing Field Trips.

Determining when samples can be taken is one of the most important considerations in assuring successful sampling of a high-energy sand beach. When sea conditions are suitable (i.e., waves are low enough to permit sampling) a field crew should be available on short notice to sample before the conditions change. CERC's experience has been that if the waves are of short period (about 6 to 7 seconds) and the beach is steep (> 9 percent), the highest tolerable wave is about 2 to 3 feet (0.6 to 1 meter). Higher waves (4 to 6 feet or 1.2 to 2 meters) may be tolerated if the wave periods are longer (at least 10 to 12 seconds) and the beach is gently sloping (< 9 percent). An experienced field crew can work under much more rigorous conditions than an inexperienced crew. Sampling on the same tidal phase during each trip is recommended.

The best way to plan the sampling is to obtain historic weather records (App. A) and wave records (App. B), and choose periods of relatively calm sea conditions. After the general sampling periods have been defined, short-term (24 hours) wave forecasts can be used to improve the chances of success on field trips.

Data from weather summary sheets, wave gages, and information on the orientation of the coast and offshore bottom contours can be used to determine general wave climate trends. After establishing long-term trends and the general sampling time, actual sampling dates must be selected. The National Weather Service (NWS) information can be used for this purpose. Marine NWS charts summarize the major sources of local weather information in each of 15 coastal areas of the United States (see App. A for chart listing and ordering information). Small-craft navigation charts, often available at marinas and marine supply stores, frequently list local sources of marine weather information (App. A). Since the National Oceanic and Atmospheric Administration (NOAA) Weather Radio System is operational for most coastal areas of the United States, the monitoring of these broadcasts, which report wave conditions at nearby NOAA gages, will help the field crew determine favorable sampling conditions. Monitoring in the field will also alert the crew to changing weather conditions and severe thunderstorm activity. Local wave gage information may be available from the same sources as the historic data (App. B). A reliable observer living or working at or

near the site is valuable. If the area is a beach nourishment site, or if the local Corps of Engineers District has a project near the site, CERC's Littoral Environmental Observations (LEO) program may have been established. LEO observers are excellent contacts to help determine suitable sampling times. However, the field crew will have to make the final determination of acceptable working conditions.

3. Field Crew and Equipment.

Teams of four are most effective. Ideally, persons able to participate throughout the study should be selected. This will save training new people for each sampling trip and field crew performance will improve with experience. Crew members should have flexible schedules to take advantage of favorable weather. All members must be excellent swimmers and at least two must be qualified scuba divers. Equipment needed to quantitatively sample a high-energy beach is listed in Table 2.

IV. DESIGN OF SAMPLING PLAN

1. General Guidelines.

Snedecor and Cochran (1967) identified two major problems confronting an investigator: defining and conducting the sampling, and making correct inferences about the population sampled. The objectives of a valid sampling plan require a reduction of the variance of the parameters of interest due to sampling error. This requires repeated sampling until the samples estimate the actual population parameter within the desired confidence limits. Sampling may be restricted to a few permanent stations within a defined area or may consist of transects and stations. Usually a preliminary set of samples will have to be taken from a particular beach to determine the final sampling plan. Development of a preliminary sampling plan depends on information generated from other studies and the experience of the investigator. (Gonor and Kemp, 1978, provide a compilation of procedures for quantitatively sampling intertidal environments.)

Three major questions must be answered to develop a quantitative sampling plan:

(a) Does the sampling device catch all or most of the organisms found in a given volume of sediment?

(b) How many replicates must be taken to be confident, within certain statistical limits, that the parameter used to describe a population are adequately estimated?

(c) How should the replicates be distributed over the study area?

Table 2. Material and equipment needed for quantitative sampling of macrofauna on high-energy sand beaches.

Material and equipment	Use
Surveying and engineering supplies	
Surveying level or transit and tripod	Surveying sampling location
Surveying rod or equivalent (25-foot collapsible fiberglass)	Surveying sampling location
Surveyor's fiberglass chain or marked Dacron line	Surveying sampling location
Stakes (1- by 18-in standard wooden survey stakes) or pipe	Marking sampling location
Diver supplies	
Standard scuba or skin diving gear	Performing subtidal sampling
Diver's collection "bug" bag of nylon mesh	Transporting several samples simultaneously
Hardware supplies	
Screw anchors, either 30 or 48 in, with installation bar	Marking transect lines
Marked plastic bags with plastic-coated twist-ties	Temporary storage of organisms
Boating supplies	
Polypropylene rope (3/8-in or larger diameter)	Marking transect lines
Floats or plastic jugs	Marking station stakes
Small boat, inflatable raft, or large inner tube with washtub	Transporting samples and equipment
Insulated cooler (picnic type)	Keeps samples cool, retarding decomposition
Hardware or farm supplies.	
0.1-m ² frame and squared trenching shovel	Excavating quadrats
Plug sampler with cover, handles, and top screen	Sampling smaller organisms
Airlift (suction) dredge	Sampling in deeper (>2 m) water
Large sieving frame	Sorting larger organisms

Table 2. Material and equipment needed for quantitative sampling of macrofauna on high-energy sand beaches.--Continued

Material and equipment	Use
Scientific supplies	
Chemicals	
Formalin (commercial solution of formaldehyde)	Temporary storage of animals (mix with seawater)
Magnesium chloride ($MgCl_2$) or Epsom salts ($MgSO_4 \cdot 7H_2O$)	Relax organisms for identification
Rose bengal (biological stain)	Ease in sorting samples
Marble chips or borax or equivalent buffer	Buffering seawater and formalin solution
Glycerin	Keep materials from becoming brittle
Alcohol (denatured ethyl or isopropyl); drugstore rubbing alcohol may be used without dilution	Permanent storage of samples
Materials	
Screens (0.5- to 1.0- mm mesh)	Sample separation of organisms from sediment
Standard series of soil sieves, smallest mesh to be U.S. Standard Mesh Size #35 or #18 (0.5 or 1.00 mm)	Sample separation of organisms from sediment
Erlenmeyer flasks (4 liters)	Sample separation of organisms from sediment
Petri dishes, finger bowls, shallow enamel pans	Sorting animals
Sample jars and caps	Storage of animals
Museum labels or high-grade rag-bond paper (not gummed)	Labeling
Pen and India ink	Labeling
Binocular dissecting scope (X10, X20, and X40 magnifications)	Identification of animals
Forceps and dissecting needles	Aid in specimen identification
Portable temperature conductivity - salinity meter with cable and probes	Measure temperature and salinity

2. Sampling Effectiveness.

Three sampling techniques are recommended: coring, trenching, and suction dredging. The area sampled is a function of the number and size of samples taken. The depth of the samples and the sieve mesh must be consistent. To be comparable to the greatest number of other studies, samples should be taken to a depth of 8 inches (20 centimeters) and sieved through a 0.5-millimeter sieve. If time and cost constraints require, the depth of sampling may be reduced to 4 inches (10 centimeters) and the sieve increased to 1.0-millimeter mesh rather than reduce the number of sampling stations.

3. Sampling Strategy.

Number of Sample Replicates. Three commonly used parameters to describe the benthic infauna are: the number of species, the total number of individuals, and the number of individuals per species. The number of samples initially taken to determine the number of replicate samples needed is always greater than the number that would be taken during the field survey at any one station. Although this sampling need not be strictly random, individual samples should be chosen at random from the combined group for the determination of the number of replicates needed.

(1) Number of Species. Species are recorded in two ways: the total number of species collected in all samples and the average number of species per sample. If a species cannot be identified in the field or laboratory, assign the unknown species a code number and proceed with the identification.

The figures and table used in the following sections are from a report by Oliver and Slattery (1976), as an example of one approach to developing a sampling strategy. Figure 2 is an example of an accumulation rate of new species as the area sampled is increased (Oliver and Slattery, 1976). The replicates are averages of three random samples of twenty-eight 0.022-square yard (0.018 square meter) samples. Considering all 28 samples as 100 percent of the sampling area, 16 samples represent 57 percent of the area and contain 92 percent of the species, 8 samples represent 30 percent of the area and contain 76 percent of the species, and 4 samples represent 14 percent of the area and contain 57 percent of the species.

To examine the relationship between the number of replicates and the number of species per sample, replicates should be drawn at random and the means of confidence limits computed for progressively larger sample sizes. The average number of species per sample (Table 3) changed little with increasing sample size above about eight replicates. The confidence limits will continue to narrow as the number of replicates increase. The number of replicates taken will depend on the sampling objectives and the risk involved with making the wrong decision.

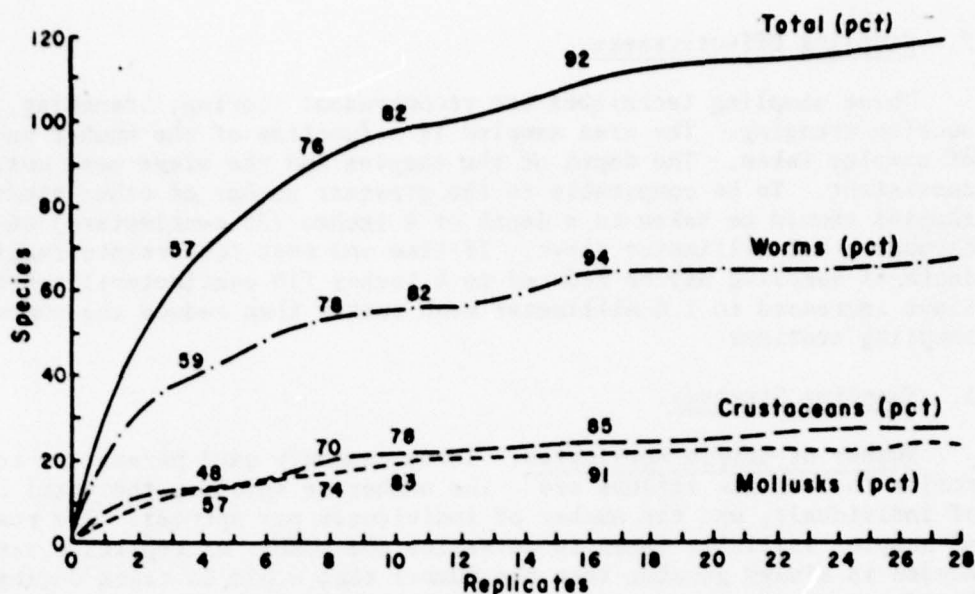

Figure 2. Effects of increasing number of replications on number and percent of species caught from a population (Oliver and Slattery, 1976).

(2) Total Number of Individuals and Number of Individuals Per Species. Animals are usually recorded in two ways: total number of individuals and number of individuals per taxonomic group or species. In Table 3, the 19 species found by Oliver and Slattery (1976) have been ranked and three main groups delineated on the basis of abundance. Means per sample and their 95-percent confidence limits are listed for the four sample sizes. The 19 species are distinguished by the following characteristics: (a) They contain 87 percent of the total number of individuals of all species collected (by group--90 percent mollusks, 90 percent crustaceans, and 87 percent worms); (b) variance-to-mean ratios are greater than 1 in all cases and less than 7 with the exception of *Prionospio cirrifera* and *Mediomastus californiensis*; and (c) the mean abundance per sample is greater than 1.5 (Oliver and Slattery, 1976). The lower cutoff point in the ranking is somewhat arbitrary, since abundance decreases gradually and there is no clear-cut distinction between the last species included and the first one excluded. Dominance of a few species can be seen by the fact that 90 percent of the individuals are contained in 4 of the 19 species. For most of the species, the confidence limits decrease sharply from 4 to 8 replicates and continue to decrease to 28 replicates. Exceptions are some of the species with the highest variance-to-mean ratios.

Table 3 also shows changes in the estimate of the total number of individuals per sample and individuals of major groups per sample.

Table 3. Effect of increasing sample size on means per sample and confidence limits of major groups and species (Oliver and Slatatory, 1976).

Group-Species (No. per core)	No. of replicates							
	4		8		16		28	
	\bar{x}	CL ²	\bar{x}	CL	\bar{x}	CL	\bar{x}	CL
Species	32.3	4.2	33.6	4.4	33.8	3.6	33.8	2.1
Individuals	193.5	44.8	190.3	41.4	195.8	22.5	197.3	16.4
Individuals:								
Worms	99.3	18.8	91.6	18.3	96.3	11.9	100.3	12.0
Crustaceans	39.5	34.0	35.1	6.1	36.7	8.4	34.3	3.4
Mollusks	54.8	33.3	63.5	9.9	62.9	10.9	62.8	8.0
<i>Tellina medesta</i>	44.3	32.1	52.8	20.1	49.7	10.0	51.3	7.4
<i>Magelona sacculata</i>	33.8	14.3	31.8	7.3	34.4	6.5	36.3	6.0
<i>Paraphoxus daboilus</i>	21.0	13.7	17.1	6.1	15.6	4.3	16.5	3.0
<i>Prionospio pygmaeus</i>	18.5	19.7	16.0	7.9	14.5	3.9	16.0	3.3
<i>Nothria elegans</i>	7.5	6.7	5.8	3.4	5.9	2.1	6.1	1.4
<i>Lumbrineris luti</i>	6.8	6.9	6.6	2.4	5.3	1.7	5.9	1.3
<i>Prionospio cirrifera</i>	1.8	2.4	1.4	1.4	3.6	2.6	5.6	3.5
<i>Siliqua patula</i>	5.0	4.7	5.5	2.9	5.6	1.9	5.1	1.2
<i>Mediomastus californiensis</i>	8.5	3.8	5.4	2.6	4.4	3.1	4.3	1.9
<i>Hemilamprops californica</i>	4.5	13.2	3.0	4.8	5.6	3.7	3.7	2.2
<i>Haploscoloplos elongatus</i>	2.0	2.9	2.1	1.2	2.9	1.2	3.0	.8
<i>Euphilomedes oblonga</i>	4.3	2.4	4.0	1.5	3.3	1.0	2.6	.8
<i>Spiaphanes missionensis</i>	2.3	3.5	1.8	1.3	2.2	.8	2.3	.6
<i>Pinnixa franciscana</i>	0	-	.1	.3	1.5	2.5	2.3	2.0
<i>Synchelidium</i> spp.	4.3	9.0	2.3	3.6	2.4	1.8	2.2	1.1
<i>Armandia bioculata</i>	.8	1.5	1.3	1.7	1.5	1.1	2.0	1.1
<i>Nephtys cornuta</i>	2.0	2.5	2.3	1.3	1.9	.9	1.9	.5
<i>Chaetozone setosa</i>	3.0	3.5	2.3	1.5	2.1	.9	1.6	.6
<i>Tellina meropsis</i>	1.3	2.0	1.3	1.0	1.4	.7	1.5	.5

\bar{x} = mean

²CL = 95-pct confidence limits

(3) Number of Sample Replications. In choosing the number of replicates to take at each station, the practical limitations of time and resources, the nature of the research objectives, and the results of the preliminary analysis should also be considered. In Oliver and Slattery (1976), eight replicates contained 87 percent of the total number of individuals. The confidence limits (Table 3) indicate the accuracy of the abundance estimates with the various numbers of replicate samples. Eight samples contained 76 percent of the total number of species in the 28 samples and additional replicates added new species at a much slower rate (Fig. 2). Also, diversity, H' , and evenness, J , values, commonly used for population analysis (Sec. VII), appear to stabilize between four and eight replicate samples (Fig. 3). Therefore, eight appears to be the optimum number of replicates to estimate the number of species based on the additional cost and manpower that would be required to increase the replications (see Sec. VIII).

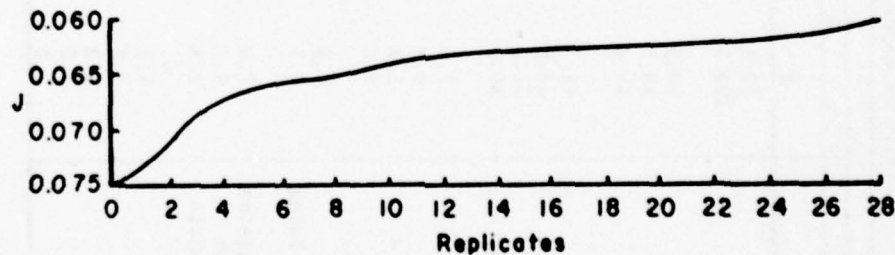
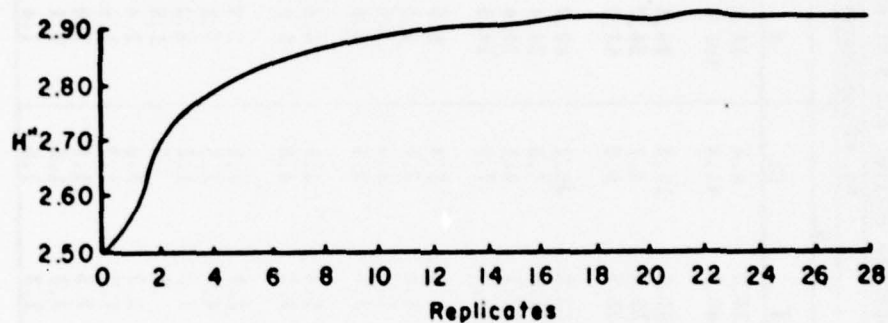

Figure 3. Species diversity, H' , and evenness, J , values calculated from increasing numbers of replicate samples (Oliver and Slattery, 1976).

4. Distribution of Samples.

The detailed patterns of distribution of the species sampled are not examined in this report. However, to construct a quantitative

sampling plan, it is necessary to have some measure of the gross "patchiness" of the populations. Patchiness refers to the aggregation or clumped distribution of individuals in which distribution is not random and the variance is significantly greater than the mean value. Sampling can be stratified by locating stations at different depths, but without further preliminary sampling it is not known whether the magnitude of spatial variation of the endofauna warrants the further stratification of sampling within a depth contour.

To determine the gross patchiness of the endofauna, sets of replicate samples should be taken randomly within depths from progressively larger areas. If any of the major parameters change significantly from one depth to the next, it is necessary to adjust the sampling plan (e.g., stratify) to produce a more reliable estimate of the population.

V. SAMPLING METHODS

1. Establishing Sampling Transects.

After the sampling methods and number of replicate samples needed are determined, transects can be established and marked by inserting stakes or screw anchors at the upper limit of the transects (Fig. 4).

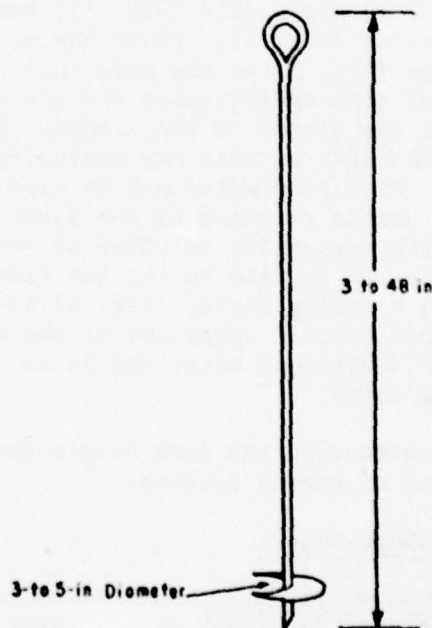

Figure 4. Screw anchor.

Install the screw anchor by inserting a rod through the eye and turning it into the bottom. Determine the location of each sampling station along the transect with a tape or marked line, and mark each with a screw anchor. Thread a 3/8-inch polypropylene line through the eyes of the screw anchors along the transect to provide a lifeline and to help keep the divers on station. A float attached to another line through the eye of the seaward screw anchor will provide a visual aid to help keep the screw on station. Place two range posts on the upper beach to assure that the divers stay on the transect, as longshore currents will tend to drift them down current. After the transect has been established survey the elevation of each of the sampling stations using the level, tripod, and surveying rod.

2. Sampling the Swash and Surf Zone.

The swash zone and the upper surf zone usually include the intertidal and the near subtidal areas. (Generally speaking, if you can stand up and breathe without scuba, you're in this zone.) This zone can be further subdivided into two areas based on whether the area is covered with water or is not usually covered with water, except for occasional swash (Fig. 1).

If the area is not covered with water, sample the larger organisms by excavating 0.12-square yard (0.1 square meter) quadrats with a trenching shovel to a depth of at least 4 inches (10 centimeters), however, 8 inches (20 centimeters) is preferable (Fig. 5); sample the smaller organisms with a coring device (Fig. 6). Place the excavated material directly in a sieve box (Fig. 5) or the core in a standard sieve. Place the sieve in an area of nonbreaking waves and sieve the organisms by allowing water through the bottom of the screen. Do not dip and pour water directly into the sieve as this may contaminate the sample with animals in the water. Presieved water may be used to wash the sample. Place the part of the sample retained by the sieve in a labeled plastic bag or a sample jar with preserving solution as described in Section VI. This sampling technique can be used to the low tide line by following an ebbing tide. However, a coring device (Fig. 6) is the only effective way to quantitatively sample benthic organisms if the sampling station is covered with 2 feet of churned-up water and is in or immediately adjacent to an area of breaking waves.

Directions for transferring the core sample from the bottom are given below in the discussion of coring devices.

3. Sampling the Nearshore Zone.

a. Airlift Dredge and Scuba. The nearshore zone (Fig. 1) can be sampled using an airlift (suction) dredge (Fig. 7) and scuba. The water must be 6 or more feet (2 or more meters) deep for an airlift dredge to work efficiently.

The dredge must be calibrated before use to collect a known volume of sediment at a specific depth and air pressure. Calibrate by removing the

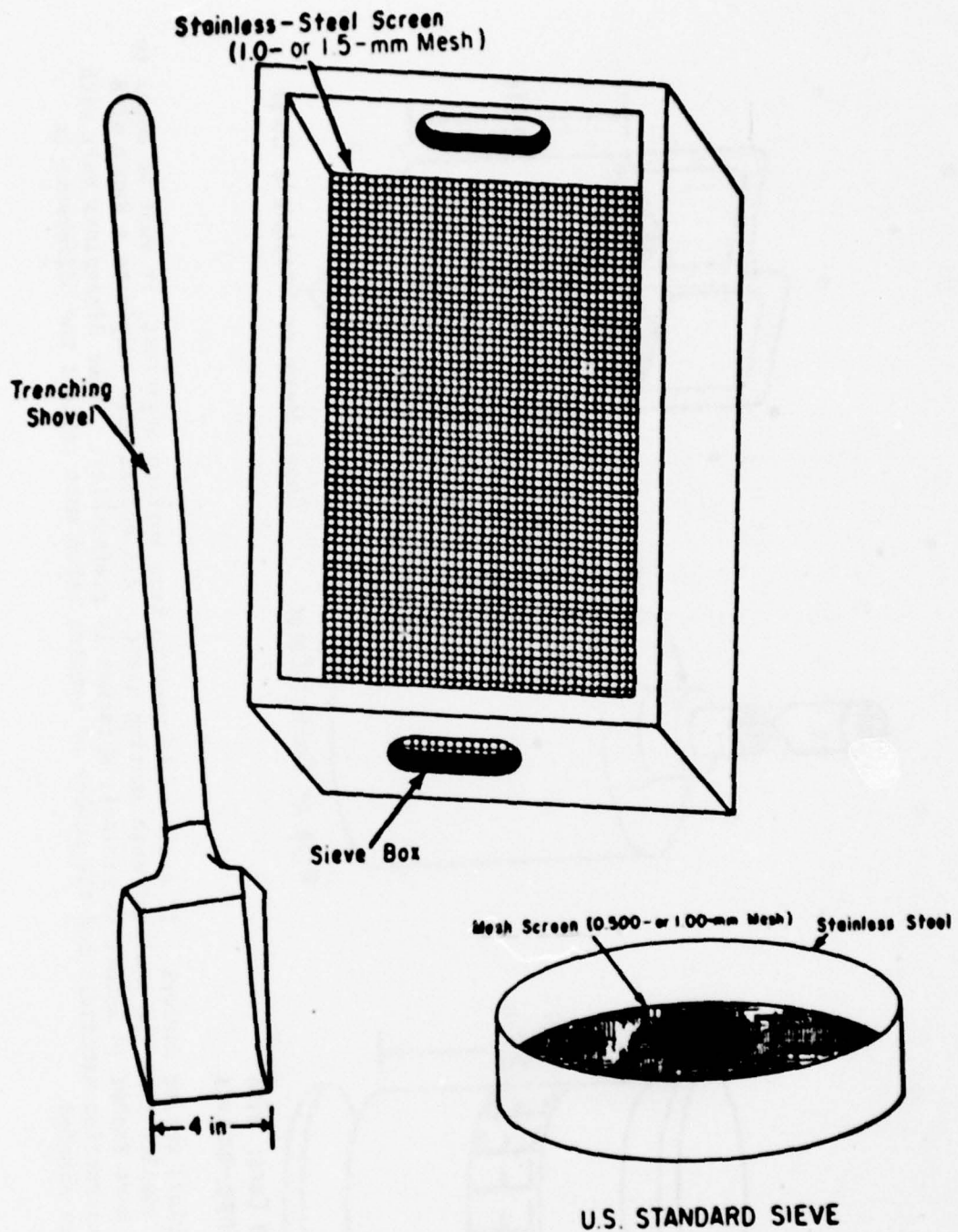
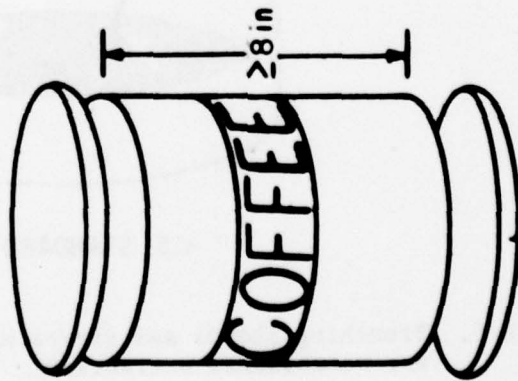
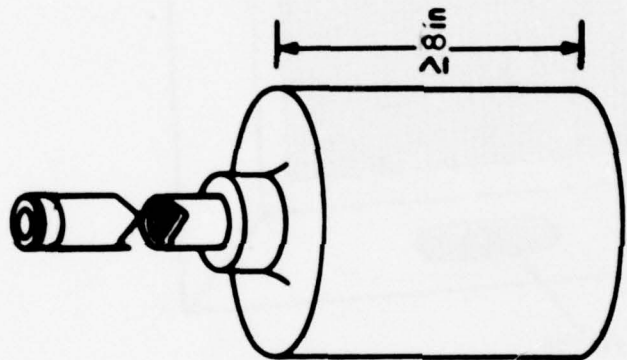

Figure 5. Trenching shovel and sieves used for macrofaunal extraction.



Coffee Can Corer With
Plastic Snap-on Lids



Pipe or Conduit Corer

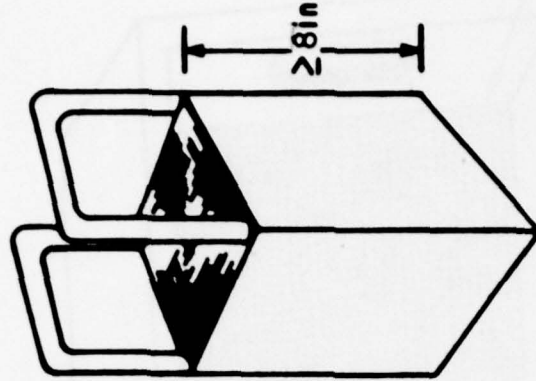

Sheet Metal or Steelplate Corer

Figure 6. Typical coring devices. If a screen is used to trap surface organisms, it must be equal to or smaller than the smallest mesh sorting sieve. All corers must sample to a depth of 8 or more inches (4 inches is minimal; 8 inches is preferable). Other dimensions vary with construction materials and the number of samples taken must reflect the difference in area sampled.

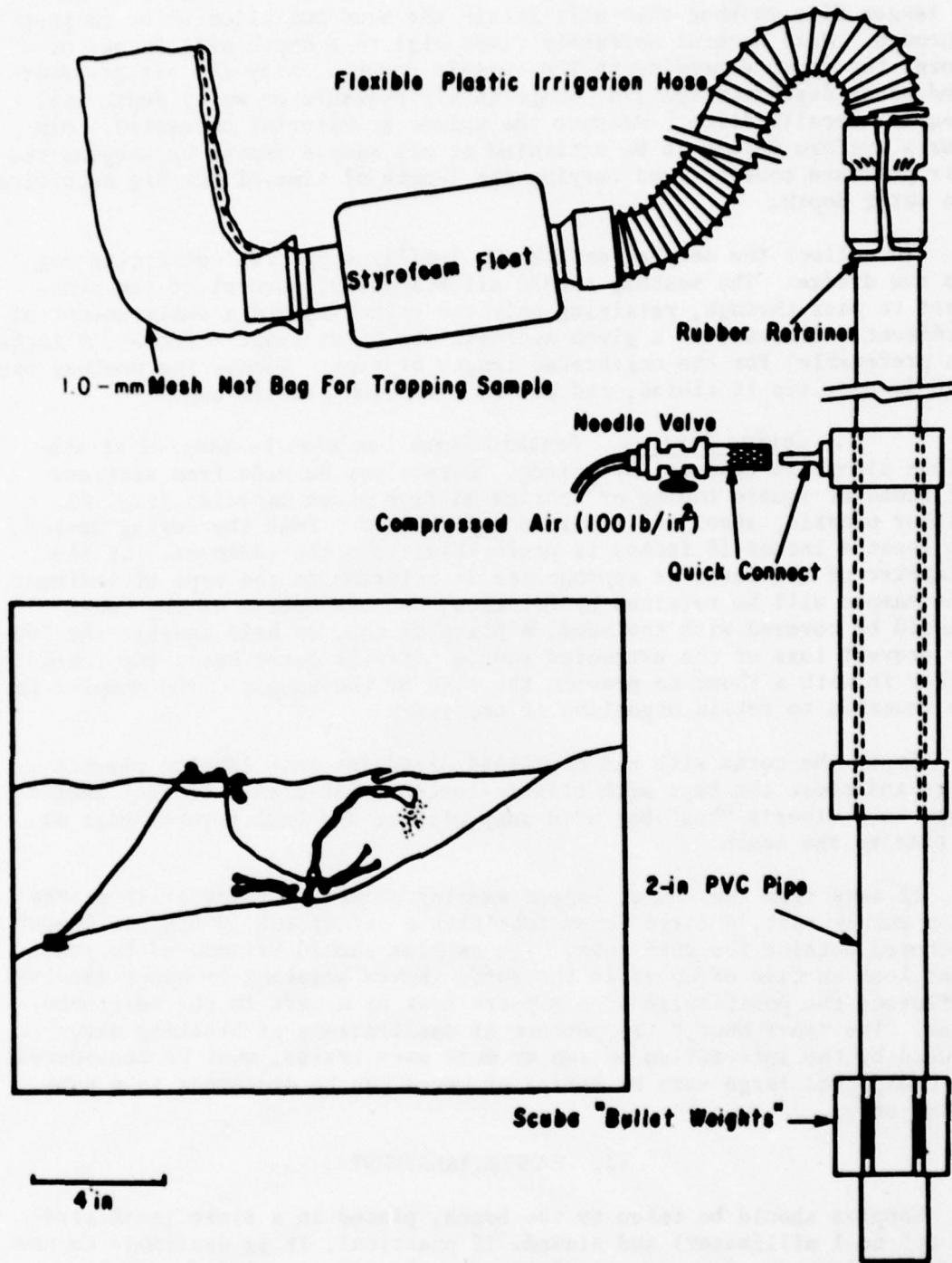

Figure 7. Airlift suction dredge (modified from Cox, 1976).

1-millimeter mesh collecting bag from the dredge and replacing it with a larger fine meshbag that will retain the sand but allow water to pass through. Make several uniformly timed digs to a depth of 4 inches or more, the depth depending on the animals sought. Keep the air pressure and water depth constant; a change in air pressure or water depth will require recalibration. Measure the volume or material excavated. Aim for a uniform volume to be excavated at all sample depths by keeping the air pressure constant and varying the length of time of the dig according to water depth.

To collect the sample, attach the 1-millimeter mesh collecting bag to the dredge. The meshbag should allow about 95 percent of the sediment to pass through, retaining only the organisms and a small amount of sediment. Excavate to a given sediment depth (at least 4 inches, 8 inches is preferable) for the calibrated length of time. Remove the meshbag from the dredge, tie it closed, and put in a labeled plastic bag.

b. Coring Devices. Benthic fauna can also be sampled at stations along the transect by coring. Corers may be made from sections of round or square tubing or fabricated from sheet material (Fig. 6). Either plastic, steel, or aluminum may be used. Push the coring device at least 4 inches (8 inches is preferable) into the sediment. If the diameter of the corer is appropriate in relation to the type of sediment, the sample will be retained by friction, but the bottom of the corer should be covered with the hand, a plate or cap, or held against the body to prevent loss of the extracted sample. If the corer has a top venthole, cover it with a thumb to prevent the loss of the sample. The sampler may be inverted to retain organisms if necessary.

Empty the cores with the contained organisms into labeled plastic bags and close the bags with plastic-coated twist-ties. Collect sample bags in a diver's "bug" bag with snap closure and haul several bags at a time to the beach.

If away from the shore, bagged samples should be temporarily stored in a rubber raft, a large inner tube with a net or tub insert, or a boat anchored outside the surf zone. The samples should be secured to prevent loss in case of upset in the surf. Waves breaking on outer sandbars influence the positioning of a support boat or a raft in the nearshore zone. The "surf beat," the pattern of oscillations of breaking waves caused by the interaction of two or more wave trains, must be considered. An unexpected large wave or series of waves can be dangerous to a sampling crew.

VI. SAMPLE TREATMENT

Samples should be taken to the beach, placed in a sieve (mesh size of 0.5 to 1 millimeter) and sieved. If practical, it is desirable to use a 0.5-millimeter sieve, particularly for the core samples for small organisms; 1.0 millimeter is generally more cost-effective. If a large number of samples are taken in coarse sediments, use a larger mesh sieve

(1.5 or 2.0 millimeters) as a preliminary screening. The material left after sieving a sample should be preserved in 10-percent formalin-seawater solution and buffered with marble chips or a borax solution (1.5 grams per liter). Samples should be processed as completely in the field to ensure that the specimens will be in the best possible condition. If samples cannot be adequately processed in the field, place them in ice coolers and return the samples to a laboratory for immediate preliminary processing. During transport, samples should be kept cool (1° to 4° Celsius) to retard decomposition.

In the laboratory the preserved samples should be rinsed in freshwater or 70-percent ethanol, organisms stained with rose bengal dye, and sorted into major taxonomic groups. Before preserving live animals for identification, immerse in 6-percent magnesium chloride ($MgCl_2$) or Epsom salts ($MgSO_4 \cdot 7H_2O$) in seawater to relax them. This procedure is usually not practical in the field. Identify organisms to the lowest practical taxonomic group, then count and measure by groups. Identification of animals to genus or species may require either a binocular dissecting scope or a compound microscope depending on the size of the organisms and the desired level of identification.

The processed samples should then be transferred to specimen jars or vials containing 70-percent ethanol with 5-percent glycerin. It is important to add glycerin to prevent the organisms from becoming brittle. A waterproof paper label should be placed inside each jar to identify the specimens. Each label should include the following information printed in India ink.

- (1) Accession number (specimens should be logged in a notebook).
- (2) Lowest taxonomic identification.
- (3) Location: State, county, local direction and distance from landmarks (post office, bench mark, range and section, or island and peninsulas).
- (4) Sampling station number.
- (5) Date: Spell name of month or use Roman numerals.
- (6) Collector's name.
- (7) Identifier's name.

VII. POPULATION ANALYSIS

Several commonly used statistics are included in this report for general information (see App. C for formulas). The Shannon-Weaver formula can be used as the measure of species diversity, H' (Pielou, 1966) and J as a measure of evenness of species abundance (Pielou, 1969). These indices should be used with caution; however, their use in a strictly relative sense is justified.

The Kruskal-Wallis and Mann-Whitney tests can be used to determine if the populations of different areas are the same. Elliott (1971) and Sokal and Rohlf (1969) give detailed explanations of these tests.

Similarity indices and coefficients are becoming popular as a numerical method for classifying many species populations. Over 25 indices and coefficients exist; therefore, care must be exercised in choosing which to use and in interpreting the results. Pielou (1977) discusses the general literature on their use and presents four of the more commonly used methods. These indices and coefficients have no comparative statistical basis, but do give some indication of the similarity of samples.

VIII. COST AND MANPOWER ESTIMATES

One set of samples, using a minimum number of personnel, is estimated at \$3,000 to \$6,000 (1977 prices). A set is assumed to consist of six stations (three intertidal and three subtidal) at each of three transects. The cost varies with the number of samples taken per station, frequency of sampling (seasonal, etc.), and the surf and wave conditions.

The minimum manpower required to obtain a set of samples and identify the animals is: A four-man field crew (two qualified scuba divers and two excellent swimmers); one trained laboratory technician (invertebrate specialist); and one consultant to identify rare animals or difficult groups of animals.

The time required to analyze benthic samples varies with the level of identification for the species collected. Generally, at least 3 hours is required in the laboratory for each hour in the field. Therefore, the analysis may require the greater part of the budget.

LITERATURE CITED

- COX, J.L., "Sampling Variation in Sand Beach Littoral and Nearshore Meiofauna and Macrofauna," TP 76-14, U.S. Army, Corps of Engineers, Coastal Engineering Research Center, Fort Belvoir, Va., Sept. 1976.
- EDGE, B.C., SPERLING, P.A., and MAGOON, O.T., "Compendium of Coastal Wave Data in North America," *Ports '77, Fourth Annual Symposium of the Waterway, Port, Coastal and Ocean Division*, American Society of Civil Engineers, Vol. II, Mar. 1977, pp. 187-217.
- ELLIOTT, J.M., *Some Methods for the Statistical Analysis of Samples of Benthic Invertebrates*, Scientific Publication No. 25, Freshwater Biological Association, The Ferry House, Ambleside, Cumbria, Great Britain, United Kingdom, 1971.
- GONOR, J.J., and KEMP, P.F., "Procedures for Quantitative Ecological Assessments in Intertidal Environments," EPA-600/3-78-087, Corvallis Environmental Research Laboratory, U.S. Environmental Protection Agency, Corvallis, Oreg., Sept. 1978.
- OLIVER, J.S., and SLATTERY, P.N., "Effects of Dredging and Disposal on Some Benthos at Monterey Bay, California," TP 76-15, U.S. Army, Corps of Engineers, Coastal Engineering Research Center, Fort Belvoir, Va., Oct. 1976.
- PIELOU, E.C., "Shannon's Formula as a Measure of Specific Diversity: Its Use and Misuse," *American Naturalist*, Vol. 100, 1966, pp. 463-465.
- PIELOU, E.C., *An Introduction to Mathematical Ecology*, John Wiley and Sons, New York, 1969.
- PIELOU, E.C., *Mathematical Ecology*, John Wiley and Sons, New York, 1977.
- SNEDECOR, G.W., and COCHRAN, W.G., *Statistical Methods*, 6th ed., Iowa State University Press, Ames, Iowa, 1967.
- SOKAL, R.R., and ROHLF, F.J., *Biometry: The Principles and Practice of Statistics in Biological Research*, Freeman, San Francisco, Calif., 1969.

BIBLIOGRAPHY OF CERC-SPONSORED RESEARCH
ON SAMPLING MACROINVERTEBRATES ON HIGH-ENERGY
SAND BEACHES AND THE NEARSHORE ZONE

- COURTENAY, W.R., Jr., et al., "Ecological Monitoring of Beach Erosion Control Projects, Broward County, Florida, and Adjacent Areas," TM-41, U.S. Army, Corps of Engineers, Coastal Engineering Research Center, Fort Belvoir, Va., Feb. 1974, NTIS AD No. 778 733.
- COX, J.L., "Sampling Variation in Sand Beach Littoral and Nearshore Meiofauna and Macrofauna," TP 76-14, U.S. Army, Corps of Engineers, Coastal Engineering Research Center, Fort Belvoir, Va., Sept. 1976, NTIS AD No. A032 115.
- MATTA, J.F., "Beach Fauna Study of the CERC Field Research Facility, Duck, North Carolina," MR 77-6, U.S. Army, Corps of Engineers, Coastal Engineering Research Center, Fort Belvoir, Va., Apr. 1977, NTIS AD No. A040 573.
- NYBAKKEN, J., and STEPHENSON, M., "Effects of Engineering Activities on the Ecology of Pismo Clams," MP 8-75, U.S. Army, Corps of Engineers, Coastal Engineering Research Center, Fort Belvoir, Va., Sept. 1975, NTIS AD No. A016 948.
- OLIVER, J.S., and SLATTERY, P.N., "Effects of Dredging and Disposal on Some Benthos at Monterey Bay, California," TP 76-15, U.S. Army, Corps of Engineers, Coastal Engineering Research Center, Fort Belvoir, Va., Oct. 1976, NTIS AD No. A032 684.
- PARR, T., DIENER, D., and LACY, S., "Effects of Beach Replenishment on the Nearshore Sand Fauna at Imperial Beach, California," MR 78-4, U.S. Army, Corps of Engineers, Coastal Engineering Research Center, Fort Belvoir, Va., Dec., 1978, NTIS AD No. A067 308.
- SALOMAN, C.H., "Physical, Chemical, and Biological Characteristics of Nearshore Zone of Sandy Key, Florida, Prior to Beach Restoration," Final Report, National Marine Fisheries Service, Panama City, Fla., 1974.
- SALOMAN, C.H., "A Selected Bibliography of the Nearshore Environment: Florida West Coast," MP 5-75, U.S. Army, Corps of Engineers, Coastal Engineering Research Center, Fort Belvoir, Va., Apr. 1975, NTIS AD No. A012 854.

SALOMAN, C.H., "The Benthic Fauna and Sediments of the Nearshore Zone off Panama City Beach, Florida," MR 76-10, U.S. Army, Corps of Engineers, Coastal Engineering Research Center, Fort Belvoir, Va., Aug. 1976, NTIS AD No. A031 992.

THOMPSON, J.R., "Ecological Effects of Offshore Dredging and Beach Nourishment: A Review," MP 1-73, U.S. Army, Corps of Engineers, Coastal Engineering Research Center, Washington, D.C., Jan. 1973, NTIS AD No. 756 366.

NOTE--Annotations and instructions for ordering these reports are contained in: PULLEN, E.J., et al., "An Annotated Bibliography of CERC Coastal Ecology Research," MR 78-2, U.S. Army, Corps of Engineers, Coastal Engineering Research Center, Fort Belvoir, Va., May 1978.

APPENDIX A

NOAA CLIMATOLOGICAL INFORMATION SOURCES

1. Sources for current conditions to determine specific favorable sampling days.

a. Marine Weather Services Charts:

- MSC-1 Eastport, Maine, to Montauk Point, New York
- MSC-2 Montauk Point, New York, to Manasquan, New Jersey
- MSC-3 Manasquan, New Jersey, to Cape Hatteras, North Carolina
- MSC-4 Cape Hatteras, North Carolina, to Savannah, Georgia
- MSC-5 Savannah, Georgia, to Apalachicola, Florida
- MSC-6 Apalachicola, Florida, to Morgan City, Louisiana
- MSC-7 Morgan City, Louisiana, to Brownsville, Texas
- MSC-8 Mexican Border to Point Conception, California
- MSC-9 Point Conception to Point St. George, California
- MSC-10 Point St. George, California, to Canadian Border
- MSC-11 Great Lakes: Michigan and Superior
- MSC-12 Great Lakes: Huron, Erie, and Ontario
- MSC-13 Hawaiian Waters
- MSC-14 Puerto Rico and Virgin Islands
- MSC-15 Alaskan Waters

These charts are available at \$1.00 each from:

National Ocean Survey
Distribution Division (C44)
Riverdale, Md. 20840
Telephone: 301-443-8005

b. Navigational Charts. Navigational charts are also available at the above address; telephone: 301-436-6990. A wide variety of charts is available and a catalog should be requested for the area of interest as follows:

NAUTICAL CHART CATALOG 1

Atlantic and Gulf Coasts (Including Puerto Rico and the Virgin Islands)

NAUTICAL CHART CATALOG 2

Pacific Coast (Including Hawaii, Guam and Samoa Islands)

NAUTICAL CHART CATALOG 3

Alaska (Including the Aleutian Islands)

NAUTICAL CHART CATALOG 4

Great Lakes (and Adjacent Waterways)

Nautical Chart Catalogs are available free and give the prices and ordering information for navigational charts and numerous other useful publications, including Tide Tables and Tidal Currents. The small-craft charts often list many of the same weather information sources as the Marine Weather Service (NWS) charts. Navigational charts are also frequently available at local marinas and marine supply stores.

c. NOAA Weather Radio. Use of this service is highly recommended. This service consists of continuous, around-the-clock broadcasts of 4- to 6-minute taped weather messages. The reports are updated every 2 to 3 hours or more frequently if necessary, and are broadcast on one of three high-band FM frequencies - 162.40, 162.475, or 162.55 megahertz. Several different receivers are available and the manufacturers usually provide literature on the system. If more information is required write:

National Weather Service (Attn: W112X1)
National Oceanic and Atmospheric Administration (NOAA)
Silver Spring, Md. 20910

d. Direct Contact with National Weather Service. Listed in telephone directories of major cities under: U.S. Government; Commerce, Department of; National Oceanic and Atmospheric Administration; National Weather Service.

2. Sources for Historic Data for Planning and Report Writing.

The National Climatic Center (NCC) collects, processes, and summarizes weather records for the United States and many parts of the world. The information is published in many forms by NCC and by the U.S. Government Printing Office (GPO). Two publications are particularly useful:

(a) Local Climatological Data.

A monthly summary sheet of weather information for each of over 300 government-operated weather stations. A yearly summary sheet is also available. This may be ordered from NCC. An annual subscription is \$3.30.

(b) Daily Weather Maps.

Weekly charts for the United States, southern Canada, and northern Mexico. Each set contains seven pages of charts, one for each day, with charts on a page depicting:

- (1) Surface weather conditions
- (2) 500-millibar pressure contours
- (3) Highest and lowest temperatures
- (4) Precipitation areas and amounts

This publication is available from GPO. An annual subscription is \$30.00.

Many other publications are available from NCC and GPO. Back issues for recent years are usually available from NCC. A complete listing of publications may be found in "Selective Guide to Climatic Data Sources" currently under preparation by NCC and to be available in 1980 (contact NCC for price). The NWS may provide data and publications without charge to Federal, State, and local agencies and contractors for official use or to some educational institutions using the information in the public interest. The addresses of NCC and GPO are:

National Climatic Center
Federal Building
Asheville, N.C. 28801

Public Documents Department
U.S. Government Printing Office
Washington, D.C. 20402

APPENDIX B

SOURCES OF COASTAL WAVE DATA (modified from Edge, Sperling, and Magoon, 1977)

1. U.S. Government:

Department of the Army
Coastal Engineering Research Center
Coastal Oceanography Branch
Kingman Building
Fort Belvoir, VA 22060

National Oceanographic Data Center
Oceanographic Services Branch, DF61
NOAA/EDS/NODC
Washington, DC 20235
(This Center is also a major depository
of coastal wave data for many of the
recording institutions.)

National Oceanic and Atmospheric Admin-
istration
U.S. Lake Survey Center
Rockville, MD 20852

U.S. Naval Postgraduate School
Monterey, CA 93940

Florida State University
Geology Department
Car 104
Tallahassee, FL 32306

Florida Ocean Sciences Institute
1605 S.E. 3d Court
Deerfield Beach, FL 33441

State University College at Fredonia
Chairman, Department of Geology
Haughton Hall, Room 106
Fredonia, NY 14063

University of Michigan
Great Lakes Research Division
1061 North University Building
Ann Arbor, MI 48104

Old Dominion University
Institute of Oceanography
Norfolk, VA 23508

Northeastern University
Department of Earth Sciences
Greenleaf Street
Boston, MA 02115

Purdue University
Great Lakes Coastal Research Laboratory
Department of Geosciences
Lafayette, IN 47907

Scripps Institute of Oceanography
Box 1529
La Jolla, CA 92093

University of South Carolina
Department of Geology
Columbia, SC 29208

Stanford University
Center for Radar Astronomy
Palo Alto, CA 94305

West Virginia University
Department of Geology and Geography
Morgantown, WV 26506

University of Wisconsin - Milwaukee
Department of Geological Sciences
Milwaukee, WI 53201

2. Private Companies:

Chevron Oil Field Research Company
La Habra Laboratory
La Habra, CA 90631

Commonwealth Edison Company
Director of Environmental Affairs
Post Office Box 767
Chicago, IL 60690

EG&G Environmental Consultants
151 Bear Hill Road
Waltham, MA 02154

Shell Development Company
P.O. Box 481
Houston, TX 77001

3. Universities and Institutes:

Clemson University
Department of Civil Engineering
Lowry Hall
Clemson, SC 29631

University of Delaware
Geology Department
Newark, DE 19711

APPENDIX C

GLOSSARY

- benthic--Pertaining to the subaquatic bottom.
- benthos--A collective term describing: (1) Bottom organisms attached or resting on or in the bottom. (2) Community of animals living in or on the bottom.
- berm--A nearby horizontal part of the beach or backshore formed by the deposit of material by wave action.
- biomass--The amount of living material in a unit area for a unit of time. Also, standing crop, standing stock, live weight, dried weight.
- community--An assortment of animals and plants of several different species that are found in a certain environment such as rocky outer coast or a muddy bay bottom.
- core--A square or circular plug taken from the bottom by a hollow round or square tube.
- confidence limits--A measure of reliability of the estimated parameter. The limits that probably will not be exceeded at a given level of probability are the confidence limits.
- cusping--The formation of a series of low mounds of beach material separated by crescent-shaped troughs spaced at more or less regular intervals along the beach face.
- data--Factual information used as a basis for reasoning or inference.
- diversity--Diversity (H'') is a single statistic in which the number of species and evenness are combined. Diversity is high if there are many species and their abundance is more or less even. Low diversity results when species are few and abundance uneven. Care must be exercised in using this statistic as a collection with few species but high evenness can have the same value as a collection with many species and low evenness (see Shannon-Weaver Index).
- endofauna--Benthic animals in the bottom.
- epifauna--Animals that live on the surface of the bottom specifically, any encrusting fauna.
- evenness--Describes the relative abundance of the individuals of each species; e.g., if all species in the population have equal numbers of individuals, the evenness will be at its maximum. As the disparities among the abundances increase, the evenness approaches zero (see also J).

fauna--Animal life as opposed to plant life; generally the entire group of animals found in an area.

foredune--The front dune immediately behind the backshore.

groin (British, groyne)--A shore protection structure built (usually perpendicular to the shoreline) to trap littoral drift or retard erosion of the shore.

H''--See diversity and Shannon-Weaver Index.

interstitial--A term referring to the spaces between particles (e.g., the spaces between the sand grains).

intertidal zone--The zone bounded by the high and low water extremes of the tide.

J--This represents the ratio of the observed (calculated) diversity (H'') to the theoretical maximum diversity, given the same number of species (H'' max).

$$J = \frac{H''}{H'' \text{ max}}$$

See evenness.

Kruskal-Wallis Test--This is a nonparametric statistical method to test for the differences of location in ranked data grouped by a single classification. It determines whether the data come from the same or different populations based on the hypothesis that if the populations are the same the ranked sums of the data will be approximately the same.

littoral--Several uses in ecology: (1) The zone between extreme high and extreme low tides. (2) In lakes, shallow water from the shore to the light compensation level. (3) The zone from high tide level to the outer edge of the Continental Shelf.

macrofauna--Those animals equal to or larger than 0.5 millimeter in size.

macroinvertebrate--Invertebrate animals equal to or larger than 0.5 millimeter in size.

Mann-Whitney Test--This is a nonparametric statistical method using ranking of the differences between the means of the sample parameters from two samples. It tests the hypothesis that there is no difference between samples (populations).

mean--The arithmetic mean (simple average) of a sample is the most frequently used estimator of the true population mean μ . A bar over a symbol customarily denotes an average; that is,

\bar{X} = arithmetic mean of X

$$\bar{X} = \frac{\Sigma X}{\text{number of values}}$$

median--That value of a variable (in an ordered array) that has an equal number of items on either side of it.

nonparametric method--A statistical test that is not concerned with the specific parameters, but rather with the distribution of the variates. Also referred to as distribution free. See parameter.

oscillatory--Having a periodic motion backward and forward or vibrating or varying above and below a mean value.

parameter--A parameter is a measurable characteristic of a population. The mean is an example of a parameter.

patchiness--The clumped distribution of individuals, in which distribution is not random and the variance is significantly greater than the mean value, also referred to as aggregation or clustered distribution.

population--The population is the total number of individual observations about which inferences can be made. The population can exist anywhere, but it is limited in space and time.

quadrat--A quadrat is a plot used for ecological or population studies. It may be square, rectangular or circular. Areas of quadrats are commonly 0.1, 0.5, and 1.0 square meters.

random--A single element is randomly drawn from a population if that element was selected by any procedure that gives every element in the population an equal chance of being drawn.

replicates--Repeated samples from the same population. Replication is necessary to detect residual variation and to detect smaller and smaller deviation among means.

rose bengal dye--A bluish-red acid dye used as a biological stain to aid in sorting the animals from the sediment.

sample--Any subset of a population is called a sample of that population.

Shannon-Weaver Index--The purpose is to find the diversity (H'') in large sampled communities. The function is:

$$H'' = -\Sigma \frac{N_i}{N} \log_e \frac{N_i}{N}$$

N_i - the number or weight of individuals in the i^{th} species.

N - the total number or weight of individuals in the collection.

significant--The estimate of the parameter has been tested statistically and the estimate probably does not deviate from the parameter beyond the limits or normal sample variation.

similarity coefficient (or index)--Any one of many mathematical methods to measure intergroup likeness. The criteria and procedures used in classifying the information vary considerably from method to method. The coefficients and indices have no comparative statistical basis.

station--The geographic location at which the samples or observations are taken.

stratified sampling--The population or area to be sampled is divided into a number of parts called strata. Division may be by depth, habitat, nature of substrate or other logical criteria. Samples are drawn independently from each strata. The population mean is estimated by

$$\bar{y} = \frac{\sum N_h \bar{y}_h}{\sum N_h}$$

where N_h is the number of sampling units in the h^{th} strata and \bar{y}_h is the mean of the h^{th} strata. Note that the sizes of the strata must be known to compute this estimate.

subtidal--Below mean low water (lower low on the U.S. Pacific coast).

surf--The wave action in the area between the shoreline and the outermost limit of breakers.

surf beat--Irregular oscillations of the nearshore water level, with periods of the order of several minutes.

swash--The rush of water up onto the beach face following the breaking of a wave.

taxonomic group--An entity such as genus or species in a formal system of scientific nomenclature.

transect--In ecology, a straight line of variable length along which continuous or intermittent samples may be taken or observations may be made.

valid--True in a statistical sense. A valid hypothesis has been tested and accepted.

variance--This statistic (s^2) is one measure of how the sample values are distributed about the sample mean. It is calculated by:

$$s^2 = \frac{\sum x^2}{n - 1}$$

x - the deviation of the sample value from the sample mean ($\bar{x} - x_n$)

n - the number of sample values.

variable--In biostatistics, a property with respect to which individuals in a sample differ in some ascertainable way. If the variable is measurable it may be referred to as a parameter (see parameter).

variate--A single measurement, score, or observation of a variable.

wave gage--An instrument for measuring periodic fluctuations in water level with periods in the order of seconds.

Hurme, Arthur K.

Sampling macroinvertebrates on high-energy sand beaches / by Arthur K. Hurme, Robert M. Yancey, and Edward J. Pullen. - Fort Belvoir, Va. : U.S. Coastal Engineering Research Center ; Springfield, Va. : available from National Technical Information Service, 1979. 36 p. : ill. ; 27 cm. - (Coastal engineering technical aid ; CETA 79-3)

Cover title.

Bibliography : p. 26.

Report summarizes the most practical and cost-effective techniques developed from CERC-sponsored research and the literature for quantitatively sampling high-energy sand beach macroinvertebrates.

1. Coastal ecology. 2. Marine invertebrates. 3. Sampling.

I. Title. II. Yancey, Robert M., joint author. III. Pullen, Edward J., joint author. IV. Series: U.S. Coastal Engineering Research Center. Coastal engineering technical aid. CETA 79-3.

TC203

.U581ta

no. 79-3

627

Hurme, Arthur K.

Sampling macroinvertebrates on high-energy sand beaches / by Arthur K. Hurme, Robert M. Yancey, and Edward J. Pullen. - Fort Belvoir, Va. : U.S. Coastal Engineering Research Center ; Springfield, Va. : available from National Technical Information Service, 1979. 36 p. : ill. ; 27 cm. - (Coastal engineering technical aid ; CETA 79-3)

Cover title.

Bibliography : p. 26.

Report summarizes the most practical and cost-effective techniques developed from CERC-sponsored research and the literature for quantitatively sampling high-energy sand beach macroinvertebrates.

1. Coastal ecology. 2. Marine invertebrates. 3. Sampling.

I. Title. II. Yancey, Robert M., joint author. III. Pullen, Edward J., joint author. IV. Series: U.S. Coastal Engineering Research Center. Coastal engineering technical aid. CETA 79-3.

TC203

.U581ta

no. 79-3

627

Hurme, Arthur K.

Sampling macroinvertebrates on high-energy sand beaches / by Arthur K. Hurme, Robert M. Yancey, and Edward J. Pullen. - Fort Belvoir, Va. : U.S. Coastal Engineering Research Center ; Springfield, Va. : available from National Technical Information Service, 1979. 36 p. : ill. ; 27 cm. - (Coastal engineering technical aid ; CETA 79-3)

Cover title.

Bibliography : p. 26.

Report summarizes the most practical and cost-effective techniques developed from CERC-sponsored research and the literature for quantitatively sampling high-energy sand beach macroinvertebrates.

1. Coastal ecology. 2. Marine invertebrates. 3. Sampling.

I. Title. II. Yancey, Robert M., joint author. III. Pullen, Edward J., joint author. IV. Series: U.S. Coastal Engineering Research Center. Coastal engineering technical aid. CETA 79-3.

TC203

.U581ta

no. 79-3

627

Hurme, Arthur K.

Sampling macroinvertebrates on high-energy sand beaches / by Arthur K. Hurme, Robert M. Yancey, and Edward J. Pullen. - Fort Belvoir, Va. : U.S. Coastal Engineering Research Center ; Springfield, Va. : available from National Technical Information Service, 1979. 36 p. : ill. ; 27 cm. - (Coastal engineering technical aid ; CETA 79-3)

Cover title.

Bibliography : p. 26.

Report summarizes the most practical and cost-effective techniques developed from CERC-sponsored research and the literature for quantitatively sampling high-energy sand beach macroinvertebrates.

1. Coastal ecology. 2. Marine invertebrates. 3. Sampling.

I. Title. II. Yancey, Robert M., joint author. III. Pullen, Edward J., joint author. IV. Series: U.S. Coastal Engineering Research Center. Coastal engineering technical aid. CETA 79-3.

TC203

.U581ta

no. 79-3

627

Hurme, Arthur K.

Sampling macroinvertebrates on high-energy sand beaches / by Arthur K. Hurme, Robert M. Yancey, and Edward J. Pullen. - Fort Belvoir, Va. : U.S. Coastal Engineering Research Center ; Springfield, Va. : available from National Technical Information Service, 1979. 36 p. : ill. ; 27 cm. - (Coastal engineering technical aid ; CETA 79-3)

Cover title.

Bibliography : p. 26.

Report summarizes the most practical and cost-effective techniques developed from CEREC-sponsored research and the literature for quantitatively sampling high-energy sand beach macroinvertebrates.

I. Coastal ecology. 2. Marine invertebrates. 3. Sampling. I. Title. II. Yancey, Robert M., joint author. III. Pullen, Edward J., joint author. IV. Series: U.S. Coastal Engineering Research Center. Coastal engineering technical aid. CETA 79-3.

TC203

.US81ta

no. 79-3

627

Hurme, Arthur K.

Sampling macroinvertebrates on high-energy sand beaches / by Arthur K. Hurme, Robert M. Yancey, and Edward J. Pullen. - Fort Belvoir, Va. : U.S. Coastal Engineering Research Center ; Springfield, Va. : available from National Technical Information Service, 1979. 36 p. : ill. ; 27 cm. - (Coastal engineering technical aid ; CETA 79-3)

Cover title.

Bibliography : p. 26.

Report summarizes the most practical and cost-effective techniques developed from CEREC-sponsored research and the literature for quantitatively sampling high-energy sand beach macroinvertebrates.

I. Coastal ecology. 2. Marine invertebrates. 3. Sampling. I. Title. II. Yancey, Robert M., joint author. III. Pullen, Edward J., joint author. IV. Series: U.S. Coastal Engineering Research Center. Coastal engineering technical aid. CETA 79-3.

TC203

.US81ta

no. 79-3

627

Hurme, Arthur K.

Sampling macroinvertebrates on high-energy sand beaches / by Arthur K. Hurme, Robert M. Yancey, and Edward J. Pullen. - Fort Belvoir, Va. : U.S. Coastal Engineering Research Center ; Springfield, Va. : available from National Technical Information Service, 1979. 36 p. : ill. ; 27 cm. - (Coastal engineering technical aid ; CETA 79-3)

Cover title.

Bibliography : p. 26.

Report summarizes the most practical and cost-effective techniques developed from CEREC-sponsored research and the literature for quantitatively sampling high-energy sand beach macroinvertebrates.

I. Coastal ecology. 2. Marine invertebrates. 3. Sampling. I. Title. II. Yancey, Robert M., joint author. III. Pullen, Edward J., joint author. IV. Series: U.S. Coastal Engineering Research Center. Coastal engineering technical aid. CETA 79-3.

TC203

.US81ta

no. 79-3

627

Hurme, Arthur K.

Sampling macroinvertebrates on high-energy sand beaches / by Arthur K. Hurme, Robert M. Yancey, and Edward J. Pullen. - Fort Belvoir, Va. : U.S. Coastal Engineering Research Center ; Springfield, Va. : available from National Technical Information Service, 1979. 36 p. : ill. ; 27 cm. - (Coastal engineering technical aid ; CETA 79-3)

Cover title.

Bibliography : p. 26.

Report summarizes the most practical and cost-effective techniques developed from CEREC-sponsored research and the literature for quantitatively sampling high-energy sand beach macroinvertebrates.

I. Coastal ecology. 2. Marine invertebrates. 3. Sampling. I. Title. II. Yancey, Robert M., joint author. III. Pullen, Edward J., joint author. IV. Series: U.S. Coastal Engineering Research Center. Coastal engineering technical aid. CETA 79-3.

TC203

.US81ta

no. 79-3

627