

AD-A077 074

NATIONAL AVIATION FACILITIES EXPERIMENTAL CENTER ATL--ETC F/G 4/2  
MANUAL VOICE INPUT SUBSYSTEM OF THE NAFEC MASS WEATHER DISSEMIN--ETC(U)  
NOV 79 P QUICK , L DELEMARRE  
FAA-NA-79-21

UNCLASSIFIED

FAA-RD-79-12

NL

1 OF 1  
AD-  
AD77074



END  
DATE  
FILMED  
12-79  
DDC

12

# MANUAL VOICE INPUT SUBSYSTEM OF THE NAFEC MASS WEATHER DISSEMINATION SYSTEM

## LEVEL

Paul Quick  
Louis Delemarre



NOVEMBER 1979

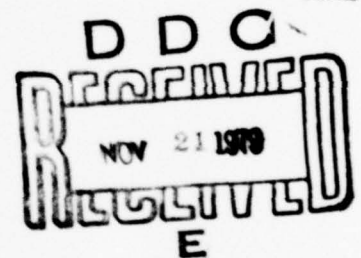

### INTERIM REPORT

Document is available to the U.S. public through the National Technical Information Service, Springfield, Virginia 22161.

Prepared for

**U.S. DEPARTMENT OF TRANSPORTATION**  
**FEDERAL AVIATION ADMINISTRATION**  
Systems Research & Development Service  
Washington, D.C. 20590

79 11 19 106

AD A 077074

DDC FILE COPY

NOTICE

The United States Government does not endorse products or manufacturers. Trade or manufacturer's names appear herein solely because they are considered essential to the object of this report.

Technical Report Documentation Page

1. Report No. <b>18</b> FAA-RD-79-12	2. Government Accession No.	3. Recipient's Catalog No.	
<b>6</b> <u>MANUAL VOICE INPUT SUBSYSTEM OF THE NAFEC MASS WEATHER DISSEMINATION SYSTEM</u>		<b>11</b> Report Date November 1979	6. Performing Organization Code
<b>10</b> Author(s) Paul Quick Louis Delemarre		<b>14</b> 8. Performing Organization Report No. FAA-NA-79-21	9. Work Unit No. (TRAILS)
9. Performing Organization Name and Address Federal Aviation Administration National Aviation Facilities Experimental Center Atlantic City, New Jersey 08405		11. Contract or Grant No. 131-401-800	13. Type of Report and Period Covered Interim
12. Sponsoring Agency Name and Address U.S. Department of Transportation Federal Aviation Administration Systems Research and Development Service Washington, D.C. 20590		14. Sponsoring Agency Code	
15. Supplementary Notes <b>12</b> 3φ			
16. Abstract This report describes the manual voice input subsystem of the prototype Mass Weather Dissemination System currently being designed and tested in the FSS Engineering Development Laboratory. The object of this effort is to investigate through development, test, and evaluation the application of digital technology to the mass dissemination of meteorological and aeronautical information. The prototype model is a fully automated system designed to transfer a significant amount of workload from the FSS specialist to system hardware and to provide better service to the flying public. <b>9</b> Interim rept.			
17. Key Words Manual Voice Input System Voice Encoder Voice Decoder Flight Service Station Automation Weather Data Dissemination		18. Distribution Statement Document is available to U.S. public through the National Technical Information Service, Springfield, Virginia 22161	
19. Security Classif. (of this report) Unclassified	20. Security Classif. (of this page) Unclassified	21. No. of Pages 27	22. Price

240550 LHM

# METRIC CONVERSION FACTORS

Approximate Conversions to Metric Measures			Approximate Conversions from Metric Measures			
Symbol	When You Know	Multiply by	To Find	Symbol	When You Know	
<b>LENGTH</b>						
m	meters	1.0936	feet	ft	feet	
cm	centimeters	0.3937	inches	in	inches	
mm	millimeters	0.0394	inches	in	inches	
km	kilometers	0.6214	miles	mi	miles	
<b>AREA</b>						
m <sup>2</sup>	square meters	1.196	square feet	sq ft	square feet	
cm <sup>2</sup>	square centimeters	0.155	square inches	sq in	square inches	
ha	hectares (10,000 m <sup>2</sup> )	2.471	acres	ac	acres	
<b>MASS (weight)</b>						
kg	kilograms	2.205	pounds	lb	pounds	
g	grams	0.035	ounces	oz	ounces	
t	tonnes (1,000 kg)	1.102	short tons	st	short tons	
<b>VOLUME</b>						
l	liters	1.057	quarts	qt	quarts	
ml	milliliters	0.0338	fluid ounces	fl oz	fluid ounces	
m <sup>3</sup>	cubic meters	35.234	cubic feet	cu ft	cubic feet	
dm <sup>3</sup>	cubic decimeters	0.264	gallons	gal	gallons	
<b>TEMPERATURE (exact)</b>						
°C	Celsius temperature	1.8 (then add 32)	Fahrenheit temperature	°F	Fahrenheit temperature	
°F	Fahrenheit temperature	5/9 (after subtracting 32)	Celsius temperature	°C	Celsius temperature	

\*1 in. = 2.54 centimeters. For other exact conversions and more detailed tables, see NBS Mon. Publ. 286, Units of Length and Measure, Price \$2.25, SO Catalog No. C73-10-286.

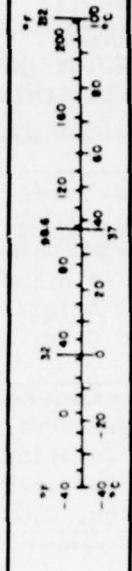

PREFACE

Acknowledgment is given to Ephraim Shochet for his assistance in the development of this report. Through his efforts, a set of design and laboratory notes have been incorporated into this document.

Accession For	
NTIS GRA&I	<input checked="" type="checkbox"/>
DSC TAB	<input type="checkbox"/>
Unannounced	
Justification	
By _____	
Distribution/	
Availability Codes	
Dist	Avail and/or special
<b>A</b>	

## TABLE OF CONTENTS

	Page
INTRODUCTION	1
BACKGROUND	1
DESIGN OBJECTIVES	1
OPERATIONAL DESCRIPTION	3
Manual Voice Input System	3
Voice Encoder	6
Voice Decoder	9
SUMMARY	11
APPENDIX	

LIST OF ILLUSTRATIONS

Figure		Page
1	Mass Weather Dissemination Exploratory Engineering Model	2
2	Manual Voice Input Subsystems	4
3	List of System Commands	7
4	Voice Encoder Flow Diagram	8
5	Voice Decoder Flow Diagram	10

## INTRODUCTION

This report describes the manual voice input system of the National Aviation Facilities Experimental Center (NAFEC) Prototype Mass Weather Dissemination System. A general overall description of the manual voice subsystem is presented, followed by a detailed description of the voice encoder and the voice decoder elements.

## BACKGROUND

The Mass Weather Dissemination Exploratory Engineering Model (figure 1) was developed to test and evaluate the application of digital technology to the mass dissemination of meteorological and aeronautical information.

A Department of Transportation (DOT) study, "A Proposal for the Future of Flight Stations," dated August 1973, recommended that greater emphasis be placed on the mass dissemination of aviation weather briefings at flight service stations (FSS's) and that the one-to-one method of briefing be reduced or eliminated.

"There is a need to reduce or eliminate the one-to-one method of briefing, particularly for heavily traveled routes or repetitive briefings. The function lends itself quite well to automation. Therefore, automation (self briefing) and mass dissemination should be emphasized."

## DESIGN OBJECTIVES

The design objectives of the Mass Weather Dissemination Exploratory Engineering Model are:

1. To provide, through one-call, one-number service:
  - a. Access to any of five recorded briefings.
  - b. Access to a flight service specialist.
  - c. Access to Automated Flight Plan System to file, amend, and close flight plans.
2. Reduce specialists workload by:
  - a. Providing updated, accessible, recorded weather briefings.
  - b. Increasing the efficiency with which specialists enter information to the recorded briefing system.
  - c. Almost entirely eliminating recording of spoken information by means of automatic message composition by phrase selection from preformatted menus.



Telco Terminal Equipment

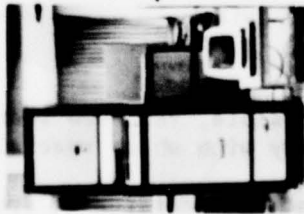

Utterance Recognition Device



Auto Mess Comp Entry Terminal

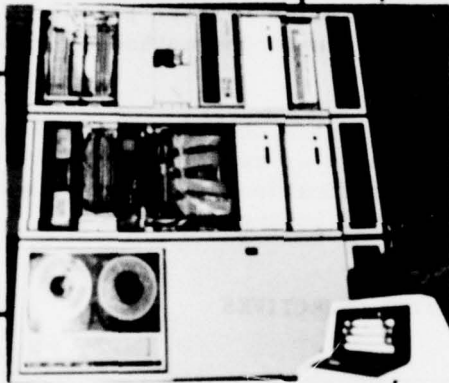

7/32 Computer, Bulk Store,  
Voice Digitizer, Telco line Controller  
&  
Telco Output Channel Interface

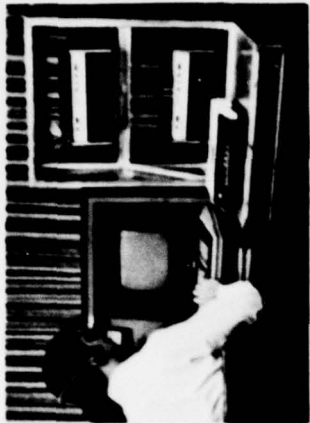

Fast File Recorders  
Flight Plan Entry Console



Specialist Answering Set at Console



Specialist Message Entry Terminal

FIGURE 1. MASS WEATHER DISSEMINATION EXPLORATORY ENGINEERING MODEL

- d. Providing flight plan recordings with feedback.
  - e. Automating the flight plan filing process.
3. Improve service to the pilot by providing:
- a. Synchronous access; i.e., the presentation of a recorded briefing from the beginning to any pilot.
  - b. One-number access (briefing/caller multiplex). Any pilot calling the system via the one telephone number can access all FSS services.
  - c. All-pilot access. Any pilot with any telephone can access the system.
  - d. No-break update. Updates in the recorded briefings are transparent to the pilot.
4. To provide operational economy by:
- a. Reduced line costs. One-call, one-number service with system function to caller multiplex results in the dynamic allocation of telephone line use, thus reducing idle lines.

## OPERATIONAL DESCRIPTION

### MANUAL VOICE INPUT SUBSYSTEM.

The detailed flow diagrams of the manual voice input subsystem are included in the appendix of this report. The specialist console contains three system subelements. A diagram of the manual voice input subsystem is shown in figure 2. A microphone and audio preamplifier, which are located at the specialist console, and the voice encoder enable the specialist to speak messages into the system. A loudspeaker, located on the specialist console, and the voice decoder enable the specialist to listen to previously spoken messages. A computer terminal (consisting of a Conrac monitor, an Ann Arbor keyboard, and an Ann Arbor cathode-ray tube (CRT) controller) allows the specialist to interact with the processor. The Ann Arbor CRT controller communicates with the processor via an RS-232 interface.

The NAFEC Mass Weather Dissemination System is configured to disseminate five different messages, each of which can be a maximum of 10 minutes duration. Each message is subdivided into 15 message segments. Messages are automatically composed by speaking message segments into the system one at a time. The duration of message segments can be variable in length, the only restriction being that the sum total time of all active segments cannot exceed the maximum system capacity of 78-minutes. Message segments which are common to all messages are updated simultaneously and automatically for all messages when a message segment input is made.

The specialist controls the system through a CRT terminal. He enters commands via a keyboard and observes the response on the CRT. The commands

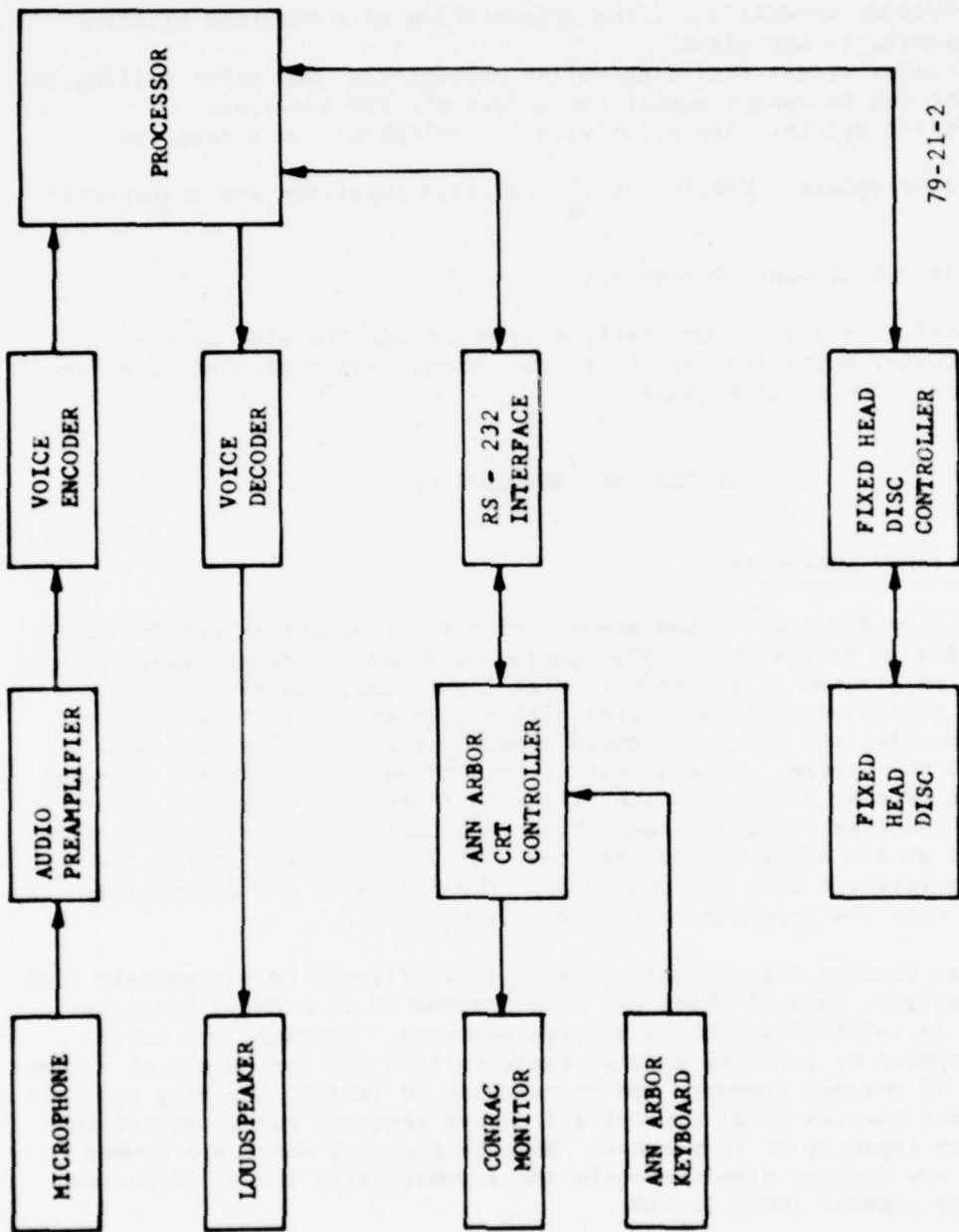

FIGURE 2. MANUAL VOICE INPUT SUBSYSTEMS

provided for the specialist are entitled: TALK, REVIEW, UPDATE, KILL, MAP, LISTEN, PLAYBACK, DELETE, ABORT, and HELP.

When the specialist types TALK on his console followed by a message segment name, the processor responds with a visual display of the word TALK, and the specialist then begins speaking the message segment into the system. The processor enables the voice encoder and begins storing digitized voice data into an appropriate voice data file. After he has spoken the message segment, the specialist depresses the carriage return key.

At this time, the message segment just spoken into the system is not yet available for dissemination. The UPDATE command must be executed before a message is available for dissemination.

The specialist can review the message segment just spoken into the system by typing the word REVIEW followed by the message segment name. The processor retrieves the appropriate voice data file, converts the digitized voice to audio in the voice decoder, and plays it to the specialist via a loudspeaker. When the specialist is satisfied with the message segment, he types UPDATE, followed by the message segment name. The UPDATE command replaces the current voice data file (if one exists) with the new voice data file. The old voice data file (if one exists) is put on a time-delayed delete list, and will be deleted by the system automatically in 10 minutes. If the specialist is not satisfied with the previously spoken message segment, he can eliminate it by typing the word KILL. The KILL command deletes the current voice file immediately and makes it available for the next spoken message segment. Should the specialist forget the name of the currently spoken message segment, he can retrieve it by typing CURRENT. The processor will respond with the name of the last message segment which was spoken into the system.

The MAP command allows the specialist to monitor a listing of the message segment content of any message. After typing MAP, followed by a message name, the processor sends the list of all possible message segment names and indicates which of the message segments are currently active (i.e., have data currently entered in the associated file).

The specialist can listen to any currently active message segment to verify its existence or voice quality. After typing LISTEN, followed by the message segment name, the processor retrieves the appropriate voice data file and plays it through the loudspeaker via the voice decoder.

An entire message can be monitored by the specialist by typing PLAYBACK and the message name. Each currently active message segment which constitutes the message is played through the loudspeaker via the voice decoder.

A message segment can be deleted by typing DELETE and the message segment name which is to be deleted. The voice data file for that message segment is then placed on a time-delayed delete list. Ten minutes later, that voice data file is automatically purged from the system.

The ABORT command allows the specialist to recover from an error. ABORT, followed by a message segment name, results in the current voice data file for that segment being placed on the time-delayed delete list. The old voice data file for that message segment becomes the current voice data file for that message segment. If the 10-minute timer had already elapsed for the old voice data file, an abort is not possible, an error message is sent to the CRT, and the current message segment remains unchanged.

By typing HELP, the specialist is presented with a list of the system commands on his CRT. Each command is followed by text which describes the command. Typing the HELP command displays the information as shown in figure 3.

Extensive error correction is employed in the specialist command software. If either an illegal command, a legal command with an invalid message segment name, or a legal command which fails to meet appropriate prerequisites is attempted, the command is ignored, and an appropriate error message is sent to the CRT.

#### VOICE ENCODER.

The voice encoder takes an analog voice signal, filters the signal, performs analog-to-digital conversions on the filtered signal, encodes the digital voice samples, and presents the encoded digital voice data to the host processor for storage and subsequent retrieval for dissemination (see figure 4).

The analog audio input is first passed through a variable gain amplifier. The gain of this amplifier is set such that the analog-to-digital converter is not overloaded during peak excursions of the input signal. An LM741 operational amplifier was chosen to implement this function.

After passing through the variable gain amplifier, the analog voice signal is passed through an antialiasing filter. This low-pass filter is set to have a gain of 1, a Q factor of 1, a rolloff of 48 decibels (dB) per octave, and a cutoff frequency of 2.8 kilohertz (kHz). Four Burr Brown UAF-41 universal active filters were used to fabricate this filter. Specific connections to the UAF-41 and equations for external resistor selection may be found in the Burr Brown UAF-41 data sheet dated September 1976.

An SHM-IC-1 integrated circuit was chosen to implement the sample-and-hold amplifier. At the beginning of each data conversion cycle, this device holds the output of the antialiasing filter at a constant value and maintains the constant value until the data conversion cycle is completed. Specific information concerning this integrated circuit may be found in Intel's model SHM-IC-1 data sheet dated April 1976.

The heart of the voice encoder is a companding analog-to-digital converter which is implemented with three integrated circuits. These integrated circuits include an LM311 comparator, a DM2502 successive approximation

<u>COMMAND</u>	<u>OPERAND</u>	<u>DEFINITION</u>
* TALK	Segment Name	This command allows the specialist to ** prepare a message element. **
* REVIEW	Segment Name	This command is used to audition the current message element before entry into the system.
* UPDATE	Segment Name	This command causes the current message element to be entered into the system with auto time-delay deletion of old segment, if one exists.
* ABORT	Segment Name	This command cancels a previous update command by replacing the updated message segment with the old saved segment and deleting the update.
* LISTEN	Segment Name	This command allows the specialist to hear any message segment in the system, if it exists.
* DELETE	Segment Name	This command allows the specialist to delete any message segment in the system, if it exists.
* MAP	Message Type	This command will map out the segment names of any one of the 5 messages and indicate which are active.
* CURRENT	"Update"	This command allows the specialist to obtain the name of the present update segment, if one exists.
* KILL	"Update"	This command allows the specialist to immediately delete the update before entry into the system.

FIGURE 3. LIST OF SYSTEM COMMANDS

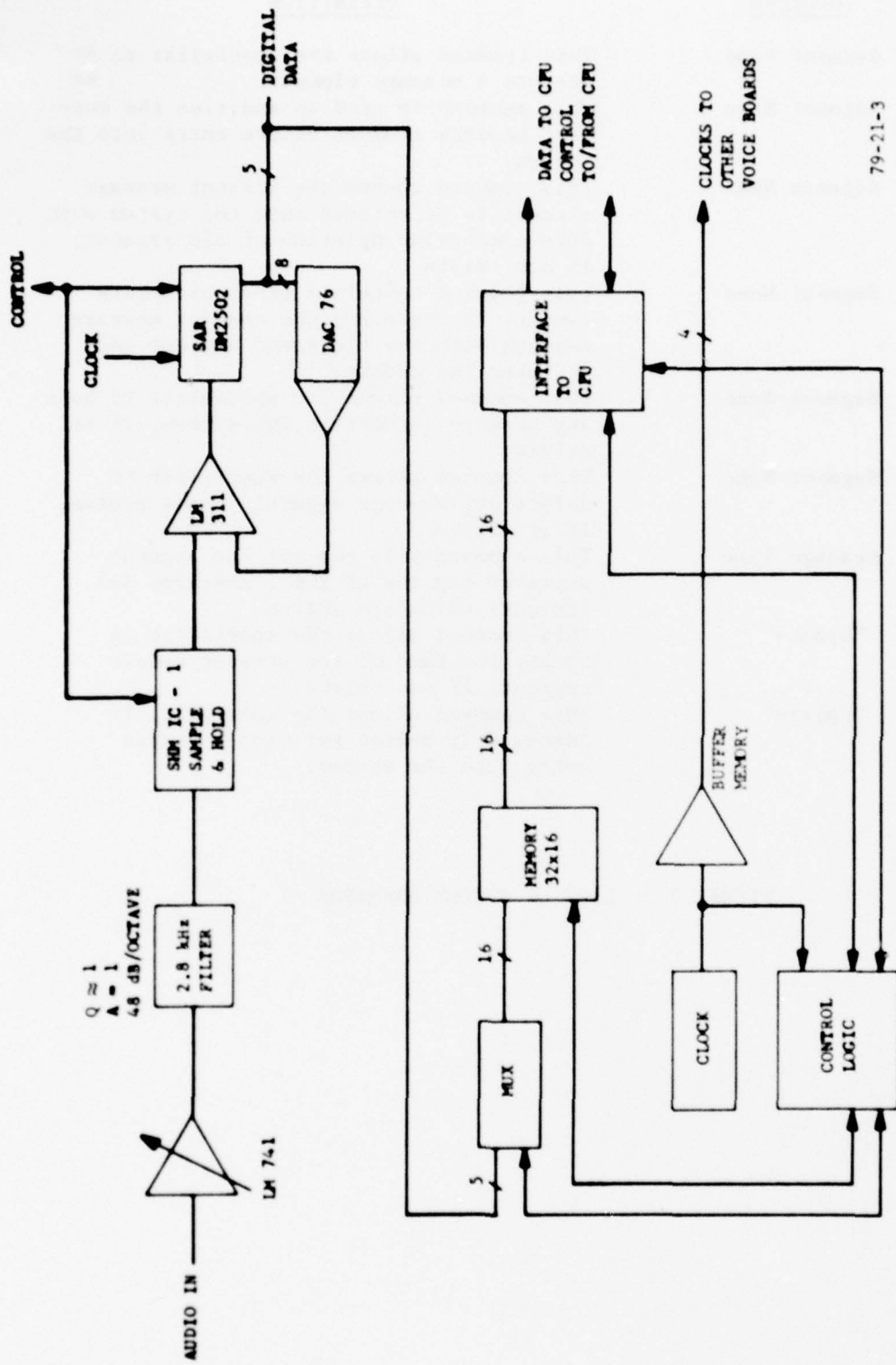

79-21-3

FIGURE 4. VOICE ENCODER FLOW DIAGRAM

register, and a DAC-76 companding digital-to-analog converter. The analog-to-digital converter is fabricated as suggested in the Precision Monolithics Inc. DAC-76 data sheet dated April 1976 under the category of "Detailed Encoder Connections." Detailed timing considerations for DM2502 successive approximation register are found in the National Semiconductor (TTL) Data Book dated February 1976 on pages 4-6 through 4-10.

Five-bit voice samples from the analog-to-digital converter are fed to the multiplexer which assembles the voice samples into 16-bit words. When the multiplexer has assembled a 16-bit word, the word is placed in memory. Implementation of the multiplexer was accomplished with 74175 and 74174 D-type flip-flops.

Memory prevents the potential loss of digitized voice data when the processor is temporarily too busy to respond to the encoder's data available request. Eight CD40105 first-in-first-out (FIFO) memory integrated circuits were used to implement a memory organized into 32 words of 16 bits per word. Detailed information may be found in RCA's preliminary data sheet for the CD40105 integrated circuit, which is dated April 1977.

At any time that data are available in the memory, the processor is interrupted via the control logic. Memory data are then presented to the processor interface. Interrupts continue to be generated until the memory contains no more voice data.

The clock determines the sample rate of the encoder. It is crystal-controlled and digitally variable via strap options. The clock is used by the control logic and is buffered to all other voice boards in the system. A crystal-controlled field effect transistor (FET) oscillator and three 74177 presetable four-bit binary counters were used to implement the clock.

#### VOICE DECODER.

The voice decoder takes digitally encoded voice data from the processor, converts the digital voice samples back into the analog domain, low-pass filters the raw analog voice signal, and amplifies and plays the filtered voice signal into a loudspeaker (see figure 5).

Sixteen-bit data words are presented to the decoder memory via the processor interface. The memory is organized into 32 words, 16 bits in length, and is implemented using 8 CD40105 FIFO memory integrated circuits. Specific interconnection data and timing considerations for the FIFO memory are available in RCA's preliminary CD40105 data sheet dated April 1977. Whenever the memory has a vacant word, it interrupts the processor to fill that vacancy. Interrupts continue until the memory is full. The memory allows voice to be continuously generated even when the processor is temporarily too busy to respond to the decoder's data request.

Data from the memory are passed through a demultiplexer which separates the 5-bit voice samples from the 16-bit word. Three 74153 integrated circuits

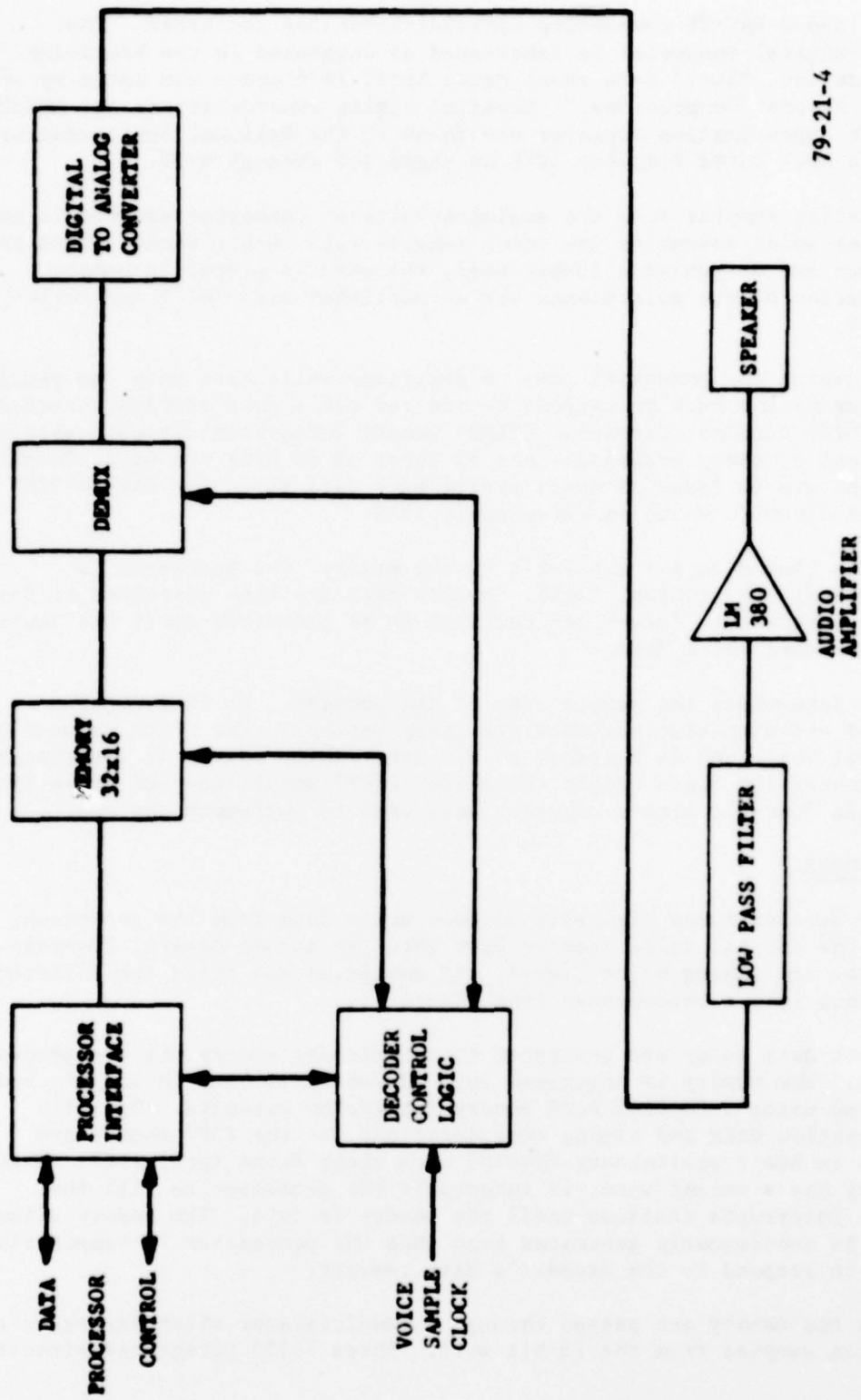

79-21-4

FIGURE 5. VOICE DECODER FLOW DIAGRAM

were chosen to implement this function. When the demultiplexer has completely disassembled a 16-bit word, it requests another from the memory, and this process continues until the memory is empty.

Five-bit voice samples from the demultiplexer are applied to the inputs of the digital-to-analog converter. Here, the digital voice samples are converted back into the analog domain. The digital-to-analog converter consists of a DAC-76 companding digital-to-analog converter and an LM741 operational amplifier integrated circuit. Detailed circuit diagrams may be found in Precision Monolithics Inc., DAC-76 data sheet dated April 1976 under the category of "Basic Decode Connections."

The raw analog voice signal from the digital-to-analog converter is passed through a low-pass filter. This filter has a gain of 1, a Q factor of 1, a cutoff frequency of 2.8 kHz, and a rolloff of 48 dB per octave. Implementation of the filter was accomplished by using four Burr Brown UAF-41 universal active filters. Specific connections of the UAF-41 integrated circuit as well as equations for determination of external resistor values are available in the Burr Brown UAF-41 data sheet dated September 1976.

The output of the low-pass filter is amplified by an LM380 2-watt audio amplifier integrated circuit. The LM380 drives a speaker which is mounted on the specialist console.

#### SUMMARY

The voice input system is an integral and presently functional subsystem of the NAFEC FSS exploratory engineering model Mass Weather Dissemination System. The operational procedures and equipments delineated, though subject to modification in an ongoing developmental effort, have accomplished voice-generated meteorological and aeronautical message composition and updating in the FSS environment.

APPENDIX

SPECIALIST POSITION FLOW DIAGRAM

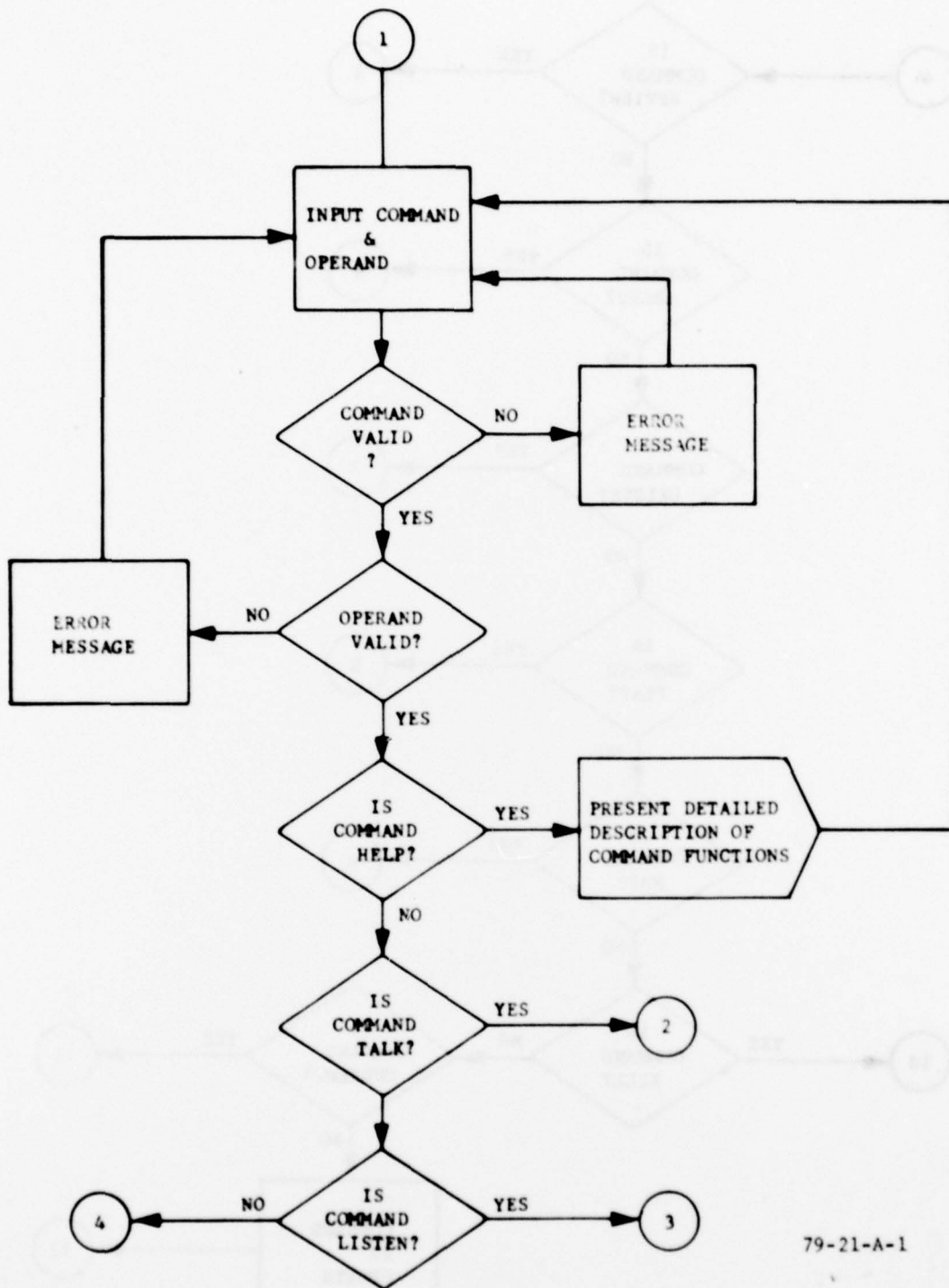

79-21-A-1

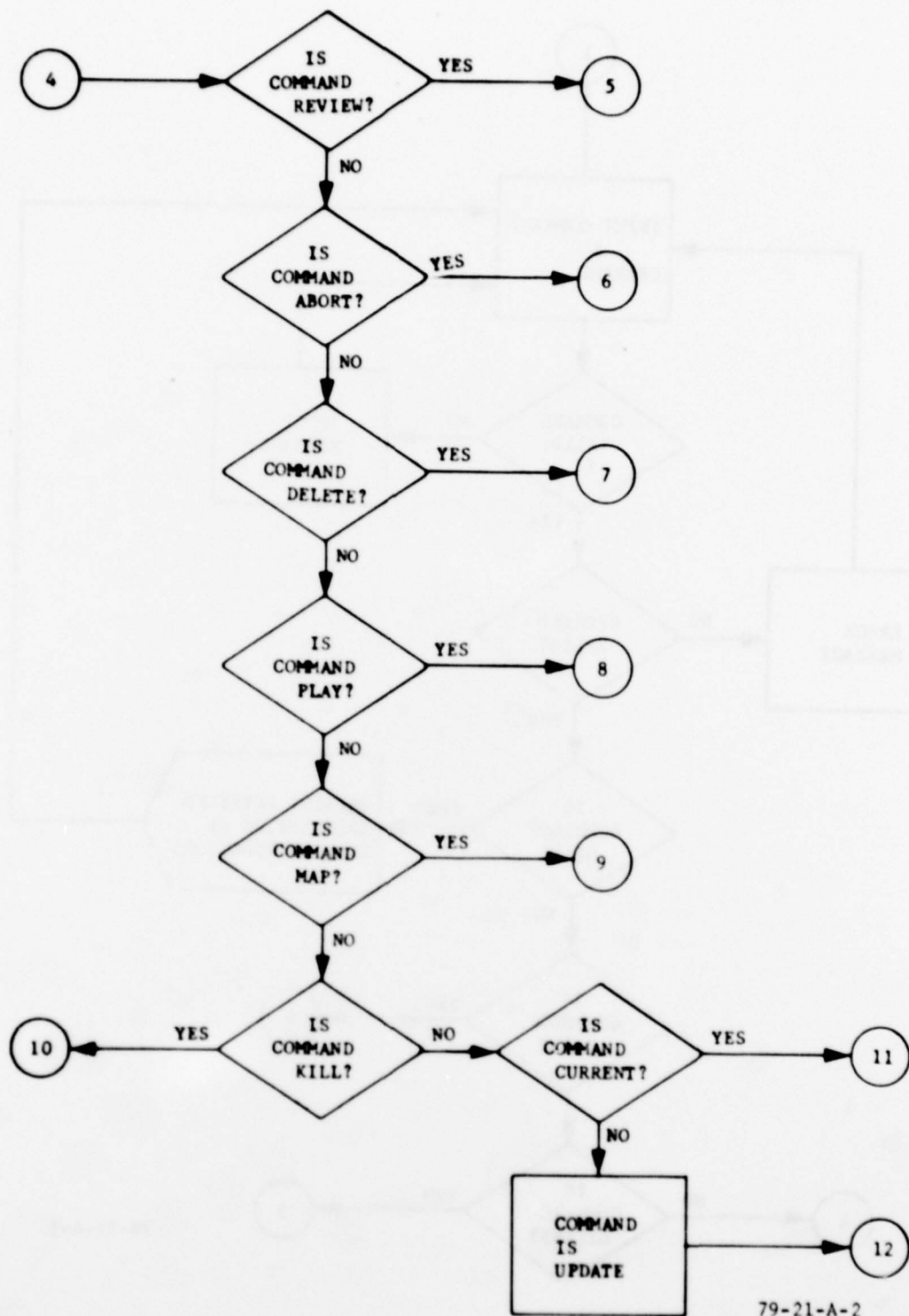

79-21-A-2

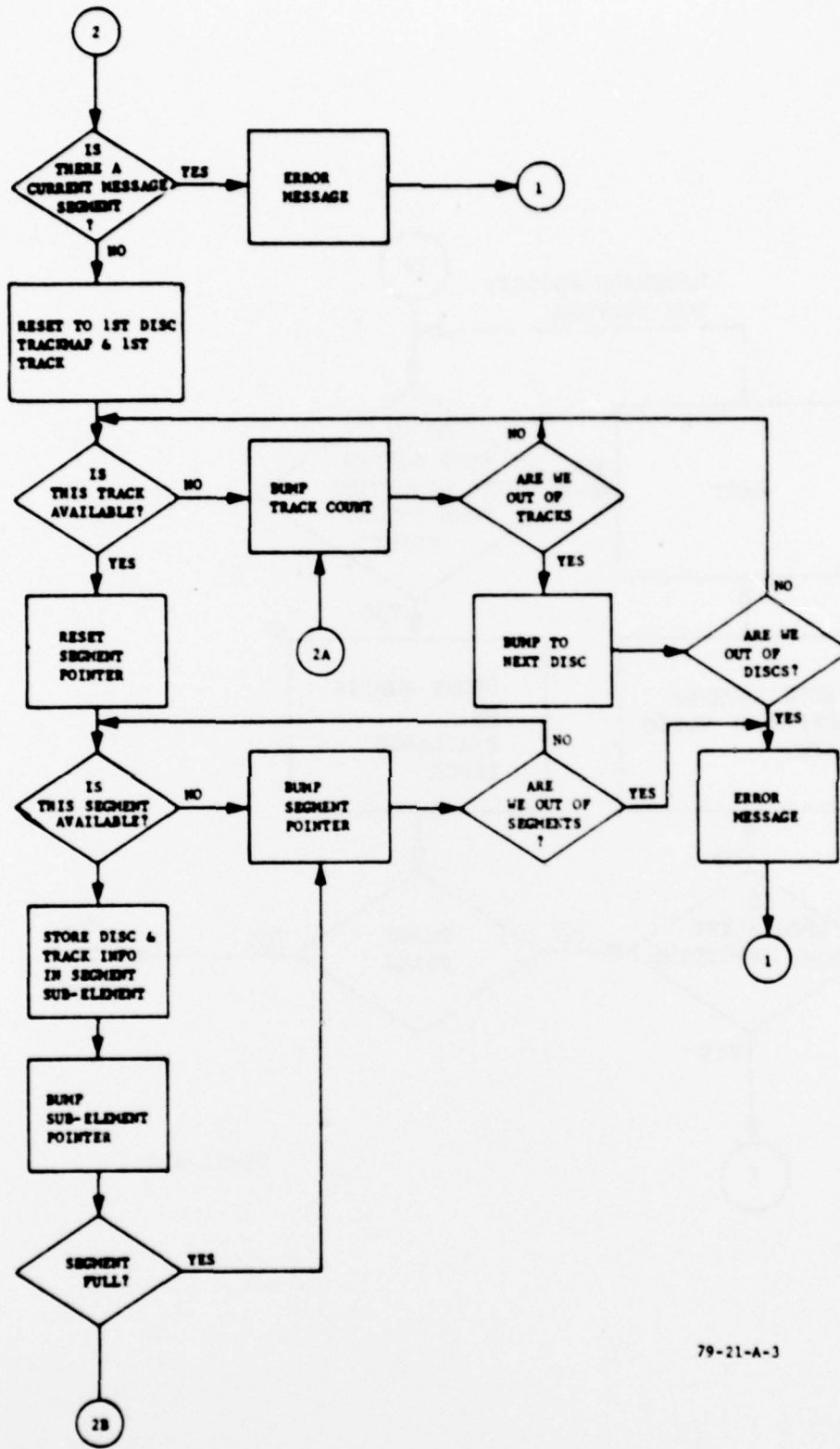

79-21-A-3

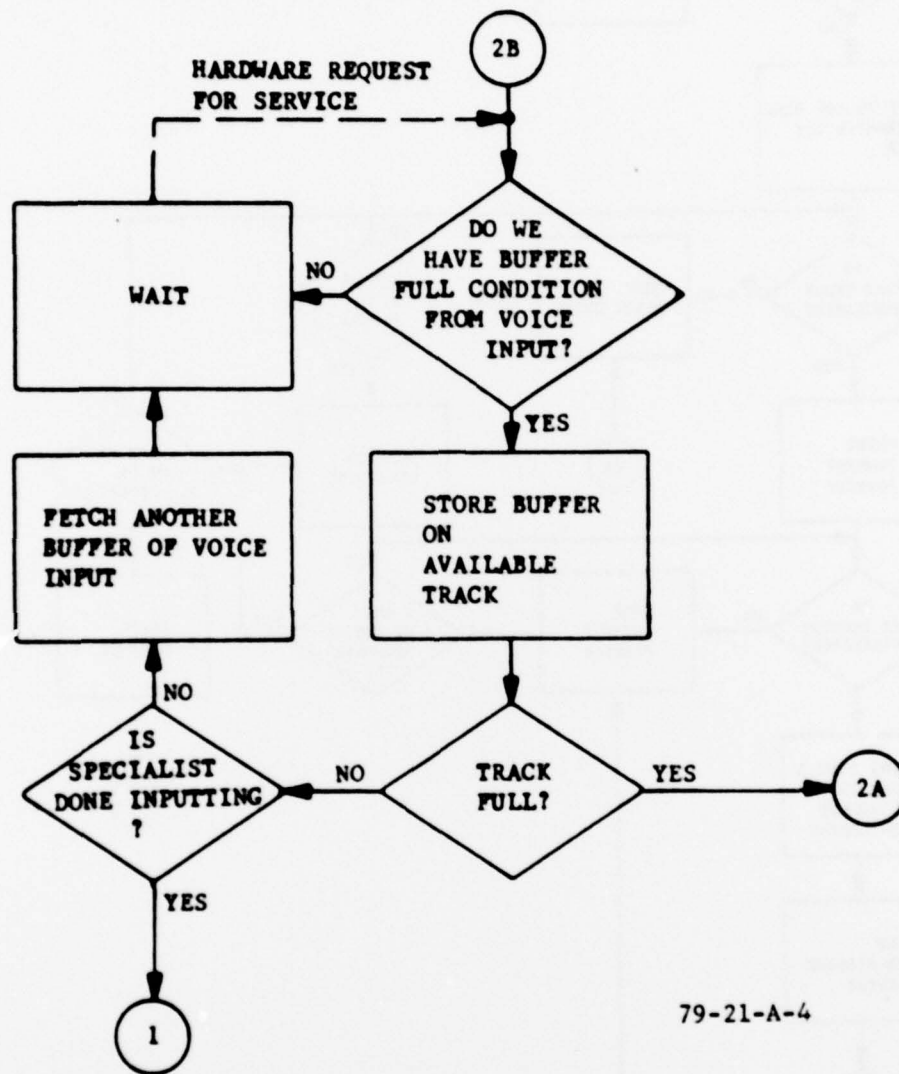

79-21-A-4

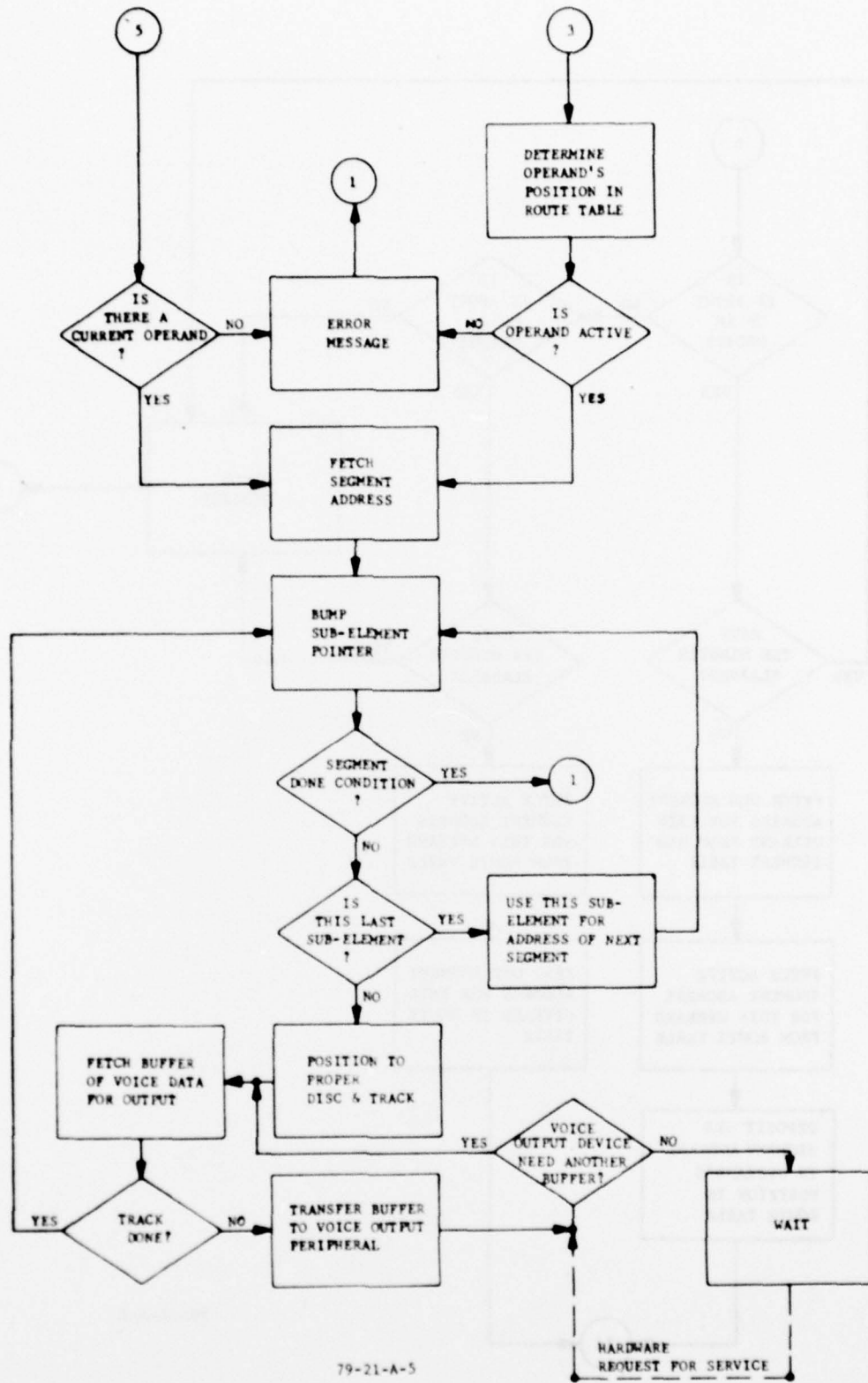

79-21-A-5

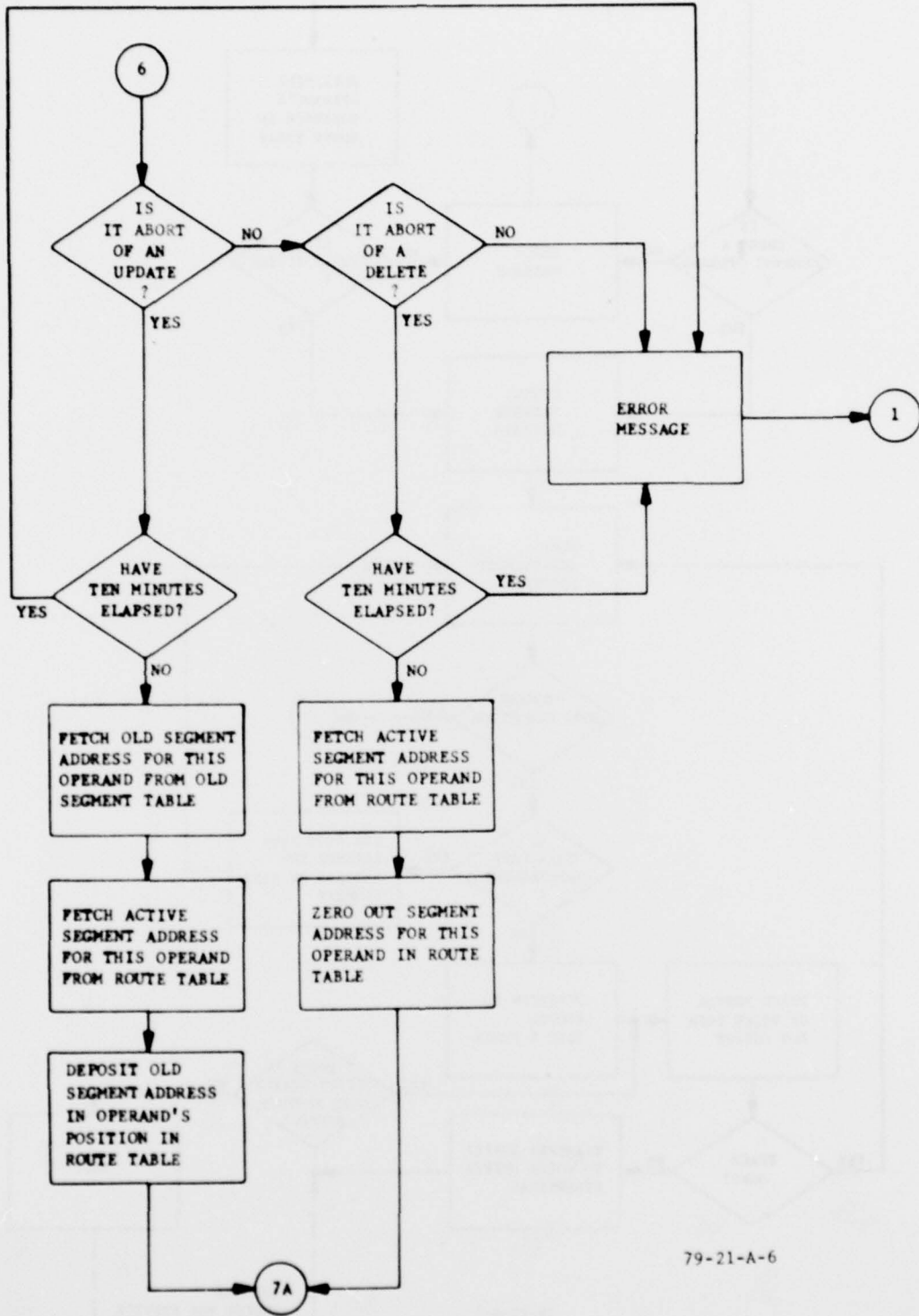

79-21-A-6

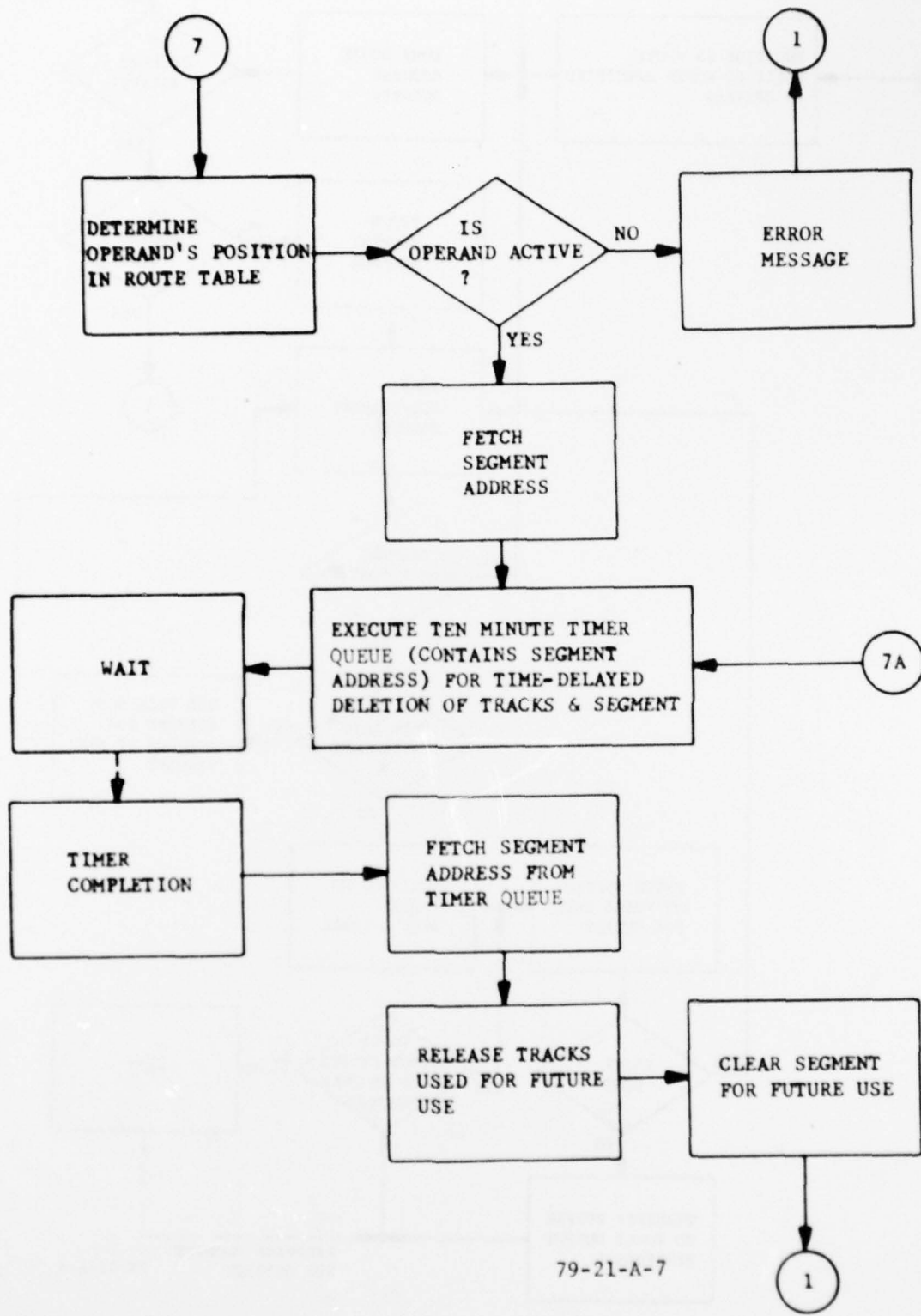

79-21-A-7

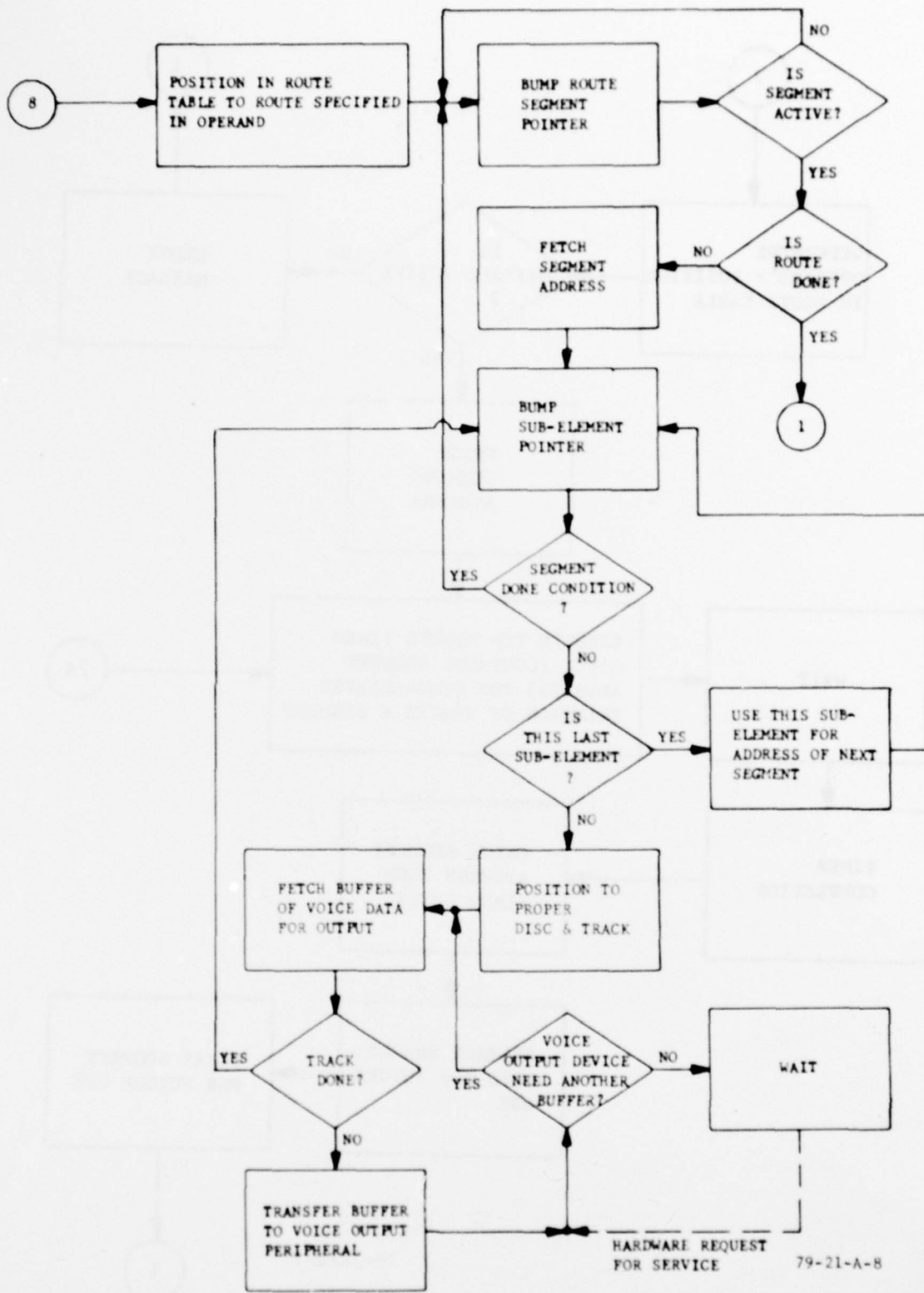

79-21-A-8

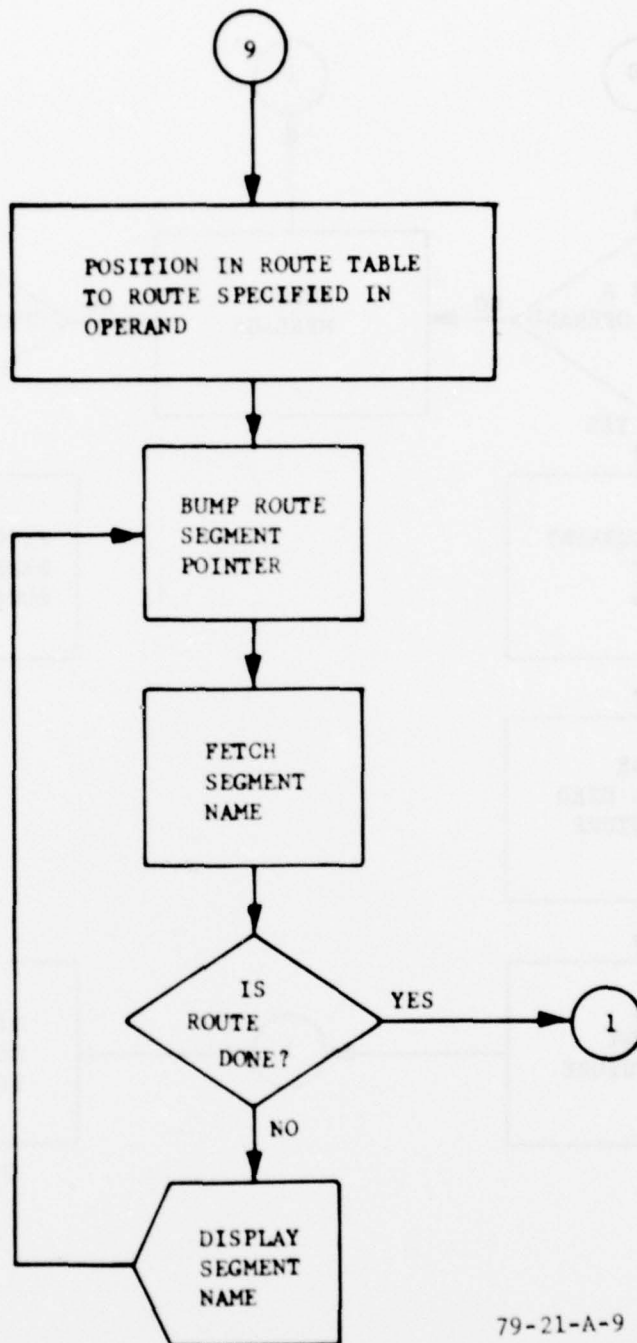

79-21-A-9

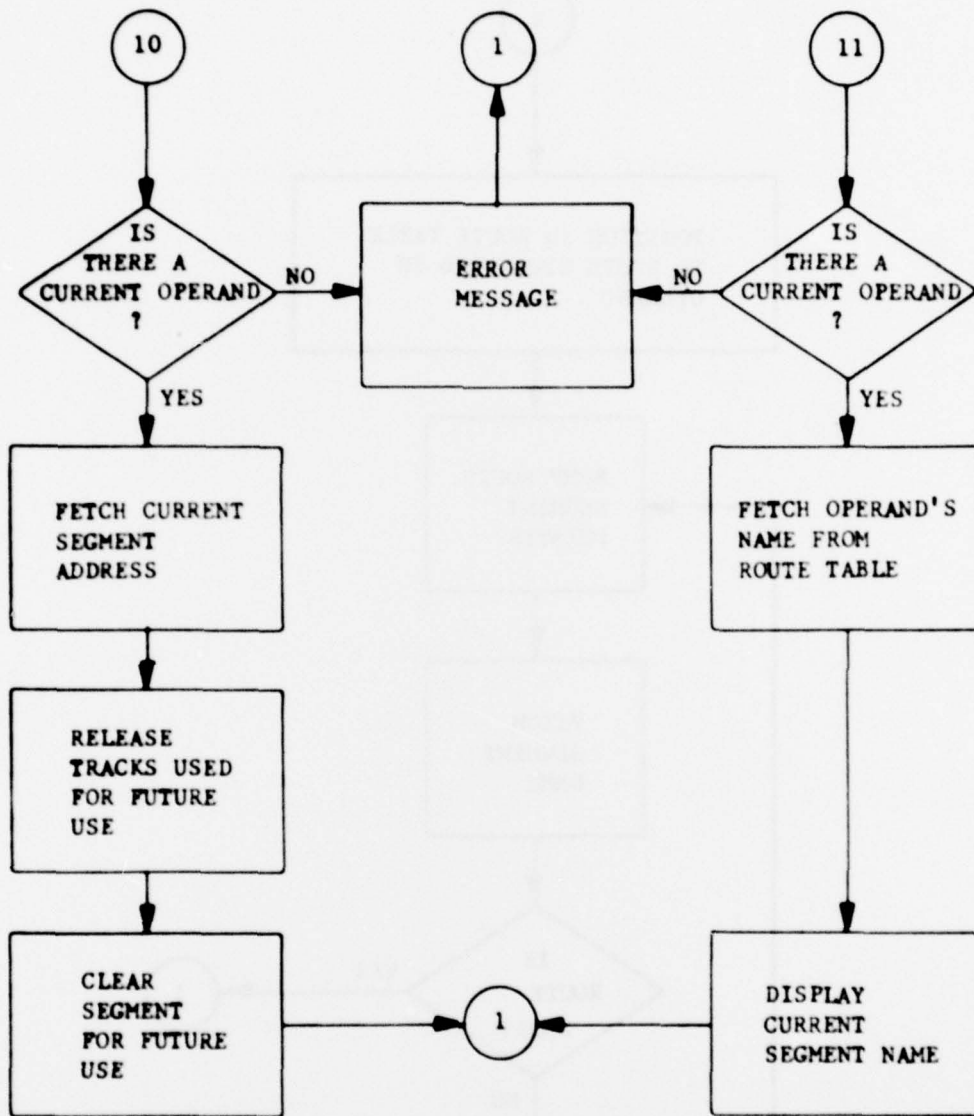

79-21-A-10

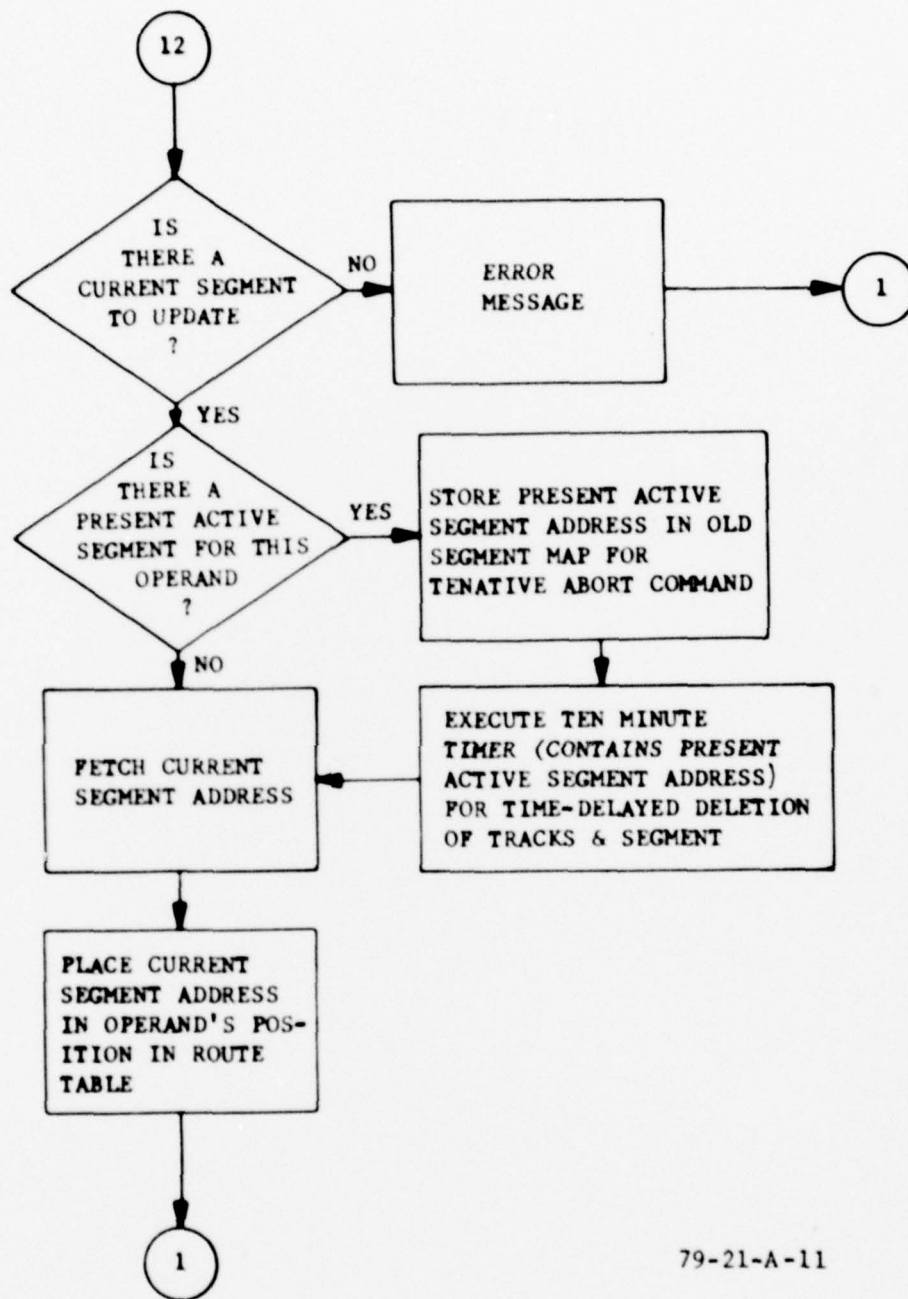

79-21-A-11