

AD-A077 116

ARMY ARMAMENT RESEARCH AND DEVELOPMENT COMMAND ABERD--ETC F/G 13/3
BLAST LOADING OF CONSTRUCTION MATERIALS AND CLOSURE DESIGNS.(U)
AUG 79 G A COULTER

UNCLASSIFIED

ARBRL-MR-02947

SBIE-AD-E430 325

NL

1 OF 2
AD-A077116

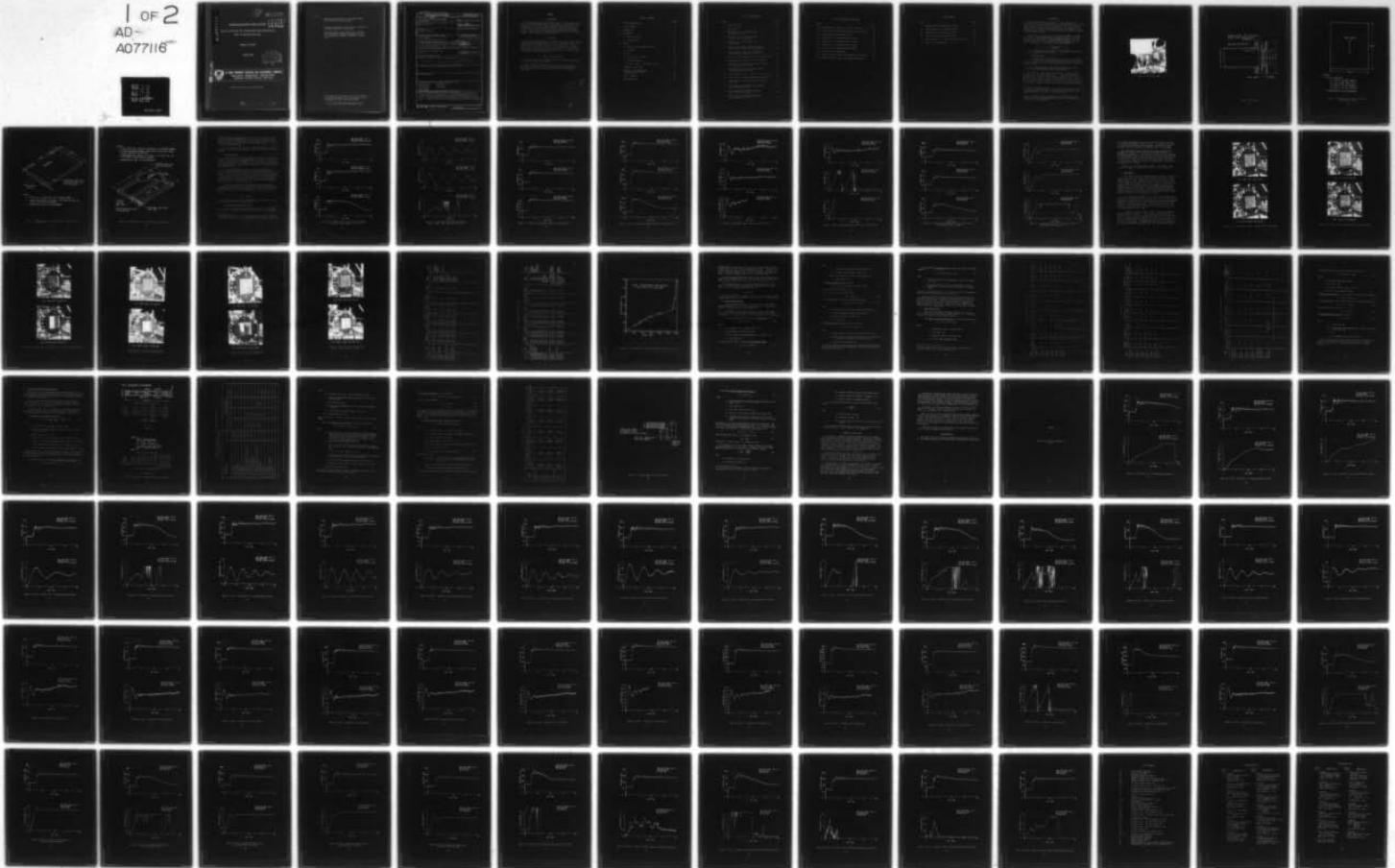

AD A 077116

(13)

AD-430 32

MEMORANDUM REPORT ARBRL-MR-02947

LEVEL

BLAST LOADING OF CONSTRUCTION MATERIALS
AND CLOSURE DESIGNS

George A. Coulter

August 1979

DDC
RECEIVED
NOV 23 1979
A

DDC FILE COPY



US ARMY ARMAMENT RESEARCH AND DEVELOPMENT COMMAND
BALLISTIC RESEARCH LABORATORY
ABERDEEN PROVING GROUND, MARYLAND

Approved for public release; distribution unlimited.

79 10 29 039

Destroy this report when it is no longer needed.
Do not return it to the originator.

Secondary distribution of this report by originating
or sponsoring activity is prohibited.

Additional copies of this report may be obtained
from the National Technical Information Service,
U.S. Department of Commerce, Springfield, Virginia
22151.

The findings in this report are not to be construed as
an official Department of the Army position, unless
so designated by other authorized documents.

*The use of trade names or manufacturers' names in this report
does not constitute endorsement of any commercial product.*

UNCLASSIFIED

SECURITY CLASSIFICATION OF THIS PAGE (When Data Entered)

REPORT DOCUMENTATION PAGE		READ INSTRUCTIONS BEFORE COMPLETING FORM
1. REPORT NUMBER MEMORANDUM REPORT ARBRL-MR-07947	2. GOVT ACCESSION NO.	3. RECIPIENT'S CATALOG NUMBER
4. TITLE (and Subtitle) Blast Loading of Construction Materials and Closure Designs	5. TYPE OF REPORT & PERIOD COVERED FINAL REPORT	
7. AUTHOR(s) George A. Coulter	6. CONTRACT OR GRANT NUMBER(s)	
9. PERFORMING ORGANIZATION NAME AND ADDRESS US Army Ballistic Research Laboratory ATTN: DRDAR-BLT Aberdeen Proving Ground, MD 21005	10. PROGRAM ELEMENT, PROJECT, TASK AREA & WORK UNIT NUMBERS Project Order No. DCPA 01-78-C-0247, Work Unit 1123-C	
11. CONTROLLING OFFICE NAME AND ADDRESS US Army Armament Research & Development Command US Army Ballistic Research Laboratory (DRDAR-BL) Aberdeen Proving Ground, MD 21005	12. REPORT DATE AUGUST 1979	13. NUMBER OF PAGES 103
14. MONITORING AGENCY NAME & ADDRESS (if different from Controlling Office) Defense Civil Preparedness Agency Washington, D.C. 20301	15. SECURITY CLASS. (of this report) UNCLASSIFIED	
16. DISTRIBUTION STATEMENT (of this Report) Approved for public release; distribution unlimited. <div style="display: flex; justify-content: space-around; align-items: center;"> <div style="border: 1px solid black; padding: 2px;">18 SBIE</div> <div style="border: 1px solid black; padding: 2px;">19 AD-E 430 325</div> <div style="border: 1px solid black; padding: 2px;">12/100</div> </div>		
17. DISTRIBUTION STATEMENT (of the abstract entered in Block 20, if different from Report)		
18. SUPPLEMENTARY NOTES		
19. KEY WORDS (Continue on reverse side if necessary and identify by block number) Basement Shelter Ultimate Failure Blast Closures Wood Beams Blast Loading Wood Panels Failure Load Plywood Panels		
20. ABSTRACT (Continue on reverse side if necessary and identify by block number) Results are presented for the blast loading of construction materials and closure designs for basement shelters. Blast loading histories and the corresponding panel displacements are presented for three types of closure designs: plywood sheet panels, wood beam panels, and plywood stressed skin panels. Ultimate failure loads were determined for the three closure designs.		

DD FORM 1 JAN 73 1073 EDITION OF 1 NOV 68 IS OBSOLETE

393 471

UNCLASSIFIED
SECURITY CLASSIFICATION OF THIS PAGE (When Data Entered)

SUMMARY

I. INTRODUCTION

The experiments reported here are a part of a study funded by the Defense Civil Preparedness Agency under project No. DCPA 01-78-C-0247, Work Unit 1123-C, entitled "Blast Loading in Existing Structures." The purpose of this part of the study was to determine the ultimate failure under air blast loads of construction materials and closure designs. Data are given for plywood sheets panels, wood closures, and plywood stressed skin panel closures (PSSP).

II. EXPERIMENT

Panels of sheet plywood (1.27 cm to 2.54 cm thickness) were simply supported at two ends and loaded by the blast at the end of the Ballistic Research Laboratory's 57.5 cm I.D. shock tube. A second and third series of tests were completed in a similar manner with wood beams made of 2x's placed flat, and the PSSP closures. Pressure-time loading and displacement histories were measured as a function of the blast wave for the different closures.

III. RESULTS AND CONCLUSIONS

Records of blast wave loading and panel displacement are presented as plots in the body of this report.

Panel displacement amplitudes and frequencies are presented as a function of closure type. The loads needed for ultimate failure of the closures exposed to blast was about 4-20 times the allowable static load.

Accession For	
NTIS GRA&I	<input checked="" type="checkbox"/>
DOC TAB	<input type="checkbox"/>
Unannounced	<input type="checkbox"/>
Justification	<input type="checkbox"/>
By _____	
Distribution/	
Availability Codes	
Dist	Avail and/or special
A	

TABLE OF CONTENTS

	Page
LIST OF ILLUSTRATIONS	7
LIST OF TABLES	9
I. INTRODUCTION	11
II. EXPERIMENT	11
A. Shock Tube Setup	11
B. Instrumentation	17
III. RESULTS	17
A. Pressure and Displacement Traces	17
B. Data Table	26
IV. ANALYSIS	36
A. Plywood Sheet Closures	36
B. Wood Beam Closures	38
C. Plywood Stressed - Skin Panel Closures	43
V. SUMMARY AND CONCLUSIONS	51
APPENDIX - PRESSURE-TIME AND DISPLACEMENT-TIME TRACES	53
LIST OF SYMBOLS	97
DISTRIBUTION LIST	99

LIST OF ILLUSTRATIONS

Figure	Page
1. Shock Tube setup	12
2. Panel holder	13
3. DCPA panel test, 57.5 cm shock tube - plywood sheet closure	14
4. DCPA panel test, 57.5 cm shock tube - closure of 2x's placed flat	15
5. DCPA panel test, 57.5 cm shock tube - PSSP closure	16
6. Pressure-time loading records for plywood sheet closures simply supported at two ends	18
7. Displacement-time records for plywood sheet closures simply supported at two ends	19
8. Pressure-time loading records for 2x's placed flat	20
9. Displacement-time records for 2x's placed flat	22
10. Pressure-time loading records for PSSP closures with plywood skins not glued	24
11. Displacement-time records for PSSP closures with plywood skins not glued	25
12. Plywood sheet closures - load of 28.7 kPa (4.16 psi)	27
13. Plywood closures showing different plywood grades	28
14. Closure from 2x's placed flat-load of 589 kPa (85.4 psi)	29
15. PSSP closures with plywood skins not glued - load of 149 kPa (21.7 psi)	30
16. PSSP closures with plywood skins glued - load of 163 kPa (23.7 psi)	31
17. PSSP closures with plywood skins glued - load of 187 kPa (27.2 psi)	32

LIST OF ILLUSTRATIONS (CONTINUED)

Figure	Page
18. Displacement as a function of load for flat 2x's	35
19. Neutral axis for deflection and EI_g for PSSP closure	44
20. Rolling shear critical plane and Q_s	49
A-1. Records for 1.27 cm plywood sheet closures	55
A-2. Records for 1.59 cm plywood sheet closures	59
A-3. Records for 1.90 cm plywood sheet closures	64
A-4. Records for 2.54 cm plywood sheet closures	68
A-5. Records for 2x's placed flat	72
A-6. Records for PSSP closures with plywood skins not glued	85
A-7. Records for PSSP closures with plywood skins glued	91

LIST OF TABLES

Table	Page
I. Loading Data for Plywood Sheet Closures	33
II. Loading Data for 2x's and PSSP Closures	34
III. Properties for the Wood Test Closures	39
IV. Predicted Values for Ultimate Failure	41
V. Basic Spacing, b, for Various Plywood Thicknesses . . .	45
VI. A and y' for Computing Q_s	48

I. INTRODUCTION

The work reported here is a part of a task at the Ballistic Research Laboratory (BRL) funded by the Civil Preparedness Agency (DCPA) under project Order No. DCPA 01-78-C-0247, Work Unit 1123-C entitled "Blast Loading in Existing Shelter Structures." The purpose of the present work is to verify the prediction of the loads needed to cause ultimate failure (breakout) in predesigned closures intended to upgrade existing basement shelters.¹

Three kinds of closures were to be tested to breakout: plywood sheet panels, wood beam closures (2x's placed flatwise), and plywood stressed skin panels (PSSP). The test procedure used was to blast load the simply supported closures at the end of the shock tube until breakout occurred. The experimental setup is described below.

II. EXPERIMENT

The shock tube, panel test fixture, and recording instrumentation are briefly described in this section.

A. Shock Tube Setup

A panel holder was constructed for use at the end of the BRL 57.5 cm I. D. shock tube. The test fixture which had been used to hold the plywood panels in the previously reported experiments² was modified for these tests.

Figure 1 shows the panel holder at the end of the shock tube; Figure 2 shows some additional details of the setup.

Each panel was simply supported at two ends. Figures 3-5 show the panel sizes and construction details. To allow free movement through the 47 cm square opening, a small clearance of 0.315 cm was allowed on the long sides, between the panel and the holder. A strip of 0.317 cm thick rubber was attached to the holder on each side so as to overlap the clearance openings. The rubber was left loose at each side of the test panels and could move freely with the panel when blast

¹H.L. Murphy, "Upgrading Basements for Combined Nuclear Weapon Effects: Predesigned Expedient Options," Technical Report SRI Project 5622, Stanford Institute, Menlo Park, CA94025, October 1977.

²George A. Coulter, "Debris Hazard from Blast Loaded Plywood Sheet Closures," Memorandum Report ARBRL-MR-02917, Ballistic Research Laboratory March 1979. (AD #A071460)

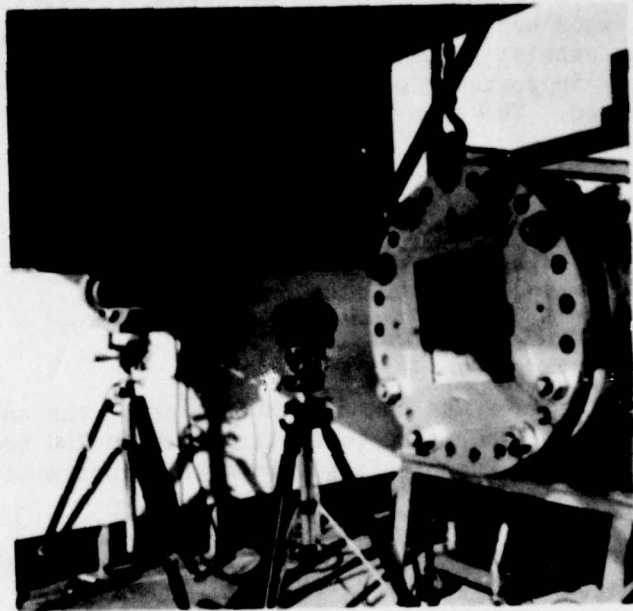

Figure 1. Shock tube setup

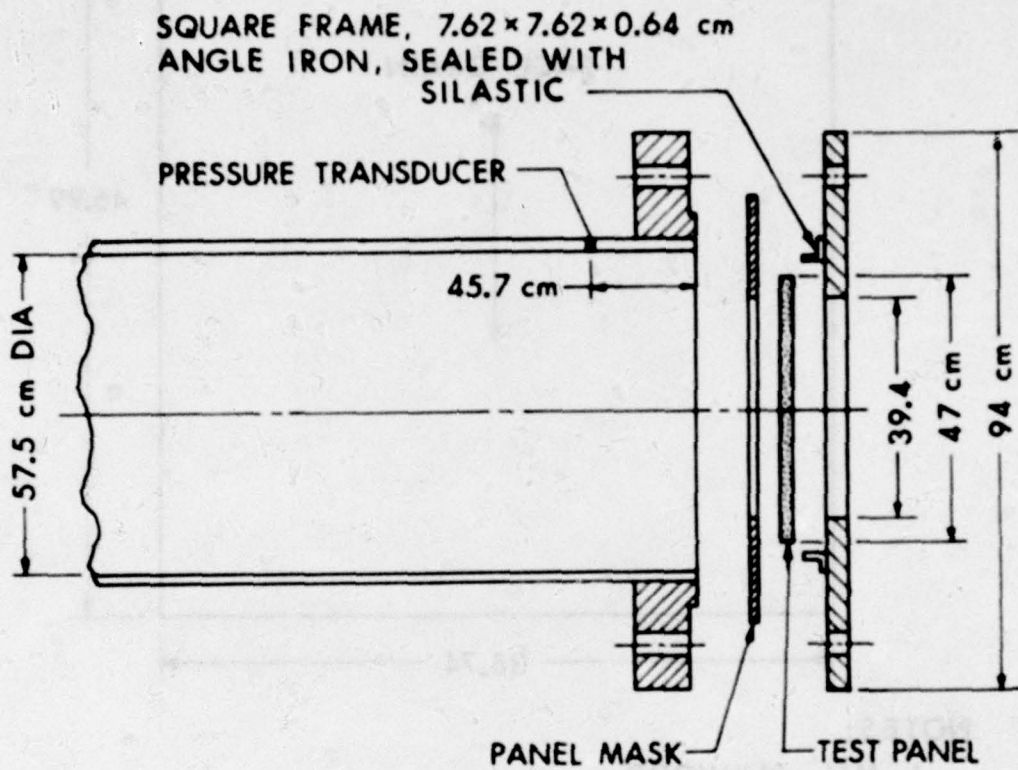
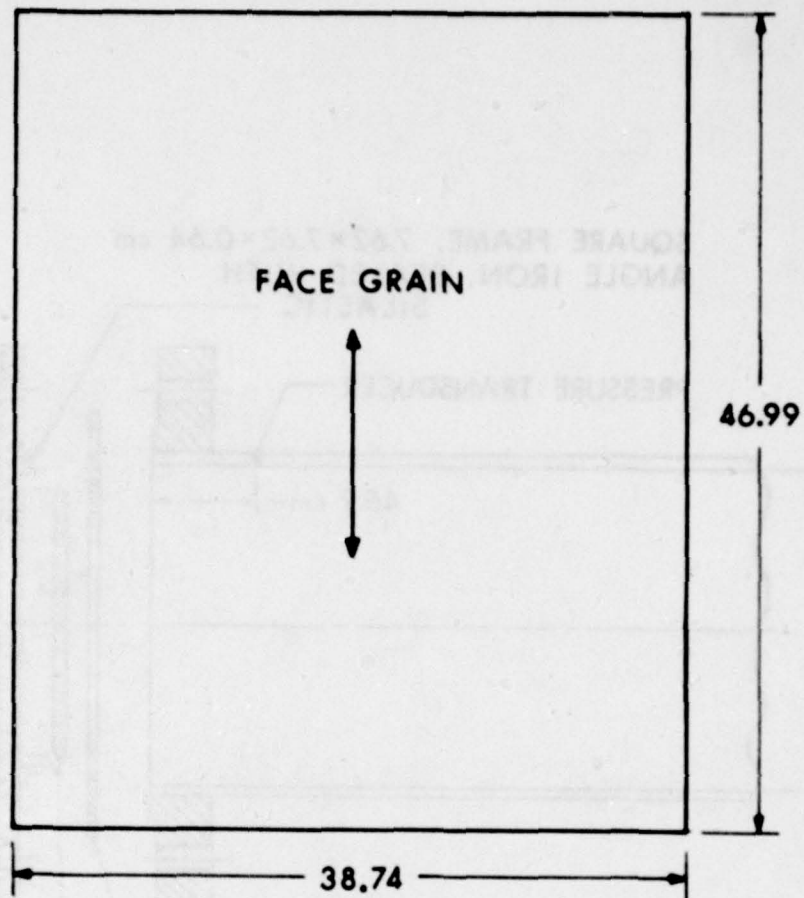

Figure 2. Panel holder



NOTES:

1. MTL - PLYWOOD

- (a) 1.27 cm AD EXT GROUP 1
- (b) 1.59 cm BB CLASS 1 EXT
- (c) 1.90 cm AC EXT GROUP 1
- (d) 2.54 cm AC EXT GROUP 1

2. DIMENSIONS IN CENTIMETRES

Figure 3. DCPA panel test, 57.5 cm shock tube-
plywood sheet closure

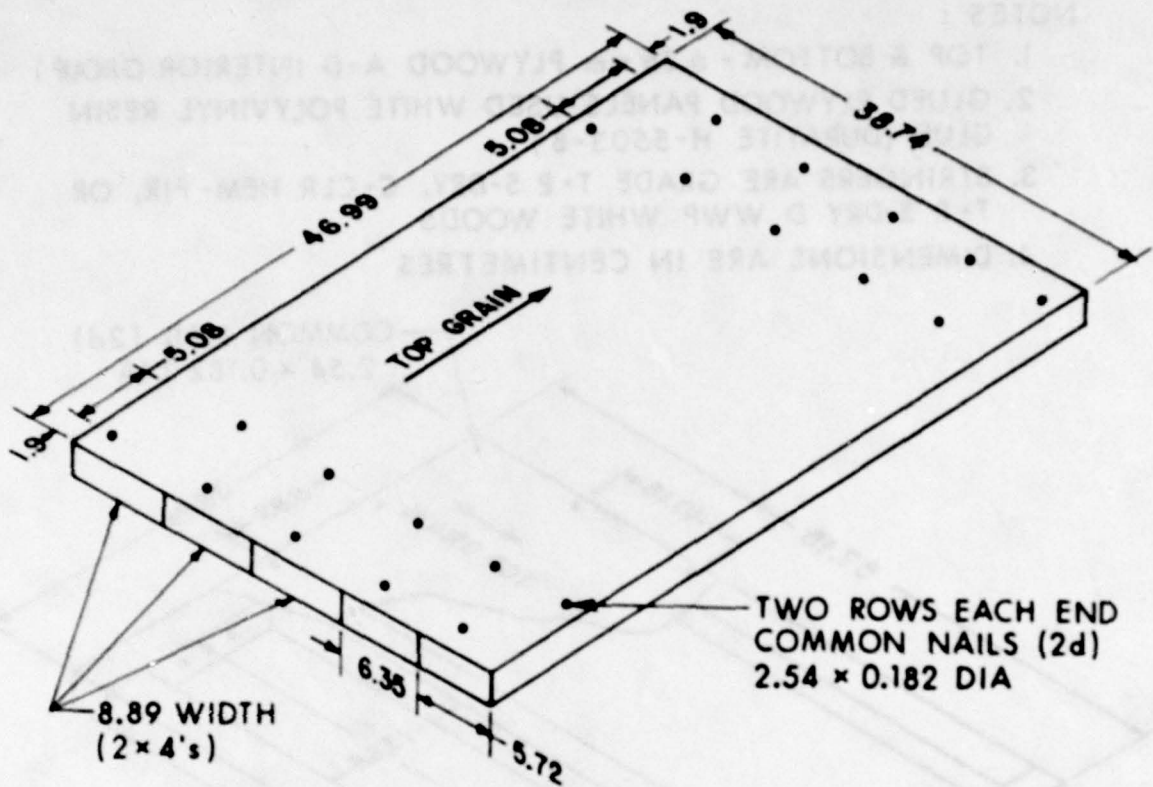

NOTES:

1. TOP-6.35 mm PLYWOOD A-D INTERIOR GROUP 1
2. 2x4's ARE GRADE T·P S-DRY, C-CLR HEM-FIR, OR T·P S-DRY D WWP WHITE WOODS
3. DIMENSIONS ARE IN CENTIMETRES

Figure 4. DCPA panel test, 57.5 cm shock tube - closure of 2x's placed flat

NOTES :

1. TOP & BOTTOM - 6.35 mm PLYWOOD A-D INTERIOR GROUP 1
2. GLUED PLYWOOD PANELS USED WHITE POLYVINYL RESIN GLUE (DURATITE H-5503-B)
3. STRINGERS ARE GRADE T·P S-DRY, C-CLR HEM-FIR, OR T·P S-DRY D WWP WHITE WOODS
4. DIMENSIONS ARE IN CENTIMETRES

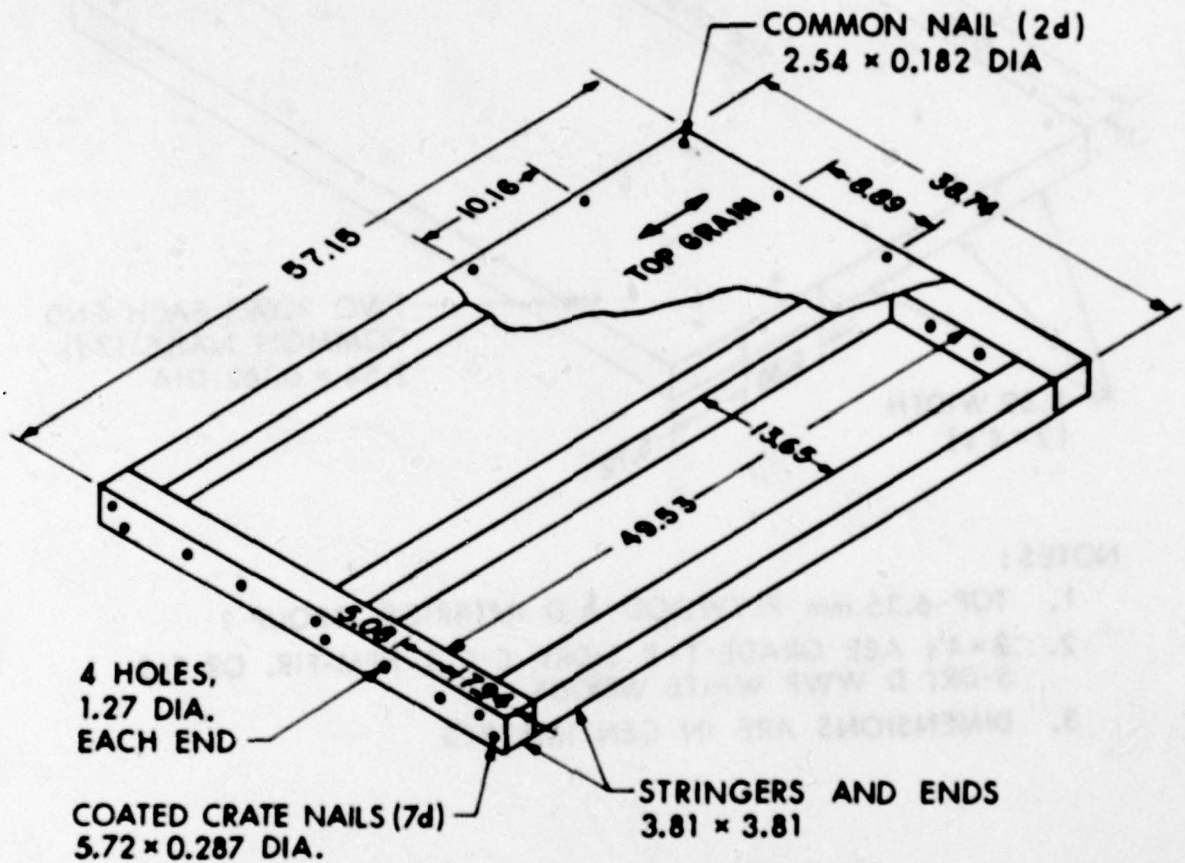

Figure 5. DCPA panel test, 57.5 cm shock tube - PSSP closure

loaded. Two small finishing nails (1.44 mm dia x 38.1 mm long - 4d) were driven into the bottom of the panels to assure the proper stand-off (1.27 cm or 0.64 cm depending on the test panel length). Rubber bands were used to hold the panel in contact with the holder to assure no air loss during loading.

The test setup was completed with a high speed camera, pressure transducer, and displacement follower. These are described in Section B below.

B. Instrumentation

The pressure recording consisted of a PCB Model 113 M 28 quartz transducer with a built-in voltage amplifier. The signal from the transducer was recorded by an FM Honeywell 7600 tape recorder. A quick-look oscillograph playback was available at the test site to view the records until the analog data could be converted to digital, and be plotted with engineering units.

The displacement data was acquired with an OPTRON Model 501 Electro Optical Displacement Follower³. A small black balsa wood target, glued to outside of the panel, was tracked with the displacement follower. The optical target image was converted to an electron image in which the electron density was proportional to the corresponding light (from target) intensity. Again the electrical output signal was recorded by the 7600 FM tape machine. The data reduction method was the same as that for the pressure records.

A high speed camera (Red Lakes Hycam) running at 5000 pps completed the instrumentation. During the tests the lighting was found to be inadequate for the desired framing rate. Therefore, the camera was not used after the initial checkout shots and no prints will be shown.

III. RESULTS

The results are presented in two sections: The pressure loading and displacement traces, and a summary data table.

A. Pressure and Displacement Traces

A typical series of loading and deflection records are shown in Figures 6-11. The pressure-time records show the input shock wave

³ See company manual "Model 501 Optical Displacement Follower," OPTRON, Division of Univ. Tech. Inc., 30 Hazel Terrace, Woodbridge, Conn. 06525.

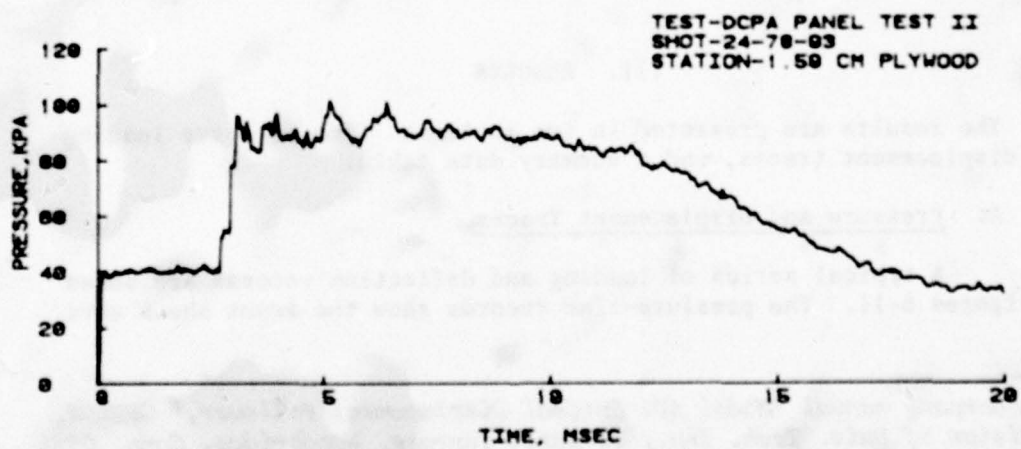
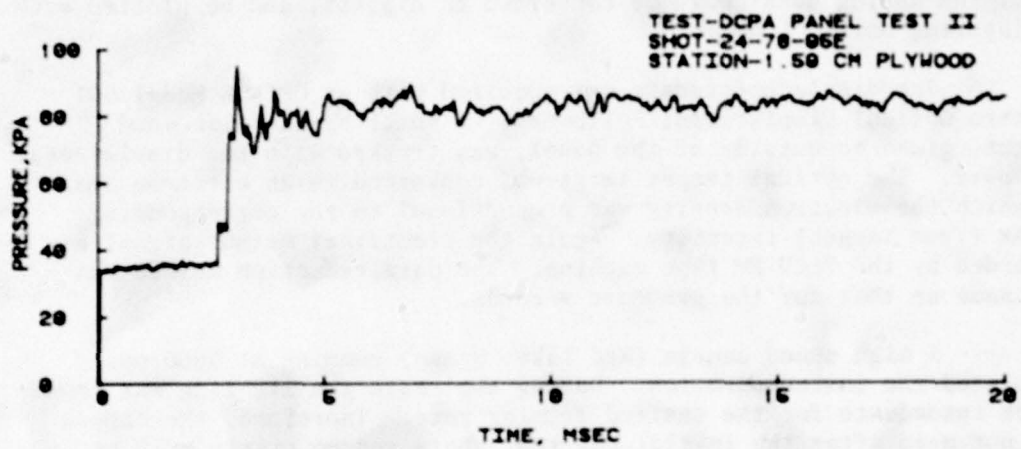
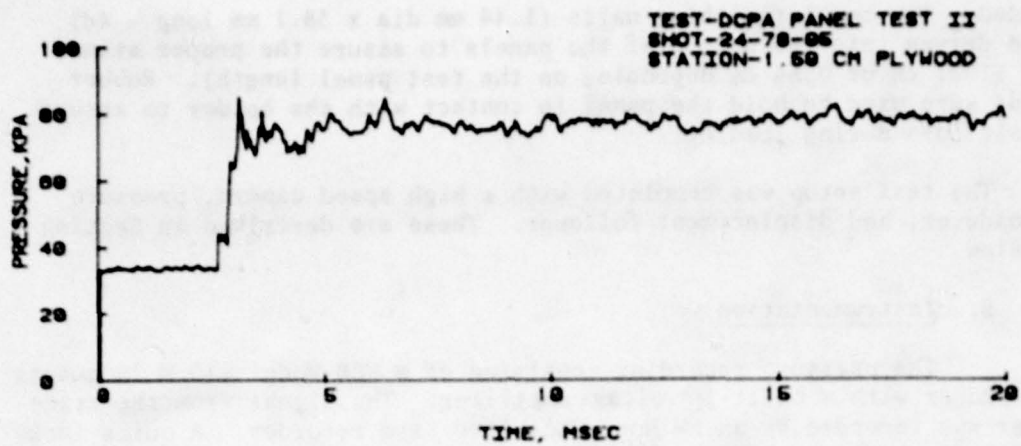

Figure 6. Pressure-time loading records for plywood sheet closures simply supported at two ends

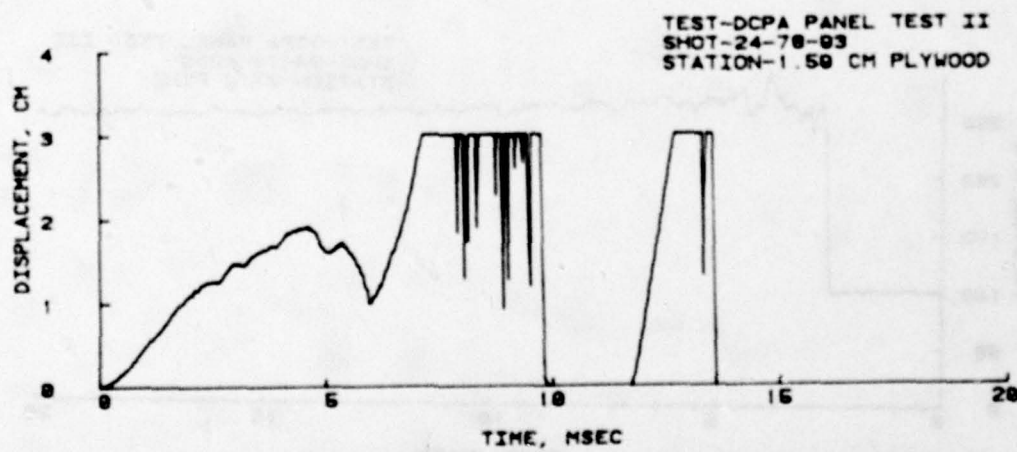
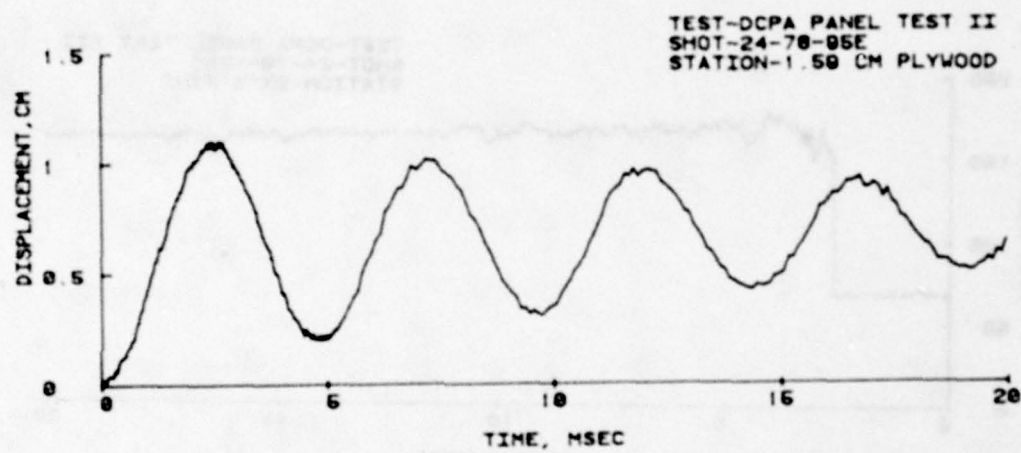
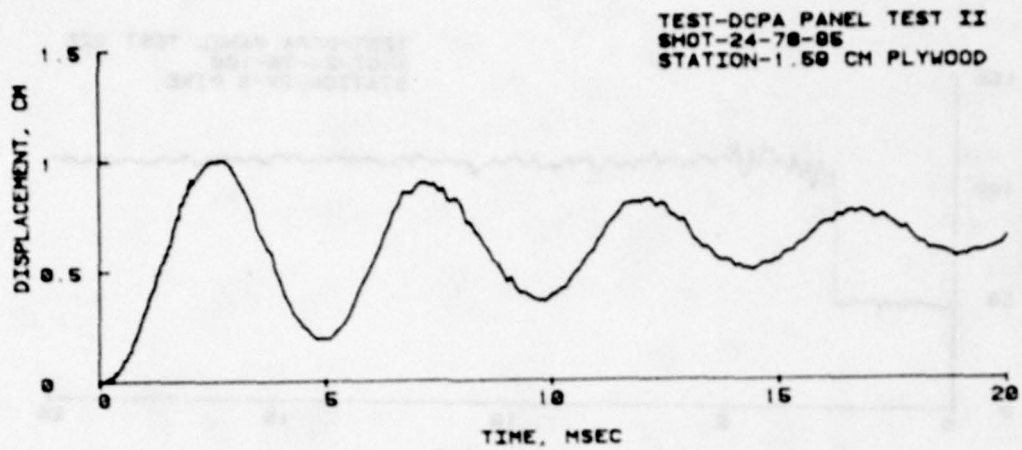

Figure 7. Displacement-time records for plywood sheet closures simply supported at two ends

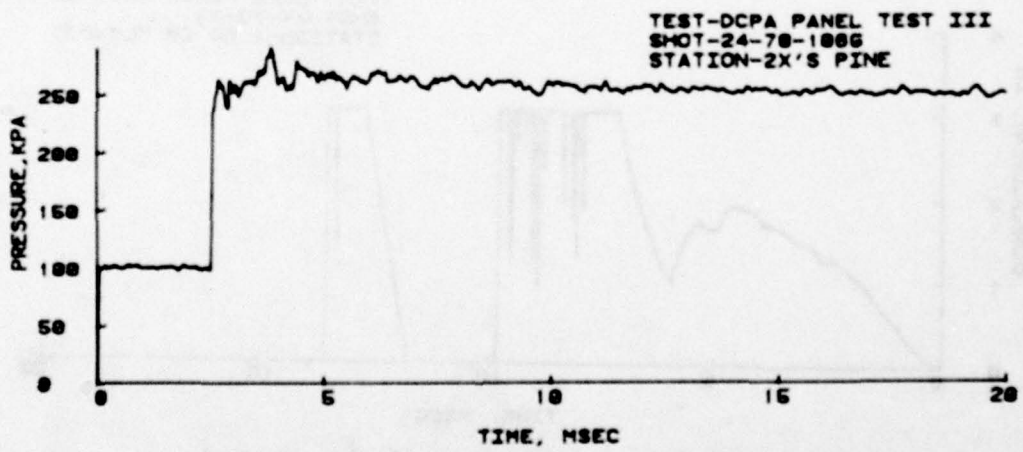
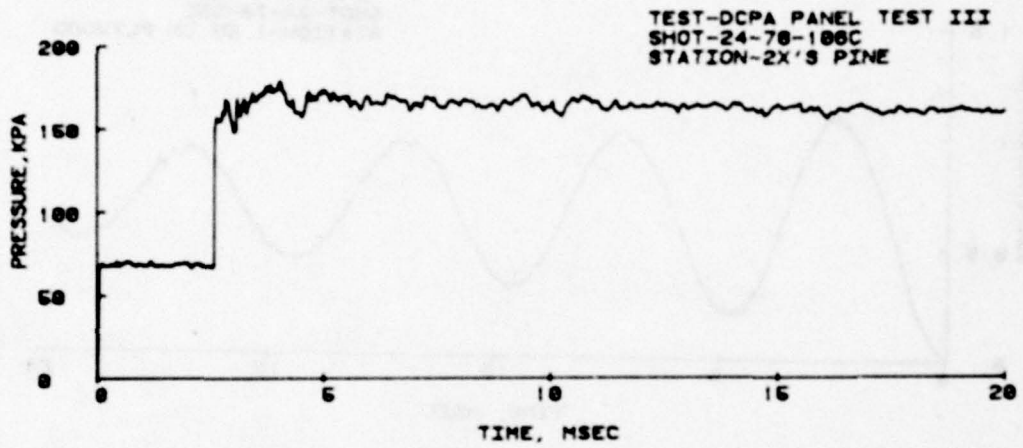
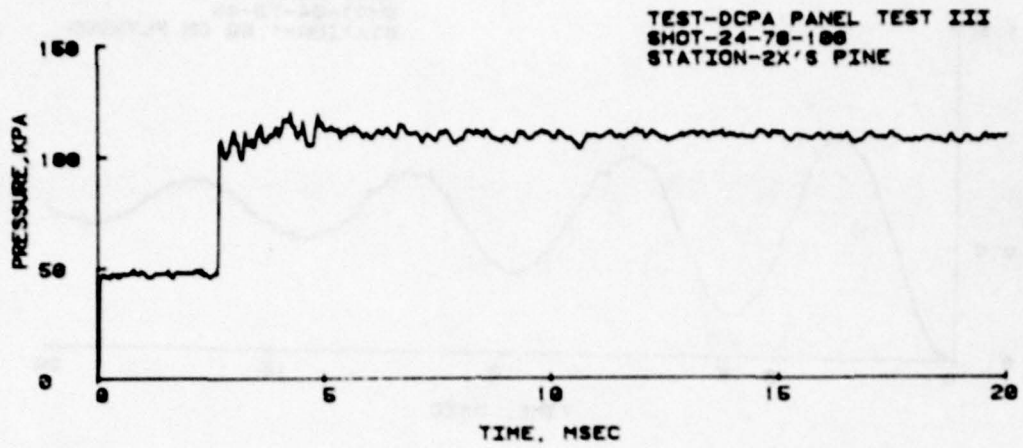

Figure 8. Pressure-time loading records for 2x's placed flat

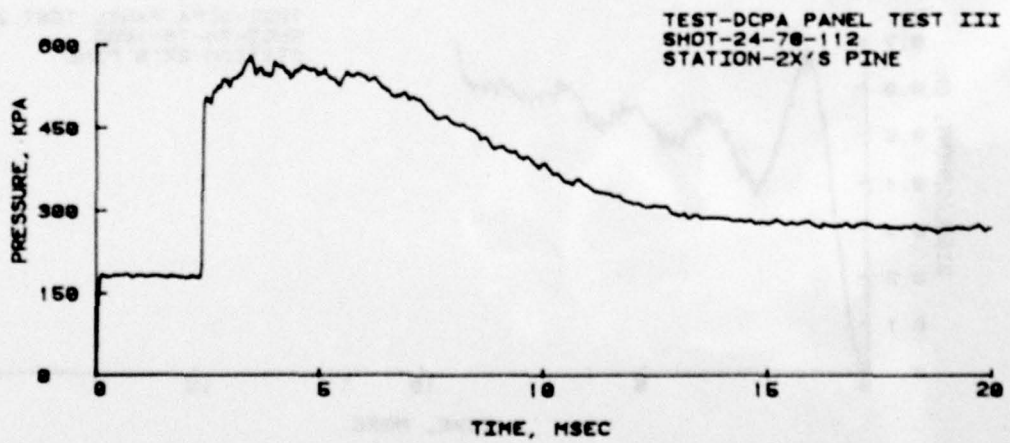
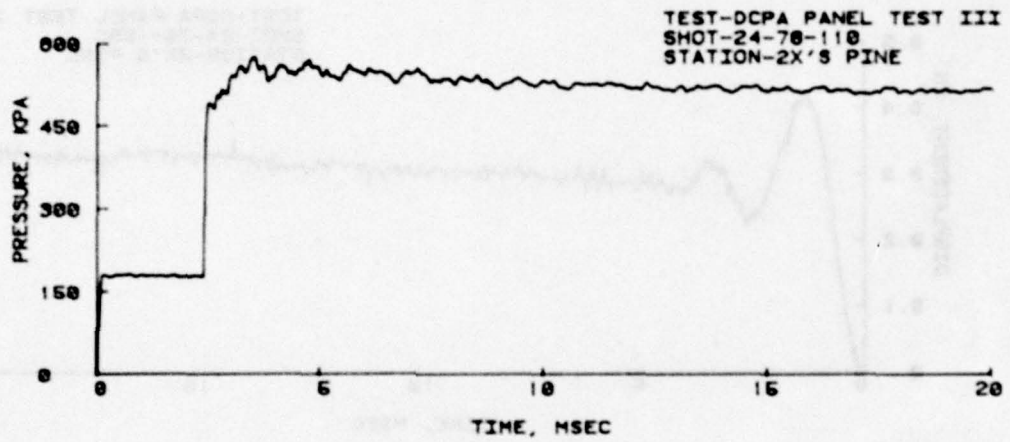
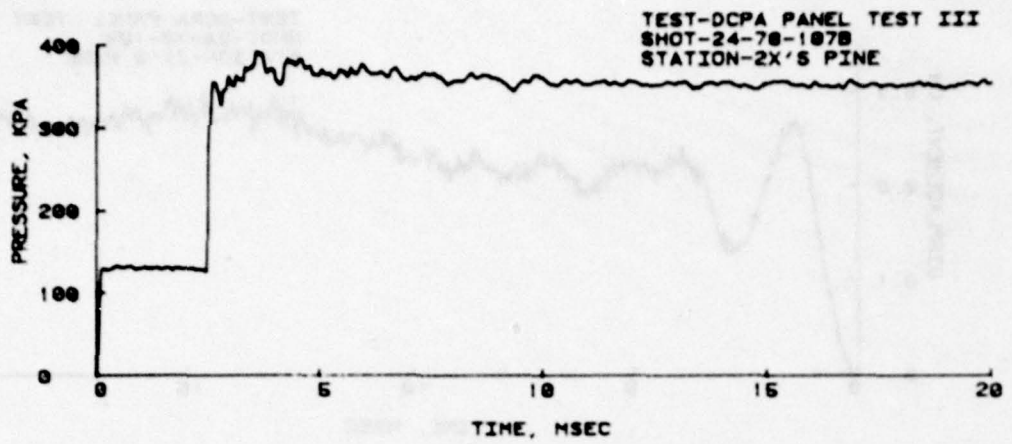

Figure 8. (Cont) Pressure-time loading records for 2x's placed flat

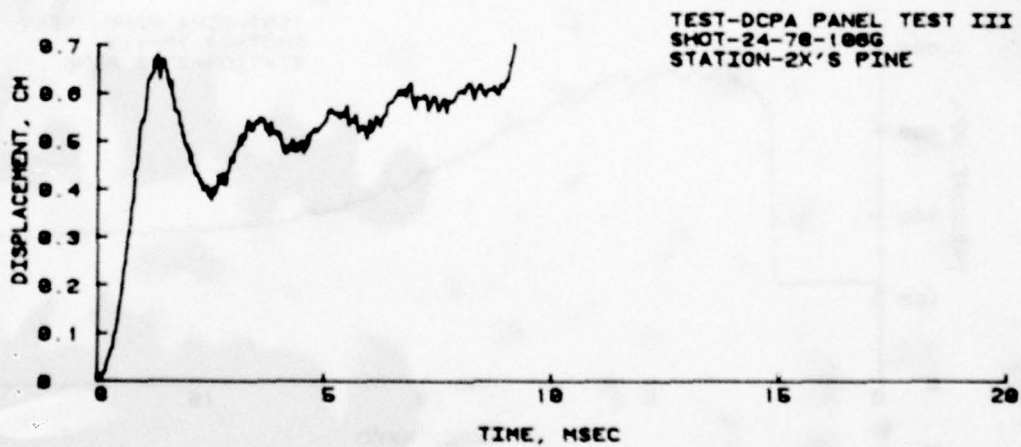
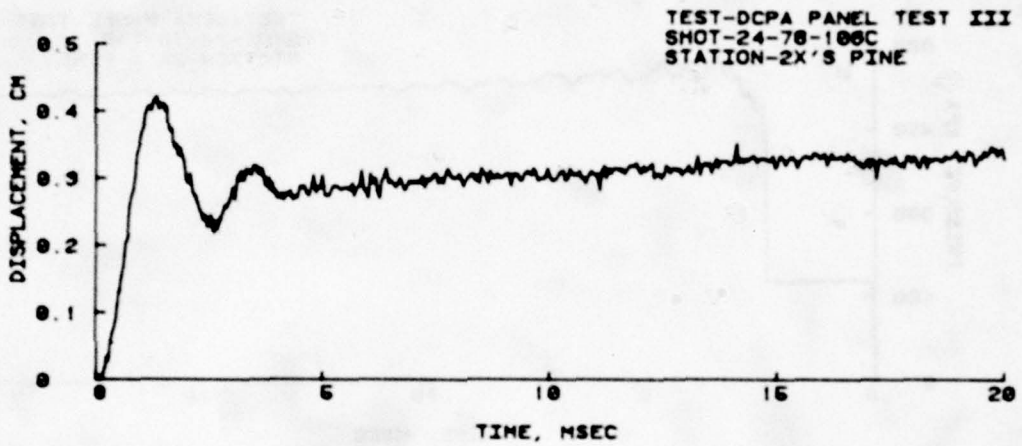
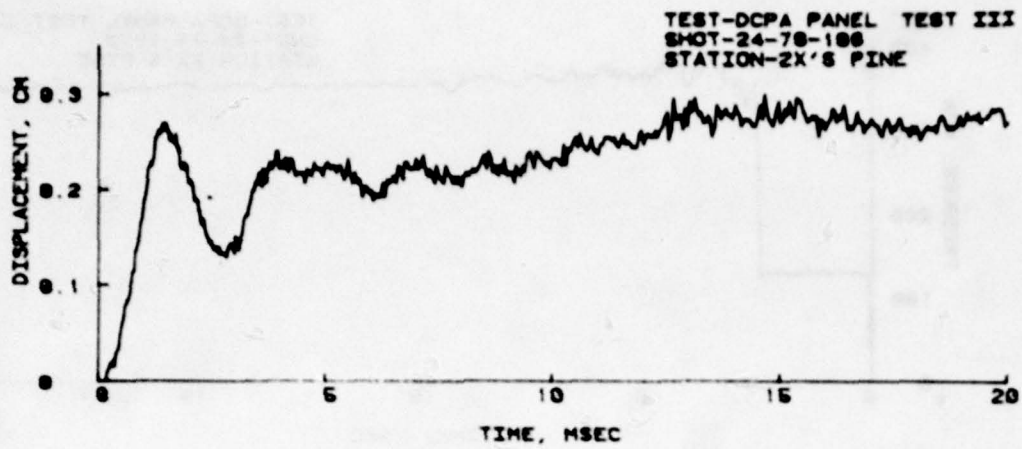

Figure 9. Displacement-time records for 2x's placed flat

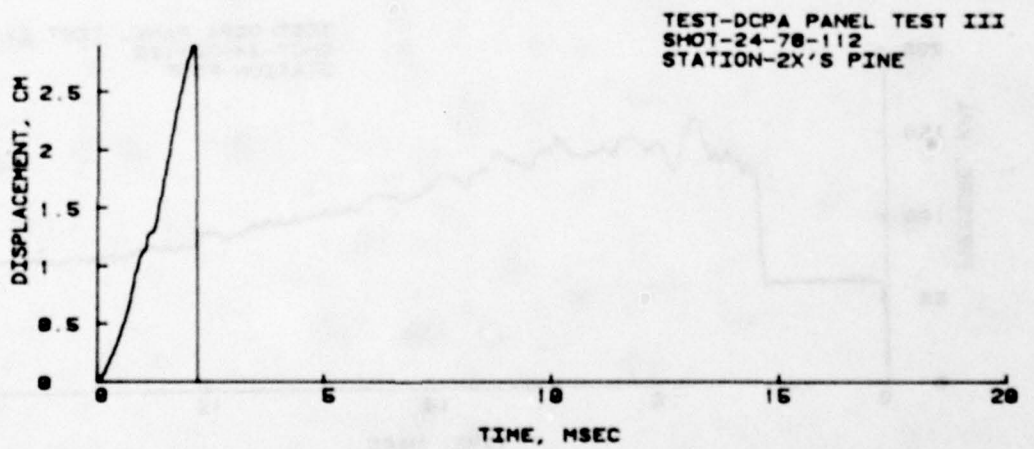
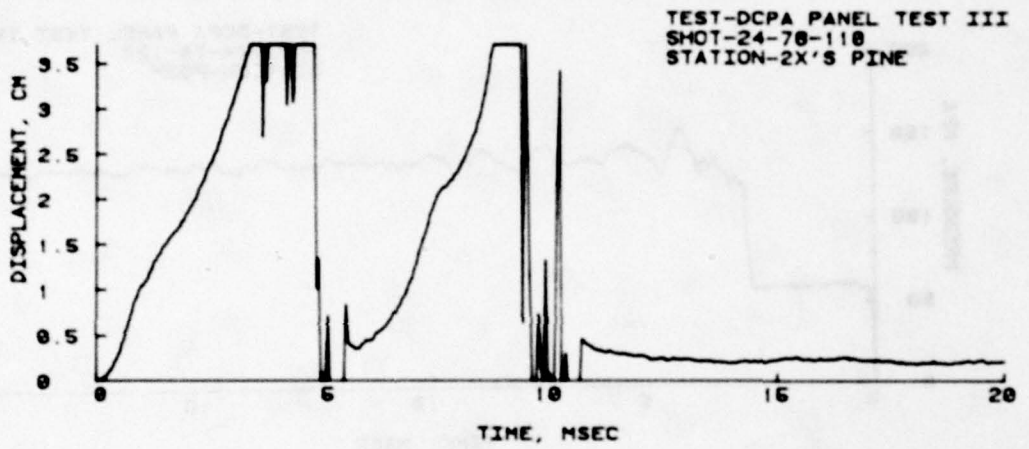
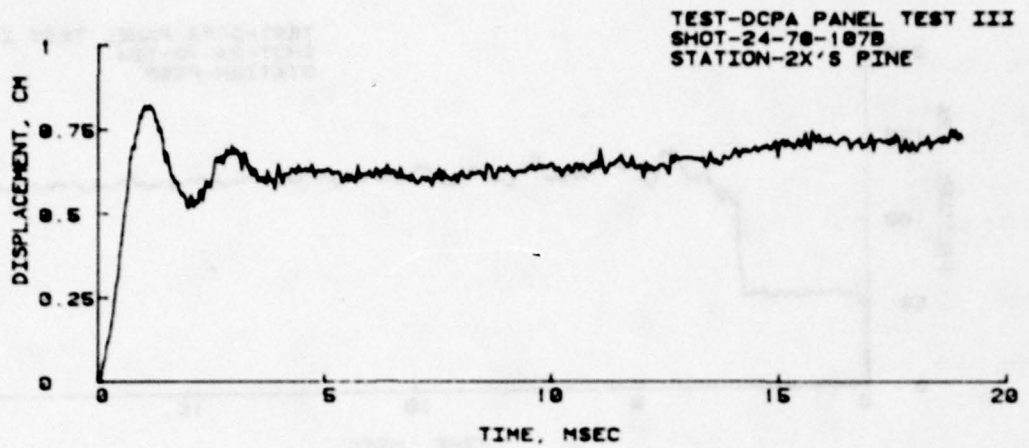

Figure 9. (Cont) Displacement-time records for 2x's placed flat

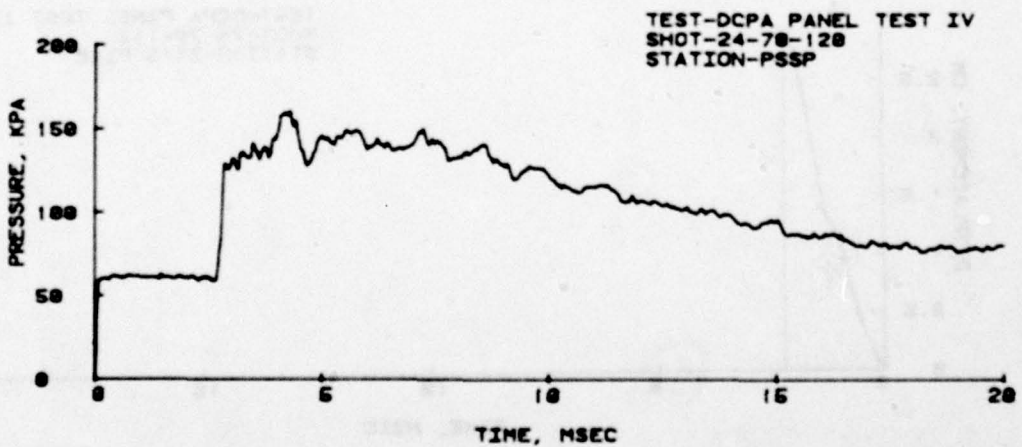
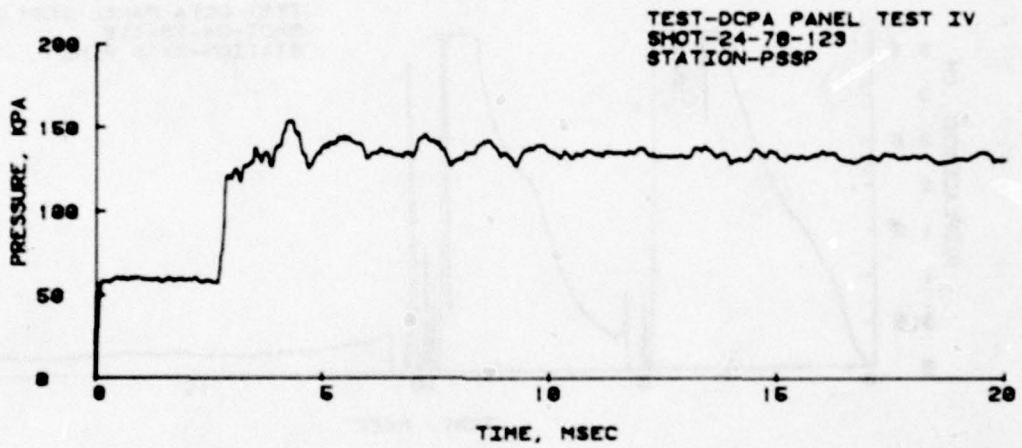
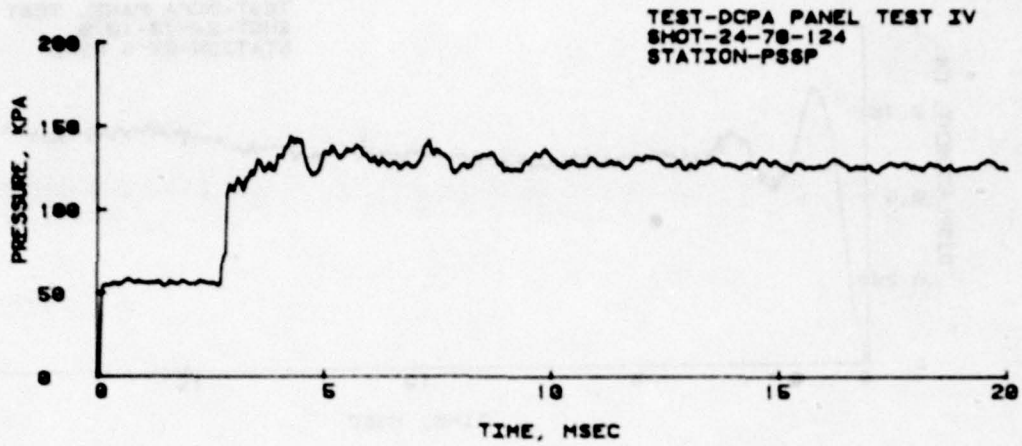

Figure 10. Pressure-time loading records for PSSP closures with plywood skins not glued

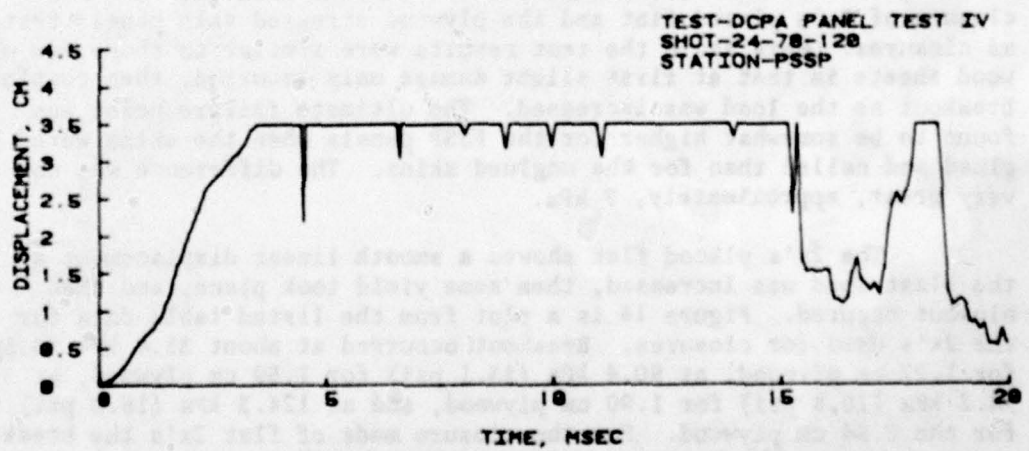
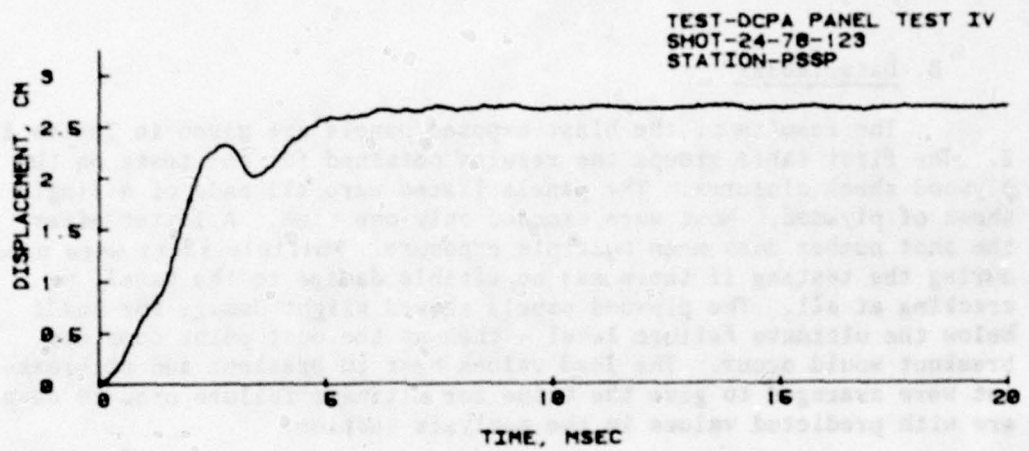
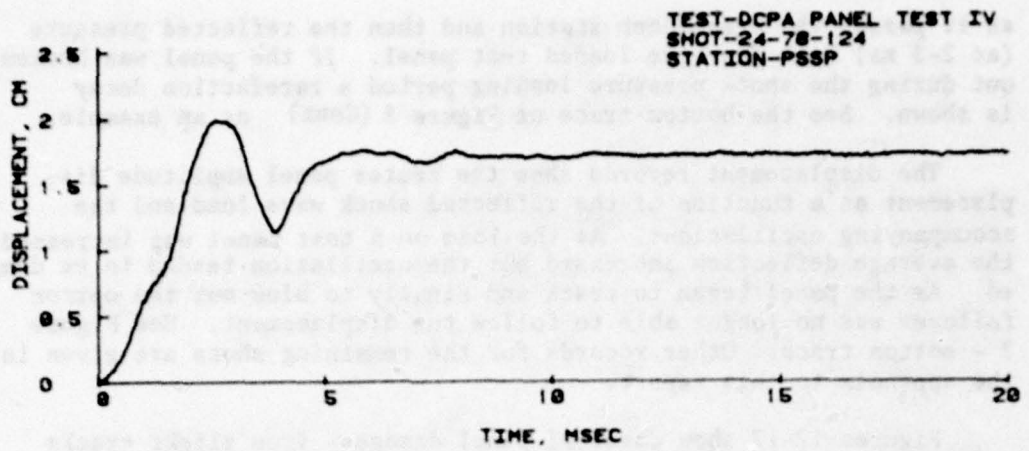

Figure 11. Displacement-time records for PSSP closures with plywood skins not glued

as it passes the transducer station and then the reflected pressure (at 2-3 ms) back from the loaded test panel. If the panel was broken out during the shock pressure loading period a rarefaction decay is shown. See the bottom trace of Figure 8 (Cont) as an example.

The displacement records show the center panel amplitude displacement as a function of the reflected shock wave load and the accompanying oscillations. As the load on a test panel was increased, the average deflection increased but the oscillation tended to be damped. As the panel began to crack and finally to blow out the optron follower was no longer able to follow the displacement. See Figure 7 - bottom trace. Other records for the remaining shots are given in the appendix to this report.

Figures 12-17 show cases of panel damage - from slight cracks as shown in Figure 12 to near total blow-out as seen in Figure 15.

B. Data Tables

The results of the blast exposed panels are given in Tables 1 and 2. The first table groups the results obtained for the tests on the plywood sheet closures. The panels listed were all made of a single sheet of plywood. Most were exposed only one time. A letter after the shot number does mean multiple exposure. Multiple shots were used during the testing if there was no visible damage to the panel, no cracking at all. The plywood panels showed slight damage for loads below the ultimate failure level - then at the out point complete breakout would occur. The load values near to breakout and at breakout were averaged to give the value for ultimate failure used to compare with predicted values in the analysis section.

The second table summarizes the results from the wood beam closure of 2x's placed flat and the plywood stressed skin panels tested as closures. Here again the test results were similar to those for plywood sheets in that at first slight damage only occurred, then complete breakout as the load was increased. The ultimate failure point was found to be somewhat higher for the PSSP panels when the skins were glued and nailed than for the unglued skins. The difference was not very great, approximately, 7 kPa.

The 2x's placed flat showed a smooth linear displacement as the blast load was increased, then some yield took place, and then blowout occurred. Figure 18 is a plot from the listed table data for the 2x's used for closures. Breakout occurred at about 31.4 kPa (4.5psi) for 1.27 cm plywood, at 90.4 kPa (13.1 psi) for 1.59 cm plywood, at 74.2 kPa (10.8 psi) for 1.90 cm plywood, and at 124.3 kPa (18.0 psi) for the 2.54 cm plywood. For the closure made of flat 2x's the breakout occurred at about 488 kPa (70.8 psi). The PSSP closures blowout

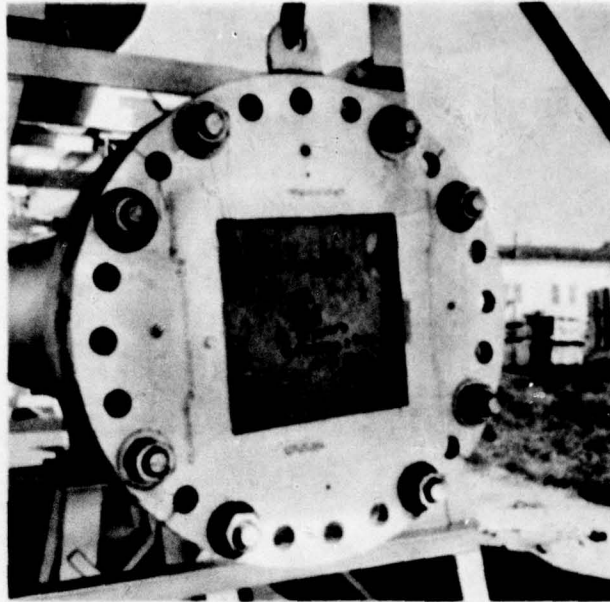

(A) PRE-SHOT 24-78-82

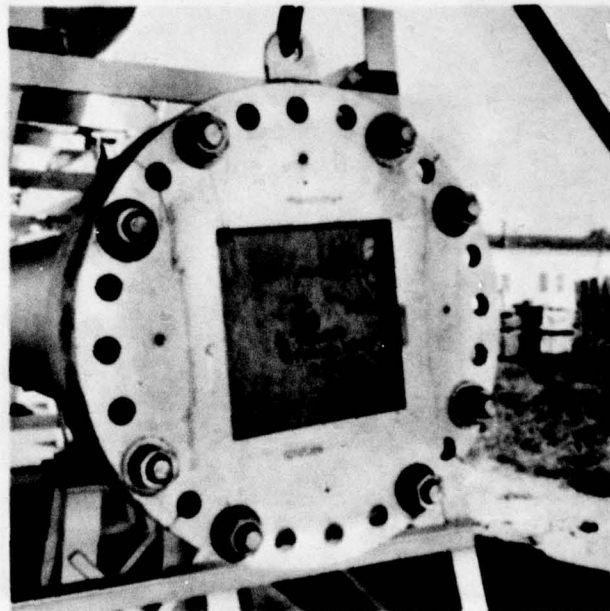

(B) POST-SHOT 24-78-82

Figure 12. Plywood sheet closures - load of 28.7 kPa (4.16 psi)

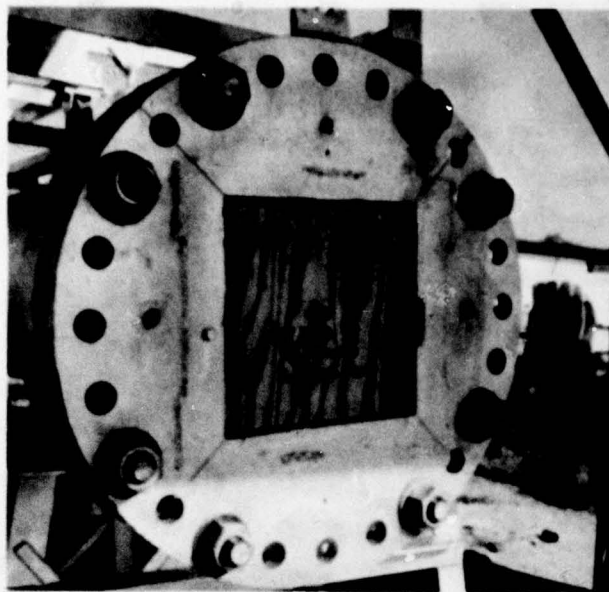

(A) 1.59 cm PLYWOOD

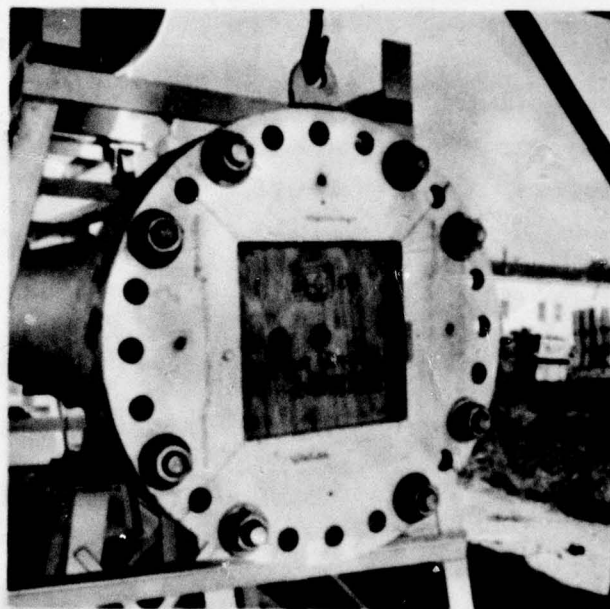

(B) 1.90 cm PLYWOOD

Figure 13. Plywood closures showing different plywood grades

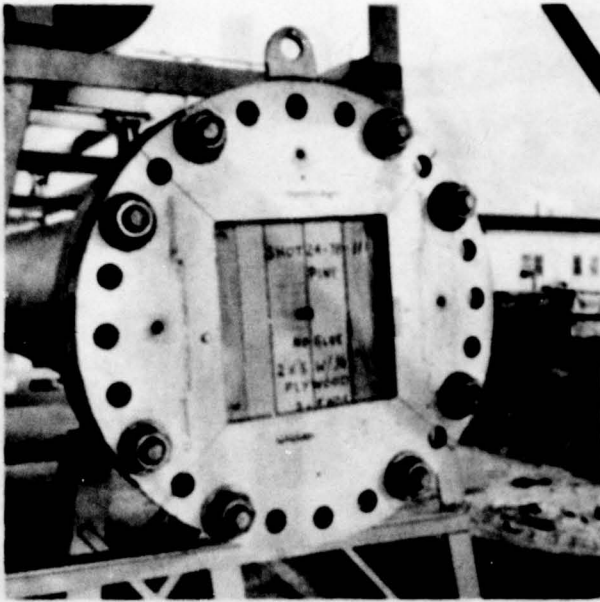

(A) PRE-SHOT 24-78-111

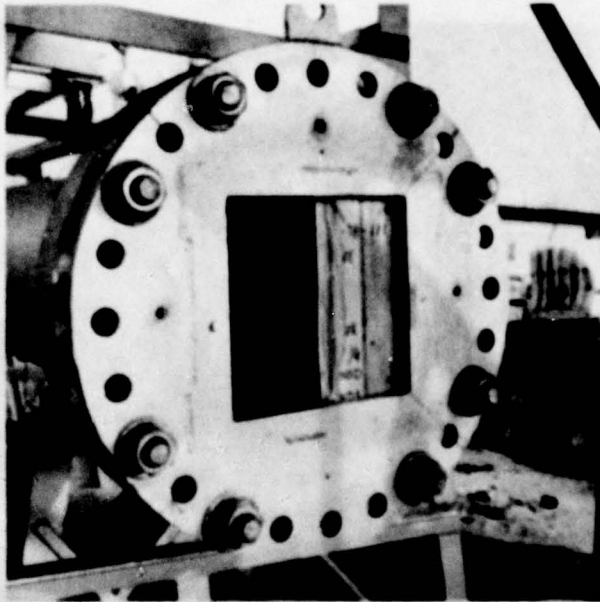

(B) POST-SHOT 24-78-111

Figure 14. Closure from 2x's placed flat - load of 589 kPa (85.4 psi)

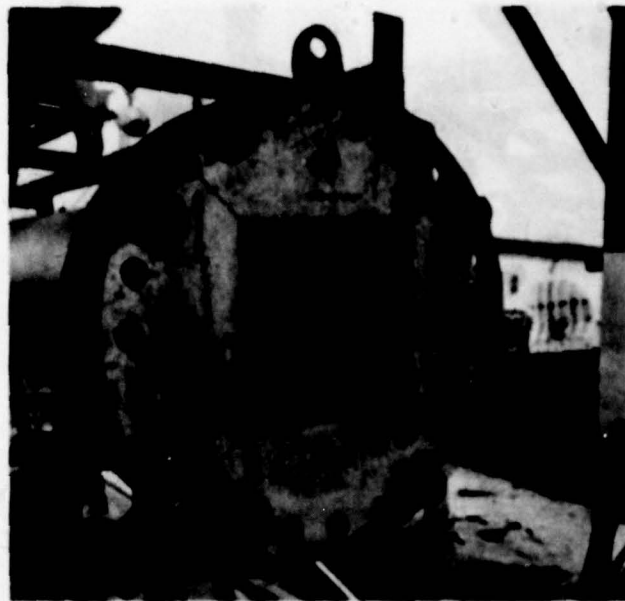

(A) PRE-SHOT 24-78-120

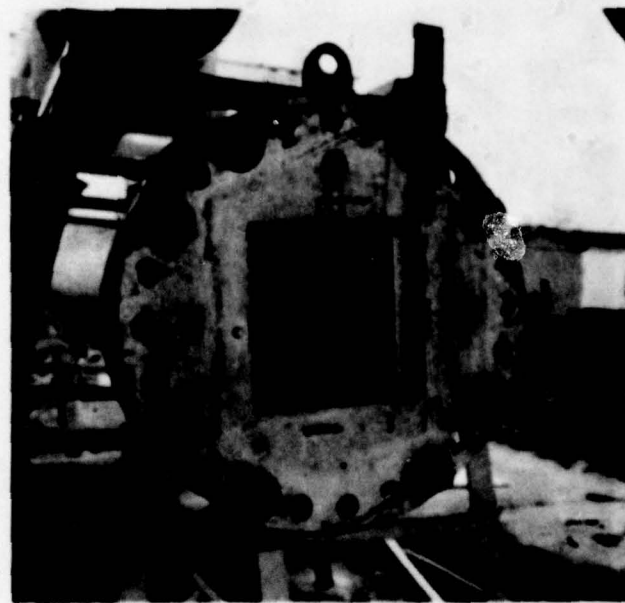

(B) POST-SHOT 24-78-120

Figure 15. PSSP closures with plywood skins
not glued - load of 149 kPa (217 psi)

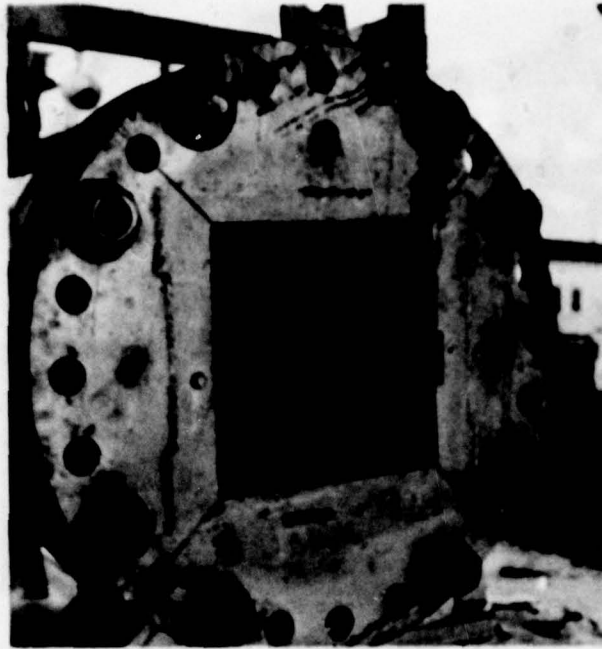

(A) PRE-SHOT 24-78-118A

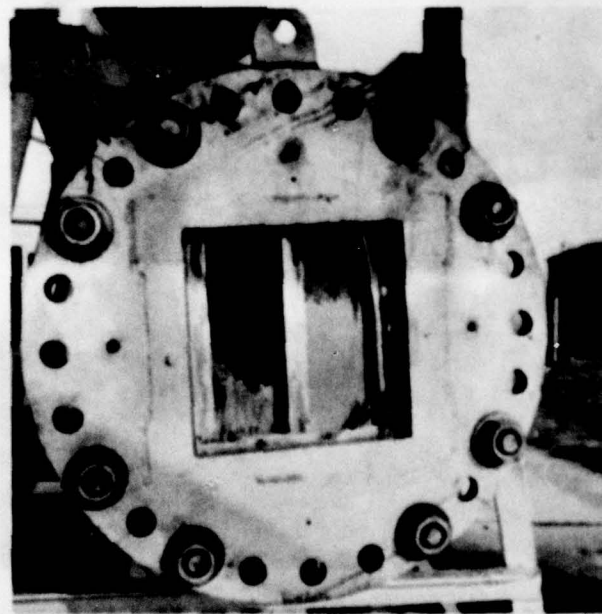

(B) POST-SHOT 24-78-118A

Figure 16. PSSP closures with plywood skins
glued-loads of 163 kPa (23.7 psi)

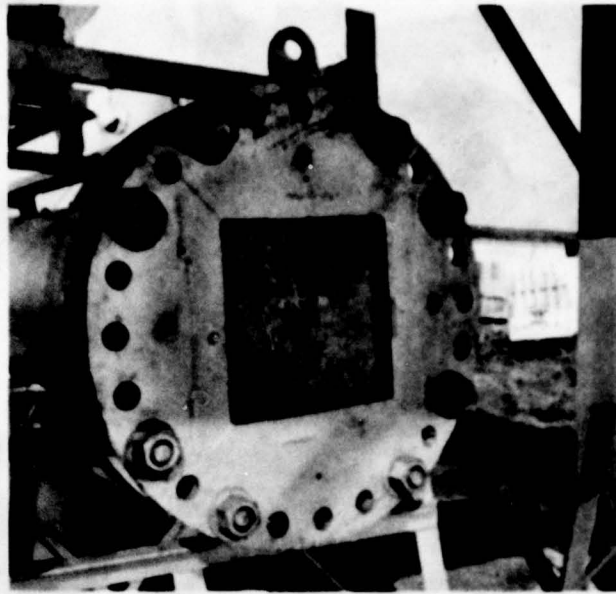

(A) PRE-SHOT 24-78-115

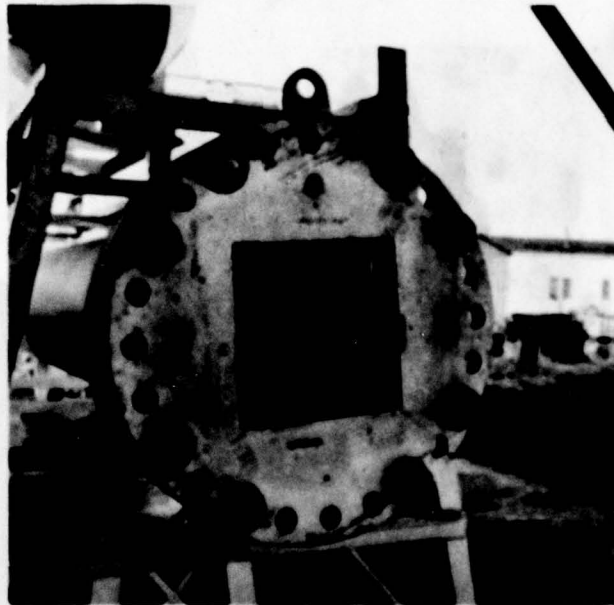

(B) POST-SHOT 24-78-115

Figure 17. PSSP closure with plywood skins
glued - load of 187 kPa (27.2 psi)

Table 1. Loading Data for Plywood Sheet Closures

SHOT NO.	TYPE PANEL	AMBIENT PRESSURE kPa	SHOCK OVERPRESSURE kPa	SHOCK OVERPRESSURE psi	REFLECTED OVERPRESSURE kPa	REFLECTED OVERPRESSURE psi	PANEL DISPLACEMENT cm	PANEL DISPLACEMENT in	DISPLACEMENT TIME, 1/4 CYCLE ms	PANEL VIBRATION Hz	PANEL DAMAGE	REMARKS
24-78-82	1.27 cm	103.6	13.6	1.07	28.7	4.16	1.49	0.59	3.9	119	Small crack	All panels simply supported at ends. (Free ends).
24-78-81	A-D Interior Group I	103.6	14.7	2.13	31.2	4.52	4.30	1.69	---	---	Broken	
24-78-83		103.5	14.9	2.16	31.6	4.58	> 5.00	> 1.97	---	---	Blown out	
24-78-80		103.6	17.3	2.51	37.0	5.56	> 5.96	> 2.35	---	---	Blown out	
24-78-95	1.59 cm	102.7	33.4	4.84	75.7	11.0	1.01	0.40	2.7	218	No damage	Free span $L = 39.37$ cm
24-78-95C	BB Class I	102.7	35.8	5.19	81.8	11.9	1.12	0.44	2.5	207	No damage	
24-78-97	Exterior	103.0	37.8	5.48	86.9	12.6	1.31	0.52	2.5	207	Broken 1 ply	
24-78-96		103.0	38.0	5.31	87.4	12.7	1.43	0.56	2.7	189	Broken 1 ply	
24-78-93		103.0	40.3	5.84	93.4	13.5	> 3.01	> 1.19	---	---	Blown out	
24-78-86	1.90 cm	103.0	27.4	3.97	60.8	8.81	0.92	0.04	2.7	192	Broken 2 plies	No damage
24-78-90	A-C Exterior Group I	102.9	32.2	4.67	72.7	10.5	1.41	0.56	2.8	178	No damage	
24-78-92		103.0	33.4	4.84	75.7	11.0	> 3.01	> 1.19	---	---	Blown out	
24-78-91		103.1	34.4	4.99	78.2	11.3	> 3.01	> 1.19	---	---	Blown out	
24-78-104	2.54 cm	102.0	48.8	7.08	116.3	16.9	1.06	0.42	2.2	215	No damage	No damage
24-78-105	A-C Exterior Group I	102.4	49.9	7.24	119.3	17.3	0.96	0.38	2.2	210	Broken	
24-78-102		102.1	56.9	8.25	139.0	20.2	> 3.4	> 1.34	---	---	Blown out	
24-78-103		102.0	53.5	7.76	129.4	18.8	> 3.4	> 1.34	---	---	Blown out	

Table II. Loading Data for 2x's and PSSP Closures

SHOT NO.	TYPE PANEL	AMBIENT PRESSURE kPa	SHOCK OVERPRESSURE kPa	SHOCK OVERPRESSURE psi	REFLECTED OVERPRESSURE kPa	REFLECTED OVERPRESSURE psi	PANEL DISPLACEMENT cm	PANEL DISPLACEMENT in	DISPLACEMENT TIME, 1/2 CYCLE ms	PANEL VIBRATION Hz	PANEL DAMAGE	REMARKS
24-78-106	2x's placed flat with 0.635 cm A-D interior Group 1 plywood	102.4	47.0	6.81	111.4	16.2	0.27	0.11	1.4	417	None	All panels simply supported at ends. Plywood used upstream to seal 2x's
24-78-106A		102.4	55.9	8.11	136.1	19.7	0.34	0.13	1.4	500	None	
24-78-106B		102.4	64.4	9.34	160.7	23.3	0.39	0.15	1.2	434	None	
24-78-106C		102.4	68.1	9.88	171.6	24.9	0.41	0.16	1.7	434	None	
24-78-106D		102.4	71.1	10.3	180.7	26.2	0.46	0.18	1.3	476	None	
24-78-106E		102.4	80.0	11.6	208.3	30.2	0.50	0.20	1.2	476	None	
24-78-106F		102.4	89.3	13.0	238.0	34.5	0.56	0.22	1.2	500	None	
24-78-106G		102.4	100.0	14.5	273.4	39.6	0.67	0.26	1.3	435	None	
24-78-106H		102.4	108.5	15.7	302.6	43.9	0.69	0.27	1.2	454	None	
24-78-107B		102.3	129.6	18.8	378.4	54.9	0.82	0.32	1.1	667	None	
24-73-107C		102.3	140.7	20.4	420.0	60.9	0.85	0.33	1.1	577	Slight crack	
24-78-113		103.1	175.1	25.4	555.5	80.5	1.12	0.44	1.4	---	1-2x4 broken	
24-78-110		103.6	177.9	25.8	566.1	82.1	1.39	0.55	1.4	---	2-2x4 broken	
24-78-112		103.1	179.9	26.1	575.2	83.4	1.58	0.62	1.4	---	Blown out	
24-78-111	103.1	183.2	26.6	588.9	85.4	2.44	0.96	1.4	---	3-2x4 out		
24-78-121	PSSP-no glue	103.7	55.4	8.04	134.4	19.5	0.78	0.31	1.4	370	Nails loosened	Plywood nailed but not glued.
24-78-124		103.5	55.7	8.08	135.2	19.6	0.82	0.32	1.4	312	Nails loosened	
24-78-122		103.5	56.7	8.22	138.1	20.0	0.67	0.26	1.4	447	Outer layer cracked	
24-78-123		103.5	58.7	8.51	143.8	20.8	0.90	0.35	1.4	---	Outer layer broken	
24-78-120	103.7	60.7	8.80	149.5	21.7	0.95	0.37	1.4	---	Blown out	Blown out	
24-78-116A	PSSP-glued	103.8	61.1	8.86	150.6	21.8	0.26	0.10	1.4	---	Outer layer broken	Plywood nailed and glued.
24-78-119		103.7	63.1	9.15	156.5	22.7	0.45	0.18	1.2	---	Blown half out	
24-78-118		103.8	64.6	9.37	160.8	23.3	0.09	0.04	1.4	---	Nails loosened	
24-78-118A		103.7	65.5	9.50	163.5	23.7	---	---	---	---	Blown out	
24-78-117		103.8	69.3	10.1	174.8	25.4	3.44	1.35	1.5	---	Blown out	
24-78-115	103.8	73.5	10.7	187.5	27.2	---	---	---	---	Blown out		

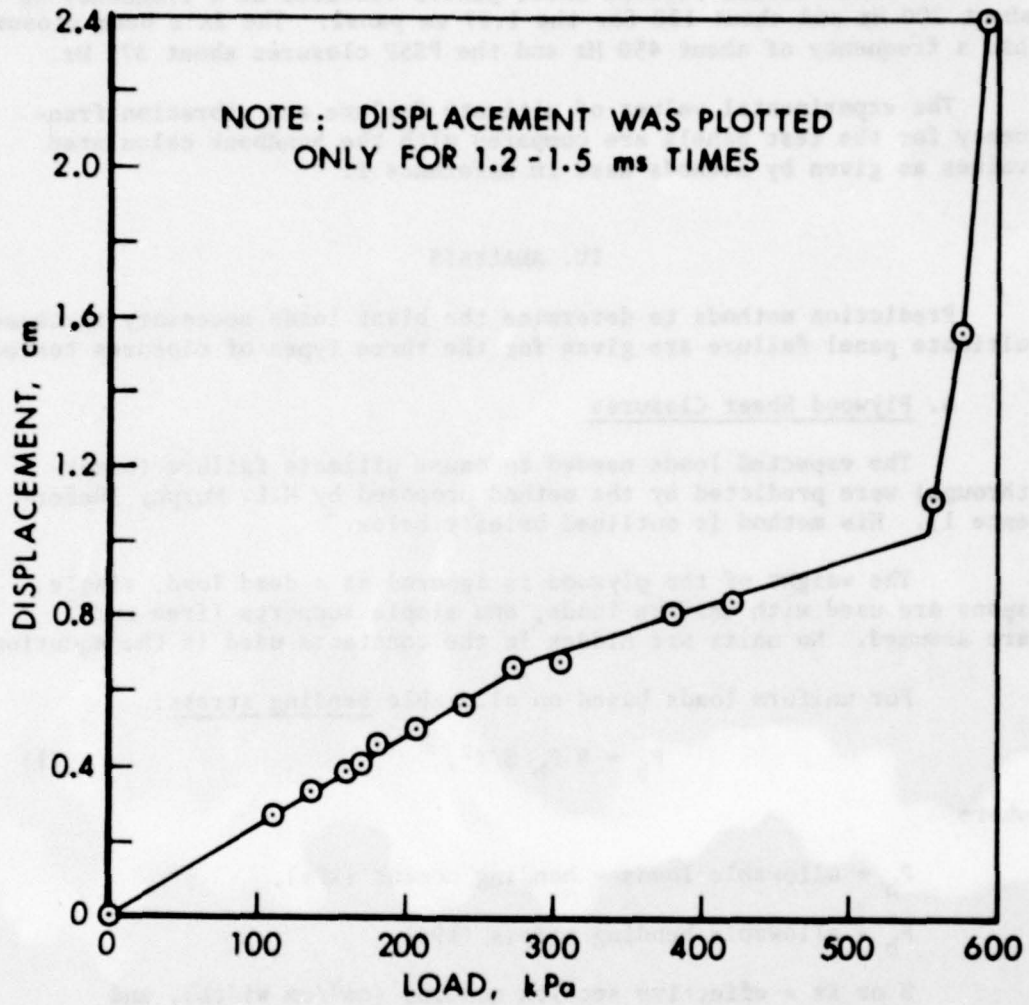

Figure 18. Displacement load, kPa as a function of load for flat 2x's

(plywood skins) at about 147 kPa (21.3 psi) for skins nailed only and 154 kPa (22.3 psi) for nailed and glued plywood skins. The glue seemed to have added some small amount of additional strength. The whole panel, including stringers, seems to blow out when the skins were only nailed. The skins broke out when they were glued and nailed.

The three larger plywood sheet panels vibrated at a frequency of about 200 Hz and about 120 for the 1.27 cm panel. The 2x's beam closure had a frequency of about 450 Hz and the PSSP closures about 375 Hz.

The experimental values of ultimate failure and vibration frequency for the test panels are compared with the handbook calculated values as given by methods used in Reference 1.

IV. ANALYSIS

Prediction methods to determine the blast loads necessary to cause ultimate panel failure are given for the three types of closures tested.

A. Plywood Sheet Closures

The expected loads needed to cause ultimate failure (break-through) were predicted by the method proposed by H.L. Murphy (Reference 1). His method is outlined briefly below.

The weight of the plywood is ignored as a dead load, single spans are used with uniform loads, and simple supports (free ends) are assumed. No units are hidden in the constants used in the equations.

For uniform loads based on allowable bending stress:

$$P_b = 8 F_b S / \ell^2, \quad (1)$$

where

P_b = allowable loads - bending moment (kPa),

F_b = allowable bending stress (kPa),

S or K_s = effective section modulus (cm^3/cm width), and

ℓ = clear span (cm).

For uniform loads based on allowable rolling shear stress:

$$P_{st} = 2 F_s (I_b/Q) / \ell, \quad (2)$$

where

- P_{st} = allowable load-rolling shear stress (kPa),
- F_s = allowable rolling shear stress (kPa),
- (Ib/Q) = rolling shear constant (cm^2/cm width), and
- ℓ = clear span (cm).

The useful allowable load P_m becomes:

$$P_m = P_b \text{ or } P_{st}, \text{ whichever is smaller (kPa).} \quad (3)$$

For the present test panels $P_m = P_b$.

A ductility factor is included to give:

$$P_{dm} = 5/6 P_m: \quad (3a)$$

For bending deflection (elastic) under uniform load:

$$Y_b = P_m \ell^4 / (76.8 I (1.1E)) \quad (4)$$

where

- Y_b = bending deflection (elastic) under uniform load (cm),
- I = effective moment of inertia (cm^4/cm width),
- E = modulus of elasticity (kPa), and
- ℓ = clear span (cm).

For shear deflection (elastic) under uniform load:

$$Y_s = P_m C t^2 \ell^2 / (106 E I), \quad (5)$$

where

- Y_s = shear deflection (elastic) under uniform load (cm),
- C = 120 or 60 for panels applied with face grain perpendicular to or parallel to supports, respectively, and
- t = nominal panel thickness (cm).

For combined bending and shear deflection (elastic) either add Y_b and Y_s from Equations 4 and 5 or use Equation 4 only with the constant 1.1 dropped from the equation.

For the plywood bearing face under uniform load (ends over simple supports):

$$l_e = l / (2((F_{cl} / P_m) - 1)), \quad (6)$$

where

l_e = required plywood end bearing length at each end of panel (cm), and

F_{cl} = allowable bearing stress on the plywood face, for load perpendicular to plane of outer ply actually in bearing (kPa).

Reference 1 recommended that l_e be at least 3.8 cm; this recommendation was followed for the plywood panels just tested.

Ultimate failure for the panels was calculated by using values furnished in Reference 4, of materials strength parameters (Table 3), to give the allowable loads. These values were then corrected for the ductility ratio and multiplied by a factor of four as suggested by Murphy (Reference 1) to give the expected blast load needed to cause ultimate failure of the closures. Table 4 lists the predicted values.

B. Wood Beam Closures

Again the predictions of ultimate loads to fail the wood beam closures follow the methods of Murphy (Reference 1). The assumptions are the same as for the plywood closures.

The flexural or bending resistance is calculated from Equation 7:

$$q_b = 0.5 F_b (d/l)^2 / (3c), \quad (7)$$

where

F_b = extreme fiber stress in bending (kPa),

l = clear span (cm),

d = thickness (depth) of beam (cm), and

c = 1/8 for simply supported beams.

⁴"Plywood Design Specification," American Plywood Association, P.O. Box 2277, Tacoma, Wash. 98401, December 1976.

Table III. Properties for the Wood Test Closures

PANEL TYPE	GRADE STRESS LEVEL	F _b kPa	F _c kPa	F _{cl} kPa	F _s kPa	F _t kPa	F _v kPa	F kPa	G kPa
Plywood sheets 0.64 cm A-D Interior Group I	S-3 Dry	11,376	10,618	2,344	330.9	11,376	1,447	12.4x10 ⁶	565,370
1.27 cm A-D Interior Group I	S-3 Dry	11,376	10,618	2,344	330.9	11,376	1,447	12.4x10 ⁶	565,370
1.59 cm B-B Class I Exterior	S-2 Dry	11,376	10,618	2,344	365.4	11,376	1,724	12.4x10 ⁶	620,528
1.90 cm A-C Exterior Group I	S-1 Dry	13,789	11,307	2,344	365.4	13,789	1,724	12.4x10 ⁶	620,528
2.54 cm A-C Exterior Group I	S-1 Dry	13,789	11,307	2,344	365.4	13,789	1,724	12.4x10 ⁶	620,528
Wood Beams 2x's (3.81 cm thick) HEM-FIR	S-Dry	11,376	8,963	1689	—	6,722	517	10.34x10 ⁶	636,540

Table III. (Cont)

PANEL TYPE	Approximate Weight gm/cm ³	Effective Thickness Shear cm	PARALLEL					PERPENDICULAR				
			I cm ⁴ /cm	S=KS cm ³ /cm	Ib/Q cm ² /cm	A cm ² /cm	I cm ⁴ /cm	S=KS cm ³ /cm	Ib/Q cm ² /cm	A cm ² /cm		
Plywood Sheets 0.64 cm A-D Interior Group I	0.616	0.706	0.012	0.036	0.462	0.277	0.0014	0.010	—	0.144		
1.27 cm A-C Interior Group I	0.577	1.143	0.105	0.143	1.023	0.412	0.024	0.080	0.655	0.271		
1.59 cm J-3 class I Exterior	0.554	1.198	0.176	0.190	1.331	0.483	0.061	0.125	0.830	0.344		
1.91 cm A-C Exterior Group I	0.564	1.496	0.269	0.243	1.688	0.610	0.126	0.208	1.033	0.445		
2.54 cm A-C Exterior Group I	0.577	2.148	0.577	0.392	1.880	0.799	0.345	0.399	1.617	0.749		
Wood Beams 2x's (3.71 cm thick) HEM-FIR	0.481	—	—	—	—	—	—	—	—	—		
OSB	0.535	—	—	—	—	—	—	—	—	—		

Table IV Predicted Values for Ultimate Failure

PANEL TYPE	Allowable Load P_b , kPa	Bending Deflection y_b , cm	Deflection Predicted H_2	Deflection Frequency H_2 Experiment	Ultimate Failure Predicted kPa	Ultimate Failure Experiment	Ratio $\frac{\text{Ultimate Failure}}{\text{Allowable Load}}$
Plywood sheets 1.27 cm A-D Interior Group I	8.40	0.20	176	119	28.0	31.4	3.7
1.59 cm 8-B Class I Exterior	11.16	0.16	222	213	37.2	90.4	8.1
1.90 cm A-C Exterior Group I	17.29	0.16	260	178	57.6	74.2	4.3
2.54 cm A-C Exterior Group I	27.90	0.12	344	215	93.0	124.3	4.5
Beam Closures 2x's placed flat, w/0.64 cm loose plywood skin	82.7	0.11	517	448	276	488	5.9
PSSP 2-0.64 cm skins, w/3.81 cm stringers	7.28	0.04 Nailed and glued 631 Nailed only	631	376	21.8	147	20.2
						154	

Note: all closures tested had a free span, l , of 39.37 cm.

The horizontal shear resistance is found from Equation 8:

$$q_v = 2F_v d / (3c'(\ell - 2d)), \quad (8)$$

where

F_v = horizontal shear stress (kPa),

ℓ = clear span (cm),

d = thickness (depth) of beam (cm), and

c' = 1/2 for simply supported beams.

The wood beam resistance, q , is then equal to lesser value of q_b and q_v .

$$q = \text{least of } q_b \text{ and } q_v. \quad (9)$$

The air blast load to cause ultimate failure is found from Equation 10:

$$P_m = 4(1 - 1/(2\mu))q, \quad (10)$$

where the design ductility ratio $\mu = 3$, and

$$P_m = 4(5/6)q. \quad (11)$$

The required bearing length at each end is:

$$\ell_e = q\ell c' / F_{cl} \quad (12)$$

where

ℓ = clear span (cm),

F_{cl} = compression stress perpendicular to grain or bearing stress (kPa), and

c' = 1/2.

ℓ_e is recommended to be at least 3.81 cm.

The calculated load to cause ultimate failure for the wood beam closure (2x's placed flat), after multiplying the least allowable load, q_v , by the ductibility ratio and by a factor of 4, is given in Table IV.

B. Plywood Stressed-Skin Panel Closures

The analysis of the plywood stressed-skin panel closures (PSSP) again follows closely that given in Reference 1. The panels are assumed to be uniformly loaded with the outer plies of the two plywood skins to be parallel to the stringers.

A view of the end section of the PSSP closure to be tested is shown in Figure 19. The clear distance between stringers should be less than twice the basic spacing, b , as given in Table 5, for these calculations to apply. See Figure 19A.

The neutral axis (N.A.) is calculated by following the steps of Figure 19A. A value of EI_g , the stiffness factor, is calculated for the combined skins and stringers of the test panel, Figure 19B.

The allowable load in panel deflection is:

$$P_d = 1 / (C \ell \ell' \left(\frac{5}{384} \frac{\ell^2}{EI_g} + \frac{0.15}{AG} \right)) + DL \quad (13)$$

where

P_d = allowable total load-panel deflection (kPa),

C = factor for maximum allowable deflection - 360 for floors,
240 for roofs,

EI_g from Figure 19 (kPa - cm^4),

A = actual total cross section area of all stringers (cm^2),

G = modulus of rigidity of stringers (kPa) taken as 0.06 (1.03E),

ℓ = clear span of panel in direction of stringers (cm), and

ℓ' = width of panel - for skins in direction perpendicular to ℓ (cm).

The dead weight (DL) is zero for the present test panel since each panel was loaded as a wall panel, (upright position), not as a floor panel.

$P_d = 117.6$ kPa (17.1 psi) for the PSSP tested - the allowable total load for panel deflection.

The allowable total load - top skin deflection (cross panel), is:

$$P_t = 384 EI / (c(\ell'')^3) + DL, \quad (14)$$

NOTE: DIMENSIONS IN CENTIMETRES.

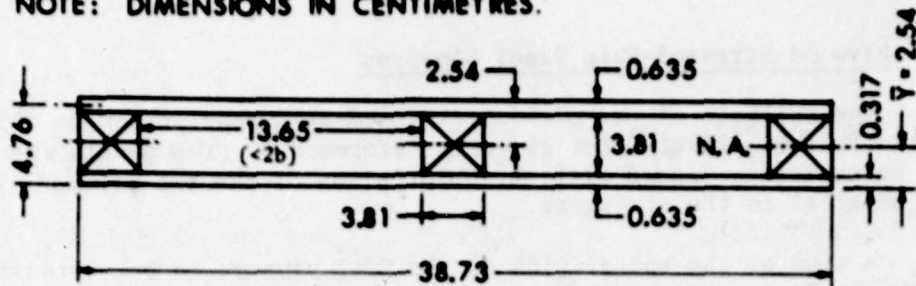

Values of A_{11} and E are from Table III.

ITEM	$E, \text{ kPa}$	$A_{11}, \text{ cm}^2$	$A_{11}E, \text{ cm}^2\text{-kPa}$	$Y, \text{ cm}$	$A_{11}EY, \text{ cm}^3\text{-kPa}$
Top Skin	$12.4 \times 10^6 \times 1.1$	38.73×0.277	146.3×10^6	4.76	696.5×10^6
Stringers	$10.34 \times 10^6 \times 1.03$	3×14.52	463.9×10^6	2.54	$1,178 \times 10^6$
Bottom Skin	$12.4 \times 10^6 \times 1.1$	38.73×0.277	146.3×10^6	0.317	46.4×10^6
			756×10^6		$1,921 \times 10^6$

$$\bar{Y} = \frac{\sum A_{11} E Y}{\sum A_{11} E} = \frac{1,921 \times 10^6}{756 \times 10^6}$$

$$\bar{Y} = 2.54$$

A. Neutral axis

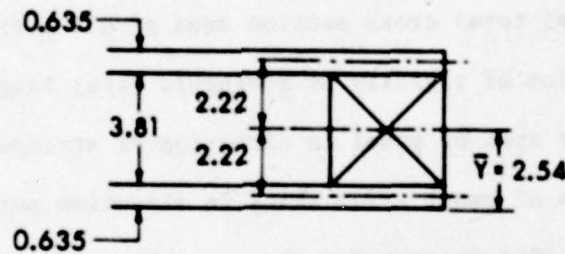

Values of I are from Table III.

ITEM	$E, \text{ kPa}$	$I, \text{ cm}^4$	$A_{11}, \text{ cm}^2$	$d, \text{ cm}$	$d^2, \text{ cm}^2$	$A_{11}d^2, \text{ cm}^4$	$I + A_{11}d^2, \text{ cm}^4$	$E(I + A_{11}d^2), \text{ kPa} \cdot \text{cm}^4$
Top Skin	13.6×10^6	0.0542	10.73	2.22	4.93	52.90	52.95	720.1×10^6
Stringers	10.65×10^6	52.68	43.56	0.0	0.0	0.0	52.68	561.0×10^6
Bottom Skin	13.6×10^6	0.0542	10.73	2.22	4.93	52.90	52.95	720.1×10^6

$$I_g = 159.0 \times 2,001.2 \times 10^6$$

$$EI_g = 2,001 \times 10^6 \text{ kPa} \cdot \text{cm}^4 / \text{panel width}$$

B. Value of EI_g

Figure 19. Neutral axis for deflection and EI_g for PSSP closure.

Table V Basic Spacing, b, for Various Plywood Thicknesses
(Face grain parallel to stringers*)

Plywood Thickness, cm	3	Basic Spacing, b, cm Number of plies			
		4 (3 layer)	5 (5 layer)	6 (6 layer)	7 (7 layer)
0.635 Sanded	25.4				
0.794 Unsanded	30.5				
0.952 Unsanded	40.6				
0.952 Sanded	48.3				
1.27 Unsanded, sanded, touch-sanded	55.9	55.9	55.9		
1.59 Unsanded, sanded	68.6	88.9	83.8		
1.59, 1.51 Touch-sanded		68.6	81.3		
1.90 Unsanded, sanded, touch-sanded		91.4	96.5	96.5	
1.83 Touch-sanded		88.9	86.4	94.0	
2.22 Unsanded			122		99.0
2.22 Sanded					130
2.54 Unsanded, sanded					135
2.86 (2-4-1)					142

* Where plywood face grain is across stringers, write APA for appropriate "B" distances.

where

P_t = allowable total load - top skin deflection (kPa),

C = factor for maximum allowable deflection - 360 for floors and 240 roofs,

E is for top skin (kPa),

I = stress applied perpendicular to stringer and face grain (cm^4/cm),

l'' = clear distance between stringers (cm), and

l''/C = midspan deflection (cm).

when DL is zero $P_t = 7.28$ kPa (1.06 psi) for the top skin of the panel tested.

The total allowable load in bending is found from Equation 15:

$$P_b = (8F/c l' l^2) (EI_n / E_{\text{skin}}), \quad (15)$$

where

P_b = allowable load in bending (kPa) where EI_n is for bending about a neutral axis, calculated as in Figure 19 but with the effective width of bottom skin to be used. For the present test, panel spacing $l' < b/2 +$ stringer width (the effective width), and therefore

$EI_n = EI_g$ as already calculated (kPa - cm^4).

$F = F_c$ or F_t (F_c for top skin and F_t for bottom skin) (kPa). The values of F_c and F_t are to be corrected in the following way:

if $\frac{l''}{b} = < 0.5$ use 100% of F_c and F_t ,

if ratio ≥ 1.0 to 2 use 67%, and for ratios between 0.5 and 1 vary percentage linearly between 100 and 67%.

E = skin under check including percentage increase (kPa),

c = distance to center of skin thickness from N.A (cm), and

l and l' are as before (cm).

The values of P_b are 80.0 kPa (11.6 psi) using upper skin and 85.7 kPa (12.4 psi) using bottom skin of the test panel.

The allowable total load - rolling shear is:

$$P_{st} = (2(\sum F_s t) / (\ell \ell' Q_s)) (EI_g / E_{skin}) \quad (16)$$

where the statical moment

$$Q_s = A d_s \text{ and} \quad (17)$$

$$d_c = c - y', \quad (18)$$

See Figure 20 for definition and value of y' (Table 6). $\sum F_s t$ (kPa-cm) is the sum of the glueline widths over each stringer (three in test panel) multiplied by its applicable allowable rolling shear stress F_s (Table 3 above). ℓ and ℓ' (cm) are same as before. $P_{st} = 43.2$ kPa (6.3 psi) for the test panel.

The allowable total load - horizontal shear is:

$$P_v = (2(\sum F_v t) / \ell \ell' Q_v) (EI_g / E_{st}), \quad (19)$$

where

P_v = allowable load - horizontal shear (kPa),

F_v = allowable stress in stringer horizontal shear (kPa),

t = sum of stringer width (cm),

EI_g is from Figure 12 above (kPa - cm⁴),

E_{st} is for stringer including percentage (3%) increase (kPa),

ℓ and ℓ' as before (cm), and

$$Q_v = Q_{\text{stringer}} + Q_{\text{skin}} (E_{\text{skin}} / E_{\text{stringer}}). \quad (20)$$

The terms of Q_v are:

$Q_{\text{stringers}}$ = cross section of all stringers either above or below N. A. times its centroidal distance from N.A. (cm³),

$Q_{\text{skin}} = A_{11}$ for chosen skin times moment arm (cm³), and

E 's are as before (with percentage increases) (kPa).

The value calculated for P_v is 28.4 kPa (4.13 psi) for the panel tested.

Table VI. A and y' for Computing Q_s

Plywood Thickness cm	STRUCTURAL I Grades, of any Group 4 Panel				All Other Panels			
	Face Grain I to Stringers		Face Grain I to Stringers		Face Grain I to Stringers		Face Grain I to Stringers	
	Area cm ² /cm	y' cm	Area cm ² /cm	y' cm	Area cm ² /cm	y' cm	Area cm ² /cm	y' cm
Unsanded Panels								
0.316	0.251	0.125	0.251	0.378	0.203	0.121	0.140	0.378
0.352	0.235	0.171	0.304	0.457	0.197	0.118	0.169	0.457
1.27	0.307	0.153	0.410	0.614	0.331	0.333	0.228	0.615
1.59	0.489	0.447	0.516	0.774	0.380	0.356	0.287	0.775
1.90	0.388	0.194	0.624	0.932	0.432	0.528	0.346	0.932
Sanded Panels								
0.635	0.178	0.089	0.260	0.307	0.178	0.089	0.144	0.307
0.952	0.178	0.089	0.450	0.467	0.178	0.089	0.250	0.467
1.27	0.206	0.103	0.488	0.624	0.206	0.103	0.271	0.625
1.59	0.241	0.121	0.619	0.784	0.241	0.121	0.344	0.785
1.90	0.635	0.703	0.799	0.942	0.433	0.592	0.445	0.942
Touch Sanded Panels								
1.27	0.241	0.121	0.441	0.568	0.241	0.121	0.246	0.569
2.30	0.420	0.441	0.614	0.701	0.312	0.353	0.341	0.701
1.59	0.434	0.469	0.651	0.731	0.321	0.376	0.363	0.732
1.02	0.321	0.160	0.767	0.873	0.431	0.541	0.427	0.874
1.90	0.321	0.160	0.810	0.904	0.443	0.572	0.450	0.904
2.06					0.672	0.912	0.731	1.39

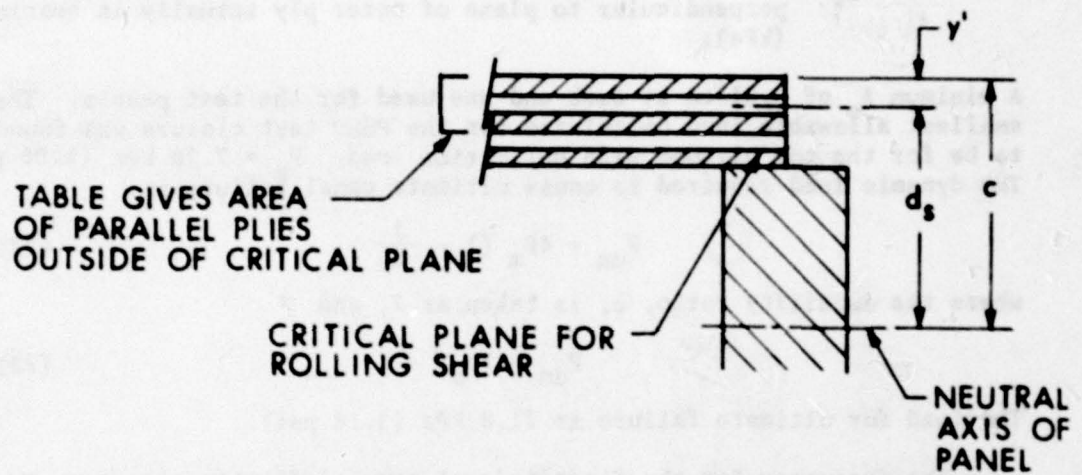

Figure 20. Rolling shear critical plane and Q_s .

The minimum bearing length at each end is:

$$l_e = P_m l / (2 F_{cl}), \quad (21)$$

where

l_e = required plywood end bearing length at each end of the panel (cm),

l = clear span (cm),

l' = full panel width (skins) (cm),

P_m = smallest of calculated allowable loads (kPa), and

F_{cl} = allowable bearing stress on plywood face, for load perpendicular to plane of outer ply actually in bearing (kPa).

A minimum l_e of 3.81 cm at each end was used for the test panels. The smallest allowable load calculated for the PSSP test closure was found to be for the top plywood skin deflection load, $P_m = 7.28$ kPa (1.06 psi). The dynamic load required to cause ultimate panel failure is:

$$P_{dm} = 4P_m \left(1 - \frac{1}{2\mu}\right) \quad (22)$$

where the ductility ratio, μ , is taken as 2, and

$$P_{dm} = 3P_m. \quad (23)$$

The load for ultimate failure is 21.8 kPa (3.16 psi).

The frequency for the first mode of panel deflection is given by Equation 24 (Reference 5). The panel is assumed to act like a simply supported beam (free at each end) which is uniformly loaded.

$$f = \frac{50\pi}{l^2} \sqrt{\frac{EI}{EAW}} \quad (24)$$

where

f = frequency of first mode (Hz),

l = free span of panel (cm),

⁵Lionel S. Marks, Editor, "Marks' Mechanical Engineers' Handbook", MacGraw-Hill Book Co., Inc., New York, NY, 1951.

EI = flexural rigidity of panel (kPa-cm⁴/panel width)

A = cross section area of panel or component (cm),

W = weight of panel or component (gm/cm³).

I is calculated from Equation 25 for all closures except PSSP closure:

$$I = \frac{w d^3}{12}, \quad (25)$$

where

w = width of panel (cm) and

d = thickness of panel (cm).

EI = EI_g from Figure 19 was used in calculations for PSSP closure.

The calculated and experimental values for P_{dm} and f for each type of closure tested are listed in Table IV. for comparison.

V. SUMMARY AND CONCLUSIONS

As a part of a program to upgrade existing shelters, the Defense Civil Preparedness Agency has had a design manual (Reference 1) prepared which describes and lists pre-designed closures. Three types are listed: plywood sheet closures, wood beam closures, and plywood stressed skin panels to be used as closures. The closures are designed to be placed in basement shelter openings - windows and entryways, for example. The intent was to use these pre-designed closures to upgrade home and commercial basements to resist increased levels of blast pressure over the shelters' present ability to protect the shelterees.

The design procedures followed in Reference 1 was to calculate the allowable static load (minimum value used if more than one) and to correct this value to a dynamic load for ultimate failure for each closure. The present work was done to verify experimentally the values of ultimate failure predicted for the closures.

The three types of closures were exposed to the loading of reflected shock overpressures at the end of the BRL 57 cm shock tube. Plywood sheet panels of various thickness (1.27, 1.59, 1.90, and 2.5 cm) were loaded to bursting while simply supported at two ends. Wood beam panels (2x's placed flat) and plywood stressed skin panels were tested in the same way. Input shock pressure and center-point panel deflection data were obtained for the different test panels.

Loading data - pressure load, panel deflection, and panel vibration frequency were listed and compared to the calculated values. Bursting loads were found to be about four times the predicted allowable load for the plywood sheet closures. The factor was about six times for the beam closures and over twenty times for the plywood stressed skin panels. The plywood skin was the weaker element in the PSSP panels as predicted but the skin was still many times stronger than it was calculated to be.

Accordingly, all the pre-designed closures as listed in Reference 1 appear to be stronger (loaded to ultimate failure) by a factor of 2-7 times than was predicted for ultimate failure.

Again, as seen in earlier experiments with closures simply supported on four sides (Reference 2), damage was light until the bursting point was reached. The panel would nearly always blow out completely when the plywood sheet closures failed. The beam closures lost one or more beams and the PSSP closures lost a great part of their skins during failure. At loads higher than burst pressure the entire panel burst into many fragments.

In general all panels tested took loads that exceeded the predicted load for ultimate failure as pre-designed.

ACKNOWLEDGMENTS

The author wishes to thank Messrs. Kenneth Holbrook and Vincent King for the careful experimental work performed at the BRL Shock Tube Facility.

APPENDIX

PRESSURE-TIME AND DISPLACEMENT-TIME
TRACES

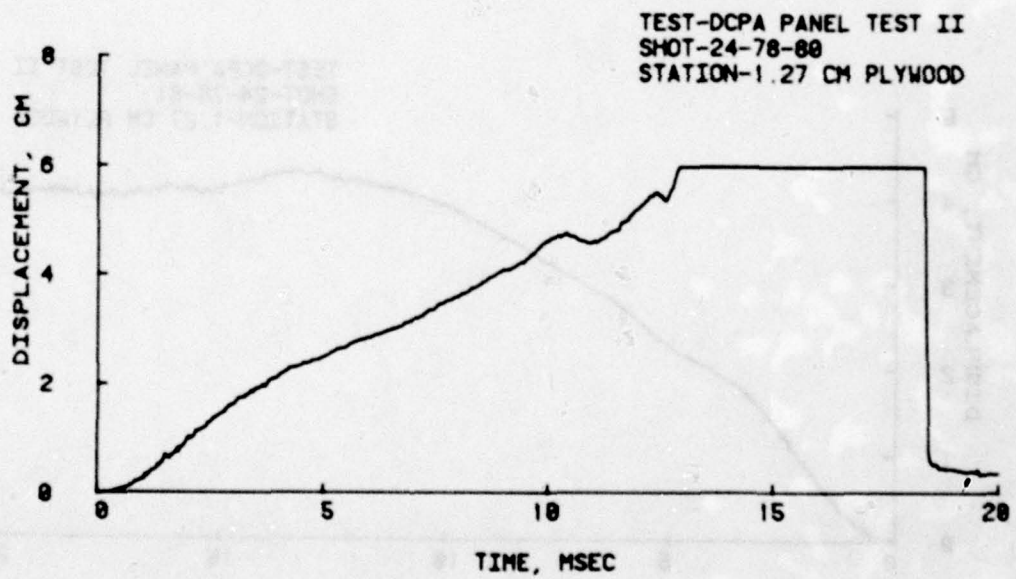
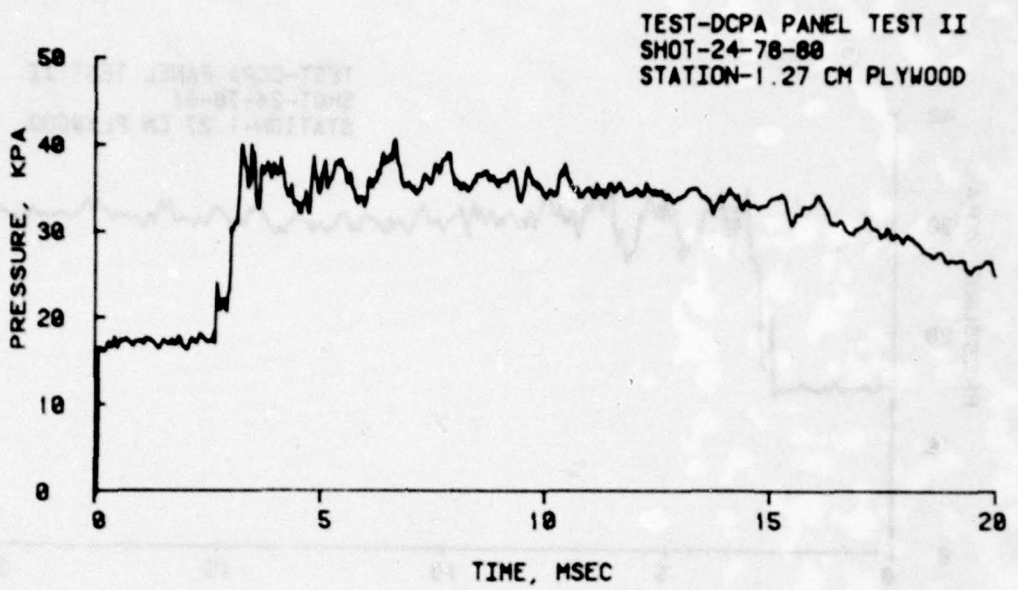

Figure A-1. Records for 1.27 cm plywood sheet closures.

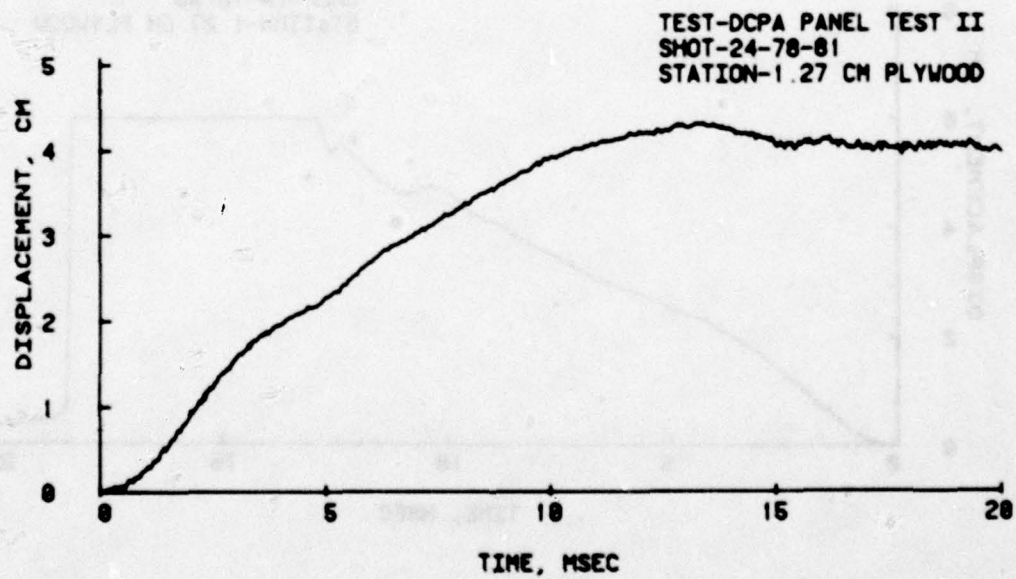
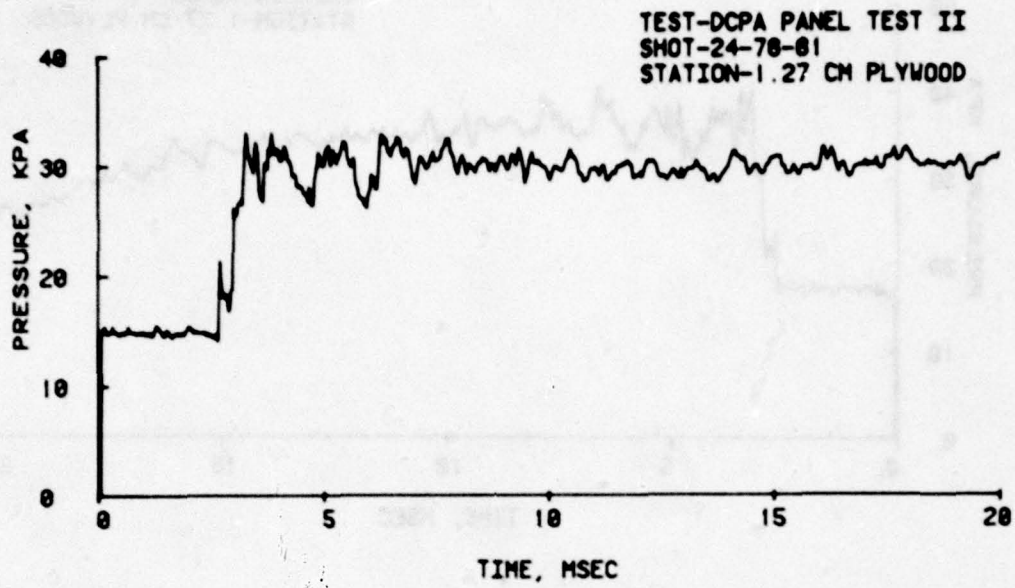

Figure A-1 (Cont). Records for 1.27 cm plywood sheet closures.

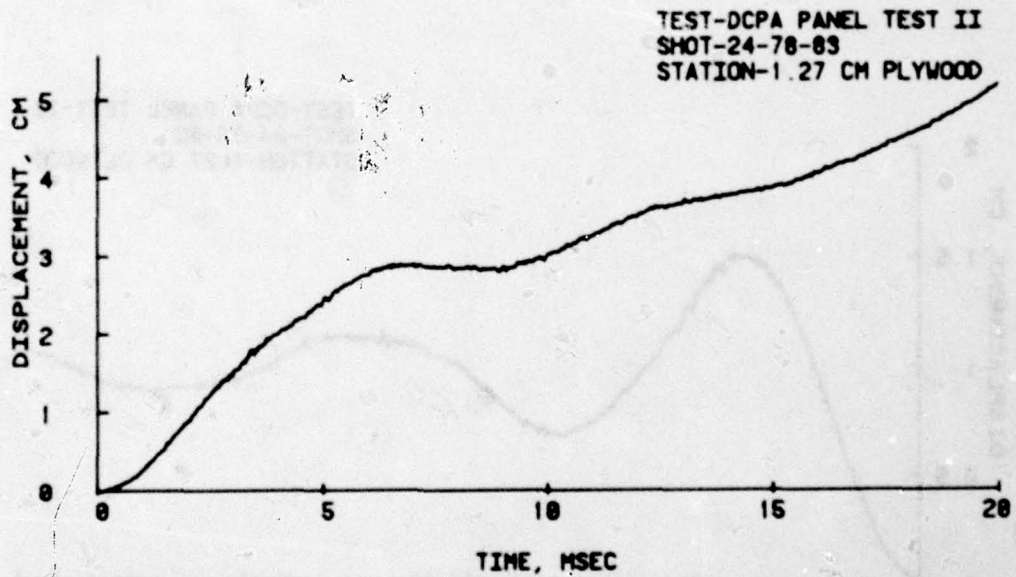
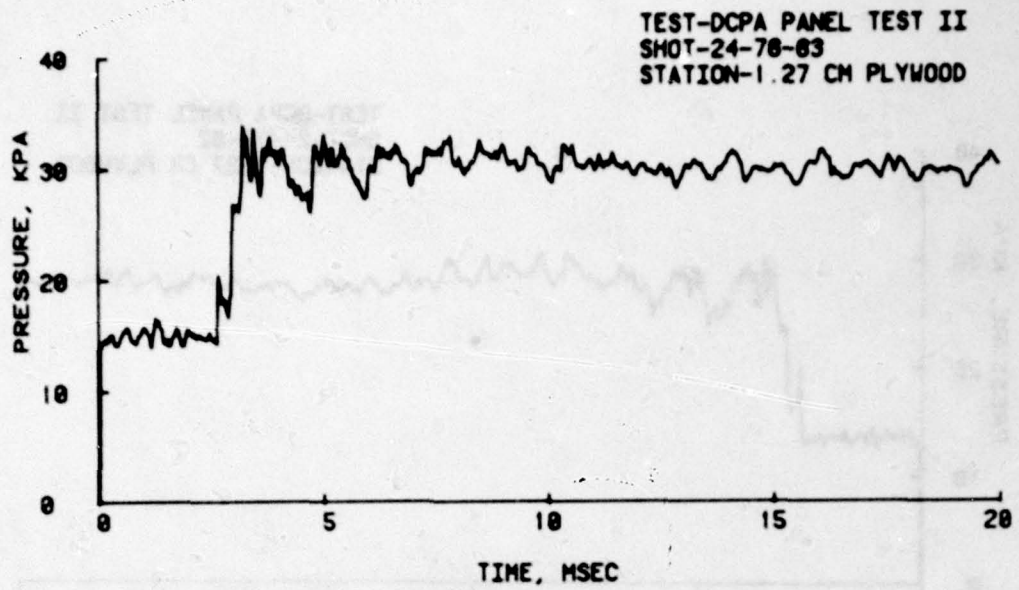

Figure A-1 (Cont). Records for 1.27 cm plywood sheet closures.

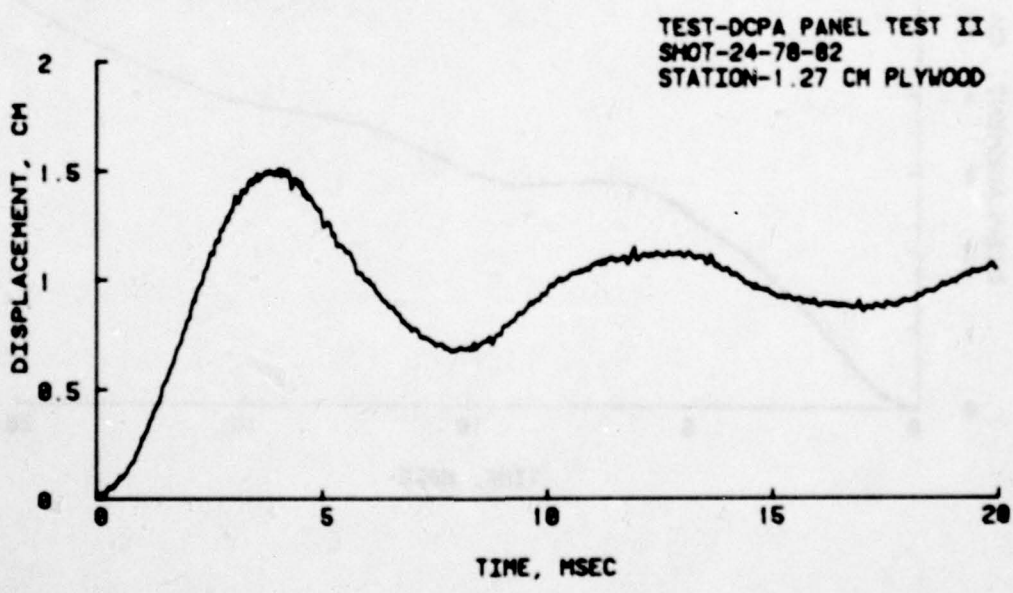
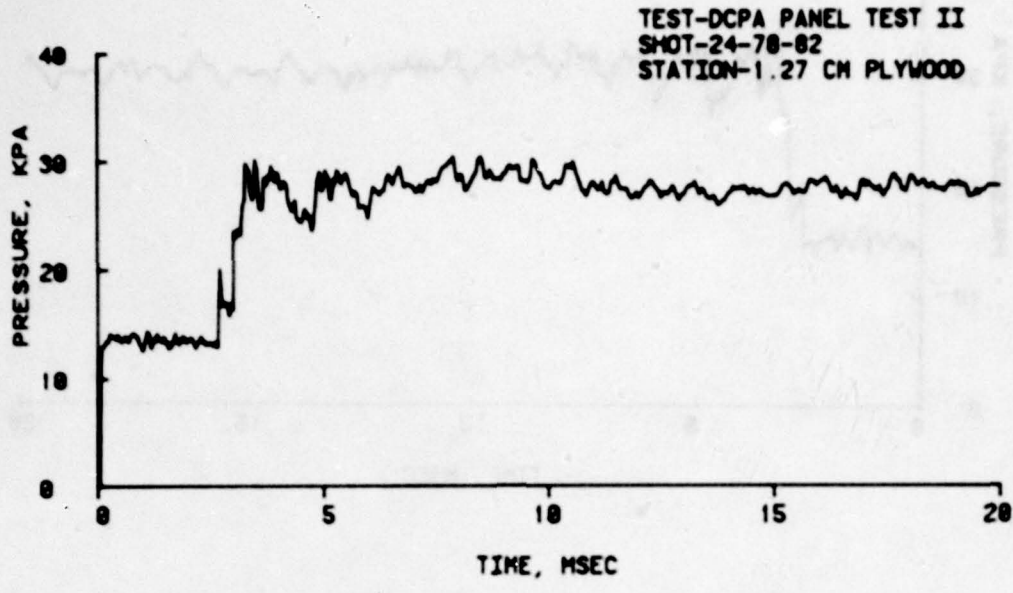

Figure A-1 (Cont). Records for 1.27 cm plywood sheet closures.

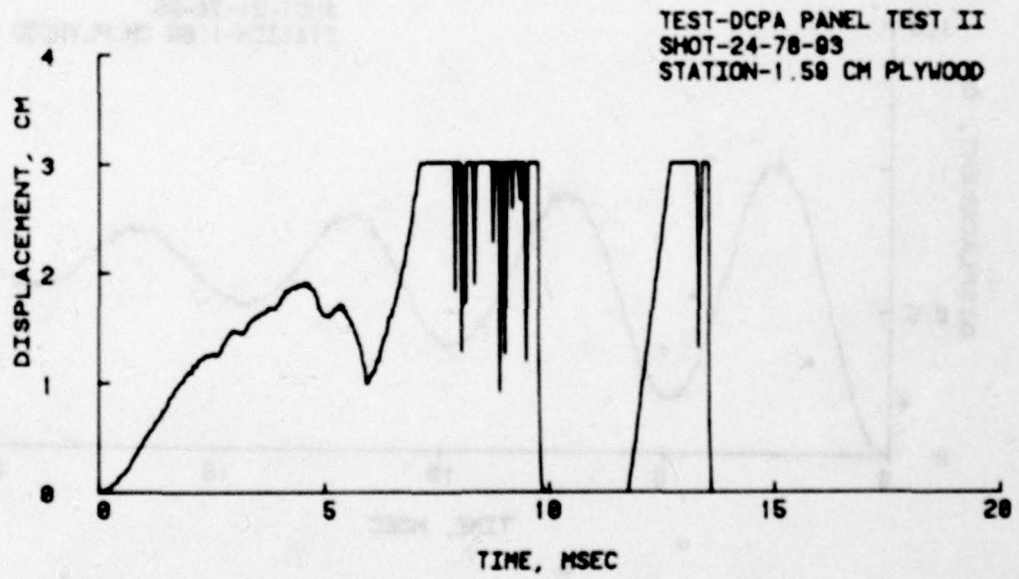
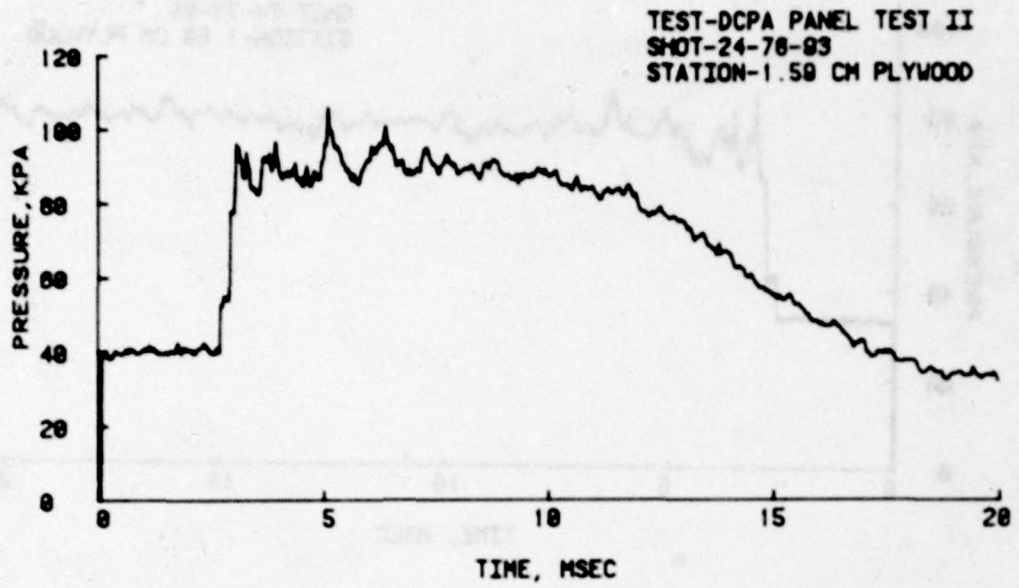

Figure A-2. Records for 1.59 cm plywood sheet closures.

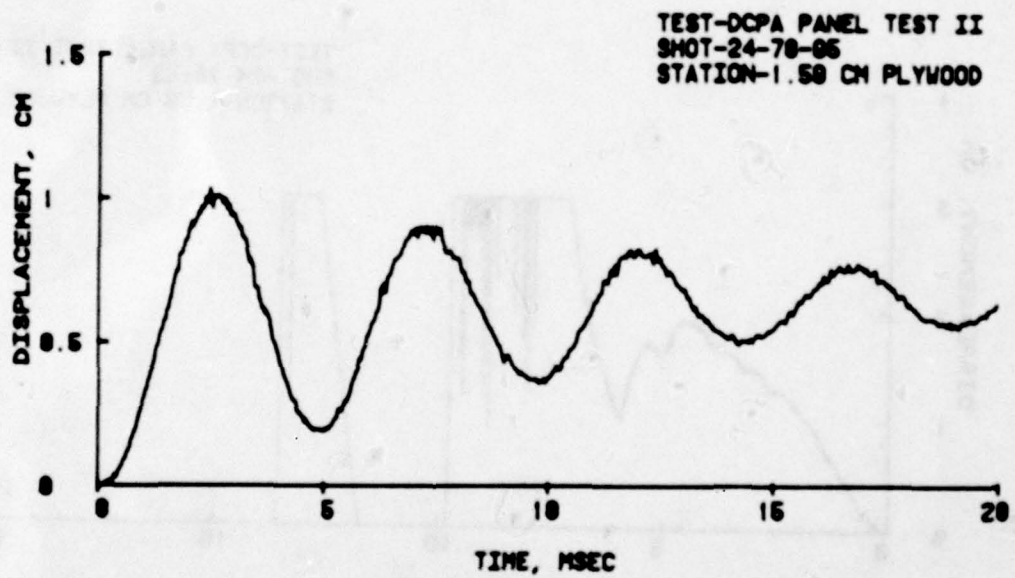
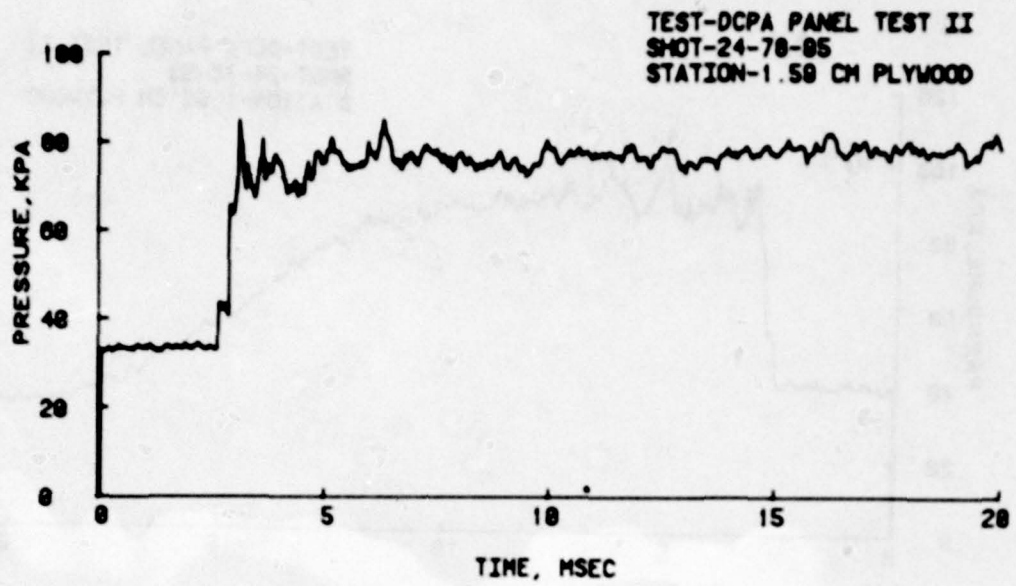

Figure A-2 (Cont). Records for 1.59 cm plywood sheet closures.

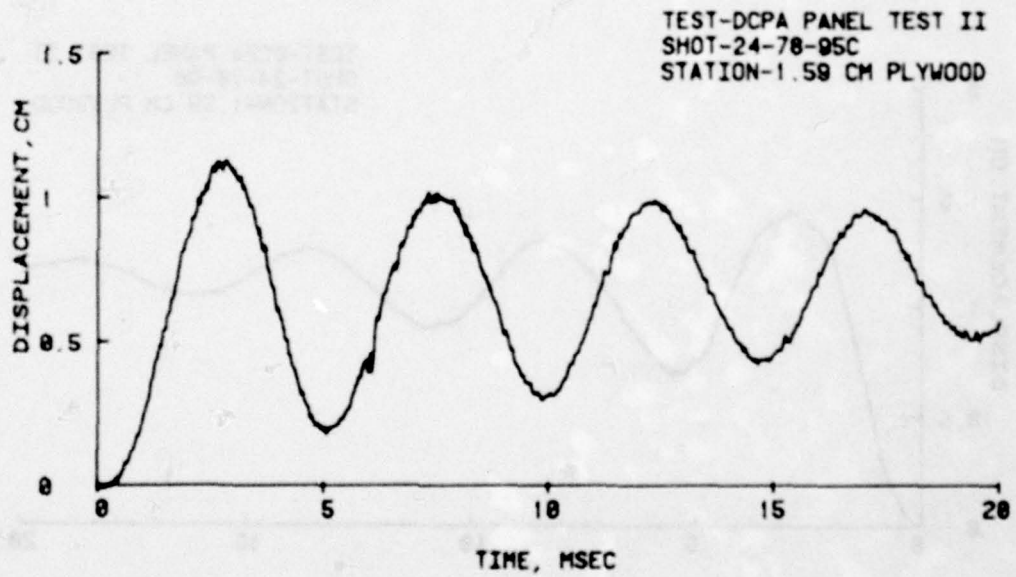
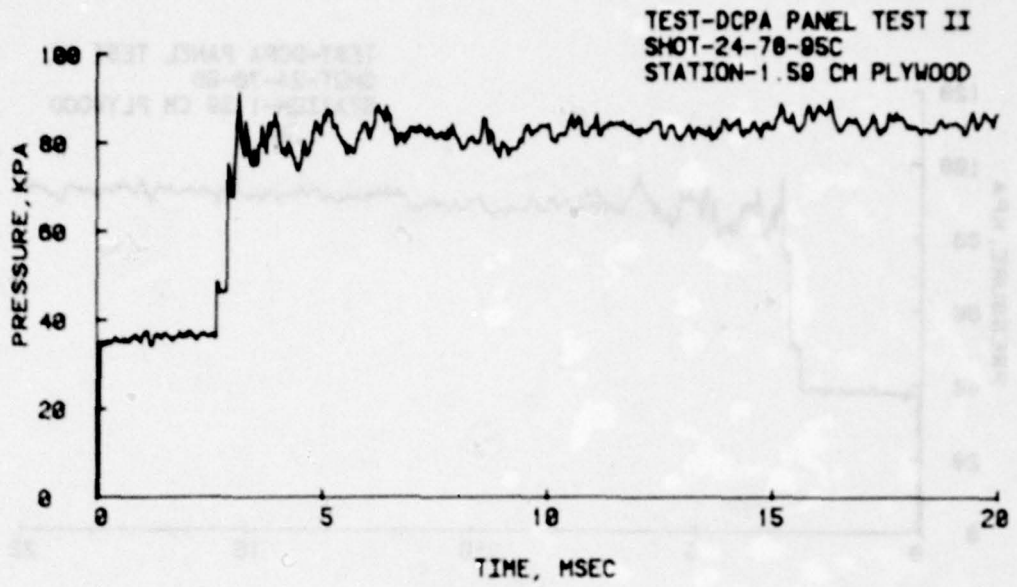

Figure A-2 (Cont). Records for 1.59 cm plywood sheet closures.

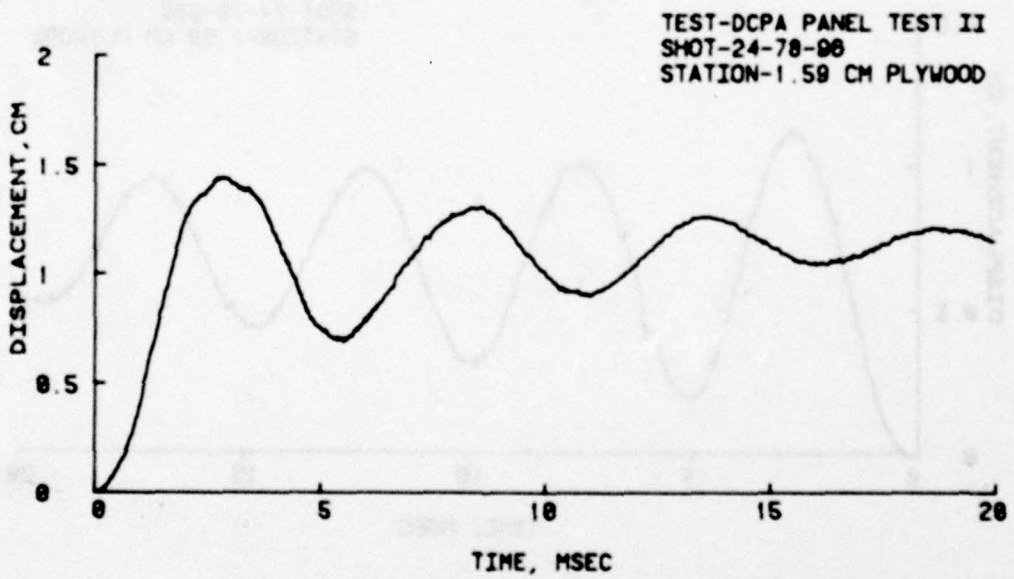
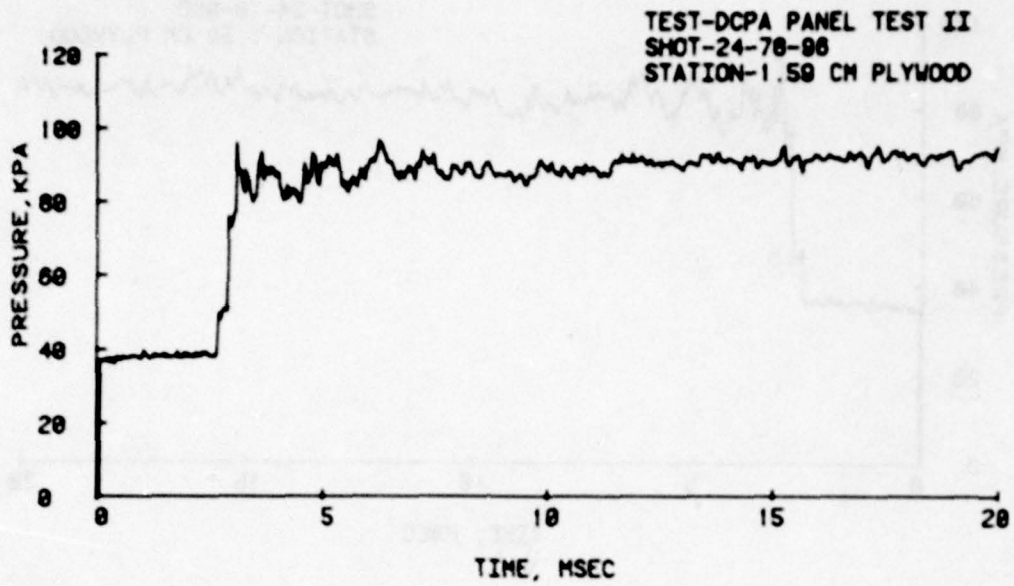

Figure A-2 (Cont). Records for 1.59 cm plywood sheet closures.

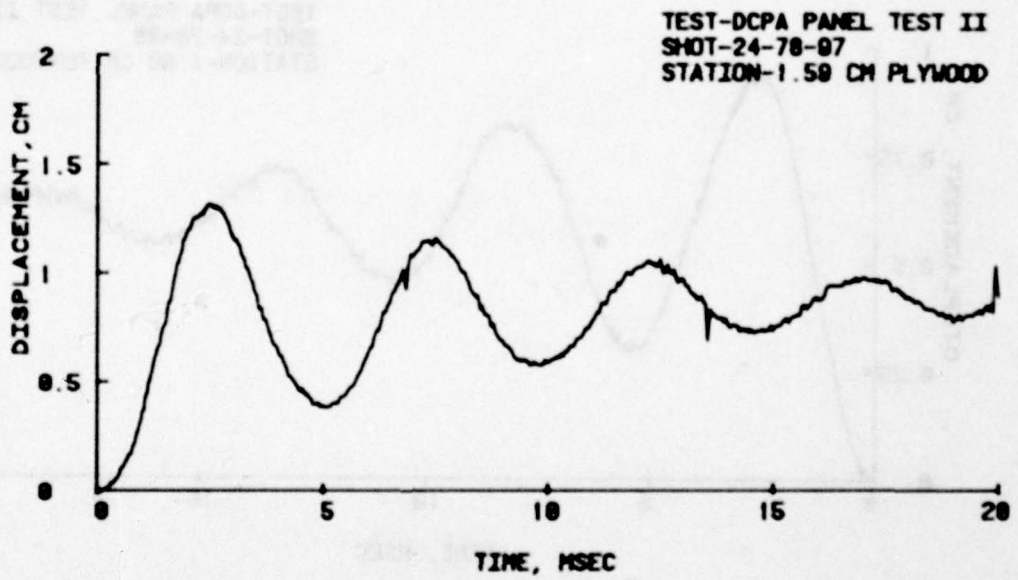
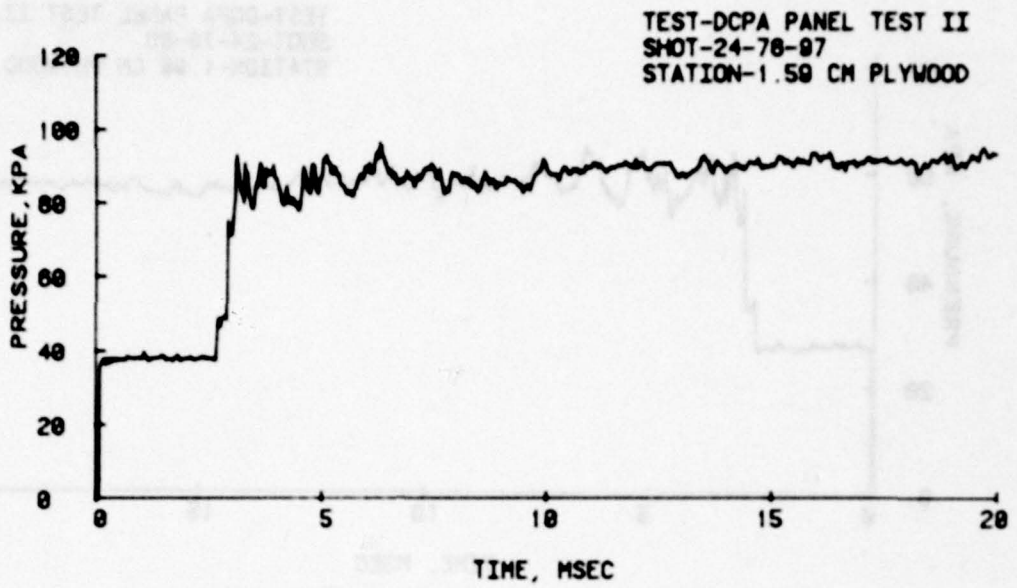

Figure A-2 (Cont). Records for 1.59 cm plywood sheet closures.

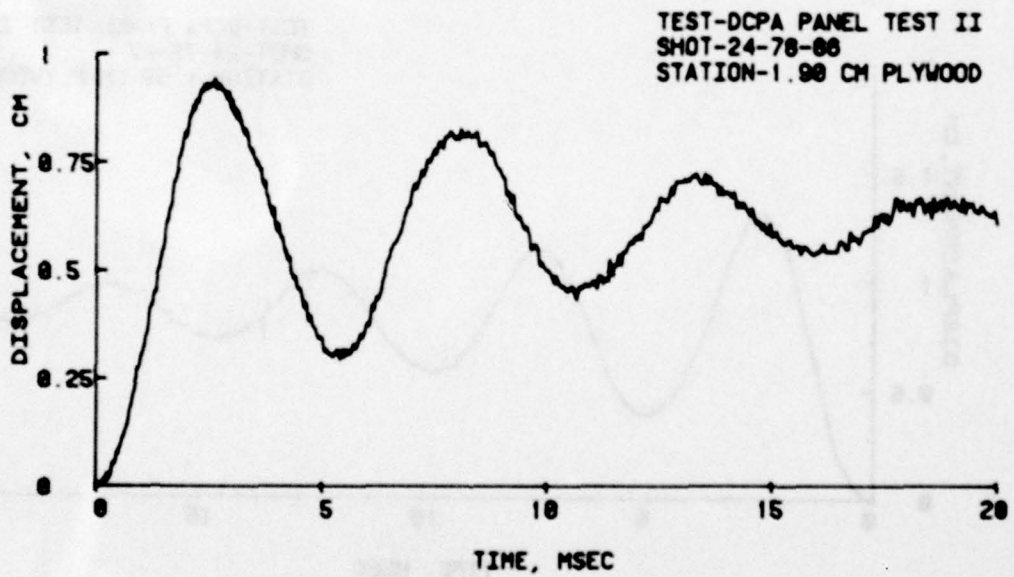
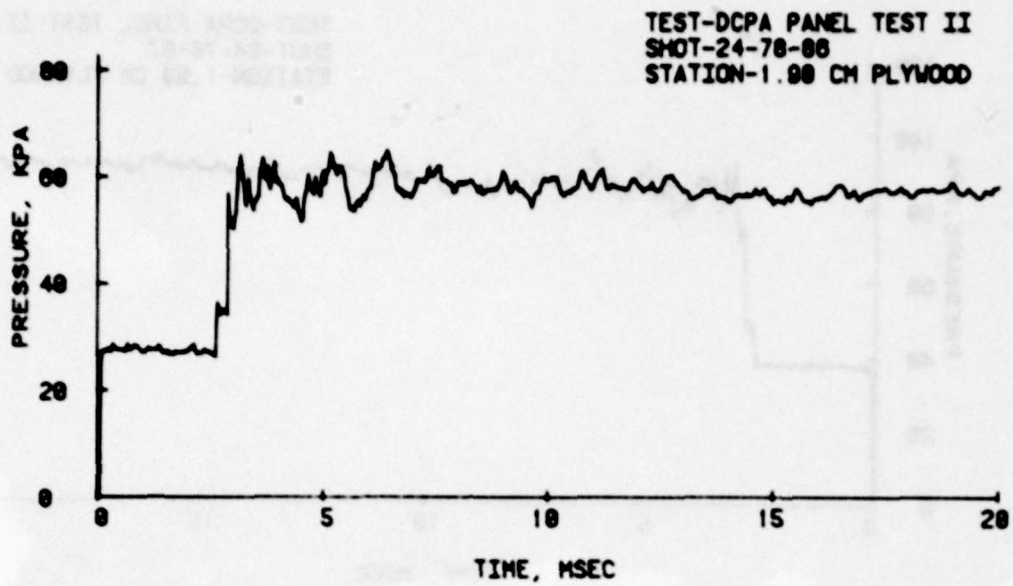

Figure A-3. Records for 1.90 cm plywood sheet closures.

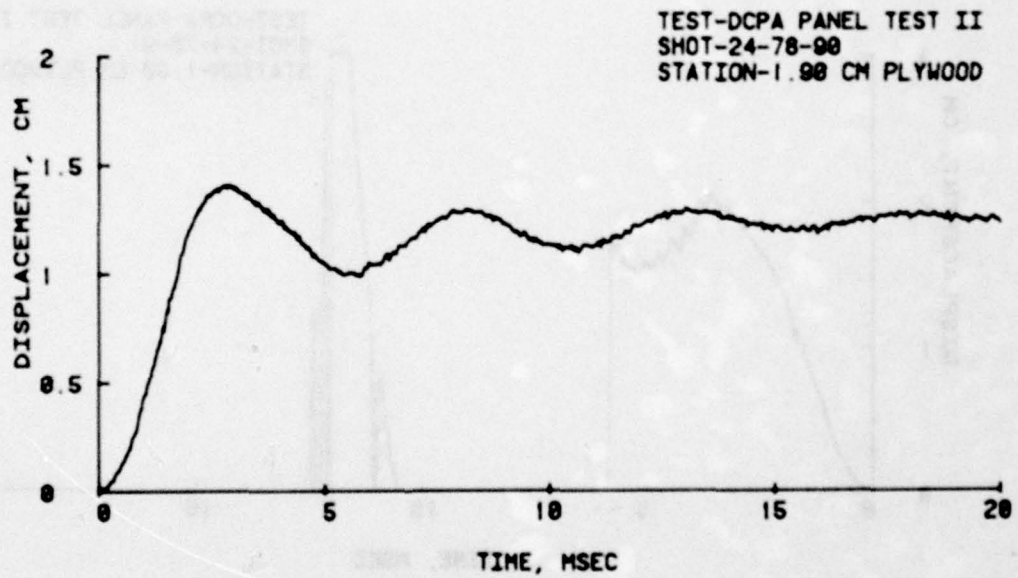
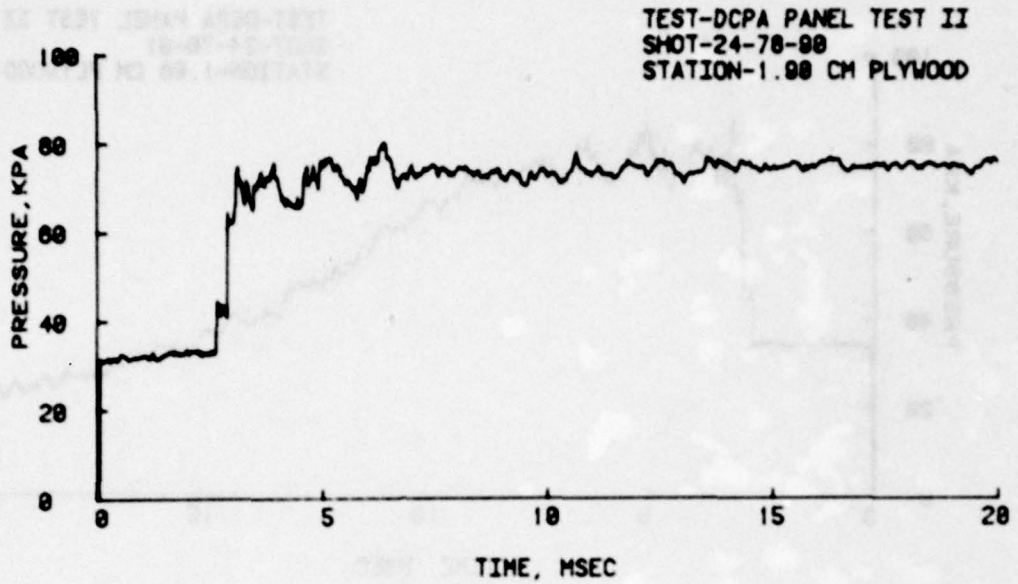

Figure A-3 (Cont). Records for 1.90 cm plywood sheet closures.

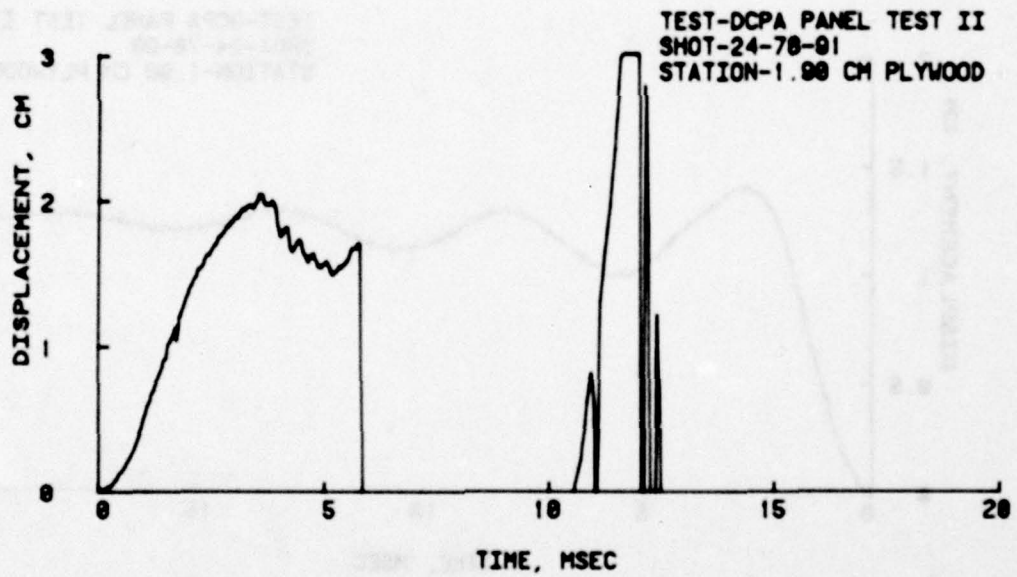
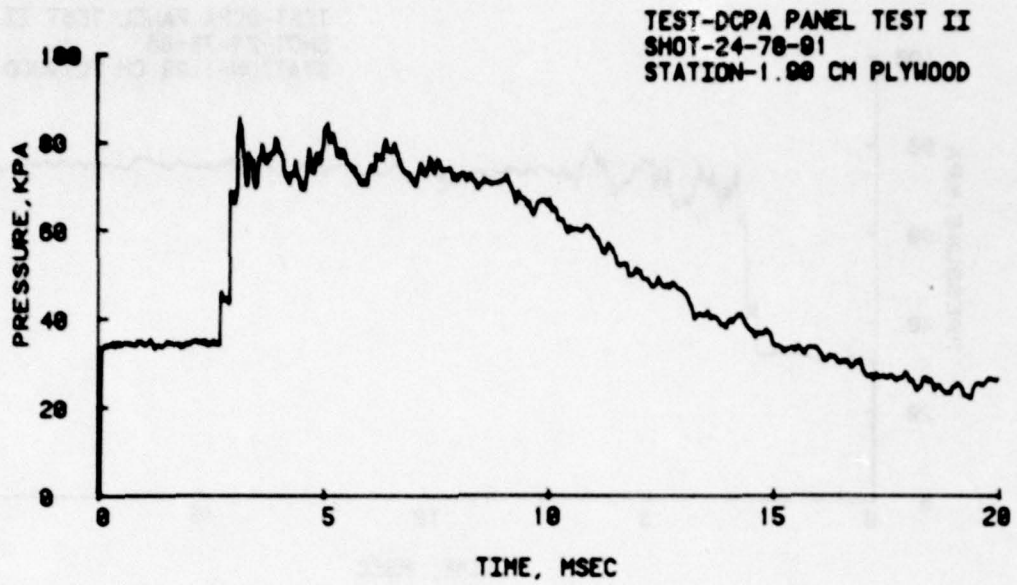

Figure A-3 (Cont). Records for 1.90 cm plywood sheet closures.

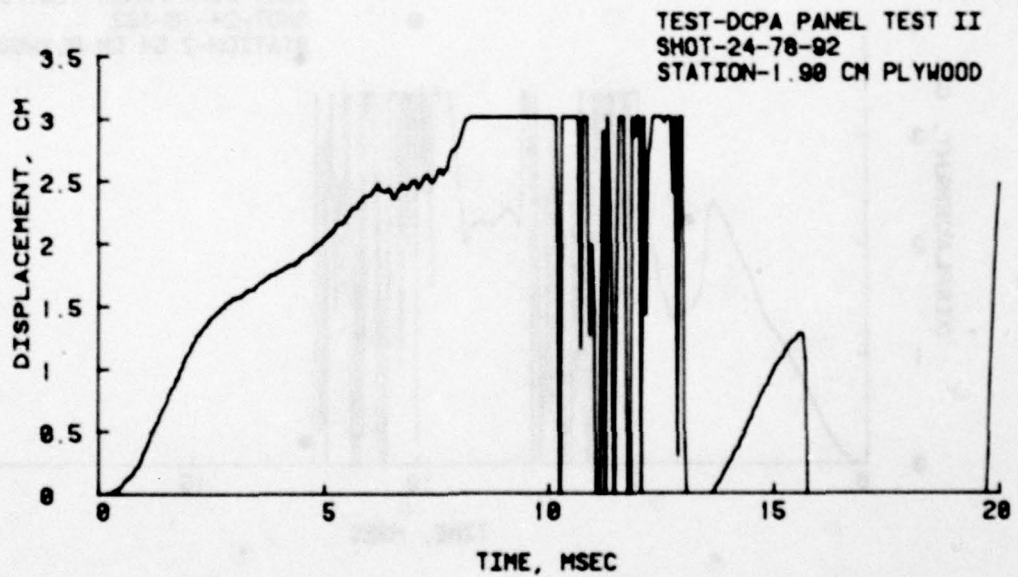
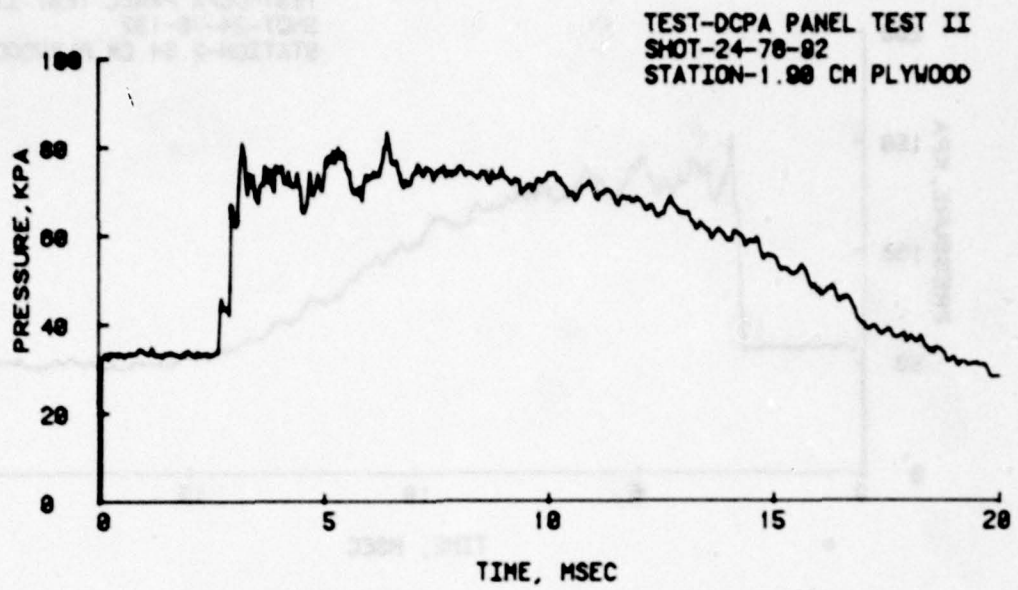

Figure A-3 (Cont). Records for 1.90 cm plywood sheet closures.

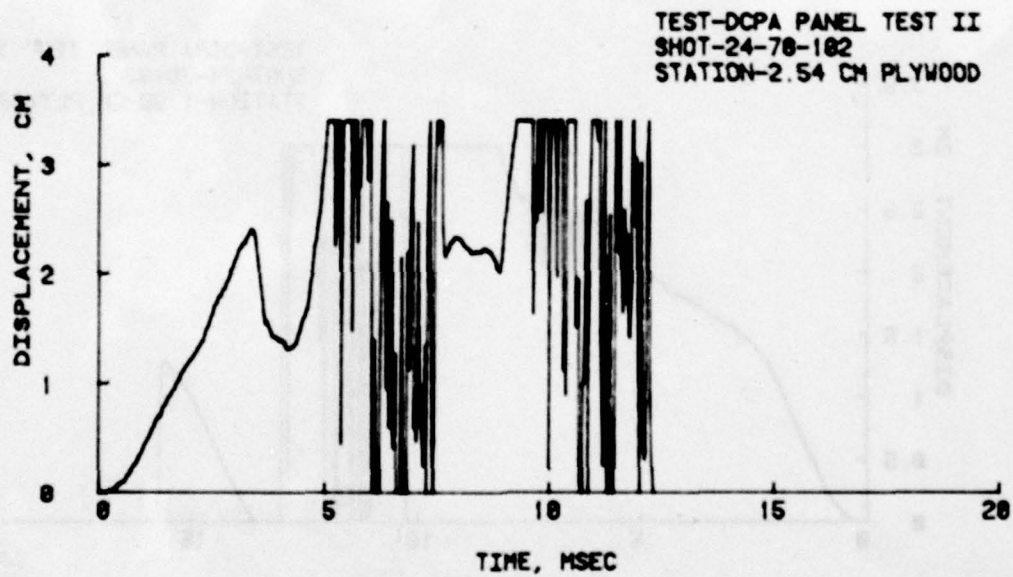
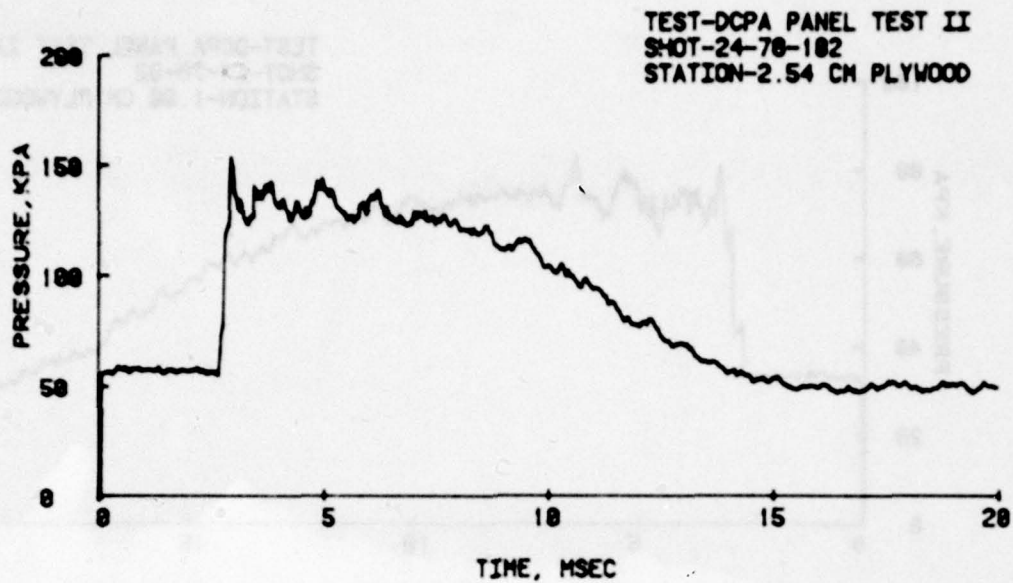

Figure A-4. Records for 2.54 cm plywood closures.

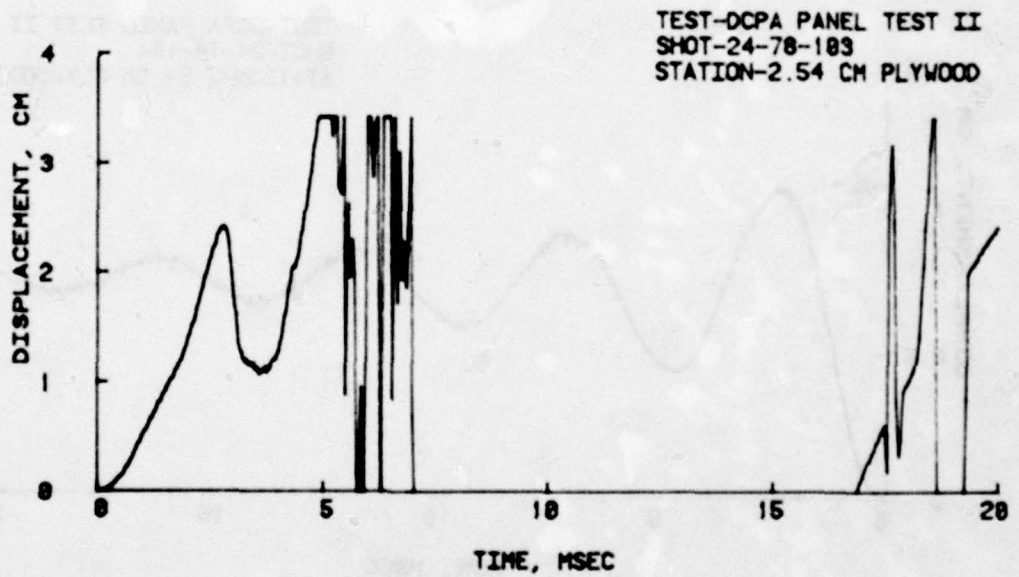
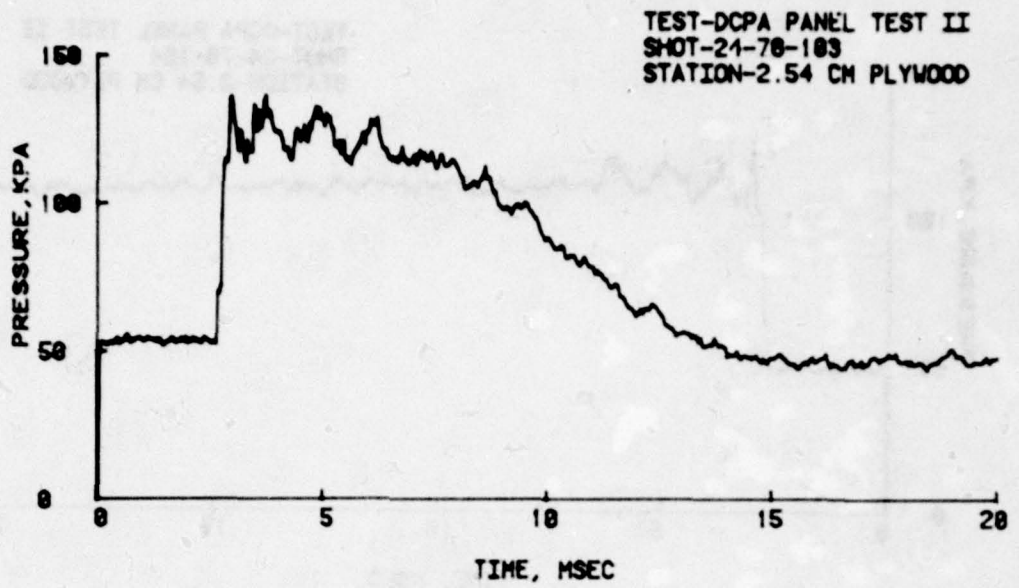

Figure A-4 (Cont). Records for 2.54 cm plywood closures.

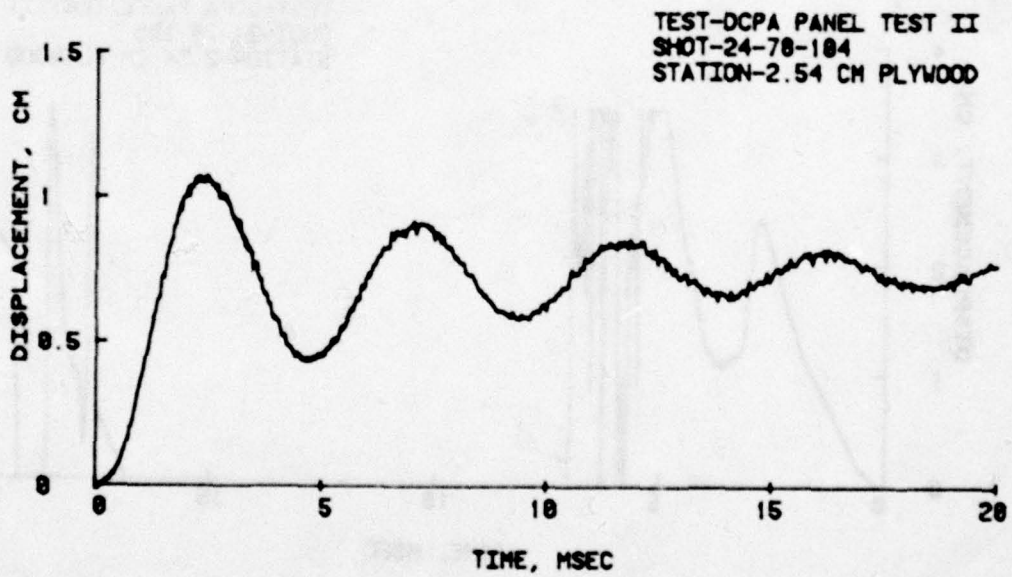
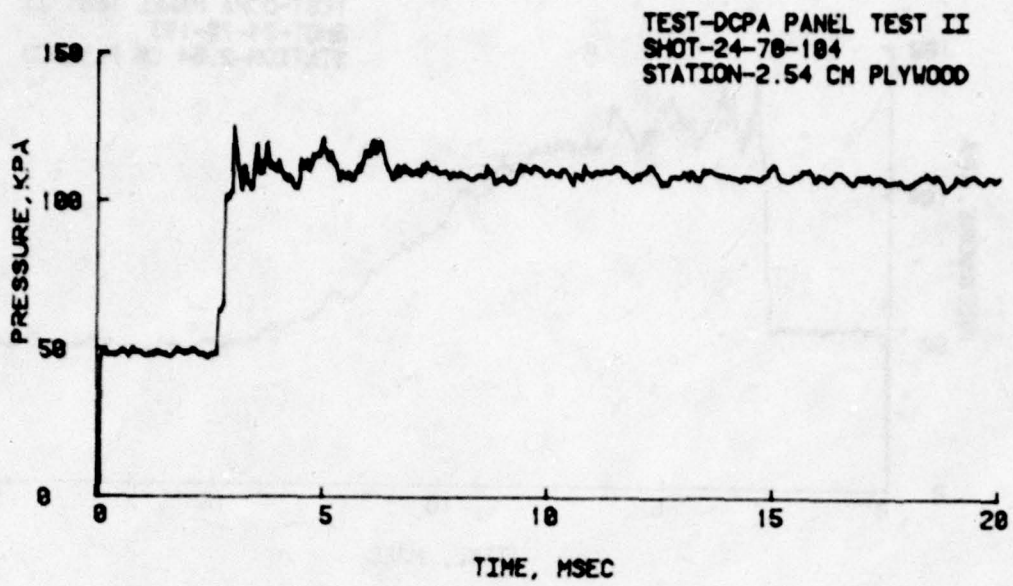

Figure A-4 (Cont). Records for 2.54 cm plywood closures.

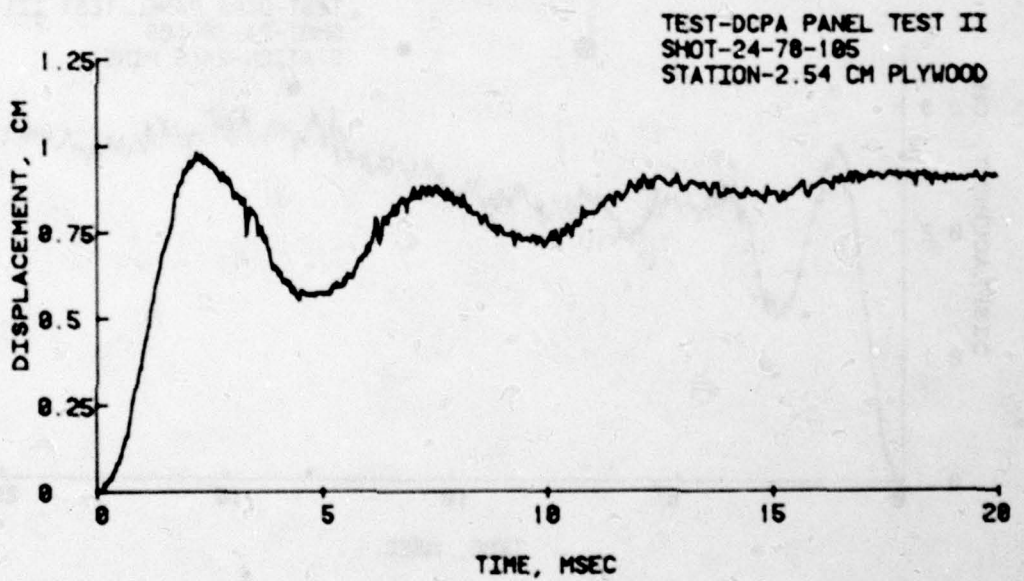
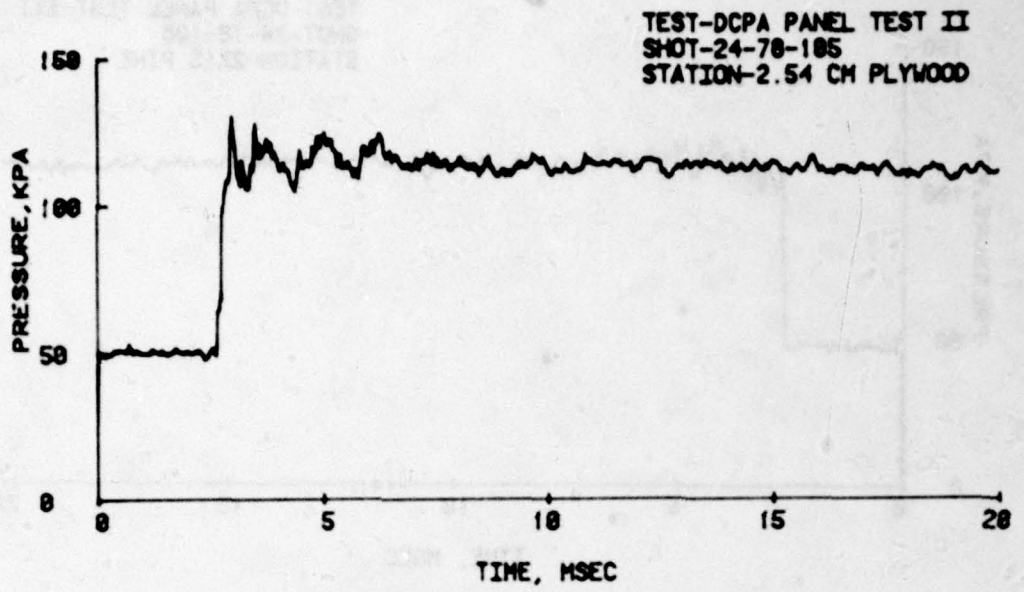

Figure A-4 (Cont). Records for 2.54 cm plywood closures.

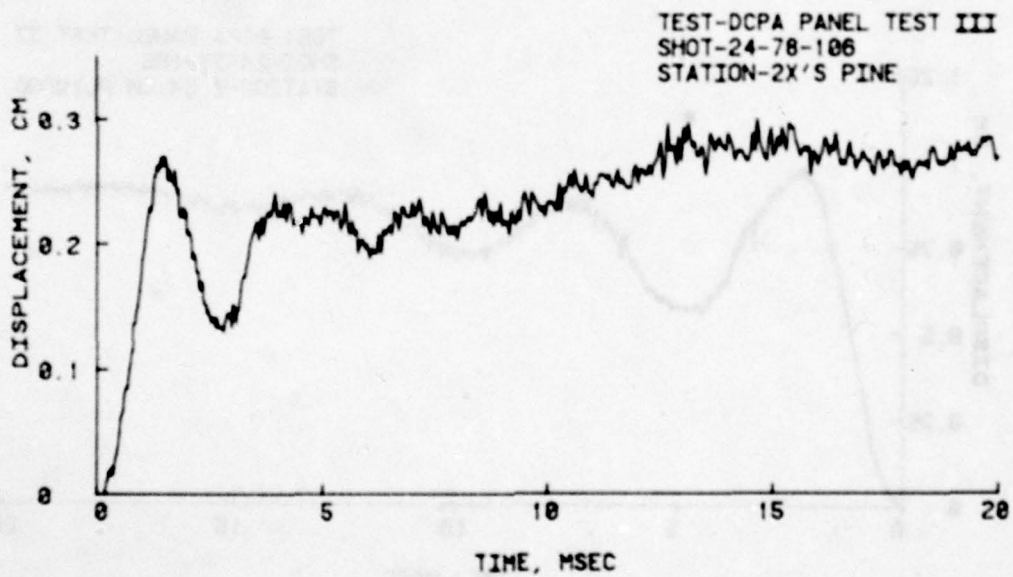
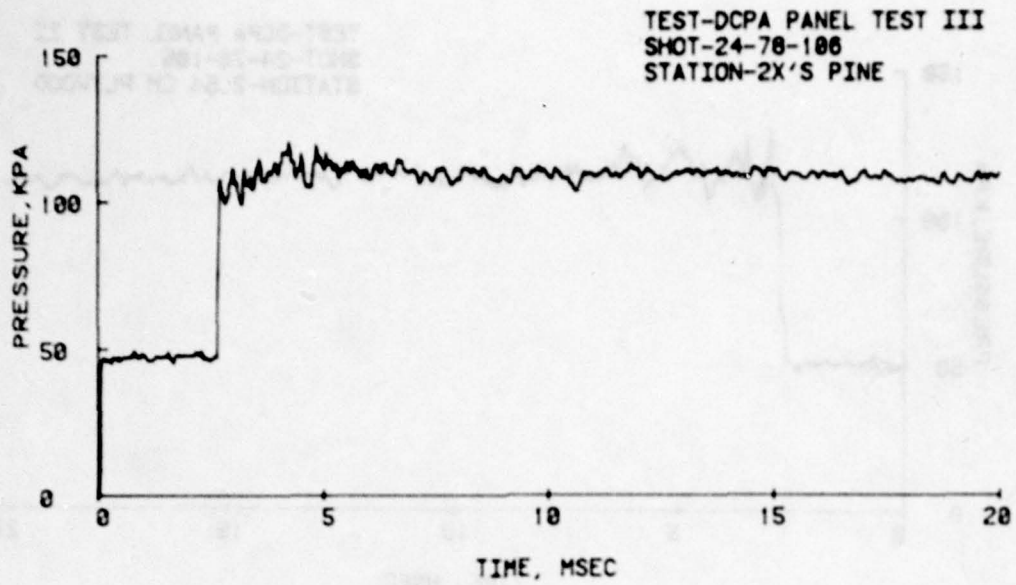

Figure A-5. Records for 2x's placed flat.

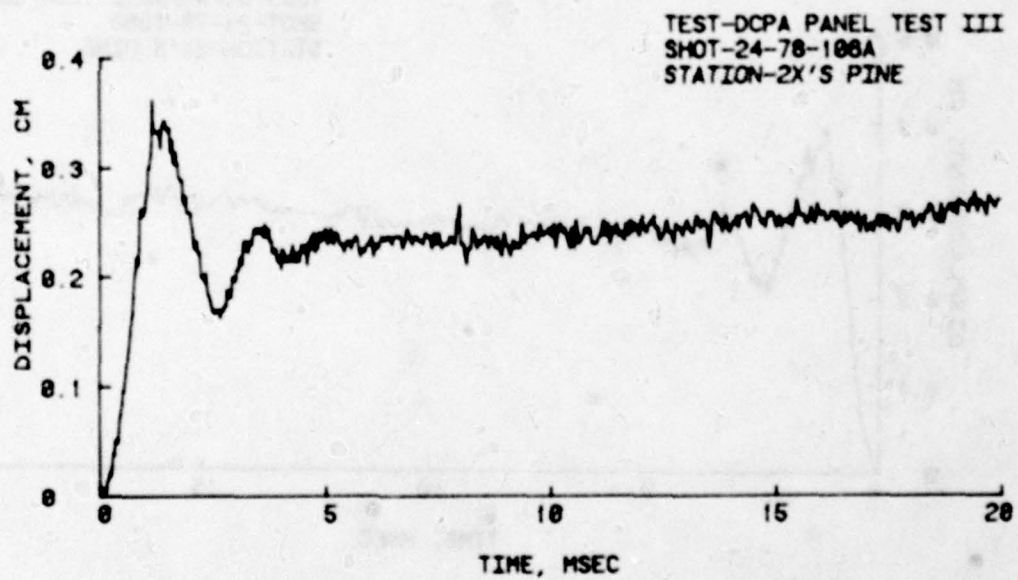
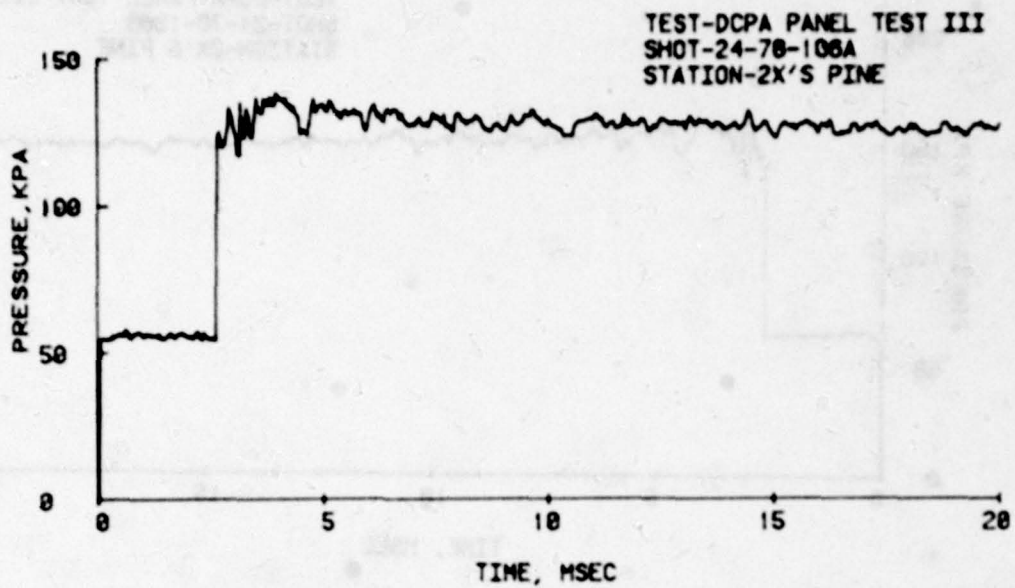

Figure A-5 (Cont). Records for 2x's placed flat.

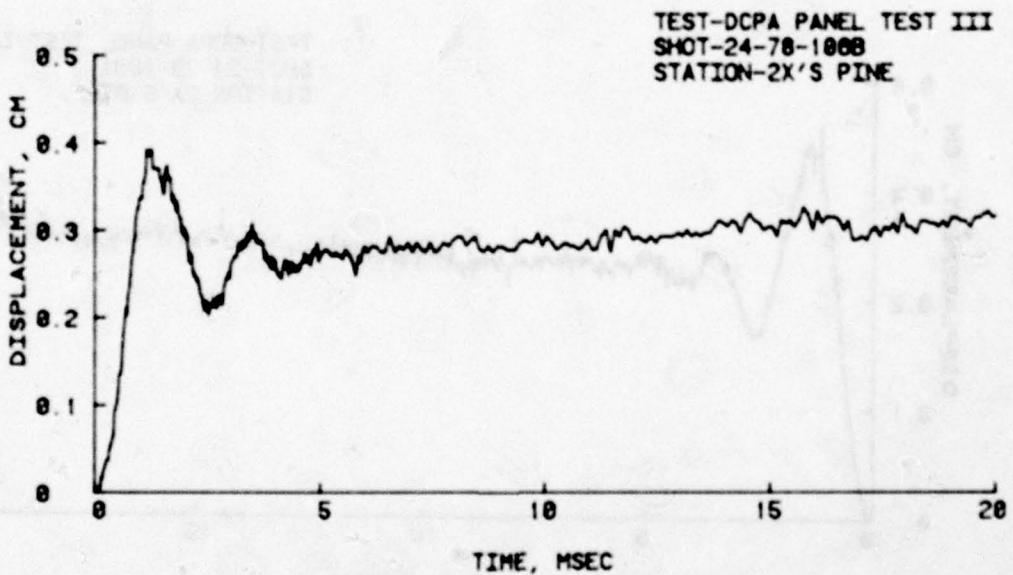
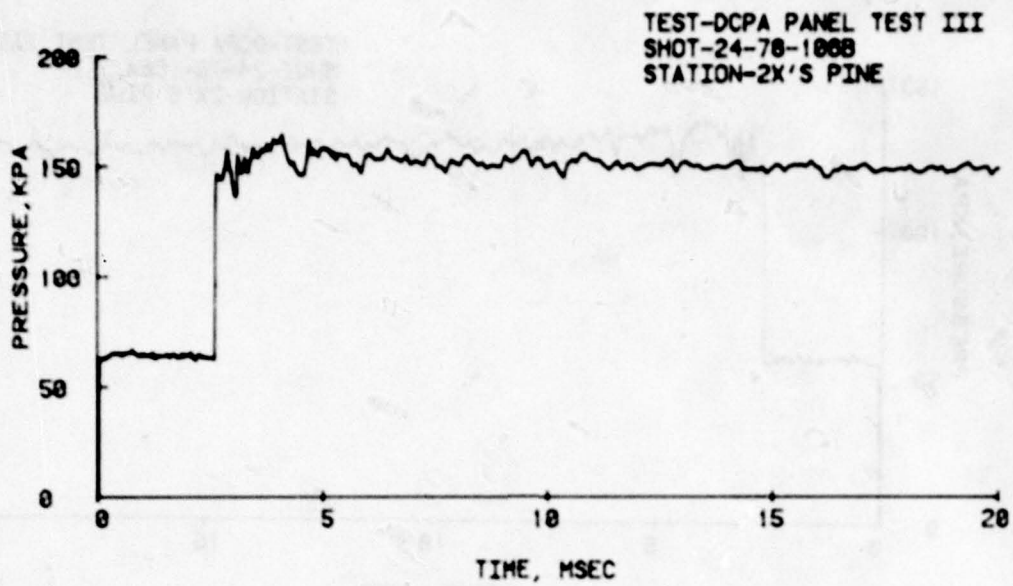

Figure A-5 (Cont). Records for 2x's placed flat.

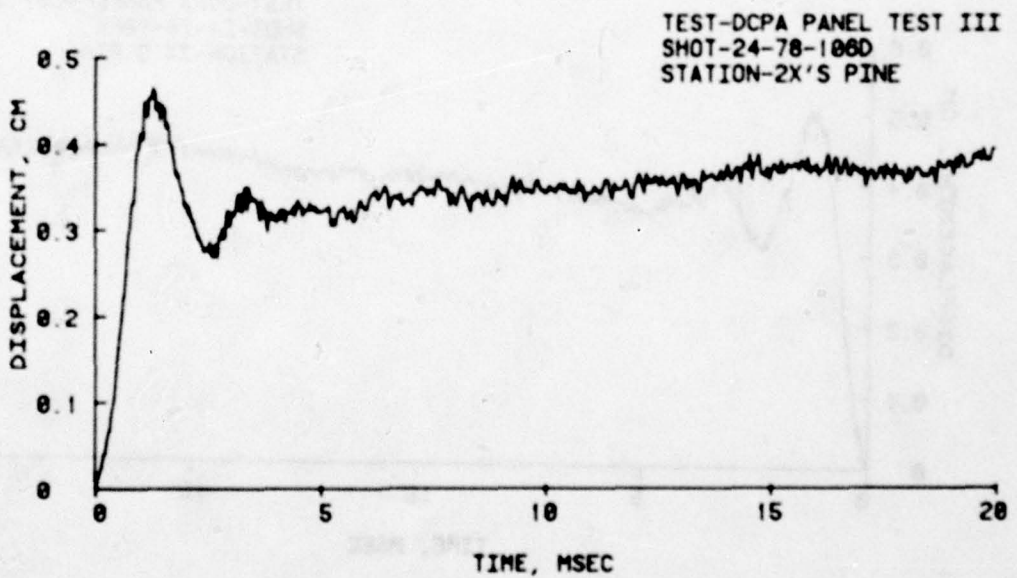
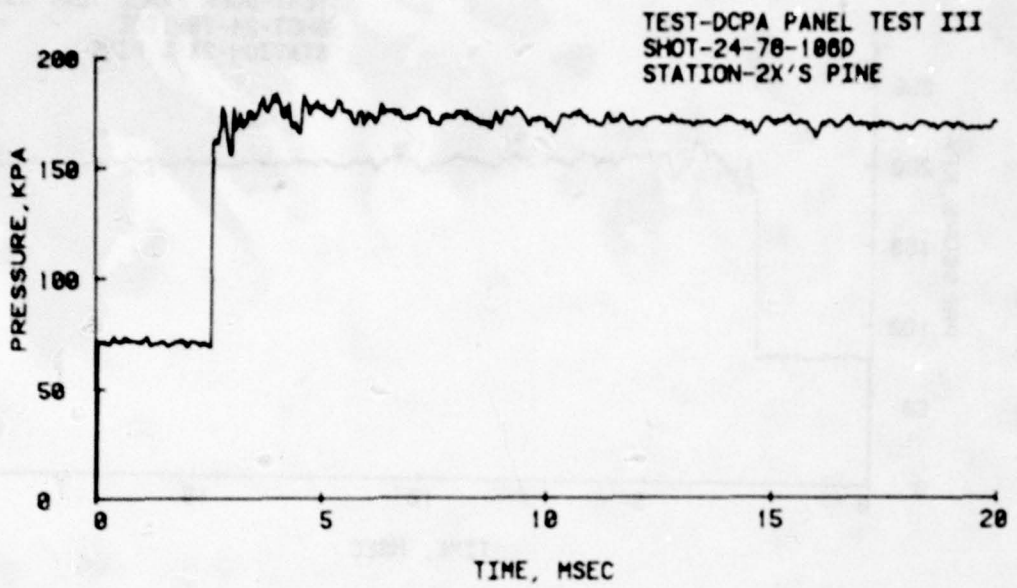

Figure A-5 (Cont). Records for 2x's placed flat.

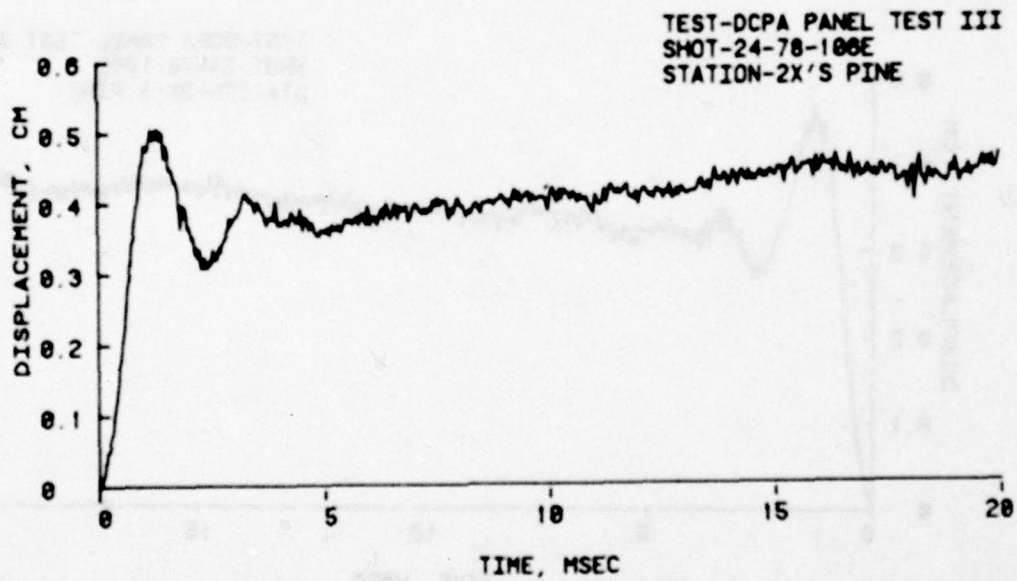
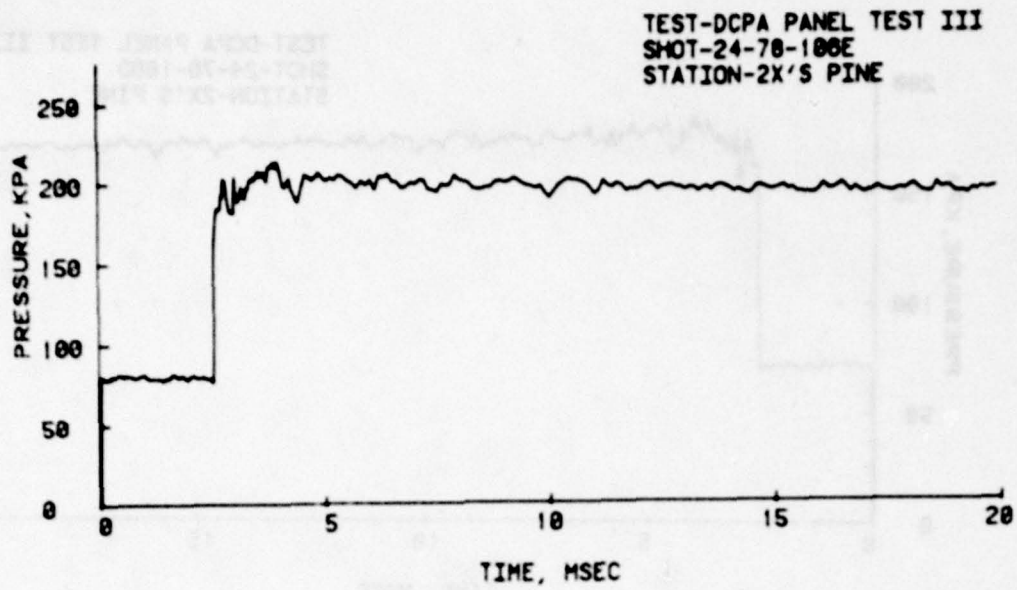

Figure A-5 (Cont). Records for 2x's placed flat.

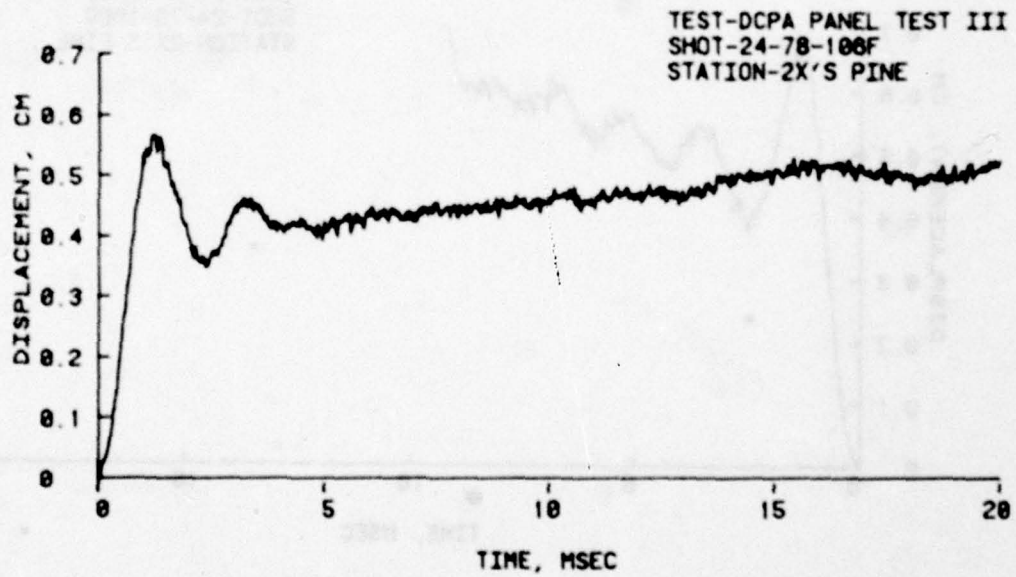
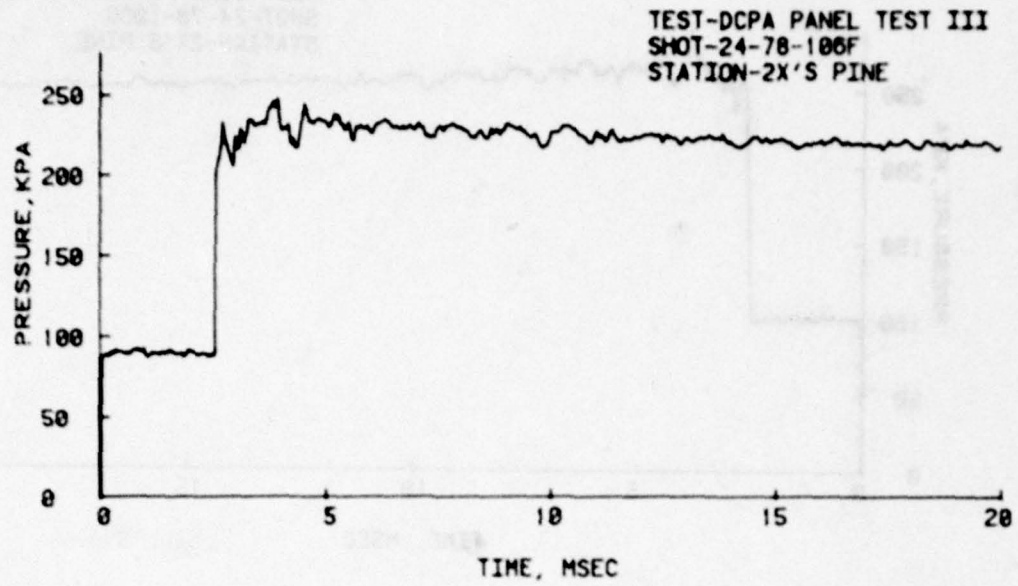

Figure A-5 (Cont). Records for 2x's placed flat.

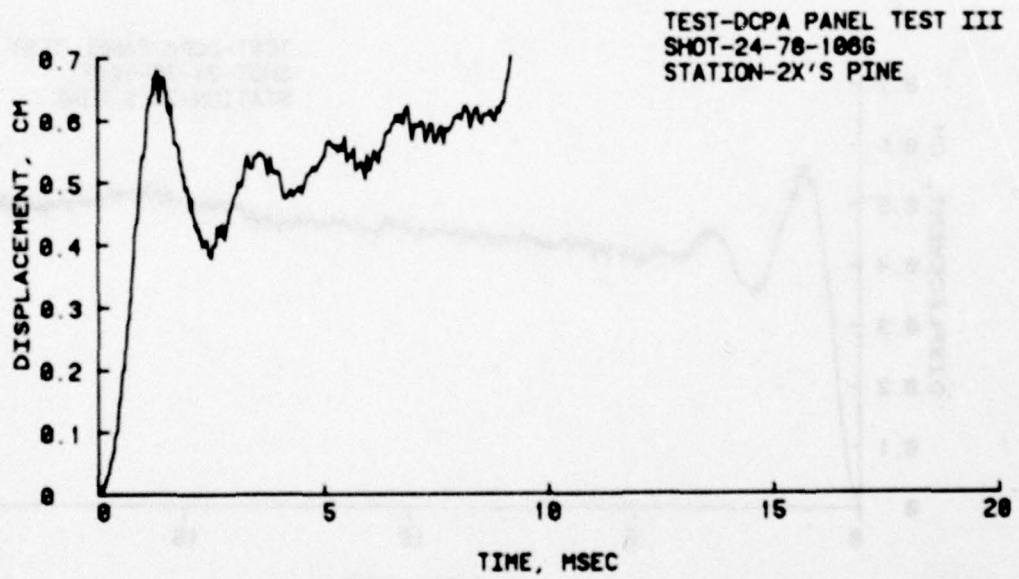
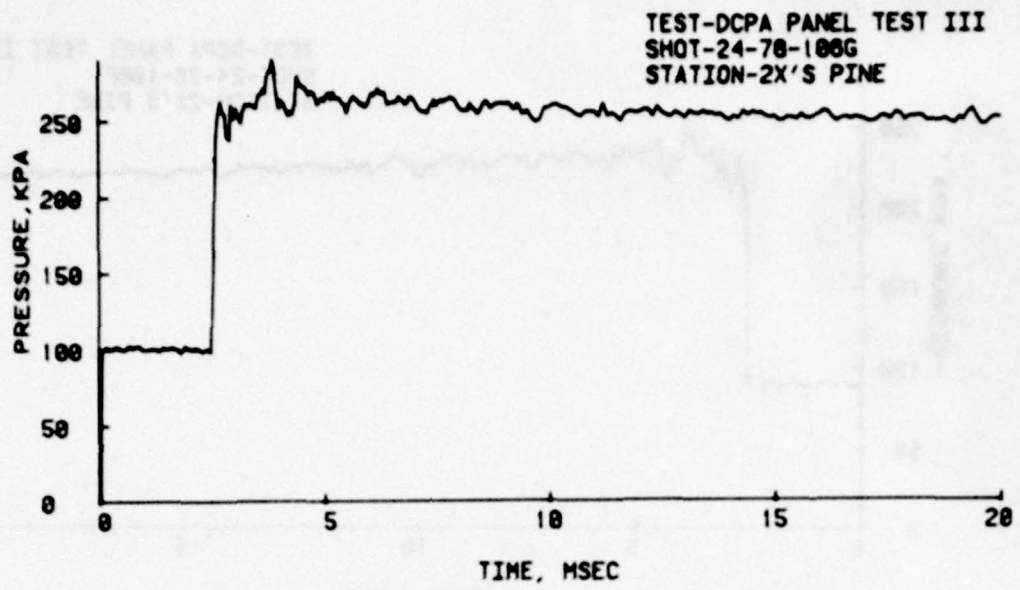

Figure A-5 (Cont). Records for 2x's placed flat.

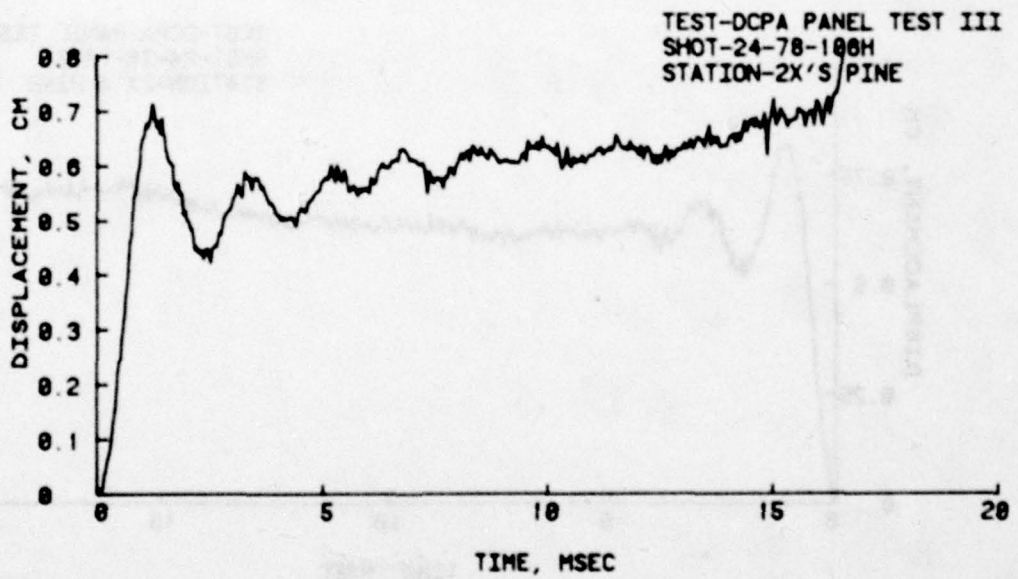
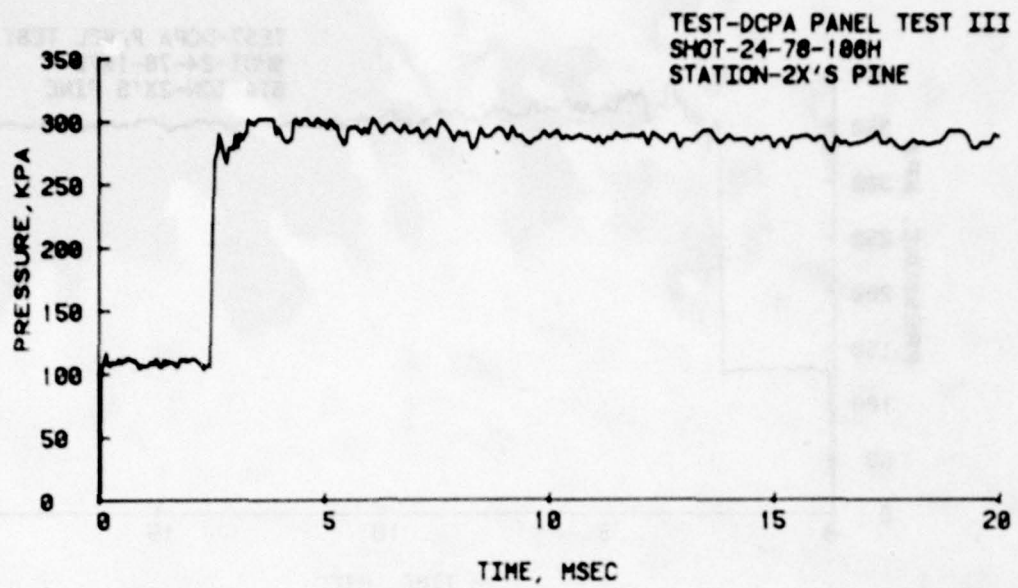

Figure A-5 (Cont). Records for 2x's placed flat.

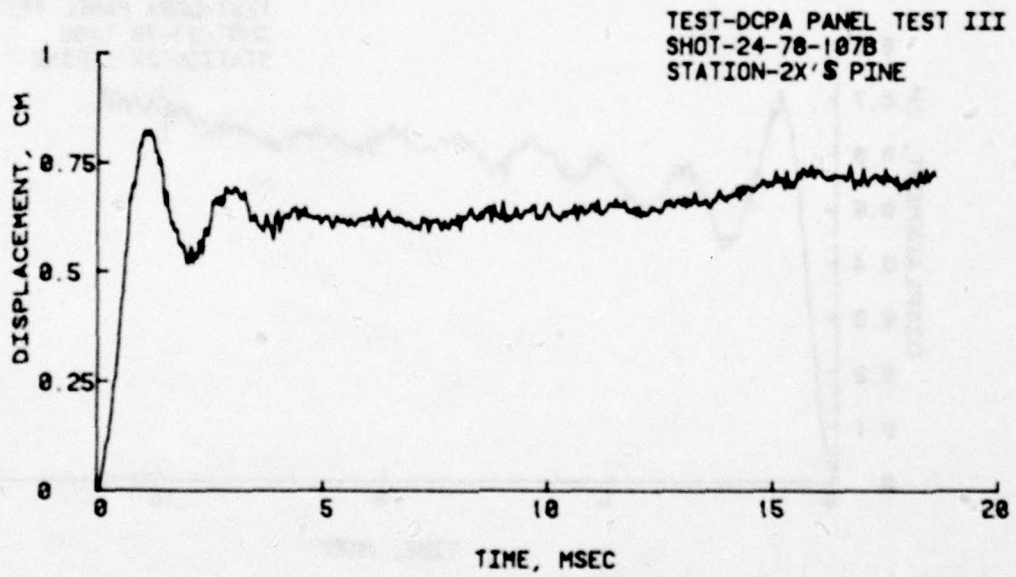
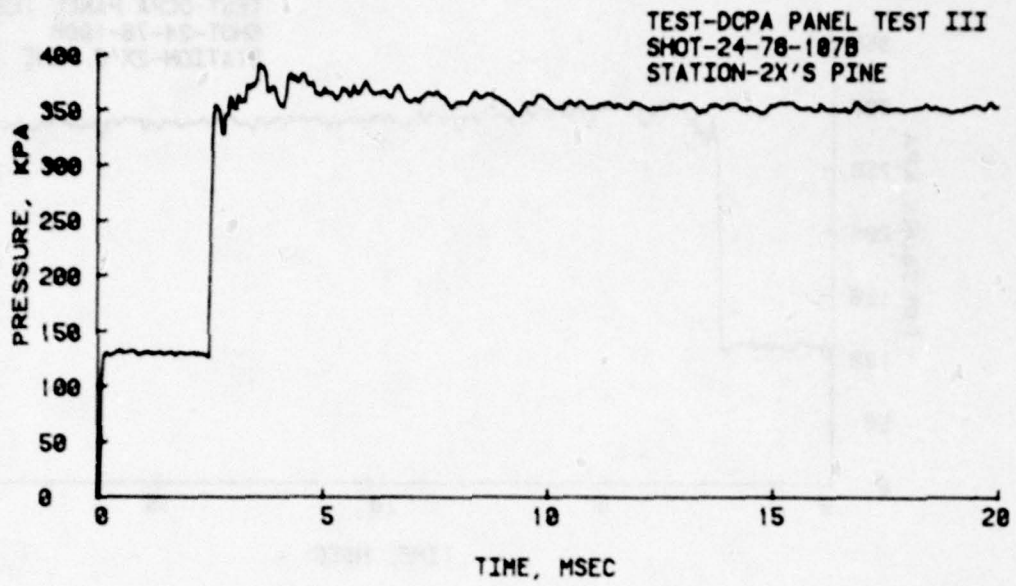

Figure A-5 (Cont). Records for 2x's placed flat.

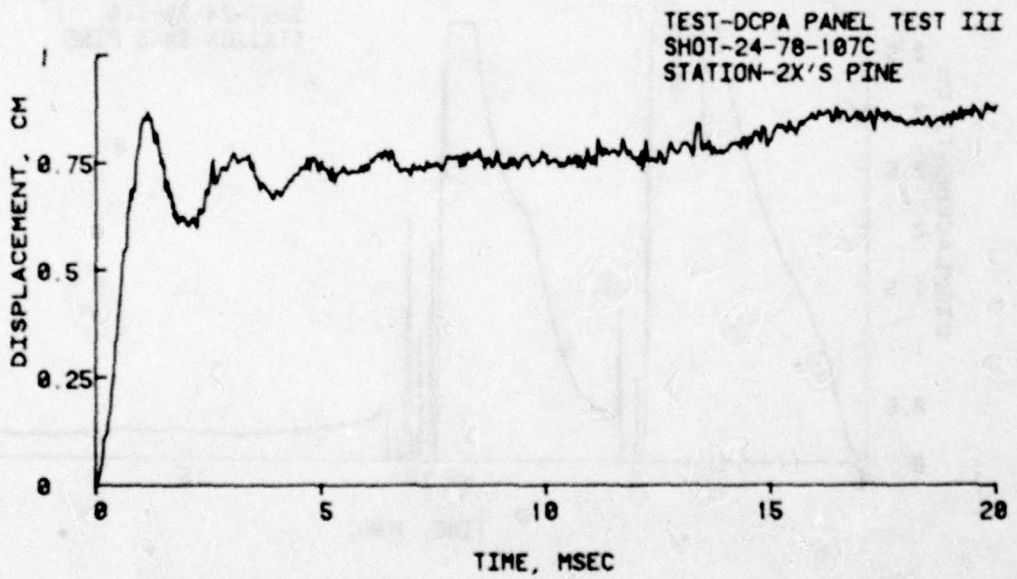
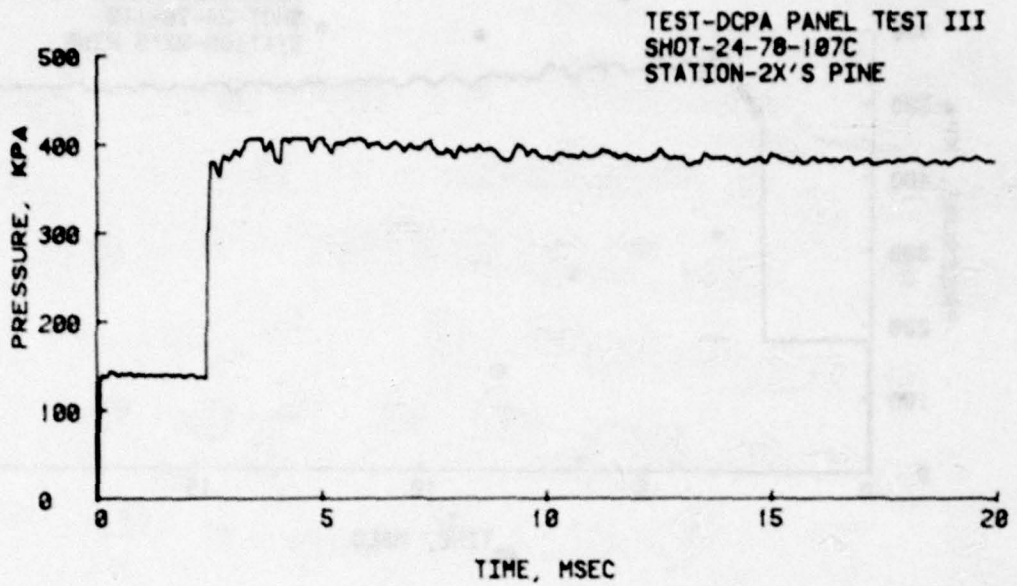

Figure A-5 (Cont). Records for 2x's placed flat.

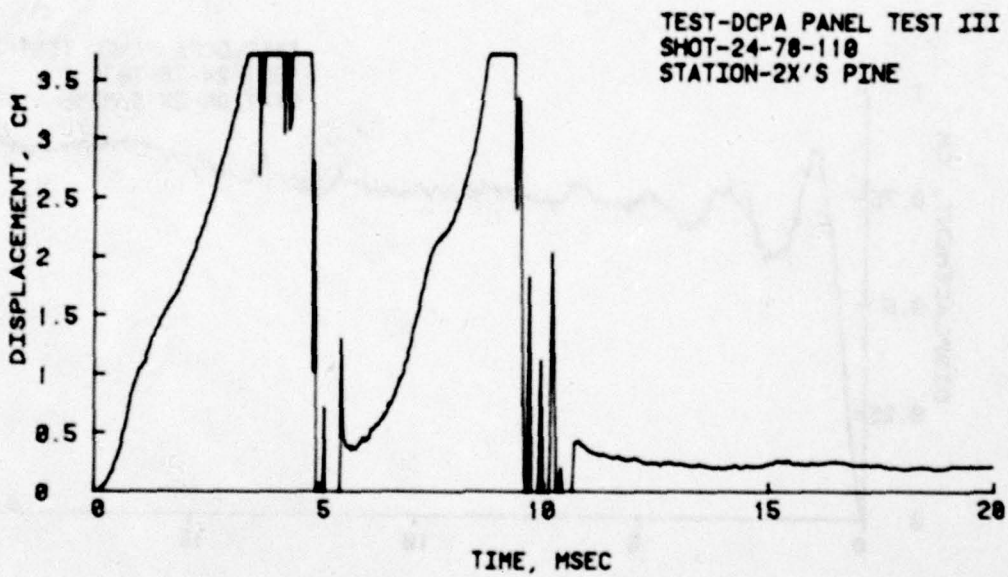
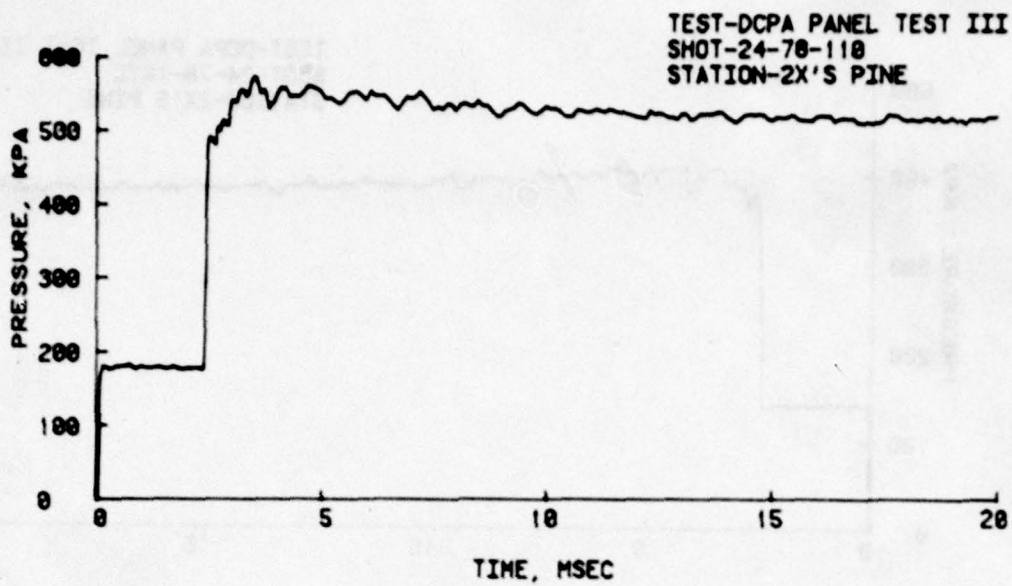

Figure A-5 (Cont). Records for 2x's placed flat.

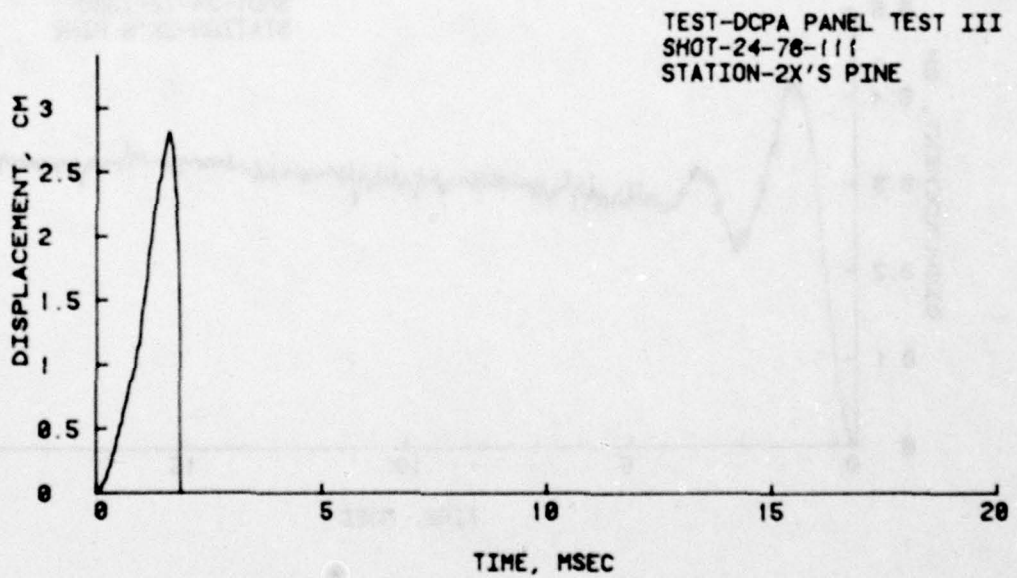
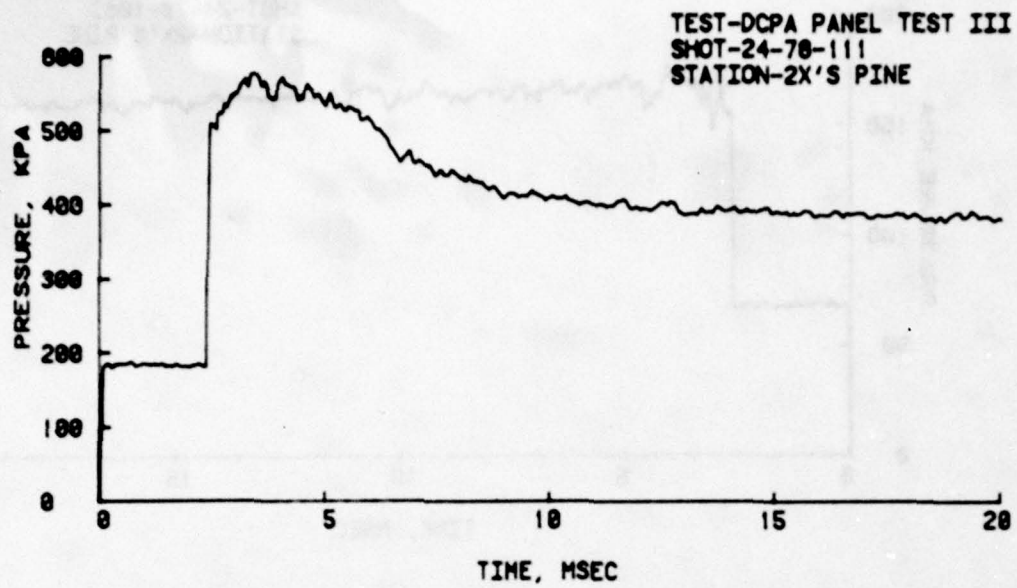

Figure A-5 (Cont). Records for 2x's placed flat.

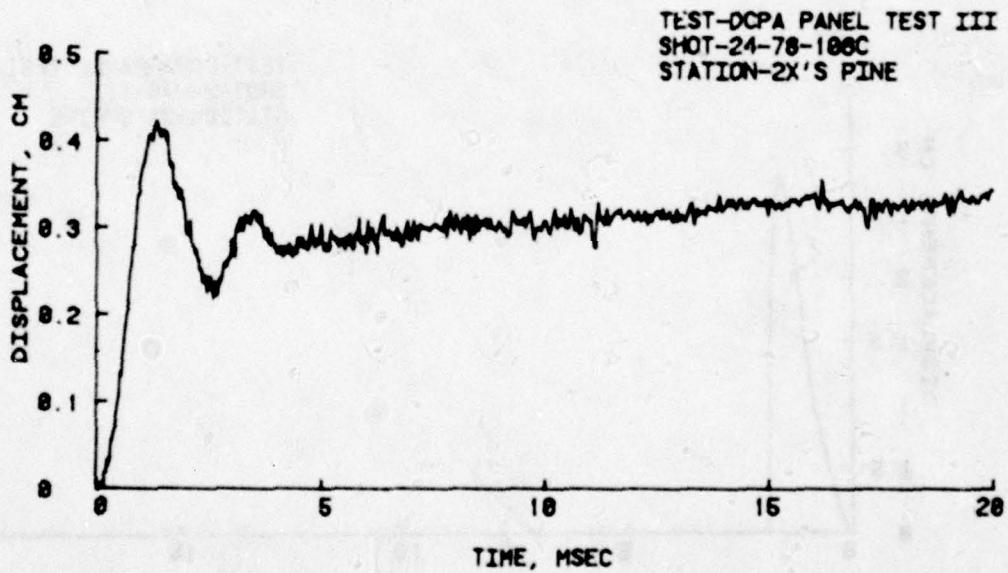
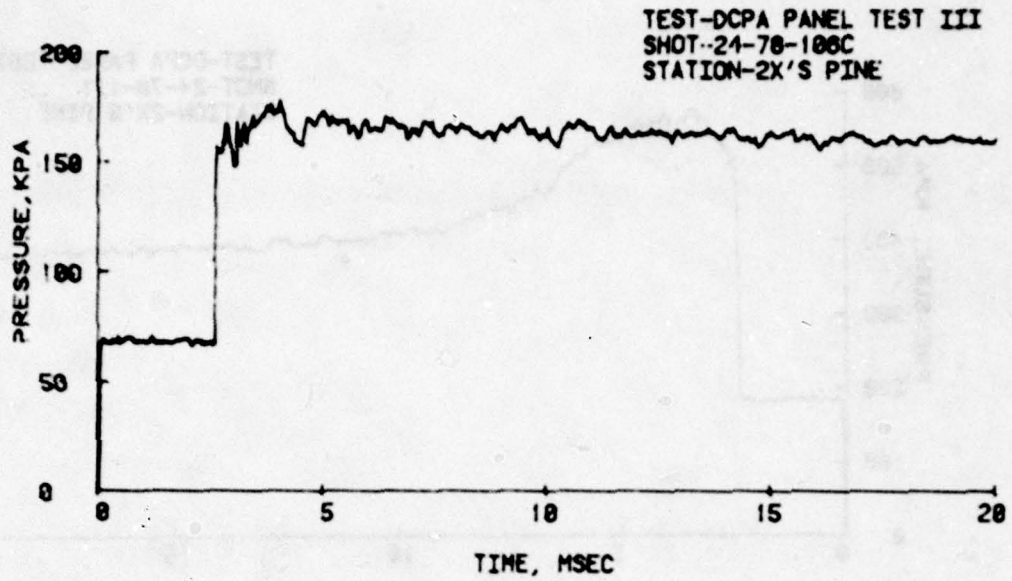

Figure A-5 (Cont). Records for 2x's placed flat.

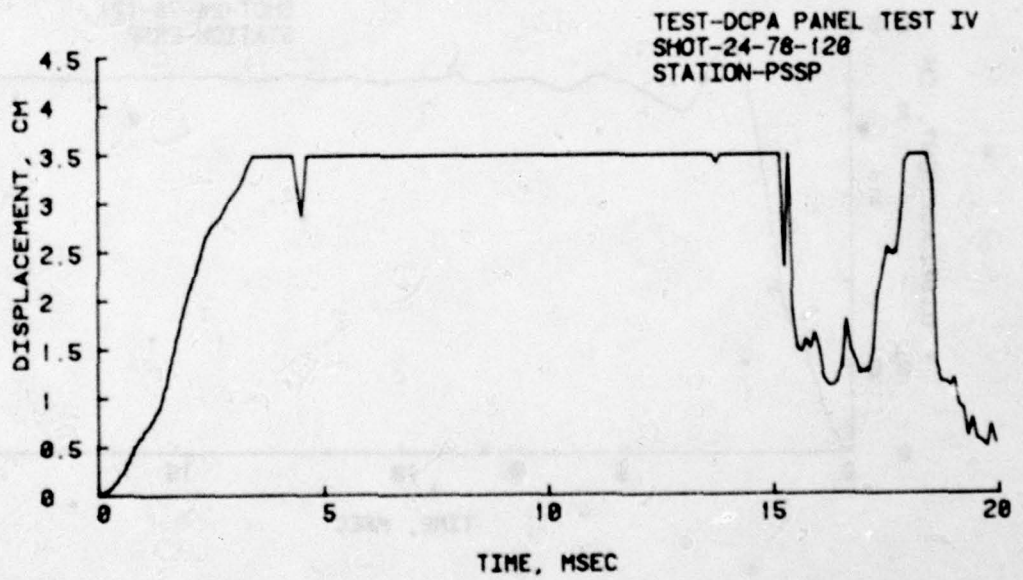
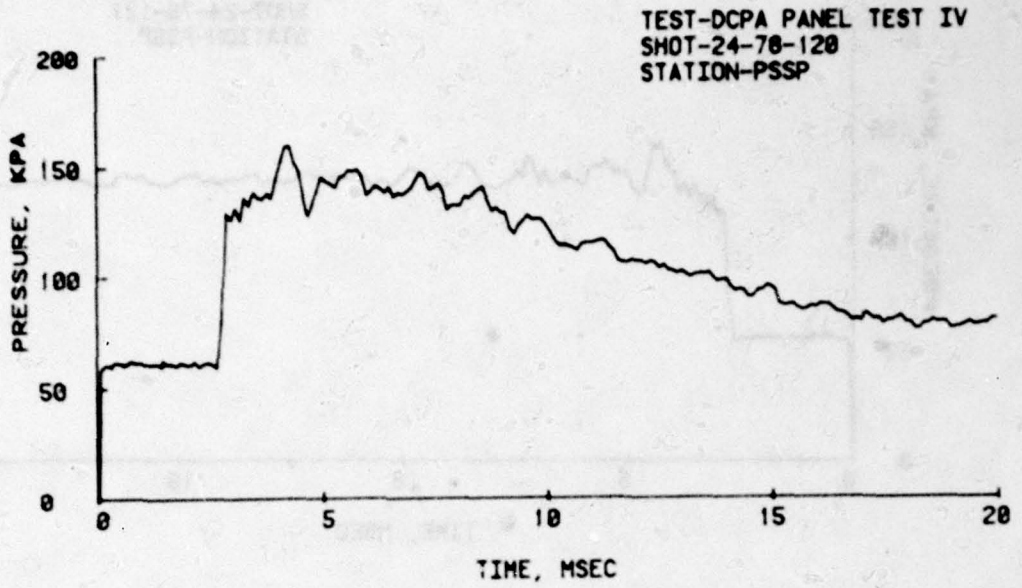

Figure A-6. Records for PSSP closures with plywood skins not glued.

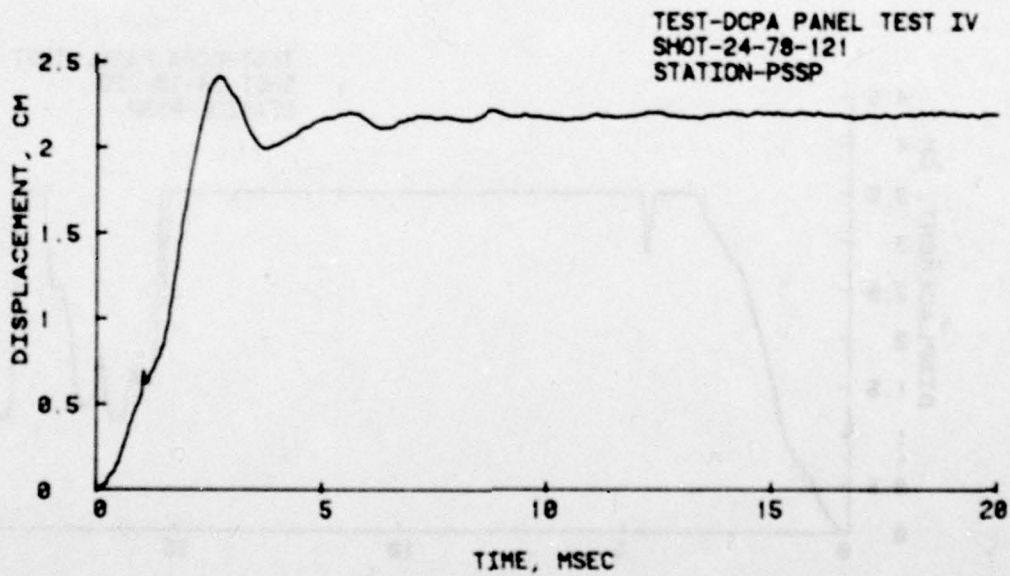
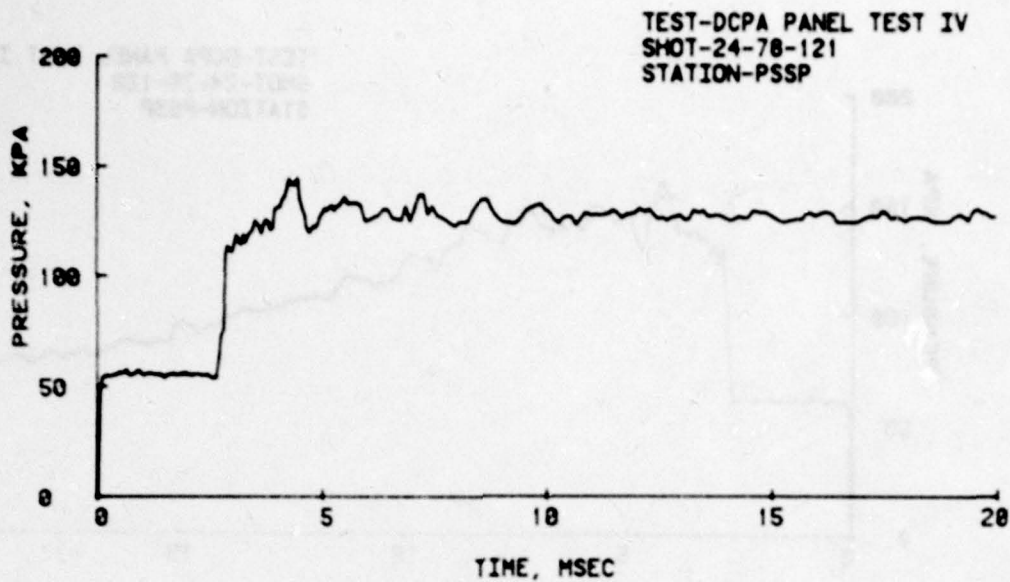

Figure A-6 (Cont). Records for PSSP closures with plywood skins not glued.

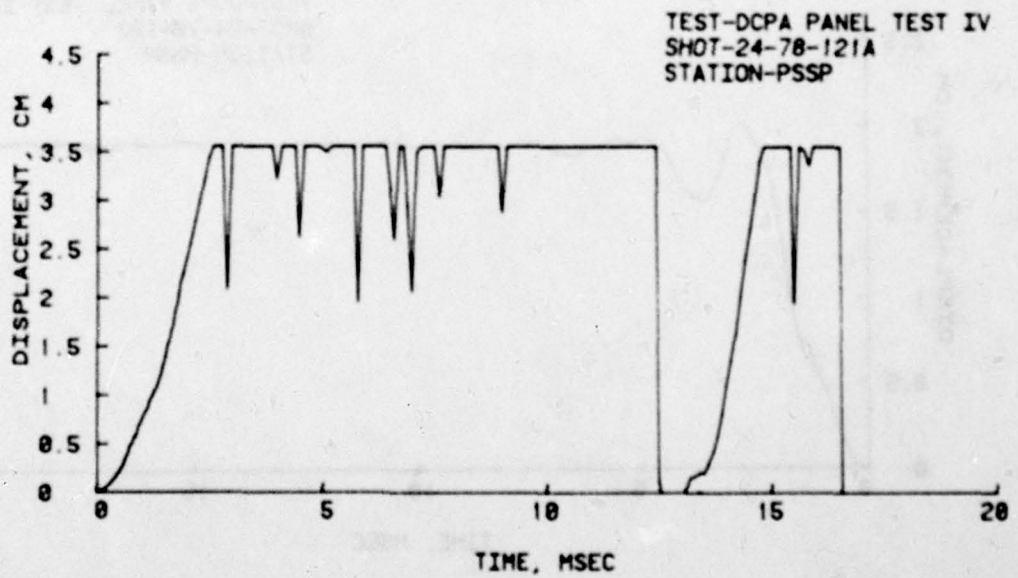
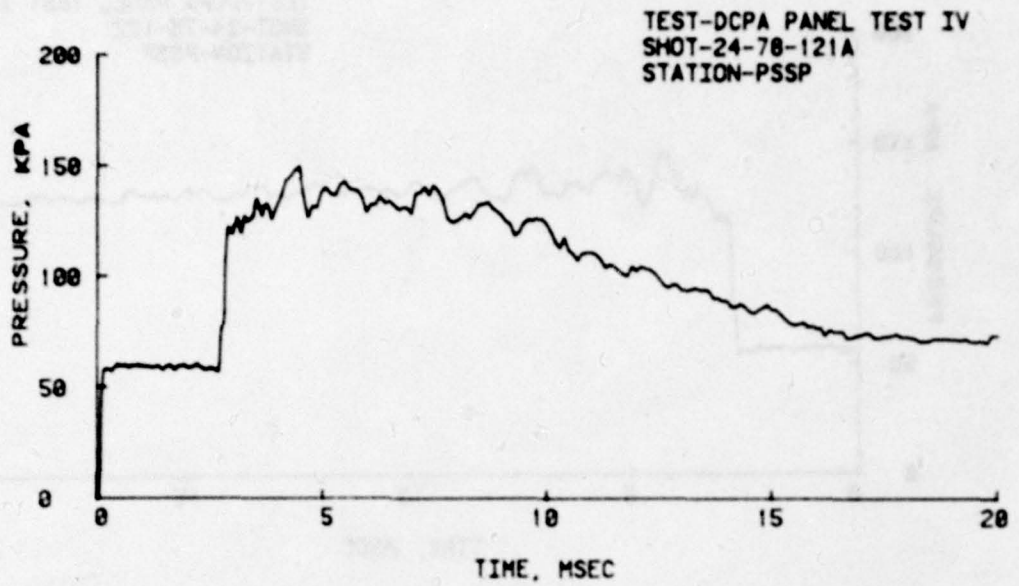

Figure A-6 (Cont). Records for PSSP closures
with plywood skins not glued.

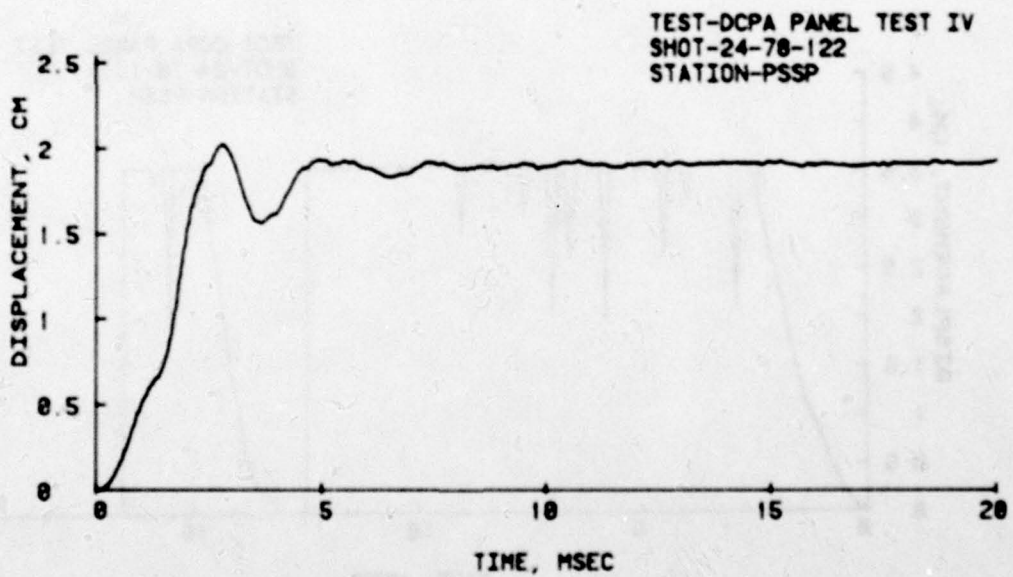
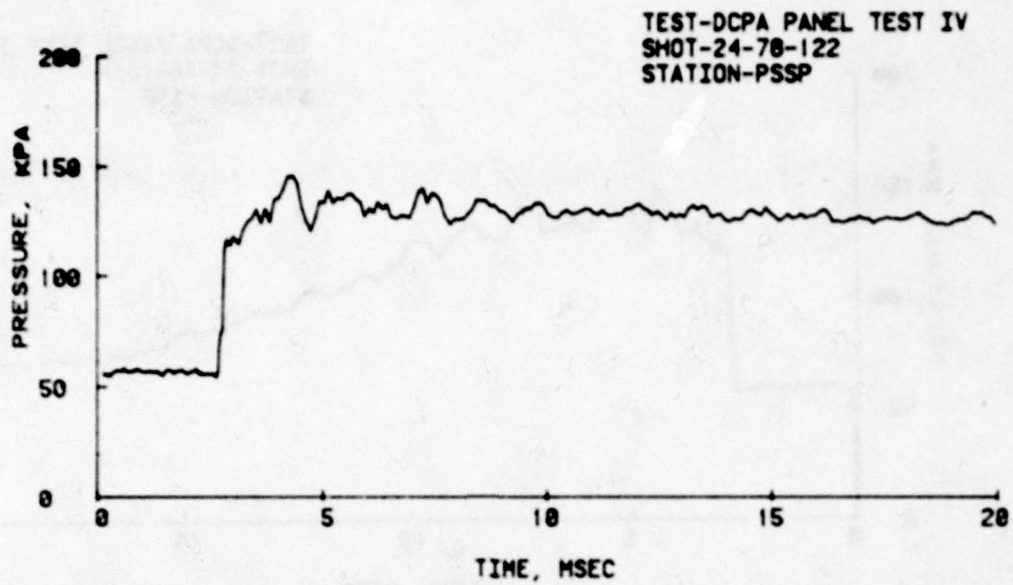

Figure A-6 (Cont). Records for PSSP closures with plywood skins not glued.

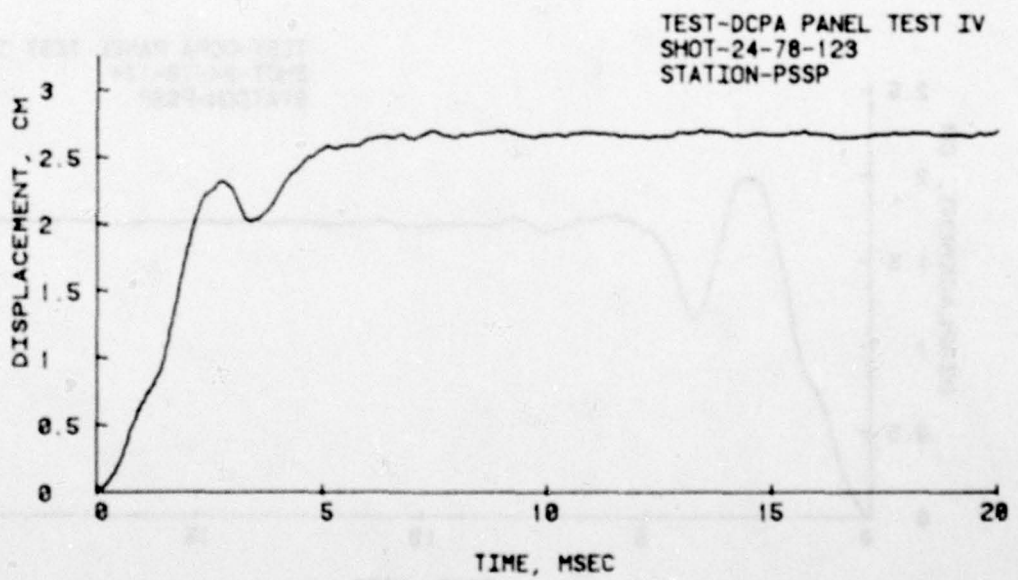
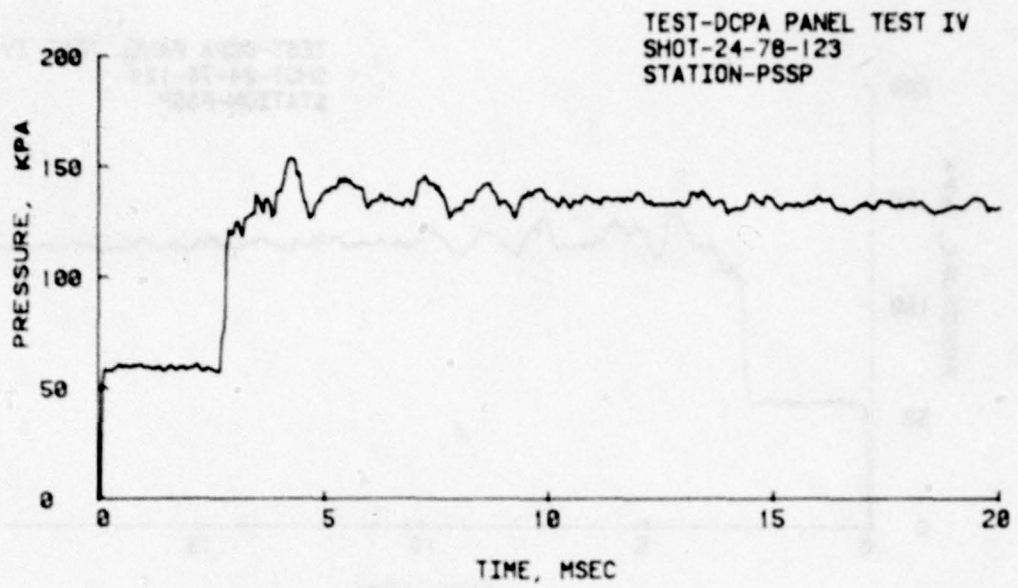

Figure A-6 (Cont). Records for PSSP closures with plywood skins not glued.

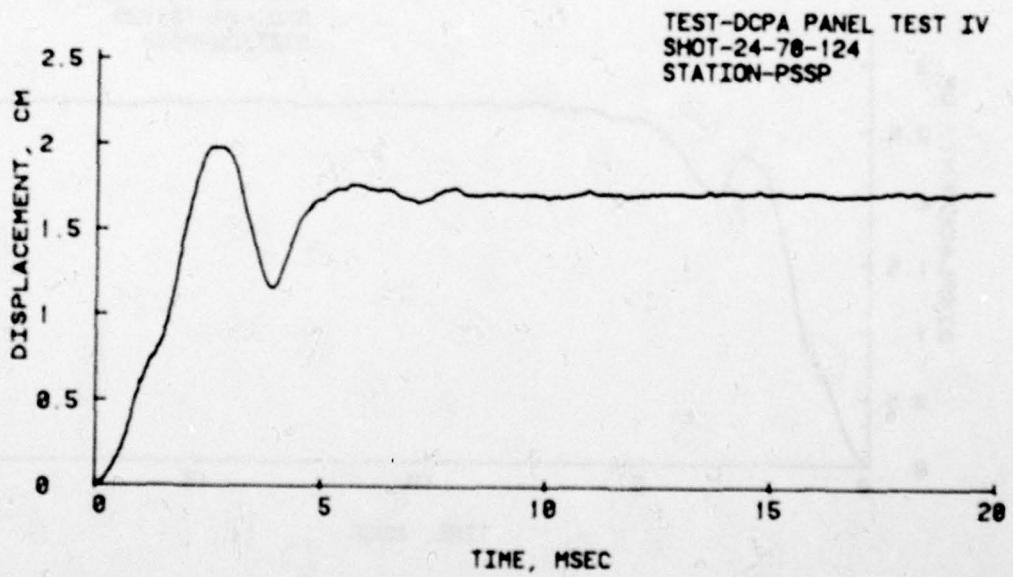
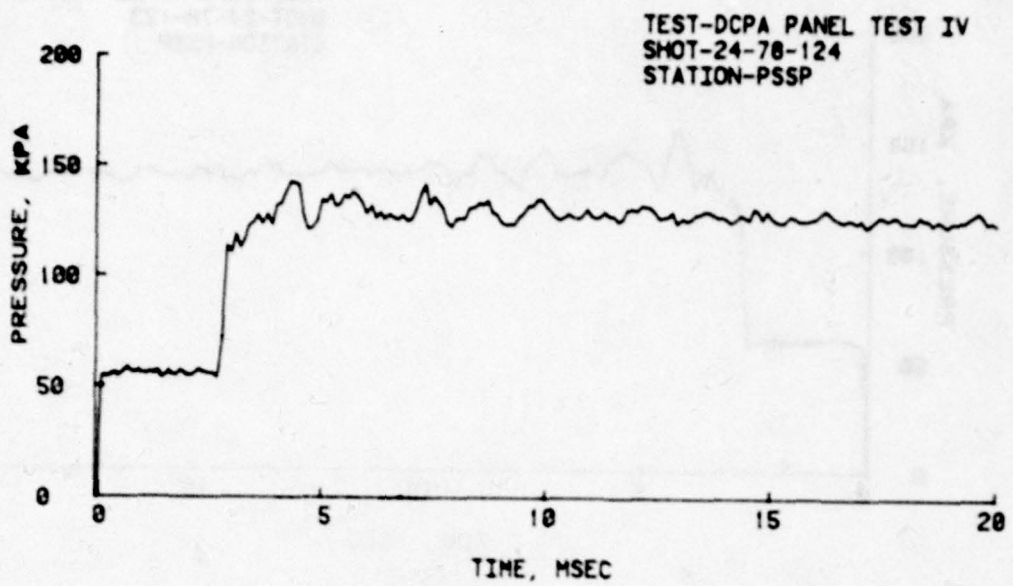

Figure A-6 (Cont). Records for PSSP closures with plywood skins not glued.

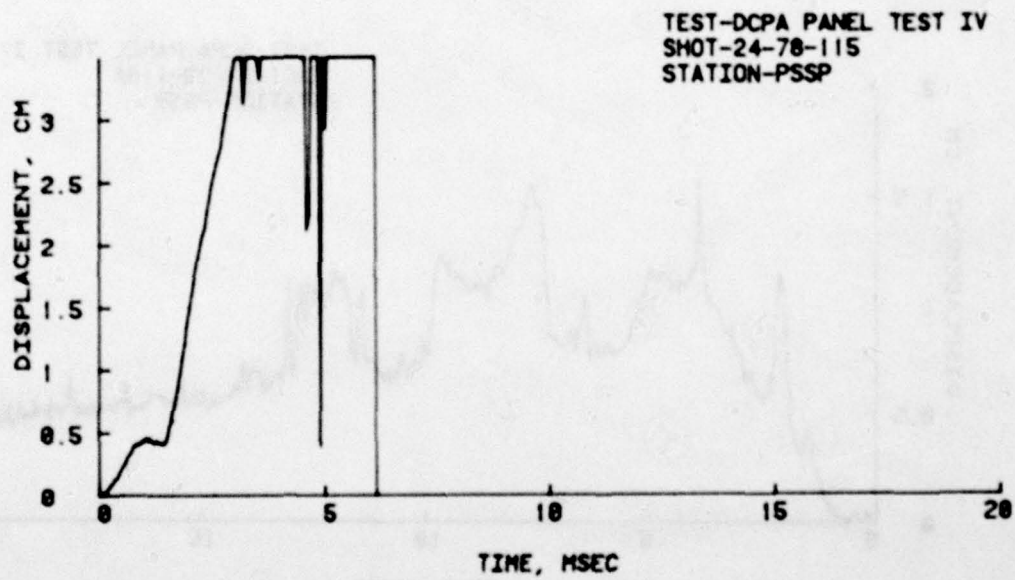
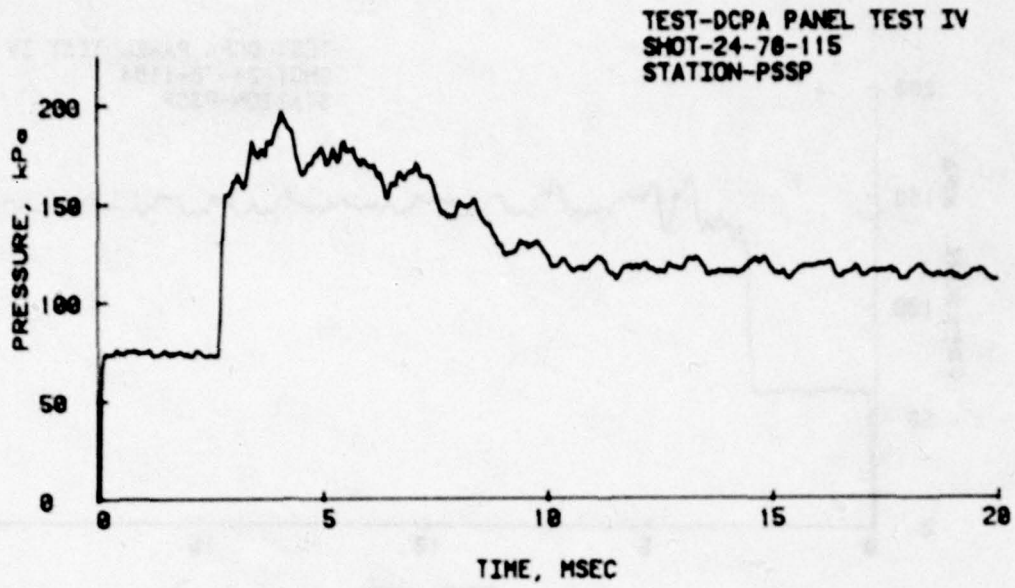

Figure A-7. Records for PSSP closures with plywood skins glued.

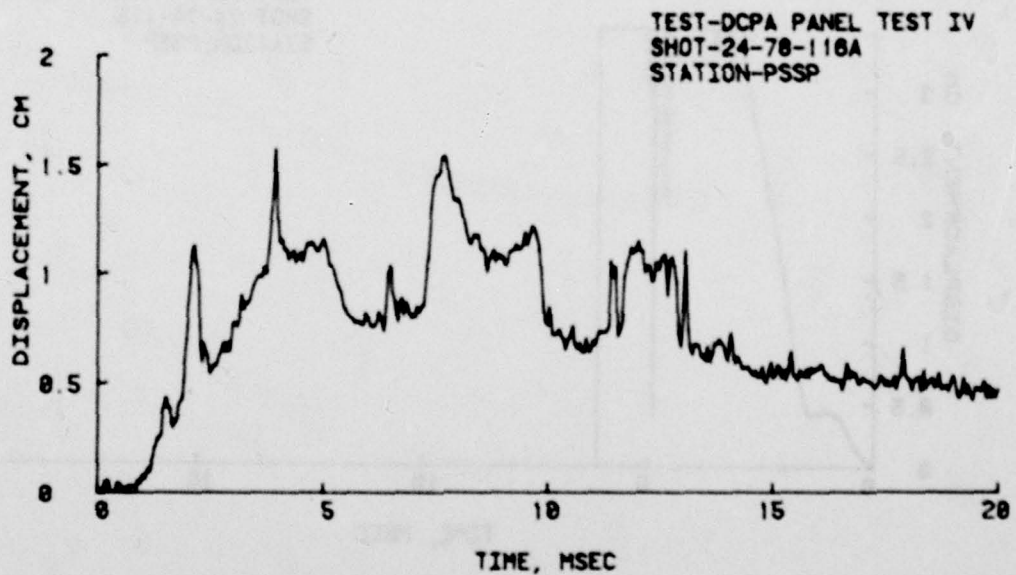
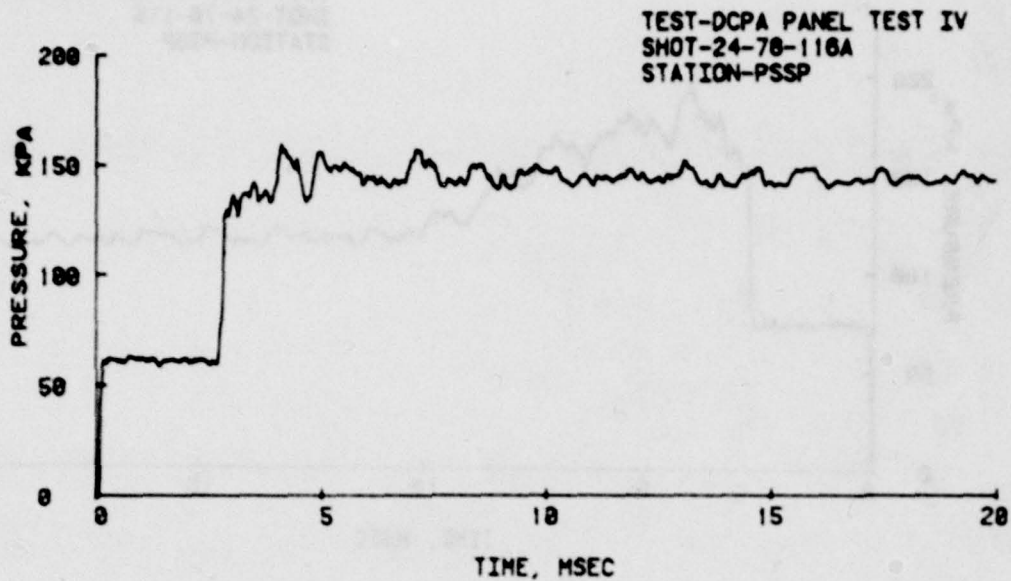

Figure A-7 (Cont). Records for PSSP closures with plywood skins glued.

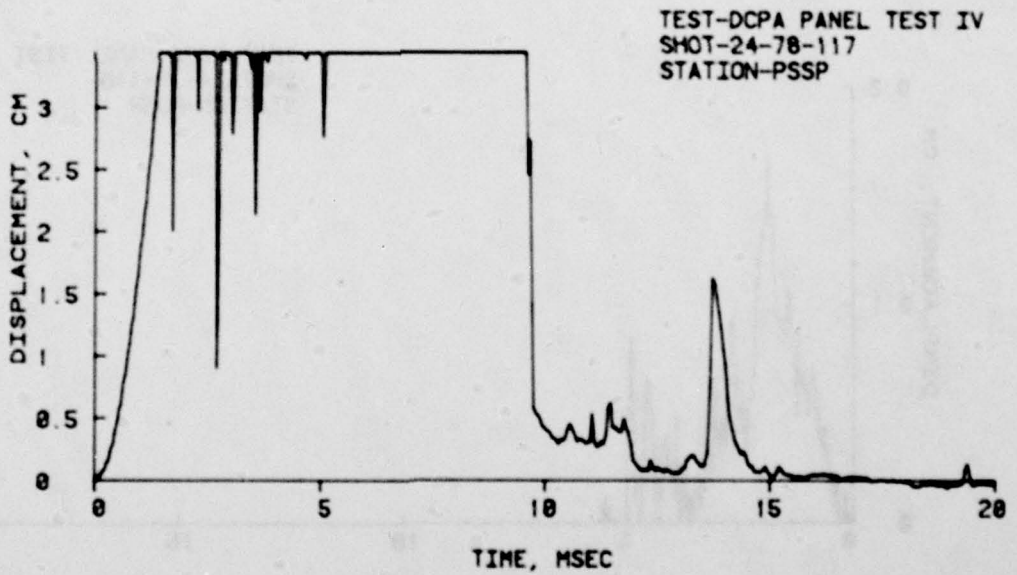
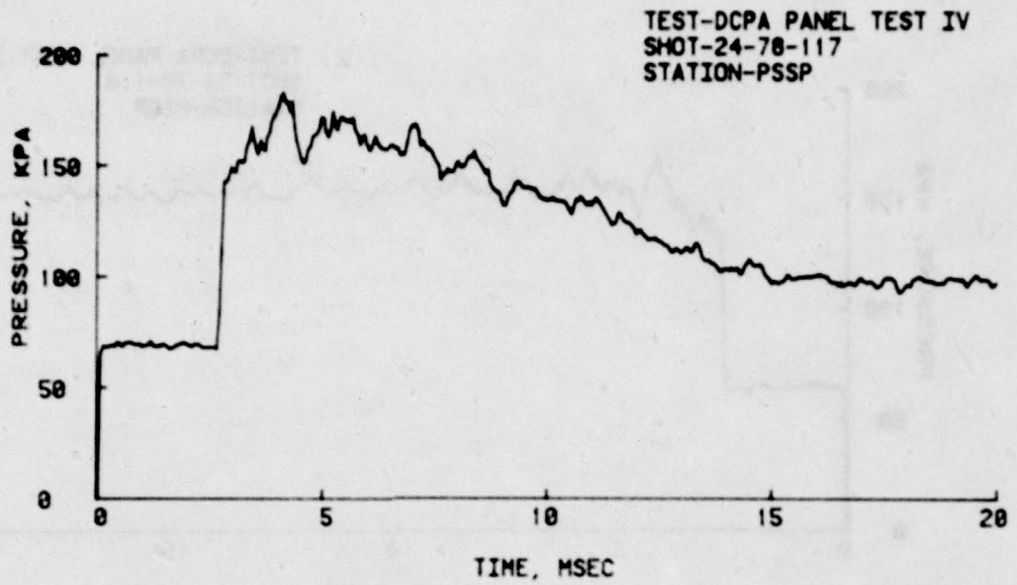

Figure A-7 (Cont). Records for PSSP closures with plywood skins glued.

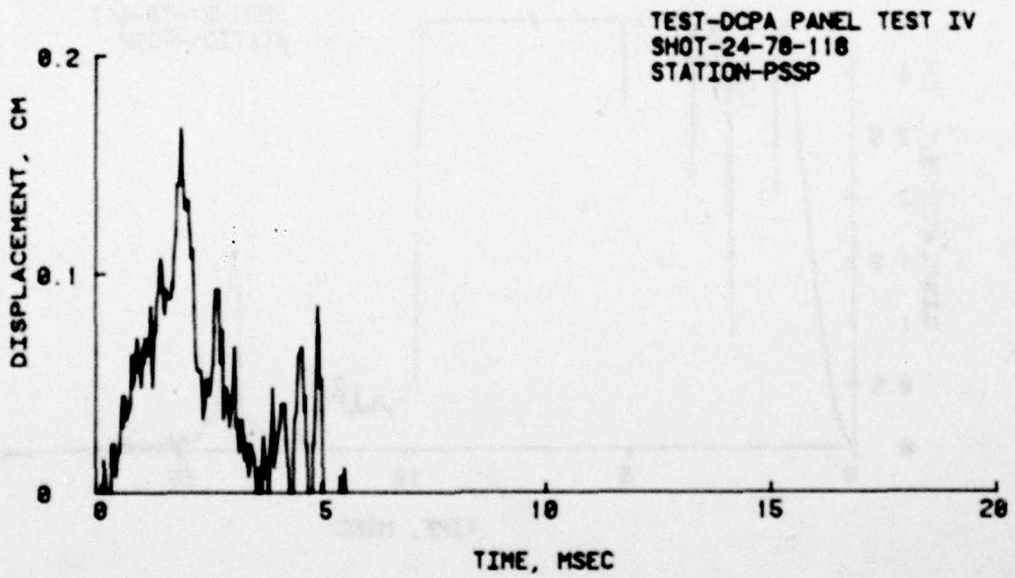
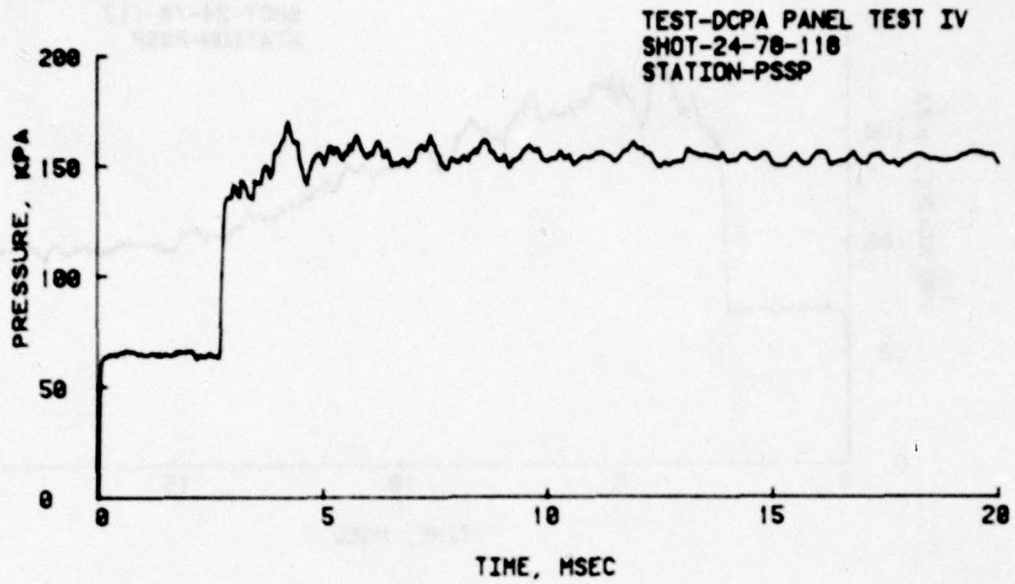

Figure A-7 (Cont). Records for PSSP closures with plywood skins glued.

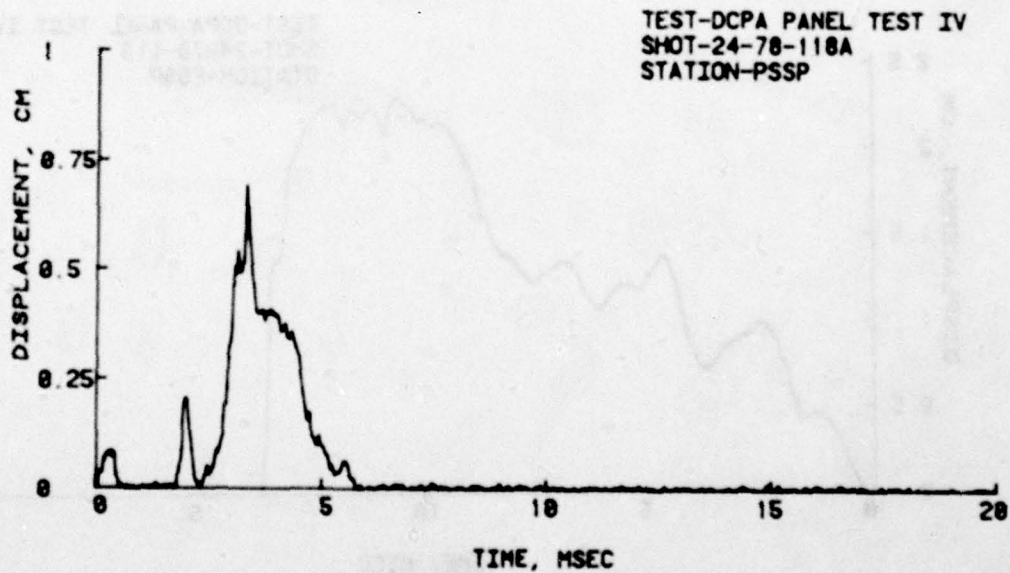
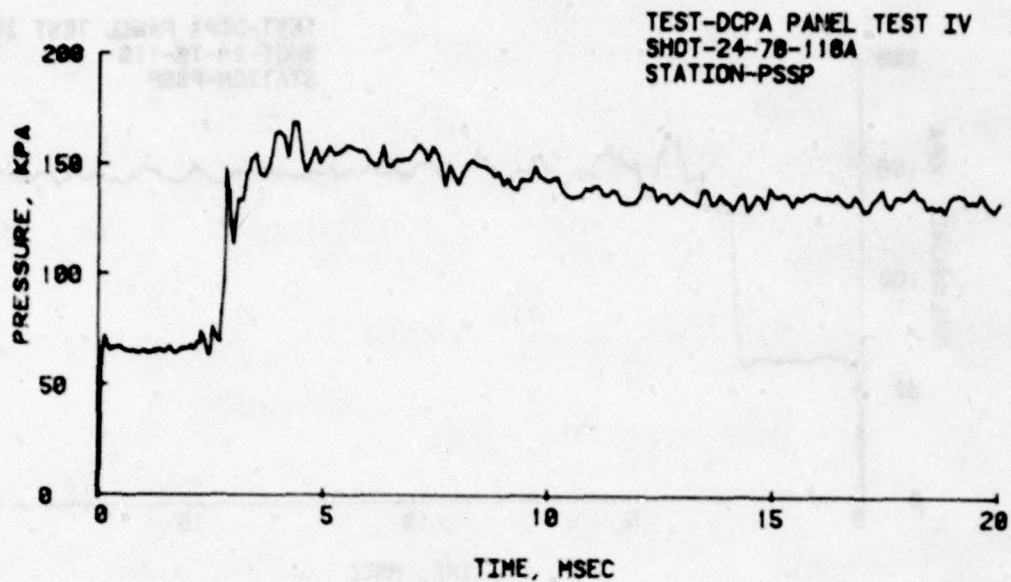

Figure A-7 (Cont). Records for PSSP closures with plywood skins glued.

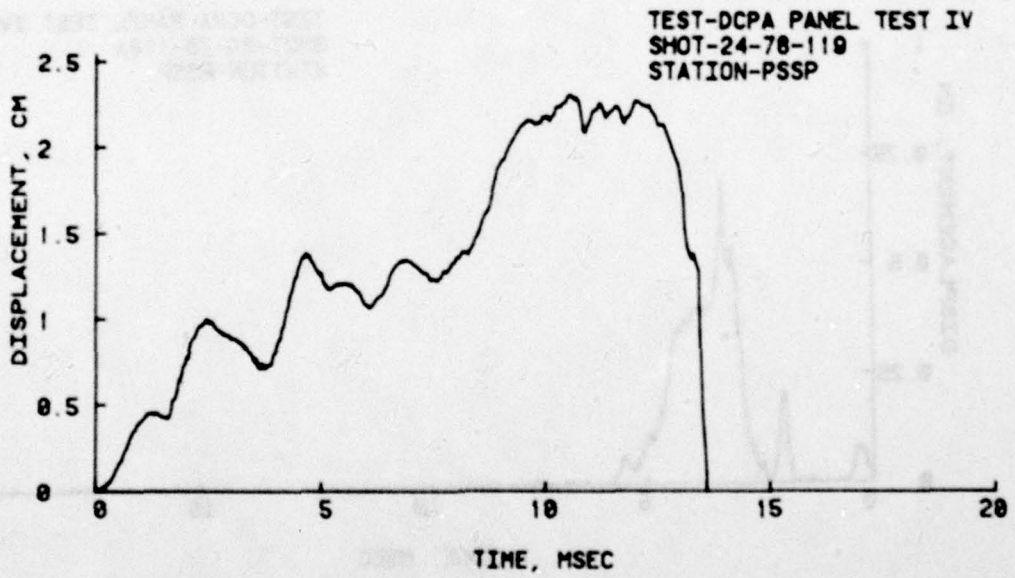
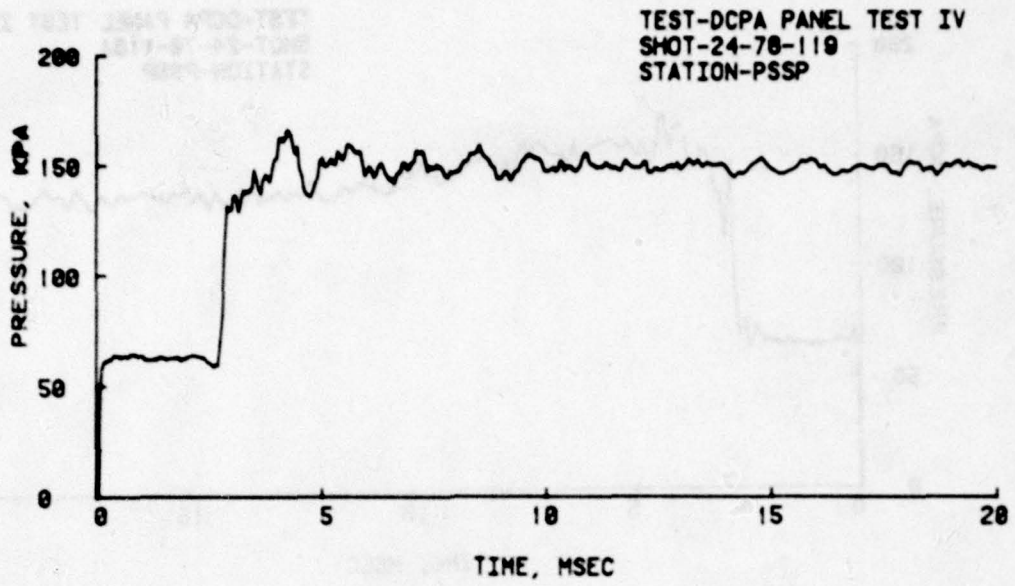

Figure A-7 (Cont). Records for PSSP closures with plywood skins glued.

LIST OF SYMBOLS

A	Cross section area, cm^2
b	Basic stringer spacing, cm
C, C'	Constants, no units
d	Thickness (depth) of beam, cm
E	Modulus of elasticity, kPa
EI	Flexural rigidity, $\text{kPa} \cdot \text{cm}^4/\text{width panel}$, cm
E_{st}^g	Modulus of elasticity of stringers, kPa
F_b	Allowable bending stress, kPa
F_c	Allowable bending stress - top skin, kPa
F_{cl}	Allowable bearing stress - load perpendicular to plane of outer ply or grain actually in bearing, kPa
F_s	Allowable rolling shear stress, kPa
F_v	Horizontal shear stress, kPa
f	Frequency, Hz
G	Modulus of rigidity, kPa
(Ib/Q)	Rolling shear constant, $\text{cm}^2/\text{cm width}$
l	Clear span, cm
l	Required end bearing length, cm
l^{ϕ}	Width of panel skin, cm
l''	Clear distance between stringers, cm
l''/C	Midspan deflection, cm
P_b	Allowable load - bending moment, kPa
P_d	Allowable load - panel deflection, kPa
P_m	Allowable load - corrected for ductility ratio, kPa
pps	Pictures per second
P_{st}	Allowable load - rolling shear stress, kPa
P_t	Allowable load - top skin deflection, kPa
P_v	Allowable load - horizontal shear, kPa
P_{qt}	Allowable load - top skin deflection, kPa
Q_v	Statical moment, cm^3
q_b	Flexural or bending resistance, kPa
S or KS	Effective section modulus, $\text{cm}^3/\text{cm width}$
t	Sum of stringer width, cm
μ	Ductility ratio, no units
W	Weight of panel, gm/cm^3
w	Width of panel, cm.
Yb	Bending deflection (elastic) under uniform load, cm
Ys	Shear deflection (elastic) under uniform load, cm

DISTRIBUTION LIST

<u>No. of Copies</u>	<u>Organization</u>	<u>No. of Copies</u>	<u>Organization</u>
12	Commander Defense Documentation Center ATTN: DDC-DDA Cameron Station Alexandria, VA 22314	1	Director US Army Air Mobility Research and Development Laboratory Ames Research Center Moffett Field, CA 94035
1	Defense Intelligence Agency ATTN: Mr. C. Wiehle Washington, DC 20301	1	Commander US Army Electronics Research and Development Command Technical Support Activity ATTN: DELSD-L Fort Monmouth, NJ 07703
2	Director Defense Nuclear Agency ATTN: SPSS (Mr. T. Kennedy) STAP (APTL, Library) Washington, DC 20305	1	Commander US Army Communications Rsch and Development Command ATTN: DRDCO-PPA-SA Fort Monmouth, NJ 07703
50	Defense Civil Preparedness Agency Research and Engineering ATTN: Admin Office Washington, DC 20301	2	Commander US Army Missile Research and Development Command ATTN: DRDMI-R DRDMI-YDL Redstone Arsenal, AL 35809
2	Defense Civil Preparedness Agency ATTN: RF(HV), Mr. Sisson PO(SE) Washington, DC 20310	1	Commander US Army Tank Automotive Research & Development Command ATTN: DRDTA-UL Warren, MI 48090
1	Commander US Army Materiel Development and Readiness Command ATTN: DRCDMD-ST 5001 Eisenhower Avenue Alexandria, VA 22333	1	Commander US Army Mobility Equipment Research & Development Cmd ATTN: DRDME-WC Fort Belvoir, VA 22060
1	Commander US Army Aviation Research and Development Command ATTN: DRSAV-E 12th and Spruce Streets St. Louis, MO 63166	1	Commander US Army Armament Materiel Readiness Command ATTN: DR SAR-LEP-L, Tech Lib Rock Island, IL 61299

DISTRIBUTION LIST

<u>No. of Copies</u>	<u>Organization</u>	<u>No. of Copies</u>	<u>Organization</u>
2	Commander US Army Armament Research and Development Command ATTN: DRDAR-TSS (2 cys) Dover, NJ 07801	1	Office of the Chief of Engineers ATTN: Mr. Tommasoni Department of the Army Washington, DC 20314
1	Commander US Army Harry Diamond Labs ATTN: DRXDO-TI 2800 Powder Mill Road Adelphi, MD 20783	1	Chief of Engineers ATTN: ENGME-RD Department of the Army Washington, DC 20314
1	Commander US Army Materials and Mechanics Research Center ATTN: DRXMR-ATL Watertown, MA 02172	2	Commander US Army Engineer Waterways Experiments Station ATTN: Docu Lib Nucl Wpns Eff Br P.O. Box 631 Vicksburg, MS 39180
1	Commander US Army Natick Research and Development Command ATTN: Dr. D. Sieling, DRXRE Natick, MA 01762	3	Commander Naval Air Systems Command ATTN: AIR-604 Washington, DC 20360
1	Director DARCOM Field Safety Activity ATTN: DRXOS-ES Charlestown, IN 47111	1	Commander Naval Facilities Eng Command ATTN: R&D Code 0322C Washington, DC 20390
1	Director US Army TRADOC Systems Analysis Activity ATTN: ATAA-SL, Tech Lib White Sands Missile Range NM 88002	3	Commander Naval Ordnance Systems Cmd ATTN: ORD-0632 ORD-035 ORD-5524 Washington, DC 20390
1	Deputy Assistant Secretary of the Army (R&D) ATTN: Asst for Rsch Washington, DC 20310	3	Commander Naval Supply Systems Command ATTN: Code 0652 Washington, DC 20390
1	HQDA (DAEN, ENGME-RD) Washington, DC 20310		

AD-A077 116

ARMY ARMAMENT RESEARCH AND DEVELOPMENT COMMAND ABERD--ETC F/G 13/3
BLAST LOADING OF CONSTRUCTION MATERIALS AND CLOSURE DESIGNS.(U)
AUG 79 G A COULTER
ARBRL-MR-02947

UNCLASSIFIED

SBIE-AD-E430 325

NL

2 OF 2
AD-A077116



END
DATE
FILMED

12-79
DDC

DISTRIBUTION LIST

<u>No. of Copies</u>	<u>Organization</u>	<u>No. of Copies</u>	<u>Organization</u>
1	Commander Naval Supply Systems Command ATTN: Code 0421G Department of the Navy Washington, DC 20390	2	Headquarters US Energy Research and Development Administration Department of Military Applications Div. of Biology & Medicine ATTN: Civil Eff BR Mr. L. J. Deal Dr. Rudolf J. Engelmann Washington, DC 20545
1	Chief of Naval Personnel ATTN: Code Pers M12 Department of the Navy Washington, DC 20360	1	Oak Ridge National Laboratory Civil Defense Research Project ATTN: Librarian P.O. Box X Oak Ridge, TN 37830
1	Chief of Naval Research Department of the Navy Washington, DC 20360	1	Office of Federal Building Tech Center for Building Technology ATTN: Mr. Samuel Karner, Ch National Bureau of Standards Washington, DC 20234
1	Commander Naval Civil Engineering Lab ATTN: Document Library Port Hueneme, CA 93401	1	National Bureau of Standards ATTN: Dr. Lewis V. Spencer RM C313-Building 245 Washington, DC 20234
1	AFWL (SUL) Kirtland AFB, NM 87117	1	Agbabian Associates 250 North Nash Street El Segundo, CA 90245
1	AFWL (Civil Eng Div) Kirtland AFB, NM 87117	3	Bell Telephone Laboratories ATTN: Mr. E. Witt Mr. R. Mayo Mr. J. Foss Whippany Road Whippany, NJ 07981
1	AFWL (Tech Library) Kirtland AFB, NM 87117	1	Center for Planning and Research, Inc. 2483 East Bayshore-Suite 104 Palo Alto, CA 94304
1	Civil Engineering Center AF/PRECET Tyndall AFB, FL 32401		
1	Civil Engineering Center AF/PRECE Wright-Patterson AFB, OH 45433		

DISTRIBUTION LIST

<u>No. of Copies</u>	<u>Organization</u>	<u>No. of Copies</u>	<u>Organization</u>
1	The Dikewood Corporation University Research Park 1009 Bradbury Drive, SE Albuquerque, NM 87106	1	R&D Associates ATTN: Dr. Henry Cooper 1401 Wilson Blvd. Rosslyn, VA 22209
1	Eberle Smith Associates, Inc. ATTN: Mr. Lyndon Welch 950 West Fort Street Detroit, MI 48226	2	Sandia Laboratories ATTN: Dir 5412, L. Vortman Dept 5230, Dr. Mehl Albuquerque, NM 87115
1	General American Transporta- tion Corporation General American Research Div 7449 North Natchez Avenue Niles, IL 60648	1	Scientific Services, Inc. ATTN: Mr. Charles Wilton 1536 Maple St Redwood City, CA 94063
1	Higgins, Auld & Associates Engineers ATTN: Cornelius J. Higgins 2601 Wyoming Blvd., Suite H-1 Albuquerque, NM 87112	3	SRI International ATTN: Dr. S. Martin Dr. H. Murphy J. Remple 333 Ravenswood Avenue Menlo Park, CA 94025
1	Management Science Associates P.O. Box 239 ATTN: Kenneth Kaplan Los Altos, CA 94022	1	Wiss, Janney, Elstner & Assoc. ATTN: Mr. J. R. Janney 330 Pfinsten Road Northbrook, IL 60062
1	Oklahoma Medical Resch Foundation ATTN: Dr. S. White Oklahoma City, OK 73104	1	George Washington University School of Engineering and Applied Science Nuclear Defense Design Center ATTN: Prof. R. Fox Washington, DC 20006
1	Pacific-Sierra Research Corp. ATTN: Harold L. Brode 1456 Cloverfield Blvd., Santa Monica, CA 90904	2	IIT Research Institute ATTN: Mr. A. Longinow Mr. T. Waterman 10 West 35th Street Chicago, IL 60616
2	The Rand Corporation ATTN: Dr. H. Brode Document Library 1700 Main Street Santa Monica, CA 90401	1	Pennsylvania State University ATTN: Prof. R. Kummer 101 Eng A University Park, PA 16802

DISTRIBUTION LIST

<u>No. of Copies</u>	<u>Organization</u>	<u>No. of Copies</u>	<u>Organization</u>
1	Purdue University Purdue Research Foundation School of Civil Engineering ATTN: Mr. M. Scott Civil Engineering Building Lafayette, IN 47907	1	University of Massachusetts School of Engineering ATTN: Dr. M. P. White Amherst, MA 01002
1	Director Program for Energy Research, Education & Public Service ATTN: Prof. Robert Bailey Oxley Hall, 1712 Neil Avenue Columbus, OH 43210	1	University of Washington Dept of Civil Engineering ATTN: Prof. W. Miller 307 More Hall Seattle, WA 98105
2	Research Triangle Institute ATTN: Edward L. Hill Milton D. Wright P.O. Box 12194 Research Triangle Park NC 27709		<u>Aberdeen Proving Ground</u> Dir, AMSAA ATTN: DRXSY, Dr. Sperrazza DRXSY-MP, H. Cohen Cdr, USATECOM ATTN: DRSTE-TO-F Dir, Wpns Sys Concepts Team, Bldg. E3516, EA ATTN: DRDAR-ACW
1	San Jose State College Dept of Civil Engineering ATTN: Dr. R. Spicker San Jose, CA 95114		
1	Worcester Polytechnic Inst Dept of Civil Engineering ATTN: Prof. C. Koontz Worcester, MA 01609		
1	University of Colorado School of Architecture ATTN: Prof. G. Vetter Boulder, CO 80302		
1	University of Florida Dept of Mechanical Engineering ATTN: Prof. J. Samuel Gainesville, FL 32601		
1	University of Illinois ATTN: Dr. W. Hall 111 Talbot Laboratory Urbana, IL 61803		

USER EVALUATION OF REPORT

Please take a few minutes to answer the questions below; tear out this sheet and return it to Director, US Army Ballistic Research Laboratory, ARRADCOM, ATTN: DRDAR-TSB, Aberdeen Proving Ground, Maryland 21005. Your comments will provide us with information for improving future reports.

1. BRL Report Number _____

2. Does this report satisfy a need? (Comment on purpose, related project, or other area of interest for which report will be used.)

3. How, specifically, is the report being used? (Information source, design data or procedure, management procedure, source of ideas, etc.) _____

4. Has the information in this report led to any quantitative savings as far as man-hours/contract dollars saved, operating costs avoided, efficiencies achieved, etc.? If so, please elaborate.

5. General Comments (Indicate what you think should be changed to make this report and future reports of this type more responsive to your needs, more usable, improve readability, etc.) _____

6. If you would like to be contacted by the personnel who prepared this report to raise specific questions or discuss the topic, please fill in the following information.

Name: _____

Telephone Number: _____

Organization Address: _____

