

AD-A077 161

SALFORD UNIV (ENGLAND) DEPT OF AERONAUTICAL AND MECH--ETC F/6 9/2
STUDY TOUR OF INDUSTRIAL ROBOTS IN JAPAN.(U)
AUG 79 T R CROSSLEY

UNCLASSIFIED

EOARD-TR-80-3

NL

| OF |
AD
A077161



END
DATE
FILMED
12-79
DDC

LEVEL

2

50



AD A 077161

DDC
RECEIVED
NOV 23 1979
E

STUDY TOUR OF
INDUSTRIAL ROBOTS IN JAPAN

T R CROSSLEY
UNIVERSITY OF SALFORD

DDC FILE COPY

This document has been approved
for public release and sale; its
distribution is unlimited.

19 REPORT DOCUMENTATION PAGE		READ INSTRUCTIONS BEFORE COMPLETING FORM	
1. Report Number 18 EOARD-TR-80-3	2. Govt Accession No.	3. Recipient's Catalog Number 9 Technical report	
4. Title (and Subtitle) 6 STUDY TOUR OF INDUSTRIAL ROBOTS IN JAPAN.		5. Type of Report & Period Covered 27 May - 10 June 1979	
7. Author(s) 10 T. R. Crossley, BSc(Eng), PhD, CEng, MRAS		6. Performing Org. Report Number	
9. Performing Organization Name and Address Department of Aeronautical and Mechanical Engineering University of Salford Salford M5 4WT, England		8. Contract or Grant Number	
11. Controlling Office Name and Address EOARD/LNI, Box 14 FPO New York 09510		10. Program Element, Project, Task Area & Work Unit Numbers 12 78	
14. Monitoring Agency Name and Address		12. Report Date 11 August 1979	
16. & 17. Distribution Statement Approved for public release; distribution unlimited.		13. Number of Pages 76	
18. Supplementary Notes			
19. Key Word: ROBOTS, MANIPULATORS, MANUFACTURING TECHNOLOGY, AUTOMATIC ASSEMBLY, SMALL-BATCH PRODUCTION			
20. Abstract This report describes a visit made to Japan between 27 May and 10 June 1979 to study the implementation and emerging developments of industrial robots in Japanese manufacturing industry. Visits to fourteen organizations are described of which some seven were engaged in the design and manufacture of robots as well as in their application. The majority of robots seen were engaged in spot-welding and arc-welding applications, although it was evident that they are being used in increasing numbers in the batch-manufacturing industries. A large number of pick-and-place mechanisms were seen, and these appear to be classified as robots when statistics are presented in Japan. No intelligent robots were seen, and very few programmable NC robot controllers were in evidence. <i>numerically controlled</i>			

13 November 1979

This report has been reviewed by the Information Office (EOARD/CMI) and is releasable to the National Technical Information Service (NTIS). At NTIS it will be releasable to the general public, including foreign nations.

This technical report has been reviewed and is approved for publication.

John T. Milton
JOHN T. MILTON
Scientific and Technical Information Officer

James R. Kreer
JAMES R. KREER, Major, USAF
Chief, Information Science

FOR THE COMMANDER

Gordon L. Hermann
GORDON L. HERMANN, LtColonel, USAF
Executive Officer

Accession For	
NTIS GRA&I	<input checked="" type="checkbox"/>
DDC TAB	<input type="checkbox"/>
Unannounced	<input type="checkbox"/>
Justification	<input type="checkbox"/>
By _____	
Distribution/	
Availability Codes	
Dist	Avail and/or special
A	.

STUDY TOUR OF
INDUSTRIAL ROBOTS IN JAPAN

T R CROSSLEY, BSc(Eng), PhD, CEng, MRAS
Reader
Department of Aeronautical and Mechanical Engineering
University of Salford
SALFORD M5 4WT
England

TRC/BAB

August 1979

ACKNOWLEDGEMENT

The author wishes to acknowledge the honorarium granted to him by the United States Air Force through the European Office of Aerospace Research and Development in London. Without this assistance, it would not have been possible to undertake this study tour.

CONTENTS

	page
ABSTRACT	iv
1 INTRODUCTION	1
2 THE JAPANESE INDUSTRIAL ROBOT ASSOCIATION, JIRA	2
2.1 <u>GENERAL</u>	
2.2 <u>DEFINITION AND CLASSIFICATION OF INDUSTRIAL ROBOTS IN JAPAN</u>	
2.3 <u>THE JIRA VIEW OF THE ADVANTAGES OF ROBOTS</u>	
3 TECHNICAL VISITS	
3.1 <u>FUJITSU FANUC LTD</u>	5
3.1.1 Profile	
3.1.2 Report	
3.1.3 Robot manufacture	
3.2 <u>NISSAN MOTOR CO. LTD.</u>	14
3.2.1 Profile	
3.2.2 Report	
3.3 <u>KAWASAKI HEAVY INDUSTRIES LTD</u>	16
3.3.1 Profile	
3.3.2 Report	
3.3.3 Robot manufacture	
3.4 <u>KOBE STEEL LTD.</u>	24
3.4.1 Profile	
3.4.2 Report	
3.4.3 Robot manufacture	
3.5 <u>SHIN MEIWA INDUSTRY CO. LTD.</u>	28
3.5.1 Profile	
3.5.2 Report	
3.5.3 Robot manufacture	
3.6 <u>MITUBISHI ELECTRIC CORPORATION</u>	32
3.6.1 Profile	
3.6.2 Report	
3.7 <u>TOYOTA MOTOR CO. LTD.</u>	34
3.7.1 Profile	
3.7.2 Report	
3.8 <u>NIPPONDENSO CO. LTD.</u>	35
3.8.1 Profile	
3.8.2 Report	
3.9 <u>MITSUBISHI MOTORS CORPORATION</u>	37
3.9.1 Profile	
3.9.2 Report	
3.10 <u>FUJI ELECTRIC CO. LTD.</u>	39
3.10.1 Profile	
3.10.2 Report	
3.10.3 Robot manufacture	

	page
3.11 <u>DAINI SEIKOSHA CO. LTD.</u>	46
3.11.1 Profile	
3.11.2 Report	
3.11.3 Robot manufacture	
3.12 <u>NAGASAKIYA TOKYO DISTRIBUTION CENTRE</u>	50
3.12.1 Profile	
3.12.2 Report	
3.13 <u>TOSHIBA SEIKI CO. LTD.</u>	52
3.13.1 Profile	
3.13.2 Report	
3.13.3 Robot manufacture	
3.14 <u>JAPAN MARINE SCIENCE AND TECHNOLOGY CENTRE</u>	59
3.14.1 Profile	
3.14.2 Report	
4 CONCLUSIONS	60
APPENDIX 1: JIRA Membership List	
APPENDIX 2: Addresses of Companies visited	

LIST OF FIGURES

FUJITSU-FANUC LTD.

- Fig. 3.1.1 FANUC ROBOT-MODEL 1
- Fig. 3.1.2 FANUC ROBOT HANDS AND WRISTS
- Fig. 3.1.3 FANUC ROBOT-MODEL 2
- Fig. 3.1.4 FANUC NC MACHINE-TOOL SYSTEMS

KAWASAKI HEAVY INDUSTRIES LTD.

- Fig. 3.3.1 KAWASAKI-UNIMATE SERIES 20 ROBOT MAIN BODY
- Fig. 3.3.2 KAWASAKI-UNIMATE SERIES 26 ROBOT MAIN BODY
- Fig. 3.3.3 KAWASAKI-UNIMATE SERIES 30 ROBOT MAIN BODY
- Fig. 3.3.4 KAWASAKI-UNIMATE SERIES 46 ROBOT MAIN BODY
- Fig. 3.3.5 KAWASAKI-UNIMATE SERIES 50 ROBOT MAIN BODY
- Fig. 3.3.6 KAWASAKI-UNIMATE MODEL 3330
- Fig. 3.3.7 KAWASAKI-UNIMATE MODEL 6060

KOBE STEEL LTD.

- Fig. 3.4.1 KOBE-TRALLFA SPRAY-GUN MANIPULATOR
- Fig. 3.4.2 KOBE ARCMAN ARC-WELDING ROBOT

SHIN MEIWA INDUSTRY CO. LTD.

- Fig. 3.5.1 SHIN MEIWA ROBOT WELDER PW150 SERIES
- Fig. 3.5.2 SHIN MEIWA ROBOT WELDER PW751

FUJI ELECTRIC CO. LTD.

- Fig. 3.10.1 FUJI VARI-O-MATIC F1 PRESS HAND
- Fig. 3.10.2 FUJI MOTORISED HAND
- Fig. 3.10.3 FUJI ROBOT SYSTEM CONFIGURATIONS
- Fig. 3.10.4 FUJI DIGITAL AUTOMATED SHEARING LINE

DAINI SEIKOSHA CO. LTD.

- Fig. 3.11.1 DAINI SEIKOSHA MODEL 100
- Fig. 3.11.2 DAINI SEIKOSHA MODEL 200
- Fig. 3.11.3 DAINI SEIKOSHA MODEL 400
- Fig. 3.11.4 DAINI SEIKOSHA MODEL 700

TOSHIBA SEIKI CO. LTD.

- Fig. 3.13.1 TOSMAN 200 ROBOT
- Fig. 3.13.2 TOSMAN IX-15 ROBOT
- Fig. 3.13.3 TOSMAN IX-12 ROBOT
- Fig. 3.13.4 TOSMAN RHP TRANSER ROBOT
- Fig. 3.13.5 TOSMAN RBM TRANSER ROBOT

ABSTRACT

A STUDY TOUR OF INDUSTRIAL ROBOTS IN JAPAN

T. R. CROSSLEY

This report describes a visit made to Japan between 27 May and 10 June 1979 to study the implementation and emerging developments of industrial robots in Japanese manufacturing industry. Visits to fourteen organizations are described and, of these, some seven were engaged in the design and manufacture of robots as well as in their application. The majority of robots seen were engaged in spot-welding and arc-welding applications, although it was evident that they are being used in increasing numbers in the batch-manufacturing industries. A large number of pick-and-place mechanisms were seen, and these appear to be classified as robots when statistics are presented in Japan. No intelligent robots were seen, and very few programmable NC robot controllers were in evidence.

PRECEDING PAGE BLANK

1. INTRODUCTION

This report describes the study tour made by the author between 27 May 1979 and 10 June 1979 to a representative number of companies in Japan, the majority of which were using industrial robots in their manufacturing operations. The tour was organized by the British Robot Association of 35-39 High Street, Kempston, Bedford, England in conjunction with both the Japanese Industrial Robot Association and the Japanese Tourist Board.

Only companies in the industrial belt on the main island on the south-east seaboard of Japan were visited, and short stays were made in Tokyo, Kobe, Kyoto, and Nagoya. It was possible only to visit such a large number of companies in the limited time available because of the excellent internal travelling arrangements organized by the Japanese Tourist Board (JTB) using both Japanese National Railways and private hire coaches, as appropriate: the day-by-day administration of the tour was conducted by an official of the JTB who also acted as a technical interpreter when required.

The format for each visit was almost always the same. It consisted of a formal introduction to the technical managers and engineers, generally followed by the distribution of brochures and exchange of visiting cards and gifts. Usually, a film was shown before a conducted tour of the relevant areas of interest in the plant. After the tour, about half an hour was devoted to a question-and-answer session: the duration of each visit varied from two to three hours. Photography was not allowed in any of the factories, and this report can only be illustrated by selected extracts from photocopies of the company brochures.

The report is written with three main sections and two appendices. Section 2 is devoted to the Japanese Industrial Robot Association (JIRA), and much of the information presented is based on JIRA literature. Fourteen visits were made in all, and all of these are described in Sections 3.1. to 3.14, respectively. Each of these sections is divided further into two or three sub-sections entitled Profile, Report and Robot Manufacture. The conclusions and overall impressions are presented in Section 4. For completeness, the JIRA membership list is given in Appendix 1, and the addresses of the companies visited and the principal contacts are listed in Appendix 2.

2.0 THE JAPANESE INDUSTRIAL ROBOT ASSOCIATION

2.1 GENERAL

The development of industrial robots in Japan was commenced in the late 1960s, and rapid progress was achieved which enabled them to be put into practical use in the first half of the 1970s. It is expected by the Japanese Industrial Robot Association, JIRA, (which was established in 1971) that robots will be put into wider use in the future and that their full-scale dissemination throughout Japan will take place in the 1980s. About 30 thousand industrial robots were in operation in Japan at the end of 1977, and it is expected that by 1985 the annual production of industrial robots will be fifteen times that achieved in 1977.

JIRA is engaged in a wide variety of activities including public relations, promotion of technological development, and the further application of industrial robots. In addition, JIRA is making efforts to step up the international exchange of technology by organising international symposia and exhibitions of industrial robots. The JIRA now has a membership composed of 39 regular corporate members (see Appendix 1), 49 supporting corporate members, and 282 individual members.

2.2 DEFINITION AND CLASSIFICATION OF INDUSTRIAL ROBOTS IN JAPAN

In Japan, industrial robots are commonly defined as manipulators which have a high degree of freedom and which perform versatile movement functions. Table 2.1 shows the classification of industrial robots and their respective definitions as approved by the Terminology Standardisation committee of JIRA in 1974.

2.3 THE JIRA VIEW OF THE ADVANTAGES OF ROBOTS

- (i) Industrial robots enable improved productivity, particularly as an effective means of automating small batch production which could not be achieved by existing special-purpose automatic machinery and equipment. This advantage can only be obtained from highly-flexible working functions characteristic of industrial robots. That industrial robots have such functions is clearly indicated by the fact that they are able to easily meet changes in specific work required with the lapse of time - for instance, their operation programs can be easily modified to cope with model change-over (time

TABLE 2.1 Classification of Industrial Robots

Name	Definition
(1) manual manipulator	manipulator which is directly operated by a man.
(2) sequence robot	manipulator, the working step of which operates sequentially in compliance with preset procedures, conditions and positions.
(2)-1 fixed sequence	sequence robot as defined above, the preset information of which cannot be changed easily.
(2)-2 variable sequence	sequence robot as defined above, the preset information of which can be changed easily.
(3) playback robot	a robot which is taught first a certain working procedure through operating it, so that the robot itself memorises the procedure, then it can continuously repeat its operation.
(4) N.C. robot	manipulator which can execute the commanded operation in compliance with numerically-controlled information such as positions, sequences or conditions.
(5) intelligent robot	a robot that performs various functions itself through sensing and recognising capabilities.

flexibility), and the spatial modification of their working and movement path can be easily made (space elasticity).

- (ii) In the case of mass production, where product redesigning requires an enormous amount of time and money for remodelling, industrial robots can save such time and money.
- (iii) Industrial robots can be diverted to other applications or be transferred to different plants.
- (iv) Industrial robots are capable of 24-hour operation and thereby greatly enhance the efficiency of expensive plant and equipment.
- (v) Industrial robots enable substantial changes to be made in production volumes.
- (vi) Unlike human beings, industrial robots are free from fatigue of simple duties performed over long hours and reduce the number of defective quality products caused by such fatigue.

- (vii) Industrial robots can increase the service life of tools such as welding devices and can economise on the use of materials (for example, paints by precisely repeating the given motions).
- (viii) Industrial robots help prevent industrial accidents and occupational diseases often caused by working in dangerous environments and under unfavourable conditions. This is one of the greatest socio-economic advantages to be gained.
- (ix) Industrial robots help reduce economic losses caused by workers leaving their jobs due to working under unfavourable conditions.

3 TECHNICAL VISITS

3.1 FUJITSU FANUC LTD.

3.1.1 Profile

Fujitsu Fanuc Ltd. was founded in 1972 when it became independent from the parent company, Fujitsu Ltd., which had been developing numerically-controlled systems (NC) since 1956. During the period 1956 - 1970, Fujitsu had developed the first point-to-point NC in Japan, the first continuous-path NC in Japan, a fully modularized NC, and the first commercialized DNC in the world. After 1972, Fujitsu Fanuc developed a new range of NC systems and began the design and manufacture of both NC machine tools, industrial robots and NC programming systems. The number of employees is approximately 780, and the paid-in capital was 2 billion yen in 1978.

Monthly sales turnover is 4 billion yen, using a work force with an average age of 30 years. Approximately, 200 of the employees are engaged in active research and development which is all funded using Company monies (5% to 6% of sales)

3.1.2 Report

The visit was to the Hino-shi headquarters of Fujitsu Fanuc near Tokyo. At this site, more than 1000 CNC units are produced each month together with a range of machine tools and industrial robots (see section 3.1.3). Fanuc NC systems have an 80% share of the Japanese market and some 40% of production is exported. The factory has many in-house automated machine-tool systems consisting of linked CNC tools and Fanuc robots. In all, there are 15 robots in actual use, and it is planned to have a further 20 by the end of 1979. Although the robots are used by the workers as an aid at the moment, it is the intention of the management to introduce an unmanned 16-hour night shift for the production of large batches of components: the manned day shift will then be used for the manufacture of small batch items only.

A number of robot-assisted CNC and DNC cells were in operation during the visit and these included:

- . DNC cell comprising 2 Robot-Model 1s, (each working with 1 NC machine-tool) and 2 Robot-Model 2s (each working with 3 CNC machine-tools).

- . a cell comprising a Robot-Model 2 working with a Fanuc Tape Centre C lathe, a Fanuc mini-machining centre, and a chucking lathe with a tool changer.
- . a cell comprising a Robot-Model 2 working with a Hitachi drill/mill and an Okamoto grinding machine.
- . a cell comprising a Robot-Model 1 working with a DynaTurn 3L lathe.
- . a DNC cell comprising a Kawasaki-Unimate robot working with two Fanuc 20A NC lathes (this was the original Fanuc DNC system, and had clearly been in active operation for many years).

For completeness, this section concludes with a list of relevant Fanuc NC systems and machine tools which were seen during the tour. The NC systems included the System 5 series, the System 7 series, the Mate series, and the Ulti-mate series; whilst the machine tools included the Tape Cut series, the Tape Centre series, the mini-machining centre series and the CNC mini-lathe series. In addition, a production line of the automatic NC programming system, Fanuc System P-Model D, was seen.

3.1.3 Robot manufacture

Fanuc Robot - Model 1

This is the smaller of the two currently-available Fanuc robots, and is suitable for the automatic loading and unloading of workpieces, tool changing, chip disposal for one or two machine tools, preferably of the CNC type. A variety of wrists and hands can be fitted. The basic geometric configuration is based on a cylindrical-coordinate axis set with five degrees of freedom (see Fig.3.1.1). Motion specifications are arm up-down (500mm at 500mm/sec), arm rotation ($\pm 105^\circ$ at $60^\circ/\text{sec}$), arm extension (800/1000mm at 1000mm/sec). Three wrists (A,B,C) can be fitted with rotation and bending (see Fig.3.1.2). Wrist A is fixed but can carry a load of 47 kg, wrist B has on/off control of rotation ($0^\circ, 90^\circ, 180^\circ$) and a fixed setting within $\pm 3.5^\circ$ in bending, whereas wrist C has continuous control of rotation (up to 180° at $60^\circ/\text{sec}$) and within $\pm 3.5^\circ$ in bending (on/off control). Wrists B and C are used mainly for the control of one or two machine tools, respectively. The three arm-motion drives are by DC motors, and only one axis can be controlled at the same time. Programming is by teach-in/ playback and up to 80 program steps can be stored in the control memory, although a magnetic tape cassette is available as an option.

Four basic hand units (T, M, TM, and D) are provided (see Fig. 3.1.2). Hand T has a flexible push mechanism, and eccentricity and declination can be absorbed: the hand is suitable for lathes and rotation is not provided. On hand M, revolution positioning around the centre of the workpiece is possible: the hand is suitable for milling machines and a flexible push mechanism is not provided. Hand TM has both flexible push and rotation mechanisms, and can be used for both lathes and milling machines. Only a flexible push mechanism is provided on Hand D but it is able to grip two workpieces at a time thus reducing waiting time at the machine tool.

The controller has functions to allow easy programming of two palletizing strategies. Firstly, there is a program for loading and unloading workpieces stacked on a semi-circular table around the robot. Secondly, there is a program to allow workpieces arranged on a lattice in the horizontal plane to be loaded and unloaded.

Fanuc Robot - Model 2

This robot is larger than the Fanuc Model 1, and is suitable for a similar class of work in a light-machine shop. However, because of the larger reach, it can service up to five CNC machines arranged in a circle centred on the vertical axis of the robot. The degrees-of-freedom are identical to those in the Model 1, although the vertical z-axis is mounted on a sturdy C-type frame (See Fig.3.1.3). Motion specifications are arm up-down (800mm at 500mm/sec) from a minimum height of 600mm, arm rotation (-140° to $+160^{\circ}$ at $60^{\circ}/\text{sec}$), arm extension (1100mm from a minimum radius of 1190mm at 500mm/sec). A standard wrist is fitted with rotation (-90° to $+180^{\circ}$ at $60^{\circ}/\text{sec}$) and bending (-90° to $+30^{\circ}$ at $60^{\circ}/\text{sec}$). Any one of the four hands used by the Model 1 can be attached to the wrist.

The three arm-motion drives are by DC motor, and all three axes can be controlled simultaneously. Programming and program storage are similar to those employed in the Model 1.

Fanuc NC machine-tool systems

The Fanuc Robot-Models 1 and 2 can be incorporated in a range of small cells comprising NC machines, robots, workpiece feeders and tool racks. Three typical systems of this class are shown in Fig. 3.1.4.

Fig.3.1.4(a) is an example of an "automated machine tool" consisting of one NC lathe and one Fanuc Robot-Model 1. The robot unloads a workpiece from the

workpiece table and loads it on the NC lathe. On completion of turning, the robot unloads the finished workpiece and stacks it on the workpiece table (palletizing). That is, materials on the workpiece table are automatically machined within a fixed time, and put on the workpiece table as finished workpieces.

Fig.3.1.4(b) is an example of an "automated machine tool" consisting of one NC milling machine and one Fanuc Robot-Model 1. First the robot picks up a specified tool from the tool rack and fits it in the spindle of the NC milling machine. The robot then picks up a workpiece from the workpiece table and loads it on the NC milling machine. If required, the robot changes the tool during milling operation. The robot unloads the finished workpiece from the NC milling machine and puts it on the workpiece table.

Fig.3.1.4(c) is an example of an "Automated Compact Machining System" consisting of two NC lathes, one NC milling machine and one Fanuc Robot-Model 2. On completion of the specified turning and milling operations, a workpiece on the workpiece table or work feeder is put back on it as a finished item.

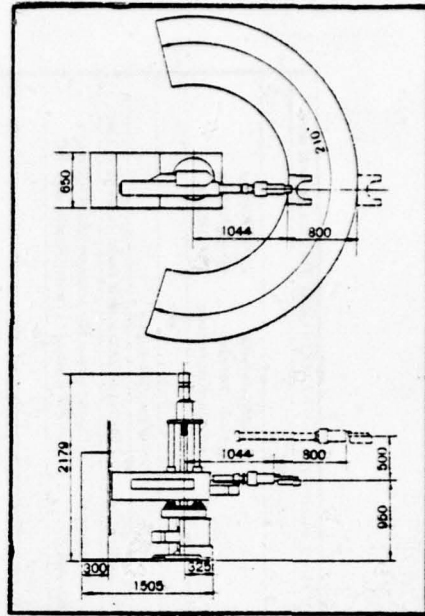
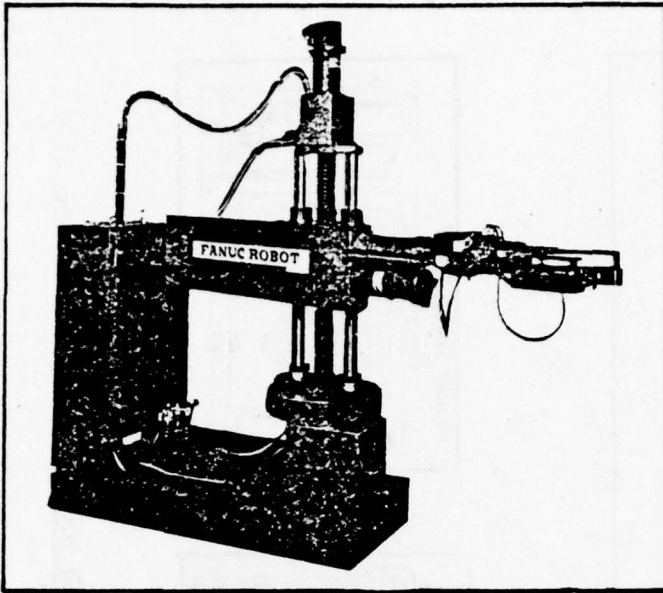

CNC machine tools to be controlled		1 set or 2 sets (Option)			
Arm	Motion range	Z axis: Up/down	950 ~ 1,450mm (500mm)		
		θ axis: Rotation	-105° ~ 105° (210°)		
	R axis: Out/in (option)	S	735 ~ 1,535mm (800mm) (With wrist A), 1,044 ~ 1,844mm (800mm) (With wrist B C)		
		L	751 ~ 1,851mm (1,100mm) (With wrist A), 1,060 ~ 2,160mm (1,100mm) (With wrist B C)		
Motion speed	Z axis: Up/down	300mm/sec			
	θ axis: Rotation	60°/sec			
	R axis: Out/in	1,000mm/sec			
Wrist	Type of wrist (option)		Wrist A	Wrist B	Wrist C
	Motion range	α axis: Rotation	Fixed	0° and 90° 0° and 180° (On/off control)	-90° ~ 180° (Continuous Control)
		β axis: Bending	Fixed	Within $\pm 3.5^\circ$ (fixed) (Mechanical Setting)	Within $\pm 3.5^\circ$ (On/off control)
	Motion speed	α axis: Rotation	—	60°/sec	60°/sec
		β axis: Bending	—	—	30°/sec
	Weight capacity of workpiece		47kg	31kg	31kg
Control		—	Air 5 ~ 7kg/cm ²	Air 5 ~ 7kg/cm ²	
Repeatability		± 1 mm			
Playback system		Memory with basic 80 points (Max. 251 points (Option))			
Auxiliary Memory (Option)		LSI Cassette			
Driving Method		Z, β R-axis: DC servo motors, 1-axis at a time			
Power Source		4KVA AC200 220 230V $\pm 1\%$; AC380 415V $\pm 1\%$; (Option) 50 60Hz 3 ϕ			
Weight		750kg			

FIG. 3.1.1 FANUC ROBOT-MODEL 1

Function	Application	FANUC HAND T (for turning)	FANUC HAND M (for Milling machine)	FANUC HAND TM (for general use)
Gripping method	Centripetal grip with 3 fingers			
Range of grip	Outer diameter 20-158mmφ, 82-220mmφ Inner diameter 38-176mmφ, 100-238mmφ Square workpiece 3-129mm, 56-180mm (Note 1) (Note 2)			Outer diameter 22-220mmφ Inner diameter 40-240mmφ Square workpiece 0-180mm
Weight of workpiece	Max 20kg			
Gripping speed	3 sec/full-stroke			4 sec/full-stroke
Flexible push mechanism	Eccentricity and backlash can be absorbed. Flexibly amount : 3mm	Not provided		Eccentricity and backlash can be absorbed. Flexibly amount : 3mm
Rotation mechanism	Not provided		Capable of revolution positioning control (revolving a workpiece around its center). Rotation angle 90°	Capable of revolution positioning control (revolving a workpiece around its center). Rotation angle 180°
Safety mechanism	Protection of the hand from excessive load by breaking down of the safety joint			
Power supply	Air pressure 5-7kg/cm ²			
Weight of hand	9kg	11kg		14kg

Note 1) Range of grip can be changed by inserting spacers between fingers and claws.
 Note 2) ① Maximum 17kg when FANUC HAND TM is used for MODEL 1.
 ② Maximum 5-7kg for workpieces with small gripping areas of 4-10mm.
 ③ Maximum rotation moment is limited if horizontal load is applied to the gripping area.
 ④ Maximum 15kg for rectangular workpieces gripped by two fingers.

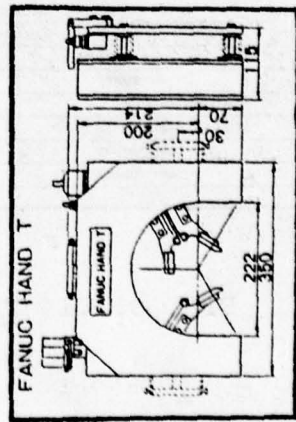
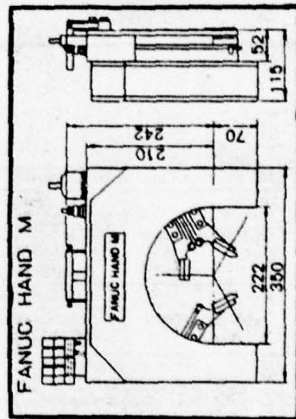
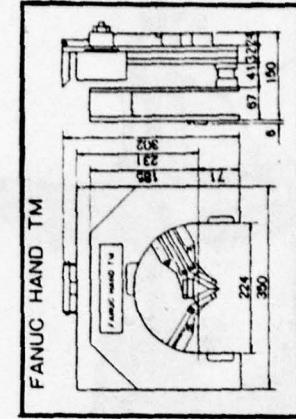
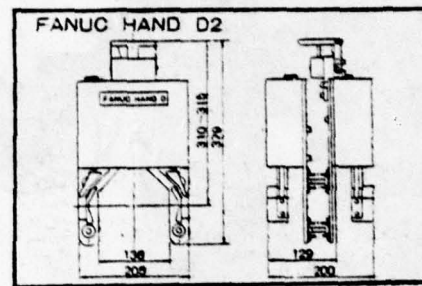
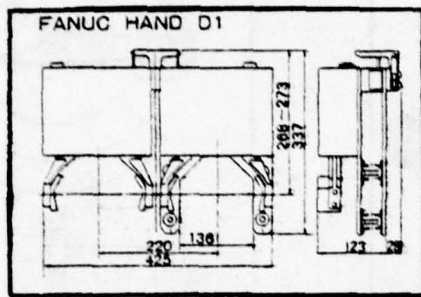

FIG. 3.1.2 FANUC ROBOT HANDS AND WRISTS

Function	Application	FANUC HAND D (Double hand)
Gripping method		Centripetal grip with 2 fingers (two grippers)
Range of grip		Outer diameter 20-150mm ϕ (Note 1)
Weight of workpiece		Max. 10kg for each gripper
Gripping speed		2 sec./full-stroke
Flexible push mechanism (option)		Eccentricity and declination can be absorbed. Flexibility amount ± 3 mm
Rotation mechanism		Not provided
Safety mechanism		Protection of the hand from excessive load by breaking down of the safety joint
Power supply		Air pressure 5-7kg/cm ²
Weight of hand		12kg

Note 1) Range of grip can be changed by inserting spacers between fingers and claws.
 Note 2) Two types of double hand are available, namely, the parallel combination type (D1 type) and the back combination type (D2 type).



Wrist A α axis: fixed
 β axis: fixed

Wrist A is used when the rotation (α axis) and bending (β axis) of the wrist are not necessary.

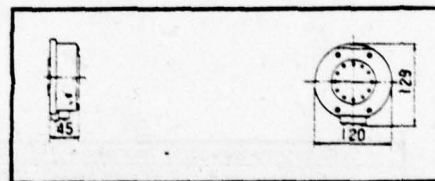

Wrist B α axis: 0°/90°, 180°
 β axis: within $\pm 3.5^\circ$

The rotation of the wrist (either 90° or 180°) is possible by on/off control. The bending of the wrist can be mechanically set within $\pm 3.5^\circ$. The wrist B is used mainly for the control of one machine tool.

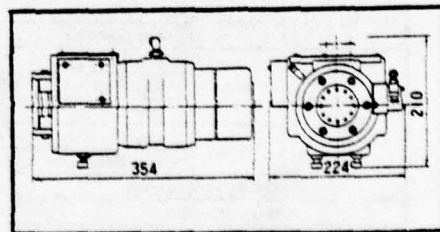

Wrist C α axis: -90°~180°
 β axis: within $\pm 3.5^\circ$

The rotation of the wrist can be controlled continuously. The bending of the wrist is possible within $\pm 3.5^\circ$ by on/off control. The wrist C is used mainly for the control of two machine tools.

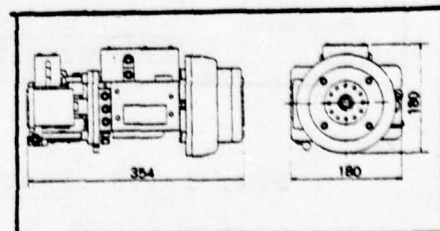
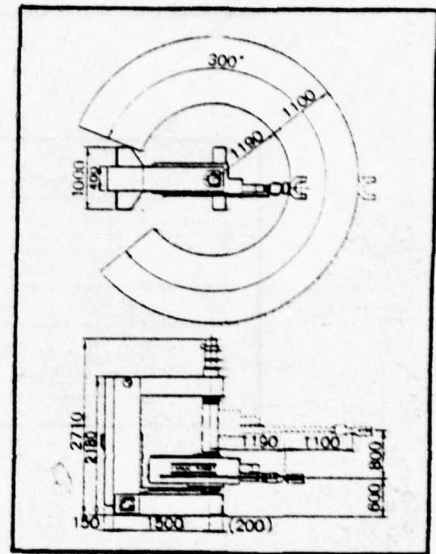
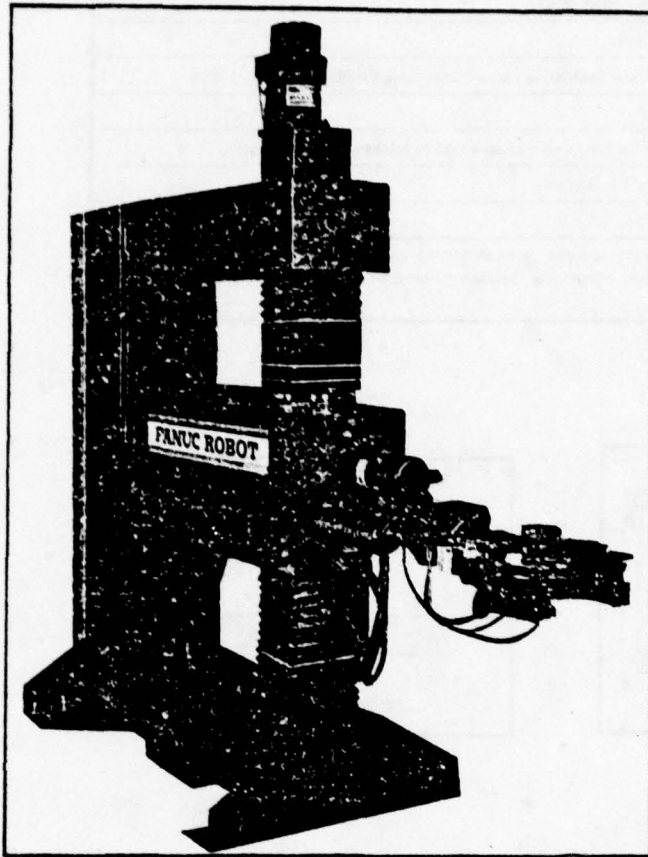

FIG. 3.1.2 (cont) FANUC ROBOT HANDS AND WRISTS



CNC machine tools to be controlled		5 Sets	
Motion range	Arm	Z axis: Up/down	600 ~ 1,400mm (800mm)
		θ axis: Rotation	-140 ~ 160° (300°)
		R axis: Out/in	1,190 ~ 2,290mm (1,100mm)
Motion speed (Max.)	Wrist	α axis: Rotation	-90 ~ 180° (270°)
		β axis: Bending	-90 ~ 30° (120°)
Motion speed (Max.)	Arm	Z axis: Up/down	500mm/sec
		θ axis: Rotation	60°/sec
		R axis: Out/in	500mm/sec
	Wrist	α axis: Rotation	60°/sec
β axis: Bending		60°/sec	
Positioning repeatability		± 1mm	
Playback system		Memory with basic 50 points (Max. 704 + α points (option))	
Auxiliary Memory		Provided (option)	
Driving method		DC servo motors, 3 axes at a time	
Power source	Input voltage	AC 200/220V ± 1% AC230/380/415V ± 1% (Option) 50/60Hz ± 1Hz, 3 ϕ	
	Power consumption	7kVA	
Weight		1,800kg	

FIG. 3.1.3 FANUC ROBOT-MODEL 2

(a)

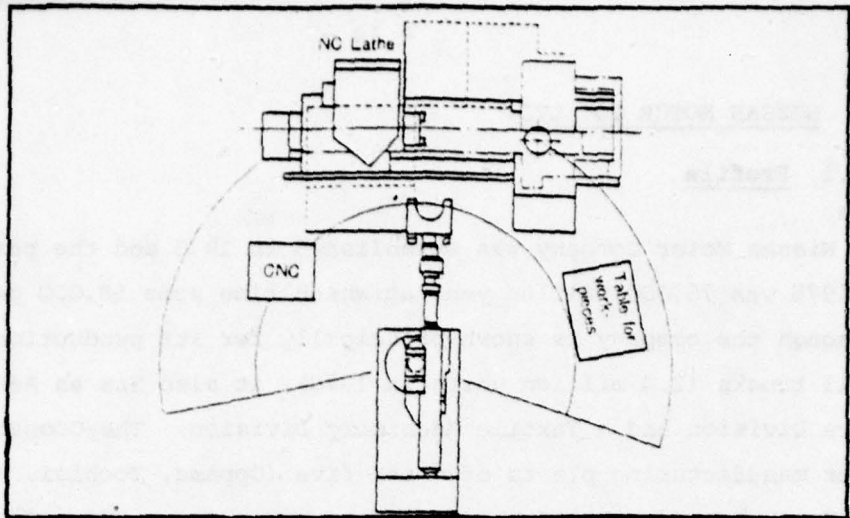

(b)

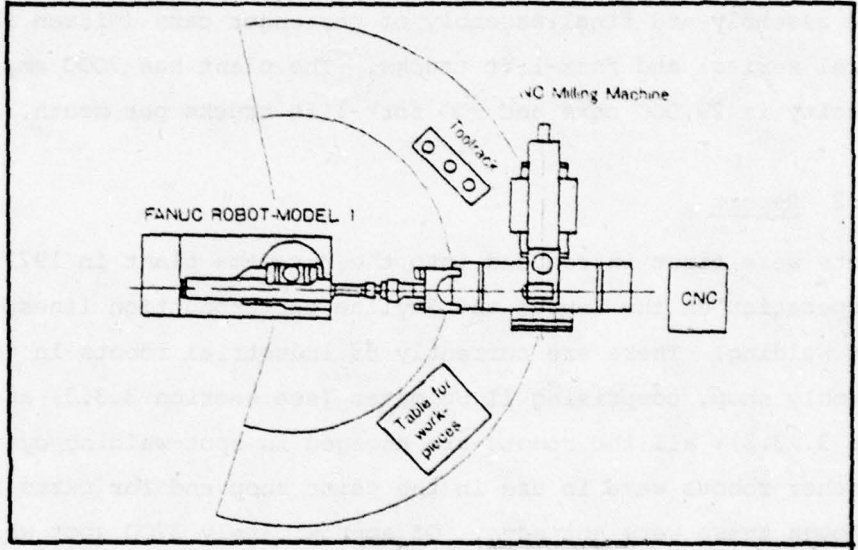

(c)

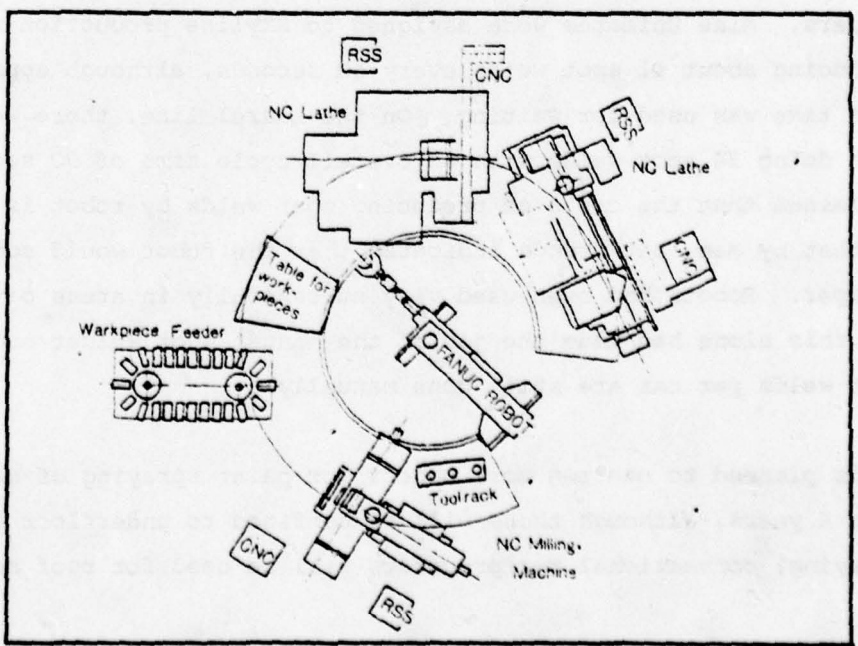

FIG. 3.1.4 FANUC NC MACHINE-TOOL SYSTEMS

3.2 NISSAN MOTOR CO. LTD.

3.2.1 Profile

The Nissan Motor Company was established in 1933 and the paid-in capital in 1978 was 76,000 million yen, at which time some 58,000 people were employed. Although the company is known principally for its production of cars and small trucks (2.4 million units in 1978), it also has an Aeronautical and Space Division and a Textile Machinery Division. The Company has nine major manufacturing plants of which five (Oppama, Tochigi, Zama, Murayama, and Kyushu) produce automobiles and trucks. The study tour visit was to the Murayama plant located in Musashi-Murayama city in north-west Tokyo. It is a modern integrated manufacturing complex engaged in machining various parts, axle assembly and final assembly of passenger cars (Nissan Skyline and Laurel series) and fork-lift trucks. The plant has 7000 employees and the capacity is 29,000 cars and 900 fork-lift trucks per month.

3.2.2 Report

Robots were first introduced into the Murayama plant in 1973 and are currently in operation on the Laurel and Skyline car production lines, principally for spot welding. There are currently 85 industrial robots in the car-body assembly shop, comprising 11 Unimates (see section 3.3.3) and 74 Tosman 200s (see 3.13.3): all the robots are engaged in spot-welding operations. A number of other robots were in use in the paint shop and for parts transfer operations, although these were not seen. Of approximately 2700 spot welds on each Skyline car, some 1700 were done using automation. Of these 1700, 100 were done using Unimates, 300 using Tasman 200s, and the remaining 1300 by multi-welders. Nine Unimates were assigned to Skyline production with each robot producing about 11 spot welds every 50 seconds, although approximately half this time was used for waiting. On the Laurel line, there were 2 Unimates each doing 34 spot welds with an overall cycle time of 90 seconds. It was explained that the costs of producing spot welds by robot is roughly the same as that by man, but trends indicated that the robot would soon be significantly cheaper. Robots had been used very successfully in areas of difficult access, and this alone had made the job of the manual spot welder much easier (1000 spot welds per car are still done manually).

It is planned to use ten more robots for paint spraying of cars in the next 3 to 4 years, although these will be confined to underfloor and wheel-arch spraying: conventional reciprocators will be used for roof and side-body

spraying. There were no plans by Nissan to use robots for assembly in the final stages of car production. Other Nissan factories use considerably more robots than are employed at the Murayama plant, and a figure of over 50 Unimates was quoted for Oppama plant.

Quality control of the spot-welding operations was implemented by use of a three-dimensional coordinate measuring machine linked to a computer. This machine automatically checked a number of critical body dimensions and compared them with a standard: these comparisons were printed on a computer terminal at the end of the welding line. These checks are only done on an intermittent basis, say every few days. On the day of the visit, 29 May, 1979, checks had been made on the 28th, 23rd, and 18th of May.

Some 4000 of the employees at Murayama work on production which is organised into 2 nine-hour shifts. Car cycle times are about 50 seconds, and the time required to pass one new car through the plant was about 27 hours.

3.3 KAWASAKI HEAVY INDUSTRIES, HYDRAULIC MACHINERY DIVISION

3.3.1 Profile

Visits were made to both the Nishi-Kobe works and the Akashi works. The Nishi-Kobe works of the Hydraulic Machinery Division of Kawasaki Heavy Industries Ltd. was constructed in 1968 at about the time of the development of the Kawasaki high-speed high-pressure axial plunge/pump motor. In the post-war period prior to 1968, the principal products were license-built oil hydraulic components. In 1977, the division employed some 1220 employees and had sales of 23,000 million yen. The Nishi-Kobe works has a scale and product capacity which is unique in the oil-hydraulic industry in Japan: for example, there are currently 287 machine tools in a 22200m² area 6-bay machine shop. Products manufactured include bent-axis type axial plunger pumps/motors, swash-plate type axial plunger pumps/motors, screw type pumps/motors, radial plunger type low-speed high-torque oil motors, low-speed high-torque oil motors with reduction gearing, rotary actuators, valves, electro-hydraulic steering gear, oil-hydraulic deck machinery, and oil-hydraulic fishing machinery.

The Akashi works produces a wide range of engineering products including mass-produced motorcycles, compact-type engines, sophisticated industrial robots and gas-turbine engines. There are about 6000 employees and over 2000 machine tools on the site, and sales in 1975 (the only figures available) were 110 billion yen.

3.3.2 Report

Nishi-Kobe plant

The principal item of interest at the Nishi-Kobe plant was a cell of nine machine tools which was run by one operator working in conjunction with a Kawasaki-Unimate industrial robot. The cell had a rectangular plan form with the robot operating on a track along the major axis of the rectangle. One side of the cell comprised a chucking lathe, a horizontal miller, two vertical millers, a cleaner, and two drills; whilst the other side comprised a lathe, a multi-spindle horizontal drill/borer and a grinder. The function of the cell was to machine all the 44 operations on a casting for a hydraulic motor casing. All the machines were standard automatics, and the cell was well balanced in as much as very few machines were idle at any one time. New castings were loaded onto an inclined plane by the operator, after which the robot continuously worked its way up and down the cell, loading and unloading

in-process parts as required. All the sequences through the cell were monitored on a 5 x 2 mimic diagram display board, which showed the 44-operation process plan for each of the nine machine tools. This plan included a schematic drawing of the processes involved at each work station, plus a series of coloured lights which indicated the particular operation being carried out.

The main goal at this plant is that manufacturing costs must be minimized, and this is apparently being achieved by using low-cost automation developed with the workers under incentive schemes. Robots were first introduced some 6 years ago, and the plan is to use rail-mounted robots to extend the scope of their activities, in particular so that they can serve many machine tools in the manner described.

Akashi plant

The area visited in this plant was concerned with robot manufacture and testing. Manufacture of Unimates under license commenced some 10 years ago, since when about 700 Unimates have been sold (mainly in Japan): about 40 have been exported to the USSR, Korea, Australia, and to Unimation. Approximately 90% of all the robots sold have been used for spot-welding applications.

The Kawasaki-Unimate Robot System (see section 3.3.3) was developed at Akashi and is being manufactured there. All controls and bodies in the range were in evidence including the small 3030 robot suitable for palletizing work, the 6060 multi-arm system suitable for spot welding in the car industry, and the **42/**43 for continuous-path spray painting. It is understood that a new model (8645?) is being developed for high-speed continuous-path work. Other new systems will include a continuous-track conveyor with an intelligent robot synchronized to a car track for continuous application of spot welds. It was learned that Kawasaki have attempted to use TV cameras and parts-orienting devices in an intelligent robot but that this was not a viable proposition due to the high cost of manufacture. It was the view of the design engineers that widespread automatic assembly of mechanical components by robots is some way off, and that the next logical step is the major application of robots in flexible manufacturing systems.

3.3.3 Robot manufacture

Kawasaki-Unimate Robot System

For some years now, Kawasaki have been manufacturing the Unimation Unimate

polar-coordinate series of robots. In addition, Kawasaki have been developing a comprehensive range of robots under the name of the Kawasaki-Unimate Robot System which provides well-matched combinations of controllers and main bodies. Each combination is identified by a four-digit number of the form "abcd" where "ab" is a body identifier (20,30,40,50,60,70) and "cd" is a controller identifier (30,40,50,60). A range of specifications for these bodies and controllers is illustrated in Figs. 3.3.1 to 3.3.7.

The six types of body fall into three different coordinate categories: 20, 40 and 50 are polar-coordinate devices, 30 is a Cartesian-coordinate device, whilst 60 and 70 are revolute devices. The four types of control are the large-memory capacity high-performance type (30), the velocity and path control type (40), mini-computer control type (50), and group control type (60). Thus, for example, the second character "b" denotes the number of controlled axes (0 for 5 axes, 2, 3, 4, 5, 6, 7 or 8 for 2, 3, 4, 5, 6, 7 or 8 axes), and the second character is a classification code in the range 0 to 9 (usually 0). Thus, for example, the 5030 robot system is a polar-coordinate type with five controlled axes and has a high-performance controller with large memory capacity.

The **30 high-performance controller has a standard memory capacity of 510 commands (with options up to 2046) which can be divided, combined, or selected to give program flexibility: in addition, there is a built-in tester for self-diagnosis which facilitates adjustment and maintenance operations. The **40 controller is provided with functions to control continuously both path trajectory and velocity, and is able to carry out complex movements. Sophisticated tasks in complex systems can be achieved using the **50 which is based on a mini-computer utilizing a range of software modules. Group control of a number of robots and ancillary equipment is possible with the **60 controller which, in its standard form, can control up to 32 axes.

The most common bodies are the three polar-coordinate models (20**, 40**, 60**) which vary in load and operation ranges. There are 5-axis and 6-axis types, with floor, hanging, base-trunk traverse, or overhead-traverse fixture positions. Model 30** is particularly suitable for palletizing as the basic motion is along Cartesian coordinates. The swinging motion of the revolute type models 60** and 70** makes them particularly suitable for high-velocity movement of operations in which a number of robots are installed in one work stage, say a spot-welding station or a painting booth.

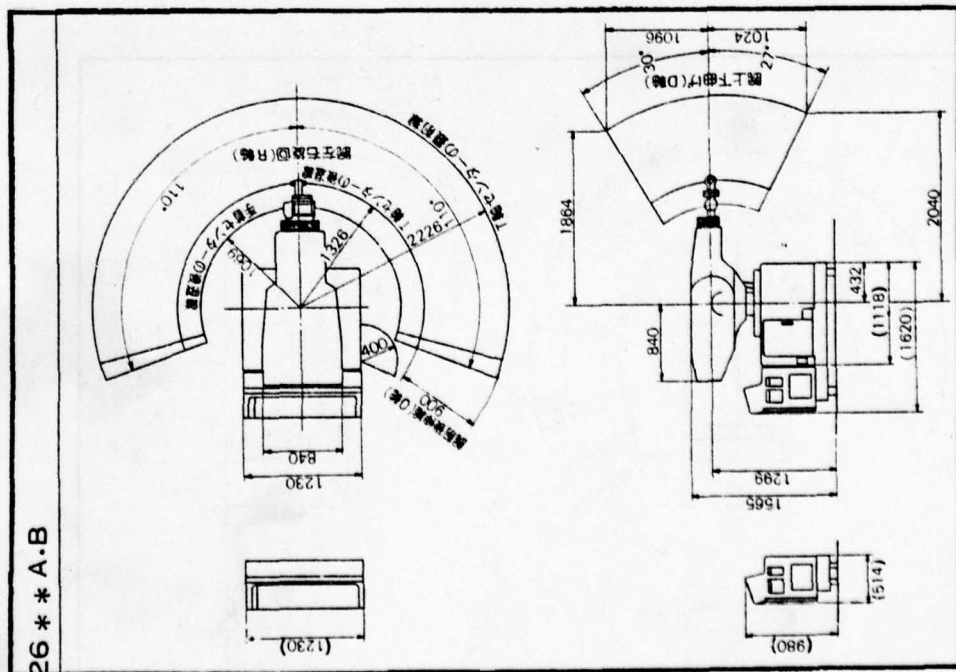
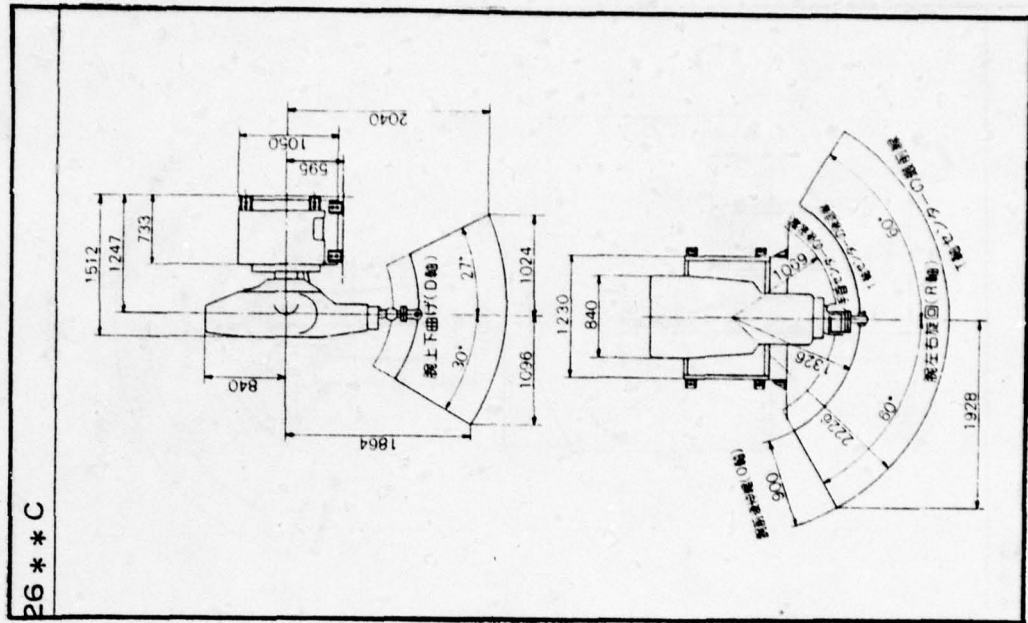

FIG. 3.3.3.2 KAWASAKI-UNIMATE SERIES 26 ROBOT MAIN BODY

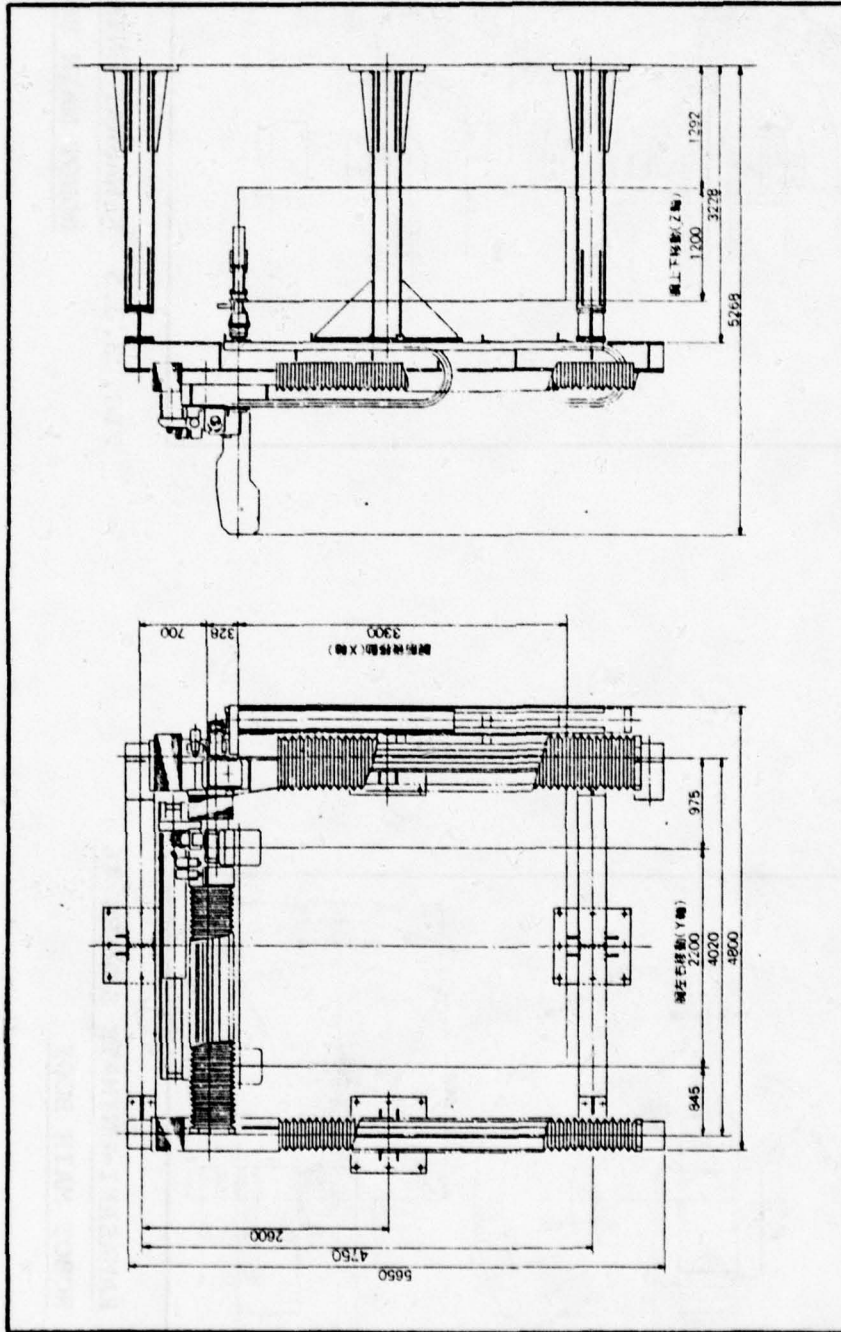

FIG. 3.3.3 KAWASAKI-UNIMATE SERIES 30 ROBOT MAIN BODY

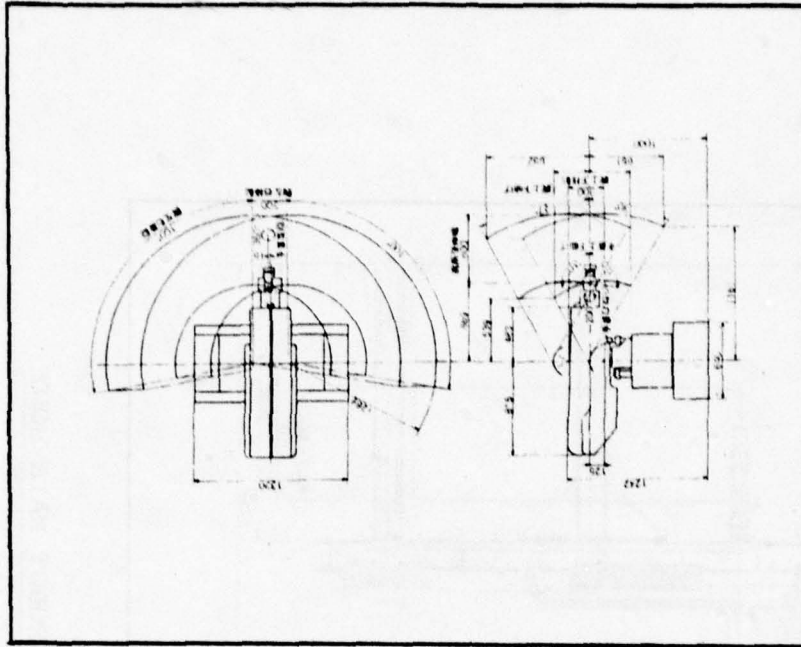

FIG. 3.3.3.5 KAWASAKI-UNIMATE SERIES 50
ROBOT MAIN BODY

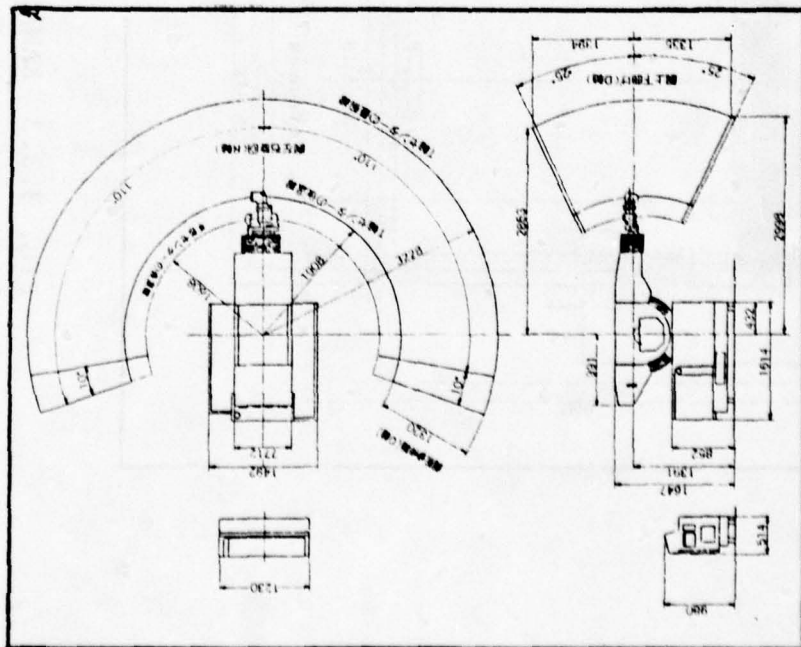

FIG. 3.3.3.4 KAWASAKI-UNIMATE SERIES 46
ROBOT MAIN BODY

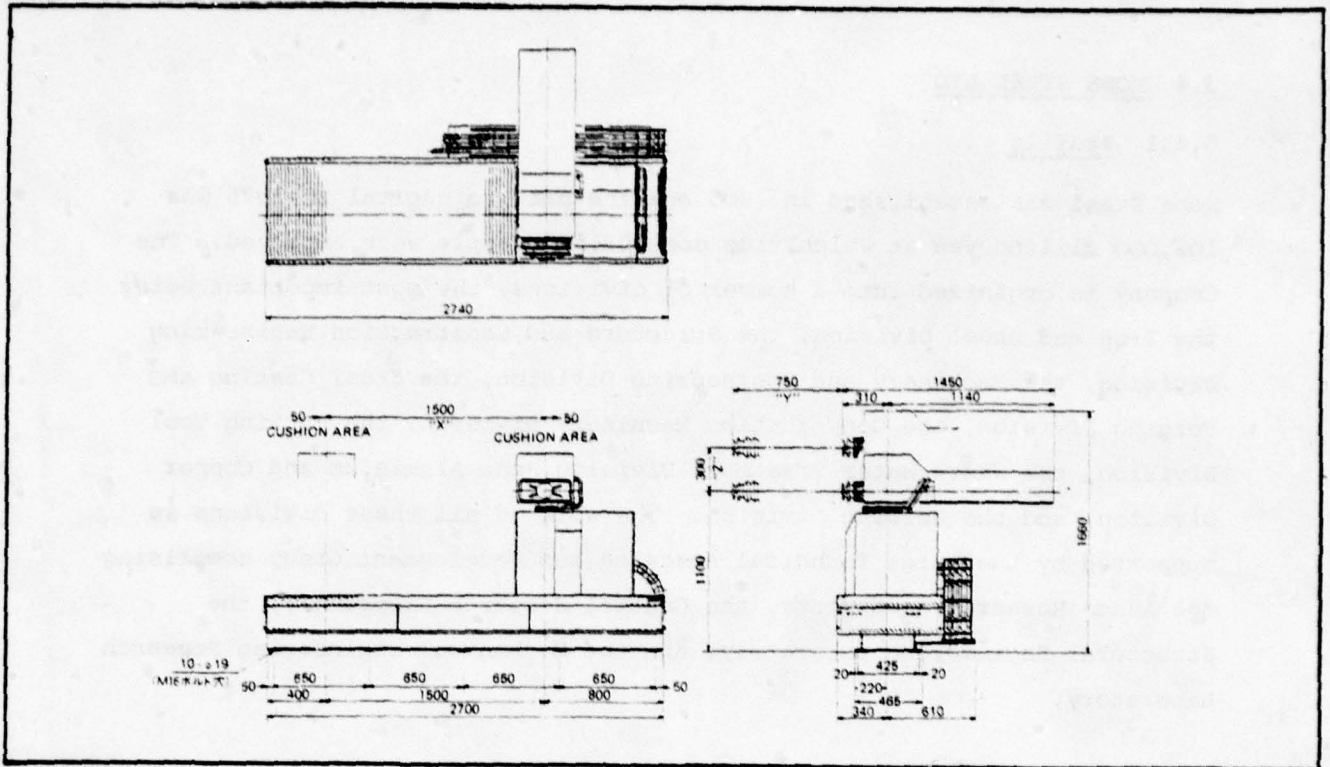

FIG. 3.3.6 KAWASAKI-UNIMATE MODEL 3330

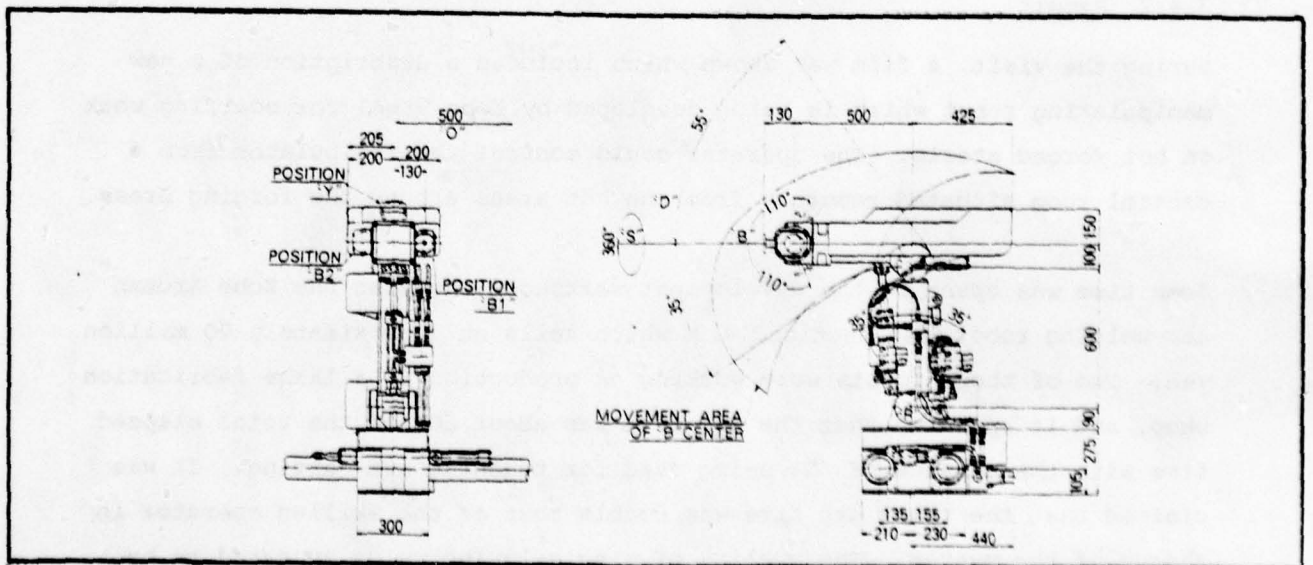

FIG. 3.3.7 KAWASAKI-UNIMATE MODEL 6060

3.4 KOBE STEEL LTD

3.4.1 Profile

Kobe Steel was established in 1905 and the paid-in capital in 1975 was 102,000 million yen at which time some 33,500 people were employed. The Company is organized into a number of divisions, the most important being the Iron and Steel Division, the Structure and Construction Engineering Division, the Machinery and Engineering Division, the Steel Casting and Forging Division, the Construction Machinery Division, the Cutting Tool Division, the Waste Water Treatment Division, the Aluminium and Copper Division, and the Welding Division. The work of all these divisions is supported by the large Technical Research and Development Group comprising the Asada Research Laboratory, the Central Research Laboratory, the Structural Engineering Laboratory, and the Mechanical Engineering Research Laboratory.

The study tour visit was to the Kobe plant of the Machinery and Engineering Division: principal activities of this division include steel making and metal processing, minerals processing, chemical engineering, manufacture of plastics and rubbers, atomic energy, power generation, materials handling, and labour saving devices. The latter activity is based at Kobe and includes the design, development and manufacture of automatic marking equipment; robots for marking, painting, welding, washing and scarfing; welding positioners; and material handling equipment.

3.4.2 Report

During the visit, a film was shown which included a description of a new manipulating robot which is being developed by Kobe Steel for scarfing work on hot forged steels. The operator could control the manipulator from a control room situated remotely from the hot areas around the forging press.

Some time was spent in the development workshops studying the Kobe Arcman arc-welding robot (see section 3.4.3) which sells at approximately 20 million yen. Two of these robots were working on production in a large fabrication shop, and it appeared that the arc time was about 60% of the total elapsed time with the balance of 40% being used for teaching and waiting. It was claimed that the robot arc time was double that of the skilled operator in charge of the system. The quality of single-laying welds appeared to be satisfactory, although some difficulties were being experienced in achieving good quality multi-laying welds.

No Kobe-Trallfa robots were seen, but it is understood that about 50 have been sold at a unit price of 10 million yen. Only 3 Arcman robots had been manufactured up to April 1979, and all are in use at Kobe Steel: the selling price is expected to be about 20 million yen.

3.4.3 Robot manufacture

Kobe-Trallfa Robot

The Kobe-Trallfa robot is an electronically-controlled spray-gun manipulator designed specifically for coating applications under a technical tie-up with the Trallfa Company of Norway. It has a reputation for high reliability, and programming is relatively easy even for complicated spray-gun coating operations. The robot consists of a manipulator unit, a hydraulic pressure unit, and a control panel (see Fig.3.4.1). The manipulator is similar in construction to the human arm and has control over a horizontal swing of 93° , a back-and-forth motion of 1 metre, and a vertical motion of 2 metres. In addition, the wrist has two degrees of rotational freedom about the main arm involving 210° of movement in both pitch and yaw, and an on-off control of the spray-gun. The spray-gun operator programs the robot using both the teaching handle installed at the top of the robot and the auxiliary handle for spray-gun operation. The operator guides the spray gun through all the necessary movements and checks the coating quality. On receiving the playback signal, the robot duplicates the taught motion. A continuous-path control system permits smooth playback, and the memory facility, using magnetic cassette tape, has a maximum programmable time of 20 minutes. There are two tape reader systems. Firstly, the Single Cycle Tape (SCT) system on which an 80 second single program can be stored. Secondly, the Random Program Selection (RPS) system equipped with 2 to 4 cassettes: the program storage capacity is up to 180 program-seconds (1 program x 180 second to 15 programs x 12 seconds). The robot can be connected to a variety of peripheral equipment, and its speed of operation can be synchronised to match the timing of turntables, conveyors, and other transport systems.

Kobe Arcman Robot

The Kobe Arcman robot is a computerized carbon dioxide arc-welding robot with six degrees of freedom. It consists of a manipulator unit, a hydraulic pressure unit, a control panel with a programmer unit, a welding programmer, and a welding unit (see Fig.3.4.2). The motion range of the arm is 60° of rotation about a vertical axis, 70° of fore-and-aft swing about a horizontal axis, and 36° of pitch on the forearm. The wrist has three degrees of freedom with 240°

of swing, 70° of bending, and 120° of twisting. The robot is of the teach-in/play-back type. In the teach-in mode, the operator is required to trace the welding line without any limitation on tracing speed and to set-up the welding parameters such as welding current and voltage, welding speeds, oscillating (weaving) patterns and shift distance (for multi-layer welding). The control system is based on a 9k 16-bit micro-computer with 250k of floppy-disc storage, and features various data editing functions. Up to 25 programs can be stored with a maximum capacity of 10 minutes using constant time sampling or 60 metres using constant distance sampling. In addition, the Arcman controller can detect and correct the welding line using the electrode as a detector.

Kobe Automatic Marking Device

Kobe Steel first supplied automatic marking devices in 1972, and have now completed five kinds of such devices. Their principal use is for marking of letters, figures, and symbols on the surfaces of all kinds of steel products such as plates, slabs, coils and pipes. Uniform marking can be achieved on rough surfaces, curved surfaces, and slanting surfaces. The writing head of the marking device is controlled by a micro-computer and a variety of input devices can be used as a source of data. A variety of stencil types are provided ranging in size from 6 to 150mm, and from 2 to 3 lines of 20 to 30 letters can be drawn at speeds from .05 to 3 seconds/letter using a variety of inks and paints.

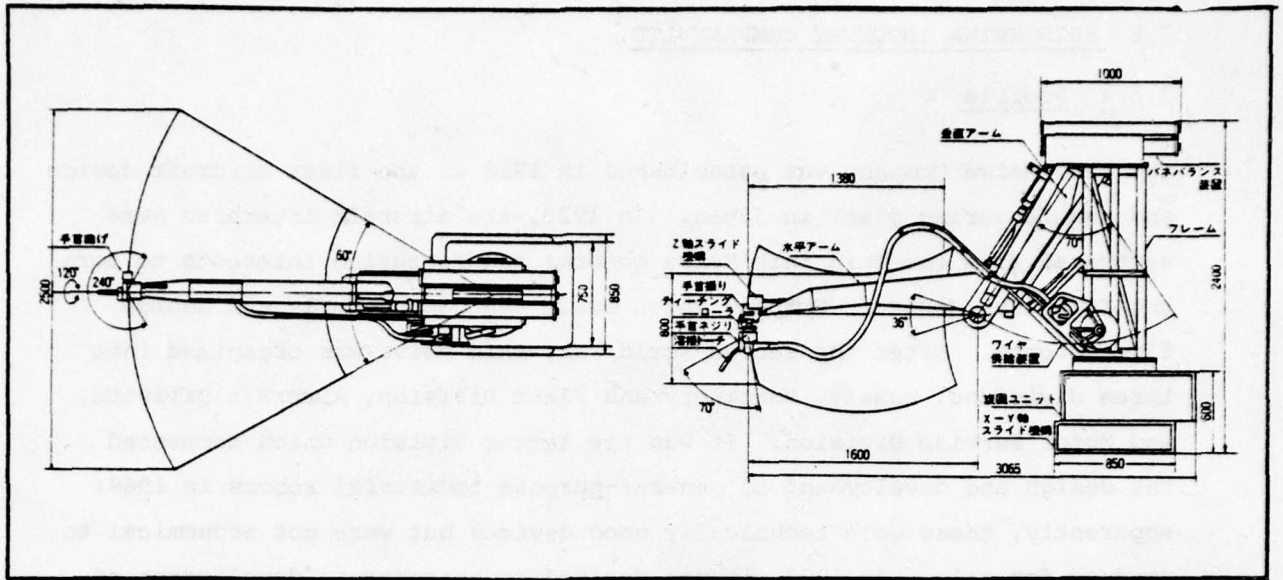

FIG. 3.4.1 KOBE-TRALLFA SPRAY-GUN MANIPULATOR

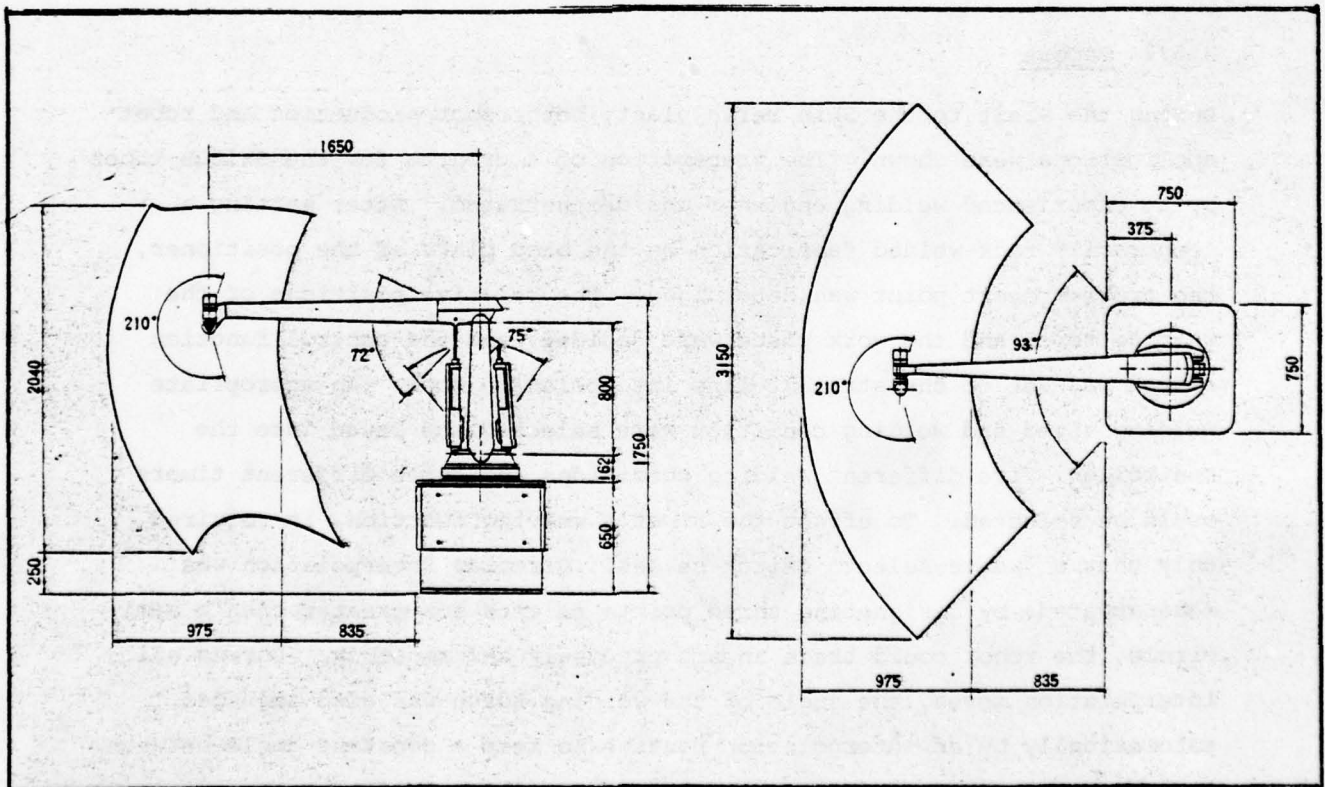

FIG. 3.4.2 KOBE ARCMAN ARC-WELDING ROBOT

3.5 SHIN MEIWA INDUSTRY COMPANY LTD.

3.5.1 Profile

The Shin Meiwa Company was established in 1918 as the first aircraft design and manufacturing plant in Japan. In 1928, the aircraft interests were separated from the main Shin Meiwa general manufacturing interests to form the Kawanishi Aircraft Company which built the famous Emily and George flying boats. After the second world war, Shin Meiwa was organised into three divisions, namely, Machinery and Plant Division, Aircraft Division, and Motor Service Division. It was the latter division which commenced the design and development of general-purpose industrial robots in 1969: apparently, these were technically good devices but were not economical to produce for sale. In 1972, it was decided to concentrate development of industrial robots on special-purpose units, and in particular on arc welding robots such as the current PW150 and 750 series (see section 3.5.3). All the Shin Meiwa welding robots are designed such that the torch always faces downward in order to give uniform weld quality. Both series of robots have large capacities and cost in the range \$100,000 to \$130,000 excluding the welding torch, welding power units and electrode feeders.

3.5.2 Report

During the visit to the Shin Meiwa plant, both robot production and robot applications were shown. The preparation of a program for the PW150B robot by an experienced welding engineer was demonstrated. After setting a temporarily tack-welded fabrication on the base plate of the positioner, the program start point was determined. The relative positions of the welding torch and the work piece were decided, and the control function switch was set to the straight-line interpolation mode. An appropriate welding speed and welding condition were selected and keyed into the controller: five different welding conditions and three different timers could be selected. To effect the robot's weaving function, it required only that a 'weave select' switch be set. Circular interpolation was demonstrated: by designating three points on arcs not greater than a semi-circle, the robot could trace an arc precisely and smoothly. During all interpolation moves, the angle of the welding torch was also adjusted automatically by an interpolation routine to keep a constant angle between the torch and the weld line. A number of the large PW150 robots were in operation in the fabrication shop, mostly producing circumferential welds on discs some 2 metres in diameter. In all cases, the quality of the welds

appeared to be of high quality and were of a repeatable form.

A new development of torch/workpiece proximity sensing and guidance was explained. The electrode of the torch could be used as a voltage/current detector and, knowing the geometry of the workpiece in the vicinity of the electrode touchdown, a microprocessor could compute the exact nature of the geometry (e.g. a right-angle between two plates or an obtuse angle between two plates). This enabled the electrode to be positioned optimally with respect to the workpiece at all times, thus improving the weld quality during weaving and multi-laying.

3.5.3 Robot manufacture

Shin Meiwa Robot Welder PW150 Series

The PW150 Series of robot welders are designed specifically for arc welding applications. The design is extremely modular and comprises a torch stand, a torch wrist, a positioner, a control unit, a remote control box, a face plate, and welding equipment (see Fig.3.5.1). The torch stand has three degrees of freedom (X,Y,Z) and is carried on a large portal frame: the ranges of the X, Y, and Z axes are 1500mm (side to side), 1000mm (fore-and-aft), and 1000mm (up and down), respectively. The torch wrist has two degrees of freedom (α, ϕ) on the model PW150A and one degree of freedom (α) on the model PW150B, and change in the torch angle does not move the welding point: the ranges of the α, ϕ variables are 40° to 80° and 0° to 560° , respectively. The positioner, which is geared to the torch stand, moves the part to be welded and has two degrees of freedom (T, θ). The T axis pitches the positioner through 400° whilst the θ axis yaws the positioner, also through 400° . The model PW150A has a face-plate positioner on both sides and is suitable for cylindrical parts, whereas the model PW150B has a crank-shaped positioner capable of doing all welding using face-downward positions. The control unit comprises a microcomputer controlling five axes on the PW150A and seven axes on the PW150B. A remote control box is used as a programming device to set the location of the torch, speed of each axis, and operating conditions such as arc interpolation, straight line interpolation, and weaving. Programs can be stored on a cassette recorder.

Shin Meiwa Robot Welder PW751

The PW751 robot welder is designed for arc welding operations. It has a modular construction comprising a welding robot main body, a vertical pillar, a torch wrist, a control unit, a remote control box, a face plate, and

welding equipment (see Fig.3.5.2). The main body has two degrees of freedom (X,Y) with ranges of 750mm (fore-and-aft) and 750mm (side to side), respectively: the face plate is mounted on the main body, and has a single degree of freedom (θ) in rotation about the y-axis with a range of 400° . Vertical motion, Z, is achieved by 750mm of up-and-down motion of a horizontal arm mounted on the fixed vertical pillar: the torch wrist is mounted on this horizontal arm and has one-degree-of-freedom (θ) with a range of 560° about a vertical axis. Control is by a microcomputer and programming is by the taught-in/play-back method with program storage on a cassette recorder.

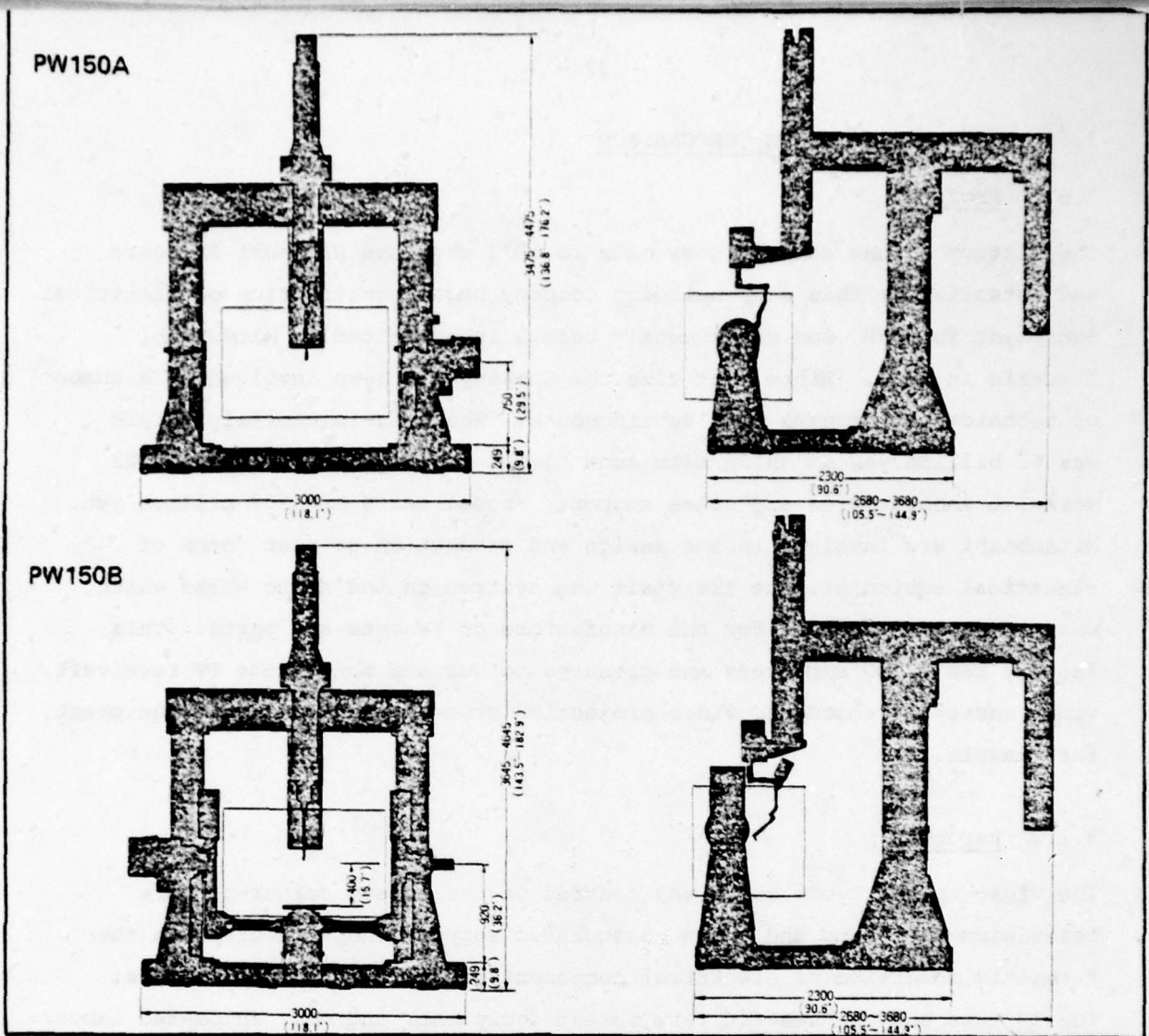
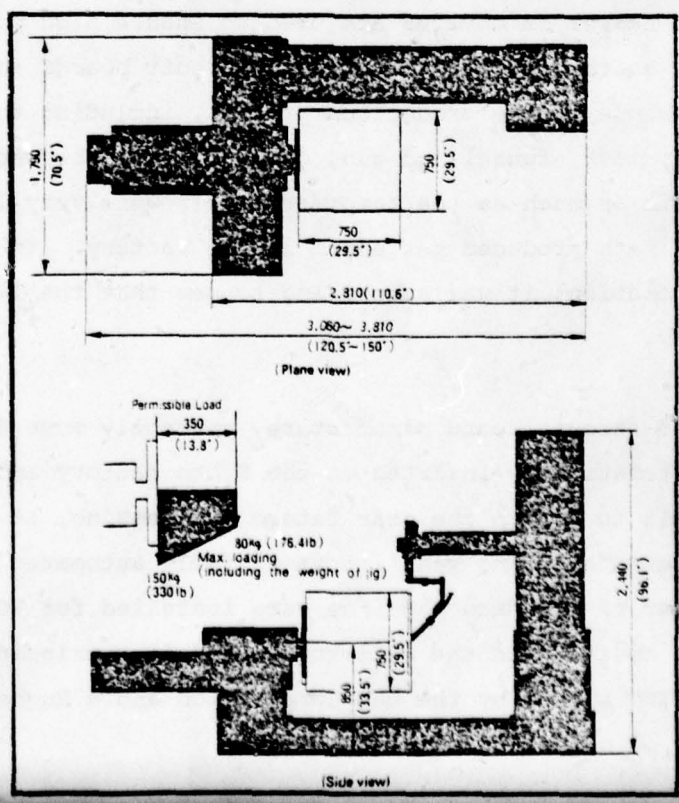

FIG. 3.5.1 SHIN MEIWA ROBOT WELDER PW 150 SERIES



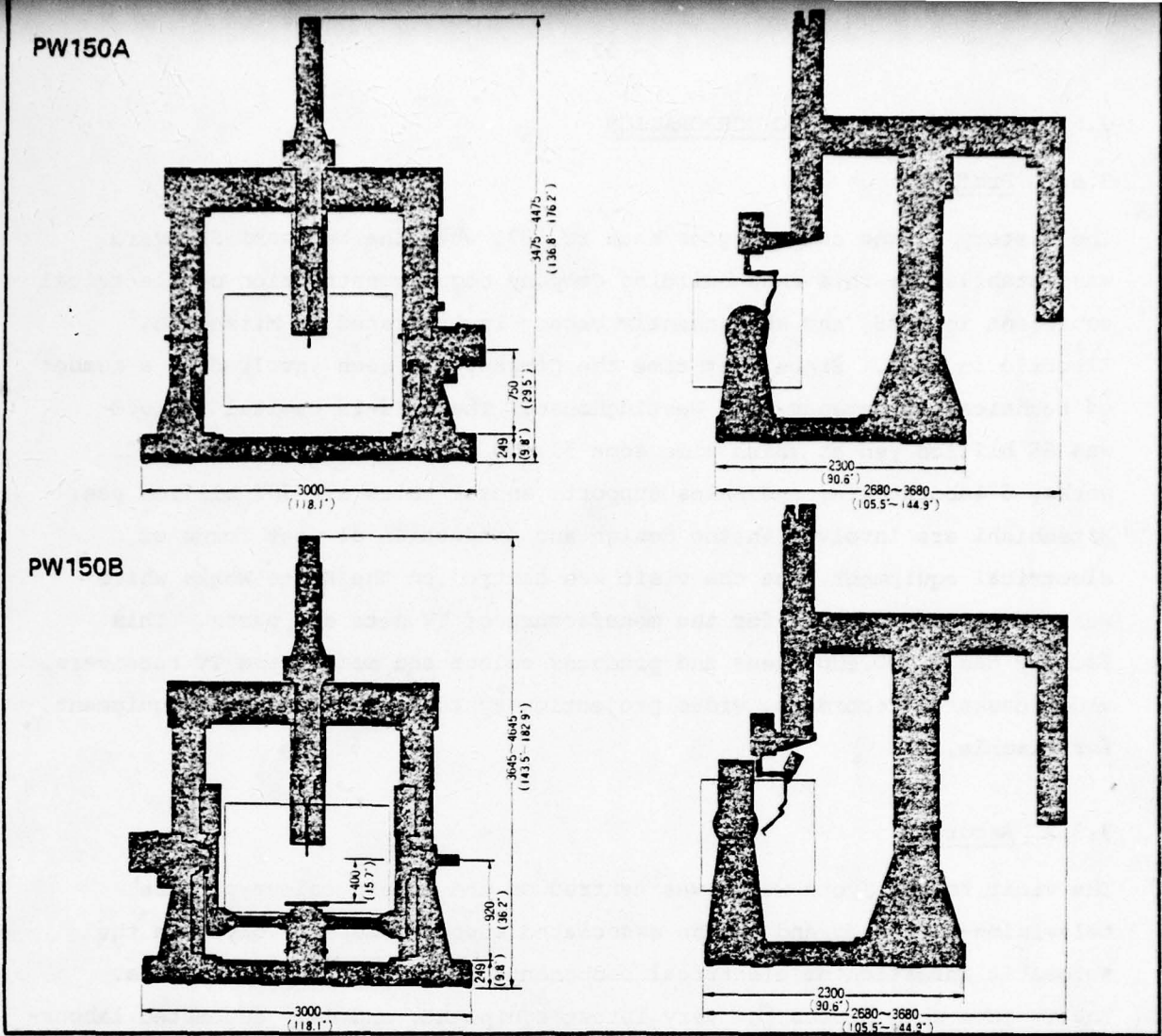

FIG. 3.5.1 SHIN MEIWA ROBOT WELDER PW 150 SERIES

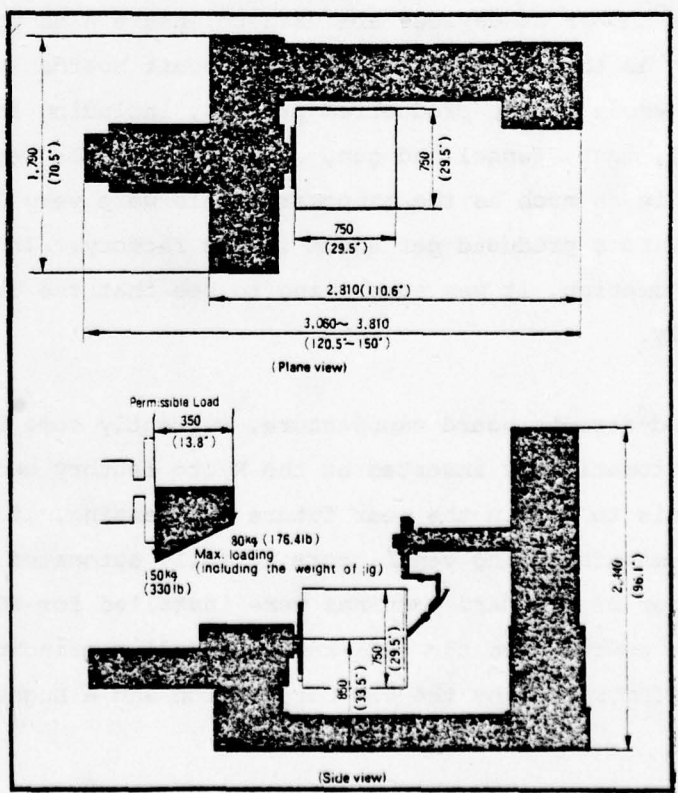

FIG. 3.5.2 SHIN MEIWA ROBOT WELDER PW 750

3.6 MITSUBISHI ELECTRIC CORPORATION

3.6.1 Profile

The history of the company goes back to 1871 when the Nagasaki Shipyard was established: this ship-building Company began construction of electrical equipment in 1898, and subsequently became incorporated as Mitsubishi Electric in 1921. Since that time the Company has been involved in a number of technical agreements with Westinghouse. The paid-in capital in 1978 was 65 billion yen at which time some 51,000 people were employed in 23 works, 6 laboratories and sales support: annual sales are 792 billion yen. Mitsubishi are involved in the design and production of most forms of electrical equipment, but the visit was centred on the Kyoto Works which was established in 1962 for the manufacture of TV sets and parts. This factory has 2,000 employees and produces colour and monochrome TV receivers, video cassette recorders, video projection systems, and car audio equipment, for example.

3.6.2 Report

The visit to the Kyoto works was centred on the modern colour-picture television-tube shop and on the associated support shops involved in the automatic insertion of electrical components in printed circuit boards. The TV-tube shop houses the very latest equipment, and many automated labour-saving techniques have been installed for such processes as the inspection of products, assembly, and shipment: all these are carried out under computer control. A large number of devices are used to ensure high production reliability, such as those for aging printed-circuit boards and for automatic inspection. The whole of the production process, including the manufacture of the tube panel, mask, funnel and gun, could probably be regarded as an industrial robot in as much as the manpower levels were very low in relation to the 800,000 TV sets produced per annum in the factory. In view of the high-level of automation, it was surprising to see that the TV sets were assembled manually.

Turning to printed-circuit board manufacture, currently some 85% of all PCB components are automatically inserted at the Kyoto factory and the intention is to increase this to 95% in the near future (in passing, it was stated that the Iida factory manufacturing ventilators is fully automated and under computer control). A number of standard machines were installed for PCB operation, and most of these operated on the well-known bandolier principle: these machines included a Dyna/PTRC system by the USM Corporation and a Hughes 200NC

Industrial Systems Division automatic tester. In addition, there were at least two Mitsubishi-designed machines for assembling bandoliers of components using computer control to select the ordering of the components.

There was also a long line of special-purpose pick-and-place robots, again designed and manufactured by Mitsubishi Electric, and which was under the control of a mini-computer. These robots were able to manipulate the more difficult components such as small transformers and fuses, in addition to resistors and transistors. Melcom 70 computers were used to control the line, and it was evident that the overall line was extremely flexible since it could be reprogrammed on-line in approximately two hours if a totally new printed circuit board is to be handled. These special-purpose robots are not available commercially.

3.7 TOYOTA MOTOR CO. LTD.

3.7.1 Profile

The Toyota Motor Company was established in 1937, being based on the automobile department of the Toyoda Automatic Loom Works. In January, 1979, the paid-in capital was 77 billion yen at which time some 45000 people were employed: sales in 1977/1978 were 13 billion US dollars. The Company has three car assembly plants, two truck assembly plants, one engine plant, and four chassis/parts plants. Toyota is the largest automobile manufacturer in Japan (2,929,157 vehicles in 1978) and was the third largest automobile manufacturer in the world in 1977 (2,720,758 vehicles compared with GM at 6,702,820 vehicles and Ford at 3,741,875 vehicles). The visit was to the Kamigo plant in Toyota City near Nagoya. This plant has casting, machining and stamping shops and its principal products are engines and transmission units.

3.7.2 Report

It was explained that there are about 300 robots in use in the whole of Toyota, and that about 40 to 50 are used in each plant, most of these being involved in spot welding. The visit was somewhat disappointing as it was conducted by public relations officers rather than by engineers. The main production equipment seen was an engine production, assembly and test plant. The production process was completely unmanned as was the test cell which could fully exercise about 30 new engines every 20 minutes. Assembly of the engines was done manually, but under extremely good working conditions. In the plant, there were a number of plug-board programmed robots based on a cylindrical-coordinate axis system and simple wrist in/out functions. Some of these robots are manufactured by Kyohoseisakuja, a company associated with Toyota, but are not sold outside the Toyota organization.

3.8 NIPPONDENSO CO. LTD.

3.8.1 Profile

The Nippondenso Company was established in 1949 as a manufacturer of electrical automotive components. The forerunners of the Company were the electrical and radiator departments of the Toyota Motor Company: in 1953, the Company entered a technical link with Bosch of West Germany and entered into a license agreement to manufacture Bosch equipment. Currently, 38% of sales involve car heaters and air conditioners, 30% of sales involve electrical automotive equipment, and the remainder of sales comprise radiators, meters, safety items, emission control devices, filters, fuel injection systems, spark plugs and other miscellaneous items. The paid-in capital in 1977 was 9.6 billion yen at which time there were approximately 20,000 employees. There are plants at Kariya, Ikeda, Hiroshima, Anjo, Nishio, and Takatana. The visit was to the Anjo and Takatana plants of Nippondenso.

3.8.2 Report

Brief visits were made to two plants of Nippondenso, namely, the Anjo plant manufacturing starter motors, alternators, magnetos, dynamos and distributors, and the Takatana plant manufacturing dashboard meters, monitoring equipment, air cleaners and oil filters.

At Anjo, interest focussed on the die-casting shop which housed approximately 16 die-casting machines each serviced on either side by two industrial robots, both of which were designed and manufactured by Nippondenso. One of these robots was handling the transfer of alloy melt from a storage bowl into the die-casting machine: this device could equally well have been called a mechanism rather than a robot. The other robot was being used to spray lubricant into the dies, to remove the finished die-cast components, and to place these parts into a machine to trim the die flashes off. Manning levels appeared to be of the order of six to eight operators, and the shop was extremely clean and orderly, with good working conditions.

Only meter manufacture and dashboard manufacture were seen at Takatana. All the meters were manufactured on a flow-line basis which was heavily automated, with only such operations as the mounting of hairsprings and the calibration of instruments being done by hand. The automation comprised principally of light-weight pick-and-place mechanisms, and the most interesting feature was that only relatively short batches of particular meters went down the line in

sequence. Each line could be programmed from a small computer, and the system was flexible enough in operation to allow for a fairly wide range of meters to be manufactured by the same set of machines. There was a control panel at the start of each line, into which the details of about 40 different batches for a particular shift could be entered using thumbwheel edge switches: these details included the meter type and the batch quantity. Information on the state of each batch in terms of its progress through the system was also displayed on this panel. Batches could be processed end-on, that is, the tail-end of one batch was immediately followed by the start of the next batch, with none of the pick-and-place mechanisms remaining idle for a substantial duration of time.

3.9 MITSUBISHI MOTORS CORPORATION

3.9.1 Profile

The history of the Mitsubishi Motors Corporation goes as far back as the government-owned Nagasaki Iron Works (1868) and Ship Yards (1871). Cars were first produced in 1917 by the then Mitsubishi Shipbuilding Co. and subsequently by Mitsubishi Heavy Industries in 1934. Car production was rationalized under the new corporation in 1970. The paid-in capital in 1977 was 35 billion yen at which time some 22,000 people were employed. Annual sales in 1977 were 741 billion yen. There are a number of works including the Nagoya Oye plant (cars, buses, commercial vehicles, jeeps), the Nagoya Okazaki plant (cars), the Mizushima plant (cars, trucks, engines), the Kyoto plant (cars, industrial and agricultural engines), the Tokyo Kawasaki plant (heavy-, medium-, and light- duty trucks, buses, engines), the Tokyo Nakatsu plant (industrial engines), and the Tokyo Maruko plant (heavy-duty trucks and special vehicles). The two main centres for research and development are the passenger car engineering centre (Okazaki and Kyoto) and the truck and bus engineering centre (Kawasaki). The study-tour visit was to the Okazaki plant which is probably the most up-to-date automobile production plant in the world.

3.9.2 Report

The visit was to the Okazaki plant of the Nagoya Motor Vehicle Works: this plant was completed in 1977 and has 3300 employees engaged in the manufacture of the Galant Sigma and Lambda series and the Celeste series. The output capacity is some 15000 cars per month using a two-shift system, with the balance of time being used for routine and preventative maintenance. Labour-saving equipment is used extensively throughout the plant from the press shop, through body assembly and painting, right up to the final assembly line. The layout of the lines is entirely sequential and buffer stocks on the production floor have been eliminated. Automation is used in about 75% of the plant's operations, and rapid changeover of tooling can be made to enable a variety of model types and variants of types to be manufactured on the same line. The factory is fully air conditioned and is extremely bright, clean, and well laid out: working conditions appeared to be excellent throughout.

The body stamping shop contained Hitachi Zosen presses, Komatsu presses and USI presses, all operating in an integrated manner with large robots loading and unloading stampings on to and off the presses, and transferring parts

between presses and on to the output tracks to the assembly shop. Each press had a wide range of gripper hands for the robots, and tool changing, assisted by the robots, typically took between three and ten minutes. The body assembly line housed 77 robots and employed some 60 men on each shift. 80% of the robots were engaged in spot welding, with the remainder devoted to simple arc welding and to parts manipulation. The majority of robots in the shop were manufactured by Mitsubishi Heavy Industry and were controlled by Mitsubishi Robitus RC controllers. Most of the robots operated on a large portal frame spanning the incomplete body assembly and had five degrees of freedom: three orthogonal linear movements, and two rotational movements in yaw and roll. In addition, the wrist had two degrees of freedom in rotation. All the motion was powered by hydraulic drives with analogue controllers.

A large part of the spot welding line was completely unmanned, and a typical group of operations would be done on a series of work stations. For example, one group comprised five work stations with two robots at station 1, three at station 2, two at station 3, two at station 4, and one large 4-armed robot at station 5. This particular group accepted three parallel lines of input from other robot stations: the input consisted of the left- and right-hand side sub-assemblies and the floor sub-assembly. These three sub-assemblies were orientated, offered up together, and spot welded into a larger sub-assembly. The latter stages of the welding shop were more intensively manned, at positions in the car where the welding was to be done in difficult and inaccessible places. Approximately, 80% of all welding in the plant is done by robot.

It is understood that two robots were operating in the paint shop, although this was not visited. At all stages in the production process, parts from stores, particularly for the engine and transmission units and for interior trim, arrived on the track only when required even though there were three different models on the track simultaneously in a variety of batch sizes. This technique, which eliminates buffer stores at the side of the track, is achieved by a computer evaluation of requirements prior to the commencement of the shift: that is, the computer planned ahead in batch mode and not in a real-time mode.

Cars are on the track for about 17 hours, and pass through 620 distinct work stations. Each shift employed about 350 operators (240 on assembly, 80 on painting, and 80 on welding). In the near future, it is planned to make up to six different models of car on the same track.

3.10 FUJI ELECTRIC CO. LTD.

3.10.1 Profile

The Fuji Electric Company was established in 1923 to manufacture electrical equipment and machinery. The paid-in capital in 1978 was 21 billion yen at which time some 14,000 people were employed. The main products of Fuji Electric can be classified as power and industrial electrical machinery, instrumentation, standard electrical products, and consumer products. There are nine main factories in Fuji Electric, and two main groups of subsidiary companies (the Fuji Group with 21 companies and the Furukawa Group with 41 companies: the latter group includes Fujitsu Fanuc Ltd). The visit was to the Mie factory which manufactures small- and medium-capacity electric motors, motor hands, home pumps, show cases, vending machines and air conditioners.

3.10.2 Report

The visit to the Mie factory was in two parts: firstly, a tour of the shop manufacturing small DC motors, and secondly, a tour of the fabrication shop engaged in the production of cabinets for automatic vending machines.

The production line manufacturing Fuji 1.5kw DC motors was unmanned except for the assembly stages of the process, and all components were loaded and unloaded to and from the machine tools in the line using a sequence of Fuji Motorised Hands and appropriate gantry arrangements (see Fig. 3.10.2). Eleven robot/gantry stations were provided in a flow-line configuration, but the motor being manufactured at the time of the visit only required the use of the first seven stations. For example, the feet of the DC motor-body casing were faced at station 1 on a horizontal milling machine, whilst station 4 comprised about ten machine tools with a twin-robot/gantry system over each of the tools. This latter station was engaged solely in operations on the motor shaft such as turning, grinding, splining, and keyway cutting. After manual assembly, the motors were run continuously during which time they were tested electrically and mechanically. Painting was done automatically, as were the stapling and labelling of the boxed motors for delivery. Paradoxically, the motors were loaded into the boxes manually.

There were two sheet-metal shops in which the Fuji vending machines were manufactured. The first was manually operated throughout and contained Yodogawa, Mori and Fujicar presses, and Amada guillotines made under

license from Promecam. The second sheet-metal shop was almost completely unmanned and utilized a high degree of automation involving guillotines, presses, turret presses and folders. The guillotines were numerically-controlled shears designed and manufactured by Fuji (see section 3.10.3), and were used to cut a variety of rectangular sheets of metal some of which had already been through the NC turret presses. Continuous rolls of sheet were being fed through a Fukui press, after which alternate components were rotated through 180° in a vertical carousel so that the line then contained both left- and right-handed parts. A number of NC turret presses followed, each controlled by a Fanuc 200B system, with up to 40 tools in the rotating tool holders. Following the operations on the turret presses, the sheet components entered Amada NC folding machines, each controlled by Fanuc 200A systems, after which the correct mix of the constituent sheet-metal parts of a vending machine cabinet arrived at manually-operated arc welding bays. The output of this highly automated plant was about 600 vending machines per day.

3.10.3 Robot manufacture

Fuji Vari-o-matic Fl Press Hand

This industrial robot was designed by Fuji Electric at the request of the Japan Metal Stamping Association, who provided the research and development funds with a view to obtaining a robot suitable for press working which could help to both reduce industrial accidents and to alleviate difficulties caused by a shortage of skilled labour. The press hand, which is illustrated in Fig.3.10.1 can be used for multi-purpose medium- and small-run production (typically involving up to five changes of set-up per day) and can be applied readily to existing general-purpose press-working machines. Production speeds of up to 30 cycles/minute can be achieved, which is comparable with that of a human operator. The robot is constructed in a modular fashion and comprises one or two arms each with up to four degrees of freedom (forwards/backwards stroke of 400mm, vertical lift of about 200mm, sideways movement of up to 500mm, and rotation about a vertical axis), a wrist with two degrees of freedom (up/down stroke of 20mm, and fixed rotation of $\pm 90^\circ$), and a finger with two degrees of freedom (forwards/backwards stroke of 20mm and open/close range of about 10°). Pneumatic power is supplied for all the degrees of freedom, and only point-to-point control is possible which is programmed using a plug-board matrix. Reprogramming time is about 10 minutes, and up to 30 minutes are required to change a die using the robot. Workpiece capacity is up to 1.4kg with maximum dimensions of 180 x 400mm with a drawing depth of

up to 50mm.

The robot can be constructed using building-block principles and the following variants are typical: twin-arm type and right/left motion (this is the standard model), fixed twin-arm type, single-arm swing type, and fixed single-arm type.

Fuji Motorised Hand

This is a rectangular-coordinate type of industrial robot with a motorised hand, and is designed and manufactured by Fuji Electric. The basic design comprises an arm driven by a rack and pinion with a stroke of 500mm, a wrist rotation unit, and a grip-and-release finger unit. This robot can be mounted on an overhead gantry which enables the gantry/robot configuration to be used for automatic loading and unloading of machine tools (see Fig. 3.10.2). A series of such configurations can be used in groups as principal components in an automatic manufacturing system such as that described in section 3.10.2. There are a number of variants of the basic robot loading unit which include both single and twin types, each with lifting capacities up to 30kg. Workpieces up to 500mm long and 120mm in diameter can be manipulated. Standard gantry sizes are up to 5000mm in span with a traverse time of about 6 seconds. Loading times for a manoeuvre such as down/grip/inching/up/traverse/down/release/up/traverse would be typically 20 to 25 seconds.

Fuji Robot System

The industrial robot marketed under the name Fuji Robot System is in fact identical to the Fujitsu Fanuc Robot-Model 2 (see section 3.1.3) and is not described further here. However, a number of Fuji-approved applications for this robot are shown in Fig.3.10.3 for completeness.

Fuji Digital Automated Shearing Line

This Digital Automated Shearing device consists of a numerically-controlled table/guillotine combination for shearing operations on sheet plates. It is intended as a labour-saving system applicable to both general-purpose operations for large-scale production and for small-batch production. Materials can be loaded by crane automatically on to the table, after which the standard manipulations of translation and rotation are carried out by grippers and robot lifters, respectively. A schematic drawing of this system is shown in Fig. 3.10.4, and its use in part of an automated production process was described in section 3.10.2.

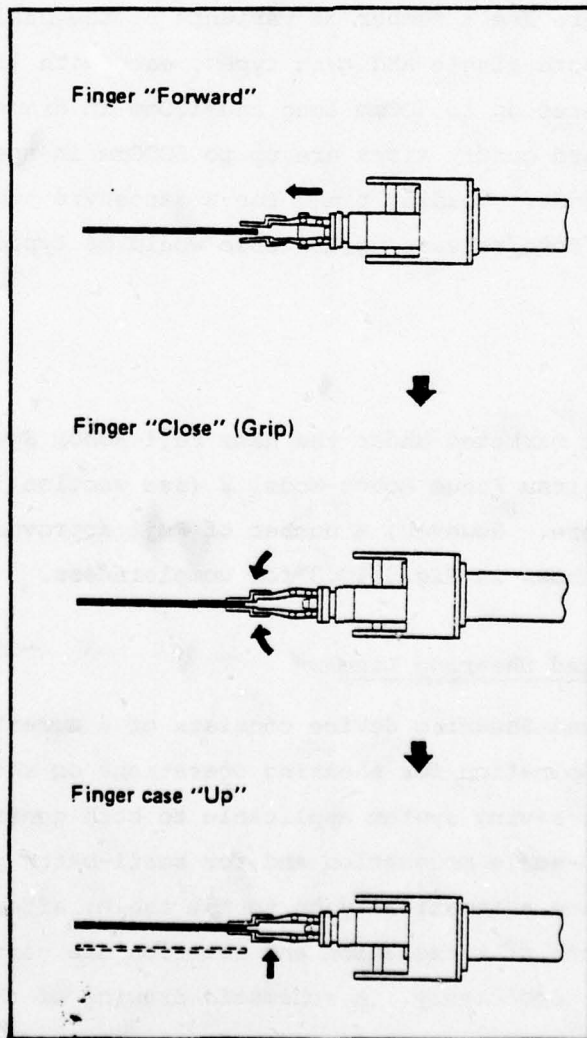
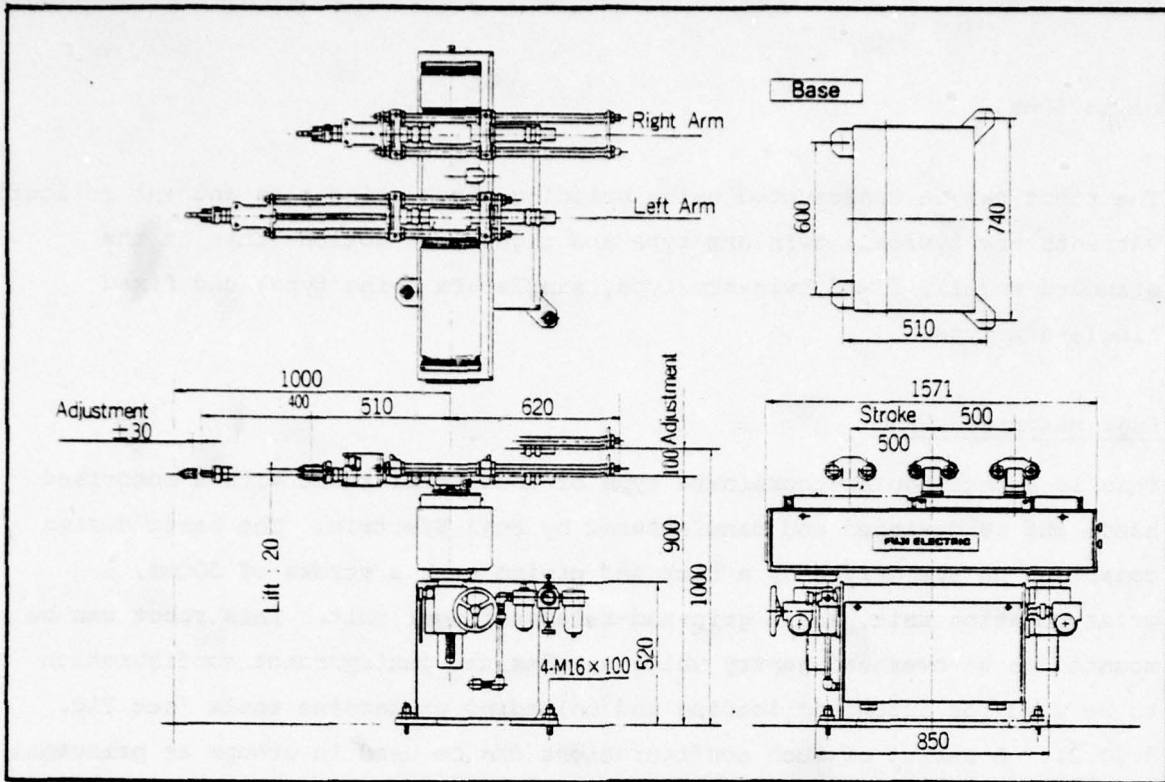

FIG. 3.10.1 FUJI VARI-O-MATIC F1 PRESS HAND

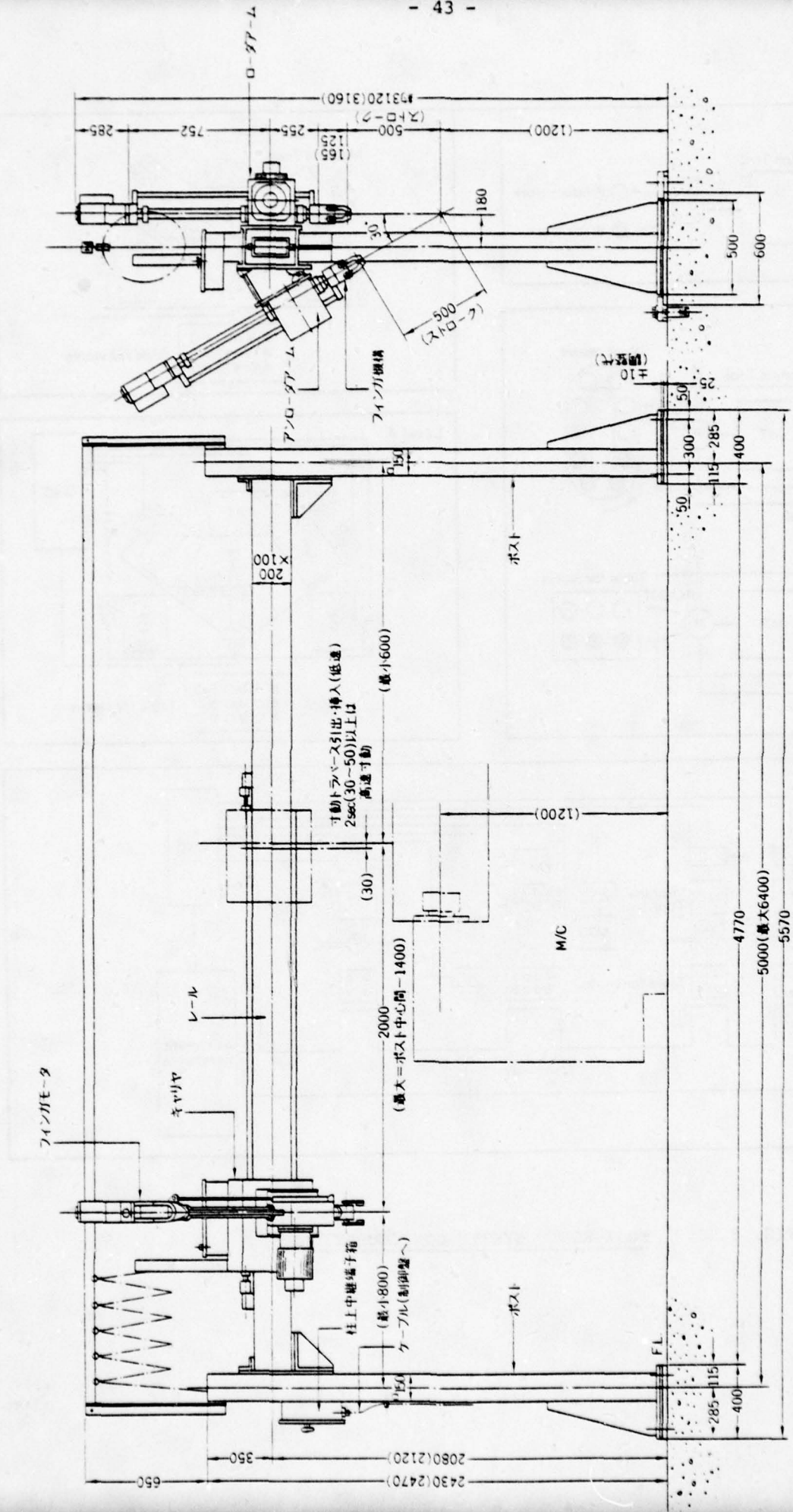

FIG. 3.10.2 FUJI MOTORIZED HAND

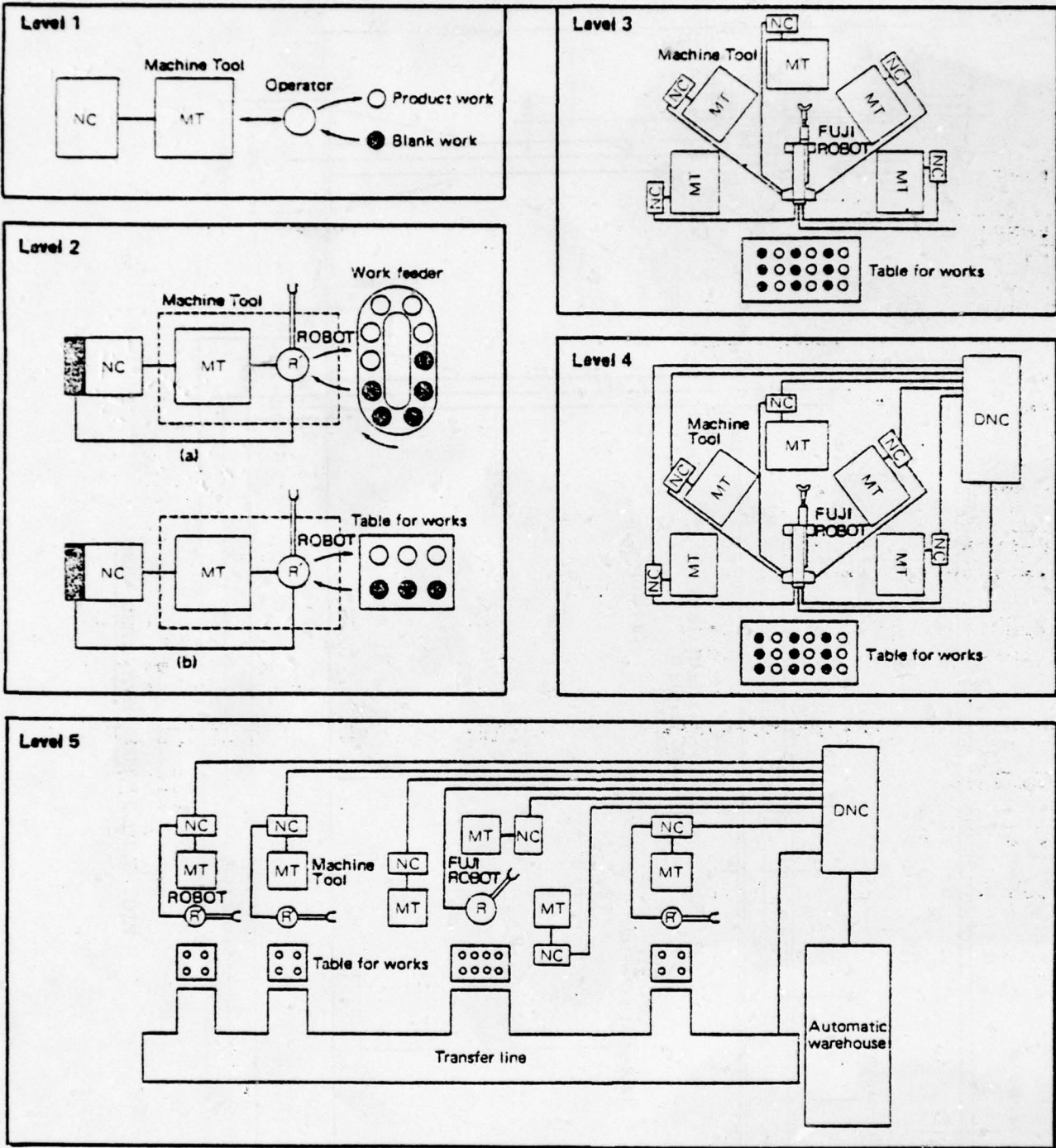

FIG. 3.10.3 FUJI ROBOT SYSTEM CONFIGURATIONS

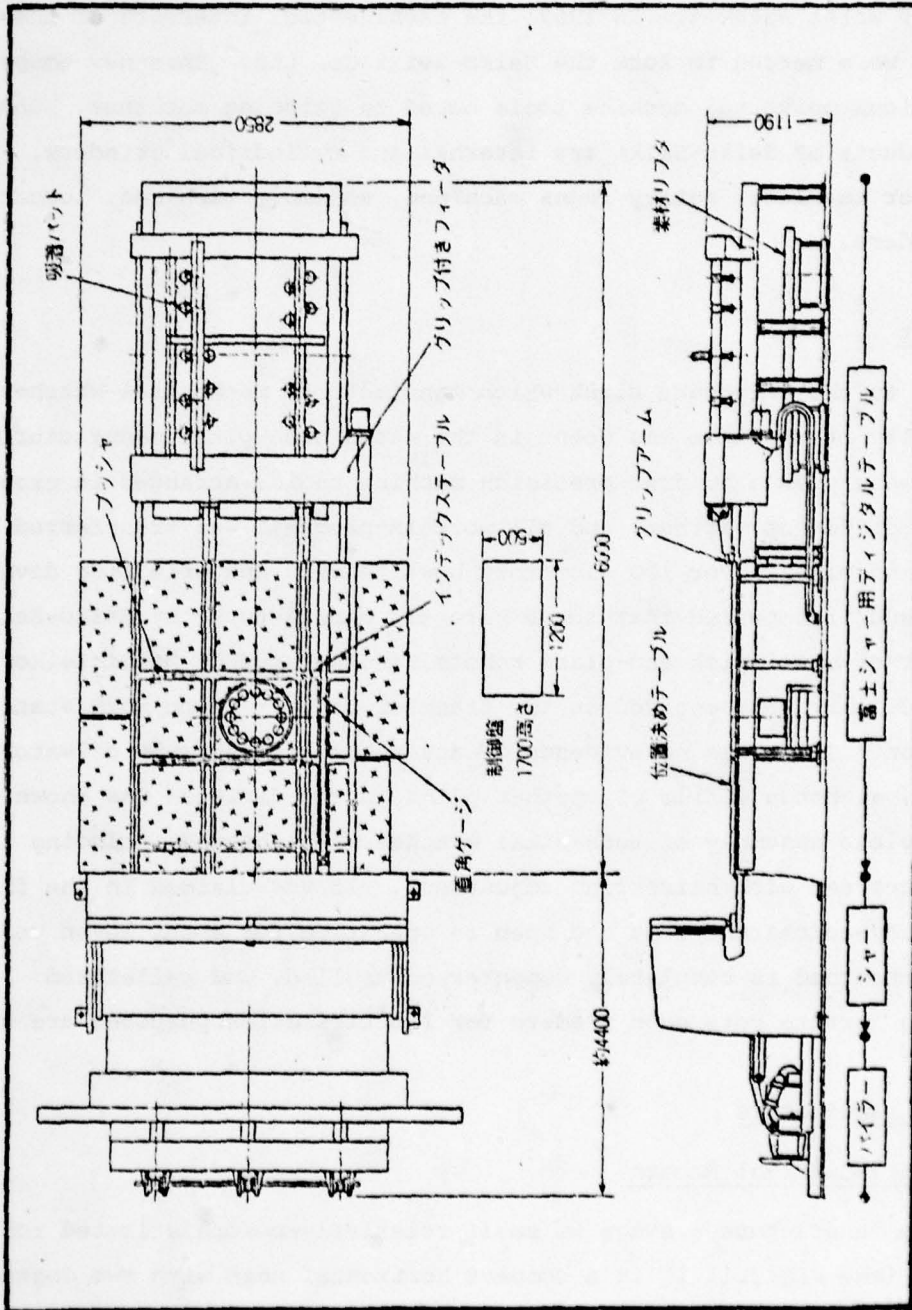

FIG. 3.10.4 FUJI DIGITAL AUTOMATED SHEARING LINE

3.11 DAINI SEIKOSHA CO. LTD

3.11.1 Profile

The Seikosha Company was established in 1892 to manufacture clocks and watches. In 1937, the company split into two divisions, Seikosha and Daini Seikosha, the latter being solely concerned with the design and manufacture of wrist watches. In 1962, the machine-tool interests of these two divisions were merged to form the Seiko-Seiki Co. Ltd. This new company developed various universal machine tools based on grinding machines. The principal products of Seiko-Seiki are internal and cylindrical grinders, linear transfer machines, rotary index machines, assembly machines, loaders and parts feeders.

3.11.2 Report

The visit was to the Takatsuka plant which manufactures mechanical watches, and the majority of the time was spent in the watch base-plate manufacturing shop. There were over a hundred precision machine tools, arranged in groups applicable to different watches, and all work-in-progress was transferred using chutes and bins. Over 100 vibratory bowl feeders and orienting devices were in use, and it appeared that these were all manufactured by Seiko-Seiki. A large number of small pick-and-place robots manufactured by Daini Seikosha (see section 3.11.3) were engaged in the transfer of parts from work station to work station. There was no evidence of any automatic assembly of watches at this plant, although a film of another plant in the division was shown in which the complete assembly of mechanical watches was achieved including the operations concerned with hairspring adjustment. It was claimed in the film that this highly-automated plant had been in operation for about seven years. The factory concerned is completely computer controlled, and palletized carriages with ferrite core edge readers for identification purposes are used.

3.11.3 Robot manufacture

Daini Seikosha Industrial Robots

Daini Seikosha manufacture a range of small relatively-unsophisticated robots. The Model-100 (see Fig.3.11.1) is a compact horizontal unit with two degrees of freedom, and is suitable for automatic assembly work on loads up to 1.5 kg (including the gripper): vertical stroke is 50mm, horizontal stroke is 200mm, repeatability is 0.01mm at a maximum cycle time of 2 seconds.

The Model-200 (see Fig.3.11.2) also has two degrees of freedom, and is suitable

for assembly work on loads up to 150g (including the gripper): vertical stroke is 20mm, and there is a swing of 90° or 120° about a vertical axis, repeatability is 0.01mm at a maximum cycle time of 1 second. Variants of this model include the 200W (with a dual arm to save transfer times during assembly), the 200-Z50 (with an increased vertical stroke of 50mm), and the 200C (with an intermediate stop in rotation for light-weight press working).

The Model 400 (see Fig.3.11.3) has a vertical stroke of 100mm, a horizontal stroke of 400mm, a payload of 4kg, repeatability of 0.025mm at a cycle time of 0.7 seconds: a 50mm shift gripper or a 180° rotation gripper can be fitted to the arm. A variant of this model, the 400L has an extended horizontal stroke of 700mm.

The Model 700 (see Fig.3.11.4) is similar to the 400-series but has an extra degree of freedom in swing through 90° to 120° about the vertical axis, although the payload is less, being only 0.5kg.

All the drives to the Daini Seikosha series are pneumatic at air pressures in the range 4 to 5 kg/cm². A variety of controllers, based on the Relay Controller Series RC-1, can be used to control the robots described in this section.

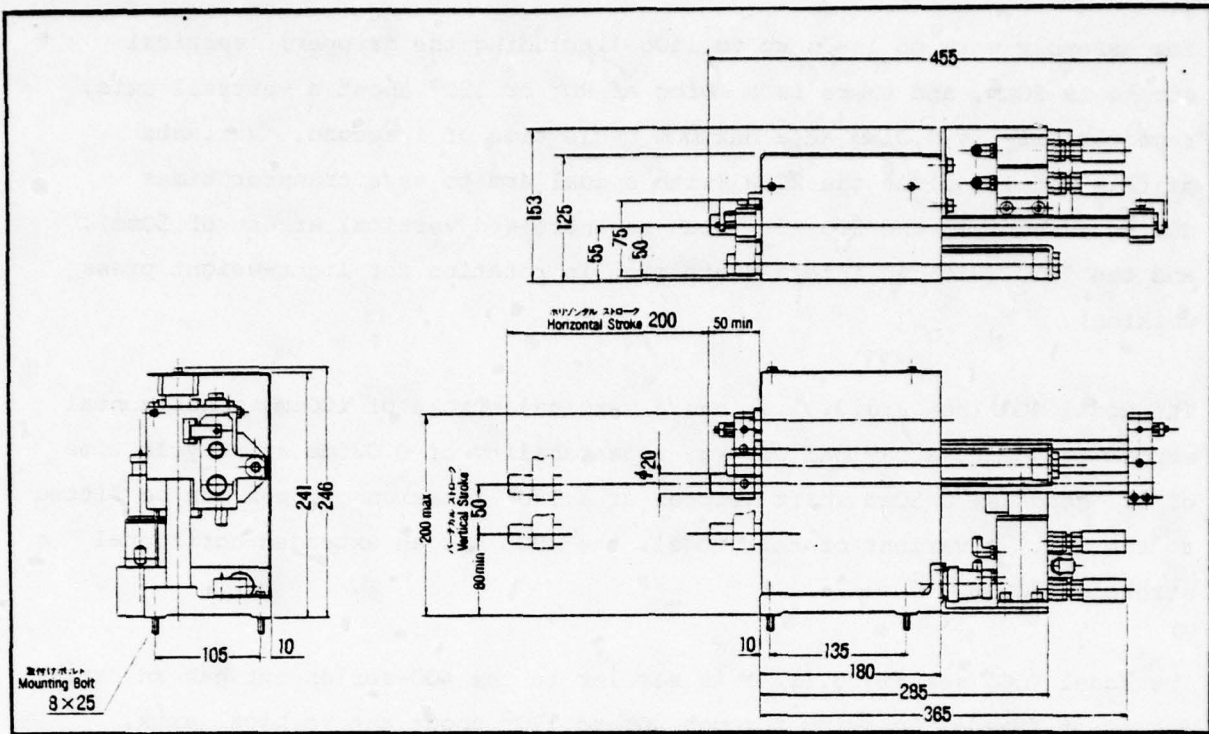

FIG. 3.11.1 DAINI SEIKOSHA MODEL 100

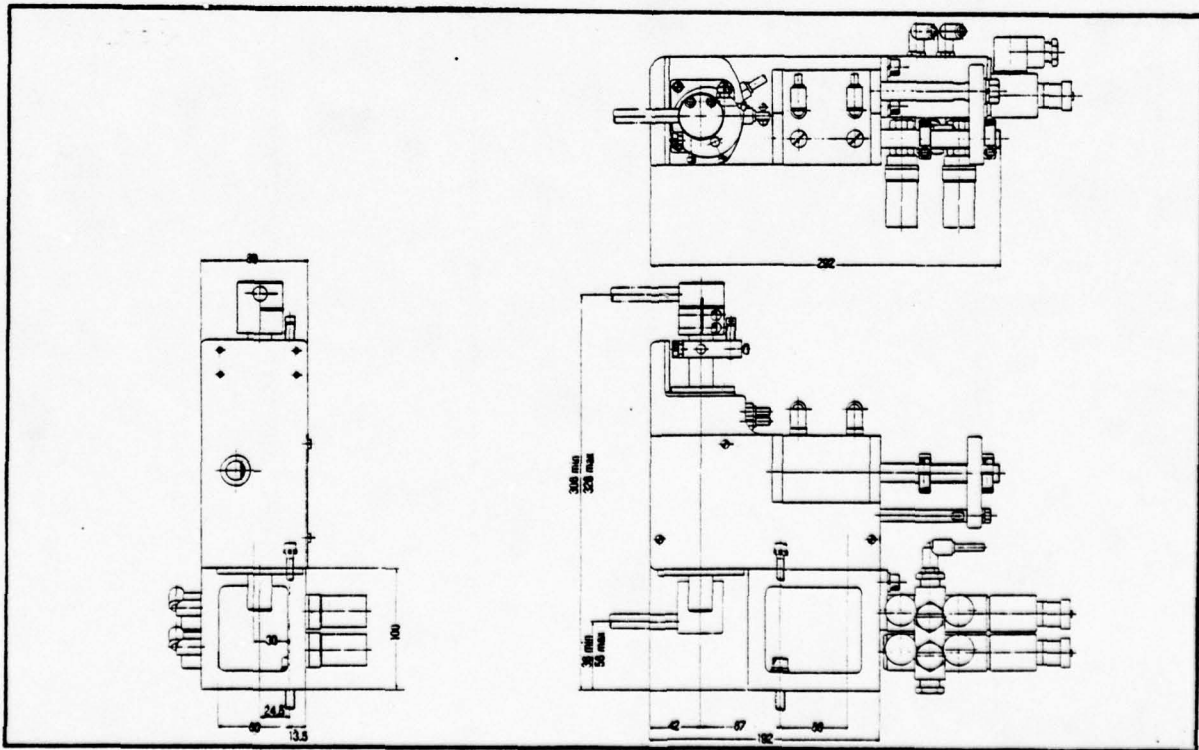

FIG. 3.11.2 DAINI SEIKOSHA MODEL 200

3.12 NAGASAKIYA COMPANY LTD.

3.12.1 Profile

Nagasakiya is one of Japan's leading chain stores and directly manages some 87 stores in the principal cities, although its main operations are centred in the Tokyo Metropolitan area. A wide variety of merchandise is sold with a special emphasis on clothing. In addition to operating stores on a direct management basis, the Company supplies franchise stores with Nagasakiya brands. In order to handle these franchise operations efficiently, a highly-automated Distribution Centre was set up in Tokyo and which can service up to 400 franchise stores. This centre incorporates a high-speed sorting machine which can handle up to 50,000 parcelled items per day.

3.12.3 Report

The visit was to the Nagasakiya Tokyo Distribution Centre, and attention was focussed on the high-speed sorting machine, which was regarded to be a robot by JIRA. The system was extremely simple in its design philosophy, and yet performed in an extremely impressive way. Before delivering goods to the Tokyo Distribution Centre, suppliers affix to the goods a special bar-coded label on which the vendor code is printed. The goods parcels come inward from lorries and are placed on a fairly slow conveyor which runs around the periphery of the building at high level. From the conveyor, the parcels are diverted onto two parallel 'sidings' each one being manned by one operator wearing a throat microphone and headphones. Movements of parcels along these sidings are controlled by a set of discrete conveyors in series: these enable the parcels to be stopped and queued as required. The operator reads out aloud the name of the store, which is then processed by a voice recognition system, and also orientates the parcel so that the bar-coded label is to the top. An overhead laser bar-code scanner reads the coded label, after which the control computer sends the vendor code and the cargo order number to an automatic printer/labeller which blows and fixes an appropriate gummed label to the parcel at the end of the siding. A rectangularly-shaped track circulates around the upper level of the warehouse, and a train of simple flat-bed wagons moves continuously at high-speed around it. The parcel is ejected from its siding onto one of these carriages, which then side tips automatically to deposit the parcel on to the correct chute for the appropriate lorry in the despatch bay. The system is fully integrated into the commercial activities of the company through a mini-computer network, and shipping statements, inventory documents and invoices,

for example, can all be printed in real-time.

The voice-encoding system is based on the Nippon Electric Co. Ltd. "Connected Speech Recognition System", which comprises an ADC Spectrum Analyser, a vocabulary reference memory, a dynamic programming processor, a classifier, an output interface processor and microprocessor. Output is in the form of the recognized word on a single-line display unit in front of the operator. Any words not recognized as being in the vocabulary result in a loud buzzing noise in the operator's headset. Each operator has his own vocabulary of up to 120 words stored on a personal floppy disc which he checks at the start of each shift. The bar-code reading laser scanners are in the Model OBR-70 series, also by Nippon Electric.

No real problems had been encountered with the system since its installation in March, 1979, and only 1 or 2 errors in 10,000 occurred in parcel identification.

3.13 TOSHIBA SEIKI CO. LTD.

3.13.1 Profile

The company was established as Toshiba Kiki Seizo Co. Ltd. in 1945 and assumed the current name in 1949. The paid-in capital in 1978 was 250 million yen at which time there were some 400 employees, the majority based at the Kanagawa site which was constructed in 1964. Principal products of the company include lamp and electron tube manufacturing machines, industrial machinery, vacuum pumps, linear-motion index units, rotary-motion index units, and industrial robots. There are two factories at Kanagawa: the main one has more than 100 machine tools including many NC tools and jig boring machines, the other one is an air-conditioned two-storey building in which high-precision products are manufactured.

3.13.2 Report

The visit was to the main Kanagawa plant which has always had a strong association with assembly equipment. Robot research commenced about ten years ago, but only in the past two years have they become a good business proposition. Four main robots are manufactured by Toshiba, (see section 3.13.3), the Tosman-200 for spot welding, the IX-12 and IX-15 for general-purpose manipulation, and the RHP and PBM Transer series for press working. All the current robots have point-to-point controls, although a continuous-path model for paint spraying is being developed. At present, the annual production of robots is 120 for press stamping, with 40 to 50 for car-body spot welding: about 30 of the Tosman 200 systems have been built to date. Production for this year is planned to be 200 robots and an increase of 50% is planned for next year. Costs are in the range 15 million yen for the IX series to 20 million yen for a Tosman 200 to control 20 axes. It was reported that there are no plans to develop robots for assembly work. There was a routine tour of the robot manufacturing areas, and a number of the IX and Transer series of robots were seen in various stages of construction and some of these were undergoing test exercises.

3.13.3 Robot manufacture

Toshiba Tosman-200

The Tosman-200 is a newly-developed multi-arm robot control system which was designed specifically for spot welding applications, particularly for the car industry. It comprises two principal components: the control system and the robot mechanism (see Fig.3.13.1). The control system is capable of handling up to 10 robots using point-to-point positioning. Memory capacity is 320

program points which gives a range of 320 points in a single-robot single-program configuration to 16 points in a ten-robot two-program configuration. Up to 20 axes can be controlled simultaneously.

The robot mechanism has a combination of degrees of freedom selected from two linear motions (each with optional ranges of 200/400/600mm at rates up to 60mm/sec) and one angular motion in swing of 60° at up to 20°/sec. Since it is not generally economical to use a high-performance robot with five or six degrees-of-freedom in a sub- or final-assembly process for spot welding, it is considered that the Tosman 200 provides an effective and economical solution for automobile spot welding. Synchronization and interlocking signals are provided so that the system can be easily interfaced to the associated automation devices.

Toshiba Industrial Robot Tosman

The Toshiba Tosman robot is similar in general layout to that of the Unimate. There are two basic models, the IX-15 with six degrees-of-freedom (see Fig. 3.13.2) and the IX-12 with five degrees-of-freedom (see Fig. 3.13.3). Both machines are suitable for moulding, die-casting, welding, and the loading and unloading of machine tools.

The fundamental motion of the 6-axis IX-15 comprises arm in-out (900mm at 700mm/sec), arm up-down ($\pm 30^\circ$ at 30°/sec), arm swing (220° at 90°/sec), wrist bend (220° at 90°/sec), arm twist (360° at 90°/sec). The maximum load of 35 kg can be positioned under point-to-point control to an accuracy of 1mm with a memory capacity of 500 points. For synchronization purposes, eight interlock signals are provided (4 in, 4 out).

In contrast, the small 5-axis IX-12 robot has a fundamental motion comprising arm in-out (700mm at 700mm/sec), arm up-down ($\pm 30^\circ$ at 30°/sec), arm swing (220° at 90°/sec), wrist bend (220° at 90°/sec), wrist rotate (220° at 90°/sec) and a wrist clamping motion (on-off). The standard load is 15 kg which can also be positioned to an accuracy of 1mm using point-to-point control. Unlike the IX-15, the IX-12 does not have wrist twist but has several more interlocks (10 in, 6 out) and a palletizing control function.

Both robots are equipped with timers to control the time between moves, and conditional branch instructions can be inserted into the normal sequence of commands to give different routes through a program. Programming is done by teach-in/playback, and a magnetic tape cassette and linear continuous-path

interpolation can be added as options.

Toshiba Industrial Robot Transer

The Transer range of robots is especially suited to stamping-press working and has two basic models: the RBM series which execute vertical and swinging movements and the RHP series which carry out vertical and sliding movements. Neither series is programmable, and both are operated using cam-drive mechanisms manufactured by Toshiba.

In the RHP series, a twin-face cam track controls linear movements (see Fig.3.13.4). Vertical pick-and-place stroke is either 20mm or 40mm, and the horizontal sliding movement is either 200mm or 400mm. A load of up to 0.7 kg can be transported from station to station at a cycle time of 2 seconds.

In the RBM series, a barrel cam controls the vertical pick-and-place stroke (either 20, 40, or 60mm) and a face cam controls rotary transfer angles (60-120°) - see Fig.3.13.5. There are three basic variations in this series, and all can be equipped with arm-stretching, jaw-rotating, jaw or vacuum heads. A load of up to 3 kg can be transported at a cycle time of 3 seconds.

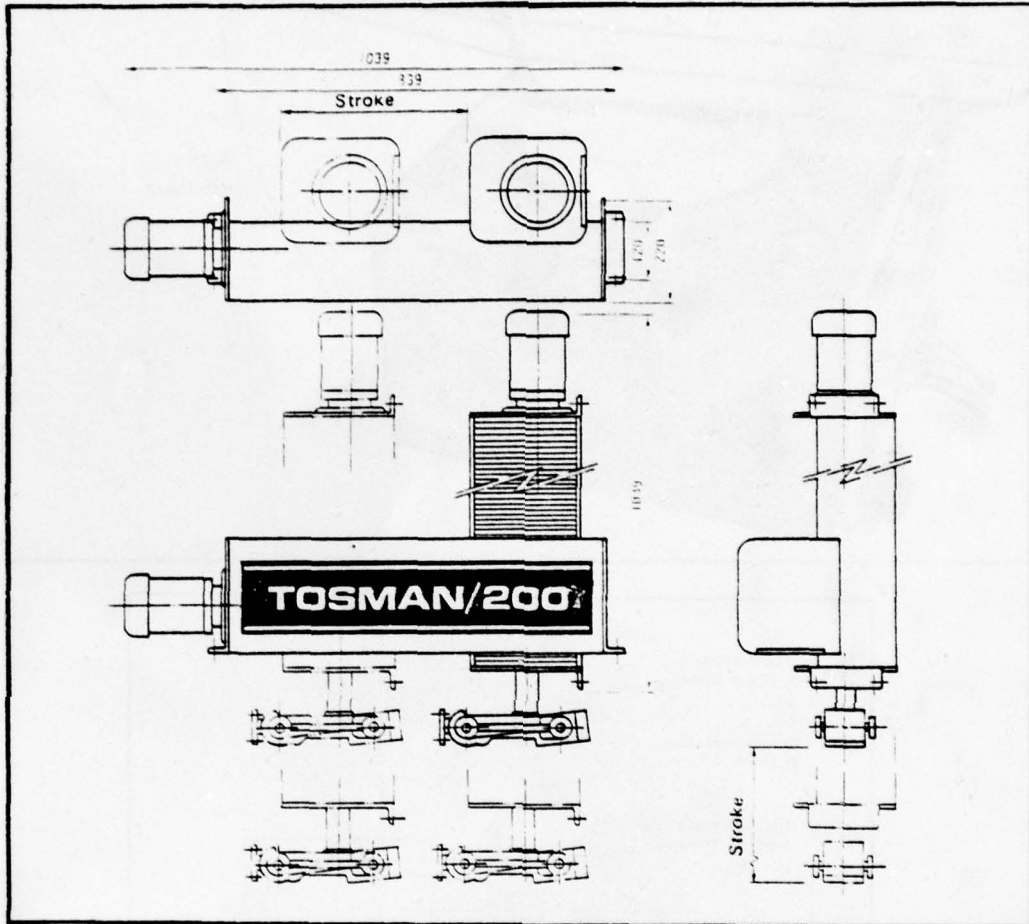

FIG. 3.13.1 TOSMAN 200 ROBOT

● TYPE IX-15 (6 AXES)

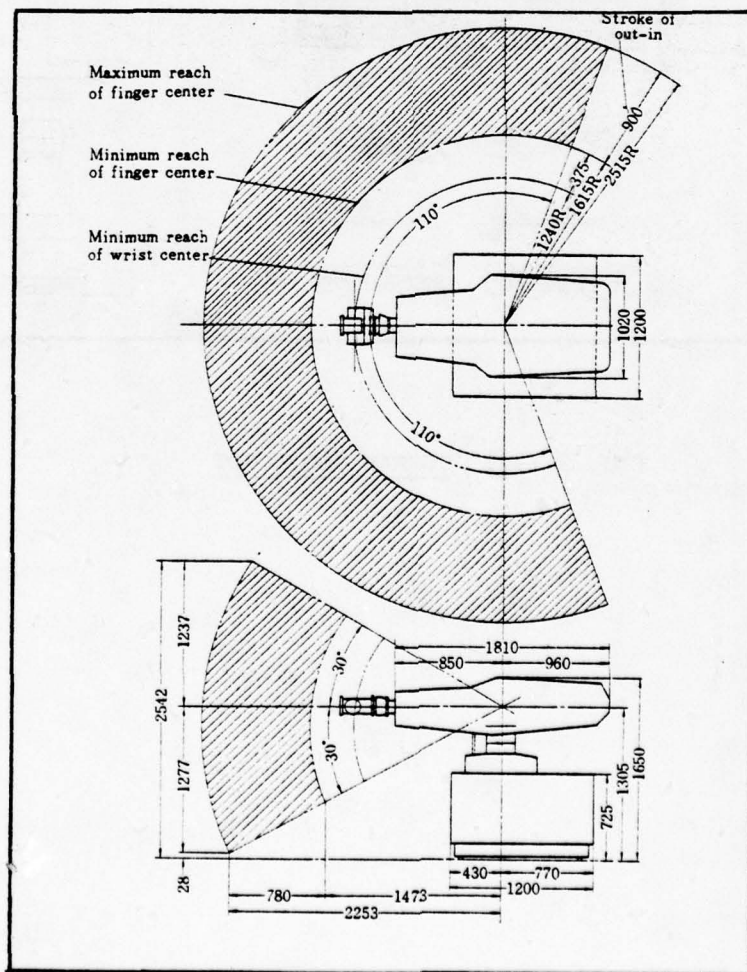
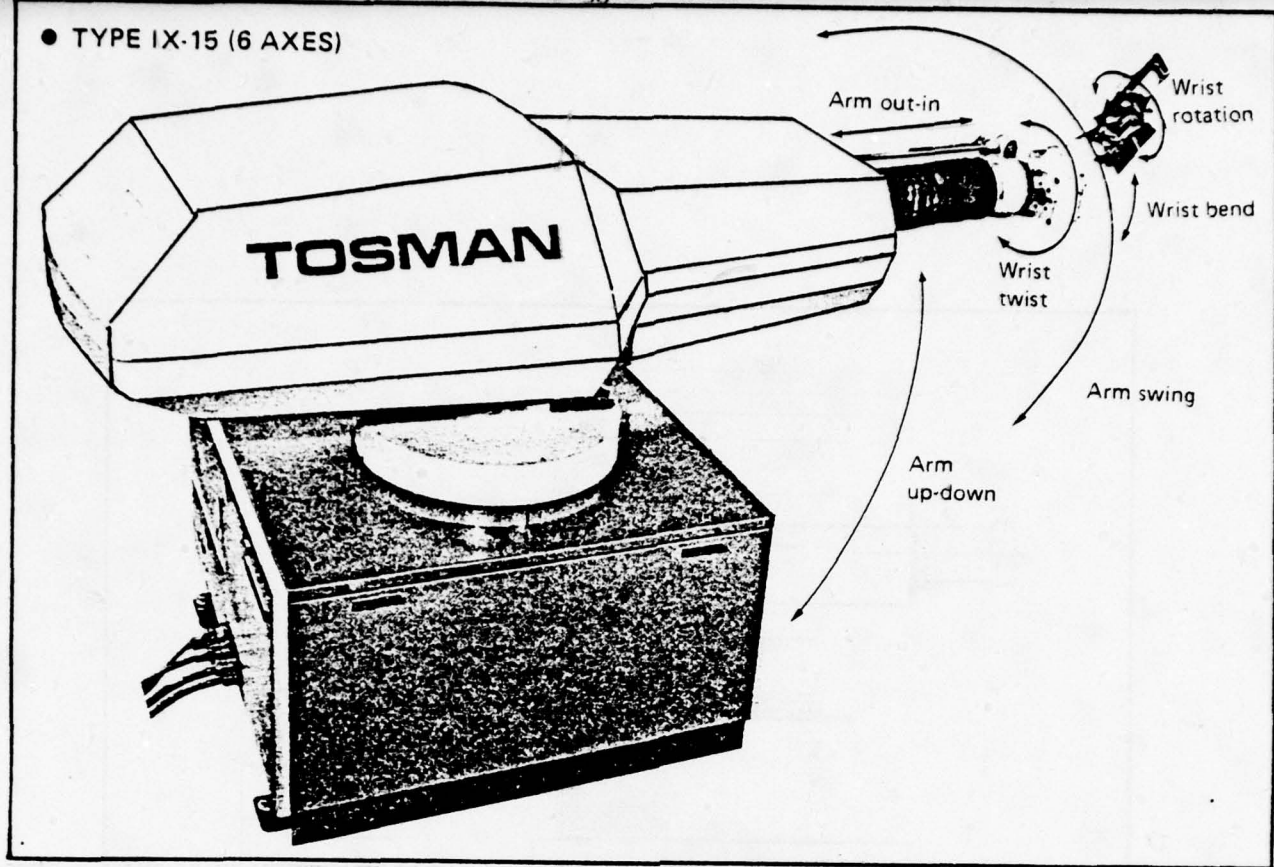

FIG. 3.13.2 TOSMAN IX-15 ROBOT

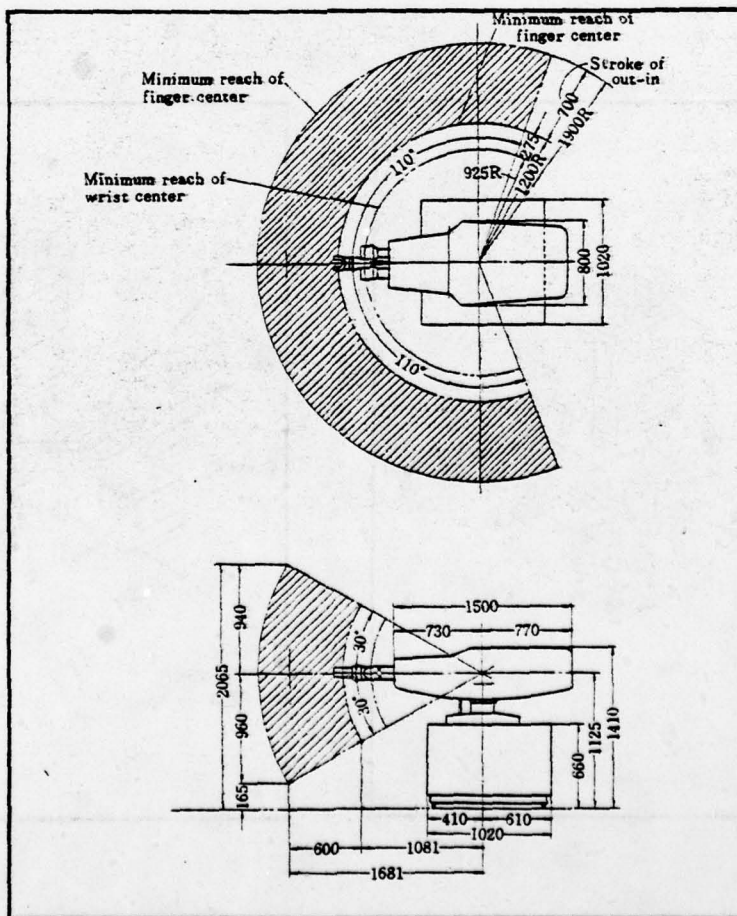
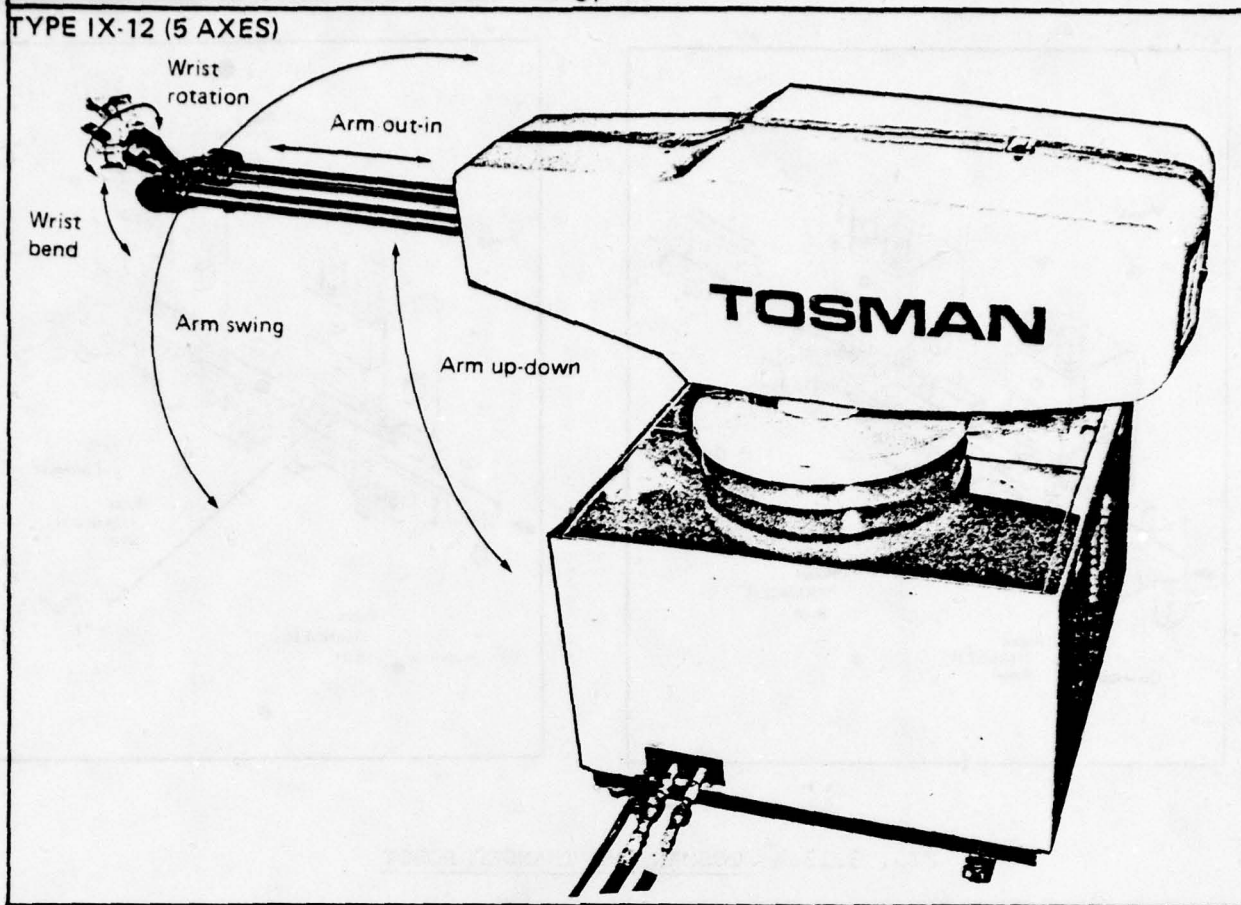

FIG. 3.13.3 TOSMAN IX-12 ROBOT

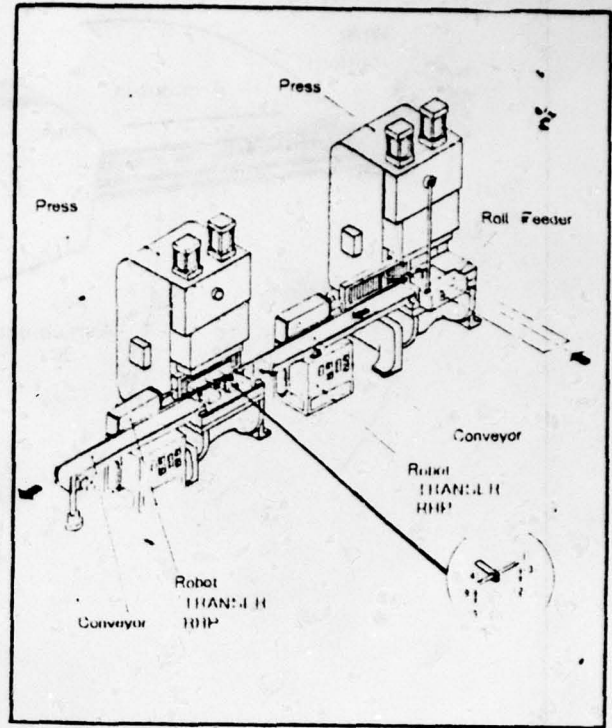
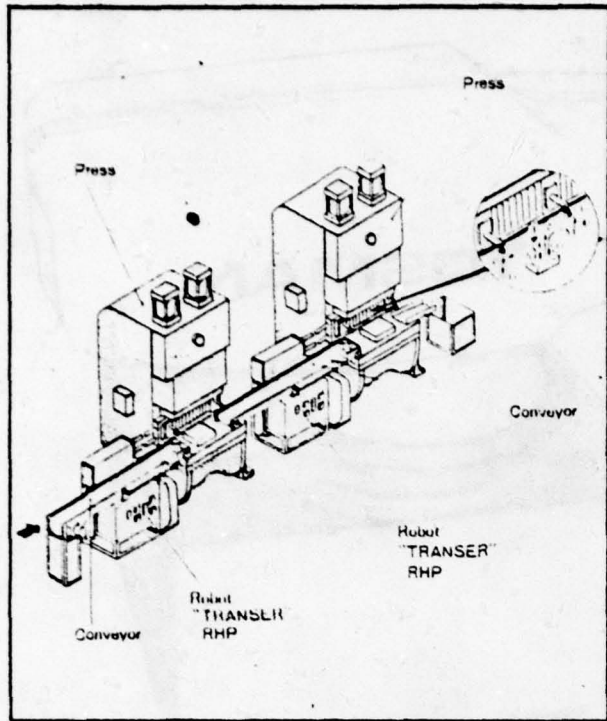

FIG. 3.13.4 TOSMAN RHP TRANSER ROBOT

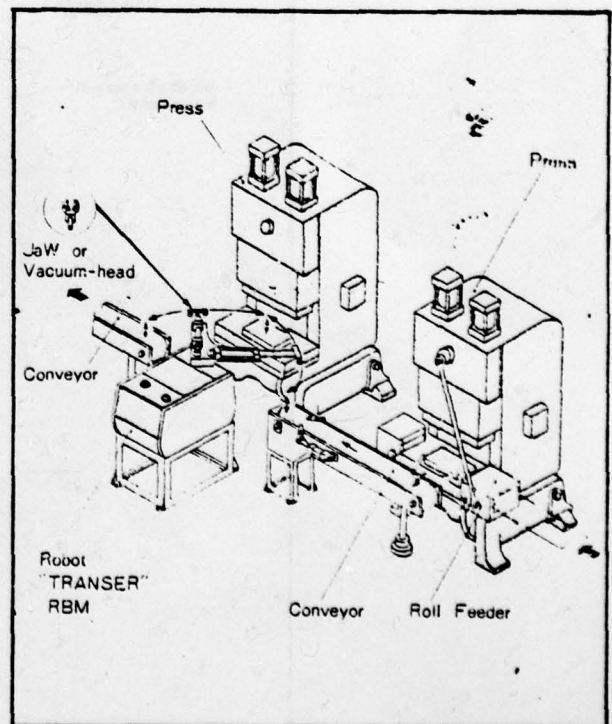
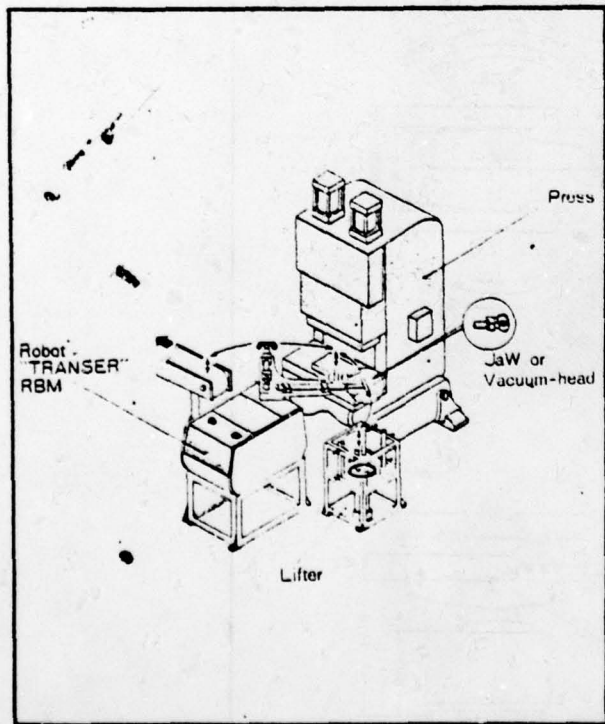

FIG. 3.13.5 TOSMAN RBM TRANSER ROBOT

3.14 JAPANESE MARINE SCIENCE AND TECHNOLOGY CENTRE

3.14.1 Profile

This centre was set up in 1971 under the Japan Marine Science and Technology Centre Act to raise further the level of this technology by implementing integrated research and development projects, by constructing and managing large-sized testing facilities, for training, and for collecting and disseminating information on marine science and technology. In 1979, the staff amounted to 119 and the current annual budget is 4.6 billion yen. The centre is organized into eight departments of which the Marine Development Technology Department was of principal interest.

3.14.2 Report

The only robot developed at the centre is a so-called Underwater Bilateral Servo Manipulator which can be used for underwater drilling, sawing, grinding, welding and power-wrench work. It was developed during a three-year research programme which commenced in 1973. The robot comprises a 'machine hand', a 'man hand', a controller and a monitor TV and would normally be mounted on an underwater vehicle. The 'machine-hand' is a mechanical slave arm (roughly in human form) connected electrically to a harness worn by the operator, and which mimics the motion of the master arm. Force feedback to the human arm is very accurately maintained up to a maximum load of 10kg. Two arms are implemented on the device on which all joints can be locked, if required. Only two of these devices have been manufactured, and it appeared that neither have been used recently due to a lack of funding.

4.0 CONCLUSIONS

Japan's first industrial robot was developed in 1967, some five years after the first industrial robot was used in the U.S.A. Later, however, Japan's industrial robots have made spectacular progress both in terms of technology and applicability: thus, Japan has come to play a leading role in the field of industrial robots throughout the world. There are about 120 industrial robot manufacturers in Japan while there are only 30 to 40 manufacturers in Europe and the U.S. The number of industrial robots now in operation in Japan is approximately 30 thousand units, with probably no more than 3,000 units in Europe and the U.S. Also in Japan, universities and government as well as public research institutions are carrying out extensive research and development projects for industrial robots in an extremely directed fashion. In this connection, about 300 researchers at around 70 research institutes conducted R & D projects at an annual expenditure of approximately 400 million yen in 1977.

Figures 4.1 and 4.2 show changes in Japan's production of industrial robots both in terms of quantity and value. From these figures, it can be seen that Japan's industrial robot industry has achieved a steady growth year by year. Industrial robot production was reduced temporarily in 1971 due to the nation's economic recession. Later on, however, despite the 1973 oil crisis and the subsequent economic slowdown, it has continued to show a steady upward tendency, though it became stagnant in 1975. Such a steady production increase has been brought about by efforts to improve productivity to cope with increasing production costs as well as to prevent industrial accidents and occupational diseases caused by work under unfavourable conditions. Toward this end, a large amount of money has been invested in the automatisisation of production, with the emphasis on introducing industrial robots. Industrial robot production is expected to increase according to the long-term demand forecast made by the JIRA in 1975, and shown in Figure 4.2. This long-term demand forecast covered the manufacturing sector only and does not include such sectors as nuclear energy, ocean exploitation, medicare, civil engineering, and social welfare. These sectors are expected, however, to use an increasing number of industrial robots in the future.

The production of industrial robots by category and the actual supply to industrial users is shown in Figures 4.3 and 4.4 respectively. Although research and development projects for intelligent robots are conducted

actively, their actual production still remains negligible. Since an attempt is being made to automate multi-product and small batch production, particularly the assembly process, in order to improve productivity, it is expected that intelligent robots will be put into practical operation in the early 1980s. There will be a sharp increase in the production of intelligent robots in 1980. The share of intelligent robots in the total output of industrial robots is expected to reach 5 percent in 1980 and 15 percent in 1985.

As shown in Figure 4.4, the automobile industry is the biggest industrial user of industrial robots, accounting for more than 30 percent of the total demand. In this sector, industrial robots are used in such processes as welding, press working, plastic moulding, component assembly, and treatment. Following the automobile industry come such sectors as electric machinery, plastic moulding products, precision machinery and metal products. The electric machinery manufacturing industry uses industrial robots chiefly in the processes of press working assembly, machining, plastic moulding, and plating. Industrial robots are used by the precision machinery industry mainly in the processes of machining, press working, assembly and die casting. The metal products manufacturing industry uses them chiefly in the press working and cutting processes. There are other industrial sectors where there will be sharp increase in demand in the not-too-distant future. These sectors include the iron and steel industry and the bicycles and industrial vehicles industries. The iron and steel industry utilises industrial robots in the melting, blooming, inspection and shipment processes. The bicycles and industrial vehicles industry use them in the press working, welding and painting processes.

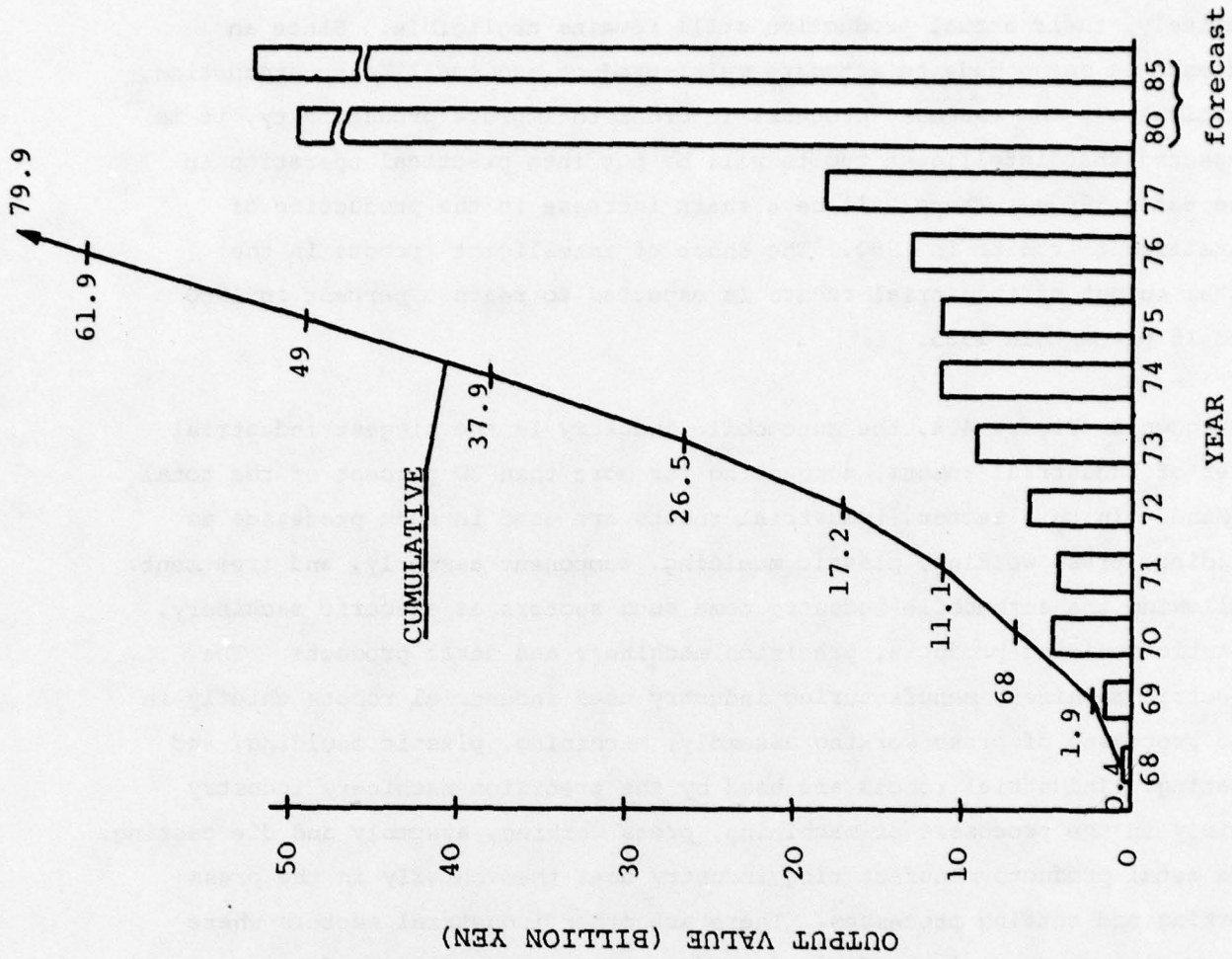

FIG. 4.2 PRODUCTION OF ROBOTS BY VALUE

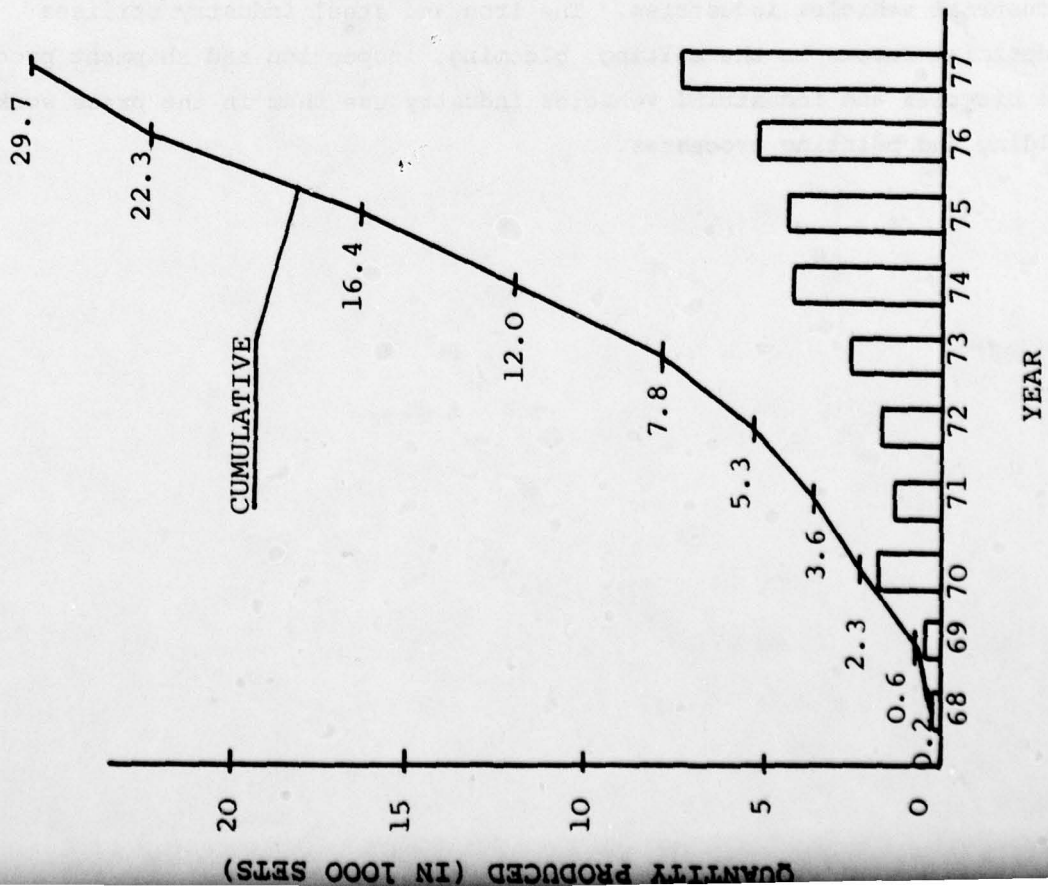

FIG. 4.1 PRODUCTION OF ROBOTS BY NUMBER

- A manual manipulators
- B robots with fixed (B1) or variable (B2) sequence control
- C playback robots
- D NC robots
- E intelligent robots

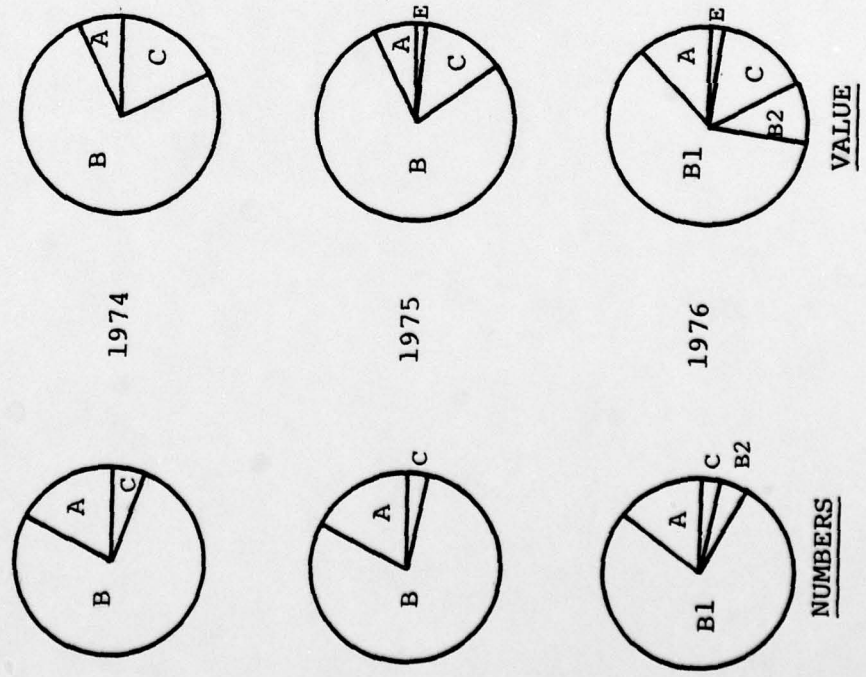

FIG. 4.3 PRODUCTION OF ROBOTS BY TYPE (1974-1976)

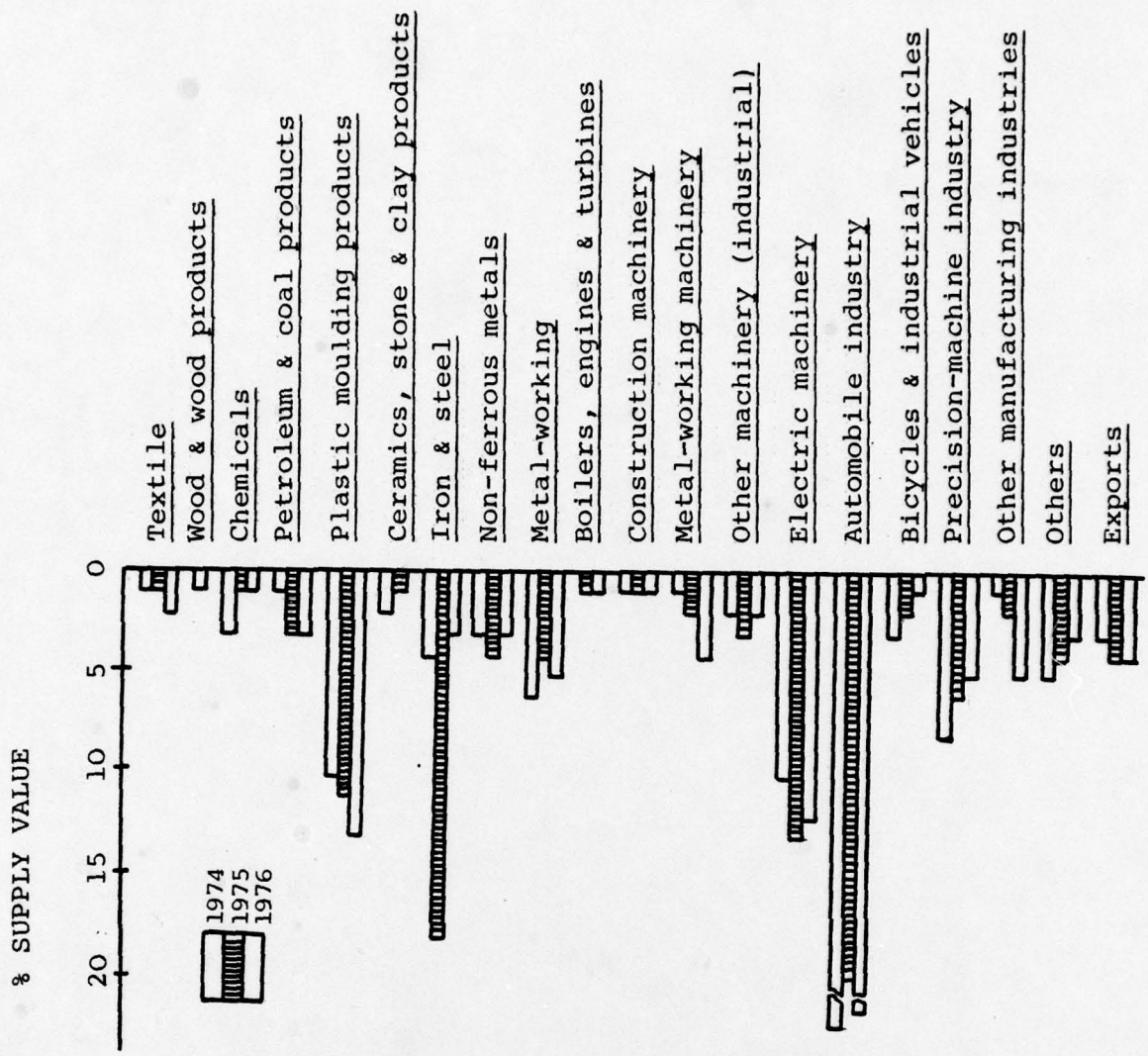

FIG. 4.4 INDUSTRIAL DISTRIBUTION OF ROBOTS (1974-1976)

APPENDIX 1 : JIRA MEMBERSHIP LIST

Aida Engineering Ltd. 2-10, Oyama-cho Sagamihara, 229	Press processing
Daido Steel Co., Ltd. 11-18 Nishiki 1-chome Naka-ku Nagoya 460.	Casting processing, die-casting, forging, glass handling, electrode connection assembly, press processing, carbide furnace, felting.
Daikin Kogyo Co., Ltd. Shin-Hankyu Bldg. 1-12-39, Umeda Kita-ku Osaka 530	Arc welding, machining processing, spray painting.
Daini Seikosha Co., Ltd. 4-3-1, Yashiki Narashino 275	Material-handling of small work pieces, assembly press processing.
Dainichi Kiko Co., Ltd Daini Maruzen Bldg., 6-16-13, Nishi-Shinjuku Shinjuku-ku Tokyo 160.	Palletizing, heavy-duty handling, tool change.
Fuji Electric Co., Ltd. Shin-Yurakucho Bldg., 1-12-1, Yurakucho Chiyoda-ku Tokyo 100	Machining processing, press processing.
Nachi-Fujikoshi Corp. World Trade Centre Bldg., 2-4-1, Hamamatsucho Minato-ku Tokyo 105.	Spot-welding, arc-welding, spray painting, press processing, heavy-duty handling, carbide furnace.
Fujitsu Fanuc Co., Ltd. 3-5-1, Asahigaoka, Hino, Tokyo 191.	Material handling, tool change, machining processing.
Hirata Industrial Machineries Co. Ltd. 5-4, Myotaijicho, Kumamoto 860	Assembling, machining processing.
Hitachi, Ltd. Shin-Maru Bldg., 1-5-1, Marunouchi Chiyoda-ku, Tokyo 100	Arc-welding, spray painting, assembly, material-handling.

Ichikoh Industries Ltd. 5-10-18, Higashi-Gotanda Shinagawa-ku Tokyo 141	Plastic moulding.
Ishikawajima-Harima Heavy Industries Co. Ltd. 3-5-1, Mukodaicho Tanashi Tokyo 188	Material handling of heavy work.
Kanzaki Kokyu Koki Mfg. Co., Ltd. 341 Inadera Amagasaki 661	Press processing.
Kawasaki Heavy Industries, Ltd. World Trade Centre Bldg., 2-4-1, Hamamatsucho Minato-ku Tokyo 105.	Spot-welding, arc-welding spray painting, palletizing, material handling, diecasting processing.
Kayaba Industry Co., Ltd. World Trade Centre Bldg., 2-4-1, Hamamatsucho Minato-ku Tokyo 105	Machining processing, palletizing, heavy-duty handling.
Keiaisha Mfg., Ltd. 4840 Izumicho Totsuka-ku Yokohama 244	Diecasting processing, press processing.
Kobe Steel, Ltd. 1-3-18, Wakinocho Fukiai-ku Kobe 651.	Spray painting, arc-welding, marking processing.
Komatsu, Ltd. 2-3-6, Akasaka Minato-ku Tokyo 107	Forging processing, palletizing, heavy-duty handling.
Mitsubishi Electric Corp. 2-2-3, Marunouchi Chiyoda-ku Tokyo 100	Washing, IC's and transistors bonding, processing.
Mitsubishi Heavy Industries, Ltd. 2-5-1, Marunouchi Chiyoda-ku, Tokyo 100.	Spot-welding, spray painting, machine process, diecasting processing.
Motoda Electronics Co. Ltd. 4-32, Kamikitazawa Setagaya-ku Tokyo 156	Material handling heavy-duty handling.
NagoyaKiko Co. Ltd. 180 Higashi Ohkutecho Toyoake 470-11.	Material-handling, die-casting, forging processing.

Nippon Electric Co., Ltd.
1753 Shimonumabe,
Nakahara-ku,
Kawasaki 210

Voice recognition systems,
NC controllers.

NTN Toyo Bearing Co. Ltd.
1-3-17, Kyomachibori
Nishi-ku
Osaka 550

Light-material handling,
press processing, assembly.

Oki Electric Industries Co., Ltd.
1-7-12 Toranomom
Minato-ku
Tokyo 105

NC controller.

Sanki Engineering Co., Ltd.
Sanshin Bldg.,
1-4-1 Yurakucho,
Chiyoda-ku
Tokyo 100.

Material-handling.

Shinko Electric Co., Ltd.
Asahi Bldg.,
3-12-2, Nihonbashi,
Chuo-ku
Tokyo 103.

Press processing,
die-casting processing,
heat-treatment processing.

Shinmeiwa Industry Co., Ltd.
1-1, Shinmeiwacho
Takarazuka 665

Arc-welding.

Showa Kuatsuki Co., Ltd.
1010 Minorudai
Matsudo 271

Die-casting, plastic moulding,
press processing.

Star Seiki Co., Ltd.
2-36, Shimosakacho
Mizuho-ku
Nagoya 467

Plastic - moulding.

Taiyo, Ltd.
48, Kita-Eguchicho
Higashi-Yodogawa-ku
Osaka 533

Machine processing.

Tokiko, Ltd.
Kasahara Bldg.,
1-6-10 Uchikanda
Chiyoda-ku
Tokyo 101

Spray painting.

Tokyo Keiki Co., Ltd.
2-16, Minami-Kamata
Ohta-ku
Tokyo 144

Tokyo Shibaura Electric Co., Ltd.
3-13-12, Mita
Minato-ku
Tokyo 108

Toshiba Seiki Co., Ltd.
5-14-33, Higashi-Kashiwagaya
Ebina 243.

Toyoda Machine Works Ltd.
1-1 Asahicho
Kariya 448

Tsubakimoto Chain Co.
4-17-88, Tsurumi
Tsurumi-ku
Osaka 538

Tsubakimoto Machinery & Engineering Co., Ltd.
Kokusai Kanko Kaikan Bldg.,
1-8-3, Marunouchi
Chiyoda-ku
Tokyo 100.

Yasukawa Electric Mfg. Co., Ltd.
Ohtemachi Bldg.,
1-6-1, Ohtemachi,
Chiyoda-ku
Tokyo 100.

Spot-welding, press processing,
arc welding, machine processing.

Machine processing,
spot welding.

Material-handling.

Arc-welding, machine processing,
assembling process.

APPENDIX 2: ADDRESSES OF COMPANIES VISITED

1: a.m., 29 May 1979

Mr. Kohei Ito, Managing Director, Manager Engineering Administration Department
Fujitsu Fanuc Ltd.
5-1 Asahigaoka 3-chome
Hino-shi
Tokyo 191

2: p.m., 29 May 1979

Mr Ryo Fukumoto, General Manager, Manufacturing Department No.2
Mr. Minoru Doi, General Manager, Production Control and Engineering Department
Nissan Motor Co. Ltd.
1-1 Banchi Enoki
Musashi Murayama-shi
Tokyo

3: a.m., 31 May 1979

Mr. K. Seko, Senior Manager of Engineering Staff, Hydraulic Machinery Division
Kawasaki Heavy Industries Ltd.
Nishi-Kobe Works
234 Matsumoto-Hazetani-cho
Tarumi-ku
Kobe
Akashi Works
1-1 Kawasaki-cho
Akashi

4: p.m., 31 May 1979

Mr. Masakuni Yamaguchi, Assistant General Manager, Machinery and Equipment Group
Kobe Steel Ltd.
3-18, 1-chome, Wakino-hama-cho
Fukiai-ku
Kobe

5: a.m., 1 June 1979

Mr. T. Miyao, Manager, Export Department
Shin Meiwa Industry Company Ltd.
1-1, Shinmeiwa-cho
Takarazuka-shi
Hyogo-ken

6: p.m., 1 June 1979

Mr Kohjiro Makita, Factory Manager, Kyde Works
Mitsubishi Electric Corporation
Kyoto Works
1 Zusho Baba
Nagaokakyo City
Kyoto

7: a.m., 4 June 1979

Mr. Toyotaro Yamada, General Manager, Public and Community Relations,
Toyota Motor Company Ltd.
Aichi-ken
Toyota-shi, 471

8: p.m., 4 June 1979

Mr Kazuhide Naruki, General Manager, Manufacturing Development and Production
Engineering Department
Nippondenso Company Ltd.
1-1 Showa-cho
Kariya-shi
Aichi-Ken, 448

9: a.m., 5 June 1979

Mr. Shigetaka Morimoto, Vice General Manager,
Mitsubishi Motors Corporation
Nagoya Motor Vehicle Works
Okazaki Plant
1 Nakashingiri, Hasime-cho
Okazaki Aichi Prefecture, 444

10: p.m., 5 June 1979

Mr. Toshio Kato, Deputy General Manager, Manufacturing Department,
Manager, Quality Control Section
Fuji Electric Company Ltd.
Mie Plant
No. 1-27 Fuji-cho
Yokkaichi-City
Mie Prefecture

11: p.m., 6 June 1979

Mr. Shigeru Iwai, Manager, Industrial Electronics Division
Daini Seikosha Company Ltd
Kameido Factory
13-1 Kameido 6-chome
Koto-ku
Tokyo

12: a.m., 7 June 1979

Mr Tsutomu Abe, General Manager
Kanda Transportation Company Ltd
Nagasakiya Tokyo Distribution Centre
3-5, 1 chome, Ariake,
Koto-ku
Tokyo

Also representing Nippon Electric Company at Nagasakiya:
Mr. Rinzou Ebukuro, Deputy Manager, Engineering, Machine Control Systems,
Engineering Department
Industrial Automation Division
Nippon Electric Company Ltd.,
10, 1-chome, Nissin-cho,
Fuchu City
Tokyo 183

13: a.m./p.m., 7 June 1979

Mr. Masanobu Narita, President
Toshiba Seiki Company Ltd.
14-33, 5 chome, Higashikashiwayaya
Ebina-shi
Kanagawa-wen

14: p.m., 7 June 1979

Mr. Murata, Manager, General Affairs Department
Japan Marine Science and Technology Centre
Natsushima
Yokosuka 237