

AD-A077 180

ROYAL AIRCRAFT ESTABLISHMENT FARNBOROUGH (ENGLAND)

F/G 20/4

A HEAVY DUTY BALANCE CALIBRATION MACHINE FOR THE RAE 5M LOW SPE--ETC(U)

APR 79 E C BROWN

UNCLASSIFIED

RAE-TR-79039

DRIC-BR-69045

NL

| OF |
ADA
077180

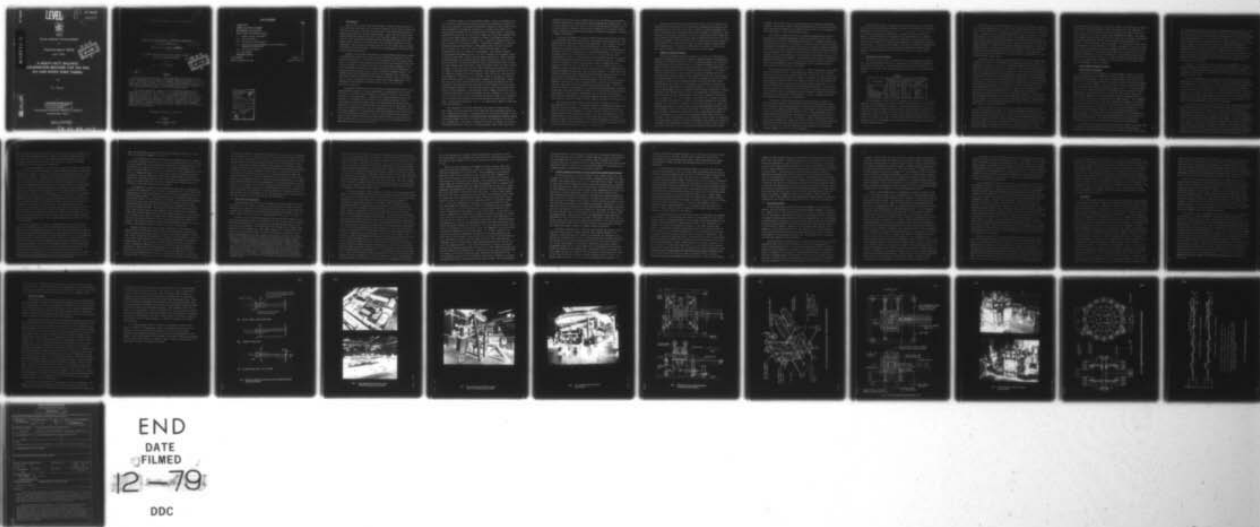

END
DATE
FILMED
12-79
DDC

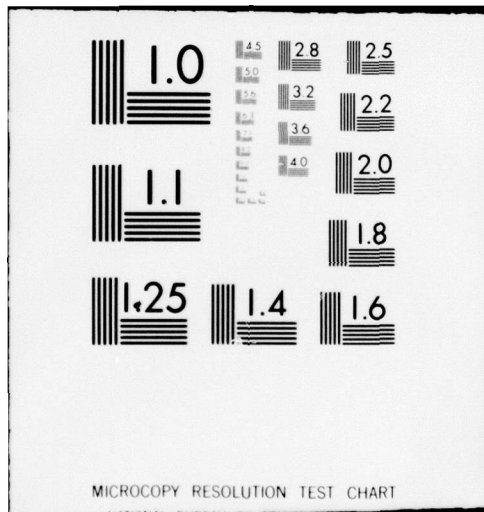

TR 79039

UNLIMITED
LEVEL

①

TR 79039

BR69045

SC



ROYAL AIRCRAFT ESTABLISHMENT

*

Technical Report 79039

April 1979

DDC
NOV 26 1979
REGISTRY
E

AD A 077180

**A HEAVY DUTY BALANCE
CALIBRATION MACHINE FOR THE RAE
5m LOW SPEED WIND TUNNEL**

by

E.C. Brown

*

This document has been approved
for public release and sale; its
distribution is unlimited.

Procurement Executive, Ministry of Defence
Farnborough, Hants

DDC FILE COPY

UNLIMITED

79 11 09 012

1

14 RAE-TR-79039

ROYAL AIRCRAFT ESTABLISHMENT

9 Technical Report, 79039

12 43

Received for printing 2 April 1979

11

6 A HEAVY DUTY BALANCE CALIBRATION MACHINE FOR THE RAE 5m LOW SPEED WIND TUNNEL.

by

10 E. C. Brown

DDC
RECEIVED
NOV 26 1979
RAE

18 DRIC 19 BR-69045
SUMMARY

The 5m low speed wind tunnel at RAE Farnborough will make use of a wide variety of balances for measuring the aerodynamic loads on the models to be tested in it. These will include internal and external strain gauge balances for complete and half model testing, as well as a mechanical lever balance which can cope with tests on both forms of model. Maximum model normal forces will approach 130 kN in half model testing and up to 90 kN on complete models.

This Report reviews the background to the calibration problem and then describes the development of the design of a calibration machine which is sufficiently versatile to cope with all of the foreseeable types of balances which will be used in the tunnel. The loading system of this machine is based on pneumatically-powered force generators controlled by a computer, and these are capable of generating any combination of loads in response to an input demand originating from a manually operated switchboard or from a stored programme. A typical 400 point calibration occupies less than 12 machine hours of testing with one operator in attendance.

Departmental Reference: Aero 3452

Copyright

Controller HMSO London
1979

310 450

LIST OF CONTENTS

	<u>Page</u>
1 INTRODUCTION	3
2 GENERAL CALIBRATION PROBLEMS	6
3 THE EXISTING RAE FACILITIES	8
4 THE 5m TUNNEL CALIBRATION MACHINE	10
4.1 Design concept development	10
4.2 Force generators	13
4.3 The balance loading system	16
4.4 Balance mounting arrangements and the deflection compensating mechanisms	19
4.5 The control systems	21
4.6 Performance	24
5 CONCLUDING REMARKS	28
Illustrations	Figures 1-12
Report documentation page	inside back cover

Accession For	
NTIS GRA&I	<input checked="" type="checkbox"/>
DDC TAB	<input type="checkbox"/>
Unannounced	<input type="checkbox"/>
Justification	
By _____	
Distribution/ _____	
Availability Codes	
Dist	Avail and/or special
A	

1 INTRODUCTION

From its very earliest days the aerodynamic testing of aircraft models in wind tunnels has been beset with a number of problems, not the least of which has been the limitations on the size and performance of the facilities themselves, brought about mainly by economic considerations. Apart from the purely aerodynamic difficulties which are entailed in testing small models at low air speeds, there are also considerable problems with the instrumentation due to the very modest surface pressures, and hence model forces, which are generated in these conditions. The net result has always been for the wind tunnel staffs to demand the highest possible standards of accuracy and discrimination in their force and pressure measuring apparatus.

Designers were already under pressure to design balances which were capable of resolving the total load on a model - which was usually suspended a metre or so below the balance on a wire rig - into its principal force and moment components. In addition it was required that each output from the balance should give a true indication of the value of the load in its particular component of the total load which was virtually free from interactions from other components. By making the balance into what was in effect a mechanical analogue computer, the designer effectively eliminated the need for the computing staff to make the interaction calculations which are now accepted as routine. Had it been otherwise of course, the problem could quite easily have become unmanageable as all computing was then manually executed and aided only by slide rule and mathematical tables etc.

The balances which were evolved were special purpose machines and of a very high standard in terms of accuracy, sensitivity and repeatability etc and they required to be calibrated with equipment of sufficient calibre to ensure that this was so. The whole range of expertise thus created reached its peak in the mid-1950s and culminated in the design of the measuring system for the 8ft tunnel balance calibration machine, whose sole purpose was the certification of the internal strain gauge balances which were then required by that tunnel. This machine was designed and built under the guiding genius of G.F. Midwood who had also been responsible for the design of every other mechanical lever balance then in use in Aerodynamics Department at RAE. The specification for the measuring system of this machine allowed typical non-linearity errors of only one part in 5000 of maximum load with similarly stringent curbs on the interferences between components and other important parameters.

The modern concept of the strain gauge balance, which is now common in low speed as well as high speed wind tunnel testing, was an essential by-product of the surge of interest in supersonic aerodynamics witnessed in this country in the period immediately following the 1939-45 war. In tunnel tests models can be mounted on wall balances but the principal method of model support is one which approaches the model from the rear (ie the sting rig) and the most commonly used form of strain gauge balance is therefore one which is interposed between the forward end of this sting and the model, and is completely contained within the model envelope (ie the internal balance). Designs were prepared for a number of mechanical balances incorporating a sting support system, and one is known to have been built for a 9in x 9in (23cm x 23cm) supersonic tunnel at RAE Farnborough but little is known of its performance. Both forms of balance, ie strain gauge and mechanical lever, are used to measure the aerodynamic forces on models in wind tunnel testing and need precise calibration. However whereas, barring accidents, the mechanical balance needs calibrating only once, and this should suffice for its normal working life span of perhaps thirty years or more, its strain gauged relative may need a check calibration before each major session of usage. In the early days this was a major consideration particularly so as the science of precision force measurement by strain gauge techniques was then in its infancy and sensitivity was at a premium. This resulted in a proliferation in the numbers of balances built for each wind tunnel as attempts were made to achieve the best results by matching balance designs to expected model loading. Each and every balance needed calibration, and although one suspects that the precision of this operation often fell short of that achieved for the low speed tunnel mechanical balances, it nevertheless involved much time-consuming effort and not a little apparatus. Each supersonic tunnel somehow contrived to equip itself with some form of balance calibration rig and, although the sophistication of these installations varied widely between the various tunnels, it is probably fair to say that the calibration facilities kept pace with the balance performance, for the early strain gauge balances were comparatively simple in design and modest in performance.

The building of the RAE 8ft supersonic wind tunnel had repercussions in many fields of related activities, one of which was that concerning balances and their calibration facilities. In keeping with the outlook and confidence of the era, a semi-automatic balance calibration machine incorporating a powered loading system was designed and built for the 8ft tunnel. This machine was successful and, although slow in operation, represented an impressive advance over previous calibration procedures. The 3ft x 4ft high supersonic speed wind tunnel which

followed a few years later was equipped with a much less ambitious calibration machine incorporating a simple manually-operated deadweight loading system. Both the above machines were built primarily for calibrating internal balances, but it is also possible to calibrate those balances designed for use with wall mounted models, although the available loading ranges are generally inadequate to provide a complete calibration.

The latest development in the wind tunnel balance scene, and the one which is of particular concern in this Report, is concerned with the building of a new pressurized low speed wind tunnel at RAE Farnborough - the 5m tunnel. The combined effects of model size, wind speed and pressure in this facility are expected to yield model normal forces in the region of 90 kN for complete models and nearly 130 kN for half models; the rolling moment generated in a balance by the latter load will be of the order of 140 kN m. To meet this and other requirements the tunnel is being equipped with a mechanical balance, a sting rig for strain gauge balance work and a balance calibration machine of a form which renders it suitable for calibrating the whole range of balances which are expected to find their way into this facility. Clearly balance loads of the magnitude referred to above must present an entirely new set of conditions to be met in the design and operation of the calibration machine. At these loads, the traditional methods of force generation by gravitational means can only be justified in the most exceptional circumstances, eg in the establishment and maintenance of the standards of force measurement. The cost of such an exercise adapted to the needs of a multi-component balance would be quite unacceptable even when judged in terms of time and manpower involvement alone. There was therefore an obvious requirement for a power-operated loading system, preferably acting under some form of automatic control, or at least one involving the minimum of operator intervention. Additionally, and in spite of its formidable specification requirements, the calibration machine was required to be built at a cost which was acceptable within the tight budgetary controls of the 5m project.

This Report describes a machine which has been designed to meet the requirements outlined above. It has been designed to be completely automatic in operation, under the control of a computer, and its actual estimated cost, as defined in the contract documents, is within a few per cent of that of the 8ft tunnel machine of some fifteen years earlier. In order to achieve this, it has been necessary to accept compromises which involve some loss of performance relative to that of the 8ft machine. It is however confidently believed that the accuracy of the forces and moments generated in this machine will except in rare cases be better than $\pm 0.05\%$ of full scale balance loads.

The major part of this Report was written in early 1973; it describes the background to the 5m problem and the design and development work leading to the integration of the first basic ideas into a practical working arrangement from which a contractor could develop his final detailed design. Unfortunately a combination of circumstances conspired to delay its publication and the machine has passed from the first tentative design stage to the physical actuality, and in so doing has (September 1977) achieved one of its design objectives by successfully calibrating its first strain gauge balance for the 5m tunnel in approximately twelve working hours. The Report has therefore been revised to include some extra material which is relevant to the machine as it now exists.

2 GENERAL CALIBRATION PROBLEMS

In order to calibrate any force balance it is first of all necessary to establish a loading system which is capable of applying loads of the appropriate magnitude to the required accuracy, and in the precise positions and directions required relative to the balance axes. For a typical mechanical wind tunnel balance this is not particularly difficult in theory, as such machines have axes which are fixed relative to those of the wind tunnel structure. In such cases all that is necessary is to set a number of pulleys and loading cables with scale pans into a precise pattern, and to connect the cables to a rigid calibration frame attached to the balance. The cables can normally be made relatively long and the errors in their alignments which result from the small elastic deformations in the balance due to loading are not sufficient to degrade the accuracy of the calibration by an unacceptable amount. In the practical case however, any loading action by deadweight methods demands an apparently excessive attention to the detailed design of all of the components of the apparatus in order to achieve the very high standards of accuracy, sensitivity and repeatability in this work. It is, for example, quite normal for a mechanical balance in a low speed wind tunnel to be capable of resolving increments of load whose magnitude is of the order of 0.002% of its full scale load and to be capable of repeating measurements of applied loads with maximum differences between successive readings of two or three times this amount. Such capabilities demand very high standards of design and construction of the loading apparatus which, it must be remembered, may be required to accommodate single loads in excess of 10 tonnes. Under such conditions the loading cables can no longer be regarded as being particularly flexible, and the pivot bearings of the pulleys and levers are far removed from conventional laboratory knife-edge bearings. Many different designs have been tested for this application including multiple knife edge

bearings, flexure pivots and more recently gas and oil lubricated hydrostatic bearings. The generally smaller angular displacements of the balance structure under load makes it possible to use simple flexure pivots at the attachments for the loading cables to the balance loading frame.

As a typical example of the sort of unexpected complications arising in this work, it is perhaps interesting to note that detectable errors can be generated even in such a simple application as that of a stranded cable passing round the rim of a pulley. As the load in the cable is varied, the wires extend and compact the strands, and unless this process is completely uniform throughout the whole arc of contact between the cable and the pulley, (and friction between the wires themselves and between the cable and the pulley ensures that it is not) then the result is the production of an effectively variable-ratio lever in an apparently symmetrical arrangement. These effects can be minimised by making the pulley of large diameter, but it is now more usual for them also to have wide flat rims to accommodate a band of high tensile steel of minimum thickness inserted into the cable length at this point.

For the strain gauge balance, there are a number of additional difficulties which arise because its axes of measurement are defined relative to its model end, and in the case of the internal balance the calibration loads are reacted to earth through the sting to which the balance is attached. The whole balance and sting assembly deflects as the load is applied and this causes the balance axes to be displaced relative to those of the (fixed) loading system (Fig 1). In order to restore the situation to its normal unloaded condition it is therefore necessary to move the 'earthed' end of the sting by the amounts shown in Fig 1c and, as these or similar adjustments have to be applied in respect of deflections occurring in the three planes of measurement, it will be appreciated that the actions involved may become quite complicated.

In addition to these purely geometrical problems there is always one further and most practical difficulty which merits some consideration, namely that of actually lifting and applying the calibration masses which are required to be moved in a typical loading exercise. This problem has been briefly mentioned in the introduction to this Report, but it is most improbable that an average reader can have any real appreciation of its magnitude when related to balances in the 5m tunnel class. For example, a single loading action of the normal force component of a typical half model balance to its maximum design load would entail the application and removal from the scale pan of no less than 1.8 m^3 of cast iron. There are many such actions required in a calibration although, happily, not all are of this magnitude.

From these few examples of typical problems in this work, it will perhaps be more easily appreciated that although the basic overall problem is by no means complicated, the actual implementation of the actions required to solve it may well involve an apparently disproportionate amount of effort, expertise and expense. Unfortunately very few laboratories are sufficiently well endowed to make it possible to maintain a continuing development of the necessary skills, and very few designers ever experience the opportunity to design even one machine in this class. Just how two such designers tackled their particular problems can be seen in Figs 2 and 3 which show the two major calibration machines at RAE Bedford; brief descriptions of these machines are given in section 3 which follows.

3 THE EXISTING RAE FACILITIES

The two major wind tunnels at RAE Bedford are each equipped with purpose-built calibration machines which are representative of two different approaches to the same basic problem. Before attempting to describe these machines it is instructive to tabulate their loading ranges alongside those of the 5m mechanical balance.

Table 1

Force/moment	5m tunnel mechanical balance	8ft tunnel calibration machine	3ft x 4ft tunnel calibration machine
Lift (Z)	±90 kN	±33 kN	-2.9 kN +11 kN
Drag (X)	±22 kN	±13 kN	±1.8 kN
Side force (Y)	±127 kN	±13 kN	±2.5 kN
Pitching moment (m)	±15 kN m	±10 kN m	±850 N m
Rolling moment (l)	±140 kN m	±10 kN m	±480 N m
Yawing moment (n)	±40 kN m	±4 kN m	±290 N m

The 5m mechanical balance, Fig 4, is designed to be capable of testing both complete and half models, and it is this latter case which gives rise to the high side force and rolling moment loadings. To offset these effects and to allow increased accuracy in complete model testing at low wind speeds, the three moment systems have dual load ranges such that on light range the above values are reduced by a factor of 5. The sensitivity of measurement remains at one part in 25000 of the chosen load range. The 8ft tunnel calibration machine also has dual ranges but on all six components, the light range values being equal to one third of those quoted in Table 1.

Of the above two calibration machines, that in the 8 ft tunnel is undoubtedly the more impressive both in terms of the vision displayed in its concept and in its overall performance. The general arrangement of this facility is shown in Fig 2. It consists of a six component mechanical balance surrounded by a loading frame coupled to a hydraulic loading system. The mechanical balance is of a virtual centre type in which the straight line and spherical motions required in the force and moment resolving system occur between air lubricated surfaces. The compound bedplate to which the strain gauge balance mounting block is seen to be attached (Fig 2) was originally intended to accommodate a cradle for supporting the model at the coincident centres of the two balances. The strain gauge balance would then be calibrated whilst in the model and on the sting to be used in the subsequent tunnel tests.

The object of this proposed procedure was to avoid any loss of calibration integrity resulting from the breaking and re-making of the various joints. In practice the balance is loaded via a sting which connects at its outer end with a rigid frame surrounding the calibration balance. This ring frame has a number of hydraulic bellows (force generators) coupled to it by flexibly jointed push-pull rods; the component forces are then generated in the bellows by the application of hydraulic pressure from variable height water tanks visible in the background of Fig 2. The objective of the design was the production of a system which would self balance to any preset loading condition as specified by the operation of the calibration balance controls. In practice it was found that stability of the servo-balancing system could not be achieved unless it was operated much more slowly than was originally envisaged due to a combination of mechanical hysteresis and hydraulic lag in the force generators themselves. The settling time following each change in the loading condition varies with the magnitude of the load change and with the particular bellows being activated. The performance is improved by a skilled operator manually controlling the servo drives in the final stages of any load application.

The second machine, ie that in the 3ft x 4ft high speed wind tunnel at Bedford is included as an example of a typical arrangement resulting from the use of a gravity controlled loading system. Reference to Fig 3 will show that it consists in part of a braced A-frame trestle structure supporting duplicated sets of levers disposed about three mutually perpendicular axes. The levers are connected by pivoted links to a loading frame to which the balance is attached, and their free ends are equipped with carriers to which the operator can apply calibrated masses in accordance with the loading requirements. All of the lever

pivots and other hinged points in the loading system of this machine are composed of knife-edge bearings arranged in single or compound axis form depending on their duty. (NB Fig 3 shows only the calibration machine, which did not have a balance mounted in it at the time when this photograph was taken.) The second main assembly of this machine consists of a calibration sting which is mounted in trunnions incorporated in the two sets of compound slides mounted on the pedestals in the background of the illustration. The deflections of the balance and sting under load are cancelled by the manual adjustment of a number of screw jacks acting on the slide and trunnion mountings, but as in the case of the 8 ft tunnel machine these control actions need considerable operator skill for their successful completion. A faulty interpretation of the balance position error indicators can quite easily lead to the wrong 'correcting' action being applied and it is not unknown for a balance to be overloaded to the extent that it was physically damaged in such a situation.

4 THE 5m TUNNEL CALIBRATION MACHINE

4.1 Design concept development

Although not actively involved in the development of either of the above machines, the author was nevertheless very well acquainted with them and their operating characteristics - a most useful attribute when trying to assess the suitability of the techniques employed for projection into the conditions applicable to the 5m tunnel machine. As a result of this, and of earlier involvement in balance calibration work, two things were quite clear viz (1) that the magnitude of the next generation balance loads demanded the use of powered loading techniques for calibration work, and (2) that the units involved should have 'stand alone' capabilities to dispense with the need for subsequent checks on their outputs (such as was the case in the 8ft tunnel machine). This recognised the fact that not only would it have been prohibitively expensive to duplicate the 8 ft idea but also, like that machine, the 5m machine would then have been restricted to working on a fixed site. This itself was unacceptable as it was required that the 5m machine should also be used in conjunction with the mechanical balance as a direct check on the performances of both machines under those conditions, the mechanical balance having previously been calibrated by a deadweight loading system. The machine had therefore to be portable and sufficiently versatile to cope with both internal and external balances.

The proposed total reliance on the force generator concept, and on the long term integrity of their control systems was by then receiving considerable encouragement from some promising results which were being recorded during tests

on a prototype pneumatically powered unit of approximately 50 kN output. It was also noted with relief, that the response rate of this system was much higher than was the case for the 8ft tunnel force generators, but even so it was decided, as a design objective, to try to design the 5m machine so that each force and moment component of the load was generated by a single dedicated force generator. This philosophy was also extended to include the deflection compensating mechanisms which are required to maintain the positioning and alignment of the balance axes with respect to those of the loading system to compensate for balance and sting deflections under load. These were required to operate in such a way that single axis movement should wherever possible, result from a single control action, and this should involve the minimum cross coupling effects between the various controls.

Finally it was decided to design each part of the machine, eg loading system dimensions and alignments etc to guarantee the integrity of its contribution to the overall accuracy of the machine to 0.01%; the accuracy of the calibration loads applied to a typical balance was required to be within 0.05% of balance full scale load.

The above requirements were embodied in a brief specification which was presented to T & E Designs Ltd as the ground rules of a design study which they were commissioned to undertake. This firm was chosen for the task mainly because of the fact that all of the members of its staff have considerable practical experience of wind tunnel testing and were familiar with the problems which are peculiar to the design of wind tunnel strain gauge balances and their calibration. Throughout the exercise which followed, the firm worked in close collaboration with RAE, and the major contribution which they made to the development of the design of the present machine is gratefully acknowledged.

In the course of this design study much effort was concentrated on developing designs for the wide variety of sub-assemblies which constitute the whole, and the requirements and limitations of the various forms of balances were investigated in some detail. It was this latter aspect of the work which highlighted the profound effect on the design of the machine of its need to adapt to the several requirements of the different balance types. In order to cope with all of these, it had to have some degree of mobility, and mobility - even in the very restricted sense required - implied compactness. The dispersed loading system of the form described for mechanical balances was quite unsuitable as it inevitably resulted in a large unwieldy earth frame of sufficiently substantial proportions to react the calibration loads at various distant points on its

circumference. Additionally there were the special needs of the balance mounting arrangements and of the deflection-compensating mechanisms to be considered, and it was a combination of these and other effects which eventually resulted in the development of the much simplified loading assembly illustrated in Fig 5. The very compact nature of this arrangement seriously complicated the problems involved in designing the compensating mechanisms needed to fulfil the requirement for dedicated force generators on each balance force and moment component (Fig 6). Further work demonstrated that these problems could be overcome but it was reluctantly concluded that the ensuing arrangements would have been very difficult and costly to make and assemble to the required standards of accuracy. They were therefore abandoned in favour of the arrangement illustrated in which each axis arm of the loading tree has two force generators acting on it in such a way that their outputs are summed to produce a force and applied in opposition to produce a moment.

The general arrangement of the machine was then (1972) of the form shown in Fig 5 and it was at this point that the design study was discontinued. The main reason for this decision was to be found in the tenders for the design and manufacture of the mechanical balance, which included a deadweight calibration system capable of the full loading range calibration of the balance to the required standards of accuracy. The sums included in the tenders for calibration were considerably in excess of earlier estimates, a situation which doubtless reflected the difficulties which were anticipated in designing and installing the apparatus itself, coupled with the massive task of loading it by manual effort. As a result of this it was decided that the mechanical balance should, as far as possible, also be calibrated by means of the calibration machine, and the balance specification was rewritten to incorporate the necessary modifications and additions. This final specification included the provision of a deadweight calibration system capable of loading the mechanical balance to a minimum of 20% of the load range in each of its six components. The load level specified for this part of the calibration was determined by the need for an accurate determination of the balance interactions. Loads in excess of the above figure were to be applied by a combination of the calibration machine and deadweight loading so that the whole calibration could, in effect, be completed (in stages) by deadweight loading. This was not exactly an ideal arrangement, but it did seem to be adequate bearing in mind the circumstances which gave rise to it and the fact that it was intended to calibrate the force generators and their control equipment as complete systems against the Deadweight Standard Calibration Machines at NPL before attempting the above task.

The contract for the design and manufacture of both the mechanical balance and the balance calibration machine was finally awarded to TEM Engineering Ltd early in 1973 and completed late in 1978. As has already been noted in section 1 the calibration machine was completed earlier and was in fact used to calibrate its first strain gauge balance in September 1977. Figs 7 and 8 show the general arrangement of this machine and it will be noted that it differs from that shown in Fig 5 mostly by virtue of the simplification of the arrangement of the linkage motions which support the loading system. The original intention to split these into two separate assemblies dealing with the angular and translational displacements of the loading system respectively has been abandoned and replaced by a single system consisting of three vertical and three horizontal links only. Each of these links is a motor-driven variable-length screw jack, and by electrically gearing their drive motors it is possible to arrange them to generate the whole range of displacements required to maintain the alignment of the axes of the loading system and the balance.

4.2 Force generators

Reference has already been made in the preceding paragraphs to the use of force generators, and it now seems timely to expand on these before passing on to the description of the complete calibration machine. In the context of this Report, force generators are devices which generate a single force in response to a fluid pressure input, as typified by a simple piston and cylinder arrangement. For various reasons, such as the effects of friction between the moving parts and the inadequacies of the then existing pressure measuring and control equipment, the use of this concept in calibration work has in the past been limited to those situations in which it was possible to measure the actual output of the device to the required accuracy. This was normally achieved by incorporating a precision load cell into the loading system or, in the admittedly rather extreme case of the 8ft tunnel calibration machine, by using a complex mechanical balance to measure the summed outputs from a number of coupled force generators.

The emergence in the early 1960s of a completely new range of high precision pressure gauges, and a little later by their fully compatible pressure control units, made it possible to consider the feasibility of developing a range of pneumatically-powered force generators to replace the deadweight loading methods which were normally used in balance calibration work. The need for such a development had been apparent for a long time and it was given added impetus and urgency by the early forecasts of typical model loadings expected in the 5m tunnel. As a result, it was decided to investigate the performance of some

possible designs of units which could be suitable for work on 5m balances, and to this end some force generators and a simple test rig were designed and built in the latter part of 1970. A full description of this equipment, and of the development testing for which it was used, appears in a separate Technical Memorandum now being prepared for publication.

The general arrangement of a typical force generator is shown in Fig 9 from which it will be seen that it embodies a double ended piston which for mechanical convenience is normally attached to the fixed load reacting structure via its two projecting extremities. A spindle is inserted into the piston and its ends project to form the guides on which the outer casing (cylinder) can slide in an axial direction, the friction between the two parts being limited by the inclusion of recirculating-ball linear bearings. The gaps between the pistons and the cylinder are sealed by simple synthetic-fabric-reinforced rubber diaphragms* which are specially formed and fabricated to allow relative motion between the piston and the cylinder to be accommodated by a rolling action of the diaphragm material in the gap between them. The diaphragms can be made of a relatively lightweight flexible material as the only loads which they are required to sustain are those generated by the pressure loading on that part of them which is unsupported by the piston or cylinder wall. This gap is typically 6.3 mm (0.25 inch) wide and hence the total load on the diaphragms in this area of the unit illustrated is of the order of 15% of the total. The resulting stress in the fabric reinforcing material is only about 4.5 N/mm or 25 lbf/inch due to the fact that this total load is shared in the two walls of the U shaped formation of the diaphragm at this point. (The assumed maximum working pressure is 1.4 MPa or 200 lbf/inch².)

The unit illustrated is capable of generating an axial force in either direction by the admission of gas at a controlled pressure through one or the other of the drilled passages leading to the two ends of the piston, the accuracy of the force so generated depending largely on the qualities of the measuring and control instruments. Those chosen for this application are the Texas Instruments Fuzed Quartz Bourdon Tube Precision Pressure Gauge and the Precision Pressure Controller developed by the same company; they are capable of measuring and controlling gas pressures with accuracies approaching those of the best laboratory standard devices and yet even so are suitable for general laboratory use. Provided that the working pressure is not allowed to exceed about 2 MPa the discrimination and repeatability of this combination is equivalent to, or better

* The Bellofram rolling diaphragm is used for this application.

than, that which may be expected of the better mechanical balances ie of the order of one part in 100000 of full scale.

Force generators of the type illustrated are naturally subject to temperature effects on their effective piston areas and although these are quite small in normal terms, they are of considerable significance in calibration work. If we consider cast iron as the normal material for their construction, we can expect the force output at constant inlet pressure to vary by approximately 0.01% for a 5 K temperature change, or about 0.03% for normal variations in ambient conditions. Each force generator on the calibration machine is therefore provided with a temperature sensing element whose output is measured by the control computer at each loading point and used in computing the pressure required to satisfy the demand for a particular force output.

The standard of accuracy actually achieved by these units is perhaps best illustrated by referring to Fig 10 which is a reproduction of a calibration chart belonging to the 20 kN force generator reference letter A-A included in the calibration machine inventory. This particular chart is of interest inasmuch as it contains the results of three separate calibrations. Two of these were performed in the NPL 5 tonne force standard machine with an interval of about 6 weeks between them whilst the third partial calibration was performed on the NPL 50 tonne force standard machine. The chart also includes three extra data points which relate to the results of some comparative tests made on the two machines by NPL staff using an unspecified calibration standard test piece. These results are presented in the form of a pressure error plotted against the applied force, where the error is the difference between the calculated pressure required to generate a particular force and the actual measured pressure, expressed as a percentage of the pressure required to achieve full scale force output.

Although reference has been made only to the type of force generator as supplied with the calibration machine, there are other possible variants which differ from the present design only in the type of piston seal employed. One of these (which has not been investigated in relation to the 5m machine) is based on a novel form of seal pioneered by the Ferrofluidics Corporation of Burlington, Massachusetts, USA. This particular sealing technique has been developed and tested in commercial applications over the past few years and is principally designed as a shaft seal for rotating machinery such as pumps and compressors. Whatever the form of the actual configuration, each seal consists of a ring magnet and pole blocks which form part of a magnetic circuit that is completed by the shaft (Fig 11). The pole pieces have shaped grooves machined in them (which

are similar to those of a conventional labyrinth seal) and the seal is completed by the introduction of a magnetic fluid into the annulus between the pole pieces and the shaft. The magnetic field present in the gap forces the liquid to form what are in the effect liquid O-rings between the labyrinth elements and the shaft. The pressure-sustaining capability then depends on the number of these O-rings in the seal, as each will typically sustain a small pressure differential of between 20 and 30 kPa, although a single stage seal has been successfully tested to about four times the above value. Seals have been built which are suitable for working at a pressure differential of 4.2 MPa which is three times as great as the working pressure of the 5m calibration machine units; the largest shaft diameter known to have been accommodated is 300 mm which equals the piston diameter of the largest force generator supplied with this machine. The arrival of the first information on this new sealing technique practically coincided with the decision point on the design of force generator to be provided for the present machine, and the development work on force generators, which would then have been more relevant to future applications, was discontinued.

4.3 The balance loading system

This particular part of the overall design of the machine cannot fail to be controversial in one respect or another, for not only does it demand the almost unconditional acceptance of the force generator concept, but it also incorporates a rather unusual solution to the problem of maintaining the alignment of the axes of the loading system with those of a balance which deflects as it is loaded.

Reference to Figs 7 and 8 will show that the balance (here assumed to be an internal strain gauge balance) is attached at its rear (sting) end to a short and very stiff sting mounted on a table sliding in machined guides attached to the earth frame of the machine. The forward end of the balance has an adaptor which connects it to the loading tree. This member consists of a large casting in the form of a three dimensional cross, ie it has three mutually perpendicular arms loosely corresponding to the three balance axes* (Fig 6). Each of the loading

* Since it is neither possible nor desirable to define for all time a unique configuration for the alignment of the axes of all of the balances which will be tested in this machine, it has been decided to define the machine axes and to relate its force and moment capabilities to those axes. Thus the machine's X axis is the horizontal axis of the loading tree arm on the projection of the sting axis, its Z axis is vertical and intersects the X axis at the loading centre of the machine and its Y axis is horizontal and also intersects the other two at the loading centre. The moments appropriate to this arrangement are defined as M_x , M_y and M_z . To avoid confusion metal plates bearing suitably descriptive legends are attached to the machine in prominent positions on the loading system.

tree arms has a total of four very accurately positioned location holes bored into it as indicated in Fig 6, and these are used to locate the ends of the loading links which transmit the force generator outputs to the loading tree, and hence the balance. The holes are disposed in pairs on the axes of two faces of each arm so that it is possible to vary the combinations of forces and moments being generated by each pair of force generators. Simple arithmetic will show that the forces required to generate the moment components of a typical balance are generally of the order of 30%-50% of those required for force generation, and for the best overall result it is necessary that these should not form a disproportionately small proportion of the total force available. The above arrangement is therefore designed to allow the operator some choice in the disposition of the force generators to achieve the best match between their outputs and the requirements of the balance being tested.

The forces generated in this system are reacted in the large roughly-cube-shaped cast iron box member which surrounds the loading tree at all points except at the ends of its three arms which are left exposed. Access to the ends of the loading tree arms is important for calibrating balances which cannot be accommodated within the X axis arm. For example, when calibrating the 5m mechanical balance, the loading tree is attached to a trestle on the balance moments frame via the flange on the exposed end of the lower Z axis arm. The whole assembly is positioned so that the loading centre of the calibration machine coincides with the balance virtual centre, and the axes of the loading tree are truly aligned with those of the balance. The load reaction box also has location points machined in three of its faces in positions which duplicate the arrangement already referred to for those in the loading tree; their form is however arranged to suit the location provisions in the force generator mountings. All of the principal location points were machined on a very large jig boring machine at Rolls Royce (1971) Ltd Parkside works in Coventry and we would wish to record our appreciation of the help which we received in this matter. This machine is capable of accommodating work-pieces measuring up to about 2m cube and we were double fortunate in that its accuracy had been re-certified by its makers' inspectors immediately before being used on our work. The availability of this machine also made it possible to machine all of the critical faces and mounting points on both the loading tree and the load reaction box which ensures that the dispositions and alignments of all of the elements of the loading system are as close to their correct designed arrangement as the best manufacturing processes will allow. Although it is virtually impossible to make an independent inspection check on the accuracy of the dimensions of components of these sizes

(ie 2m cube envelope size, weight 5 tonnes approximately) such checks as have been found possible have confirmed that those particular dimensions were accurate to within the best estimate of the likely measurement error ie approximately 0.04 mm.

The mass of the loading tree is supported by three vertical links from a simple mass balancing system mounted in part on the upper surface of the load reaction box and partly on its lower face. This arrangement is unfortunately sensitive to the effects of gravity in that it generates small components of force in the X-Y plane if the links incline from the vertical, and of course these forces will be measured by the balance. This problem was recognised at the design stage and calculations made at that time suggested that for balances with normal stiffness characteristics and normal distributions of loads in its various components, the maximum error likely to be incurred in the most sensitive component was of the order of 0.2% of its full scale load. In view of this finding, and of the fact that it was quite easy to calculate the interaction effects from the known mass of the suspended parts and the inclination of the links, it was decided to limit the scope of the mass balancing system to its present arrangement. In use, the displacement of the axes of the loading system from their zero load condition is measured by a sensitive transmitting cross level mounted on the upper face of the load reaction box, and the signal generated in this device is interpreted by the computer at each loading point. To the purist, it would be unthinkable to incorporate a loading system which is known to be susceptible to the sort of interactive effects described above, even though they be small and easy to calculate. It is however believed that in a closely-controlled environment such as that of the calibration process, the many attractions of the present system far outweigh its deficiencies. The final achieved accuracy of any system is an amalgam of the qualities of all of its components, and on this basis the present arrangement must rate quite highly. For example, because of its reduced size (relatively speaking), the geometry of the main components, and hence that of the load paths to the balance, has been ensured to extraordinarily close tolerances by virtue of the fact that all of the vital dimensions and alignments could be established by normal machining processes on a machine tool of the very highest quality. Thus it has been possible to realize the design objective of keeping the tolerances on all of the sensitive dimensions within one part in 10000 of their designed value. Similarly as far as can be discerned from the results of all of the calibration tests which have been performed on the force generators, these too are performing to very similar standards of accuracy. Although at the time of writing we have been unable to make a full investigation

of the deflections of the loading system under load, the present indications are that these also are quite acceptable; further light may be shed on this aspect of its performance when it is used in conjunction with the mechanical balance. Finally it must not be forgotten that it is the design of this particular loading system which makes it possible for the calibration machine to be portable and therefore capable of operating in any suitable location.

4.4 Balance mounting arrangements and the deflection compensating mechanisms

At the time when the principal elements of the loading system were being designed, the likely shape, size and mounting arrangements for typical 5m tunnel internal strain gauge balances were all at a high speculative stage. The design on which most of the existing RAE balances were based was specifically relevant to those which could be machined from a solid piece of metal, and the extension of this technique to the new balances (whose linear dimensions were likely to be increased by a factor approaching 3 relative to say an 8ft tunnel balance) - posed considerable manufacturing problems. This particular design incorporates taper joints at both ends for attachment to the model and sting, and these were then (at least in the larger sizes) subject to some criticism on account of their size, difficulty of manufacture and suspected performance deficiencies. At the same time, there were considerable doubts being expressed concerning the possibilities of isolating the load sensing elements of a 5m balance from the effects of the very high local stress levels induced by the fixing bolts in typical flange and tongue joints. This particular worry was compounded by some unfortunate experiences in the 8 ft tunnel with a bolted joint between a half model and its balance, where, once again, it was shown that variations in the load distribution in the joint bolts could affect the stress levels in the strain gauge elements, thus making the balance readings of somewhat dubious reliability.

The general conclusion was, therefore, that although the balances would be larger than the largest 8ft tunnel balances, their maximum diameters were unlikely to exceed 250 mm; their lengths, excluding the end attachments, were expected to be between 450 and 750 mm. There was much less certainty about their end fixings and it was finally agreed that the X axis arm of the loading tree must be made large enough to accommodate a balance and a two part mounting arrangement consisting of a balance adaptor and an attachment block interposed between the adaptor and the loading tree. The reason for this arrangement was quite simply the need to standardize the bolt pattern in the loading tree and at the same time to allow for a range of balance adaptors, which for their own design reasons, may have to make use of varied attachment bolt patterns. This

virtually decided the internal dimensions of the loading tree, whilst the external envelope size of the whole loading system assembly was fixed by the availability of precision machine tools which, apart from being large enough, were otherwise suitable for the final machining operations on its two main components.

The load reaction box has two arms attached to its lower face and these project in line with the Y axis to form the upper attachment points for two of the three vertical restoration jacks by means of which the whole loading system is supported from the earth frame. The third jack is attached at a point directly beneath the balance support sting on the X axis, as also is a horizontal jack controlling the position of the load reaction box in the X direction. Two further horizontal jacks are attached to the load reaction box, and these control its translation in the direction of the Y axis together with its circular motion around the Z axis; similar motions around the X and Y axes are controlled mainly by the vertical jacks. All of the restoration jacks are of a common design incorporating a ballscrew and nut driven by a stepper motor through a harmonic drive reduction gear, and each is capable of exerting a thrust of 93 kN in either direction along its principal axis. A fail-safe electromagnetic brake is included to guard against possible reverse driving through the system in the event of a power failure, which if uncontrolled could quite easily result in damage to a balance attached to the machine.

The primary function of the restoration jacks is to maintain the alignment and position of the load reaction box relative to the loading tree and by this means to ensure the proper alignment of the loading actions being applied to the balance. This is achieved by entrusting the control of the jack motors to a simple servo system which operates in response to the output signals from a number of displacement transducers positioned between the loading tree and the load reaction box. Their other important use is for controlling the motions of the loading tree when loading a balance into the machine or removing it. This process is simplicity itself and takes a little over half an hour to perform once the balance has been attached to the sting and the latter mounted in its cradle on the traversing table. Before attempting to load or remove a balance, it is first necessary to clamp the loading tree to the load reaction box by means of the bolts and spacers provided. The loading tree must then be displaced from its normal position by manipulating the restoration jack controls to bring it into such a position that there will be adequate clearance between the balance mounting block and its attachment faces inside the tree. The sting and balance

assembly is then traversed along its slides until the forward end of the attachment block first contacts a position transducer at the forward end of the X axis limb of the loading tree, and then drives it to its null position. The balance is now in the correct position along the X axis and at this point the traversing table is firmly clamped to its slides and the servo mode selector switch is moved to 'Servo Align'. In this mode the jacks move under automatic control to manoeuvre the loading system until the datum faces on the balance attachment block are exactly parallel to and displaced by a small amount from their mating faces in the loading tree. When this is completed, the Synchronous Drive switch is operated, and this drives the jacks to bring the mating faces together whilst at the same time keeping them exactly parallel and equi-distant from each other. This action is discontinued at the first observable change in the balance outputs as indicated by the panel meters, and as the final approach speed is very low there is no danger of damaging a balance by this means. After bolting the adaptor block to the loading tree, and removing the spacers tying it to the load reaction box, the balance and the machine are ready to start the calibration.

4.5 The control systems

It has already been noted that the total management of the calibration machine, and this includes the data retrieval and analysis package, is entrusted to a computer, but it would be invidious for the author to claim any responsibility for the design of this particular system. The present note would, however, be incomplete without some reference to this very important part of the equipment and what follows is necessarily a very brief description of the main functions of the control system without the benefit of any detailed descriptions of the means by which they are achieved. Suffice it to say that the whole concept of the machine as it now exists would not have been judged to be a viable proposition unless there had been some very positive assurances that the control problems were amenable to this treatment, and that this was considered to be a sensible cost-effective approach to these problems.

The possibility of automating such a system as the present had in fact been demonstrated just prior to the time when the contract for this machine was placed, when the manufacturer of the pressure measuring and control instruments announced the availability of a process control computer system for managing a number of channels of the equipment. Conversion kits were made available for addition to existing gauges and controllers to make them fully compatible with this type of control, and various equipment options were available to customers anxious to make full use of the new instruments and techniques in their own

equipment. Such customers included the airline operators who by then regularly used these pressure gauges and controllers for the semi-automatic sequencing of altimeters and other pressure sensitive gauges through a range of preset calibration pressure increments as defined by banks of manually operated switchsets or by punched paper tape and reader etc. There was therefore a complete range of standard commercially available equipment for the management of pressure control systems, and this equipment was designed to accept its instructions in digital form at normal logic voltage levels. Although the original idea was to buy the pressure control package from the manufacturers as a complete proven system, a later development led to the incorporation of this package in a much more comprehensive control and management routine designed for one of the Digital Equipment Corporation PDP 11/40 computers in the 5m instrumentation system.

It may at first sight seem to be something of a luxury to involve a computer in the control of what is to all appearances an extremely simple system, and it is only when actually looking into the mechanics of this process that the difficulties really surface. Such problems as there are do not relate to any mathematical complexity but simply to the management of what might otherwise prove to be an unmanageable amount of information from which to extract the data required at each loading point or other machine activity. It is for example, inescapable that each pressure gauge should have its own unique calibration characteristic and this is defined by reference to 40 calibration pressures generated in a Ruska Piston Pressure Gauge of $\pm 0.01\%$ of reading accuracy; intermediate pressures have therefore to be read by interpolation between these calibration points. The same sort of problem arises with the force generators which because of manufacturing limitations also have different calibrations in respect of their positive and negative force generating ends. The force generators, and certain elements of the pressure gauges, are also temperature sensitive and as a result all of them are equipped with sensitive temperature measuring elements whose outputs are read by the computer at each loading point. In addition to these perhaps more obvious activities there are a host of other tasks to be performed, many on a more or less continuous basis. Some of these are concerned with the safety of the balance, and indeed of the whole machine and its peripheral equipment, whilst others ensure that the operator's demand inputs are properly implemented by continuously checking the state of all of the sub-systems involved in the particular operation. Finally there are all of those activities which relate to data collection, recording and display, storage and final processing into a form suitable for use in the actual wind tunnel test.

The layout of the force generation control system generally follows that depicted in simplified line diagram form in Fig 12. The computer store is loaded with information relating to the geometry of the loading system in each of the possible modes of operation, the calibrations of the force generators, pressure control gauges and of the temperature and level sensors etc. Further information is supplied at the commencement of a calibration to define the location of the individual force generators and pressure controllers in relation to the chosen loading configuration, as well as other relevant facts such as the designed loading of the balance being tested.

At the beginning of any test it is first of all necessary to test all of the pneumatic systems for leaks, and this process is under the direct control of the computer working to a standard routine. Each force generator is equipped with two selector valves which enables the pressure controller output to be switched to the appropriate side of the piston and hence determine the direction of the force output. The unused side of the piston is simultaneously vented to atmosphere. However, if both valves are opened at the same time, the force generator output will be kept at virtually zero regardless of the applied pressure, and in this mode it is possible to test the system for leaks without loading the balance by more than a fractional amount. The computer overrides the normal interlocks between the valves and instructs them all to open, and then cycles the pressure controllers through a series of set point pressures. At each of these points (probably three in all) the computer switches the pressure control gauges to 'gauge' in which condition they can monitor the set pressure levels over a specified period of time and thus detect any leaks. At the end of this test the computer demands zero pressure of all of the controllers, and when this condition is achieved all of the force generator valves are selected 'off', thus venting both sides of the pistons to atmosphere and establishing true zero load conditions on the balance.

Subsequent demands for a particular loading action are read into the computer from a digital keyboard and on the basis of this information, plus that which is already held in store, the computer can select the appropriate force generators and calculate the level and direction of their required outputs. It then progresses to interpret this information and convert it to actual gauge settings by calculations involving the interpolation of the force generator and pressure control manometer calibrations. As soon as the gauges have been set to their required readings, the pressure controllers are activated and they then proceed to vary their output pressure levels until they coincide, within fixed

preset error margins, with the demanded values. Whilst this loading action is progressing, the computer ensures safety by maintaining a continuing check on the strain gauge outputs from the balance and on the various sensors incorporated in the loading system. At the same time, the change of load will bend the balance and sting, thus disturbing the alignment of the balance axes with those of the loading system. These movements are detected by the loading system alignment transducers which activate the servo drives on the restoration jacks to apply the necessary corrective action; any changes in the level of the loading system which result from these actions are logged by the computer and, if large enough, are subsequently used to correct the values of the applied force(s). When all of the actions are complete, as judged by the levels of the errors signalled by the various transducers in the whole loading system, the computer logs the information and files it for later use.

4.6 Performance

One of the declared objectives of the design study was that of developing a loading system which would be capable of applying the loads to a balance with an overall accuracy of $\pm 0.05\%$ of full scale. This can only be regarded as a fairly generalised statement of a requirement as it has to be related not only to a wide range of balance loadings, but also to the very practical limitations imposed on the design by such considerations as cost effectiveness. For example each axis pair of force generators can generate either a force, a moment, or a combination of the two. Clearly, the total effort available from the force generators should match that required by the loading case as closely as possible - thus making full use of the whole of the range of the pressure control instruments - if the highest standards of accuracy are to be achieved. This implies the availability of a range of fully interchangeable force generators which between them can provide full coverage for the whole range of balance loadings. In addition to the six force generators supplied as initial equipment and sized to be capable of loading the mechanical balance over its complete and half model ranges, four more are at present being manufactured; the total inventory will then consist of 4 x 90 kN, 2 x 50 kN, 2 x 20 kN and 2 x 10 kN (nominal) units. It will also be apparent that the ratio between the efforts required to generate the force and the moment components is important, as the presence of hysteresis or any similar effect which results in a loss of precision in the outputs from the force generators has a scaled effect on the final achieved accuracy. Consider the case in which the minor load produced by an axis pair absorbs 30% of the total force generator outputs, and assume that there is $\pm 0.01\%$ full scale load hysteresis in

their outputs, then the effective uncertainty in generating the minor load component is equal to $\pm 0.033\%$ of its full scale value. This situation would not have arisen had it been possible to incorporate a compensating lever system (similar to that shown in Fig 6) into the loading system, as in this case the full force generator output would have matched the requirement of the single load component, and the effect of any hysteresis component would then have been purely that of the prime mover ie $\pm 0.01\%$ full scale with no amplification factor.

Again it will be seen that the hypothetical situation chosen for this example could be improved by adjusting the length of the moment arm of each of these two force generators until their outputs were equally divided between the requirements of the force and moment components. In this case, the effective hysteresis would have been the same in each component, ie double that of the basic force generator value. Unfortunately an adjustable system such as this would have been enormously costly to incorporate into any practicable design of calibration machine, and any such thoughts were dismissed. For somewhat similar reasons it was also decided not to attempt to provide any alternative fixed mounting points for the force generators, but to rely on their continued improvement by development as the most promising solution to the problem of ensuring adequate performance under all operating conditions.

In the course of the development work which culminated in the calibration of the present set of force generators, the dangers arising from possible hysteresis in them have been of major concern, and they now appear to have been reduced to virtual unimportance simply by changing the operating technique. The method chosen is one which is well known to instrumentation personnel and which seeks to ensure that each test point is on the same limb of the hysteresis loop by approaching the demanded pressure from a lower level. This is quite straightforward for increasing load (pressure) increments and for decreasing increments it merely involves driving the pressure controller to a pre-determined increment below the demanded pressure before reversing the process to approach the required value as before. This routine has been included in the control package, but the possible benefits from it have not yet been explored on a balance. A somewhat similar method was also used when calibrating the force generators at NPL, although there were some minor modifications made to take account of the operating requirements of the machines there. As may be seen in Fig 10 the standards of accuracy achieved in the system when operating in this mode are quite high.

The force generator calibration charts are very similar to those for the pressure gauges inasmuch as they give the gauge readings relating to the gas pressures in the force generators at each loading points as determined by the Force Standard Machine, which itself has an accuracy of $\pm 0.0004\%$ of reading; the gauge readings appropriate to forces intermediate between the calibration points have therefore to be obtained by interpolation. It was originally intended that the force generator calibrations for the mechanical balance and balance calibration machine commissioning trials should be obtained by referring each to its own dedicated pressure gauge, thus eliminating the Primary Pressure Standard errors from the results. In the event however, practical difficulties with the use of the equipment of NPL prevented this, and they were all calibrated against the same gauge. The gauge readings at each load calibration point have therefore to be referred back to the gauge calibration charts in order to transfer the force generator calibrations from one gauge to another, but as all of the gauges were calibrated in parallel the errors involved in this transfer should not exceed those in the initial transfer of the primary calibration pressures to the gauges. The primary standard instrument itself has a guaranteed accuracy of $\pm 0.01\%$ of reading and it would seem to be most unlikely that the transfer errors in a calibration set-up with such an instrument would exceed one half of this amount. The force generator calibrations are also affected by temperature variations which have the effect of increasing their force outputs at constant pressure by 0.002% of reading per 1 K temperature rise; the corresponding effect of temperature on the geometry of the loading system is to increase the lengths of the moment arms by one half of that amount.

The other possible source of error in the loading system is inherent in the choice of material for the pressure sensitive element in the pressure gauge, which in the case of the Texas Instruments Precision Gauge is fused quartz. Although this material has excellent properties for use as a control spring it is temperature sensitive, and because of this the pressure capsule is enclosed within a temperature controlled oven built into the instrument itself. An 0.1 K change in the controlled set point of this oven will change the calibration constant of the gauge by $\pm 0.0012\%$ and this oven temperature is one of the parameters which is monitored by the computer to ensure that it does not deviate from its normal value by more than this amount.

It is now possible to list the various contributions to the overall accuracy of the loading actions in the machine and these are presented in the table below where they are expressed as percentages of the full scale values for

the force and moment components generated by a typical axis pair of force generators. For this purpose, it is assumed that the force generators are ideally matched to the outputs demanded of them, and all of the other relevant conditions are as discussed earlier in this section. The values ascribed to some of the parameters in the table were obtained from manufacturers' declared information or, where this is not possible, from a careful assessment of the likely outcome of actions performed, for example, on machine tools of well certified capabilities and known operating characteristics.

Error source		Error % fs in the	
		Force component	Moment component
1	Geometry of the loading system	Nil	≤ 0.005
	Temperature	Nil	0.0001
2	Pressure gauge		
	Calibration transfer error	≤ 0.005	≤ 0.005
	Capsule temperature	≤ 0.0012	≤ 0.0012
3	Force generator calibration excluding error source 2	≤ 0.0143	≤ 0.033
	Temperature	0.0002	0.0002
Total error		≤ 0.0207	≤ 0.0445

All of the above figures represent errors which are no larger than 0.01% of full scale in the relevant primary parameter, and it will be appreciated that many of them are extremely difficult to verify. It is therefore necessary to assume that the conditions established in the tests which yielded these values were as completely relevant to the conditions obtaining in the calibration machine as it was possible to make them. The validity of this assumption can only be assessed by operating the machine in conjunction with the mechanical balance, and tests about to commence at the manufacturer's works should shortly throw some further light on this problem. Even so, there may still be some residual doubts remaining due to the difficulties which may be anticipated in reconciling the machine's balance axes loads with the mechanical balance's measurements relative to fixed wind axes. Deflections in the calibration machine, the balance calibration frame and the balance moments frame and linkages etc to which it is attached, will need to be carefully measured and interpreted if any meaningful results are to be obtained from this exercise.

Finally it cannot be too strongly emphasised that these figures relate to a system in which all of the equipment involved is working at its peak of

performance, and in which the force generators are ideally matched to their required outputs. Any deviations from these conditions will inevitably degrade the overall performance of the machine, and this must be accepted as part of the price which is paid for holding the initial costs at an acceptable level.

5 CONCLUDING REMARKS

The balance calibration machine which has been described in this Report, has been designed in response to a more widely ranging specification than any of its predecessors. In order to accommodate the many often severe demands which have been made upon it, it has been necessary to adopt some novel approaches to several of the problems involved in the generation and control of calibration forces, as well as to accept some slight limitations on the overall standards of accuracy which may be achieved under certain conditions.

The most radical departure from the traditional calibration process lies in the total reliance which is placed on the principle of force generation and its definition by means of devices which derive their power from a compressed gas. Compressed gases and fluids have often been used for force generation, but they have always been used in conjunction with a precision load cell or other measuring system by means of which the output from the actuator is defined. The present system is based entirely on commercially available equipment whose performance has been well established both in the manufacturers' and the users' laboratories. A note of caution must however be sounded, for it must always be remembered that in a calibration situation such as applies to the present machine, the equipment involved is being used at the limits of its capabilities. In recognising this situation we must also accept its implications and be prepared to use and care for the equipment in ways which are compatible with the very high standards expected of it. We must for example be prepared to subject the pressure control gauges to regular calibrations against a primary standard device of the highest possible accuracy ($\pm 0.010\%$ of reading or better) and to ensure that they and their pressure controllers are maintained at peak performance. This type of loading system is practicable for one reason only - the availability of a suitable process control computer. Were this not so it would be quite impossible to handle the mass of component calibration information and other data which must be interpreted in order to define the pressure gauge settings required at each loading point.

Another unusual requirement of this machine is that of portability - even though it may measure more than 5m square and 3m high and weigh more than 30 tonnes! This feature is essential, and enables the machine to be used on the

mechanical balance cart as well as on an isolated site for its primary purpose of calibrating strain gauge balances. Here again it is unusual inasmuch as it is able to cater for the needs of all forms of balances, both internal and external, which comply with certain conditions stemming from its overriding responsibility for calibrating balances in the 100 kN bracket and above. To do this, the machine's component parts, and particularly the loading system, have to be large enough to accommodate the balances and sufficiently strong and rigid to resist the very heavy loads imposed upon it. With component sizes such as these, it is unreasonable to expect the machine to be able to cope with balances whose maximum designed load ranges vary from its own design figures by too great a margin, and this probably means that a balance which is too heavily loaded for calibration in the 8 ft tunnel machine is a suitable candidate for testing in the 5m machine.

It is always possible with the benefit of hindsight to identify areas which are capable of being improved, and in the present case these seem to be limited to the force generators where the use of one of the new sealing techniques could possibly eliminate one of the last of the intangibles in the design. In all other respects, the precision of the whole loading system appears to have reached the ultimate in relation to what is sensibly required, and, in some areas, to what it is possible to achieve.

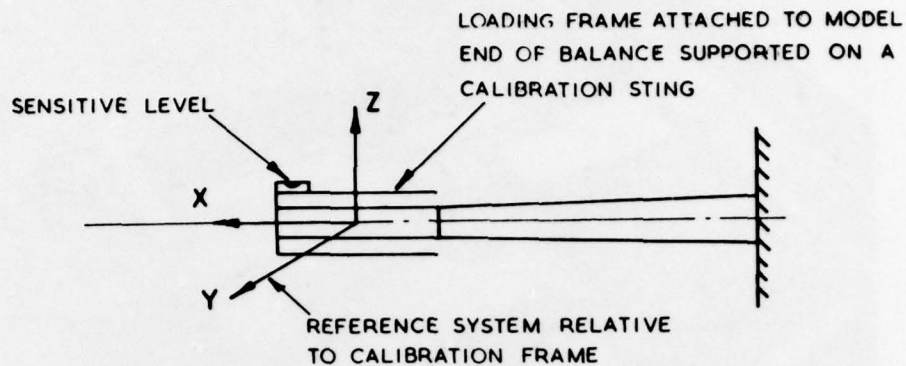

(a) INITIAL ZERO LOAD CONDITION



(b) LOADED CONDITION

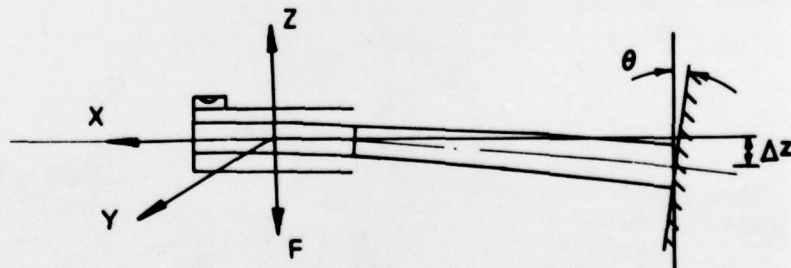

(c) LOADED AND AXES RE-ALIGNED

Fig 1 Diagram of adjustments required to correct for balance and sting deflections under load

Fig 2

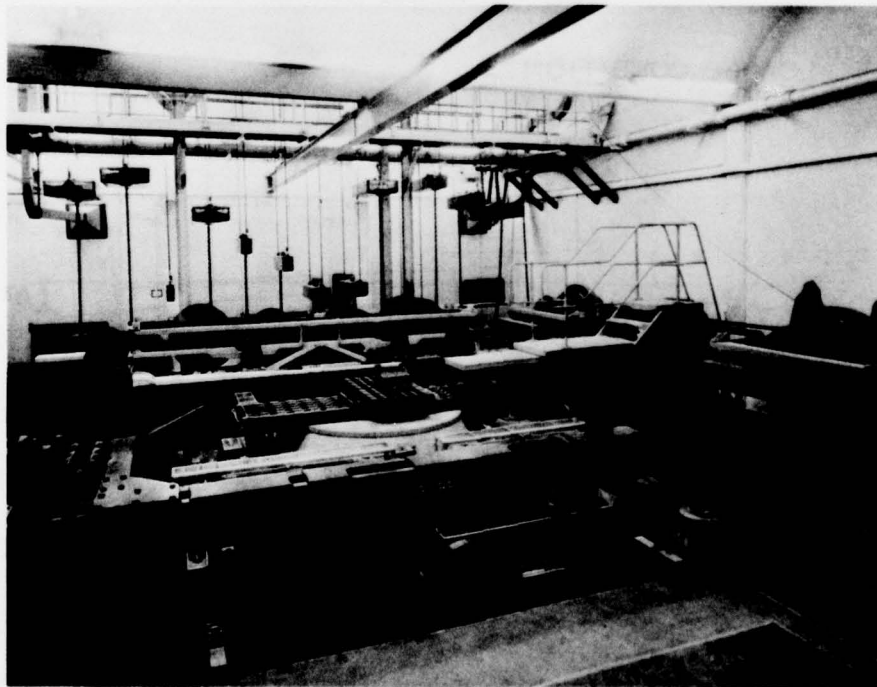
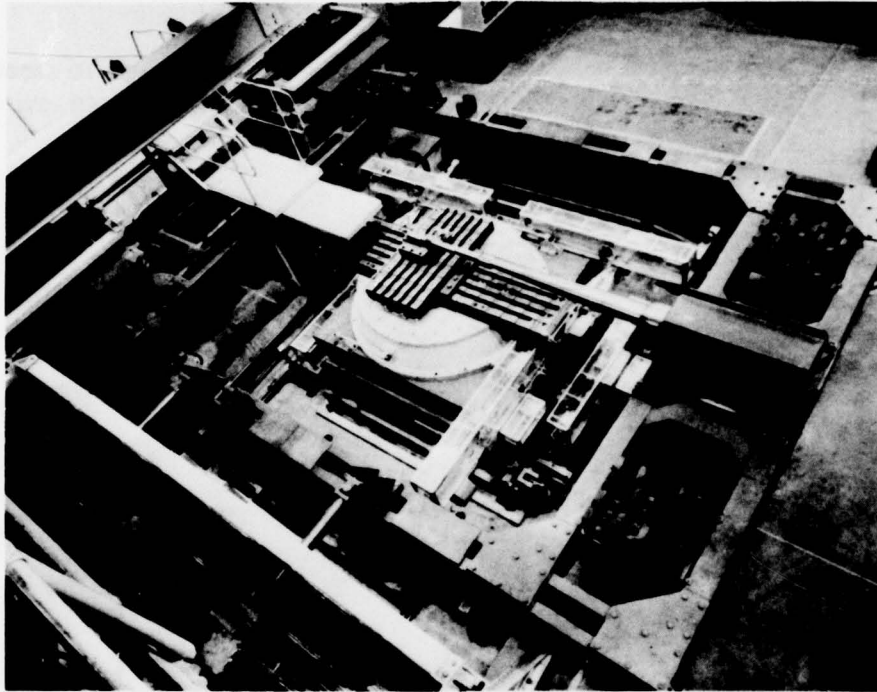

Fig 2 Strain gauge balance calibration machine.
RAE 8ft x 8ft supersonic wind tunnel

Fig 3

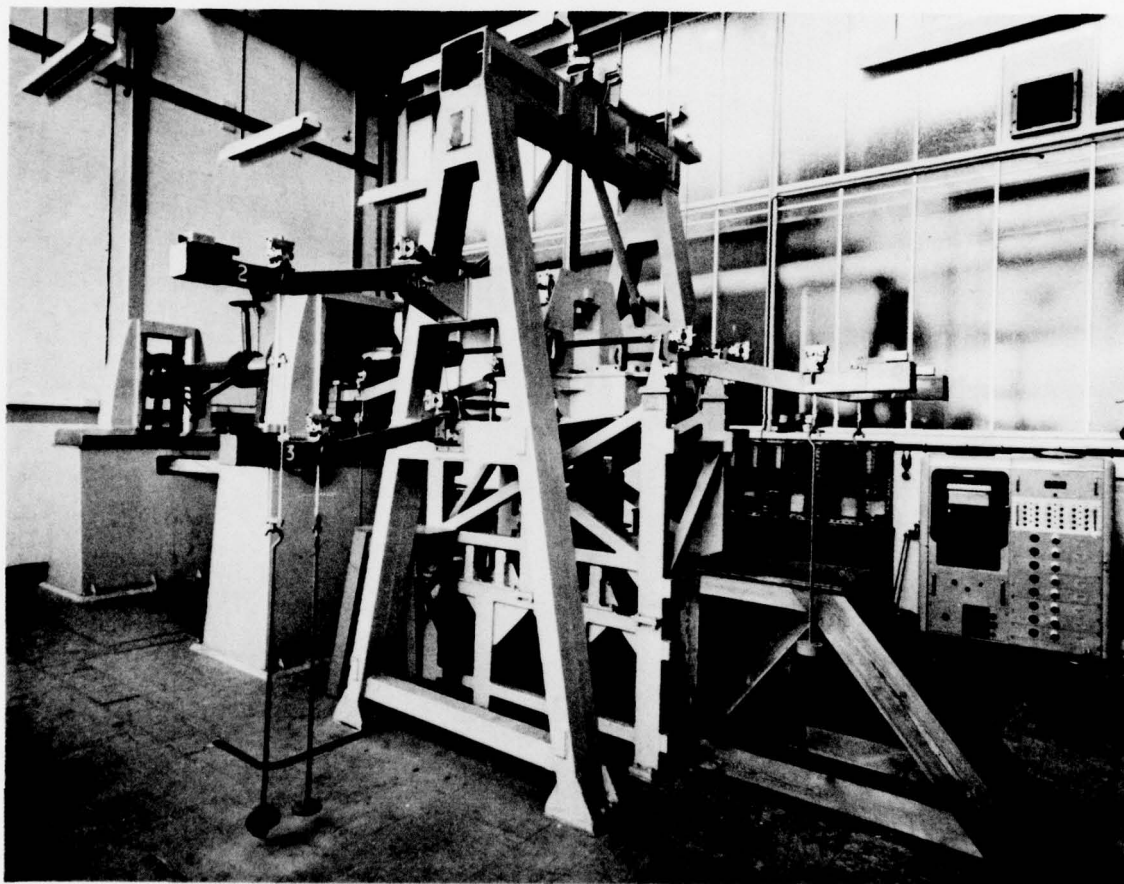

Fig 3 Strain gauge balance calibration machine.
RAE 3ft x 4ft supersonic wind tunnel

Fig 4

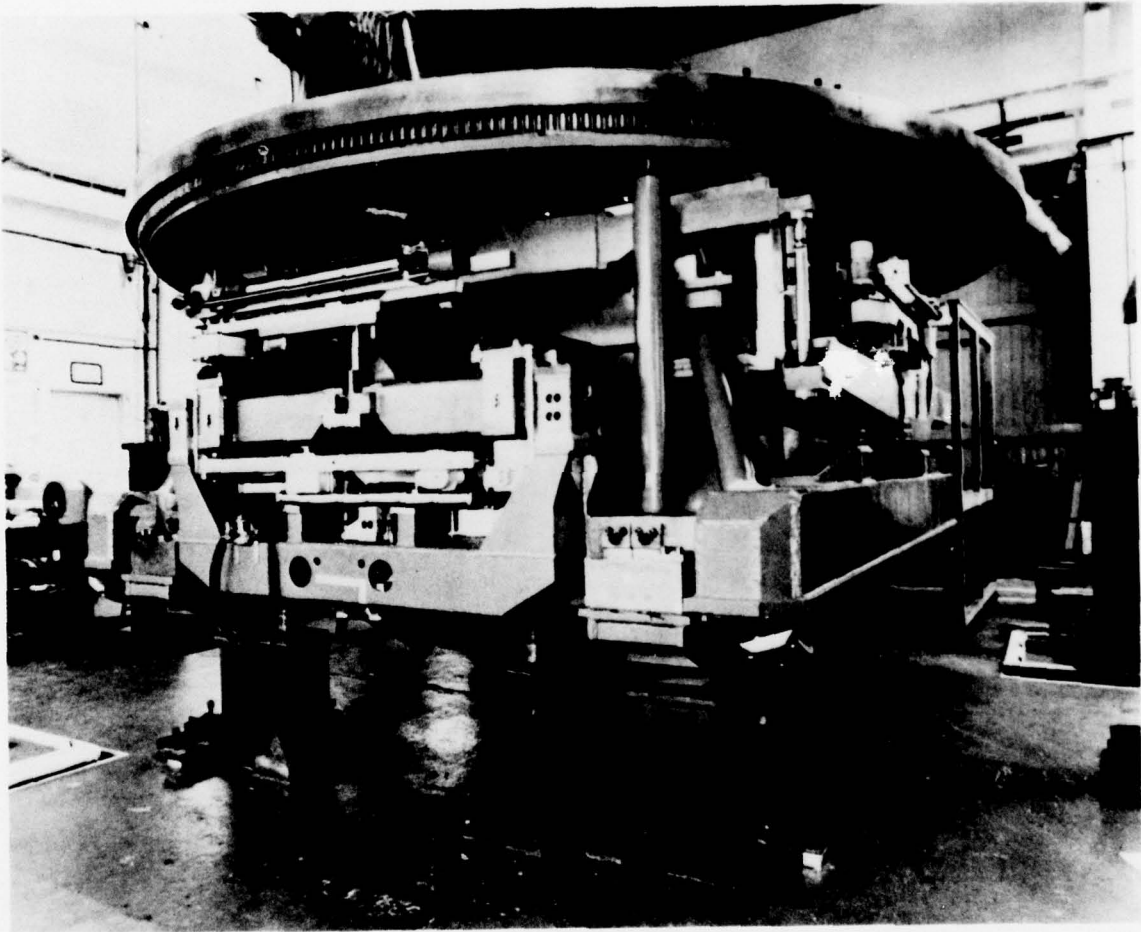

Fig 4 5m mechanical balance-assembly at maker's works

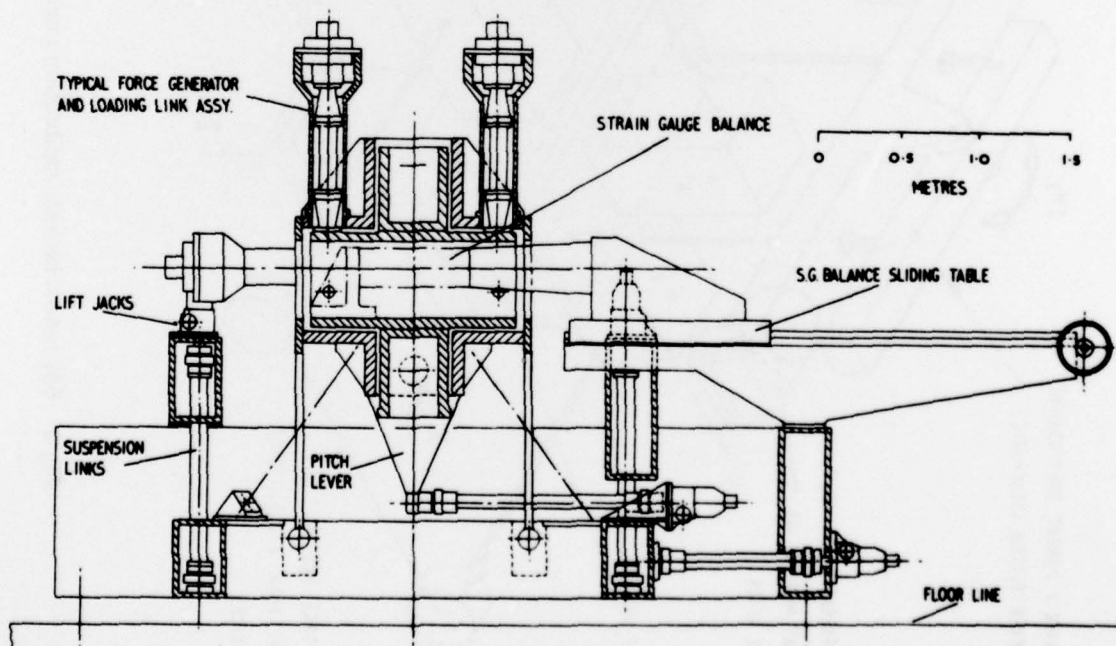
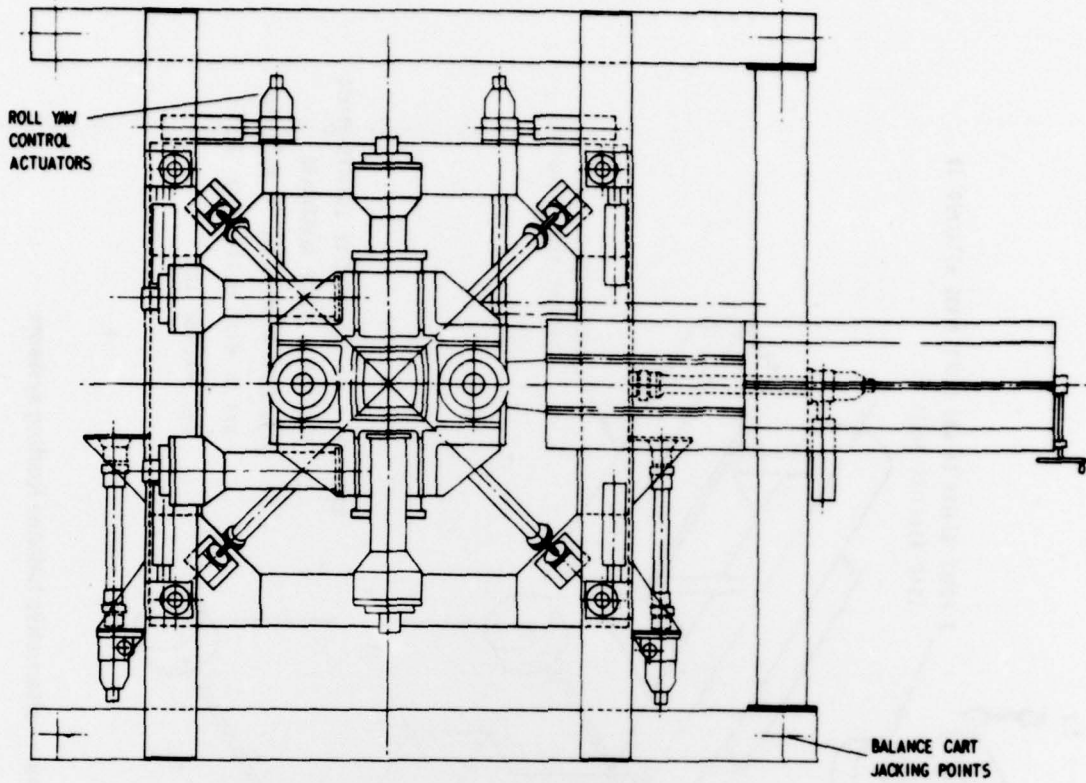

Fig 5 1972 design study proposed arrangement of balance calibration machine

Fig 6

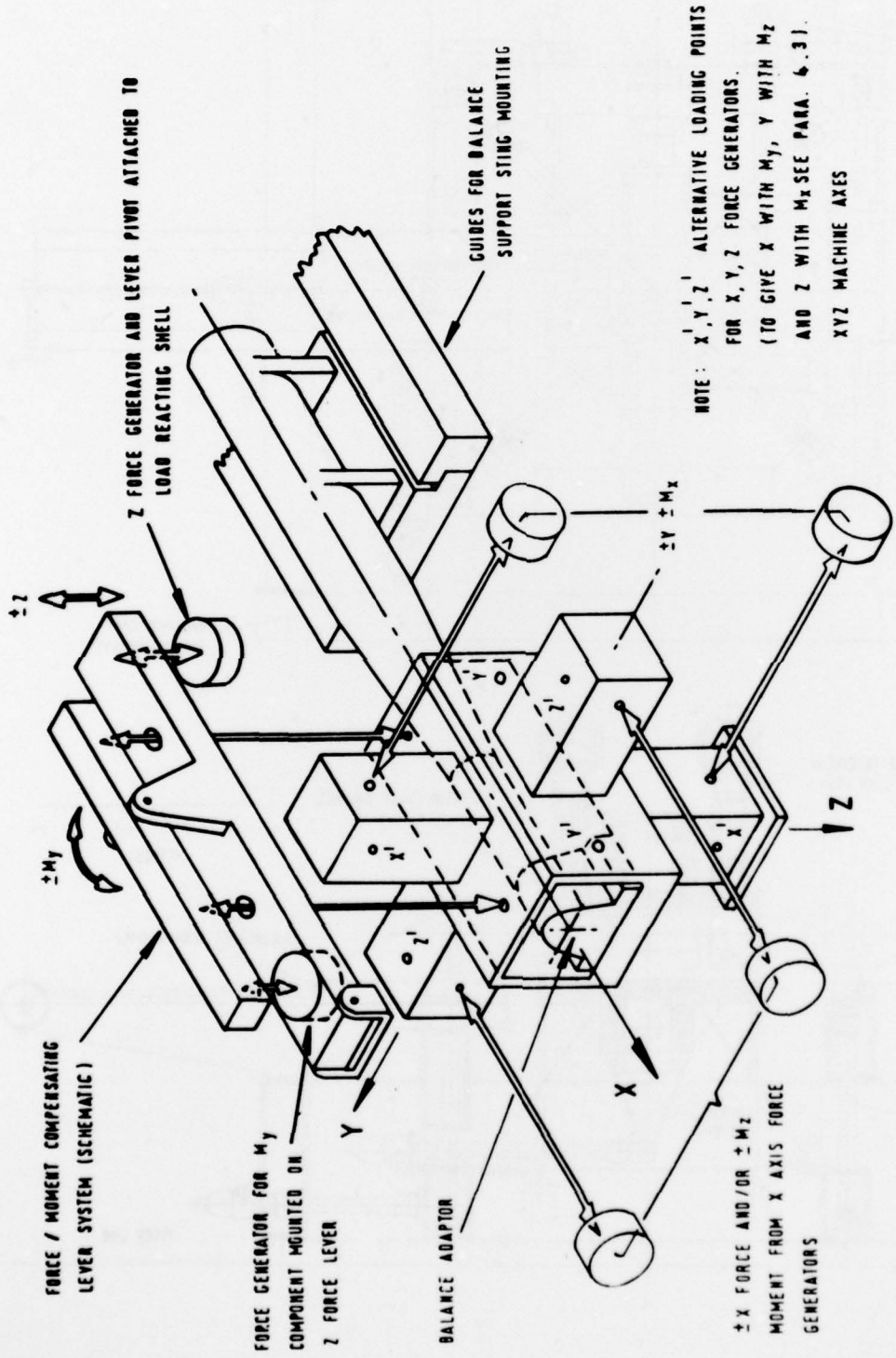

Fig 6 5m tunnel balance calibration machine — alternative balance loading systems

Fig 7

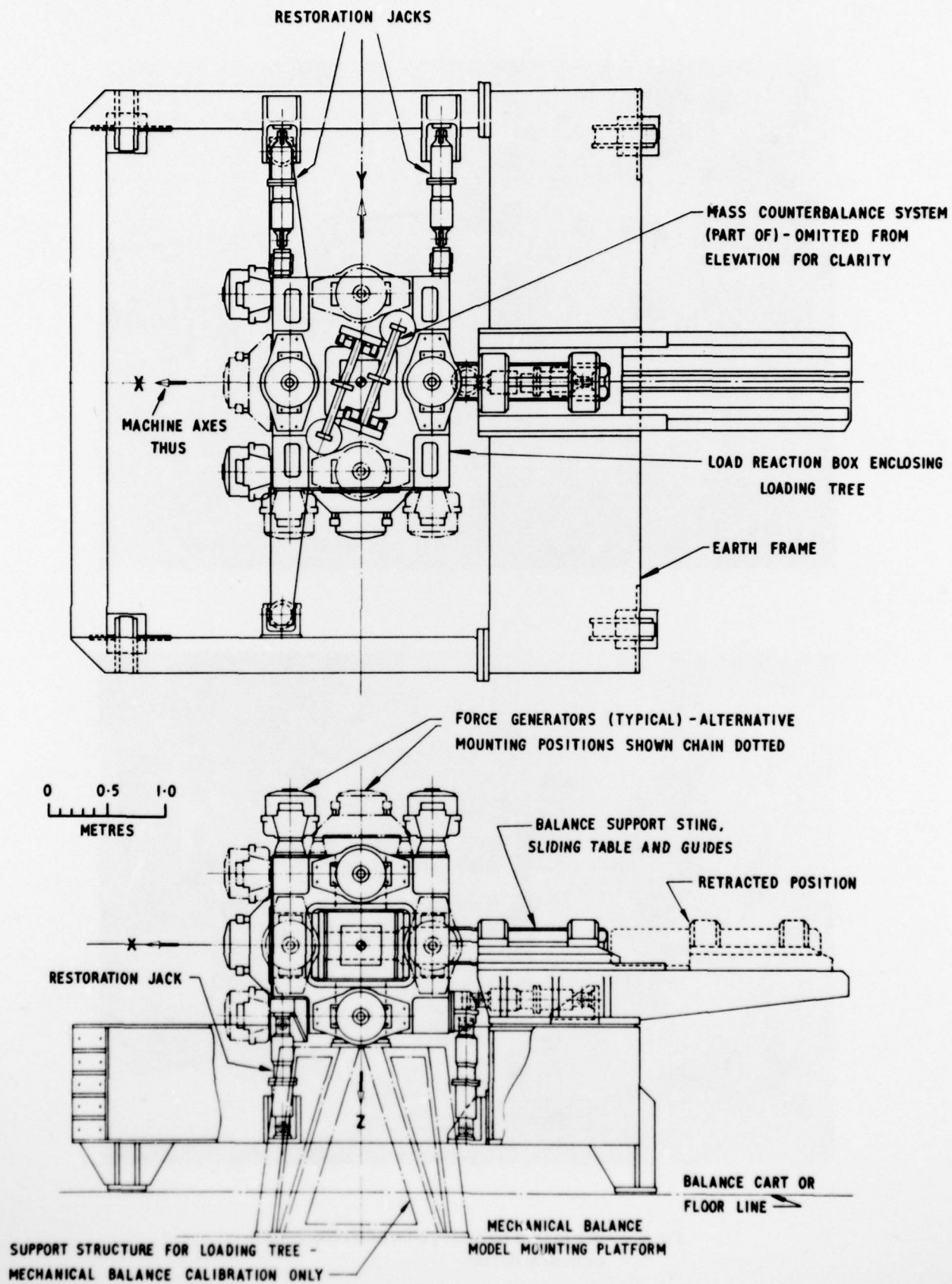

Fig 7 5m tunnel balance calibration machine - GA

Fig 8

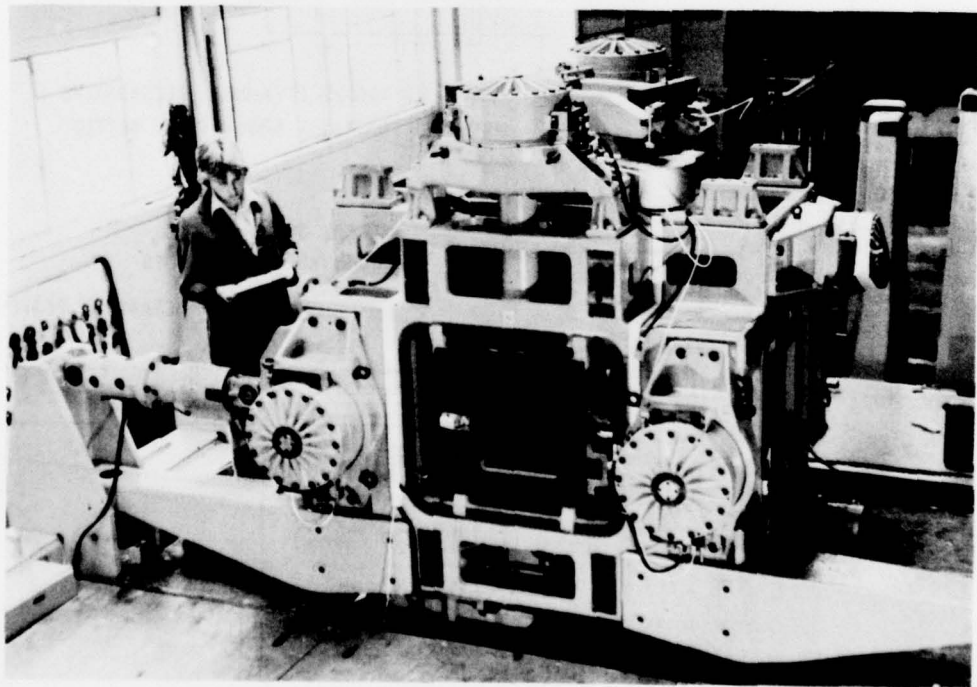
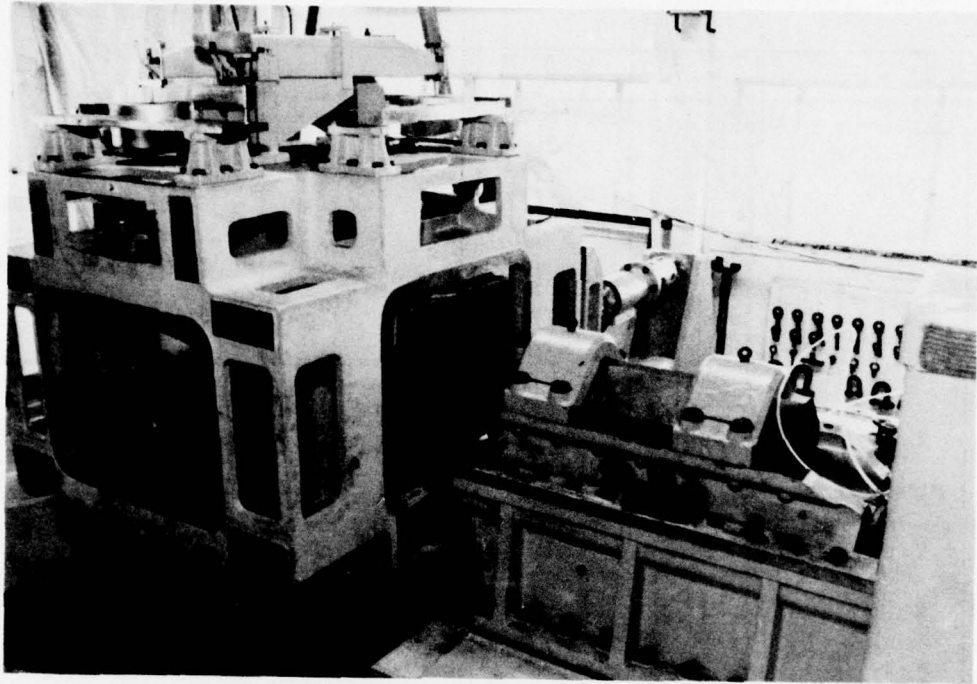

Fig 8 5m tunnel balance calibration machine —
assembly details

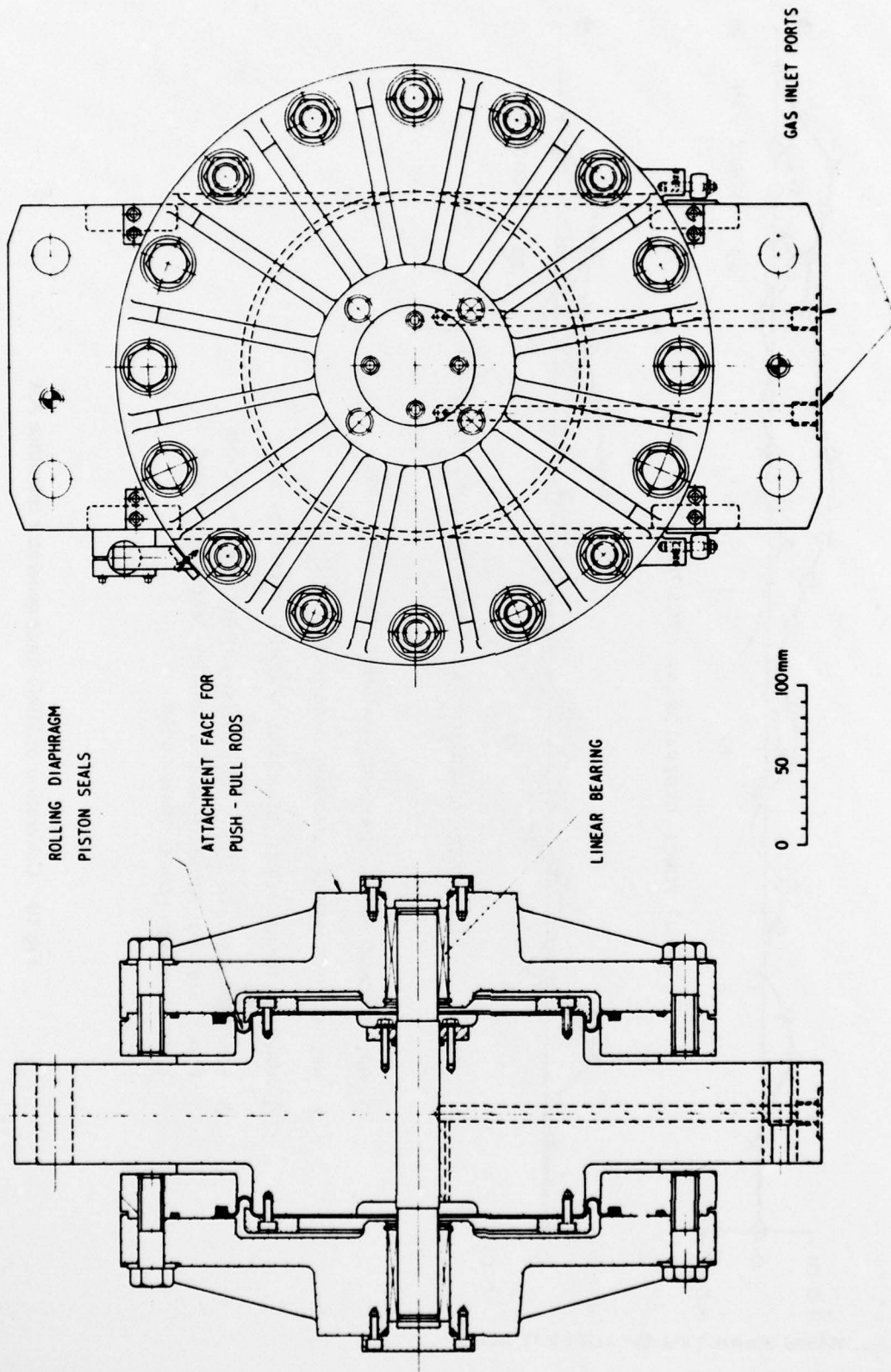
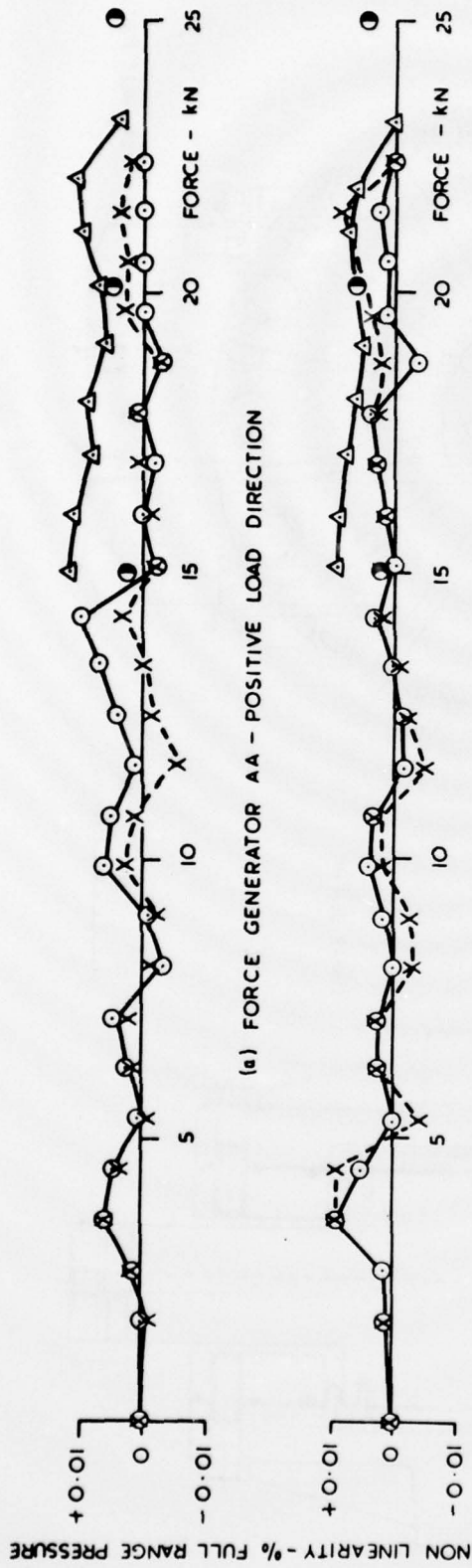

Fig 9

Fig 9 Arrangement of 50kN bi-directional force generator (1.4 MPa working pressure)

Fig 10



- NPL 5 TONNE FORCE STANDARD MACHINE FEBRUARY 1976
- X NPL 5 TONNE FORCE STANDARD MACHINE APRIL 1976
- △ NPL 50 TONNE FORCE STANDARD MACHINE APRIL 1976
- NPL COMPARATIVE TESTS (UNPUBLISHED) BETWEEN 5 TONNE FORCE AND 50 TONNE FORCE STANDARD MACHINES USING A SUB - STANDARD FORCE TRANSDUCER

Fig 10 Calibration of 20kN force generator reference AA

Fig 11

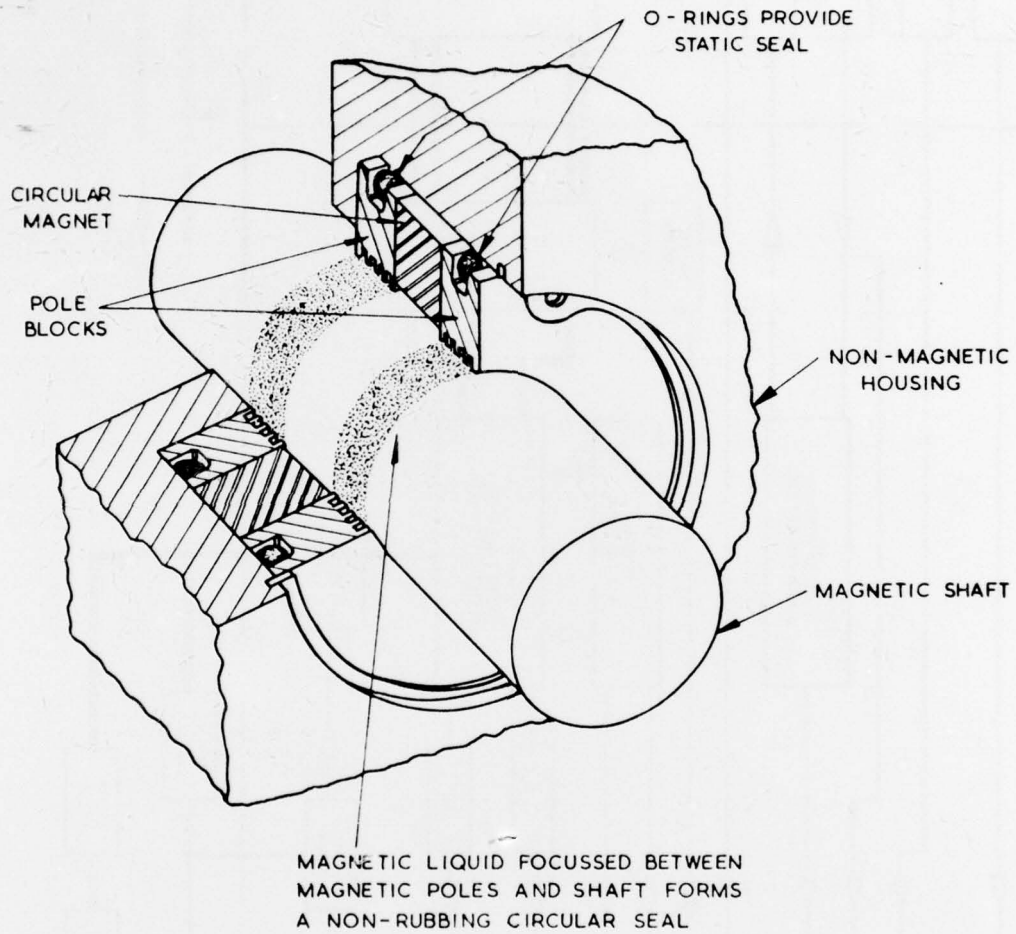

Fig 11 Schematic arrangement of magnetic liquid shaft (piston) seal

Fig 12

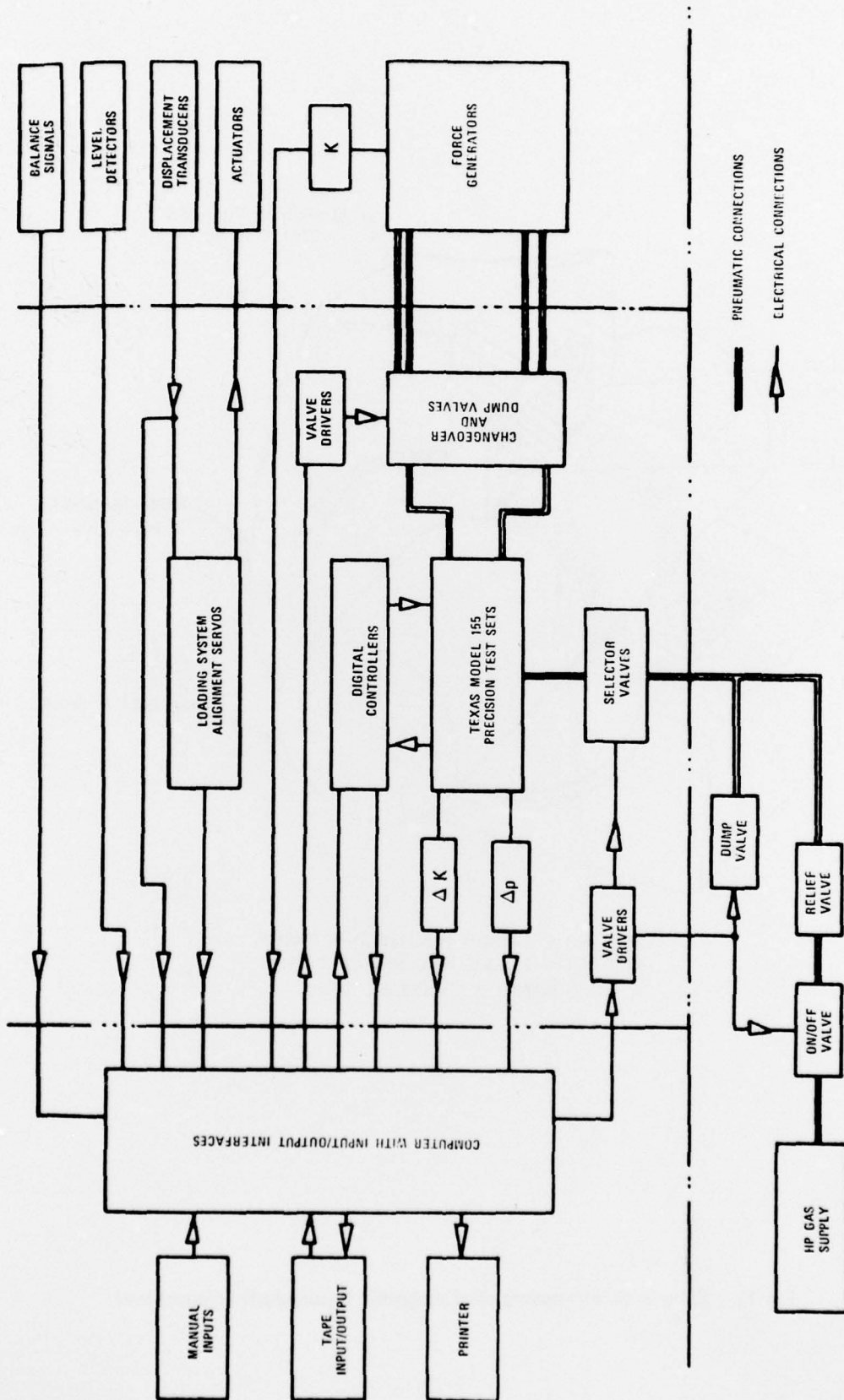

Fig 12 Balance calibration machine — schematic control system

REPORT DOCUMENTATION PAGE

Overall security classification of this page

UNCLASSIFIED

As far as possible this page should contain only unclassified information. If it is necessary to enter classified information, the box above must be marked to indicate the classification, e.g. Restricted, Confidential or Secret.

1. DRIC Reference (to be added by DRIC)	2. Originator's Reference RAE TR 79039	3. Agency Reference N/A	4. Report Security Classification/Marking UNCLASSIFIED
5. DRIC Code for Originator 7673000W	6. Originator (Corporate Author) Name and Location Royal Aircraft Establishment, Farnborough, Hants, UK		
5a. Sponsoring Agency's Code N/A	6a. Sponsoring Agency (Contract Authority) Name and Location N/A		
7. Title A heavy duty balance calibration machine for the RAE 5m low speed wind tunnel			
7a. (For Translations) Title in Foreign Language			
7b. (For Conference Papers) Title, Place and Date of Conference			
8. Author 1. Surname, Initials Brown, E.C.	9a. Author 2	9b. Authors 3, 4	10. Date Pages Refs. April 41 - 1979
11. Contract Number N/A	12. Period N/A	13. Project	14. Other Reference Nos. Aero 3452
15. Distribution statement (a) Controlled by - DRPC via DRIC (b) Special limitations (if any) -			
16. Descriptors (Keywords) (Descriptors marked * are selected from TEST) Calibration. Balance.			
17. Abstract The 5m low speed wind tunnel at RAE Farnborough will make use of a wide variety of balances for measuring the aerodynamic loads on the models to be tested in it. These will include internal and external strain gauge balances for complete and half model testing, as well as a mechanical lever balance which can cope with tests on both forms of model. Maximum model normal forces will approach 130 kN in half model testing and up to 90 kN on complete models. This Report reviews the background to the calibration problem and then describes the development of the design of a calibration machine which is sufficiently versatile to cope with all of the foreseeable types of balances which will be used in the tunnel. The loading system of this machine is based on pneumatically-powered force generators controlled by a computer, and these are capable of generating any combination of loads in response to an input demand originating from a manually operated switchboard or from a stored programme. A typical 400 point calibration occupies less than 12 machine hours of testing with one operator in attendance.			

F 5910/1