

AD-A077 213 SOUTHWEST RESEARCH INST SAN ANTONIO TX MOBILE ENERGY DIV F/G 14/2
EVALUATIONS OF COMMERCIAL INDUCTION AIR MONITORS AND GO/NO-GO 0--ETC(U)
AUG 79 F M NEWMAN DAAE07-78-C-5024
UNCLASSIFIED SWRI-MED106 NL

1 OF 1
AD
A077213



END
DATE
FILMED
12-79
DDC

LEVEL

AD

12

AD A 077213

EVALUATION OF COMMERCIAL
INDUCTION AIR MONITORS
AND
GO/NO-GO OIL QUALITY TESTERS
AS
BUILT-IN TEST EQUIPMENT
(BITE)

Interim Report No. MED106

Prepared by

Frank M. Newman
Mobile Energy Division

DDC
RECEIVED
NOV 26 1979
REGISTRY
E

Prepared for

U.S. Army Tank Automotive Command
Procurement and Production Directorate
Detroit, Michigan 48090

DDC FILE COPY

Contract No. DAAE07-78-5024

Approved for public release; distribution unlimited

August 1979



SOUTHWEST RESEARCH INSTITUTE
SAN ANTONIO HOUSTON

79 11 23 001

Disclaimers

The findings in this report are not to be construed as an official Department of the Army position unless so designated by other authorized documents.

Trade names cited in this report do not constitute an official endorsement or approval of the use of such commercial hardware or software.

DDC Availability Notice

Qualified requestors may obtain copies of this report from Defense Documentation Center, Cameron Station, Alexandria, Virginia 22314.

Disposition Instructions

Destroy this report when no longer needed. Do not return it to the originator.

UNCLASSIFIED

SECURITY CLASSIFICATION OF THIS PAGE (When Data Entered)

REPORT DOCUMENTATION PAGE		READ INSTRUCTIONS BEFORE COMPLETING FORM
1. REPORT NUMBER MED106	2. GOVT ACCESSION NO.	3. RECIPIENT'S CATALOG NUMBER 9
4. TITLE (and Subtitle) EVALUATIONS OF COMMERCIAL INDUCTION AIR MONITORS AND GO/NO-GO OIL QUALITY TESTERS AS BUILT-IN TEST EQUIPMENT (BITE)	5. TYPE OF REPORT & PERIOD COVERED Interim Report	
7. AUTHOR(s) Frank M. Newman	6. PERFORMING ORG. REPORT NUMBER MED106	
9. PERFORMING ORGANIZATION NAME AND ADDRESS Southwest Research Institute Mobile Energy Division P.O. Drawer 28510, San Antonio, TX 78284	8. CONTRACT OR GRANT NUMBER(s) DAAE07-78-5024 New	
11. CONTROLLING OFFICE NAME AND ADDRESS U.S. Army Tank Automotive Command Procurement and Production Directorate Detroit, Michigan 48090	10. PROGRAM ELEMENT, PROJECT, TASK AREA & WORK UNIT NUMBERS 15 DAAE07-78-C-5024	
14. MONITORING AGENCY NAME & ADDRESS (if different from Controlling Office) 14 SWRI - MED106	12. REPORT DATE August 1979	
	13. NUMBER OF PAGES 64	
	15. SECURITY CLASS. (of this report) Unclassified 12/69	
15a. DECLASSIFICATION/DOWNGRADING SCHEDULE		
16. DISTRIBUTION STATEMENT (of this Report) Approved for public release; distribution unlimited		
17. DISTRIBUTION STATEMENT (of the abstract entered in Block 20, if different from Report)		
18. SUPPLEMENTARY NOTES		
19. KEY WORDS (Continue on reverse side if necessary and identify by block number) BITE Oil Contaminants AIR BITE Used Oil Analysis OIL BITE Oil Condition Monitors Air Contaminants Built-In-Test Equipment		
20. ABSTRACT (Continue on reverse side if necessary and identify by block number) In the primary phases of this program, existing commercial AIR and OIL built-in test equipment (BITE) have been reviewed for military vehicle engine application. Current and potential manufacturers of BITE devices were contacted and interviewed, after which potential AIR and OIL BITE were selected for bench testing. These tests produced results of sufficient promise to justify preliminary field evaluation. The field test has been designed to evaluate the BITE devices in actual field operations in order to experience the full range		

411 162

JOB

UNCLASSIFIED

SECURITY CLASSIFICATION OF THIS PAGE(When Data Entered)

20. ABSTRACT (Cont'd)

of environmental and operational conditions. The field test has been underway only a short time, and the preliminary data is inconclusive because of the small data volume.

Accession For	
NTIS GRA&I	<input checked="" type="checkbox"/>
DDC TAB	<input type="checkbox"/>
Unannounced	<input type="checkbox"/>
Justification	
By _____	
Distribution/ _____	
Availability Codes	
Dist	Avail and/or special
A	

UNCLASSIFIED

SECURITY CLASSIFICATION OF THIS PAGE(When Data Entered)

TABLE OF CONTENTS

<u>Section</u>	<u>Page</u>
I. OBJECTIVES.....	3
II. APPROACH.....	3
III. PROGRAM SCHEDULE.....	4
IV. BACKGROUND.....	4
A. General Principles.....	4
1. AIR BITE.....	5
2. OIL BITE.....	5
a. Viscosity.....	6
b. Acidity.....	6
c. Wear Metals.....	7
B. Potential BITE Principles.....	7
1. AIR BITE.....	7
2. OIL BITE.....	11
a. Viscosity.....	11
b. Acidity.....	11
c. Wear Metals.....	12
V. COMMERCIAL BITE SURVEY.....	13
VI. LABORATORY TEST PROGRAM.....	18
A. AIR BITE.....	18
B. OIL BITE.....	22
VII. FIELD TEST PROGRAM.....	23
A. AIR BITE.....	24
B. OIL BITE.....	26
VIII. INTERIM SUMMARY.....	32
IX. PLANS.....	32
A. AIR BITE.....	32
B. OIL BITE.....	35
APPENDICES	
A. Program Briefing.....	A-1
B. Donaldson Dust Detector.....	B-1
C. Lube Safe Analyzer.....	C-1

79 11 23 001

LIST OF ILLUSTRATIONS

<u>Figure</u>		<u>Page</u>
1	General Concept of Filter Type Dust Detector.....	7
2	Optical Dust Detector Based on Light Obscuration.....	8
3	Reverse Light Scattering Dust Detector.....	10
4	Impinger-Optical Reflection Type Dust Detector.....	11
5	Sensor for Donaldson Dust Detector.....	20
6	Response Time of Donaldson Dust Detector.....	21
7	M60 Tank with Air Duct on Filter Box.....	24
8	Donaldson Dust Detector Installed on M113 Vehicle "A".....	26
9	Donaldson Dust Detector Installed on M113 Vehicle "B" (First View).....	27
10	Donaldson Dust Detector Installed on M113 Vehicle "B" (Second View).....	27
11	Overall View of M113 Operator Area With Installed Signal Box.....	28
12	Close-Up View of M113 Operator Area With Installed Signal Box.....	28
13	Modified Flange and Elbow for Dust Detector Installation on M60 Vehicle.....	29
14	Complete Duct With Detector for M60 Installation.....	29
15	Dust with Detector in the Installed Position on M60 Vehicle.....	30
16	Sensor Access on Dust Detector.....	30
17	Extended Program Plan.....	33

LIST OF TABLES

<u>Table</u>		
1	Program Schedule for BITE.....	4
2	Potential Suppliers.....	17
3	Detection Levels of Donaldson Dust Detector.....	19

I. OBJECTIVES

The objectives of this program are as follows:

- Investigate commercially-available Built-In Test Equipment (BITE) for monitoring engine oil condition and engine induction air for dirt.
- Provide technical support for procurement, laboratory evaluation, and analysis of commercial OIL BITE and AIR BITE devices to determine units suitable for field test evaluation.
- Provide technical support and planning for field analysis of BITE devices.
- Provide necessary data to determine effectiveness of BITE devices, approximate cost, and economic justification.
- Provide a report including all data, specifications, and engineering drawings required for the preparation of a procurement package for those BITE devices which prove effective.

II. APPROACH

The program consists of two BITE areas, OIL BITE and AIR BITE. OIL BITE is concerned with oil viscosity monitoring, oil acidity and oil metallic content. The purpose of OIL BITE is to indicate when the lubricating oil has ceased to function as a good lubricant or has become contaminated beyond safe operating limits. This on-board indication to change oil or service the engine could save critical losses of operational equipment.

The AIR BITE will indicate when the air induced to the engine itself is contaminated with solid particulate matter such as dirt. Such an indication would reveal that the air induction and filtering system is not functioning properly and that continued operation under such conditions could damage the engine.

79 11 23 001

III. PROGRAM SCHEDULE

In order to achieve the objectives of the BITE program, the program schedule was established and is shown in Table 1.

TABLE 1. PROGRAM SCHEDULE FOR BITE

Program	Contract Month													
	1	2	3	4	5	6	7	8	9	10	11	12	13	14
Define Performance Specifications for BITE Devices	█													
Survey Commercial BITE Devices	█	█	█	█										
Screen Commercial BITE Devices		█	█	█										
Test Commercial BITE Devices			█	█	█	█	█							
Develop and Assemble BITE Components as Required			█	█	█	█	█							
Package BITE				█	█	█	█	█						
Test BITE				█	█	█	█	█	█					
Ship and Install BITE on Field Engines										█				
Field Test BITE										█	█	█	█	█
Complete Interim Report														█

IV. BACKGROUND

A. General Principles

In order to obtain commercial built-in test equipment, it is necessary to understand the various properties to be monitored and the factors which influence those properties. The following background will review the properties and factors to be monitored by AIR BITE and OIL BITE.

1. AIR BITE

AIR BITE is very important to reduce or prevent the premature failure of vehicle engines from excessive wear produced by ingested dust and dirt. When dust and dirt are ingested by an engine, very rapid wear occurs in the bearings, cylinders, and cam areas because the oil and dirt mix to produce an abrasive grinding fluid which normal filtration cannot adequately remedy. A BITE device is needed to monitor the air entering the operating engine and detect the presence of dust. When the concentration of dust exceeds the level expected for a properly functioning air filter system, the BITE should signal the vehicle operator that the air is dirty so that corrective action can be taken.

The fact that commercial air filters still pass some dust under normal conditions required that the BITE have a lower threshold below which it does not alarm. This normal dust level is in the range of $0.02 \text{ mg dust/ft}^3$. The AIR BITE should then be responsive to levels of 0.2 mg dust/ft^3 within a reasonable period of time. If instant signals were given at the 0.2 mg/ft^3 level, many false signals would result, reducing system reliability.

The BITE must be responsive to the wide range of dust particle sizes which can be experienced in the field. Particles less than 3 micrometers would not be considered as harmful as those in the 3 to 25 micrometers range.

2. OIL BITE

Oil quality in operating field vehicles is currently monitored by the Army Oil Analysis Program Laboratories (AOAPLABS) by sampling the lubricating oil of operational vehicles on a regularly scheduled basis and performing specific laboratory tests on those samples. The results of those tests are compared with the results from previous samples from the same vehicle and with certain guidelines and limits which aid in deciding what corrective action on which vehicles is required. This procedure is effective in preventing premature engine failure in many cases but some failures occur because of rapid degradation of oil quality caused by overstressing of the oil and the engine. Rapid failure of the oil can occur shortly after routine sampling and analysis

and severe engine damage or failure can occur before the next scheduled oil sampling.

An OIL BITE which would serve as an early-warning adjunct to the AOAP Lab analysis could save many rapid engine failures. When the oil begins to fail, an OIL BITE could indicate such failure and an unscheduled sample could be sent to the AOAP Lab for confirmation and corrective action recommendations.

Monitoring of oil quality on the fielded vehicles is a difficult task because of the several factors influencing the properties to be monitored. These properties and some of the problem factors are herein described.

a. Viscosity--A variety of problems must be considered when the lubricating oil viscosity is a criterion for its usefulness as a lubricant. The viscosity of oils supplied under MIL-L-2104C to the Army varies within a given grade because of normal specification max-min limits. As the oil temperature in the operating vehicle changes, especially during warmup, the viscosity of the oil will vary over a wide range. Different grades of lubricants are used in the vehicles depending on the climatic conditions so the use of viscosity as a criterion for vehicle lubricant quality must be carefully employed to avoid false indications.

Other factors also influence the viscosity of the oil and must be considered. Fuel dilution or erroneous introduction of oil of lower viscosity grade can reduce the oils viscosity and its ability to protect the rolling and rubbing surfaces. Oxidation thickening of the oil produced by stressing of the oil in service can increase the viscosity and limit the oils' cooling effects because of inadequate flow. Prolonged use can produce heavy soot loading and sludge buildup which can also increase the viscosity to unacceptable limits. Thus, an out-of-range viscosity measurement could indicate a variety of problems in the fielded vehicle but correlation of the measurement is difficult.

b. Acidity--Acids are produced by the combustion process and are introduced in the blow-by gases to the crankcase. Organic acids are produced by high temperature stressing of the oil. These acids deplete the alkaline additive package and corrosive wear will immediately result as soon as the acidity of

the oil reaches a point where metal attack can begin. It is very important to monitor oil acidity to avoid such corrosive wear.

c. Wear Metals--The wear metal content of an oil is an indication of wear either due to corrosion, erosion or mechanical failure of some component in which excessive wear occurs. A built-in device which would indicate such wear would be very valuable if it could indicate the rate of wear. This being very difficult, total wear metal content would be of real value in indicating unscheduled oil sampling or draining.

In reviewing these various requirements of an OIL BITE device it was apparent that there might not be any single commercial device which could meet all of these requirements. In discussions with program technical monitors, it was concluded that it was unlikely that a built-in OIL BITE device meeting all of the requirements could be located in the commercial market.

B. Potential BITE Principles

1. AIR BITE

Two major types of devices are considered applicable. One device would function by collecting dust from the induction air which has been filtered through the vehicle air filtration system. Figure 1 illustrates the filter

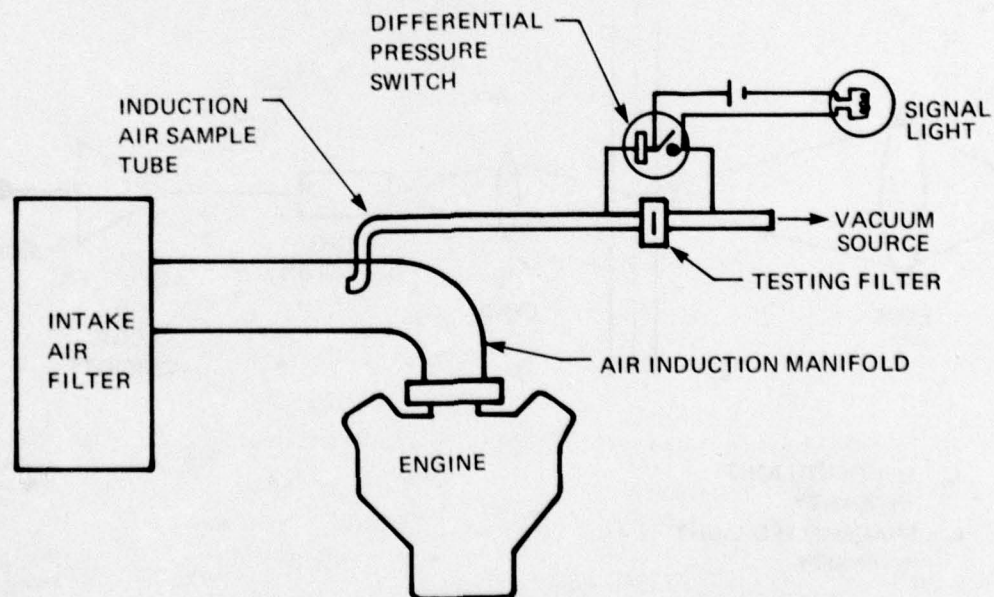
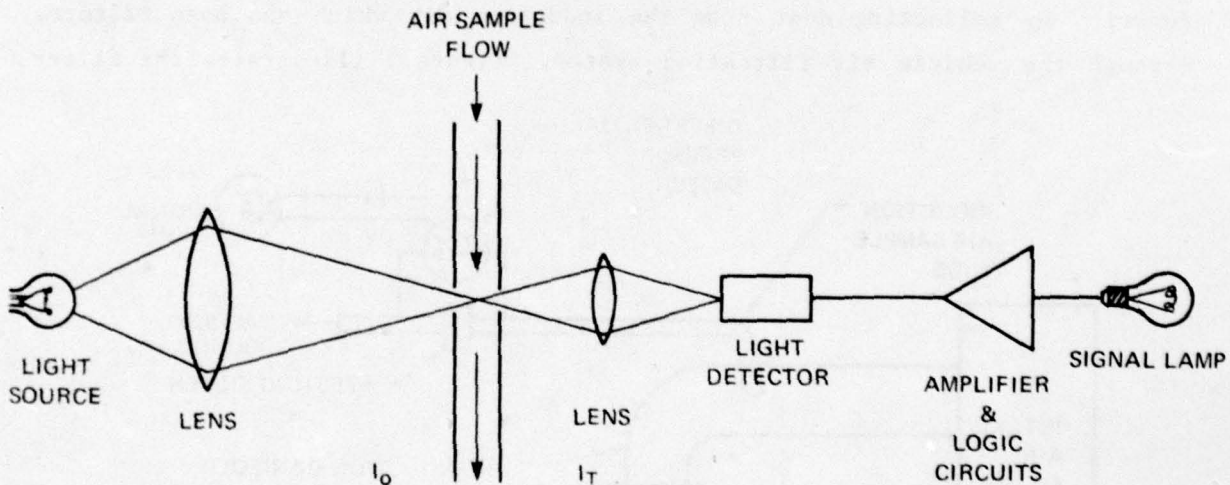

FIGURE 1. GENERAL CONCEPT OF FILTER TYPE DUST DETECTOR

type detector. This type of device would analyze the air just before it enters the engine and would determine the quantity of dust in the air. If the induction air were contaminated above a predetermined level, a failure or malfunction of the air filtration system of the vehicle would be indicated. Such a device could sample and filter the air by suction. The filter could be removed and analyzed by x-ray fluorescence or chemical analysis, or preferably, indicate the presence of dust while the vehicle is in operation without filter removal. Indication would occur if flow through the filter in the air sample line was reduced. Dust present in the sample air would slowly plug the filter, restricting the flow and the pressure differential across the sample filter would increase. When the pressure differential reached a predetermined level, a warning system would give indication to the vehicle operator that the induction air was contaminated. This type of device will be referenced in this report as the filtration type dust detector.

A second type of analytical device would be one in which the induction air would be examined for dust and dirt particles by optical light scattering. Several different types are described as follows:

Direct light obscuration is the reduction in the transmittance of an optical light path because of the dust present. Figure 2 illustrates this principle.



I_0 = INCIDENT LIGHT
INTENSITY
 I_T = TRANSMITTED LIGHT
INTENSITY

$I_T < I_0$ BECAUSE OF LIGHT SCATTERING AND ABSORPTION BY DUST PARTICLES

FIGURE 2. OPTICAL DUST DETECTOR BASED ON LIGHT OBSCURATION

The dust particles absorb the light or scatter it away, preventing it from reaching the detector. This system might be relatively insensitive to the levels of dust in the filtered air and only the higher levels might be indicated.

Another type of optical dust detector employs light scattering with a number of variations. Figures 3a, 3b, and 3c show the differences. Either right angle, forward or reverse light scattering could have potential as a dust detector. Right angle scattering measures the amount of light scattered at right angles to the incident light beam. The intensity of the scattered light is proportional to the concentration of particles in the beam. Forward and reverse scattering measure the light scattered into a shadowed area of the beam. All light scattering methods are particle-size dependent.

Another concept employs an impingement process. Air is impinged upon a surface, which serves as a reflector in an optical system. As the amount of dust on the reflecting surface increases, additional scattering occurs, reducing the optical quality of the reflective surface. This device is an integrating light transmission dust detector. It would require cleaning or complete replacement once the surface became sufficiently loaded with dust. Figure 4 illustrates this principle.

2. OIL BITE

There are no clear-cut testing devices which can monitor all of the previously mentioned properties of lubricating oil, take into consideration each of the factors influencing the oil quality and give an indication of which factors are adversely affecting the oil quality at any given time. There are many claims made for some devices but these claims are not supported by sound technical data. There are some systems that do offer technically feasible approaches and were considered in this program.

a. Viscosity--Several techniques are possible for monitoring viscosity. In most cases, the measurement must be physical. The vibrating reed electrometer viscometer can be used to measure viscosity on-line. This device measures the fluid's resistance to the vibration of a pulsed reed suspended in the fluid. This device is somewhat delicate and quite expensive for military vehicle application.

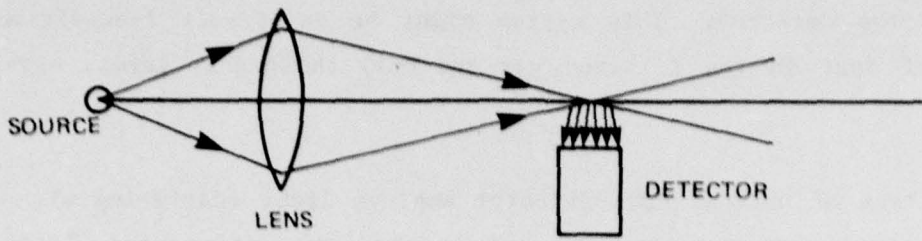

FIGURE 3a. RIGHT ANGLE LIGHT SCATTERING DUST DETECTOR

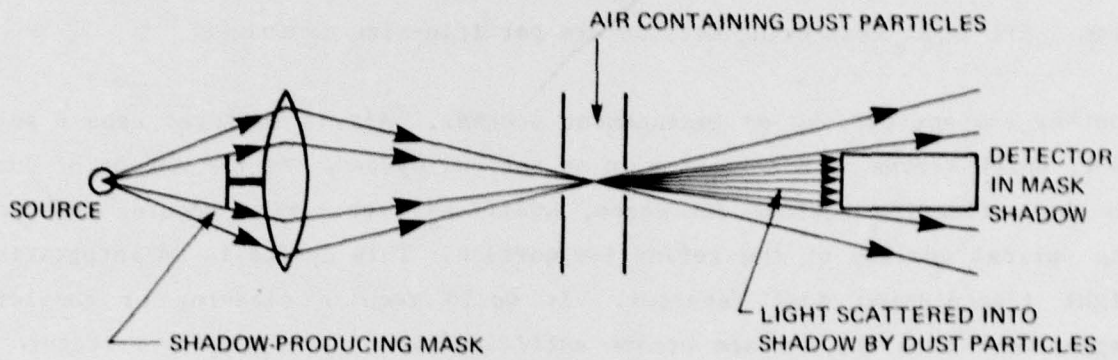

FIGURE 3b. FORWARD LIGHT SCATTERING DUST DETECTOR

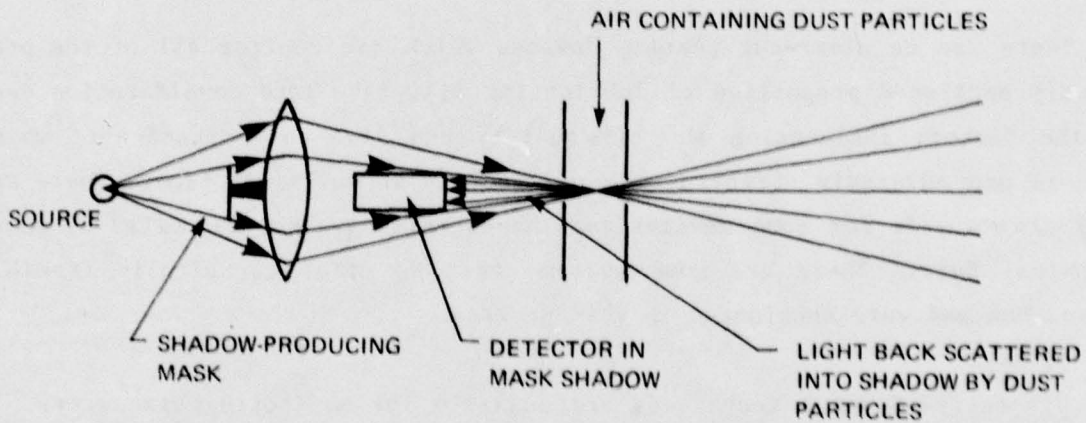

FIGURE 3c. REVERSE LIGHT SCATTERING DUST DETECTOR

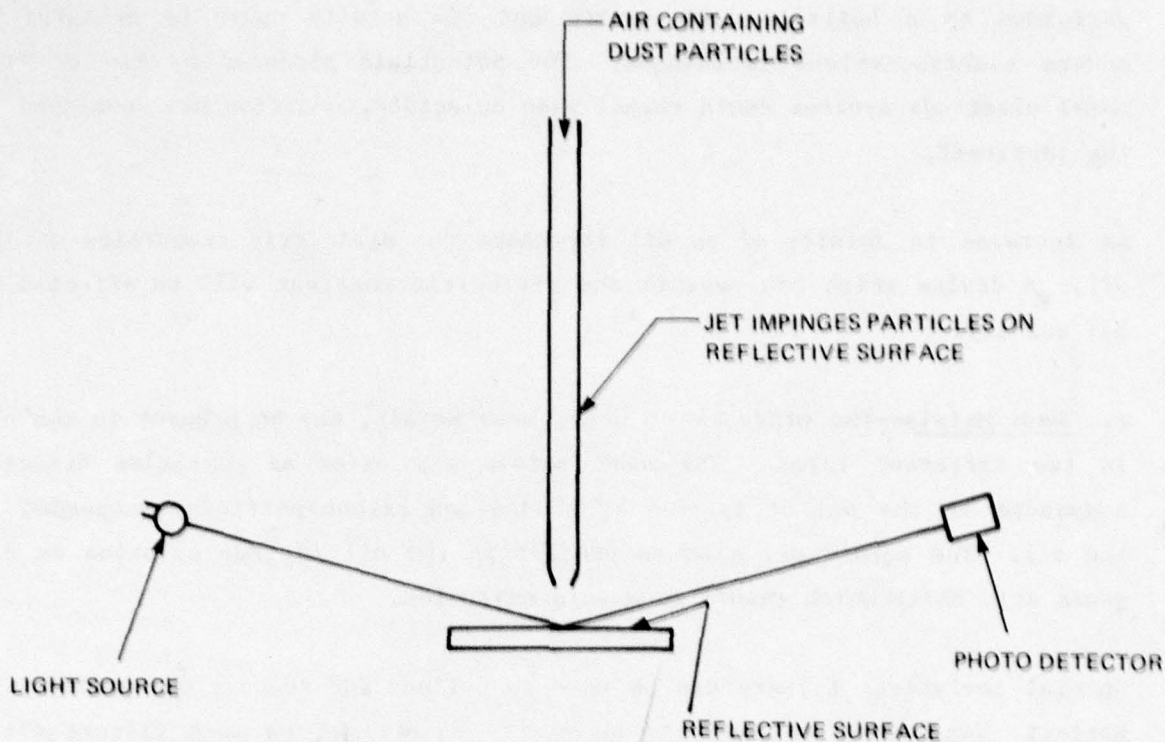

FIGURE 4. IMPINGER-OPTICAL REFLECTION TYPE DUST DETECTOR

The differential pressure across an orifice has potential as a viscosity measuring device. The pressure differential manifests itself in two ways. The pressure can be read directly or, with limit controls, trigger an alarm, or the pressure can displace a force-loaded piston in a precision tolerance cylinder and the displacement can be monitored.

The dielectric properties of an oil are a function of viscosity and the various factors which affect viscosity also affect the dielectric properties. This phenomenon, although not fully understood because of the many complexities, has been reported to be a useful technique for monitoring oil viscosity.

b. Acidity--Since the oil acidity produces no direct major physical property change, it is necessary to measure acidity by an electrical or electrochemical method. In order to measure acidity in the laboratory, the oil must be dissolved in a solvent containing a small amount of water so that the hydrogen ion sensitive glass electrode can measure the hydrogen ion concentration. The solution is normally reacted with standardized alkali to determine the amount of acid present in the oil. This involved procedure obviously cannot be

performed by a built-in test device but oil acidity could be measured by modern electrochemical techniques. The potentials produced by bi- or tri-metal electrode systems could reveal when an acidic condition has developed in the lubricant.

An increase in acidity of an oil increases the dielectric properties of the oil. A device which can measure the dielectric constant will be affected by oil acidity.

c. Wear Metals--The products of wear, wear metals, may be present in the oil in two different forms. The wear metals may exist as particles directly suspended in the oil or carried by sludge and carbon particles suspended in the oil. The metals may also be present in the oil in true solution as organic acid salts which result from acid corrosion.

Special analytical filters can be used to collect and recover the particulate matter. Wear metal content can be easily determined on such filters after their removal from the system. Either x-ray analysis or colorimetric chemical analysis can determine metallic elements on filters. Iron, the principal wear metal, is especially easy to detect. However, this technique does not determine the wear metals in true solution since they are not recoverable on filters.

The wear metals cause an increase in the dielectric properties of an oil. Particles can cause an erratic or unstable dielectric response because of the nonhomogeneity of the system.

Since dielectric properties respond to viscosity affected by sludge, solids, acidity and wear metals, a device measuring dielectric constant was considered to show real potential for oil monitoring. Previous experiments with dielectric constant measurements have indicated that overall oil quality could be correlated but not directly to the specific properties of viscosity, acidity, or wear metals. Dielectric properties are affected by the net of all of these factors.

V. COMMERCIAL BITE SURVEY

A summary of projected purchase volumes was required to present information to the potential suppliers. A search of the literature for commercial devices which might meet the requirements of the program was conducted and the suppliers were contacted to determine interest and potential. The literature provided names of organizations which might be potential suppliers of BITE devices. A presentation was prepared to brief the potential suppliers on the objectives, testing and procurement schedule of the OIL and AIR BITE program. The viewgraph presentation is shown in Appendix A. The suppliers were personally visited and briefing sessions with senior engineers and marketing management were held. Each company was given the option of participating in AIR BITE, OIL BITE, or both. The briefings also provided the opportunity for SWRI personnel to evaluate the companies' approaches, facilities, and capabilities to supply and support a BITE item. The companies visited are as follows:

Beckman Instruments, Inc., Fullerton, CA
Donaldson Company, Inc., Minneapolis, MN
Hamilton Standard, Hartford, CN
Harry Diamond Laboratories, U.S. Army, Silver Springs, MD
Kevex Corp., Foster City, CA
Norcross Corp., Newton, MA
Northern Instruments, Inc., Lino Lakes, MN
Pall Corporation, Glen Cove, L.I., NY
Pitchford Scientific Instruments, Canonsburg, PA
Princeton Gamma-Tech, Princeton, NJ
Royco, Inc., Menlo Park, CA
Technical Development Co, (TEDECO), Glenolden, PA
Texas Instruments, Inc., Attleboro, MA

Several smoke detector manufacturers were contacted for AIR BITE. Some of the commercially available smoke detectors have potential as dust detectors because they are optical in design, but no manufacturer was interested in participating in the AIR BITE program because of the relatively low volume of devices which would be purchased by the Army. The manufacturers require sales

in excess of 5 to 10 million units per year to have interest in a new product such as AIR BITE.

The briefing sessions were held with key engineering personnel to outline the purposes, objectives, time frame, and the problem areas involved in the BITE program. The details of the program to be conducted were outlined and discussed with the marketing management and engineering personnel. After allowing one to two weeks for consideration, marketing management was contacted by telephone to determine the level of interest of the potential supplier for BITE devices. The companies contacted and the technical potential are described below.

Beckman Instruments, a manufacturer of optical, electronic and mechanical laboratory and process instrumentation, was contacted with hope that they would participate in both the OIL and the AIR BITE programs. Beckman manufactures analytical process instrumentation for the continuous monitoring of pH and waste water treatment. They also manufacture optical instrumentation for the measurement of turbidity and spectral absorption. Beckman indicated an interest in the program but they had nothing which could be modified or adapted into a BITE device. After reviewing the program it became apparent that they did not have a viable candidate for the BITE program.

Donaldson manufactures air filters and air filtration systems for heavy equipment. They have designed, developed, tested, and marketed a filter-type dust detector with differential pressure indication. The marketed device appears to meet the needs of the AIR BITE phase. Donaldson was enthusiastic and supportive. A test program was outlined for testing the detector in the Donaldson laboratories under contractor supervision.

The U.S. Army's Harry Diamond Laboratories specializes in the manufacture and design of fluidic devices. Harry Diamond Laboratories suggested using fluidic analyzers to monitor viscosity. Oil samples which exhibit the range of viscosity in question would be required for testing.

The Kevex Corporation manufactures radioisotope and tube excited energy dispersive x-ray fluorescence analyzers. It was possible that Kevex could pro-

duce a very low cost along side the vehicle OIL BITE device for the analysis of wear metals. Upon review it was apparent that Kevex could not meet the cost requirements. Most of their test equipment costs in excess of \$10,000. Cost and the limited application of wear metals only did not fit the objectives of the BITE program.

Norcross Corporation manufactures viscosity monitoring equipment for chemical plants and oil refineries. They described their viscosity monitor as employing a piston displacement principle with proximity sensing detectors. The problems in OIL BITE interested the engineers at Norcross and they were anxious to develop a viscosity monitoring device, but such a development program would exceed the time frame of the BITE program. Norcross chose not to try to meet the time frame of the BITE program but to independently develop, manufacture, and market a device which would meet this need. The Norcross device would not wholly satisfy the requirements of the BITE program because it would only measure changes in viscosity.

Northern Instruments manufactures handheld oil monitors which determine the dielectric constant of the oil. One monitor, "Lubrisensor," has shown promise of indicating overall oil quality because the dielectric constant of lubricating oil is influenced by the presence of fuel, sludge, acids, and wear metals. The device does not specifically indicate which of the contaminants are present but the overall quality of the oil appears to be related to the dielectric constant. Northern has recently miniaturized and simplified the Lubrisensor. The mini version is called "LUBESAFE." The potential of LUBESAFE serving as an along-side-the-vehicle tester to support the OIL BITE phase of the program appears good. Northern Instruments was very interested in participating in the OIL BITE phase and has long term plans for the development, testing, and production of an actual built-in tester for engine mounting.

Pall Corporation was interested in OIL BITE and AIR BITE but did not have instrumentation or immediate solutions to the problems. Pall manufactures filters for air and fluids used in the aircraft industry.

Recovery of contaminants and subsequent analysis was a suggested approach. Recovery of materials for later testing and analysis is an excellent research tool but was not practical for the immediate indication required by BITE.

Pitchford Instrument Company manufactures x-ray analyzers. They offered an along-side-the-vehicle x-ray analyzer for the analysis of recovered filters. Such analyses would be helpful but would not really meet the cost or built-in requirements.

Similarly, Princeton Gamma-Tech manufactures x-ray analyzers. Princeton Gamma-Tech and Pall were willing to work together to produce an analytical filtration system. This type of oil monitoring would be conducted from a van or truck housing the equipment, power supplies and the maintenance and service hardware. This approach was outside the overall objectives of OIL BITE.

Royco manufactures optical particle counting equipment and expressed a sincere interest in both the OIL and the AIR BITE. After reviewing the program and discussing the problems inherent in OIL BITE, Royco decided that they would not participate in the OIL BITE phase. However, the AIR BITE program showed significant potential. Royco manufactures particle counting equipment for clean rooms and believes modification of some of their existing hardware would meet the AIR BITE requirements.

Tedeco (Technical Development Company) presently manufactures chip detectors for the lubricating systems of turbine engine aircraft. They also manufacture a variety of other optical and electronic devices for aircraft oil and fuel systems. Tedeco could offer a magnetic type chip detector to indicate the accumulation of magnetic wear debris. This limited device for OIL BITE does not meet the full requirements for oil quality. Tedeco probably would not be a supplier for OIL BITE.

Texas Instruments was preparing to market a device to detect corrosive or acid coolant in water jacketed engines. This corrosion monitor has long range potential as an oil corrosion (acidity) monitor but was originally designed for water systems. Modifications would be required to operate properly in lubricating oils. Texas Instruments was interested in OIL BITE and wanted oil

samples from field applications and operations for testing their device. Arrangements were made to provide the necessary samples for laboratory testing.

Prior to the actual testing of potential BITE candidates, TARCOM personnel visited, reviewed, and planned the program activities. The BITE phase was discussed in detail, including respondents approaches to meeting program requirements. Overall, the response from industry and approaches available to meet AIR BITE objectives were considered good. The OIL BITE response was limited and not completely problem-solving because of the complexity of the multi-faceted objectives desired. Table 2 lists the potential suppliers for follow-up consideration. The first three were considered prime prospects. The other four were to be considered as long term alternate suppliers.

TABLE 2. POTENTIAL SUPPLIERS

<u>Potential Supplier</u>	<u>Type BITE</u>
Donaldson	AIR (Filter Type)
Royco	AIR (Optical)
Northern	OIL (Dielect.)
Texas Inst.	OIL (Acidity)
Tedeco	OIL (Mag. Chip)
Pall	OIL (Diagnos. Filt.)
Norcross	OIL (Viscosity)

In summary, the briefing and planning phases produced three prime candidates. The Donaldson filter-type Dust Detector, a Royco optical dust detector and Northern Instruments' Lube-Safe handheld oil monitor offered the best promise. After review of the overall objectives, these three candidates were selected for more extensive and immediate testing. Royco promptly began development on a prototype optical dust detector which could be bench tested, modified, and field tested. The Donaldson dust detector was scheduled for bench testing at Donaldson. Details of this testing will be given in the following section. A Northern Instruments LUBESAFE was purchased for lab tests and comparison with the larger Lubrisensor.

VI. LABORATORY TEST PROGRAM

A. AIR BITE

Donaldson--Tentative test plans were made with Donaldson to establish sensitivity and total contaminants level at which the Donaldson Dust Detector signals contamination. Tests were run at Donaldson under AFLRL staff supervision. This equipment had been commercialized and was well researched and tested.

The device has been on the commercial market for two years and has met with considerable success. This commercially-available device was tested for repeatability, sensitivity, and response time. Donaldson Bull. No. P45-7649 is found in Appendix B and illustrates the detector and its position relative to the intake manifold or turbocharger inlet.

Test conditions were calculated based on the air flow rates expected in M60 and M113 vehicles. The dust detectors would be required to function from idle speed to full throttle in low and heavy dust environments. It was decided to test at near full throttle conditions when heaviest dust conditions could be expected. This corresponds to 675 SCFM for the Detroit Diesel 6V53 powered M113 and 980 SCFM for the 6V53T. The M60 has two air induction systems, one for each bank of six cylinders and the maximum air flow expected in each system is 600 SCFM. The 900 SCFM was chosen as the test condition maximum.

Dust levels during the test were difficult to select and control, especially at low concentrations. The dust to be used was AC Fine Test Dust, an industry standard. The efficiency of the air filters for either the M60 or the M113 is about 99% for new filters. As the filters become dirt-laden, the efficiency rapidly rises to approximately 99.9%. Dust-filled air is considered zero visibility at 25 mg dust/SCF. Thus a new air filter in zero visibility dust could pass dust at the 0.25 mg/SCF level initially and still be functioning properly. Of course, at these levels, the filter will quickly load and become much more efficient, reducing the amount of dust passed.

However, it is the total amount of dust the engine ingests that does the damage and not the momentary high concentrations or pulses of short duration. It was decided to test at various dust levels and determine the length of time required for indication of dust at each level and the total quantity of dust ingested at each level. The level of 0.39 mg/SCF was the lowest level that could be continuously fed and was 56% higher than the expected levels of 0.25 mg/SCF for a new filter in worst dust conditions.

The test facilities were capable of operating under controlled flow rate, controlled dust feed rate and absolute filtration. The dust tunnel was approximately 12 feet long with a 3 feet diameter absolute filter. Special controls held the air flow at the present selected value. The tunnel was operated at 918 SCFM of intake air and AC Fine Test Dust was fed to the air intake from a rotary table variable speed feeder. Times were measured for detection and total dust ingested was determined by weight increase of the absolute filter in the dust tunnel. The device was found to be repeatable at a given dust concentration. At the 0.39 mg/SCF concentration level, the response varied within 6% of the mean. It was found that at higher dust ingestion rates, the sensitivity increases, thus warning of dust even more quickly. Table 3 summarizes these data.

TABLE 3
DETECTION LEVELS OF
DONALDSON DUST DETECTOR

<u>Concentration of Dust in Air Intake, mg/SCF</u>	<u>Total Dust Ingested Before Signal, g</u>
0.39	2.3
1.2	2.9
1.7	3.0
2.6	2.9
4.5	1.7
7.6	1.7
11.4	1.7

The sensitivity of the detector can be easily varied by the manufacturer. One run was conducted, where, by tripling the diameter of one orifice in the sensor cell, the sensitivity was decreased by a factor of 9. From this single run, the sensitivity appears to vary inversely to the area of exposed filter. Figure 5 illustrates the sensor cell and the arrow indicates the orifice to be changed if sensitivity changes are required.

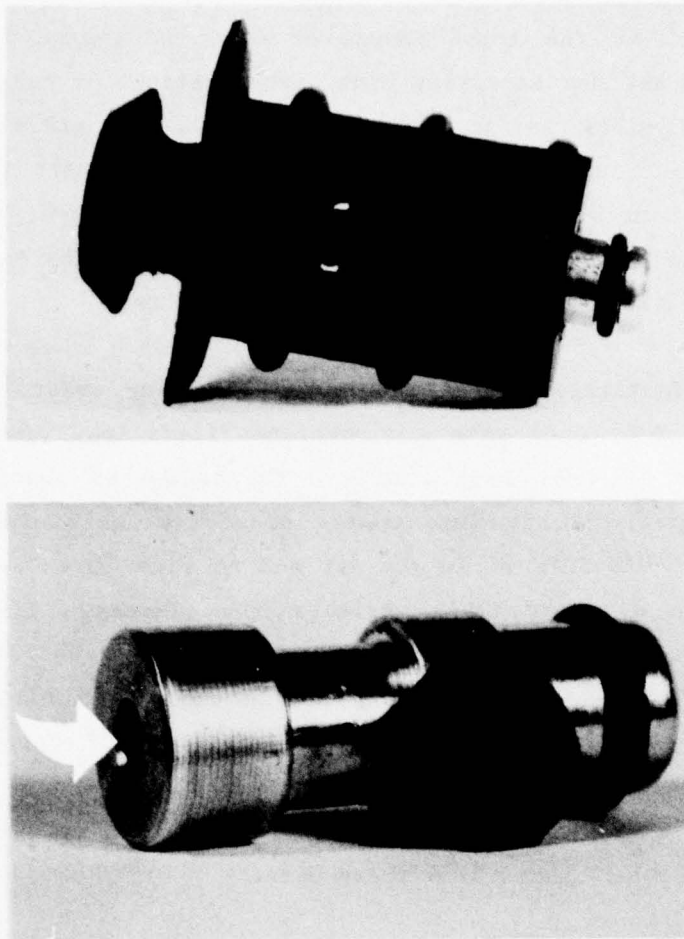

FIGURE 5. SENSOR FOR DONALDSON DUST DETECTOR

Figure 6 shows elapsed time before indication (ETBI) as a function of dust concentration. From this figure, it can be seen that the ETBI of the detector decreases as the dust concentration increases and, in high dust conditions, was less than 10 seconds.

In conclusion, this detector by DONALDSON is effective and sensitive. It was recommended for field-testing.

Royco--Royco had developed a prototype optical dust detector ready for testing. Royco was visited and the bench model optical dust sensor was examined and tested. The device operated on the forward light scattering principle. See Figure 3b. The device contained an incandescent light source, a plastic focusing lens and a photodiode sensor all mounted on an optical bench

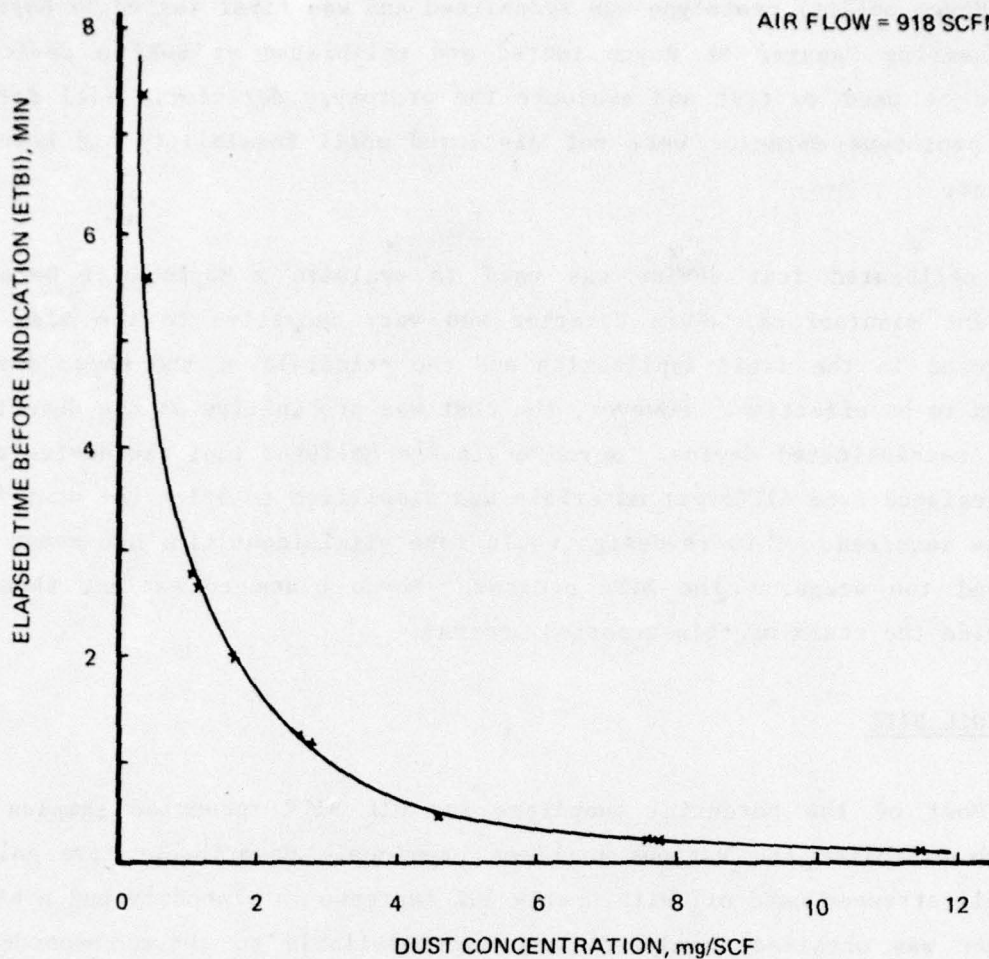

FIGURE 6. RESPONSE TIME OF DONALDSON DUST DETECTOR

with appropriate light shields, baffles, and masks. The device was extremely sensitive and the 1- to 40-mv output was used to trigger the alarm indicator. Royco supplied a prototype for testing at SwRI. Test facilities at SwRI were scheduled and arranged for measuring the sensitivity range and repeatability of the device following inspection and training at Royco.

The device was very responsive to small particle dust in air. However, the dust to be detected is of larger particle size than 10 micrometer and the detector lacked adequate sensitivity to these particles. A response of 7 mv for concentrations of 2 mg/SCF was typical. Noise levels and drift were of the order of 1 mv. The chief engineer of Royco indicated that a right angle scattering device would be more likely to provide the increased sensitivity of 10 mv for 0.05 mg dust/SCF required. The right angle device would probably be more simple in design, lower in cost and easier to install.

The Royco optical prototype was redesigned and was first tested by Royco. The Engineering Manager of Royco tested and calibrated at SwRI a device which would be used to test and evaluate the prototype detector. Full details of the prototype detector were not disclosed until feasibility had been established.

The calibrated test device was used to evaluate a Royco Dust Detector in current manufacture. This detector was very sensitive to the size of dust expected in the field application and the principle of the Royco device was shown to be effective. However, the cost was prohibitive as the detector is a very sophisticated device. Royco engineers believed that the device could be re-designed from different materials and simplified to bring the cost into the range required. This re-design would take significant time and money and was beyond the scope of the BITE program. Royco plans to explore those areas outside the realm of this reported program.

B. OIL BITE

Most of the potential suppliers for OIL BITE requested samples of oil which exhibited the various problems previously described. Five gallons of highly stressed used oil with nearly 50% increase in viscosity and a high acid number was obtained, analyzed, and made available to those respondents requesting a test sample. Norcross, Northern Instruments, and Texas Instruments received samples. An additional sample containing high wear metals was also provided to Northern, Pall and Tedeco.

The results and responses from the potential suppliers are described as follows:

Northern Instruments--The along-side-the-vehicle oil tester marketed by Northern Instruments Co. was lab evaluated and its performance is similar to the larger, more sophisticated model from the same manufacturer. The larger model had been under test at AFLRL for two years and had correlated satisfactorily with engine condition and chemical laboratory tests. The device measures the dielectric properties of the lubricant. The dielectric constant increases as oil contamination from soot, sludge, acid buildup and wear metals increases.

Diesel fuel dilution causes an increase in dielectric constant but gasoline causes a decrease. Oxidation of the oil also causes dielectric constant increase. Erratic meter readings (needle fluctuation) are indicative of lube contamination from a glycol coolant leak to the oil. The device does not distinguish which property is changing, merely that the quality of the oil is decreasing. Appendix C shows the operating manual of LUBESAFE.

After careful examination of the LUBESAFE, both at the manufacturer's plant and SwRI, and after comparison with the previously tested Lubrisensor, the tester was used to test a series of selected oil samples. In every case, where the oil was contaminated or stressed to a severe level, the Lube-Safe, like its sister instrument, Lubrisensor, indicated a failure case. Based on these results, additional units were recommended for field testing.

Texas Instruments--Oil samples were shipped to TI for testing of the corrosion monitor. After several months, TI responded that they would not participate in the test program.

Tedeco--The chip detector was responsive to high wear metals but since the detector does not detect other factors influencing oil quality, it was not considered adequate for field testing.

Pall--Oil samples were provided to Pall, but the cost and problems of filter removal, handling and subsequent analysis were considered too great to warrant field testing.

Norcross--Oil samples were provided to aid in design of a true built-in viscosity monitor. The device could not be developed within the time frame of this program.

In summary, the Northern Instrument Lube-Safe was the only candidate which appeared to have potential for the field test phase.

VII. FIELD TEST PROGRAM

Ft. Hood was recommended as a site for the field test of the BITE devices based on the large concentration of combat vehicles and close proximity to

SwRI. The Director of Industrial Operations (DIO), Ft. Hood, was visited following initial coordination by TARCOM. SwRI briefed the DIO, FMT's and maintenance officers on the program objectives and the devices to be tested. A commitment of full cooperation was offered by Ft. Hood personnel.

A. AIR BITE

The vehicles to be employed in field test, especially for the AIR BITE, were the M60 tank and the M113 armored personnel carrier. Ft. Hood has a large number of both these vehicles in operation. Plans were made to equip four M60's and four M113's with Donaldson Dust Detectors. Figure 7 shows an M60 to be equipped with a pair of detectors. The detectors had to be mounted in the ductwork between the intake air filters and the turbocharger of the engine. This required special fabrication of duct work and hose connecting



FIGURE 7. M60 TANK WITH AIR DUCT ON FILTER BOX

flanges to securely mount the detector and retain some flexibility of the duct system. Note in the previously mentioned figure, the replaced air duct lying on the air filter box.

The flexible intake air ducts from both an M60 tank and an M113 personnel carrier were obtained for engineering review and planning for installation of the Donaldson Dust Detector. A design conference was held at Donaldson to determine the configuration of the detector-duct work assembly for both types of vehicles (M60, M113) to be included in the field test. It was decided that it would be best for Donaldson to assemble the dust detector in the duct work to simplify installation in the vehicles. The M113 system involves a section of metal duct with a "hump hose" (a flexible connector manufactured by Donaldson) as a connector on each end. The metal duct supports and contains the dust detector.

The M60 installation was somewhat more difficult since the air ducts have metal flange connectors and clamps installed as an integral part.

Donaldson personnel visited Ft. Ripley, MN to determine the precise position for locating the detectors on the M60. Donaldson also contacted the current manufacturers of the air duct and obtained the ducts directly from the factory so that Donaldson could do the custom fabrication, detector installation and testing to assure that there was no effect on sensitivity. Four single assemblies for the M113 and four dual assemblies for the M60 were obtained.

The dust detectors for the M113 were delivered to Ft. Hood. The units could not be fitted into the available space and required modification. Each unit required custom modification because of variation in the angular position of the air filter housing on each M113. Significant variation in air filter housings and installation positions is common on M113's according to shop personnel. The custom fitting required rather involved cutting and rewelding of the metal tubing which supported the dust detector to align the tube between the air filter and the air intake elbow of the engine in close enough spacing to allow hose coupling with clamps. A redesigned air intake elbow of the engine to allow direct mounting of the dust detector would provide a more favorable and simple installation location if the BITE were to become standard equipment. Figures 8 through 10 are photographs of dust detectors installed on different M113 vehicles. Note the variations required in installation for the different vehicles. Figures 11 and 12 show the location of the signal box in the operator's area of the M113.

Similar installation difficulties were encountered on the M60 because the delivered ducts were too short. Extensive modification was required to obtain a "good fit" of the duct-mounted detector in the limited space available.

Figure 13 shows how the flanged elbow required lengthening and realigning. Figure 14 shows the completed duct as modified. Figure 15 shows the duct with detector in the mounting position to the turbocharger and Figure 16 shows the accessibility of the sensor in the detector.

Now that the detectors have been installed, field usage will reveal the effectiveness of the BITE device. Data gathering by both Ft. Hood and SwRI personnel began in late June.

B. OIL BITE

The Northern Instruments Lube-Safe was selected for testing in field applications at Ft. Hood. Even though this instrument is not a built-in test device, the principle of operation showed promise and a possibility exists for



FIGURE 8. DONALDSON DUST DETECTOR INSTALLED ON M113 VEHICLE "A"

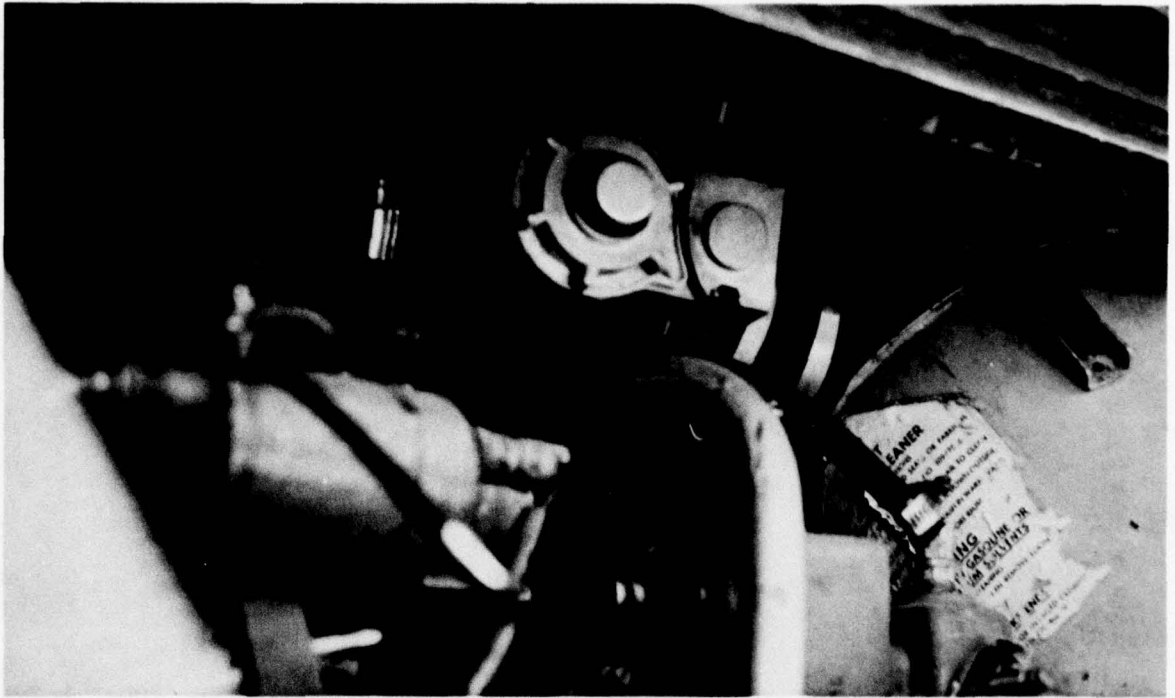

FIGURE 9. DONALDSON DUST DETECTOR INSTALLED
ON M113 VEHICLE "B" (FIRST VIEW)

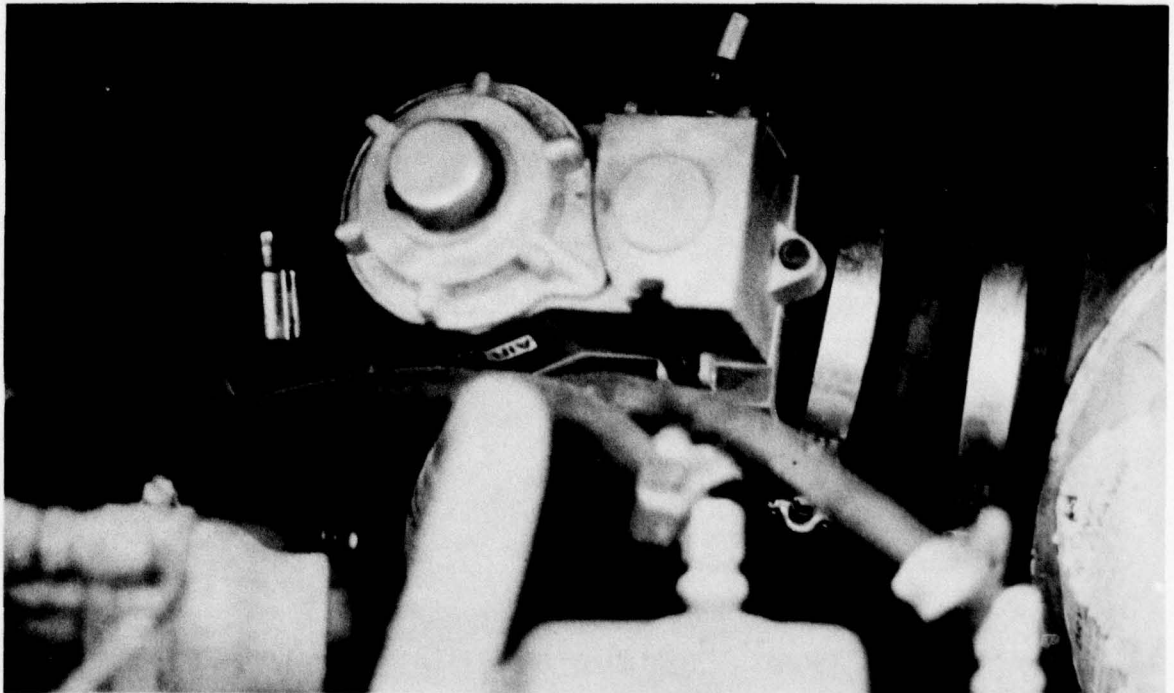

FIGURE 10. DONALDSON DUST DETECTOR INSTALLED
ON M113 VEHICLE "B" (SECOND VIEW)

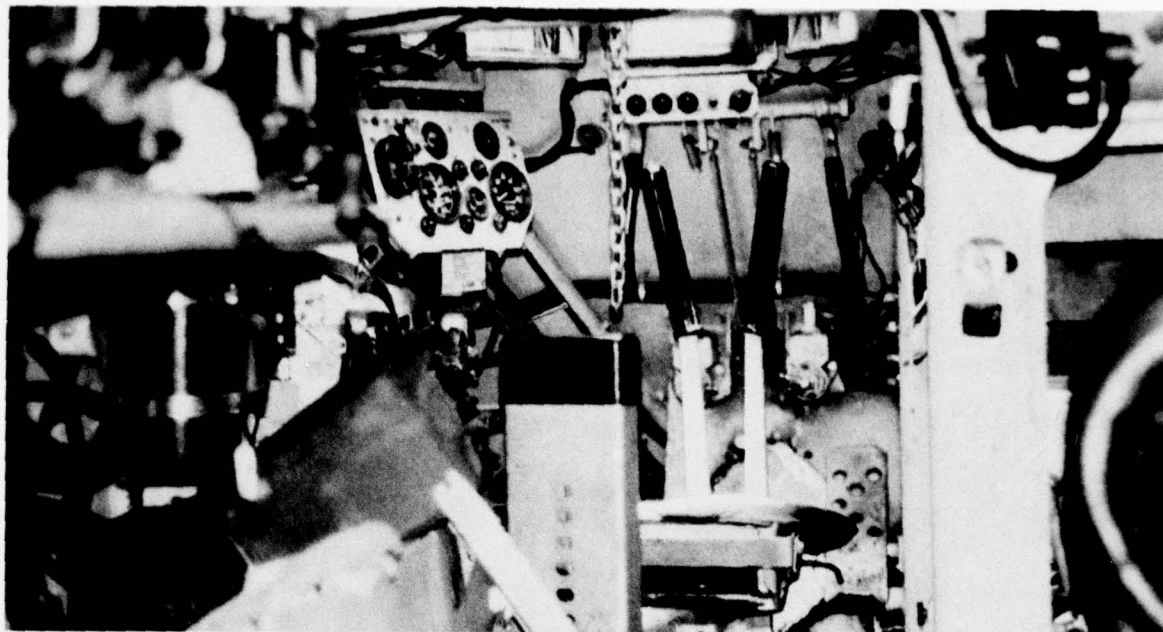

FIGURE 11. OVERALL VIEW OF M113 OPERATOR AREA WITH INSTALLED SIGNAL BOX

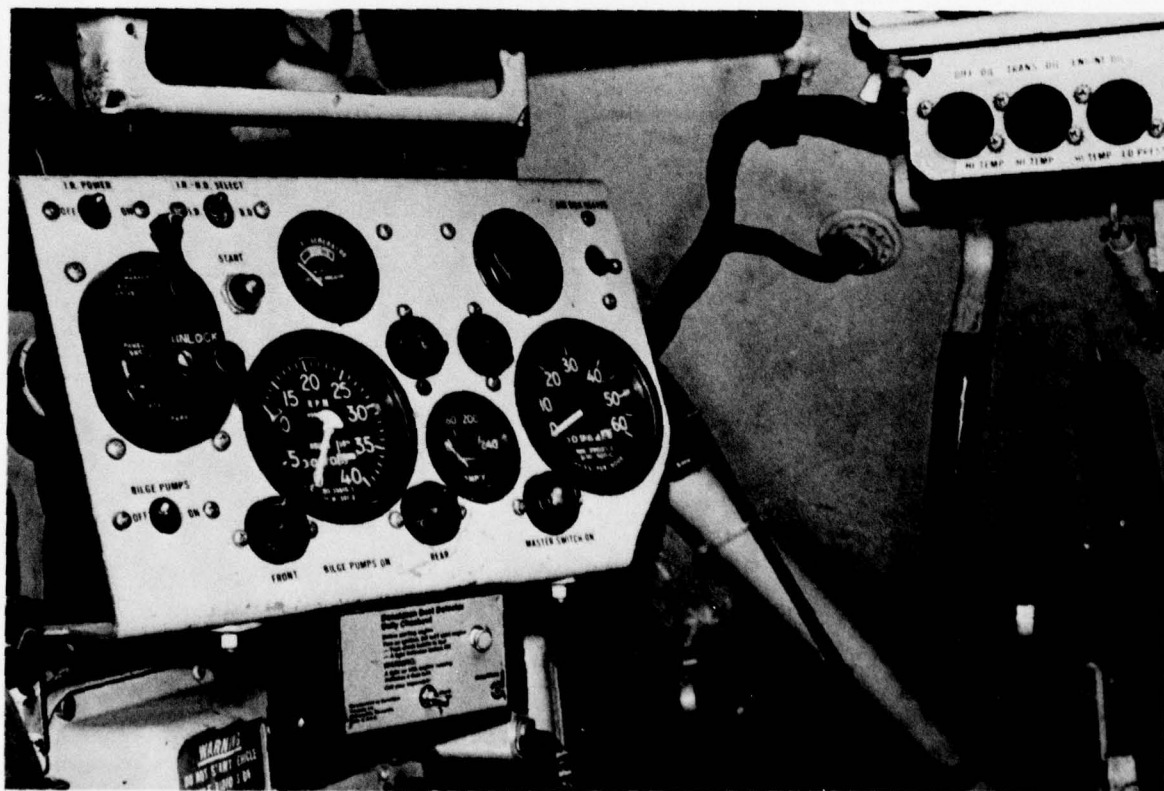

FIGURE 12. CLOSE-UP VIEW OF M113 OPERATOR AREA WITH INSTALLED SIGNAL BOX

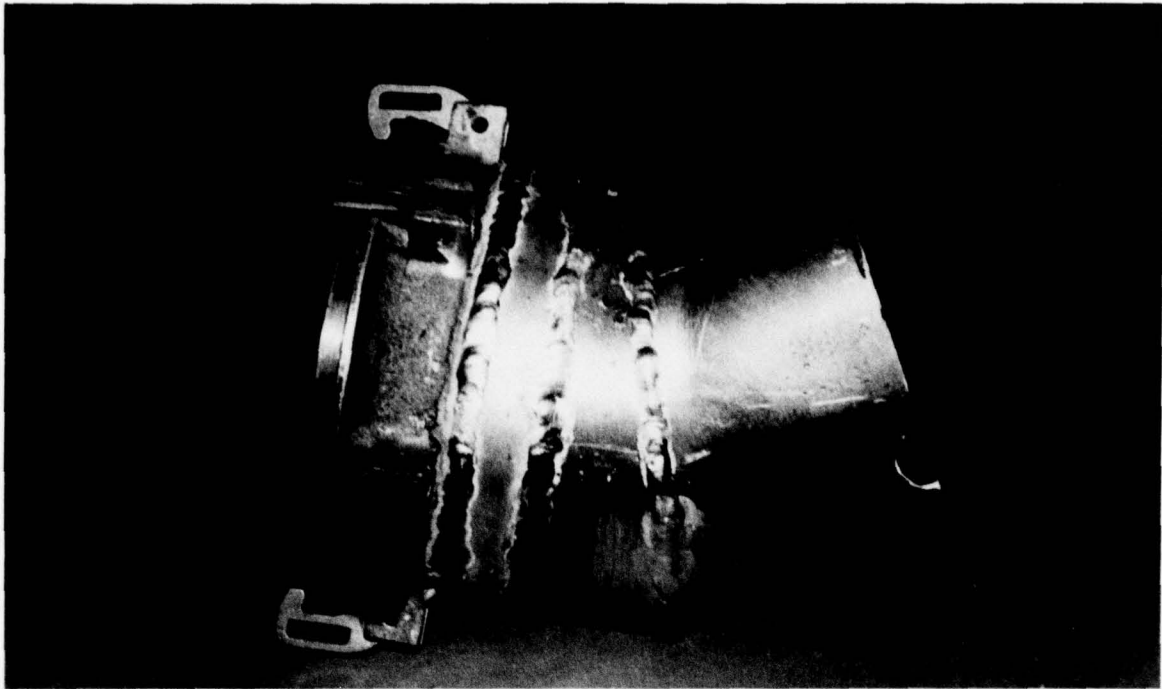

FIGURE 13. MODIFIED FLANGE AND ELBOW FOR DUST DETECTOR
INSTALLATION ON M60 VEHICLE

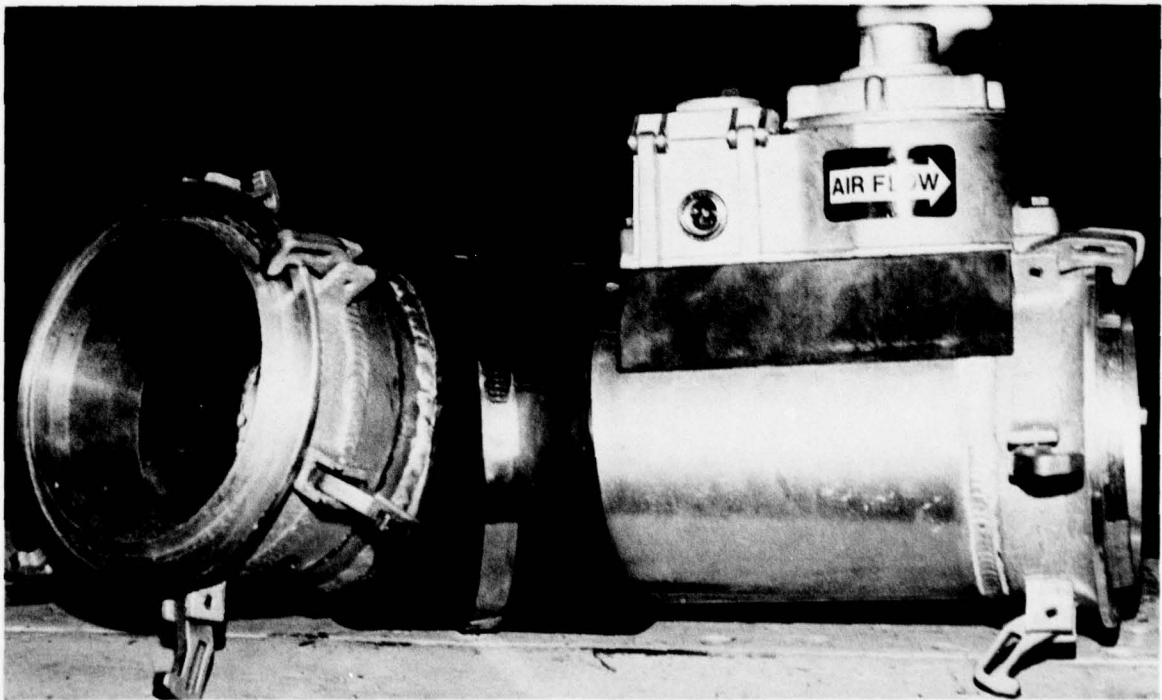

FIGURE 14. COMPLETE DUCT WITH DETECTOR FOR M60 INSTALLATION

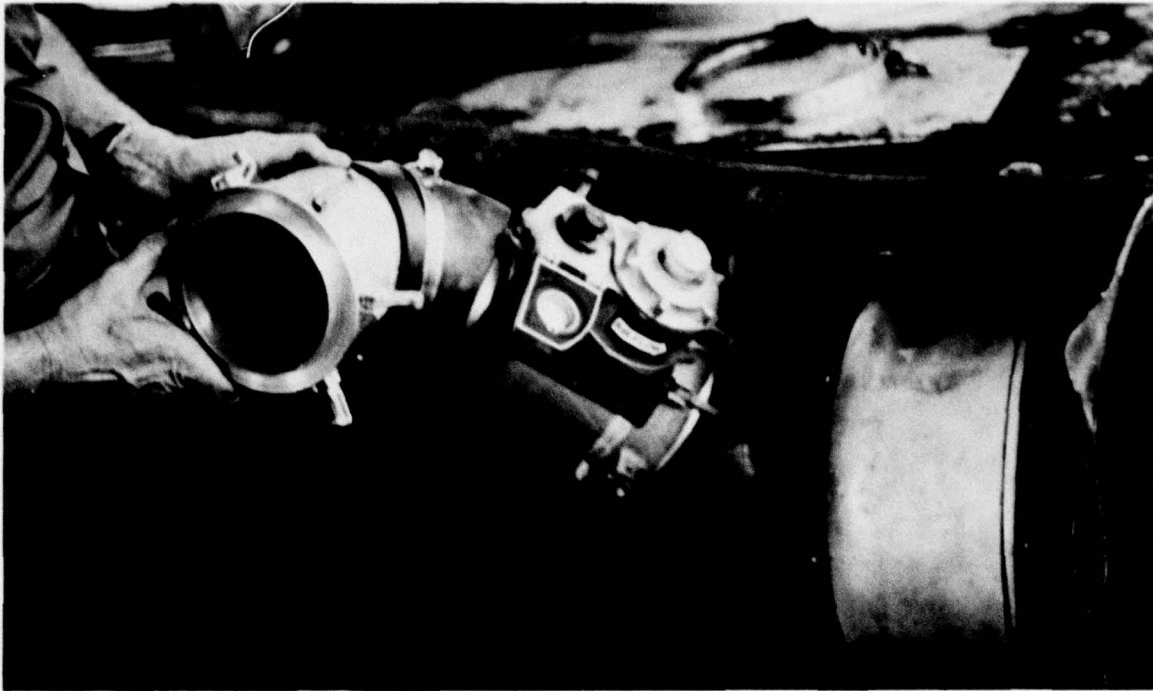

FIGURE 15. DUCT WITH DETECTOR IN THE INSTALLED POSITION ON M60 VEHICLE

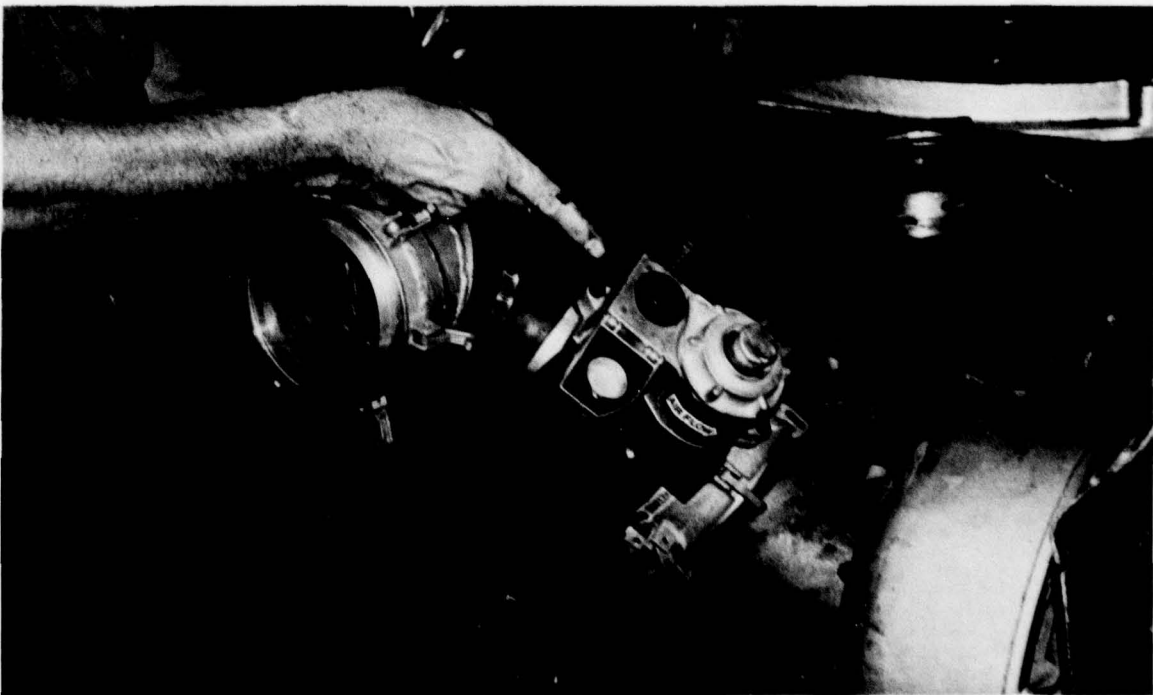

FIGURE 16. SENSOR ACCESS ON DUST DETECTOR

a built-in device in the future. In any event, the tester is intended as an AOAP adjunct and not an AOAP replacement.

Three of these testers, called Lube-Safe, were purchased and delivered to Ft. Hood for use in frequent monitoring of the vehicle oil to warn of needed unscheduled oil changes. Initially, between 200-400 vehicles were to be monitored by FMT personnel. Arrangements were made to obtain any unscheduled oil drain samples detected by the devices so that detailed laboratory data correlation of tester readings and actual oil condition could be established. Likewise, coordination with the Ft. Hood AOAP laboratory would be made to provide a third party data source since the lab monitors combat vehicle (M60, M113) lube conditions on a planned schedule.

Key personnel at Ft. Hood were trained in the use of the analyzers and began to use the units to determine the best procedure for record keeping and reporting. SwRI requested the following information: the number of tests performed and the number of unscheduled drains indicated. Once an unscheduled drain was indicated, samples of the oil were to be sent to Ft. Hood AOAP lab and SwRI for analyses. These data would provide initial baseline and after some experience had been gained in the field, firm procedures could be established.

Two additional Lube-Safe oil analyzers were ordered to serve as backup units for those in use at Ft. Hood. One of these Lube-Safe analyzers was delivered to the Ft. Hood AOAP lab to be used for data collection on miscellaneous oil samples and to serve as a backup unit. The other backup unit was retained at SwRI for similar screening purposes.

After several attempts to obtain valid data from field personnel, it was apparent that the Lube-Safe Oil Analyzer field evaluation program should be reorganized with a new test plan. In order to obtain data under carefully controlled conditions, SwRI will collect all samples, make the necessary tests and compare results with the AOAP Lab. This revised plan reduces the number of vehicles under test to 25 per analyzer. These selected vehicles will be sampled by SwRI personnel on a biweekly basis and both Lube-Safe tests and AOAP data will be carefully coordinated by SwRI personnel. The test period will be initially extended for 5 additional months to establish reliability.

VIII. INTERIM SUMMARY

In the primary phases of this program, existing commercial AIR and OIL built-in test equipment (BITE) have been reviewed for military vehicle engine application. Current and potential manufacturers of BITE devices were contacted and interviewed, after which potential AIR and OIL BITE were selected for bench testing. These tests produced results of sufficient promise to justify preliminary field evaluation. The field test has been designed to evaluate the BITE devices in actual field operations in order to experience the full range of environmental and operational conditions. The field test has been underway only a short time, and the preliminary data is inconclusive because of the small data volume.

IV. PLANS

Because several delays have been experienced in deliveries of components for AIR BITE and insufficient data collection on OIL BITE, an extension of the program to provide field data gathering in the prime dry season at Ft. Hood was requested by SwRI. The termination data for the present TARCUM contract, with associated modifications, was 19 August 1979, which did not permit adequate field data collection time. As a result of these factors, an extended contract period of performance has been authorized for 15 months.

Figure 17 depicts selected milestones which are anticipated during the 15 month extension. In projecting the planned milestones, key decision points will be provided at which time TARCUM can evaluate accumulated data, and make decisions specifying continued testing, increases in systems procurement and/or possible cancelling of phases because of system reliability, cost, maintainability, etc.

A. AIR BITE

By December 1979 the Donaldson Dust Detectors (four M60 and four M113A1) will have been under test for at least five months. The vehicles should have been used in a minimum of two field exercises at the unit level and encountered heavy caliche soil dust environment for a minimum of three months (July,

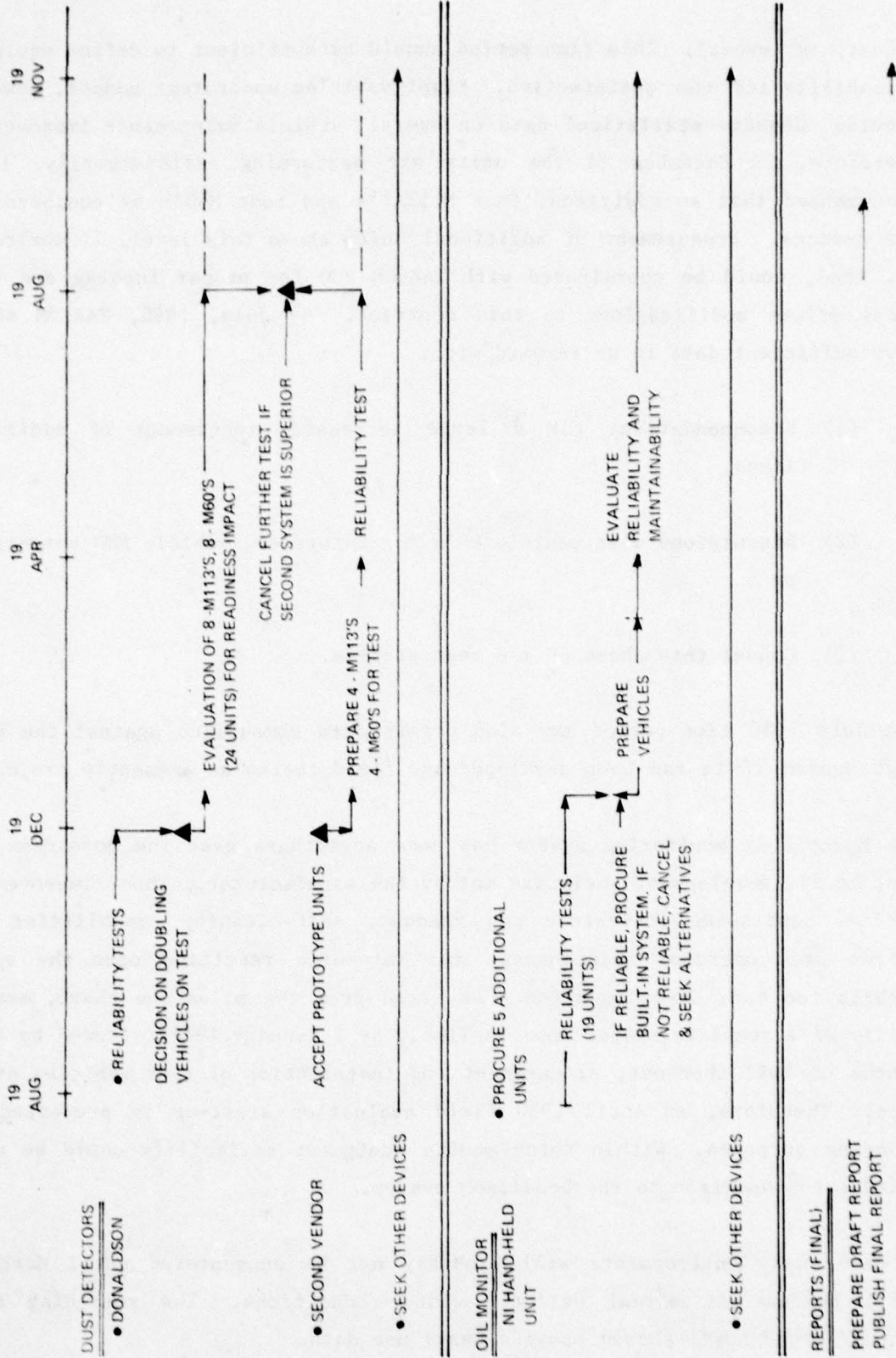

FIGURE 17. EXTENDED PROGRAM PLAN

August, September). This time period should be sufficient to define equipment reliability and user satisfaction. Eight vehicles under test cannot, however, provide adequate statistical data on overall vehicle maintenance improvement. Therefore, in December if the units are performing satisfactorily, it is recommended that an additional four M113A1's and four M60's be equipped with the devices. Procurement of additional units above this level, if desired by Ft. Hood, would be coordinated with TARCOM PCO for proper funding and technical effort modifications to this contract. By July, 1980, TARCOM should have sufficient data to go forward with:

- (1) Recommendations for a large increased procurement of additional items,
- (2) Discussions with vehicle PM's for future new vehicle MWO potentials, or
- (3) Cancel this phase of the test program.

The July 1980 time period may also permit data comparison against the Royco dust system if it has been developed and field tested as presently projected.

The Royco dust monitoring system has some advantages over the Donaldson system, if all development goals are met by the manufacturer. These improvements include continuous in-vehicle cab readout, self-cleaning capabilities (requires less operator maintenance) and automatic resetting once the system detects too much dust ingestion. As noted from the milestone chart, availability of a complete system appears likely by 1 January 1980 followed by three months of SwRI checkout, procurement and installation of test vehicles at Ft. Hood. Therefore, an April 1980 field evaluation start-up is projected for planning purposes. Within three months equipment reliability could be evaluated for comparison to the Donaldson system.

Intense dusty environments will probably not be encountered until March or April because of normal wet/cold winter conditions. The remaining three months beyond April should provide heavy use data.

Scope of Work--The scope of work for this phase is as follows:

1. Obtain and consult on installation of the dust monitoring systems.
2. Coordinate all field evaluations with appropriate Ft. Hood commands.
3. Collect and compile all necessary data.
4. Coordinate all results with Ft. Hood AOAP laboratory on oil contamination by air intake dust ingestion.
5. Conduct biweekly liaison visits to Ft. Hood to assure continuity of the program.
6. Act as a coordinator between Ft. Hood and the equipment manufacturer in solving any hardware problems.
7. Assure up-to-date review of equipment effectiveness.
8. Assure coordination and communications with TARCOM project monitors on a weekly basis by telephone.
9. Provide monthly letter reports plus interim reports.
10. Continue screening of other systems which become available on the commercial market during the proposed program time frame.

B. OIL BITE

The five Northern Instruments hand-held devices will provide a minimum of 2000 data points by December 1979 time period. If initial data looks favorable an additional five units would be suggested for purchase to assure no less than 4000 oil readings by late January 1980. By January 1980 sufficient data should be accumulated to make a sound judgement on whether or not the device can detect deteriorated oils. If the system appears to be a good "go/no-go," then the procurement of a vehicle "built-in" system may be advisable.

An OIL BITE design by Northern that can be built into the vehicle has been examined at Northern's facility. Difficulties in obtaining an etchable metal on a surface with the proper electrical and thermal properties was encountered. Joint efforts by Northern Instruments and SwRI have located a fabricator of sensor material suitable for built-in application. For the device to function properly in an engine, the substrate for the electrodes must be both chemically inert and thermally durable. One such material, aluminum oxide, has been laminated with the correct alloys and etched to produce a very precise dielectric constant measuring sensor. Northern Instruments is presently evaluating this new sensor element. If the laboratory tests of the new sensor and the field tests of the hand-held model are successful, then field testing of the built-in sensor will be conducted.

If such a procurement decision is made, the 15 month proposed contract time span would permit 6 months evaluation of the new system after vehicle installation. Should the NI device prove inaccurate or unsuitable for military use, TARCOM could redirect the program or cancel further studies early in the new contract period.

Scope of Work--The scope of work for this phase is as follows:

1. Manage the program through biweekly visits to Ft. Hood,
2. Provide detailed referee oil analysis at AFLRL on 10 samples/month, or as required,
3. Maintain data collection and compilation, and
4. Provide necessary monthly and final reports.

**APPENDIX A
PROGRAM BRIEFING**

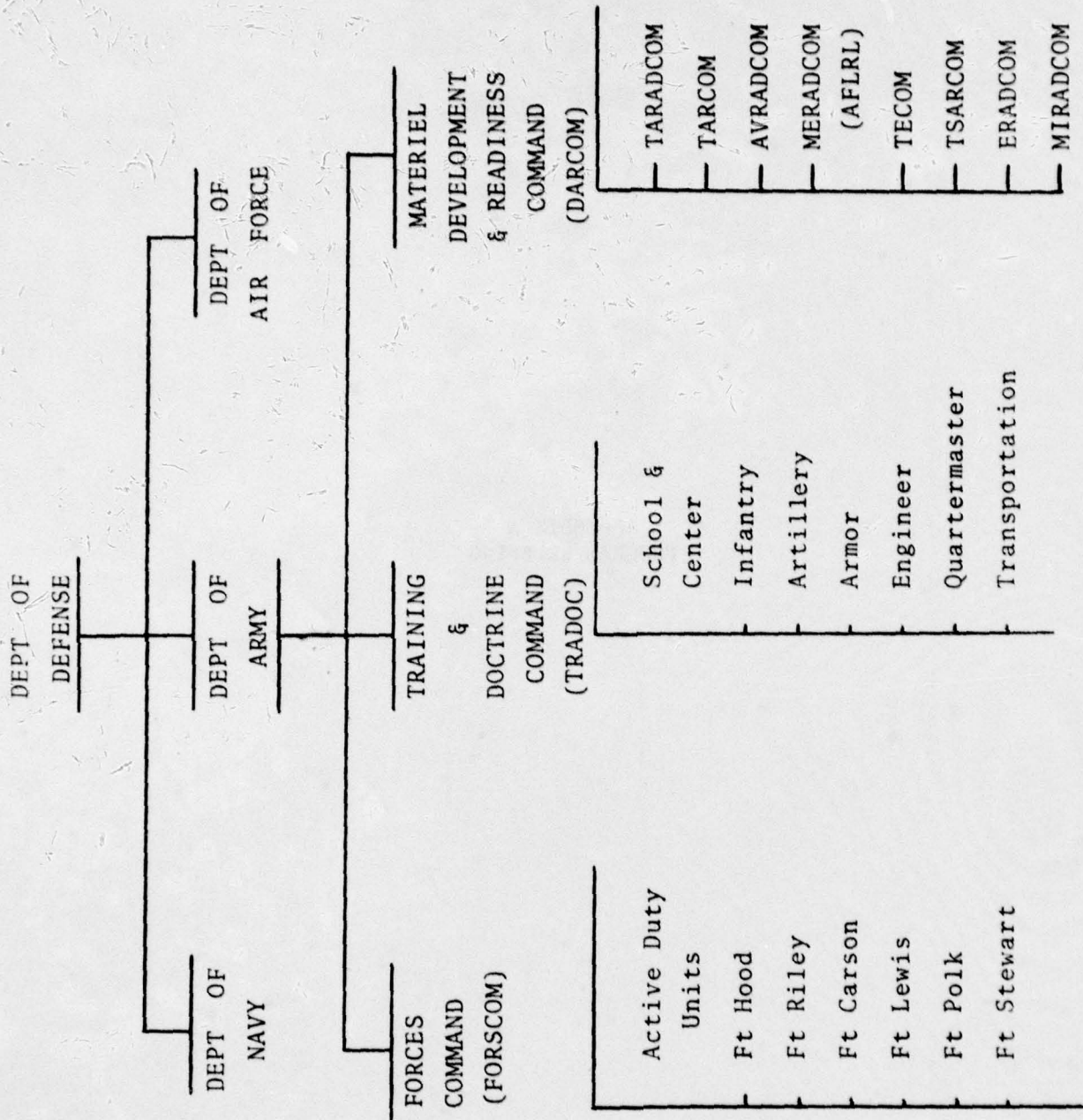

SPONSOR

U. S. ARMY

TANK - AUTOMOTIVE

READINESS COMMAND

OBJECTIVE

LOCATE / DEVELOP

COMMERCIAL

BUILT-IN TEST EQUIPMENT

BITE

EVALUATE / TEST

AND

RECOMMEND

AIR BITE

AND

OIL BITE

AIR BITE

PARAMETERS

1. DETECT DIRT IN AIR
2. SENSITIVE AT MALFUNCTION
LEVEL
3. INDICATES ON INSTRUMENT
PANEL
4. SIMPLE, LOW COST

OIL BITE

VISCOSITY

ACIDITY

WEAR RATE

VISCOSITY BITE

PROBABLY NEED 3 RANGES

SAE 10, 30, 50

TEMPERATURE CONTROLLED

-20% TO +35% OF SPECIFICATION

ON EACH RANGE

WARNING LIGHTS ON PANEL

ACIDITY BITE

INDICATE DEPLETION OF

OVERBASING ADDITIVE

INDICATE CORROSIVE CONDITION

INDICATE ACIDIC CONDITION

WEAR METALS / RATE BITE

INDICATE RATE OF WEAR

INDICATE AMOUNT OF WEAR

INDICATE TYPE OF WEAR

INDICATE MAJOR METALS FOUND

CURRENT PROGRAM

SURVEY

TEST

FIELD EVALUATE

REPORT

FUTURE FIELD PROGRAM

PROBABLY 2 YEAR DURATION
FY 80-81

SELECTED BITE
MODIFICATION & UPGRADE STAGE
SPECIFICATIONS

PROCUREMENT

FY 82 20,000 U N I T S

FY 83 - 84 55,000 U N I T S

FY 85 - 86 25,000 U N I T S

COMPLETION DATES

CURRENT PROGRAM SCHEDULE

SURVEY & SCREEN	JUNE 20, 1978
TEST & SELECT	SEPT 20, 1978
PACKAGE & FINAL TEST	NOV 20, 1978
FIELD TEST	FEB 20, 1979
FINAL REPORT	MAR 20, 1979

APPENDIX B
DONALDSON DUST DETECTOR

Mining and
Construction Operators

**Reduce downtime
and prevent
premature
engine wear!**

WARNING
A light on
with engine running
indicates a dust leak

Find dust leaks before they can harm your engine

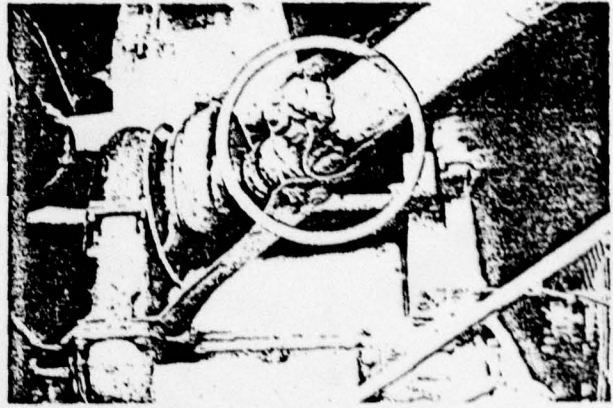
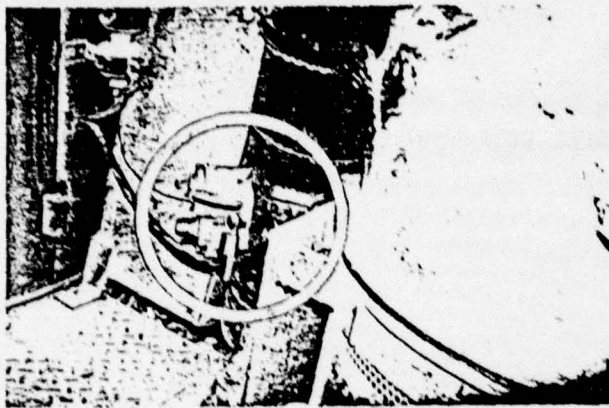

**The Donaldson Dust Detector
automatically detects gross dust leaks in
the air intake system**

Dust is an engine's worst enemy. Countless hours of downtime, premature engine wear or even an engine dust out can be the result of harmful amounts of dust entering the clean air stream to the engine. This can happen through leaky connections, holes in piping or other system faults.

Now there is a warning device available which allows early detection of air intake system dust leaks. *The new Donaldson Dust Detector.*

This innovative new safeguard, designed for use in environments where heavy dust is a problem, *continuously samples* air entering the engine. If a gross dust leak occurs, a signal light immediately alerts the machine operator.

Air passes through a replaceable dust sensor which activates the signal light when a gross dust leak occurs.

With the Donaldson Dust Detector, defects can be identified and corrected *before* abrasive dust particles have a chance to erode vital engine components or cause premature engine failure. The Dust Detector can prevent costly downtime and repairs.

The Donaldson Dust Detector is designed to be used *only* with the following air cleaners: Donaldson SRG, STG, SBG Donalcone®, STB Strata® Systems as well as Donaldson Primary Air Cleaners.

The Dust Detector is designed to be installed in straight ducts from 4" to 10" diameter that are directly ahead of the engine air intake. This location allows the Dust Detector to monitor all the connections and joints in the air intake system between the Dust Detector and the air cleaner, as well as the air cleaner itself. Refer to Bulletin P45-7649.

Dust Detector kits are available for engines with one, two or four air inlets. One signal box only is needed for each kit. The signal box is conveniently dash mounted and includes easy-to-read Daily Checkout and Warning Instructions.

Save time and money and maybe an engine — with a Donaldson Dust Detector — a MUST for all engines operating in dusty environments.

Contact your OEM or Donaldson Distributor for details.

Dust Detector Specifications

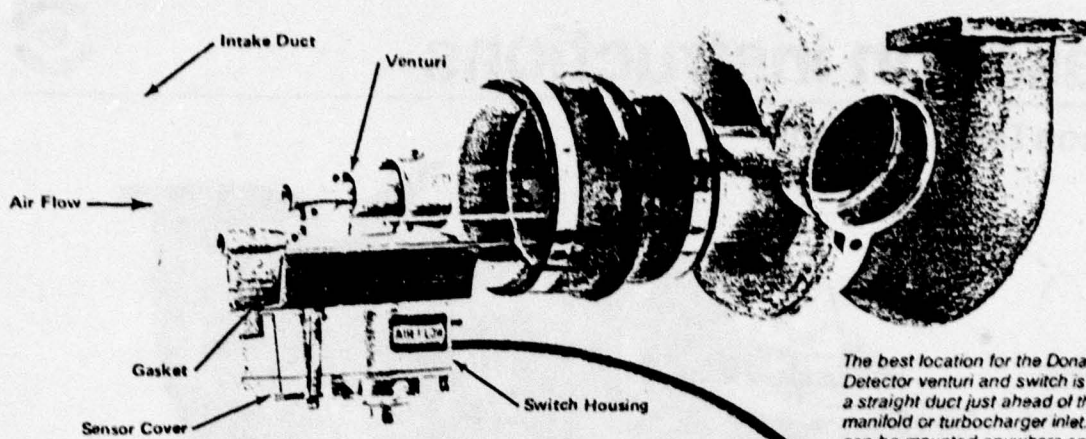

The best location for the Donaldson Dust Detector venturi and switch is in the bottom of a straight duct just ahead of the intake manifold or turbocharger inlet. The signal box can be mounted anywhere on the vehicle's dash for operator's convenience.

A complete Dust Detector Kit consists of the venturi with gaskets and switch housing, dust sensor, cable assembly and signal box, mounting template and all nuts and bolts necessary for the installation. Kits also include Bulletin P45-7649, complete Installation Instructions, Trouble Shooting Guide and Service Instructions.

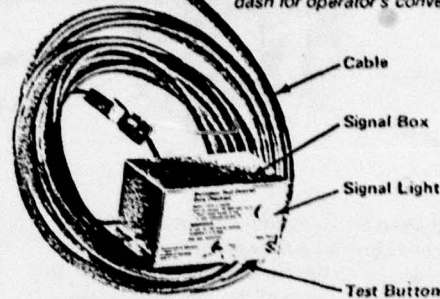

Complete Kits

Complete Donaldson Dust Detector Kits

DDX00-4251	Single System 24 Volt D.C.
DDX00-4252	Dual System 24 Volt D.C.
DDX00-4254	Quad System 24 Volt D.C.
DDX00-4200	Single System 12 Volt D.C.
DDX00-4202	Dual System 12 Volt D.C.

Service Parts

Service Part	Part Number
Signal Box, Single System 24 Volt D.C.	P12-6082
Signal Box, Dual System 24 Volt D.C.	P12-6084
Signal Box, Quad System 24 Volt D.C.	P12-6085
Signal Box Single System 12 Volt D.C.	P12-6083
Signal Box Dual System 12 Volt D.C.	P12-6296
Dust Sensor (Replace with each Air Cleaner Element change)	P12-6088
Cable Assembly, 15 feet, Type SJT	P12-6086
Switch-Sensor Housing Assembly	P12-6089
Switch-Sensor Housing Gasket	P12-6090
Venturi Assembly	P12-8449
Venturi Gasket	P12-6091
Fuse	SFE 9 (Available locally)

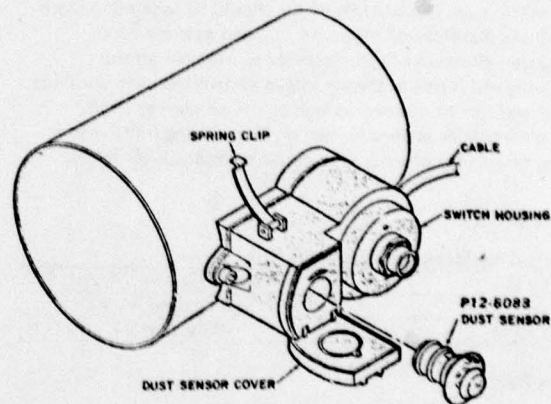

Service

The only service part which must be replaced at each filter element change is the P12-6088 Dust Sensor. It is easily exchanged by opening the spring clip holding the dust sensor cover in place. Refer to Bulletin P45-7649 Service Instructions.

Donaldson Company, Inc. reserves the right to change or discontinue any model or specification at any time and without notice.

Donaldson products are available from:

donaldson



Donaldson Company, Inc.
1400 West 94th Street
Minneapolis, Minnesota

Mailing Address
Box 1299
Minneapolis, Minnesota 55440



installation instructions

Donaldson Dust Detector

Fig. 1

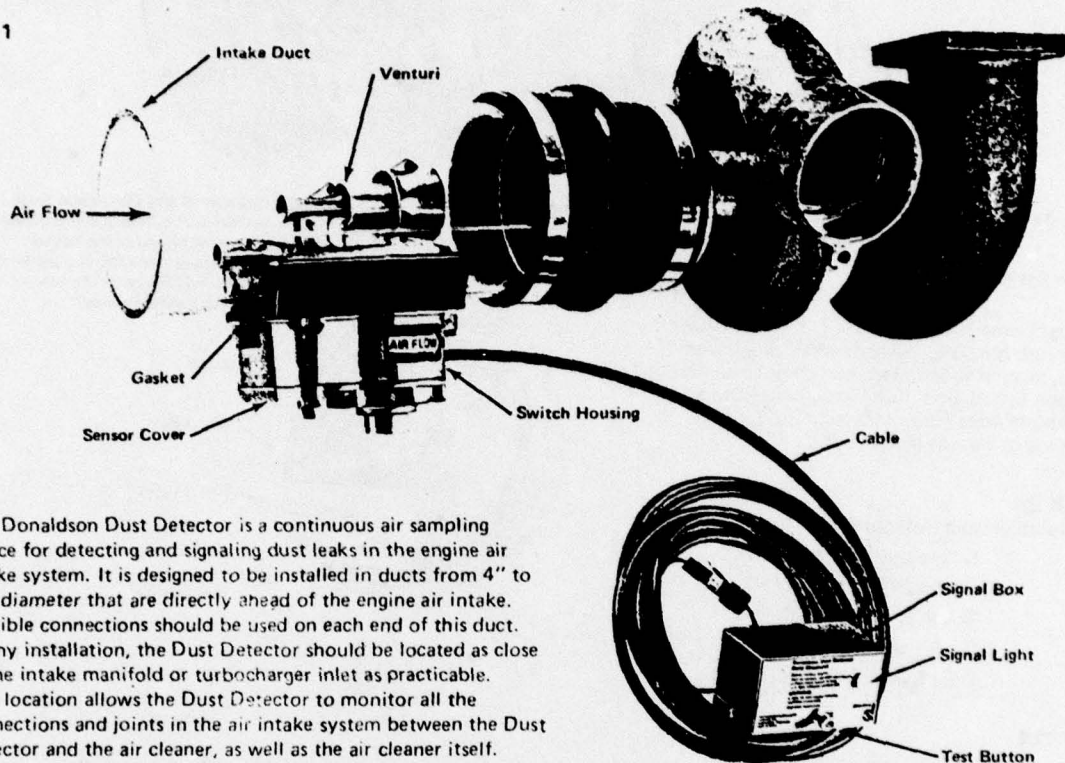

The Donaldson Dust Detector is a continuous air sampling device for detecting and signaling dust leaks in the engine air intake system. It is designed to be installed in ducts from 4" to 10" diameter that are directly ahead of the engine air intake. Flexible connections should be used on each end of this duct. In any installation, the Dust Detector should be located as close to the intake manifold or turbocharger inlet as practicable. This location allows the Dust Detector to monitor all the connections and joints in the air intake system between the Dust Detector and the air cleaner, as well as the air cleaner itself. Models are available with one, two or four sensing units with a single signal box for engines with single or multiple air inlets.

Complete Kits

Complete Donaldson Dust Detector Kits

DDX00-4251	Single System 24 Volt D.C.
DDX00-4252	Dual System 24 Volt D.C.
DDX00-4254	Quad System 24 Volt D.C.

Service Parts

Service Part	Part Number
Signal Box, Single System, 24 Volt D.C.	P12-6082
Signal Box, Dual System, 24 Volt D.C.	P12-6084
Signal Box, Quad System, 24 Volt D.C.	P12-6085
Dust Sensor (Replace with each Air Cleaner Element change)	P12-6088
Cable Assembly, 15 feet, Type SJT	P12-6086
Switch-Sensor Housing Assembly	P12-6089
Switch-Sensor Housing Gasket	P12-6090
Venturi Assembly	P12-8449
Venturi Gasket	P12-6091
Fuse	SFE 9 (Available locally)

Decal pictured is affixed to each signal box. It is important that operators are familiar with the Daily Checkout and Warning Instructions indicated on this decal.

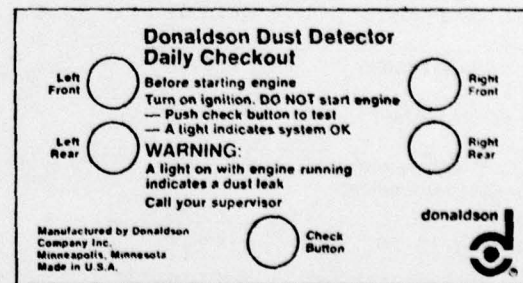

For proper installation, proceed as follows:

1

The best location for the Donaldson Dust Detector venturi and switch is in the bottom of a straight duct just ahead of the intake manifold or turbocharger inlet. A straight section, at least 7.25" long, is required for installation. The minimum duct inside diameter is 3.88". See Figure 1.

Bulletin No. P45-7649

Rev. - 2/76

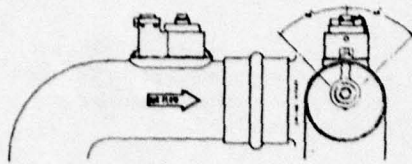

Fig. 2

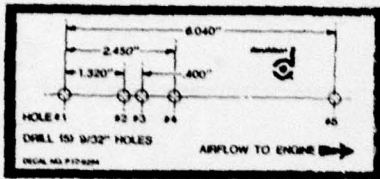

Fig. 3

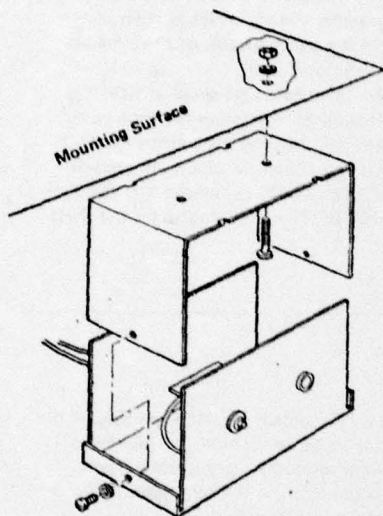

Fig. 4

2

If it is necessary to place the venturi and switch housing immediately downstream of a bend in the intake duct, the unit should be mounted on the outside of the bend. See Figure 2.

3

Five mounting holes are required in the duct wall as shown on template provided. See Figure 3. Place template in actual mounting location of the Dust Detector. Carefully center-punch and drill hole size according to template. Remove template. Clean the inside of the duct carefully to protect the engine from damage.

4

Place pressure-sensitive gasket, P12-6091, on venturi after removing paper backing. The venturi is placed inside the duct over the five closely spaced holes, large end toward engine intake. Use a 1/4-28 x .75 in. bolt in hole No. 4. Engage the internal nut in the venturi assembly and tighten bolt securely using a 3/16" allen wrench, keeping the pump in line with the other holes. The internal nut is a deformed thread locknut and the bolt will turn somewhat hard. Maintaining alignment can be done by using a 1/4-28 x 1.5 in. bolt in hole No. 1 temporarily. **NOTE:** Be sure to remove bolt from hole No. 1.

5

Check air passages in protruding bosses of the switch housing. The air passages should be clear of obstruction. Align gasket on switch-sensor housing. Place the switch housing over the end holes, Nos. 1 and 5, large end toward engine intake. The bosses will fit through the two closely spaced holes and into the pump assembly. Place the 1/4-28 x 1.5 in. socket head bolt in hole No. 1 and engage the captivated nut in the pump assembly. Place the second 1/4-28 x 1.5 in. socket head bolt in hole No. 5 and engage the second captivated nut. Pull both tight. Make certain the P12-6088 Rubber Dust Sensor is installed and the service cover latched.

6

The 1/4-28 x 1.5 in. and .75 in. long bolts supplied with the kits are for use with ducts up to .10 inches thick. Use 1/4-28 x 1.75 in. and 1.0 in. bolts (not supplied) for ducts from .10 in. to .35 in. thick.

7

Connect cable to switch housing receptacle. Route and secure cable along frame members etc. into cab. **CAUTION:** Avoid exhaust pipes and other heat sources.

8

Mount signal box in an available location in the cab, visible to operator (Figure 4). The signal box cover should be removed from the signal box prior to mounting. Heads of mounting bolts must be inside the box to avoid interference with internal components. Reassemble signal box. The paired leads from the signal box come with butt end connectors assembled to them. Place the cable wires in pairs in the connectors and crimp tightly. Connect wires—black to black and white to white. The signal box housing must be grounded either by mounting bolts or by adding an additional grounding wire. **NOTE:** When installing dual or quad systems, connect paired leads as indicated on the marking.

9

Connect the power lead with the fuse as close as possible to any terminal on the vehicle electrical system that is energized when the engine is running, and dead when the engine is stopped—such as the accessory side of the accessory switch. Proceed to Installation Checkout.

Installation Checkout

Before your Donaldson Dust Detector is put into service, please check these points:

1. Turn on accessory circuit that powers the Dust Detector system.
2. Push test button on front of signal box. The signal light(s) should come on and remain on until the test button is released. If so, your system is operational.
3. No light—If the light does not come on, proceed to No. 3 of the Trouble Shooting Guide. After correcting the problem, repeat No. 2.
4. If light is on without pushing the test button, proceed to No. 2 of the Trouble Shooting Guide. After correcting the problem, repeat No. 2.

Trouble Shooting Guide

Symptom	Cause	Remedy
1 Light comes on with engine at high idle or full load and goes off with engine stopped and circuit energized.	Gross Dust Leak	Visually check the intake system for damage, bent air cleaner, broken or damaged pipes, split or loose hose connections, etc. If the reason for dust entry is not determined by these checks, it will be necessary to disassemble the air intake system and visually check for leaks from the clean air side of the element back to the turbocharger or engine inlet. Because most leaks found by this device are small in size, it is imperative to check the inlet components with extreme care. Most of the time dust streaks will indicate the point of entry. After the cause of the leak is found and corrected, the entire intake system must be carefully cleaned to remove any residual dust that could cause an additional leak indication by the Dust Detector. Install a new dust sensor.
2 Light comes on with system energized but engine not running. Note: The Donaldson Dust Detector utilizes a normally closed circuit as a fail-safe feature. Any break in the circuit will cause the light to come on when the system is energized.	<ol style="list-style-type: none"> a. Dust sensor not in socket b. Cover not closed and latched c. Disconnected cable, broken cable or connectors, defective switch housing, defective light box. 	<ol style="list-style-type: none"> a. Push sensor in firmly b. Close and latch cover c. Check to see that cable is connected at switch housing. If the light is on and the cable appears to be correctly installed—to determine the problem area, disconnect cable at the switch housing. Insert a U shaped connector in the two holes in the plug end of the cable as shown in Figure 5. With the cable shorted in this manner, a light out indicates a defective switch housing. Replace switch housing. If the light remains on with the cable shorted, the problem is a defective cable or light box. Cut the cable at the light box side of the butt connectors. Short the leads together. If the light goes out, the cable is defective. Replace the defective cable. If the light remains on, the light box is defective. Replace light box.
3 Light does not come on when test button is pushed.	<ol style="list-style-type: none"> a. No power to Dust Detector b. Bad connection in box c. Defective light or resistor 	<ol style="list-style-type: none"> a. Check and correct power at fused lead connection, fuse in fuseholder or broken power lead wire. Signal Box not grounded b. Check and repair wiring in signal box c. Replace signal box
4 Light on at idle, but goes out at high idle or full load.	<ol style="list-style-type: none"> a. Faulty switch housing 	<ol style="list-style-type: none"> a. Replace switch housing

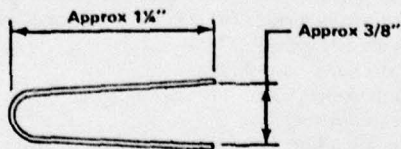
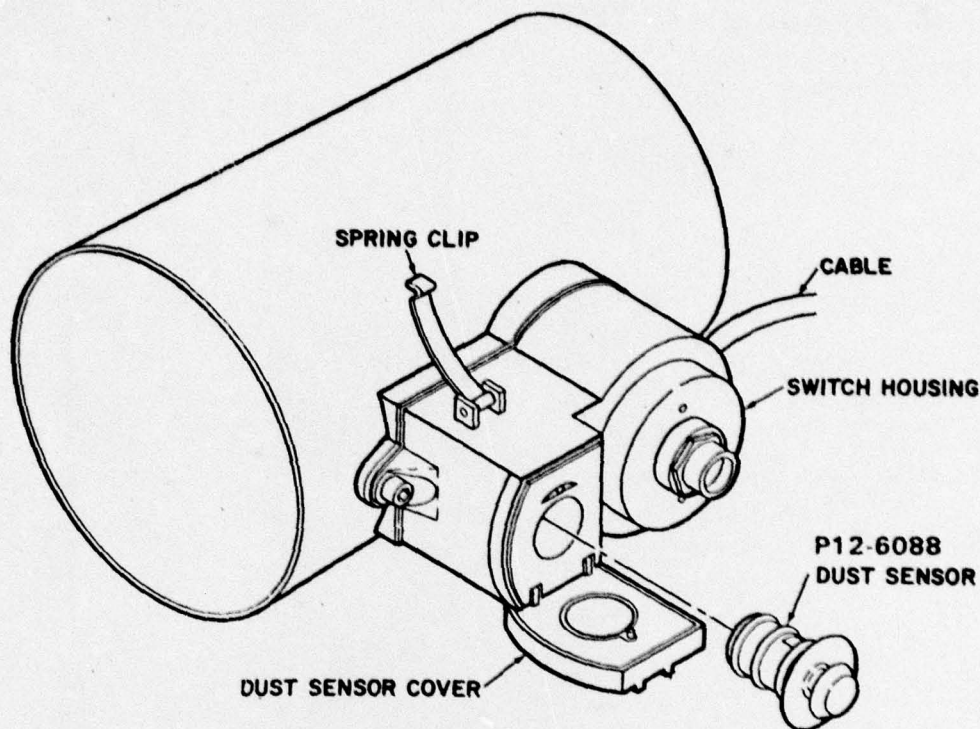

Fig. 5 18 or 16 gauge solid wire

Donaldson Dust Detector Service Instructions



The Donaldson Dust Detector is energized at all times during engine operation. **IT IS MANDATORY THAT THE DUST SENSOR PART NO. P12-6088 BE REPLACED AT EACH ELEMENT CHANGE.**

To replace the P12-6088 Dust Sensor:

1. Shut engine off.
2. Remove accumulated dust on and around the outside of the dust sensor cover before opening.
3. Withdraw the dust sensor by pulling and twisting slightly being careful not to spill any dirt into the receptacle.
4. Install a new sensor by pushing firmly until it reaches the bottom of the receptacle. Close and latch cover. **NOTE:** The sensor will not allow the cover to close completely unless it is properly seated.
5. Be sure to check your system:
 - a. Turn on accessory circuit that powers the Dust Detector system.
 - b. Push test button on front of signal box. The signal light should come on and remain on until the test button is released. If so, your system is operational.
6. If light remains on refer to trouble shooting guide.

Complete Kits

Complete Donaldson Dust Detector Kits

DDX00-4251	Single System 24 Volt D.C.
DDX00-4252	Dual System 24 Volt D.C.
DDX00-4254	Quad System 24 Volt D.C.

Service Parts

Service Part	Part Number
Signal Box, Single System, 24 Volt D.C.	P12-6082
Signal Box, Dual System, 24 Volt D.C.	P12-6084
Signal Box, Quad System, 24 Volt D.C.	P12-6085
Dust Sensor (Replace with each Air Cleaner Element change)	P12-6088
Cable Assembly, 15 feet, Type SJT	P12-6086
Switch-Sensor Housing Assembly	P12-6089
Switch-Sensor Housing Gasket	P12-6090
Venturi Assembly	P12-8449
Venturi Gasket	P12-6031
Fuse	SFE 9 (Available locally)

Donaldson Company, Inc. reserves the right to change or discontinue any model or specification at any time and without notice.

Equal Opportunity Employer

Copyright 1973 Printed in U.S.A. SM276KP

B-7

donaldson



Donaldson Company, Inc.
1400 West 94th Street
Minneapolis, Minnesota

Mailing Address:
Box 1299
Minneapolis, Minnesota 55440

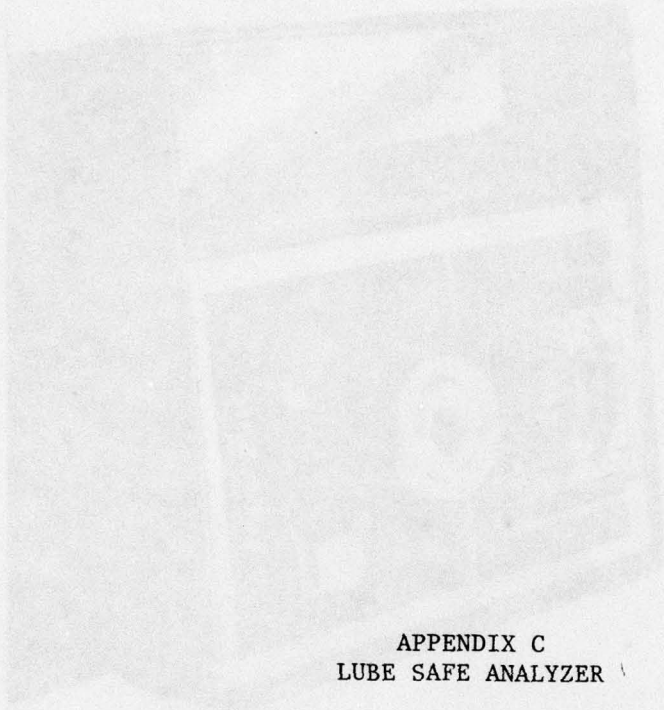

APPENDIX C
LUBE SAFE ANALYZER

Operating Manual

LubeSafe
OIL QUALITY ANALYZER

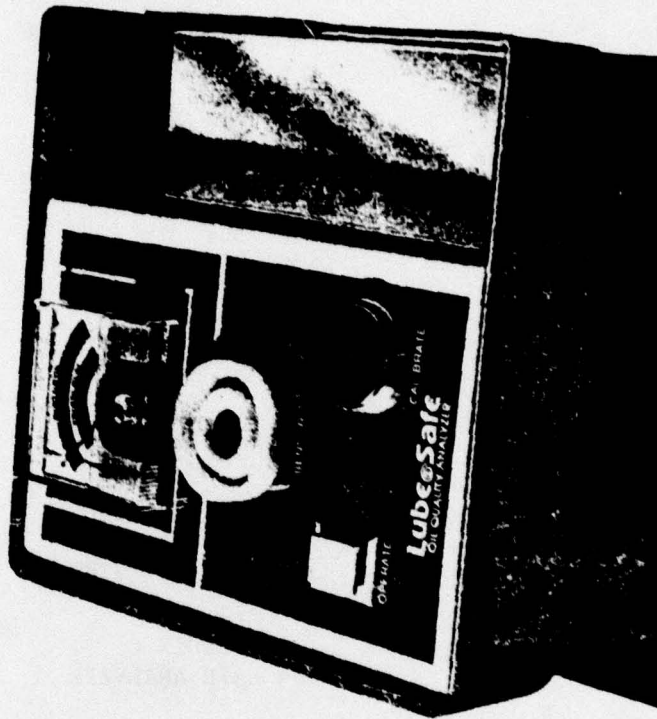

LIMITED WARRANTY

NORTHERN INSTRUMENTS CORPORATION, hereafter referred to as NORTHERN, warrants that LUBE-SAFE will be free from defects in parts and workmanship for a period of one year from date of purchase--when used as instructed in the manual furnished with the instrument. This warranty does not extend to instruments which have been subjected to misuse, neglect or accident. Any attempt to open the sealed unit or make any adjustments not covered in the manual will void the warranty.

THIS WARRANTY IS IN LIEU OF ALL OTHER WARRANTIES, EXPRESSED OR IMPLIED, INCLUDING WARRANTIES OF MERCHANTABILITY AND FITNESS FOR PURPOSE, ANTICIPATED PROFITS, LOSS OF TIME, CONSEQUENTIAL DAMAGES OR OTHER LOSSES INCURRED BY THE USER IN CONNECTION WITH THE USE OF THIS INSTRUMENT.

NORTHERN's liability under this warranty shall be limited to the repair or replacement of any part or parts thereof which proves, upon NORTHERN's examination, to be defective within the one year warranty period from date of purchase.

After the one year warranty period, any repairs to the instrument will be charged to the user on the basis of the cost of components and labor required.

NORTHERN reserves the right to make changes in the design or construction of this instrument at anytime, without incurring any obligation to make any change whatever to units previously sold or delivered.

All service will be performed at the factory. Instruments requiring service must be carefully packed and shipped prepaid to the address noted below.

**N.I.C. NORTHERN
INSTRUMENTS CORP.**

6680 N. HIGHWAY 49, LINDO LAKES, MINNESOTA 55014
PHONE 612/794-1250
TELEX 290-431

FOREWORD

Oil is subjected to high temperature and extreme pressures during engine operation. An atmosphere conducive to oxidation is usually present in the crankcase. A variety of contaminants enter the oil system. While some contaminants are inert, others are chemically active or cause undesirable chemical reactions. The physical and electro-chemical properties of the oil change during use and it is this change that is important and affects the lubricating capability of the oil. For this reason an analysis of the new (unused) and used oil should be conducted frequently to determine their relative conditions. This is ascertained by evaluating the changes in physical and electro-chemical properties. The interpretation of these changes, as they affect engine performance, is of fundamental significance. **ONE IMPORTANT AND FUNDAMENTAL ELECTRO-CHEMICAL PROPERTY OF OIL IS ITS DIELECTRIC CONSTANT.**

LUBE-SAFE detects, measures and reports the **TOTAL EFFECT** of contamination on the dielectric constant of oil. By doing so, LUBE-SAFE makes it possible to determine when oil is still usable, thus permitting longer intervals between changes. Even more importantly, overhauls can be postponed by detection of impending lubrication or mechanical failure.

Further, the sensor and operating range of LUBE-SAFE has been designed to deal specifically with the current swing to longer oil drain intervals, which have resulted from engine and filter refinements and increased use of synthesized oils.

Northern Instruments Corporation is a manufacturer of unique proprietary products developed from our technological base, which is thin film chemistry. The term "thin film" as used here, refers to research into the behavior and functioning of molecules in very thin layers. The sensor in LUBE-SAFE owes its accuracy and sensitivity to this research.

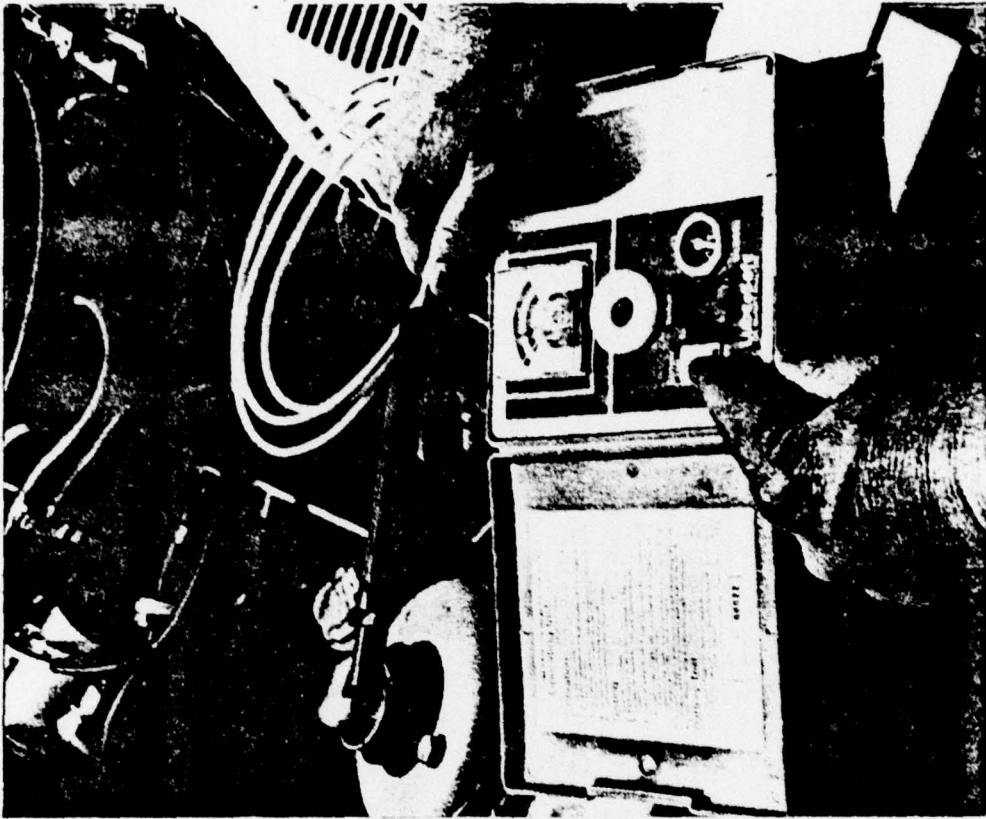

THIS PAGE IS BEST QUALITY PRACTICE
FROM OIL ANALYSIS TO DDD

GENERAL INFORMATION

1. There are hundreds of oils on the market processed for specific lubrication purposes. The dielectric constant of these oils can vary between brands and types. This need not have anything to do with the quality of a particular oil processed for a specific purpose — it simply means that different types of oil additives, or their lack, will result in dielectric constant variations in oil.

For this reason leading users of oil recommend that the interpretation of an analysis is, in part, a comparison between the properties of the unused oil and the properties of the used oil. To accommodate this, LUBE-SAFE has been designed to be calibrated quickly and easily to a zero reference with the same brand and type of oil in an unused state as the used oil to be tested.

2. As the sensor is sensitive to moisture, do not operate LUBE-SAFE in rain, snow or fog.
3. If LUBE-SAFE is subjected to significant temperature changes (for example, from 45° F. to 75° F.) then recalibrate the instrument as close as possible to the extremes of the range.
4. Always clean the sensor cavity thoroughly.
5. When testing make it a practice to fill the oil sensor cavity to the top every time.
6. While it is possible to obtain an oil sample from the engine's dipstick, it is strongly recommended that our SAMPULLER (order card enclosed) be used for sampling purposes. Dipstick samples can be contaminated with moisture or other mis-leading contaminants. SAMPULLER allows the user to obtain excellently representative samples at any crankcase level.
7. LUBE-SAFE is as ruggedly constructed as it can be and remain the sensitive instrument it is; however, please treat it with reasonable care.

OPERATING FEATURES

1. Oil Status Indicator
Visually indicates the status of oil test sample, as compared to the calibration oil sample.
2. Meter Adjustment
Screwdriver adjustment which will zero Indicator pointer with instrument "OFF".
3. Tippetto Switch
 - a. Operates instrument when tipped toward the operator, the Operate position, and held down.
 - b. Indicates status of Battery when tipped away from operator, the Battery Test position, and held down.
4. Calibrate Screw
Screwdriver adjustment which will zero Indicator pointer with calibration oil sample in Oil Sensor cavity. Snap on cap removed for access.
5. Oil Sensor
Oil to be calibrated or tested is placed in Oil Sensor cavity.
6. Battery Well
Holds 5.6V Mercury Battery. Screw top off to gain access to well.

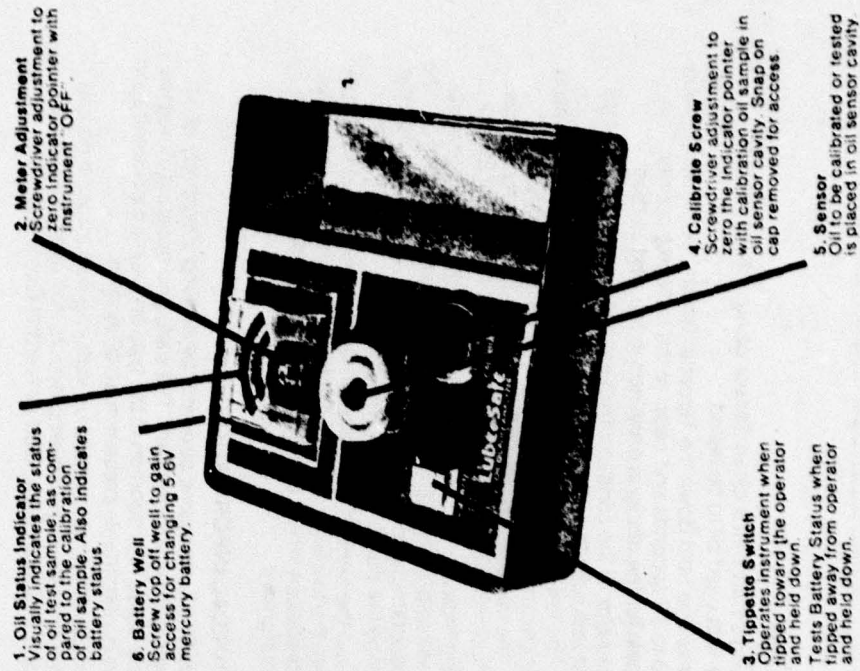

OPERATING INSTRUCTIONS

Careful and continued adherence to the few simple directions below will provide the operator with the technique necessary to insure dependable operation.

The instructions are broken down into two categories: CALIBRATION, setting the unit to a zero reference with the same brand and type of oil in an unused state as the used oil to be tested; and TESTING, measuring and reporting the change in the unused oil's dielectric constant.

CALIBRATION

1. Tip and hold down Tippette Switch in Battery Test position. The pointer must come to rest in the Battery OK zone. If not, replace battery.
2. Wipe Sensor cavity carefully and thoroughly with clean, dry tissue or cotton wad.
3. Fill the Sensor cavity with new oil of same make and grade as oil to be tested.
4. Tip and hold down Tippette Switch in Operate Position. Zero the pointer of the Oil Status Indicator by turning the Calibrate Screw in either a clockwise or counterclockwise direction. Release the Tippette Switch.
5. Again thoroughly clean the Sensor cavity. The instrument is now calibrated and ready for testing used oil. Recalibration should not be necessary unless the unit is subjected to significant humidity or temperature changes, although it is a good practice to recheck calibration occasionally during testing.

TESTING

1. Always start with a clean Sensor cavity. Fill the Sensor cavity with used oil to be tested.
2. Press and hold down the Tippette Switch in Operate Position for 10 to 15 seconds and observe the indicator pointer. The rationale for the pause is explained in the next section.
3. The color of the zone in which the indicator pointer comes to rest indicates the oil's condition.
 - a. The lower scale, (petroleum) is used for petroleum based oils (recommended oil changes of up to 7,500 miles).
 - b. The upper scale, (synthetic) is used for synthesized oils (recommended oil changes at 15,000 miles and higher).
4. If the Indicator pointer comes to rest in the green zone, the oil is still satisfactory. If the pointer comes to rest in a red zone the oil is contaminated enough to be changed. The further into the red zone the pointer moves, the greater the contamination.
5. Clean the Sensor cavity and proceed to the next test sample. See the following section, Technical Information, for useful interpretations which can be made through experience with the instrument.

TECHNICAL INFORMATION

LUBE-SAFE measures oil quality by sensing a property of oil called the dielectric constant. The dielectric constant increases or decreases in proportion to the type and relative concentration of the contaminants present in an oil system.

1. Oxidation and acids build up with engine running time and are the primary degradation products in engine lubricating oils and thus are considered as Normal Contaminants.

TECHNICAL INFORMATION

2. Sludge, Dirt, Fuel Soot, Water, Anti-Freeze, Metal Particles and Gasoline are other contaminants encountered which are or are not present depending on the health of the lubricating system.

3. Fortunately the more potentially catastrophic of these contaminants, i.e., Water, Anti-Freeze, Metal Particles and Gasoline are readily distinguishable.

- a. Water and Anti-Freeze traces cause the Indicator pointer to drift persistently to the right or to "peg" immediately.
- b. The presence of Metal Particles will cause a similar reaction although the pointer movement will generally be more erratic and jerky as it moves to the right as the particles settle to the bottom of the Sensor cavity.

It is in order to observe these types of reactions that we request the Operate Switch to be held down for 10 to 15 seconds.

4. The effect of Gasoline contamination is unique in that it is the only one that causes a decrease in the dielectric constant. All the other contaminants have a positive effect. We already know that an oil's dielectric constant changes in proportion to the type and concentration of contaminants present in the oil.

As a result:

- a. The unit's Indicator pointer will come to rest in the rejection zone to the left of "0" when gasoline is present in sufficient quantity to overcome the contaminants in the oil that cause an increase in the dielectric constant.
- b. The optimum time to detect Gasoline would be when the oil was as slightly used as possible.
- c. The Gasoline contamination could "cancel out" the normal expected gradual increase in the dielectric constant

as the dilution increases. In other words the unit gives the same or lower reading test, after test, after test, instead of gradually increasing.

5. LUBE-SAFE's red, or oil rejection zones reflect our experience with correlated laboratory tests for a "safe rejection threshold" for standard petroleum-based multi-viscosity and univiscosity oils and the new long drain synthesized oils. We stress that this is a suggested threshold. Some users based on their own operating criteria and laboratory analysis may decide to change oil further into the Rejection Zone. They certainly have this option.
6. Following an oil change, especially with detergent oils, a test may show the pointer slightly in the left hand rejection zone for the first 500 miles, thereafter tests will show pointer movement to the right. This is attributable to the action of the additives in the new oil.

MAINTENANCE

LUBE-SAFE requires very little maintenance. Thorough cleaning of the sensor after testing is, of course, a must. If oil is spilled on the instrument's face, it should be wiped off promptly. Should the instrument be dropped or bumped hard, it is advisable to recheck the calibration.

The power source for LUBE-SAFE is a 5.6V mercury battery which is available from our Customer Service Department.

To change the battery simply use a coin to remove the cap from the battery well and replace the old battery with the new battery, making sure that the positive (+) end of the battery enters the well first.

WARRANTY AND SERVICE

LUBE-SAFE is warranted against defects in materials and workmanship for a period of one year from date of purchase. All service on LUBE-SAFE will be performed at the factory

THIS PAGE IS BEST QUALITY PRACTICABLE
FROM COPY FURNISHED TO DDC

DISTRIBUTION LIST

1. Project Manager, M60 Tanks
Attn: DRCPM-M60-E
Warren, MI 48090
2. Product Manager, M113
Warren, MI 48090
3. HQ, DA (DALO-SML)
Washington, DC 20314
4. Commander
FORSCOM
Ft. McPherson, GA 30330
(AFLG-REG)
5. Commander
MERADCOM
Ft. Belvoir, VA 22060
(DRDME-GL)
6. Commander
DARCOM
Alexandria, VA 22333
(DRCMM-MS)
7. Commander
MRSA
Lexington, KY 40511
(DRXMD-MS)
8. Col Grear, DIO
Ft. Hood, TX 76546
9. Commander, TARADCOM
Attn: DRDTA-RGE
Warren, MI 48090