

AD-A077 499

CHEMICAL AND RADIOLOGICAL LABS ARMY CHEMICAL CENTER MD
EVALUATION OF AIR MONITORING INSTRUMENTS, (U)
NOV 52 L M HARDIN , D LITTLETON

F/G 14/2

UNCLASSIFIED

AEC-WT-536

NL

1 OF 1
AD-A077499



PHOTOGRAPH THIS SHEET

AD A 077499

DTIC ACCESSION NUMBER



LEVEL



INVENTORY

REC
WT-536
DOCUMENT IDENTIFICATION

DISTRIBUTION STATEMENT A
Approved for public release;
Distribution Unlimited

DISTRIBUTION STATEMENT

ACCESSION FOR	
NTIS	GRA&I <input checked="" type="checkbox"/>
DTIC	TAB <input type="checkbox"/>
UNANNOUNCED	<input type="checkbox"/>
JUSTIFICATION	
Per Hq. on file	
BY	
DISTRIBUTION /	
AVAILABILITY CODES	
DIST	AVAIL AND/OR SPECIAL
A	

DISTRIBUTION STAMP

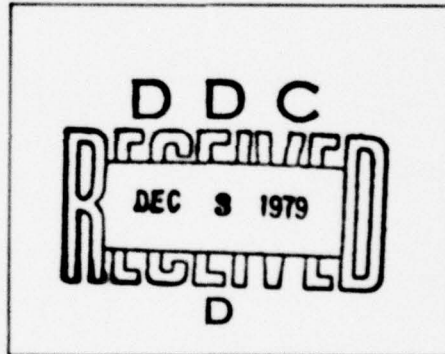

DATE ACCESSIONED

79 11 21 132

DATE RECEIVED IN DTIC

PHOTOGRAPH THIS SHEET AND RETURN TO DTIC-DDA-2

AD A 072499

UNCLASSIFIED

[REDACTED]

This document consists of 61 pages
No. 227 of 366 copies, Series A

OPERATION SNAPPER

Project 6.7

**EVALUATION OF AIR MONITORING
INSTRUMENTS**

REPORT TO THE TEST DIRECTOR

by

Luther M. Hardin
D'Arcy Littleton, Jr.

November 1952

Chemical and Radiological Laboratories
Army Chemical Center
Maryland

[REDACTED]

UNCLASSIFIED

OPERATION ENRICHED
PROJECT
EVALUATION OF AIR MONITORING
INSTRUMENTS

Reproduced Direct from Manuscript Copy by
AEC Technical Information Service
Oak Ridge, Tennessee

Inquiries relative to this report may be made to

Chief, Air Forces Special Weapon Project
P. O. Box 2610
Washington, D. C.

~~CONFIDENTIAL~~

UNCLASSIFIED

ABSTRACT

The Chemical Corps Portable Air Sampler, E-22, and the modified Tracerlab Continuous Air Monitor were tested for adequacy and applicability to radiological air monitoring problems. Tests were made of aerosols caused by Shots 5, 6, 7, and 8 of Operation SNAPPER and aerosols due to the re-dispersion of contaminant from Operation JANGLE.

It has been shown that:

1. The Portable Air Sampler, E-22, is a basic instrument worthy of further consideration but requires additional modification and tests before standardization is practicable.

2. The modified Tracerlab Continuous Air Monitor is not suitable for field use since it is bulky, fragile, and complex and cannot be readily shielded from background radiation which is due to fall-out.

~~CONFIDENTIAL~~

UNCLASSIFIED

~~CONFIDENTIAL~~

UNCLASSIFIED

ACKNOWLEDGEMENTS

Acknowledgement is made of the work of Dr. J. J. Mahoney during the planning stage of this project and of the able assistance of R. B. Price throughout the course of the investigation.

The project was accomplished with the help of Pfc J. L. Lineweaver, USA, in the design of timing instruments and maintenance of electrical equipment; Cpl W. G. Janssen, USA, in the preparation and counting of samples; R. Lineberry in the installation and maintenance of generators and heavy equipment; and 2nd Lt P. D. Jones, USAF, in the performance of administrative duties at the site.

~~CONFIDENTIAL~~

UNCLASSIFIED

TABLE OF CONTENTS

ABSTRACT 3

ACKNOWLEDGEMENTS 5

ILLUSTRATIONS 8

TABLES 9

CHAPTER 1 INTRODUCTION 11

 1.1 Objective 11

 1.2 Historical 11

 1.2.1 Modified Portable Air Sampler, E-22 11

 1.2.2 The Tracerlab Continuous Air Monitor 11

CHAPTER 2 DESCRIPTION OF APPARATUS 13

 2.1 The Modified Portable Air Sampler, E-22 13

 2.1.1 Filter Holders and Mounting Positions 13

 2.1.2 Types of Filter Materials Used 14

 2.1.3 Timing Devices 14

 2.1.4 Recorders 16

 2.1.5 Counting Equipment 17

 2.2 The Tracerlab Continuous Air Monitor 17

CHAPTER 3 OPERATIONS 21

 3.1 The Portable Air Sampler, E-22 21

 3.1.1 Station Locations 21

 3.1.2 Arrangement of Samplers at Stations 21

 3.1.3 Types of Filters Used 21

 3.1.4 Assembly of Apparatus 21

 3.1.5 Recovery of Samples 22

 3.1.6 Mounting of Samples 22

 3.1.7 Counting of Samples 22

 3.1.8 Secondary (or Redispersed) Aerosol Sampling 24

 3.2 The Tracerlab Continuous Air Monitor 24

 3.2.1 Experimental Procedure 24

 3.2.2 Collection and Shipment of Samples 25

 3.2.3 Treatment of Samples at Army Chemical Center, Maryland 25

 3.2.4 Calibration Procedures 25

UNCLASSIFIED

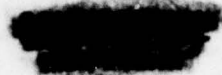

CHAPTER 4	RESULTS AND DISCUSSION	26
4.1	Portable Air Sampler, E-22	26
4.1.1	General	26
4.1.2	Shot 6	30
4.1.3	Shot 7	30
4.1.4	Secondary Aerosol Sampling	35
4.1.5	Radioautographs	42
4.2	The Tracerlab Continuous Air Monitor	42
4.2.1	Shot 6	42
4.2.2	Shot 7	43
4.2.3	Evaluation of Hazard from Secondary Aero- sol in the Operation JANGLE Area	49
4.2.4	Long Range Activity Detection	49
4.2.5	Discussion of Results	50
CHAPTER 5	CONCLUSIONS AND RECOMMENDATIONS	52
5.1	Portable Air Sampler, E-22	52
5.1.1	Conclusions	52
5.1.2	Recommendations	52
5.2	The Tracerlab Continuous Air Monitor	53
5.2.1	Conclusions	53
5.2.2	Recommendations	53
REFERENCES	54

ILLUSTRATIONS

CHAPTER 2	DESCRIPTION OF APPARATUS	
2.1	Filter Holder for Sampler	14
2.2	Portable Air Sampler with Mounting Board in Position	15
2.3	Portable Air Sampler with Tubular Extension Attached	15
2.4	Portable Air Sampler with Revolving Cover over Filters	16
2.5	Section of Typical Esterline-Angus Recorder Trace	17
2.6	Front View of the Continuous Air Monitor Show- ing the Two Count-Rate Meters and the Two-Point Strip-Chart Recorder	18
2.7	Inside View of the Continuous Air Monitor Showing the Sampling and Detection Unit with Aluminum Hood Removed	19
2.8	GM-Tube Shields	20

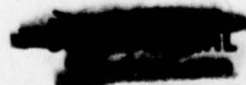

UNCLASSIFIED

~~CONFIDENTIAL~~

UNCLASSIFIED

CHAPTER 3 OPERATIONS

3.1 Mounting Guide for Filter Samples	23
3.2 Counting Shelf for Mounting Samples	23

CHAPTER 4 RESULTS AND DISCUSSION

4.1 Station Locations for Shot 6	27
4.2 Station Locations for Shot 7	27
4.3 Station Locations for Shot 8	28
4.4 Typical Decay Curve, Sample 6D15	31
4.5 Activity Collected by Instrument 6A	32
4.6 Activity Collected by Instrument 6B	32
4.7 Activity Collected by Instrument 6C	33
4.8 Activity Collected by Instrument 6D	33
4.9 Activity Collected by Instrument 6F	34
4.10 Activity Collected by Instrument 7F with Inverted Filter Holders	34
4.11 Activity Collected by Instrument 7E	35
4.12 Comparison of Activities Measured on Type 6 and MF Filters from Instruments A and B	37
4.13 Comparison of Activities Measured on Type 6 and MF Filters from Instruments C and D	38
4.14 Comparison of Activities Collected on Instruments Facing into Wind and away from Wind	38
4.15 Activity Collected by Instrument 8C with Tubular Extensions Mounted in Front of the Filter Holders	39
4.16 Activity Collected by Instrument 8D with Tubular Extensions Mounted in Front of the Filter Holders	39
4.17 Radioautographs of Selected Samples	41
4.18 Original Record, Station F-6, (Camp Mercury), Shot 6	44
4.19 Beta Concentration, Station F-6, (Camp Mercury) Shot 6	45
4.20 Gamma Concentration, Station F-6, (Camp Mercury) Shot 6	46
4.21 Beta Concentration, Station G-3, Shot 7	47
4.22 Gamma Concentration, Station G-3, Shot 7	48

TABLES

CHAPTER 4 RESULTS AND DISCUSSION

4.1 Location of Instruments at Stations for Shots 6, 7, and 8	29
--	----

~~CONFIDENTIAL~~

UNCLASSIFIED

UNCLASSIFIED

[REDACTED]

4.2	Values of b in the Expression $R = At^{-b}$	29
4.3	Flow Rates and Filter Materials Used in Operation JANGLE area Tests	36
4.4	Comparison of Flow Rate with Activity Collected	40
4.5	Station Location for Shot 6	42
4.6	Station Locations for Shot 7	43

UNCLASSIFIED

[REDACTED]

~~CONFIDENTIAL~~

UNCLASSIFIED

CHAPTER 1

INTRODUCTION

1.1 OBJECTIVE

The purpose of this project was to evaluate a modified Chemical Corps Portable Air Sampler, E-22, and a modified Tracerlab Continuous Air Monitor as to adequacy and applicability to air monitoring problems.

1.2 HISTORICAL

1.2.1 Modified Portable Air Sampler, E-22

This portable air sampler was originally developed by Test Division, Chemical and Radiological Laboratories, Army Chemical Center, as a sampler for non-radioactive material in the air including liquid and gaseous dispersions. For this purpose air was drawn through self-contained bubblers which served to remove the materials of interest. In an attempt to convert this instrument into a radiological sampler, filter holders were substituted for the bubblers and the instrument was tested during Operation JANGLE. In these tests all filters were in the horizontal plane facing upward and thus exposed to fall-out during the entire sampling period. Results obtained indicated the necessity of modifying the filter holder assembly mounting.^{1,2,3/}

Operation SNAPPER provided the opportunity to determine the efficiency of sampling immediately following a detonation and also to monitor secondary or re-dispersed aerosols in the JANGLE area.

1.2.2 The Tracerlab Continuous Air Monitor

The Tracerlab Continuous Air Monitor was developed to measure the alpha and beta plus gamma radiation from radioactive aerosols in the laboratory. The first model of this continuous air monitor was tested at Operation JANGLE and the following undesirable characteristics found:

1. There were no means of detecting and measuring the amount of external gamma radiation that contributed to the recording of the beta plus gamma radiation measurement.

2. The paper drive rewind roll had a tendency to slip. This caused the contaminated filter paper to pile up in the back of the instrument and in some cases caused rethreading through the paper drive rollers.

~~CONFIDENTIAL~~

UNCLASSIFIED

UNCLASSIFIED

~~CONFIDENTIAL~~

3. The instrument was bulky and required the use of a crane or hoist for movement in the field.

4. The calibration procedure was complicated because the concentration of the contaminant deposited on the moving paper decreased as a complex function of distance from a maximum along the centerline of the contaminated strip. This was true because a small area of the paper which moved along the sampling area diameter received air-borne contaminant for a longer period of time than did a similar area which moved along any parallel chord.

Before Operation SNAPPER, the paper drive and the air sampling assemblies were altered so that a known amount of air was sampled through one spot on the paper for a known length of time. This made the instrument a discontinuous or intermittent air monitor and thereby simplified the calibration procedure. The instrument was also modified so as to determine gamma and beta plus gamma radiation.

UNCLASSIFIED

~~CONFIDENTIAL~~

~~CONFIDENTIAL~~

UNCLASSIFIED

CHAPTER 2

DESCRIPTION OF APPARATUS

2.1 THE MODIFIED PORTABLE AIR SAMPLER, E-22

The modified portable sampler was designed as an automatic time-differential sampler which would permit the collection and measurement of the concentration of radioactivity in the atmosphere.

This sampler is basically an instrument of low power consumption containing a vacuum pump and distributor designed to produce air flow of a half-liter per minute through any one of 12 self-contained filter funnels. Changing from one sample to another is accomplished by actuating a rotary-solenoid assembly with electrical impulses. These impulses can be applied by manual switching or through the action of an external timer so that air will be drawn through each of the 12 filters, in turn, for pre-determined time intervals.

The flow rate is controlled and held essentially constant through the inclusion of a critical orifice in the air line between the vacuum pump and the distributor.

Although designed for operation from a small self-contained 6-volt lead storage battery, units were operated during these tests from separate 100 ampere-hour lead storage batteries. This was deemed advisable because of the requirement that the instruments run unattended and continuously for a four-hour period without a significant decrease in flow rate.

2.1.1 Filter Holders and Mounting Positions

The basic instrument, as modified, carried 13 plastic filter holders (Fig. 2.1). One of these holders contained the control filter while the remaining 12 were used in the collection of the actual samples. The filter holders were placed in holes in a board as shown in Fig. 2.2 because the spring bronze clips on hand were not usable.

In order to determine the optimum procedures for the sampling of particulate materials of various sizes suspended in the air, four different filter holder arrangements were tested as listed below.

1. All filters were in a vertical plane and exposed to the air for the entire four-hour sampling period. (See Fig. 2.2.)
2. Filters were in a vertical plane with a 3-inch length

~~CONFIDENTIAL~~

UNCLASSIFIED

UNCLASSIFIED

~~CONFIDENTIAL~~

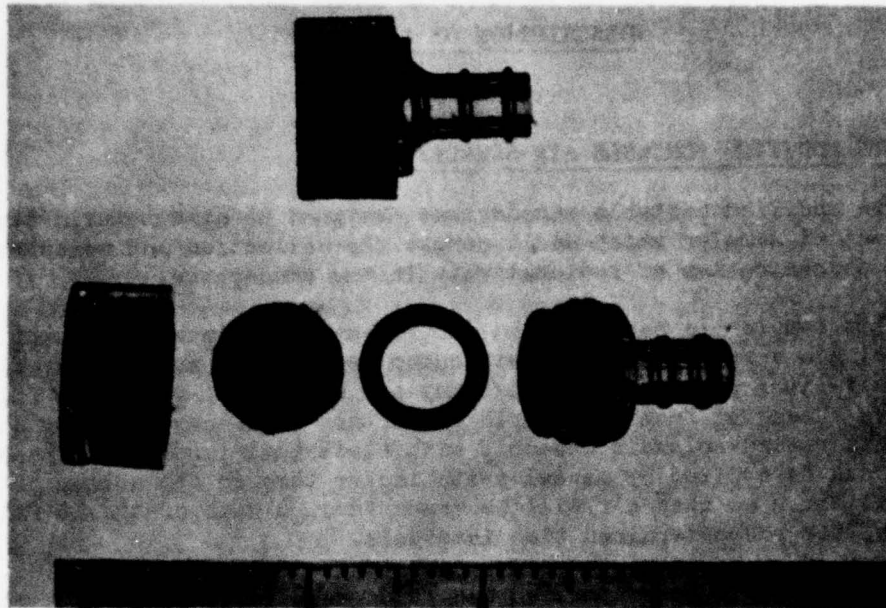

Fig. 2.1 Filter Holder for Sampler

of half-inch diameter copper tubing attached to the front of each filter holder (Fig. 2.3).

3. A circular cover attached to the distributor shaft was placed over the filters which were in a horizontal plane. This cover revolved in such a manner that a hole in the cover exposed each filter for only the period during which air was being drawn through the filter. Six additional filters through which no air was drawn were exposed for a like period of time and thus served as controls (Fig. 2.4).

4. Filters, facing downward, were placed in a horizontal plane and left uncovered for the over-all sampling period.

2.1.2 Types of Filter Material Used

The two types of filter materials used during these tests were the Chemical Corps Filter Material, Type 6, and the molecular filter material ("Millipore", Type HA, manufactured by the Lovell Chemical Company, Watertown, Massachusetts).

2.1.3 Timing Devices

Eight-day clock-relays, manufactured by Automatic Electric Manufacturing Company, were used to start the samplers at a pre-determined time and to stop them after four hours of operation.

UNCLASSIFIED

~~CONFIDENTIAL~~

~~SECRET~~

UNCLASSIFIED

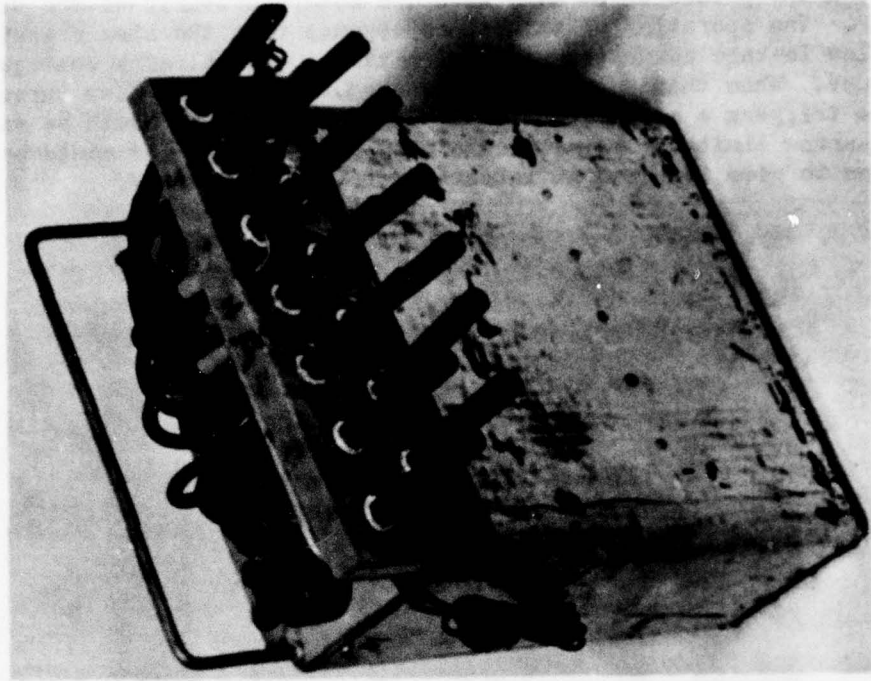

Fig. 2.3 Portable Air Sampler with Tubular Extensions Attached

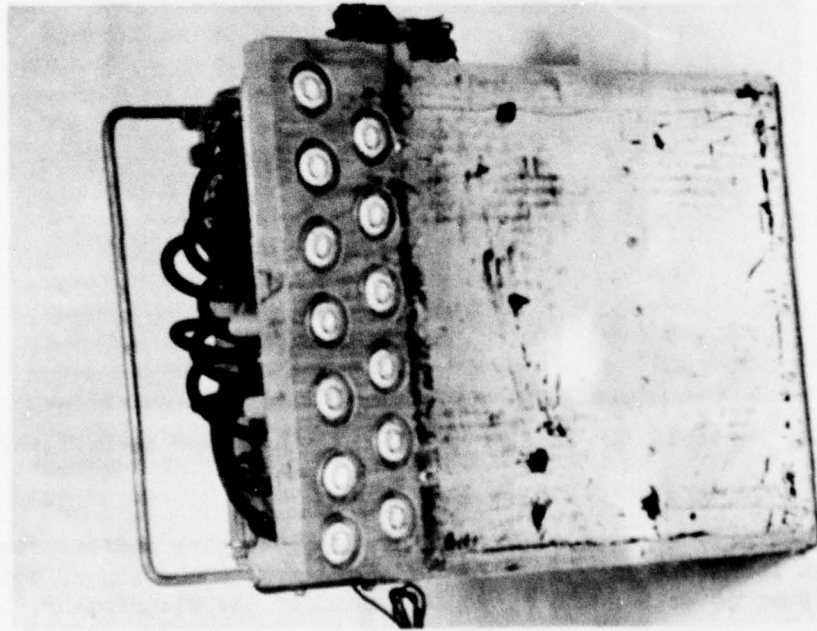
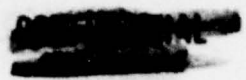

Fig. 2.2 Portable Air Sampler with Mounting Board in Position

~~SECRET~~

UNCLASSIFIED

UNCLASSIFIED



A timing device utilizing a resistance-capacitance circuit controlled the pulses which activated the rotary solenoid of the distributor. The operation of this timer depends upon the slow charging of a very low leakage condenser to the ignition potential of a voltage regulator tube. When this potential is reached, the current flow through the tube triggers a sensitive relay. The time constant could be varied within narrow limits by re-setting a rheostat. This timer could be relied upon to give impulses at intervals of 20 ± 1 minutes.

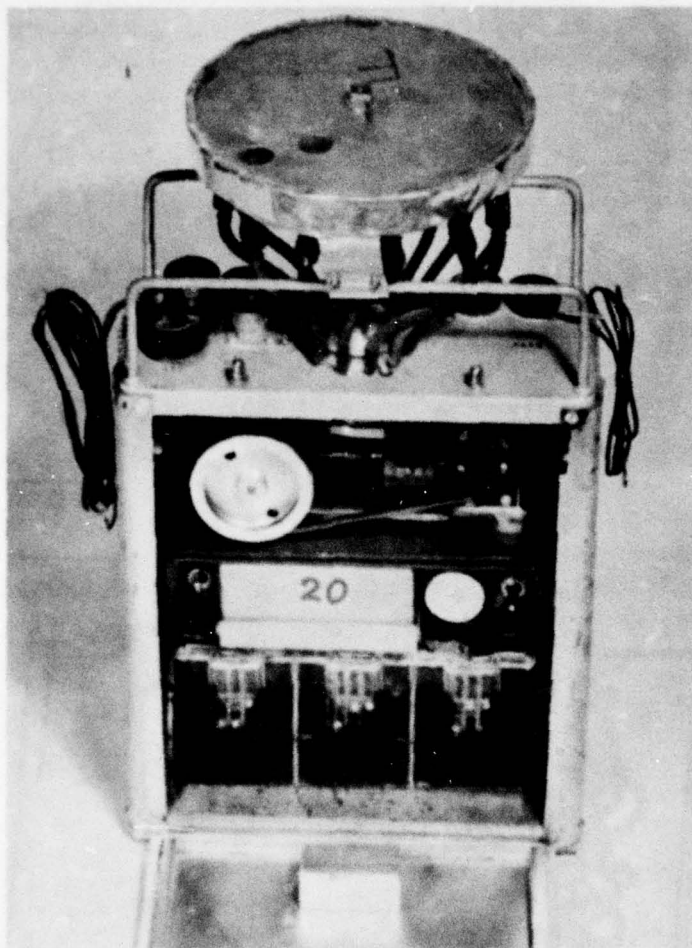
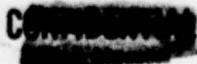

Fig. 2.4 Portable Air Sampler with Revolving Cover over Filters

2.1.4 Recorders

Esterline-Angus recorders were used to give characteristic traces which furnished an indication of the proper operation of both the vacuum pump motor and the rotary solenoid of the distributor.



UNCLASSIFIED

UNCLASSIFIED

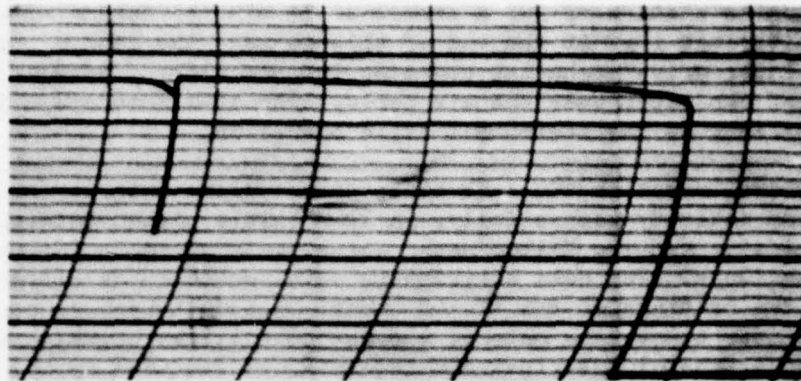

Fig. 2.5 Section of Typical Esterline Angus Recorder Trace

The recorder was so connected that a potential was applied to its terminals while the motor was running but was removed momentarily when the solenoid was actuated. During normal operation of the motor and solenoid the recorder chart shows a well-defined trace from which can be determined the individual sampling times. Figure 2.5 shows the first cycle of a typical trace. The first rise in the trace corresponds to the starting of the motor. The action of the distributor was indicated by succeeding vertical portions of the trace. The recorder thus furnished exact times for each of the sampling periods and also provided an indication of possible failure of either the motor or distributor.

2.1.5 Counting Equipment

Two complete counting rigs were used at the site for the counting of samples. Each rig consisted of a GM detector in a lead pig and a Nuclear Instrument Corporation scaler, model 162.

Intercalibration of counting rigs was accomplished by counting selected filter samples on each of the four plastic shelves in each pig.

This permitted correcting of sample readings to eliminate the effect of differences in geometry. Coincidence corrections were determined by using paired radioactive sources.

2.2 THE TRACERLAB CONTINUOUS AIR MONITOR

The Tracerlab Continuous Air Monitor consists essentially of a filter paper feed system combined with a vacuum pump (2.5 cu. ft./min.) to collect the particles from the air, and two G-M tubes mounted just above the filter paper to measure the activity of the particulate matter as it is collected. The filter paper is in the form of a strip,

UNCLASSIFIED

UNCLASSIFIED

~~CONFIDENTIAL~~

six inches wide, which passes over the two air sampling ports. The paper remains stationary for a period of 14 minutes during which air is drawn through it. At the end of this period, the vacuum pump stops and the paper drive mechanism operates for one minute, drawing a new section of the paper over the air ports. The 15-minute cycle is repeated as long as the instrument is in operation.

The two Tracerlab TGC-1 GM tubes detect gamma activity and beta-plus-gamma activity respectively. A lead shield placed between the gamma detector and the filter paper allows only gamma radiation to activate one tube. The beta activity is obtained from the difference between the readings of the two GM tubes. The GM tubes are connected to two linear count-rate meters, the output voltages of which are recorded on a two-point strip-chart recorder manufactured by the Brown Instrument Company. The entire unit was housed in a metal cabinet and together with a 4-cylinder, 15KW A.C. generator was located on a 2½-ton, 6 x 6 Army truck. In order to report the activity in terms of activity per unit volume of aerosol, it was necessary to determine absolute disintegration rates. In absolute beta counting an error of at least ± 20 per cent can be expected.^{4,5/} Unless otherwise indicated, corrections for coincidence, air path, and tube window were applied to all counting data in addition to the usual geometry corrections. See Figures 2.6, 2.7, and 2.8.

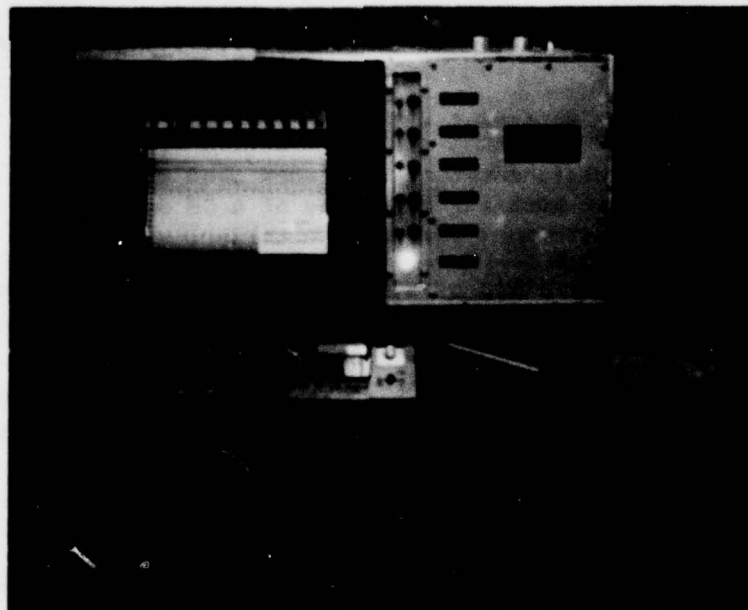

Fig. 2.6 Front View of the Continuous Air Monitor Showing the Two Count-Rate Meters and the Two-Point Strip-Chart

UNCLASSIFIED

~~CONFIDENTIAL~~

~~CONFIDENTIAL~~

UNCLASSIFIED

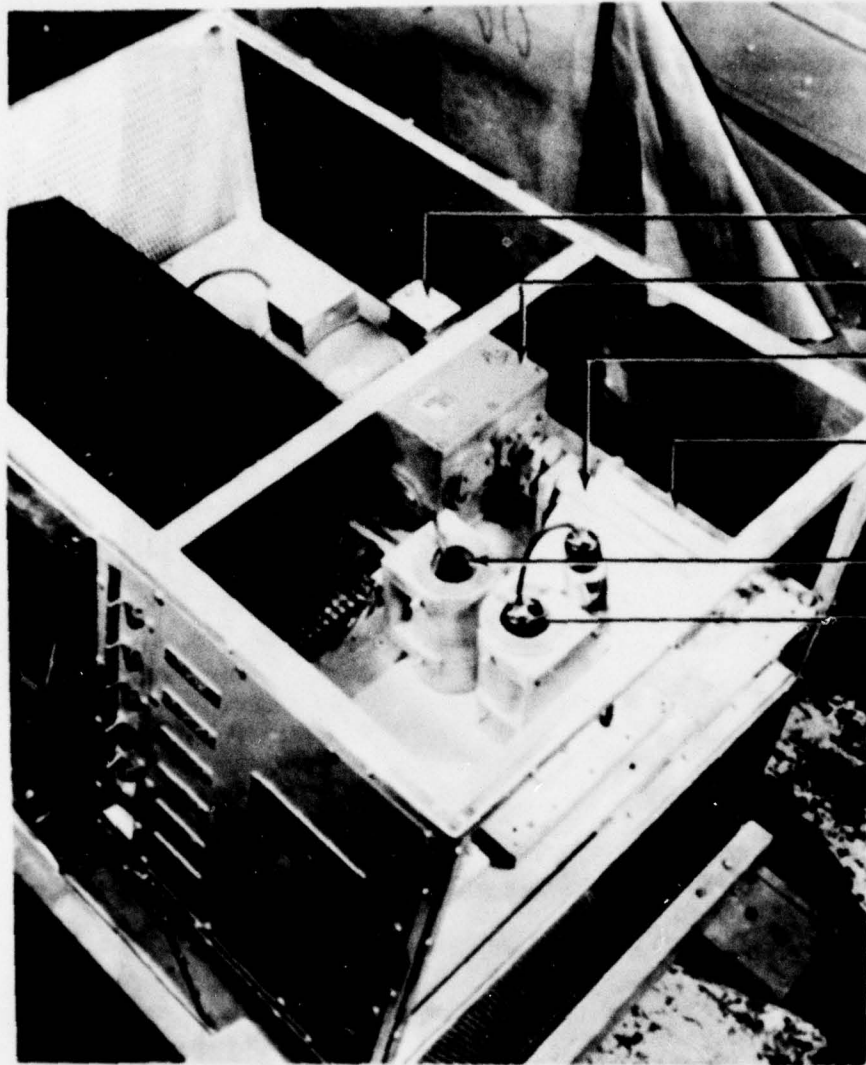

A
B
C
D
E
F

- A. Timer
- B. Paper-drive motor and gear-box
- C. Top roller of paper drive
- D. Take-up spool
- E. Beta plus gamma detector
- F. Gamma detector with pre-amplifier

Fig. 2.7 Inside View of the Continuous Air Monitor Showing the Air Sampling and Detection Unit with Aluminum Hood Removed.

~~CONFIDENTIAL~~

UNCLASSIFIED

UNCLASSIFIED

~~CONFIDENTIAL~~

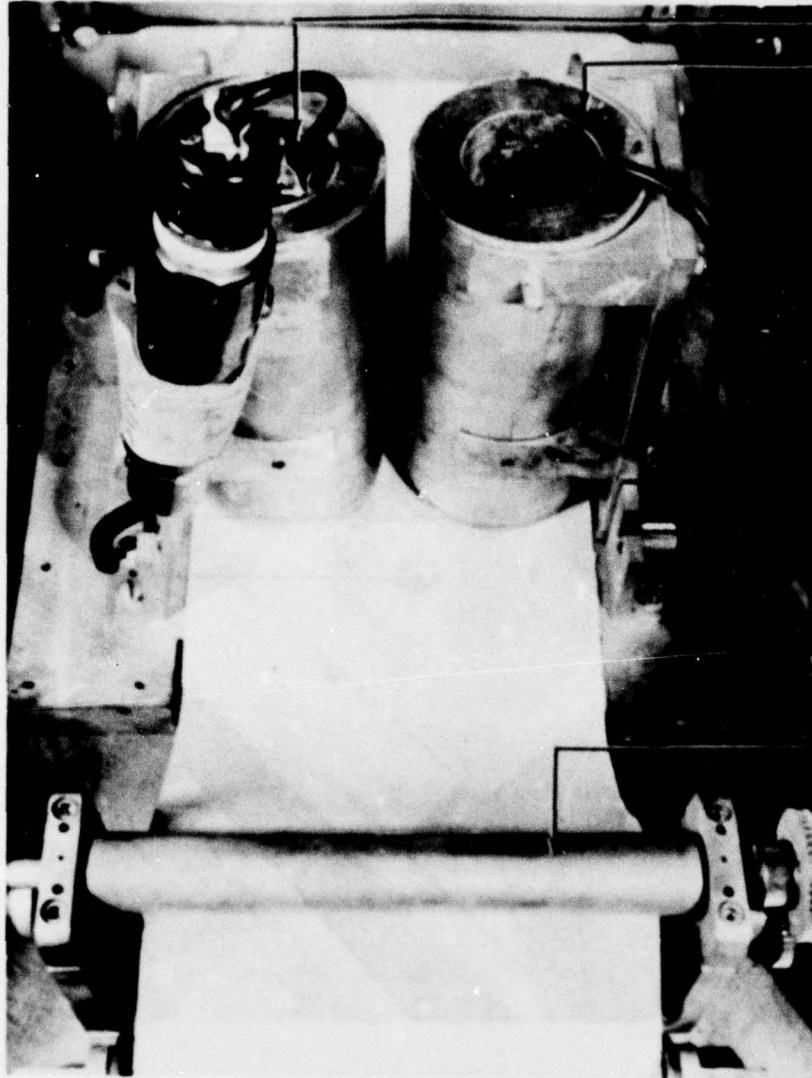

A
B

C

- A. Gamma tube shield
- B. Beta plus gamma tube shield
- C. Top roller of paper-drive

Fig. 2. GM-Tube Shields

UNCLASSIFIED

~~CONFIDENTIAL~~

~~CONFIDENTIAL~~

CHAPTER 3

OPERATIONS

UNCLASSIFIED

3.1 PORTABLE AIR SAMPLER, E-22

3.1.1 Station Locations

For each of the Operation SNAPPER shots, four stations were selected in the expected area of fall-out at distances of from 5 to 6.5 miles north to northeast of ground zero. Six modified Chemical Corps Portable Air Samplers, E-22, were set up at these four stations. By placing two samplers at each of two stations, it was possible to make comparisons between instruments having different filter holder arrangements and different flow.

3.1.2 Arrangement of Samplers at Stations

For Shots 5 and 6, samplers with filters in the vertical plane were set up along with samplers in which the filters were facing upward with a revolving cover over them as described in Section 2.1.1 (1) and (3).

For Shot 7, the samplers, which were placed in pairs at a station, had the tubular extensions in front of the filters as described in Section 2.1.1 (2). One sampler of each pair operated at the relatively high rate of approximately 2.5 liters per minute. This rate, which was obtained by removing the critical orifice, was not always constant. A sampler at another station for this test operated at the high flow rate with filters facing downward.

For the last shot, a sampler with tubular extensions in front of the filters was placed at each station. Also, at one station was placed a sampler with inverted filter funnels and at another, a sampler with rotating cover.

3.1.3 Types of Filters Used

The molecular filter was used exclusively for Shots 5 and 6 while the "Type 6" filter paper was used for Shots 7 and 8. Both types of filters were used for secondary aerosol sampling in the Operation JANGLE area.

3.1.4 Assembly of Apparatus

On D-1 day, all apparatus was assembled at the stations,

~~CONFIDENTIAL~~

UNCLASSIFIED

UNCLASSIFIED

~~CONFIDENTIAL~~

wired, and made ready for operation. Because of the necessity of starting the recorder manually, the clock-relay and the timing mechanism for the rotary solenoid were not finally set until about H-6 hours.

Samplers were set to start at times ranging from H-10 minutes to H + 10 minutes, with sampling times of approximately 20 minutes per sample. The total sampling period was 4 hours.

3.1.5 Recovery of Samples

With the exception of Shot 5, all samples were recovered at H + 6 to H + 9 hours. Samples from Shot 5 were not recovered until the following day because of a wind and dust storm which began before the sampling period had ended and continued until approximately 2200 hours on shot day.

Before the instruments were moved, all filter holder openings were covered with masking tape in order to prevent the deposition of additional radioactive material upon the filters from dust stirred up by the vehicles during transportation to the field laboratory. The instruments were then packed in well-padded boxes.

3.1.6 Mounting of Samples

The mounting of samples was begun immediately upon arrival at the laboratory at Camp Mercury. Previously numbered and coded glass microscope slides, measuring $1 \times 1\frac{1}{2}$ inches, were placed in specially designed mounting guides shown in Figure 3.1. A thin film of rubber cement was applied to the upper surface of the slide. Filter samples were very carefully removed from the filter holders with tweezers and quickly placed on the cement-covered slide. Centering of the sample on the slide was accomplished with the aid of concentric circles drawn on the mounting guide. A rubber hydrochloride film (0.45 mg/cm^2) was immediately placed over the sample and its edges firmly pressed into the cement on the edges of the slide.

3.1.7 Counting of Samples

Counting was begun, in all cases, by H + 12 hours and was continued on the two rigs until all counting had been completed. Specially constructed sample holders made possible the exact centering of the microscope slides and samples beneath the counting tube (see Fig. 3.2).

Sixteen to 20 of the radioactive samples that appeared to be the most representative were selected for decay measurements. These samples were counted every two hours the first day and then at less frequent intervals until about 300 hours had elapsed. After making corrections for coincidence and geometry for the different shelves, the

UNCLASSIFIED

~~CONFIDENTIAL~~

~~CONFIDENTIAL~~

UNCLASSIFIED

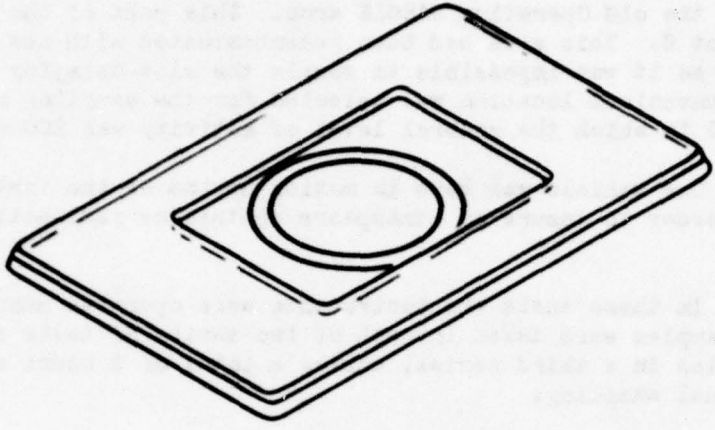

Fig. 3.1 Mounting Guide for Filter Samples

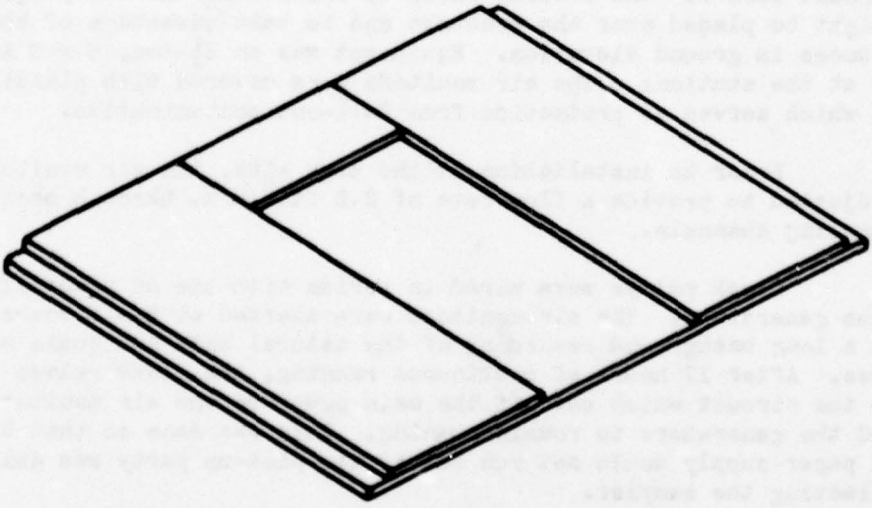

Fig. 3.2 Counting Shelf for Mounted Samples

~~CONFIDENTIAL~~

UNCLASSIFIED

UNCLASSIFIED

~~CONFIDENTIAL~~

the decay data were used to correct all counts to H + 10 hours.

3.1.8 Secondary (or Redispersed) Aerosol Sampling

In order to determine the extent to which airborne radioactive particles were present in previously contaminated areas, tests were run in the old Operation JANGLE area. This part of the project followed Shot 6. This area had been recontaminated with new material from Shot 6 so it was impossible to sample the slow-decaying material alone. A convenient location was selected for the sampling of secondary aerosol in which the general level of activity was 200 mr/hr.

One vehicle was kept in motion upwind of the instrument station in order to insure an atmosphere containing radioactive particles.

In these tests the instruments were operated manually. Four 20-minute samples were taken in each of two series of tests and two 20-minute samples in a third series, making a total of 3 hours and 20 minutes of actual sampling.

3.2 THE TRACERLAB CONTINUOUS AIR MONITOR

3.2.1 Experimental Procedure

On the basis of pre-shot meteorological data accumulated at the test site the general layout for each shot was the same (see Sections 4.2.1 and 4.2.2). Minor changes were made in station distances from ground zero for the several shots in order that the heavy equipment might be placed near the roadways and to take advantage of the differences in ground elevation. Equipment was on 2½-ton, 6 x 6 Army trucks at the stations. The air monitors were covered with plastic covers which served as protection from fall-out contamination.

Prior to installation at the test site, the air monitors were adjusted to provide a flow rate of 2.5 ft.³/min. through each of the sampling channels.

Clock relays were wired in series with the AC power lines from the generators. The air monitors were started at H - 6 hours to obtain a long background recording of the natural beta and gamma activities. After 17 hours of continuous running, the clock relays opened the circuit which cut off the main power to the air monitors but allowed the generators to remain running. This was done so that the filter paper supply would not run out if the pick-up party was delayed in collecting the samples.

~~CONFIDENTIAL~~

UNCLASSIFIED

~~CONFIDENTIAL~~
~~Security Information~~

UNCLASSIFIED

3.2.2 Collection and Shipment of Samples

Sample collections started between H + 6 and H + 12 hours. Filter paper sample rolls from the field stations were returned to Camp Mercury. Each roll, after at least one complete replay to check the original readings, was shipped by air to Army Chemical Center, Md., in order to check the validity of the original readings.

3.2.3 Treatment of Samples at Army Chemical Center, Maryland

Each air monitor was decontaminated, completely overhauled, and calibrated for beta and gamma geometry, coincidence, air path, and tube window thickness. Then the filter paper rolls were replayed at least three times through their respective air monitors.

3.2.4 Calibration Procedures

The sampling ports, through which the vacuum pump draws the air stream, have a diameter of 2.25 inches. Since the particulate sample is counted for activity at the same time the sample is collected, it was necessary to determine whether previous sample spots on the paper roll affected the GM tubes. This was done by determining whether the areas scanned by GM tube detectors were larger than the 2.25 inches of sampling area. As reported in the Operation JANGLE report, Project 2.5a-1, the amount of activity detected in excess of that from the 2.25-inch sample spots is less than 0.2 per cent of the total and can be disregarded.

In order to convert counts per minute into activity (microcuries) the following procedure was used:

Filter paper discs, having a 2.25-inch diameter, were soaked in an aqueous solution of a fission product mixture containing principally cerium, a beta emitter, and small amounts of other isotopes emitting a negligible amount of gamma radiation.

The above discs were then counted in a GM counter with a known geometry. After corrections for geometry, air path, and window thickness, the absolute beta and gamma activities were determined.

The calibrated discs were then placed directly over the sampling ports under the GM tube windows in the air monitors and the counting rates determined. Each air monitor was calibrated for beta and gamma counting efficiencies and the two tubes cross-calibrated.

~~CONFIDENTIAL~~
~~Security Information~~

UNCLASSIFIED

UNCLASSIFIED

~~CONFIDENTIAL~~

CHAPTER 4

RESULTS AND DISCUSSION

4.1 PORTABLE AIR SAMPLER, E-22

4.1.1 General

Although six sampling instruments were used in each of Operation SNAPPER Shots 5, 6, 7, and 8, it was not possible to obtain useful samples from all the instruments in every test. No data were obtained from Shot 5 because a wind and dust storm, which began before the sampling period was completed and lasted until 2200 on shot day, prevented the recovery of instruments until the following day. All filters had been exposed directly to winds up to 40 mi/hr for long periods after the initial sampling was completed, so that radioactive material was continually redistributed over the area after its original deposition. One sampling instrument had been blown over by the wind.

Figures 4.1, 4.2, and 4.3 show the locations of the stations relative to ground zero for Shots 6, 7, and 8 along with a rough indication of areas which became contaminated as a result of each detonation. Table 4.1 shows the placement of samplers at these stations along with the general activity level in mr/hr at the stations at the time of recovery of the instruments. All activity readings were obtained by using the "Rad-Safe" monitor's survey instrument.

The difficulty experienced in selecting stations which would prove to be in the proper position with respect to air-borne contamination is illustrated by the narrow corridors of contamination which resulted from Shots 7 and 8. It will be observed also that no new contamination occurred at any of the stations selected for Shot 8. However, meaningful data were collected from instruments at Stations 3 and 4 due to the fact that the previous shot, four days earlier, had contaminated this area. Instruments at these stations therefore sampled secondary aerosol stirred up by the shock wave, ordinary winds, and vehicular movement in the area. For this reason the results of Shot 8 will be discussed in the section on Secondary Aerosol Sampling.

Examination of Table 4.1 shows that samples obtained from four instruments in Shot 6, and two instruments each in Shots 7 and 8, should be expected to yield usable data. In every case, the samples, from stations at which there were no general area-readings, showed no contamination from air-borne material.

UNCLASSIFIED

~~CONFIDENTIAL~~

~~CONFIDENTIAL~~

UNCLASSIFIED

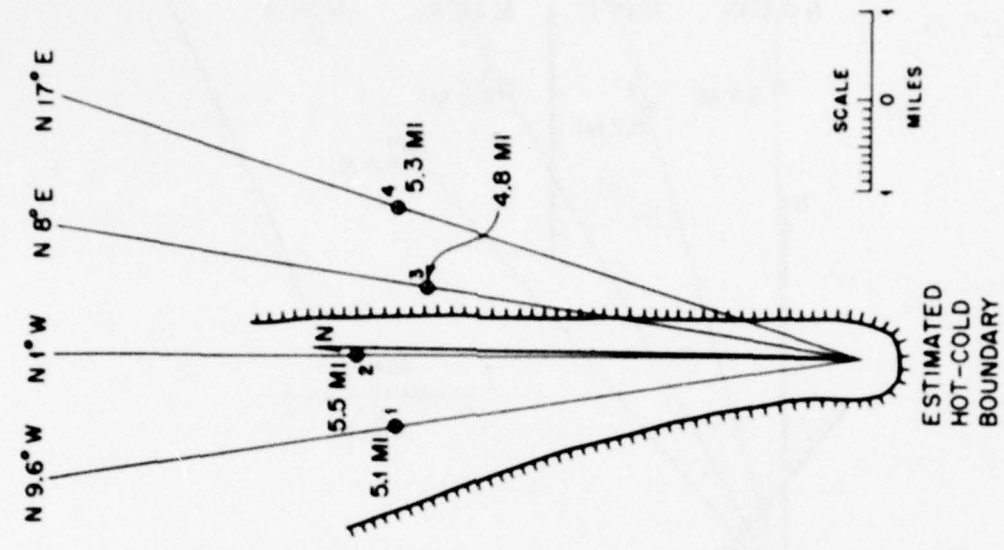

Fig. 4.2 Station Locations for Shot 7

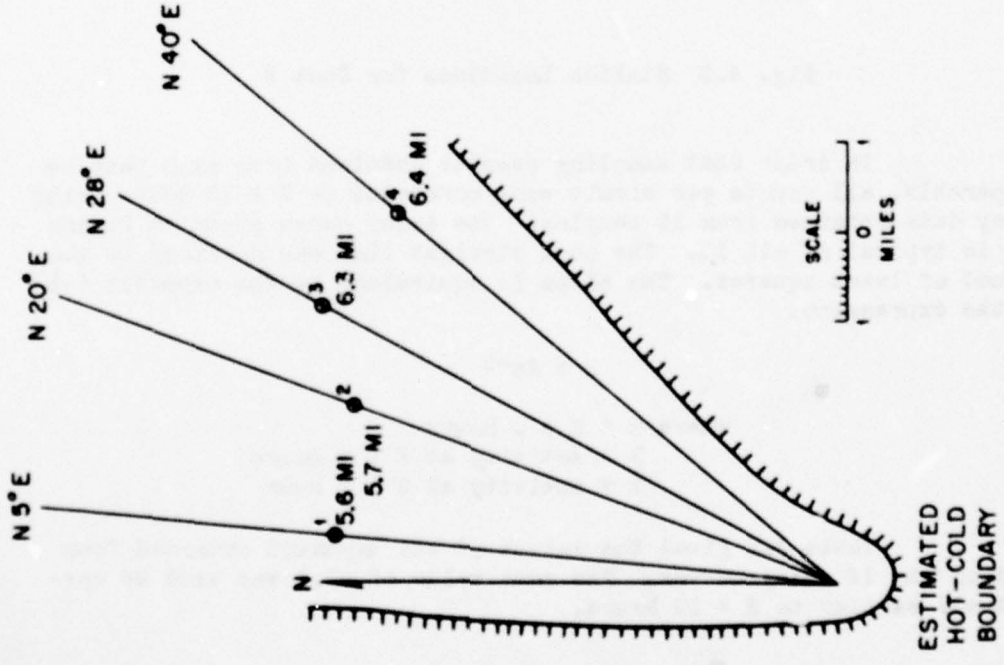

Fig. 4.1 Station Locations for Shot 6

~~CONFIDENTIAL~~

UNCLASSIFIED

UNCLASSIFIED

~~CONFIDENTIAL~~

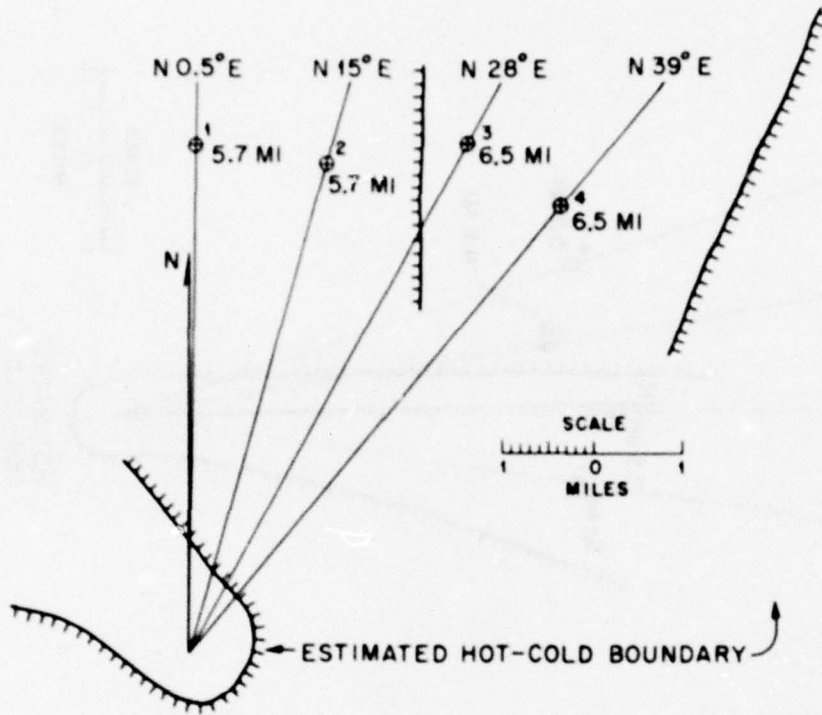

Fig. 4.3 Station Locations for Shot 8

In order that sampling results obtained from each test be comparable, all counts per minute were corrected to $H \pm 10$ hours using decay data obtained from 16 samples. The decay curve shown in Figure 4.4 is typical of all 16. The best straight line was obtained by the method of least squares. The slope is equivalent to the exponent $(-b)$ in the expression:

$$R = At^{-b}$$

where $t = H \pm t$ hours

$R =$ activity at $H \pm t$ hours

$A =$ activity at $H \pm 1$ hour

Table 4.2 gives the values of the exponent obtained from each of the 16 decay curves. The mean value of -1.1 was used to correct all samples to $H \pm 10$ hours.

UNCLASSIFIED

~~CONFIDENTIAL~~

~~CONFIDENTIAL~~

UNCLASSIFIED

TABLE 4.1

Location of Instruments at Stations for Shots 6, 7, and 8

Shot	Station	Instrument	Operation of Instrument	Station Activity Level at H + 8 hrs. (mr/hr)
6	1	6E	normal	18
	2	6B	uncertain	90
	2	6D	did not run	90
	3	6A	normal	1000
	3	6C	normal	1000
	4	6F	normal	600
7	1	7E	normal	5000
	2	7F	normal	1200
	3	7B	normal	0
	3	7D	normal	0
	4	7A	normal	0
	4	7C	normal	0
8	1	8B	normal	0
	1	8E	normal	0
	2	8A	normal	0
	2	8F	normal	0
	3	8C	normal	180*
4	8D	normal	250*	

* This contamination did not result from Shot 8 but was present as a result of previous shots.

TABLE 4.2

Values of b in the Expression $R = At^{-b}$

Sample	b	Sample	b
6A5	-1.0	6D15	-1.2
6A10	-1.2	6E8	-1.1
6B5	-1.0	6E11	-1.2
6B12	-1.0	6F4	-1.2
6C2	-1.2	6F14	-1.2
6C5	-1.2	7E1	-1.1
6C15	-1.1	7E8	-1.0
6D3	-1.2	7F1	-1.0

Mean Value = -1.1

UNCLASSIFIED

~~CONFIDENTIAL~~

UNCLASSIFIED

~~CONFIDENTIAL~~

4.1.2 Shot 6

As can be seen from Figure 4.1, all stations for this shot were within the area which became contaminated. The results are shown in Figures 4.5 through 4.9. Instruments 6A and 6B had all filter surfaces in the vertical plane as shown in Figure 2.2. All filters were exposed to the air for the entire sampling period. Instrument 6D did not operate and is therefore not included. Instruments 6C, 6E, and 6F had the filters in the horizontal plane with circular covers exposing one filter and its control at a time. (See Figure 2.4.) All instruments in this test used the molecular filter material.

Figures 4.5 and 4.6, for Instruments 6A and 6B respectively, show the random manner in which the collected activity varied from sample to sample. Also evident is the fact that the controls which were mounted in a manner identical to the other filters, but through which there was no air flow, did not agree with each other and in some cases were contaminated to a higher level than were many of the actual samples. For example, in Instrument 6A, one of the controls showed an activity level higher than seven of the 11 samples obtained, and in Instrument 6B one of the controls gave a higher reading than any of the samples.

Although the recorder failed to produce a trace for Instrument 6B, and thus provided no proof of the proper operation of the sampler, it appears that this instrument operated normally.

In Instruments 6C, 6E, and 6F random variations were also obtained as indicated in Figures 4.7, 4.8, and 4.9. In these cases also, the controls were frequently contaminated to a higher level than the corresponding samples.

It should be noted here that regardless of the precautions exercised in handling the MF filters, varying small amounts of material could be observed falling off the filter.

4.1.3 Shot 7

All samplers with filters in the vertical plane had been placed at Stations 3 and 4 as the stations most likely to be in the path of the radioactive aerosol. However, Stations 1 and 2 were the only ones which became contaminated.

Instrument 7E, at Station 1, had filters horizontal with a circular cover. The flow rate was approximately 2.5 liters per minute. Instrument 7F, at Station 2, had filter holders inverted with the open end pointing downward. In this case also, the orifice had been removed giving a flow rate of approximately 2.5 liters per minute. Both instruments used "Type 6" paper.

UNCLASSIFIED

~~CONFIDENTIAL~~

~~SECRET~~

UNCLASSIFIED

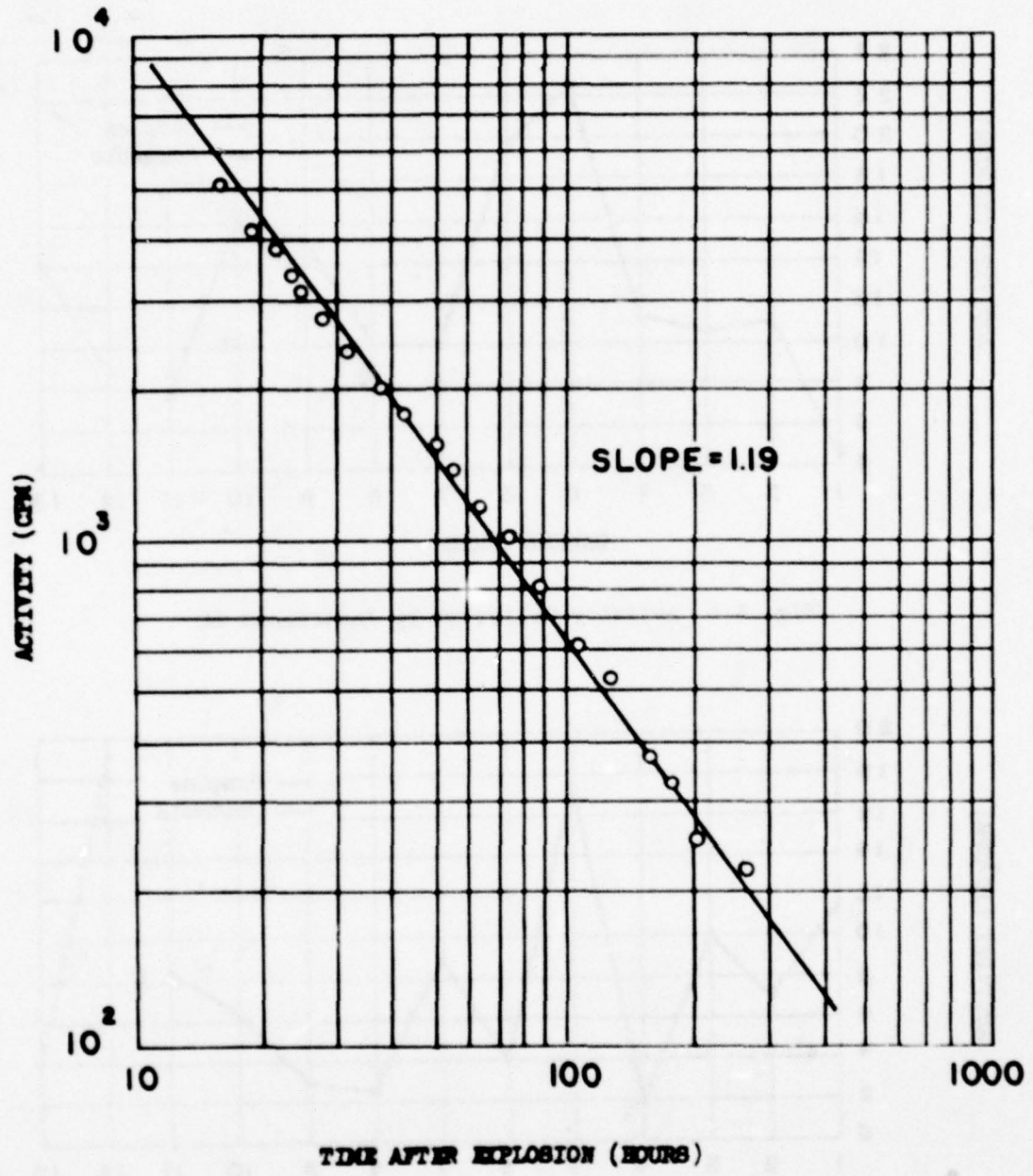

Fig. 4.4 Typical Decay Curve, Sample 6D15

~~SECRET~~

UNCLASSIFIED

UNCLASSIFIED

~~CONFIDENTIAL~~

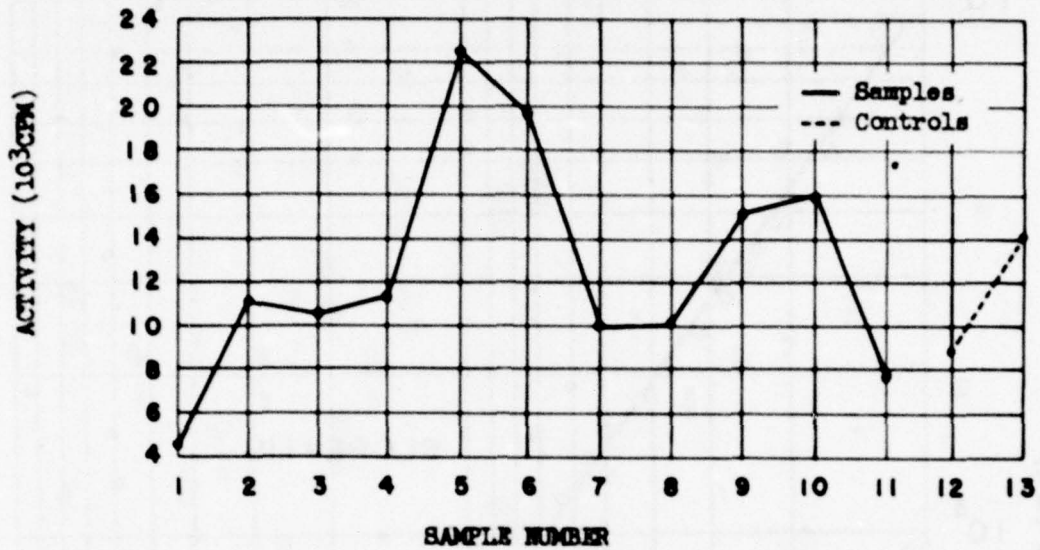

Fig. 4.5 Activity Collected by Instrument 6A

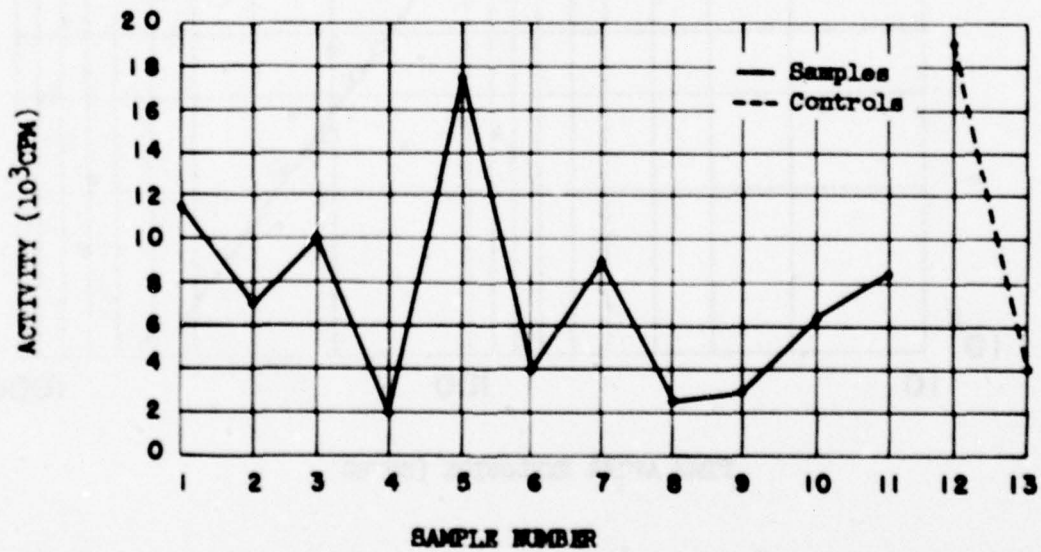

Fig. 4.6 Activity Collected by Instrument 6B

UNCLASSIFIED

~~CONFIDENTIAL~~

~~CONFIDENTIAL~~

UNCLASSIFIED

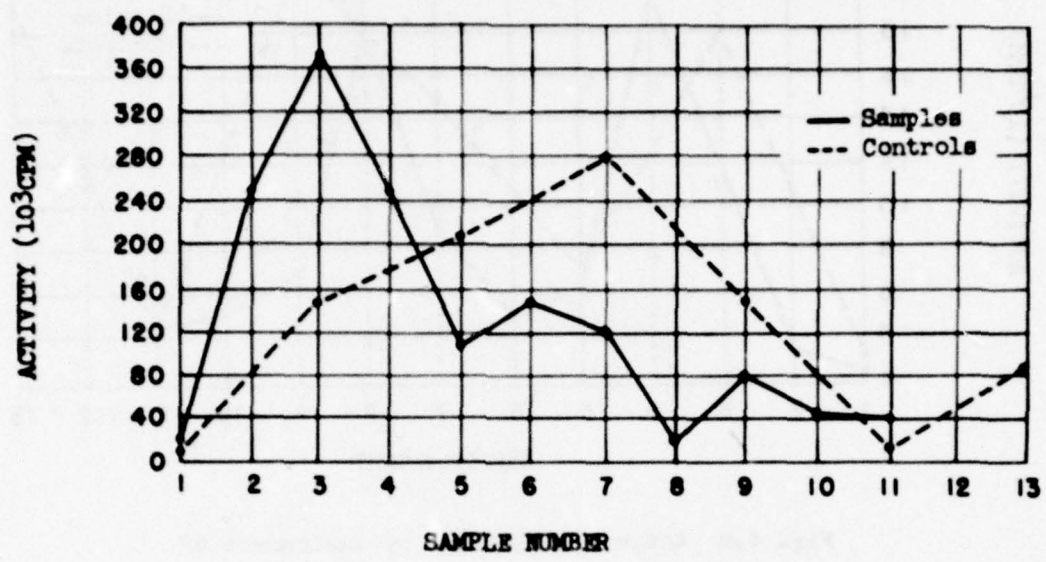

Fig. 4.7 Activity Collected by Instrument 6C

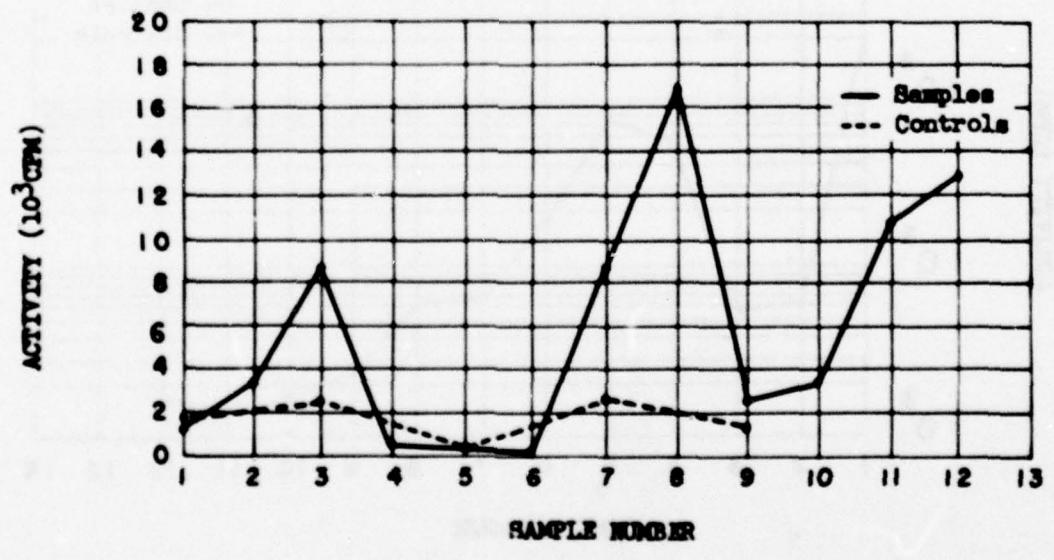

Fig. 4.8 Activity Collected by Instrument 6D

~~CONFIDENTIAL~~

UNCLASSIFIED

UNCLASSIFIED

~~CONFIDENTIAL~~

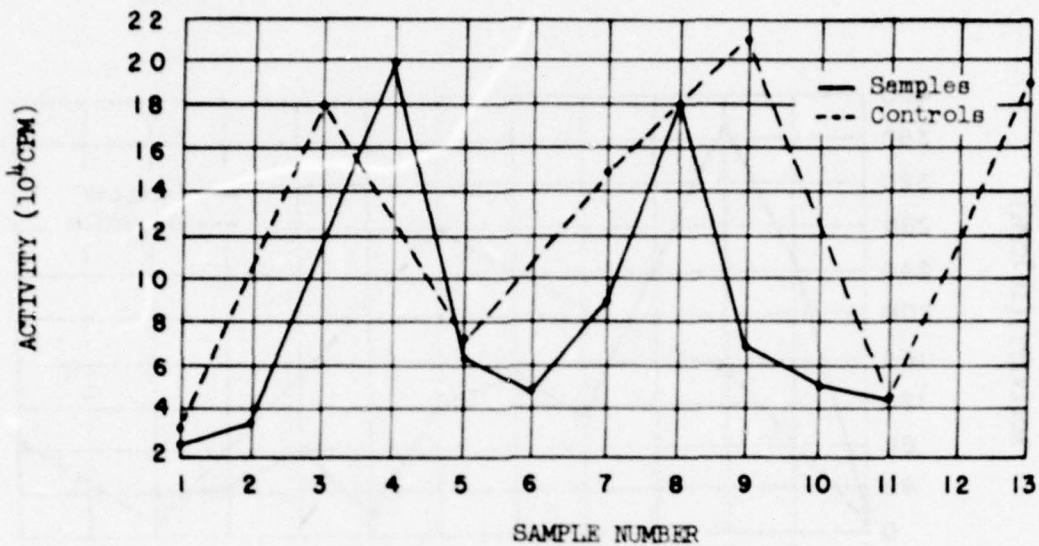

Fig. 4.9 Activity Collected by Instrument 6F

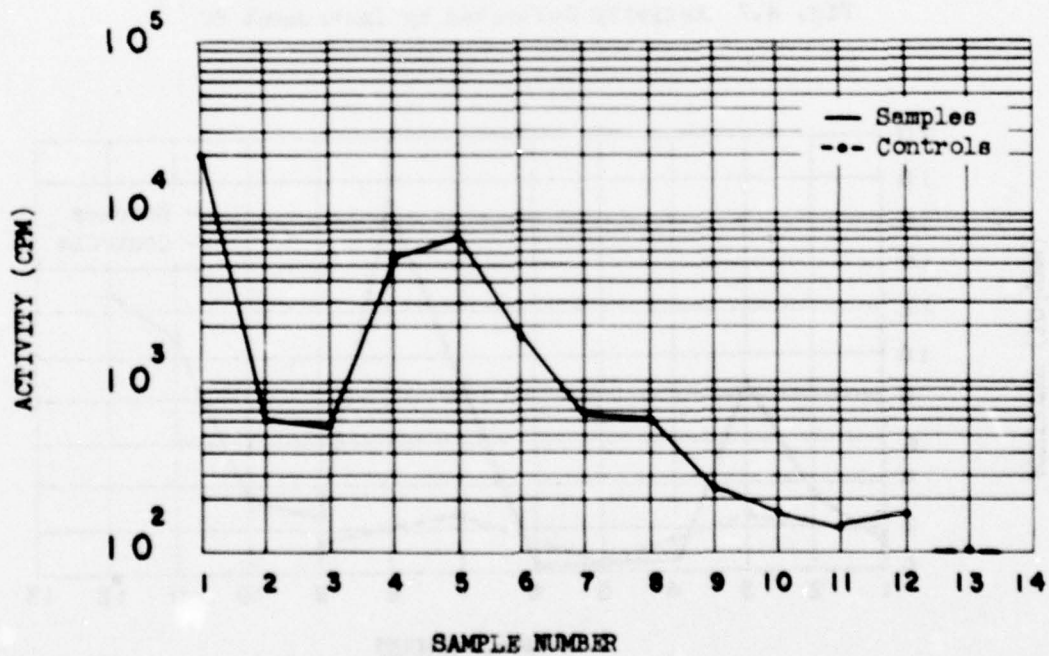

Fig. 4.10 Activity Collected by Instrument 7F with Inverted Filter Holders

UNCLASSIFIED

~~CONFIDENTIAL~~

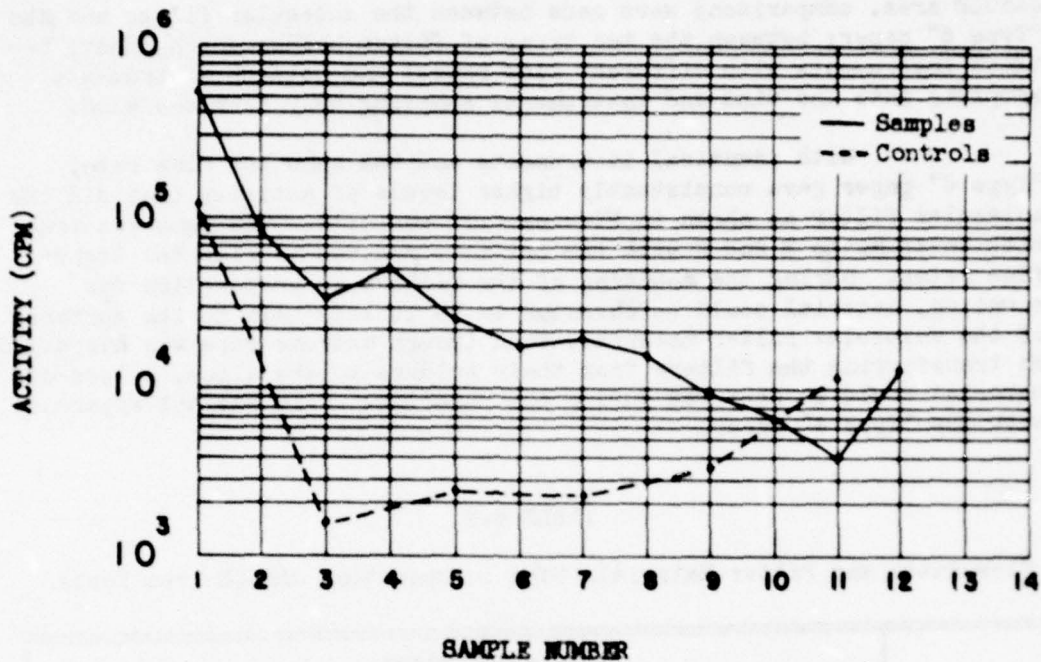

Fig. 4.11 Activity Collected by Instrument 7E

Figure 4.10 shows that with the filters in the inverted position the activity collected by the control was considerably lower than that in all samples through which air had been drawn. It is also evident that there was a more regular pattern of change of concentration with time than was the case with other arrangements in Shot 6. It should be noted, however, that even though the flow rate was increased and the general level of contamination of the area (1200 mr/hr) was higher than for any station in Shot 6, a smaller amount of activity was collected on the inverted filters.

Instrument 7E, which used the circular cover, a higher than normal flow rate, and "Type G" paper, also produced samples which showed a regular pattern of variation from sample to sample as shown in Fig. 4.11. Although the control filters gave relatively high counts, these counts were, with one exception, much lower than the actual samples.

The results obtained from each of these instruments indicate the desirability of using a higher flow rate than the one-half liter per minute provided by the orifice incorporated into the instrument.

4.1.4 Secondary Aerosol Sampling

In the sampling of secondary aerosol in the Operation

UNCLASSIFIED

~~CONFIDENTIAL~~

JANGLE area, comparisons were made between the molecular filter and the "Type 6" paper; between the two types of filter holder arrangement; between instruments with different flow rates; and between instruments sampling into the wind and instruments sampling away from the wind.

With identical instruments and the same low flow rate, "Type 6" paper gave consistently higher levels of activity than did the molecular filter as shown in Figures 4.12 and 4.13. The same was true with Instruments E and F with the orifices removed to give the higher flow rates. During the mounting of the filters in preparation for counting, material could be observed to be loosely held to the surface of the molecular filter material. Even though extreme care was exercised in transferring the filters from their holders to the slide, a loss of material could be observed during the handling. This was not apparent with the "Type 6" paper.

TABLE 4.3

Flow Rates and Filter Materials Used in Operation JANGLE Area Tests

Instrument	Sample Positions					
	1 to 4		5 to 8		9 and 10	
	Flow Rate l/min	Filter Material	Flow Rate l/min	Filter Material	Flow Rate l/min	Filter Material
A	0.5	MF	0.5	#6	0.5	#6
B	0.5	#6	0.5	#6	3.0	#6
C	0.5	MF	0.5	MF	0.5	MF
D	0.5	#6	0.5	#6	0.5	#6
E	3.0	MF	3.0	MF	3.0	MF
F	3.0	#6	3.0	#6	3.0	#6

All instruments were run simultaneously at the same station.

As expected, samples obtained from instruments having higher flow rates showed greater activity. Table 4.4 shows, however, that the ratio of activity collected is considerably greater than the ratio of flow rates.

Data from tests designed to determine the effect of wind direction are inconclusive because the surface wind direction continually shifted through 180 degrees during the period of the tests. Results are shown in Figure 4.14. Samples from neither of the instruments tested were consistently more active than those from the other.

During Shot 8, Instruments C and D, which were placed in a previously contaminated area at Stations 3 and 5, sampled secondary

UNCLASSIFIED

~~CONFIDENTIAL~~

~~CONFIDENTIAL~~

UNCLASSIFIED

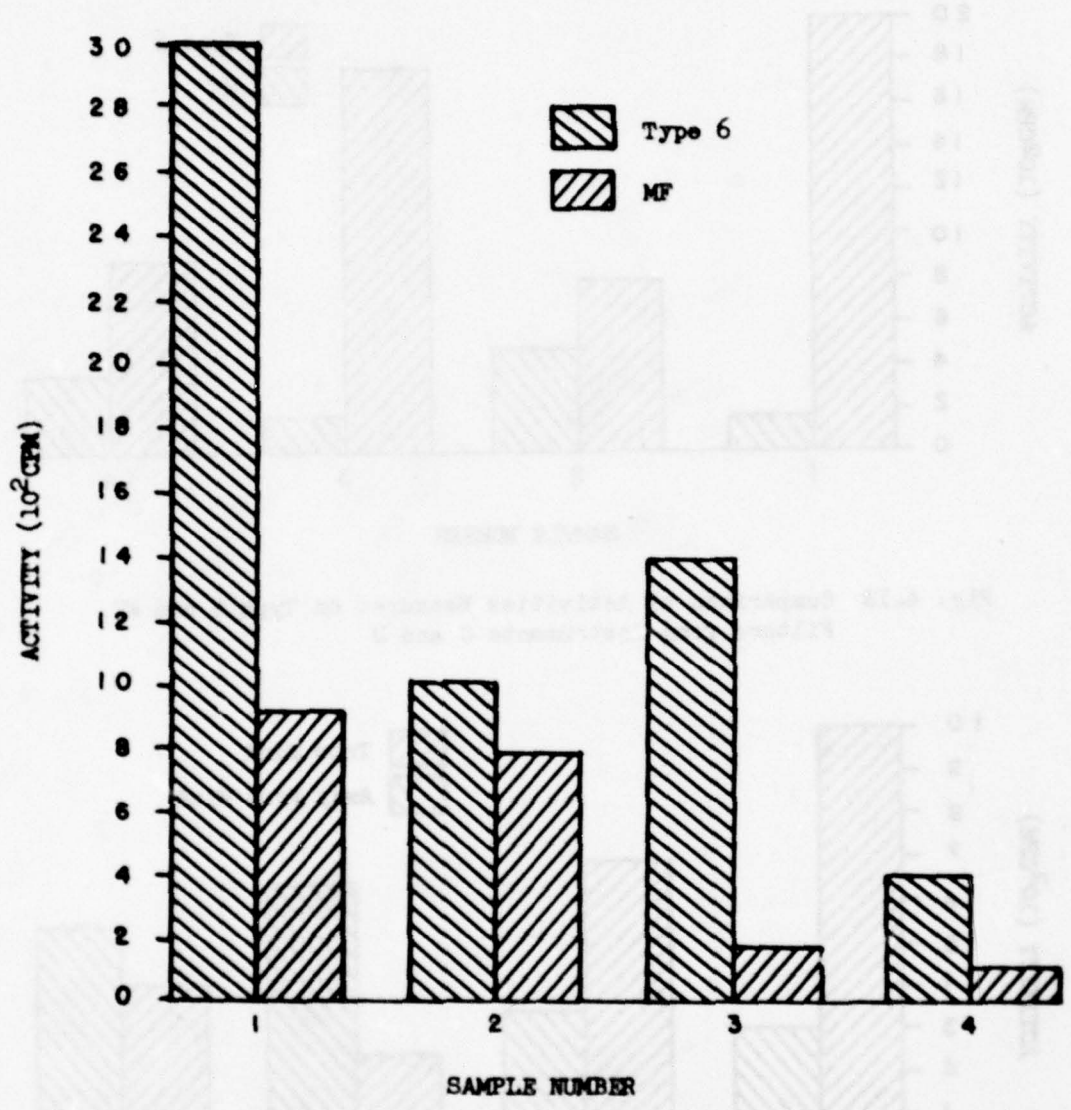

Fig. 4.12 Comparison of Activities Measured on Type 6 and MF Filters from Instruments A and B

~~CONFIDENTIAL~~

UNCLASSIFIED

UNCLASSIFIED

~~CONFIDENTIAL~~

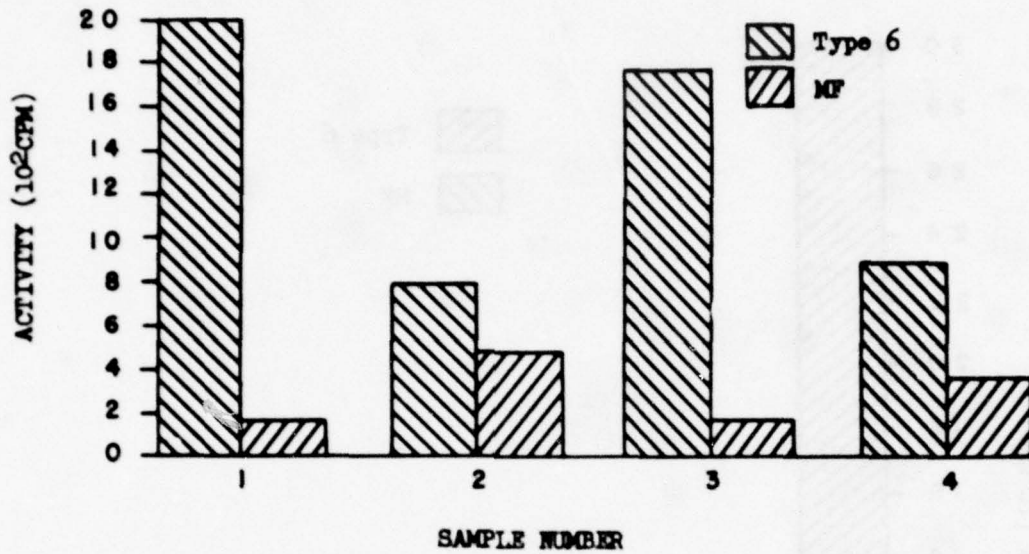

Fig. 4.13 Comparison of Activities Measured on Type 6 and MF Filters from Instruments C and D

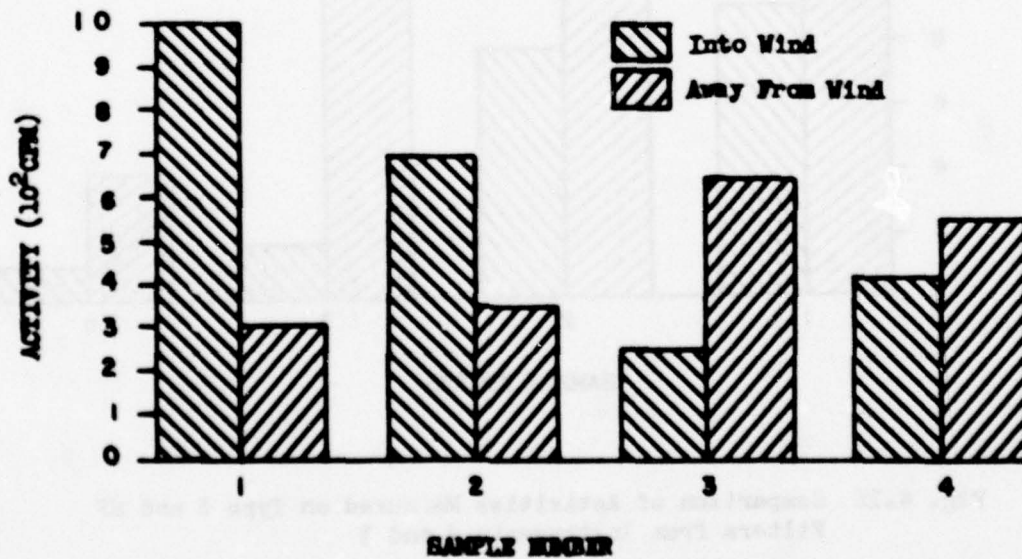

Fig. 4.14 Comparison of Activities Collected on Instruments Facing into Wind and Away from Wind

UNCLASSIFIED

~~CONFIDENTIAL~~

~~CONFIDENTIAL~~

UNCLASSIFIED

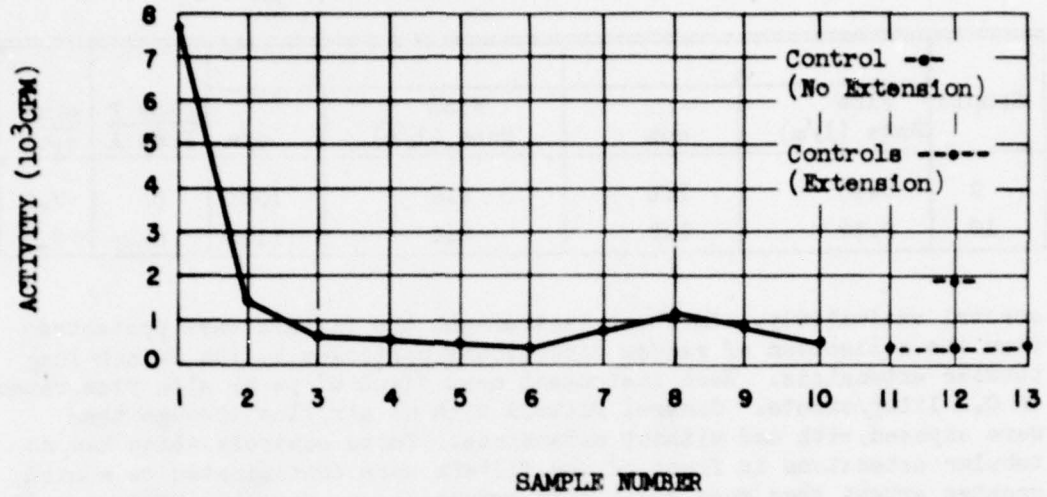

Fig. 4.15 Activity Collected by Instrument 8C with Tubular Extensions Mounted in Front of Filter Holders

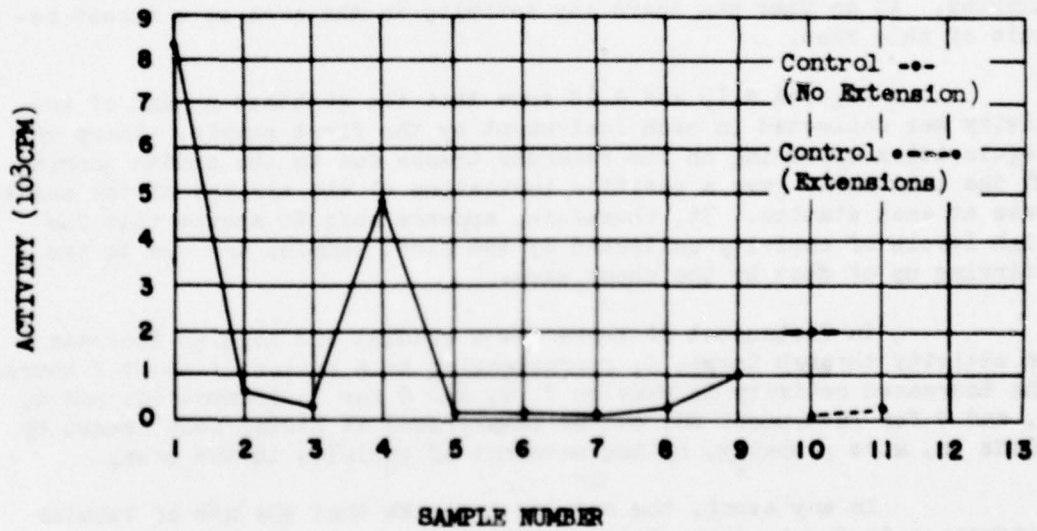

Fig. 4.16 Activity Collected by Instrument 8D with Tubular Extensions Mounted in Front of Filter Holders

~~CONFIDENTIAL~~

UNCLASSIFIED

UNCLASSIFIED

~~CONFIDENTIAL~~

TABLE 4.4

Comparison of Flow Rate with Activity Collected

Sample	A		B		Flow B Flow A	cpmB cpmA
	Flow Rate (l/m)	cpm	Flow Rate (l/m)	cpm		
9	0.48	131	2.4	1035	5	7.9
10	0.48	146	2.4	1100	5	7.5

aerosol exclusively. In these instruments the filters were protected from the collection of random directional particles by the 3-inch-long tubular extensions. Each instrument used "Type 6" paper with flow rates of 0.5 liter/minute. Control filters with no air flow through them were exposed with and without extensions. Those controls which had no tubular extensions in front of the filters were contaminated to a much greater extent than were those with extensions as shown in Figures 4.15 and 4.16.

Sampling began at H-6 minutes for Instrument C and at H-11 minutes for Instrument D. This means that Sample 1 for each instrument was being collected at the time of the detonation. Instrument C collected this sample until H + 14 minutes and Instrument D, until H + 9 minutes. At no time was there any activity in the area as a direct result of this shot.

Figures 4.15 and 4.16 show that the greatest amount of activity was collected in each instrument by the first sample. Sharp irregularities appearing on the recorder traces due to the sudden jarring of the instrument gave a positive indication of the arrival of the shock wave at each station. It, therefore, appears safe to assume that the high levels of activity collected by the first samples are due to the stirring up of dust by the shock wave.

In Instrument 8C there was a gradual and regular decrease in activity through Sample 6, corresponding to a period of about 2 hours. The increased activity in Samples 7, 8, and 9 for Instrument 8C, and 4, 8, and 9 for Instrument 8D, can be interpreted as having been caused by winds or, more probably, by the movement of vehicles in the area.

In any event, the results indicate that the use of tubular extensions in front of the filters will protect the filters from the collection of random directional particles. Also indicated is the fact that air-borne contamination is negligible except when caused by moderate to strong winds or by local disturbances in the area such as the

UNCLASSIFIED

~~CONFIDENTIAL~~

~~CONFIDENTIAL~~

UNCLASSIFIED

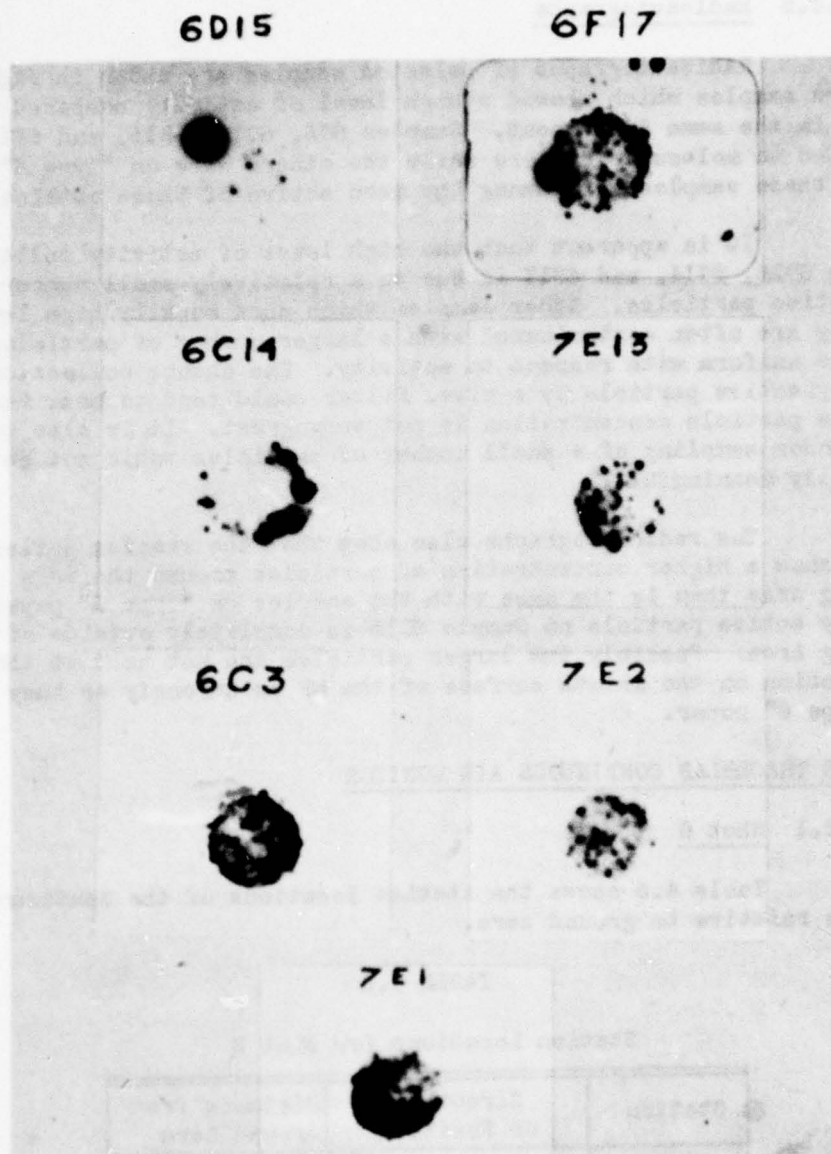

Fig. 4.17 Radioautographs of Selected Samples

~~CONFIDENTIAL~~

UNCLASSIFIED

UNCLASSIFIED

~~CONFIDENTIAL~~

movement of vehicles.

4.1.5 Radioautographs

Radioautographs of selected samples are shown in Figure 4.17. All were samples which showed a high level of activity compared to others in the same instrument. Samples 6C3, 6C14, 6D15, and 6F17 were collected on molecular filters while the others were on "Type 6" paper. All of these samples were among the more active of those obtained.

It is apparent that the high level of activity collected on Samples 6D15, 6C14, and 6F17 is due to a relatively small number of very active particles. Other samples which show equally high levels of activity are often contaminated with a larger number of particles which are more uniform with respect to activity. The chance collection of one very active particle by a given filter would tend to mask the fact that the particle concentration is not very great. It is also true that such random sampling of a small number of particles would not be statistically meaningful.

The radioautographs also show that the samples collected on the MF show a higher concentration of particles around the edge of the sampling area than is the case with the samples on "Type 6" paper. The one very active particle on Sample 6D15 is completely outside of the sampling area. Possibly the larger particles are not held at the point of impaction on the smooth surface of the MF as strongly as they are on the "Type 6" paper.

4.2 THE TRACERLAB CONTINUOUS AIR MONITOR

4.2.1 Shot 6

Table 4.5 shows the station locations of the Continuous Air Monitors relative to ground zero.

TABLE 4.5

Station Locations for Shot 6

Station	Direction or Position	Distance from Ground Zero
F-1	5° E. of North	5.6 miles
F-3	28° E. of North	6.5 miles
F-4	40° E. of North	6.4 miles
F-5	20° W. of South	12.0 miles
F-6	Camp Mercury	33.0 miles

For Shot 6, Stations F-1 through F-5 were in direct line of sight of ground zero. Stations F-1 and F-5 showed no noticeable increase

UNCLASSIFIED

~~CONFIDENTIAL~~

~~CONFIDENTIAL~~
UNCLASSIFIED

in activity above background. Stations F-3 and F-4 showed fall-out sufficient to cause the monitors to go off-scale within a few minutes after the detonation.

Station F-6, at Camp Mercury, furnished interesting data as shown in Figure 4.18. Figures 4.19 and 4.20 present the same data converted to microcuries per cubic centimeter of air. This station was allowed to operate for more than two days and the data indicate an appreciable increase in activity after H-hour.

Of interest also is the occurrence of the "pip" on the chart at or near H-hour (0500) as can be seen in Figures 4.18 and 4.19. The instrument at Camp Mercury is the only one of the instruments which showed this phenomenon. It may be noted also that the "pip" is evident on the beta plus gamma trace only. The occurrence of this "pip" is still unexplained.

4.2.2 Shot 7

The Tracerlab Continuous Air Monitors were located at stations as shown in Table 4.6.

TABLE 4.6

Station Locations for Shot 7

Station	Direction or Position	Distance from Ground Zero
G-1	45°E. of North	13 miles
G-2	30°E. of North	12.4 miles
G-3	11°E. of North	10.6 miles
G-4	15°W. of South	11 miles
G-5	Camp Mercury	33 miles
G-6	Camp Mercury	33 miles

Stations G-1 through G-3 were behind the mountain range and located just off the dirt roads leading to Groom Lake. Stations G-1 and G-2 received no increase in activity above normal background. It may be of interest to note that the background readings were from 6 to 12 mr/hr at these stations.

Station G-4 was located at the control point area and received no increase in activity. Stations G-5 and G-6, located in Camp Mercury, were outside and inside, respectively, of a quonset hut. Background readings were a little above normal due to fall-out from Shot 6, but there was no significant increase of activity after Shot 7. The only Shot-7 station providing any data was G-3, located at the top of the hill on the Groom Pass road. Figure 4.21 presents the beta concentration and Figure 4.22, the gamma concentration.

~~CONFIDENTIAL~~
UNCLASSIFIED

UNCLASSIFIED

~~CONFIDENTIAL~~

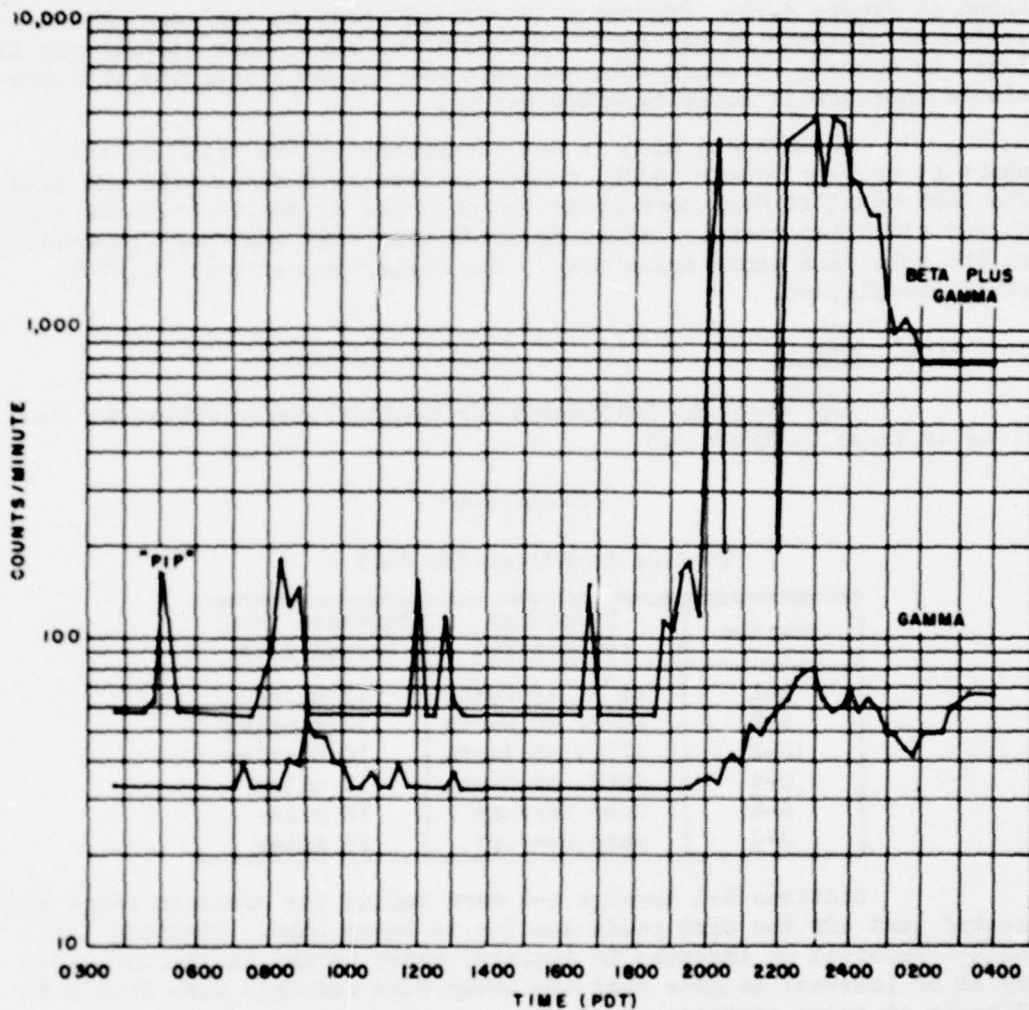

Fig. 4.18 Original Record, Station F-6 (Camp Mercury) Shot 6

UNCLASSIFIED

~~CONFIDENTIAL~~

~~CONFIDENTIAL~~

UNCLASSIFIED

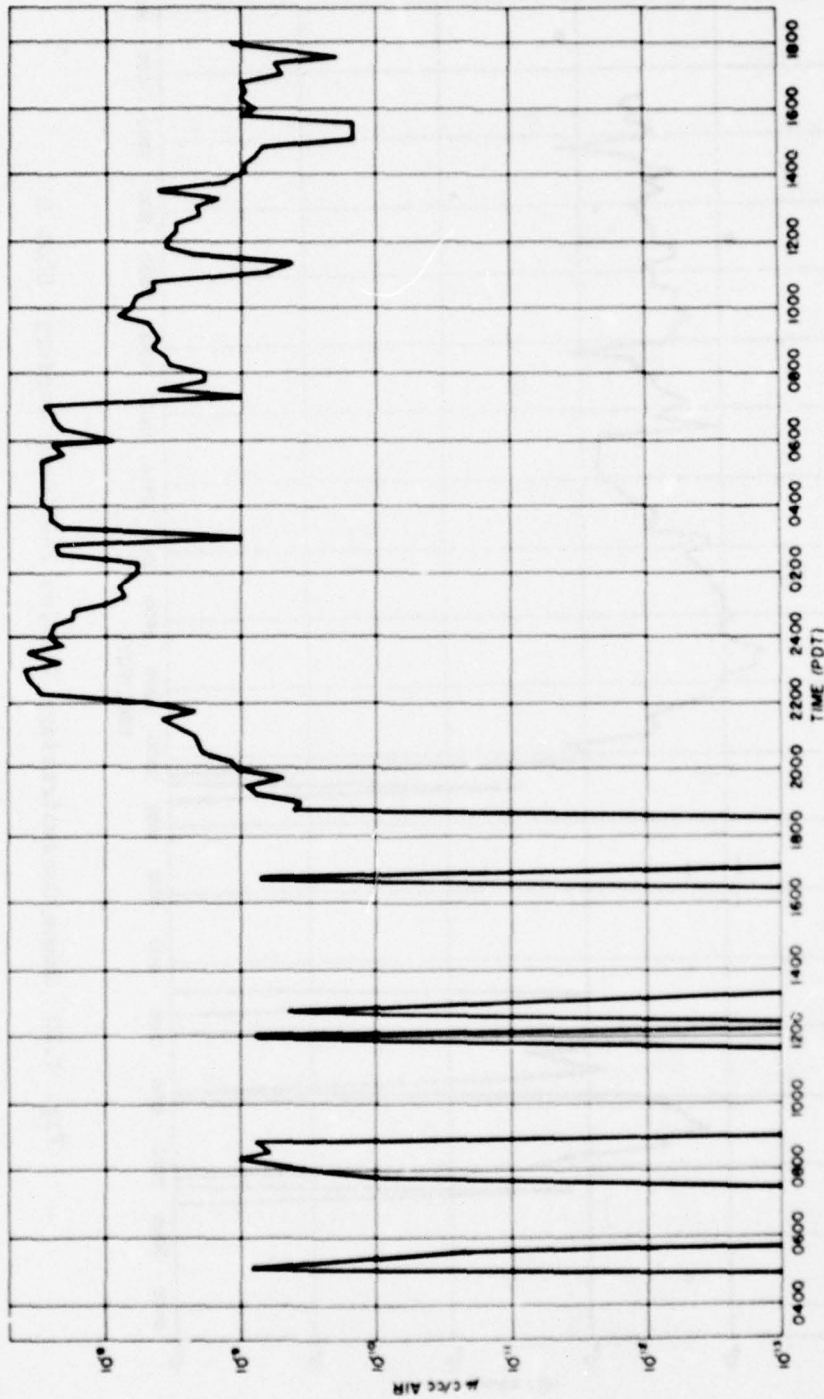

Fig. 4.19 Beta Concentration, Station F-6 (Camp Mercury) Shot 6

~~CONFIDENTIAL~~

UNCLASSIFIED

UNCLASSIFIED

~~CONFIDENTIAL~~

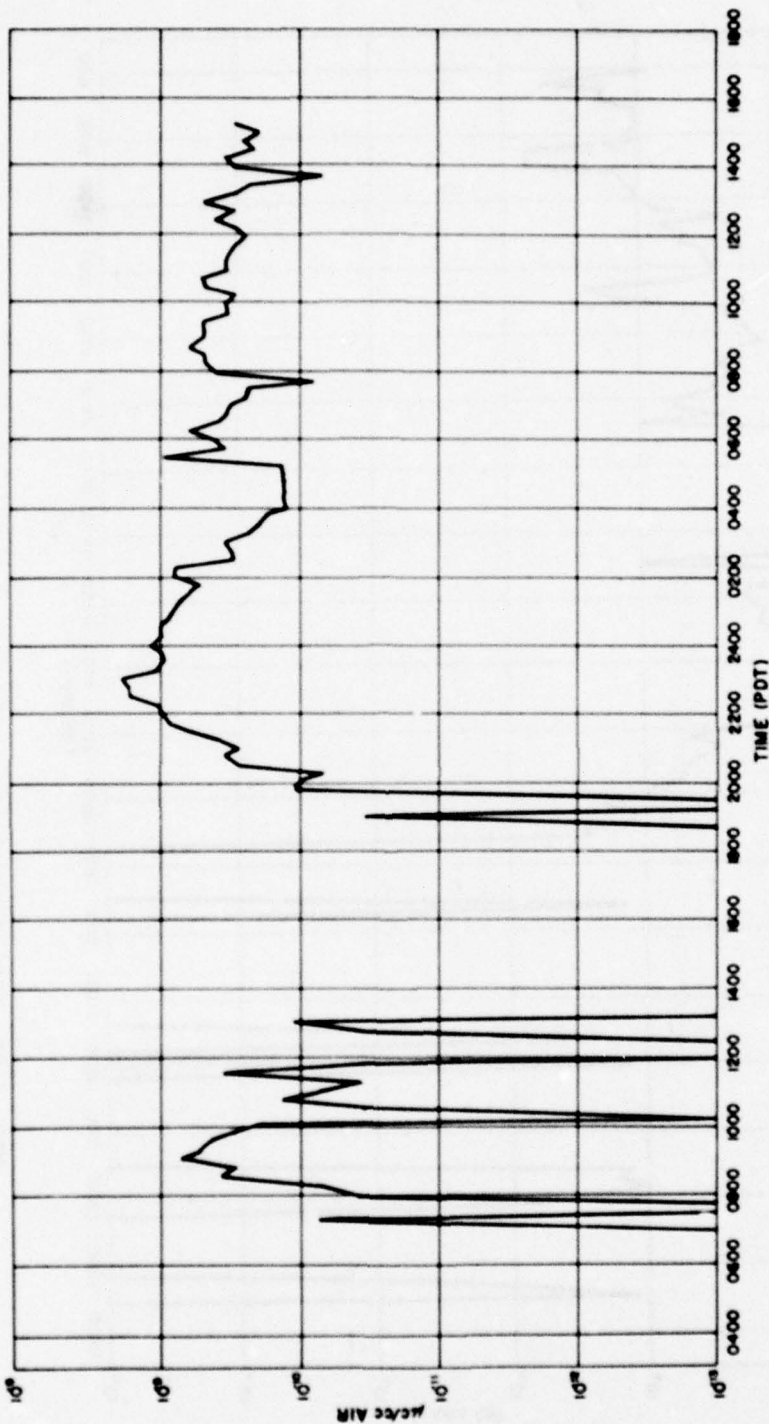

Fig. 4.20 Gamma Concentration, Station F-6 (Camp Mercury) Shot 6

UNCLASSIFIED

~~CONFIDENTIAL~~

~~CONFIDENTIAL~~

UNCLASSIFIED

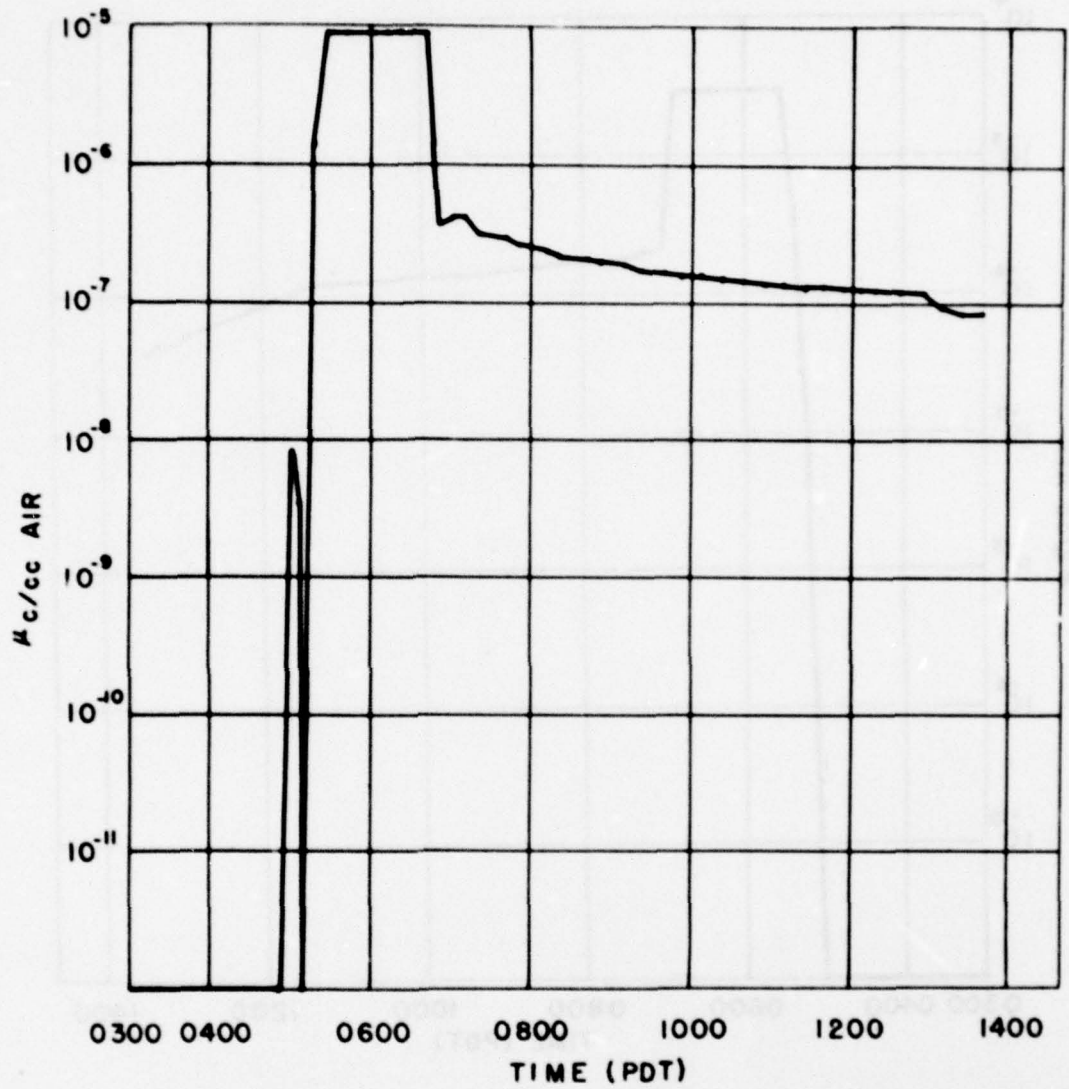

Fig. 4.21 Beta Concentration, Station G-3, Shot 7

~~CONFIDENTIAL~~

UNCLASSIFIED

UNCLASSIFIED

~~CONFIDENTIAL~~

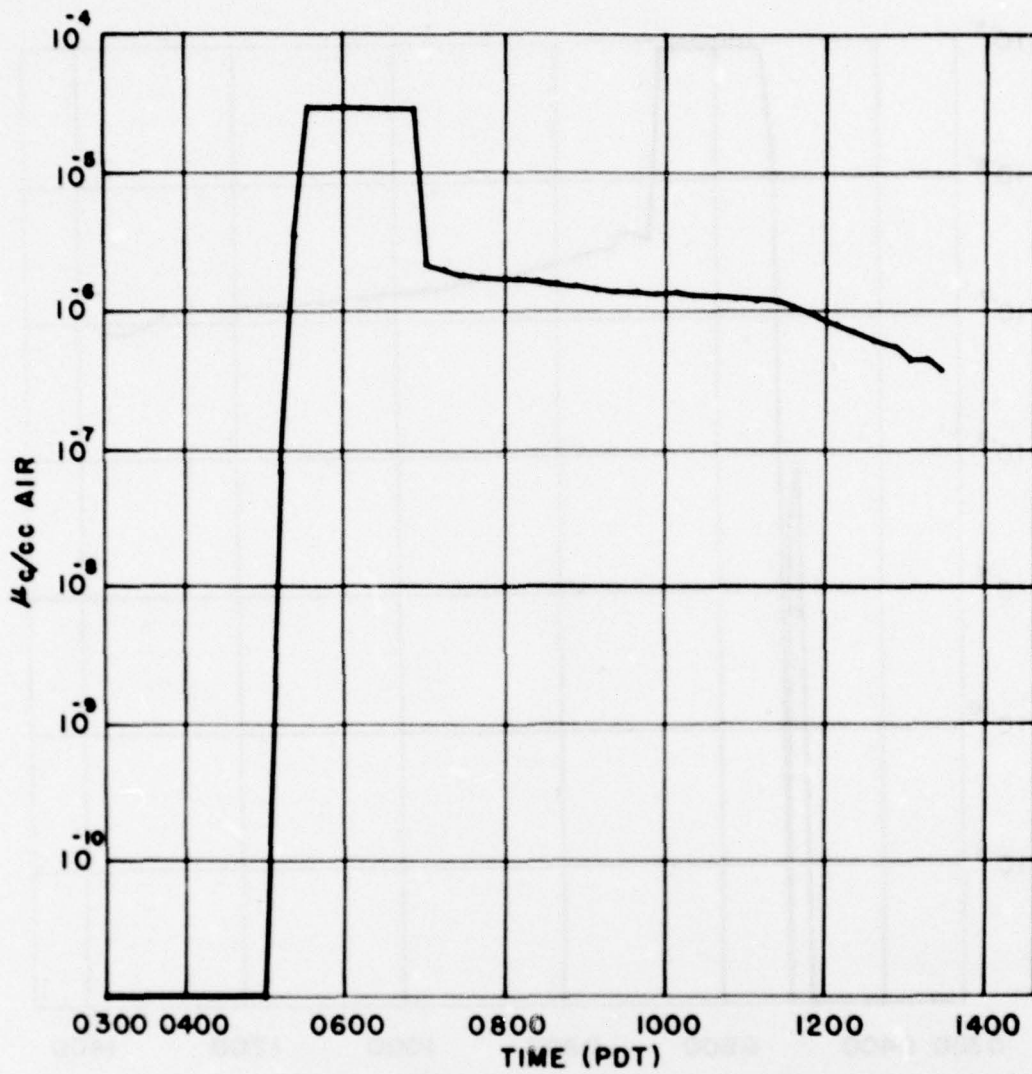

Fig. 4.22 Gamma Concentration, Station G-3, Shot 7

UNCLASSIFIED

~~CONFIDENTIAL~~

4.2.3 Evaluation of Hazard from Secondary Aerosols in the JANGLE Area

In order to evaluate the hazard resulting from the secondary aerosols generated by normal wind turbulence over the area of the underground and surface shots of Operation JANGLE (November, 1951), continuous air monitors were placed one mile north of the underground zero point and one mile east of the underground zero point. The two monitors were allowed to sample from 2000 hours on 22 May 1952 to 1400 hours, 23 May 1952. There was a general southwesterly wind estimated at 2 miles per hour. The gamma background at these two stations was so high that no significant data could be obtained as to the radiation resulting from the secondary aerosols. Shot 6 re-contaminated the JANGLE area, preventing any further tests of this nature.

4.2.4 Long Range Activity Detection

Prior to Operation SNAPPER, (during Operation TUMBLER) one continuous air monitor was installed at Army Chemical Center, Maryland, and allowed to monitor the air over a period of more than two weeks. It was hoped that the re-designed air monitor could be evaluated for long range detection of radioactivity from atomic cloud sources.

The first indication of extraordinary activity in the atmosphere was obtained at 1120 hours (EST), 17 April 1952. This increase in activity continued for more than 24 hours inasmuch as the general background did not return to its normal level until 1600 hours, 18 April 1952.

Since the activity collected was quite large, it was assumed that the activity source was a mixture of fission products originating from an atomic cloud which had passed overhead. An attempt was made to determine the approximate time of the nuclear detonation from the data furnished by the air monitor.

The accepted equation for the decay of fission product mixtures, $R = At^{-b}$, on differentiation, becomes

$$dR/dt = -bAt^{-b-1}$$

This differential equation divided by the original equation gives:

$$dR/dt = -Rbt^{-1}$$

Over short intervals of time, the above equation may be rewritten by replacing dR , dt , R , and t respectively, by their average values. The equation then becomes:

$$(R_1 - R_2)/(t_1 - t_2) = -b(R_1 + R_2)/(t_1 + t_2)$$

UNCLASSIFIED

~~CONFIDENTIAL~~

In this equation, R_1 and R_2 are the activity readings at t_1 and t_2 , respectively, hours after the bomb detonation. Assume that the constant, b , is 1.2.

The activity readings obtained with the air monitor were 134 at 1520 hours on 17 April and 77 at 1420 on 18 April.

Putting these values into the above equation gives:

$$(134 - 77)/(-23) = -1.2 (134 + 77)/(2t_1 + 23)$$

$$t_1 = 39.6 \text{ hrs.}$$

Consequently, the time of detonation was 39.6 hours before 1520 hours 17 April. This is 2344 hours (EST) or 2044 hours (PST) on 15 April.

4.2.5 Discussion of Results

Throughout the tests the Tracerlab Continuous Air Monitors were checked to determine whether the modifications made on the previous model eliminated the undesirable characteristics listed in Section 1.2.2. It was found that these modifications were satisfactory if the instrument is to be used only for the purpose for which it was designed, i.e. as a Health Physics tool for the laboratory sampling of aerosols. Operation SNAPPER has provided a convenient source of air-borne radioactive aerosol which has aided in the evaluation of the instrument with present modifications.

Although the monitor can be used in areas outside the laboratory which do not become too highly contaminated due to heavy fall-out for obtaining a record of beta plus gamma and gamma radiation from radioactive aerosols, the record is obtained with great difficulty. The heavy air pumps and the counting and recording units make the monitors bulky, delicate, and complex from the standpoint of field operations. They require a good AC power supply and must be protected from all adverse weather conditions.

The amount of activity deposited at field locations in the vicinity of an atomic detonation produces a sufficiently high background reading to drive the recorder off-scale even though the recorder is set on the highest scale. In spite of the fact that the monitor incorporates a gamma background counter so that corrections for the true collected activity can be made, there is still no means of detecting and measuring the amounts of external radiation under these high background conditions. This would indicate the need for additional shielding against high gamma fields before its use would be of value in these situations. Due to structural design of the monitors, it is impossible to add any more shielding to the already lead-shielded GM tubes. If the monitor were to

UNCLASSIFIED

~~CONFIDENTIAL~~

~~CONFIDENTIAL~~

UNCLASSIFIED

be used in any future tests involving high radiation fields, it would be necessary to construct shielded underground vaults to house the complete unit with sampling accomplished through pipes leading to the outside. This would prove impracticable from the standpoint of time and expense.

Several additional characteristics which make the Monitor undesirable from the standpoint of field use are:

1. The instrument cannot be decontaminated by washing with hot water or steam.
2. Time required for sample pick-up is excessive, constituting a hazard to pick-up teams.
3. Special type tools are required for assembly, sample pick-up, and roll-up operations.

~~CONFIDENTIAL~~

UNCLASSIFIED

UNCLASSIFIED

~~CONFIDENTIAL~~

CHAPTER 5

CONCLUSIONS AND RECOMMENDATIONS

5.1 PORTABLE AIR SAMPLER, E-22

5.1.1 Conclusions

The data obtained in Project 6.7 during Operation SNAPPER definitely show that the Portable Air Sampler, E-22, in its present form does not give meaningful or reliable results when used as a radiological air monitor. It is probable, however, that changes in the method of mounting and exposing filters may eliminate present difficulties.

The present method of mounting filters is unsatisfactory in that the filters are exposed directly to fall-out and wind-blown particles.

The flow rate is too low to give meaningful and reliable results, particularly in instances where the concentration of activity in the air is low or where the concentration of activity varies rapidly with time, necessitating shorter sampling periods.

Although the MF type filter is extremely efficient in removing particles from the air stream passing through it, retention of the particles on its surface was apparently inferior to that of the Chemical Corps Filter Material, Type 6.

5.1.2 Recommendations

It is recommended that a laboratory evaluation of the instrument be initiated in an attempt to determine conclusively whether variations in the manner of mounting filters will give reliable results with either the present 0.5 liters per minute sampling rate or with higher sampling rates. Such tests also will provide information which will allow standardization of the sampler in order that data can be interpreted quantitatively in terms of $\mu\text{c}/\text{cc}$ of air.

Possible successful arrangements of filter-holders which are suggested by the results obtained in this project are:

1. Plastic tubes, 3-inches long and $\frac{1}{2}$ -inch internal diameter extending from the face of the filter holders.
2. An arrangement in which an airtight head rotating about a horizontal axis would expose only one sample at a time without

UNCLASSIFIED

~~CONFIDENTIAL~~

~~CONFIDENTIAL~~

UNCLASSIFIED

allowing others to become contaminated in the process.

If laboratory tests indicate further usefulness, it is recommended that an easily controlled and accurate timing mechanism be developed for automatic operation of the rotary solenoid distributor.

5.2 THE TRACERLAB CONTINUOUS AIR MONITOR

5.2.1 Conclusions

Useful information can be obtained in the field from the continuous air monitor only at the expense of considerable time and effort in handling the bulky, delicate, and complex air monitor. Data are influenced by background radiation from which it is impractical to shield the instrument.

The modification in the paper drive mechanism which allows an aerosol sample to be collected on one spot on the filter paper during a known time interval simplifies the conversion of scale readings to activity concentration in microcuries per cubic centimeter of air sampled.

5.2.2 Recommendations

It is recommended that the Tracerlab Continuous Air Monitor be used only for the sampling of aerosols in the laboratory in keeping with the purpose for which it was designed and built and that no further consideration be given to its use in the field.

~~CONFIDENTIAL~~

UNCLASSIFIED

UNCLASSIFIED

~~CONFIDENTIAL~~

LIST OF REFERENCES

1. R. J. Bobka, A Report on Data from Operation JANGLE Obtained From a Radiological Air Sampler, CRLIR 112, Chemical and Radiological Laboratories, Army Chemical Center, Maryland
2. J. D. Wilcox et al., A Radiological Air Sampler - A Modification of a Portable Air Sampler, CRLIR 103, Chemical and Radiological Laboratories, Army Chemical Center, Maryland
3. Charles Robbins, Lt Col., Cml C., Air-borne Particle Studies, Operation JANGLE, Project 2.5a-1
4. G. Friedlander and J. W. Kennedy, Introduction to Radiochemistry, John Wiley and Sons, New York, p. 228
5. L. R. Zumwalt, Absolute Beta Counting Using End Window GM Counter Tubes, MDDC-1346, Technical Services Division, Oak Ridge National Laboratories

UNCLASSIFIED

~~CONFIDENTIAL~~

~~CONFIDENTIAL~~

UNCLASSIFIED

DISTRIBUTION

Copy No.

ARMY ACTIVITIES

Asst. Chief of Staff, G-2, D/A, Washington 25, D. C.	1
Asst. Chief of Staff, G-3, D/A, Washington 25, D. C.	
ATTN: DACofS, G-3 (RR&SW)	2
Asst. Chief of Staff, G-4, D/A, Washington 25, D. C.	3
Chief of Ordnance, D/A, Washington 25, D. C.	
ATTN: ORDTX-AR	4
Chief Signal Officer, D/A, P & O Division, Washington 25, D. C. ATTN: SIGOP	5- 7
The Surgeon General, D/A, Washington 25, D. C.	
ATTN: Chairman, Med R&D Board	8
Chief Chemical Officer, D/A, Washington 25, D. C.	9- 10
Chief of Engineers, D/A, Military Construction Division, Protective Construction Branch, Washington 25, D. C. ATTN: ENGEF	11
Chief of Engineers, D/A, Civil Works Division, Washington 25, D. C. ATTN: Engineering Division, Structural Branch	12
The Quartermaster General, CHR, Liaison Office, Research and Development Division, D/A, Washington 25, D. C.	13- 14
Office, Chief of Transportation, Military Planning and Intelligence Division, Building T-7, Washington 25, D. C.	15
Chief, Army Field Forces, Ft. Monroe, Va.	16- 19
Army Field Forces Board #1, Ft. Bragg, N. C.	20
Army Field Forces Board #4, Ft. Bliss, Tex.	21
Commanding General, First Army, Governor's Island, New York 4, N. Y. ATTN: G-1	22
Commanding General, First Army, Governor's Island, New York 4, N. Y. ATTN: G-2	23
Commanding General, First Army, Governor's Island, New York 4, N. Y. ATTN: G-3	24
Commanding General, First Army, Governor's Island, New York 4, N. Y. ATTN: G-4	25- 26
Commanding General, Second Army, Ft. George G. Meade, Md. ATTN: AIARB	27
Commanding General, Second Army, Ft. George G. Meade, Md. ATTN: AIAME	28
Commanding General, Second Army, Ft. George G. Meade, Md. ATTN: AIACM	29
Commanding General, Third Army, Ft. McPherson, Ga. ATTN: ACofS, G-3	30- 31
Commanding General, Fourth Army, Ft. Sam Houston, Tex. ATTN: G-3 Section	32- 33

~~CONFIDENTIAL~~

UNCLASSIFIED

DISTRIBUTION (Continued)

Copy No.

Commanding General, Fifth Army, 1660 E. Hyde Park Blvd., Chicago 15, Ill. ATTN: ALFUM	34
Commanding General, Fifth Army, 1660 E. Hyde Park Blvd., Chicago 15, Ill. ATTN: ALFGA-MS	35
Commanding General, Fifth Army, 1660 E. Hyde Park Blvd., Chicago 15, Ill. ATTN: ALFEN	36
Commanding General, Fifth Army, 1660 E. Hyde Park Blvd., Chicago 15, Ill. ATTN: ALFMD-0	37- 40
Commanding General, Fifth Army, 1660 E. Hyde Park Blvd., Chicago 15, Ill. ATTN: ALFHQ	41
Commanding General, Sixth Army, Presidio of San Francisco, Calif. ATTN: AMGCT-4	42
Commander-in-Chief, European Command, APO 403, c/o FM, New York, N. Y.	43
Commander-in-Chief, Far East Command, APO 500, c/o FM, San Francisco, Calif. ATTN: ACofS, G-3	44- 48
Commanding General, U. S. Army Europe, APO 403, c/o FM, New York, N. Y. ATTN: OPOT Div., Combat Dev. Branch	49- 50
Commanding General, U. S. Forces Austria, APO 168, c/o FM, New York, N. Y. ATTN: ACofS, G-3	51
Commanding General, U. S. Army Alaska, APO 942, c/o FM, Seattle, Wash.	52
Commanding General, U. S. Army Caribbean, APO 834, c/o FM, New Orleans, La. ATTN: CG, USARCARI B	53
Commanding General, U. S. Army Caribbean, APO 834, c/o FM, New Orleans, La. ATTN: CG, USARFANT	54
Commanding General, U. S. Army Caribbean, APO 834, c/o FM, New Orleans, La. ATTN: Cml Off, USARCARI B	55
Commanding General, U. S. Army Caribbean, APO 834, c/o FM, New Orleans, La. ATTN: Surgeon, USARCARI B	56
Commanding General, U. S. Army Pacific, APO 958, c/o FM, San Francisco, Calif. ATTN: Cml Off	57- 58
Commanding General, Trieste U. S. Troops, APO 209, c/o FM, New York, N. Y. ATTN: ACofS, G-3	59- 61
Commandant, Command and General Staff College, Ft. Leavenworth, Kan. ATTN: ALLIS(AS)	62
Commandant, Army War College, Carlisle Barracks, Pa. ATTN: Library	63
Commandant, The Infantry School, Ft. Benning, Ga. ATTN: C.D.S.	64- 65
Commandant, The Artillery School, Ft. Sill, Okla.	66
Commandant, The AA&GM Branch, The Artillery School, Ft. Bliss, Tex.	67
Commandant, The Armored School, Ft. Knox, Ky. ATTN: Classified Document Section, Evaluation and Research Division	68- 69
Commanding General, Medical Field Service School, Brooke Army Medical Center, Ft. Sam Houston, Tex.	70

~~CONFIDENTIAL~~

UNCLASSIFIED

DISTRIBUTION (Continued)

Copy No.

Commandant, Army Medical Service Graduate School, Walter Reed Army Medical Center, Washington 25, D. C. ATTN: Dept. of Biophysics	71
The Superintendent, U. S. Military Academy, West Point, N. Y. ATTN: Professor of Ordnance	72
Commandant, Chemical Corps School, Chemical Corps Training Command, Ft. McClellan, Ala.	73
Commanding General, Research and Engineering Command, Army Chemical Center, Md. ATTN: Special Projects Officer	74- 75
Commanding General, The Transportation Center and Ft. Eustis, Ft. Eustis, Va. ATTN: Asst. Commandant, Military Sciences and Tactics	76
Commanding General, The Engineer Center, Ft. Belvoir, Va. ATTN: Asst. Commandant, The Engineer School	77- 79
Chief of Research and Development, D/A, Washington 25, D. C.	80
Commanding Officer, Transportation Research and Development Station, Ft. Eustis, Va.	81
Commanding Officer, Engineer Research and Development Laboratory, Ft. Belvoir, Va. ATTN: Chief, Tech. Intelligence Branch	82
Commanding Officer, Picatinny Arsenal, Dover, N. J. ATTN: ORDEB-TK	83
Commanding Officer, Frankford Arsenal, Philadelphia 37, Pa. ATTN: RD Control Officer	84
Commanding Officer, Army Medical Research Laboratory, Ft. Knox, Ky.	85
Commanding Officer, Chemical Corps Chemical and Radiological Laboratory, Army Chemical Center, Md. ATTN: Tech. Library	86- 87
Director, Technical Documents Center, Evans Signal Laboratory, Belmar, N. J.	88
Director, Waterways Experiment Station, PO Box 631, Vicksburg, Miss. ATTN: Library	89
Director, Operations Research Office, Johns Hopkins University, 6410 Connecticut Ave., Chevy Chase, Md. ATTN: Library	90

NAVY ACTIVITIES

Chief of Naval Operations, D/N, Washington 25, D. C. ATTN: OP-36	91- 92
Chief of Naval Operations, D/N, Washington 25, D. C. ATTN: OP-51	93
Chief of Naval Operations, D/N, Washington 25, D. C. ATTN: OP-53	94

~~CONFIDENTIAL~~

UNCLASSIFIED

UNCLASSIFIED

~~CONFIDENTIAL~~

DISTRIBUTION (Continued)

Copy No.

Chief, Bureau of Medicine and Surgery, D/N, Washington 25, D. C. ATTN: Special Weapons Defense Division	95- 96
Chief, Bureau of Ordnance, D/N, Washington 25, D. C.	97
Chief, Bureau of Personnel, D/N, Washington 25, D. C. ATTN: Pers 15	98
Chief, Bureau of Personnel, D/N, Washington 25, D. C. ATTN: Pers C123	99
Chief, Bureau of Personnel, D/N, Washington 25, D. C. ATTN: Pers C	100
Chief, Bureau of Ships, D/N, Washington 25, D. C. ATTN: Code 348	101-102
Chief, Bureau of Supplies and Accounts, D/N, Washington 25, D. C.	103
Chief, Bureau of Yards and Docks, D/N, Washington 25, D. C. ATTN: P-312	104
Chief, Bureau of Aeronautics, D/N, Washington 25, D. C.	105-106
Commander-in-Chief, U. S. Atlantic Fleet, Fleet Post Office, New York, N. Y.	107-108
Commander-in-Chief, U. S. Pacific Fleet, Fleet Post Office, San Francisco, Calif.	109-110
Commander, Operational Development Force, U. S. Atlantic Fleet, USN Base, Norfolk 11, Va. ATTN: Tactical Dev. Group	111
Commandant, U. S. Marine Corps, Headquarters, USMC, Washington 25, D. C. ATTN: Code AO3H	112-115
President, U. S. Naval War College, Newport, Rhode Island	116
Superintendent, USN Postgraduate School, Monterey, Calif.	117
Commanding Officer, USN Schools Command, Naval Station, Treasure Island, San Francisco, Calif.	118-119
Director, USMC Development Center, USMC Schools, Quantico, Va. ATTN: Marine Corps, Tactics Board	120
Director, USMC Development Center, USMC Schools, Quantico, Va. ATTN: Marine Corps, Equipment Board	121
Commanding Officer, Fleet Training Center, Naval Base, Norfolk 11, Va. ATTN: Special Weapons School	122
Commanding Officer, Fleet Training Center, (SFWP School), Naval Station, San Diego 36, Calif.	123
Commander, Air Force, U. S. Pacific Fleet, Naval Air Station, San Diego, Calif.	124
Commander, Training Command, U. S. Pacific Fleet, c/o Fleet Sonar School, San Diego 47, Calif.	125
Commanding Officer, Naval Damage Control Training Center, USN Base, Philadelphia 12, Pa. ATTN: ABC Defense Course	126
Commanding Officer, Naval Unit, Chemical Corps School, Ft. McClellan, Ala.	127
Commander, USN Ordnance Laboratory, Silver Spring 19, Md. ATTN: E	128

UNCLASSIFIED

~~CONFIDENTIAL~~

~~CONFIDENTIAL~~ UNCLASSIFIED

DISTRIBUTION (Continued)

Copy No.

Commander, USN Ordnance Laboratory, Silver Spring 19, Md. ATTN: EE	129
Commander, USN Ordnance Laboratory, Silver Spring 19, Md. ATTN: Alias	130
Commander, USN Ordnance Laboratory, Silver Spring 19, Md. ATTN: Aliex	131
Commander, USN Ordnance Test Station, Inyokern, China Lake, Calif.	132
Officer-in-Charge, USN Civil Engineering Research and Evaluation Laboratory, Construction Battalion Center, Port Hueneme, Calif. ATTN: Code 753	133-134
Commanding Officer, USN Medical Research Institute, National Naval Medical Center, Bethesda 14, Md.	135
Director, USN Research Laboratory, Washington 25, D. C.	136
Commanding Officer and Director, USN Electronics Labo- ratory, San Diego 52, Calif. ATTN: Code 250	137
Commanding Officer and Director, USN Electronics Labo- ratory, San Diego 52, Calif. ATTN: Code 310	138
Commanding Officer and Director, USN Engineering Experiment Station, Annapolis, Md. ATTN: Code 155	139
Commanding Officer, USN Radiological Defense Laboratory, San Francisco, Calif. ATTN: Technical Information Division	140-143
Commanding Officer and Director, David W. Taylor Model Basin, Washington 7, D. C. ATTN: Library	144
Commander, Naval Air Development Center, Johnsville, Pa.	145
Commanding Officer, Office of Naval Research Branch Office, 1000 Geary St., San Francisco, Calif.	146-147
Commanding Officer, USN Photographic Center, USN Air Station, Anacostia, D. C.	148-149

AIR FORCE ACTIVITIES

Special Asst. to Chief of Staff, Headquarters, USAF, Rm 5E1019, Pentagon, Washington 25, D. C.	150
Asst. for Atomic Energy, Headquarters, USAF, Washington 25, D. C. ATTN: DCS/O	151
Asst. for Atomic Energy, Headquarters, USAF, Washington 25, D. C. ATTN: BW&CW Division	152
Asst. for Development Planning, Headquarters, USAF, Washington 25, D. C.	153-154
Director of Operations, Headquarters, USAF, Washington 25, D. C.	155-156
Director of Plans, Headquarters, USAF, Washington 25, D. C. ATTN: War Plans Division	157
Directorate of Requirements, Headquarters, USAF, Washing- ton 25, D. C. ATTN: AFDRQ-SA/M	158

~~CONFIDENTIAL~~ UNCLASSIFIED

UNCLASSIFIED

~~CONFIDENTIAL~~

DISTRIBUTION (Continued)

Copy No.

Directorate of Research and Development, Headquarters, USAF, Armament Division, DCS/D, Washington 25, D. C.	159
Directorate of Intelligence, Headquarters, USAF, Wash- ington 25, D. C.	160-161
The Surgeon General, Headquarters, USAF, Washington 25, D. C.	162-163
Commanding General, U. S. Air Forces Europe, APO 633, c/o FM, New York, N. Y.	164
Commanding General, Far East Air Forces, APO 925, c/o FM, San Francisco, Calif.	165
Commanding General, Alaskan Air Command, APO 942, c/o FM, Seattle, Wash. ATTN: AAOTN	166-175
Commanding General, Northeast Air Command, APO 862, c/o FM, New York, N. Y.	176
Commanding General, Strategic Air Command, Offutt AFB, Omaha, Neb. ATTN: Chief, Operations Analysis	177
Commanding General, Tactical Air Command, Langley AFB, Va. ATTN: Documents Security Branch	178-180
Commanding General, Air Defense Command, Ent AFB, Colo.	181-182
Commanding General, Air Materiel Command, Wright-Patter- son AFB, Dayton, Ohio	183-185
Commanding General, Air Training Command, Scott AFB, Belleville, Ill.	186-187
Commanding General, Air Research and Development Command, PO Box 1395, Baltimore 3, Md. ATTN: RDDN	188-190
Commanding General, Air Proving Ground Command, Eglin AFB, Fla. ATTN: AG/TRB	191
Commanding General, Air University, Maxwell AFB, Ala.	192-196
Commandant, Air Command and Staff College, Maxwell AFB, Ala.	197-198
Commandant, Air Force School of Aviation Medicine, Ran- dolph AFB, Tex.	199-200
Commanding General, Wright Air Development Center, Wright- Patterson AFB, Dayton, Ohio. ATTN: WCOESP	201-203
Commanding General, AF Cambridge Research Center, 230 Albany St., Cambridge 39, Mass. ATTN: Atomic Warfare Directorate	204
Commanding General, AF Cambridge Research Center, 230 Albany St., Cambridge 39, Mass. ATTN: CRTSL-2	205
Commanding General, AF Special Weapons Center, Kirtland AFB, N. Mex. ATTN: Chief, Technical Library	206-208
Commandant, USAF Institute of Technology, Wright-Patterson AFB, Dayton, Ohio. ATTN: Resident College	209
Commanding General, Lowry AFB, Denver, Colo. ATTN: Dept. of Armament Training	210-211
Commanding General, 1009th Special Weapons Squadron, 1712 G St., NW, Washington 25, D. C.	212-214
The RAND Corporation, 1500-4th St., Santa Monica, Calif.	215-216

UNCLASSIFIED

~~CONFIDENTIAL~~

UNCLASSIFIED

DISTRIBUTION (Continued)

Copy No.

OTHER DEPT. OF DEFENSE ACTIVITIES

Executive Secretary, Joint Chiefs of Staff, Washington 25, D. C. ATTN: Joint Strategic Plans Committee	217
Director, Weapons Systems Evaluation Group, OSD, Rm 2E1006, Pentagon, Washington 25, D. C.	218
Asst. for Civil Defense, OSD, Washington 25, D. C.	219
Chairman, Research and Development Board, D/D, Washington 25, D. C. ATTN: Technical Library	220
Executive Secretary, Committee on Atomic Energy, Research and Development Board, Rm 3E1075, Pentagon, Washington 25, D. C.	221-222
Executive Secretary, Military Liaison Committee, PO Box 1814, Washington 25, D. C.	223
Commandant, Armed Forces Staff College, Norfolk 11, Va. ATTN: Secretary	224
Commanding General, Field Command, AFSWP, PO Box 5100, Albuquerque, N. Mex.	225-230
Chief, AFSWP, PO Box 2610, Washington 13, D. C.	231-239
University of California Radiation Laboratory, PO Box 808, Livermore, Calif. ATTN: Margaret Folden	240
Division of Military Application, U. S. Atomic Energy Commission, 1901 Constitution Ave., Washington 25, D. C.	241-243
Los Alamos Scientific Laboratory, Report Library, PO Box 1663, Los Alamos, N. Mex. ATTN: Helen Redman	244-246
Sandia Corporation, Classified Document Division, Sandia Base, Albuquerque, N. Mex. ATTN: Wynne K. Cox	247-266
Weapon Test Reports Group, TIS	267
Surplus in TISOR for AFSWP	268-316
Surplus in TISOR for DMA	317-366

UNCLASSIFIED
AEC, Oak Ridge, Tenn., A31951