

14

NSWC TR-79-153

LEVEL II

11
B.S.

AD A 077642

6 **INFLUENCE OF ROUGHNESS AND BLOWING ON COMPRESSIBLE TURBULENT BOUNDARY LAYER FLOW**

10 BY ROBERT L. P. VOISINET

9 Final report

STRATEGIC SYSTEMS DEPARTMENT

11 30 JUNE 1979

12 221

DDC
RECEIVED
DEC 5 1979
E

Approved for public release, distribution unlimited.

16 B0003

17 B0003

DDC FILE COPY



NAVAL SURFACE WEAPONS CENTER

Dahlgren, Virginia 22448 • Silver Spring, Maryland 20910

391596

79 22 5 011

B

UNCLASSIFIED

SECURITY CLASSIFICATION OF THIS PAGE (When Data Entered)

20. (Cont'd)

was measured directly using a skin-friction balance which had a provision for active blowing through the floating drag element. Data comparisons with skin-friction theories and law-of-the-wall velocity profile correlations are presented.

Accession For	
NTIS GRA&I	<input checked="" type="checkbox"/>
DDC TAB	<input type="checkbox"/>
Unannounced	<input type="checkbox"/>
Justification	
By _____	
Distribution/	
Availability	
Dist	Avail and/or special
A	

UNCLASSIFIED

SECURITY CLASSIFICATION OF THIS PAGE (When Data Entered)

SUMMARY

This report documents the results of an extensive experimental investigation which was conducted in the NSWC Aerodynamics facilities.

The determination of the relative and combined effects of surface roughness and mass transfer on turbulent boundary-layer development, and in particular, on skin-friction drag was the prime objective of this study. Wind tunnel tests were conducted in the NSWC Boundary-Layer Channel at a freestream Mach number of 2.9. The thick nozzle-wall boundary layer in the facility was subjected to a systematic variation of surface roughness and mass transfer conditions. Boundary-layer pressure and temperature surveys were obtained and skin friction was measured directly using a skin-friction balance which had a provision for active blowing through the floating drag element. Data comparisons with skin-friction theories and law-of-the-wall velocity profile correlations are presented.

Acknowledgement is given to the following individuals for their dedicated work on the task: Mr. T. J. Young, for the design of the mechanical test apparatus including the active blowing skin-friction balance; Mr. R. J. Marshall, for the efficient operation of the NSWC Boundary-Layer Channel Facility; and to Mr. F. C. Kemerer, who was responsible for the installation and alignment of the sensitive test equipment, models, and instrumentation.

In addition, the technical support and consultation given by Drs. W. J. Yanta, R. E. Lee, and D. C. Reda and the Program management provided by Dr. A. M. Morrison were greatly appreciated.

The author wishes to thank all individuals involved for their dedicated and enthusiastic participation in the test program.

DAVID R. BROWN, JR.
By direction

CONTENTS

	<u>Page</u>
SUMMARY.....	1
NOMENCLATURE.....	6
CHAPTER I INTRODUCTION.....	9
CHAPTER II EXPERIMENTAL APPARATUS AND TECHNIQUES.....	11
Wind Tunnel Facility and Test Apparatus.....	11
Porous Roughened Test Samples.....	12
Skin Friction Balance.....	13
Boundary Layer Instrumentation.....	17
Testing Matrix.....	18
CHAPTER III ANALYSIS AND RESULTS.....	19
Skin Friction Data.....	19
Effects of Surface Roughness on Skin Friction.....	20
Effects of Mass Transfer on Skin Friction.....	22
Combined Roughness and Blowing Effects on Skin Friction....	24
Velocity and Temperature Profile Data.....	25
Law-of-the-Wall Analysis.....	26
The Law-of-the-Wall with Roughness and Blowing.....	28
CHAPTER IV CONCLUSIONS.....	33
REFERENCES.....	35
APPENDIX A DATA TABULATION.....	77
Discussion of Tabular Data.....	77
Nozzle Flow.....	77
Data Interpolation.....	78
Computer Nomenclature.....	80

ILLUSTRATIONS

<u>Figure</u>		<u>Page</u>
1	NSWC Boundary Layer Channel.....	40
2	Test Plate Setup and Apparatus.....	41
3	Test Panel Cross Section.....	42
4a	Test Panel Cross Sections, Photographs.....	43
4b	Test Panel Planform Views, Photographs.....	44
5	Skin Friction Balance, Photograph.....	45
6a	Skin-Friction Balance Schematic, Mechanical Components.....	46
6b	Skin-Friction Balance Schematic, Gas Injection Components.....	47
7	Drag Element Force Balance.....	48
8	Drag Element Linkage-Bellows Alignment.....	49
9	Skin-Friction Balance Load Calibrations.....	50
10a	Load Calibration with Bellows Pressurization.....	51
10b	Load Calibration Shift with Bellows Pressurization.....	52
11	Roughness Testing Matrix.....	53
12	Blowing Testing Matrix.....	54
13	Smooth-Wall, Non-Blowing Skin Friction Data.....	55
14	Skin-Friction Data with Blowing, $K = 0.1$ mm.....	56
15	Skin-Friction Data with Blowing, $K = 0.33$ mm.....	57
16	Skin-Friction Data with Blowing, $K = 1.25$ mm.....	58
17	Skin-Friction Data with Blowing, $K = 0.1$ mm.....	59
18	Skin-Friction Data with Blowing, $K = 0.33$ mm.....	60
19	Skin-Friction Data with Blowing, $K = 1.25$ mm.....	61
20	Roughness Effects on Skin Friction.....	62
21	Roughness Effects on Skin Friction, a Comparison with Theory.....	63
22	Blowing Effects on Skin Friction.....	64
23	Blowing Effects on Skin Friction, a Comparison with Other Data.....	65
24	Blowing Effects on Skin Friction, a Comparison with Theory.....	66
25	A Comparison of Predicted and Measured Skin Friction Using Independent Correlation Schemes.....	67
26	Velocity Profiles with Roughness and Blowing.....	68
27	Temperature-Velocity Correlation Plots with Roughness and Blowing.....	69
28	Smooth-Wall, Non-Blowing Law-of-the-Wall Velocity Plots.....	70
29	Smooth-Wall, Non Blowing Law-of-the-Wall Profile Constants....	71
30	Typical Law-of-the-Wall Plot with Roughness.....	72
31	Law-of-the-Wall Velocity Plots with Roughness.....	73
32	Law-of-the-Wall Velocity Plots with Blowing.....	74
33	Shift in the Law-of-the-Wall Constant with Roughness.....	75

ILLUSTRATIONS (Cont'd)

<u>Figure</u>		<u>Page</u>
34	Shift in the Law-of-the-Wall Constant with Blowing.....	76
A-1	Nozzle Mach Number Distribution.....	82
A-2	Boundary-Layer Momentum Thickness Interpolation Relationship.....	83
A-3a	Boundary Layer Momentum Thickness Interpolation, $K = 0$	84
A-3b	Boundary Layer Momentum Thickness Interpolation, $K = 0.1$ cm.....	84
A-3c	Boundary Layer Momentum Thickness Interpolation, $K = 0.33$ cm.....	85
A-3d	Boundary Layer Momentum Thickness Interpolation, $K = 1.25$ cm.....	85

TABLES

<u>Table</u>		<u>Page</u>
1	Porous Roughened Test Samples.....	39
A-1	Boundary-Layer Profile Test Runs.....	86
A-2	Skin-Friction Test Runs.....	87
A-3	Boundary-Layer Profile Data Listing.....	88
A-4	Skin-Friction Data Listing.....	176

NOMENCLATURE

A, B	Constants in eqn. 13
C	law-of-the-wall constant in eqn. 12
$\Delta C_B, \Delta C_R$	shift in C due to blowing, roughness
C_f	skin-friction coef. = $2\tau_w/(\rho_\infty U_\infty^2)$
C_{fo}	smooth-wall, non-blowing skin friction coefficient
dw	roughness screen wire diameter
K	roughness screen thickness
K_s	equivalent sand-grain roughness height
M	Mach number
\dot{m}	blowing rate per unit area
P	pressure
P_o	stagnation pressure
r	recovery factor = $(T_{aw} - T_\infty)/(T_{o\infty} - T_\infty)$
Re/ft, Re/M unit	Reynolds number per foot, per meter, $\rho_\infty U_\infty/\mu_\infty$
Re_x	length Reynolds Number, $\rho_\infty U_\infty X/\mu_\infty$
Re_θ	momentum thickness Reynolds number, $\rho_\infty U_\infty \theta/\mu_\infty$
Re_K	roughness Reynolds number, KU_τ/v_w
Re_{Ko}	smooth-wall, non-blowing roughness Reynolds number, $K U_{To}/v_w$
S	roughness wire-mesh spacing
T	temperature

T_o	stagnation temperature
\bar{T}	$= (T_o - T_w)/(T_{o\infty} - T_w)$
U	velocity in X direction
\bar{U}	U/U_∞
U_τ	friction velocity, τ_w/ρ_w
U^*	transformed velocity (eqns. 12 and 17)
U^+	law-of-the-wall coordinate, U^*/U_τ
V	velocity in Y direction
X	distance along test plate from nozzle throat
Y	distance normal to test plate
Y^+	law-of-the-wall coordinate (eqn. 10)
γ	ratio of specific heats
δ	boundary-layer thickness
δ_{SUB}	boundary-layer smooth-wall sublayer thickness
δ^*	boundary-layer displacement thickness
θ	boundary-layer momentum thickness
κ	Karman constant (eqn. 12)
λ	blowing parameter, $2\dot{m}/(\rho_\infty U_\infty C_f)$
λ_o	blowing parameter, $2\dot{m}/(\rho_\infty U_\infty C_{fo})$
μ	viscosity
ν	kinematic viscosity
Π	wake constant
ρ	density
τ	shear stress

Subscripts

aw	adiabatic-wall
B	blowing
o	smooth-wall, non-blowing condition
R	roughness
w	at wall or based on wall properties
∞	boundary-layer edge conditions

I. INTRODUCTION

The development of advanced high-speed missiles and re-entry vehicles has prompted continued research in aerothermodynamics with an increased emphasis on accuracy in the prediction of the aerodynamic performance of future vehicles. In application to re-entry nosetip, heatshield, and rocket nozzle technology, the effects of surface ablation have received considerable attention. This paper deals with two phenomena which are interrelated through the ablation process, namely surface roughness and mass transfer.

Inherent to the ablation process is surface erosion and the accompanying development of surface roughness. In addition, the decomposition of surface materials results in a sublimation and outgassing from the surface. Generally, the effects of surface roughness are to cause an augmentation of heat-transfer and skin-friction rates over the aerodynamic surface whereas blowing causes a reduction. In the ablation process, however, these two phenomena interact and their combined effects on skin friction and heat transfer are unknown. It is for this reason that a detailed experimental program was conducted wherein direct measurements of skin-friction drag and boundary-layer velocity and temperature profiles were obtained in the presence of roughness, blowing, and combined roughness and blowing.

II. EXPERIMENTAL APPARATUS AND TECHNIQUES

WIND TUNNEL FACILITY AND TEST APPARATUS

Wind-tunnel tests were conducted in the Naval Surface Weapons Center (NSWC) Boundary Layer Channel.¹ The facility, shown schematically in Fig. 1, consists of a supersonic half nozzle which has for one wall a 2.5-meter long flat test surface on which boundary-layer measurements are made. The opposite wall is flexible and was adjusted in these tests to provide a zero-pressure-gradient flow in the test section. The facility has been used for many turbulent boundary-layer studies in the past and its capabilities are well documented.¹⁻⁶

In order to adapt the facility to the requirements of the present study the lower portion of the flat test plate was designed to accommodate interchangeable porous roughened test plate inserts. Each insert allowed for the conditioning of the nozzle wall boundary-layer flow to a different roughness and blowing test requirement.

The test plate apparatus is shown schematically in Fig. 2. All of the test plate inserts were the same size extending one meter in length and 0.3-meters in width. When installed, each was mounted flush with the surrounding nozzle wall

1. Lee, R. E., et al., "The NOL Boundary Layer Channel," NOLTR 66-185, Nov. 1966.
2. Voisinet, R. L. P. and Lee, R. E., "Measurements of a Mach 4.9 Zero-Pressure-Gradient Turbulent Boundary Layer with Heat Transfer - Part 1, Data Compilation," NOLTR 72-232, Sep 1972.
3. Voisinet, R. L. P. and Lee, R. E., "Measurements of a Supersonic Favorable-Pressure-Gradient Turbulent Boundary Layer with Heat Transfer - Part 1, Data Compilation," NOLTR 73-223, Dec 1973.
4. Voisinet, R. L. P., Lee, R. E. and Yanta, W. J., "An Experimental Study of the Compressible Turbulent Boundary Layer with an Adverse Pressure Gradient," Paper No. 9, Turbulent Shear Flows, AGARD CP-93-71, Sep 1971.
5. Voisinet, R. L. P., "An Experimental Investigation of the Compressible Turbulent Boundary-layer Separation Induced by a Continuous Flow Compression," Paper No. 19, Flow Separation, AGARD CP-168, May 1975.
6. Reda, D. C., "Compressible Turbulent Skin Friction on Rough and Rough/Wavy Walls in Adiabatic Flow," NOLTR 74-34, Feb 1974. Also AIAA Journal Vol. 13, No. 5, May 1975, pp. 553-554.

and spanned the full width of the test section. The beginning of the insert was located at the 1.22 meter station. Since a floating element skin-friction balance was utilized in the tests to obtain direct measurements of surface shear stress over the test plates, a 12.7 X 25.4 cm. rectangular section was cut from each insert to accommodate the skin-friction balance drag element. This cutout was centrally located at the 1.88 meter station. For this test arrangement the complete test plate assembly was located within the constant pressure region of the nozzle and the skin friction measuring location was a nominal 25 boundary-thicknesses downstream of the beginning of the roughness and blowing. Air leakage through the balance from the wind-tunnel plenum chamber to the test section was eliminated by sealing the balance back housing.

Flow chambers existed behind the test plate insert and allowed for active gas injection through the porous wall and into the boundary layer. Two large flow distribution chambers were located ahead of the drag element and three smaller ones surrounded it. Injectant air flow to each chamber was regulated independently by controlling the pressure ahead of calibrated sonic orifices which were located at each of the chamber inlets. By using sonic orifices for control, the regulation of mass flow rate was made independent of changes in the wind tunnel static pressure. As the injectant air entered each chamber it was dispersed laterally and baffled through a perforated plate before reaching the porous test plate inserts. The distribution of injectant air to the skin-friction balance drag element was accomplished in the same manner. As a result of this design the only discontinuities in blowing rate over the test plate occurred at the chamber bulkheads which were nominally 3-mm. in width.

In addition to the skin-friction balance which was used in the test apparatus, several instrumentation ports were located downstream of the test plate inserts and allowed for the installation of boundary-layer probes. These probes extended upstream to a position 2.54 cm ahead of the trailing edge of the drag element of the skin-friction balance and provided for boundary-layer pressure and temperature surveying over the test element. Test plates were also instrumented with static pressure taps and wall temperature thermocouples.

POROUS ROUGHENED TEST SAMPLES

Present test requirements called for flat test plate panels which had to meet both blowing and surface roughness specifications. The panels had to be uniform in porosity with a small pore size and spacing so as to eliminate jetting effects. In addition, the surface roughness height had to be different for each panel while the roughness type and pattern had to be the same. These requirements were satisfied by using test plates which were constructed of a multi-layer wire-mesh composite. Each panel was designed to have the same porosity characteristics while the surface roughness of each panel was varied by changing the surface screen mesh size.

Fig. 3 shows the multilayer construction of the composite. Each of the samples consists of a perforated metal sheet which gives the strength and rigidity to the composite, a 20-mesh inner screen which provides for flow distribution, and five layers of 50 X 250 Dutch weave which provide the appropriate material permeability. These composite layers were typical of all the panels and this provided for a uniformity in blowing characteristics. The test plate permeability was selected in such a manner as to provide sufficient pressure drop across the test

panels to improve injectant flow uniformity, but with limitations on the pressure drop to avoid panel deflection problems. Flow uniformity over the test samples was verified to be of the order of 5 percent.

The surface roughness of the panels was controlled by bonding an additional screen mesh to the surface of the multilayer composites. Three roughness meshes were utilized to provide the range of roughnesses necessary. Nominal values of mesh/wire diameter were: 200-mesh/0.0023, 60-mesh/0.0075, and 14 mesh 0.0028-inch. These meshes provided roughness heights of 0.1, 0.33, and 1.25-mm (0.004, 0.013, and 0.049-inches). In addition, the mesh spacing differences allowed for a scaling of the roughness pattern by maintaining a near constant value of the mesh spacing to wire diameter ratio. Dimensions for the test panels are given in Table 1. Photographs of the test panels are presented in Figs. 4a and 4b.

All panels were constructed of non-corrosive, non-oxidizing stainless steel materials which were diffusion bonded together. Oversized panels were fabricated and later machined to the required dimensions. The sample which was used for the skin-friction balance drag element was cut from the same sheet of material as its accompanying test plate insert. The orientation of the square weave surface roughness mesh was the same for all panels with the mesh wires aligned at a 45-degree angle to the streamwise direction.

SKIN FRICTION BALANCE

GENERAL DESCRIPTION. Direct measurements of skin friction were obtained with a specially designed skin-friction balance which had a provision for active blowing through the drag element. This instrument has been reported in references 7 and 8 and is pictured in Figure 5. The balance concept is based on previous NSWC experience in skin-friction balance design.^{6, 9-12} Many of the balance components are conventional in nature; however, the test requirement for active blowing through the drag element makes this skin-friction balance unique.

7. Voisinet, R. L. P. and Young, T. J., "A Skin-Friction Balance for Roughness and Blowing Studies," AIAA Paper 78-780, 10th Aerodynamic Testing Conference, April 1978.
8. Voisinet, R. L. P., "Combined Influence of Roughness and Mass Transfer on Turbulent Skin Friction at Mach 2.9, AIAA Paper 79-0003, 17th Aerospace Sciences Meeting, Jan 1979.
9. Bruno, J. R., et. al., "Balance for Measuring Skin Friction in the Presence of Heat Transfer", NOLTR 69-56, Jun 1969.
10. Chien, K., "Hypersonic Turbulent Cold-Wall Skin-Friction and Heat-Transfer Measurements on an Axisymmetric Sharp Cone", NOLTR 73-108, Jun 1973.
11. Horanoff, E. V. and Driftmyer, R. T., "Two-Component Force Balance for Measuring Skin Friction and Side Force", NSWC/WOL/TR 75-174, Oct 1975.
12. Voisinet, R. L. P., "Temperature Step Effects on Direct Measurement of Skin-Friction Drag", NSWC/WOL/TR 77-7, 1977.

The balance is shown schematically in Figures 6a and 6b. The mechanical components are shown in the first schematic and the mass-addition components are shown in the second. The balance is a positive displacement type which requires the measurement of the drag-element deflection under the action of a drag force. The drag element is supported by four linkages and frictionless flexural pivots which allow movement of the drag element in the streamwise direction. Leafsprings provide restraining forces which are proportional to the deflection of the drag element. By using leafsprings with different stiffnesses, the balance could accommodate a wide range of drag loading from 50 to 1000 mg. full scale. This feature was particularly important because of the wide variation in loading expected with variations in Reynolds number, roughness and blowing. Drag-element deflections were kept small (less than the 0.25 mm gap dimension around the drag element) and were measured using a highly sensitive translational Linear Variable Differential Transformer (LVDT). The balance load calibration was performed simply by hanging calibrated weights on the drag element and determining the deflection of the drag element using the LVDT.

Active blowing through the drag-element was accomplished by piping the injectant gas to the drag-element in such a way as to minimize the effects of the blowing on the balance operation and calibration. Injectant air entered the balance from two ports at the back of the housing. The injectant air then passed through flexible metallic bellows to the drag-element for flow distribution. The key to the design of the active blowing system was the alignment of the primary metallic bellows with the drag-element support linkages (see Figure 7).

As the bellows become pressurized, the expansion forces which act along the axis of the bellows are restrained by the linkages. Because these forces act in a direction normal to the test surface, there is no component of the bellows expansion forces acting in the direction of the friction drag and thus no interaction between the blowing and the load calibration. In actuality, the drag element deflects slightly from its null position when loaded (as illustrated in Figure 8) and a slight restoring moment has to be accounted for. These effects were easily calibrated, and the error was never greater than 3 percent of the most sensitive (50 MG) load range. At the higher load ranges, this error became negligible and the balance calibration was essentially independent of blowing as will be shown.

DRAG ELEMENT. The balance drag element was chosen to be rectangular in shape and of relatively large size (12.7 x 25.4 centimeters) in contrast to previous NSWC designs which had small circular elements. The larger size was specified to reduce drag-element edge-gap effects. These effects are primarily due to drag-element misalignment; however, they may result from non-uniform gap pressures acting around the drag-element perimeter. The relative magnitude of the edge-gap force to the skin-friction force varies in proportion to the ratio of the drag-element perimeter to surface area. Since this ratio decreases for increasing drag-element size, the larger the size, the lower the edge-gap effects. As an added precaution, the edge gap was kept small (less than 0.25mm) and the edge of the drag element was beveled as a pressure relief mechanism to provide a more uniform edge pressure around the drag element. The larger size of the drag element also provided for a sturdier instrument, a more simplified fabrication of some mechanical components, and a skin-friction measurement which was averaged over a larger surface area. The large surface area also insured sufficient repetition of the roughness pattern over the drag element.

LEAFSPRINGS. The restoring force which countered the drag force was provided by leafsprings which were mounted on the drag element in opposing pairs. The springs were cantilever beams which provided a force proportional to their displacement. Two pairs of leafsprings were employed on the drag element. One was a light-duty and the other a heavy-duty spring. By using various combinations of leafsprings, the balance could accommodate a wide range of loading. Leafspring adjustment screws were provided on each spring for use in null alignment of the balance drag element. These screws could also be retracted to disengage a leafspring from operation.

FLEXURAL PIVOTS. The flexural pivots are frictionless bearings which were used in the drag-element support linkages. They were made of pairs of flat, crossed springs which support rotating sleeves. The flexures are suitable for small angular deflections, have no backlash and require no lubrication. The flexural pivots are commercially available in a range of size and torsional spring rates.

THE LVDT. The Linear Variable Differential Transformer (LVDT) was used to measure the displacement of the drag element under loading. It is an electro-mechanical transducer that produces an electrical output in proportion to the displacement of a moveable inner core. In its simplest form three coils are equally spaced on a cylindrical coil form. A rod-shaped magnetic core is positioned axially inside the coil assembly and provides a path for magnetic flux linking the coils. When the primary, or center coil, is energized with alternating current, voltages are induced in the two outer coils. The outer, or secondary coils, are connected in series opposition. The two voltages in the secondary circuit, therefore, are opposite in phase. The net output of the transformer is the difference between these voltages. When the core is in the center position, the output is zero. This is referred to as the null position. When the core is moved from the null position, the voltage induced in the coil toward which the core is moved increases, while the voltage induced in the opposite coil decreases. This produces a differential voltage output which varies linearly with changes in core position. Since the output of the LVDT is stepless, its resolution is limited only by the ability of the electronics to detect a change in output. In the present application a Schaevitz Co. type 010MHR LVDT was used. The full-scale linear range of the LVDT was ± 0.254 mm with a 0.25 percent (of full-scale) linearity. Since the core of the LVDT does not make contact with the coil assembly, the LVDT provided for a frictionless displacement transducer of a very high accuracy and resolution.

COUNTERWEIGHT. A drag-element counterweight was employed in the design to increase balance sensitivity and reduce wind tunnel vibration effects. Structural vibrations can be transmitted to the drag element only via the center flexural pivot in each linkage. Because this pivot point is also the center of gravity (c.g.) of the drag-element/counterweight system, torques cannot develop from vibrations of this point and the load calibration is unaffected. The sensitivity of the balance was also improved by the counterweight. If the counterweight were not used, the drag element would have to be supported by extremely heavy leafsprings or support webs to counter its heavy weight. Since these support webs determine the load sensitivity of the balance, the balance sensitivity would be coarse and invariable. The counterweight relieved the drag-element weight restraints on the leafsprings and alleviated the problem. The counterweight was a particular necessity in this design because of the vertical orientation of the

balance in the wind tunnel. This would not be a necessary requirement in a horizontal orientation except for the elimination of structural vibrations effects.

MAGNETIC-FLUID DAMPER. A magnetic-fluid dashpot was introduced in the system to damp out drag-element oscillations caused by residual vibration effects and/or flow unsteadiness. The dashpot was composed of a small piston housed in a non-ferrous cylindrical casing with a clearance gap between the two. The piston was made from a magnet and a Ferromagnetic damping fluid,^{13, 14} was introduced into the clearance gap. The damping fluid (Dyester base, 10K centipoise viscosity) stayed in the gap because of its magnetic attraction to the piston. The size of the piston and gap and the viscosity of the damping fluid determined the amount of viscous damping which was introduced.

TEMPERATURE SENSITIVITY. Although the temperature environment of the balance was not severe in the present tests, precautions were taken to minimize any effects which might result from ambient temperature changes. Invar and other materials with low coefficients of thermal expansion were used for all critical balance components and supporting framework.

INJECTANT GAS FLOW DISTRIBUTION. The uniformity of the blowing over the porous test sample is dependent to a certain degree on the distribution of the gas flow behind the test sample. The gas-flow rate to the balance was regulated and equally distributed to two inlet ports at the back of the balance. The gas was piped from the back frame to the drag element via thin-walled flexible bellows. The inside diameter of the bellows was large enough to handle the gas-flow rate and the wall thickness thin enough to allow flexibility and movement of the drag element. As the gas emerged from the bellows it impinged on a flow deflector which dispersed the jet-like stream to the flow-distribution chamber. The flow was further disbursed in passing through a perforated plate before reaching the porous test sample. A similar procedure was used to distribute the injectant gas in the test plate surrounding the drag element. The balance and test plate were designed to accommodate mass injection rates as high as $0.15 \text{ kg/m}^2\text{sec}$.

ASSEMBLY AND CALIBRATION. The successful operation of the skin-friction balance was dependent on the integration of a number of different components. For this reason, special precautions had to be taken in the assembly of the balance. The balance counterweight had to be adjusted to the total weight of the drag element and its attached components prior to assembly. The flexural pivots had to be installed without residual torsional stress. The bellows had to be aligned with the support linkages. Seals had to be leakproof. Adjustment screws and linkages had to be tight fitting. In addition, the alignment of components had to be made in a specific manner.

13. Ezekiel, F. D., "Uses of Magnetic Fluids in Bearings, Lubrication, and Damping", ASME Paper 75-DE-5, 1975.

14. Moskowitz, R., "Designing with Ferro-magnetic Fluids", ASME Paper 74-DE-5, 1974 and reprinted in Mechanical Engineering, Feb 1975.

All critical balance components were adjusted in reference to a primary balance frame. This primary frame and associated balance components were then moved as a unit to provide the necessary alignment of the drag element with the surrounding tunnel wall upon installation in the wind tunnel. By performing the adjustment in this manner, the alignment of internal balance components was not changed, and the balance load calibration was unaffected.

The balance alignment began by determining the balance null position. This position is defined as the point where the drag element does not deflect when the bellows are pressurized. It establishes the point of non-interference between the active blowing and no-load calibration point. The leafsprings were then adjusted to hold this null position and the LVDT core was centered in this position.

The balance load calibration was performed simply by attaching weights to the drag element and measuring the deflection of the drag element from its null position with the LVDT. A straight line calibration between displacement and loading was typical, as shown in Figure 9 for the different leafspring configurations. With active blowing the calibrations changed slightly because the drag element was deflected from its null position and a component of the bellows expansive force was felt on the drag element in the direction of the load measurement. Calibrations could still be represented by straight lines because the induced loading increased linearly with the displacement of the drag element from its null position. This effect can be seen in Figures 10a and 10b. The calibration shift was found to be a linear function of the displacement from the null position and the pressure in the bellows. Figure 10b further indicates that there was no difference between calibrations obtained under static pressurized test conditions and those with mass transfer through the balance (no leafsprings installed, 50 grams maximum load). This effect was calibrated and corrections were made in the data reduction. At the higher load ranges this effect was negligible and the skin-friction balance calibration was essentially independent of blowing.

BOUNDARY-LAYER INSTRUMENTATION

Boundary-layer profile surveys were made in a manner similar to previous investigations²⁻⁶ using a Pitot pressure probe and a Fine-Wire Stagnation Temperature Probe.¹⁵ The data from these probes, combined with the wall pressure and temperature, were sufficient to describe the Mach number, total and static temperature, and velocity boundary-layer profiles.

Pitot-pressure profiles were obtained using a flattened Pitot probe with a rectangular 0.076 x 2.54 - mm. inlet. Pitot corrections which have been applied in the past² to accommodate for slip flow and probe-wall interference effects were not used in these tests due to the complexity of the flow near the wall with roughness and blowing.

The probe used to measure stagnation temperature consisted of a fine wire (0.0254 mm. dia., 3.56-mm. long) supported normal to the flow with a chromel-alumel thermocouple junction at its center. The local stagnation temperature

15. Yanta, W. J., "A Fine-Wire Stagnation Temperature Probe," NOLTR 70-81, Jun 1970.

was computed from the measured temperature at the wire center and support and the corresponding Mach number using the empirical equations given in Reference 15 for predicting the heat exchange to and from the wire. The local static temperature was evaluated from the local stagnation temperature and Mach number.

Pressure and temperature probes were normally traversed simultaneously in a double probe holder. However, at higher Reynolds number conditions, the temperature probe could not survive the high dynamic loading and only a single Pitot probe was traversed. For these runs, the temperature was derived from a modified Crocco relationship with the velocity.

TESTING MATRIX

Wind-tunnel tests were conducted at a freestream Mach number of 2.95 and Reynolds number per meter from 1.0 to 30. million. Stagnation pressures ranged from 0.1 to 4. atmospheres at a nominal stagnation temperature of 318°K. The wall temperature was not controlled but remained at a near constant 295°K since heat transfer conditions were nominally adiabatic over the test surface.

A total of four test plate inserts were tested. A smooth impervious surface was run first to establish the smooth-wall non-blowing baseline data. Testing of the three porous, roughened surfaces followed. The three surface screen roughnesses of 0.1, 0.33, and 1.25 mm (0.004, 0.013, and 0.049-inches) provided for a range of surface roughness conditions from the aerodynamically smooth through the fully rough regime as depicted in Figure 11. The ratio of the roughness height to the smooth-wall boundary-layer sublayer thickness is plotted as an indicator of the roughness regime. For ratios less than 0.5 the roughness elements are submerged in the laminar sublayer and have no effect on the skin friction. The surface is considered aerodynamically smooth. For higher ratios, the roughness affects skin friction and this effect is classified into one of two roughness regimes. It should be noted that although the roughness height is constant for each test plate, the roughness regime varies with Reynolds number due to the variation in the boundary-layer sublayer thickness.

Each of the porous roughened test plates was tested at three mass transfer rates. These were 0.0146, 0.0488, and 0.146 kg/m²-sec (0.003, 0.01, and 0.03 lbs/ft²-sec). These rates provided a range of mass transfer up to and including boundary-layer blowoff as illustrated in Figure 12. Again, it should be noted that although the blowing rate was constant, the blowing ratio $\dot{m}/\rho_{\infty}U_{\infty}$ varied with Reynolds number due to the variation in the freestream density. As such, both the roughness and blowing regimes varied over the Reynolds number range even though the roughness height and blowing rate were constant.

Skin-friction and boundary-layer profile measurements were made over the full range of the testing matrix. Reynolds number was varied by adjusting the wind-tunnel supply pressure. For each roughness and blowing test condition, skin friction was monitored continuously over the Reynolds number range while boundary-layer surveys were obtained at discrete Reynolds number conditions corresponding to nominal tunnel supply pressures of 0.5, 1., 2., and 4. atmospheres. Profile surveys were obtained at one streamwise location corresponding to X = 1.98 meters. The skin friction was assumed to act at the center of the floating drag element corresponding to the location X = 1.88 meters. The differences in measurement location were accounted for in combining skin-friction and boundary-layer profile parameters.

III. ANALYSIS AND RESULTS

SKIN-FRICTION DATA

Before discussing the roughness and blowing results, the reference smooth-wall, non-blowing skin-friction data should be noted. These data are shown in Figure 13 as a function of the momentum thickness Reynolds number. The data were obtained from several test runs with different balance sensitivities and a re-installation and alignment of the balance for each test. The small scatter in the data illustrates the repeatability and self-consistency of the results. A comparison of the data with theory indicates that the experimental values are lower than those predicted by Spalding-Chi¹⁶ by approximately 15 percent. The fact that the skin-friction coefficient varies inversely with the momentum thickness Reynolds number to the 0.2 power is consistent with established theory for flow over smooth, impervious surfaces.

Figures 14 through 19 show the skin-friction results with roughness and blowing. The data are presented in two ways. In Figures 14-16 the skin friction is plotted against a momentum thickness Reynolds number which is based on smooth wall, non-blowing values of the boundary-layer momentum thickness. These graphs are equivalent to plotting data for equivalent length Reynolds number (Re_x) conditions because the boundary-layer integral thicknesses do not reflect the changes which occur due to the roughness and blowing. Figures 17-19 show the data in terms of actual values of the momentum thickness Reynolds number where the momentum thickness is evaluated from the measured boundary-layer profile surveys. The two sets of plots are presented because roughness and blowing effects can be correlated either in terms of the effects at a particular location (Re_x) or at a particular local state of the boundary layer (Re_θ). The latter should be used because it has more generality and can be applied to flows having different roughness run lengths and cases involving non-constant freestream velocity. It is not always the easiest to apply, however.

Each plot represents the data for a single roughness test plate, with and without blowing. A solid line is plotted in each figure which represents the reference smooth-wall, non-blowing data which was presented in Figure 13. The other solid lines plotted through the data represent a data fairing for a single roughness and blowing condition. Because the roughness and blowing effects on skin friction were so drastic, resulting in a two order of magnitude change

-
16. Spalding, D. B., and Chi S. W., "The Drag of a Compressible Turbulent Boundary Layer on a Smooth Flat Plate with and without Heat Transfer," J. Fluid Mechanics, Vol. 18, Part I, Jan. 1964, pp. 117-143.

in skin friction in some cases, the measurements for a single test condition often had to be obtained from multiple wind-tunnel runs using different drag-balance sensitivities. The self-consistency in these results was encouraging.

The data shown in Figures 14 and 17 are for the smoothest of the porous test plates. Without blowing, the results agree exactly with the smooth-wall, non-blowing baseline data at the lower Reynolds numbers. For these conditions the roughness elements are submerged in the boundary-layer laminar sublayer and the surface is considered aerodynamically smooth, exhibiting no roughness effects. As the Reynolds number is increased, the viscous sublayer thins, and the roughness falls into the transitionally rough regime. This effect is consistent with roughness regimes which were specified in Figure 11. (The agreement in skin-friction results between this "smooth" porous test plate and the smooth solid test plate used to establish the baseline results is a further demonstration of the experimental self-consistency.) With roughness, the skin-friction coefficient rises above the smooth wall level. With blowing the effect is reversed and a marked reduction in skin friction is noted. This reduction is proportional to the blowing rate and a function of the Reynolds number as discussed previously in regards to Figure 12. Although the blowing rate, \dot{m} , is constant, the blowing ratio, $\dot{m}/\rho_\infty U_\infty$, varies with Reynolds number. As such, the blowing effect is always greater at the lower Reynolds numbers for constant \dot{m} . The trends in the data for higher roughness are very similar to those just discussed, with the main differences relating to the roughness regime. In Figures 16 and 19 the skin-friction data show fully rough tendencies with the non-blowing skin-friction data becoming independent of Reynolds number.

EFFECTS OF SURFACE ROUGHNESS ON SKIN FRICTION

In analyzing the effects of surface roughness, the ratio of the roughness height to laminar sublayer thickness has been introduced as the characterizing factor. For roughness heights much less than the sublayer thickness, the surface is effectively smooth, exhibiting no drag increasing effect. On the other hand, if the roughness is so large as to disrupt the laminar sublayer completely, then the surface resistance will be independent of viscosity. This is the fully rough regime. Between the two regimes is the intermediate region. In order to quantify these regimes, a roughness Reynolds number parameter is commonly introduced which is proportional to the roughness height-sublayer thickness ratio. This roughness Reynolds number, Re_K , is defined in terms of a shear velocity, U_τ , as

$$Re_K = \frac{K U_\tau}{\nu_w} \quad (1)$$

and

$$U_\tau = \sqrt{\tau_w/\rho_w} \quad (2)$$

Nikuradse¹⁷, for example, used this approach in analyzing data from pipe flows with roughness. Extensions of those early results to boundary-layer flows including compressibility have been established by numerous investigators.^{6,18-22} Using the roughness Reynolds number, the roughness effects can be classified as follows:

$$\begin{array}{ll} \text{Re}_K < 5 & \text{aerodynamically smooth} \\ 5 < \text{Re}_K < 70 & \text{transitionally rough} \\ 70 < \text{Re}_K & \text{fully rough} \end{array} \quad (3)$$

The roughness Reynolds number approach was applied to the present data for the rough, non-blowing test conditions as shown in Figure 20. The data are plotted in rough-to-smooth skin-friction ratio form for equivalent Re_X . The data for the three roughnesses are seen to collapse to a single curve when correlated in this way. This result substantiates the claim that the roughness Reynolds number is the primary parameter for the analysis of geometrically similar roughnesses. The agreement further supports the proposal of roughness similarly for screens based on the ratio of the mesh spacing to roughness height.

A comparison of the roughness data with the theories of Fenter¹⁹ and Goddard²⁰ are shown in Figure 21. In this plot the ratio of the rough-to-smooth skin friction is presented both for equivalent Re_X and Re_θ . The theories of Goddard and Fenter have both been shown to agree with other data over a wide range of Mach number and roughness conditions. They do not differ significantly in this comparison with the exception of the data in the transitionally rough regime. The present data follows the trend of the Fenter theory more closely in this region whereas the Goddard correlation makes no deviation from the fully rough straight line trend. The present data appears to be shifted slightly from the theories. This tendency can be explained in terms of the roughness

-
17. Nikuradse, J., "Laws of Flow in Rough Pipes," English translation, NACA TM No. 1292, Nov. 1950.
 18. Hama, F. R., "Boundary Layer Characteristics for Smooth and Rough Surfaces," Transactions Society Naval Architects Marine Engineers, Vol. 62, 1954, pp. 333-358.
 19. Fenter, F. W., "The Turbulent Boundary Layer on Uniformly Rough Surfaces at Supersonic Speeds," Vought Research Center, Rpt. No. RE-E9R-2, Dec 1959.
 20. Goddard, F. E., Jr. "Effect of Uniformly Distributed Roughness on Turbulent Skin-Friction Drag at Supersonic Speed," J. Aeronautical Sciences, Vol. 26, No. 1, pp. 1-15, Jan 1959.
 21. Young, F. L., "Experimental Investigation of the Effects of Surface Roughness on Compressible Turbulent Boundary Layer Skin Friction and Heat Transfer," Defense Research Laboratory Report DRL-532, May 1965.
 22. Berg, D. E., "Surface Roughness Effects on the Hypersonic Turbulent Boundary Layer," SAND77-0587, Sandia Laboratories, Albuquerque, New Mexico, Sep 1977.

equivalency. Screen roughness data are being compared to theories based on a sand grain roughness. As such, the results are not unexpected. This topic will be addressed in a later section.

EFFECTS OF MASS TRANSFER ON SKIN FRICTION

The effects of mass transfer on skin friction have been evaluated by many investigators in the past. The review paper by Jeromin²³ provides a particularly good summation of those results. The blowing parameter which has evolved as being primary in correlating skin-friction results is of the form

$$\lambda_o = \frac{\dot{m}}{\rho_\infty U_\infty} \frac{2}{C_{fo}} \quad (4)$$

In some cases, the implicit parameter, λ , is used. This parameter has the same form as λ_o but uses the actual rather than zero-injection value of the skin friction.

In this experiment some roughness was always present when blowing was introduced. However, for the smoothest of the porous test plates the roughness was shown to be aerodynamically smooth at the lower Reynolds number conditions. These data could therefore be used to evaluate the effects of blowing. These results are presented in Figure 22 in terms of the λ_o blowing parameter. The data for the three blowing rates are seen to collapse to a single curve when correlated this way, substantiating the use of the λ_o blowing parameter. Skin friction is reduced drastically with blowing and is seen to reach a blowoff condition at a λ_o value near 5.

A comparison of the blowing results with other blowing data are shown in Figure 23. The measurements of Kendall et al.,²⁴ Goodwin²⁵, and Simpson²⁶ are presented for subsonic flow conditions and the data of Dershin et al.²⁷ are presented for supersonic flow conditions which are almost identical to that of the present test. Dershin's data were also measured directly using a skin-friction balance as in the present experiment. (Skin-friction data with blowing

23. Jeromin, L. O. F., "The Status of Research in Turbulent Boundary Layers with Fluid Injection," Progress in Aeronautical Sciences, Vol. 10, pp. 65-189, 1970.
24. Kendall, R. M., Rubesin, M. W., Dahm, T. J., Mendenhall, M. R., "Mass, Momentum, and Heat Transfer Within a Turbulent Boundary Layer with Foreign Gas Mass Transfer at the Surface," Vidya Report No. 111, February 1964.
25. Goodwin, B. M., "The Transpired Turbulent Boundary Layer with Zero Pressure Gradient," MIT Doctor of Science Thesis, May 1961.
26. Simpson, R. L., Moffat, R. J. and Kays, W. M., "The Turbulent Boundary Layer on a Porous Plate: Experimental Skin Friction with Variable Injection and Suction," Int. J. Heat Mass Transfer, Vol. 12, pp. 771-789, 1969.
27. Dershin, H., Leonard, C. A., and Gallaher, W. H., "Direct Measurement of Skin Friction on a Porous Flat Plate with Mass Injection," AIAA Journal, Vol. 5, No. 11, 1967.

are few and those for which the skin friction was measured directly are almost non-existent.) The results from the data comparison are indeed encouraging. The λ_o blowing parameter collapses the data with no identifiable Mach number dependence. This latter implication is not a generally accepted fact. The skin friction results of Pappas and Okuno²⁸ and others for porous sharp cones exhibit a significant Mach number dependence causing a disparity with the present measurements and those of Dershin. Analysis by Baronti²⁹ suggests that for uniform injection, the relationships for flat plate and cone flows should be the same, nearly independent of Mach number, Reynolds number, and temperature ratio. The differences between flat plate and cone data are still unexplained but appear to be related to the techniques used to obtain the skin-friction measurements and to some degree on the geometry of the models tested. For this reason, only data obtained from flat plate configurations using direct measuring techniques was presented in Figure 23. As such, the statement made earlier pertaining to the minimal Mach number dependence in the correlation must be qualified.

A comparison of the skin friction data with theory is shown in Figure 24. The theory denoted as Couette flow was developed in the early 1950's by Crocco³⁰ and has consistently been shown to be a good fit to incompressible results.³¹ The relation is given by:

$$\left. \frac{C_f}{C_{fo}} \right|_{Re_x} = \frac{\lambda_o}{e^{\lambda_o - 1}} \quad (5)$$

Extensions of this theory to include compressibility were formulated by Rubesin³² and Dorrance and Dore.³³ Both of these theories show minimal effects of Mach number on the skin-friction reduction with blowing. Kutateladze and Leont'yev³⁴

-
28. Pappas, C. C., Okuno, A. F., "Measurement of Skin Friction of the Compressible Turbulent Boundary Layer on a Cone With Foreign Gas Injection," *Journal of the Aero/Space Sciences*, Volume 27, No. 5, May 1960.
 29. Baronti, F., Fox H., and Soll, D., "A Survey of Compressible Turbulent Boundary Layer with Mass Transfer," *Astronautica Acta*, Vol. 13, pp. 239-248, 1967.
 30. Crocco, L., "An Approximate Theory of Porous, Sweat, or Film Cooling with Reactive Fluids," *J. American Rocket Society*, Vol. 22, pp. 331-338, 1952.
 31. Kays, W. M. and Moffat, R. J., "The Behavior of Transpired Turbulent Boundary Layers," *Stanford University*, Report No. HMT-20, April 1975.
 32. Rubesin, M. W., "An Analytical Estimation of the Effect of Transpiration Cooling on the Heat-Transfer and Skin-Friction Characteristics of a Compressible Turbulent Boundary Layer," *NACA TN 3341*, December 1954.
 33. Dorrance, W. H., and Dore, F. J., "The Effect of Mass Transfer on the Compressible Turbulent Boundary-Layer Skin Friction and Heat Transfer," *J. Aeronautical Sciences*, June 1954.
 34. Kutateladze, S. S. and Leont'yev, A. I., Turbulent Boundary Layers in Compressible Gases, Academic Press, New York, 1964.

introduced the concept of a critical blow-away parameter, λ_{ocr} , defined as the limiting value of the blowing parameter at the point when the skin friction vanishes. The form of their relation is given by:

$$\frac{C_f}{C_{fo}} = \left(1 - \frac{\lambda_o}{\lambda_{ocr}}\right)^2 \quad (6)$$

with $\lambda_{ocr} = 4$ for incompressible flows. This relation has been modified to include compressibility effects,³⁵ but these results are not presented herein. Laganelli³⁶ and Foganoli³⁷ used the same form for the blowing correlations but adjusted the exponent and critical blow-away parameters to empirically match existing data. The large disagreement between the present data and the Laganelli relation reflects the influence of using cone flow data in the empirical fits. The large Mach number effect exhibited by cone data is in disagreement with the trends of this study. In the same way the completely empirical relation of Walker³⁸ reflects the same influence. It appears as though this Mach number discrepancy must be resolved before any further empirical correlations are developed.

COMBINED ROUGHNESS AND BLOWING EFFECTS ON SKIN FRICTION

Since there are no theories which presently exist for evaluating skin friction under the combined influence of roughness and blowing, an approach which is generally used for design purposes is to apply each correlation independently. This approach has been applied to the present data for comparative purposes, however, it should not be construed as a suggested approach to the solution of the problem.

Based on the roughness only and blowing only data previously discussed, a single correlation parameter was identified as being primary for each effect. These were the roughness Reynolds number, Re_K , and blowing parameter, λ . A curve fit of the roughness only and blowing only data was made in terms of each of the respective parameters and applied to the combined roughness and blowing data. The relationships were applied in the form:

$$\frac{C_f}{C_{fo}} \Big|_{R+B} = \frac{C_f}{C_{fo}} \Big|_R \frac{C_f}{C_{fo}} \Big|_B \quad (7)$$

35. Kutateladze, S. S., and Leont'yev, A. I., "Heat-Mass Transfer and Friction in a Turbulent Boundary Layer," NASA TT F-805, September 1974.
36. Laganelli, A. L., Foganoli, R. P., and Martellucci, A., "The Effects of Mass Transfer and Angle of Attack on Hypersonic Turbulent Boundary Layer Characteristics," AFFDL-TR 75-35, April 1975.
37. Foganoli, R. P. and Laganelli, A. L., "The Effect of Mach Number and Wall Temperature on Turbulent Heat Blockage Resulting from Mass Injection," AIAA Paper 77-784, 10th Fluid and Plasmadynamics Conf., June 1977.
38. Walker, G. K., "Turbulent Boundary Layers with Mass Addition," G. E. Document No. TFM-8151-021, November 1963.

where curve fits of the independent effects were applied both implicitly and explicitly. The results are shown in Figure 25. The first plot represents the data scatter from the independent curve fits, i.e., for the roughness only and blowing only data. The 2nd, 3rd, and 4th plots represent the application of the correlations to the data with combined roughness and blowing. Explicit relationships (Re_{K0} and λ_0 based on smooth-wall, non-blowing values of skin friction) were used to generate the 2nd plot whereas implicit relationships (Re_K and λ based on the resultant skin friction including the roughness and blowing effects) are depicted in the 3rd plot. Neither approach correlates the data to any degree of satisfaction. The explicit relationships (2nd plot) are in greatest error when the effects of the roughness and blowing are equal and opposite in value. Skin friction is generally underpredicted. The implicit relationships provide improved results, but the correlation appears to break down for high blowing rates. As it turns out, the only way to get any sort of reasonable results from using the independent correlations is to apply the roughness correlation first, using the implicit relationship, and obtain a value of the skin friction as if it were affected by roughness only. The next step is to apply the blowing correlation, using the explicit relationship, with the blowing parameter computed using the rough value of skin friction.

$$\frac{C_f}{C_{f0}} = f \left[Re_K(C_{fR}), \lambda_0(C_{fR}) \right] \quad (8)$$

Agreement between data and prediction using this scheme (see 4th plot) is found to be much better than for either of the previous techniques. For lack of a better method, this approach is suggested for design applications.

VELOCITY AND TEMPERATURE PROFILE DATA

The experimental results obtained from the boundary-layer profile measurements are presented and analyzed in this section. Typical velocity profiles are presented in Figure 26 for four different combinations of roughness and blowing. All of the profiles are for the same Reynolds number; one representing the smooth, non-blowing baseline condition, one with roughness, one with mass transfer, and one with combined roughness and blowing effects. All the profiles show a smooth monotonic decrease in velocity from the freestream value to the wall with no external disturbances noted. The effects of the roughness and blowing can be seen both in the thickness and shape of the boundary-layer profiles. Temperature profiles for the same test cases are presented in Figure 27. The results are plotted in the form of the generalized total temperature-velocity relationship of Danberg.³⁹ Two curves are plotted for comparison to the data. The linear or Crocco relation is derived for unit Prandtl number while the quadratic relation represents the adiabatic form of the Danberg³⁹ and Walz⁴⁰ temperature relationships. (This quadratic relation was used to reduce velocity profiles when temperature measurements were not made, i.e., for the high Reynolds number runs as discussed previously.) The general form of this relation can be expressed as:

39. Danberg, J. E., "Characteristics of the Turbulent Boundary Layer with Heat and Mass Transfer at $M = 6.7$," NOLTR 64-99, October 1964.

40. Walz, A., Boundary Layers of Flow and Temperature, MIT Press, Cambridge, Mass., 1969 (Library of Congress No. 69-12761).

$$\frac{T}{T_\infty} = A' + B' \left(\frac{U}{U_\infty}\right) + C' \left(\frac{U}{U_\infty}\right)^2 \quad (9)$$

where

$$A' = \frac{T_w}{T_\infty}$$

$$B' = \frac{T_{aw} - T_w}{T_\infty}$$

$$C' = \frac{T_\infty - T_{aw}}{T_\infty}$$

The temperature profile data presented for the different test conditions follows trends generally observed in adiabatic nozzle-wall flows.^{2, 4} The temperature overshoot at the outer edge of the boundary layer is as expected for adiabatic flow conditions and the data show trends which are in general agreement with the quadratic relation near the wall. The fact that the data for the different roughness and blowing conditions follows the same trend is enlightening. This similarity in the temperature-velocity relation has been noted by Reda⁶ for flows with roughness and by Danberg³⁹ for flows with mass transfer. As such, it is not unexpected in the present tests. It should be remembered, however, that the temperature profiles do differ, it is only the relationship between temperature and velocity that remains similar.

LAW-OF-THE-WALL-ANALYSES

Semi-empirical analyses of turbulent boundary layers are usually based on some form of the law-of-the-wall or law-of-the-wake correlation. Review papers by Clauser⁴¹ and Coles⁴² provide the in depth description of these correlation techniques. In general these correlations provide a means of dividing the turbulent velocity profile into regimes where different flow mechanisms are assumed to dominate. The wall law is defined most simply in terms of the dimensionless parameters:

$$U^+ = \frac{U}{U_\tau} \quad \text{and} \quad Y^+ = \frac{YU_\tau}{\nu} \quad (10)$$

Within the turbulent boundary layer, three distinct regions are found to exist, the laminar sublayer, the logarithmic region and the wake or velocity-defect region. The general form of the relationships governing these regimes for smooth-wall, non-blown boundary layers is given by:

-
41. Clauser, F. H., "The Turbulent Boundary Layer," *Advances in Applied Mechanics*, Vol. IV, 1956, pp. 1051.
42. Coles, D., "The Law of the Wake in the Turbulent Boundary Layer," *J. Fluid Mechanics*, Vol. 1, 1956, pp. 191-226.

$$U^+ = Y^+ \quad \text{for } Y^+ < 11 \quad (11)$$

$$U^+ = \frac{1}{\kappa} \ln Y^+ + C + \frac{\Pi}{\kappa} \omega\left(\frac{Y^+}{8}\right) \quad \text{for } Y^+ > 11 \quad (12)$$

where κ is the Karman constant, ω is Coles wake function, and Π is the wake parameter.

For compressible flows a transformation is utilized to account for the density variation through the boundary layer. The analysis of Van Driest⁴³ is generally accepted⁴⁴ for flows without mass transfer and is given in the form:

$$U^+ = \frac{U^*}{U_\tau} = \frac{U_\infty}{U_\tau A} \left\{ \sin^{-1} \left[\frac{2A^2 \frac{U}{U_\infty} - B}{\sqrt{B^2 + 4A^2}} \right] + \sin^{-1} \left[\frac{B}{\sqrt{B^2 + 4A^2}} \right] \right\} \quad (13)$$

where

$$A^2 = \frac{T_{aw} - T_\infty}{T_w}$$

$$B = \frac{T_{aw} - T_w}{T_w}$$

The transformed velocity profiles for the smooth-wall, non-blowing baseline condition are shown in Figure 28 for the range of Reynolds numbers tested. In each case, the profiles followed the expected trends. By curve fitting the logarithmic portion of each of the profiles, the constants κ , C , and Π in Equation 12 could be evaluated. The results are shown in Figure 29. The flagged data points represent profiles which were obtained with a direct measurement of the temperature profile. As such, the selection of the nominal values for the constants was based heavily on these three profiles. Nominal values of the three constants were:

$$\kappa = 0.4, C = 5.5, \text{ and } \Pi = 0.9.$$

The first two values are in agreement with generally accepted incompressible results and follow the trends noted by Danberg.³⁹ The wake parameter is higher than incompressible results but is typical of the trends recently noted by Danberg⁴⁵ for higher Mach number flows along nozzle walls.

-
43. Van Driest, E. R., "Turbulent Boundary Layer in Compressible Fluids," J. Aeronautical Sciences, Vol. 18, No. 3, March 1951, pp. 145-160, 216.
44. Hopkins, E. J., Keener, E. R., Polek, T. E., and Dwyer, H. A., "Hypersonic Turbulent Skin-Friction and Boundary Layer Profiles on Nonadiabatic Flat Plates," AIAA Journal, Vol. 10, No. 1, January 1972, pp. 40-48.
45. Danberg, J. E., "Some Supersonic Wind Tunnel Boundary Layer Characteristics," Ballistic Research Lab Memo, Rpt. No. 2618, April 1976.

THE LAW-OF-THE-WALL WITH ROUGHNESS AND BLOWING

The effect of roughness on incompressible law-of-the-wall profiles has been shown by Hama¹⁸ to result solely in a shift in the intercept constant, C, in Equation 12. For compressible flows this same result has been noted provided the profiles are transformed to account for the density variation through the boundary layer. The Van Driest form of the transformation, Equation 13, has been used by Reda⁶ and Berg²² for compressible rough-wall profiles with much success. A typical profile with roughness is shown plotted in Figure 30. Shown for comparison are the smooth-wall relations given by Equations 11 and 12 and the shifted rough wall fit to the logarithmic region of the profile. Also shown is the evaluation of the rough wall profiles using different origins for the y coordinate. Since the Pitot pressure measurements can only be made to the top of the screen roughness elements, the profiles had to be shifted to an effective origin which was located between the top and bottom of the roughness elements. Examination of all the rough, non-blown profiles showed that an effective origin equal to 0.7 times the roughness height provided for a straight line fit (in semi-logarithmic coordinates) of the logarithmic portion of the profiles with a slope equal to the inverse of the Karman constant ($\kappa = 0.4$). This value for the effective origin was consistent with values of 0.7 and 0.8 given by Moore⁴⁶ and Perry and Joubert⁴⁷ for two-dimensional roughness and values of 0.5 given by Reda⁶ and Berg²² for sand grain and two-dimensional roughness elements, respectively, in supersonic flow. The effective origin would be expected to vary with roughness geometry, pattern, and density, however, this correlation has not been established.

The law-of-the-wall has been extended to include blowing effects with the theories given by Stevenson⁴⁸ and Simpson⁴⁹ being the more noted. Stevenson's approach is used in this analysis based on its general similarity to the previously used form of the law-of-the-wall relation. For incompressible flows, the relation is given by

$$U^+ = \frac{2U_\tau}{V_w} \left[\sqrt{1 + \frac{V_w U}{U_\tau^2}} - 1 \right] = \frac{1}{\kappa} \ln Y^+ + C \quad (14)$$

This relation has the same form as Equation 12 with Stevenson showing from his experiments that the parameters κ and C are identical to the non-blowing values

46. Moore, W. F., "An Experimental Investigation of the Boundary Layer Development Along a Rough Surface." Ph.D. Dissertation, State University of Iowa, 1951.
47. Perry, A. E., and Joubert, P. N., "Rough-Wall Boundary Layers in Adverse Pressure Gradients," J. Fluid Mechanics, Vol. 17, 1963, pp. 193-211.
48. Stevenson, T. N., "A Law of the Wall for Turbulent Boundary Layers with Suction or Injection," the College of Aeronautics, Cranfield CoA Rpt. Aero No. 166, July 1963.
49. Simpson, R. L., "Characteristics of Turbulent Boundary Layers at Low Reynolds Numbers with and without Transpiration," J. Fluid Mech., Vol. 42, Part 4, pp. 769-802, 1970.

and independent of injection velocity. In order to account for compressibility in the law-of-the-wall with blowing, the approach suggested by Danberg³⁹ was used. A coordinate transformation is applied in the form:

$$U^+ = \frac{U^*}{U_\tau} = \int \frac{\sqrt{\frac{\rho}{\rho_w}}}{\sqrt{1 + \lambda \frac{U}{U_\infty}}} d\left(\frac{U}{U_\tau}\right) \quad (15)$$

where λ is the blowing parameter. Using this approach, a density-velocity relationship is introduced, and Equation 15 is integrated to obtain the desired transformation in terms of velocity only. (This same approach can be used to develop the zero-mass-transfer results of Van Driest which were presented in Equation 13. The integrations of Equation 15 with λ equal to zero results in the inverse sine functions noted in that transformation.) For the more general case with blowing, the integration of Equation 15 is more tedious. It has been performed by Rubesin,³² however. Using the same density-velocity relation which was used in the Van Driest formulation, i.e.,

$$\frac{\rho_w}{\rho} = \frac{T}{T_w} = 1 + B \frac{U}{U_\infty} - A^2 \left(\frac{U}{U_\infty}\right)^2 \quad (16)$$

with A and B defined as in Equation 13, the integration of Equation 15 can be performed. The result is given by:

$$U^+ = \frac{2}{A} \frac{U_\infty}{U_\tau} \frac{1}{\sqrt{\lambda(\beta-\alpha)}} \left\{ F \left[K_n, \phi\left(\frac{U}{U_\infty} = 0\right) \right] - F \left[K_n, \phi\left(\frac{U}{U_\infty} = 1\right) \right] \right\} \quad (17a)$$

when $K_n^2 = \frac{\beta + \sigma}{\beta - \alpha} < 1$

$$\sin^2 \phi = \frac{\beta - \frac{U}{U_\infty}}{\beta + \sigma}$$

or

$$U^+ = \frac{2}{A} \frac{U_\infty}{U_\tau} \frac{1}{\sqrt{\lambda(\beta+\sigma)}} \left\{ F \left[K_n, \phi\left(\frac{U}{U_\infty} = 0\right) \right] - F \left[K_n, \phi\left(\frac{U}{U_\infty} = 1\right) \right] \right\} \quad (17b)$$

when $K_n^2 = \frac{\beta - \alpha}{\beta + \sigma} < 1$

$$\sin^2 \phi = \frac{\beta - \frac{U}{U_\infty}}{\beta - \alpha}$$

with

$$F[K_n, \phi] = \int_0^{\phi} \frac{d\phi}{\sqrt{1 - K_n^2 \sin^2 \phi}}$$

being an elliptical integral of the first kind and

$$\alpha = \frac{B - \sqrt{B^2 + 4A^2}}{2A^2}$$

$$\beta = \frac{B + \sqrt{B^2 + 4A^2}}{2A^2}$$

$$\sigma = 1/\lambda$$

Each of the profiles was transformed using one of the two compressibility transformations noted, Equation 13 for the non-blowing profiles and Equation 17 for the profiles with blowing. Each profile was then plotted in the U^+ vs. Y^+ semi-logarithmic form and a curve fit of the logarithmic region of the profile was made. For all cases the effective origin of the profile was located at a point 0.7 times the roughness height.

Typical law-of-the-wall plots for velocity profiles with roughness and blowing effects are presented in Figures 31 and 32, respectively. It is encouraging to note how similar the velocity profiles look under the influence of the transformations, Equations 13 and 17. In the wake region of the profiles the parameter, Π , remains essentially unchanged over the whole range of roughness and blowing conditions. There is no difficulty in fitting the logarithmic portion of the profile with a line of slope, $1/\kappa$, and determining the intercept constant, C . With roughness and blowing the velocity profiles are observed to shift downward from the smooth-wall, non-blowing curve. The shifts in the profile intercept constant were evaluated by using a modified form of Equation 12 given by

$$U^+ = \frac{1}{\kappa} \ln Y^+ + C - \Delta C_R - \Delta C_B \quad (18)$$

where ΔC_R and ΔC_B are the relative shifts in the profile constant with roughness and blowing, respectively; and κ and C are the smooth-wall, non-blowing values given previously.

For a roughness of a given type, i.e., geometry, pattern, and density, the shift in the profile intercept constant has been shown^{6,11,22} to be a function of the roughness Reynolds number alone, independent of Mach number. The results of the present evaluation are consistent with that supposition as illustrated

in Figure 33. All of the ΔC_R data are presented for profiles with roughness effects only, no blowing. Shown for comparison are the Mach 2.9 data of Reda⁶ for sand grain roughness, and the incompressible results of Nikuradse¹⁷ and Hama¹⁸ for sand grain and screen roughness, respectively. The data can be correlated in terms of the roughness regimes as described in Equation 3. Below $Re_K = 5$, no effect on the profile is noticed. Above $Re_K = 70$, in the fully rough regime, the relation is of the form

$$\Delta C_R = \frac{1}{K} \ln (Re_K) + D \quad (19)$$

where D is a constant which is a function of the roughness type only. For sand grain roughness the incompressible pipe flow data of Nikuradse¹⁷ is generally accepted as the norm and the constant D equals -3.0. For screen type roughness and other roughness geometries, patterns, and densities, the constant D takes on new values. These have been correlated by Dvorak,⁵⁰ Simpson⁵¹ and Dirling⁵² in a variety of ways. A convenient method of describing a roughness is to determine its equivalent sand-grain value, K_s . This value is defined as the sand grain roughness which would be necessary to produce the same ΔC_R and correspondingly the same C_f as the particular test sample produces. The ratio K_s/K is related to the D value by:

$$\frac{K_s}{K} = e^{K(D+3)}. \quad (20)$$

This relation is depicted in Figure 33. By fitting the present ΔC_R data in the fully rough regime (dashed line, Figure 33), the equivalent sand grain roughness for the screen material can be determined. A K_s/K value of 1.22 is indicated. Hama's results for a screen type roughness were quite different, $K_s/K = 1.8$. These results do not contradict each other, however, because the roughness spacing and pattern as well as the roughness geometry are different. As it turns out, the ratio of the screen mesh spacing to mesh height in Hama's experiments was approximately twice that of the present tests. In addition, the orientation of the wire mesh to the flow was different. Most of the theories,^{50,51,52} would predict an increase in the K_s value with increasing roughness spacing in the range noted. However, the representation of the screen weave is difficult to model geometrically and no direct correlations are attempted. In general, the roughness characteristics noted for the screen material are very similar to classical sand grain results.

According to Stevenson,⁴⁸ the modified law-of-the-wall relation with blowing, Equation 14, should transform the velocity profiles with blowing identically to

-
50. Dvorak, F. A., "Calculation of Turbulent Boundary Layers on Rough Surfaces in Pressure Gradient." AIAA J., Vol. 7, No. 9, pp. 1752-1759, September 1969.
 51. Simpson, R. L., "A Generalized Correlation of Roughness Density Effects on the Turbulent Boundary Layer," AIAA, Vol. 11, No. 2, pp. 242-244, 1973.
 52. Dirling, R. B., Jr., "A Method for Computing Roughwall Heat Transfer Rates on Reentry Nosetips," AIAA Paper No. 73-763, 8th Thermophysics Conference, July 1973.

the non-blowing form. This result is not generally accepted, however, and variations in the intercept constant, C , have been noted.^{39,53} Danberg³⁹ evaluated his Mach 6.5 results and found that the parameter C shifted with injection rate in a manner very similar to the effects noted for roughness. The present results show a similar trend as noted in Figure 32. The shift in the intercept constants due to blowing, ΔC_B , is presented in Figure 34 as a function of the blowing parameter, λ . Data are presented which include roughness effects. In these cases, the ΔC_B values represent the additional shift in profile intercept constant above the values shifted due to roughness. The results presented in Figure 34 show a Mach number dependence with extrapolation to the incompressible case indicating a ΔC_B equal to zero. This result has also been noted by Squire⁵³ and would provide a consistency with Stevenson's⁴⁸ initial observations.

Empirically correlated velocity profiles such as the law-of-the-wall can be converted to skin-friction relations as was done by Fenter¹² and Rubesin²⁷ for roughness and blowing effects, respectively. Based on the encouraging results noted in this analysis, the expectations are optimistic that theories of this type can be formulated to include the combined effects of both roughness and blowing.

53. Squire, L. C., "A Law of the Wall for Compressible Turbulent Boundary Layers with Air Injection," J. Fluid Mech., Vol. 37, Part 3, pp. 449-456, 1969.

IV. CONCLUSIONS

The relative and combined effects of surface roughness and mass transfer on compressible turbulent boundary-layer profiles and skin friction were experimentally evaluated at a Mach number of 2.9. Specialized test equipment was utilized including porous roughened test plates and an active-blowing skin-friction balance. Roughness conditions ranged from the aerodynamically smooth to full roughy regime and blowing conditions reached levels up to and including boundary-layer blow-off. Based on the analysis of the experimental data, the following results and conclusions are summarized:

1. The roughness Reynolds number, Re_k , was found to be the primary correlating parameter for evaluating roughness effects on skin friction and velocity profiles, whereas the blowing parameter, λ_0 , was primary in evaluating mass transfer effects.
2. The relative effects of roughness and blowing on skin friction could be predicted using established theories, however, the use of these independent correlations to predict the combined effects was not as straightforward.
3. Blowing effects on skin friction showed no identifiable Mach number dependence. This result is consistent for flat plate results but is in disparity with cone data.
4. The temperature-velocity relationship was found to be representative of adiabatic nozzle-wall boundary-layer flows. In addition, no significant roughness or blowing effects were noted in the correlation.
5. Law-of-the wall compressibility transformations were presented for both blowing and non-blowing conditions with roughness. The similarity of the transformed velocity profiles with incompressible results was very encouraging.
6. The effect of roughness on the law-of-the-wall was to cause a downward shift in the profiles with increased roughness. Data correlated well with incompressible results. The equivalent sand grain roughness of the screen surface was evaluated and a screen roughness similarity was suggested in terms of the ratio of the mesh spacing to roughness height.
7. The effect of blowing on the law-of-the-wall profiles was to cause an additional downward shift in the profiles from that noted with roughness. This shift could be correlated in terms of the blowing parameter, λ .

REFERENCES

1. Lee, R. E., et al., "The NOL Boundary Layer Channel," NOLTR 66-185, Nov. 1966.
2. Voisinet, R. L. P. and Lee, R. E., "Measurements of a Mach 4.9 Zero-Pressure-Gradient Turbulent Boundary Layer with Heat Transfer - Part 1, Data Compilation," NOLTR 72-232, Sep 1972.
3. Voisinet, R. L. P. and Lee, R. E., "Measurements of a Supersonic Favorable-Pressure-Gradient Turbulent Boundary Layer with Heat Transfer - Part 1, Data Compilation," NOLTR 73-223, Dec 1973.
4. Voisinet, R. L. P., Lee, R. E. and Yanta, W. J., "An Experimental Study of the Compressible Turbulent Boundary Layer with an Adverse Pressure Gradient," Paper No. 9, Turbulent Shear Flows, AGARD CP-93-71, Sep 1971.
5. Voisinet, R. L. P., "An Experimental Investigation of the Compressible Turbulent Boundary-layer Separation Induced by a Continuous Flow Compression," Paper No. 19, Flow Separation, AGARD CP-168, May 1975.
6. Reda, D. C., "Compressible Turbulent Skin Friction on Rough and Rough/Wavy Walls in Adiabatic Flow," NOLTR 74-34, Feb 1974. Also AIAA Journal Vol. 13, No. 5, May 1975, pp. 553-554.
7. Voisinet, R. L. P. and Young, T. J., "A Skin-Friction Balance for Roughness and Blowing Studies," AIAA Paper 78-780, 10th Aerodynamic Testing Conference, April 1978.
8. Voisinet, R. L. P., "Combined Influence of Roughness and Mass Transfer on Turbulent Skin Friction at Mach 2.9, AIAA Paper 79-0003, 17th Aerospace Sciences Meeting, Jan 1979.
9. Bruno, J. R., et. al., "Balance for Measuring Skin Friction in the Presence of Heat Transfer", NOLTR 69-56, Jun 1969.
10. Chien, K., "Hypersonic Turbulent Cold-Wall Skin-Friction and Heat-Transfer Measurements on an Axisymmetric Sharp Cone", NOLTR 73-108, Jun 1973.
11. Horanoff, E. V. and Driftmyer, R. T., "Two-Component Force Balance for Measuring Skin Friction and Side Force", NSWC/WOL/TR 75-174, Oct 1975.

References (Cont'd)

12. Voisinet, R. L. P., "Temperature Step Effects on Direct Measurement of Skin-Friction Drag", NSWC/WOL/TR 77-7, 1977.
13. Ezekiel, F. D., "Uses of Magnetic Fluids in Bearings, Lubrication, and Damping", ASME Paper 75-DE-5, 1975.
14. Moskowitz, R., "Designing with Ferro-magnetic Fluids", ASME Paper 74-DE-5, 1974 and reprinted in Mechanical Engineering, Feb 1975.
15. Yanta, W. J., "A Fine-Wire Stagnation Temperature Probe," NOLTR 70-81, Jun 1970.
16. Spalding, D. B., and Chi S. W., "The Drag of a Compressible Turbulent Boundary Layer on a Smooth Flat Plate with and without Heat Transfer," J. Fluid Mechanics, Vol. 18, Part I, Jan. 1964, pp. 117-143.
17. Nikuradse, J., "Laws of Flow in Rough Pipes," English translation, NACA TM No. 1292, Nov. 1950.
18. Hama, F. R., "Boundary Layer Characteristics for Smooth and Rough Surfaces," Transactions Society Naval Architects Marine Engineers, Vol. 62, 1954, pp. 333-358.
19. Fenter, F. W., "The Turbulent Boundary Layer on Uniformly Rough Surfaces at Supersonic Speeds," Vought Research Center, Rpt. No. RE-E9R-2, Dec 1959.
20. Goddard, F. E., Jr. "Effect of Uniformly Distributed Roughness on Turbulent Skin-Friction Drag at Supersonic Speed," J. Aeronautical Sciences, Vol. 26, No. 1, pp. 1-15, Jan 1959.
21. Young, F. L., "Experimental Investigation of the Effects of Surface Roughness on Compressible Turbulent Boundary Layer Skin Friction and Heat Transfer," Defense Research Laboratory Report DRL-532, May 1965.
22. Berg, D. E., "Surface Roughness Effects on the Hypersonic Turbulent Boundary Layer," SAND77-0587, Sandia Laboratories, Albuquerque, New Mexico, Sep 1977.
23. Jeromin, L. O. F., "The Status of Research in Turbulent Boundary Layers with Fluid Injection," Progress in Aeronautical Sciences, Vol. 10, pp. 65-189, 1970.
24. Kendall, R. M., Rubesin, M. W., Dahm, T. J., Mendenhall, M. R., "Mass, Momentum, and Heat Transfer Within a Turbulent Boundary Layer with Foreign Gas Mass Transfer at the Surface," Vidya Report No. 111, February 1964.
25. Goodwin, B. M., "The Transpired Turbulent Boundary Layer with Zero Pressure Gradient," MIT Doctor of Science Thesis, May 1961.

References (Cont'd)

26. Simpson, R. L., Moffat, R. J. and Kays, W. M., "The Turbulent Boundary Layer on a Porous Plate: Experimental Skin Friction with Variable Injection and Suction," *Int. J. Heat Mass Transfer*, Vol. 12, pp. 771-789, 1969.
27. Dershin, H., Leonard, C. A., and Gallaher, W. H., "Direct Measurement of Skin Friction on a Porous Flat Plate with Mass Injection," *AIAA Journal*, Vol. 5, No. 11, 1967.
28. Pappas, C. C., Okuno, A. F., "Measurement of Skin Friction of the Compressible Turbulent Boundary Layer on a Cone With Foreign Gas Injection," *Journal of the Aero/Space Sciences*, Volume 27, No. 5, May 1960.
29. Baronti, F., Fox H., and Soll, D., "A Survey of Compressible Turbulent Boundary Layer with Mass Transfer," *Astronautica Acta*, Vol. 13, pp. 239-248, 1967.
30. Crocco, L., "An Approximate Theory of Porous, Sweat, or Film Cooling with Reactive Fluids," *J. American Rocket Society*, Vol. 22, pp. 331-338, 1952.
31. Kays, W. M. and Moffat, R. J., "The Behavior of Transpired Turbulent Boundary Layers," Stanford University, Report No. HMT-20, April 1975.
32. Rubesin, M. W., "An Analytical Estimation of the Effect of Transpiration Cooling on the Heat-Transfer and Skin-Friction Characteristics of a Compressible Turbulent Boundary Layer," NACA TN 3341, December 1954.
33. Dorrance, W. H., and Dore, F. J., "The Effect of Mass Transfer on the Compressible Turbulent Boundary-Layer Skin Friction and Heat Transfer," *J. Aeronautical Sciences*, June 1954.
34. Kutateladze, S. S. and Leont'yev, A. I., Turbulent Boundary Layers in Compressible Gases, Academic Press, New York, 1964.
35. Kutateladze, S. S., and Leont'yev, A. I., "Heat-Mass Transfer and Friction in a Turbulent Boundary Layer," NASA TT F-805, September 1974.
36. Laganelli, A. L., Foganoli, R. P., and Martellucci, A., "The Effects of Mass Transfer and Angle of Attack on Hypersonic Turbulent Boundary Layer Characteristics," AFFDL-TR 75-35, April 1975.
37. Foganoli, R. P. and Laganelli, A. L., "The Effect of Mach Number and Wall Temperature on Turbulent Heat Blockage Resulting from Mass Injection," AIAA Paper 77-784, 10th Fluid and Plasmadynamics Conf., June 1977.
38. Walker, G. K., "Turbulent Boundary Layers with Mass Addition," G. E. Document No. TFM-8151-021, November 1963.
39. Danberg, J. E., "Characteristics of the Turbulent Boundary Layer with Heat and Mass Transfer at $M = 6.7$," NOLTR 64-99, October 1964.

References (Cont'd)

40. Walz, A., Boundary Layers of Flow and Temperature, MIT Press, Cambridge, Mass., 1969 (Library of Congress No. 69-12761).
41. Clauser, F. H., "The Turbulent Boundary Layer," *Advances in Applied Mechanics*, Vol. IV, 1956, pp. 1051.
42. Coles, D., "The Law of the Wake in the Turbulent Boundary Layer," *J. Fluid Mechanics*, Vol. 1, 1956, pp. 191-226.
43. Van Driest, E. R., "Turbulent Boundary Layer in Compressible Fluids," *J. Aeronautical Sciences*, Vol. 18, No. 3, March 1951, pp. 145-160, 216.
44. Hopkins, E. J., Keener, E. R., Polek, T. E., and Dwyer, H. A., "Hypersonic Turbulent Skin-Friction and Boundary Layer Profiles on Nonadiabatic Flat Plates," *AIAA Journal*, Vol. 10, No. 1, January 1972, pp. 40-48.
45. Danberg, J. E., "Some Supersonic Wind Tunnel Boundary Layer Characteristics," *Ballistic Research Lab Memo*, Rpt. No. 2618, April 1976.
46. Moore, W. F., "An Experimental Investigation of the Boundary Layer Development Along a Rough Surface." Ph.D. Dissertation, State University of Iowa, 1951.
47. Perry, A. E., and Joubert, P. N., "Rough-Wall Boundary Layers in Adverse Pressure Gradients," *J. Fluid Mechanics*, Vol. 17, 1963, pp. 193-211.
48. Stevenson, T. N., "A Law of the Wall for Turbulent Boundary Layers with Suction or Injection," *the College of Aeronautics, Cranfield CoA Rpt. Aero No. 166*, July 1963.
49. Simpson, R. L., "Characteristics of Turbulent Boundary Layers at Low Reynolds Numbers with and without Transpiration," *J. Fluid Mech.*, Vol. 42, Part 4, pp. 769-802, 1970.
50. Dvorak, F. A., "Calculation of Turbulent Boundary Layers on Rough Surfaces in Pressure Gradient." *AIAA J.*, Vol. 7, No. 9, pp. 1752-1759, September 1969.
51. Simpson, R. L., "A Generalized Correlation of Roughness Density Effects on the Turbulent Boundary Layer," *AIAA*, Vol. 11, No. 2, pp. 242-244, 1973.
52. Dirling, R. B., Jr., "A Method for Computing Roughwall Heat Transfer Rates on Reentry Nostetips," *AIAA Paper No. 73-763*, 8th Thermophysics Conference, July 1973.
53. Squire, L. C., "A Law of the Wall for Compressible Turbulent Boundary Layers with Air Injection," *J. Fluid Mech.*, Vol. 37, Part 3, pp. 449-456, 1969.

TABLE 1 POROUS ROUGHENED TEST SAMPLES

MULTILAYER COMPOSITE	TYPICAL ALL PANELS		
PERFORATED PLATE	22-GAGE 1.58 mm DIA HOLES ON 4.76 mm CENTERS 60° STAGGERED PATTERN 0.762 mm THICKNESS		
DISTRIBUTION MESH	20 MESH, 0.406 mm DIA WIRES 0.584 mm THICKNESS		
FIVE-LAYER DUTCH WEAVE	5 LAYERS 50 x 250 MESH DUTCH WEAVE 0.864 mm THICKNESS		
ROUGHNESS SCREENS	1	2	3
K-(mm/INCH)	0.1/0.004	0.33/0.013	1.25/0.049
d_w -WIRE DIA (mm)	0.05842	0.1905	0.7112
MESH (WIRES PER INCH)	200	60	14
S- MESH SPACING (mm)	0.127	0.4233	1.8143
S/ d_w	2.174	2.22	2.551
S/K	1.25	1.28	1.46
% CALENDAR	13.0	13.3	12.5

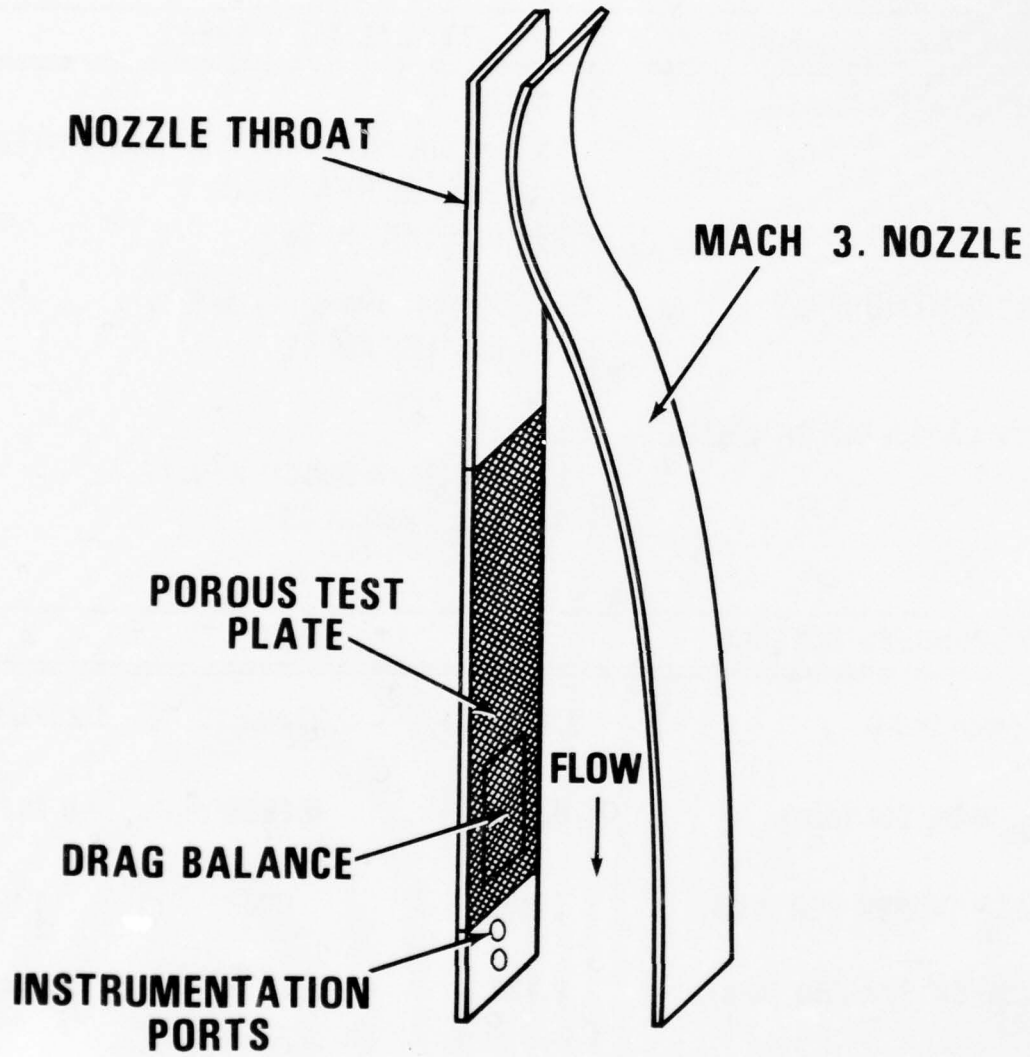

FIGURE 1 NSWC BOUNDARY LAYER CHANNEL

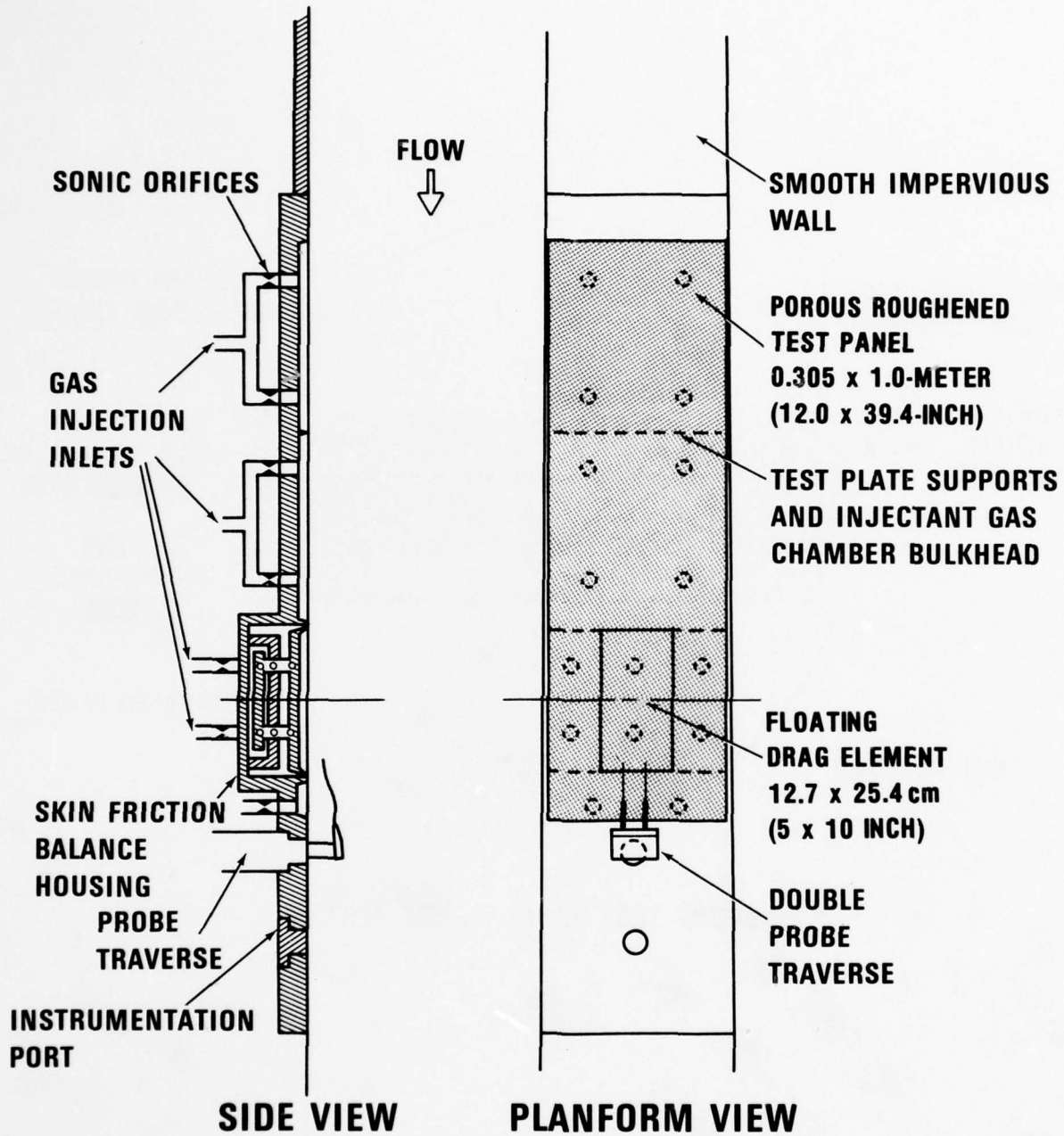

FIGURE 2 TEST PLATE SETUP AND APPARATUS

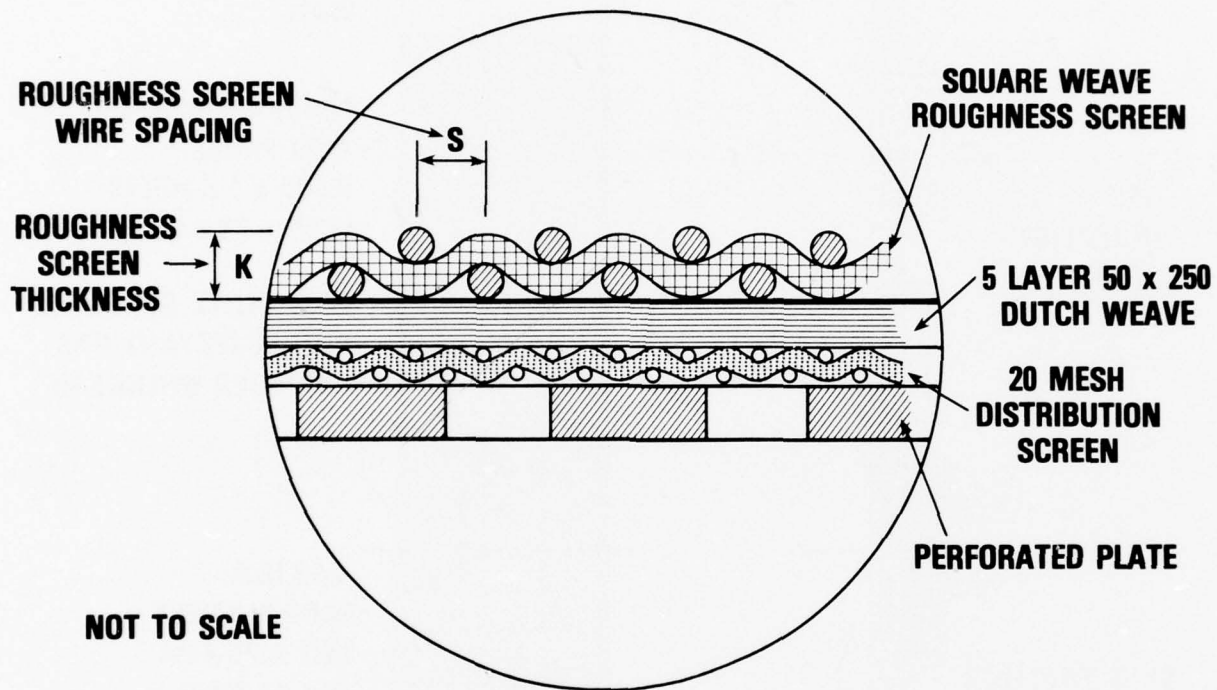
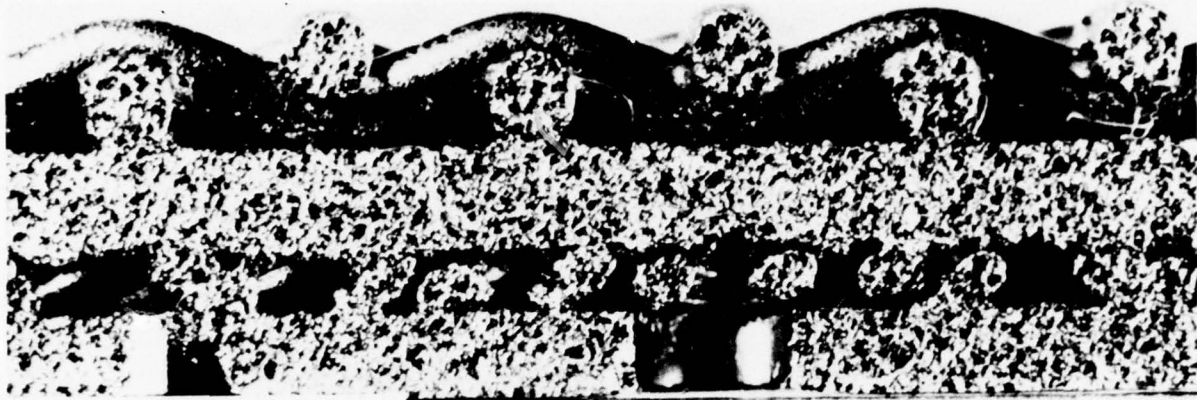

FIGURE 3 TEST PANEL. CROSS SECTION



PANEL NO. 3
K = 1.25 mm (0.049 INCH)



PANEL NO. 2
K = 0.33 mm (0.013 INCH)



PANEL NO. 1
K = 0.1 mm (0.004 INCH)

0.397 mm

FIGURE 4a TEST PANEL CROSS SECTIONS, PHOTOGRAPHS

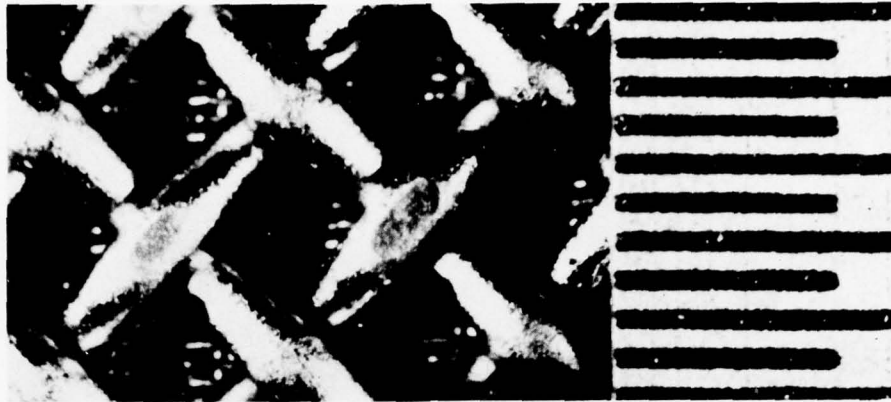

PANEL NO. 3 $K=1.25$ mm (0.049 INCH)

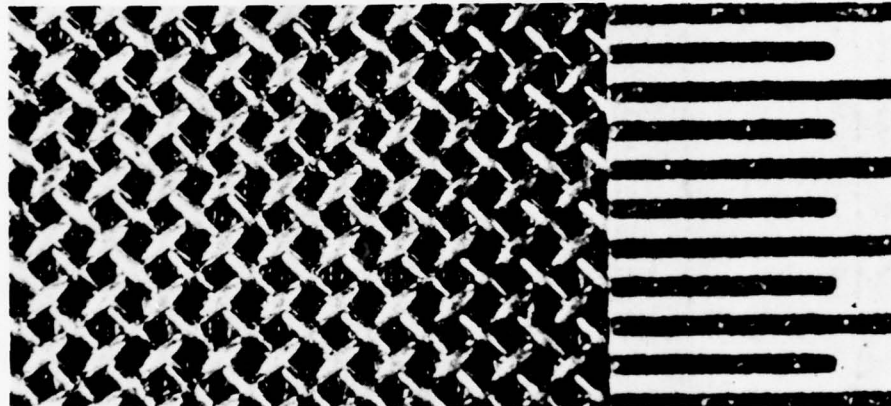

PANEL NO. 2 $K=0.33$ mm (0.013 INCH)

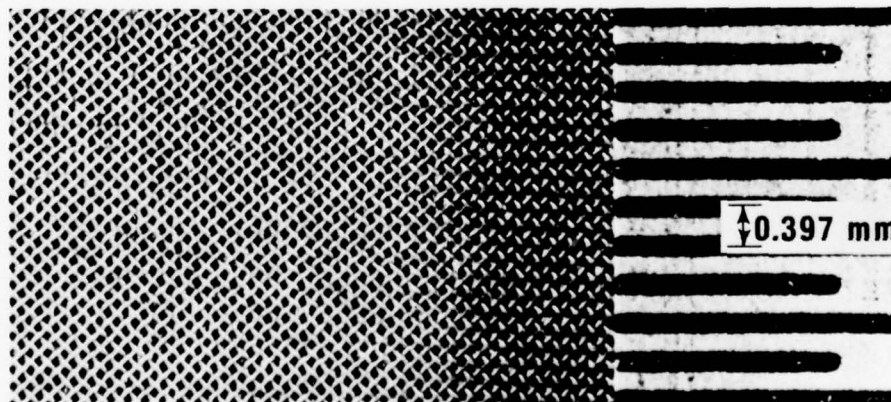

PANEL NO. 1 $K=0.1$ mm (0.004 INCH)

FIGURE 4b TEST PANEL PLANFORM VIEWS, PHOTOGRAPHS

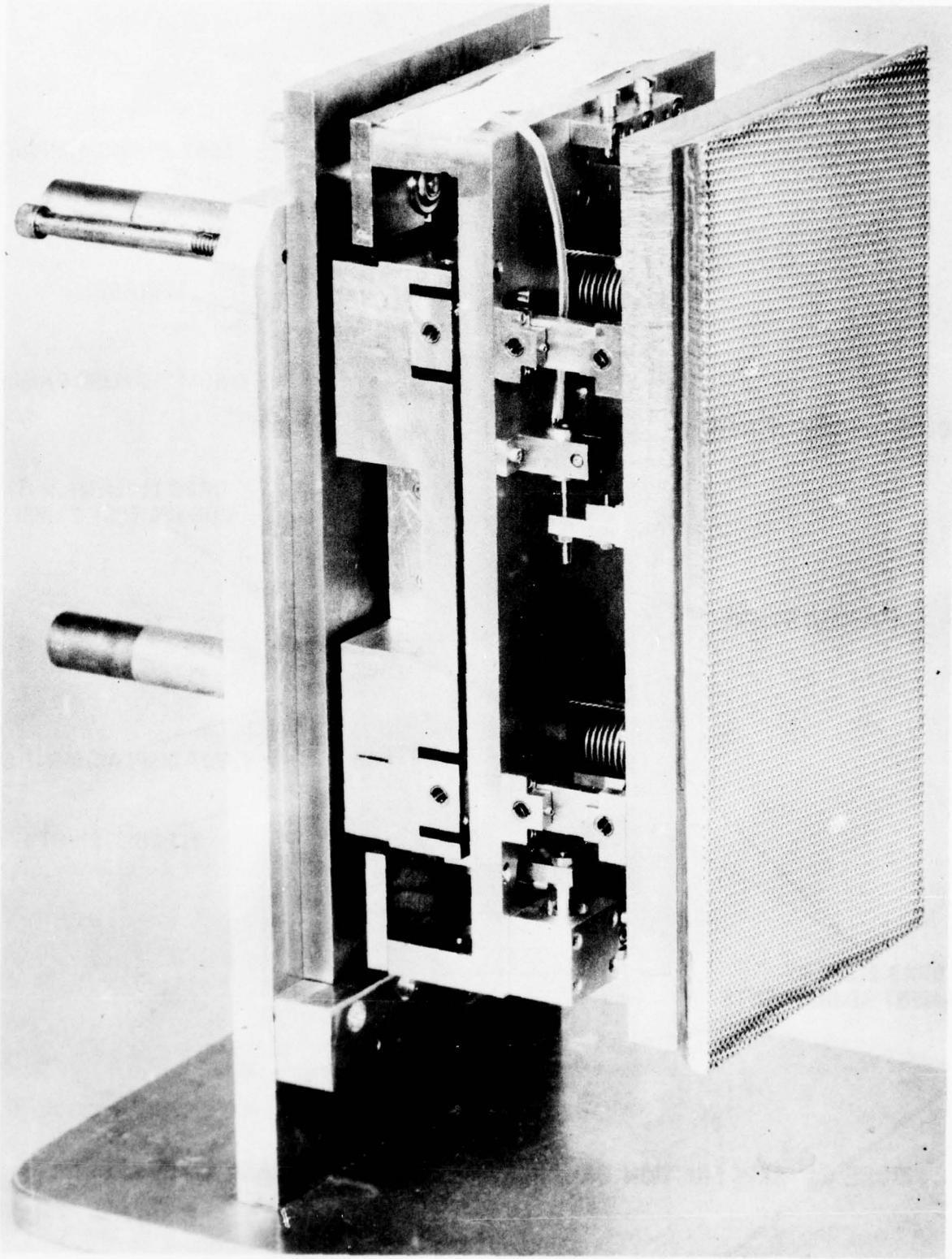

FIGURE 5 SKIN FRICTION BALANCE, PHOTOGRAPH

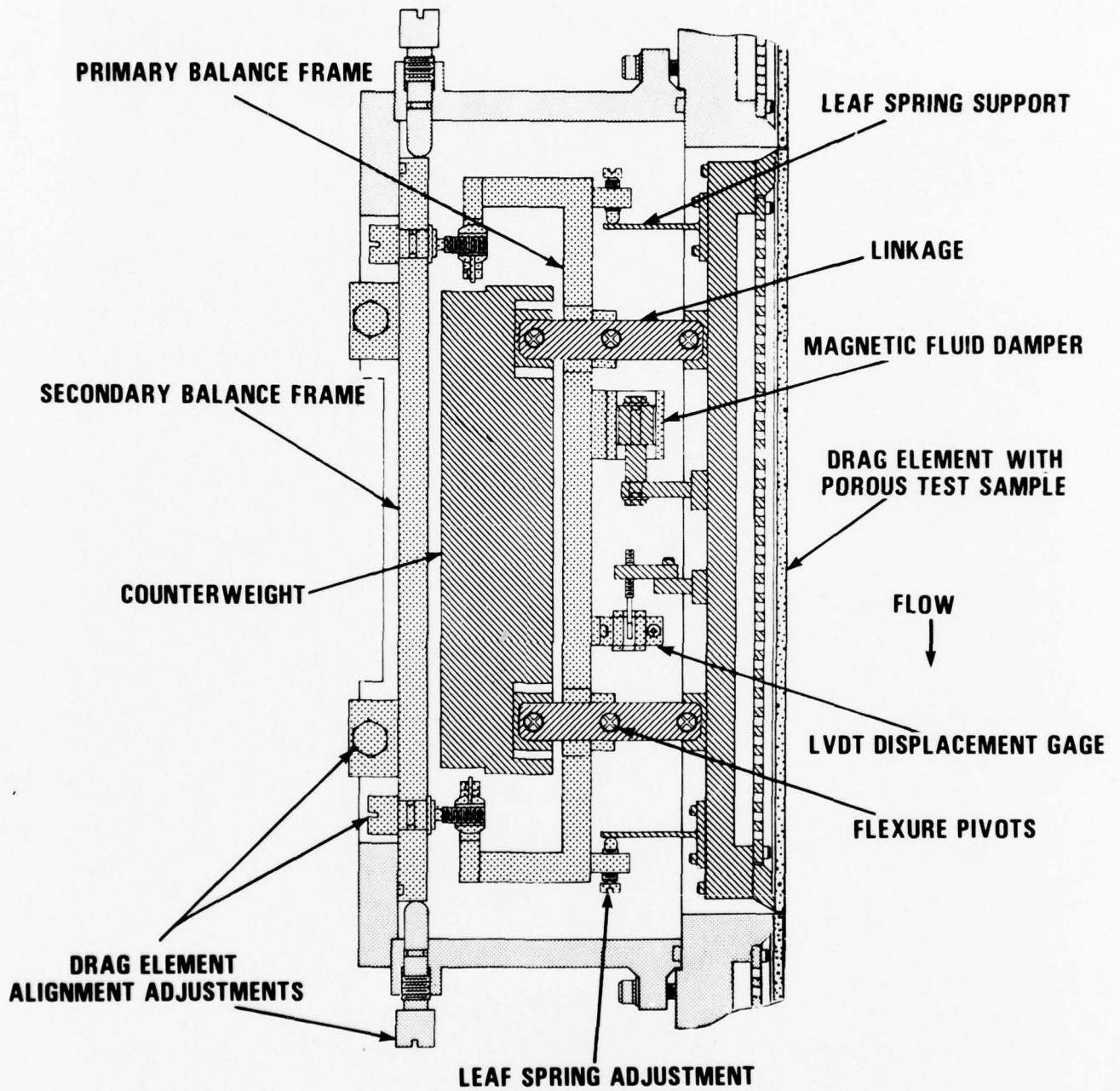

FIGURE 6a SKIN FRICTION BALANCE SCHEMATIC, MECHANICAL COMPONENTS

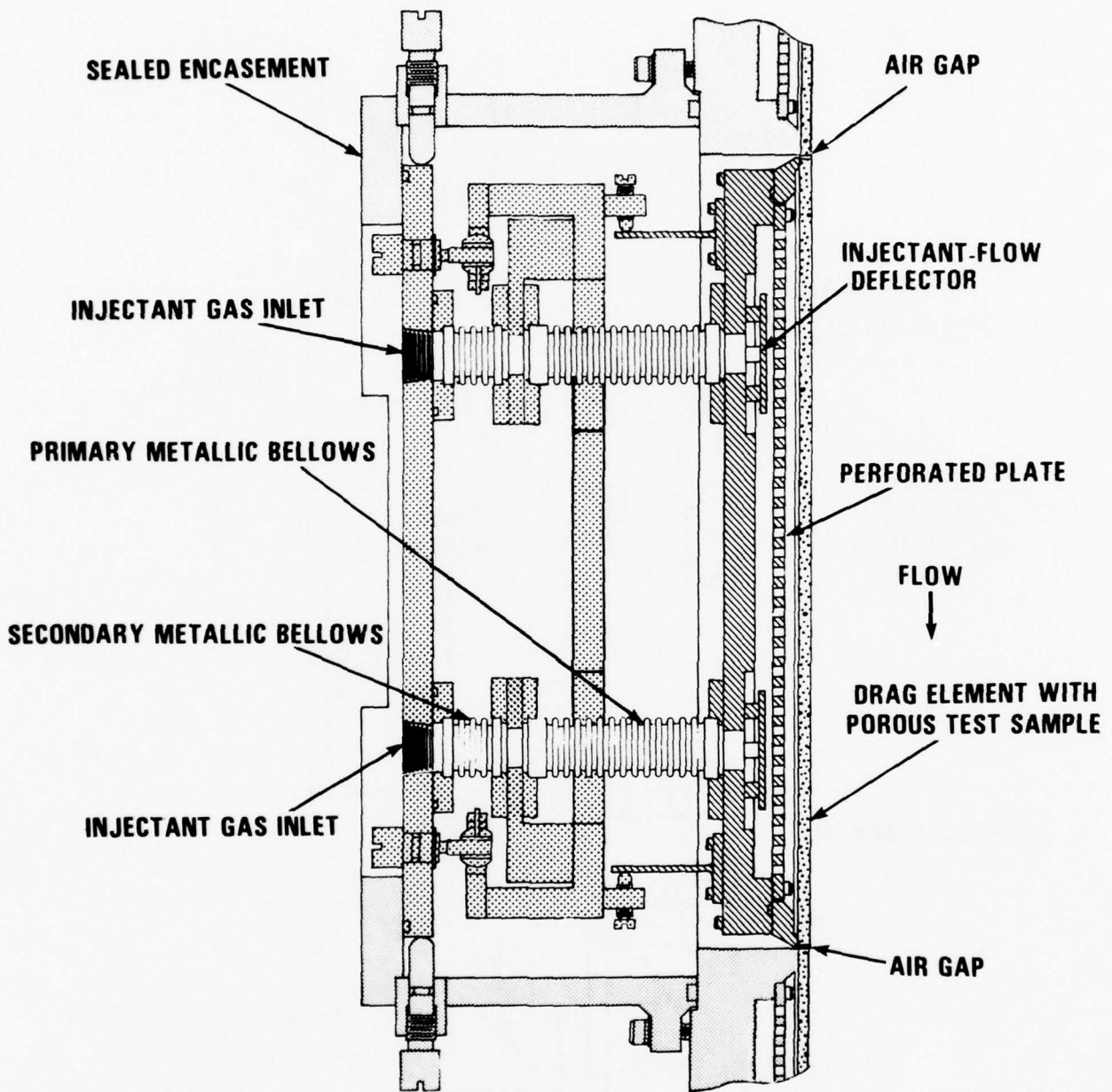

FIGURE 6b SKIN FRICTION BALANCE SCHEMATIC, GAS INJECTION COMPONENTS

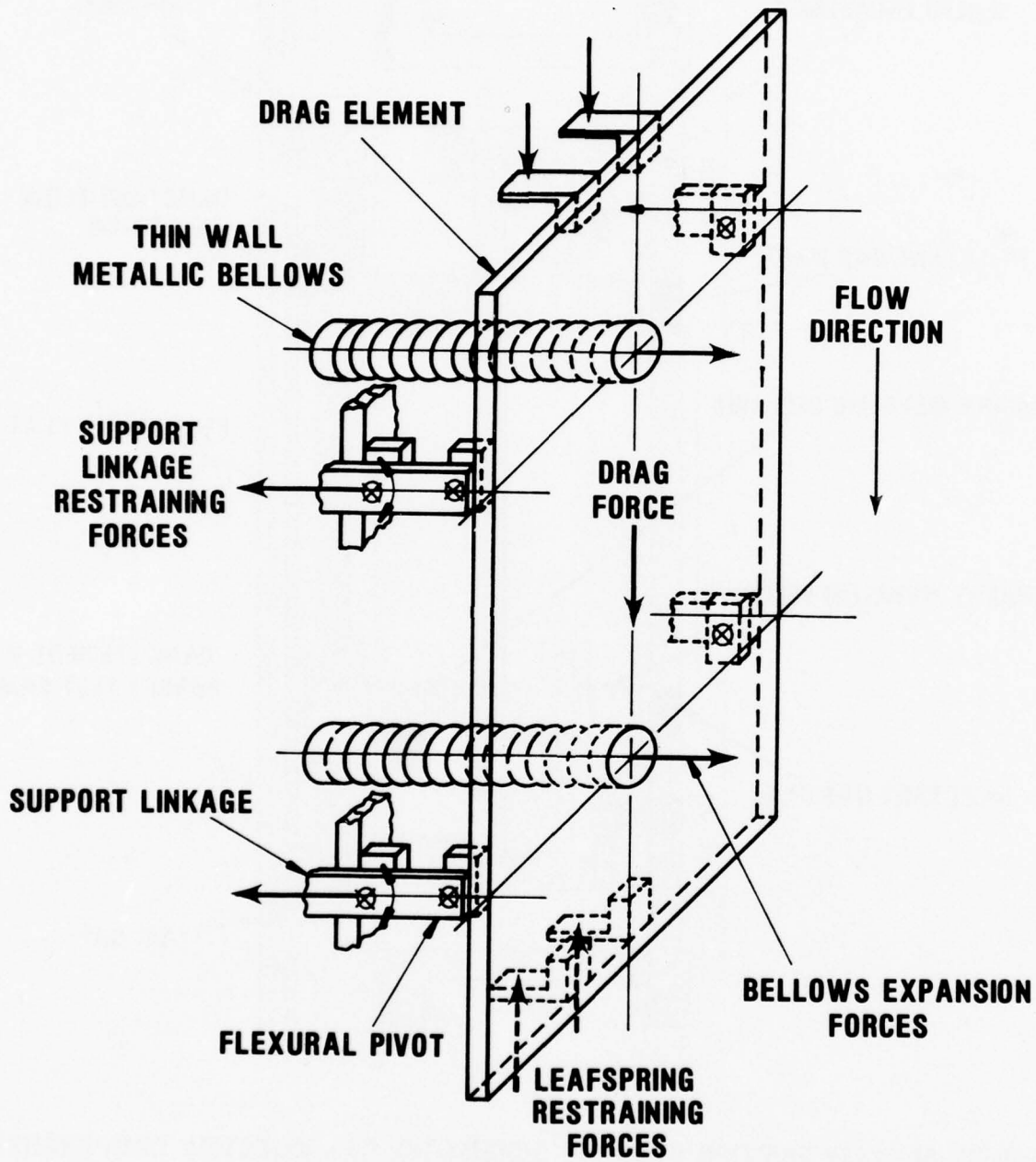

FIGURE 7 DRAG ELEMENT FORCE DIAGRAM

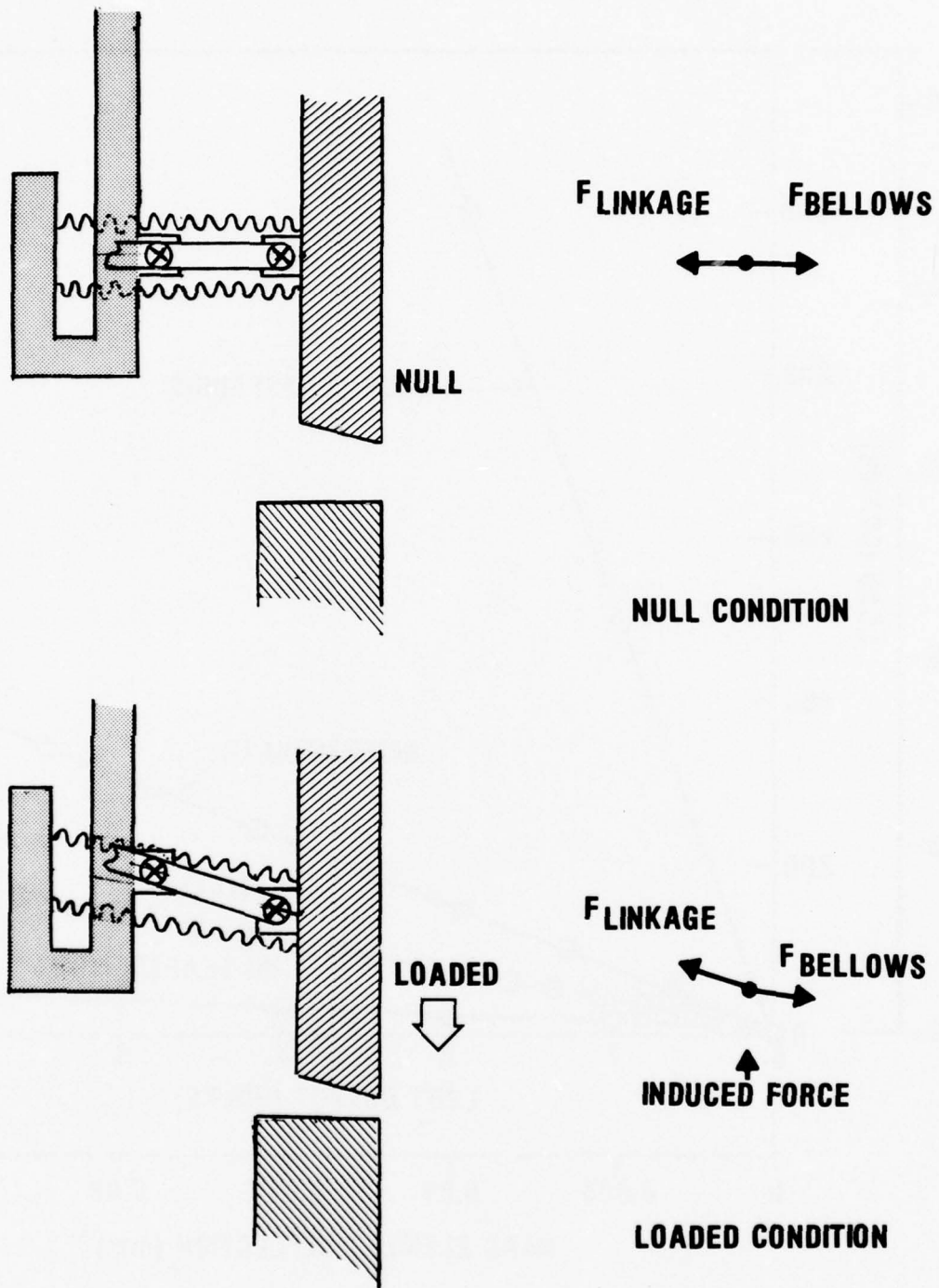

FIGURE 8 DRAG ELEMENT LINKAGE-BELLOWS ALIGNMENT

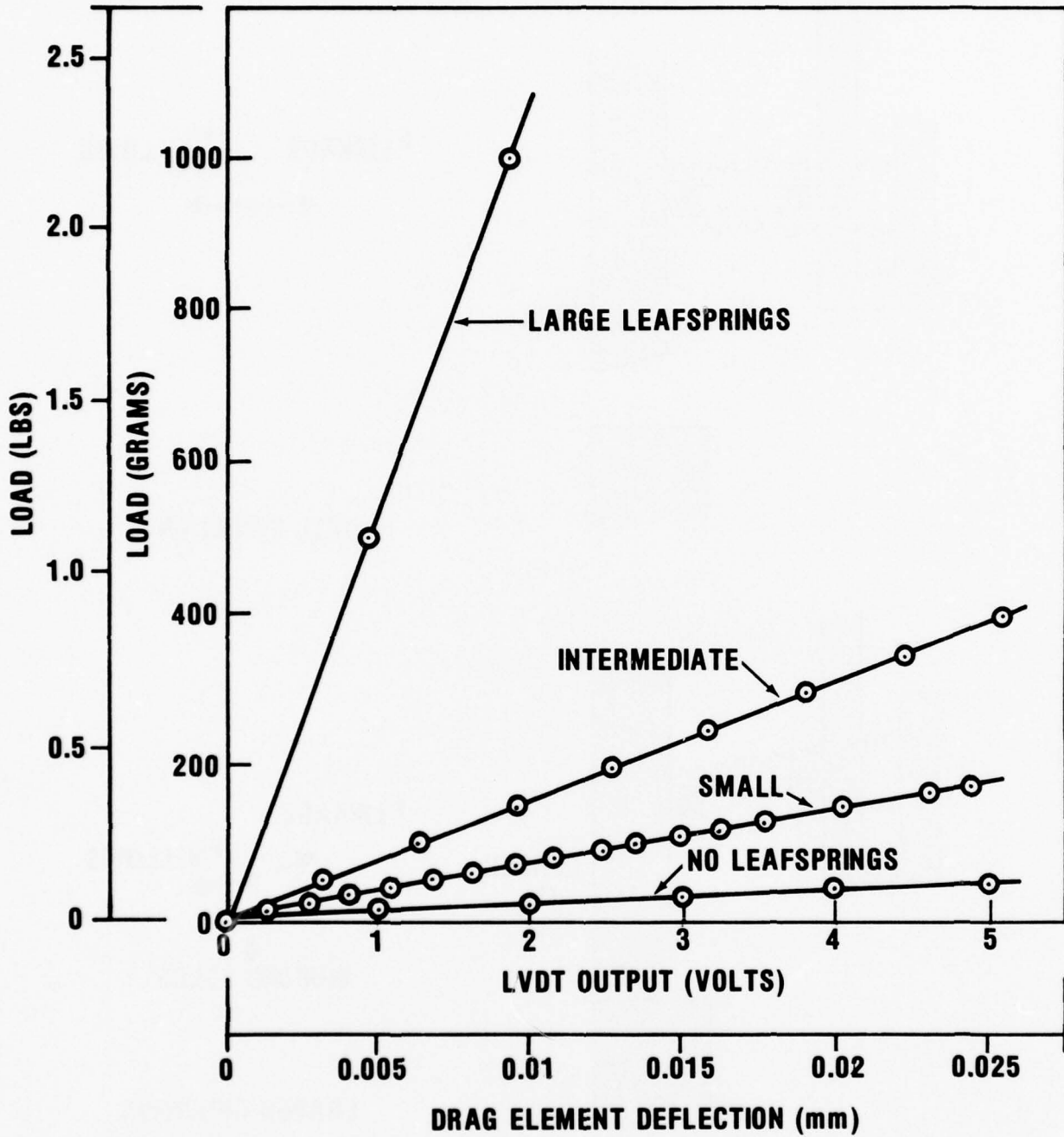

FIGURE 9 SKIN FRICTION BALANCE LOAD CALIBRATIONS

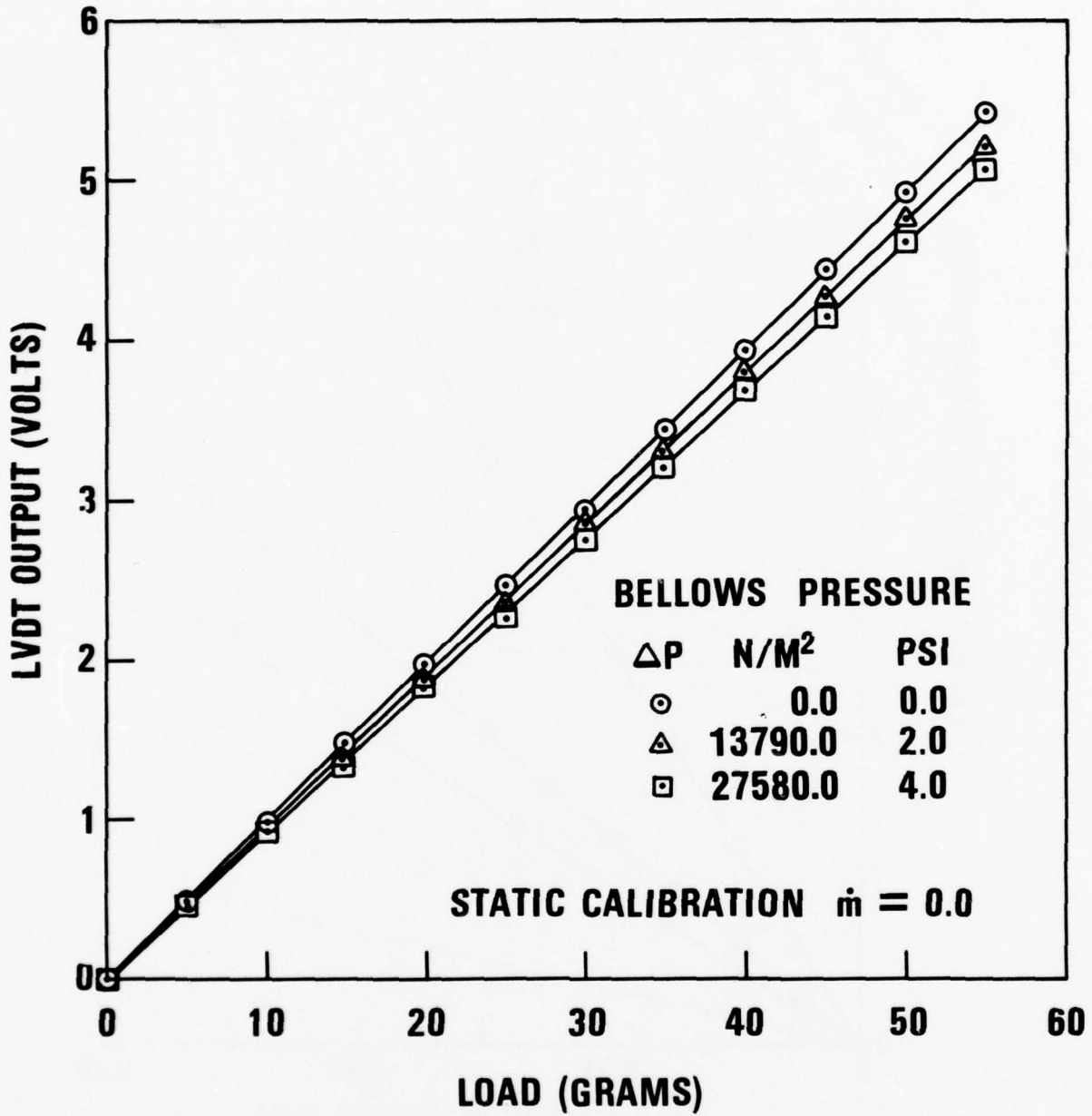

FIGURE 10a LOAD CALIBRATION SHIFT WITH BELLOWS PRESSURIZATION

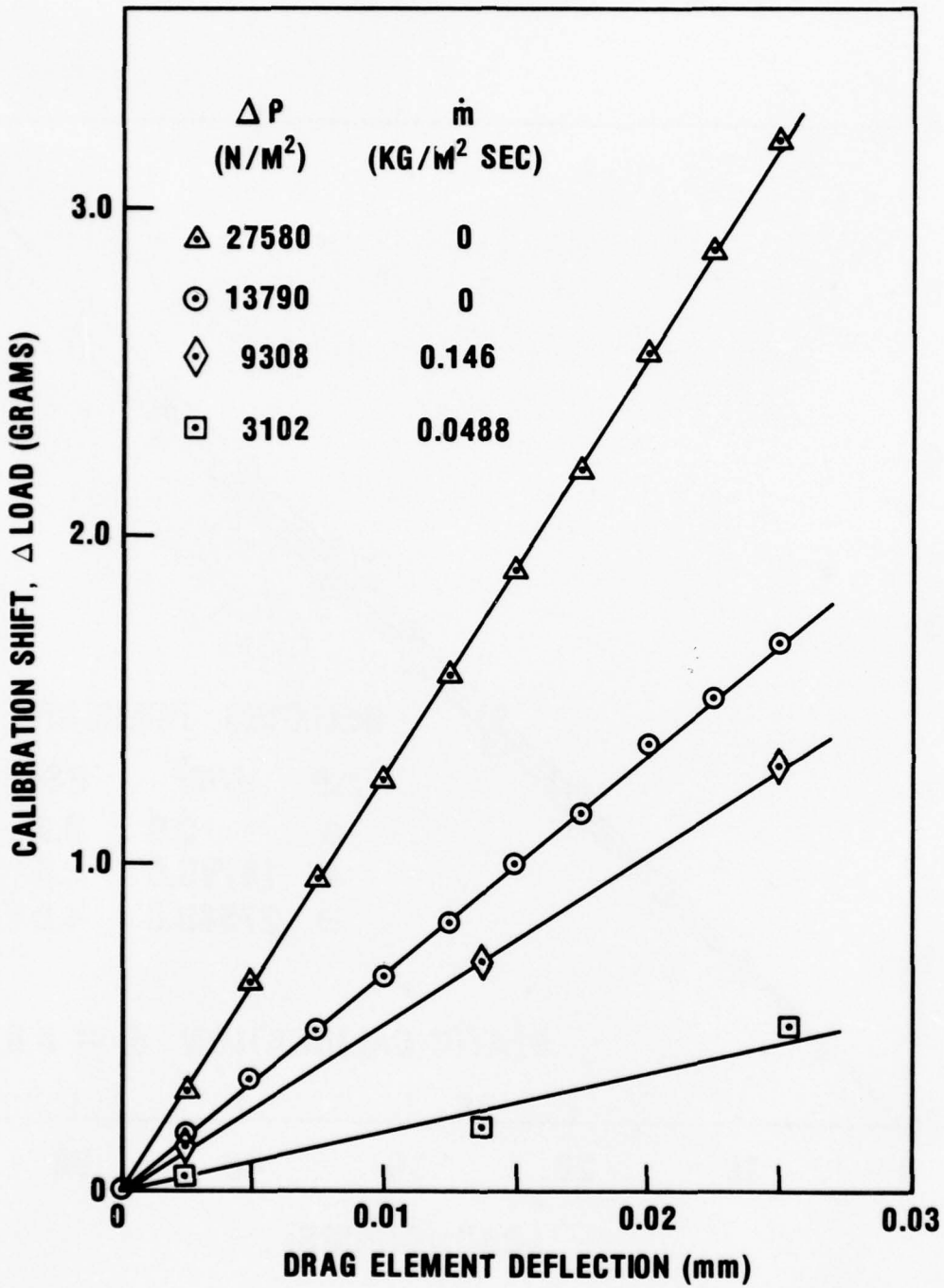

FIGURE 10b LOAD CALIBRATION SHIFT WITH BELLOWS PRESSURIZATION

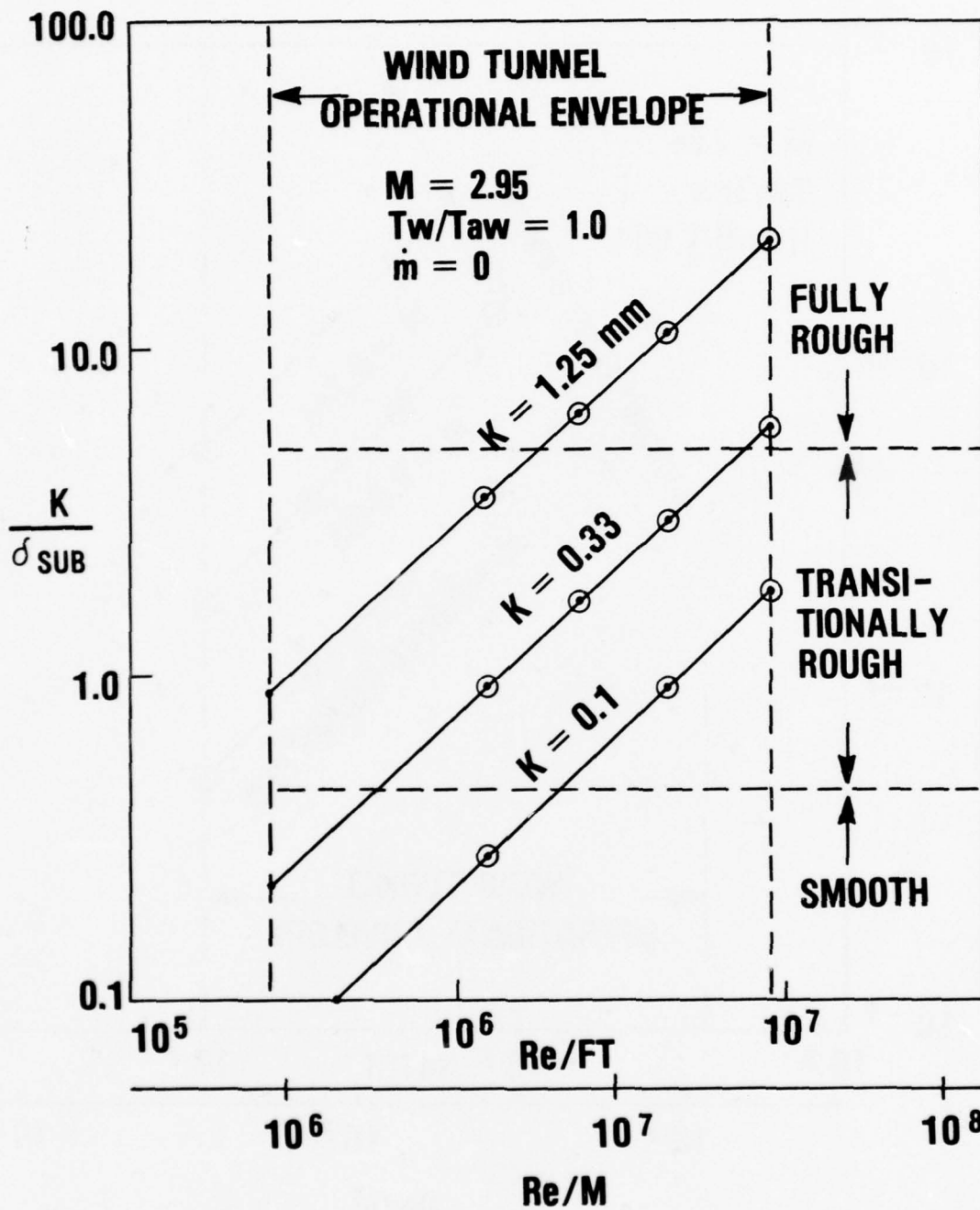

FIGURE 11 ROUGHNESS TESTING MATRIX

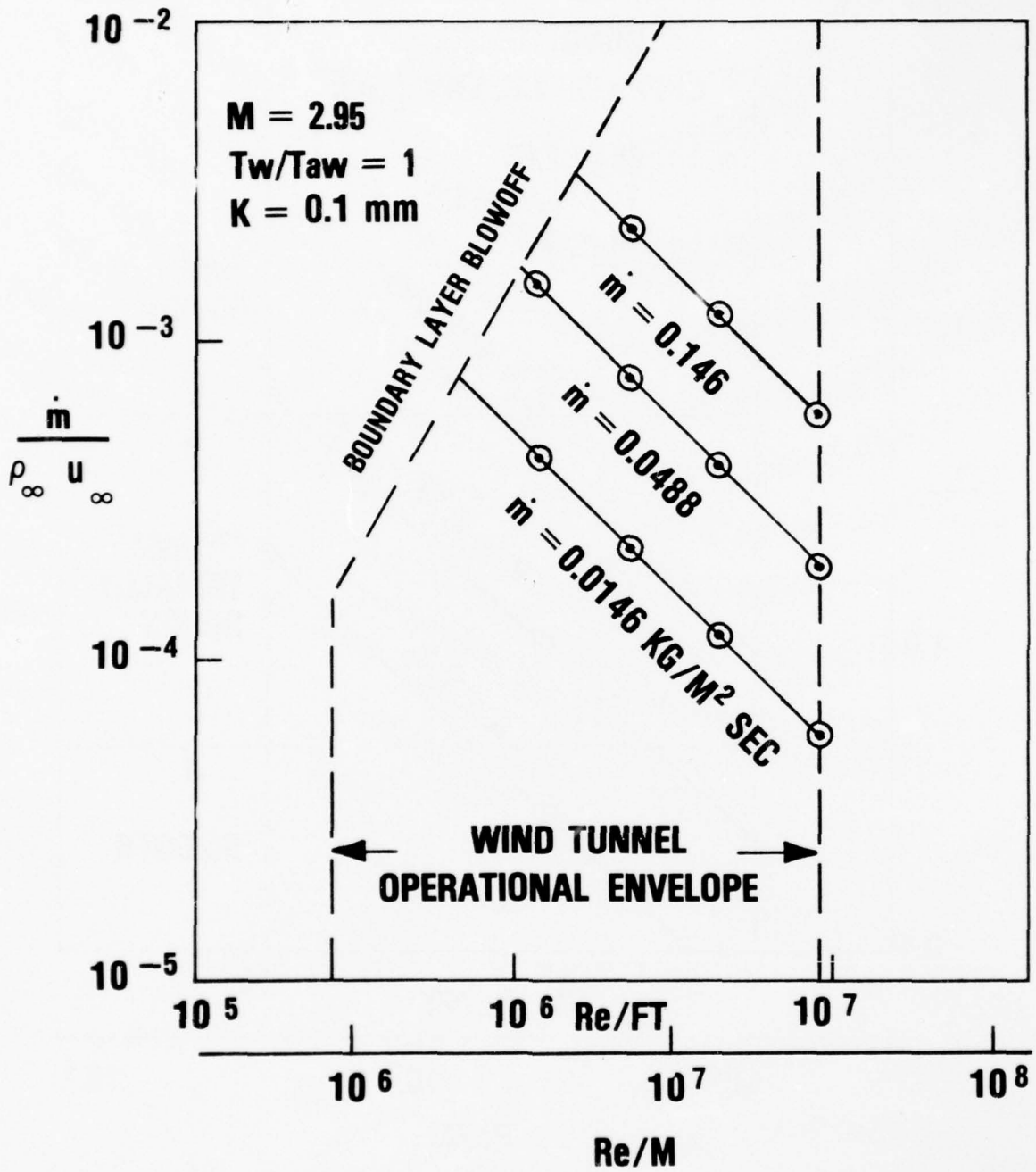

FIGURE 12 BLOWING TESTING MATRIX

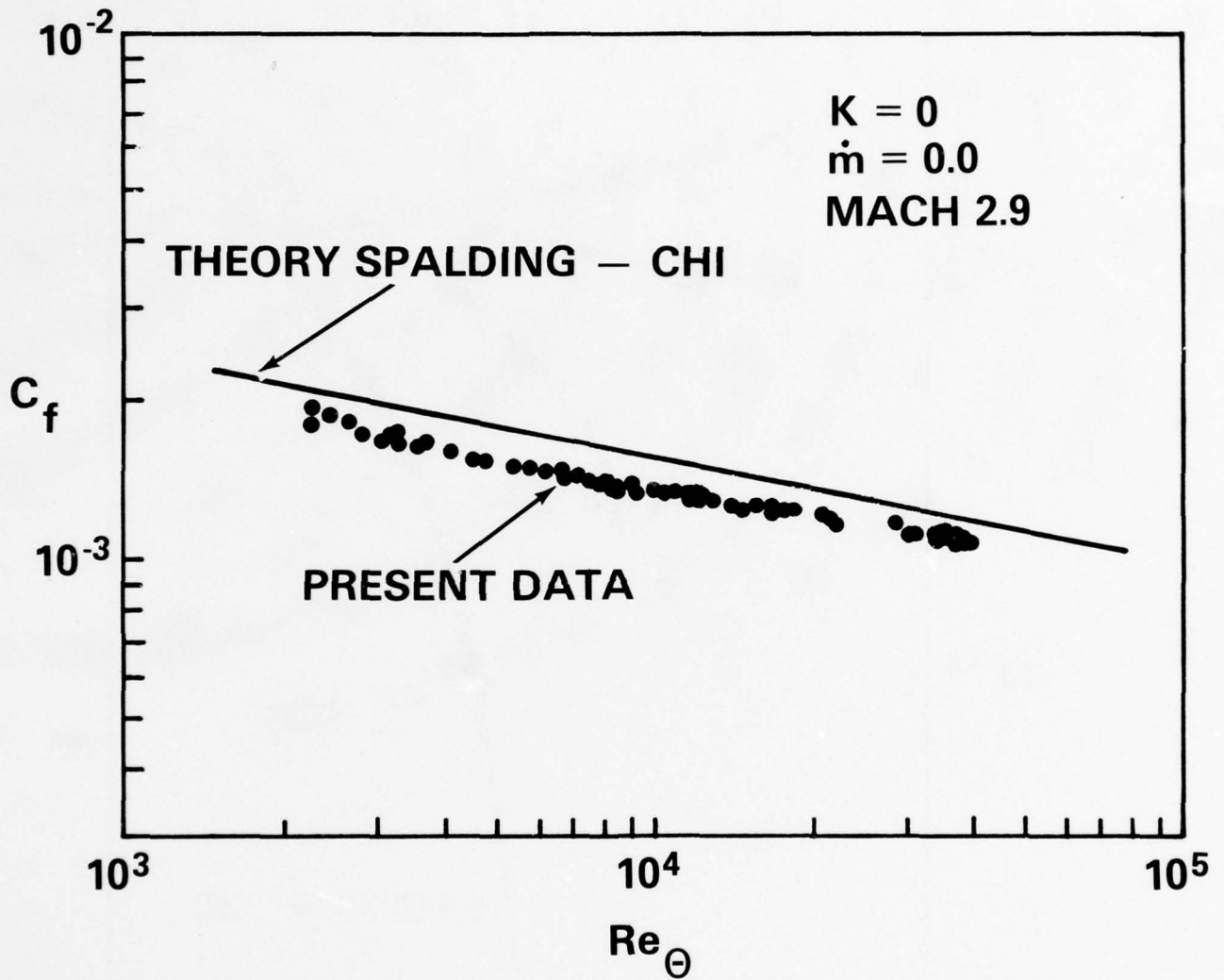

FIGURE 13 SMOOTH-WALL, NON-BLOWING SKIN FRICTION DATA

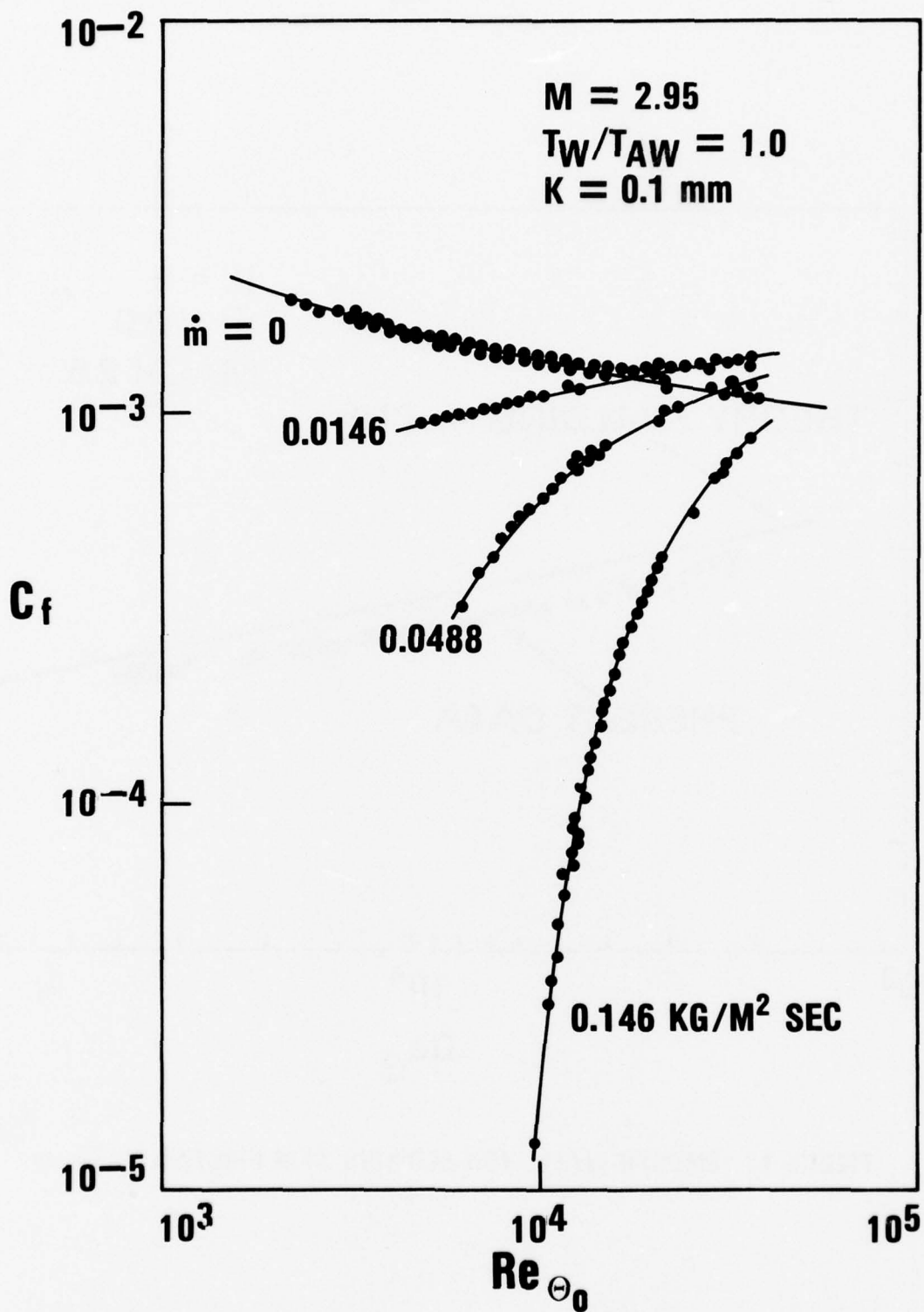
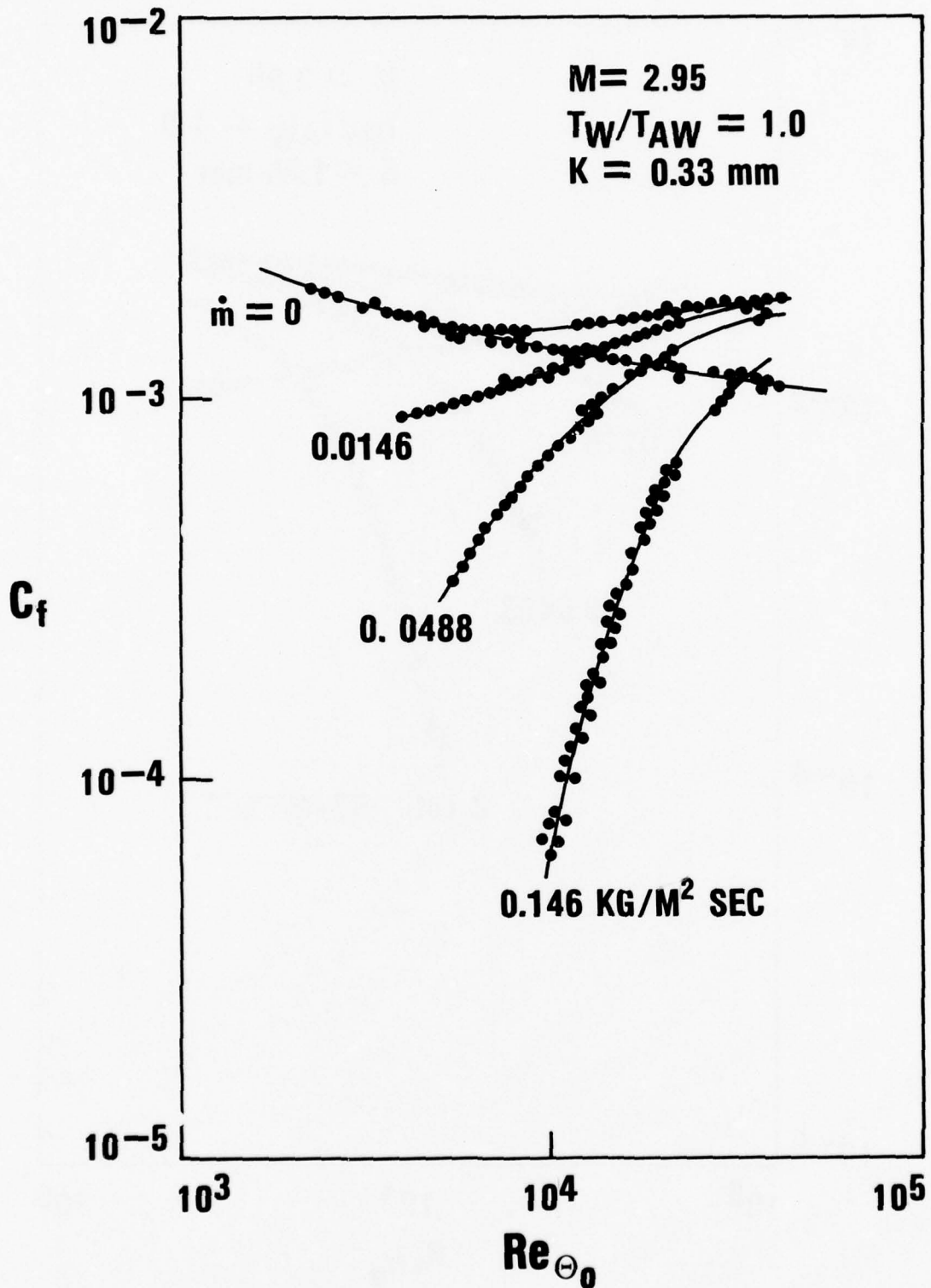
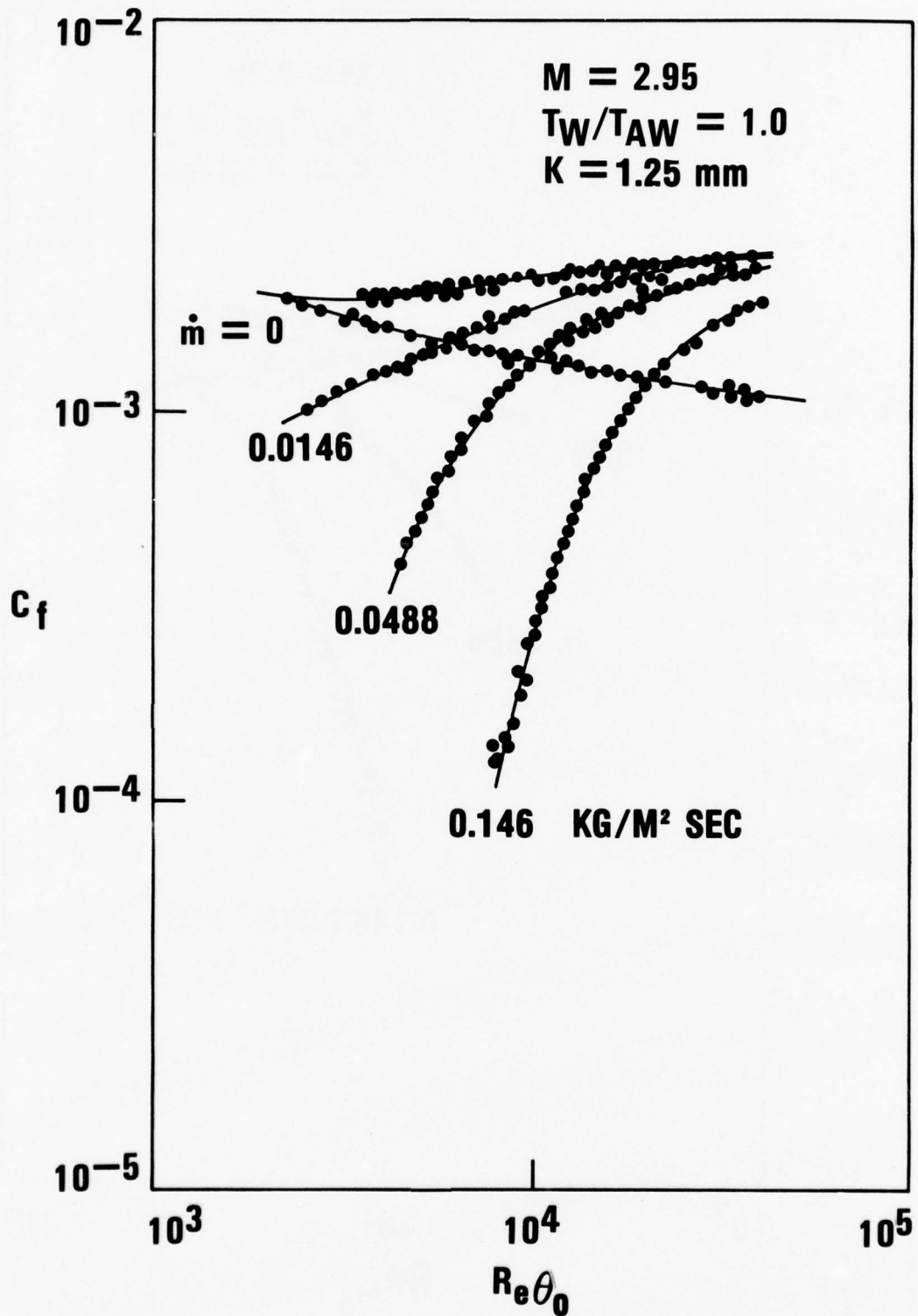
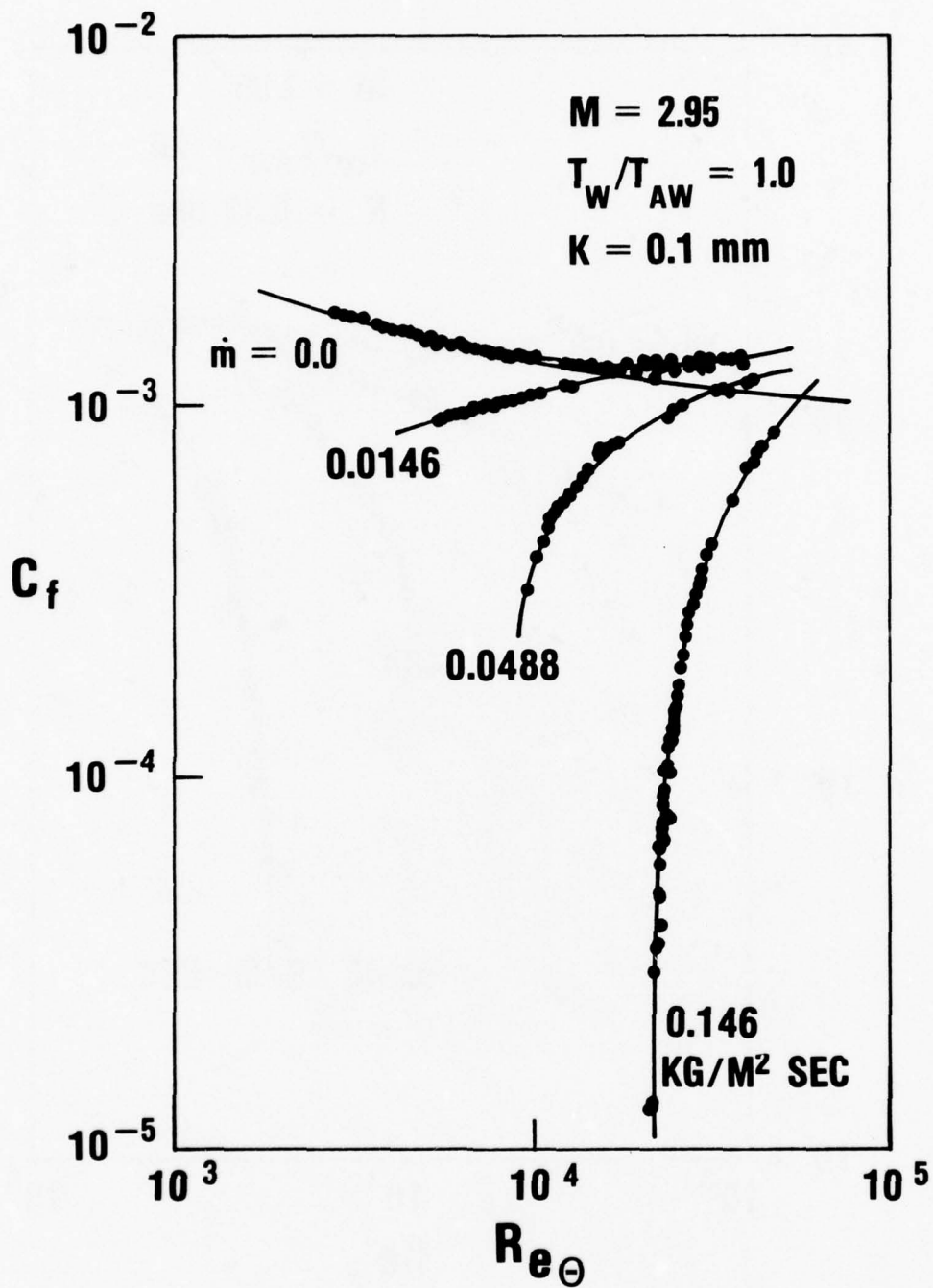

FIGURE 14 SKIN FRICTION DATA WITH BLOWING, $K = 0.1 \text{ mm}$

FIGURE 15 SKIN FRICTION DATA WITH BLOWING, $K = 0.33 \text{ mm}$

FIGURE 16 SKIN FRICTION DATA WITH BLOWING, $K = 1.25 \text{ mm}$

FIGURE 17 SKIN FRICTION DATA WITH BLOWING, $K=0.1 \text{ mm}$

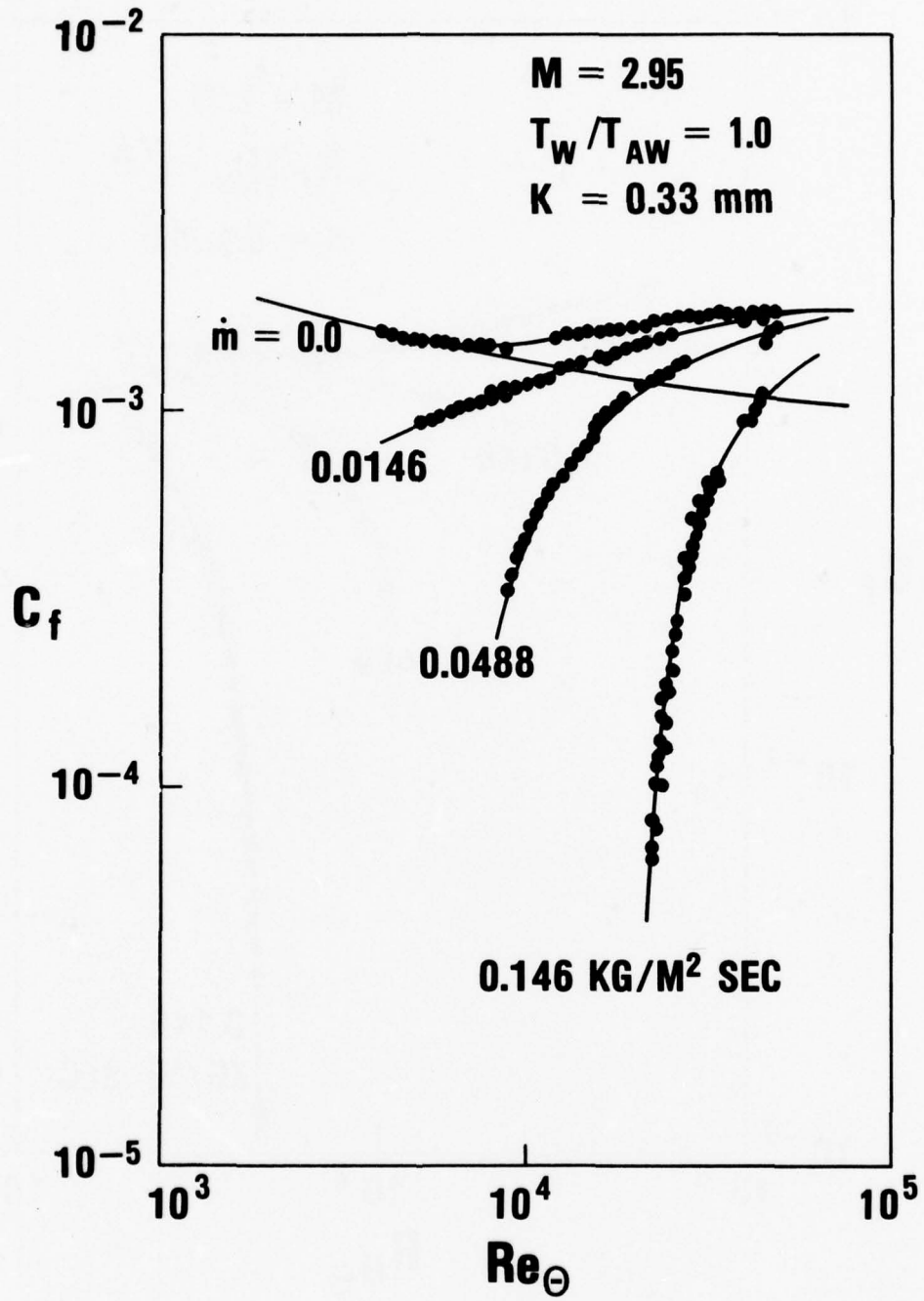

FIGURE 18 SKIN FRICTION DATA WITH BLOWING, $K = 0.33 \text{ mm}$

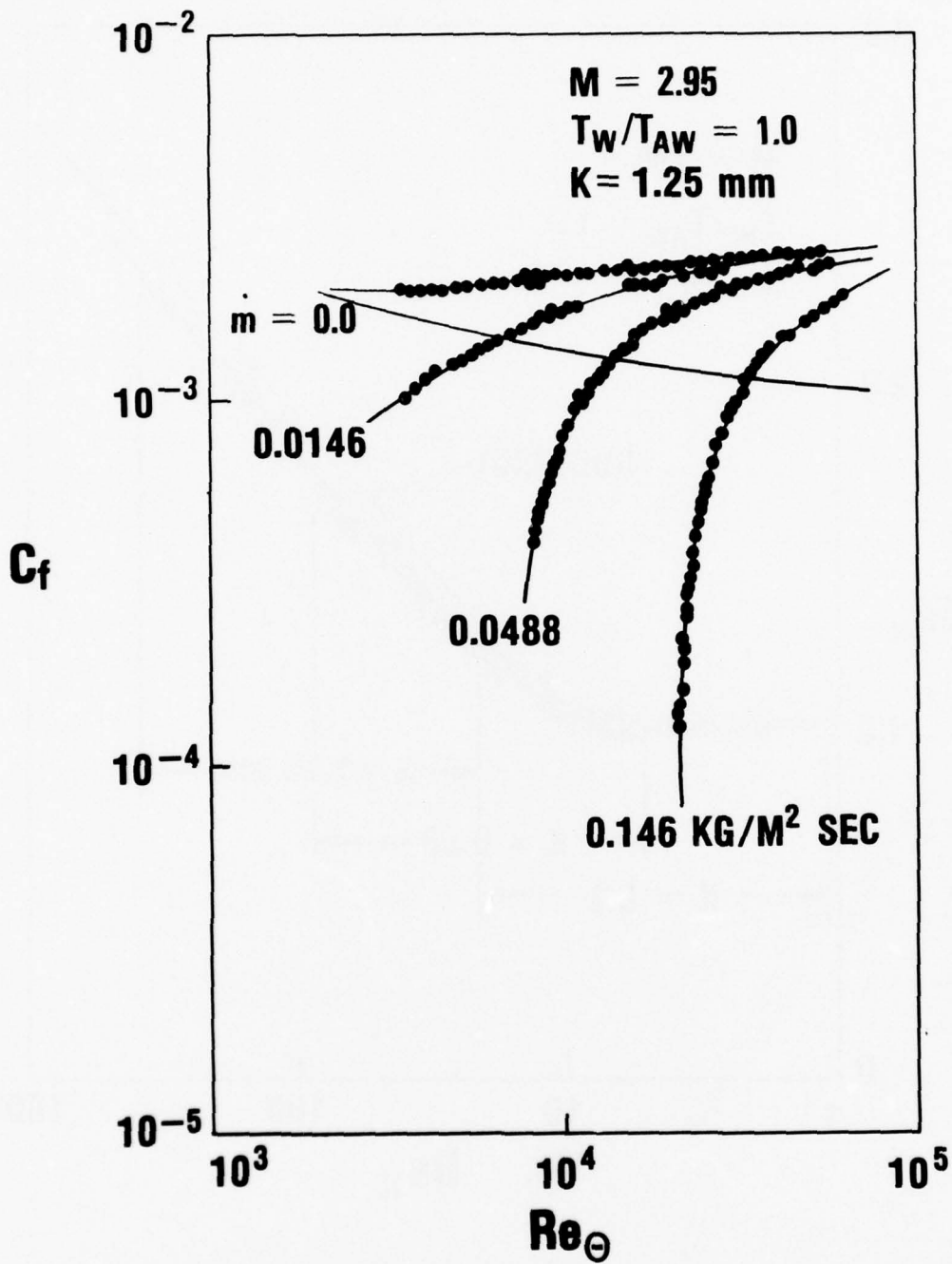

FIGURE 19 SKIN FRICTION DATA WITH BLOWING $K = 1.25 \text{ mm}$

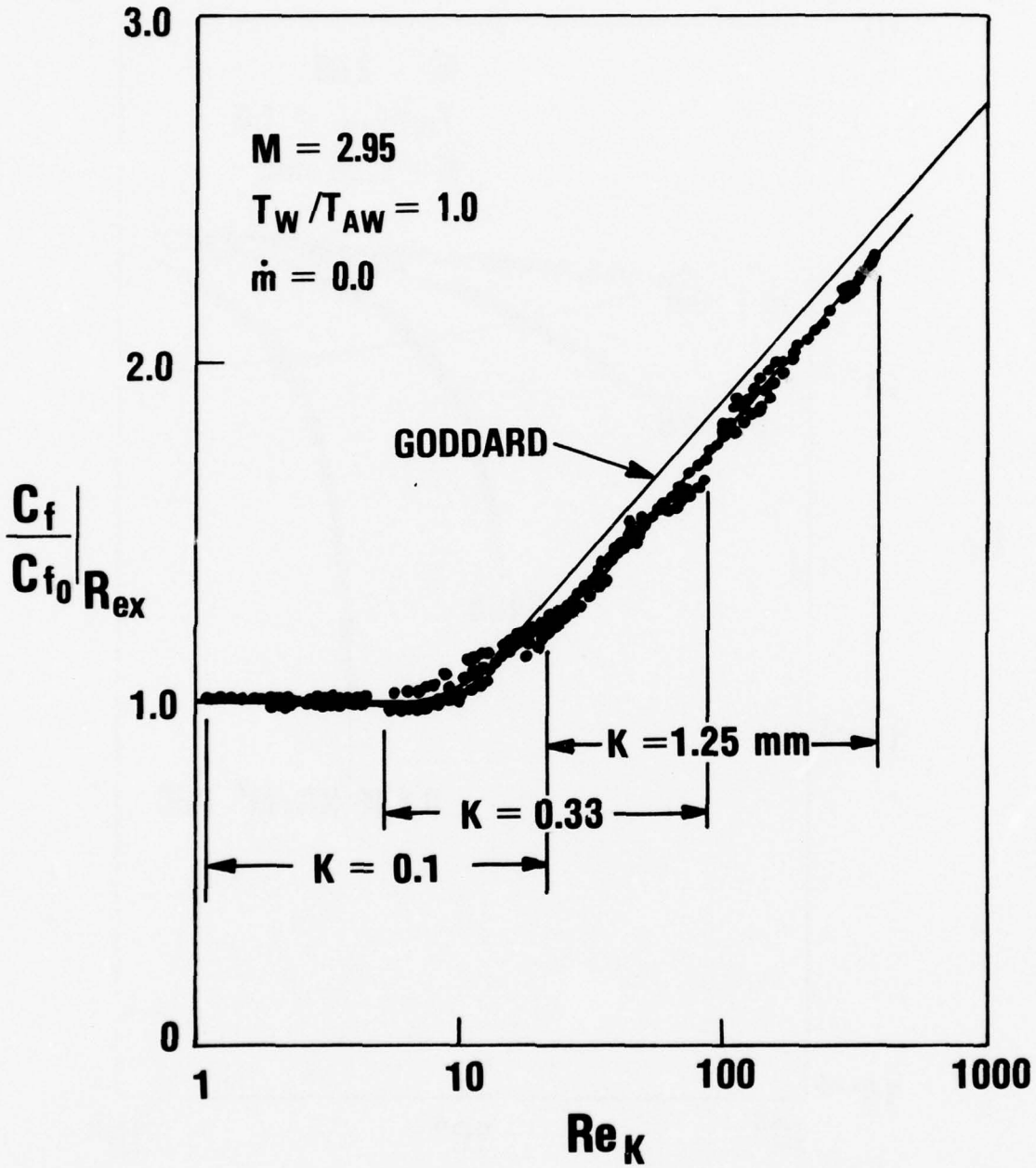

FIGURE 20 ROUGHNESS EFFECTS ON SKIN FRICTION

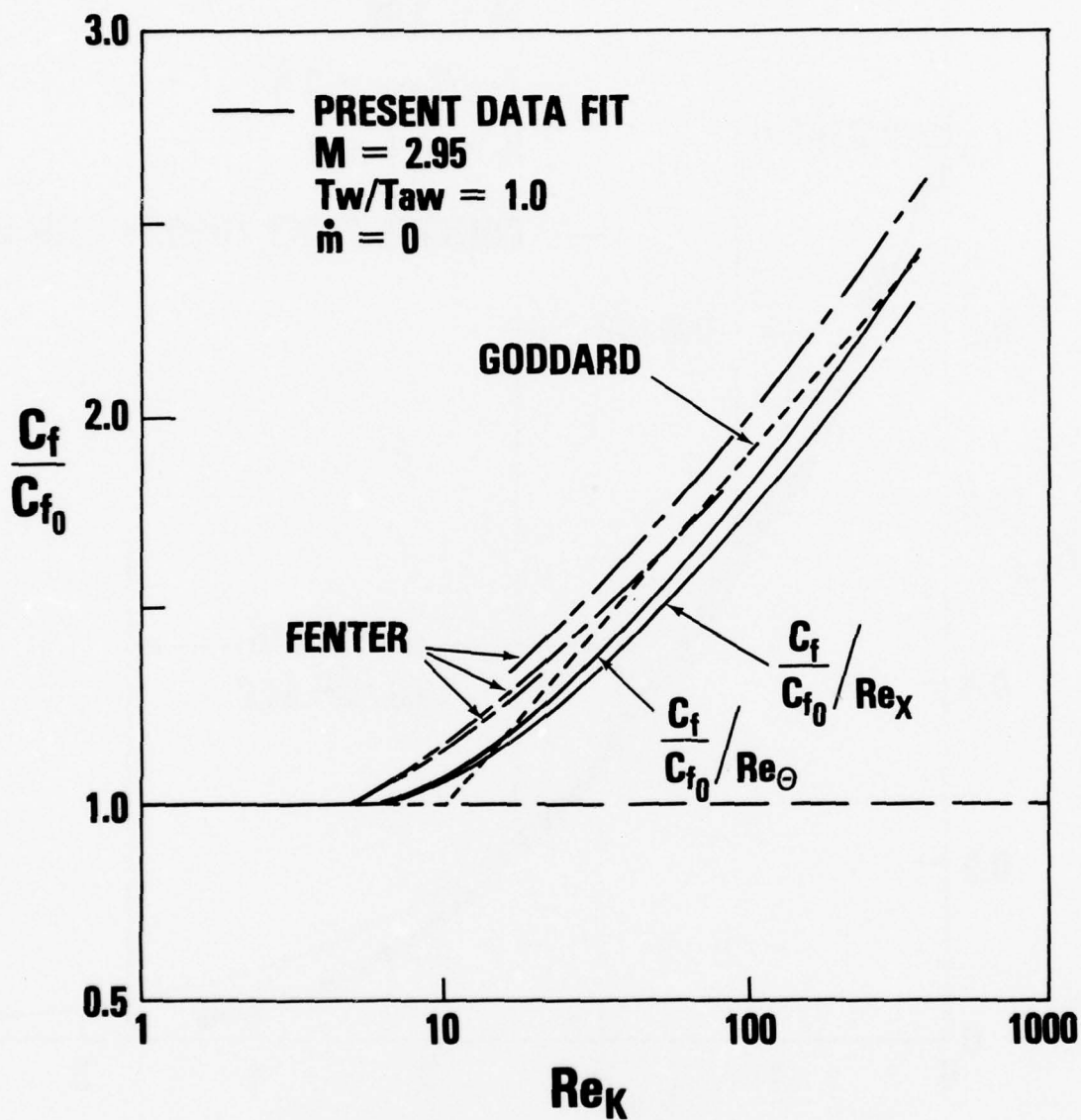

FIGURE 21 ROUGHNESS EFFECTS ON SKIN FRICTION, A COMPARISON WITH THEORY

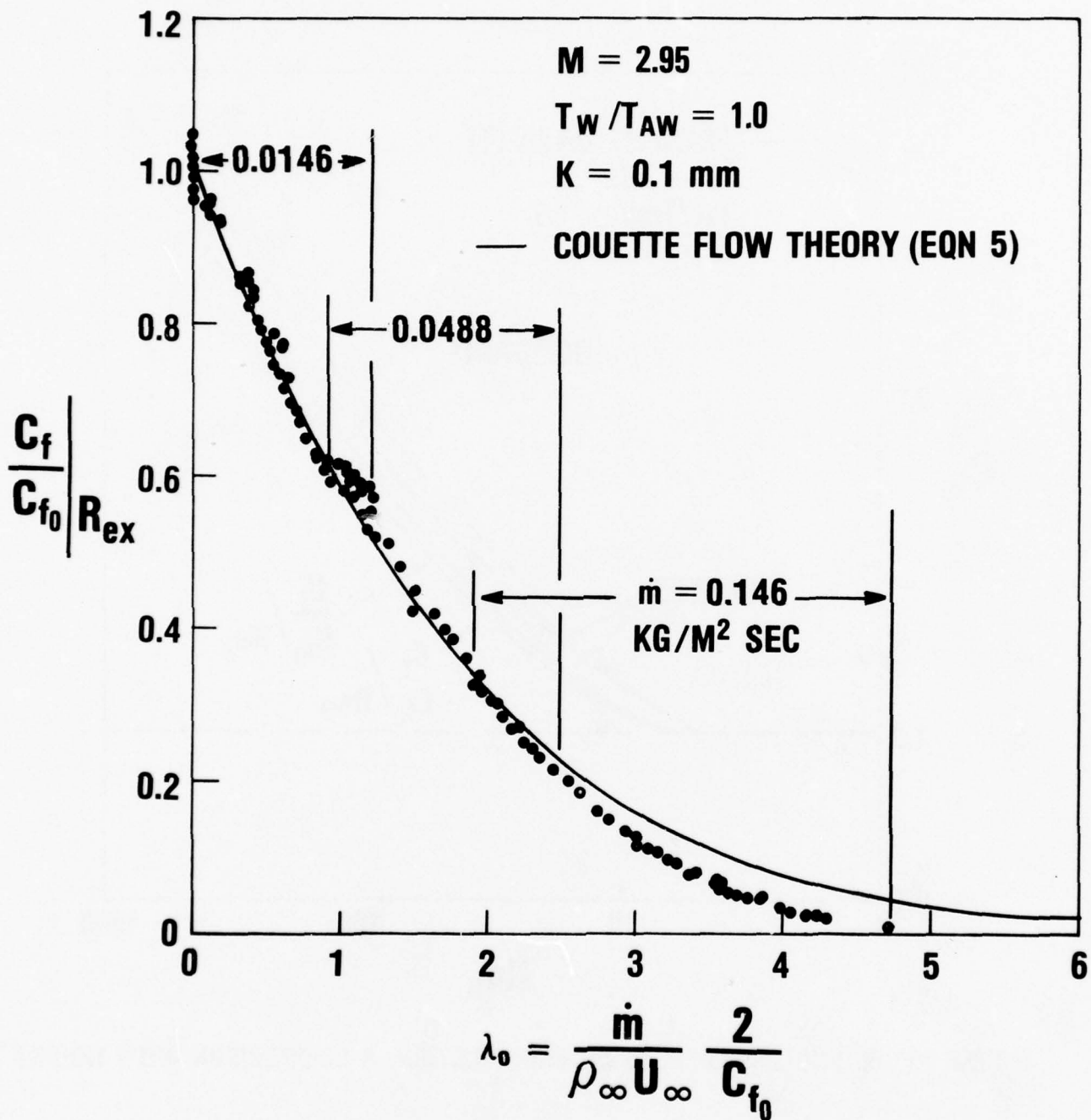

FIGURE 22 BLOWING EFFECTS ON SKIN FRICTION

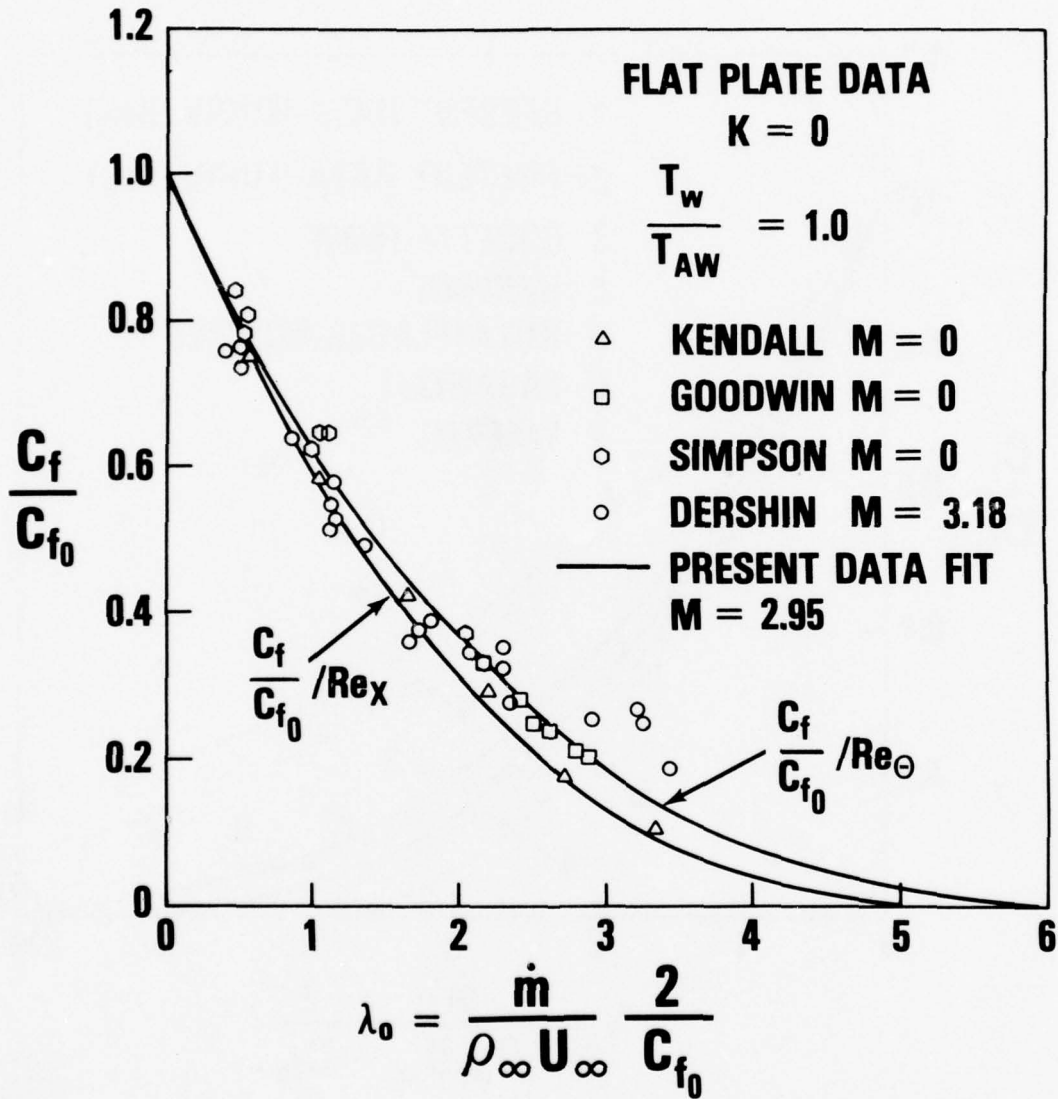

FIGURE 23 BLOWING EFFECTS ON SKIN FRICTION, A COMPARISON WITH OTHER DATA

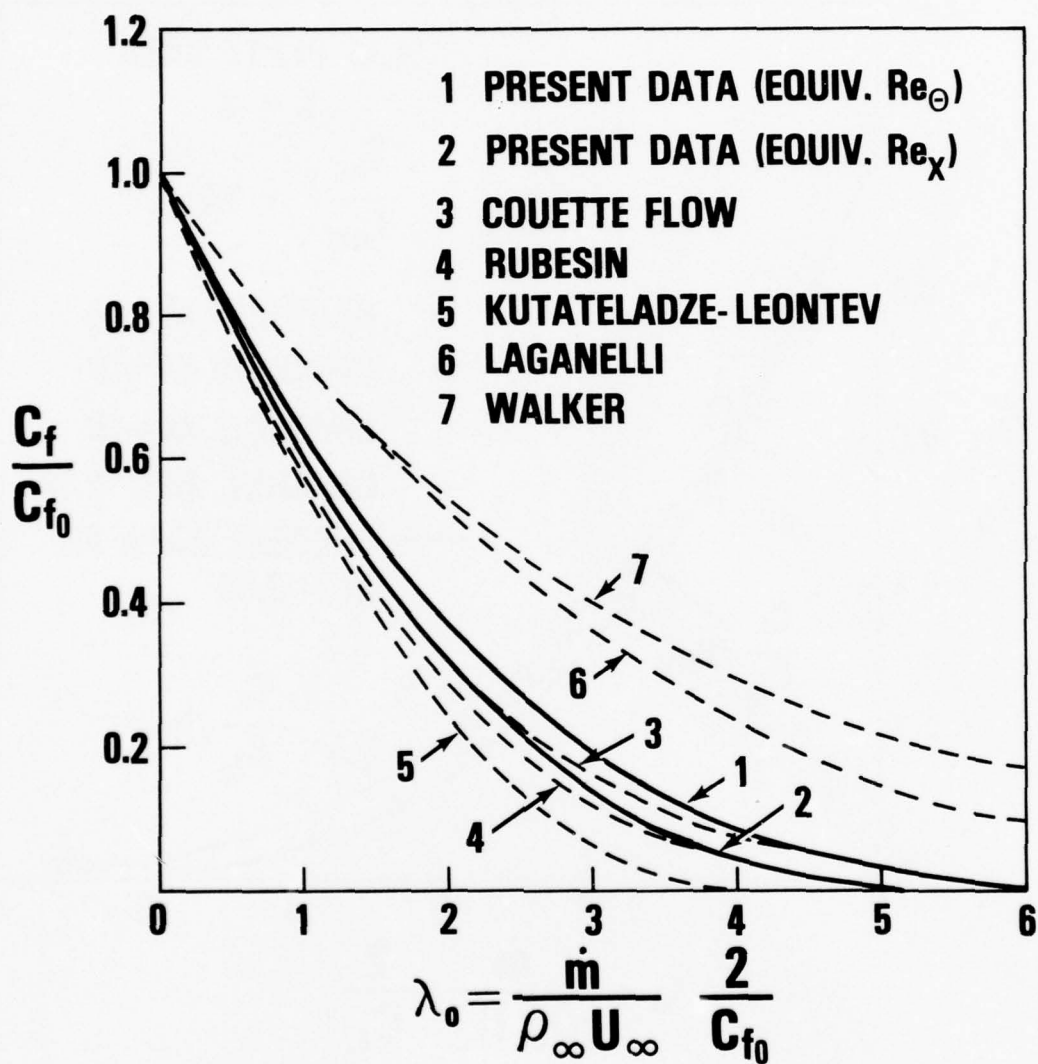

FIGURE 24 BLOWING EFFECTS ON SKIN FRICTION, A COMPARISON WITH THEORY

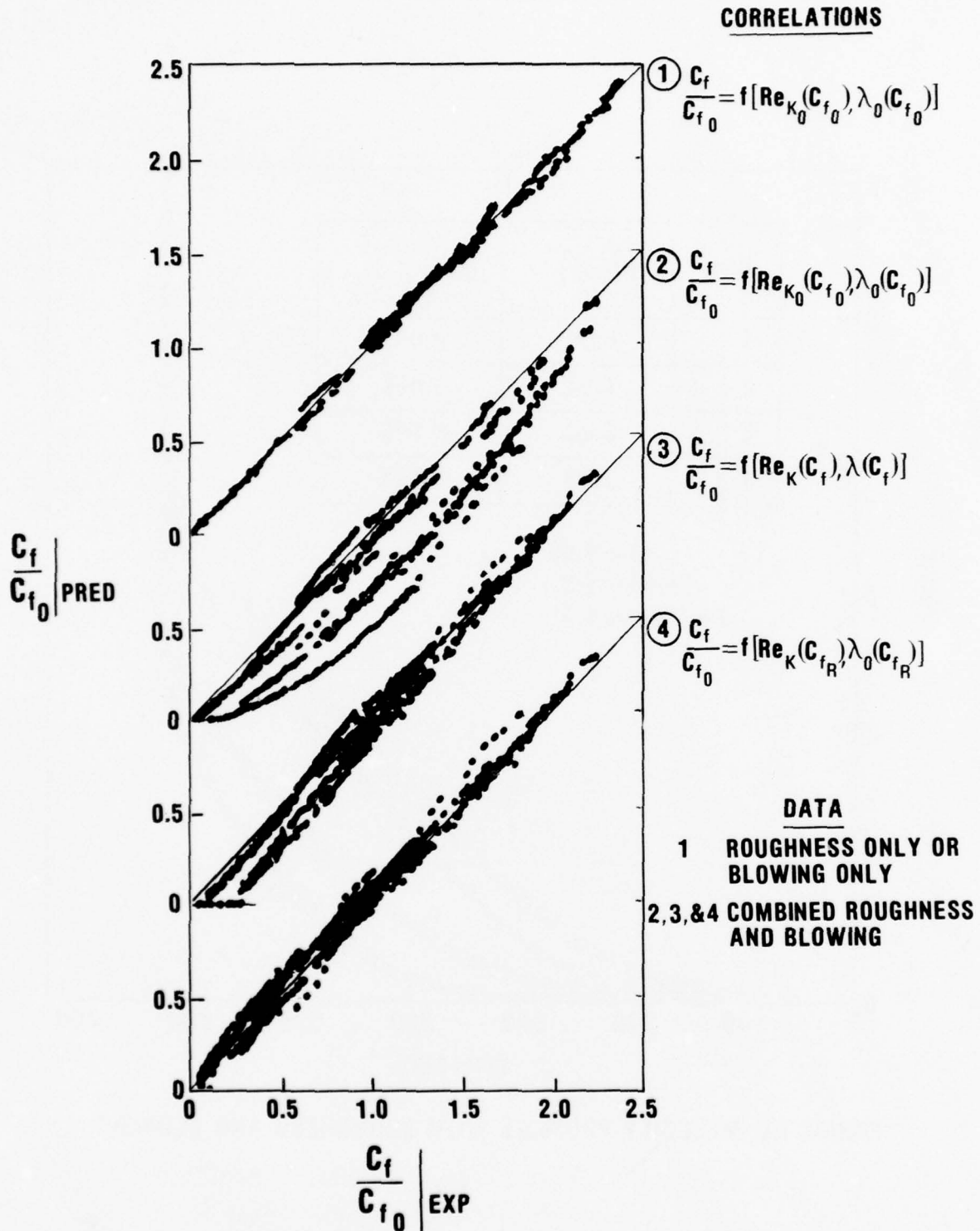

FIGURE 25 A COMPARISON OF PREDICTED AND MEASURED SKIN FRICTION USING INDEPENDENT CORRELATION SCHEMES

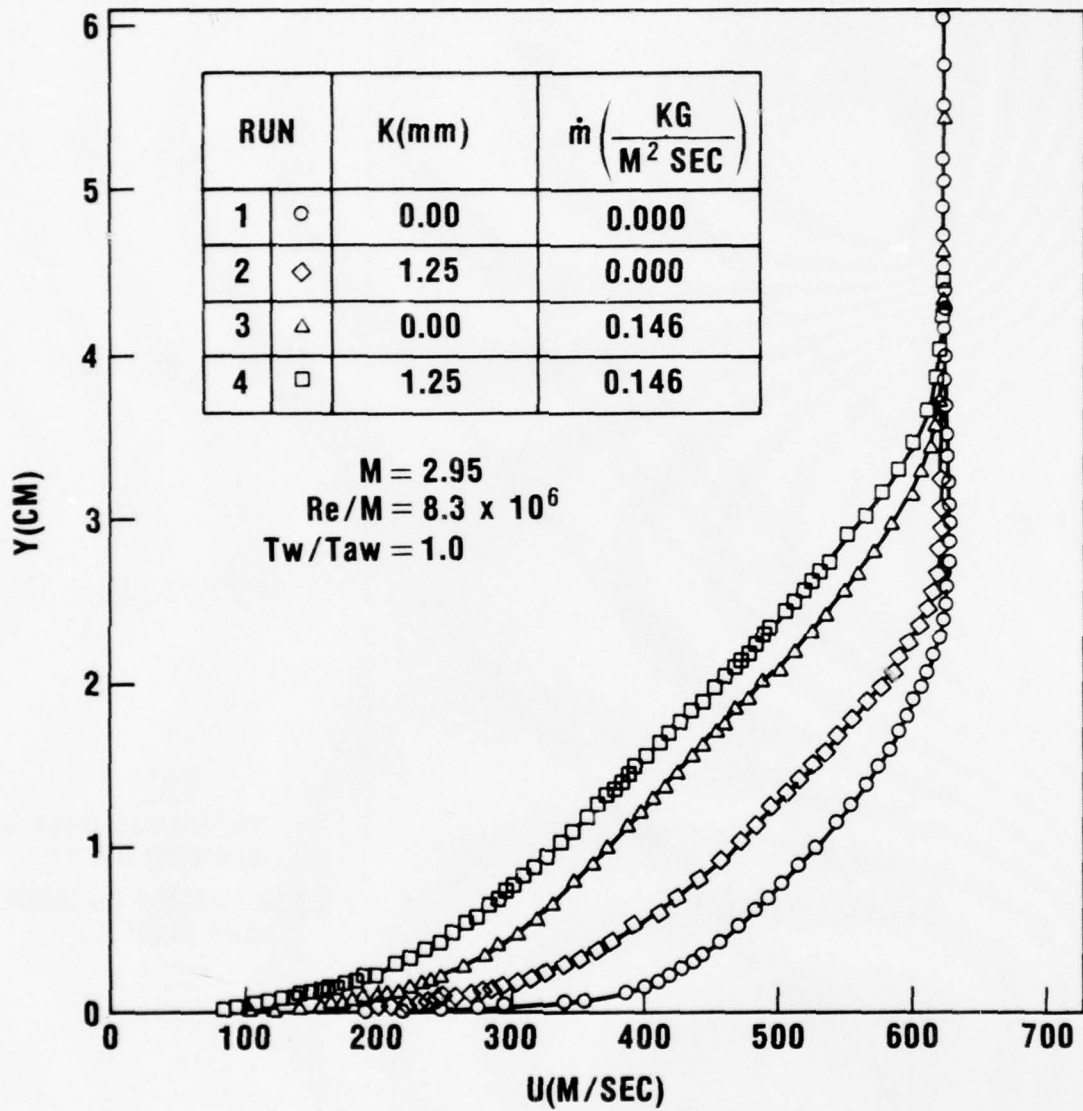

FIGURE 26 VELOCITY PROFILES WITH ROUGHNESS AND BLOWING

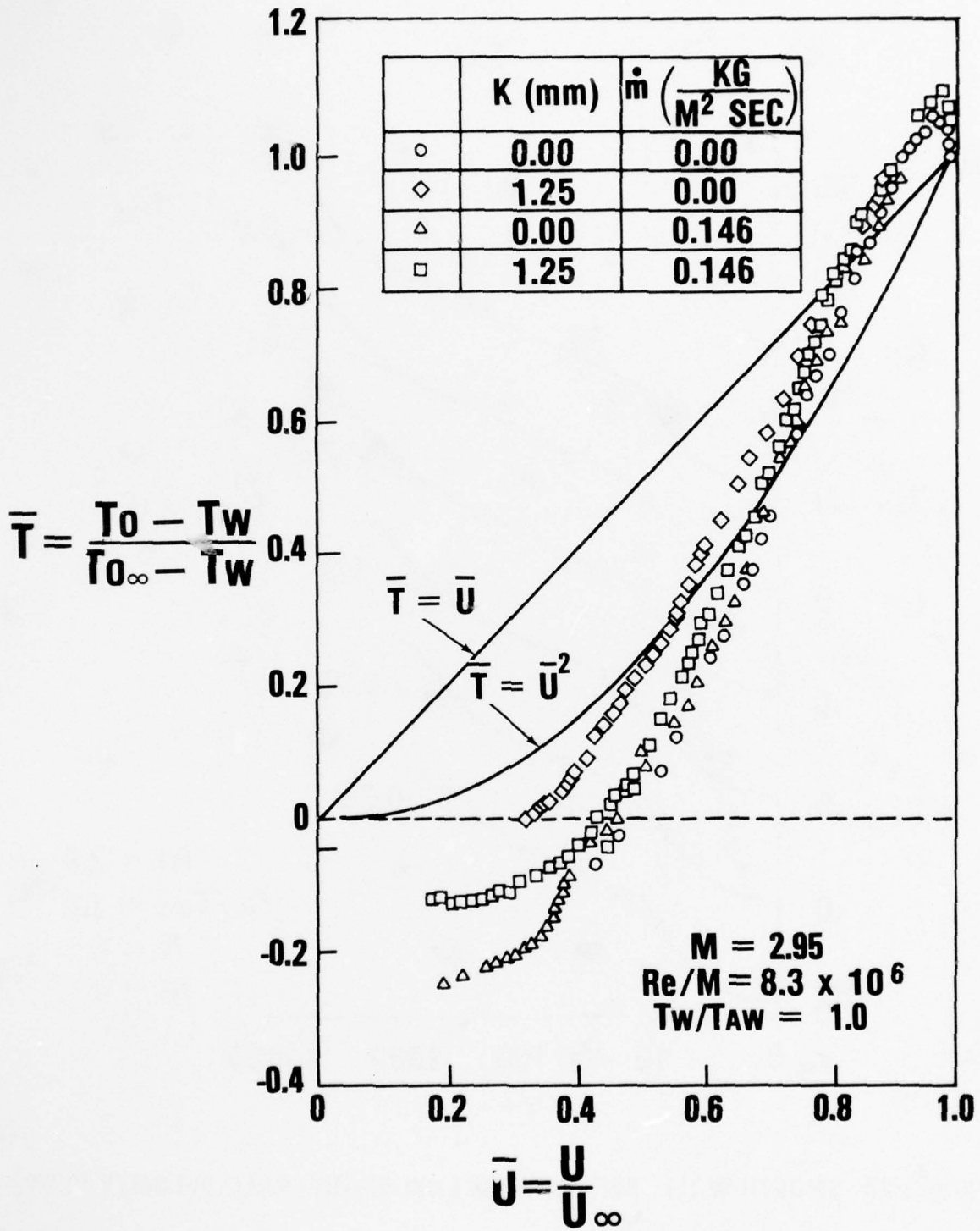

FIGURE 27 TEMPERATURE-VELOCITY CORRELATION PLOTS WITH ROUGHNESS AND BLOWING

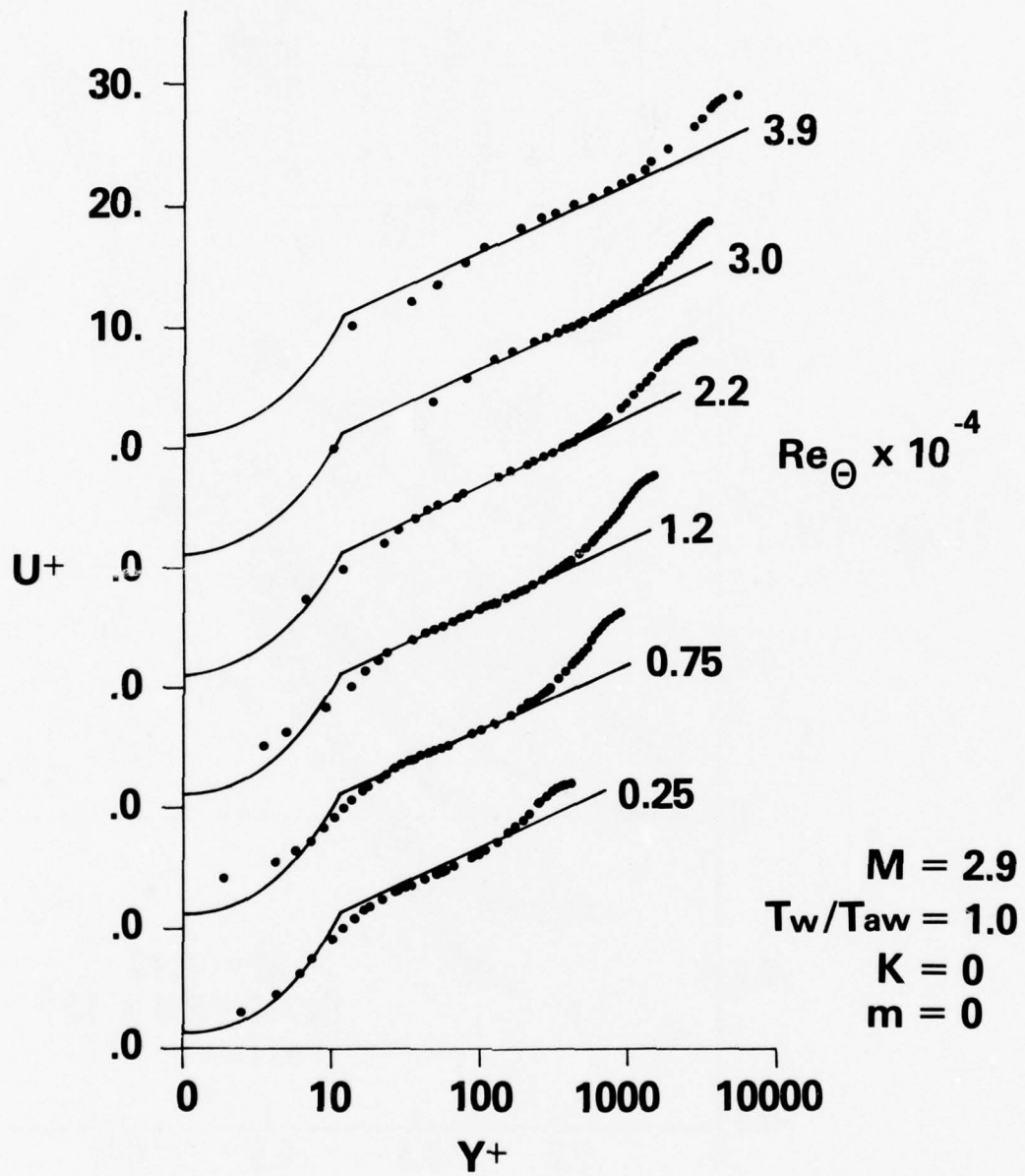

FIGURE 28 SMOOTH-WALL, NON-BLOWING LAW-OF-THE-WALL VELOCITY PLOTS

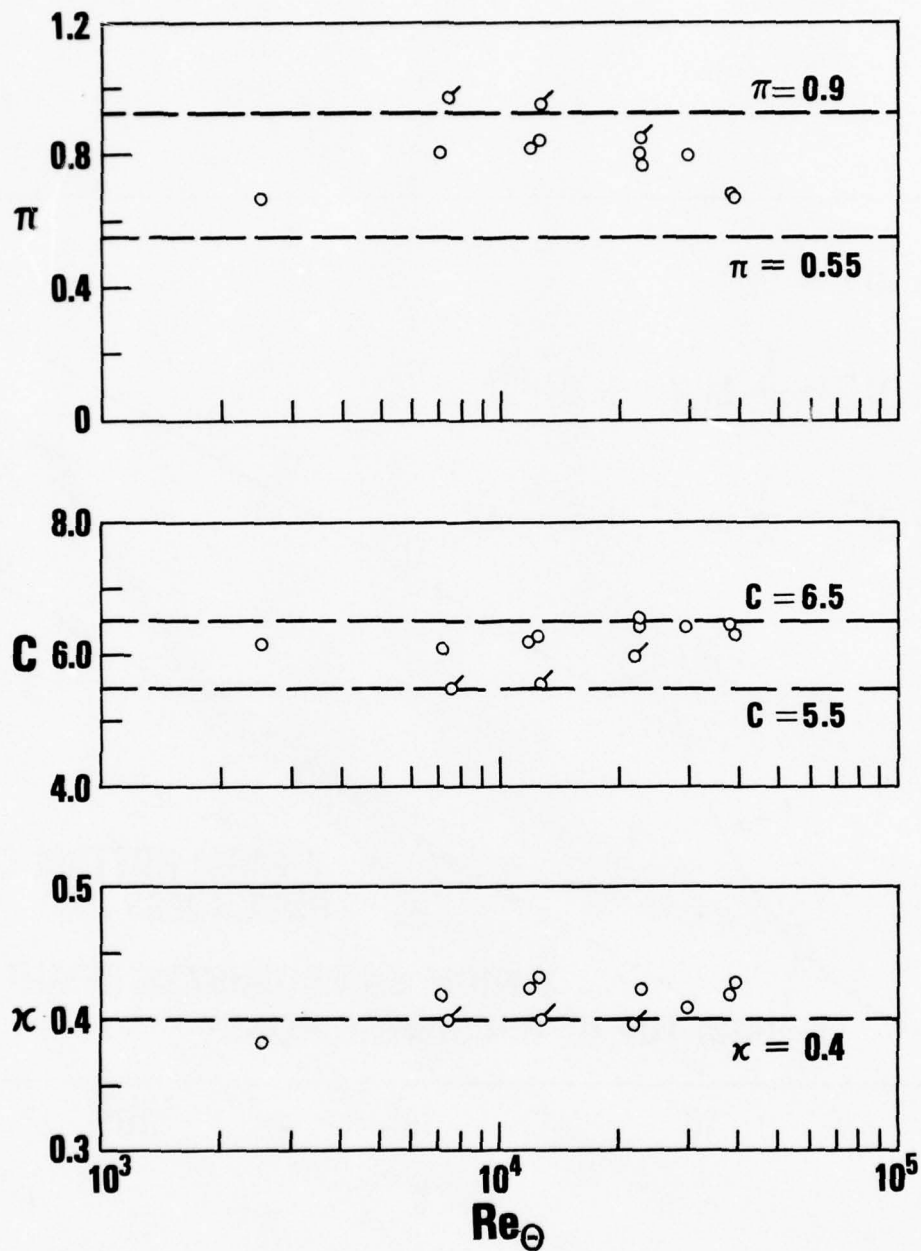

FIGURE 29 SMOOTH-WALL, NON-BLOWING LAW-OF-THE-WALL PROFILE CONSTANTS

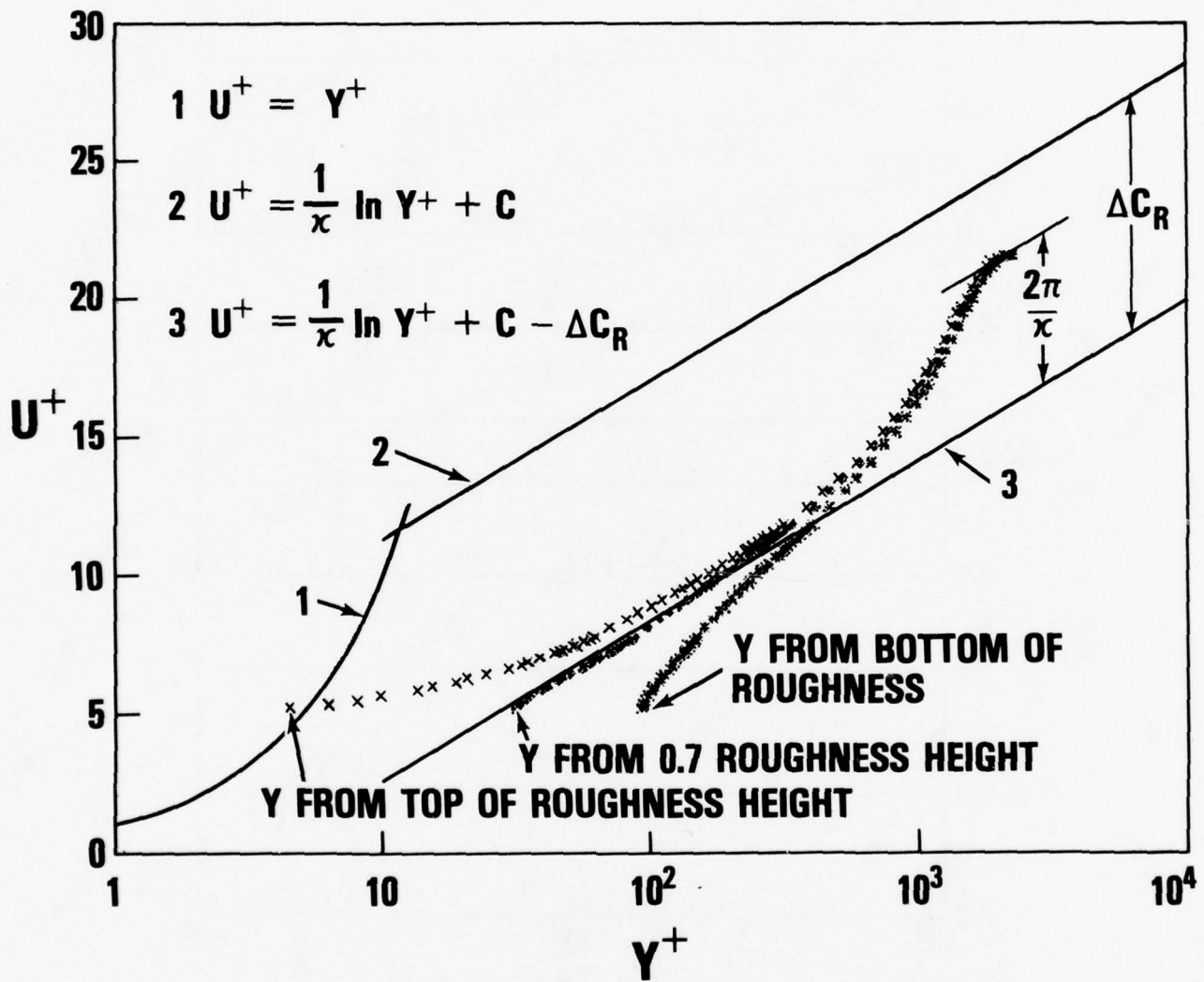

FIGURE 30 TYPICAL LAW-OF-THE-WALL PLOT WITH ROUGHNESS

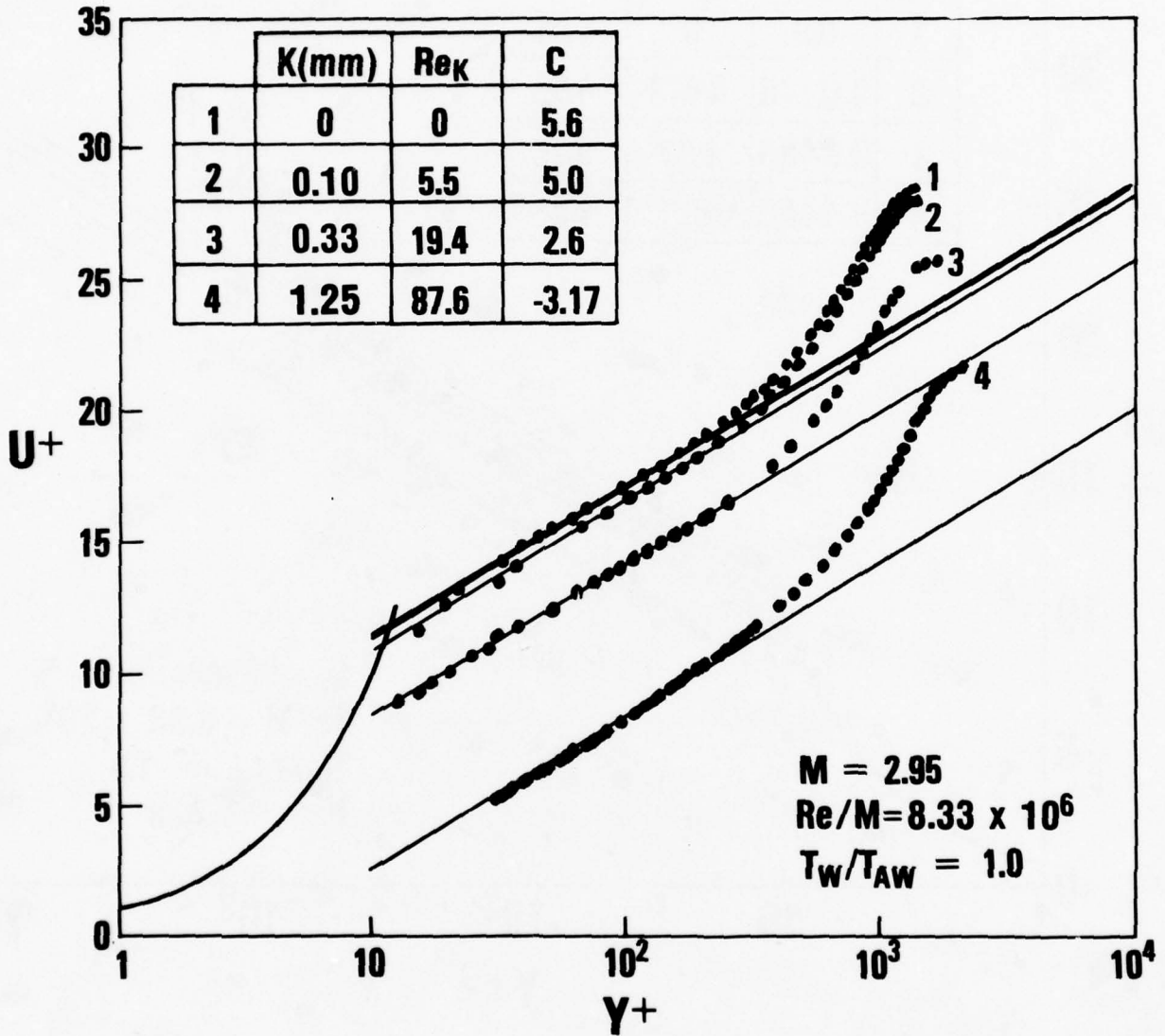

FIGURE 31 LAW-OF-THE-WALL VELOCITY PLOTS WITH ROUGHNESS

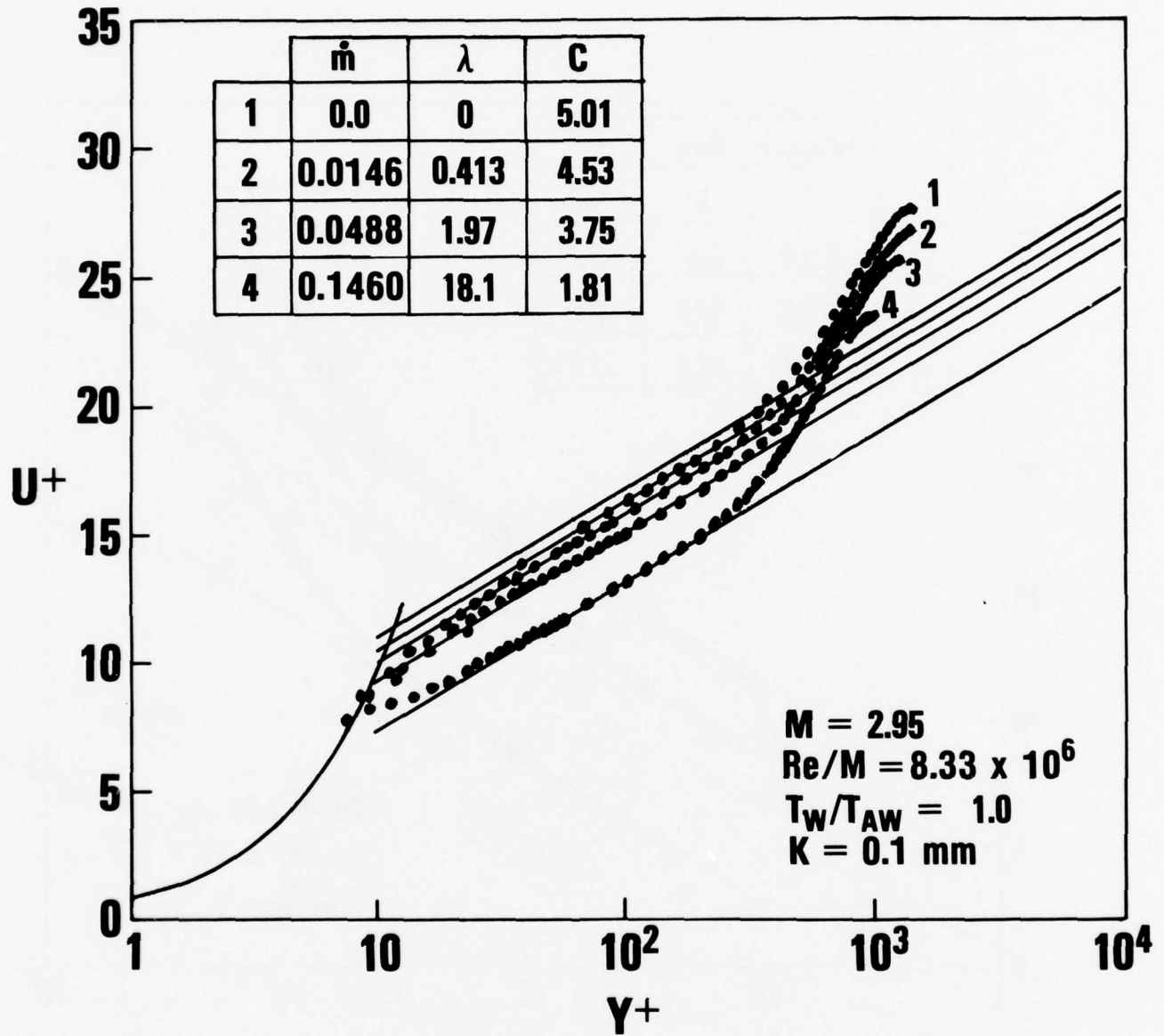

FIGURE 32 LAW-OF-THE-WALL VELOCITY PLOTS WITH BLOWING

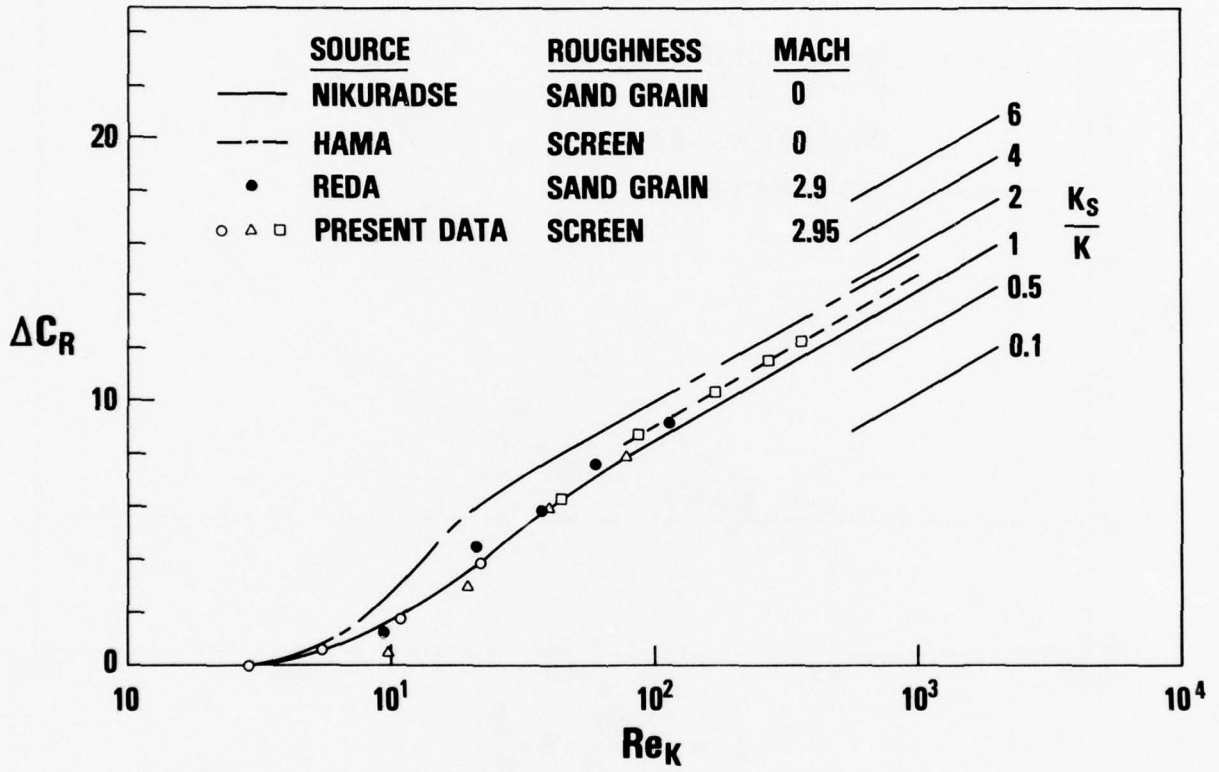

FIGURE 33 SHIFT IN THE LAW-OF-THE-WALL CONSTANT WITH ROUGHNESS

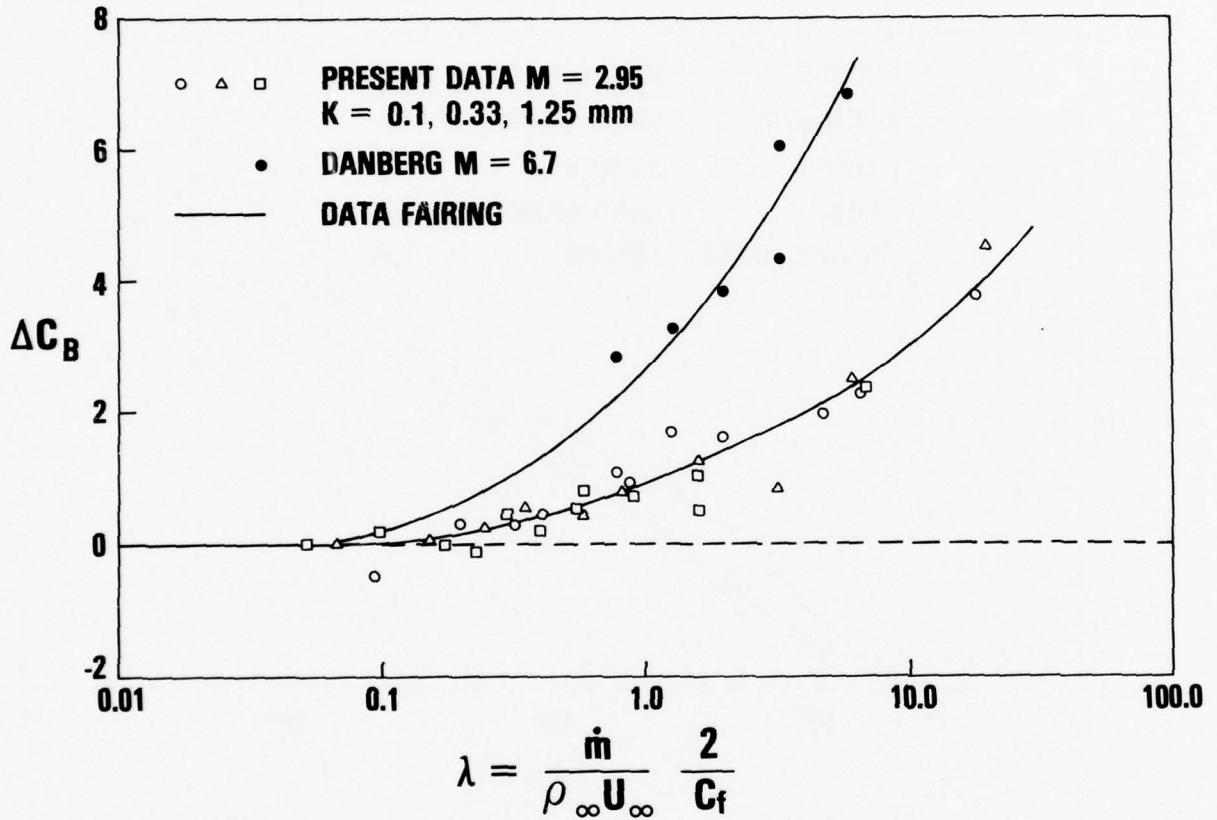

FIGURE 34 SHIFT IN THE LAW-OF-THE-WALL CONSTANT WITH BLOWING

Appendix A
DATA TABULATION

DISCUSSION OF TABULAR DATA

The data which are analyzed in the main section of the report are documented in the tables of this appendix. Axial Mach number distributions, boundary-layer profile surveys and skin-friction measurements are presented for the reader to conduct his own analysis.

Tables A-1 and A-2 present the general testing matrix in terms of test conditions and wind tunnel run numbers for the boundary-layer profile and skin-friction measurements, respectively. Four groupings of data are presented, each representing a different surface roughness condition. Within each of these groupings are the data for the four blowing conditions. Reynolds numbers are indicated in each case. Tables A-3 and A-4 present the detailed listings of these profile and skin-friction data according to run number.

NOZZLE FLOW

The nozzle contour was designed using a method-of-characteristics computer code with a boundary-layer displacement correction. The inviscid core flow was determined first and then the boundary-layer displacement was added to obtain the final contour.

The Mach number distribution along the test plate was prescribed by a cubic relation of the form:

$$M = 2.9 - 1.9 \left(1.0 + 0.65972 \frac{X}{X_T} \right) \left(1 - \frac{X}{X_T} \right)^2 \quad (\text{A-1})$$

where $X_T = 1.143$ - meters was the beginning of the nozzle test rhombus. For X greater than X_T , in the uniform flow section of the nozzle, the Mach number was specified to equal 2.9. A comparison of the prescribed and measured Mach number distributions is shown in Figure A-1. The region of investigation, i.e., the portion of the nozzle which houses the porous test samples, skin-friction balance, and survey probes, was within the uniform flow section of the nozzle. In this region the flow was found to be free of pressure gradients and flow disturbances as confirmed by axial Pitot pressure surveys. The test section Mach number reached values which were slightly different from the prescribed value for each of the different test conditions. This variation resulted from the effects of Reynolds number, roughness and blowing on the growth of the nozzle-wall boundary layers.

The wall temperature along the test plate was maintained at room temperature conditions. The wind tunnel supply temperature was then adjusted to provide a zero heat transfer to the test plate. Under these conditions, the test plate temperature remained constant, equal to the adiabatic-wall condition. In the throat region of the nozzle, where the Mach number is low and the adiabatic wall temperature higher, the test plate was heated in order that an adiabatic condition be maintained along the full length of development of the nozzle-wall boundary layer. Measured values of the boundary-layer enthalpy thickness (which are an indication of the energy removal via heat transfer to the wall) showed that near-adiabatic conditions were obtained in all cases.

DATA INTERPOLATION

Two data interpolations had to be performed in order to match skin-friction and boundary-layer profile data to (1) equivalent flow conditions and (2) a common X location. The first interpolation arises from the fact that profile surveys were obtained only at discrete Reynolds number conditions whereas the skin-friction results were obtained more or less continuously over the complete range of Reynolds numbers. The second interpolation is needed to match data to a common measuring location since the profile surveys were obtained at the 1.98-meter location and the skin friction values were measured over the drag element whose center was located at the 1.88-meter station.

In the first interpolation, values of the boundary-layer momentum thickness had to be evaluated for conditions which corresponded to the skin-friction measurements. From the momentum integral relationship for zero-pressure-gradient flow we have:

$$\frac{d\theta}{dX} = \frac{C_f}{2} + \frac{\dot{m}}{\rho_\infty U_\infty} \quad (\text{A-2})$$

with simplifications in integration we obtain:

$$\theta \approx \theta_I + \frac{C_f}{2} + \left(\frac{\dot{m}}{\rho_\infty U_\infty} \right) \Delta X \quad (\text{A-3})$$

where θ_I is the value of the momentum thickness at the beginning of the roughness and blowing, ΔX is the distance from the beginning of roughness and blowing to the measuring location, and C_f and \dot{m} are assumed constant over the ΔX distance. By applying this relationship to the cases with and without roughness and blowing, and computing the difference, one obtains:

$$\left(\theta - \theta_o \right) \approx \left(\frac{C_f - C_{fo}}{2} + \frac{\dot{m}}{\rho_\infty U_\infty} \right) \Delta X \quad (\text{A-4})$$

Figure A-2 shows a plot of this relationship which compares the measured value of the momentum thickness from the profile surveys with the corresponding skin-friction measurement and blowing rate. (θ_o and C_{fo} were determined from curve fits of the smooth-wall, non-blowing baseline data in terms of the local length Reynolds number.) With this relationship, values of the momentum thickness could be evaluated for the intermediate Reynolds number conditions which corresponded to the skin-friction measurements. For example, values of the momentum thickness at the 1.98 meter station were evaluated from the relationship:

$$\left(\theta - \theta_o \right) = 99.06 \left(\frac{C_f - C_{fo}}{2} + \frac{\dot{m}}{\rho_\infty U_\infty} \right) \quad (\text{A-5})$$

where

$$\log_{10} \theta_o = - 0.1876 \log_{10} R_e + 0.5224525 \quad (\text{A-6})$$

$$\begin{aligned} \log_{10} C_{fo} = & 0.0641184917 - 0.711147673 \log_{10} R_e \\ & + 0.041038624 (\log_{10} R_e)^2 \end{aligned} \quad (\text{A-7})$$

with θ in centimeters and R_e in units of 1/meter. A comparison of interpolated and measured values of momentum thickness are given in Figures A-3a to A-3d for data including the effects of roughness and blowing.

In the second interpolation the variation of θ with X was required. This was performed using the assumption of a linear growth in the boundary layer momentum thickness over the distance between profile and skin friction measuring stations. The values of θ at the 1.88 - meter station were computed from the value of θ at the 1.98-meter station by the relation:

$$\theta \Big|_{X = 1.88\text{m}} = 0.956 \theta_o \Big|_{X = 1.98\text{m}} + 0.895 (\theta - \theta_o) \Big|_{X = 1.98\text{m}} \quad (\text{A-8})$$

Where the constant 0.956 is related to the smooth-wall, non-blowing variation of θ with X and the constant 0.895 accounts for the growth of the boundary layer from the beginning of the roughness and blowing. Values of θ_o and θ are from equations A-6 and A-5, respectively. Values of momentum thickness which are presented in the skin-friction tabulation, Table A-4, were computed using equation A-8.

Values of the skin-friction coefficient which are presented in the boundary layer tabulations, Table A-3, are values which were interpolated from C_f vs. $R_{e\theta}$ tabulations. The data for the appropriate roughness and blowing condition was merely interpolated for the value of the momentum thickness Reynolds number which corresponded to the profile survey.

COMPUTER NOMENCLATURE

The nomenclature used in the computerized tabular output is defined as follows:

CF	= C_f	= skin friction coefficient
D	= ρ	= density
DE	= ρ_∞	= free-stream density
DEL	= δ	= boundary layer thickness
DSTR	= δ^*	= displacement thickness
M	= M	= local Mach number
MDOT	= \dot{m}	= mass transfer rate per unit area
ME	= M_∞	= free-stream Mach number
PO	= P_o	= tunnel supply pressure
PSW	= P_{sw}	= local wall static pressure
RE	= $\frac{\rho_\infty u_\infty}{\mu_\infty}$	= free-stream Reynolds number per meter
RETH	= $\frac{\rho_\infty u_\infty \theta}{\mu_\infty}$	= momentum thickness Reynolds number
T	= T	= static temperature
TAUW	= τ_w	= wall shear stress
TE	= T_∞	= free-stream static temperature
TW	= T_w	= wall temperature
TT	= T_t	= stagnation temperature
TTE	= T_{t_∞}	= free-stream stagnation temperature
TO	= T_o	= tunnel supply temperature
TH	= θ	= momentum thickness
THE	= θ_E	= energy thickness
THH	= θ_H	= enthalpy thickness
U	= u	= velocity
UE	= u_∞	= free-stream velocity
X	= x	= axial distance in flow direction measured from nozzle throat
Y	= y	= distance normal to flat plate surface

The units used in the computerized tabular output conform to the International Standard of Units (Ref. A-1) and are defined as:

CM	= centimeters
DEG.K	= degrees Kelvin
KG/M3	= kilograms per meter cubed
KG/M2 SEC	= kilograms per meter squared per second
M	= meters
M/S	= meters per second
N/M2	= newtons per meter squared

Two symbols are used in the profile data listing and are defined as:

*	= denotes the edge of the boundary-layer, δ , where $M/M_\infty \geq 0.995$
**	= denotes free-stream location, if different from "*" designation

Reference

A-1 Mechtly, E. A., "The International System of Units," NASA SP-7012

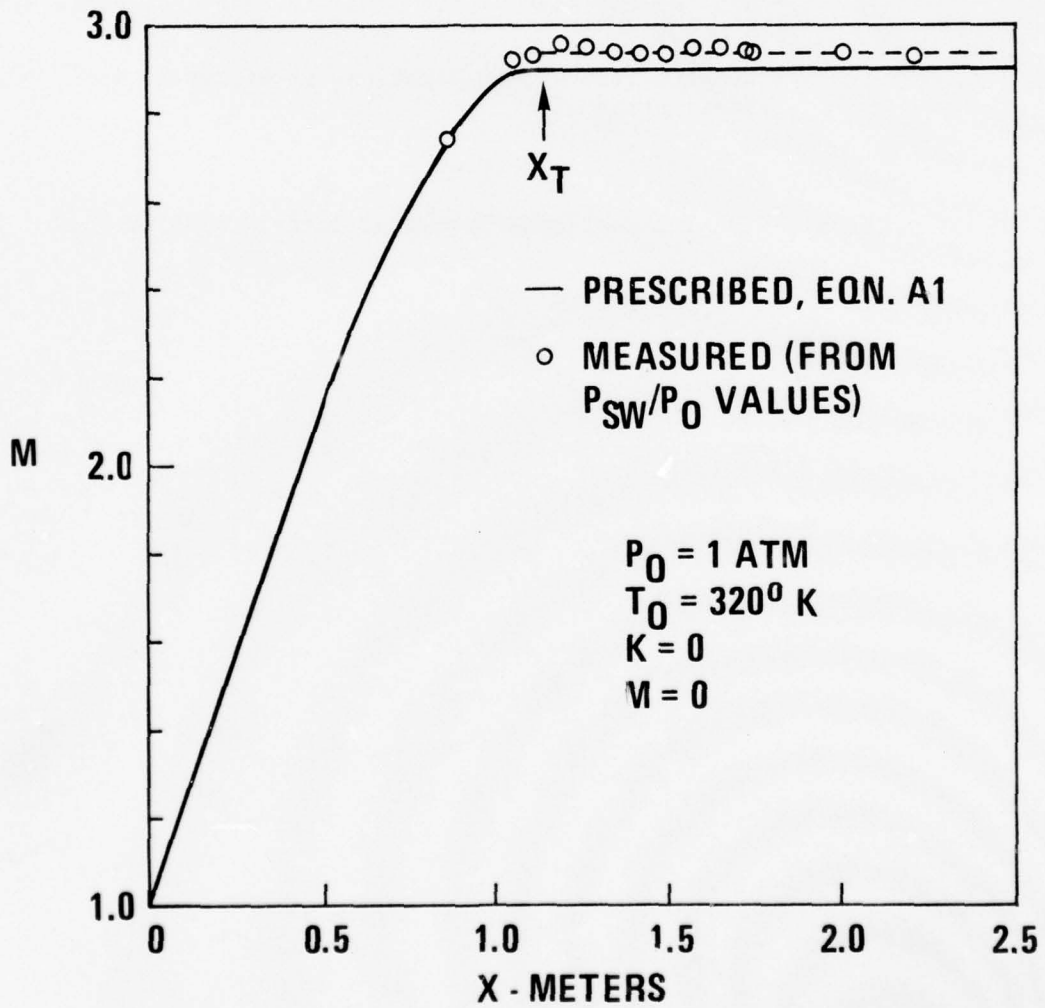
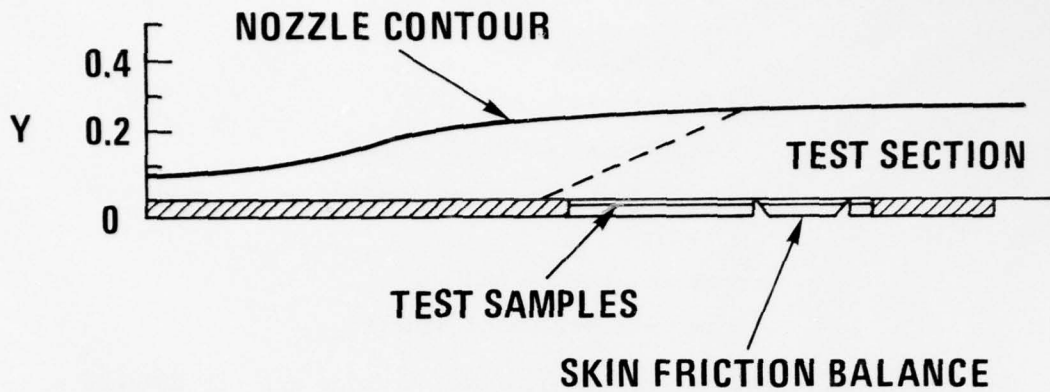

FIGURE A-1 NOZZLE MACH NUMBER DISTRIBUTION

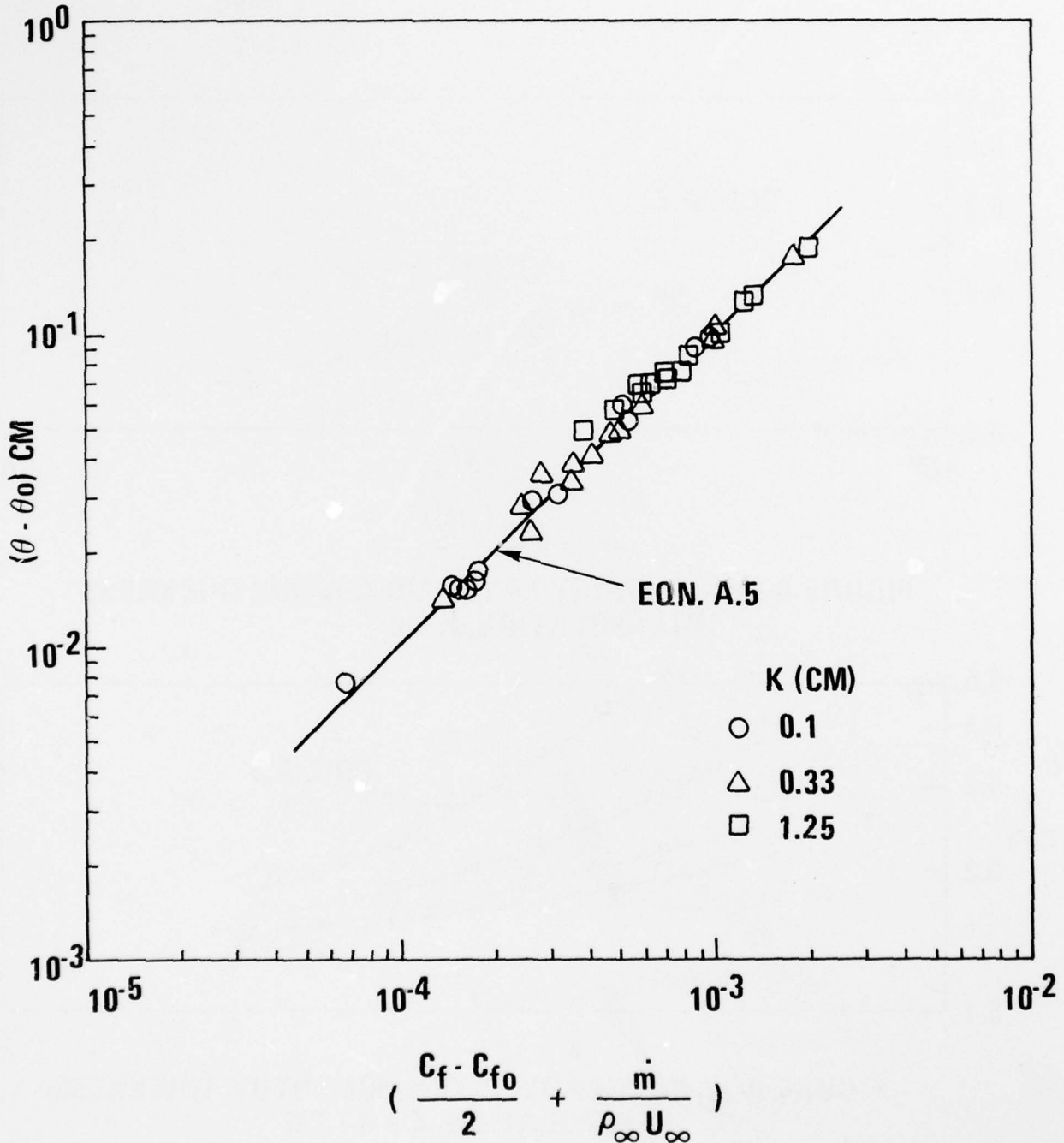

FIGURE A-2 BOUNDARY LAYER MOMENTUM THICKNESS INTERPOLATION RELATIONSHIP

\dot{m} (KG/M² SEC)

- 0.0
- △ 0.0146
- 0.0488
- ◇ 0.146

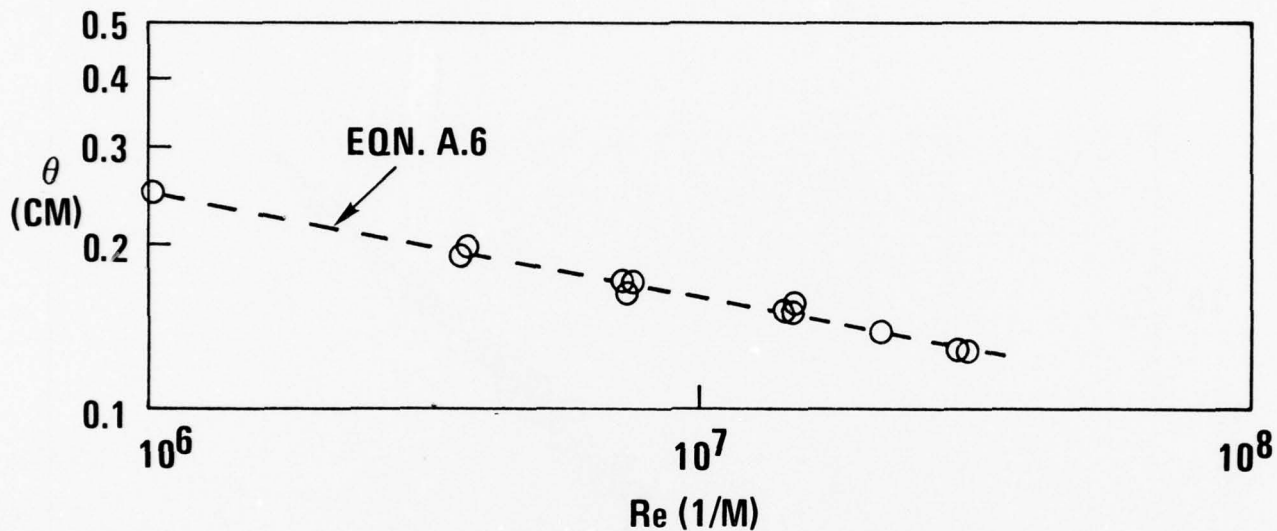

FIGURE A-3a BOUNDARY LAYER MOMENTUM THICKNESS INTERPOLATION, $K = 0$

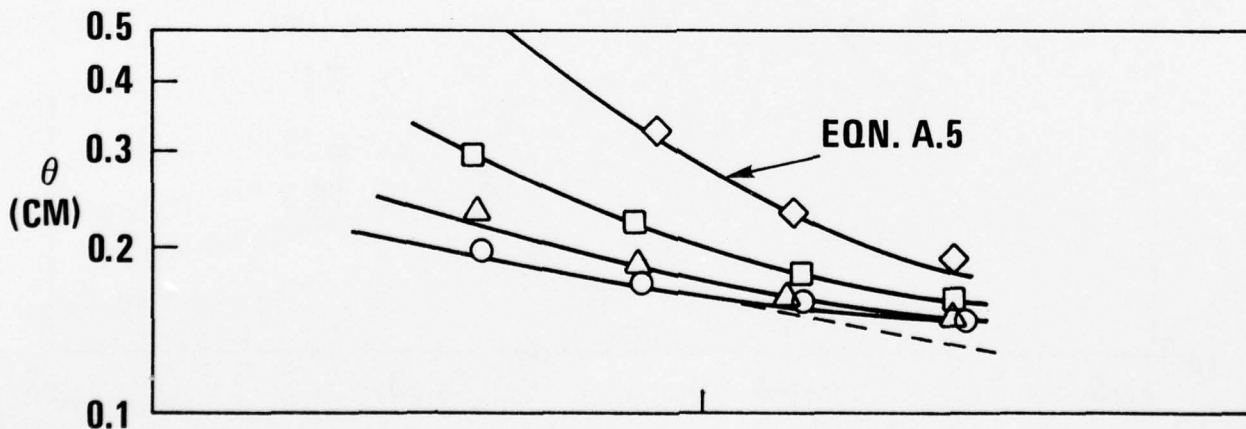

FIGURE A-3b BOUNDARY LAYER MOMENTUM THICKNESS INTERPOLATION, $K = 0.1$ CM

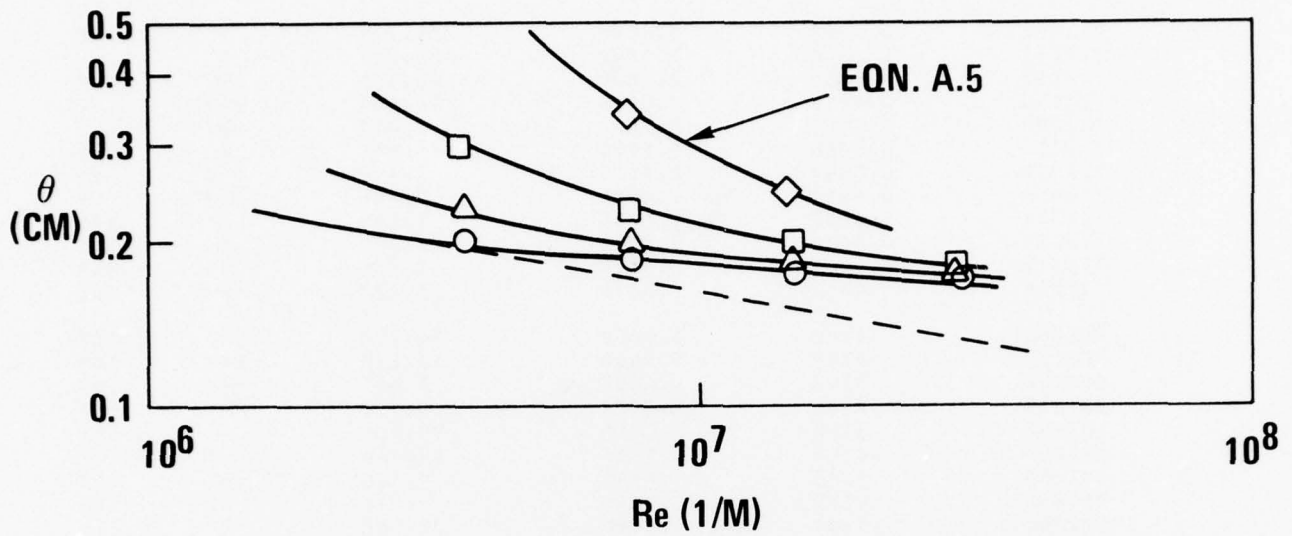

FIGURE A-3c BOUNDARY LAYER MOMENTUM THICKNESS INTERPOLATION, $K = 0.33$ CM

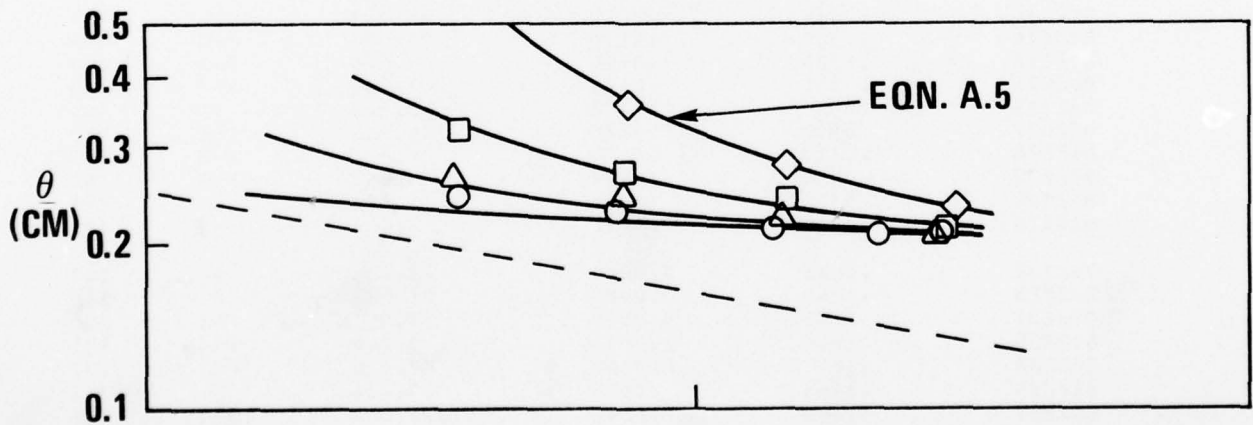

FIGURE A-3d BOUNDARY LAYER MOMENTUM THICKNESS INTERPOLATION, $K = 1.25$ CM

NSWC TR 79-153

TABLE A-1 BOUNDARY LAYER PROFILE TEST RUNS

RUN NUMBER	K (CM)	MDOT (KG/M2S)	RE*10-6 (1/M)	PRESSURE TEMPERATURE	PAGE
711282	0.0000	0.0000	30.774	P	88
712011	0.0000	0.0000	29.321	P	89
712012	0.0000	0.0000	21.402	P	90
712053	0.0000	0.0000	14.407	P-T	92
711283	0.0000	0.0000	14.857	P	93
712013	0.0000	0.0000	14.606	P	94
712051	0.0000	0.0000	7.498	P-T	96
712052	0.0000	0.0000	3.834	P-T	98
711281	0.0000	0.0000	7.289	P	100
712014	0.0000	0.0000	7.373	P	102
712015	0.0000	0.0000	3.736	P	104
712016	0.0000	0.0000	1.027	P	106
801261	.0102	0.0000	30.138	P	107
801251	.0102	0.0000	15.275	P-T	108
801252	.0102	0.0000	7.645	P-T	109
801253	.0102	0.0000	3.979	P-T	110
801262	.0102	.0146	29.054	P	111
801254	.0102	.0146	14.401	P-T	112
801255	.0102	.0146	7.729	P-T	113
801256	.0102	.0146	3.916	P-T	115
801263	.0102	.0488	28.908	P	116
801257	.0102	.0488	15.103	P-T	118
801258	.0102	.0488	7.584	P-T	119
801259	.0102	.0488	3.817	P-T	121
801264	.0102	.1465	28.811	P	123
801265	.0102	.1465	14.586	P	125
812510	.0102	.1465	8.282	P-T	127
802031	.0330	0.0000	29.987	P	129
802071	.0330	0.0000	14.710	P-T	130
802072	.0330	0.0000	7.636	P-T	131
802073	.0330	0.0000	3.755	P-T	132
802032	.0330	.0146	29.313	P	134
802074	.0330	.0146	14.934	P-T	136
802075	.0330	.0146	7.529	P-T	137
802076	.0330	.0146	3.831	P-T	138
802033	.0330	.0488	28.500	P	140
802077	.0330	.0488	14.835	P-T	142
802078	.0330	.0488	7.429	P-T	143
802079	.0330	.0488	3.697	P-T	144
802034	.0330	.1465	14.434	P	145
820710	.0330	.1465	7.490	P-T	146
802222	.1245	0.0000	28.433	P	147
802223	.1245	0.0000	21.584	P	148
802234	.1245	0.0000	13.951	P-T	150
802235	.1245	0.0000	7.249	P-T	151
802236	.1245	0.0000	3.710	P-T	153
802224	.1245	.0146	27.230	P	155
802237	.1245	.0146	14.518	P-T	156
802238	.1245	.0146	7.399	P-T	157
802239	.1245	.0146	3.659	P-T	158
802231	.1245	.0488	29.185	P	160
802241	.1245	.0488	14.690	P-T	162
802242	.1245	.0488	7.530	P-T	164
802243	.1245	.0488	3.758	P-T	166
802232	.1245	.1465	30.154	P	168
802233	.1245	.1465	14.669	P	170
802244	.1245	.1465	14.897	P-T	172
802245	.1245	.1465	7.549	P-T	174

P - PRESSURE SURVEY ONLY

P-T - BOTH PRESSURE AND TEMPERATURE SURVEYS

NSWC TR 79-153

TABLE A-2 SKIN FRICTION TEST RUNS

RUN NUMBER	K (CM)	MDOT (KG/M2S)	BALANCE RANGE (N/M2)	PAGE
711211	0.0000	0.0000	125.	176
711231	0.0000	0.0000	125.	176
711281	0.0000	0.0000	125.	176
711282	0.0000	0.0000	125.	176
712011	0.0000	0.0000	125.	177
801231	.0102	0.0000	125.	177
801241	.0102	0.0000	125.	179
801271	.0102	0.0000	25.	179
801242	.0102	.0146	125.	180
801272	.0102	.0146	25.	180
801243	.0102	.0488	125.	181
801273	.0102	.0488	25.	181
801244	.0102	.1465	125.	182
801274	.0102	.1465	25.	183
802021	.0330	0.0000	25.	184
802031	.0330	0.0000	250.	184
802071	.0330	0.0000	125.	185
802022	.0330	.0146	25	186
802032	.0330	.0146	250.	186
802074	.0330	.0146	125.	187
802023	.0330	.0488	25.	188
802033	.0330	.0488	250.	188
802077	.0330	.0488	125.	189
802024	.0330	.1465	25.	189
802034	.0330	.1465	250.	190
802078	.0330	.1465	125.	191
822221	.1245	0.0000	25.	192
822225	.1245	0.0000	250.	192
822229	.1245	0.0000	125.	193
822222	.1245	.0146	25.	195
822226	.1245	.0146	250.	195
822210	.1245	.0146	125.	196
822223	.1245	.0488	25.	196
822227	.1245	.0488	250.	197
822211	.1245	.0488	125.	198
822224	.1245	.1465	25.	200
822228	.1245	.1465	250.	200
822212	.1245	.1465	125.	201

NSWC TR 79-153

TABLE A-3 BOUNDARY LAYER PROFILE LISTING
RUN NO 711282

X = 1.981E+00 M	ME = 2.933E+00	DEL = 2.521E+00 CM
PO = 4.171E+05 N/M2	DE = 3.876E-01 KG/M3	DSTR = 6.305E-01 CM
TO = 3.098E+02 DEG.K	TE = 1.138E+02 DEG.K	TH = 1.289E-01 CM
PSW = 1.260E+04 N/M2	UE = 6.274E+02 M/S	THE = 2.358E-01 CM
TW = 2.974E+02 N/M2	RE = 3.077E+07 1/M	THH = 7.528E-03 CM
TAUW = 8.335E+01 N/M2	CF = 1.094E-03	RFTH = 1.007E+05
K = 0. CM	MDOT = 0. KG/M2*5	

N	Y (CM)	M	TT/TTE	D/DE	T/TE	U/UE
1	0.0000	0.0000	.9601	.3828	2.6124	0.0000
2	.0064	.7617	.9617	.4265	2.3445	.3976
3	.0165	.9160	.9648	.4448	2.2480	.4682
4	.0241	1.0366	.9684	.4611	2.1689	.5204
5	.0368	1.1962	.9700	.4873	2.0520	.5841
6	.0495	1.3050	.9724	.5067	1.9737	.6250
7	.0876	1.4805	.9778	.5407	1.8496	.6864
8	.1181	1.5584	.9796	.5574	1.7940	.7116
9	.1486	1.6039	.9807	.5676	1.7619	.7258
10	.1943	1.6679	.9816	.5827	1.7161	.7448
11	.2553	1.7292	.9830	.5974	1.6738	.7627
12	.3264	1.8003	.9841	.6156	1.6245	.7823
13	.4128	1.8648	.9856	.6323	1.5816	.7995
14	.4763	1.9141	.9879	.6446	1.5514	.8127
15	.5931	2.0054	.9906	.6694	1.4938	.8356
16	.6515	2.0821	.9916	.6920	1.4452	.8533
17	.8522	2.2329	.9936	.7387	1.3537	.8856
18	1.2611	2.4956	.9951	.8294	1.2057	.9342
19	1.4211	2.6035	.9976	.8678	1.1523	.9528
20	1.6294	2.7392	1.0012	.9179	1.0895	.9747
21	1.6904	2.7909	1.0015	.9387	1.0653	.9820
22	1.7056	2.7862	1.0008	.9374	1.0668	.9810
23	1.8301	2.8464	1.0005	.9626	1.0389	.9890
24	1.9723	2.8926	1.0000	.9826	1.0177	.9948
* 25	2.5210	2.9334	1.0000	1.0000	1.0000	1.0000

NSWC TR 79-153

TABLE A-3 BOUNDARY LAYER PROFILE LISTING
KUN NO 712011

X = 1.981E+00 M ME = 2.939E+00 DEL = 2.308E+00 CM
 PO = 4.122E+05 N/M2 DE = 3.731E-01 KG/M3 DSTP = 6.302E-01 CM
 TO = 3.185E+02 DEG.K TE = 1.168E+02 DEG.K TH = 1.299E-01 CM
 PSW = 1.240E+04 N/M2 UE = 6.366E+02 M/S THE = 2.375E-01 CM
 TW = 3.003E+02 N/M2 RE = 2.932E+07 1/M THH = 1.003E-02 CM
 TAUW = 8.303E+01 N/M2 CF = 1.099E-03 KETH = 9.667E+04
 K = 0. CM MDOT = 0. KG/M2*5

N	Y (CM)	M	TT/TTE	D/DE	T/TE	U/UE
1	0.0000	0.0000	.9430	.3888	2.5720	0.0000
2	.0064	.7734	.9551	.4298	2.3268	.4014
3	.0140	.8932	.9591	.4433	2.2560	.4565
4	.0191	.9614	.9612	.4519	2.2127	.4866
5	.0292	1.1052	.9645	.4730	2.1143	.5468
6	.0343	1.1816	.9676	.4847	2.0632	.5775
7	.0495	1.2958	.9707	.5046	1.9820	.6207
8	.0572	1.3345	.9689	.5137	1.9487	.6338
9	.0648	1.3905	.9714	.5234	1.9106	.6540
10	.0800	1.4578	.9766	.5350	1.8693	.6781
11	.0927	1.4979	.9779	.5431	1.8411	.6915
12	.1003	1.5196	.9768	.5487	1.8225	.6980
13	.1054	1.5337	.9772	.5517	1.8127	.7026
14	.1054	1.5337	.9766	.5520	1.8116	.7024
15	.1384	1.5919	.9779	.5649	1.7701	.7206
16	.1689	1.6350	.9799	.5742	1.7416	.7341
17	.1994	1.6719	.9804	.5830	1.7153	.7450
18	.2527	1.7360	.9806	.5992	1.6688	.7631
19	.2858	1.7624	.9833	.6045	1.6543	.7713
20	.2883	1.7660	.9822	.6061	1.6498	.7718
21	.3289	1.8016	.9833	.6149	1.6263	.7817
22	.3721	1.8418	.9839	.6254	1.5989	.7924
23	.4128	1.8745	.9842	.6343	1.5766	.8008
24	.4686	1.9206	.9850	.6468	1.5461	.8126
25	.5194	1.9599	.9874	.6566	1.5231	.8230
26	.5601	1.9902	.9883	.6649	1.5040	.8305
27	.6007	2.0248	.9880	.6753	1.4807	.8384
28	.6439	2.0541	.9852	.6861	1.4574	.8437
29	.6769	2.0794	.9883	.6918	1.4455	.8507
30	.7125	2.1056	.9903	.6985	1.4316	.8572
31	.7531	2.1358	.9899	.7083	1.4119	.8635
32	.8014	2.1681	.9901	.7184	1.3920	.8704
33	.8598	2.2123	.9901	.7327	1.3648	.8794
34	.9055	2.2428	.9903	.7426	1.3465	.8855
35	.9716	2.2915	.9916	.7580	1.3192	.8955
36	1.0122	2.3244	.9918	.7691	1.3003	.9018
37	1.0554	2.3493	.9919	.7776	1.2860	.9064
38	1.3373	2.5501	.9955	.8473	1.1802	.9426
39	1.5278	2.6769	.9965	.8952	1.1171	.9627
40	1.6828	2.7869	.9988	.9373	1.0669	.9795
41	1.8606	2.8761	1.0000	.9732	1.0276	.9920
42	2.0612	2.9227	1.0003	.9927	1.0074	.9981
* 43	2.3076	2.9390	1.0000	1.0000	1.0000	1.0000
44	2.5108	2.9337	.9975	1.0002	.9998	.9981
45	2.6810	2.9386	.9958	1.0040	.9960	.9978
46	2.9655	2.9364	.9964	1.0025	.9975	.9979
47	3.1737	2.9358	.9964	1.0023	.9977	.9978
48	3.4201	2.9370	.9952	1.0040	.9960	.9973
49	3.7808	2.9375	.9940	1.0054	.9947	.9968
50	4.0348	2.9386	.9928	1.0070	.9930	.9963

NSWC TR 79-153

TABLE A-3 BOUNDARY LAYER PROFILE LISTING
RUN NO 712012

X = 1.981E+00 M	ME = 2.914E+00	DEL = 2.097E+00 CM
PO = 3.092E+05 N/M2	DE = 2.767E-01 KG/M3	DSTR = 6.417E-01 CM
TO = 3.198E+02 DEG.K	TE = 1.185E+02 DEG.K	TH = 1.391E-01 CM
PSW = 9.401E+03 N/M2	UE = 6.359E+02 M/S	THE = 2.526E-01 CM
TW = 2.924E+02 N/M2	RE = 2.140E+07 1/M	THH = 1.963E-02 CM
TAUW = 6.335E+01 N/M2	CF = 1.133E-03	RETH = 7.555E+04
K = 0. CM	MDOT = 0. KG/M2*5	

N	Y (CM)	M	TT/TTE	D/DE	T/TE	U/UUE
1	0.0000	0.0000	.9144	.4053	2.4676	0.0000
2	.0064	.7437	.9271	.4440	2.2525	.3830
3	.0292	1.0787	.9390	.4865	2.0556	.5307
4	.0495	1.2641	.9429	.5186	1.9282	.6023
5	.0749	1.3953	.9473	.5435	1.8398	.6495
6	.0978	1.4669	.9525	.5565	1.7969	.6748
7	.1384	1.5559	.9520	.5777	1.7310	.7024
8	.1435	1.5644	.9529	.5793	1.7263	.7053
9	.1689	1.6042	.9542	.5883	1.6999	.7177
10	.2045	1.6442	.9549	.5979	1.6725	.7297
11	.2273	1.6704	.9546	.6048	1.6534	.7370
12	.2451	1.6911	.9559	.6094	1.6409	.7433
13	.2807	1.7260	.9581	.6172	1.6201	.7539
14	.3035	1.7475	.9588	.6226	1.6063	.7600
15	.3493	1.7875	.9589	.6334	1.5787	.7707
16	.3797	1.8110	.9602	.6391	1.5647	.7774
17	.4077	1.8337	.9615	.6446	1.5513	.7837
18	.4559	1.8711	.9632	.6541	1.5287	.7939
19	.4813	1.8954	.9634	.6611	1.5127	.7999
20	.5321	1.9320	.9627	.6723	1.4875	.8086
21	.5677	1.9661	.9660	.6802	1.4702	.8180
22	.6261	1.9965	.9692	.6872	1.4553	.8265
23	.6972	2.0520	.9725	.7020	1.4246	.8405
24	.7912	2.1270	.9753	.7238	1.3816	.8579
25	.8446	2.1632	.9769	.7344	1.3617	.8662
26	.8877	2.1886	.9781	.7418	1.3481	.8720
27	.9335	2.2169	.9818	.7484	1.3362	.8793
28	1.0147	2.2807	.9865	.7664	1.3047	.8940
29	1.1087	2.3447	.9900	.7859	1.2724	.9076
30	1.2154	2.4197	.9925	.8106	1.2337	.9222
31	1.2738	2.4598	.9923	.8254	1.2116	.9291
32	1.3424	2.5028	.9933	.8404	1.1899	.9368
33	1.4135	2.5502	.9938	.8579	1.1657	.9448
34	1.4694	2.5946	.9949	.8740	1.1442	.9524
35	1.4999	2.6149	.9960	.8809	1.1352	.9560
36	1.5354	2.6334	.9982	.8862	1.1285	.9600
37	1.5685	2.6590	1.0000	.8946	1.1178	.9647
38	1.6269	2.6987	.9991	.9112	1.0974	.9701
39	1.6726	2.7271	.9979	.9237	1.0826	.9737
40	1.7005	2.7513	.9984	.9331	1.0717	.9774
41	1.7513	2.7832	1.0009	.9438	1.0595	.9831
42	1.7844	2.8000	1.0012	.9505	1.0521	.9855
43	1.8225	2.8239	1.0012	.9605	1.0411	.9887
44	1.8707	2.8420	1.0045	.9648	1.0365	.9928
45	1.9266	2.8630	1.0062	.9721	1.0287	.9965
46	1.9749	2.8829	1.0042	.9825	1.0178	.9981
47	2.0079	2.8906	1.0019	.9880	1.0122	.9979
48	2.0511	2.8978	1.0009	.9921	1.0080	.9983
* 49	2.0968	2.9081	1.0005	.9969	1.0031	.9995
** 50	2.1247	2.9142	1.0000	1.0000	1.0000	1.0000

NSWC TR 79-153

TABLE A-3 BOUNDARY LAYER PROFILE LISTING
RUN NO 712012 CONT.

N	Y (CM)	M	TT/TTE	D/DE	T/TE	U/UE
51	2.1730	2.9199	.9995	1.0030	.9970	1.0005
52	2.2060	2.9230	.9989	1.0049	.9951	1.0006
53	2.2365	2.9266	.9979	1.0075	.9925	1.0005
54	2.2797	2.9297	.9961	1.0106	.9895	1.0000
55	2.3101	2.9308	.9956	1.0117	.9885	.9999
56	2.3432	2.9330	.9968	1.0114	.9887	1.0008
57	2.3762	2.9344	.9962	1.0126	.9876	1.0007
58	2.4041	2.9338	.9956	1.0129	.9873	1.0003
59	2.4321	2.9345	.9933	1.0156	.9846	.9992
60	2.4524	2.9339	.9944	1.0142	.9860	.9997
61	2.6124	2.9342	.9927	1.0161	.9842	.9988
62	2.7394	2.9302	.9908	1.0162	.9840	.9974
63	2.8435	2.9284	.9908	1.0155	.9847	.9972
64	2.9451	2.9259	.9919	1.0132	.9869	.9974
65	3.0671	2.9244	.9937	1.0108	.9893	.9981
66	3.1737	2.9251	.9943	1.0105	.9896	.9985
67	3.2779	2.9251	.9943	1.0105	.9896	.9985
68	3.3795	2.9249	.9937	1.0110	.9891	.9982
69	3.4811	2.9267	.9925	1.0130	.9872	.9978
70	3.5801	2.9248	.9901	1.0146	.9856	.9964
71	3.6005	2.9265	.9878	1.0177	.9826	.9955
72	3.7681	2.9275	.9844	1.0218	.9787	.9938
73	3.9180	2.9269	.9815	1.0245	.9761	.9923
74	4.0069	2.9253	.9797	1.0256	.9750	.9912
75	4.0526	2.9299	.9792	1.0282	.9726	.9915
76	4.0983	2.9258	.9803	1.0253	.9754	.9916
77	4.1593	2.9259	.9803	1.0253	.9753	.9916
78	4.2126	2.9263	.9786	1.0273	.9735	.9908
79	4.2761	2.9258	.9769	1.0289	.9719	.9898
80	4.3218	2.9254	.9774	1.0281	.9727	.9900
81	4.3777	2.9247	.9774	1.0278	.9730	.9900
82	4.4234	2.9246	.9774	1.0277	.9730	.9899
83	4.5530	2.9247	.9774	1.0278	.9730	.9900
84	4.6876	2.9230	.9785	1.0259	.9748	.9903
85	4.8603	2.9238	.9831	1.0214	.9790	.9927
86	5.1372	2.9221	.9825	1.0213	.9792	.9922
87	5.1499	2.9216	.9825	1.0211	.9793	.9921
88	5.4216	2.9230	.9842	1.0199	.9805	.9932
89	5.7010	2.9221	.9854	1.0183	.9820	.9937
90	5.9322	2.9201	.9871	1.0156	.9846	.9943
91	6.0846	2.9196	.9877	1.0148	.9854	.9945

NSWC TR 79-153

TABLE A-3 BOUNDARY LAYER PROFILE LISTING
RUN NO 712053

X = 1.981E+00 M ME = 2.922E+00 DEL = 2.412E+00 CM
 PU = 2.048E+05 N/M2 DE = 1.852E-01 KG/M3 DSTR = 7.577E-01 CM
 TO = 3.189E+02 DEG.K TE = 1.178E+02 DEG.K TH = 1.517E-01 CM
 PSW = 6.268E+03 N/M2 UE = 6.357E+02 M/S THE = 2.742E-01 CM
 TW = 2.988E+02 N/M2 RE = 1.441E+07 1/M THH = 6.551E-03 CM
 TAUW = 4.425E+01 N/M2 CF = 1.144E-03 RETH = 5.546E+04
 K = 0. CM MDOT = 0. KG/M2*S

N	Y (CM)	M	TT/TTE	D/DE	T/TE	U/UE
1	0.0000	0.0000	.9371	.3941	2.5374	0.0000
2	.0064	.5558	.9305	.4214	2.3729	.2930
3	.0114	.7524	.9370	.4388	2.2790	.3887
4	.0216	.9322	.9444	.4590	2.1785	.4709
5	.0267	1.0220	.9485	.4707	2.1246	.5098
6	.0343	1.1054	.9512	.4832	2.0697	.5442
7	.0419	1.1590	.9542	.4910	2.0365	.5660
8	.0495	1.2003	.9579	.4966	2.0135	.5829
9	.0673	1.2650	.9593	.5082	1.9677	.6073
10	.0724	1.2845	.9619	.5106	1.9584	.6152
11	.1283	1.4215	.9691	.5351	1.8688	.6650
12	.1537	1.4657	.9709	.5438	1.8389	.6802
13	.1892	1.5149	.9734	.5536	1.8064	.6968
14	.2172	1.5516	.9743	.5615	1.7808	.7086
15	.2553	1.5886	.9754	.5697	1.7552	.7203
16	.2883	1.6186	.9764	.5764	1.7349	.7296
17	.3315	1.6562	.9775	.5851	1.7091	.7410
18	.3620	1.6838	.9797	.5907	1.6928	.7497
19	.3950	1.7093	.9800	.5971	1.6749	.7570
20	.4331	1.7442	.9801	.6060	1.6501	.7667
21	.4737	1.7718	.9814	.6126	1.6325	.7747
22	.5118	1.8048	.9823	.6209	1.6105	.7838
23	.5601	1.8326	.9836	.6277	1.5932	.7916
24	.5931	1.8566	.9855	.6331	1.5796	.7985
25	.6464	1.9001	.9867	.6445	1.5515	.8100
26	.6871	1.9304	.9873	.6528	1.5318	.8176
27	.8319	2.0313	.9909	.6803	1.4700	.8428
28	.9182	2.0994	.9926	.7000	1.4285	.8587
29	1.0300	2.1742	.9978	.7201	1.3887	.8768
30	1.1417	2.2557	1.0004	.7448	1.3427	.8945
31	1.2383	2.3225	1.0024	.7659	1.3057	.9082
32	1.3475	2.4017	1.0035	.7926	1.2617	.9232
33	1.4948	2.5073	1.0048	.8297	1.2053	.9420
34	1.6421	2.6030	1.0022	.8678	1.1523	.9562
35	1.7437	2.6677	1.0004	.8946	1.1178	.9652
36	1.9444	2.7848	1.0016	.9407	1.0631	.9826
37	2.0968	2.8579	1.0020	.9706	1.0302	.9927
38	2.2390	2.8927	.9991	.9882	1.0119	.9958
* 39	2.4117	2.9126	.9985	.9973	1.0027	.9981
** 40	2.6099	2.9221	1.0000	1.0000	1.0000	1.0000
41	2.8029	2.9231	1.0000	1.0004	.9996	1.0001
42	2.9578	2.9233	.9997	1.0009	.9991	1.0000
43	3.1534	2.9254	1.0012	1.0003	.9997	1.0010
44	3.3414	2.9267	1.0004	1.0015	.9985	1.0008
45	3.7732	2.9237	1.0025	.9982	1.0018	1.0015
46	4.0018	2.9235	1.0042	.9964	1.0036	1.0023
47	4.3802	2.9183	1.0036	.9948	1.0053	1.0013
48	4.7892	2.9176	1.0053	.9928	1.0073	1.0021
49	5.0381	2.9179	1.0057	.9925	1.0075	1.0023
50	5.3150	2.9172	1.0055	.9924	1.0077	1.0021

NSWC TR 79-153

TABLE A-3 BOUNDARY LAYER PROFILE LISTING
RUN NO 711283

X = 1.981E+00 M ME = 2.921E+00 DEL = 2.363E+00 CM
 PU = 2.111E+05 N/M2 DE = 1.915E-01 KG/M3 DSTP = 7.004E-01 CM
 TO = 3.200E+02 DEG.K TE = 1.183E+02 DEG.K TH = 1.543E-01 CM
 PSW = 6.495E+03 N/M2 UE = 6.367E+02 M/S THF = 2.800E-01 CM
 TW = 2.909E+02 N/M2 RE = 1.486E+07 1/M THH = 2.739E-02 CM
 TAUW = 4.558E+01 N/M2 CF = 1.175E-03 RETH = 5.820E+04
 K = 0. CM MDOT = 0. KG/M2*S

N	Y (CM)	M	TT/TTE	D/DE	T/TE	U/UE
1	0.0000	0.0000	.9089	.4066	2.4594	0.0000
2	.0064	.6721	.9197	.4381	2.2825	.3477
3	.0038	.5841	.9191	.4295	2.3282	.3052
4	.0089	.7235	.9282	.4398	2.2736	.3735
5	.0140	.8521	.9369	.4517	2.2136	.4341
6	.0216	.9778	.9426	.4671	2.1411	.4899
7	.0267	1.0609	.9453	.4789	2.0879	.5249
8	.0343	1.1488	.9482	.4926	2.0301	.5604
9	.0394	1.1965	.9498	.5005	1.9980	.5791
10	.0470	1.2418	.9502	.5089	1.9651	.5960
11	.0521	1.2752	.9502	.5154	1.9402	.6082
12	.0826	1.3825	.9533	.5359	1.8662	.6467
13	.1003	1.4369	.9551	.5467	1.8292	.6654
14	.1029	1.4340	.9533	.5471	1.8279	.6638
15	.1334	1.4997	.9561	.5604	1.7845	.6859
16	.1638	1.5423	.9575	.5696	1.7557	.6997
17	.2070	1.5955	.9593	.5814	1.7201	.7165
18	.2375	1.6306	.9565	.5918	1.6896	.7257
19	.3543	1.7447	.9630	.6174	1.6198	.7603
20	.5296	1.8703	.9669	.6496	1.5395	.7946
21	.6744	1.9694	.9722	.6749	1.4816	.8208
22	.9131	2.1506	.9757	.7291	1.3716	.8624
23	1.1621	2.3238	.9810	.7835	1.2763	.8989
24	1.4948	2.5486	.9854	.8622	1.1598	.9398
25	1.7107	2.6871	.9921	.9104	1.0984	.9643
26	1.8504	2.7698	.9939	.9423	1.0612	.9770
27	1.9749	2.8290	.9946	.9663	1.0349	.9854
28	2.0739	2.8633	.9953	.9801	1.0203	.9903
* 29	2.3635	2.9167	.9999	.9984	1.0016	.9995
** 30	2.4575	2.9206	1.0000	1.0000	1.0000	1.0000
31	2.6988	2.9233	.9977	1.0035	.9965	.9992
32	2.8588	2.9215	.9965	1.0039	.9961	.9983
33	3.4862	2.9126	.9945	1.0021	.9979	.9962
34	3.7859	2.9138	.9945	1.0026	.9974	.9964
35	4.1720	2.9110	.9939	1.0020	.9980	.9957
36	4.5149	2.9098	.9921	1.0032	.9968	.9947
37	4.8501	2.9105	.9904	1.0053	.9947	.9939
38	5.1930	2.9125	.9928	1.0038	.9962	.9953

NSWC IR 79-153

TABLE A-3 BOUNDARY LAYER PROFILE LISTING
RUN NO 712013

X = 1.981E+00 M ME = 2.925E+00 DFL = 2.292E+00 CM
 PO = 2.073E+05 N/M2 DE = 1.875E-01 KG/M3 DSTR = 6.967E-01 CM
 TO = 3.192E+02 DEG.K TE = 1.177E+02 DEG.K TH = 1.546E-01 CM
 PSW = 6.352E+03 N/M2 UE = 6.363E+02 M/S THE = 2.802E-01 CM
 TW = 2.926E+02 N/M2 RE = 1.461E+07 1/M THH = 2.970E-02 CM
 TAUW = 4.468E+01 N/M2 CF = 1.178E-03 RETH = 5.729E+04
 K = 0. CM MDOT = 0. KG/M2*S

N	Y (CM)	M	TT/TTE	D/DE	T/TE	U/UE
1	0.0000	0.0000	.9166	.4024	2.4851	0.0000
2	.0064	.6627	.9264	.4331	2.3090	.3443
3	.0114	.7520	.9315	.4407	2.2690	.3873
4	.0140	.8244	.9330	.4491	2.2268	.4206
5	.0191	.9158	.9368	.4598	2.1751	.4618
6	.0216	.9753	.9386	.4677	2.1381	.4875
7	.0292	1.0844	.9421	.4836	2.0680	.5331
8	.0318	1.1245	.9434	.4898	2.0415	.5493
9	.0343	1.1720	.9455	.4972	2.0111	.5682
10	.0546	1.2861	.9503	.5165	1.9361	.6118
11	.0800	1.3754	.9538	.5330	1.8763	.6440
12	.1054	1.4382	.9553	.5458	1.8322	.6655
13	.1308	1.4828	.9557	.5556	1.7997	.6800
14	.1588	1.5296	.9561	.5663	1.7659	.6949
15	.1842	1.5659	.9578	.5739	1.7424	.7066
16	.2146	1.6015	.9578	.5826	1.7165	.7173
17	.2451	1.6386	.9568	.5925	1.6878	.7277
18	.2705	1.6618	.9558	.5990	1.6695	.7340
19	.2934	1.6891	.9572	.6052	1.6524	.7423
20	.3264	1.7178	.9587	.6118	1.6346	.7508
21	.3594	1.7418	.9595	.6177	1.6190	.7577
22	.3823	1.7653	.9607	.6232	1.6047	.7645
23	.4077	1.7799	.9629	.6257	1.5981	.7692
24	.4331	1.7983	.9646	.6297	1.5881	.7747
25	.5017	1.8538	.9674	.6433	1.5545	.7902
26	.6134	1.9342	.9710	.6640	1.5059	.8114
27	.9893	2.2059	.9723	.7485	1.3361	.8717
28	1.0630	2.2589	.9732	.7658	1.3059	.8825
29	1.1392	2.3050	.9744	.7807	1.2808	.8918
30	1.2154	2.3643	.9753	.8010	1.2485	.9031
31	1.2941	2.4179	.9766	.8192	1.2206	.9133
32	1.3856	2.4733	.9785	.8381	1.1932	.9236
33	1.4618	2.5299	.9816	.8567	1.1672	.9344
34	1.5380	2.5810	.9833	.8748	1.1431	.9434
35	1.6218	2.6354	.9857	.8939	1.1187	.9529
36	1.6777	2.6848	.9886	.9110	1.0977	.9616
37	1.7640	2.7328	.9919	.9272	1.0785	.9702
38	1.8555	2.7814	.9941	.9451	1.0581	.9781
39	1.9342	2.8243	.9956	.9615	1.0401	.9847
40	2.0257	2.8599	.9987	.9734	1.0273	.9909
41	2.1120	2.8860	1.0004	.9828	1.0175	.9952
42	2.2035	2.9054	1.0002	.9913	1.0088	.9976
* 43	2.2924	2.9184	1.0005	.9966	1.0034	.9994
** 44	2.3787	2.9252	1.0000	1.0000	1.0000	1.0000
45	2.5133	2.9305	.9989	1.0034	.9966	1.0001
46	2.6073	2.9312	.9977	1.0049	.9951	.9996
47	2.7115	2.9304	.9971	1.0052	.9949	.9992
48	2.8156	2.9290	.9965	1.0052	.9948	.9987
49	2.9248	2.9266	.9959	1.0048	.9952	.9981
50	3.0137	2.9260	.9953	1.0051	.9949	.9978

NSWC TR 79-153

TABLE A-3 BOUNDARY LAYER PROFILE LISTING
RUN NO 712013 CONT.

N	Y (CM)	M	TT/TTE	D/DE	T/TE	U/UE
51	3.1179	2.9235	.9935	1.0058	.9942	.9965
52	3.2118	2.9232	.9935	1.0057	.9943	.9965
53	3.2118	2.9235	.9941	1.0052	.9948	.9968
54	3.4836	2.9206	.9946	1.0035	.9965	.9967
55	3.7198	2.9219	.9958	1.0028	.9972	.9975
56	3.9510	2.9218	.9970	1.0016	.9985	.9981
57	4.2126	2.9200	.9975	1.0003	.9997	.9981
58	4.4818	2.9180	.9993	.9977	1.0023	.9987
59	4.7485	2.9184	1.0010	.9960	1.0040	.9997
60	5.0940	2.9202	1.0011	.9968	1.0032	.9999
61	5.4318	2.9180	1.0004	.9965	1.0035	.9993
62	5.7290	2.9151	1.0004	.9953	1.0048	.9989
63	6.0185	2.9141	.9992	.9961	1.0040	.9982
64	6.3259	2.9209	.9981	1.0000	1.0000	.9985
65	6.6358	2.9223	.9970	1.0018	.9982	.9981
66	6.9202	2.9237	.9970	1.0024	.9977	.9983
67	7.2352	2.9259	.9959	1.0045	.9955	.9980

NSWC TR 79-153

TABLE A-3 BOUNDARY LAYER PROFILE LISTING
RUN NO 712051

X = 1.981E+00 M	ME = 2.935E+00	DEL = 2.496E+00 CM
PO = 1.037E+05 N/M2	DE = 9.528E-02 KG/M3	DSTR = 8.587E-01 CM
TU = 3.159E+02 DEG.K	TE = 1.161E+02 DEG.K	TH = 1.723E-01 CM
PSW = 3.156E+03 N/M2	UE = 6.337E+02 M/S	THE = 3.084E-01 CM
TW = 2.938E+02 N/M2	RE = 7.498E+06 1/M	THH = 1.418E-02 CM
TAUW = 2.466E+01 N/M2	CF = 1.290E-03	RFTH = 3.279E+04
K = 0. CM	MDOT = 0. KG/M2*5	

N	Y (CM)	M	TT/TTE	D/DE	T/TTE	U/UE
1	0.0000	0.0000	.9298	.3951	2.5311	0.0000
2	.0064	.4101	.9231	.4113	2.4313	.2179
3	.0089	.4883	.9242	.4164	2.4014	.2578
4	.0165	.6573	.9255	.4312	2.3192	.3411
5	.0241	.8042	.9299	.4461	2.2416	.4103
6	.0292	.9116	.9332	.4590	2.1785	.4585
7	.0368	.9929	.9352	.4702	2.1267	.4934
8	.0419	1.0508	.9383	.4780	2.0921	.5180
9	.0622	1.1497	.9419	.4931	2.0281	.5579
10	.0749	1.2025	.9436	.5019	1.9926	.5785
11	.0851	1.2278	.9450	.5059	1.9766	.5882
12	.0978	1.2611	.9476	.5109	1.9571	.6012
13	.1156	1.2978	.9483	.5178	1.9311	.6146
14	.1308	1.3299	.9505	.5232	1.9113	.6266
15	.1461	1.3539	.9516	.5276	1.8955	.6352
16	.1791	1.4037	.9542	.5367	1.8633	.6529
17	.1969	1.4275	.9558	.5410	1.8486	.6614
18	.2121	1.4438	.9581	.5433	1.8407	.6675
19	.2146	1.4540	.9573	.5460	1.8316	.6705
20	.2223	1.4579	.9581	.5464	1.8302	.6721
21	.2578	1.4941	.9607	.5531	1.8081	.6846
22	.3010	1.5377	.9613	.5629	1.7767	.6985
23	.3493	1.5779	.9628	.5715	1.7498	.7113
24	.3899	1.6118	.9649	.5785	1.7286	.7221
25	.4636	1.6678	.9683	.5904	1.6938	.7397
26	.5118	1.7047	.9722	.5975	1.6737	.7515
27	.5702	1.7434	.9728	.6071	1.6471	.7624
28	.6007	1.7683	.9742	.6129	1.6316	.7697
29	.6591	1.8081	.9761	.6224	1.6068	.7810
30	.7125	1.8483	.9776	.6325	1.5811	.7920
31	.8014	1.9137	.9809	.6488	1.5414	.8096
32	.8852	1.9677	.9821	.6637	1.5068	.8231
33	1.0046	2.0556	.9873	.6865	1.4564	.8455
34	1.0833	2.1067	.9882	.7017	1.4251	.8570
35	1.1748	2.1782	.9904	.7228	1.3835	.8730
36	1.2408	2.2191	.9930	.7342	1.3619	.8825
37	1.3322	2.2849	.9947	.7549	1.3247	.8962
38	1.4186	2.3446	.9956	.7746	1.2909	.9078
39	1.4821	2.3878	.9968	.7887	1.2679	.9162
40	1.5837	2.4589	.9985	.8127	1.2304	.9295
41	1.6472	2.5021	.9996	.8276	1.2083	.9372
42	1.7031	2.5400	.9993	.8419	1.1878	.9433
43	1.7818	2.5907	1.0017	.8589	1.1642	.9526
44	1.8555	2.6379	1.0017	.8770	1.1402	.9599
45	1.9317	2.6899	1.0031	.8961	1.1159	.9683
46	1.9926	2.7289	1.0031	.9116	1.0970	.9740
47	2.0714	2.7783	1.0020	.9325	1.0723	.9804
48	2.1298	2.8112	1.0020	.9460	1.0571	.9849
49	2.1958	2.8414	1.0019	.9587	1.0431	.9889
50	2.2771	2.8725	1.0011	.9725	1.0283	.9926

NSWC TR 79-153

TABLE A-3 BOUNDARY LAYER PROFILE LISTING
RUN NO 712051 CONT.

N	Y (CM)	M	TT/TTF	D/DE	T/TE	U/UE
51	2.4016	2.9077	1.0012	.9873	1.0129	.9972
* 52	2.4956	2.9244	1.0003	.9954	1.0047	.9989
** 53	2.5794	2.9345	1.0000	1.0000	1.0000	1.0000
54	2.6556	2.9391	.9985	1.0035	.9965	.9998
55	2.7318	2.9423	.9990	1.0044	.9957	1.0005
56	2.8715	2.9448	.9984	1.0060	.9940	1.0005
57	2.9832	2.9451	.9987	1.0058	.9942	1.0007
58	3.0645	2.9448	.9992	1.0052	.9948	1.0009
59	3.1661	2.9436	.9978	1.0061	.9940	1.0000
60	3.2601	2.9424	.9986	1.0048	.9952	1.0003
61	3.3642	2.9417	.9997	1.0034	.9966	1.0007
62	3.4379	2.9410	.9994	1.0034	.9966	1.0005
63	3.5319	2.9417	1.0001	1.0030	.9971	1.0009
64	3.6563	2.9406	1.0003	1.0023	.9977	1.0009
65	3.7300	2.9421	1.0002	1.0030	.9970	1.0011
66	3.8265	2.9426	1.0012	1.0023	.9977	1.0016
67	3.8926	2.9426	.9999	1.0036	.9964	1.0010
68	3.9916	2.9426	1.0013	1.0022	.9978	1.0017
69	4.1085	2.9423	1.0016	1.0018	.9982	1.0018
70	4.2126	2.9415	1.0023	1.0007	.9993	1.0020
71	4.3193	2.9410	1.0024	1.0004	.9996	1.0020
72	4.4437	2.9396	1.0017	1.0005	.9995	1.0015
73	4.5504	2.9373	1.0023	.9989	1.0011	1.0015
74	4.6876	2.9350	1.0031	.9971	1.0029	1.0016
75	4.8679	2.9330	1.0037	.9956	1.0044	1.0017
76	5.0203	2.9308	1.0033	.9951	1.0049	1.0012
77	5.1905	2.9281	1.0039	.9933	1.0067	1.0012
78	5.5740	2.9269	1.0040	.9928	1.0073	1.0010
79	5.8458	2.9295	1.0050	.9929	1.0072	1.0018
80	6.0084	2.9313	1.0034	.9952	1.0048	1.0013
81	6.2065	2.9313	1.0047	.9940	1.0061	1.0019
82	6.3767	2.9303	1.0051	.9931	1.0069	1.0020
83	6.5265	2.9322	1.0044	.9946	1.0055	1.0019
84	6.7196	2.9328	1.0058	.9935	1.0066	1.0027
85	6.8263	2.9325	1.0051	.9941	1.0060	1.0023
86	6.9431	2.9332	1.0058	.9936	1.0064	1.0027
87	7.0599	2.9330	1.0060	.9934	1.0067	1.0028
88	7.1717	2.9342	1.0053	.9945	1.0055	1.0026
89	7.2987	2.9325	1.0055	.9937	1.0064	1.0025
90	7.4511	2.9315	1.0060	.9927	1.0073	1.0026
91	7.5298	2.9307	1.0059	.9924	1.0076	1.0025
92	7.5857	2.9303	1.0063	.9920	1.0081	1.0026
93	7.6365	2.9308	1.0066	.9919	1.0082	1.0028

NSWC TR 79-153

TABLE A-3 BOUNDARY LAYER PROFILE LISTING
RUN NO 712052

X = 1.981E+00 M ME = 2.913E+00 DEL = 2.699E+00 CM
 PO = 5.199E+04 N/M2 DE = 4.923E-02 KG/M3 DSTR = 9.675E-01 CM
 TO = 3.151E+02 DEG.K TE = 1.168E+02 DEG.K TH = 1.981E-01 CM
 PSW = 1.599E+03 N/M2 UE = 6.312E+02 M/S THE = 3.517E-01 CM
 TW = 2.922E+02 N/M2 RE = 3.834E+06 1/M THH = 2.282E-02 CM
 TAUW = 1.400E+01 N/M2 CF = 1.429E-03 KETH = 1.928E+04
 K = 0. CM MDOT = 0. KG/M2*S

N	Y (CM)	M	TT/TTE	D/DE	T/TE	U/UE
1	0.0000	0.0000	.9273	.3998	2.5012	0.0000
2	.0064	.3324	.9269	.4088	2.4461	.1785
3	.0064	.3392	.9242	.4104	2.4366	.1817
4	.0140	.4483	.9203	.4191	2.3862	.2377
5	.0191	.5240	.9181	.4260	2.3475	.2756
6	.0241	.5923	.9155	.4334	2.3074	.3089
7	.0292	.6844	.9146	.4433	2.2557	.3529
8	.0343	.7625	.9148	.4524	2.2105	.3891
9	.0394	.8364	.9153	.4618	2.1657	.4225
10	.0445	.9017	.9159	.4706	2.1247	.4512
11	.0521	.9671	.9168	.4800	2.0832	.4792
12	.0572	1.0099	.9190	.4857	2.0589	.4974
13	.0673	1.0683	.9206	.4946	2.0217	.5214
14	.0775	1.1113	.9230	.5009	1.9964	.5390
15	.0876	1.1547	.9247	.5079	1.9690	.5562
16	.0953	1.1797	.9259	.5119	1.9537	.5660
17	.1080	1.2066	.9275	.5161	1.9375	.5765
18	.1181	1.2302	.9293	.5197	1.9241	.5858
19	.1283	1.2551	.9299	.5243	1.9071	.5950
20	.1435	1.2810	.9308	.5290	1.8902	.6046
21	.1537	1.2987	.9322	.5319	1.8802	.6113
22	.1638	1.3141	.9340	.5341	1.8724	.6173
23	.1765	1.3293	.9350	.5367	1.8633	.6229
24	.1969	1.3545	.9366	.5411	1.8481	.6321
25	.2908	1.4499	.9426	.5587	1.7899	.6659
26	.3340	1.4909	.9440	.5673	1.7627	.6795
27	.4128	1.5507	.9479	.5792	1.7264	.6994
28	.5372	1.6348	.9537	.5966	1.6762	.7266
29	.6134	1.6848	.9572	.6072	1.6468	.7422
30	.6896	1.7406	.9608	.6197	1.6136	.7590
31	.7734	1.7912	.9626	.6323	1.5814	.7733
32	.8801	1.8576	.9661	.6486	1.5418	.7918
33	.9462	1.9048	.9698	.6597	1.5158	.8050
34	1.0655	1.9807	.9746	.6789	1.4729	.8252
35	1.1976	2.0644	.9782	.7021	1.4244	.8458
36	1.3627	2.1718	.9847	.7317	1.3667	.8716
37	1.4415	2.2231	.9851	.7484	1.3362	.8821
38	1.5431	2.2866	.9898	.7663	1.3049	.8967
39	1.6345	2.3471	.9932	.7846	1.2746	.9096
40	1.6345	2.3509	.9950	.7845	1.2748	.9112
41	1.7056	2.3904	.9958	.7978	1.2534	.9187
42	1.7666	2.4293	.9983	.8097	1.2350	.9267
43	1.8225	2.4618	1.0004	.8198	1.2199	.9334
44	1.9063	2.5201	1.0019	.8400	1.1904	.9439
45	1.9749	2.5621	1.0039	.8541	1.1708	.9517
46	2.0231	2.5938	1.0047	.8655	1.1553	.9570
47	2.0714	2.6297	1.0049	.8792	1.1374	.9627
48	2.1196	2.6635	1.0056	.8918	1.1213	.9682
49	2.1679	2.6925	1.0075	.9016	1.1092	.9734
50	2.2289	2.7241	1.0067	.9149	1.0930	.9777

NSWC TR 79-153

TABLE A-3 BOUNDARY LAYER PROFILE LISTING
 RUN NO 712052 CONT.

N	Y (CM)	M	TT/TTE	D/DE	T/TE	U/UE
51	2.2797	2.7547	1.0072	.9268	1.0790	.9823
52	2.3355	2.7805	1.0065	.9379	1.0662	.9856
53	2.4041	2.8119	1.0065	.9509	1.0516	.9899
54	2.4676	2.8356	1.0041	.9630	1.0384	.9919
55	2.5235	2.8578	1.0046	.9718	1.0290	.9951
56	2.5591	2.8652	1.0028	.9767	1.0238	.9952
57	2.6022	2.8754	1.0023	.9815	1.0188	.9963
58	2.6454	2.8882	1.0030	.9864	1.0138	.9983
* 59	2.6988	2.8987	1.0024	.9915	1.0086	.9993
60	2.7699	2.9098	1.0011	.9975	1.0026	1.0002
** 61	2.8105	2.9131	1.0000	1.0000	1.0000	1.0000
62	2.8791	2.9193	1.0001	1.0026	.9974	1.0008
63	2.9324	2.9222	.9986	1.0054	.9946	1.0004
64	2.9782	2.9255	.9973	1.0081	.9919	1.0002
65	3.0417	2.9288	.9973	1.0096	.9905	1.0006
66	3.1204	2.9308	.9966	1.0111	.9890	1.0005
67	3.1991	2.9308	.9966	1.0111	.9890	1.0005
68	3.2601	2.9324	.9963	1.0121	.9881	1.0006
69	3.3058	2.9334	.9964	1.0125	.9877	1.0008
70	3.3490	2.9348	.9949	1.0146	.9856	1.0002
71	3.6030	2.9348	.9949	1.0146	.9856	1.0002
72	3.8799	2.9336	.9956	1.0133	.9869	1.0004
73	4.1720	2.9317	.9961	1.0120	.9881	1.0004
74	4.5098	2.9248	.9968	1.0083	.9918	.9999
75	4.8654	2.9212	.9963	1.0072	.9928	.9992
76	5.2261	2.9176	.9980	1.0040	.9960	.9996
77	5.6045	2.9156	.9975	1.0036	.9964	.9991
78	6.0008	2.9153	.9975	1.0034	.9966	.9990
79	6.4783	2.9180	.9986	1.0035	.9965	.9999
80	6.8390	2.9180	.9983	1.0038	.9962	.9998
81	7.2098	2.9167	.9990	1.0026	.9974	1.0000

NSWC TR 79-153

TABLE A-3 BOUNDARY LAYER PROFILE LISTING
RUN NO 711281

X = 1.981E+00 M	ME = 2.905E+00	DEL = 2.485E+00 CM
PO = 1.056E+05 N/M2	DE = 9.546E-02 KG/M3	DSTR = 7.984E-01 CM
TO = 3.253E+02 DEG.K	TE = 1.210E+02 DEG.K	TH = 1.719E-01 CM
PSW = 3.288E+03 N/M2	UE = 6.407E+02 M/S	TPE = 3.094E-01 CM
TW = 2.975E+02 N/M2	RE = 7.289E+06 1/M	TTH = 2.633E-02 CM
TAUW = 2.539E+01 N/M2	CF = 1.297E-03	KETH = 3.180E+04
K = 0. CM	MDOT = 0. KG/M2*s	

N	Y (CM)	M	TT/TTE	D/DE	T/TTE	U/UE
1	0.0000	0.0000	.9145	.4068	2.4582	0.0000
2	.0064	.4980	.9252	.4220	2.3695	.2639
3	.0140	.6766	.9293	.4370	2.2885	.3523
4	.0140	.6787	.9299	.4369	2.2889	.3534
5	.0216	.8503	.9361	.4549	2.1985	.4340
6	.0318	1.0173	.9420	.4766	2.0981	.5072
7	.0394	1.0835	.9452	.4860	2.0577	.5350
8	.0445	1.1274	.9469	.4927	2.0296	.5528
9	.0521	1.1692	.9469	.5003	1.9990	.5690
10	.0724	1.2458	.9505	.5129	1.9498	.5988
11	.0902	1.3000	.9521	.5228	1.9128	.6189
12	.1156	1.3560	.9526	.5341	1.8723	.6386
13	.1765	1.4439	.9567	.5510	1.8149	.6695
14	.2629	1.5429	.9605	.5717	1.7492	.7024
15	.3772	1.6375	.9635	.5931	1.6860	.7318
16	.4407	1.6908	.9644	.6063	1.6494	.7474
17	.5042	1.7352	.9655	.6173	1.6199	.7602
18	.6185	1.8249	.9670	.6409	1.5603	.7846
19	.7099	1.8905	.9688	.6585	1.5187	.8019
20	.8090	1.9619	.9707	.6782	1.4744	.8199
21	.8649	1.9987	.9719	.6885	1.4523	.8291
22	.9563	2.0617	.9740	.7067	1.4151	.8442
23	1.0173	2.1069	.9755	.7199	1.3890	.8547
24	1.1011	2.1639	.9773	.7371	1.3566	.8675
25	1.2433	2.2874	.9805	.7764	1.2880	.8935
26	1.3373	2.3288	.9829	.7890	1.2674	.9024
27	1.3475	2.3441	.9850	.7927	1.2615	.9062
28	1.4008	2.3987	.9855	.8119	1.2317	.9163
29	1.5126	2.4357	.9871	.8240	1.2135	.9235
30	1.5888	2.4903	.9897	.8421	1.1876	.9341
31	1.6701	2.5491	.9913	.8630	1.1588	.9445
32	1.7564	2.5975	.9920	.8811	1.1350	.9525
33	1.9342	2.7018	.9946	.9200	1.0869	.9695
34	1.9901	2.7323	.9948	.9323	1.0726	.9740
35	2.0612	2.7662	.9974	.9438	1.0596	.9801
36	2.1349	2.7994	.9981	.9568	1.0451	.9850
37	2.2035	2.8266	.9971	.9693	1.0317	.9882
38	2.2441	2.8405	.9991	.9732	1.0276	.9911
39	2.3051	2.8599	1.0001	.9804	1.0200	.9942
40	2.3609	2.8711	.9987	.9866	1.0136	.9949
* 41	2.4854	2.8915	1.0003	.9938	1.0063	.9984
** 42	2.7115	2.9053	1.0000	1.0000	1.0000	1.0000
43	2.9045	2.9095	1.0001	1.0017	.9983	1.0006
44	3.0975	2.9108	1.0001	1.0022	.9978	1.0008
45	3.3414	2.9135	.9996	1.0039	.9961	1.0009
46	3.5344	2.9141	1.0002	1.0036	.9964	1.0012
47	3.7122	2.9122	1.0007	1.0022	.9978	1.0013
48	3.9510	2.9086	.9995	1.0014	.9981	1.0002
49	4.1135	2.9047	1.0006	.9992	1.0008	1.0002
50	4.2939	2.9038	1.0006	.9988	1.0012	1.0001

NSWC TR 79-153

TABLE A-3 BOUNDARY LAYER PROFILE LISTING
 RUN NO 711281 CONT.

N	Y (CM)	M	TT/TTE	D/DE	T/TE	U/UE
51	4.4082	2.9024	.9994	.9994	1.0006	.9993
52	4.5453	2.9000	1.0005	.9972	1.0028	.9996
53	4.7231	2.8986	1.0004	.9967	1.0033	.9994
54	4.9009	2.8986	.9999	.9972	1.0028	.9991
55	5.1397	2.8955	.9998	.9960	1.0040	.9986
56	5.2921	2.8946	.9998	.9956	1.0044	.9985
57	5.4750	2.8927	1.0003	.9942	1.0058	.9985
58	5.6452	2.8912	1.0003	.9937	1.0064	.9983
59	5.7899	2.8936	.9997	.9952	1.0048	.9984
60	5.8992	2.8962	1.0004	.9957	1.0043	.9990
61	5.9804	2.8963	1.0016	.9946	1.0054	.9996
62	6.0643	2.8983	1.0016	.9954	1.0046	.9999
63	6.1532	2.8974	1.0010	.9956	1.0044	.9995
64	6.2649	2.8983	.9999	.9971	1.0029	.9990
65	6.3691	2.8996	1.0011	.9965	1.0036	.9998
66	6.4681	2.8986	1.0010	.9961	1.0039	.9997
67	6.4249	2.9014	.9999	.9984	1.0016	.9995
68	6.6002	2.9017	.9994	.9991	1.0009	.9992
69	6.7323	2.9024	.9994	.9994	1.0006	.9993
70	7.0752	2.9042	.9976	1.0019	.9981	.9987
71	7.3216	2.9043	.9977	1.0019	.9981	.9987

NSKC TR 79-153

TABLE A-3 BOUNDARY LAYER PROFILE LISTING
RUN NO 712014

X = 1.981E+00 M	ME = 2.936E+00	DEL = 2.432E+00 CM
PU = 1.038E+05 N/M2	DE = 9.422E-02 KG/M3	DSTR = 8.039E-01 CM
TO = 3.202E+02 DEG.K	TE = 1.175E+02 DEG.K	TH = 1.633E-01 CM
PSW = 3.155E+03 N/M2	UE = 6.381E+02 M/S	THE = 2.941E-01 CM
TW = 2.973E+02 N/M2	RE = 7.373E+06 1/M	THH = 1.444E-02 CM
TAUW = 2.504E+01 N/M2	CF = 1.307E-03	RETH = 3.055E+04
K = 0. CM	MDOT = 0. KG/M2*S	

N	Y (CM)	M	TT/TTE	D/DE	T/TTE	U/UE
1	0.0000	0.0000	.9286	.3954	2.5294	0.0000
2	.0064	.5009	.9354	.4122	2.4263	.2658
3	.0140	.6188	.9388	.4210	2.3754	.3249
4	.0165	.7193	.9415	.4303	2.3240	.3735
5	.0241	.8808	.9469	.4478	2.2329	.4483
6	.0318	.9939	.9511	.4622	2.1635	.4979
7	.0394	1.0830	.9530	.4756	2.1026	.5349
8	.0445	1.1224	.9549	.4813	2.0776	.5510
9	.0521	1.1649	.9585	.4869	2.0536	.5686
10	.0572	1.2014	.9580	.4938	2.0251	.5823
11	.0572	1.2023	.9598	.4931	2.0281	.5832
12	.0673	1.2423	.9617	.4995	2.0019	.5987
13	.0749	1.2624	.9624	.5030	1.9879	.6063
14	.0851	1.2959	.9624	.5096	1.9625	.6183
15	.1130	1.3560	.9651	.5203	1.9220	.6403
16	.1334	1.3875	.9667	.5260	1.9012	.6516
17	.1537	1.4252	.9674	.5336	1.8740	.6645
18	.1867	1.4674	.9695	.5417	1.8459	.6790
19	.2096	1.4933	.9709	.5467	1.8291	.6879
20	.2299	1.5163	.9723	.5512	1.8142	.6956
21	.2578	1.5473	.9751	.5568	1.7961	.7063
22	.3086	1.5980	.9762	.5681	1.7602	.7221
23	.3340	1.6207	.9770	.5732	1.7447	.7291
24	.3620	1.6497	.9779	.5797	1.7250	.7360
25	.3975	1.6707	.9792	.5842	1.7117	.7445
26	.4280	1.6998	.9802	.5910	1.6921	.7531
27	.4610	1.7245	.9804	.5972	1.6745	.7601
28	.5017	1.7576	.9797	.6062	1.6496	.7689
29	.5296	1.7765	.9792	.6116	1.6352	.7737
30	.5779	1.8118	.9791	.6211	1.6101	.7830
31	.6337	1.8565	.9794	.6332	1.5792	.7946
32	.6795	1.8878	.9781	.6429	1.5555	.8019
33	.7125	1.9090	.9781	.6489	1.5412	.8072
34	.7734	1.9547	.9790	.6616	1.5115	.8186
35	.8598	2.0155	.9808	.6784	1.4740	.8335
36	.9487	2.0748	.9825	.6954	1.4381	.8475
37	1.0554	2.1547	.9836	.7198	1.3893	.8651
38	1.1595	2.2239	.9856	.7409	1.3496	.8800
39	1.2383	2.2813	.9871	.7590	1.3175	.8919
40	1.3399	2.3466	.9900	.7792	1.2834	.9054
41	1.4389	2.4174	.9930	.8018	1.2472	.9195
42	1.5304	2.4782	.9928	.8240	1.2136	.9299
43	1.5761	2.5077	.9947	.8333	1.2001	.9357
44	1.6091	2.5274	.9951	.8402	1.1902	.9391
45	1.6624	2.5690	.9961	.8550	1.1696	.9463
46	1.6853	2.5952	.9979	.8634	1.1582	.9513
47	1.7488	2.6352	.9988	.8780	1.1390	.9579
48	1.8123	2.6760	.9992	.8936	1.1190	.9642
49	1.8707	2.7164	1.0019	.9072	1.1023	.9714
50	1.9291	2.7434	1.0019	.9180	1.0893	.9753

NSWC TR 79-153

TABLE A-3 BOUNDARY LAYER PROFILE LISTING
RUN NO 712014 CONT.

N	Y (CM)	M	TT/TTE	D/DE	T/TE	U/UE
51	1.9723	2.7670	1.0030	.9265	1.0793	.9791
52	2.0155	2.7880	1.0046	.9335	1.0712	.9828
53	2.0460	2.8050	1.0044	.9407	1.0631	.9850
54	2.0765	2.8162	1.0040	.9457	1.0575	.9864
55	2.1044	2.8330	1.0067	.9500	1.0526	.9900
56	2.1298	2.8439	1.0070	.9543	1.0479	.9916
57	2.1552	2.8547	1.0066	.9591	1.0426	.9928
58	2.1552	2.8621	1.0032	.9655	1.0357	.9921
59	2.1882	2.8676	.9998	.9711	1.0298	.9911
60	2.2162	2.8729	.9999	.9732	1.0275	.9919
61	2.2517	2.8822	.9983	.9787	1.0218	.9923
62	2.2873	2.8942	.9991	.9830	1.0173	.9943
63	2.3457	2.9084	.9982	.9899	1.0102	.9956
64	2.3889	2.9171	.9996	.9923	1.0078	.9974
* 65	2.4321	2.9225	.9997	.9945	1.0055	.9982
66	2.4651	2.9250	1.0003	.9950	1.0051	.9988
** 67	2.5616	2.9360	1.0000	1.0000	1.0000	1.0000
68	2.6505	2.9392	1.0000	1.0013	.9987	1.0004
69	2.7648	2.9433	1.0007	1.0024	.9976	1.0013
70	2.8867	2.9455	1.0013	1.0028	.9972	1.0019
71	2.9858	2.9466	1.0014	1.0032	.9968	1.0020
72	3.0772	2.9482	1.0020	1.0033	.9967	1.0025
73	3.3363	2.9493	1.0014	1.0044	.9957	1.0024
74	3.6919	2.9473	1.0014	1.0035	.9965	1.0021
75	3.9738	2.9435	1.0019	1.0013	.9987	1.0019
76	4.2278	2.9391	1.0024	.9990	1.0010	1.0016
77	4.6038	2.9351	1.0023	.9973	1.0027	1.0011
78	4.8933	2.9325	1.0023	.9963	1.0037	1.0007
79	5.0914	2.9307	1.0016	.9961	1.0039	1.0002
80	5.4597	2.9267	1.0021	.9939	1.0062	.9999
81	5.7925	2.9295	1.0016	.9956	1.0044	1.0000
82	6.1252	2.9349	1.0011	.9984	1.0016	1.0004
83	6.5037	2.9390	1.0018	.9995	1.0005	1.0013
84	6.8517	2.9394	1.0030	.9985	1.0015	1.0019
85	7.1488	2.9392	1.0042	.9972	1.0028	1.0025
86	7.5781	2.9389	1.0030	.9983	1.0017	1.0019
87	7.8981	2.9393	1.0029	.9985	1.0015	1.0019
88	8.2283	2.9433	1.0025	1.0007	.9993	1.0022
89	8.5458	2.9385	1.0042	.9969	1.0031	1.0024
90	8.8354	2.9242	1.0044	.9905	1.0096	1.0007
91	9.0691	2.9164	1.0049	.9868	1.0134	1.0000
92	9.2291	2.9259	1.0051	.9906	1.0094	1.0013
93	9.4933	2.9394	1.0059	.9956	1.0045	1.0034

NSWC TR 79-153

TABLE A-3 BOUNDARY LAYER PROFILE LISTING
RUN NO 712015

X = 1.981E+00 M	ME = 2.928E+00	DFI = 2.910E+00 CM
PO = 5.295E+04 N/M2	DE = 4.799E-02 KG/M3	DSTR = 9.344E-01 CM
TO = 3.208E+02 DEG.K	TE = 1.182E+02 DEG.K	TH = 1.908E-01 CM
PSW = 1.625E+03 N/M2	UE = 6.380E+02 M/S	THE = 3.421E-01 CM
TW = 2.969E+02 N/M2	RE = 3.736E+06 1/M	THH = 2.076E-02 CM
TAUW = 1.413E+01 N/M2	CF = 1.448E-03	RFTH = 1.809E+04
K = 0. CM	MDOT = 0. KG/M2*s	

N	Y (CM)	M	TT/TIE	D/DE	T/TIE	U/UIE
1	0.0000	0.0000	.9257	.3979	2.5132	0.0000
2	.0064	.3653	.9302	.4066	2.4597	.1956
3	.0064	.3641	.9323	.4055	2.4658	.1953
4	.0114	.4253	.9352	.4081	2.4504	.2274
5	.0165	.5103	.9388	.4128	2.4225	.2712
6	.0165	.5128	.9405	.4122	2.4257	.2728
7	.0241	.6778	.9449	.4257	2.3493	.3548
8	.0318	.7888	.9476	.4371	2.2879	.4075
9	.0394	.8754	.9498	.4473	2.2359	.4470
10	.0445	.9659	.9527	.4588	2.1798	.4870
11	.0546	1.0438	.9548	.4698	2.1284	.5200
12	.0622	1.1035	.9563	.4790	2.0878	.5445
13	.0673	1.1435	.9566	.4858	2.0587	.5603
14	.0775	1.1809	.9572	.4921	2.0321	.5749
15	.0876	1.2092	.9582	.4968	2.0129	.5858
16	.0953	1.2334	.9585	.5012	1.9952	.5949
17	.1054	1.2658	.9591	.5071	1.9719	.6070
18	.1156	1.2817	.9591	.5102	1.9598	.6128
19	.1791	1.3905	.9595	.5323	1.8785	.6508
20	.2121	1.4239	.9601	.5392	1.8545	.6622
21	.2527	1.4638	.9620	.5470	1.8283	.6759
22	.3061	1.5151	.9632	.5580	1.7922	.6927
23	.3518	1.5533	.9634	.5668	1.7642	.7046
24	.4001	1.5851	.9645	.5738	1.7427	.7146
25	.4407	1.6162	.9655	.5808	1.7218	.7242
26	.4763	1.6458	.9665	.5876	1.7020	.7333
27	.5220	1.6798	.9665	.5962	1.6774	.7430
28	.5525	1.6999	.9672	.6009	1.6641	.7489
29	.5855	1.7214	.9685	.6057	1.6509	.7553
30	.6261	1.7518	.9700	.6128	1.6319	.7642
31	.6845	1.7880	.9718	.6214	1.6093	.7746
32	.7404	1.8288	.9742	.6310	1.5849	.7862
33	.7988	1.8633	.9765	.6391	1.5646	.7959
34	.8471	1.8903	.9779	.6458	1.5484	.8033
35	.9081	1.9310	.9803	.6559	1.5246	.8142
36	.9589	1.9647	.9820	.6647	1.5044	.8230
37	1.0071	1.9956	.9841	.6724	1.4871	.8311
38	1.0833	2.0465	.9856	.6868	1.4561	.8433
39	1.1214	2.0668	.9867	.6922	1.4447	.8483
40	1.1214	2.0672	.9891	.6907	1.4478	.8495
41	1.1621	2.0896	.9903	.6967	1.4353	.8549
42	1.1951	2.1151	.9917	.7038	1.4209	.8610
43	1.2306	2.1389	.9918	.7112	1.4061	.8661
44	1.2586	2.1550	.9917	.7164	1.3958	.8695
45	1.2941	2.1775	.9917	.7236	1.3820	.8742
46	1.3348	2.2018	.9919	.7314	1.3672	.8792
47	1.3703	2.2259	.9920	.7393	1.3527	.8841
48	1.4059	2.2487	.9926	.7464	1.3398	.8889
49	1.4338	2.2666	.9931	.7520	1.3298	.8926
50	1.4669	2.2907	.9937	.7596	1.3164	.8975

NSWC TR 79-153

TABLE A-3 BOUNDARY LAYER PROFILE LISTING
RUN NO 712015 CONT.

N	Y (CM)	M	TT/TTE	D/DE	T/TE	U/UE
51	1.5075	2.3109	.9937	.7666	1.3045	.9014
52	1.5507	2.3425	.9940	.7773	1.2865	.9074
53	1.5964	2.3694	.9935	.7870	1.2706	.9121
54	1.6396	2.3956	.9936	.7962	1.2560	.9169
55	1.6726	2.4255	.9932	.8072	1.2389	.9219
56	1.6726	2.4259	.9932	.8073	1.2387	.9220
57	1.7005	2.4459	.9937	.8142	1.2283	.9257
58	1.7336	2.4674	.9937	.8220	1.2165	.9294
59	1.7666	2.4865	.9936	.8291	1.2061	.9326
60	1.8072	2.5135	.9937	.8390	1.1918	.9371
61	1.8453	2.5355	.9930	.8478	1.1795	.9404
62	1.8783	2.5549	.9935	.8548	1.1699	.9437
63	1.9012	2.5636	.9937	.8579	1.1656	.9452
64	1.9266	2.5817	.9941	.8644	1.1568	.9483
65	2.0028	2.6292	.9935	.8833	1.1321	.9553
66	2.0942	2.6833	.9942	.9040	1.1062	.9638
67	2.1857	2.7314	.9953	.9223	1.0842	.9713
68	2.2593	2.7677	.9955	.9369	1.0674	.9765
69	2.3940	2.8275	.9967	.9604	1.0412	.9853
70	2.5667	2.8842	.9979	.9832	1.0171	.9934
71	2.7191	2.9121	.9991	.9940	1.0061	.9975
* 72	2.9096	2.9282	1.0000	1.0000	1.0000	1.0000
73	3.1331	2.9324	1.0007	1.0011	.9989	1.0009
74	3.2957	2.9340	1.0007	1.0018	.9982	1.0011
75	3.4252	2.9327	1.0013	1.0006	.9994	1.0012
76	3.5598	2.9361	1.0019	1.0015	.9985	1.0019
77	3.6843	2.9358	1.0031	1.0002	.9998	1.0025
78	3.8240	2.9375	1.0043	.9997	1.0003	1.0033
79	3.9434	2.9365	1.0055	.9981	1.0019	1.0038
80	4.0678	2.9361	1.0055	.9979	1.0021	1.0037
81	4.1897	2.9360	1.0060	.9973	1.0027	1.0040
82	4.3218	2.9350	1.0060	.9969	1.0031	1.0039
83	4.4260	2.9353	1.0060	.9970	1.0030	1.0039
84	4.5707	2.9320	1.0072	.9945	1.0055	1.0041
85	4.6723	2.9311	1.0077	.9936	1.0065	1.0042
86	4.8044	2.9259	1.0082	.9909	1.0092	1.0038
87	4.9086	2.9239	1.0082	.9900	1.0101	1.0035
88	5.0279	2.9233	1.0082	.9898	1.0103	1.0035
89	5.2692	2.9210	1.0087	.9882	1.0119	1.0034
90	5.3912	2.9193	1.0081	.9882	1.0120	1.0029
91	5.8357	2.9183	1.0075	.9883	1.0118	1.0025
92	6.2522	2.9229	1.0076	.9902	1.0099	1.0031
93	6.6688	2.9239	1.0070	.9912	1.0089	1.0029
94	7.1184	2.9239	1.0064	.9918	1.0083	1.0026

NSWC TR 79-153

TABLE A-3 BOUNDARY LAYER PROFILE LISTING
RUN NO 712016

X = 1.981E+00 M ME = 2.870E+00 DEL = 3.631E+00 CM
 PO = 1.544E+04 N/M2 DE = 1.363E-02 KG/M3 DSTR = 1.192E+00 CM
 TO = 3.212E+02 DEG.K TE = 1.213E+02 DEG.K TH = 2.483E-01 CM
 PSW = 4.932E+02 N/M2 UE = 6.337E+02 M/S THE = 4.431E-01 CM
 TW = 2.968E+02 N/M2 RE = 1.027E+06 1/M THH = 3.252E-02 CM
 TAUW = 5.055E+00 N/M2 CF = 1.849E-03 RETH = 6.469E+03
 K = 0. CM MDOT = 0. KG/M2*S

N	Y (CM)	M	TT/TTE	D/DE	T/TE	U/UE
1	0.0000	0.0000	.9239	.4088	2.4464	0.0000
2	.0064	.1520	.9253	.4100	2.4387	.0827
3	.0241	.2706	.9270	.4134	2.4192	.1466
4	.0419	.4257	.9301	.4208	2.3765	.2286
5	.0597	.5923	.9337	.4329	2.3103	.3136
6	.0724	.7151	.9367	.4444	2.2501	.3737
7	.1003	.8991	.9426	.4655	2.1484	.4591
8	.1156	.9898	.9451	.4779	2.0924	.4988
9	.1384	1.0872	.9485	.4923	2.0312	.5398
10	.1562	1.1552	.9509	.5032	1.9873	.5674
11	.1740	1.1909	.9515	.5095	1.9627	.5812
12	.2121	1.2739	.9545	.5241	1.9081	.6130
13	.2527	1.3454	.9570	.5375	1.8605	.6393
14	.2781	1.3724	.9580	.5427	1.8425	.6490
15	.2934	1.3839	.9578	.5453	1.8338	.6529
16	.3112	1.4088	.9587	.5503	1.8172	.6616
17	.3289	1.4260	.9593	.5538	1.8058	.6676
18	.4128	1.4962	.9618	.5685	1.7591	.6914
19	.4839	1.5356	.9632	.5770	1.7331	.7043
20	.5575	1.5850	.9649	.5881	1.7005	.7201
21	.6439	1.6394	.9668	.6006	1.6649	.7370
22	.8395	1.7331	.9694	.6237	1.6034	.7646
23	.9335	1.7725	.9707	.6335	1.5785	.7758
24	1.0401	1.8339	.9728	.6494	1.5399	.7928
25	1.2332	1.9485	.9764	.6805	1.4696	.8229
26	1.4643	2.0580	.9798	.7120	1.4045	.8497
27	1.6624	2.1506	.9826	.7399	1.3515	.8710
28	1.8504	2.2509	.9848	.7721	1.2952	.8925
29	2.0892	2.3634	.9879	.8093	1.2356	.9152
30	2.3736	2.5053	.9916	.8590	1.1642	.9417
31	2.6454	2.6142	.9943	.8990	1.1123	.9605
32	2.9045	2.7206	.9967	.9398	1.0640	.9777
33	3.2093	2.8061	.9986	.9738	1.0269	.9907
34	3.3642	2.8394	.9993	.9873	1.0129	.9956
* 35	3.6309	2.8605	.9998	.9959	1.0041	.9986
** 36	3.9103	2.8704	1.0000	1.0000	1.0000	1.0000
37	4.1008	2.8704	1.0000	1.0000	1.0000	1.0000
38	4.2456	2.8712	1.0000	1.0003	.9997	1.0001
39	4.5453	2.8727	1.0000	1.0009	.9991	1.0003
40	4.9543	2.8755	1.0001	1.0021	.9979	1.0007
41	5.5182	2.8702	1.0006	.9993	1.0007	1.0003
42	5.7823	2.8709	1.0006	.9996	1.0004	1.0004
43	6.0414	2.8685	1.0000	.9992	1.0008	.9997
44	6.2776	2.8649	.9999	.9978	1.0023	.9992
45	6.5138	2.8685	1.0000	.9992	1.0008	.9997
46	6.7805	2.8660	1.0005	.9976	1.0024	.9997
47	7.0853	2.8645	1.0011	.9964	1.0036	.9998
48	7.2860	2.8591	1.0009	.9942	1.0059	.9990
49	7.6924	2.8615	1.0004	.9958	1.0043	.9990
50	8.2182	2.8601	1.0010	.9946	1.0054	.9991

NSWC TR 79-153

TABLE A-3 BOUNDARY LAYER PROFILE LISTING
RUN NO 801261

X = 1.981E+00 M	ME = 2.952E+00	DEL = 2.587E+00 CM
PO = 4.134E+05 N/M2	DE = 3.789E-01 KG/M3	DSTR = 7.298E-01 CM
TO = 3.154E+02 DEG.K	TE = 1.150E+02 DEG.K	TH = 1.471E-01 CM
PSW = 1.236E+04 N/M2	UE = 6.345E+02 M/S	THE = 2.669E-01 CM
TW = 2.967E+02 N/M2	RE = 3.014E+07 1/M	THH = 9.855E-03 CM
TAUW = 1.081E+02 N/M2	CF = 1.419E-03	RETH = 1.125E+05
K = 1.016E-02 CM	MDOT = 0.	KG/M2*S

N	Y (CM)	M	TT/TTE	D/DE	T/TE	U/UE
1	0.0000	0.0000	.9410	.3874	2.5811	0.0000
2	.0064	.9057	.9583	.4429	2.2581	.4610
3	.0114	.9242	.9588	.4452	2.2463	.4692
4	.0165	.9649	.9583	.4513	2.2160	.4866
5	.0241	1.0189	.9594	.4589	2.1793	.5095
6	.0267	1.0650	.9609	.4654	2.1485	.5288
7	.0318	1.1110	.9625	.4723	2.1174	.5476
8	.0343	1.1244	.9629	.4743	2.1082	.5530
9	.0343	1.1266	.9630	.4747	2.1067	.5539
10	.0419	1.1790	.9641	.4833	2.0693	.5745
11	.1130	1.4475	.9713	.5326	1.8776	.6719
12	.2019	1.5803	.9752	.5606	1.7839	.7150
13	.2781	1.6577	.9777	.5778	1.7307	.7387
14	.3645	1.7327	.9795	.5957	1.6788	.7605
15	.4686	1.8073	.9807	.6146	1.6271	.7809
16	.5779	1.8909	.9833	.6359	1.5726	.8032
17	.6922	1.9816	.9854	.6605	1.5139	.8259
18	.7861	2.0573	.9870	.6820	1.4662	.8438
19	.8776	2.1188	.9881	.7002	1.4281	.8577
20	1.0020	2.2148	.9902	.7294	1.3710	.8784
21	1.0884	2.2823	.9908	.7513	1.3310	.8919
22	1.2383	2.3927	.9936	.7870	1.2706	.9136
23	1.3526	2.4817	.9964	.8165	1.2247	.9303
24	1.4491	2.5546	.9975	.8425	1.1869	.9428
25	1.5939	2.6540	.9980	.8799	1.1365	.9584
26	1.7310	2.7359	.9992	.9110	1.0977	.9709
27	1.9317	2.8249	1.0011	.9454	1.0577	.9841
28	2.1628	2.8963	1.0025	.9737	1.0270	.9942
29	2.3406	2.9209	1.0018	.9848	1.0154	.9970
* 30	2.5870	2.9416	1.0016	.9939	1.0061	.9995
** 31	2.7394	2.9521	1.0000	1.0000	1.0000	1.0000
32	2.9731	2.9519	.9994	1.0005	.9995	.9997
33	3.2271	2.9251	.9995	.9889	1.0112	.9964
34	3.5319	2.9271	.9995	.9898	1.0103	.9966
35	3.8799	2.9349	.9985	.9941	1.0059	.9971
36	4.2939	2.9312	.9972	.9938	1.0062	.9960
37	4.5555	2.9200	.9964	.9898	1.0103	.9942
38	4.8628	2.9158	.9951	.9893	1.0108	.9930
39	5.0381	2.9142	.9951	.9887	1.0114	.9928
40	5.3353	2.9251	.9941	.9943	1.0057	.9937
41	5.5817	2.9371	.9943	.9992	1.0008	.9953
42	5.7341	2.9403	.9937	1.0012	.9988	.9954
43	5.8661	2.9380	.9931	1.0008	.9992	.9948

NSWC TR 79-153

TABLE A-3 BOUNDARY LAYER PROFILE LISTING
RUN NO 801251

X = 1.981E+00 M ME = 2.963E+00 DEL = 2.783E+00 CM
 PO = 2.049E+05 N/M2 DE = 1.911E-01 KG/M3 DSTP = 8.169E-01 CM
 TU = 3.158E+02 DEG.K TE = 1.146E+02 DEG.K TH = 1.595E-01 CM
 PSW = 6.232E+03 N/M2 UE = 6.358E+02 M/S THE = 2.875E-01 CM
 TW = 2.938E+02 N/M2 RE = 1.527E+07 1/M THH = 6.385E-03 CM
 TAUW = 5.054E+01 N/M2 CF = 1.310E-03 RETH = 6.185E+04
 K = 1.016E-02 CM MDOT = 0. KG/M2*CS

N	Y (CM)	M	TT/TTE	D/DE	T/TE	U/UE
1	0.0000	0.0000	.9301	.3902	2.5630	0.0000
2	.0064	.7466	.9307	.4334	2.3075	.3828
3	.0114	.8052	.9330	.4394	2.2759	.4100
4	.0165	.9194	.9379	.4523	2.2108	.4614
5	.0165	.9200	.9390	.4519	2.2130	.4619
6	.0318	1.0671	.9478	.4701	2.1273	.5253
7	.0394	1.1116	.9459	.4785	2.0900	.5424
8	.0622	1.2279	.9575	.4933	2.0273	.5901
9	.0851	1.2987	.9556	.5079	1.9691	.6151
10	.1156	1.3667	.9639	.5171	1.9338	.6415
11	.1257	1.3945	.9592	.5255	1.9030	.6493
12	.1537	1.4194	.9677	.5261	1.9007	.6605
13	.1664	1.4606	.9632	.5375	1.8605	.6724
14	.2096	1.5001	.9672	.5441	1.8379	.6864
15	.2121	1.5138	.9627	.5497	1.8192	.6891
16	.2578	1.5576	.9679	.5569	1.7958	.7045
17	.2781	1.5801	.9676	.5623	1.7783	.7112
18	.4077	1.6819	.9747	.5829	1.7155	.7435
19	.4788	1.7373	.9769	.5957	1.6787	.7597
20	.5550	1.7896	.9796	.6078	1.6454	.7748
21	.6414	1.8606	.9839	.6242	1.6021	.7948
22	.7150	1.9150	.9850	.6387	1.5658	.8088
23	.8115	1.9849	.9878	.6568	1.5225	.8266
24	.9030	2.0544	.9912	.6752	1.4811	.8439
25	1.0147	2.1407	.9935	.7000	1.4286	.8636
26	1.1367	2.2372	.9963	.7289	1.3720	.8845
27	1.2103	2.2990	.9991	.7471	1.3384	.8977
28	1.3195	2.3751	1.0003	.7721	1.2952	.9123
29	1.4186	2.4469	1.0009	.7968	1.2551	.9252
30	1.5380	2.5269	1.0024	.8243	1.2131	.9394
31	1.6345	2.5934	1.0029	.8485	1.1785	.9502
32	1.7717	2.6640	1.0049	.8737	1.1445	.9619
33	1.8758	2.7285	1.0051	.8986	1.1128	.9715
34	2.0079	2.7926	1.0060	.9234	1.0830	.9809
35	2.2035	2.8821	1.0043	.9617	1.0399	.9920
36	2.5057	2.9402	1.0011	.9892	1.0109	.9978
* 37	2.7826	2.9628	1.0000	1.0000	1.0000	1.0000
38	3.0188	2.9698	.9988	1.0042	.9958	1.0003
39	3.1483	2.9576	.9992	.9986	1.0014	.9990
40	3.9205	2.9438	1.0016	.9903	1.0098	.9985
41	4.3040	2.9390	1.0022	.9877	1.0125	.9981
42	4.7308	2.9250	1.0023	.9815	1.0188	.9965
43	5.2870	2.9317	1.0051	.9817	1.0186	.9987
44	5.7468	2.9419	1.0066	.9845	1.0157	1.0007
45	5.9677	2.9376	1.0062	.9831	1.0172	1.0000
46	6.5215	2.9249	1.0076	.9764	1.0242	.9991
47	6.9202	2.9488	1.0093	.9848	1.0154	1.0029

NSWC TR 79-153

TABLE A-3 BOUNDARY LAYER PROFILE LISTING
RUN NO 801252

X = 1.981E+00 M ME = 2.944E+00 DEL = 2.590E+00 CM
 PO = 1.040E+05 N/M2 DE = 9.631E-02 KG/M3 DSTP = 8.836E-01 CM
 TO = 3.137E+02 DEG.K TE = 1.148E+02 DEG.K TH = 1.743E-01 CM
 PSW = 3.161E+03 N/M2 UE = 6.322E+02 M/S THE = 3.116E-01 CM
 TW = 2.932E+02 N/M2 RE = 7.645E+06 1/M THH = 1.168E-02 CM
 TAUW = 2.544E+01 N/M2 CF = 1.323E-03 RETH = 3.382E+04
 K = 1.016E-02 CM MDOT = 0. KG/M2*S

N	Y(CM)	M	TT/TTE	D/DE	T/TE	U/UE
1	0.0000	0.0000	.9348	.3914	2.5548	0.0000
2	.0064	.5688	.9240	.4216	2.3719	.2976
3	.0140	.6648	.9246	.4307	2.3218	.3441
4	.0191	.7571	.9272	.4399	2.2735	.3878
5	.0267	.8549	.9304	.4507	2.2188	.4326
6	.0343	.9296	.9330	.4599	2.1743	.4656
7	.0394	.9170	.9331	.4581	2.1832	.4603
8	.0572	1.0952	.9397	.4828	2.0714	.5355
9	.0572	1.0959	.9397	.4829	2.0710	.5357
10	.0673	1.1545	.9433	.4913	2.0356	.5595
11	.1207	1.2931	.9516	.5131	1.9490	.6133
12	.1537	1.3490	.9534	.5234	1.9105	.6334
13	.1867	1.3967	.9572	.5314	1.8819	.6509
14	.2223	1.4338	.9588	.5385	1.8570	.6637
15	.2604	1.4777	.9607	.5472	1.8275	.6786
16	.3035	1.5121	.9638	.5532	1.8077	.6906
17	.3467	1.5500	.9660	.5607	1.7833	.7031
18	.4255	1.6108	.9698	.5730	1.7451	.7228
19	.5245	1.6879	.9745	.5894	1.6967	.7469
20	.6236	1.7571	.9781	.6050	1.6528	.7674
21	.6871	1.8121	.9801	.6185	1.6169	.7827
22	.7861	1.8802	.9819	.6361	1.5721	.8009
23	.8903	1.9581	.9854	.6560	1.5244	.8213
24	1.0020	2.0341	.9889	.6761	1.4790	.8403
25	1.1544	2.1507	.9921	.7100	1.4085	.8671
26	1.2637	2.2277	.9948	.7328	1.3645	.8840
27	1.3856	2.3199	.9968	.7622	1.3120	.9027
28	1.4948	2.4017	.9997	.7882	1.2687	.9189
29	1.5913	2.4615	1.0004	.8089	1.2362	.9297
30	1.7082	2.5348	1.0017	.8347	1.1981	.9425
31	1.7971	2.5872	1.0020	.8540	1.1710	.9511
32	1.8961	2.6465	1.0021	.8766	1.1408	.9602
33	1.9799	2.6981	1.0034	.8956	1.1166	.9685
34	2.0561	2.7469	1.0031	.9152	1.0927	.9754
35	2.1654	2.8070	1.0025	.9402	1.0637	.9834
36	2.2797	2.8635	1.0020	.9640	1.0374	.9907
37	2.3762	2.8973	1.0009	.9793	1.0212	.9946
38	2.4727	2.9219	1.0008	.9899	1.0102	.9976
* 39	2.5895	2.9438	1.0000	1.0000	1.0000	1.0000
40	2.7292	2.9600	1.0000	1.0071	.9930	1.0020
41	2.8512	2.9697	.9991	1.0122	.9880	1.0027
42	2.9680	2.9775	.9988	1.0159	.9844	1.0035
43	3.0721	2.9776	.9998	1.0149	.9853	1.0040
44	3.2245	2.9670	.9990	1.0110	.9891	1.0024
45	3.3846	2.9518	.9990	1.0045	.9955	1.0005
46	3.5192	2.9493	.9995	1.0029	.9971	1.0004
47	3.6894	2.9528	.9997	1.0042	.9959	1.0010
48	3.8545	2.9537	1.0003	1.0040	.9961	1.0014
49	3.9815	2.9513	.9991	1.0042	.9958	1.0005
50	4.1567	2.9495	.9999	1.0025	.9975	1.0007

NSWC TR 79-153

TABLE A-3 BOUNDARY LAYER PROFILE LISTING
RUN NO 801253

X = 1.981E+00 M ME = 2.964E+00 DEL = 3.194E+00 CM
 PO = 5.206E+04 N/M2 DE = 4.967E-02 KG/M3 DSTP = 1.024E+00 CM
 TO = 3.149E+02 DEG.K TE = 1.142E+02 DEG.K TH = 1.993E-01 CM
 PSW = 1.600E+03 N/M2 UE = 6.350E+02 M/S THE = 3.551E-01 CM
 TW = 2.946E+02 N/M2 RE = 3.979E+06 1/M THH = 1.366E-02 CM
 TAUW = 1.419E+01 N/M2 CF = 1.418E-03 RETH = 2.013E+04
 K = 1.016E-02 CM MDOT = 0. KG/M2*S

N	Y (CM)	M	TT/TTE	D/DE	T/TE	U/UE
1	0.0000	0.0000	.9356	.3876	2.5798	0.0000
2	.0064	.5061	.9302	.4098	2.4400	.2667
3	.0089	.5765	.9299	.4159	2.4043	.3015
4	.0267	.7413	.9294	.4331	2.3089	.3800
5	.0419	.9058	.9324	.4528	2.2085	.4541
6	.0597	1.0466	.9357	.4725	2.1163	.5137
7	.0749	1.1214	.9379	.4839	2.0665	.5438
8	.0978	1.1864	.9409	.4940	2.0245	.5695
9	.1511	1.2888	.9457	.5109	1.9574	.6083
10	.1918	1.3463	.9511	.5195	1.9248	.6301
11	.1918	1.3537	.9518	.5207	1.9206	.6329
12	.2705	1.4412	.9559	.5370	1.8622	.6635
13	.3594	1.5124	.9607	.5502	1.8174	.6878
14	.4509	1.5688	.9631	.5619	1.7796	.7060
15	.5931	1.6743	.9685	.5844	1.7112	.7389
16	.7633	1.7846	.9754	.6086	1.6430	.7717
17	.9970	1.9476	.9821	.6494	1.5398	.8153
18	1.2433	2.1135	.9895	.6940	1.4410	.8559
19	1.4821	2.2711	.9958	.7399	1.3515	.8907
20	1.6853	2.3881	.9992	.7769	1.2871	.9140
21	1.9393	2.5392	1.0019	.8287	1.2066	.9410
22	2.3787	2.7873	1.0044	.9221	1.0845	.9792
23	2.6581	2.8949	1.0034	.9672	1.0339	.9930
24	2.9223	2.9453	1.0012	.9907	1.0094	.9983
* 25	3.1941	2.9642	1.0000	1.0000	1.0000	1.0000
26	3.4938	2.9519	.9990	.9957	1.0044	.9980
27	3.8189	2.9476	.9983	.9945	1.0055	.9971
28	4.1161	2.9445	.9996	.9919	1.0081	.9974
29	4.4158	2.9387	.9984	.9906	1.0095	.9961
30	4.8552	2.9258	.9999	.9837	1.0166	.9952
31	4.9492	2.8908	1.0006	.9682	1.0328	.9911
32	5.0406	2.9139	1.0008	.9777	1.0228	.9942

NSWC TR 79-153

TABLE A-3 BOUNDARY LAYER PROFILE LISTING
RUN NO 801262

X = 1.981E+00 M	ME = 2.944E+00	DEL = 2.457E+00 CM
PO = 4.098E+05 N/M2	DE = 3.695E-01 KG/M3	DSTK = 7.289E-01 CM
TO = 3.196E+02 DEG.K	TE = 1.170E+02 DEG.K	TH = 1.509E-01 CM
PSW = 1.225E+04 N/M2	UE = 6.381E+02 M/S	THE = 2.735E-01 CM
TW = 2.973E+02 N/M2	RE = 2.905E+07 1/M	THH = 1.548E-02 CM
TAUW = 9.944E+01 N/M2	CF = 1.323E-03	KETH = 1.113E+05
K = 1.016E-02 CM	MDOT = 1.465E-02 KG/M2* S	

N	Y (CM)	M	TT/TTE	D/DE	T/TE	U/UE
1	0.0000	0.0000	.9302	.3934	2.5421	0.0000
2	.0064	.9096	.9476	.4501	2.2219	.4606
3	.0114	.9487	.9488	.4551	2.1973	.4778
4	.0191	1.0051	.9489	.4636	2.1572	.5015
5	.0216	1.0509	.9498	.4704	2.1260	.5206
6	.0267	1.0890	.9516	.4757	2.1020	.5364
7	.0318	1.1197	.9532	.4802	2.0826	.5490
8	.0368	1.1654	.9550	.4868	2.0541	.5674
9	.0419	1.1929	.9560	.4916	2.0341	.5780
10	.0495	1.2272	.9562	.4980	2.0082	.5908
11	.0572	1.2612	.9568	.5041	1.9836	.6035
12	.0622	1.2928	.9583	.5095	1.9627	.6153
13	.0749	1.3424	.9594	.5189	1.9273	.6331
14	.0876	1.3820	.9619	.5257	1.9021	.6475
15	.1003	1.4166	.9637	.5321	1.8792	.6598
16	.1207	1.4569	.9644	.5405	1.8502	.6733
17	.1461	1.5009	.9659	.5495	1.8198	.6879
18	.1664	1.5262	.9668	.5549	1.8023	.6961
19	.2299	1.6019	.9693	.5713	1.7504	.7200
20	.2299	1.6017	.9687	.5716	1.7495	.7198
21	.2959	1.6579	.9688	.5854	1.7083	.7362
22	.3848	1.7345	.9718	.6031	1.6581	.7588
23	.4509	1.7872	.9752	.6149	1.6262	.7743
24	.5398	1.8562	.9774	.6324	1.5813	.7930
25	.6058	1.9027	.9788	.6445	1.5515	.8052
26	.6896	1.9669	.9796	.6626	1.5092	.8209
27	.7785	2.0332	.9809	.6815	1.4674	.8368
28	.8674	2.0979	.9822	.7005	1.4275	.8516
29	.9614	2.1605	.9834	.7195	1.3898	.8653
30	1.0605	2.2385	.9849	.7439	1.3443	.8818
31	1.1316	2.2936	.9864	.7613	1.3136	.8931
32	1.2535	2.3913	.9901	.7923	1.2622	.9127
33	1.3729	2.4790	.9934	.8211	1.2179	.9294
34	1.4745	2.5571	.9946	.8490	1.1779	.9428
35	1.5583	2.6157	.9966	.8696	1.1500	.9529
36	1.6421	2.6611	.9977	.8863	1.1283	.9603
37	1.7183	2.7060	.9975	.9041	1.1060	.9669
38	1.7818	2.7465	.9978	.9200	1.0869	.9728
39	1.8631	2.7880	.9992	.9355	1.0689	.9793
40	1.9571	2.8295	1.0007	.9512	1.0513	.9856
41	2.0714	2.8673	1.0020	.9657	1.0356	.9913
42	2.1781	2.8947	1.0020	.9772	1.0233	.9948
43	2.2746	2.9118	1.0006	.9859	1.0143	.9963
44	2.3736	2.9248	1.0008	.9912	1.0089	.9981
* 45	2.4575	2.9321	1.0021	.9930	1.0070	.9997
** 46	2.5921	2.9435	1.0000	1.0000	1.0000	1.0000
47	2.7394	2.9523	1.0002	1.0037	.9964	1.0012
48	2.9045	2.9569	1.0015	1.0044	.9957	1.0024
49	3.0188	2.9506	1.0013	1.0017	.9983	1.0015
50	3.2068	2.9292	1.0003	.9936	1.0065	.9984

NSWC TR 79-153

TABLE A-3 BOUNDARY LAYER PROFILE LISTING
RUN NO 801254

X = 1.981E+00 M	ME = 2.928E+00	DEL = 2.488E+00 CM
PO = 2.032E+05 N/M2	DE = 1.842E-01 KG/M3	DSTR = 8.212E-01 CM
TO = 3.178E+02 DEG.K	TE = 1.171E+02 DEG.K	TH = 1.643E-01 CM
PSW = 6.194E+03 N/M2	UE = 6.350E+02 M/S	THE = 2.944E-01 CM
TW = 2.979E+02 N/M2	RE = 1.440E+07 1/M	TTH = 9.607E-03 CM
TAUW = 4.566E+01 N/M2	CF = 1.230E-03	RETH = 6.004E+04
K = 1.016E-02 CM	MDOT = 1.465E-02 KG/M2*S	

N	Y (CM)	M	TT/TTE	D/DE	T/TE	U/UE
1	0.0000	0.0000	.9375	.3930	2.5446	0.0000
2	.0064	.8290	.9347	.4484	2.2303	.4229
3	.0140	.9123	.9402	.4571	2.1878	.4609
4	.0140	.9176	.9416	.4572	2.1873	.4635
5	.0216	.9966	.9463	.4667	2.1428	.4983
6	.0318	1.0558	.9516	.4735	2.1120	.5241
7	.0419	1.1133	.9535	.4822	2.0739	.5476
8	.0521	1.1531	.9552	.4883	2.0479	.5637
9	.0572	1.1838	.9564	.4932	2.0275	.5758
10	.0648	1.2116	.9578	.4976	2.0096	.5867
11	.0775	1.2492	.9580	.5046	1.9818	.6007
12	.0876	1.2741	.9577	.5096	1.9623	.6096
13	.0978	1.2939	.9565	.5141	1.9450	.6164
14	.1054	1.3135	.9561	.5183	1.9292	.6232
15	.1207	1.3391	.9551	.5241	1.9081	.6318
16	.1257	1.3507	.9546	.5268	1.8984	.6357
17	.1384	1.3746	.9535	.5324	1.8782	.6435
18	.1461	1.3853	.9513	.5359	1.8659	.6464
19	.1562	1.4015	.9512	.5395	1.8535	.6517
20	.1638	1.4099	.9510	.5414	1.8470	.6545
21	.2375	1.4996	.9592	.5569	1.7958	.6864
22	.3391	1.5868	.9600	.5771	1.7329	.7135
23	.4305	1.6540	.9723	.5863	1.7057	.7379
24	.5118	1.7195	.9707	.6040	1.6557	.7557
25	.5956	1.7817	.9749	.6178	1.6185	.7743
26	.6668	1.8362	.9775	.6311	1.5846	.7895
27	.8065	1.9353	.9840	.6549	1.5269	.8169
28	.9004	2.0006	.9862	.6727	1.4866	.8332
29	.9817	2.0650	.9879	.6910	1.4472	.8485
30	1.0503	2.1122	.9907	.7037	1.4210	.8601
31	1.2306	2.2516	.9952	.7456	1.3413	.8907
32	1.3119	2.3186	.9984	.7658	1.3058	.9050
33	1.3957	2.3781	1.0009	.7845	1.2748	.9171
34	1.4745	2.4364	1.0002	.8057	1.2412	.9272
35	1.5532	2.4944	1.0011	.8260	1.2107	.9375
36	1.6396	2.5497	1.0030	.8450	1.1835	.9475
37	1.7259	2.6013	1.0052	.8626	1.1593	.9567
38	1.7920	2.6415	1.0044	.8787	1.1380	.9625
39	1.8580	2.6798	1.0068	.8916	1.1216	.9694
40	1.9520	2.7314	1.0072	.9116	1.0970	.9772
41	2.0409	2.7805	1.0087	.9300	1.0752	.9848
42	2.0942	2.8214	1.0076	.9478	1.0551	.9899
43	2.1806	2.8528	1.0061	.9623	1.0392	.9934
44	2.2847	2.8876	1.0026	.9803	1.0201	.9962
45	2.3838	2.9092	1.0001	.9920	1.0081	.9977
* 46	2.4879	2.9276	1.0000	1.0000	1.0000	1.0000
47	2.7953	2.9556	.9994	1.0127	.9874	1.0032
48	2.9578	2.9656	1.0041	1.0123	.9878	1.0068
49	3.3465	2.9439	1.0061	1.0010	.9990	1.0051
50	3.6436	2.9462	1.0034	1.0046	.9954	1.0040

NSWC TR 79-153

TABLE A-3 BOUNDARY LAYER PROFILE LISTING
RUN NO 801255

X = 1.981E+00 M ME = 2.951E+00 DEL = 2.709E+00 CM
 PO = 1.031E+05 N/M2 DE = 9.688E-02 KG/M3 DSTR = 9.833E-01 CM
 TO = 3.128E+02 DFG.K TE = 1.141E+02 DEG.K TH = 1.842E-01 CM
 PSW = 3.142E+03 N/M2 UE = 6.318E+02 M/S THE = 3.273E-01 CM
 TW = 2.941E+02 N/M2 RE = 7.729E+06 1/M THH = 6.885E-04 CM
 TAUW = 2.237E+01 N/M2 CF = 1.158E-03 RETH = 3.612E+04
 K = 1.016E-02 CM MDOOT = 1.465E-02 KG/M2*^s

N	Y (CM)	M	TT/TTE	D/DE	T/TE	U/UE
1	0.0000	0.0000	.9402	.3880	2.5771	0.0000
2	.0064	.5782	.9259	.4204	2.3789	.3022
3	.0089	.6152	.9303	.4218	2.3706	.3210
4	.0140	.6890	.9268	.4310	2.3203	.3557
5	.0191	.7632	.9298	.4381	2.2828	.3908
6	.0241	.8343	.9330	.4455	2.2448	.4237
7	.0292	.8678	.9341	.4494	2.2254	.4387
8	.0343	.9179	.9366	.4551	2.1972	.4611
9	.0394	.9594	.9384	.4603	2.1723	.4793
10	.0445	.9933	.9408	.4643	2.1537	.4941
11	.0521	1.0272	.9435	.4683	2.1355	.5088
12	.0521	1.0287	.9435	.4685	2.1345	.5094
13	.0673	1.1000	.9473	.4783	2.0907	.5391
14	.0826	1.1341	.9503	.4827	2.0719	.5532
15	.1003	1.1748	.9525	.4887	2.0462	.5696
16	.1105	1.1992	.9536	.4926	2.0302	.5791
17	.1232	1.2208	.9558	.4955	2.0183	.5878
18	.1384	1.2435	.9576	.4988	2.0050	.5967
19	.1588	1.2739	.9598	.5035	1.9863	.6085
20	.1715	1.2956	.9617	.5067	1.9735	.6168
21	.2096	1.3459	.9653	.5148	1.9424	.6357
22	.2781	1.4118	.9680	.5271	1.8972	.6591
23	.3416	1.4651	.9734	.5357	1.8667	.6785
24	.4077	1.5169	.9755	.5461	1.8312	.6957
25	.4610	1.5581	.9785	.5539	1.8055	.7096
26	.5017	1.5872	.9808	.5594	1.7877	.7192
27	.5753	1.6381	.9846	.5694	1.7563	.7357
28	.6566	1.6918	.9867	.5814	1.7200	.7520
29	.7430	1.7533	.9900	.5951	1.6805	.7703
30	.8192	1.8053	.9933	.6067	1.6484	.7856
31	.9919	1.9302	.9987	.6375	1.5688	.8194
32	1.0706	1.9859	1.0009	.6520	1.5338	.8335
33	1.1443	2.0410	1.0038	.6662	1.5010	.8475
34	1.2002	2.0828	1.0051	.6779	1.4752	.8574
35	1.2687	2.1320	1.0077	.6912	1.4468	.8692
36	1.3500	2.1957	1.0097	.7097	1.4091	.8833
37	1.4288	2.2536	1.0097	.7283	1.3730	.8950
38	1.4973	2.3003	1.0104	.7431	1.3456	.9044
39	1.5735	2.3629	1.0115	.7634	1.3100	.9166
40	1.6548	2.4155	1.0100	.7827	1.2776	.9254
41	1.7717	2.4917	1.0092	.8104	1.2340	.9381
42	1.8834	2.5628	1.0092	.8363	1.1957	.9498
43	2.0206	2.6438	1.0081	.8677	1.1524	.9619
44	2.1120	2.7101	1.0078	.8937	1.1190	.9716
45	2.2187	2.7711	.9999	.9252	1.0808	.9764
46	2.3101	2.8169	.9998	.9439	1.0594	.9827
47	2.4041	2.8606	1.0004	.9615	1.0401	.9887
48	2.5413	2.9054	1.0010	.9797	1.0207	.9948
49	2.6302	2.9262	1.0006	.9889	1.0112	.9973
* 50	2.7089	2.9398	1.0011	.9943	1.0058	.9992

NSNC TR 79-153

TABLE A-3 BOUNDARY LAYER PROFILE LISTING
RUN NO 801255 CONT.

N	Y (CM)	M	TT/TTE	D/DE	T/TE	U/UE
** 51	2.7877	2.9505	1.0000	1.0000	1.0000	1.0000
52	2.8715	2.9589	.9990	1.0046	.9954	1.0005
53	2.9528	2.9666	.9985	1.0084	.9917	1.0012
54	3.0772	2.9729	.9989	1.0107	.9894	1.0022
55	3.1763	2.9742	.9980	1.0123	.9878	1.0019
56	3.3160	2.9666	1.0011	1.0059	.9942	1.0025
57	3.4455	2.9544	1.0010	1.0006	.9994	1.0010
58	3.6563	2.9496	1.0017	.9979	1.0021	1.0007

NSWC TR 79-153

TABLE A-3 BOUNDARY LAYER PROFILE LISTING
RUN NO 801256

X = 1.981E+00 M	ME = 2.939E+00	DFL = 3.352E+00 CM
PO = 5.212E+04 N/M2	DE = 4.960E-02 KG/M3	DSTR = 1.200E+00 CM
TO = 3.156E+02 DEG.K	TE = 1.157E+02 DEG.K	TH = 2.340E-01 CM
PSW = 1.625E+03 N/M2	UE = 6.338E+02 M/S	THE = 4.101E-01 CM
TW = 2.939E+02 N/M2	RE = 3.916E+06 1/M	THH = 2.324E-02 CM
TAUW = 1.064E+01 N/M2	CF = 1.069E-03	RETH = 2.326E+04
K = 1.016E-02 CM	MDOT = 1.465E-02 KG/M2*S	

N	Y (CM)	M	TT/TTE	D/DE	T/TTE	U/UE
1	0.0000	0.0000	.9311	.3937	2.5400	0.0000
2	.0064	.4296	.9172	.4144	2.4130	.2270
3	.0114	.4450	.9193	.4146	2.4122	.2351
4	.0140	.4823	.9206	.4167	2.3996	.2542
5	.0216	.5280	.9226	.4195	2.3839	.2773
6	.0241	.5747	.9216	.4240	2.3584	.3002
7	.0292	.6193	.9197	.4291	2.3302	.3217
8	.0292	.6250	.9186	.4302	2.3243	.3242
9	.0419	.7494	.9214	.4425	2.2597	.3833
10	.0546	.8444	.9232	.4537	2.2040	.4265
11	.0724	.9317	.9266	.4643	2.1537	.4652
12	.0851	.9863	.9291	.4713	2.1217	.4888
13	.1054	1.0364	.9326	.4775	2.0942	.5102
14	.1207	1.0679	.9355	.4812	2.0781	.5237
15	.1384	1.1036	.9392	.4854	2.0602	.5389
16	.1537	1.1230	.9420	.4873	2.0521	.5473
17	.1689	1.1471	.9432	.4909	2.0370	.5570
18	.2426	1.2372	.9471	.5055	1.9781	.5920
19	.3188	1.3008	.9470	.5181	1.9301	.6148
20	.3975	1.3602	.9489	.5292	1.8895	.6361
21	.4966	1.4396	.9532	.5440	1.8383	.6640
22	.5982	1.5033	.9550	.5573	1.7943	.6851
23	.7252	1.5772	.9595	.5722	1.7478	.7094
24	.8598	1.6556	.9643	.5886	1.6990	.7342
25	1.0249	1.7639	.9671	.6149	1.6262	.7653
26	1.1367	1.8312	.9704	.6311	1.5844	.7842
27	1.2383	1.8954	.9738	.6469	1.5458	.8017
28	1.3195	1.9525	.9768	.6614	1.5119	.8168
29	1.4135	2.0136	.9787	.6783	1.4744	.8318
30	1.4999	2.0693	.9824	.6927	1.4436	.8458
31	1.5786	2.1226	.9866	.7063	1.4157	.8592
32	1.6624	2.1783	.9877	.7233	1.3825	.8714
33	1.7691	2.2473	.9907	.7438	1.3444	.8865
34	1.8555	2.3108	.9943	.7624	1.3116	.9004
35	1.9622	2.3747	.9962	.7830	1.2772	.9130
36	2.0638	2.4477	.9993	.8064	1.2401	.9274
37	2.1704	2.5128	1.0007	.8289	1.2064	.9390
38	2.2441	2.5571	1.0011	.8450	1.1834	.9464
39	2.3330	2.6123	1.0027	.8646	1.1566	.9558
40	2.4041	2.6534	1.0025	.8806	1.1357	.9620
41	2.6124	2.7678	1.0028	.9256	1.0804	.9787
42	2.8156	2.8510	1.0040	.9587	1.0431	.9906
43	3.1026	2.9185	1.0019	.9892	1.0109	.9983
* 44	3.3515	2.9393	1.0000	1.0000	1.0000	1.0000
45	3.6055	2.9380	.9988	1.0007	.9993	.9992
46	3.7478	2.9349	.9994	.9986	1.0014	.9992
47	3.9662	2.9302	.9989	.9972	1.0028	.9983
48	4.3091	2.9306	.9992	.9970	1.0030	.9985
49	4.7206	2.9212	.9993	.9929	1.0072	.9974
50	5.1295	2.9068	.9992	.9868	1.0133	.9955

NSWC TR 79-153

TABLE A-3 BOUNDARY LAYER PROFILE LISTING
RUN NO 801263

X = 1.981E+00 M	ME = 2.945E+00	DEL = 2.567E+00 CM
PO = 4.120E+05 N/M2	DE = 3.674E-01 KG/M3	DSTR = 7.818E-01 CM
TO = 3.196E+02 DEG.K	TE = 1.169E+02 DEG.K	TH = 1.619E-01 CM
PSW = 1.235E+04 N/M2	UE = 6.382E+02 M/S	THE = 2.919E-01 CM
TW = 2.951E+02 N/M2	RE = 2.891E+07 1/M	THH = 1.926E-02 CM
TAUW = 9.450E+01 N/M2	CF = 1.264E-03	RETH = 1.188E+05
K = 1.016E-02 CM	MDOT = 4.883E-02 KG/M2*5	

N	Y (CM)	M	TT/TTE	D/DE	T/TE	U/UE
1	0.0000	0.0000	.9233	.3961	2.5244	0.0000
2	.0064	.8608	.9422	.4457	2.2435	.4379
3	.0114	.8672	.9430	.4462	2.2411	.4409
4	.0191	.9072	.9449	.4508	2.2183	.4589
5	.0267	.9653	.9457	.4588	2.1795	.4840
6	.0343	1.0468	.9497	.4695	2.1298	.5188
7	.0495	1.1217	.9518	.4810	2.0791	.5493
8	.0597	1.1853	.9535	.4914	2.0351	.5743
9	.0699	1.2374	.9560	.4998	2.0009	.5945
10	.0826	1.2812	.9581	.5071	1.9721	.6110
11	.0927	1.3134	.9581	.5135	1.9475	.6225
12	.1029	1.3466	.9593	.5196	1.9247	.6345
13	.1130	1.3651	.9606	.5227	1.9132	.6412
14	.1232	1.3955	.9623	.5281	1.8934	.6521
15	.1359	1.4173	.9631	.5324	1.8784	.6597
16	.1511	1.4447	.9640	.5378	1.8595	.6691
17	.1638	1.4582	.9639	.5408	1.8491	.6734
18	.1740	1.4811	.9654	.5451	1.8344	.6813
19	.1842	1.4902	.9657	.5470	1.8282	.6843
20	.1969	1.5048	.9662	.5500	1.8182	.6891
21	.2070	1.5123	.9659	.5519	1.8119	.6914
22	.2223	1.5321	.9660	.5564	1.7973	.6976
23	.2223	1.5356	.9649	.5578	1.7927	.6983
24	.2426	1.5591	.9670	.5622	1.7788	.7062
25	.2578	1.5723	.9680	.5647	1.7709	.7106
26	.2731	1.5828	.9672	.5676	1.7617	.7135
27	.2985	1.6111	.9676	.5742	1.7414	.7220
28	.3162	1.6226	.9686	.5765	1.7347	.7258
29	.3315	1.6342	.9702	.5784	1.7290	.7298
30	.3416	1.6462	.9706	.5811	1.7209	.7334
31	.3645	1.6637	.9700	.5858	1.7070	.7382
32	.3747	1.6674	.9696	.5870	1.7036	.7391
33	.4432	1.7238	.9709	.6006	1.6650	.7554
34	.5118	1.7663	.9729	.6105	1.6380	.7677
35	.5779	1.8229	.9754	.6242	1.6021	.7836
36	.6642	1.8860	.9775	.6404	1.5616	.8004
37	.7379	1.9382	.9786	.6546	1.5277	.8136
38	.8369	2.0103	.9796	.6751	1.4812	.8309
39	.9106	2.0656	.9813	.6908	1.4477	.8440
40	1.0427	2.1609	.9848	.7183	1.3922	.8659
41	1.1316	2.2289	.9867	.7390	1.3532	.8806
42	1.2129	2.2950	.9886	.7597	1.3163	.8942
43	1.2891	2.3525	.9890	.7792	1.2834	.9051
44	1.3780	2.4231	.9897	.8035	1.2445	.9180
45	1.4821	2.5055	.9918	.8318	1.2022	.9330
46	1.6116	2.5913	.9945	.8617	1.1605	.9480
47	1.7310	2.6671	.9957	.8899	1.1237	.9602
48	1.8529	2.7452	.9963	.9204	1.0864	.9718
49	2.0104	2.8205	.9968	.9508	1.0518	.9824
50	2.1019	2.8539	.9987	.9628	1.0386	.9878

NSWC TR 79-153

TABLE A-3 BOUNDARY LAYER PROFILE LISTING
 RUN NO 801263 CONT.

N	Y(CM)	M	TT/TTE	D/DE	T/TE	U/UE
51	2.1831	2.8789	.9992	.9728	1.0280	.9913
52	2.2847	2.8991	.9985	.9821	1.0182	.9935
53	2.3838	2.9153	.9964	.9911	1.0090	.9945
54	2.4829	2.9272	.9972	.9953	1.0047	.9965
* 55	2.5667	2.9350	.9986	.9973	1.0027	.9981
** 56	2.6734	2.9445	1.0000	1.0000	1.0000	1.0000
57	2.8105	2.9510	.9983	1.0045	.9955	1.0000
58	2.9096	2.9555	.9972	1.0075	.9925	1.0000
59	3.0798	2.9244	.9966	.9948	1.0052	.9958
60	3.2195	2.9323	.9973	.9974	1.0026	.9972
61	3.3414	2.9229	.9966	.9942	1.0059	.9956
62	3.4658	2.9223	.9941	.9963	1.0037	.9943
63	3.8443	2.9334	.9944	1.0008	.9992	.9958
64	4.1313	2.9379	.9951	1.0021	.9979	.9967
65	4.4412	2.9270	.9942	.9982	1.0018	.9949
66	4.8959	2.9164	.9940	.9939	1.0061	.9935
67	5.1626	2.9151	.9928	.9946	1.0055	.9927
68	5.3658	2.9215	.9923	.9978	1.0023	.9933
69	5.4978	2.9284	.9913	1.0018	.9982	.9936
70	5.6071	2.9333	.9902	1.0050	.9950	.9937
71	5.7493	2.9376	.9891	1.0080	.9920	.9937
72	5.8738	2.9374	.9879	1.0091	.9909	.9931
73	6.0135	2.9352	.9873	1.0088	.9912	.9925
74	6.1684	2.9292	.9860	1.0075	.9925	.9911
75	6.3919	2.9195	.9846	1.0047	.9953	.9892
76	6.6739	2.9264	.9848	1.0076	.9925	.9901
77	7.5095	2.9440	.9799	1.0203	.9801	.9898

NSWC TR 79-153

TABLE A-3 BOUNDARY LAYER PROFILE LISTING
RUN NO 801257

X = 1.981E+00 M	ME = 2.945E+00	DEL = 2.849E+00 CM
PO = 2.034E+05 N/M2	DE = 1.906E-01 KG/M3	DSTR = 9.355E-01 CM
TO = 3.153E+02 DEG.K	TE = 1.153E+02 DEG.K	TH = 1.785E-01 CM
PSW = 6.231E+03 N/M2	UE = 6.339E+02 M/S	THE = 3.178E-01 CM
TW = 2.968E+02 N/M2	RE = 1.510E+07 1/M	THH = 3.280E-03 CM
TAUW = 3.920E+01 N/M2	CF = 1.024E-03	RETH = 6.840E+04
K = 1.016E-02 CM	MDOT = 4.883E-02 KG/M2*S	

N	Y (CM)	M	TT/TTE	D/DE	T/TE	U/UE
1	0.0000	0.0000	.9416	.3884	2.5749	0.0000
2	.0064	.7158	.9347	.4313	2.3185	.3701
3	.0089	.7748	.9381	.4366	2.2905	.3982
4	.0165	.8323	.9363	.4447	2.2488	.4238
5	.0267	.9280	.9429	.4544	2.1998	.4673
6	.0368	.9926	.9482	.4616	2.1662	.4960
7	.0495	1.0550	.9524	.4694	2.1303	.5228
8	.0597	1.0892	.9535	.4745	2.1075	.5369
9	.0699	1.1239	.9539	.4802	2.0825	.5507
10	.0826	1.1555	.9566	.4843	2.0647	.5638
11	.0927	1.1819	.9615	.4866	2.0552	.5753
12	.1054	1.2165	.9632	.4920	2.0325	.5889
13	.1181	1.2384	.9643	.4955	2.0181	.5974
14	.1283	1.2542	.9640	.4986	2.0054	.6031
15	.1384	1.2760	.9627	.5035	1.9860	.6106
16	.1486	1.2889	.9580	.5085	1.9664	.6137
17	.1562	1.3055	.9576	.5120	1.9531	.6195
18	.2172	1.3865	.9558	.5297	1.8879	.6469
19	.3061	1.4667	.9584	.5457	1.8326	.6742
20	.3035	1.4721	.9585	.5468	1.8287	.6759
21	.3848	1.5372	.9682	.5562	1.7981	.6999
22	.4509	1.5944	.9710	.5680	1.7605	.7183
23	.5398	1.6460	.9726	.5797	1.7250	.7341
24	.6464	1.7268	.9794	.5960	1.6779	.7595
25	.7607	1.8051	.9865	.6122	1.6334	.7833
26	.9004	1.9087	.9922	.6371	1.5697	.8120
27	1.1062	2.0577	1.0009	.6747	1.4821	.8506
28	1.2764	2.1783	1.0040	.7099	1.4087	.8779
29	1.3830	2.2608	1.0055	.7354	1.3598	.8952
30	1.5202	2.3680	1.0083	.7694	1.2997	.9167
31	1.6167	2.4334	1.0097	.7910	1.2642	.9290
32	1.7539	2.5255	1.0109	.8232	1.2148	.9451
33	1.9164	2.6282	1.0062	.8654	1.1555	.9593
34	2.0231	2.6916	1.0060	.8902	1.1234	.9687
35	2.0917	2.7415	1.0045	.9112	1.0975	.9752
36	2.2187	2.8100	1.0032	.9402	1.0637	.9840
37	2.3482	2.8616	1.0025	.9621	1.0393	.9906
38	2.4778	2.8984	1.0031	.9770	1.0235	.9956
39	2.6530	2.9284	1.0025	.9904	1.0097	.9991
* 40	2.8486	2.9451	1.0000	1.0000	1.0000	1.0000
41	3.1255	2.9568	1.0014	1.0036	.9964	1.0022
42	3.2830	2.9502	1.0024	.9998	1.0002	1.0018
43	3.4963	2.9371	1.0028	.9938	1.0063	1.0004
44	3.7478	2.9416	1.0009	.9975	1.0025	1.0000
45	3.9205	2.9412	1.0013	.9970	1.0030	1.0002
46	4.2101	2.9373	.9990	.9976	1.0024	.9985
47	4.5225	2.9308	1.0002	.9937	1.0064	.9983
48	4.8324	2.9193	1.0011	.9879	1.0123	.9973
49	5.2057	2.9129	1.0022	.9840	1.0162	.9971
50	5.5791	2.9299	1.0022	.9914	1.0087	.9992

NSWC TR 79-153

TABLE A-3 BOUNDARY LAYER PROFILE LISTING
RUN NO 801258

X = 1.981E+00 M	ME = 2.933E+00	DEL = 3.034E+00 CM
PO = 1.031E+05 N/M2	DE = 9.637E-02 KG/M3	DSTR = 1.161E+00 CM
TO = 3.154E+02 DEG.K	TE = 1.159E+02 DEG.K	TH = 2.242E-01 CM
PSW = 3.178E+03 N/M2	UE = 6.331E+02 M/S	THE = 3.915E-01 CM
TW = 2.930E+02 N/M2	RE = 7.584E+06 1/M	THH = 1.984E-02 CM
TAUW = 1.563E+01 N/M2	CF = 8.099E-04	HETH = 4.315E+04
K = 1.016E-02 CM	MDOT = 4.883E-02 KG/M2*S	

N	Y (CM)	M	TT/TTE	D/DE	T/TE	U/UE
1	0.0000	0.0000	.9288	.3957	2.5270	0.0000
2	.0064	.4885	.9157	.4206	2.3778	.2568
3	.0114	.5245	.9147	.4239	2.3589	.2746
4	.0114	.5570	.9163	.4261	2.3471	.2909
5	.0191	.6279	.9179	.4320	2.3147	.3257
6	.0267	.7071	.9204	.4393	2.2764	.3637
7	.0368	.7702	.9232	.4454	2.2454	.3935
8	.0445	.8271	.9258	.4513	2.2157	.4197
9	.0546	.8772	.9283	.4569	2.1888	.4424
10	.0622	.9132	.9302	.4611	2.1688	.4585
11	.0724	.9437	.9327	.4643	2.1538	.4722
12	.0826	.9706	.9350	.4672	2.1405	.4842
13	.0902	.9912	.9361	.4698	2.1285	.4930
14	.0978	1.0052	.9376	.4713	2.1219	.4992
15	.1080	1.0235	.9396	.4731	2.1135	.5073
16	.1207	1.0467	.9443	.4745	2.1073	.5180
17	.1334	1.0724	.9476	.4771	2.0959	.5293
18	.1486	1.0938	.9489	.4801	2.0830	.5382
19	.1664	1.1188	.9514	.4831	2.0701	.5488
20	.1816	1.1388	.9524	.4860	2.0575	.5569
21	.1994	1.1634	.9527	.4902	2.0398	.5665
22	.2146	1.1816	.9522	.4938	2.0251	.5733
23	.2324	1.1977	.9511	.4973	2.0107	.5790
24	.2680	1.2425	.9505	.5061	1.9758	.5955
25	.3315	1.2865	.9514	.5142	1.9447	.6117
26	.3950	1.3403	.9534	.5241	1.9082	.6312
27	.4890	1.4015	.9546	.5363	1.8645	.6525
28	.5779	1.4715	.9588	.5494	1.8203	.6769
29	.6566	1.5132	.9610	.5577	1.7932	.6909
30	.7455	1.5731	.9643	.5698	1.7549	.7105
31	.8471	1.6318	.9685	.5816	1.7193	.7295
32	.9385	1.6933	.9711	.5956	1.6790	.7481
33	1.0351	1.7590	.9752	.6102	1.6389	.7678
34	1.1062	1.8059	.9765	.6219	1.6080	.7807
35	1.1697	1.8571	.9804	.6335	1.5785	.7955
36	1.3145	1.9542	.9851	.6581	1.5195	.8213
37	1.4415	2.0465	.9885	.6833	1.4635	.8441
38	1.5024	2.0861	.9898	.6945	1.4398	.8534
39	1.5812	2.1498	.9907	.7140	1.4006	.8674
40	1.6777	2.2203	.9927	.7354	1.3599	.8828
41	1.7615	2.2767	.9947	.7526	1.3288	.8947
42	1.8402	2.3412	.9970	.7728	1.2940	.9080
43	1.9215	2.3984	.9978	.7922	1.2623	.9187
44	2.0282	2.4711	.9990	.8173	1.2236	.9319
45	2.1069	2.5327	1.0001	.8391	1.1918	.9427
46	2.2085	2.5957	1.0007	.8623	1.1597	.9530
47	2.3051	2.6566	1.0020	.8846	1.1304	.9630
48	2.3965	2.7082	1.0016	.9053	1.1046	.9704
49	2.4981	2.7685	1.0012	.9299	1.0754	.9788
50	2.6099	2.8233	1.0012	.9524	1.0500	.9863

NSWC TR 79-153

TABLE A-3 BOUNDARY LAYER PROFILE LISTING
 RUN NO 801258 CONT.

N	Y (CM)	M	TT/TTE	D/DE	T/TE	U/UE
51	2.7826	2.8837	1.0006	.9783	1.0222	.9940
52	2.9223	2.9150	1.0006	.9916	1.0085	.9980
* 53	3.0340	2.9331	1.0000	1.0000	1.0000	1.0000
54	3.2906	2.9536	.9994	1.0095	.9906	1.0023
55	3.4963	2.9553	.9999	1.0097	.9904	1.0027
56	3.7097	2.9470	.9996	1.0064	.9937	1.0016
57	3.8646	2.9429	1.0004	1.0039	.9961	1.0014
58	4.0424	2.9424	1.0002	1.0038	.9962	1.0013
59	4.2050	2.9407	.9991	1.0042	.9958	1.0005
60	4.3421	2.9395	.9998	1.0030	.9970	1.0007
61	4.4615	2.9380	1.0006	1.0016	.9984	1.0009
62	4.6266	2.9357	.9986	1.0026	.9975	.9996
63	4.7587	2.9325	.9989	1.0009	.9991	.9994
64	4.9187	2.9267	.9999	.9974	1.0026	.9991
65	5.1143	2.8989	.9987	.9866	1.0136	.9950
66	5.3607	2.9123	.9993	.9917	1.0083	.9971
67	5.5842	2.9170	.9997	.9934	1.0066	.9978
68	5.8941	2.9281	1.0001	.9977	1.0023	.9994
69	6.1836	2.9356	1.0003	1.0008	.9992	1.0005
70	6.4707	2.9321	1.0006	.9990	1.0010	1.0002
71	6.7450	2.9181	1.0003	.9932	1.0068	.9983

NSWC TR 79-153

TABLE A-3 BOUNDARY LAYER PROFILE LISTING
RUN NO 801259

X = 1.981E+00 M ME = 2.898E+00
 PO = 5.240E+04 N/M2 DE = 4.955E-02 KG/M3
 TO = 3.165E+02 DEG.K TE = 1.181E+02 DEG.K
 PSW = 1.667E+03 N/M2 UE = 6.313E+02 M/S
 TW = 2.939E+02 N/M2 RE = 3.817E+06 I/M
 TAUW = 4.617E+00 N/M2 CF = 4.679E-04
 K = 1.016E-02 CM MDOT = 4.883E-02 KG/M2*
 DEL = 3.705E+00 CM
 DSTR = 1.586E+00 CM
 TH = 2.940E-01 CM
 THE = 4.996E-01 CM
 THH = 2.479E-02 CM
 RETH = 2.848E+04

N	Y(CM)	M	TT/TTE	D/DE	T/TE	U/UE
1	0.0000	0.0000	.9284	.4021	2.4872	0.0000
2	.0064	.3397	.9145	.4176	2.3946	.1814
3	.0089	.3573	.9153	.4182	2.3911	.1907
4	.0318	.4817	.9139	.4274	2.3398	.2543
5	.0521	.6070	.9180	.4366	2.2905	.3171
6	.0724	.6767	.9211	.4423	2.2607	.3512
7	.0876	.7282	.9237	.4469	2.2374	.3759
8	.1054	.7663	.9257	.4506	2.2195	.3940
9	.1283	.8031	.9267	.4548	2.1989	.4110
10	.1461	.8480	.9268	.4607	2.1706	.4312
11	.1715	.8738	.9276	.4639	2.1559	.4428
12	.1892	.8900	.9285	.4657	2.1472	.4501
13	.2070	.9193	.9283	.4701	2.1273	.4627
14	.2299	.9395	.9284	.4730	2.1140	.4714
15	.2502	.9605	.9293	.4758	2.1019	.4806
16	.2731	.9754	.9293	.4781	2.0917	.4869
17	.2934	.9943	.9292	.4811	2.0785	.4947
18	.3239	1.0113	.9306	.4831	2.0699	.5021
19	.3467	1.0351	.9308	.4869	2.0537	.5120
20	.3924	1.0662	.9315	.4918	2.0332	.5247
21	.4153	1.0796	.9298	.4950	2.0200	.5296
22	.4382	1.0925	.9297	.4973	2.0108	.5347
23	.4559	1.1030	.9299	.4991	2.0037	.5389
24	.5220	1.1442	.9348	.5039	1.9847	.5563
25	.6236	1.2023	.9388	.5125	1.9511	.5796
26	.6922	1.2401	.9422	.5180	1.9304	.5947
27	.7684	1.2690	.9484	.5203	1.9219	.6072
28	.8420	1.3124	.9533	.5264	1.8996	.6243
29	.9258	1.3629	.9585	.5341	1.8723	.6436
30	1.0782	1.4445	.9636	.5490	1.8213	.6728
31	1.0782	1.4478	.9631	.5500	1.8180	.6737
32	1.3094	1.6010	.9703	.5819	1.7186	.7244
33	1.4821	1.6801	.9765	.5980	1.6722	.7498
34	1.5710	1.7310	.9775	.6107	1.6375	.7645
35	1.6828	1.7999	.9806	.6273	1.5941	.7843
36	1.7818	1.8610	.9844	.6418	1.5581	.8017
37	1.8453	1.9226	.9844	.6595	1.5163	.8171
38	2.0485	2.0527	.9905	.6944	1.4401	.8502
39	2.1476	2.1257	.9931	.7155	1.3976	.8673
40	2.2339	2.1803	.9950	.7318	1.3665	.8796
41	2.3381	2.2502	.9971	.7534	1.3272	.8947
42	2.4397	2.3164	.9986	.7749	1.2905	.9082
43	2.5616	2.3997	1.0003	.8029	1.2454	.9243
44	2.6708	2.4696	1.0024	.8266	1.2098	.9375
45	2.8181	2.5616	1.0044	.8594	1.1636	.9537
46	2.9274	2.6293	1.0051	.8849	1.1301	.9647
47	3.0442	2.6930	1.0048	.9103	1.0986	.9742
48	3.1610	2.7564	1.0054	.9354	1.0691	.9836
49	3.2703	2.8010	1.0044	.9547	1.0474	.9894
50	3.3642	2.8321	1.0037	.9684	1.0326	.9932

NSWC TR 79-153

TABLE A-3 BOUNDARY LAYER PROFILE LISTING
RUN NO 801259 CONT.

N	Y (CM)	M	TT/TTE	D/DE	T/TE	U/UE
51	3.4684	2.8635	1.0018	.9836	1.0167	.9965
52	3.5700	2.8823	1.0009	.9926	1.0075	.9985
* 53	3.7046	2.8975	1.0000	1.0000	1.0000	1.0000
54	3.8621	2.9088	.9987	1.0062	.9939	1.0008
55	3.4354	2.8579	.9969	.9860	1.0142	.9933
56	3.9332	2.9093	.9961	1.0091	.9910	.9996
57	4.4590	2.9086	.9963	1.0086	.9915	.9996
58	4.9492	2.9074	.9952	1.0092	.9909	.9988
59	5.4724	2.8997	.9950	1.0060	.9940	.9978
60	5.9754	2.8907	.9950	1.0021	.9979	.9966
61	6.2827	2.8949	.9941	1.0048	.9952	.9967

NSWC TR 79-153

TABLE A-3 BOUNDARY LAYER PROFILE LISTING
RUN NO 801264

X = 1.981E+00 M	ME = 2.933E+00	DEL = 2.729E+00 CM
PO = 4.122E+05 N/M2	DE = 3.692E-01 KG/M3	DSTR = 9.486E-01 CM
TO = 3.208E+02 DFG.K	TE = 1.179E+02 DEG.K	TH = 1.911E-01 CM
PSW = 1.244E+04 N/M2	UE = 6.384E+02 M/S	THE = 3.380E-01 CM
TW = 2.887E+02 N/M2	RE = 2.881E+07 1/M	THH = 2.203E-02 CM
FAUW = 7.443E+01 N/M2	CF = 9.900E-04	RETH = 1.397E+05
K = 1.016E-02 CM	MDOT = 1.465E-01 KG/M2* ^s	

N	Y (CM)	M	TT/TTE	D/DE	T/TE	U/UE
1	0.0000	0.0000	.9001	.4085	2.4481	0.0000
2	.0064	.7355	.9152	.4452	2.2463	.3759
3	.0267	.7678	.9184	.4475	2.2345	.3914
4	.0546	.9483	.9249	.4690	2.1322	.4722
5	.1105	1.1502	.9331	.4982	2.0071	.5556
6	.1435	1.2269	.9370	.5105	1.9589	.5856
7	.1867	1.3024	.9408	.5234	1.9107	.6139
8	.2350	1.3628	.9435	.5344	1.8713	.6357
9	.3035	1.4294	.9471	.5468	1.8287	.6591
10	.3975	1.5035	.9509	.5615	1.7811	.6842
11	.4255	1.5279	.9534	.5657	1.7678	.6928
12	.4432	1.5435	.9551	.5684	1.7595	.6982
13	.4686	1.5602	.9563	.5716	1.7493	.7037
14	.4864	1.5786	.9581	.5750	1.7391	.7099
15	.4991	1.5833	.9599	.5750	1.7390	.7120
16	.5626	1.6230	.9625	.5832	1.7146	.7247
17	.6312	1.6787	.9650	.5957	1.6787	.7417
18	.6998	1.7196	.9670	.6051	1.6528	.7539
19	.7633	1.7654	.9691	.6158	1.6238	.7671
20	.7633	1.7664	.9709	.6150	1.6261	.7681
21	.8242	1.8110	.9736	.6253	1.5992	.7809
22	.8979	1.8602	.9758	.6375	1.5686	.7945
23	.9665	1.9089	.9774	.6503	1.5378	.8072
24	1.0376	1.9638	.9798	.6647	1.5045	.8214
25	1.1062	2.0102	.9819	.6771	1.4770	.8331
26	1.1722	2.0629	.9835	.6920	1.4450	.8456
27	1.2332	2.1082	.9855	.7047	1.4190	.8564
28	1.2992	2.1538	.9868	.7182	1.3924	.8666
29	1.3678	2.2057	.9884	.7339	1.3625	.8780
30	1.4465	2.2742	.9898	.7557	1.3233	.8921
31	1.5100	2.3247	.9912	.7718	1.2956	.9023
32	1.5812	2.3736	.9926	.7878	1.2694	.9119
33	1.6574	2.4348	.9942	.8082	1.2373	.9235
34	1.7259	2.4798	.9948	.8241	1.2134	.9315
35	1.7767	2.5341	.9956	.8436	1.1854	.9409
36	1.8504	2.5759	.9966	.8585	1.1649	.9480
37	1.9266	2.6384	.9976	.8817	1.1342	.9582
38	2.0130	2.6862	.9981	.8999	1.1112	.9656
39	2.1019	2.7323	.9992	.9173	1.0901	.9728
40	2.1882	2.7797	.9997	.9361	1.0683	.9797
41	2.2847	2.8219	1.0006	.9526	1.0497	.9859
42	2.3660	2.8477	1.0006	.9634	1.0380	.9894
43	2.4575	2.8763	1.0012	.9748	1.0258	.9934
44	2.6251	2.9074	1.0013	.9879	1.0122	.9974
* 45	2.7292	2.9201	1.0009	.9937	1.0063	.9989
** 46	2.8410	2.9325	1.0000	1.0000	1.0000	1.0000
47	3.0163	2.9462	.9997	1.0062	.9938	1.0016
48	3.1534	2.9496	.9992	1.0082	.9918	1.0017
49	3.3769	2.9358	.9983	1.0031	.9969	.9995
50	3.5039	2.9254	.9981	.9988	1.0012	.9981

NSWC TR 79-153

TABLE A-3 BOUNDARY LAYER PROFILE LISTING
RUN NO 801264 CONT.

N	Y (CM)	M	TT/TTE	D/DE	T/TE	U/UE
51	3.5928	2.9211	.9968	.9983	1.0017	.9970
52	3.6386	2.9199	.9962	.9984	1.0016	.9965
53	3.6767	2.9194	.9950	.9994	1.0006	.9958
54	3.7198	2.9192	.9938	1.0005	.9995	.9952
55	3.8367	2.9215	.9927	1.0026	.9974	.9949
56	3.9281	2.9228	.9910	1.0049	.9952	.9943
57	4.0373	2.9253	.9904	1.0065	.9935	.9943
58	4.1847	2.9282	.9922	1.0060	.9941	.9956
59	4.3879	2.9305	.9917	1.0075	.9925	.9956
60	4.6088	2.9241	.9887	1.0078	.9923	.9933
61	4.8755	2.9126	.9866	1.0048	.9952	.9908
62	5.2184	2.9077	.9877	1.0016	.9984	.9907
63	5.5334	2.9146	.9884	1.0039	.9961	.9919
64	5.7722	2.9255	.9887	1.0084	.9917	.9934
65	6.1811	2.9273	.9887	1.0091	.9909	.9937

NSWC TR 79-153

TABLE A-3 BOUNDARY LAYER PROFILE LISTING
RUN NO 801265

X = 1.981E+00 M ME = 2.913E+00 DEL = 3.336E+00 CM
 PO = 2.033E+05 N/M2 DE = 1.894E-01 KG/M3 DSTP = 1.263E+00 CM
 TO = 3.226E+02 DFG.K TE = 1.196E+02 DEG.K TH = 2.371E-01 CM
 PSW = 6.352E+03 N/M2 UE = 6.387E+02 M/S THE = 4.132E-01 CM
 TW = 3.016E+02 N/M2 RE = 1.459E+07 1/M THH = 1.090E-02 CM
 TAUW = 1.966E+01 N/M2 CF = 5.094E-04 RETH = 8.778E+04
 K = 1.016E-02 CM MDOT = 1.465E-01 KG/M2*S

N	Y (CM)	M	TT/TTE	D/DE	T/TE	U/UE
1	0.0000	0.0000	.9349	.3965	2.5221	0.0000
2	.0064	.5349	.9458	.4144	2.4133	.2852
3	.0114	.5745	.9475	.4170	2.3978	.3054
4	.0191	.6250	.9497	.4208	2.3763	.3307
5	.0267	.6634	.9532	.4231	2.3634	.3500
6	.0292	.7011	.9539	.4268	2.3429	.3684
7	.0419	.7618	.9571	.4323	2.3134	.3977
8	.0546	.8069	.9610	.4360	2.2937	.4195
9	.0648	.8521	.9626	.4410	2.2675	.4404
10	.0800	.8861	.9639	.4450	2.2473	.4559
11	.0902	.9125	.9660	.4476	2.2340	.4681
12	.1003	.9377	.9676	.4505	2.2197	.4795
13	.1130	.9673	.9693	.4540	2.2025	.4927
14	.1232	.9859	.9694	.4567	2.1894	.5007
15	.1359	1.0137	.9704	.4605	2.1716	.5127
16	.1486	1.0313	.9700	.4635	2.1576	.5200
17	.1613	1.0482	.9706	.4658	2.1466	.5271
18	.1715	1.0654	.9609	.4734	2.1126	.5315
19	.1740	1.0642	.9701	.4687	2.1336	.5335
20	.1918	1.0904	.9711	.4725	2.1164	.5445
21	.2070	1.0982	.9714	.4737	2.1112	.5477
22	.2197	1.1246	.9718	.4779	2.0924	.5584
23	.2375	1.1458	.9652	.4849	2.0622	.5648
24	.2451	1.1449	.9720	.4813	2.0776	.5664
25	.2451	1.1421	.9696	.4821	2.0745	.5646
26	.2629	1.1613	.9692	.4856	2.0592	.5720
27	.2807	1.1746	.9691	.4880	2.0490	.5771
28	.3137	1.2092	.9693	.4943	2.0232	.5904
29	.3391	1.2347	.9714	.4980	2.0082	.6006
30	.3391	1.2305	.9666	.4996	2.0016	.5975
31	.3569	1.2428	.9648	.5029	1.9885	.6015
32	.3721	1.2503	.9651	.5047	1.9834	.6044
33	.3899	1.2484	.9702	.5017	1.9954	.6053
34	.4051	1.2606	.9771	.5000	2.0002	.6119
35	.4178	1.2884	.9753	.5063	1.9751	.6215
36	.4280	1.2888	.9788	.5045	1.9820	.6228
37	.4483	1.3112	.9768	.5100	1.9607	.6302
38	.4585	1.3204	.9760	.5123	1.9521	.6332
39	.4712	1.3254	.9767	.5129	1.9498	.6352
40	.4864	1.3340	.9765	.5147	1.9428	.6382
41	.4890	1.3389	.9790	.5144	1.9440	.6408
42	.5702	1.3924	.9817	.5240	1.9083	.6602
43	.6566	1.4434	.9837	.5339	1.8731	.6781
44	.7506	1.5005	.9859	.5453	1.8338	.6974
45	.8522	1.5522	.9873	.5564	1.7973	.7142
46	.9589	1.6145	.9885	.5705	1.7528	.7336
47	1.0605	1.6784	.9903	.5853	1.7087	.7531
48	1.1621	1.7424	.9914	.6009	1.6641	.7715
49	1.2637	1.8080	.9926	.6176	1.6191	.7897
50	1.3449	1.8622	.9927	.6324	1.5813	.8038

NSWC TR 79-153

TABLE A-3 BOUNDARY LAYER PROFILE LISTING
 RUN NO 801265 CONT.

N	Y (CM)	M	TT/TTE	D/DE	T/TE	U/UE
51	1.4262	1.9097	.9938	.6451	1.5502	.8161
52	1.5100	1.9770	.9955	.6635	1.5072	.8331
53	1.6091	2.0465	.9971	.6832	1.4638	.8499
54	1.7158	2.1240	.9985	.7063	1.4159	.8675
55	1.7183	2.1330	.9976	.7097	1.4090	.8690
56	1.7539	2.1645	.9980	.7195	1.3898	.8759
57	1.8326	2.2308	.9988	.7405	1.3504	.8898
58	1.9215	2.2877	.9994	.7592	1.3172	.9012
59	1.9926	2.3481	.9993	.7800	1.2821	.9126
60	2.0790	2.4016	.9991	.7990	1.2515	.9222
61	2.1501	2.4599	.9983	.8207	1.2185	.9320
62	2.2390	2.5190	.9976	.8432	1.1860	.9416
63	2.3482	2.5884	.9965	.8705	1.1488	.9522
64	2.4473	2.6536	.9964	.8960	1.1160	.9622
65	2.5210	2.6947	.9956	.9130	1.0952	.9680
66	2.6251	2.7486	.9969	.9337	1.0710	.9763
67	2.7318	2.7956	.9985	.9515	1.0509	.9837
68	2.8562	2.8339	.9994	.9667	1.0345	.9893
69	2.9934	2.8626	1.0007	.9776	1.0229	.9938
70	3.1610	2.8848	1.0000	.9877	1.0125	.9963
* 71	3.3363	2.9025	.9998	.9955	1.0045	.9985
** 72	3.5446	2.9134	1.0000	1.0000	1.0000	1.0000
73	3.7071	2.9148	1.0024	.9982	1.0018	1.0014
74	3.8443	2.9135	1.0076	.9924	1.0076	1.0038

NSWC TR 79-153

TABLE A-3 BOUNDARY LAYER PROFILE LISTING
RUN NO 812510

X = 1.981E+00 M	ME = 2.908E+00	DEL = 4.329E+00 CM
PO = 1.127E+05 N/M2	DE = 1.069E-01 KG/M3	DSTR = 1.849E+00 CM
TO = 3.162E+02 DEG.K	TE = 1.175E+02 DEG.K	TH = 3.306E-01 CM
PSW = 3.577E+03 N/M2	UE = 6.319E+02 M/S	THF = 5.517E-01 CM
TW = 2.925E+02 N/M2	RE = 8.282E+06 1/M	THH = 3.439E-02 CM
TAUW = 5.100E+00 N/M2	CF = 2.393E-04	RETH = 6.948E+04
K = 1.016E-02 CM	MDOT = 1.465E-01 KG/M2* ϵ S	

N	Y (CM)	M	TT/TTE	D/DE	T/TE	U/UE
1	0.0000	0.0000	.9249	.4018	2.4888	0.0000
2	.0064	.3096	.9081	.4171	2.3978	.1649
3	.0165	.3637	.9069	.4206	2.3776	.1929
4	.0267	.4207	.9079	.4238	2.3595	.2223
5	.0419	.4726	.9076	.4277	2.3379	.2485
6	.0521	.4929	.9080	.4292	2.3302	.2588
7	.0622	.5240	.9085	.4315	2.3174	.2743
8	.0749	.5473	.9095	.4331	2.3091	.2860
9	.0876	.5771	.9120	.4346	2.3008	.3011
10	.0978	.6022	.9119	.4371	2.2878	.3132
11	.1105	.6163	.9111	.4389	2.2786	.3200
12	.1207	.6342	.9128	.4399	2.2734	.3289
13	.1308	.6581	.9130	.4423	2.2609	.3403
14	.1435	.6723	.9129	.4439	2.2530	.3471
15	.1537	.6821	.9146	.4441	2.2517	.3520
16	.1638	.6999	.9158	.4456	2.2444	.3606
17	.1740	.7078	.9161	.4463	2.2406	.3644
18	.1816	.7181	.9163	.4474	2.2353	.3692
19	.1918	.7308	.9176	.4483	2.2308	.3754
20	.2045	.7387	.9193	.4484	2.2304	.3794
21	.2172	.7556	.9209	.4496	2.2241	.3875
22	.2756	.8238	.9231	.4572	2.1871	.4190
23	.3518	.8803	.9252	.4639	2.1555	.4445
24	.4026	.9107	.9262	.4678	2.1377	.4579
25	.4788	.9681	.9302	.4744	2.1079	.4834
26	.5626	1.0183	.9328	.4810	2.0789	.5050
27	.6718	1.0698	.9321	.4900	2.0410	.5256
28	.7988	1.1323	.9371	.4982	2.0071	.5517
29	.9131	1.1893	.9390	.5077	1.9697	.5740
30	1.0071	1.2301	.9423	.5137	1.9465	.5902
31	1.1265	1.2911	.9460	.5238	1.9092	.6135
32	1.2230	1.3454	.9489	.5334	1.8747	.6335
33	1.3043	1.3857	.9509	.5409	1.8488	.6480
34	1.3780	1.4222	.9539	.5472	1.8276	.6613
35	1.3780	1.4229	.9540	.5473	1.8272	.6615
36	1.4592	1.4647	.9572	.5548	1.8024	.6763
37	1.5532	1.5130	.9605	.5640	1.7730	.6928
38	1.6167	1.5587	.9632	.5733	1.7443	.7080
39	1.7082	1.6061	.9669	.5826	1.7164	.7237
40	1.7615	1.6352	.9682	.5891	1.6976	.7327
41	1.8326	1.6779	.9709	.5983	1.6714	.7460
42	1.9164	1.7366	.9746	.6113	1.6359	.7639
43	2.0028	1.7938	.9773	.6250	1.6001	.7804
44	2.0790	1.8567	.9802	.6405	1.5612	.7979
45	2.1933	1.9359	.9815	.6624	1.5097	.8180
46	2.3152	2.0120	.9860	.6821	1.4661	.8379
47	2.4168	2.0804	.9883	.7015	1.4255	.8542
48	2.5565	2.1885	.9918	.7336	1.3630	.8787
49	2.6784	2.2663	.9953	.7569	1.3212	.8959
50	2.8080	2.3625	.9972	.7887	1.2679	.9149

NSWC TR 79-153

TABLE A-3 BOUNDARY LAYER PROFILE LISTING
RUN NO 812510 CONT.

N	Y (CM)	M	TT/TTE	D/DE	T/TE	U/UE
51	3.1585	2.6074	1.0023	.8750	1.1429	.9587
52	3.2906	2.6758	1.0035	.9007	1.1103	.9697
53	3.4404	2.7644	1.0036	.9362	1.0681	.9826
54	3.5801	2.8162	1.0028	.9583	1.0435	.9894
55	3.7122	2.8538	1.0013	.9757	1.0249	.9936
56	4.0069	2.8896	1.0010	.9913	1.0088	.9982
* 57	4.3294	2.9077	1.0000	1.0000	1.0000	1.0000
58	4.6495	2.9117	.9991	1.0027	.9973	1.0000
59	4.8959	2.9127	.9993	1.0029	.9971	1.0003
60	5.2261	2.9119	.9996	1.0022	.9978	1.0003
61	5.4674	2.9092	.9998	1.0008	.9992	1.0001
62	5.7112	2.9074	1.0004	.9995	1.0005	1.0002
63	6.3462	2.9045	1.0000	.9987	1.0013	.9996
64	7.1209	2.9118	1.0007	1.0010	.9990	1.0009
65	7.6060	2.9057	1.0008	.9984	1.0016	1.0001
66	7.8905	2.8997	1.0009	.9956	1.0044	.9994

NSWC TR 79-153

TABLE A-3 BOUNDARY LAYER PROFILE LISTING
RUN NO 802031

X = 1.981E+00 M ME = 2.937E+00 DEL = 2.590E+00 CM
 PO = 4.132E+05 N/M2 DE = 3.793E-01 KG/M3 DSTR = 8.632E-01 CM
 TO = 3.138E+02 DEG.K TE = 1.152E+02 DEG.K TH = 1.700E-01 CM
 PSW = 1.248E+04 N/M2 UE = 6.318E+02 M/S THE = 3.029E-01 CM
 TW = 3.008E+02 N/M2 RE = 2.999E+07 1/M THH = 1.218E-02 CM
 TAUW = 1.362E+02 N/M2 CF = 1.800E-03 RETH = 1.294E+05
 K = 3.302E-02 CM MDOT = 0. KG/M2*5

N	Y (CM)	M	TT/TTE	D/DE	T/TE	U/UE
1	0.0000	0.0000	.9585	.3828	2.6121	0.0000
2	.0064	.7503	.9668	.4223	2.3682	.3931
3	.0140	.7857	.9664	.4266	2.3443	.4096
4	.0318	.9056	.9688	.4409	2.2682	.4644
5	.0470	.9786	.9695	.4510	2.2175	.4962
6	.0648	1.0546	.9716	.4616	2.1662	.5285
7	.0800	1.1058	.9725	.4696	2.1295	.5494
8	.0978	1.1673	.9749	.4790	2.0878	.5743
9	.1156	1.2119	.9762	.4863	2.0563	.5917
10	.1359	1.2586	.9769	.4946	2.0219	.6093
11	.1511	1.2840	.9776	.4991	2.0036	.6188
12	.1892	1.3345	.9773	.5092	1.9638	.6368
13	.2070	1.3746	.9779	.5170	1.9341	.6509
14	.2070	1.3785	.9774	.5181	1.9301	.6520
15	.2400	1.4136	.9778	.5252	1.9039	.6641
16	.2959	1.4797	.9786	.5392	1.8547	.6861
17	.3493	1.5313	.9789	.5507	1.8160	.7026
18	.4407	1.5991	.9803	.5658	1.7676	.7238
19	.5093	1.6575	.9814	.5793	1.7261	.7414
20	.5093	1.6547	.9801	.5794	1.7258	.7401
21	.5169	1.6691	.9792	.5835	1.7138	.7439
22	.6083	1.7390	.9806	.6005	1.6653	.7641
23	.7252	1.8216	.9830	.6210	1.6103	.7870
24	.8928	1.9429	.9863	.6529	1.5316	.8187
25	1.0147	2.0468	.9879	.6827	1.4649	.8434
26	1.1646	2.1488	.9892	.7135	1.4016	.8662
27	1.3424	2.2920	.9928	.7579	1.3194	.8964
28	1.4440	2.3763	.9935	.7865	1.2715	.9123
29	1.5685	2.4707	.9950	.8190	1.2210	.9295
30	1.6701	2.5549	.9962	.8492	1.1776	.9440
31	2.0206	2.7906	.9992	.9392	1.0647	.9804
32	2.2339	2.8832	.9996	.9773	1.0232	.9930
33	2.3990	2.9157	.9996	.9912	1.0089	.9971
* 34	2.5895	2.9371	1.0000	1.0000	1.0000	1.0000
35	2.7800	2.9483	.9996	1.0053	.9948	1.0012
36	2.8893	2.9526	.9990	1.0077	.9924	1.0015
37	3.0112	2.9528	.9978	1.0090	.9911	1.0009
38	3.3287	2.9354	.9963	1.0030	.9970	.9979
39	3.5141	2.9249	.9955	.9993	1.0007	.9962
40	3.6767	2.9213	.9949	.9984	1.0017	.9954
41	3.9434	2.9222	.9943	.9994	1.0006	.9953
42	4.1618	2.9249	.9937	1.0011	.9989	.9953
43	4.3726	2.9274	.9931	1.0027	.9973	.9954
44	4.6596	2.9310	.9920	1.0055	.9946	.9952
45	4.9467	2.9296	.9914	1.0054	.9946	.9947
46	5.0330	2.9279	.9908	1.0053	.9947	.9942
47	5.3810	2.9236	.9895	1.0048	.9952	.9930

NSWC TR 79-153

TABLE A-3 BOUNDARY LAYER PROFILE LISTING
RUN NO 802071

X = 1.981E+00 M ME = 2.932E+00 DEL = 2.567E+00 CM
 PU = 2.090E+05 N/M2 DE = 1.880E-01 KG/M3 DSTR = 9.225E-01 CM
 TO = 3.186E+02 DEG.K TE = 1.172E+02 DEG.K TH = 1.744E-01 CM
 PSW = 6.296E+03 N/M2 UE = 6.362E+02 M/S THE = 3.084E-01 CM
 TW = 2.980E+02 N/M2 RE = 1.471E+07 1/M THH = 1.444E-03 CM
 TAUW = 6.549E+01 N/M2 CF = 1.723E-03 RETH = 6.510E+04
 K = 3.302E-02 CM MDOT = 0. KG/M2*S

N	Y (CM)	M	TT/TTE	D/DE	T/TE	U/UE
1	0.0000	0.0000	.9354	.3932	2.5433	0.0000
2	.0064	.7571	.9348	.4385	2.2803	.3900
3	.0165	.7966	.9377	.4420	2.2624	.4087
4	.0216	.8371	.9377	.4472	2.2360	.4270
5	.0267	.8687	.9373	.4516	2.2143	.4409
6	.0445	.9718	.9427	.4639	2.1558	.4867
7	.0622	1.0354	.9472	.4716	2.1206	.5143
8	.0749	1.0712	.9496	.4762	2.0998	.5295
9	.0902	1.1129	.9505	.4828	2.0712	.5463
10	.1080	1.1532	.9545	.4878	2.0499	.5632
11	.1232	1.1903	.9567	.4934	2.0269	.5780
12	.1359	1.2210	.9583	.4982	2.0071	.5901
13	.1511	1.2515	.9613	.5025	1.9902	.6022
14	.1715	1.2753	.9614	.5070	1.9725	.6109
15	.1867	1.2949	.9606	.5113	1.9559	.6177
16	.2146	1.3355	.9618	.5188	1.9275	.6325
17	.2705	1.4017	.9631	.5320	1.8798	.6555
18	.3594	1.4936	.9652	.5511	1.8146	.6863
19	.4458	1.5558	.9688	.5634	1.7749	.7070
20	.5271	1.6148	.9730	.5751	1.7387	.7263
21	.6083	1.6746	.9768	.5877	1.7014	.7451
22	.7023	1.7463	.9792	.6047	1.6537	.7660
23	.7023	1.7459	.9809	.6035	1.6569	.7666
24	.8192	1.8315	.9840	.6246	1.6011	.7905
25	.9335	1.9165	.9869	.6464	1.5469	.8131
26	1.0503	2.0090	.9923	.6698	1.4929	.8373
27	1.1621	2.0877	.9959	.6913	1.4466	.8565
28	1.2738	2.1693	1.0002	.7139	1.4009	.8758
29	1.3957	2.2627	1.0041	.7414	1.3489	.8964
30	1.5126	2.3601	1.0067	.7724	1.2947	.9160
31	1.6116	2.4351	1.0091	.7968	1.2551	.9306
32	1.7259	2.5149	1.0111	.8239	1.2138	.9451
33	1.8174	2.5784	1.0136	.8454	1.1829	.9566
34	1.9291	2.6629	1.0140	.8772	1.1401	.9699
35	2.0384	2.7344	1.0136	.9055	1.1044	.9802
36	2.1298	2.7932	1.0111	.9314	1.0736	.9872
37	2.2416	2.8484	1.0123	.9529	1.0495	.9953
38	2.3660	2.8916	1.0079	.9752	1.0254	.9988
39	2.4498	2.9135	1.0060	.9863	1.0139	1.0007
* 40	2.5667	2.9316	1.0000	1.0000	1.0000	1.0000
41	2.7216	2.9448	1.0028	1.0029	.9971	1.0031
42	2.8766	2.9512	1.0030	1.0055	.9945	1.0039
43	3.0391	2.9568	1.0010	1.0099	.9902	1.0036
44	3.2398	2.9553	1.0022	1.0081	.9920	1.0041
45	3.4404	2.9473	1.0048	1.0020	.9980	1.0044
46	3.6995	2.9472	1.0063	1.0005	.9995	1.0051
47	3.9307	2.9512	1.0064	1.0020	.9980	1.0057
48	4.2837	2.9431	1.0060	.9990	1.0011	1.0044
49	4.6139	2.9286	1.0081	.9906	1.0095	1.0037
50	5.0457	2.9212	1.0090	.9866	1.0136	1.0032

NSWC TR 79-153

TABLE A-3 BOUNDARY LAYER PROFILE LISTING
RUN NO 802072

X = 1.981E+00 M	ME = 2.951E+00	DEL = 2.866E+00 CM
PO = 1.040E+05 N/M2	DE = 9.635E-02 KG/M3	DSTR = 9.591E-01 CM
TO = 3.171E+02 DFG.K	TE = 1.157E+02 DEG.K	TH = 1.840E-01 CM
PSW = 3.170E+03 N/M2	UE = 6.361E+02 M/S	THE = 3.261E-01 CM
TW = 2.954E+02 N/M2	RE = 7.636E+06 1/M	THH = 7.733E-03 CM
TAUW = 3.051E+01 N/M2	CF = 1.567E-03	RETH = 3.566E+04
K = 3.302E-02 CM	MDOT = 0.	KG/M2*S

N	Y (CM)	M	TT/TTE	D/DE	T/TE	U/UE
1	0.0000	0.0000	.9316	.3916	2.5537	0.0000
2	.0064	.6904	.9289	.4302	2.3247	.3567
3	.0064	.7271	.9330	.4323	2.3130	.3748
4	.0064	.7274	.9297	.4339	2.3046	.3743
5	.0114	.7674	.9258	.4404	2.2704	.3919
6	.0165	.7983	.9239	.4452	2.2464	.4055
7	.0191	.8342	.9250	.4493	2.2259	.4218
8	.0241	.8751	.9247	.4549	2.1981	.4397
9	.0318	.9267	.9303	.4595	2.1764	.4633
10	.0394	.9619	.9314	.4641	2.1545	.4785
11	.0445	1.0051	.9329	.4701	2.1274	.4969
12	.0546	1.0367	.9352	.4739	2.1100	.5104
13	.0775	1.1090	.9375	.4848	2.0626	.5398
14	.0978	1.1641	.9409	.4928	2.0292	.5620
15	.1181	1.2023	.9442	.4981	2.0077	.5774
16	.1334	1.2323	.9471	.5022	1.9914	.5893
17	.1511	1.2639	.9472	.5082	1.9679	.6009
18	.1740	1.2985	.9496	.5137	1.9466	.6140
19	.1969	1.3298	.9508	.5194	1.9254	.6254
20	.2248	1.3631	.9535	.5247	1.9057	.6377
21	.2527	1.3865	.9553	.5287	1.8914	.6462
22	.2858	1.4165	.9562	.5346	1.8704	.6566
23	.3315	1.4587	.9602	.5416	1.8463	.6717
24	.3543	1.4762	.9616	.5447	1.8357	.6779
25	.4178	1.5330	.9634	.5566	1.7965	.6964
26	.6312	1.6950	.9727	.5906	1.6933	.7475
27	.7531	1.7818	.9776	.6101	1.6392	.7731
28	.9258	1.9083	.9838	.6408	1.5604	.8079
29	1.0452	1.9844	.9863	.6612	1.5125	.8271
30	1.1443	2.0586	.9913	.6799	1.4708	.8461
31	1.3195	2.1858	.9976	.7150	1.3986	.8761
32	1.4237	2.2675	1.0004	.7396	1.3521	.8936
33	1.5481	2.3578	1.0028	.7682	1.3017	.9117
34	1.6472	2.4321	1.0041	.7931	1.2608	.9255
35	1.7894	2.5317	1.0077	.8261	1.2105	.9440
36	1.8967	2.6057	1.0094	.8522	1.1735	.9566
37	2.0104	2.6760	1.0088	.8795	1.1370	.9671
38	2.3635	2.8694	1.0068	.9590	1.0428	.9931
39	2.4473	2.8936	1.0043	.9715	1.0293	.9949
40	2.5946	2.9266	1.0036	.9862	1.0140	.9988
* 41	2.8664	2.9506	1.0000	1.0000	1.0000	1.0000
42	3.1229	2.9569	1.0005	1.0023	.9977	1.0010
43	3.2652	2.9498	1.0013	.9983	1.0017	1.0005
44	3.4303	2.9413	.9997	.9963	1.0037	.9987
45	3.5979	2.9366	1.0012	.9928	1.0072	.9989
46	3.8468	2.9420	1.0022	.9940	1.0060	1.0001
47	4.0450	2.9436	1.0029	.9941	1.0059	1.0006
48	4.3269	2.9326	1.0046	.9877	1.0124	1.0001
49	4.5758	2.9211	1.0050	.9825	1.0178	.9988
50	4.9086	2.9189	1.0039	.9826	1.0177	.9980

NSWC TR 79-153

TABLE A-3 BOUNDARY LAYER PROFILE LISTING
RUN NO 802073

X = 1.981E+00 M	ME = 2.887E+00	DEL = 2.907E+00 CM
PO = 5.192E+04 N/M2	DE = 4.919E-02 KG/M3	DSTR = 1.009E+00 CM
TO = 3.188E+02 DEG.K	TE = 1.195E+02 DEG.K	TH = 2.019E-01 CM
PSW = 1.652E+03 N/M2	UE = 6.327E+02 M/S	THE = 3.579E-02 CM
TW = 2.935E+02 N/M2	RE = 3.755E+06 1/M	THH = 1.240E-02 CM
TAUW = 1.452E+01 N/M2	CF = 1.476E-03	RETH = 1.924E+04
K = 3.302E-02 CM	MDOT = 0.	KG/M2*S

N	Y (CM)	M	TT/TE	D/DE	T/TE	U/UE
1	0.0000	0.0000	.9206	.4073	2.4553	0.0000
2	.0064	.5191	.9181	.4304	2.3234	.2741
3	.0089	.5504	.9181	.4331	2.3087	.2897
4	.0140	.6333	.9195	.4405	2.2702	.3305
5	.0191	.6697	.9209	.4437	2.2538	.3482
6	.0241	.7088	.9224	.4473	2.2354	.3670
7	.0292	.7526	.9241	.4517	2.2138	.3879
8	.0318	.8101	.9264	.4579	2.1840	.4147
9	.0368	.8463	.9286	.4616	2.1663	.4314
10	.0419	.9012	.9323	.4675	2.1390	.4565
11	.0495	.9320	.9333	.4716	2.1206	.4701
12	.0495	.9332	.9344	.4712	2.1224	.4709
13	.0521	.9596	.9360	.4744	2.1080	.4826
14	.0546	.9790	.9375	.4766	2.0981	.4912
15	.0978	1.1697	.9419	.5070	1.9723	.5690
16	.1537	1.2752	.9461	.5252	1.9041	.6095
17	.2070	1.3151	.9484	.5321	1.8793	.6244
18	.2426	1.3667	.9506	.5418	1.8457	.6431
19	.2985	1.4014	.9535	.5477	1.8258	.6559
20	.3442	1.4387	.9559	.5546	1.8030	.6691
21	.4128	1.4993	.9601	.5661	1.7664	.6902
22	.4864	1.5502	.9640	.5759	1.7365	.7076
23	.5525	1.5845	.9666	.5827	1.7161	.7190
24	.6287	1.6383	.9698	.5942	1.6830	.7362
25	.7201	1.7050	.9735	.6091	1.6418	.7567
26	.8166	1.7602	.9759	.6223	1.6069	.7729
27	.9004	1.8157	.9794	.6353	1.5742	.7891
28	1.0528	1.9087	.9844	.6584	1.5188	.8148
29	1.1316	1.9651	.9870	.6733	1.4852	.8295
30	1.3805	2.1295	.9935	.7197	1.3895	.8695
31	1.5507	2.2450	.9986	.7539	1.3264	.8956
32	1.6370	2.2981	1.0008	.7704	1.2980	.9069
33	1.6370	2.3018	.9996	.7726	1.2944	.9071
34	1.7488	2.3704	1.0016	.7951	1.2577	.9208
35	1.8225	2.4164	1.0035	.8100	1.2346	.9300
36	1.8860	2.4575	1.0041	.8245	1.2128	.9375
37	1.9520	2.4986	1.0044	.8394	1.1913	.9446
38	2.0434	2.5529	1.0062	.8583	1.1650	.9545
39	2.1323	2.6171	1.0071	.8823	1.1334	.9651
40	2.2263	2.6657	1.0057	.9027	1.1078	.9718
41	2.3254	2.7182	1.0066	.9230	1.0834	.9800
42	2.4270	2.7627	1.0060	.9417	1.0619	.9861
43	2.5337	2.8061	1.0056	.9600	1.0416	.9920
44	2.6378	2.8387	1.0038	.9755	1.0251	.9955
45	2.7750	2.8683	1.0000	.9920	1.0081	.9975
46	2.9070	2.8870	1.0000	1.0000	1.0000	1.0000
47	3.0975	2.8998	.9978	1.0078	.9923	1.0006
48	3.2906	2.9024	.9981	1.0086	.9915	1.0010
49	3.4531	2.8979	.9987	1.0060	.9940	1.0007
50	3.6741	2.8957	.9990	1.0048	.9952	1.0006

NSWC TR 79-153

TABLE A-3 BOUNDARY LAYER PROFILE LISTING
RUN NO 802073 CONT.

N	Y (CM)	M	TT/TTE	D/DE	T/TE	U/UE
51	3.8468	2.8960	.9981	1.0058	.9942	1.0002
52	4.0424	2.8974	1.0002	1.0043	.9957	1.0014
53	4.2126	2.8938	1.0009	1.0020	.9980	1.0013
54	4.3980	2.8861	1.0016	.9980	1.0020	1.0007
55	4.5961	2.8758	1.0004	.9947	1.0053	.9987
56	4.7968	2.8716	1.0015	.9919	1.0082	.9987
57	4.9848	2.8686	1.0016	.9905	1.0096	.9984
58	5.2489	2.8661	1.0045	.9865	1.0136	.9995
59	5.4470	2.8677	1.0049	.9868	1.0134	.9999
60	5.6883	2.8778	1.0060	.9901	1.0100	1.0018

NSWC TR 79-153

TABLE A-3 BOUNDARY LAYER PROFILE LISTING
RUN NO 802032

X = 1.981E+00 M	ME = 2.928E+00	DEL = 2.544E+00 CM
PO = 4.124E+05 N/M2	DE = 3.742E-01 KG/M3	DSTR = 8.712E-01 CM
TO = 3.166E+02 DEG.K	TE = 1.166E+02 DEG.K	TH = 1.738E-01 CM
PSW = 1.248E+04 N/M2	UE = 6.339E+02 M/S	THE = 3.089E-01 CM
TW = 2.955E+02 N/M2	RE = 2.931E+07 1/M	THH = 1.598E-02 CM
TAUW = 1.328E+02 N/M2	CF = 1.768E-03	RETH = 1.293E+05
K = 3.302E-02 CM	MDOT = 1.465E-02 KG/M2*S	

N	Y (CM)	M	TT/TTE	D/DE	T/TE	U/UE
1	0.0000	0.0000	.9332	.3947	2.5335	0.0000
2	.0064	.7423	.9451	.4327	2.3111	.3854
3	.0114	.7473	.9459	.4330	2.3097	.3879
4	.0114	.7448	.9464	.4324	2.3125	.3868
5	.0114	.7458	.9464	.4325	2.3120	.3873
6	.0114	.7411	.9469	.4318	2.3160	.3852
7	.0140	.7445	.9458	.4327	2.3113	.3865
8	.0140	.7429	.9469	.4320	2.3151	.3860
9	.0191	.7359	.9467	.4312	2.3189	.3827
10	.0292	.8342	.9477	.4428	2.2584	.4282
11	.0368	.8896	.9505	.4489	2.2278	.4535
12	.0521	.9578	.9532	.4573	2.1865	.4837
13	.0724	1.0488	.9561	.4700	2.1275	.5224
14	.0800	1.0875	.9579	.4755	2.1030	.5386
15	.0902	1.1168	.9589	.4800	2.0834	.5505
16	.1156	1.1874	.9606	.4916	2.0341	.5784
17	.1435	1.2505	.9621	.5026	1.9895	.6024
18	.1613	1.2871	.9638	.5088	1.9653	.6163
19	.1842	1.3191	.9643	.5149	1.9420	.6278
20	.2019	1.3461	.9640	.5206	1.9209	.6372
21	.2273	1.3853	.9647	.5284	1.8926	.6508
22	.2502	1.4093	.9655	.5331	1.8759	.6592
23	.2654	1.4295	.9686	.5357	1.8666	.6670
24	.2807	1.4464	.9685	.5395	1.8537	.6726
25	.2985	1.4597	.9684	.5425	1.8434	.6768
26	.3213	1.4811	.9691	.5469	1.8286	.6840
27	.3670	1.5226	.9711	.5552	1.8011	.6979
28	.3772	1.5365	.9703	.5589	1.7893	.7019
29	.3797	1.5403	.9717	.5590	1.7889	.7036
30	.4305	1.5775	.9723	.5674	1.7623	.7152
31	.4966	1.6295	.9734	.5794	1.7258	.7311
32	.5728	1.6888	.9759	.5928	1.6869	.7491
33	.6541	1.7499	.9766	.6082	1.6442	.7663
34	.7303	1.8083	.9784	.6227	1.6059	.7826
35	.7988	1.8580	.9793	.6359	1.5727	.7958
36	.8700	1.9114	.9798	.6507	1.5368	.8093
37	.9436	1.9689	.9815	.6663	1.5008	.8238
38	1.0173	2.0263	.9837	.6820	1.4663	.8380
39	1.1138	2.0914	.9867	.6999	1.4288	.8538
40	1.1722	2.1376	.9887	.7131	1.4024	.8645
41	1.2535	2.2028	.9899	.7333	1.3637	.8785
42	1.3322	2.2610	.9902	.7524	1.3292	.8902
43	1.4008	2.3119	.9903	.7696	1.2994	.9000
44	1.5431	2.4231	.9925	.8069	1.2392	.9212
45	1.6193	2.4835	.9940	.8277	1.2082	.9323
46	1.6777	2.5494	.9961	.8505	1.1758	.9441
47	1.7666	2.6088	.9963	.8730	1.1455	.9536
48	1.9774	2.7527	.9995	.9271	1.0786	.9764
49	2.0866	2.8133	1.0001	.9514	1.0511	.9851
50	2.1933	2.8582	.9998	.9704	1.0305	.9909

NSWC TR 79-153

TABLE A-3 BOUNDARY LAYER PROFILE LISTING
RUN NO 802032 CONT.

N	Y(CM)	M	TT/TTE	D/DE	T/TE	U/UE
51	2.1958	2.8579	1.0010	.9691	1.0319	.9915
52	2.2924	2.8869	.9998	.9826	1.0178	.9946
53	2.4143	2.9094	.9996	.9924	1.0077	.9975
* 54	2.5438	2.9281	1.0000	1.0000	1.0000	1.0000
55	2.6437	2.9398	.9996	1.0054	.9946	1.0013
56	2.8461	2.9479	.9998	1.0088	.9913	1.0024
57	3.0798	2.9488	.9998	1.0092	.9909	1.0025
58	3.3617	2.9266	.9993	1.0000	1.0000	.9995
59	3.6716	2.9197	.9987	.9977	1.0023	.9983
60	3.9154	2.9201	.9975	.9991	1.0009	.9977
61	4.1694	2.9231	.9957	1.0022	.9978	.9972
62	4.4082	2.9256	.9945	1.0044	.9956	.9970
63	4.6317	2.9279	.9958	1.0042	.9958	.9979
64	4.8882	2.9282	.9952	1.0049	.9951	.9976
65	5.1626	2.9216	.9939	1.0033	.9967	.9961
66	5.5893	2.9245	.9933	1.0052	.9948	.9962
67	5.8712	2.9291	.9934	1.0071	.9930	.9968
68	6.2243	2.9228	.9915	1.0062	.9938	.9951
69	6.4681	2.9239	.9886	1.0098	.9903	.9938

NSWC TR 79-153

TABLE A-3 BOUNDARY LAYER PROFILE LISTING
RUN NO 802074

X = 1.981E+00 M	ME = 2.940E+00	DEL = 2.877E+00 CM
PO = 2.073E+05 N/M2	DE = 1.899E-01 KG/M3	DSTR = 9.715E-01 CM
TO = 3.184E+02 DEG.K	TE = 1.167E+02 DEG.K	TH = 1.841E-01 CM
PSW = 6.295E+03 N/M2	UE = 6.366E+02 M/S	THE = 3.247E-01 CM
TW = 2.912E+02 N/M2	RE = 1.493E+07 1/M	THH = 5.135E-03 CM
TAUW = 6.170E+01 N/M2	CF = 1.605E-03	RETH = 6.978E+04
K = 3.302E-02 CM	MDOT = 1.465E-02 KG/M2*S	

N	Y (CM)	M	TT/TTE	D/DE	T/TTE	U/UE
1	0.0000	0.0000	.9147	.4006	2.4961	0.0000
2	.0064	.7134	.9210	.4384	2.2811	.3665
3	.0140	.7672	.9213	.4446	2.2492	.3914
4	.0216	.8185	.9208	.4513	2.2158	.4144
5	.0267	.8478	.9211	.4550	2.1976	.4275
6	.0343	.8882	.9239	.4592	2.1775	.4458
7	.0445	.9252	.9276	.4627	2.1611	.4626
8	.0495	.9511	.9298	.4654	2.1486	.4742
9	.0572	.9841	.9329	.4689	2.1327	.4888
10	.0648	1.0045	.9356	.4707	2.1243	.4980
11	.0724	1.0212	.9375	.4724	2.1167	.5053
12	.0724	1.0228	.9366	.4721	2.1182	.5063
13	.1257	1.1638	.9451	.4928	2.0293	.5639
14	.1765	1.2560	.9508	.5071	1.9722	.5999
15	.2350	1.3398	.9543	.5219	1.9162	.6308
16	.3188	1.4176	.9586	.5359	1.8660	.6586
17	.4001	1.4772	.9627	.5468	1.8289	.6795
18	.4940	1.5515	.9697	.5598	1.7863	.7053
19	.5804	1.6207	.9736	.5741	1.7417	.7275
20	.6668	1.6914	.9773	.5895	1.6964	.7493
21	.8141	1.7938	.9811	.6139	1.6288	.7787
22	.9487	1.8877	.9856	.6368	1.5703	.8046
23	1.0452	1.9453	.9883	.6514	1.5350	.8198
24	1.1265	2.0136	.9924	.6687	1.4955	.8375
25	1.2281	2.0897	.9964	.6890	1.4514	.8563
26	1.3627	2.2019	.9994	.7222	1.3846	.8813
27	1.5075	2.2998	1.0044	.7508	1.3320	.9028
28	1.6523	2.4181	1.0084	.7884	1.2683	.9263
29	1.8021	2.5263	1.0090	.8268	1.2094	.9450
30	1.9088	2.6054	1.0109	.8547	1.1700	.9586
31	2.0282	2.6854	1.0118	.8845	1.1306	.9712
32	2.1146	2.7526	1.0103	.9124	1.0960	.9802
33	2.2644	2.8282	1.0087	.9445	1.0588	.9898
34	2.4346	2.8857	1.0049	.9720	1.0288	.9955
35	2.5794	2.9184	1.0024	.9883	1.0118	.9985
* 36	2.8766	2.9401	1.0000	1.0000	1.0000	1.0000
37	3.0747	2.9466	1.0010	1.0018	.9982	1.0013
38	3.3566	2.9405	1.0014	.9988	1.0012	1.0008
39	3.5268	2.9345	1.0012	.9964	1.0037	.9999
40	3.6513	2.9346	1.0024	.9952	1.0048	1.0005
41	3.8367	2.9378	1.0030	.9961	1.0039	1.0012
42	4.0323	2.9407	1.0046	.9957	1.0043	1.0024
43	4.3066	2.9353	1.0032	.9947	1.0053	1.0010
44	4.6038	2.9204	1.0026	.9889	1.0112	.9989
45	4.8933	2.9172	1.0041	.9861	1.0140	.9992
46	5.1295	2.9105	1.0035	.9839	1.0164	.9980
47	5.4166	2.9111	1.0039	.9838	1.0165	.9983
48	5.6934	2.9231	1.0042	.9885	1.0116	1.0000

NSWC TR 79-153

TABLE A-3 BOUNDARY LAYER PROFILE LISTING
RUN NO R02075

X = 1.981E+00 M ME = 2.947E+00 DEL = 3.065E+00 CM
 PO = 1.040E+05 N/M2 DE = 9.576E-02 KG/M3 DSTR = 1.043E+00 CM
 TO = 3.210E+02 DEG.K TE = 1.173E+02 DEG.K TH = 1.970E-01 CM
 PSW = 3.190E+03 N/M2 UE = 6.398E+02 M/S THE = 3.466E-01 CM
 TW = 3.001E+02 N/M2 RE = 7.529E+06 1/M THH = 6.840E-03 CM
 TAUW = 2.611E+01 N/M2 CF = 1.333E-03 RETH = 3.764E+04
 K = 3.302E-02 CM MDOT = 1.465E-02 KG/M2*%S

N	Y (CM)	M	TT/TTE	D/DE	T/TE	U/UE
1	0.0000	0.0000	.9350	.3907	2.5593	0.0000
2	.0064	.6366	.9246	.4272	2.3410	.3305
3	.0114	.7150	.9332	.4315	2.3175	.3693
4	.0292	.8305	.9286	.4477	2.2336	.4211
5	.0343	.8721	.9300	.4526	2.2096	.4399
6	.0419	.9119	.9318	.4573	2.1868	.4575
7	.0495	.9394	.9329	.4607	2.1705	.4696
8	.0597	.9852	.9339	.4672	2.1406	.4891
9	.0800	1.0444	.9373	.4748	2.1060	.5143
10	.0876	1.0635	.9377	.4777	2.0933	.5221
11	.0978	1.0839	.9382	.4809	2.0794	.5303
12	.1080	1.1056	.9398	.4838	2.0670	.5394
13	.1486	1.1804	.9444	.4947	2.0215	.5695
14	.1918	1.2414	.9479	.5042	1.9833	.5932
15	.2273	1.2837	.9506	.5110	1.9569	.6093
16	.2883	1.3417	.9542	.5208	1.9203	.6309
17	.3467	1.3925	.9578	.5294	1.8891	.6494
18	.4001	1.4404	.9604	.5383	1.8578	.6662
19	.4509	1.4830	.9623	.5466	1.8294	.6806
20	.5017	1.5119	.9639	.5523	1.8106	.6903
21	.5652	1.5590	.9671	.5614	1.7812	.7060
22	.7125	1.6636	.9731	.5833	1.7145	.7391
23	.7836	1.7153	.9758	.5947	1.6814	.7547
24	.8471	1.7598	.9783	.6048	1.6535	.7678
25	.9030	1.8056	.9802	.6158	1.6240	.7808
26	.9766	1.8527	.9835	.6265	1.5962	.7942
27	1.0605	1.9164	.9880	.6414	1.5590	.8119
28	1.1341	1.9670	.9896	.6548	1.5271	.8248
29	1.2205	2.0189	.9919	.6686	1.4957	.8378
30	1.3195	2.0969	.9960	.6894	1.4506	.8569
31	1.4161	2.1676	.9984	.7098	1.4089	.8730
32	1.5405	2.2577	1.0031	.7355	1.3596	.8933
33	1.6396	2.3373	1.0046	.7611	1.3140	.9091
34	1.7666	2.4231	1.0068	.7890	1.2674	.9256
35	1.8352	2.4758	1.0099	.8053	1.2418	.9362
36	1.9114	2.5367	1.0084	.8286	1.2069	.9456
37	1.9952	2.5890	1.0099	.8467	1.1811	.9547
38	2.0561	2.6372	1.0112	.8639	1.1576	.9627
39	2.1476	2.6910	1.0098	.8858	1.1289	.9701
40	2.2492	2.7549	1.0096	.9112	1.0975	.9793
41	2.3457	2.8041	1.0077	.9326	1.0722	.9852
42	2.4752	2.8569	1.0069	.9551	1.0470	.9919
43	2.6353	2.9033	1.0041	.9772	1.0233	.9965
44	2.8283	2.9319	1.0015	.9920	1.0081	.9988
* 45	3.0645	2.9472	1.0000	1.0000	1.0000	1.0000
46	3.4455	2.9383	1.0002	.9960	1.0040	.9990
47	3.6411	2.9312	1.0000	.9931	1.0069	.9980
48	3.9408	2.9357	1.0012	.9939	1.0062	.9992
49	4.2482	2.9339	1.0012	.9931	1.0070	.9990
50	4.6190	2.9177	1.0044	.9830	1.0172	.9985

NSWC TR 79-153

TABLE A-3 BOUNDARY LAYER PROFILE LISTING
RUN NO 802076

X = 1.981E+00 M ME = 2.905E+00 DEL = 3.044E+00 CM
 PO = 5.212E+04 N/M2 DE = 4.967E-02 KG/M3 DSTR = 1.172E+00 CM
 TO = 3.186E+02 DEG.K TE = 1.185E+02 DEG.K TH = 2.292E-01 CM
 PSW = 1.652E+03 N/M2 UE = 6.340E+02 M/S THE = 4.004E-01 CM
 TW = 2.935E+02 N/M2 RE = 3.831E+06 1/M THH = 1.779E-02 CM
 TAUW = 1.104E+01 N/M2 CF = 1.107E-03 HETH = 2.229E+04
 K = 3.302E-02 CM MDOT = 1.465E-02 KG/M2*S

N	Y (CM)	M	TT/TTE	D/DE	T/TF	U/UE
1	0.0000	0.0000	.9211	.4038	2.4762	0.0000
2	.0064	.4696	.9125	.4256	2.3494	.2478
3	.0064	.4868	.9188	.4241	2.3580	.2573
4	.0064	.5103	.9193	.4257	2.3488	.2692
5	.0140	.5573	.9190	.4299	2.3259	.2926
6	.0216	.6110	.9194	.4348	2.2999	.3189
7	.0292	.7273	.9213	.4465	2.2396	.3746
8	.0419	.8073	.9224	.4558	2.1938	.4116
9	.0495	.8546	.9230	.4619	2.1650	.4328
10	.0648	.9219	.9244	.4708	2.1239	.4625
11	.0749	.9534	.9256	.4750	2.1054	.4762
12	.0902	.9949	.9268	.4809	2.0796	.4938
13	.1029	1.0193	.9279	.4842	2.0652	.5042
14	.1130	1.0428	.9276	.4883	2.0480	.5137
15	.1308	1.0721	.9278	.4931	2.0280	.5255
16	.1410	1.0899	.9275	.4964	2.0146	.5324
17	.1562	1.1155	.9280	.5006	1.9975	.5426
18	.1715	1.1335	.9289	.5034	1.9866	.5499
19	.1791	1.1426	.9289	.5050	1.9801	.5534
20	.1892	1.1533	.9285	.5072	1.9715	.5574
21	.1969	1.1684	.9292	.5097	1.9621	.5633
22	.2578	1.2281	.9324	.5193	1.9257	.5866
23	.3188	1.2841	.9369	.5280	1.8941	.6083
24	.3823	1.3388	.9416	.5367	1.8633	.6290
25	.4585	1.4009	.9453	.5480	1.8249	.6514
26	.5499	1.4612	.9492	.5593	1.7880	.6725
27	.6515	1.5258	.9534	.5719	1.7487	.6945
28	.7963	1.6124	.9605	.5886	1.6988	.7234
29	.8827	1.6667	.9643	.6001	1.6665	.7406
30	1.0147	1.7344	.9696	.6145	1.6273	.7615
31	1.0147	1.7360	.9708	.6141	1.6283	.7625
32	1.1468	1.8418	.9766	.6393	1.5641	.7928
33	1.2840	1.9204	.9810	.6589	1.5177	.8143
34	1.3830	2.0012	.9854	.6799	1.4709	.8354
35	1.5024	2.0645	.9892	.6966	1.4355	.8514
36	1.5989	2.1308	.9935	.7145	1.3996	.8677
37	1.7005	2.1963	.9969	.7331	1.3640	.8829
38	1.7996	2.2639	.9995	.7537	1.3268	.8976
39	1.9317	2.3471	1.0022	.7801	1.2818	.9146
40	2.0688	2.4523	1.0055	.8150	1.2271	.9350
41	2.2162	2.5393	1.0079	.8451	1.1833	.9508
42	2.3482	2.6228	1.0096	.8754	1.1423	.9648
43	2.5870	2.7522	1.0075	.9286	1.0769	.9830
44	2.7115	2.8033	1.0068	.9502	1.0524	.9898
45	2.8613	2.8544	1.0051	.9733	1.0275	.9959
46	2.9451	2.8745	1.0038	.9830	1.0173	.9979
* 47	3.0442	2.8913	1.0018	.9922	1.0079	.9991
** 48	3.1839	2.9053	1.0000	1.0000	1.0000	1.0000
49	3.4252	2.9146	.9992	1.0048	.9952	1.0008
50	3.5751	2.9120	.9997	1.0032	.9969	1.0007

NSWC TR 79-153

TABLE A-3 BOUNDARY LAYER PROFILE LISTING
RUN NO 802076 CONT.

N	Y (CM)	M	TT/TTE	D/DE	T/TE	U/UE
51	3.7705	2.9065	.9992	1.0013	.9987	.9998
52	4.0653	2.9088	1.0011	1.0004	.9996	1.0010
53	4.3371	2.9088	1.0008	1.0007	.9993	1.0008
54	4.4742	2.9076	1.0019	.9991	1.0009	1.0012
55	4.6749	2.8993	1.0023	.9951	1.0050	1.0004
56	4.8908	2.8919	1.0023	.9919	1.0082	.9994
57	5.1727	2.8881	1.0038	.9888	1.0113	.9997
58	5.4623	2.8833	1.0047	.9859	1.0143	.9995
59	5.7061	2.8853	1.0037	.9877	1.0124	.9993
60	6.0008	2.8960	1.0060	.9900	1.0101	1.0018
61	6.2090	2.9000	1.0068	.9910	1.0091	1.0027

NSWC TR 79-153

TABLE A-3 BOUNDARY LAYER PROFILE LISTING
RUN NO 802033

X = 1.981E+00 M	ME = 2.933E+00	DEL = 2.579E+00 CM
PO = 4.129E+05 N/M2	DE = 3.673E-01 KG/M3	DSTR = 9.202E-01 CM
TO = 3.248E+02 DEG.K	TE = 1.194E+02 DEG.K	TH = 1.797E-01 CM
PSW = 1.253E+04 N/M2	UE = 6.424E+02 M/S	THF = 3.186E-01 CM
TW = 3.051E+02 N/M2	RE = 2.850E+07 1/M	THH = 1.248E-02 CM
TAUW = 1.255E+02 N/M2	CF = 1.657E-03	RETH = 1.300E+05
K = 3.302E-02 CM	MDOT = 4.883E-02 KG/M2*S	

N	Y (CM)	M	TT/TTE	D/DE	T/TE	U/UE
1	0.0000	0.0000	.9393	.3913	2.5556	0.0000
2	.0064	.7249	.9572	.4244	2.3565	.3794
3	.0089	.7184	.9564	.4240	2.3586	.3761
4	.0140	.7237	.9566	.4245	2.3558	.3787
5	.0140	.7233	.9560	.4247	2.3546	.3784
6	.0165	.7367	.9559	.4263	2.3460	.3847
7	.0216	.7614	.9562	.4290	2.3312	.3963
8	.0241	.7829	.9569	.4312	2.3193	.4065
9	.0318	.8134	.9575	.4347	2.3006	.4206
10	.0368	.8486	.9588	.4386	2.2802	.4368
11	.0394	.8732	.9591	.4417	2.2642	.4479
12	.0470	.9122	.9606	.4463	2.2406	.4655
13	.0648	.9930	.9626	.4571	2.1875	.5007
14	.0800	1.0504	.9636	.4656	2.1478	.5248
15	.1130	1.1505	.9664	.4810	2.0790	.5656
16	.1308	1.1919	.9675	.4878	2.0499	.5818
17	.1461	1.2252	.9694	.4930	2.0285	.5949
18	.1664	1.2560	.9706	.4982	2.0074	.6067
19	.1867	1.2882	.9719	.5037	1.9853	.6188
20	.2045	1.3145	.9706	.5096	1.9625	.6278
21	.2731	1.4011	.9735	.5258	1.9018	.6588
22	.2756	1.4028	.9718	.5271	1.8972	.6587
23	.3620	1.4874	.9751	.5437	1.8392	.6877
24	.4128	1.5311	.9774	.5524	1.8104	.7023
25	.4686	1.5720	.9790	.5610	1.7825	.7155
26	.5321	1.6273	.9799	.5738	1.7429	.7324
27	.5753	1.6569	.9792	.5814	1.7199	.7408
28	.6414	1.6977	.9796	.5915	1.6906	.7526
29	.6972	1.7376	.9811	.6009	1.6642	.7642
30	.7887	1.8063	.9818	.6187	1.6164	.7829
31	.8598	1.8578	.9824	.6324	1.5813	.7965
32	.9335	1.9114	.9843	.6463	1.5474	.8106
33	1.0046	1.9661	.9862	.6608	1.5132	.8246
34	1.0986	2.0324	.9878	.6795	1.4718	.8406
35	1.1748	2.0949	.9892	.6977	1.4334	.8551
36	1.2611	2.1591	.9907	.7169	1.3949	.8694
37	1.3551	2.2221	.9909	.7372	1.3564	.8823
38	1.4516	2.3059	.9928	.7639	1.3091	.8995
39	1.5354	2.3709	.9947	.7849	1.2741	.9124
40	1.6218	2.4410	.9961	.8087	1.2365	.9254
41	1.7005	2.5137	.9969	.8346	1.1982	.9381
42	1.7615	2.5514	.9967	.8489	1.1780	.9441
43	1.8707	2.6342	.9971	.8802	1.1361	.9572
44	1.9622	2.6995	.9999	.9033	1.1070	.9683
45	2.0409	2.7504	1.0011	.9226	1.0839	.9762
46	2.1323	2.8035	1.0018	.9436	1.0597	.9839
47	2.2441	2.8495	1.0017	.9628	1.0386	.9901
48	2.3482	2.8808	1.0012	.9764	1.0241	.9939
49	2.4625	2.9058	1.0006	.9877	1.0125	.9968
50	2.4651	2.9056	.9994	.9887	1.0114	.9962

NSWC TR 79-153

TABLE A-3 BOUNDARY LAYER PROFILE LISTING
RUN NO 802033 CONT.

N	Y (CM)	M	TT/TTE	D/DE	T/TE	U/UE
* 51	2.5794	2.9221	.9992	.9960	1.0040	.9982
** 52	2.7013	2.9332	1.0000	1.0000	1.0000	1.0000
53	2.8486	2.9419	.9996	1.0041	.9959	1.0009
54	2.9680	2.9471	.9991	1.0069	.9931	1.0013
55	3.0899	2.9481	.9974	1.0091	.9910	1.0006
56	3.2118	2.9440	.9967	1.0080	.9921	.9997
57	3.4150	2.9318	.9959	1.0035	.9965	.9978
58	3.6919	2.9176	.9956	.9977	1.0023	.9958
59	4.0526	2.9184	.9944	.9992	1.0008	.9953
60	4.3447	2.9210	.9916	1.0032	.9968	.9943
61	4.5479	2.9239	.9916	1.0044	.9956	.9946
62	4.7511	2.9254	.9916	1.0050	.9950	.9948
63	5.0254	2.9239	.9905	1.0056	.9945	.9941
64	5.4013	2.9187	.9898	1.0040	.9960	.9931
65	5.6706	2.9234	.9887	1.0071	.9929	.9931

NSWC TR 79-153

TABLE A-3 BOUNDARY LAYER PROFILE LISTING
RUN NO 802077

X = 1.981E+00 M	ME = 2.930E+00	DEL = 2.739E+00 CM
PO = 2.070E+05 N/M2	DE = 1.895E-01 KG/M3	DSTR = 1.037E+00 CM
TO = 3.175E+02 DEG.K	TE = 1.169E+02 DEG.K	TH = 1.988E-01 CM
PSW = 6.315E+03 N/M2	UE = 6.349E+02 M/S	THE = 3.489E-01 CM
TW = 2.906E+02 N/M2	RE = 1.484E+07 1/M	THH = 1.084E-02 CM
TAUW = 5.222E+01 N/M2	CF = 1.368E-03	RETH = 7.486E+04
K = 3.302E-02 CM	MDOT = 4.883E-02 KG/M2*5	

N	Y (CM)	M	TT/TTE	D/DE	T/TE	U/UE
1	0.0000	0.0000	.9153	.4021	2.4869	0.0000
2	.0064	.6955	.9177	.4399	2.2734	.3579
3	.0114	.7109	.9191	.4409	2.2679	.3654
4	.0165	.7309	.9202	.4427	2.2587	.3749
5	.0292	.8169	.9234	.4518	2.2135	.4148
6	.0521	.9230	.9270	.4647	2.1519	.4621
7	.0699	.9755	.9297	.4712	2.1221	.4850
8	.0902	1.0294	.9314	.4789	2.0881	.5077
9	.1130	1.0736	.9354	.4842	2.0654	.5266
10	.1359	1.1243	.9394	.4908	2.0373	.5477
11	.1638	1.1748	.9428	.4981	2.0075	.5681
12	.1918	1.2128	.9455	.5038	1.9849	.5832
13	.2502	1.2870	.9515	.5149	1.9420	.6121
14	.2807	1.3130	.9533	.5192	1.9260	.6219
15	.3315	1.3605	.9564	.5273	1.8965	.6394
16	.3543	1.3797	.9592	.5298	1.8875	.6469
17	.4229	1.4383	.9618	.5410	1.8483	.6674
18	.5017	1.5024	.9651	.5536	1.8065	.6892
19	.5626	1.5403	.9683	.5605	1.7842	.7022
20	.6464	1.6094	.9718	.5749	1.7394	.7244
21	.7303	1.6685	.9746	.5879	1.7009	.7427
22	.8115	1.7225	.9753	.6013	1.6631	.7581
23	.9792	1.8266	.9824	.6246	1.6009	.7888
24	1.0655	1.8888	.9845	.6406	1.5611	.8054
25	1.1570	1.9549	.9877	.6575	1.5210	.8228
26	1.3068	2.0699	.9933	.6881	1.4533	.8516
27	1.4211	2.1402	.9959	.7081	1.4122	.8680
28	1.4415	2.1623	.9951	.7157	1.3972	.8723
29	1.5253	2.2209	.9978	.7328	1.3647	.8855
30	1.6320	2.3109	1.0017	.7599	1.3160	.9048
31	1.7183	2.3830	1.0007	.7855	1.2730	.9177
32	1.8021	2.4538	1.0001	.8112	1.2328	.9299
33	1.8834	2.4973	1.0054	.8227	1.2155	.9397
34	1.9495	2.5437	1.0077	.8379	1.1935	.9484
35	2.0206	2.6020	1.0086	.8590	1.1641	.9581
36	2.0892	2.6545	1.0096	.8783	1.1385	.9667
37	2.1781	2.7107	1.0088	.9010	1.1098	.9746
38	2.2949	2.7744	1.0006	.9341	1.0706	.9797
39	2.3889	2.8262	1.0053	.9509	1.0516	.9891
40	2.5083	2.8695	1.0070	.9674	1.0337	.9957
41	2.6353	2.9046	1.0045	.9846	1.0156	.9990
* 42	2.7394	2.9191	1.0014	.9940	1.0061	.9993
** 43	2.8689	2.9300	1.0000	1.0000	1.0000	1.0000
44	3.2703	2.9425	.9980	1.0074	.9926	1.0006
45	3.4125	2.9384	.9984	1.0052	.9948	1.0002
46	3.6817	2.9309	.9979	1.0025	.9975	.9990

NSWC TR 79-153

TABLE A-3 BOUNDARY LAYER PROFILE LISTING
RUN NO 802078

X = 1.981E+00 M ME = 2.922E+00 DFI = 3.377E+00 CM
 PO = 1.040E+05 N/M2 DE = 9.556E-02 KG/M3 DSTR = 1.191E+00 CM
 TO = 3.194E+02 DEG.K TE = 1.180E+02 DEG.K TH = 2.273E-01 CM
 PSW = 3.230E+03 N/M2 UE = 6.362E+02 M/S THF = 3.942E-01 CM
 TW = 2.939E+02 N/M2 RE = 7.429E+06 1/M THH = 1.598E-02 CM
 TAUW = 1.830E+01 N/M2 CF = 9.470E-04 RETH = 4.285E+04
 K = 3.302E-02 CM MDOT = 4.883E-02 KG/M2*CS

N	Y (CM)	M	TT/TTE	D/DE	T/TE	U/UE
1	0.0000	0.0000	.9203	.4014	2.4916	0.0000
2	.0064	.5623	.9114	.4309	2.3208	.2932
3	.0064	.6016	.9201	.4305	2.3228	.3138
4	.0165	.6441	.9157	.4368	2.2893	.3335
5	.0216	.6778	.9147	.4409	2.2680	.3494
6	.0267	.7161	.9130	.4461	2.2418	.3670
7	.0267	.7474	.9154	.4486	2.2292	.3819
8	.0826	.9450	.9211	.4726	2.1158	.4704
9	.1511	1.0609	.9282	.4875	2.0513	.5201
10	.2121	1.1292	.9314	.4977	2.0093	.5478
11	.2629	1.1936	.9365	.5068	1.9731	.5738
12	.3391	1.2505	.9399	.5159	1.9385	.5959
13	.4026	1.2981	.9448	.5227	1.9132	.6145
14	.4661	1.3583	.9471	.5339	1.8730	.6362
15	.5321	1.3943	.9509	.5395	1.8537	.6497
16	.6007	1.4495	.9537	.5500	1.8181	.6689
17	.6845	1.5037	.9555	.5614	1.7813	.6869
18	.7861	1.5615	.9596	.5726	1.7464	.7063
19	.8852	1.6324	.9649	.5868	1.7041	.7294
20	.9817	1.6840	.9687	.5975	1.6735	.7456
21	1.0732	1.7491	.9729	.6119	1.6342	.7653
22	1.1519	1.7961	.9769	.6221	1.6075	.7794
23	1.2332	1.8614	.9789	.6388	1.5655	.7971
24	1.3145	1.9175	.9820	.6527	1.5321	.8123
25	1.4008	1.9746	.9858	.6668	1.4996	.8276
26	1.4643	2.0185	.9876	.6788	1.4733	.8385
27	1.5532	2.0823	.9908	.6961	1.4366	.8542
28	1.6345	2.1455	.9937	.7139	1.4007	.8691
29	1.7132	2.1998	.9985	.7279	1.3737	.8824
30	1.7767	2.2444	.9995	.7418	1.3480	.8919
31	1.8656	2.3140	1.0003	.7647	1.3077	.9057
32	1.9444	2.3662	1.0033	.7804	1.2814	.9168
33	2.0384	2.4356	1.0067	.8022	1.2465	.9307
34	2.1654	2.5407	1.0070	.8404	1.1900	.9486
35	2.2466	2.5918	1.0086	.8582	1.1652	.9576
36	2.3203	2.6405	1.0109	.8749	1.1430	.9662
37	2.3863	2.6805	1.0100	.8912	1.1221	.9718
38	2.4448	2.7220	1.0092	.9083	1.1010	.9775
39	2.5311	2.7861	1.0090	.9343	1.0703	.9865
40	2.6175	2.8075	1.0092	.9430	1.0605	.9895
41	2.6937	2.8445	1.0069	.9604	1.0412	.9934
42	2.7953	2.8738	1.0042	.9754	1.0253	.9959
43	2.9070	2.8958	1.0029	.9859	1.0143	.9981
* 44	3.3769	2.9296	.9997	1.0037	.9963	1.0008
** 45	3.9535	2.9218	1.0000	1.0000	1.0000	1.0000
46	4.5504	2.9222	1.0002	1.0000	1.0000	1.0002
47	5.0102	2.9102	1.0017	.9933	1.0068	.9994
48	5.4293	2.9003	1.0039	.9869	1.0133	.9992
49	5.7468	2.9075	1.0028	.9911	1.0090	.9996
50	6.2294	2.9203	1.0045	.9949	1.0051	1.0021

NSWC TR 79-153

TABLE A-3 BOUNDARY LAYER PROFILE LISTING
RUN NO 802079

X = 1.981E+00 M	ME = 2.887E+00	DEL = 3.722E+00 CM
PO = 5.164E+04 N/M2	DE = 4.873E-02 KG/M3	DSTR = 1.563E+00 CM
TO = 3.229E+02 DEG.K	TE = 1.211E+02 DEG.K	TH = 2.952E-01 CM
PSW = 1.677E+03 N/M2	UE = 6.368E+02 M/S	THE = 5.018E-01 CM
TW = 2.944E+02 N/M2	RE = 3.697E+06 1/M	THH = 2.809E-02 CM
TAUW = 5.124E+00 N/M2	CF = 5.190E-04	RETH = 2.769E+04
K = 3.302E-02 CM	MDOT = 4.883E-02 KG/M2*S	

N	Y (CM)	M	TT/TTE	D/DE	T/TE	U/UE
1	0.0000	0.0000	.9119	.4112	2.4320	0.0000
2	.0064	.3554	.9021	.4261	2.3466	.1886
3	.0114	.4152	.9079	.4272	2.3408	.2201
4	.0292	.5377	.9039	.4388	2.2789	.2812
5	.0445	.5957	.9042	.4441	2.2517	.3096
6	.0622	.6543	.9047	.4499	2.2226	.3379
7	.0749	.6970	.9054	.4543	2.2009	.3581
8	.0902	.7292	.9066	.4576	2.1855	.3734
9	.1029	.7600	.9073	.4610	2.1691	.3877
10	.1207	.7915	.9076	.4649	2.1512	.4021
11	.1384	.8103	.9095	.4664	2.1442	.4110
12	.1486	.8325	.9105	.4689	2.1327	.4211
13	.1664	.8576	.9119	.4716	2.1203	.4325
14	.1816	.8804	.9135	.4741	2.1093	.4429
15	.1969	.8894	.9143	.4750	2.1053	.4470
16	.2121	.9145	.9159	.4778	2.0928	.4582
17	.2273	.9225	.9169	.4785	2.0898	.4619
18	.2273	.9310	.9183	.4791	2.0872	.4659
19	.3010	1.0241	.9217	.4921	2.0319	.5056
20	.3950	1.0853	.9243	.5012	1.9950	.5310
21	.4991	1.1614	.9302	.5118	1.9538	.5623
22	.6007	1.2230	.9334	.5219	1.9162	.5864
23	.7176	1.2854	.9383	.5317	1.8809	.6106
24	.8573	1.3514	.9434	.5426	1.8429	.6354
25	.9944	1.4188	.9471	.5553	1.8009	.6595
26	1.1113	1.4818	.9525	.5665	1.7651	.6819
27	1.2383	1.5448	.9579	.5783	1.7294	.7036
28	1.3500	1.6202	.9627	.5940	1.6836	.7282
29	1.4415	1.6837	.9654	.6086	1.6431	.7475
30	1.5354	1.7278	.9687	.6182	1.6177	.7612
31	1.5964	1.7691	.9718	.6274	1.5940	.7737
32	1.6624	1.8100	.9747	.6367	1.5705	.7857
33	1.7463	1.8602	.9771	.6493	1.5402	.7996
34	1.8275	1.9194	.9812	.6637	1.5067	.8161
35	1.9139	1.9711	.9841	.6771	1.4770	.8298
36	2.0409	2.0465	.9883	.6972	1.4344	.8490
37	2.1044	2.1070	.9913	.7140	1.4005	.8637
38	2.1933	2.1644	.9945	.7303	1.3693	.8773
39	2.3000	2.2306	.9974	.7500	1.3333	.8922
40	2.3990	2.2915	1.0000	.7687	1.3008	.9052
41	2.5159	2.3730	1.0028	.7950	1.2578	.9219
42	2.6429	2.4481	1.0047	.8205	1.2187	.9361
43	2.7597	2.5292	1.0072	.8485	1.1785	.9510
44	2.9045	2.6127	1.0080	.8798	1.1367	.9648
45	3.0899	2.7225	1.0088	.9226	1.0839	.9818
46	3.2880	2.8012	1.0080	.9557	1.0463	.9925
47	3.4785	2.8542	1.0041	.9818	1.0185	.9977
* 48	3.7224	2.8838	1.0004	.9982	1.0018	.9998
** 49	4.0272	2.8871	1.0000	1.0000	1.0000	1.0000
50	4.3269	2.8832	.9996	.9988	1.0012	.9993

NSWC TR 79-153

TABLE A-3 BOUNDARY LAYER PROFILE LISTING
RUN NO R02034

X = 1.981E+00 M ME = 2.913E+00 DEL = 3.334E+00 CM
 PO = 2.070E+05 N/M2 DE = 1.881E-01 KG/M3 DSTR = 1.281E+00 CM
 TO = 3.246E+02 DEG.K TE = 1.204E+02 DEG.K TH = 2.442E-01 CM
 PSW = 6.513E+03 N/M2 UE = 6.405E+02 M/S THE = 4.219E-01 CM
 TW = 2.956E+02 N/M2 RE = 1.443E+07 1/M THH = 2.109E-02 CM
 TAUW = 2.739E+01 N/M2 CF = 7.105E-04 RETH = 8.945E+04
 K = 3.302E-02 CM MDOT = 1.465E-01 KG/M2*S

N	Y (CM)	M	TT/TTE	D/DE	T/TE	U/UE
1	0.0000	0.0000	.9107	.4072	2.4559	0.0000
2	.0064	.5388	.9240	.4246	2.3550	.2839
3	.0064	.5576	.9257	.4255	2.3502	.2935
4	.0165	.6072	.9274	.4293	2.3292	.3182
5	.0241	.6458	.9288	.4326	2.3118	.3371
6	.0241	.6457	.9293	.4323	2.3133	.3372
7	.0368	.7004	.9325	.4367	2.2899	.3639
8	.0445	.7321	.9336	.4398	2.2740	.3790
9	.0470	.7462	.9353	.4406	2.2695	.3859
10	.1181	.9551	.9436	.4647	2.1519	.4810
11	.2019	1.0643	.9481	.4797	2.0845	.5276
12	.2934	1.1530	.9524	.4929	2.0288	.5639
13	.4051	1.2544	.9583	.5087	1.9656	.6038
14	.5194	1.3208	.9616	.5202	1.9225	.6288
15	.6185	1.3760	.9640	.5304	1.8855	.6487
16	.6896	1.4171	.9657	.5382	1.8579	.6632
17	.7760	1.4717	.9668	.5497	1.8191	.6815
18	.8700	1.5327	.9687	.5627	1.7773	.7015
19	.9741	1.5898	.9710	.5749	1.7393	.7199
20	1.0732	1.6597	.9732	.5910	1.6922	.7413
21	1.2205	1.7496	.9767	.6121	1.6337	.7678
22	1.3246	1.8150	.9780	.6290	1.5899	.7858
23	1.4059	1.8750	.9797	.6447	1.5512	.8018
24	1.5659	1.9828	.9836	.6735	1.4849	.8295
25	1.6497	2.0473	.9846	.6923	1.4444	.8448
26	1.7310	2.1190	.9859	.7139	1.4008	.8610
27	1.8352	2.1934	.9884	.7362	1.3583	.8777
28	1.9291	2.2616	.9906	.7573	1.3205	.8922
29	1.9901	2.3116	.9921	.7732	1.2933	.9026
30	2.0688	2.3660	.9920	.7923	1.2621	.9126
31	2.1450	2.4297	.9933	.8141	1.2283	.9246
32	2.2441	2.5011	.9960	.8382	1.1931	.9380
33	2.3660	2.5852	.9983	.8680	1.1521	.9527
34	2.5819	2.7321	1.0021	.9225	1.0840	.9767
35	2.5972	2.7479	1.0025	.9285	1.0770	.9791
36	2.6962	2.7921	1.0030	.9462	1.0569	.9855
37	2.8258	2.8371	1.0029	.9650	1.0363	.9916
38	2.9451	2.8643	1.0036	.9758	1.0248	.9955
39	3.1179	2.8916	1.0036	.9874	1.0128	.9991
* 40	3.3338	2.9063	1.0022	.9951	1.0049	1.0003
** 41	3.4785	2.9126	1.0000	1.0000	1.0000	1.0000
42	3.6284	2.9162	.9983	1.0032	.9968	.9996
43	3.8240	2.9181	.9990	1.0034	.9966	1.0002
44	4.8578	2.9043	.9969	.9995	1.0005	.9974
45	5.8890	2.8943	.9932	.9989	1.0011	.9942
46	6.7729	2.9026	.9939	1.0017	.9983	.9957
47	7.5400	2.9019	.9939	1.0014	.9986	.9956
48	8.0023	2.9074	.9929	1.0049	.9951	.9958

NSWC TR 79-153

TABLE A-3 BOUNDARY LAYER PROFILE LISTING
RUN NO 820710

X = 1.981E+00 M	ME = 2.900E+00	DEL = 4.180E+00 CM
PO = 1.032E+05 N/M2	DE = 9.764E-02 KG/M3	DSTR = 1.936E+00 CM
TO = 3.203E+02 DEG.K	TE = 1.194E+02 DEG.K	TH = 3.415E-01 CM
PSW = 3.310E+03 N/M2	UE = 6.354E+02 M/S	THE = 5.648E-01 CM
TW = 2.930E+02 N/M2	RE = 7.490E+06 1/M	THH = 3.542E-02 CM
TAUW = 4.586E+00 N/M2	CF = 2.329E-04	RETH = 6.492E+04
K = 3.302E-02 CM	MDOT = 1.465E-01 KG/M2*S	

N	Y (CM)	M	TT/TTE	D/DE	T/TE	U/UE
1	0.0000	0.0000	.9146	.4076	2.4533	0.0000
2	.0064	.2904	.9014	.4205	2.3779	.1544
3	.0318	.3830	.8993	.4267	2.3435	.2022
4	.0546	.4512	.8991	.4315	2.3174	.2368
5	.1080	.5589	.9002	.4400	2.2728	.2905
6	.1283	.5941	.9001	.4434	2.2553	.3076
7	.1511	.6191	.9009	.4455	2.2446	.3198
8	.1715	.6456	.9013	.4481	2.2317	.3325
9	.1943	.6713	.9029	.4508	2.2184	.3478
10	.2146	.6937	.9028	.4527	2.2091	.3555
11	.2400	.7149	.9037	.4547	2.1993	.3655
12	.2629	.7410	.9049	.4572	2.1870	.3778
13	.2858	.7611	.9051	.4596	2.1757	.3871
14	.3112	.7806	.9052	.4620	2.1643	.3960
15	.3645	.8235	.9079	.4663	2.1445	.4158
16	.3823	.8355	.9086	.4676	2.1387	.4213
17	.4432	.8788	.9098	.4731	2.1139	.4405
18	.4966	.9179	.9123	.4775	2.0944	.4580
19	.5753	.9587	.9132	.4833	2.0693	.4755
20	.6515	1.0086	.9160	.4898	2.0416	.4969
21	.7938	1.0757	.9213	.4983	2.0069	.5254
22	.9792	1.1719	.9264	.5130	1.9495	.5641
23	1.1341	1.2522	.9327	.5250	1.9047	.5958
24	1.2916	1.3187	.9380	.5357	1.8668	.6212
25	1.5126	1.4344	.9466	.5559	1.7990	.6633
26	1.6472	1.5152	.9525	.5711	1.7509	.6913
27	1.7844	1.5887	.9580	.5856	1.7077	.7158
28	1.8910	1.6508	.9630	.5981	1.6719	.7359
29	2.0257	1.7317	.9682	.6159	1.6235	.7608
30	2.1171	1.8073	.9744	.6326	1.5809	.7835
31	2.2390	1.8872	.9804	.6511	1.5358	.8064
32	2.4473	2.0284	.9865	.6889	1.4517	.8426
33	2.6480	2.1533	.9938	.7230	1.3831	.8731
34	2.8791	2.3200	1.0035	.7714	1.2963	.9107
35	3.0645	2.4527	1.0056	.8167	1.2244	.9357
36	3.2042	2.5513	1.0100	.8496	1.1770	.9544
37	3.3515	2.6463	1.0115	.8848	1.1302	.9700
38	3.4938	2.7409	1.0092	.9245	1.0817	.9829
39	3.6106	2.7834	1.0090	.9420	1.0616	.9888
40	3.7173	2.8221	1.0071	.9598	1.0418	.9932
41	3.9307	2.8698	1.0054	.9816	1.0188	.9987
* 42	4.1796	2.8938	1.0009	.9963	1.0037	.9996
** 43	4.4082	2.9003	1.0000	1.0000	1.0000	1.0000
44	4.6368	2.9013	.9996	1.0008	.9992	.9999
45	4.8654	2.9006	1.0003	.9998	1.0002	1.0002
46	5.1321	2.8992	1.0007	.9988	1.0012	1.0002
47	5.4216	2.8981	1.0015	.9975	1.0025	1.0005
48	6.1481	2.8987	1.0026	.9967	1.0033	1.0011
49	6.4783	2.9000	1.0043	.9956	1.0045	1.0021
50	6.7755	2.9030	1.0042	.9970	1.0030	1.0024

NSWC TR 79-153

TABLE A-3 BOUNDARY LAYER PROFILE LISTING
RUN NO 802222

X = 1.981E+00 M	ME = 2.910E+00	DEL = 2.671E+00 CM
PO = 4.113E+05 N/M2	DE = 3.706E-01 KG/M3	USTR = 1.048E+00 CM
TU = 3.236E+02 DEG.K	TE = 1.202E+02 DEG.K	TH = 2.075E-01 CM
PSW = 1.264E+04 N/M2	UE = 6.394E+02 M/S	THE = 3.632E-01 CM
TW = 3.002E+02 N/M2	RE = 2.843E+07 1/M	THH = 2.261E-02 CM
TAUW = 1.904E+02 N/M2	CF = 2.515E-03	RETH = 1.497E+05
K = 1.245E-01 CM	MDOT = 0.	KG/M2*S

N	Y (CM)	M	TT/TTE	D/DE	T/TE	U/UE
1	0.0000	0.0000	.9277	.4002	2.4985	0.0000
2	.0064	.6786	.9415	.4307	2.3218	.3554
3	.0140	.6794	.9404	.4313	2.3186	.3555
4	.0165	.6911	.9402	.4326	2.3114	.3611
5	.0267	.7269	.9419	.4359	2.2942	.3784
6	.0343	.7450	.9419	.4380	2.2833	.3869
7	.0648	.8545	.9455	.4500	2.2220	.4378
8	.0902	.9319	.9488	.4593	2.1771	.4726
9	.1283	1.0152	.9506	.4711	2.1226	.5084
10	.1664	1.0940	.9534	.4827	2.0719	.5412
11	.2045	1.1532	.9556	.4919	2.0329	.5651
12	.2400	1.1967	.9572	.4990	2.0040	.5822
13	.3340	1.3277	.9609	.5227	1.9132	.6312
14	.3721	1.3512	.9612	.5274	1.8962	.6395
15	.4051	1.3793	.9634	.5321	1.8794	.6499
16	.4432	1.4162	.9647	.5393	1.8543	.6628
17	.4839	1.4442	.9652	.5452	1.8342	.6722
18	.4839	1.4425	.9639	.5455	1.8332	.6713
19	.5220	1.4762	.9658	.5520	1.8115	.6828
20	.5626	1.5116	.9671	.5594	1.7875	.6946
21	.6464	1.5674	.9685	.5718	1.7489	.7124
22	.6871	1.6021	.9691	.5798	1.7247	.7231
23	.7887	1.6776	.9695	.5986	1.6707	.7452
24	.8928	1.7494	.9726	.6155	1.6248	.7664
25	1.0020	1.8338	.9766	.6359	1.5725	.7903
26	1.1341	1.9301	.9792	.6617	1.5112	.8155
27	1.2611	2.0104	.9806	.6847	1.4604	.8350
28	1.4059	2.0984	.9821	.7110	1.4064	.8553
29	1.6066	2.2560	.9874	.7588	1.3176	.8901
30	1.7335	2.3646	.9898	.7946	1.2584	.9117
31	1.8809	2.4467	.9920	.8224	1.2159	.9272
32	2.0561	2.5939	.9958	.8747	1.1433	.9532
33	2.2187	2.7094	.9973	.9189	1.0883	.9714
34	2.3584	2.7890	.9991	.9498	1.0529	.9836
35	2.5667	2.8730	.9998	.9845	1.0158	.9952
* 36	2.6708	2.8978	1.0003	.9945	1.0055	.9987
** 37	2.7902	2.9096	1.0000	1.0000	1.0000	1.0000
38	3.1407	2.9123	.9995	1.0017	.9983	1.0001
39	3.2601	2.9102	.9976	1.0026	.9974	.9989
40	3.3922	2.9092	.9964	1.0034	.9966	.9982
41	3.5268	2.9081	.9958	1.0035	.9965	.9977
42	3.6741	2.9031	.9957	1.0015	.9985	.9970
43	3.8011	2.9047	.9957	1.0021	.9979	.9972
44	4.0500	2.9057	.9940	1.0044	.9957	.9965
45	4.2634	2.9095	.9941	1.0059	.9942	.9970
46	4.4793	2.9135	.9930	1.0087	.9913	.9970
47	5.2210	2.9201	.9920	1.0127	.9875	.9973
48	5.2210	2.9159	.9919	1.0109	.9892	.9967
49	5.9804	2.9106	.9889	1.0117	.9884	.9945
50	6.2903	2.9016	.9887	1.0080	.9921	.9933

NSWC TR 79-153

TABLE A-3 BOUNDARY LAYER PROFILE LISTING
RUN NO 802223

X = 1.981E+00 M ME = 2.883E+00 DEL = 2.656E+00 CM
 PU = 3.097E+05 N/M2 DE = 2.832E-01 KG/M3 DSTR = 1.037E+00 CM
 TO = 3.184E+02 DEG.K TE = 1.196E+02 DEG.K TH = 2.060E-01 CM
 PSW = 9.635E+03 N/M2 UE = 6.320E+02 M/S THE = 3.599E-01 CM
 TW = 2.958E+02 N/M2 RE = 2.158E+07 1/M THH = 1.965E-02 CM
 TAUW = 1.392E+02 N/M2 CF = 2.463E-03 RETH = 1.128E+05
 K = 1.245E-01 CM MDOT = 0. KG/M2*S

N	Y (CM)	M	TT/TTE	D/DE	T/TE	U/UE
1	0.0000	0.0000	.9291	.4042	2.4738	0.0000
2	.0064	.6663	.9373	.4363	2.2922	.3499
3	.0114	.6721	.9352	.4379	2.2838	.3523
4	.0216	.6989	.9364	.4403	2.2714	.3653
5	.0292	.7296	.9388	.4426	2.2592	.3804
6	.0343	.7535	.9400	.4449	2.2476	.3918
7	.0419	.7723	.9393	.4475	2.2346	.4004
8	.0470	.7987	.9400	.4505	2.2197	.4127
9	.0546	.8217	.9401	.4535	2.2052	.4232
10	.0546	.8230	.9406	.4534	2.2058	.4239
11	.0800	.9007	.9422	.4633	2.1985	.4590
12	.1029	.9623	.9445	.4713	2.1219	.4862
13	.1257	1.0114	.9454	.4785	2.0897	.5071
14	.1537	1.0670	.9465	.4872	2.0527	.5302
15	.1791	1.1121	.9478	.4943	2.0232	.5487
16	.2121	1.1574	.9492	.5017	1.9933	.5667
17	.2375	1.2030	.9500	.5098	1.9616	.5844
18	.2629	1.2278	.9502	.5144	1.9438	.5937
19	.2883	1.2619	.9529	.5196	1.9244	.6071
20	.3061	1.2849	.9536	.5239	1.9089	.6157
21	.3289	1.3009	.9536	.5272	1.8970	.6214
22	.3543	1.3287	.9545	.5324	1.8782	.6316
23	.3721	1.3474	.9545	.5364	1.8644	.6381
24	.3975	1.3729	.9547	.5417	1.8461	.6470
25	.4229	1.3955	.9549	.5465	1.8298	.6547
26	.4509	1.4121	.9548	.5502	1.8175	.6603
27	.4712	1.4324	.9554	.5544	1.8038	.6672
28	.4966	1.4490	.9560	.5578	1.7926	.6729
29	.5499	1.4932	.9590	.5662	1.7660	.6882
30	.5804	1.5171	.9621	.5701	1.7541	.6969
31	.6058	1.5358	.9644	.5732	1.7447	.7036
32	.6312	1.5527	.9660	.5762	1.7354	.7094
33	.6642	1.5758	.9679	.5807	1.7220	.7172
34	.6922	1.5932	.9696	.5840	1.7124	.7231
35	.7252	1.6141	.9720	.5877	1.7014	.7302
36	.7607	1.6471	.9759	.5937	1.6845	.7414
37	.7988	1.6709	.9790	.5978	1.6727	.7495
38	.8446	1.6971	.9816	.6030	1.6583	.7580
39	.8674	1.7150	.9821	.6074	1.6465	.7632
40	.9055	1.7399	.9817	.6142	1.6281	.7700
41	.9309	1.7603	.9805	.6204	1.6119	.7751
42	.9538	1.7767	.9810	.6245	1.6012	.7798
43	.9817	1.7908	.9826	.6274	1.5940	.7842
44	1.0528	1.8463	.9813	.6436	1.5537	.7982
45	1.1443	1.9115	.9826	.6615	1.5117	.8151
46	1.2306	1.9657	.9848	.6761	1.4790	.8291
47	1.3322	2.0424	.9863	.6985	1.4317	.8476
48	1.4338	2.1200	.9884	.7215	1.3860	.8656
49	1.5354	2.1847	.9907	.7410	1.3496	.8803
50	1.6345	2.2629	.9922	.7662	1.3051	.8966

NSWC TR 79-153

TABLE A-3 BOUNDARY LAYER PROFILE LISTING
RUN NO 802223 CONT.

N	Y (CM)	M	TT/TTE	D/DE	T/TE	U/UE
51	1.7234	2.3348	.9928	.7907	1.2646	.9106
52	1.8148	2.4033	.9950	.8135	1.2293	.9242
53	1.9418	2.5076	.9962	.8511	1.1750	.9427
54	2.0790	2.6044	.9978	.8870	1.1274	.9591
55	2.1704	2.6700	.9987	.9123	1.0962	.9695
56	2.2492	2.7169	.9997	.9303	1.0749	.9769
57	2.3863	2.7943	1.0006	.9614	1.0401	.9884
58	2.4829	2.8344	1.0002	.9788	1.0217	.9937
59	2.5743	2.8633	1.0002	.9912	1.0089	.9975
* 60	2.6556	2.8833	1.0000	1.0000	1.0000	1.0000
61	2.7648	2.8942	1.0002	1.0045	.9955	1.0015
62	2.8740	2.8986	1.0009	1.0058	.9943	1.0024
63	2.9807	2.9000	.9991	1.0082	.9919	1.0017
64	3.1179	2.8996	1.0009	1.0062	.9939	1.0026
65	3.4938	2.8937	1.0044	1.0001	.9999	1.0036
66	3.7503	2.8947	1.0056	.9994	1.0006	1.0043
67	4.0729	2.8952	1.0056	.9996	1.0004	1.0044
68	4.3752	2.8994	1.0051	1.0019	.9981	1.0046
69	4.5250	2.9021	1.0058	1.0024	.9976	1.0053
70	4.7079	2.9037	1.0058	1.0031	.9969	1.0055
71	4.9975	2.9046	1.0052	1.0040	.9960	1.0054
72	5.2794	2.9017	1.0033	1.0047	.9954	1.0041
73	5.5258	2.9020	1.0022	1.0060	.9941	1.0035
74	5.8890	2.8961	1.0014	1.0041	.9959	1.0024
75	6.3157	2.8907	1.0007	1.0025	.9975	1.0013
76	6.6485	2.8924	.9996	1.0044	.9956	1.0010
77	7.0803	2.8884	.9989	1.0033	.9967	1.0001
78	7.5070	2.8889	.9989	1.0035	.9965	1.0002
79	7.9108	2.8902	.9984	1.0047	.9954	1.0001
80	8.3782	2.8832	.9982	1.0018	.9982	.9991
81	8.6170	2.8717	.9974	.9976	1.0024	.9972

NSWC TR 79-153

TABLE A-3 BOUNDARY LAYER PROFILE LISTING
RUN NO R02234

X = 1.981E+00 M	ME = 2.912E+00	DEL = 3.044E+00 CM
PO = 2.010E+05 N/M2	DE = 1.811E-01 KG/M3	DSTR = 1.145E+00 CM
TO = 3.219E+02 DEG.K	TE = 1.194E+02 DEG.K	TH = 2.138E-01 CM
PSW = 6.185E+03 N/M2	UE = 6.379E+02 M/S	THF = 3.709E-01 CM
TW = 2.974E+02 N/M2	RE = 1.395E+07 1/M	THH = 8.962E-03 CM
TAUW = 8.790E+01 N/M2	CF = 2.387E-03	RETH = 7.570E+04
K = 1.245E-01 CM	MDOT = 0.	KG/M2*S

N	Y (CM)	M	TT/TE	D/DE	T/TE	U/UE
1	0.0000	0.0000	.9238	.4015	2.4906	0.0000
2	.0064	.5891	.9261	.4283	2.3348	.3091
3	.0114	.6163	.9269	.4306	2.3226	.3225
4	.0216	.6451	.9275	.4332	2.3086	.3366
5	.0267	.6674	.9280	.4353	2.2973	.3474
6	.0470	.7462	.9313	.4426	2.2591	.3851
7	.0648	.8002	.9338	.4481	2.2317	.4105
8	.0800	.8452	.9366	.4526	2.2095	.4314
9	.0978	.8784	.9383	.4563	2.1916	.4466
10	.1181	.9225	.9406	.4614	2.1671	.4663
11	.1410	.9773	.9442	.4679	2.1373	.4906
12	.1816	1.0409	.9470	.4765	2.0985	.5178
13	.2045	1.0820	.9493	.4822	2.0738	.5351
14	.2527	1.1394	.9527	.4904	2.0390	.5587
15	.2858	1.1740	.9549	.4955	2.0182	.5727
16	.2858	1.1760	.9550	.4958	2.0168	.5735
17	.3213	1.2125	.9572	.5014	1.9943	.5880
18	.3442	1.2328	.9573	.5052	1.9793	.5956
19	.3594	1.2490	.9579	.5081	1.9683	.6017
20	.3620	1.2592	.9577	.5101	1.9604	.6054
21	.4382	1.3297	.9641	.5208	1.9202	.6327
22	.5372	1.4059	.9674	.5350	1.8692	.6601
23	.6363	1.4835	.9703	.5505	1.8164	.6866
24	.7404	1.5574	.9737	.5657	1.7676	.7110
25	.8623	1.6406	.9774	.5838	1.7129	.7374
26	.9817	1.7202	.9812	.6017	1.6619	.7615
27	1.1036	1.8071	.9850	.6225	1.6063	.7865
28	1.2916	1.9435	.9902	.6575	1.5209	.8230
29	1.3983	2.0093	.9928	.6753	1.4809	.8397
30	1.5126	2.1008	.9975	.7001	1.4284	.8622
31	1.6421	2.1874	1.0016	.7247	1.3798	.8823
32	1.7767	2.3018	1.0029	.7618	1.3127	.9056
33	1.9012	2.3867	1.0046	.7898	1.2661	.9222
34	2.0409	2.5035	1.0072	.8299	1.2049	.9437
35	2.1628	2.5940	1.0070	.8640	1.1574	.9583
36	2.3076	2.7125	1.0068	.9106	1.0982	.9761
37	2.4752	2.7914	1.0051	.9441	1.0592	.9865
38	2.6784	2.8650	1.0037	.9761	1.0244	.9958
39	2.8308	2.8963	1.0023	.9909	1.0092	.9991
* 40	3.0442	2.9103	1.0010	.9983	1.0017	1.0003
** 41	3.2576	2.9121	1.0000	1.0000	1.0000	1.0000
42	3.7224	2.9109	1.0000	.9995	1.0005	.9998
43	4.3167	2.9164	.9998	1.0021	.9979	1.0005
44	4.8171	2.9270	1.0017	1.0047	.9953	1.0027
45	5.2413	2.9214	1.0016	1.0024	.9976	1.0020

NSWC TR 79-153

TABLE A-3 BOUNDARY LAYER PROFILE LISTING
RUN NO 802235

X = 1.981E+00 M	ME = 2.890E+00	DFL = 2.971E+00 CM
PO = 1.029E+05 N/M2	DE = 9.477E-02 KG/M3	DSTR = 1.205E+00 CM
TO = 3.185E+02 DFG.K	TE = 1.193E+02 DEG.K	TH = 2.286E-01 CM
PSW = 3.226E+03 N/M2	UE = 6.327E+02 M/S	THE = 3.938E-01 CM
TW = 2.953E+02 N/M2	RE = 7.249E+06 1/M	THH = 1.735E-02 CM
TAUW = 4.307E+01 N/M2	CF = 2.272E-03	RETH = 4.206E+04
K = 1.245E-01 CM	MDOT = 0.	KG/M2* ^c

N	Y (CM)	M	TT/TTE	D/DE	T/TE	U/UE
1	0.0000	0.0000	.9269	.4039	2.4756	0.0000
2	.0064	.5200	.9243	.4270	2.3419	.2753
3	.0089	.5239	.9270	.4261	2.3471	.2777
4	.0089	.5298	.9282	.4260	2.3473	.2808
5	.0114	.5427	.9285	.4270	2.3419	.2873
6	.0140	.5642	.9284	.4290	2.3311	.2980
7	.0191	.5821	.9284	.4306	2.3221	.3069
8	.0216	.5956	.9282	.4320	2.3147	.3135
9	.0267	.6116	.9290	.4332	2.3084	.3215
10	.0292	.6257	.9305	.4339	2.3048	.3287
11	.0343	.6428	.9314	.4352	2.2976	.3371
12	.0419	.6593	.9319	.4367	2.2897	.3452
13	.0470	.6766	.9324	.4383	2.2813	.3536
14	.0495	.6872	.9327	.4393	2.2762	.3587
15	.0546	.7028	.9323	.4413	2.2662	.3660
16	.0622	.7212	.9338	.4427	2.2589	.3750
17	.0648	.7285	.9332	.4438	2.2533	.3783
18	.0673	.7349	.9317	.4453	2.2457	.3810
19	.0724	.7475	.9303	.4475	2.2348	.3866
20	.0749	.7588	.9290	.4494	2.2251	.3916
21	.0800	.7673	.9283	.4509	2.2180	.3954
22	.0851	.7770	.9275	.4524	2.2103	.3997
23	.0876	.7884	.9253	.4549	2.1981	.4044
24	.1003	.8240	.9273	.4586	2.1804	.4210
25	.1156	.8550	.9303	.4613	2.1678	.4356
26	.1283	.8851	.9308	.4653	2.1492	.4489
27	.1435	.9091	.9323	.4680	2.1368	.4598
28	.1562	.9335	.9339	.4708	2.1239	.4707
29	.1740	.9623	.9355	.4744	2.1081	.4834
30	.1867	.9809	.9363	.4769	2.0971	.4915
31	.1994	.9992	.9367	.4795	2.0853	.4992
32	.2121	1.0213	.9384	.4822	2.0737	.5088
33	.2324	1.0421	.9396	.4851	2.0616	.5177
34	.2477	1.0588	.9402	.4875	2.0512	.5247
35	.2604	1.0763	.9410	.4901	2.0403	.5319
36	.2858	1.1050	.9430	.4940	2.0242	.5439
37	.3010	1.1139	.9436	.4953	2.0191	.5476
38	.3137	1.1339	.9447	.4983	2.0070	.5558
39	.3239	1.1424	.9452	.4995	2.0019	.5592
40	.3366	1.1577	.9461	.5019	1.9926	.5654
41	.3518	1.1706	.9465	.5040	1.9841	.5705
42	.3696	1.1848	.9484	.5056	1.9777	.5765
43	.3874	1.1990	.9488	.5081	1.9681	.5820
44	.4051	1.2143	.9506	.5100	1.9606	.5883
45	.4280	1.2368	.9518	.5138	1.9465	.5970
46	.4382	1.2487	.9531	.5154	1.9403	.6018
47	.5372	1.3219	.9562	.5284	1.8925	.6292
48	.6210	1.4007	.9607	.5427	1.8427	.6578
49	.7049	1.4623	.9640	.5545	1.8034	.6794
50	.8217	1.5370	.9668	.5702	1.7537	.7042

NSWC TR 79-153

TABLE A-3 BOUNDARY LAYER PROFILE LISTING
RUN NO 802235 CONT.

N	Y (CM)	M	TT/TTE	D/DE	T/TE	U/UE
51	.9385	1.6208	.9709	.5883	1.6999	.7311
52	1.0427	1.6911	.9759	.6031	1.6581	.7534
53	1.1570	1.7642	.9795	.6202	1.6123	.7750
54	1.2687	1.8359	.9833	.6374	1.5688	.7956
55	1.3424	1.8938	.9856	.6523	1.5329	.8112
56	1.4186	1.9449	.9869	.6664	1.5006	.8243
57	1.5075	2.0176	.9887	.6870	1.4556	.8422
58	1.5964	2.0777	.9913	.7039	1.4208	.8568
59	1.6929	2.1476	.9941	.7241	1.3811	.8732
60	1.7894	2.2175	.9976	.7445	1.3433	.8892
61	1.9012	2.3159	.9992	.7767	1.2875	.9092
62	2.0003	2.4115	1.0001	.8098	1.2349	.9271
63	2.0714	2.4540	1.0004	.8251	1.2120	.9347
64	2.1679	2.5146	1.0022	.8461	1.1819	.9458
65	2.2543	2.5910	1.0038	.8738	1.1444	.9590
66	2.3584	2.6549	1.0044	.8983	1.1132	.9692
67	2.4575	2.7118	1.0039	.9215	1.0852	.9774
68	2.5616	2.7707	1.0036	.9459	1.0572	.9856
69	2.6708	2.8161	1.0026	.9658	1.0354	.9914
70	2.8156	2.8596	1.0015	.9853	1.0149	.9967
* 71	2.9705	2.8829	1.0013	.9955	1.0045	.9997
** 72	3.0823	2.8903	1.0000	1.0000	1.0000	1.0000
73	3.2423	2.8937	1.0002	1.0013	.9987	1.0005
74	3.3896	2.8928	.9992	1.0019	.9981	.9999
75	3.5547	2.8931	.9998	1.0014	.9986	1.0003
76	3.7503	2.8931	.9994	1.0018	.9982	1.0001
77	3.9764	2.8925	1.0008	1.0001	.9999	1.0007
78	4.1796	2.8940	1.0007	1.0009	.9991	1.0008
79	4.3879	2.8953	1.0003	1.0018	.9982	1.0008
80	4.6012	2.8980	1.0009	1.0024	.9976	1.0015
81	4.8374	2.9043	1.0015	1.0046	.9954	1.0025
82	5.0965	2.9061	1.0016	1.0053	.9948	1.0026
83	5.2616	2.9051	1.0022	1.0042	.9958	1.0030
84	5.6248	2.8980	1.0023	1.0010	.9990	1.0021
85	5.8839	2.8946	1.0025	.9994	1.0006	1.0018

NSWC TR 79-153

TABLE A-3 BOUNDARY LAYER PROFILE LISTING
KUN NO 802236

X = 1.981E+00 M ME = 2.865E+00 DEL = 3.095E+00 CM
 PU = 5.281E+04 N/M2 DE = 4.915E-02 KG/M3 DSTP = 1.249E+00 CM
 TO = 3.182E+02 DEG.K TE = 1.204E+02 DEG.K TH = 2.419E-01 CM
 PSW = 1.687E+03 N/M2 UE = 6.303E+02 M/S THE = 4.171E-01 CM
 TW = 2.948E+02 N/M2 RE = 3.710E+06 1/M THH = 1.898E-02 CM
 TAUW = 2.097E+01 N/M2 CF = 2.149E-03 RETH = 2.278E+04
 K = 1.245E-01 CM MDOT = 0. KG/M2*S

N	Y (CM)	M	TT/TTE	D/DE	T/TE	U/UE
1	0.0000	0.0000	.9265	.4086	2.4476	0.0000
2	.0064	.4987	.9212	.4313	2.3185	.2650
3	.0114	.5304	.9231	.4331	2.3089	.2813
4	.0165	.5683	.9227	.4367	2.2898	.3002
5	.0241	.6069	.9227	.4404	2.2704	.3192
6	.0318	.6290	.9234	.4424	2.2606	.3301
7	.0343	.6521	.9251	.4439	2.2525	.3416
8	.0419	.6786	.9271	.4459	2.2427	.3547
9	.0495	.7037	.9274	.4486	2.2292	.3667
10	.0521	.7163	.9281	.4497	2.2237	.3728
11	.0724	.7712	.9299	.4555	2.1955	.3988
12	.0826	.8034	.9313	.4589	2.1792	.4139
13	.1054	.8572	.9338	.4649	2.1508	.4388
14	.1207	.8805	.9340	.4681	2.1362	.4492
15	.1156	.8808	.9324	.4689	2.1325	.4489
16	.1486	.9355	.9350	.4757	2.1023	.4734
17	.1664	.9621	.9358	.4794	2.0861	.4850
18	.1918	1.0017	.9357	.4857	2.0588	.5016
19	.2121	1.0287	.9370	.4895	2.0430	.5132
20	.2299	1.0523	.9377	.4931	2.0281	.5231
21	.2883	1.1152	.9403	.5027	1.9893	.5490
22	.3137	1.1371	.9404	.5066	1.9740	.5576
23	.3391	1.1638	.9416	.5109	1.9573	.5683
24	.3924	1.2096	.9441	.5183	1.9296	.5864
25	.4255	1.2378	.9447	.5235	1.9103	.5971
26	.4610	1.2617	.9457	.5277	1.8950	.6062
27	.4788	1.2745	.9462	.5300	1.8867	.6110
28	.5017	1.2886	.9476	.5321	1.8793	.6165
29	.5169	1.3044	.9475	.5354	1.8677	.6222
30	.5372	1.3232	.9479	.5391	1.8549	.6290
31	.6058	1.3690	.9519	.5467	1.8291	.6462
32	.7023	1.4438	.9549	.5617	1.7804	.6724
33	.8369	1.5226	.9625	.5756	1.7373	.7004
34	.9741	1.6092	.9677	.5937	1.6842	.7289
35	1.2357	1.7810	.9768	.6333	1.5790	.7811
36	1.4262	1.9156	.9840	.6670	1.4993	.8186
37	1.5050	1.9627	.9878	.6784	1.4741	.8317
38	1.5989	2.0194	.9906	.6938	1.4414	.8462
39	1.5989	2.0293	.9914	.6963	1.4362	.8488
40	1.6701	2.0760	.9921	.7104	1.4076	.8596
41	1.7691	2.1399	.9944	.7292	1.3713	.8746
42	1.8809	2.2405	.9986	.7597	1.3164	.8972
43	2.0130	2.3091	1.0003	.7819	1.2789	.9114
44	2.1273	2.4004	1.0026	.8126	1.2306	.9294
45	2.2619	2.4886	1.0050	.8431	1.1861	.9459
46	2.4067	2.5795	1.0053	.8776	1.1395	.9610
47	2.5235	2.6510	1.0065	.9047	1.1054	.9728
48	2.6632	2.7278	1.0053	.9369	1.0674	.9836
49	2.8080	2.7924	1.0039	.9651	1.0362	.9921
50	2.9375	2.8302	1.0024	.9826	1.0177	.9965

NSWC TR 79-153

TABLE A-3 BOUNDARY LAYER PROFILE LISTING
RUN NO 802236 CONT.

N	Y (CM)	M	TT/TTE	D/De	T/TE	U/UE
* 51	3.0950	2.8542	1.0020	.9932	1.0068	.9996
** 52	3.2626	2.8652	1.0000	1.0000	1.0000	1.0000
53	3.4150	2.8684	.9987	1.0026	.9974	.9998
54	3.6513	2.8694	.9998	1.0020	.9980	1.0004
55	3.8824	2.8720	.9988	1.0042	.9958	1.0003
56	4.1491	2.8723	.9990	1.0041	.9959	1.0004
57	4.4666	2.8745	.9987	1.0054	.9946	1.0006
58	4.7739	2.8797	.9993	1.0070	.9931	1.0016
59	5.2108	2.8832	.9998	1.0080	.9921	1.0023
60	5.6020	2.8809	.9997	1.0071	.9929	1.0019
61	6.0744	2.8690	.9999	1.0017	.9983	1.0005
62	6.4427	2.8590	.9999	.9974	1.0026	.9991
63	6.8085	2.8594	.9998	.9977	1.0023	.9991

NSWC TR 79-153

TABLE A-3 BOUNDARY LAYER PROFILE LISTING
RUN NO 802224

X = 1.981E+00 M	ME = 2.914E+00	DEL = 2.757E+00 CM
PO = 4.129E+05 N/M2	DE = 3.596E-01 KG/M3	USTR = 1.066E+00 CM
TO = 3.345E+02 DEG.K	TE = 1.240E+02 DEG.K	TH = 2.059E-01 CM
PSW = 1.269E+04 N/M2	UE = 6.504E+02 M/S	THE = 3.602E-01 CM
TW = 3.099E+02 N/M2	RE = 2.723E+07 1/M	THH = 1.635E-02 CM
TAUW = 1.835E+02 N/M2	CF = 2.415E-03	KETH = 1.423E+05
K = 1.245E-01 CM	MDOT = 1.465E-02 KG/M2*S	

N	Y (CM)	M	TT/TTE	D/DE	T/TE	U/UE
1	0.0000	0.0000	.9265	.4000	2.5000	0.0000
2	.0064	.6786	.9432	.4291	2.3305	.3555
3	.0165	.6747	.9426	.4290	2.3311	.3535
4	.0318	.7216	.9431	.4339	2.3048	.3759
5	.1029	.9529	.9501	.4609	2.1698	.4817
6	.1816	1.1106	.9558	.4834	2.0689	.5482
7	.2705	1.2454	.9601	.5057	1.9773	.6010
8	.5372	1.4923	.9694	.5526	1.8098	.6889
9	.7404	1.6446	.9748	.5859	1.7069	.7373
10	1.0071	1.8156	.9805	.6271	1.5946	.7868
11	1.1951	1.9465	.9846	.6616	1.5115	.8212
12	1.2891	2.0086	.9856	.6794	1.4719	.8362
13	1.4034	2.0838	.9875	.7012	1.4261	.8540
14	1.5202	2.1732	.9893	.7285	1.3727	.8738
15	1.6599	2.3115	.9930	.7720	1.2953	.9028
16	1.8174	2.3975	.9943	.8012	1.2482	.9192
17	2.0460	2.5942	.9986	.8707	1.1486	.9541
18	2.2695	2.7197	1.0012	.9177	1.0896	.9742
19	2.4016	2.7980	1.0025	.9485	1.0543	.9859
20	2.5184	2.8469	1.0031	.9683	1.0327	.9928
21	2.6276	2.8815	1.0027	.9833	1.0169	.9972
* 22	2.7572	2.9017	1.0020	.9927	1.0074	.9994
23	2.8994	2.9124	1.0005	.9987	1.0013	1.0001
** 24	3.0467	2.9141	1.0000	1.0000	1.0000	1.0000
25	3.1941	2.9116	.9982	1.0007	.9993	.9988
26	3.3414	2.9104	.9971	1.0014	.9986	.9981
27	3.6538	2.9071	.9953	1.0017	.9983	.9968
28	3.8570	2.9060	.9953	1.0012	.9988	.9966
29	3.9992	2.9063	.9941	1.0025	.9975	.9961
30	4.1415	2.9071	.9930	1.0040	.9960	.9956
31	4.4742	2.9135	.9909	1.0089	.9912	.9954
32	4.8146	2.9205	.9888	1.0141	.9861	.9952

NSWC TR 79-153

TABLE A-3 BOUNDARY LAYER PROFILE LISTING
RUN NO 802237

X = 1.981E+00 M ME = 2.904E+00 DEL = 2.866E+00 CM
 PO = 2.068E+05 N/M2 DE = 1.884E-01 KG/M3 DSTR = 1.176E+00 CM
 TO = 3.187E+02 DFG.K TE = 1.186E+02 DFG.K TH = 2.218E-01 CM
 PSW = 6.378E+03 N/M2 UE = 6.340E+02 M/S THE = 3.840E-01 CM
 TW = 2.964E+02 N/M2 RE = 1.452E+07 1/M THH = 1.409E-02 CM
 TAUW = 8.619E+01 N/M2 CF = 2.278E-03 PETH = 8.173E+04
 K = 1.245E-01 CM MDOT = 1.465E-02 KG/M2*5

N	Y (CM)	M	TT/TTE	D/DE	T/TE	U/UE
1	0.0000	0.0000	.9300	.4002	2.4987	0.0000
2	.0064	.5467	.9276	.4252	2.3518	.2887
3	.0140	.5784	.9303	.4268	2.3428	.3048
4	.0292	.6386	.9285	.4335	2.3067	.3339
5	.0445	.6978	.9302	.4391	2.2774	.3626
6	.0622	.7496	.9318	.4443	2.2508	.3872
7	.0749	.7882	.9328	.4486	2.2292	.4052
8	.0953	.8427	.9349	.4546	2.1996	.4303
9	.1130	.8795	.9362	.4590	2.1786	.4470
10	.1283	.9124	.9381	.4628	2.1608	.4618
11	.1461	.9487	.9395	.4674	2.1393	.4778
12	.1638	.9790	.9420	.4708	2.1240	.4913
13	.1791	1.0050	.9447	.4735	2.1118	.5029
14	.1994	1.0385	.9466	.4780	2.0920	.5172
15	.2121	1.0589	.9480	.4806	2.0807	.5259
16	.2223	1.0743	.9493	.4825	2.0723	.5325
17	.2223	1.0741	.9499	.4822	2.0738	.5326
18	.3162	1.1942	.9562	.5003	1.9989	.5814
19	.4026	1.2770	.9599	.5142	1.9448	.6132
20	.5093	1.3628	.9635	.5297	1.8878	.6447
21	.6185	1.4357	.9674	.5433	1.8406	.6707
22	.7404	1.5238	.9709	.5614	1.7814	.7003
23	.8725	1.6141	.9767	.5796	1.7254	.7300
24	.9995	1.6933	.9793	.5980	1.6722	.7540
25	1.1087	1.7709	.9831	.6160	1.6233	.7769
26	1.2256	1.8589	.9860	.6383	1.5666	.8012
27	1.3475	1.9430	.9882	.6610	1.5129	.8229
28	1.4694	2.0239	.9908	.6834	1.4633	.8430
29	1.5939	2.1126	.9941	.7086	1.4113	.8642
30	1.7056	2.1983	.9957	.7350	1.3605	.8829
31	1.8047	2.2709	.9973	.7581	1.3192	.8981
32	1.9114	2.3516	1.0005	.7834	1.2765	.9148
33	2.0460	2.4500	1.0023	.8171	1.2239	.9333
34	2.0536	2.4632	1.0012	.8228	1.2154	.9350
35	2.1984	2.5807	1.0032	.8652	1.1558	.9553
36	2.3000	2.6469	1.0043	.8898	1.1238	.9662
37	2.4041	2.7215	1.0048	.9190	1.0881	.9775
38	2.5260	2.7902	1.0039	.9480	1.0549	.9868
39	2.6302	2.8344	1.0018	.9684	1.0326	.9918
40	2.7521	2.8718	1.0010	.9851	1.0152	.9963
* 41	2.8664	2.8914	1.0012	.9933	1.0067	.9989
** 42	3.0137	2.9042	1.0000	1.0000	1.0000	1.0000
43	3.1585	2.9097	.9995	1.0020	.9971	1.0005
44	3.3211	2.9105	.9990	1.0037	.9963	1.0003
45	3.5192	2.9091	.9993	1.0028	.9972	1.0003
46	3.7021	2.9092	.9990	1.0032	.9968	1.0001
47	3.9002	2.9106	.9995	1.0032	.9968	1.0006
48	4.0932	2.9123	.9999	1.0036	.9964	1.0010
49	4.3142	2.9140	1.0003	1.0039	.9961	1.0014
50	4.5250	2.9192	.9995	1.0070	.9931	1.0017

NSWC TR 79-153

TABLE A-3 BOUNDARY LAYER PROFILE LISTING
RUN NO 802238

X = 1.981E+00 M ME = 2.888E+00 DEL = 3.359E+00 CM
 PO = 1.034E+05 N/M2 DE = 9.652E-02 KG/M3 DSTP = 1.276E+00 CM
 TO = 3.162E+02 DEG.K TE = 1.185E+02 DEG.K TH = 2.408E-01 CM
 PSW = 3.254E+03 N/M2 UE = 6.303E+02 M/S THE = 4.134E-01 CM
 TW = 2.920E+02 N/M2 RE = 7.399E+06 1/M THH = 1.753E-02 CM
 TAUW = 3.930E+01 N/M2 CF = 2.052E-03 RETH = 4.522E+04
 K = 1.245E-01 CM MDOT = 1.465E-02 KG/M2*S

N	Y (CM)	M	TT/TTE	D/DE	T/TE	U/UE
1	0.0000	0.0000	.9234	.4059	2.4636	0.0000
2	.0064	.5024	.9190	.4284	2.3342	.2658
3	.0114	.5431	.9228	.4301	2.3250	.2868
4	.0216	.5722	.9211	.4335	2.3066	.3009
5	.0267	.5961	.9206	.4361	2.2932	.3126
6	.0318	.6153	.9211	.4377	2.2845	.3220
7	.0394	.6389	.9216	.4399	2.2733	.3335
8	.0470	.6580	.9226	.4414	2.2654	.3429
9	.0546	.6775	.9224	.4436	2.2542	.3522
10	.0597	.6834	.9224	.4443	2.2509	.3550
11	.0622	.7394	.9233	.4503	2.2207	.3815
12	.1130	.8667	.9290	.4641	2.1548	.4405
13	.1638	.9340	.9334	.4716	2.1205	.4709
14	.2426	1.0127	.9372	.4820	2.0749	.5051
15	.3137	1.1039	.9424	.4946	2.0217	.5435
16	.3874	1.1639	.9455	.5038	1.9848	.5678
17	.4636	1.2466	.9494	.5175	1.9325	.6001
18	.5525	1.2823	.9499	.5243	1.9073	.6132
19	.6464	1.3579	.9554	.5370	1.8623	.6417
20	.7455	1.4258	.9619	.5481	1.8246	.6669
21	.8319	1.4854	.9661	.5591	1.7885	.6879
22	.9284	1.5440	.9686	.5714	1.7500	.7073
23	1.0300	1.6227	.9730	.5880	1.7005	.7327
24	1.1316	1.6796	.9751	.6013	1.6631	.7500
25	1.2179	1.7492	.9775	.6181	1.6179	.7704
26	1.3246	1.8352	.9805	.6397	1.5632	.7945
27	1.4440	1.9052	.9842	.6573	1.5214	.8137
28	1.5507	1.9745	.9875	.6755	1.4804	.8319
29	1.6574	2.0580	.9918	.6980	1.4327	.8530
30	1.7691	2.1338	.9944	.7202	1.3885	.8707
31	1.8961	2.2374	.9971	.7522	1.3294	.8933
32	2.0257	2.3332	1.0004	.7825	1.2779	.9133
33	2.1349	2.4360	1.0033	.8169	1.2241	.9332
34	2.2797	2.5399	1.0044	.8546	1.1701	.9513
35	2.3990	2.6013	1.0056	.8771	1.1401	.9618
36	2.5464	2.7092	1.0062	.9193	1.0878	.9784
37	2.6759	2.7729	1.0051	.9464	1.0566	.9870
38	2.8105	2.8240	1.0035	.9692	1.0318	.9933
* 39	3.3592	2.8873	.9995	1.0003	.9997	.9996
** 40	3.5395	2.8880	1.0000	1.0000	1.0000	1.0000
41	3.7198	2.8893	.9989	1.0017	.9983	.9996
42	3.9891	2.8905	.9990	1.0021	.9979	.9998
43	4.2278	2.8905	.9981	1.0030	.9970	.9994
44	4.7028	2.8939	.9970	1.0056	.9944	.9992
45	4.8832	2.8978	.9966	1.0077	.9923	.9995
46	5.0965	2.8983	.9966	1.0079	.9922	.9996
47	5.3632	2.8986	.9973	1.0073	.9927	1.0000
48	5.6096	2.8951	.9985	1.0046	.9955	1.0002
49	5.8534	2.8952	.9979	1.0052	.9948	.9999

NSWC TR 79-153

TABLE A-3 BOUNDARY LAYER PROFILE LISTING
RUN NO 802239

X = 1.981E+00 M	ME = 2.879E+00	DFL = 3.532E+00 CM
PO = 5.240E+04 N/M2	DE = 4.812E-02 KG/M3	DSTR = 1.400E+00 CM
TO = 3.182E+02 DEG.K	TE = 1.197E+02 DEG.K	TH = 2.641E-01 CM
PSW = 1.673E+03 N/M2	UE = 6.314E+02 M/S	TFF = 4.526E-01 CM
TW = 2.950E+02 N/M2	RE = 3.659E+06 1/M	THH = 1.852E-02 CM
TAUW = 1.637E+01 N/M2	CF = 1.708E-03	KETH = 2.453E+04
K = 1.245E-01 CM	MDOT = 1.465E-02 KG/M2*5	

N	Y (CM)	M	TT/TTE	D/DE	T/TE	U/UE
1	0.0000	0.0000	.9270	.4060	2.4633	0.0000
2	.0064	.4491	.9206	.4253	2.3512	.2392
3	.0114	.5086	.9254	.4277	2.3381	.2702
4	.0191	.5681	.9235	.4338	2.3052	.2997
5	.0292	.6000	.9206	.4382	2.2820	.3149
6	.0394	.6285	.9189	.4419	2.2628	.3284
7	.0495	.6451	.9179	.4441	2.2517	.3363
8	.0622	.6708	.9197	.4460	2.2422	.3489
9	.0724	.7204	.9226	.4502	2.2210	.3730
10	.0851	.7411	.9229	.4526	2.2096	.3827
11	.0953	.7703	.9222	.4565	2.1906	.3961
12	.1105	.7955	.9231	.4593	2.1773	.4078
13	.1232	.8239	.9238	.4627	2.1612	.4208
14	.1334	.8386	.9240	.4646	2.1524	.4274
15	.1461	.8577	.9252	.4666	2.1432	.4362
16	.1562	.8754	.9256	.4689	2.1326	.4441
17	.1689	.8931	.9270	.4707	2.1243	.4522
18	.1816	.9071	.9282	.4722	2.1178	.4586
19	.1969	.9241	.9306	.4735	2.1121	.4666
20	.2096	.9458	.9321	.4760	2.1009	.4762
21	.2197	.9580	.9327	.4775	2.0940	.4816
22	.2324	.9708	.9330	.4794	2.0860	.4871
23	.2426	.9746	.9330	.4800	2.0834	.4887
24	.2426	.9785	.9347	.4797	2.0844	.4908
25	.2604	1.0015	.9371	.4821	2.0741	.5010
26	.2807	1.0227	.9392	.4845	2.0638	.5104
27	.2985	1.0380	.9404	.4864	2.0559	.5171
28	.3162	1.0565	.9411	.4891	2.0444	.5248
29	.3340	1.0730	.9425	.4912	2.0357	.5318
30	.3543	1.0848	.9424	.4933	2.0271	.5365
31	.3772	1.0957	.9445	.4941	2.0239	.5415
32	.3772	1.1143	.9456	.4968	2.0128	.5492
33	.4534	1.1851	.9473	.5088	1.9653	.5771
34	.5499	1.2529	.9522	.5193	1.9256	.6040
35	.6312	1.3082	.9566	.5281	1.8938	.6254
36	.7379	1.3729	.9585	.5406	1.8497	.6486
37	.8090	1.4116	.9607	.5479	1.8253	.6625
38	.9081	1.4792	.9630	.5618	1.7799	.6856
39	1.0071	1.5363	.9671	.5729	1.7456	.7052
40	1.1214	1.6042	.9724	.5862	1.7059	.7279
41	1.2484	1.6909	.9747	.6069	1.6478	.7540
42	1.3526	1.7454	.9774	.6196	1.6139	.7703
43	1.4415	1.8007	.9795	.6334	1.5789	.7860
44	1.5354	1.8647	.9829	.6492	1.5404	.8040
45	1.6396	1.9296	.9865	.6656	1.5025	.8217
46	1.7336	1.9755	.9901	.6768	1.4775	.8342
47	1.7361	1.9971	.9899	.6834	1.4632	.8393
48	1.8529	2.0642	.9915	.7030	1.4225	.8553
49	1.9850	2.1540	.9948	.7294	1.3710	.8762
50	2.1247	2.2645	1.0000	.7623	1.3118	.9010

NSWC TR 79-153

TABLE A-3 BOUNDARY LAYER PROFILE LISTING
 RUN NO 802239 CONT.

N	Y (CM)	M	TT/TTE	D/DE	T/TE	U/UE
51	2.2187	2.3286	1.0000	.7845	1.2747	.9133
52	2.3635	2.4417	1.0014	.8239	1.2137	.9345
53	2.4930	2.5165	1.0038	.8498	1.1768	.9484
54	2.6530	2.6072	1.0061	.8825	1.1331	.9641
55	2.7750	2.6775	1.0074	.9092	1.0999	.9755
56	2.9147	2.7493	1.0055	.9401	1.0637	.9851
57	3.0594	2.8074	1.0034	.9663	1.0349	.9922
58	3.2195	2.8494	1.0032	.9843	1.0159	.9977
59	3.3566	2.8635	1.0043	.9893	1.0108	1.0002
* 60	3.5319	2.8743	1.0030	.9952	1.0049	1.0010
** 61	3.6919	2.8785	1.0000	1.0000	1.0000	1.0000
62	3.8545	2.8784	.9999	1.0000	1.0000	.9999
63	4.0399	2.8776	.9997	.9999	1.0001	.9997
64	4.2126	2.8772	1.0003	.9991	1.0009	1.0000
65	4.4107	2.8763	1.0029	.9962	1.0038	1.0011
66	4.5987	2.8812	1.0017	.9994	1.0006	1.0012
67	4.7841	2.8851	1.0014	1.0014	.9986	1.0016
68	4.9467	2.8855	1.0015	1.0015	.9985	1.0017
69	5.1524	2.8885	1.0019	1.0024	.9976	1.0023
70	5.3632	2.8905	1.0026	1.0026	.9974	1.0028
71	5.5664	2.8916	1.0046	1.0011	.9989	1.0040
72	5.8001	2.8847	1.0057	.9970	1.0030	1.0037
73	6.0617	2.8871	1.0035	1.0003	.9997	1.0028

NSWC TR 79-153

TABLE A-3 BOUNDARY LAYER PROFILE LISTING
RUN NO 802231

X = 1.981E+00 M ME = 2.909E+00 DEL = 2.775E+00 CM
 PO = 4.173E+05 N/M2 DE = 3.780E-01 KG/M3 DSTR = 1.096E+00 CM
 TO = 3.193E+02 DEG.K TE = 1.186E+02 DEG.K TH = 2.085E-01 CM
 PSW = 1.284E+04 N/M2 UE = 6.351E+02 M/S THE = 3.646E-01 CM
 TW = 3.043E+02 N/M2 RE = 2.918E+07 1/M THH = 1.097E-02 CM
 TAUW = 1.759E+02 N/M2 CF = 2.310E-03 RETH = 1.545E+05
 K = 1.245E-01 CM MDOT = 4.883E-02 KG/M2*S

N	Y (CM)	M	TT/TTE	D/DE	T/TF	U/UE
1	0.0000	0.0000	.9532	.3896	2.5669	0.0000
2	.0064	.6604	.9673	.4174	2.3960	.3514
3	.0089	.6687	.9670	.4184	2.3902	.3553
4	.0191	.7031	.9668	.4220	2.3695	.3720
5	.0318	.7456	.9683	.4261	2.3466	.3926
6	.0419	.7825	.9689	.4302	2.3246	.4100
7	.0521	.8213	.9703	.4344	2.3023	.4283
8	.0648	.8513	.9713	.4377	2.2846	.4423
9	.0775	.8890	.9720	.4424	2.2604	.4594
10	.0902	.9236	.9727	.4469	2.2377	.4748
11	.1054	.9541	.9732	.4510	2.2171	.4883
12	.1181	.9854	.9743	.4551	2.1972	.5020
13	.1334	1.0266	.9759	.4607	2.1706	.5198
14	.1486	1.0424	.9752	.4635	2.1574	.5262
15	.1638	1.0679	.9750	.4678	2.1379	.5367
16	.1918	1.1108	.9766	.4741	2.1094	.5545
17	.2172	1.1435	.9778	.4791	2.0874	.5679
18	.2375	1.1718	.9777	.4841	2.0656	.5788
19	.2731	1.2176	.9781	.4922	2.0316	.5965
20	.2985	1.2523	.9788	.4984	2.0066	.6097
21	.3391	1.2883	.9790	.5052	1.9794	.6230
22	.3569	1.3084	.9791	.5091	1.9642	.6303
23	.3797	1.3248	.9785	.5127	1.9505	.6359
24	.4051	1.3461	.9787	.5169	1.9346	.6435
25	.4153	1.3569	.9779	.5195	1.9247	.6470
26	.4305	1.3736	.9767	.5237	1.9096	.6524
27	.4864	1.4248	.9768	.5345	1.8709	.6698
28	.5982	1.4975	.9783	.5498	1.8188	.6941
29	.6744	1.5510	.9797	.5614	1.7812	.7115
30	.7506	1.6076	.9811	.5741	1.7418	.7292
31	.8649	1.6803	.9831	.5910	1.6921	.7513
32	.9995	1.7751	.9847	.6148	1.6266	.7781
33	1.2383	1.9412	.9891	.6584	1.5188	.8223
34	1.3500	2.0169	.9903	.6801	1.4705	.8406
35	1.4465	2.0924	.9914	.7025	1.4234	.8580
36	1.5659	2.1816	.9936	.7295	1.3708	.8779
37	1.6599	2.2486	.9943	.7511	1.3314	.8918
38	1.7488	2.3209	.9958	.7747	1.2909	.9063
39	1.8580	2.4046	.9969	.8033	1.2449	.9222
40	1.9774	2.4923	.9980	.8343	1.1986	.9378
41	2.0917	2.5845	1.0003	.8671	1.1532	.9540
42	2.2187	2.6631	1.0005	.8977	1.1140	.9661
43	2.3381	2.7505	1.0019	.9314	1.0737	.9796
44	2.4194	2.7903	1.0016	.9480	1.0548	.9850
45	2.5387	2.8419	1.0015	.9697	1.0313	.9919
46	2.6454	2.8758	1.0011	.9845	1.0158	.9962
* 47	2.7750	2.9004	1.0010	.9951	1.0050	.9993
** 48	2.9045	2.9094	1.0000	1.0000	1.0000	1.0000
49	3.0264	2.9112	.9988	1.0019	.9981	.9996
50	3.1458	2.9114	.9976	1.0032	.9968	.9991

NSWC TR 79-153

TABLE A-3 BOUNDARY LAYER PROFILE LISTING
RUN NO 802231 CONT.

N	Y (CM)	M	TT/TTE	D/De	T/TE	U/UE
51	3.3007	2.9106	.9964	1.0041	.9959	.9984
52	3.4379	2.9091	.9952	1.0047	.9953	.9976
53	3.5395	2.9079	.9934	1.0060	.9940	.9965
54	3.7402	2.9059	.9922	1.0064	.9937	.9956
55	4.1313	2.9059	.9910	1.0076	.9925	.9950
56	4.4971	2.9123	.9899	1.0114	.9887	.9953
57	4.8324	2.9176	.9889	1.0148	.9854	.9954
58	5.0940	2.9163	.9882	1.0149	.9853	.9950
59	5.3505	2.9150	.9870	1.0156	.9847	.9942
60	5.6985	2.9155	.9853	1.0176	.9827	.9934
61	6.2700	2.9026	.9838	1.0134	.9868	.9910
62	6.9177	2.9018	.9821	1.0149	.9853	.9900

NSWC TR 79-153

TABLE A-3 BOUNDARY LAYER PROFILE LISTING
RUN NO 802241

X = 1.981E+00 M ME = 2.902E+00 DEL = 3.049E+00 CM
 PO = 2.055E+05 N/M2 DE = 1.906E-01 KG/M3 DSTR = 1.247E+00 CM
 TO = 3.180E+02 DEG.K TE = 1.185E+02 DEG.K TH = 2.367E-01 CM
 PSW = 6.406E+03 N/M2 UE = 6.332E+02 M/S THE = 4.081E-01 CM
 TW = 2.942E+02 N/M2 RE = 1.469E+07 1/M THH = 1.999E-02 CM
 TAUW = 7.690E+01 N/M2 CF = 2.014E-03 RETH = 8.826E+04
 K = 1.245E-01 CM MDOT = 4.883E-02 KG/M2*5

N	Y (CM)	M	TT/TTE	D/DE	T/TE	U/UE
1	0.0000	0.0000	.9252	.4026	2.4837	0.0000
2	.0064	.5198	.9224	.4257	2.3493	.2745
3	.0114	.5372	.9232	.4268	2.3431	.2833
4	.0191	.5760	.9211	.4317	2.3190	.3022
5	.0267	.5921	.9192	.4337	2.3059	.3098
6	.0318	.6164	.9181	.4365	2.2903	.3214
7	.0394	.6368	.9171	.4391	2.2773	.3311
8	.0445	.6552	.9177	.4407	2.2689	.3401
9	.0597	.6998	.9207	.4447	2.2513	.3618
10	.0724	.7410	.9228	.4480	2.2323	.3815
11	.0851	.7738	.9230	.4519	2.2128	.3966
12	.0978	.8015	.9246	.4546	2.1996	.4096
13	.1130	.8345	.9265	.4580	2.1832	.4249
14	.1257	.8632	.9286	.4609	2.1695	.4381
15	.1410	.8972	.9314	.4643	2.1537	.4537
16	.1562	.9136	.9326	.4661	2.1455	.4611
17	.1689	.9400	.9349	.4689	2.1329	.4730
18	.1689	.9429	.9356	.4689	2.1325	.4744
19	.1867	.9713	.9370	.4725	2.1162	.4869
20	.2045	.9992	.9396	.4756	2.1025	.4992
21	.2172	1.0205	.9410	.4783	2.0908	.5084
22	.2299	1.0367	.9415	.4807	2.0804	.5152
23	.2451	1.0481	.9422	.4827	2.0739	.5201
24	.2477	1.0691	.9431	.4853	2.0608	.5288
25	.3137	1.1462	.9494	.4954	2.0184	.5611
26	.3772	1.2039	.9519	.5048	1.9811	.5839
27	.4661	1.2946	.9545	.5211	1.9191	.6179
28	.5804	1.3649	.9585	.5334	1.8748	.6439
29	.6769	1.4307	.9624	.5455	1.8332	.6674
30	.8090	1.5161	.9658	.5630	1.7762	.6962
31	.9055	1.5784	.9703	.5752	1.7386	.7171
32	1.1341	1.7268	.9772	.6085	1.6433	.7627
33	1.2687	1.8165	.9812	.6302	1.5868	.7884
34	1.3805	1.8901	.9832	.6496	1.5395	.8080
35	1.4973	1.9717	.9866	.6711	1.4901	.8293
36	1.6116	2.0601	.9890	.6963	1.4361	.8507
37	1.7285	2.1326	.9911	.7177	1.3933	.8674
38	1.8275	2.2122	.9935	.7419	1.3479	.8850
39	1.9444	2.2878	.9953	.7660	1.3055	.9007
40	2.0511	2.3857	.9980	.7981	1.2529	.9201
41	2.2390	2.5236	1.0003	.8467	1.1811	.9450
42	2.3686	2.6177	1.0003	.8827	1.1328	.9600
43	2.6124	2.7700	1.0026	.9416	1.0670	.9836
44	2.4651	2.6800	1.0021	.9056	1.1042	.9703
45	2.7242	2.8230	1.0023	.9640	1.0374	.9907
46	2.8791	2.8686	1.0017	.9834	1.0164	.9965
* 47	3.0493	2.8936	1.0002	.9961	1.0039	.9990
** 48	3.2068	2.9022	1.0000	1.0000	1.0000	1.0000
49	3.4862	2.9047	.9987	1.0023	.9977	.9997
50	3.6792	2.9051	1.0004	1.0008	.9992	1.0006

NSWC TR 79-153

TABLE A-3 BOUNDARY LAYER PROFILE LISTING
RUN NO 802241 CONT.

N	Y (CM)	M	TT/TTE	D/DE	T/TE	U/UE
51	3.9967	2.9052	1.0003	1.0009	.9991	1.0005
52	4.1720	2.9068	.9993	1.0027	.9973	1.0002
53	4.3396	2.9085	1.0000	1.0028	.9972	1.0008
54	4.5047	2.9115	.9996	1.0044	.9956	1.0010
55	4.7130	2.9156	.9995	1.0063	.9937	1.0014
56	4.9746	2.9202	1.0004	1.0073	.9927	1.0025
57	5.2464	2.9184	1.0009	1.0061	.9939	1.0025
58	5.4953	2.9115	1.0004	1.0037	.9964	1.0014
59	5.7722	2.9032	1.0009	.9996	1.0004	1.0006
60	5.9652	2.9017	1.0006	.9992	1.0003	1.0002
61	6.4478	2.8984	1.0023	.9961	1.0039	1.0006
62	6.6993	2.8977	1.0030	.9950	1.0050	1.0009

NSWC TR 79-153

TABLE A-3 BOUNDARY LAYER PROFILE LISTING
RUN NO 802242

X = 1.981E+00 M ME = 2.893E+00 DEL = 3.400E+00 CM
 PO = 1.037E+05 N/M2 DE = 9.777E-02 KG/M3 DSTR = 1.436E+00 CM
 TO = 3.150E+02 DEG.K TE = 1.178E+02 DEG.K TH = 2.639E-01 CM
 PSW = 3.282E+03 N/M2 UE = 6.294E+02 M/S THE = 4.479E-01 CM
 TW = 2.901E+02 N/M2 RE = 7.530E+06 1/M THH = 2.050E-02 CM
 TAUW = 3.323E+01 N/M2 CF = 1.717E-03 RETH = 5.043E+04
 K = 1.245E-01 CM MDOT = 4.883E-02 KG/M2*S

N	Y (CM)	M	TT/TTE	D/DE	T/TE	U/UE
1	0.0000	0.0000	.9211	.4060	2.4629	0.0000
2	.0064	.4477	.9160	.4247	2.3547	.2375
3	.0140	.4501	.9179	.4239	2.3588	.2389
4	.0216	.4874	.9168	.4273	2.3402	.2577
5	.0292	.5172	.9170	.4297	2.3273	.2727
6	.0394	.5488	.9185	.4317	2.3163	.2887
7	.0495	.5760	.9192	.4339	2.3047	.3023
8	.0495	.5746	.9170	.4348	2.3000	.3012
9	.0724	.6325	.9204	.4388	2.2787	.3300
10	.0902	.6871	.9208	.4445	2.2496	.3562
11	.1130	.7238	.9209	.4487	2.2288	.3735
12	.1308	.7561	.9233	.4514	2.2155	.3890
13	.1537	.7954	.9247	.4556	2.1948	.4073
14	.1740	.8226	.9249	.4591	2.1782	.4196
15	.1969	.8570	.9261	.4632	2.1589	.4353
16	.2248	.8917	.9280	.4671	2.1410	.4510
17	.2477	.9229	.9298	.4707	2.1243	.4649
18	.2705	.9475	.9313	.4737	2.1111	.4759
19	.2908	.9737	.9312	.4778	2.0930	.4869
20	.3112	.9903	.9315	.4803	2.0822	.4940
21	.3340	1.0112	.9334	.4826	2.0720	.5031
22	.3569	1.0336	.9355	.4852	2.0610	.5129
23	.3797	1.0522	.9361	.4880	2.0493	.5206
24	.4051	1.0741	.9378	.4908	2.0375	.5300
25	.4331	1.0966	.9400	.4936	2.0260	.5396
26	.4636	1.1192	.9406	.4972	2.0111	.5486
27	.4915	1.1362	.9424	.4993	2.0027	.5558
28	.5169	1.1527	.9440	.5015	1.9942	.5627
29	.5423	1.1700	.9448	.5042	1.9833	.5696
30	.5880	1.2023	.9469	.5092	1.9640	.5824
31	.6210	1.2238	.9482	.5126	1.9510	.5909
32	.6515	1.2524	.9503	.5170	1.9342	.6021
33	.7023	1.2820	.9537	.5210	1.9193	.6139
34	.7404	1.3051	.9549	.5251	1.9044	.6226
35	.7658	1.3218	.9556	.5281	1.8935	.6287
36	.8166	1.3593	.9573	.5351	1.8689	.6424
37	.8446	1.3712	.9582	.5371	1.8619	.6468
38	.8725	1.3922	.9598	.5407	1.8495	.6545
39	.9030	1.4069	.9619	.5428	1.8424	.6601
40	.9208	1.4189	.9616	.5456	1.8329	.6640
41	1.0579	1.5039	.9669	.5618	1.7801	.6936
42	1.2154	1.6157	.9723	.5855	1.7080	.7299
43	1.3145	1.6780	.9753	.5994	1.6683	.7492
44	1.4338	1.7625	.9802	.6186	1.6166	.7746
45	1.5507	1.8376	.9833	.6372	1.5693	.7957
46	1.6599	1.9093	.9861	.6558	1.5249	.8150
47	1.7717	1.9844	.9884	.6764	1.4784	.8341
48	1.8885	2.0786	.9926	.7024	1.4237	.8573
49	2.0053	2.1609	.9944	.7274	1.3748	.8758
50	2.1222	2.2535	.9969	.7562	1.3224	.8958

NSWC TR 79-153

TABLE A-3 BOUNDARY LAYER PROFILE LISTING
RUN NO 802242 CONT.

N	Y (CM)	M	TT/TTE	D/OE	T/TE	U/UE
51	2.2568	2.3565	1.0014	.7883	1.2686	.9175
52	2.4244	2.4698	1.0030	.8278	1.2081	.9384
53	2.6124	2.6085	1.0052	.8784	1.1384	.9621
54	2.7546	2.6980	1.0056	.9133	1.0949	.9759
55	2.9096	2.7839	1.0041	.9498	1.0528	.9874
56	3.0594	2.8398	1.0032	.9741	1.0266	.9946
57	3.2271	2.8747	1.0015	.9907	1.0094	.9984
* 58	3.3998	2.8893	1.0009	.9975	1.0025	1.0000
** 59	3.5801	2.8929	1.0000	1.0000	1.0000	1.0000
60	3.7808	2.8950	1.0004	1.0006	.9994	1.0005
61	3.9586	2.8974	.9998	1.0021	.9979	1.0005
62	4.1415	2.8982	.9999	1.0024	.9976	1.0006
63	4.3447	2.8982	1.0009	1.0013	.9987	1.0011
64	4.7308	2.8987	.9995	1.0030	.9970	1.0005
65	4.9517	2.9011	1.0014	1.0021	.9979	1.0018
66	5.2464	2.9059	1.0011	1.0045	.9955	1.0022
67	5.4674	2.9061	1.0010	1.0047	.9953	1.0022
68	5.8306	2.9049	1.0020	1.0032	.9968	1.0025
69	6.1963	2.9019	1.0023	1.0016	.9984	1.0023

NSWC TR 79-153

TABLE A-3 BOUNDARY LAYER PROFILE LISTING
RUN NO 802243

X = 1.981E+00 M ME = 2.873E+00 DEL = 3.814E+00 CM
 PO = 5.199E+04 N/M2 DE = 4.946E-02 KG/M3 DSTP = 1.742E+00 CM
 TO = 3.165E+02 DEG.K TE = 1.194E+02 DEG.K TH = 3.206E-01 CM
 PSW = 1.690E+03 N/M2 UE = 6.293E+02 M/S THE = 5.381E-01 CM
 TW = 2.913E+02 N/M2 RE = 3.758E+06 1/M THH = 3.448E-02 CM
 TAUW = 1.013E+01 N/M2 CF = 1.035E-03 RETH = 3.058E+04
 K = 1.245E-01 CM MDOT = 4.883E-02 KG/M2*S

N	Y(CM)	M	TT/TTE	D/DE	T/TE	U/UE
1	0.0000	0.0000	.9205	.4099	2.4395	0.0000
2	.0064	.3519	.9141	.4230	2.3642	.1884
3	.0114	.3585	.9174	.4218	2.3706	.1922
4	.0165	.3810	.9171	.4234	2.3619	.2038
5	.0216	.3992	.9167	.4247	2.3546	.2132
6	.0292	.4287	.9184	.4260	2.3476	.2287
7	.0394	.4645	.9188	.4284	2.3344	.2471
8	.0495	.5003	.9198	.4308	2.3215	.2653
9	.0648	.5257	.9203	.4327	2.3112	.2782
10	.0775	.5518	.9200	.4351	2.2982	.2912
11	.0902	.5743	.9194	.4375	2.2858	.3023
12	.1029	.5973	.9181	.4403	2.2711	.3134
13	.1257	.6348	.9171	.4446	2.2494	.3314
14	.1384	.6551	.9160	.4473	2.2359	.3410
15	.1486	.6722	.9158	.4492	2.2261	.3491
16	.1613	.6867	.9159	.4508	2.2182	.3561
17	.1689	.6995	.9148	.4528	2.2083	.3619
18	.1816	.7119	.9144	.4544	2.2005	.3676
19	.1918	.7291	.9147	.4564	2.1913	.3757
20	.2045	.7391	.9147	.4576	2.1855	.3804
21	.2146	.7530	.9142	.4595	2.1761	.3867
22	.2299	.7648	.9140	.4611	2.1688	.3921
23	.2426	.7821	.9155	.4625	2.1619	.4004
24	.2705	.8114	.9178	.4652	2.1495	.4141
25	.2959	.8375	.9206	.4673	2.1398	.4265
26	.3670	.8949	.9230	.4743	2.1085	.4524
27	.4534	.9594	.9274	.4817	2.0758	.4812
28	.5321	1.0221	.9316	.4896	2.0423	.5085
29	.6337	1.0749	.9367	.4959	2.0166	.5314
30	.6337	1.0842	.9370	.4974	2.0106	.5352
31	.7455	1.1489	.9382	.5084	1.9671	.5609
32	.8319	1.2024	.9417	.5165	1.9360	.5824
33	.9309	1.2492	.9455	.5236	1.9097	.6010
34	1.0173	1.2996	.9484	.5323	1.8788	.6201
35	1.1367	1.3634	.9520	.5437	1.8393	.6437
36	1.2484	1.4162	.9556	.5532	1.8076	.6628
37	1.2484	1.4309	.9554	.5567	1.7964	.6676
38	1.3475	1.4882	.9584	.5681	1.7603	.6874
39	1.4745	1.5700	.9615	.5859	1.7068	.7140
40	1.5634	1.6101	.9647	.5939	1.6838	.7273
41	1.6624	1.6743	.9662	.6095	1.6407	.7466
42	1.8098	1.7492	.9714	.6261	1.5972	.7696
43	1.9241	1.8338	.9752	.6472	1.5452	.7936
44	2.0231	1.8878	.9775	.6611	1.5126	.8082
45	2.1196	1.9568	.9815	.6788	1.4731	.8268
46	2.2212	2.0135	.9829	.6951	1.4386	.8407
47	2.3635	2.1070	.9861	.7224	1.3843	.8630
48	2.4549	2.1665	.9893	.7394	1.3524	.8771
49	2.5997	2.2584	.9935	.7672	1.3035	.8976
50	2.7216	2.3414	.9966	.7937	1.2599	.9149

NSWC TR 79-153

TABLE A-3 BOUNDARY LAYER PROFILE LISTING
RUN NO 802243 CONT.

N	Y (CM)	M	TT/ITE	D/DE	T/TE	U/UE
51	2.8512	2.4258	.9991	.8221	1.2163	.9314
52	2.9832	2.5170	1.0018	.8539	1.1711	.9482
53	3.1331	2.6208	1.0030	.8929	1.1199	.9655
54	3.2652	2.6930	1.0042	.9207	1.0862	.9770
55	3.4023	2.7555	1.0037	.9467	1.0562	.9859
56	3.5344	2.8068	1.0037	.9682	1.0328	.9930
57	3.6563	2.8330	1.0026	.9804	1.0200	.9960
* 58	3.8138	2.8593	1.0014	.9929	1.0072	.9990
59	3.9713	2.8673	1.0005	.9972	1.0028	.9996
60	4.1339	2.8729	1.0002	.9999	1.0001	1.0002
** 61	4.3117	2.8725	1.0000	1.0000	1.0000	1.0000
62	4.4971	2.8725	1.0003	.9997	1.0003	1.0001
63	4.6520	2.8709	1.0006	.9987	1.0013	1.0001
64	4.7917	2.8715	1.0019	.9977	1.0023	1.0008
65	4.9619	2.8725	1.0015	.9985	1.0015	1.0007
66	5.0838	2.8718	1.0013	.9983	1.0017	1.0006
67	5.1702	2.8737	1.0024	.9981	1.0019	1.0014
68	5.2769	2.8749	1.0031	.9980	1.0020	1.0018
69	5.4039	2.8787	1.0030	.9997	1.0003	1.0023
70	5.5309	2.8812	1.0028	1.0010	.9990	1.0025
71	5.6375	2.8814	1.0037	1.0002	.9998	1.0030
72	5.8153	2.8823	1.0040	1.0002	.9998	1.0033
73	6.0744	2.8832	1.0038	1.0008	.9992	1.0033
74	6.2700	2.8835	1.0033	1.0015	.9985	1.0031

NSWC TR 79-153

TABLE A-3 BOUNDARY LAYER PROFILE LISTING
RUN NO 802232

X = 1.981E+00 M ME = 2.901E+00 DEL = 3.037E+00 CM
 PO = 4.151E+05 N/M2 DE = 3.881E-01 KG/M3 DSTP = 1.223E+00 CM
 TO = 3.123E+02 DEG.K TE = 1.164E+02 DEG.K TH = 2.306E-01 CM
 PSW = 1.287E+04 N/M2 UE = 6.274E+02 M/S THF = 3.997E-01 CM
 TW = 2.993E+02 N/M2 RE = 3.015E+07 1/M THH = 1.398E-02 CM
 TAUW = 1.564E+02 N/M2 CF = 2.050E-03 RETH = 1.764E+05
 K = 1.245E-01 CM MDOT = 1.465E-01 KG/M2*_c

N	Y (CM)	M	TT/TTE	D/DE	T/TE	U/UE
1	0.0000	0.0000	.9586	.3887	2.5724	0.0000
2	.0064	.6107	.9655	.4147	2.4112	.3268
3	.0241	.6260	.9652	.4163	2.4020	.3344
4	.0368	.6676	.9650	.4206	2.3776	.3548
5	.0495	.7126	.9648	.4255	2.3504	.3765
6	.0622	.7546	.9652	.4300	2.3255	.3966
7	.0775	.7912	.9656	.4342	2.3029	.4138
8	.0902	.8268	.9665	.4383	2.2818	.4305
9	.1130	.8769	.9685	.4439	2.2526	.4536
10	.1257	.9032	.9705	.4466	2.2391	.4658
11	.1384	.9313	.9701	.4508	2.2184	.4781
12	.1562	.9680	.9705	.4559	2.1934	.4941
13	.1765	.9922	.9712	.4592	2.1776	.5046
14	.1943	1.0142	.9719	.4623	2.1631	.5141
15	.2045	1.0342	.9712	.4657	2.1471	.5223
16	.2197	1.0538	.9724	.4683	2.1354	.5307
17	.2400	1.0814	.9727	.4727	2.1154	.5421
18	.2680	1.1188	.9732	.4788	2.0887	.5573
19	.2908	1.1397	.9726	.4827	2.0718	.5654
20	.3162	1.1768	.9737	.4887	2.0463	.5802
21	.3366	1.1921	.9748	.4909	2.0371	.5864
22	.3645	1.2176	.9750	.4955	2.0182	.5962
23	.3848	1.2376	.9743	.4996	2.0015	.6035
24	.4153	1.2619	.9751	.5039	1.9847	.6127
25	.4305	1.2709	.9748	.5058	1.9772	.6159
26	.4407	1.2887	.9741	.5096	1.9623	.6222
27	.4534	1.2905	.9735	.5102	1.9598	.6227
28	.4763	1.3095	.9741	.5137	1.9466	.6297
29	.5753	1.3864	.9766	.5283	1.8930	.6575
30	.6820	1.4524	.9774	.5421	1.8448	.6799
31	.6820	1.4515	.9749	.5433	1.8407	.6788
32	.7887	1.5242	.9778	.5581	1.7917	.7032
33	.9081	1.6038	.9791	.5764	1.7350	.7281
34	.9995	1.6693	.9811	.5915	1.6907	.7481
35	1.0706	1.7027	.9815	.5998	1.6672	.7578
36	1.1646	1.7718	.9830	.6171	1.6204	.7774
37	1.2713	1.8423	.9844	.6355	1.5736	.7965
38	1.3754	1.9104	.9852	.6543	1.5283	.8140
39	1.4948	1.9993	.9877	.6789	1.4730	.8363
40	1.5913	2.0593	.9893	.6961	1.4365	.8507
41	1.6828	2.1404	.9909	.7206	1.3876	.8690
42	1.8098	2.2256	.9925	.7474	1.3380	.8873
43	1.9368	2.3200	.9942	.7782	1.2850	.9064
44	2.0765	2.4238	.9961	.8136	1.2291	.9262
45	2.1909	2.5098	.9968	.8448	1.1838	.9412
46	2.3838	2.6484	.9999	.8954	1.1168	.9646
47	2.6429	2.7992	1.0024	.9543	1.0479	.9876
48	2.7597	2.8441	1.0027	.9729	1.0279	.9938
49	2.9147	2.8774	1.0027	.9870	1.0131	.9982
* 50	3.0366	2.8932	1.0011	.9954	1.0046	.9995

NSWC TR 79-153

TABLE A-3 BOUNDARY LAYER PROFILE LISTING
RUN NO 802232 CONT.

N	Y (CM)	M	TT/TTE	D/DE	T/TE	U/UE
** 51	3.2144	2.9014	1.0000	1.0000	1.0000	1.0000
52	3.3846	2.9045	1.0001	1.0013	.9987	1.0004
53	3.5624	2.9046	1.0007	1.0007	.9993	1.0008
54	3.7198	2.9039	1.0000	1.0010	.9990	1.0003
55	3.8849	2.9026	.9982	1.0024	.9976	.9992
56	4.0627	2.9021	.9981	1.0022	.9978	.9992
57	4.2380	2.9023	.9981	1.0023	.9977	.9992
58	4.3777	2.9037	.9969	1.0041	.9959	.9988
59	4.5682	2.9061	.9964	1.0057	.9943	.9988
60	4.8451	2.9090	.9952	1.0082	.9919	.9986
61	5.1905	2.9102	.9946	1.0093	.9908	.9984
62	5.6807	2.9090	.9939	1.0094	.9906	.9979
63	6.1836	2.9036	.9926	1.0084	.9916	.9966
64	6.7145	2.9003	.9919	1.0077	.9924	.9958
65	7.1387	2.8971	.9894	1.0088	.9913	.9941
66	7.5603	2.8944	.9882	1.0089	.9912	.9932

NSWC TR 79-153

TABLE A-3 BOUNDARY LAYER PROFILE LISTING
RUN NO 802233

X = 1.981E+00 M	ME = 2.879E+00	DFL = 3.303E+00 CM
PO = 2.070E+05 N/M2	DE = 1.925E-01 KG/M3	DSTR = 1.428E+00 CM
TO = 3.170E+02 DEG.K	TE = 1.193E+02 DEG.K	TH = 2.809E-01 CM
PSW = 6.557E+03 N/M2	UE = 6.303E+02 M/S	THF = 4.802E-01 CM
TW = 2.977E+02 N/M2	RE = 1.467E+07 1/M	THH = 4.360E-02 CM
TAUW = 5.670E+01 N/M2	CF = 1.484E-03	RETH = 1.046E+05
K = 1.245E-01 CM	MDOT = 1.465E-01 KG/M2*5	

N	Y (CM)	M	TT/TTE	D/DE	T/TE	U/UE
1	0.0000	0.0000	.9391	.4006	2.4963	0.0000
2	.0064	.5052	.9396	.4208	2.3763	.2705
3	.0165	.5139	.9403	.4212	2.3740	.2750
4	.0216	.5364	.9411	.4228	2.3654	.2865
5	.0267	.5498	.9413	.4239	2.3593	.2933
6	.0368	.5754	.9405	.4265	2.3445	.3060
7	.0445	.6075	.9420	.4289	2.3317	.3222
8	.0572	.6393	.9419	.4321	2.3144	.3378
9	.0724	.6710	.9424	.4352	2.2979	.3533
10	.0826	.7038	.9434	.4383	2.2817	.3692
11	.0978	.7232	.9426	.4409	2.2683	.3783
12	.1105	.7544	.9437	.4440	2.2522	.3932
13	.1257	.7853	.9443	.4475	2.2344	.4077
14	.1410	.8087	.9453	.4500	2.2220	.4187
15	.1562	.8339	.9463	.4528	2.2083	.4304
16	.1740	.8595	.9468	.4560	2.1928	.4420
17	.1867	.8843	.9473	.4592	2.1775	.4532
18	.1994	.8997	.9488	.4607	2.1706	.4603
19	.2832	1.0049	.9511	.4755	2.1032	.5062
20	.3848	1.0872	.9524	.4884	2.0474	.5403
21	.4712	1.1557	.9546	.4994	2.0024	.5680
22	.5652	1.2214	.9562	.5108	1.9576	.5935
23	.6871	1.2972	.9569	.5255	1.9030	.6215
24	.7811	1.3586	.9579	.5378	1.8596	.6435
25	.8801	1.4112	.9592	.5484	1.8234	.6618
26	.9741	1.4742	.9603	.5621	1.7792	.6829
27	1.0757	1.5373	.9602	.5770	1.7331	.7029
28	1.1773	1.5862	.9609	.5886	1.6990	.7181
29	1.2738	1.6461	.9624	.6028	1.6590	.7364
30	1.3856	1.7154	.9630	.6206	1.6114	.7563
31	1.4923	1.7785	.9640	.6371	1.5695	.7738
32	1.6091	1.8446	.9656	.6547	1.5274	.7917
33	1.7056	1.9351	.9672	.6803	1.4700	.8149
34	1.8174	2.0057	.9678	.7015	1.4255	.8317
35	1.9241	2.0769	.9688	.7233	1.3825	.8481
36	2.0231	2.1451	.9709	.7441	1.3440	.8637
37	2.1374	2.2211	.9726	.7685	1.3013	.8800
38	2.2390	2.2929	.9748	.7918	1.2630	.8949
39	2.3533	2.3757	.9788	.8182	1.2222	.9122
40	2.4930	2.4750	.9820	.8525	1.1730	.9310
41	2.5845	2.5476	.9845	.8781	1.1388	.9442
42	2.6784	2.6156	.9888	.9011	1.1098	.9570
43	2.7800	2.6850	.9924	.9257	1.0803	.9692
44	2.8893	2.7428	.9935	.9485	1.0543	.9781
45	2.9883	2.7878	.9949	.9660	1.0352	.9851
46	3.0874	2.8227	.9979	.9778	1.0227	.9914
47	3.2093	2.8532	.9990	.9898	1.0103	.9960
* 48	3.3033	2.8683	.9998	.9954	1.0046	.9985
** 49	3.4455	2.8793	1.0000	1.0000	1.0000	1.0000
50	3.5649	2.8835	1.0007	1.0011	.9989	1.0009

NSWC TR 79-153

TABLE A-3 BOUNDARY LAYER PROFILE LISTING
 RUN NO 802233 CONT.

N	Y (CM)	M	TT/TTE	D/DE	T/TE	U/UE
51	3.7046	2.8853	1.0019	1.0007	.9993	1.0017
52	3.8087	2.8868	1.0001	1.0031	.9969	1.0010
53	3.9357	2.8884	.9996	1.0044	.9956	1.0010
54	4.0958	2.8903	.9984	1.0064	.9936	1.0006
55	4.2456	2.8922	.9972	1.0084	.9917	1.0003
56	4.4158	2.8945	.9967	1.0100	.9901	1.0003
57	4.6596	2.8956	.9961	1.0110	.9891	1.0002
58	4.8476	2.8975	.9955	1.0124	.9877	1.0001
59	5.0152	2.8979	.9950	1.0132	.9870	.9999
60	5.2642	2.8991	.9944	1.0143	.9859	.9998
61	5.5715	2.8971	.9949	1.0129	.9873	.9998
62	5.9449	2.8916	.9948	1.0106	.9895	.9990
63	6.4173	2.8917	.9948	1.0106	.9895	.9990
64	6.6129	2.8905	.9954	1.0095	.9906	.9992
65	7.0701	2.8847	.9965	1.0059	.9942	.9990
66	7.5933	2.8791	.9958	1.0041	.9959	.9979
67	7.8067	2.8751	.9946	1.0036	.9964	.9967

NSWC TR 79-153

TABLE A-3 BOUNDARY LAYER PROFILE LISTING
RUN NO 802244

X = 1.981E+00 M ME = 2.890E+00 DFL = 3.484E+00 CM
 PO = 2.059E+05 N/M2 DE = 1.938E-01 KG/M3 DSTR = 1.507E+00 CM
 TO = 3.149E+02 DEG.K TE = 1.179E+02 DEG.K TH = 2.804E-01 CM
 PSW = 6.509E+03 N/M2 UE = 6.291E+02 M/S THE = 4.756E-01 CM
 TW = 2.913E+02 N/M2 RE = 1.490E+07 1/M THH = 2.715E-02 CM
 TAUW = 5.726E+01 N/M2 CF = 1.495E-03 RETH = 1.060E+05
 K = 1.245E-01 CM MDOT = 1.465E-01 KG/M2*^c

N	Y (CM)	M	TT/TTE	D/DE	T/TE	U/UE
1	0.0000	0.0000	.9251	.4049	2.4700	0.0000
2	.0064	.4409	.9180	.4239	2.3593	.2343
3	.0165	.4735	.9210	.4249	2.3535	.2514
4	.0216	.4894	.9189	.4271	2.3412	.2591
5	.0267	.5060	.9166	.4295	2.3282	.2672
6	.0394	.5467	.9154	.4336	2.3062	.2873
7	.0546	.5807	.9155	.4367	2.2898	.3041
8	.0673	.6029	.9154	.4389	2.2786	.3150
9	.0775	.6307	.9153	.4418	2.2637	.3284
10	.0927	.6663	.9157	.4453	2.2454	.3455
11	.1105	.7036	.9156	.4495	2.2245	.3631
12	.1257	.7320	.9181	.4517	2.2140	.3769
13	.1588	.7801	.9190	.4572	2.1874	.3993
14	.1842	.8228	.9213	.4616	2.1665	.4191
15	.2070	.8515	.9228	.4647	2.1518	.4322
16	.2248	.8737	.9237	.4673	2.1397	.4423
17	.2553	.9089	.9250	.4719	2.1195	.4579
18	.2934	.9573	.9283	.4774	2.0947	.4795
19	.3061	.9657	.9284	.4786	2.0893	.4830
20	.3162	.9805	.9294	.4805	2.0814	.4895
21	.3340	.9888	.9308	.4810	2.0788	.4934
22	.3442	1.0053	.9316	.4833	2.0691	.5004
23	.3594	1.0203	.9322	.4854	2.0600	.5068
24	.3797	1.0300	.9350	.4855	2.0596	.5115
25	.4077	1.0552	.9393	.4875	2.0512	.5230
26	.4305	1.0752	.9402	.4904	2.0389	.5313
27	.4407	1.0851	.9419	.4913	2.0356	.5357
28	.4559	1.0936	.9426	.4924	2.0309	.5393
29	.4712	1.1037	.9435	.4937	2.0257	.5436
30	.4864	1.1209	.9448	.4960	2.0160	.5508
31	.5017	1.1265	.9456	.4966	2.0136	.5532
32	.5169	1.1323	.9463	.4972	2.0111	.5557
33	.5194	1.1371	.9464	.4981	2.0078	.5576
34	.5321	1.1484	.9471	.4997	2.0010	.5622
35	.5321	1.1533	.9461	.5011	1.9954	.5638
36	.6210	1.2129	.9506	.5099	1.9611	.5878
37	.7176	1.2733	.9538	.5200	1.9230	.6111
38	.8217	1.3312	.9573	.5299	1.8872	.6328
39	.9487	1.4092	.9601	.5450	1.8347	.6606
40	1.0376	1.4643	.9617	.5564	1.7971	.6793
41	1.1570	1.5412	.9657	.5721	1.7481	.7052
42	1.2814	1.6023	.9689	.5850	1.7094	.7249
43	1.3957	1.6713	.9698	.6020	1.6613	.7455
44	1.5329	1.7599	.9736	.6230	1.6052	.7716
45	1.6751	1.8407	.9787	.6420	1.5576	.7950
46	1.7844	1.9196	.9804	.6636	1.5070	.8155
47	1.8809	1.9857	.9831	.6814	1.4675	.8325
48	2.0003	2.0615	.9865	.7023	1.4239	.8513
49	2.1298	2.1698	.9917	.7333	1.3637	.8769
50	2.2593	2.2718	.9965	.7638	1.3093	.8996

NSWC TR 79-153

TABLE A-3 BOUNDARY LAYER PROFILE LISTING
RUN NO 802244 CONT.

N	Y (CM)	M	TT/TTE	D/DE	T/TE	U/UE
51	2.3787	2.3684	.9959	.7980	1.2532	.9175
52	2.5133	2.4544	.9985	.8270	1.2091	.9340
53	2.6530	2.5442	1.0006	.8589	1.1643	.9500
54	2.8283	2.6607	1.0024	.9026	1.1079	.9692
55	2.9553	2.7448	1.0032	.9359	1.0685	.9818
56	3.0798	2.7949	1.0022	.9575	1.0444	.9884
57	3.1941	2.8330	1.0030	.9728	1.0280	.9940
58	3.3338	2.8631	1.0015	.9871	1.0131	.9973
* 59	3.4836	2.8823	1.0001	.9967	1.0033	.9991
** 60	3.6284	2.8897	1.0000	1.0000	1.0000	1.0000
61	3.8037	2.8936	.9993	1.0024	.9976	1.0001
62	3.9561	2.8949	.9989	1.0034	.9966	1.0001
63	4.1516	2.8962	.9991	1.0037	.9963	1.0004
64	4.2964	2.8957	.9981	1.0046	.9955	.9998
65	4.4158	2.8956	.9978	1.0048	.9952	.9996
66	4.5606	2.8966	.9980	1.0050	.9950	.9999
67	4.7460	2.8998	.9988	1.0056	.9944	1.0007
68	4.8857	2.9029	.9983	1.0074	.9926	1.0009
69	5.0584	2.9050	.9985	1.0082	.9919	1.0012
70	5.1981	2.9071	.9967	1.0109	.9892	1.0006
71	5.3480	2.9078	.9978	1.0101	.9900	1.0012
72	5.4978	2.9085	.9976	1.0106	.9895	1.0012
73	5.7544	2.9056	.9981	1.0089	.9912	1.0011
74	6.0262	2.9002	.9974	1.0072	.9929	1.0001
75	6.4707	2.8958	.9966	1.0061	.9940	.9991

NSWC TR 79-153

TABLE A-3 BOUNDARY LAYER PROFILE LISTING
RUN NO 802245

X = 1.981E+00 M ME = 2.886E+00 DEL = 4.456E+00 CM
 PO = 1.033E+05 N/M2 DE = 9.868E-02 KG/M3 DSTR = 2.076E+00 CM
 TO = 3.169E+02 DEG.K TE = 1.189E+02 DEG.K TH = 3.559E-01 CM
 PSW = 3.337E+03 N/M2 UE = 6.308E+02 M/S THE = 5.845E-01 CM
 TW = 2.915E+02 N/M2 RE = 7.549E+06 1/M THH = 3.415E-02 CM
 TAUW = 1.373E+01 N/M2 CF = 6.998E-04 RETH = 6.819E+04
 K = 1.245E-01 CM MDOT = 1.465E-01 KG/M2*²C

N	Y (CM)	M	TT/TTE	D/DE	T/TE	U/UE
1	0.0000	0.0000	.9197	.4078	2.4521	0.0000
2	.0064	.2628	.9114	.4172	2.3969	.1410
3	.0165	.2834	.9130	.4174	2.3957	.1520
4	.0241	.3089	.9100	.4201	2.3806	.1651
5	.0343	.3337	.9103	.4212	2.3741	.1781
6	.0495	.3655	.9109	.4228	2.3654	.1948
7	.0597	.3797	.9106	.4238	2.3598	.2021
8	.0699	.3997	.9105	.4251	2.3523	.2124
9	.0800	.4142	.9106	.4261	2.3471	.2199
10	.0927	.4349	.9109	.4274	2.3399	.2305
11	.1080	.4581	.9107	.4292	2.3302	.2423
12	.1232	.4736	.9106	.4304	2.3235	.2501
13	.1359	.4971	.9110	.4321	2.3145	.2620
14	.1511	.5108	.9112	.4331	2.3089	.2689
15	.1715	.5379	.9118	.4352	2.2979	.2825
16	.1892	.5610	.9118	.4372	2.2871	.2940
17	.2070	.5768	.9115	.4389	2.2786	.3017
18	.2248	.6054	.9129	.4410	2.2676	.3158
19	.2934	.6639	.9141	.4465	2.2396	.3442
20	.3289	.6988	.9153	.4498	2.2232	.3610
21	.3747	.7321	.9158	.4535	2.2053	.3767
22	.4153	.7699	.9160	.4580	2.1834	.3942
23	.4763	.8025	.9180	.4612	2.1682	.4094
24	.5321	.8369	.9196	.4650	2.1504	.4252
25	.5753	.8656	.9206	.4685	2.1345	.4381
26	.6439	.9046	.9226	.4731	2.1138	.4557
27	.6845	.9231	.9234	.4754	2.1034	.4638
28	.7277	.9414	.9239	.4779	2.0924	.4718
29	.7658	.9672	.9247	.4815	2.0768	.4829
30	.8166	.9937	.9263	.4849	2.0623	.4944
31	.8674	1.0229	.9288	.4883	2.0478	.5072
32	.9385	1.0596	.9299	.4939	2.0246	.5224
33	1.0198	1.0962	.9329	.4987	2.0052	.5378
34	1.0935	1.1311	.9353	.5036	1.9856	.5522
35	1.1875	1.1816	.9381	.5115	1.9551	.5724
36	1.2408	1.2018	.9401	.5142	1.9446	.5807
37	1.2713	1.2163	.9410	.5165	1.9360	.5864
38	1.3170	1.2377	.9427	.5198	1.9239	.5948
39	1.3576	1.2602	.9448	.5231	1.9118	.6037
40	1.3957	1.2872	.9458	.5280	1.8940	.6138
41	1.4288	1.2976	.9455	.5303	1.8858	.6174
42	1.4821	1.3232	.9482	.5341	1.8723	.6273
43	1.5558	1.3664	.9513	.5415	1.8468	.6434
44	1.6320	1.4081	.9541	.5490	1.8215	.6584
45	1.6955	1.4380	.9548	.5553	1.8008	.6686
46	1.7640	1.4790	.9575	.5631	1.7759	.6829
47	1.8326	1.5144	.9614	.5691	1.7572	.6955
48	1.8936	1.5551	.9629	.5779	1.7303	.7087
49	1.9774	1.5984	.9659	.5867	1.7044	.7230
50	1.9799	1.6039	.9661	.5880	1.7007	.7247

NSWC TR 79-153

TABLE A-3 BOUNDARY LAYER PROFILE LISTING
RUN NO 802245 CONT.

N	Y (CM)	M	TT/TTE	D/DE	T/TE	U/UE
51	2.0434	1.6411	.9693	.5954	1.6795	.7369
52	2.0638	1.6657	.9704	.6010	1.6639	.7444
53	2.0942	1.6823	.9706	.6052	1.6523	.7492
54	2.1222	1.6990	.9725	.6084	1.6437	.7547
55	2.1781	1.7270	.9747	.6144	1.6276	.7634
56	2.2238	1.7599	.9766	.6220	1.6078	.7732
57	2.2746	1.7902	.9781	.6293	1.5891	.7819
58	2.3330	1.8244	.9801	.6375	1.5687	.7917
59	2.4244	1.8831	.9830	.6522	1.5333	.8079
60	2.4930	1.9283	.9852	.6639	1.5064	.8200
61	2.5591	1.9701	.9866	.6753	1.4808	.8306
62	2.6099	2.0073	.9889	.6849	1.4600	.8403
63	2.6708	2.0468	.9919	.6950	1.4389	.8506
64	2.6911	2.0598	.9928	.6984	1.4318	.8539
65	2.7165	2.0832	.9927	.7058	1.4168	.8591
66	2.7394	2.0931	.9929	.7088	1.4109	.8614
67	2.8918	2.2025	.9959	.7420	1.3477	.8859
68	3.0010	2.2973	.9978	.7727	1.2942	.9055
69	3.1610	2.4060	1.0001	.8093	1.2357	.9266
70	3.3007	2.5145	1.0041	.8459	1.1822	.9472
71	3.4658	2.6205	1.0060	.8849	1.1300	.9652
72	3.6690	2.7292	1.0074	.9270	1.0788	.9821
73	3.8519	2.7921	1.0053	.9549	1.0473	.9900
74	4.0246	2.8399	1.0043	.9759	1.0247	.9960
75	4.2405	2.8690	1.0026	.9900	1.0101	.9990
* 76	4.4564	2.8822	1.0014	.9969	1.0031	1.0002
** 77	4.6749	2.8862	1.0000	1.0000	1.0000	1.0000
78	4.8933	2.8879	1.0011	.9997	1.0003	1.0007
79	5.1168	2.8881	1.0011	.9997	1.0003	1.0008
80	5.2692	2.8876	1.0006	.9999	1.0001	1.0005
81	5.5105	2.8887	1.0013	.9997	1.0003	1.0010
82	5.8890	2.8885	1.0016	.9994	1.0006	1.0011
83	6.2446	2.8921	1.0018	1.0008	.9992	1.0017
84	6.5011	2.8935	1.0021	1.0011	.9989	1.0020
85	6.4986	2.8942	1.0021	1.0014	.9986	1.0021

NSWC TR 79-153

TABLE A-4 SKIN FRICTION DATA LISTING

N	PO*10-5 (N/M2)	TO (DEG.K)	M	RE (1/M)	RETH	TAUW (N/M2)	CF
RUN NO. 711211 K = 0.0000 CM MDOT = 0.0000 KG/M2S							
1	4.1665	320.0	2.940	2.893E+07	3.689E+04	8.405E+01	1.119E-03
2	4.1458	337.2	2.944	2.659E+07	3.469E+04	8.565E+01	1.149E-03
3	4.0934	357.2	2.944	2.412E+07	3.228E+04	8.701E+01	1.183E-03
4	3.8755	317.2	2.933	2.736E+07	3.525E+04	7.901E+01	1.124E-03
5	3.6680	318.3	2.938	2.570E+07	3.345E+04	7.470E+01	1.128E-03
6	2.8724	318.9	2.932	2.013E+07	2.750E+04	6.075E+01	1.166E-03
7	2.1008	331.7	2.942	1.382E+07	2.023E+04	4.595E+01	1.215E-03
8	2.0691	328.3	2.942	1.382E+07	2.024E+04	4.535E+01	1.218E-03
9	1.7609	327.8	2.940	1.180E+07	1.784E+04	3.961E+01	1.248E-03
10	1.4100	323.9	2.938	9.629E+06	1.505E+04	3.227E+01	1.267E-03
11	1.0356	325.6	2.934	7.034E+06	1.167E+04	2.492E+01	1.328E-03
12	1.0142	323.9	2.933	6.945E+06	1.159E+04	2.472E+01	1.344E-03
13	.7322	330.6	2.928	4.878E+06	8.666E+03	1.873E+01	1.404E-03
RUN NO. 711231 K = 0.0000 CM MDOT = 0.0000 KG/M2S							
1	4.1644	326.1	2.927	2.832E+07	3.587E+04	8.281E+01	1.091E-03
2	4.1300	319.4	2.916	2.912E+07	3.651E+04	8.155E+01	1.074E-03
3	3.9300	318.9	2.914	2.781E+07	3.493E+04	7.669E+01	1.059E-03
4	3.6887	327.8	2.925	2.491E+07	3.222E+04	7.375E+01	1.096E-03
5	3.1095	318.9	2.933	2.179E+07	2.895E+04	6.298E+01	1.117E-03
6	2.0822	313.3	2.923	1.506E+07	2.162E+04	4.539E+01	1.192E-03
RUN NO. 711281 K = 0.0000 CM MDOT = 0.0000 KG/M2S							
1	4.1884	316.1	2.933	2.973E+07	3.737E+04	8.279E+01	1.090E-03
2	3.8817	321.1	2.933	2.693E+07	3.447E+04	7.747E+01	1.100E-03
3	3.5067	318.9	2.930	2.461E+07	3.205E+04	7.082E+01	1.111E-03
4	3.3771	330.0	2.919	2.265E+07	3.009E+04	7.017E+01	1.133E-03
5	2.2367	343.9	2.931	1.404E+07	2.055E+04	4.966E+01	1.222E-03
6	1.7182	339.4	2.924	1.103E+07	1.675E+04	3.867E+01	1.232E-03
7	1.6010	337.8	2.920	1.038E+07	1.588E+04	3.609E+01	1.229E-03
8	1.3900	337.8	2.923	8.993E+06	1.413E+04	3.179E+01	1.251E-03
9	1.3031	336.7	2.921	8.480E+06	1.349E+04	3.022E+01	1.266E-03
10	1.0604	331.1	2.927	7.051E+06	1.159E+04	2.503E+01	1.295E-03
11	1.0604	345.6	2.927	6.623E+06	1.108E+04	2.570E+01	1.329E-03
12	1.0604	339.4	2.927	6.798E+06	1.129E+04	2.543E+01	1.315E-03
13	1.0563	326.1	2.927	7.182E+06	1.175E+04	2.479E+01	1.288E-03
14	1.0556	330.0	2.927	7.054E+06	1.161E+04	2.501E+01	1.300E-03
15	.2944	306.7	2.883	2.245E+06	4.550E+03	8.611E+00	1.548E-03
16	.2117	306.7	2.859	1.634E+06	3.548E+03	6.898E+00	1.690E-03
17	.1737	305.6	2.835	1.366E+06	3.058E+03	5.940E+00	1.739E-03
18	.1407	305.6	2.840	1.102E+06	2.580E+03	5.072E+00	1.842E-03
19	.1262	305.6	2.859	9.795E+05	2.346E+03	4.607E+00	1.894E-03
20	.1151	305.6	2.865	8.911E+05	2.180E+03	4.316E+00	1.954E-03
RUN NO. 711282 K = 0.0000 CM MDOT = 0.0000 KG/M2S							
1	4.1734	307.8	2.932	3.085E+07	3.838E+04	8.157E+01	1.076E-03
2	4.1713	310.6	2.931	3.043E+07	3.801E+04	8.199E+01	1.082E-03
3	3.1606	322.8	2.926	2.184E+07	2.901E+04	6.446E+01	1.118E-03
4	2.1112	317.2	2.919	1.502E+07	2.134E+04	4.479E+01	1.156E-03
5	1.0632	326.1	2.926	7.234E+06	1.185E+04	2.510E+01	1.294E-03
6	.9005	322.8	2.920	6.239E+06	1.057E+04	2.218E+01	1.344E-03
7	.8060	322.8	2.919	5.589E+06	9.643E+03	2.011E+01	1.360E-03
8	.7074	322.8	2.920	4.902E+06	8.690E+03	1.813E+01	1.398E-03

NSWC TR 79-153

TABLE A-4 SKIN FRICTION DATA LISTING

N	P0*10-5 (N/M2)	TO (DFG.K)	M	RE (1/M)	RETH	TAIW (N/M2)	CF
RUN NO. 712011 K = 0.0000 CM MDOT = 0.0000 KG/M2S							
1	4.1217	320.6	2.934	2.864E+07	3.652E+04	8.327E+01	1.115E-03
2	3.0916	318.3	2.927	2.179E+07	2.915E+04	6.407E+01	1.137E-03
3	2.0733	318.3	2.922	1.465E+07	2.121E+04	4.575E+01	1.205E-03
4	1.8030	346.1	2.937	1.117E+07	1.706E+04	4.094E+01	1.256E-03
5	1.6658	346.1	2.944	1.028E+07	1.595E+04	3.806E+01	1.272E-03
6	1.3769	346.1	2.935	8.539E+06	1.365E+04	3.207E+01	1.287E-03
7	1.2452	346.1	2.943	7.690E+06	1.253E+04	2.926E+01	1.306E-03
8	1.1073	346.1	2.942	6.842E+06	1.149E+04	2.707E+01	1.358E-03
9	1.0384	320.6	2.927	7.242E+06	1.208E+04	2.576E+01	1.361E-03
10	.8729	337.8	2.927	5.636E+06	9.662E+03	2.131E+01	1.339E-03
11	.7212	320.0	2.925	5.049E+06	8.808E+03	1.778E+01	1.350E-03
12	.6881	332.2	2.918	4.573E+06	8.157E+03	1.752E+01	1.387E-03
13	.6619	323.9	2.924	4.553E+06	8.043E+03	1.627E+01	1.345E-03
14	.6571	320.0	2.908	4.640E+06	8.216E+03	1.660E+01	1.365E-03
15	.6322	319.4	2.914	4.463E+06	7.983E+03	1.613E+01	1.385E-03
16	.6081	322.2	2.919	4.227E+06	7.639E+03	1.560E+01	1.398E-03
17	.5792	322.2	2.916	4.031E+06	7.367E+03	1.511E+01	1.419E-03
18	.5530	322.2	2.919	3.844E+06	7.106E+03	1.462E+01	1.441E-03
19	.5516	319.4	2.909	3.903E+06	7.180E+03	1.457E+01	1.429E-03
20	.5295	321.1	2.921	3.696E+06	6.878E+03	1.404E+01	1.447E-03
21	.5185	320.6	2.920	3.631E+06	6.792E+03	1.388E+01	1.460E-03
22	.4861	318.3	2.899	3.476E+06	6.505E+03	1.304E+01	1.438E-03
23	.4854	319.4	2.915	3.424E+06	6.513E+03	1.339E+01	1.499E-03
24	.4337	318.3	2.891	3.115E+06	5.971E+03	1.206E+01	1.480E-03
25	.4006	318.3	2.890	2.878E+06	5.602E+03	1.132E+01	1.504E-03
26	.3558	313.3	2.872	2.642E+06	5.183E+03	1.012E+01	1.491E-03
27	.2916	313.3	2.848	2.193E+06	4.471E+03	8.846E+00	1.560E-03
28	.2489	313.3	2.843	1.877E+06	3.956E+03	7.910E+00	1.628E-03
29	.2110	313.3	2.832	1.600E+06	3.492E+03	7.085E+00	1.705E-03
30	.1896	313.3	2.827	1.442E+06	3.235E+03	6.684E+00	1.781E-03
RUN NO. 801231 K = .0102 CM MDOT = 0.0000 KG/M2S							
1	3.1316	322.8	2.937	2.150E+07	3.044E+04	7.402E+01	1.308E-03
2	3.1185	319.1	2.937	2.179E+07	3.076E+04	7.351E+01	1.304E-03
3	3.1144	326.6	2.937	2.101E+07	2.988E+04	7.379E+01	1.311E-03
4	3.0854	328.3	2.937	2.066E+07	2.945E+04	7.309E+01	1.311E-03
5	3.0523	329.4	2.937	2.033E+07	2.914E+04	7.286E+01	1.321E-03
6	3.0206	329.3	2.937	2.014E+07	2.887E+04	7.196E+01	1.318E-03
7	3.0068	320.9	2.936	2.084E+07	2.952E+04	7.048E+01	1.295E-03
8	2.9841	326.8	2.936	2.013E+07	2.871E+04	7.027E+01	1.302E-03
9	2.9792	322.6	2.936	2.049E+07	2.915E+04	7.016E+01	1.301E-03
10	2.7531	313.9	2.932	1.975E+07	2.806E+04	6.394E+01	1.280E-03
11	2.5097	316.8	2.930	1.778E+07	2.549E+04	5.756E+01	1.262E-03
12	2.3601	323.4	2.933	1.619E+07	2.372E+04	5.520E+01	1.290E-03
13	2.1967	323.0	2.933	1.510E+07	2.231E+04	5.127E+01	1.287E-03
14	2.1263	322.3	2.932	1.467E+07	2.178E+04	4.975E+01	1.289E-03
15	2.0795	320.4	2.933	1.447E+07	2.148E+04	4.838E+01	1.283E-03
16	2.0767	320.8	2.933	1.442E+07	2.143E+04	4.836E+01	1.284E-03
17	2.0622	319.2	2.932	1.443E+07	2.145E+04	4.810E+01	1.285E-03
18	2.0615	320.6	2.933	1.433E+07	2.131E+04	4.801E+01	1.284E-03
19	2.0560	320.6	2.933	1.429E+07	2.128E+04	4.799E+01	1.287E-03
20	2.0546	319.6	2.933	1.434E+07	2.134E+04	4.787E+01	1.285E-03
21	2.0505	318.9	2.934	1.436E+07	2.139E+04	4.794E+01	1.290E-03
22	1.7961	309.0	2.925	1.324E+07	1.973E+04	4.110E+01	1.254E-03
23	1.5837	308.8	2.922	1.171E+07	1.774E+04	3.632E+01	1.253E-03
24	1.5258	320.6	2.932	1.061E+07	1.652E+04	3.599E+01	1.300E-03
25	1.5182	318.3	2.927	1.070E+07	1.658E+04	3.558E+01	1.286E-03

NSWC TR 79-153

TABLE A-4 SKIN FRICTION DATA LISTING

N	P0*10-5 (N/M2)	TO (DEG.K)	M	RE (1/M)	RETH	TAUW (N/M2)	CF
RUN NO.	801231	K =	.0102 CM	MDOT = 0.0000	KG/M2S		
26	1.4555	320.8	2.930	1.012E+07	1.589E+04	3.451E+01	1.305E-03
27	1.4445	315.5	2.927	1.032E+07	1.606E+04	3.382E+01	1.285E-03
28	1.4355	317.0	2.929	1.017E+07	1.588E+04	3.368E+01	1.289E-03
29	1.3417	319.1	2.928	9.421E+06	1.494E+04	3.192E+01	1.306E-03
30	1.2914	320.0	2.927	9.028E+06	1.440E+04	3.072E+01	1.306E-03
31	1.2480	320.4	2.927	8.711E 06	1.398E+04	2.982E+01	1.311E-03
32	1.2224	320.8	2.928	8.515E+06	1.371E+04	2.924E+01	1.313E-03
33	1.1473	319.6	2.925	8.044E+06	1.308E+04	2.762E+01	1.319E-03
34	1.1025	320.2	2.926	7.705E+06	1.264E+04	2.677E+01	1.331E-03
35	1.0873	321.1	2.927	7.564E+06	1.245E+04	2.644E+01	1.334E-03
36	.8446	320.2	2.925	5.909E+06	1.017E+04	2.124E+01	1.377E-03
37	.8336	319.8	2.924	5.844E+06	1.003E+04	2.076E+01	1.363E-03
38	.8198	321.1	2.924	5.712E+06	9.850E+03	2.050E+01	1.369E-03
39	.8170	318.9	2.925	5.749E+06	9.932E+03	2.057E+01	1.380E-03
40	.8170	320.4	2.925	5.709E+06	9.876E+03	2.060E+01	1.381E-03
41	.8025	316.8	2.925	5.703E+06	9.834E+03	2.004E+01	1.368E-03
42	.7991	322.5	2.925	5.532E+06	9.618E+03	2.020E+01	1.384E-03
43	.7929	323.0	2.925	5.474E+06	9.538E+03	2.009E+01	1.388E-03
44	.7908	322.6	2.924	5.472E+06	9.530E+03	2.002E+01	1.385E-03
45	.7543	314.3	2.928	5.414E+06	9.453E+03	1.909E+01	1.390E-03
46	.7495	319.2	2.918	5.284E+06	9.226E+03	1.896E+01	1.378E-03
47	.7115	319.1	2.920	5.017E+06	8.854E+03	1.817E+01	1.392E-03
48	.6909	320.0	2.920	4.850E+06	8.620E+03	1.778E+01	1.403E-03
49	.6881	311.3	2.930	5.006E+06	8.850E+03	1.750E+01	1.398E-03
50	.6109	321.9	2.919	4.254E+06	7.774E+03	1.623E+01	1.447E-03
51	.5840	322.1	2.916	4.069E+06	7.476E+03	1.553E+01	1.446E-03
52	.5412	321.3	2.916	3.783E+06	7.046E+03	1.456E+01	1.463E-03
53	.5137	319.4	2.910	3.634E+06	6.810E+03	1.394E+01	1.468E-03
54	.4964	319.1	2.912	3.514E+06	6.643E+03	1.362E+01	1.487E-03
55	.4916	319.2	2.913	3.475E+06	6.579E+03	1.348E+01	1.487E-03
56	.4847	320.2	2.914	3.410E+06	6.482E+03	1.334E+01	1.493E-03
57	.4599	320.4	2.908	3.242E+06	6.213E+03	1.278E+01	1.502E-03
58	.4151	320.6	2.902	2.934E+06	5.714E+03	1.172E+01	1.517E-03
59	.3799	320.8	2.901	2.683E+06	5.327E+03	1.098E+01	1.553E-03
60	.3392	319.8	2.895	2.414E+06	4.886E+03	1.003E+01	1.581E-03
61	.3213	319.4	2.895	2.292E+06	4.686E+03	9.616E+00	1.599E-03
62	.3013	318.9	2.894	2.156E+06	4.463E+03	9.154E+00	1.622E-03
63	.2923	318.7	2.895	2.092E+06	4.352E+03	8.900E+00	1.626E-03
64	.2792	318.1	2.893	2.006E+06	4.204E+03	8.576E+00	1.638E-03
65	.2675	317.5	2.893	1.926E+06	4.071E+03	8.299E+00	1.656E-03
66	.2530	317.7	2.889	1.824E+06	3.902E+03	7.998E+00	1.681E-03
67	.2392	317.7	2.885	1.728E+06	3.731E+03	7.652E+00	1.695E-03
68	.2151	318.1	2.881	1.555E+06	3.432E+03	7.097E+00	1.742E-03
69	.1993	319.2	2.881	1.433E+06	3.210E+03	6.681E+00	1.771E-03
70	.1875	319.1	2.872	1.356E+06	3.069E+03	6.403E+00	1.791E-03
71	.1731	318.9	2.865	1.257E+06	2.885E+03	6.033E+00	1.818E-03

NSWC TR 79-153

TABLE A-4 SKIN FRICTION DATA LISTING

N	PO*10-5 (N/M2)	TO (DEG.K)	M	RE (1/M)	RETH	TAUW (N/M2)	CF
RUN NO. 801241 K = .0102 CM MDOT = 0.0000 KG/M2S							
1	4.0900	322.5	2.932	2.821E+07	3.936E+04	1.024E+02	1.380E-03
2	3.7480	319.2	2.928	2.629E+07	3.678E+04	9.268E 01	1.358E-03
3	3.5343	321.3	2.930	2.452E+07	3.468E+04	8.749E+01	1.362E-03
4	3.2757	323.6	2.927	2.253E+07	3.213E+04	8.065E+01	1.351E-03
5	3.1585	326.2	2.929	2.144E+07	3.083E+04	7.791E+01	1.356E-03
6	3.1130	327.0	2.929	2.106E+07	3.040E+04	7.706E+01	1.360E-03
7	3.1130	327.7	2.929	2.099E+07	3.026E+04	7.678E+01	1.355E-03
8	3.0902	328.3	2.929	2.078E+07	3.005E+04	7.647E+01	1.360E-03
9	3.0599	326.4	2.927	2.077E+07	2.990E+04	7.498E+01	1.345E-03
10	3.0585	328.9	2.929	2.052E+07	2.978E+04	7.609E+01	1.367E-03
11	3.0323	331.1	2.929	2.013E+07	2.927E+04	7.522E+01	1.364E-03
12	3.0268	328.5	2.928	2.035E+07	2.948E+04	7.482E+01	1.358E-03
13	2.7524	321.7	2.924	1.912E+07	2.779E+04	6.736E+01	1.340E-03
14	2.4125	323.0	2.923	1.667E+07	2.467E+04	5.898E+01	1.337E-03
15	2.2353	329.1	2.922	1.504E+07	2.266E+04	5.525E+01	1.351E-03
16	2.1153	332.1	2.922	1.404E+07	2.137E+04	5.240E+01	1.353E-03
17	2.0705	337.0	2.924	1.343E+07	2.064E+04	5.164E+01	1.366E-03
18	2.0367	322.3	2.924	1.412E+07	2.143E+04	5.011E+01	1.346E-03
19	2.0236	320.8	2.923	1.413E+07	2.142E+04	4.966E+01	1.342E-03
20	2.0215	319.2	2.924	1.421E+07	2.146E+04	4.923E+01	1.333E-03
21	2.0209	320.2	2.924	1.414E+07	2.141E+04	4.945E+01	1.339E-03
22	2.0209	319.6	2.924	1.418E+07	2.146E+04	4.942E+01	1.338E-03
23	2.0146	317.7	2.923	1.427E+07	2.149E+04	4.883E+01	1.326E-03
24	1.6499	311.1	2.914	1.211E+07	1.862E+04	4.005E+01	1.318E-03
RUN NO. 801271 K = .0102 CM MDOT = 0.0000 KG/M2S							
1	.7481	318.9	2.912	5.301E+06	9.222E+03	1.884E+01	1.365E-03
2	.7157	324.9	2.924	4.901E+06	8.685E+03	1.827E+01	1.397E-03
3	.7143	318.9	2.910	5.066E+06	8.886E+03	1.813E+01	1.373E-03
4	.6743	324.0	2.916	4.38E+06	8.321E+03	1.740E+01	1.403E-03
5	.6509	325.1	2.921	4.460E+06	8.058E+03	1.699E+01	1.425E-03
6	.6502	320.0	2.908	4.593E+06	8.212E+03	1.684E+01	1.399E-03
7	.6212	325.1	2.915	4.270E+06	7.759E+03	1.630E+01	1.426E-03
8	.6123	320.2	2.902	4.334E+06	7.821E+03	1.601E+01	1.405E-03
9	.5916	324.2	2.921	4.072E+06	7.474E+03	1.563E+01	1.442E-03
10	.5619	320.0	2.902	3.982E+06	7.306E+03	1.494E+01	1.428E-03
11	.5571	324.0	2.911	3.857E+06	7.126E+03	1.481E+01	1.440E-03
12	.5516	321.1	2.901	3.890E+06	7.165E+03	1.471E+01	1.432E-03
13	.5399	321.3	2.900	3.805E 06	7.038E+03	1.445E+01	1.437E-03
14	.5385	323.8	2.916	3.721E+06	6.940E+03	1.445E+01	1.460E-03
15	.5233	321.7	2.899	3.685E+06	6.848E+03	1.406E+01	1.440E-03
16	.4992	321.9	2.906	3.499E+06	6.574E+03	1.350E+01	1.459E-03
17	.4750	321.1	2.908	3.338E+06	6.326E+03	1.292E+01	1.469E-03
18	.4440	319.4	2.907	3.146E+06	6.039E+03	1.228E+01	1.492E-03
19	.3916	315.8	2.896	2.838E+06	5.534E+03	1.101E+01	1.504E-03
20	.3751	314.9	2.897	2.730E+06	5.361E+03	1.061E+01	1.514E-03
21	.3551	313.8	2.901	2.592E+06	5.141E+03	1.011E+01	1.529E-03
22	.3234	311.5	2.908	2.377E+06	4.806E+03	9.386E+00	1.568E-03

NSWC TR 79-153

TABLE A-4 SKIN FRICTION DATA LISTING

N	PO*10-5 (N/M2)	TO (DFG.K)	M	RE (1/M)	RETH	TAUW (N/M2)	CF
RUN NO. 801242 K = .0102 CM MDOT = .0146 KG/M2S							
1	4.0900	323.8	2.932	2.803E+07	3.993E+04	9.769E+01	1.316E-03
2	3.1302	328.3	2.928	2.106E+07	3.110E+04	7.236E+01	1.269E-03
3	3.1102	322.5	2.929	2.148E+07	3.181E+04	7.286E+01	1.287E-03
4	3.0875	322.8	2.929	2.129E+07	3.151E+04	7.199E+01	1.281E-03
5	3.0751	319.8	2.928	2.151E+07	3.160E+04	7.062E+01	1.261E-03
6	3.0633	318.3	2.928	2.158E+07	3.181E+04	7.104E+01	1.274E-03
7	3.0551	319.1	2.928	2.144E+07	3.159E+04	7.055E+01	1.268E-03
8	3.0516	319.2	2.928	2.140E+07	3.144E+04	6.986E+01	1.258E-03
9	2.8751	313.9	2.924	2.072E+07	3.056E+04	6.559E+01	1.248E-03
10	2.0450	322.5	2.924	1.416E+07	2.227E+04	4.562E+01	1.221E-03
11	2.0388	320.9	2.924	1.422E+07	2.233E+04	4.539E+01	1.218E-03
12	2.0333	318.3	2.924	1.436E+07	2.246E+04	4.494E+01	1.209E-03
13	2.0264	319.4	2.923	1.424E+07	2.231E+04	4.482E+01	1.210E-03
14	2.0250	317.0	2.923	1.439E+07	2.252E+04	4.484E+01	1.211E-03
15	2.0236	317.3	2.923	1.436E+07	2.252E+04	4.503E+01	1.217E-03
16	1.0177	313.9	2.910	7.385E+06	1.319E+04	2.157E+01	1.147E-03
17	.9880	320.9	2.915	6.924E+06	1.259E+04	2.119E+01	1.165E-03
18	.9860	319.8	2.914	6.948E+06	1.256E+04	2.079E+01	1.145E-03
19	.9825	318.5	2.914	6.966E+06	1.263E+04	2.091E+01	1.155E-03
20	.9784	317.3	2.914	6.975E+06	1.265E+04	2.089E+01	1.159E-03
21	.9735	317.3	2.914	6.939E+06	1.260E+04	2.077E+01	1.158E-03
22	.9729	317.5	2.914	6.927E+06	1.257E+04	2.063E+01	1.151E-03
23	.9722	318.3	2.914	6.899E+06	1.254E+04	2.070E+01	1.156E-03
RUN NO. 801272 K = .0102 CM MDOT = .0146 KG/M2S							
1	.8494	321.9	2.914	5.930E+06	1.102E+04	1.711E+01	1.093E-03
2	.8329	322.3	2.913	5.808E+06	1.086E+04	1.688E+01	1.099E-03
3	.8198	322.6	2.912	5.709E+06	1.073E+04	1.665E+01	1.100E-03
4	.8060	322.6	2.911	5.615E+06	1.057E+04	1.621E+01	1.089E-03
5	.7674	322.1	2.908	5.370E+06	1.023E+04	1.548E+01	1.089E-03
6	.7364	322.1	2.908	5.153E+06	9.917E+03	1.476E+01	1.082E-03
7	.7150	322.3	2.906	5.002E+06	9.697E+03	1.429E+01	1.078E-03
8	.6943	321.7	2.903	4.879E+06	9.516E+03	1.387E+01	1.074E-03
9	.6674	320.8	2.901	4.716E+06	9.279E+03	1.328E+01	1.069E-03
10	.6385	319.8	2.896	4.542E+06	8.999E+03	1.253E+01	1.050E-03
11	.5916	318.9	2.895	4.230E+06	8.557E+03	1.159E+01	1.047E-03
12	.5543	318.1	2.889	3.991E+06	8.179E+03	1.070E+01	1.026E-03
13	.5068	317.5	2.881	3.673E+06	7.702E+03	9.722E+00	1.013E-03
14	.4785	317.5	2.876	3.477E+06	7.412E+03	9.184E+00	1.010E-03
15	.4482	317.5	2.873	3.262E+06	7.083E+03	8.534E+00	9.990E-04
16	.4220	317.3	2.863	3.090E+06	6.794E+03	7.903E+00	9.747E-04
17	.3889	317.2	2.859	2.857E+06	6.436E+03	7.219E+00	9.628E-04
18	.3640	317.3	2.853	2.680E+06	6.172E+03	6.794E+00	9.635E-04
19	.3399	317.7	2.849	2.503E+06	5.888E+03	6.265E+00	9.483E-04
20	.3185	317.5	2.837	2.363E+06	5.657E+03	5.840E+00	9.343E-04

NSWC TR 79-153

TABLE A-4 SKIN FRICTION DATA LISTING

N	P0*10-5 (N/M2)	TO (DEG.K)	M	RE (1/M)	RETH	TAUW (N/M2)	CF
RUN NO. 801243 K = .0102 CM MDOT = .0488 KG/M2S							
1	4.0686	318.1	2.930	2.865E+07	4.289E+04	8.841E+01	1.196F-03
2	4.0541	318.1	2.931	2.854E+07	4.275E+04	8.796E+01	1.194F-03
3	3.7356	311.9	2.931	2.708E+07	4.088E+04	7.918E+01	1.167E-03
4	3.2998	313.8	2.924	2.380E+07	3.652E+04	6.686E+01	1.109E-03
5	3.1475	320.0	2.926	2.202E+07	3.461E+04	6.474E+01	1.128E-03
6	3.0971	322.6	2.927	2.140E+07	3.381E+04	6.337E+01	1.122E-03
7	3.0944	319.2	2.926	2.172E+07	3.415E+04	6.287E+01	1.114E-03
8	3.0854	322.3	2.927	2.135E+07	3.381E+04	6.337E+01	1.127E-03
9	3.0771	315.6	2.927	2.196E+07	3.447E+04	6.243E+01	1.113E-03
10	3.0744	317.7	2.927	2.173E+07	3.418E+04	6.238E+01	1.113E-03
11	2.3091	317.3	2.922	1.639E+07	2.740E+04	4.350E+01	1.029E-03
12	2.1843	315.3	2.921	1.566E+07	2.645E+04	4.034E+01	1.008E-03
13	2.1126	315.6	2.921	1.512E+07	2.581E+04	3.892E+01	1.006E-03
14	2.0864	316.2	2.921	1.490E+07	2.553E+04	3.840E+01	1.005E-03
15	2.0705	315.5	2.921	1.483E+07	2.541E+04	3.774E+01	9.953E-04
16	2.0684	315.6	2.921	1.481E+07	2.539E+04	3.779E+01	9.976E-04
17	2.0657	315.3	2.921	1.481E+07	2.540E+04	3.774E+01	9.976E-04
18	2.0608	315.5	2.921	1.477E+07	2.537E+04	3.779E+01	1.001E-03
19	1.9119	310.0	2.909	1.415E+07	2.440E+04	3.356E+01	9.492E-04
20	1.0563	320.2	2.910	7.446E+06	1.571E+04	1.527E+01	7.823E-04
21	1.0549	320.4	2.910	7.431E+06	1.568E+04	1.520E+01	7.795E-04
22	1.0501	320.4	2.909	7.399E+06	1.565E+04	1.522E+01	7.839E-04
23	1.0480	321.1	2.910	7.355E+06	1.557E+04	1.506E+01	7.774E-04
24	1.0473	320.8	2.910	7.365E+06	1.559E+04	1.503E+01	7.764E-04
RUN NO. 801273 K = .0102 CM MDOT = .0488 KG/M2S							
1	1.3141	317.9	2.923	9.298E+06	1.803E+04	1.942E+01	8.082E-04
2	1.3121	317.5	2.923	9.302E+06	1.804E+04	1.941E+01	8.086E-04
3	1.3024	318.7	2.923	9.182E+06	1.791E+04	1.936E+01	8.130E-04
4	1.2955	317.0	2.922	9.213E+06	1.795E+04	1.916E+01	8.079E-04
5	1.2500	318.3	2.923	8.830E+06	1.748E+04	1.846E+01	8.073E-04
6	1.2480	316.4	2.920	8.909E+06	1.756E+04	1.828E+01	7.987E-04
7	1.2321	320.2	2.923	8.629E+06	1.721E+04	1.815E+01	8.052E-04
8	1.1900	315.6	2.914	8.552E+06	1.708E+04	1.713E+01	7.814E-04
9	1.1873	322.3	2.923	8.232E+06	1.667E+04	1.726E+01	7.951E-04
10	1.1314	323.4	2.923	7.806E+06	1.611E+04	1.621E+01	7.833E-04
11	1.1128	315.8	2.914	7.989E+06	1.637E+04	1.564E+01	7.652E-04
12	1.0852	324.5	2.920	7.461E+06	1.565E+04	1.538E+01	7.730E-04
13	1.0515	325.9	2.917	7.194E+06	1.528E+04	1.476E+01	7.641E-04
14	1.0459	317.0	2.910	7.483E+06	1.566E+04	1.427E+01	7.382E-04
15	.9260	316.4	2.903	6.667E+06	1.455E+04	1.185E+01	6.883E-04
16	.8598	314.7	2.895	6.267E+06	1.399E+04	1.048E+01	6.514E-04
17	.7936	312.4	2.889	5.867E+06	1.344E+04	9.123E+00	6.112E-04
18	.7253	314.3	2.887	5.318E+06	1.269E+04	7.875E+00	5.765E-04
19	.6881	316.0	2.885	5.012E+06	1.224E+04	7.187E+00	5.536E-04
20	.6557	316.6	2.882	4.771E+06	1.192E+04	6.706E+00	5.406E-04
21	.6136	316.0	2.872	4.500E+06	1.153E+04	5.970E+00	5.101E-04
22	.5757	314.5	2.872	4.252E+06	1.121E+04	5.302E+00	4.829E-04
23	.5330	312.4	2.861	3.999E+06	1.084E+04	4.455E+00	4.343E-04
24	.4813	310.9	2.850	3.657E+06	1.038E+04	3.695E+00	3.955E-04
25	.4206	310.0	2.828	3.248E+06	9.761E+03	2.687E+00	3.233E-04

NSWC TR 79-153

TABLE A-4 SKIN FRICTION DATA LISTING

N	P0*10-5 (N/M2)	T0 (DFG.K)	M	RE (1/M)	RETH	TAUW (N/M2)	CF
RUN NO.	801244	K =	.0102 CM	MDOT =	.1465 KG/M2S		
1	4.0920	325.1	2.927	2.795E+07	4.823E+04	6.403E+01	8.586E-04
2	4.0686	324.3	2.927	2.789E+07	4.805E+04	6.280E+01	8.468E-04
3	3.6666	323.2	2.922	2.534E+07	4.491E+04	5.287E+01	7.876E-04
4	3.4970	324.9	2.924	2.394E+07	4.334E+04	4.935E+01	7.725E-04
5	3.3233	319.8	2.923	2.331E+07	4.261E+04	4.489E+01	7.387E-04
6	3.1764	315.5	2.922	2.274E+07	4.198E+04	4.116E+01	7.083E-04
7	3.0785	319.2	2.921	2.167E+07	4.062E+04	3.911E+01	6.936E-04
8	3.0420	320.2	2.920	2.133E+07	4.020E+04	3.840E+01	6.888E-04
9	2.5262	311.3	2.901	1.865E+07	3.686E+04	2.617E+01	5.566E-04
10	1.3438	317.7	2.896	9.654E+06	2.628E+04	4.933E+00	1.963E-04
11	1.2790	317.9	2.889	9.211E+06	2.577E+04	4.296E+00	1.787E-04
12	1.0452	325.3	2.888	7.282E+06	2.340E+04	1.794E+00	9.120E-05
13	1.0384	322.1	2.888	7.340E+06	2.361E+04	1.841E+00	9.422E-05
14	1.0377	320.9	2.888	7.376E+06	2.367E+04	1.676E+00	8.579E-05
15	1.0370	320.4	2.888	7.391E+06	2.372E+04	1.747E+00	8.946E-05
16	1.0356	320.6	2.888	7.375E+06	2.370E+04	1.794E+00	9.200E-05
17	1.0335	321.1	2.887	7.342E+06	2.364E+04	1.747E+00	8.974E-05
18	1.0328	324.2	2.887	7.236E+06	2.339E+04	1.676E+00	8.615E-05
19	1.0328	321.3	2.887	7.330E+06	2.362E+04	1.770E+00	9.102E-05
20	1.0315	321.7	2.887	7.309E+06	2.358E+04	1.723E+00	8.868E-05
21	.9956	320.9	2.881	7.102E+06	2.333E+04	1.322E+00	7.014E-05
22	.8625	318.5	2.871	6.255E+06	2.254E+04	5.900E-01	3.585E-05
23	.7439	319.8	2.867	5.376E+06	2.159E+04	1.889E-01	1.325E-05

NSWC TR 79-153

TABLE A-4 SKIN FRICTION DATA LISTING

N	PO#10-5 (N/M2)	TO (DFG.K)	M	PE (1/M)	RETH	TAUW (N/M2)	CF
RUN NO.	801274	K =	.0102 CM	MDOT =	.1465 KG/M2S		
1	2.0402	316.6	2.923	1.452E+07	3.208E+04	1.605E+01	4.302E-04
2	2.0395	316.0	2.923	1.456E+07	3.211E+04	1.588E+01	4.258E-04
3	2.0291	315.8	2.922	1.451E+07	3.204E+04	1.566E+01	4.216E-04
4	2.0264	316.2	2.923	1.445E+07	3.199E+04	1.570E+01	4.236E-04
5	2.0009	316.6	2.923	1.424E+07	3.175E+04	1.533E+01	4.192E-04
6	1.9747	315.8	2.921	1.412E+07	3.161E+04	1.480E+01	4.093E-04
7	1.9147	316.0	2.924	1.366E+07	3.113E+04	1.393E+01	3.980E-04
8	1.8554	316.4	2.919	1.325E+07	3.055E+04	1.263E+01	3.708E-04
9	1.8388	315.6	2.921	1.317E+07	3.051E+04	1.240E+01	3.680E-04
10	1.8306	316.0	2.918	1.310E+07	3.040E+04	1.229E+01	3.657E-04
11	1.7788	315.1	2.917	1.280E+07	3.006E+04	1.134E+01	3.469E-04
12	1.7754	315.6	2.920	1.272E+07	3.002E+04	1.149E+01	3.532E-04
13	1.7113	313.8	2.914	1.241E+07	2.965E+04	1.029E+01	3.264E-04
14	1.6761	316.6	2.916	1.198E+07	2.909E+04	9.782E+00	3.173E-04
15	1.6375	315.6	2.913	1.177E+07	2.885E+04	9.079E+00	3.007E-04
16	1.5782	318.9	2.910	1.119E+07	2.807E+04	8.246E+00	2.827E-04
17	1.5196	321.1	2.910	1.067E+07	2.740E+04	7.393E+00	2.632E-04
18	1.5155	318.9	2.912	1.074E+07	2.758E+04	7.330E+00	2.622E-04
19	1.5031	321.1	2.910	1.055E+07	2.728E+04	7.190E+00	2.588E-04
20	1.4638	318.7	2.907	1.041E+07	2.718E+04	6.588E+00	2.430E-04
21	1.3934	316.6	2.903	1.002E+07	2.678E+04	5.523E+00	2.133E-04
22	1.3845	317.7	2.907	9.890E+06	2.662E+04	5.400E+00	2.104E-04
23	1.3514	315.8	2.903	9.757E+06	2.652E+04	4.956E+00	1.973E-04
24	1.3383	318.1	2.906	9.547E+06	2.624E+04	4.902E+00	1.975E-04
25	1.2611	318.9	2.903	8.979E+06	2.556E+04	3.933E+00	1.677E-04
26	1.2507	315.1	2.898	9.089E+06	2.576E+04	3.635E+00	1.556E-04
27	1.2252	316.4	2.898	8.847E+06	2.546E+04	3.416E+00	1.493E-04
28	1.2155	316.0	2.896	8.800E+06	2.542E+04	3.346E+00	1.473E-04
29	1.2128	317.3	2.898	8.720E+06	2.529E+04	3.286E+00	1.451E-04
30	1.2011	317.7	2.898	8.619E+06	2.518E+04	3.220E+00	1.436E-04
31	1.1893	317.5	2.897	8.546E+06	2.510E+04	3.071E+00	1.382E-04
32	1.1887	318.7	2.900	8.484E+06	2.502E+04	3.128E+00	1.412E-04
33	1.1831	318.3	2.896	8.475E+06	2.498E+04	2.988E+00	1.351E-04
34	1.1694	319.1	2.897	8.342E+06	2.482E+04	2.868E+00	1.313E-04
35	1.1611	315.1	2.893	8.459E+06	2.507E+04	2.773E+00	1.274E-04
36	1.1549	319.6	2.898	8.214E+06	2.467E+04	2.741E+00	1.272E-04
37	1.1425	320.0	2.898	8.112E+06	2.455E+04	2.592E+00	1.216E-04
38	1.1025	320.9	2.898	7.795E+06	2.417E+04	2.231E+00	1.084E-04
39	1.1004	315.1	2.890	8.029E+06	2.460E+04	2.158E+00	1.044E-04
40	1.0983	319.8	2.896	7.813E+06	2.423E+04	2.212E+00	1.077E-04
41	1.0542	322.1	2.892	7.437E+06	2.371E+04	1.800E+00	9.103E-05
42	1.0535	320.2	2.893	7.493E+06	2.384E+04	1.721E+00	8.715E-05
43	1.0335	315.3	2.886	7.549E+06	2.406E+04	1.534E+00	7.873E-05
44	1.0190	320.4	2.890	7.255E+06	2.357E+04	1.451E+00	7.578E-05
45	.9908	316.0	2.884	7.220E+06	2.368E+04	1.271E+00	6.791E-05
46	.9818	321.7	2.890	6.946E+06	2.321E+04	1.223E+00	6.630E-05
47	.9598	324.0	2.892	6.713E+06	2.291E+04	1.185E+00	6.583E-05
48	.9563	322.1	2.888	6.762E+06	2.299E+04	1.059E+00	5.881E-05
49	.9177	323.0	2.885	6.472E+06	2.264E+04	8.428E-01	4.866E-05
50	.8874	315.6	2.875	6.510E+06	2.293E+04	6.814E-01	4.025E-05
51	.8591	324.0	2.880	6.048E+06	2.215E+04	5.704E-01	3.504E-05
52	.8529	316.6	2.875	6.227E+06	2.263E+04	5.672E-01	3.497E-05
53	.8432	324.2	2.877	5.940E+06	2.201E+04	4.850E-01	3.028E-05

NSWC TR 79-153

TABLE A-4 SKIN FRICTION DATA LISTING

N	P0*10-5 (N/M2)	T0 (DFG.K)	M	RE (1/M)	RETH	TAUW (N/M2)	CF
RUN NO. 802021 K = .0330 CM MDOT = 0.0000 KG/M2S							
1	.6826	313.2	2.922	4.941E+06	8.869E+03	1.815E+01	1.453E-03
2	.6605	314.3	2.927	4.744E 06	8.607E+03	1.776E+01	1.475E-03
3	.6095	314.7	2.917	4.392E+06	8.029E+03	1.641E+01	1.465E-03
4	.5674	314.3	2.909	4.114E+06	7.581E+03	1.537E+01	1.464E-03
5	.5268	312.8	2.899	3.866E+06	7.178E+03	1.436E+01	1.462E-03
6	.4964	311.9	2.896	3.666E+06	6.853E+03	1.357E+01	1.461E-03
7	.4599	312.2	2.893	3.396E+06	6.436E+03	1.275E+01	1.479E-03
8	.4302	313.6	2.892	3.158E+06	6.068E+03	1.209E+01	1.498E-03
9	.4027	313.8	2.888	2.960E+06	5.753E+03	1.147E+01	1.513E-03
10	.3758	311.5	2.875	2.811E+06	5.482E+03	1.072E+01	1.499E-03
11	.3496	308.2	2.866	2.669E+06	5.262E+03	1.018E+01	1.519E-03
12	.3234	306.1	2.856	2.507E+06	4.986E+03	9.517E+00	1.524E-03
13	.2972	305.5	2.853	2.315E+06	4.669E+03	8.880E+00	1.542E-03
14	.2765	308.4	2.851	2.125E+06	4.364E+03	8.447E+00	1.575E-03
15	.2551	309.6	2.846	1.955E+06	4.081E+03	7.972E+00	1.604E-03
RUN NO. 802031 K = .0330 CM MDOT = 0.0000 KG/M2S							
1	4.1699	303.6	2.936	3.140E+07	4.901E+04	1.357E+02	1.799E-03
2	4.1513	302.2	2.936	3.147E+07	4.909E+04	1.350E+02	1.797E-03
3	4.1272	303.2	2.935	3.114E+07	4.855E+04	1.338E+02	1.791E-03
4	4.1113	302.0	2.936	3.119E+07	4.848E+04	1.325E+02	1.781E-03
5	4.0417	301.1	2.934	3.084E+07	4.796E+04	1.302E+02	1.779E-03
6	3.9769	301.3	2.933	3.034E+07	4.734E+04	1.286E+02	1.783E-03
7	3.9107	301.7	2.934	2.975E+07	4.663E+04	1.269E+02	1.791E-03
8	3.8390	301.9	2.933	2.919E+07	4.581E+04	1.244E+02	1.787E-03
9	3.7894	302.4	2.932	2.874E+07	4.513E+04	1.225E+02	1.782E-03
10	3.7425	303.0	2.934	2.828E+07	4.469E+04	1.219E+02	1.798E-03
11	3.6880	303.2	2.933	2.785E+07	4.397E+04	1.195E+02	1.787E-03
12	3.6108	302.8	2.933	2.733E+07	4.331E+04	1.174E 02	1.793E-03
13	3.5515	303.2	2.932	2.684E+07	4.244E+04	1.146E+02	1.778E-03
14	3.4950	304.4	2.931	2.628E+07	4.172E+04	1.132E+02	1.783E-03
15	3.4315	304.6	2.929	2.580E+07	4.097E+04	1.108E+02	1.776E-03
16	3.3688	304.7	2.929	2.531E+07	4.033E+04	1.091E+02	1.780E-03
17	3.2971	305.3	2.931	2.468E+07	3.937E+04	1.062E+02	1.773E-03
18	3.2274	305.7	2.930	2.412E+07	3.872E+04	1.048E+02	1.786E-03
19	3.1571	306.5	2.931	2.349E+07	3.776E+04	1.020E+02	1.778E-03
20	3.1075	307.4	2.930	2.302E+07	3.704E+04	1.001E+02	1.773E-03
21	3.0578	308.0	2.930	2.260E+07	3.643E+04	9.853E+01	1.772E-03
22	2.9889	308.8	2.928	2.203E+07	3.574E+04	9.711E+01	1.784E-03
23	2.9227	309.4	2.927	2.149E+07	3.501E+04	9.526E+01	1.788E-03
24	2.8751	310.0	2.931	2.104E 07	3.429E+04	9.299E+01	1.780E-03
25	2.7400	310.0	2.927	2.009E+07	3.282E+04	8.830E+01	1.769E-03
26	2.6648	309.6	2.927	1.957E+07	3.211E+04	8.607E+01	1.773E-03
27	2.5897	309.8	2.924	1.904E+07	3.125E+04	8.337E+01	1.762E-03
28	2.4993	310.1	2.924	1.834E+07	3.020E+04	8.025E+01	1.757E-03
29	2.3959	310.9	2.925	1.750E+07	2.897E+04	7.675E+01	1.755E-03
30	2.3173	311.9	2.926	1.685E+07	2.807E+04	7.452E+01	1.762E-03
31	2.2546	313.2	2.922	1.632E+07	2.723E+04	7.234E+01	1.754E-03
32	2.1932	314.3	2.924	1.577E+07	2.635E+04	6.979E+01	1.742E-03
33	2.1043	314.9	2.919	1.513E+07	2.536E+04	6.695E+01	1.734E-03
34	1.8678	316.6	2.918	1.333E+07	2.262E+04	5.909E+01	1.723E-03

NSWC TR 79-153

TABLE A-4 SKIN FRICTION DATA LISTING

N	PO*10-5 (N/M2)	TO (DFG.K)	M	RE (1/M)	RETH	TAUW (N/M2)	CF
RIIN NO.	802071	K =	.0330 CM	MDOT =	0.0000 KG/M2S		
1	2.0767	318.1	2.937	1.457E+07	2.440E+04	6.436E+01	1.715E-03
2	2.0753	318.5	2.938	1.453E+07	2.444E+04	6.484E+01	1.729E-03
3	2.0739	317.5	2.937	1.459E+07	2.440E+04	6.409E+01	1.709E-03
4	2.0719	319.1	2.937	1.447E+07	2.427E+04	6.429E+01	1.717E-03
5	2.0636	319.2	2.937	1.440E+07	2.415E+04	6.792E+01	1.714E-03
6	2.0533	316.8	2.936	1.451E+07	2.423E+04	6.327E+01	1.703E-03
7	2.0064	315.8	2.934	1.425E+07	2.377E+04	6.139E+01	1.689E-03
8	1.9740	315.6	2.934	1.404E+07	2.350E+04	6.070E+01	1.696E-03
9	1.9305	315.6	2.932	1.374E+07	2.302E+04	5.916E+01	1.688E-03
10	1.8554	314.9	2.934	1.324E+07	2.213E+04	5.591E+01	1.663E-03
11	1.7851	314.3	2.930	1.280E+07	2.138E+04	5.341E+01	1.646E-03
12	1.7423	314.5	2.932	1.247E+07	2.095E+04	5.734E+01	1.655E-03
13	1.6803	314.5	2.929	1.205E+07	2.025E+04	5.016E+01	1.640E-03
14	1.6354	315.3	2.931	1.166E+07	1.969E+04	4.873E+01	1.641E-03
15	1.5741	315.8	2.930	1.121E+07	1.895E+04	4.659E+01	1.628E-03
16	1.5100	316.0	2.928	1.075E+07	1.823E+04	4.449E+01	1.618E-03
17	1.4520	317.0	2.929	1.029E+07	1.753E+04	4.270E+01	1.616E-03
18	1.4024	318.1	2.924	9.909E+06	1.691E+04	4.107E+01	1.603E-03
19	1.3514	319.6	2.924	9.481E+06	1.627E+04	3.958E+01	1.603E-03
20	1.2162	320.2	2.926	8.501E+06	1.475E+04	3.532E+01	1.592E-03
21	1.1811	320.2	2.925	8.262E+06	1.436E+04	3.420E+01	1.586E-03
22	1.1438	319.8	2.925	8.016E+06	1.397E+04	3.301E+01	1.580E-03
23	1.0942	319.2	2.920	7.706E 06	1.344E+04	3.138E+01	1.565E-03
24	1.0549	318.5	2.919	7.459E+06	1.309E+04	3.043E+01	1.573E-03
25	1.0377	318.1	2.925	7.328E+06	1.284E+04	2.949E+01	1.557E-03
26	1.0377	317.9	2.925	7.333E+06	1.282E+04	2.937E+01	1.551E-03
27	1.0377	317.7	2.925	7.340E+06	1.283E+04	2.937E+01	1.551E-03
28	1.0377	317.5	2.925	7.347E+06	1.284E+04	2.934E+01	1.549E-03
29	1.0370	323.0	2.921	7.174E+06	1.252E+04	2.907E+01	1.531E-03
30	1.0370	321.5	2.925	7.209E+06	1.262E+04	2.929E+01	1.547E-03
31	1.0370	321.1	2.925	7.223E+06	1.261E+04	2.912E+01	1.538E-03
32	1.0301	317.3	2.924	7.305E+06	1.277E+04	2.915E+01	1.548E-03
33	1.0170	317.9	2.920	7.206E+06	1.268E+04	2.922E+01	1.568E-03
34	.9784	317.3	2.918	6.960E+06	1.226E+04	2.788E+01	1.552E-03

NSWC TR 79-153

TABLE A-4 SKIN FRICTION DATA LISTING

N	P0*10-5 (N/M2)	T0 (DEG.K)	M	RE (1/M)	RETH	TAUW (N/M2)	CF
RUN NO. 802022 K = .0330 CM MDOT = .0146 KG/M2S							
1	.8943	321.7	2.931	6.192E+06	1.169E+04	1.957E+01	1.204F-03
2	.4784	321.9	2.930	6.079E+06	1.152F+04	1.916E+01	1.200F-03
3	.8708	324.3	2.935	5.944E+06	1.134E+04	1.901E+01	1.206F-03
4	.8639	322.1	2.930	5.975E+06	1.136E+04	1.879E+01	1.196E-03
5	.8446	324.3	2.936	5.762E+06	1.106E+04	1.831E+01	1.198F-03
6	.8439	322.3	2.928	5.836E+06	1.116E+04	1.835E+01	1.194E-03
7	.8308	322.5	2.927	5.744E+06	1.100E+04	1.794E+01	1.185E-03
8	.8136	322.6	2.925	5.625E+06	1.083E+04	1.759E+01	1.184E-03
9	.8122	324.3	2.934	5.546E+06	1.074E+04	1.756E+01	1.194E-03
10	.8005	322.8	2.926	5.528E+06	1.068E+04	1.721E+01	1.179F-03
11	.7846	322.8	2.925	5.422E+06	1.051E+04	1.677E+01	1.170E-03
12	.7812	324.2	2.932	5.344E+06	1.041E+04	1.668E+01	1.177F-03
13	.7681	323.0	2.923	5.308E+06	1.034E+04	1.641E+01	1.169E-03
14	.7570	324.0	2.931	5.188E+06	1.018E+04	1.613E+01	1.173F-03
15	.7398	323.4	2.922	5.107E+06	1.003E+04	1.570E+01	1.160E-03
16	.7343	323.8	2.929	5.040E+06	9.941E+03	1.550E+01	1.160E-03
17	.7157	322.8	2.920	4.958E+06	9.797E+03	1.508E+01	1.149E-03
18	.6943	322.1	2.918	4.832E+06	9.603E+03	1.456E+01	1.142E-03
19	.6729	321.1	2.915	4.711E+06	9.414E+03	1.403E+01	1.133F-03
20	.6550	320.4	2.912	4.608E+06	9.248E+03	1.357E+01	1.123F-03
21	.6364	319.8	2.910	4.495E+06	9.067E+03	1.309E+01	1.113E-03
22	.6260	324.0	2.922	4.310E+06	8.829E+03	1.299E+01	1.133F-03
23	.6123	318.9	2.907	4.351E+06	8.846E+03	1.254E+01	1.105E-03
24	.5874	318.3	2.906	4.186E+06	8.592E+03	1.192E+01	1.094E-03
25	.5840	323.6	2.924	4.023E+06	8.387E+03	1.193E+01	1.118E-03
26	.5530	317.3	2.898	3.974E+06	8.256E+03	1.112E+01	1.077E-03
27	.5502	323.2	2.923	3.798E+06	8.044E+03	1.116E+01	1.109F-03
28	.5295	316.8	2.896	3.820E+06	8.015E+03	1.055E+01	1.066E-03
29	.5081	316.4	2.893	3.680E+06	7.798E+03	1.008E+01	1.058E-03
30	.4881	316.0	2.890	3.546E+06	7.582E+03	9.574E+00	1.044E-03
31	.4592	315.6	2.883	3.354E+06	7.281E+03	8.956E+00	1.032E-03
32	.4289	315.1	2.874	3.156E+06	6.973E+03	8.343E+00	1.022E-03
33	.3971	314.3	2.870	2.939E+06	6.641E+03	7.674E+00	1.011E-03
34	.3730	313.0	2.861	2.790E+06	6.400E+03	7.140E+00	9.950E-04
35	.3420	311.7	2.854	2.585E+06	6.070E+03	6.441E+00	9.728E-04
36	.3172	310.0	2.841	2.434E+06	5.823E+03	5.921E+00	9.540E-04
37	.2910	308.2	2.833	2.260E+06	5.553E+03	5.394E+00	9.413E-04
38	.2627	307.6	2.816	2.064E+06	5.234E+03	4.860E+00	9.271E-04
RUN NO. 802032 K = .0330 CM MDOT = .0146 KG/M2S							
1	4.1624	311.1	2.935	3.022E+07	4.866E+04	1.335E+02	1.772F-03
2	4.1562	310.3	2.935	3.029E+07	4.866E+04	1.327E+02	1.764E-03
3	4.1107	309.8	2.934	3.006E+07	4.826E+04	1.304E+02	1.757E-03
4	3.9934	308.4	2.932	2.943E+07	4.723E+04	1.265E+02	1.744E-03
5	3.8452	308.2	2.932	2.835E+07	4.588E+04	1.223E+02	1.753E-03
6	3.7376	309.0	2.934	2.744E+07	4.462E+04	1.187E+02	1.753F-03
7	3.6363	309.6	2.930	2.667E+07	4.347E+04	1.154E+02	1.746E-03
8	3.5453	309.8	2.931	2.597E+07	4.248E+04	1.123E+02	1.744E-03
9	3.4246	309.4	2.929	2.515E+07	4.137E+04	1.087E+02	1.745E-03
10	3.3116	308.4	2.924	2.450E+07	4.021E+04	1.042E+02	1.722E-03
11	3.1881	307.1	2.929	2.368E+07	3.893E+04	9.902E+01	1.707E-03
12	2.0808	314.9	2.935	1.484E+07	2.546E+04	5.917E+01	1.571E-03
13	2.0801	314.1	2.935	1.489E+07	2.556E+04	5.930E+01	1.575E-03

NSWC TR 79-153

TABLE A-4 SKIN FRICTION DATA LISTING

N	PO*10-5 (N/M2)	TO (DFG.K)	M	RE (1/M)	RETH	TAUW (N/M2)	CF
RUN NO.	802074	K =	.0330 CM	MDOT =	.0146 KG/M2S		
1	2.0801	315.6	2.935	1.478E+07	2.542E+04	5.939E+01	1.577E-03
2	2.0788	316.4	2.935	1.472E+07	2.530E+04	5.915E+01	1.571E-03
3	2.0546	316.8	2.933	1.454E+07	2.505E+04	5.860E+01	1.572E-03
4	2.0153	316.6	2.932	1.428E+07	2.458E+04	5.694E+01	1.557E-03
5	1.9864	316.8	2.931	1.407E 07	2.434E+04	5.647E+01	1.564E-03
6	1.9560	317.3	2.930	1.383E+07	2.387E+04	5.498E+01	1.546E-03
7	1.9154	317.0	2.929	1.357E+07	2.344E+04	5.346E+01	1.533E-03
8	1.8657	317.0	2.931	1.320E+07	2.288E+04	5.170E+01	1.526E-03
9	1.8292	317.3	2.930	1.293E+07	2.253E+04	5.096E+01	1.532E-03
10	1.7982	317.7	2.930	1.269E+07	2.207E+04	4.944E+01	1.512E-03
11	1.7664	317.9	2.930	1.245E+07	2.175E+04	4.860E+01	1.513E-03
12	1.7375	318.3	2.929	1.223E+07	2.137E+04	4.748E+01	1.502E-03
13	1.7168	318.5	2.929	1.208E+07	2.113E+04	4.676E+01	1.497E-03
14	1.6927	318.7	2.928	1.190E+07	2.086E+04	4.604E+01	1.494E-03
15	1.6644	318.5	2.928	1.172E+07	2.053E+04	4.485E+01	1.479E-03
16	1.5244	317.9	2.924	1.078E+07	1.905E+04	4.033E+01	1.448E-03
17	1.4279	317.0	2.918	1.018E+07	1.805E+04	3.711E+01	1.415E-03
18	1.3776	316.6	2.920	9.825E+06	1.751E+04	3.542E+01	1.402E-03
19	1.3369	316.6	2.918	9.542E+06	1.701E+04	3.383E+01	1.379E-03
20	1.2755	316.0	2.918	9.130E+06	1.641E+04	3.214E+01	1.372E-03
21	1.2755	316.0	2.918	9.130E+06	1.641E+04	3.214E+01	1.372E-03
22	1.2293	315.6	2.916	8.824E+06	1.596E+04	3.095E+01	1.369E-03
23	1.2293	315.6	2.916	8.824E+06	1.596E+04	3.095E+01	1.369E-03
24	1.1238	315.1	2.916	8.088E+06	1.479E+04	2.755E+01	1.333E-03
25	1.0921	315.3	2.916	7.852E+06	1.443E+04	2.661E+01	1.325E-03
26	1.0452	315.5	2.912	7.527E+06	1.394E+04	2.544E+01	1.319E-03
27	1.0356	316.4	2.920	7.390E+06	1.370E+04	2.472E+01	1.303E-03
28	1.0356	316.4	2.920	7.390E 06	1.372E+04	2.482E+01	1.308E-03
29	1.0315	323.8	2.921	7.112E+06	1.324E+04	2.445E+01	1.294E-03
30	1.0266	324.0	2.921	7.073E 06	1.320E+04	2.442E+01	1.299E-03
31	1.0156	315.6	2.911	7.309E 06	1.359E+04	2.447E+01	1.305E-03
32	.9729	313.9	2.909	7.066E+06	1.310E+04	2.261E+01	1.256E-03
33	.9660	324.9	2.921	6.624E+06	1.249E+04	2.256E+01	1.276E-03
34	.9439	324.9	2.920	6.476E+06	1.230E+04	2.219E+01	1.283E-03

NSWC TR 79-153

TABLE A-4 SKIN FRICTION DATA LISTING

N	PO*10-5 (N/M2)	TO (DFG.K)	M	RE (1/M)	RETH	TAUW (N/M2)	CF
RUN NO.	802023	K =	.0330 CM	MDOT =	.0488 KG/M2S		
1	1.1721	320.2	2.931	8.172E+06	1.718E+04	2.002E+01	9.403E-04
2	1.1404	319.8	2.931	7.965E+06	1.688E+04	1.918E+01	9.259E-04
3	1.1183	317.7	2.932	7.881E+06	1.674E+04	1.835E+01	9.041E-04
4	1.1183	319.4	2.929	7.834E+06	1.668E+04	1.864E+01	9.159E-04
5	1.1011	319.2	2.928	7.723E+06	1.651E+04	1.815E+01	9.050E-04
6	1.0859	319.1	2.927	7.628E+06	1.635E+04	1.768E+01	8.930E-04
7	1.0804	317.7	2.932	7.614E+06	1.635E+04	1.736E+01	8.855E-04
8	1.0708	318.9	2.927	7.526E 06	1.622E+04	1.732E+01	8.879E-04
9	1.0549	318.9	2.926	7.420E 06	1.605E+04	1.692E+01	8.790E-04
10	1.0384	318.7	2.925	7.315E+06	1.589E+04	1.646E+01	8.679E-04
11	1.0370	317.2	2.928	7.343E+06	1.593E+04	1.624E+01	8.604E-04
12	1.0239	317.5	2.926	7.245E+06	1.578E+04	1.592E+01	8.525E-04
13	1.0211	318.7	2.923	7.198E+06	1.571E+04	1.598E+01	8.559E-04
14	1.0115	318.7	2.926	7.121E+06	1.559E+04	1.567E 01	8.490E-04
15	1.0004	318.5	2.922	7.062E+06	1.552E+04	1.555E+01	8.497E-04
16	.9942	320.4	2.926	6.945E+06	1.533E+04	1.526E+01	8.414E-04
17	.9729	318.3	2.920	6.884E+06	1.524E+04	1.481E+01	8.300E-04
18	.9446	318.3	2.918	6.690E+06	1.494E+04	1.407E 01	8.111E-04
19	.9129	318.3	2.917	6.468E+06	1.462E+04	1.334E+01	7.954E-04
20	.8908	318.3	2.915	6.319E+06	1.439E+04	1.275E+01	7.774E-04
21	.8591	318.3	2.911	6.108E+06	1.407E+04	1.204E+01	7.585E-04
22	.8350	318.5	2.909	5.936E+06	1.380E+04	1.142E+01	7.395E-04
23	.8115	318.7	2.907	5.771E+06	1.355E+04	1.085E+01	7.213E-04
24	.7826	318.9	2.906	5.564E+06	1.326E+04	1.028E+01	7.078E-04
25	.7605	319.1	2.903	5.409E+06	1.303E+04	9.784E+00	6.921E-04
26	.7281	319.2	2.900	5.183E+06	1.269E+04	9.119E+00	6.719E-04
27	.6922	319.2	2.895	4.941E+06	1.233E+04	8.326E+00	6.427E-04
28	.6743	319.4	2.895	4.807E+06	1.213E+04	7.940E+00	6.294E-04
29	.6509	319.6	2.890	4.649E+06	1.189E+04	7.482E+00	6.119E-04
30	.6240	319.4	2.887	4.469E+06	1.163E+04	6.970E+00	5.930E-04
31	.6047	319.2	2.882	4.345E+06	1.144E+04	6.543E+00	5.721E-04
32	.5840	319.2	2.880	4.201E+06	1.124E+04	6.201E+00	5.605E-04
33	.5564	319.2	2.874	4.014E+06	1.096E+04	5.679E+00	5.363E-04
34	.5288	319.2	2.874	3.815E+06	1.068E+04	5.198E+00	5.164E-04
35	.4985	319.2	2.864	3.617E+06	1.037E+04	4.642E+00	4.850E-04
36	.4702	319.1	2.862	3.419E+06	1.009E+04	4.154E+00	4.593E-04
37	.4406	318.7	2.848	3.232E+06	9.796E+03	3.669E+00	4.281E-04
38	.4116	316.8	2.842	3.056E+06	9.566E+03	3.242E+00	4.030E-04
39	.3820	315.1	2.836	2.867E+06	9.304E+03	2.733E+00	3.644E-04
40	.3489	313.2	2.822	2.662E 06	9.013E+03	2.272E+00	3.279E-04
RUN NO.	802033	K =	.0330 CM	MDOT =	.0488 KG/M2S		
1	4.0562	310.1	2.933	2.962E+07	4.984E+04	1.201E+02	1.632E-03
2	4.0389	310.1	2.933	2.950E+07	4.971E+04	1.197E+02	1.634E-03
3	3.9886	310.1	2.933	2.913E+07	4.916E+04	1.178E+02	1.629E-03
4	3.9686	310.3	2.933	2.896E+07	4.901E+04	1.177E+02	1.635E-03
5	3.9493	310.5	2.933	2.879E+07	4.865E+04	1.164E+02	1.624E-03
6	3.9321	310.5	2.932	2.867E+07	4.857E+04	1.164E+02	1.631E-03
7	3.9162	310.5	2.933	2.855E+07	4.835E+04	1.155E+02	1.626E-03
8	3.8955	310.5	2.932	2.841E+07	4.817E+04	1.150E+02	1.626E-03
9	3.8438	310.1	2.932	2.808E+07	4.754E+04	1.123E+02	1.610E-03

NSWC TR 79-153

TABLE A-4 SKIN FRICTION DATA LISTING

N	PO*10-5 (N/M2)	TO (DEG.K)	M	RE (1/M)	RETH	TAUW (N/M2)	CF
RUN NO. 802077 K = .0330 CM MDOT = .0488 KG/M2S							
1	2.0733	318.1	2.931	1.459E+07	2.734E+04	5.047E+01	1.341E-03
2	2.0664	317.9	2.931	1.456E+07	2.731E+04	5.035E+01	1.341E-03
3	2.0477	318.1	2.930	1.443E+07	2.710E+04	4.977E+01	1.337E-03
4	1.9919	317.0	2.928	1.412E+07	2.656E+04	4.758E+01	1.312E-03
5	1.8892	314.5	2.923	1.358E+07	2.567E+04	4.405E+01	1.275E-03
6	1.7940	313.4	2.924	1.296E+07	2.467E+04	4.054E+01	1.237E-03
7	1.7271	315.1	2.926	1.236E+07	2.381E+04	3.857E+01	1.225E-03
8	1.6609	317.9	2.921	1.176E+07	2.282E+04	3.631E+01	1.194E-03
9	1.5996	319.2	2.923	1.125E+07	2.204E+04	3.434E+01	1.174E-03
10	1.5362	320.8	2.923	1.073E+07	2.126E+04	3.242E+01	1.154E-03
11	1.4975	322.3	2.923	1.039E+07	2.083E+04	3.180E+01	1.161E-03
12	1.2997	322.6	2.915	9.033E+06	1.866E+04	2.548E+01	1.065E-03
13	1.2507	322.1	2.909	8.745E+06	1.813E+04	2.368E+01	1.024E-03
14	1.2066	321.7	2.910	8.446E+06	1.772E+04	2.256E+01	1.012E-03
15	1.1673	321.9	2.909	8.167E+06	1.727E+04	2.129E+01	9.865E-04
16	1.1328	321.9	2.911	7.919E+06	1.693E+04	2.047E+01	9.787E-04
17	1.1025	321.9	2.909	7.714E+06	1.663E+04	1.975E+01	9.688E-04
18	1.0735	321.7	2.910	7.514E+06	1.632E+04	1.881E+01	9.480E-04
19	1.0377	321.3	2.908	7.285E+06	1.600E+04	1.801E+01	9.373E-04
20	1.0377	319.4	2.912	7.332E+06	1.602E+04	1.751E+01	9.147E-04
21	1.0349	319.1	2.913	7.324E+06	1.605E+04	1.766E+01	9.253E-04
22	1.0321	319.1	2.912	7.306E+06	1.600E+04	1.746E+01	9.170E-04
23	1.0163	318.7	2.909	7.219E+06	1.587E+04	1.711E+01	9.102E-04
24	1.0115	317.5	2.912	7.211E+06	1.578E+04	1.637E+01	8.768E-04
25	1.0004	321.1	2.905	7.042E+06	1.560E+04	1.691E+01	9.107E-04
26	.9935	318.3	2.909	7.068E+06	1.564E+04	1.642E+01	8.935E-04
RUN NO. 802024 K = .0330 CM MDOT = .1465 KG/M2S							
1	2.0181	309.6	2.935	1.476E+07	3.419E+04	2.384E+01	6.525E-04
2	2.0181	309.4	2.935	1.478E+07	3.421E+04	2.381E+01	6.517E-04
3	2.0098	310.3	2.936	1.464E+07	3.402E+04	2.365E+01	6.504E-04
4	2.0050	310.0	2.935	1.464E+07	3.403E+04	2.360E+01	6.501E-04
5	1.9898	310.9	2.935	1.446E+07	3.376E+04	2.316E+01	6.430E-04
6	1.9629	311.5	2.935	1.423E+07	3.347E+04	2.271E+01	6.389E-04
7	1.9429	311.1	2.932	1.413E+07	3.333E+04	2.230E+01	6.324E-04
8	1.9395	312.6	2.934	1.399E+07	3.309E+04	2.207E+01	6.278E-04
9	1.9147	313.6	2.933	1.375E+07	3.273E+04	2.138E+01	6.158E-04
10	1.8823	314.3	2.932	1.348E+07	3.235E+04	2.069E+01	6.056E-04
11	1.8823	313.9	2.930	1.352E+07	3.243E+04	2.089E+01	6.107E-04
12	1.8340	315.3	2.931	1.308E+07	3.176E+04	1.936E+01	5.813E-04
13	1.7975	316.6	2.931	1.274E+07	3.129E+04	1.859E+01	5.693E-04
14	1.7919	318.1	2.929	1.263E+07	3.110E+04	1.861E+01	5.707E-04
15	1.7623	318.3	2.930	1.240E+07	3.076E+04	1.764E+01	5.508E-04
16	1.7533	318.1	2.927	1.237E+07	3.068E+04	1.736E+01	5.431E-04
17	1.7133	318.3	2.926	1.208E+07	3.028E+04	1.642E+01	5.254E-04
18	1.7037	319.2	2.927	1.195E+07	3.013E+04	1.635E+01	5.267E-04
19	1.6775	317.7	2.923	1.188E+07	2.997E+04	1.540E+01	5.023E-04
20	1.6313	320.0	2.926	1.141E+07	2.934E+04	1.444E+01	4.855E-04
21	1.6299	317.0	2.920	1.160E+07	2.959E+04	1.426E+01	4.775E-04
22	1.5658	315.6	2.917	1.123E+07	2.908E+04	1.259E+01	4.377E-04
23	1.5196	314.9	2.915	1.095E+07	2.871E+04	1.148E+01	4.105E-04
24	1.4638	314.5	2.914	1.057E+07	2.822E+04	1.025E+01	3.801E-04
25	1.4279	314.3	2.911	1.034E+07	2.790E+04	9.527E+00	3.612E-04

NSWC TR 79-153

TABLE A-4 SKIN FRICTION DATA LISTING

N	PO*10-5 (N/M2)	TO (DEG.K)	M	RE (1/M)	RETH	TAUW (N/M2)	CF
RUN NO. 802024 K = .0330 CM MDOT = .1465 KG/M2S							
26	1.3727	313.6	2.909	9.985E+06	2.742E+04	8.144E+00	3.208E-04
27	1.2852	319.8	2.906	9.094E+06	2.607E+04	6.542E+00	2.745E-04
28	1.2852	319.1	2.906	9.127E+06	2.613E+04	6.502E+00	2.728E-04
29	1.2824	318.5	2.906	9.131E+06	2.617E+04	6.505E+00	2.736E-04
30	1.2817	312.8	2.905	9.378E+06	2.668E+04	6.588E+00	2.770E-04
31	1.2721	321.3	2.906	8.938E+06	2.583E+04	6.339E+00	2.688E-04
32	1.2459	322.3	2.906	8.717E+06	2.554E+04	5.935E+00	2.569E-04
33	1.2335	312.8	2.900	9.047E+06	2.624E+04	5.765E+00	2.509E-04
34	1.1914	312.6	2.898	8.760E+06	2.588E+04	5.068E+00	2.278E-04
35	1.1425	312.4	2.897	8.411E+06	2.548E+04	4.397E+00	2.059E-04
36	1.0887	312.1	2.890	8.059E+06	2.504E+04	3.639E+00	1.778E-04
37	1.0349	312.2	2.889	7.656E+06	2.456E+04	2.870E+00	1.475E-04
38	.9756	312.1	2.879	7.262E+06	2.408E+04	2.386E+00	1.298E-04
39	.9046	310.7	2.873	6.797E+06	2.360E+04	1.736E+00	1.007E-04
40	.8336	311.3	2.871	6.254E+06	2.300E+04	1.241E+00	7.802E-05
41	.7915	312.6	2.866	5.918E+06	2.257E+04	1.047E+00	6.898E-05
42	.7660	313.8	2.865	5.698E+06	2.230E+04	9.453E-01	6.435E-05
RUN NO. 802034 K = .0330 CM MDOT = .1465 KG/M2S							
1	3.3660	328.1	2.924	2.272E+07	4.520E+04	6.703E+01	1.090E-03
2	3.3488	326.2	2.924	2.280E+07	4.534E+04	6.650E+01	1.087E-03
3	3.2943	320.4	2.923	2.304E+07	4.570E+04	6.436E+01	1.068E-03
4	3.2647	318.7	2.923	2.301E+07	4.575E+04	6.374E+01	1.068E-03
5	3.1930	320.2	2.921	2.238E+07	4.480E+04	6.150E+01	1.052E-03
6	3.0240	318.7	2.916	2.140E+07	4.325E+04	5.549E+01	9.978E-04
7	2.8275	316.6	2.913	2.024E+07	4.150E+04	4.877E+01	9.351E-04
8	2.6772	319.6	2.911	1.891E+07	3.977E+04	4.533E+01	9.170E-04
9	2.0477	317.2	2.913	1.462E+07	3.367E+04	2.560E+01	6.776E-04
10	2.0408	316.6	2.912	1.461E+07	3.368E+04	2.550E+01	6.772E-04
11	2.0036	315.5	2.911	1.443E+07	3.345E+04	2.450E+01	6.622E-04
12	1.9891	314.9	2.911	1.437E+07	3.337E+04	2.407E+01	6.552E-04
13	1.9636	314.5	2.910	1.421E+07	3.313E+04	2.321E+01	6.396E-04
14	1.9285	323.2	2.902	1.346E+07	3.194E+04	2.216E+01	6.458E-04
15	1.8409	323.4	2.907	1.281E+07	3.114E+04	2.107E+01	6.174E-04
16	1.7313	325.5	2.903	1.196E+07	2.989E+04	1.830E+01	5.686E-04
17	1.6134	325.3	2.894	1.121E+07	2.881E+04	1.549E+01	5.124E-04

NSWC TR 79-153

TABLE A-4 SKIN FRICTION DATA LISTING

N	PO*10-5 (N/M2)	T0 (DFG.K)	M	RE (1/M)	RETH	TAUW (N/M2)	CF
RUN NO.	802078	K =	.0330 CM	MDOT =	.1465 KG/M2S		
1	1.9485	315.6	2.918	1.397E 07	3.286E+04	2.272E+01	6.352E-04
2	1.9478	315.6	2.918	1.396E+07	3.295E+04	2.327E+01	6.509E-04
3	1.9471	315.6	2.918	1.396E+07	3.292E+04	2.312E+01	6.468E-04
4	1.9423	316.0	2.918	1.390E+07	3.279E+04	2.279E+01	6.391E-04
5	1.9347	316.4	2.918	1.382E+07	3.267E+04	2.257E+01	6.353E-04
6	1.9264	316.6	2.918	1.375E+07	3.259E+04	2.247E+01	6.350E-04
7	1.9250	316.6	2.918	1.374E+07	3.259E+04	2.252E+01	6.371E-04
8	1.8919	317.0	2.920	1.347E+07	3.220E+04	2.141E+01	6.174E-04
9	1.8919	315.8	2.916	1.357E+07	3.231E+04	2.139E+01	6.144E-04
10	1.8161	318.9	2.923	1.279E+07	3.125E+04	1.933E+01	5.822E-04
11	1.8161	313.9	2.912	1.317E+07	3.163E+04	1.862E+01	5.557E-04
12	1.7423	313.2	2.913	1.267E+07	3.109E+04	1.729E+01	5.382E-04
13	1.7189	318.9	2.922	1.212E+07	3.035E+04	1.707E+01	5.424E-04
14	1.6954	313.0	2.911	1.236E+07	3.057E+04	1.564E+01	4.993E-04
15	1.6458	313.0	2.911	1.199E+07	3.012E+04	1.458E+01	4.797E-04
16	1.6306	319.1	2.918	1.151E+07	2.941E+04	1.443E+01	4.819E-04
17	1.6017	313.6	2.910	1.164E+07	2.962E+04	1.345E+01	4.545E-04
18	1.5493	319.4	2.915	1.093E+07	2.860E+04	1.255E+01	4.399E-04
19	1.5417	314.9	2.908	1.115E+07	2.893E+04	1.217E+01	4.263E-04
20	1.4955	315.8	2.904	1.079E+07	2.836E+04	1.096E+01	3.946E-04
21	1.4507	319.2	2.911	1.027E+07	2.777E+04	1.076E+01	4.016E-04
22	1.4369	316.8	2.905	1.032E+07	2.779E+04	1.006E+01	3.772E-04
23	1.3610	317.7	2.903	9.742E+06	2.699E+04	8.403E+00	3.321E-04
24	1.3086	319.8	2.911	9.239E+06	2.641E+04	7.650E+00	3.164E-04
25	1.2900	317.5	2.898	9.264E+06	2.632E+04	6.821E+00	2.833E-04
26	1.2342	320.0	2.907	8.721E+06	2.572E+04	6.218E+00	2.720E-04
27	1.1514	320.0	2.907	8.138E+06	2.501E+04	4.862E+00	2.279E-04
28	1.1245	318.7	2.894	8.051E+06	2.482E+04	4.284E+00	2.034E-04
29	1.0756	318.1	2.892	7.731E+06	2.447E+04	3.707E+00	1.836E-04
30	1.0687	318.1	2.892	7.678E+06	2.443E+04	3.681E+00	1.837E-04
31	1.0604	318.3	2.891	7.616E+06	2.434E+04	3.556E+00	1.787E-04
32	1.0521	318.5	2.903	7.503E+06	2.433E+04	3.656E+00	1.869E-04
33	1.0356	320.6	2.891	7.360E+06	2.398E+04	3.405E+00	1.752E-04
34	1.0356	320.6	2.891	7.362E+06	2.399E+04	3.455E+00	1.777E-04
35	1.0342	320.6	2.891	7.351E+06	2.398E+04	3.430E+00	1.767E-04
36	1.0321	320.4	2.890	7.349E+06	2.395E+04	3.280E+00	1.690E-04
37	.9846	318.7	2.886	7.080E+06	2.370E+04	2.803E+00	1.510E-04
38	.9839	319.4	2.896	7.013E+06	2.368E+04	2.827E+00	1.537E-04
39	.9398	317.7	2.883	6.796E+06	2.342E+04	2.375E+00	1.338E-04
40	.9136	317.9	2.880	6.613E+06	2.319E+04	2.124E+00	1.227E-04
41	.9087	320.4	2.892	6.463E+06	2.300E+04	2.024E+00	1.187E-04
42	.8756	317.2	2.874	6.379E+06	2.295E+04	1.873E+00	1.124E-04
43	.8391	316.4	2.873	6.139E+06	2.272E+04	1.622E+00	1.014E-04
44	.8143	324.0	2.890	5.702E+06	2.201E+04	1.220E+00	7.974E-05
45	.7991	315.5	2.871	5.878E+06	2.246E+04	1.245E+00	8.164E-05
46	.7653	315.1	2.867	5.651E+06	2.225E+04	1.195E+00	8.157E-05
47	.7315	314.9	2.865	5.412E+06	2.201E+04	1.070E+00	7.625E-05
48	.6929	314.7	2.876	5.102E+06	2.178E+04	9.188E-01	6.976E-05

NSWC TR 79-153

TABLE A-4 SKIN FRICTION DATA LISTING

N	PO*10-5 (N/M2)	TO (DEG.K)	M	RE (1/M)	RETH	TAUW (N/M2)	CF
RUN NO. 822221 K = .1245 CM MDOT = 0.0000 KG/M2S							
1	.5764	315.1	2.894	4.197E+06	8.829E+03	2.227E+01	2.063F-03
2	.5674	311.5	2.902	4.184E+06	8.851E+03	2.204E+01	2.088E-03
3	.5543	311.5	2.900	4.091E+06	8.665E+03	2.149E+01	2.081F-03
4	.5488	315.1	2.897	3.990E+06	8.450E+03	2.121E+01	2.068E-03
5	.5364	311.5	2.900	3.960E+06	8.441E+03	2.094E+01	2.095F-03
6	.5281	315.6	2.899	3.825E+06	8.162E+03	2.050E+01	2.091F-03
7	.5137	311.9	2.901	3.784E+06	8.093E+03	1.996E+01	2.087F-03
8	.5109	316.2	2.897	3.694E+06	7.911E+03	1.985E+01	2.080F-03
9	.4916	317.0	2.894	3.548E+06	7.652E+03	1.927E+01	2.092E-03
10	.4799	311.9	2.896	3.544E+06	7.625E+03	1.867E+01	2.081E-03
11	.4640	317.0	2.892	3.352E+06	7.250E+03	1.806E+01	2.075F-03
12	.4357	311.9	2.890	3.228E+06	7.006E+03	1.696E+01	2.072F-03
13	.4206	312.6	2.875	3.129E+06	6.735E+03	1.612E+01	2.015E-03
14	.4033	311.3	2.885	3.003E+06	6.543E+03	1.561E+01	2.051F-03
15	.3758	309.4	2.875	2.840E+06	6.166E+03	1.433E+01	2.004E-03
16	.3675	311.3	2.882	2.741E+06	6.029E+03	1.423E+01	2.048E-03
17	.3440	313.4	2.872	2.554E+06	5.621E+03	1.319E+01	2.011E-03
18	.3282	311.3	2.880	2.451E+06	5.441E+03	1.264E+01	2.033E-03
19	.3103	310.3	2.863	2.348E+06	5.190E+03	1.183E+01	1.985E-03
20	.2910	311.1	2.875	2.180E+06	4.901E+03	1.123E+01	2.029F-03
21	.2772	308.2	2.858	2.125E+06	4.747E+03	1.060E+01	1.983E-03
22	.2710	311.3	2.876	2.028E+06	4.592E+03	1.043E+01	2.026E-03
23	.2592	311.5	2.874	1.940E+06	4.414E+03	9.987E+00	2.024E-03
24	.2586	312.1	2.857	1.947E+06	4.395E+03	9.909E+00	1.985E-03
25	.2379	311.7	2.850	1.801E+06	4.076E+03	9.025E+00	1.954E-03
26	.2365	311.1	2.866	1.780E+06	4.076E+03	9.097E+00	2.007E-03
27	.2179	310.7	2.864	1.645E+06	3.801E+03	8.402E+00	2.009E-03
28	.2130	307.8	2.839	1.653E+06	3.765E+03	8.092E+00	1.938E-03
29	.2055	310.5	2.857	1.559E+06	3.624E+03	7.974E+00	2.009E-03
RUN NO. 822225 K = .1245 CM MDOT = 0.0000 KG/M2S							
1	4.1403	313.8	2.922	2.989E+07	5.620E+04	1.893E+02	2.498E-03
2	4.1341	313.6	2.922	2.987E+07	5.626E+04	1.895E+02	2.505E-03
3	4.1279	313.6	2.922	2.983E+07	5.612E+04	1.888E+02	2.500E-03
4	4.1127	313.6	2.922	2.972E+07	5.588E+04	1.879E+02	2.496E-03
5	4.0714	313.0	2.921	2.951E+07	5.558E+04	1.864E+02	2.500E-03
6	4.0141	312.4	2.921	2.918E+07	5.499E+04	1.837E+02	2.498E-03
7	3.9293	312.6	2.919	2.856E+07	5.404E+04	1.805E+02	2.505E-03
8	3.8583	313.2	2.918	2.798E+07	5.284E+04	1.762E+02	2.488E-03
9	3.7763	313.0	2.919	2.740E+07	5.188E+04	1.725E+02	2.491E-03
10	3.6411	313.0	2.918	2.644E+07	5.017E+04	1.661E+02	2.484E-03
11	3.5039	312.8	2.917	2.548E+07	4.835E+04	1.590E+02	2.468E-03
12	3.3881	313.4	2.914	2.461E+07	4.669E+04	1.531E+02	2.453E-03
13	3.3081	314.5	2.918	2.384E+07	4.565E+04	1.505E+02	2.478E-03
14	3.2419	316.0	2.917	2.322E+07	4.460E+04	1.478E+02	2.481E-03
15	3.1861	317.3	2.917	2.267E+07	4.371E+04	1.455E+02	2.486E-03
16	3.1537	318.1	2.918	2.236E+07	4.319E+04	1.442E+02	2.489E-03
17	3.1123	318.7	2.918	2.200E+07	4.255E+04	1.421E+02	2.486E-03
18	3.0916	321.5	2.918	2.157E+07	4.201E+04	1.424E+02	2.509E-03
19	3.0909	319.6	2.918	2.175E+07	4.212E+04	1.411E+02	2.487E-03
20	3.0868	319.4	2.918	2.174E+07	4.196E+04	1.400E+02	2.471E-03
21	3.0861	320.8	2.918	2.161E+07	4.203E+04	1.419E 02	2.504E-03
22	3.0764	319.4	2.918	2.167E+07	4.187E+04	1.398E+02	2.475E-03
23	3.0440	319.1	2.918	2.148E+07	4.162E+04	1.388E+02	2.483E-03
24	2.9323	317.5	2.913	2.090E+07	4.031E+04	1.326E+02	2.453E-03
25	2.8131	316.2	2.912	2.018E+07	3.879E+04	1.257E+02	2.421E-03

NSWC TR 79-153

TABLE A-4 SKIN FRICTION DATA LISTING

N	PO*10-5 (N/M2)	TO (DFG.K)	M	RE (1/M)	RETH	TAUW (N/M2)	CF
RUN NO. 822225 K = .1245 CM MDOT = 0.0000 KG/M2S							
26	2.7048	315.8	2.909	1.947E+07	3.767E+04	1.218E+02	2.434E-03
27	2.5731	314.5	2.911	1.862E+07	3.594E+04	1.142E+02	2.403E-03
28	2.4076	312.8	2.909	1.758E+07	3.422E+04	1.075E+02	2.413E-03
29	2.2766	312.1	2.905	1.672E+07	3.266E+04	1.017E+02	2.407E-03
30	2.1491	312.2	2.908	1.574E+07	3.079E+04	9.490E+01	2.385E-03
31	2.0346	312.2	2.907	1.491E+07	2.919E+04	8.910E+01	2.364E-03
32	1.9167	311.7	2.906	1.409E+07	2.782E+04	8.440E+01	2.375E-03
33	1.8154	311.7	2.928	1.319E+07	2.639E+04	7.942E+01	2.403E-03
34	1.6934	312.1	2.903	1.245E+07	2.487E+04	7.462E+01	2.370E-03
35	1.5968	312.6	2.902	1.172E+07	2.358E+04	7.060E+01	2.375E-03
36	1.5024	312.8	2.899	1.103E+07	2.232E+04	6.648E+01	2.373E-03
37	1.4224	313.4	2.902	1.040E+07	2.102E+04	6.188E+01	2.337E-03
38	1.3472	313.6	2.891	9.893E+06	2.004E+04	5.876E+01	2.324E-03
39	1.2604	314.3	2.896	9.201E+06	1.889E+04	5.536E+01	2.349E-03
40	1.1721	314.9	2.886	8.577E+06	1.757E+04	5.095E+01	2.306E-03
41	1.0880	314.7	2.880	7.996E+06	1.646E+04	4.726E+01	2.292E-03
RUN NO. 822229 K = .1245 CM MDOT = 0.0000 KG/M2S							
1	1.9747	317.5	2.919	1.403E+07	2.747E+04	8.467E+01	2.337E-03
2	1.9678	317.5	2.919	1.398E+07	2.729E+04	8.385E+01	2.322E-03
3	1.9622	317.5	2.919	1.394E+07	2.733E+04	8.421E+01	2.339E-03
4	1.9588	317.5	2.919	1.391E+07	2.723E+04	8.373E+01	2.330E-03
5	1.9547	317.7	2.919	1.387E+07	2.720E+04	8.382E+01	2.337E-03
6	1.9450	317.5	2.919	1.382E+07	2.703E+04	8.300E+01	2.325E-03
7	1.8671	315.8	2.914	1.341E+07	2.627E+04	7.975E+01	2.318E-03
8	1.7926	314.7	2.911	1.296E+07	2.529E+04	7.565E+01	2.285E-03
9	1.7299	314.1	2.915	1.251E+07	2.465E+04	7.356E+01	2.310E-03
10	1.6554	313.6	2.910	1.203E+07	2.362E+04	6.956E+01	2.274E-03
11	1.5865	312.8	2.909	1.159E+07	2.278E+04	6.646E+01	2.264E-03
12	1.4803	312.1	2.902	1.089E+07	2.158E+04	6.253E+01	2.270E-03
13	1.3893	312.1	2.909	1.018E+07	2.033E+04	5.840E+01	2.273E-03
14	1.3286	312.8	2.907	9.709E+06	1.938E+04	5.530E+01	2.247E-03
15	1.2755	316.0	2.904	9.197E+06	1.849E+04	5.341E+01	2.254E-03
16	1.2307	319.1	2.906	8.739E+06	1.774E+04	5.183E+01	2.272E-03
17	1.1935	321.9	2.904	8.372E+06	1.711E+04	5.057E+01	2.282E-03
18	1.1631	322.8	2.905	8.122E+06	1.662E+04	4.909E+01	2.274E-03
19	1.1397	323.6	2.907	7.925E+06	1.625E+04	4.795E+01	2.270E-03
20	1.1176	324.5	2.907	7.734E+06	1.596E+04	4.734E+01	2.287E-03
21	1.1004	324.9	2.906	7.607E+06	1.572E+04	4.667E+01	2.287E-03
22	1.0832	325.1	2.906	7.484E+06	1.546E+04	4.577E+01	2.278E-03
23	1.0721	324.9	2.906	7.413E+06	1.532E+04	4.521E+01	2.273E-03
24	1.0549	324.3	2.906	7.310E+06	1.513E+04	4.448E+01	2.275E-03
25	1.0446	323.8	2.907	7.256E+06	1.506E+04	4.419E+01	2.282E-03
26	1.0321	318.5	2.905	7.354E+06	1.513E+04	4.308E+01	2.248E-03
27	1.0315	320.6	2.907	7.268E+06	1.502E+04	4.322E+01	2.262E-03
28	1.0308	321.9	2.907	7.220E+06	1.499E+04	4.356E+01	2.281E-03
29	1.0232	318.1	2.905	7.302E+06	1.507E+04	4.291E+01	2.260E-03
30	.9901	316.8	2.904	7.114E+06	1.464E+04	4.109E+01	2.234E-03
31	.9570	316.4	2.899	6.907E+06	1.425E+04	3.983E+01	2.231E-03
32	.9391	316.4	2.902	6.768E+06	1.399E+04	3.893E+01	2.227E-03
33	.9177	317.0	2.903	6.591E+06	1.371E+04	3.827E+01	2.244E-03
34	.8901	317.0	2.899	6.408E+06	1.333E+04	3.704E+01	2.230E-03
35	.7957	314.9	2.891	5.809E+06	1.210E+04	3.267E+01	2.186E-03
36	.7626	316.2	2.895	5.519E+06	1.163E+04	3.158E+01	2.214E-03
37	.7253	316.2	2.892	5.258E+06	1.107E+04	2.976E+01	2.188E-03
38	.6895	315.8	2.893	5.005E+06	1.062E+04	2.838E+01	2.196E-03
39	.6467	317.0	2.889	4.680E+06	9.979E+03	2.658E+01	2.186E-03
40	.6219	316.8	2.887	4.509E+06	9.660E+03	2.564E+01	2.188E-03

NSWC TR 79-153

TABLE A-4 SKIN FRICTION DATA LISTING

N	PO*10-5 (N/M2)	TO (DEG.K)	M	RE (1/M)	RETH	TAUW (N/M2)	CF
RUN NO.	822229	K =	.1245 CM	MDOT =	0.0000 KG/M2S		
41	.5978	316.6	2.886	4.339E+06	9.308E+03	2.450E+01	2.174E-03
42	.5792	317.3	2.889	4.183E+06	9.037E+03	2.384E+01	2.189E-03
43	.5661	318.1	2.890	4.072E+06	8.831E+03	2.333E+01	2.194E-03
44	.5578	318.5	2.890	4.005E+06	8.715E+03	2.307E+01	2.201E-03
45	.5378	318.3	2.886	3.874E+06	8.451E+03	2.227E+01	2.195E-03
46	.5281	317.0	2.894	3.811E+06	8.327E+03	2.171E+01	2.195E-03
47	.5281	316.8	2.894	3.815E+06	8.313E+03	2.159E+01	2.183E-03
48	.5261	317.0	2.894	3.797E+06	8.317E+03	2.173E+01	2.205E-03
49	.5254	317.2	2.894	3.788E 06	8.276E+03	2.156E+01	2.192E-03
50	.5247	318.3	2.887	3.777E+06	8.234E+03	2.154E+01	2.179E-03
51	.5226	317.9	2.893	3.757E+06	8.228E+03	2.154E+01	2.198E-03
52	.5164	320.4	2.894	3.668E+06	8.080E+03	2.142E+01	2.214E-03
53	.5157	319.4	2.893	3.682E+06	8.096E+03	2.134E+01	2.207E-03
54	.4902	317.0	2.885	3.555E+06	7.772E+03	1.999E+01	2.160E-03
55	.4723	316.4	2.880	3.443E+06	7.525E+03	1.916E+01	2.141E-03
56	.4557	316.0	2.880	3.329E+06	7.321E+03	1.860E+01	2.154E-03
57	.4371	315.5	2.872	3.214E+06	7.033E+03	1.758E+01	2.109E-03
58	.4178	315.3	2.870	3.078E+06	6.775E+03	1.688E+01	2.115E-03
59	.4006	314.9	2.871	2.955E+06	6.547E+03	1.625E+01	2.125E-03
60	.3847	314.5	2.866	2.851E+06	6.298E+03	1.543E+01	2.092E-03
61	.3620	313.0	2.858	2.713E+06	6.004E+03	1.448E+01	2.073E-03
62	.3427	311.9	2.856	2.584E+06	5.755E+03	1.375E+01	2.078E-03
63	.3234	311.1	2.856	2.448E+06	5.467E+03	1.288E+01	2.061E-03
64	.2992	310.5	2.846	2.283E+06	5.103E+03	1.181E+01	2.026E-03
65	.2772	310.0	2.843	2.124E+06	4.755E+03	1.079E+01	1.995E-03
66	.2517	309.2	2.830	1.948E+06	4.383E+03	9.775E+00	1.968E-03

NSWC TR 79-153

TABLE A-4 SKIN FRICTION DATA LISTING

N	PO*10-5 (N/M2)	TO (DEG.K)	M	RE (1/M)	RETH	TAUW (N/M2)	CF
RUN NO.	822222	K =	.1245 CM	MDOT =	.0146 KG/M2S		
1	.7046	314.7	2.913	5.088E+06	1.146E+04	2.325E+01	1.790E-03
2	.6977	315.1	2.913	5.030E+06	1.136E+04	2.303E+01	1.790E-03
3	.6922	314.1	2.908	5.025E+06	1.134E+04	2.284E+01	1.783E-03
4	.6784	320.0	2.911	4.786E+06	1.093E+04	2.250E+01	1.795E-03
5	.6764	315.5	2.916	4.860E+06	1.106E+04	2.223E+01	1.786E-03
6	.6722	313.9	2.908	4.884E+06	1.107E+04	2.199E+01	1.767E-03
7	.6647	319.1	2.908	4.714E+06	1.077E+04	2.187E+01	1.778E-03
8	.6412	317.7	2.905	4.584E+06	1.051E+04	2.092E+01	1.758E-03
9	.6212	313.2	2.904	4.539E+06	1.042E+04	2.004E+01	1.737E-03
10	.6198	317.0	2.902	4.454E+06	1.024E+04	1.999E+01	1.733E-03
11	.6088	313.4	2.902	4.449E+06	1.025E+04	1.963E+01	1.734E-03
12	.5902	315.8	2.901	4.265E+06	9.895E+03	1.888E+01	1.718E-03
13	.5605	315.6	2.915	4.026E+06	9.452E+03	1.749E+01	1.695E-03
14	.5550	313.4	2.897	4.068E+06	9.485E+03	1.736E+01	1.674E-03
15	.5543	315.1	2.899	4.024E+06	9.424E+03	1.741E+01	1.685E-03
16	.5385	315.6	2.914	3.869E+06	9.159E+03	1.668E+01	1.682E-03
17	.5330	313.6	2.895	3.906E+06	9.192E+03	1.660E+01	1.665E-03
18	.5240	314.1	2.893	3.834E+06	9.057E+03	1.631E+01	1.660E-03
19	.5109	315.5	2.912	3.678E+06	8.783E+03	1.558E+01	1.653E-03
20	.4868	313.2	2.888	3.586E+06	8.555E+03	1.476E+01	1.611E-03
21	.4806	315.3	2.911	3.465E+06	8.361E+03	1.435E+01	1.617E-03
22	.4785	313.0	2.890	3.527E+06	8.432E+03	1.436E+01	1.596E-03
23	.4626	313.6	2.891	3.399E+06	8.200E+03	1.380E+01	1.588E-03
24	.4454	315.1	2.910	3.215E+06	7.865E+03	1.292E+01	1.569E-03
25	.4378	312.4	2.881	3.249E+06	7.878E+03	1.278E+01	1.543E-03
26	.4240	315.1	2.913	3.057E+06	7.546E+03	1.198E+01	1.533E-03
27	.4220	313.6	2.879	3.119E+06	7.629E+03	1.222E+01	1.528E-03
28	.4082	311.7	2.876	3.049E+06	7.489E+03	1.169E+01	1.507E-03
29	.4006	314.9	2.908	2.898E+06	7.230E+03	1.112E+01	1.499E-03
30	.3833	313.4	2.872	2.846E+06	7.087E+03	1.074E+01	1.470E-03
31	.3771	314.9	2.913	2.721E+06	6.892E+03	1.020E+01	1.467E-03
32	.3544	314.9	2.912	2.558E+06	6.588E+03	9.442E+00	1.444E-03
33	.3482	312.1	2.866	2.610E+06	6.614E+03	9.381E+00	1.406E-03
34	.3323	315.3	2.913	2.393E+06	6.250E+03	8.529E+00	1.393E-03
35	.3130	315.8	2.915	2.246E+06	5.974E+03	7.881E+00	1.368E-03
36	.2930	316.2	2.922	2.091E+06	5.673E+03	7.105E+00	1.325E-03
37	.2744	316.4	2.926	1.952E+06	5.410E+03	6.468E+00	1.292E-03
38	.2551	316.4	2.952	1.790E+06	5.134E+03	5.784E+00	1.270E-03
39	.2068	316.0	2.968	1.442E+06	4.497E+03	4.360E+00	1.197E-03
40	.1855	315.5	2.970	1.295E+06	4.218E+03	3.748E+00	1.149E-03
41	.1669	314.7	2.973	1.168E+06	3.965E+03	3.154E+00	1.077E-03
42	.1455	313.9	2.940	1.039E+06	3.691E+03	2.646E+00	1.009E-03
RUN NO.	822226	K =	.1245 CM	MDOT =	.0146 KG/M2S		
1	3.6328	320.8	2.920	2.541E 07	4.898E+04	1.595E+02	2.395E-03
2	3.6011	320.6	2.920	2.521E+07	4.867E+04	1.582E+02	2.397E-03
3	3.5860	320.6	2.920	2.511E+07	4.848E+04	1.575E+02	2.395E-03
4	3.5680	320.9	2.920	2.493E+07	4.812E+04	1.563E+02	2.389E-03
5	3.5529	320.9	2.920	2.483E+07	4.802E+04	1.561E+02	2.396E-03
6	3.5356	321.1	2.919	2.469E+07	4.790E+04	1.560E+02	2.406E-03
7	3.4922	320.6	2.918	2.447E+07	4.725E+04	1.527E+02	2.381E-03
8	3.4012	319.4	2.917	2.398E+07	4.616E+04	1.472E+02	2.355E-03
9	1.7161	316.8	2.900	1.236E+07	2.536E+04	7.038E+01	2.201E-03
10	1.6099	317.7	2.894	1.158E+07	2.400E+04	6.626E+01	2.197E-03
11	1.5217	318.5	2.892	1.092E+07	2.256E+04	6.103E+01	2.138E-03
12	1.4231	319.1	2.893	1.018E+07	2.144E+04	5.796E+01	2.173E-03
13	1.2928	319.4	2.894	9.224E+06	1.949E+04	5.092E+01	2.103E-03
14	1.1335	317.5	2.889	8.181E+06	1.752E+04	4.387E+01	2.058E-03

NSWC TR 79-153

TABLE A-4 SKIN FRICTION DATA LISTING

N	PO*10-5 (N/M2)	TO (DEG.K)	M	RE (1/M)	RETH	TAUW (N/M2)	CF
RUN NO. 822210 K = .1245 CM MDOT = .0146 KG/M2S							
1	2.0657	317.0	2.919	1.471E+07	2.949E+04	8.407E+01	2.219E-03
2	2.0567	316.8	2.919	1.466E+07	2.944E+04	8.390E+01	2.224E-03
3	2.0415	316.4	2.919	1.458E+07	2.919E+04	8.266E+01	2.207E-03
4	2.0188	316.4	2.919	1.442E+07	2.896E+04	8.196E+01	2.212E-03
5	1.9698	315.5	2.916	1.415E+07	2.844E+04	7.975E+01	2.202E-03
6	1.8471	311.9	2.907	1.356E+07	2.722E+04	7.405E+01	2.164E-03
7	1.2604	310.0	2.901	9.369E+06	1.961E+04	4.835E+01	2.060E-03
8	1.1997	311.3	2.903	8.852E+06	1.865E+04	4.553E+01	2.041E-03
9	1.1466	315.1	2.905	8.302E+06	1.769E+04	4.344E+01	2.041E-03
10	1.1245	317.3	2.906	8.050E+06	1.722E+04	4.242E+01	2.034E-03
11	1.1025	318.7	2.905	7.849E+06	1.688E+04	4.172E+01	2.038E-03
12	1.0818	318.9	2.906	7.690E+06	1.660E+04	4.085E+01	2.036E-03
13	1.0756	319.8	2.908	7.605E+06	1.647E+04	4.065E+01	2.041E-03
14	1.0742	319.2	2.907	7.618E+06	1.654E+04	4.089E+01	2.055E-03
15	1.0570	319.1	2.905	7.510E+06	1.628E+04	3.990E+01	2.037E-03
16	1.0377	319.2	2.906	7.363E+06	1.598E+04	3.886E+01	2.019E-03
17	1.0377	319.2	2.907	7.361E+06	1.602E+04	3.912E+01	2.034E-03
18	1.0349	319.4	2.906	7.335E+06	1.595E+04	3.890E+01	2.028E-03
19	1.0294	319.6	2.906	7.292E+06	1.591E+04	3.888E+01	2.037E-03
20	.5764	316.2	2.893	4.176E+06	9.790E+03	1.888E+01	1.748E-03
21	.5661	319.4	2.905	4.016E+06	9.525E+03	1.849E+01	1.760E-03
22	.5530	315.5	2.868	4.073E+06	9.472E+03	1.774E+01	1.677E-03
23	.5405	318.5	2.898	3.865E+06	9.206E+03	1.743E+01	1.727E-03
24	.5337	317.2	2.889	3.858E+06	9.139E+03	1.701E+01	1.695E-03
25	.5323	317.0	2.886	3.858E+06	9.113E+03	1.687E+01	1.681E-03
26	.5226	316.2	2.886	3.802E+06	9.043E+03	1.670E+01	1.694E-03
27	.5199	317.5	2.896	3.737E+06	8.926E+03	1.643E+01	1.691E-03
28	.5047	315.6	2.896	3.662E+06	8.794E+03	1.590E+01	1.684E-03
29	.5047	315.6	2.887	3.679E+06	8.798E+03	1.590E+01	1.672E-03
30	.4971	315.6	2.887	3.623E+06	8.701E+03	1.565E+01	1.672E-03
31	.4619	313.6	2.869	3.433E+06	8.272E+03	1.420E+01	1.607E-03
RUN NO. 822223 K = .1245 CM MDOT = .0488 KG/M2S							
1	.9087	315.6	2.910	6.542E+06	1.649E+04	2.348E+01	1.398E-03
2	.8784	318.7	2.915	6.218E+06	1.604E+04	2.302E+01	1.424E-03
3	.8570	315.5	2.906	6.188E+06	1.591E+04	2.194E+01	1.381E-03
4	.8322	315.3	2.907	6.012E+06	1.561E+04	2.105E+01	1.365E-03
5	.8108	318.9	2.913	5.743E+06	1.515E+04	2.030E+01	1.358E-03
6	.8005	315.3	2.905	5.788E+06	1.523E+04	2.000E+01	1.347E-03
7	.7757	315.1	2.902	5.623E+06	1.489E+04	1.893E+01	1.312E-03
8	.7591	318.7	2.915	5.375E+06	1.446E+04	1.814E+01	1.298E-03
9	.7495	314.9	2.900	5.445E+06	1.457E+04	1.800E+01	1.288E-03
10	.7233	314.9	2.901	5.251E+06	1.422E+04	1.699E+01	1.261E-03
11	.6964	314.9	2.897	5.066E+06	1.384E+04	1.582E+01	1.216E-03
12	.6860	318.1	2.914	4.872E+06	1.353E+04	1.528E+01	1.209E-03
13	.6612	314.9	2.895	4.816E+06	1.338E+04	1.440E+01	1.164E-03
14	.6426	317.7	2.911	4.580E+06	1.299E+04	1.373E+01	1.156E-03
15	.6336	314.7	2.891	4.629E+06	1.301E+04	1.343E+01	1.129E-03
16	.5764	314.7	2.889	4.216E+06	1.227E+04	1.143E+01	1.054E-03
17	.5592	316.8	2.907	4.011E+06	1.191E+04	1.049E+01	1.012E-03
18	.5454	314.5	2.886	3.998E+06	1.184E+04	1.014E+01	9.864E-04
19	.5337	316.8	2.908	3.827E+06	1.157E+04	9.542E+00	9.656E-04
20	.4592	316.6	2.914	3.286E+06	1.063E+04	7.036E+00	8.314E-04
21	.4095	316.4	2.906	2.944E+06	9.966E+03	5.299E+00	6.979E-04
22	.3613	316.2	2.911	2.594E+06	9.385E+03	3.964E+00	5.938E-04

NSWC TR 79-153

TABLE A-4 SKIN FRICTION DATA LISTING

N	PC*10-5 (N/M2)	T0 (DFG.K)	M	RE (1/M)	RETH	TAUW (N/M2)	CF
RUN NO.	822227	K =	.1245 CM	MDOT =	.0488 KG/M2S		
1	4.1582	330.4	2.922	2.781E+07	5.543E+04	1.756E+02	2.308E-03
2	4.1417	328.9	2.922	2.789E+07	5.552E+04	1.745E+02	2.301E-03
3	4.1417	327.9	2.922	2.800E+07	5.562E+04	1.739E+02	2.294E-03
4	4.1382	328.3	2.922	2.793E+07	5.546E+04	1.735E+02	2.291E-03
5	4.1189	318.1	2.921	2.914E+07	5.796E+04	1.751E+02	2.321E-03
6	4.0024	313.8	2.917	2.897E+07	5.730E+04	1.682E+02	2.287E-03
7	3.5667	310.9	2.914	2.621E+07	5.228E+04	1.468E+02	2.233E-03
8	3.3315	312.8	2.914	2.426E+07	4.916E+04	1.373E+02	2.237E-03
9	3.1819	324.7	2.918	2.188E+07	4.497E+04	1.299E+02	2.223E-03
10	3.1806	313.6	2.918	2.303E+07	4.712E+04	1.304E+02	2.233E-03
11	3.1530	323.8	2.918	2.178E+07	4.476E+04	1.283E+02	2.216E-03
12	3.1116	323.2	2.918	2.154E+07	4.439E+04	1.266E+02	2.216E-03
13	3.0902	323.0	2.918	2.141E+07	4.407E+04	1.251E+02	2.204E-03
14	3.0440	323.0	2.918	2.109E+07	4.341E+04	1.223E+02	2.189E-03
15	2.9689	311.3	2.909	2.184E+07	4.463E+04	1.194E+02	2.174E-03
16	2.9592	322.3	2.917	2.059E+07	4.251E+04	1.185E+02	2.179E-03
17	2.7896	319.4	2.911	1.973E+07	4.078E+04	1.101E+02	2.137E-03
18	2.7827	309.4	2.906	2.069E+07	4.279E+04	1.120E+02	2.171E-03
19	2.6179	319.1	2.911	1.854E+07	3.860E+04	1.016E+02	2.102E-03
20	2.5662	309.4	2.909	1.904E+07	3.982E+04	1.012E+02	2.133E-03
21	2.4718	320.8	2.911	1.737E+07	3.680E+04	9.658E+01	2.115E-03
22	2.3897	309.4	2.909	1.774E+07	3.722E+04	9.154E+01	2.070E-03
23	2.3187	322.1	2.912	1.619E+07	3.463E+04	8.914E+01	2.083E-03
24	2.2346	323.2	2.907	1.556E+07	3.347E+04	8.554E+01	2.066E-03
25	2.1643	323.6	2.906	1.505E+07	3.252E+04	8.218E+01	2.048E-03
26	2.1401	309.0	2.910	1.591E+07	3.437E+04	8.233E+01	2.081E-03
27	2.0677	316.0	2.914	1.483E+07	3.217E+04	7.725E+01	2.028E-03
28	2.0402	320.8	2.902	1.441E+07	3.135E+04	7.681E+01	2.023E-03
29	1.9085	318.1	2.903	1.364E+07	2.988E+04	7.019E+01	1.978E-03
30	1.8209	310.7	2.901	1.349E+07	2.989E+04	6.784E+01	2.000E-03
31	1.7892	308.6	2.903	1.337E+07	2.970E+04	6.625E+01	1.993E-03
32	1.7602	314.9	2.910	1.272E+07	2.881E+04	6.625E+01	2.037E-03
33	1.7451	316.8	2.894	1.260E+07	2.772E+04	6.170E+01	1.888E-03
34	1.6423	312.1	2.902	1.208E+07	2.721E+04	5.891E+01	1.927E-03
35	1.6120	316.4	2.895	1.166E+07	2.597E+04	5.536E+01	1.836E-03
36	1.5189	313.2	2.902	1.111E+07	2.542E+04	5.325E+01	1.884E-03
37	1.4872	315.8	2.889	1.082E+07	2.442E+04	5.004E+01	1.789E-03
38	1.4052	315.5	2.898	1.019E+07	2.380E+04	4.889E+01	1.863E-03
39	1.3555	313.9	2.883	9.982E+06	2.283E+04	4.414E+01	1.722E-03
40	1.3238	315.5	2.888	9.651E+06	2.257E+04	4.442E+01	1.783E-03
41	1.2369	315.8	2.895	8.970E+06	2.141E+04	4.078E+01	1.762E-03
42	1.2314	312.6	2.877	9.154E+06	2.133E+04	3.896E+01	1.665E-03
43	1.1376	315.6	2.889	8.284E+06	2.014E+04	3.665E+01	1.713E-03
44	1.1349	312.6	2.878	8.429E+06	1.998E+04	3.454E+01	1.604E-03

NSWC TR 79-153

TABLE A-4 SKIN FRICTION DATA LISTING

N	PO*10-5 (N/M2)	TO (DFG.K)	M	RE (1/M)	RETH	TAUW (N/M2)	CF
RUN NO.	822211	K =	.1245 CM	MDOT =	.0488 KG/M2S		
1	2.0677	316.2	2.914	1.482E+07	3.207E+04	7.682E+01	2.017E-03
2	2.0670	316.2	2.914	1.481E+07	3.203E+04	7.660E+01	2.011E-03
3	2.0629	316.0	2.914	1.480E+07	3.201E+04	7.650E+01	2.013E-03
4	2.0209	314.9	2.913	1.458E+07	3.163E+04	7.470E+01	2.006E-03
5	1.9740	314.5	2.909	1.430E+07	3.110E+04	7.273E+01	1.991E-03
6	1.9333	314.5	2.912	1.398E+07	3.060E+04	7.106E+01	1.992E-03
7	1.8954	314.9	2.908	1.371E+07	3.007E+04	6.943E+01	1.979E-03
8	1.8719	315.3	2.910	1.350E+07	2.964E+04	6.790E+01	1.963E-03
9	1.8478	316.2	2.910	1.327E+07	2.932E+04	6.741E+01	1.974E-03
10	1.8188	316.0	2.909	1.308E+07	2.896E+04	6.612E+01	1.965E-03
11	1.7733	315.3	2.908	1.280E 07	2.847E+04	6.413E+01	1.954E-03
12	1.7375	314.9	2.907	1.258E+07	2.794E+04	6.194E+01	1.924E-03
13	1.6961	314.7	2.907	1.228E+07	2.737E+04	5.978E+01	1.903E-03
14	1.6603	314.5	2.909	1.203E+07	2.700E+04	5.864E+01	1.909E-03
15	1.6037	314.9	2.908	1.160E+07	2.625E+04	5.635E+01	1.899E-03
16	1.5389	314.7	2.907	1.115E+07	2.538E+04	5.327E+01	1.867E-03
17	1.4851	314.5	2.903	1.079E+07	2.466E+04	5.074E+01	1.837E-03
18	1.4451	314.9	2.905	1.047E+07	2.408E+04	4.887E+01	1.821E-03
19	1.4100	314.7	2.902	1.024E+07	2.363E+04	4.729E+01	1.803E-03
20	1.3645	313.9	2.901	9.953E+06	2.306E+04	4.513E+01	1.776E-03
21	1.3210	313.9	2.904	9.621E+06	2.252E+04	4.342E+01	1.769E-03
22	1.2873	315.6	2.903	9.302E+06	2.198E+04	4.226E+01	1.766E-03
23	1.2493	315.5	2.901	9.047E+06	2.146E+04	4.044E+01	1.738E-03
24	1.1880	324.9	2.906	8.211E+06	2.006E+04	3.864E+01	1.754E-03
25	1.1818	315.8	2.897	8.560E+06	2.055E+04	3.759E+01	1.703E-03
26	1.1480	318.1	2.902	8.206E+06	1.997E+04	3.638E+01	1.703E-03
27	1.1225	318.9	2.899	8.007E+06	1.944E+04	3.448E+01	1.647E-03
28	1.0342	318.3	2.900	7.393E+06	1.839E+04	3.118E+01	1.618E-03
29	1.0321	318.3	2.900	7.381E+06	1.835E+04	3.098E+01	1.610E-03
30	1.0315	318.3	2.900	7.374E+06	1.834E+04	3.098E+01	1.612E-03
31	1.0273	318.3	2.899	7.350E+06	1.837E+04	3.127E+01	1.632E-03
32	1.0259	318.5	2.900	7.327E+06	1.827E+04	3.084E+01	1.613E-03
33	1.0156	318.9	2.900	7.241E+06	1.814E+04	3.055E+01	1.614E-03
34	1.0025	317.5	2.895	7.212E+06	1.799E+04	2.965E+01	1.580E-03
35	1.0011	319.1	2.901	7.130E+06	1.791E+04	2.982E+01	1.599E-03
36	.9991	314.5	2.893	7.298E+06	1.814E+04	2.943E+01	1.571E-03
37	.9749	316.8	2.893	7.046E+06	1.764E+04	2.829E+01	1.548E-03
38	.9680	318.9	2.901	6.899E+06	1.749E+04	2.841E+01	1.576E-03
39	.9446	316.2	2.894	6.841E+06	1.736E+04	2.753E+01	1.556E-03
40	.9315	316.2	2.891	6.757E+06	1.717E+04	2.685E+01	1.535E-03
41	.9308	319.6	2.902	6.607E+06	1.697E+04	2.697E+01	1.557E-03
42	.9205	316.2	2.895	6.664E+06	1.698E+04	2.617E+01	1.519E-03
43	.9046	316.8	2.893	6.537E+06	1.675E+04	2.559E+01	1.509E-03
44	.8901	319.8	2.900	6.318E+06	1.642E+04	2.525E+01	1.522E-03
45	.8736	316.8	2.891	6.319E+06	1.629E+04	2.406E+01	1.467E-03
46	.8398	316.2	2.891	6.092E+06	1.586E+04	2.260E+01	1.433E-03
47	.8184	318.7	2.899	5.844E+06	1.556E+04	2.243E+01	1.469E-03
48	.8081	316.0	2.889	5.872E+06	1.549E+04	2.155E+01	1.418E-03
49	.7812	313.8	2.895	5.721E+06	1.525E+04	2.041E+01	1.396E-03
50	.7791	316.4	2.887	5.657E+06	1.500E+04	1.990E+01	1.357E-03
51	.7398	316.0	2.885	5.389E+06	1.453E+04	1.854E+01	1.328E-03
52	.7102	315.8	2.884	5.180E+06	1.415E+04	1.745E+01	1.301E-03
53	.6902	315.8	2.885	5.032E+06	1.385E+04	1.645E+01	1.263E-03
54	.6709	316.4	2.885	4.876E+06	1.363E+04	1.609E+01	1.271E-03
55	.6571	317.0	2.886	4.763E+06	1.339E+04	1.538E+01	1.241E-03

NSWC TR 79-153

TABLE A-4 SKIN FRICTION DATA LISTING

N	PO*10-5 (N/M2)	TO (DEG.K)	M	RE (1/M)	RETH	TAUW (N/M2)	CF
RUN NO.	822211	K =	.1245 CM	MDOT =	.0488 KG/M2S		
56	.6419	317.2	2.883	4.655E+06	1.314E+04	1.458E+01	1.202E-03
57	.6267	317.2	2.883	4.545E+06	1.294E+04	1.397E+01	1.180E-03
58	.6067	317.0	2.880	4.411E+06	1.267E+04	1.319E+01	1.148E-03
59	.5881	317.3	2.882	4.263E+06	1.244E+04	1.266E+01	1.138E-03
60	.5778	317.5	2.880	4.190E+06	1.227E+04	1.217E+01	1.112E-03
61	.5674	317.7	2.880	4.111E+06	1.211E+04	1.169E+01	1.087E-03
62	.5564	317.7	2.879	4.032E+06	1.197E+04	1.132E+01	1.073E-03
63	.5474	317.9	2.880	3.963E+06	1.185E+04	1.098E+01	1.059E-03
64	.5405	318.1	2.880	3.909E+06	1.173E+04	1.064E+01	1.039E-03
65	.5357	318.3	2.881	3.868E+06	1.168E+04	1.059E+01	1.045E-03
66	.5309	318.5	2.880	3.832E+06	1.161E+04	1.042E+01	1.036E-03
67	.5268	318.7	2.882	3.796E+06	1.154E+04	1.020E+01	1.024E-03
68	.5247	318.9	2.882	3.777E+06	1.152E+04	1.023E+01	1.031E-03
69	.5240	319.2	2.881	3.768E+06	1.147E+04	1.006E+01	1.014E-03
70	.5233	319.2	2.861	3.802E+06	1.146E+04	1.011E+01	1.004E-03
71	.5226	319.1	2.880	3.762E+06	1.147E+04	1.008E+01	1.019E-03
72	.5199	319.2	2.881	3.739E+06	1.143E+04	1.001E+01	1.017E-03
73	.5178	319.4	2.881	3.720E+06	1.139E+04	9.889E+00	1.009E-03
74	.5150	319.6	2.881	3.697E+06	1.135E+04	9.816E+00	1.006E-03
75	.5150	319.8	2.882	3.691E+06	1.135E+04	9.840E+00	1.010E-03
76	.5143	317.9	2.877	3.730E+06	1.140E+04	9.767E+00	9.995E-04
77	.5130	320.0	2.881	3.675E+06	1.133E+04	9.864E+00	1.016E-03
78	.4861	316.4	2.872	3.559E+06	1.108E+04	8.698E+00	9.382E-04
79	.4406	315.3	2.864	3.256E+06	1.052E+04	7.167E+00	8.474E-04
80	.4275	314.9	2.865	3.164E+06	1.033E+04	6.559E+00	7.997E-04
81	.4158	314.9	2.861	3.083E+06	1.020E+04	6.341E+00	7.927E-04
82	.4061	314.7	2.860	3.015E+06	1.007E+04	5.952E+00	7.611E-04
83	.3971	314.7	2.860	2.949E+06	9.931E+03	5.539E+00	7.241E-04
84	.3882	314.7	2.859	2.884E+06	9.812E+03	5.247E+00	7.014E-04
85	.3778	314.5	2.856	2.814E+06	9.693E+03	5.004E+00	6.853E-04
86	.3682	314.3	2.858	2.742E+06	9.573E+03	4.688E+00	6.599E-04
87	.3599	314.3	2.852	2.688E+06	9.503E+03	4.688E+00	6.722E-04
88	.3489	314.1	2.848	2.615E+06	9.335E+03	4.202E+00	6.191E-04
89	.3385	313.8	2.845	2.545E+06	9.200E+03	3.837E+00	5.815E-04
90	.3261	313.0	2.840	2.467E+06	9.069E+03	3.546E+00	5.554E-04
91	.3130	312.1	2.841	2.378E+06	8.939E+03	3.230E+00	5.274E-04
92	.2999	311.1	2.836	2.295E+06	8.800E+03	2.914E+00	4.945E-04
93	.2882	310.3	2.833	2.216E+06	8.681E+03	2.671E+00	4.709E-04
94	.2744	309.6	2.826	2.125E+06	8.529E+03	2.379E+00	4.380E-04
95	.2627	308.8	2.815	2.054E+06	8.396E+03	2.136E+00	4.070E-04

NSWC TR 79-153

TABLE A-4 SKIN FRICTION DATA LISTING

N	PO#10-5 (N/M2)	TO (DFG.K)	M	RE (1/M)	RETH	TAUW (N/M2)	CF
RUN NO. 822224 K = .1245 CM MDOT = .1465 KG/M2S							
1	1.3934	317.2	2.916	9.930E+06	2.974E+04	2.281E+01	8.903E-04
2	1.3645	315.5	2.908	9.844E+06	2.950E+04	2.152E+01	8.518E-04
3	1.3321	318.7	2.914	9.435E+06	2.880E+04	2.028E+01	8.265E-04
4	1.2673	317.2	2.904	9.088E+06	2.818E+04	1.815E+01	7.710E-04
5	1.2473	319.6	2.913	8.802E+06	2.772E+04	1.728E+01	7.512E-04
6	1.2107	317.7	2.901	8.673E+06	2.745E+04	1.617E+01	7.175E-04
7	1.1604	319.2	2.904	8.240E+06	2.674E+04	1.446E+01	6.713E-04
8	1.1535	317.7	2.897	8.281E+06	2.678E+04	1.428E+01	6.628E-04
9	1.1094	317.5	2.894	7.986E+06	2.624E+04	1.258E+01	6.053E-04
10	1.0777	317.5	2.893	7.761E+06	2.591E+04	1.178E+01	5.830E-04
11	1.0535	316.4	2.899	7.603E+06	2.574E+04	1.091E+01	5.554E-04
12	1.0466	313.6	2.896	7.665E+06	2.588E+04	1.056E+01	5.399E-04
13	1.0411	317.0	2.896	7.504E+06	2.550E+04	1.026E+01	5.273E-04
14	1.0411	316.8	2.897	7.509E+06	2.555E+04	1.048E+01	5.388E-04
15	1.0411	315.8	2.896	7.544E+06	2.560E+04	1.032E+01	5.303E-04
16	1.0404	317.0	2.896	7.500E+06	2.553E+04	1.048E+01	5.386E-04
17	1.0404	317.0	2.896	7.500E+06	2.557E+04	1.070E+01	5.503E-04
18	1.0356	317.7	2.890	7.463E+06	2.538E+04	1.033E+01	5.309E-04
19	1.0128	318.7	2.892	7.257E+06	2.508E+04	9.787E+00	5.153E-04
20	.9922	317.5	2.890	7.155E+06	2.493E+04	9.120E+00	4.899E-04
21	.9660	317.9	2.886	6.970E+06	2.463E+04	8.550E+00	4.694E-04
22	.9211	317.7	2.886	6.650E+06	2.411E+04	7.038E+00	4.054E-04
23	.8756	317.5	2.881	6.346E+06	2.361E+04	5.827E+00	3.515E-04
24	.8412	318.1	2.881	6.080E+06	2.325E+04	5.201E+00	3.266E-04
25	.8267	317.2	2.880	6.006E+06	2.317E+04	4.904E+00	3.130E-04
26	.8212	318.5	2.882	5.923E+06	2.303E+04	4.826E+00	3.107E-04
27	.7715	315.8	2.876	5.652E+06	2.271E+04	3.778E+00	2.576E-04
28	.7239	313.9	2.865	5.381E+06	2.234E+04	2.903E+00	2.091E-04
29	.7177	312.6	2.869	5.358E+06	2.240E+04	2.851E+00	2.077E-04
30	.6902	312.2	2.867	5.166E+06	2.218E+04	2.507E+00	1.897E-04
31	.6433	310.7	2.864	4.857E+06	2.186E+04	1.974E+00	1.599E-04
32	.6040	308.6	2.852	4.635E+06	2.163E+04	1.670E+00	1.426E-04
33	.5971	310.1	2.851	4.551E+06	2.147E+04	1.695E+00	1.464E-04
34	.5654	319.4	2.871	4.084E+06	2.066E+04	1.510E+00	1.399E-04
35	.5557	311.7	2.851	4.205E+06	2.102E+04	1.451E+00	1.346E-04
36	.5426	309.8	2.845	4.158E+06	2.101E+04	1.358E+00	1.284E-04
RUN NO. 822228 K = .1245 CM MDOT = .1465 KG/M2S							
1	4.1506	322.5	2.918	2.803E+07	6.240E+04	1.445E+02	1.896E-03
2	4.1486	328.3	2.918	2.806E+07	6.116E+04	1.452E+02	1.907E-03
3	4.1486	324.0	2.918	2.862E+07	6.220E+04	1.454E+02	1.909E-03
4	4.1465	329.8	2.918	2.785E+07	6.068E+04	1.444E+02	1.897E-03
5	4.1382	327.2	2.918	2.814E+07	6.124E+04	1.444E+02	1.900E-03
6	4.1300	324.9	2.918	2.837E+07	6.168E+04	1.441E+02	1.900E-03
7	4.1231	325.7	2.918	2.822E+07	6.141E+04	1.437E+02	1.898E-03
8	4.1120	317.9	2.919	2.916E+07	6.321E+04	1.437E+02	1.905E-03
9	4.0900	315.1	2.918	2.941E+07	6.357E+04	1.423E+02	1.895E-03
10	4.0596	314.1	2.919	2.930E+07	6.340E+04	1.407E+02	1.884E-03
11	3.7080	313.6	2.915	2.690E+07	5.914E+04	1.243E+02	1.820E-03
12	3.5522	314.3	2.911	2.573E+07	5.690E+04	1.164E+02	1.774E-03
13	3.3605	312.8	2.908	2.455E+07	5.470E+04	1.064E+02	1.718E-03
14	3.0909	309.6	2.907	2.294E+07	5.200E+04	9.479E+01	1.656E-03
15	2.8634	308.4	2.903	2.142E+07	4.971E+04	8.682E+01	1.630E-03
16	2.5062	308.2	2.897	1.883E+07	4.493E+04	6.975E+01	1.489E-03
17	2.3601	310.0	2.898	1.757E+07	4.286E+04	6.379E+01	1.448E-03
18	2.1629	317.0	2.899	1.556E+07	3.944E+04	5.600E+01	1.389E-03
19	2.0664	317.0	2.906	1.482E+07	3.841E+04	5.269E+01	1.375E-03
20	2.0643	316.8	2.906	1.482E+07	3.840E+04	5.254E+01	1.372E-03
21	2.0588	316.6	2.906	1.479E+07	3.831E+04	5.201E+01	1.362E-03
22	2.0477	316.2	2.905	1.474E+07	3.818E+04	5.129E+01	1.350E-03

NSWC TR 79-153

TABLE A-4 SKIN FRICTION DATA LISTING

N	P0*10-5 (N/M2)	TO (DEG.K)	M	RE (1/M)	RETH	TAUW (N/M2)	CF
RUN NO.	822212	K =	.1245 CM	MDOT =	.1465 KG/M2S		
1	2.0698	316.6	2.908	1.486E+07	3.838E+04	5.203E+01	1.357E-03
2	2.0684	316.6	2.907	1.485E+07	3.831E+04	5.172E+01	1.350E-03
3	2.0636	316.6	2.907	1.481E+07	3.822E+04	5.133E+01	1.343E-03
4	2.0574	316.6	2.907	1.477E+07	3.818E+04	5.125E+01	1.345E-03
5	2.0450	316.6	2.907	1.468E+07	3.804E+04	5.084E+01	1.342E-03
6	2.0374	317.0	2.908	1.460E+07	3.789E+04	5.045E+01	1.337E-03
7	2.0367	316.2	2.907	1.465E+07	3.795E+04	5.023E+01	1.330E-03
8	2.0298	317.3	2.907	1.452E+07	3.772E+04	5.001E+01	1.330E-03
9	2.0146	317.7	2.908	1.438E+07	3.745E+04	4.918E+01	1.318E-03
10	2.0064	315.8	2.905	1.447E+07	3.761E+04	4.889E+01	1.313E-03
11	1.9981	318.3	2.908	1.422E+07	3.724E+04	4.886E+01	1.321E-03
12	1.9802	315.6	2.904	1.430E+07	3.732E+04	4.789E+01	1.302E-03
13	1.9602	315.8	2.907	1.413E+07	3.714E+04	4.752E+01	1.308E-03
14	1.9360	316.0	2.905	1.395E+07	3.671E+04	4.591E+01	1.278E-03
15	1.9147	316.2	2.905	1.379E+07	3.647E+04	4.532E+01	1.275E-03
16	1.8933	316.4	2.903	1.363E+07	3.614E+04	4.423E+01	1.257E-03
17	1.8699	316.2	2.904	1.347E+07	3.596E+04	4.374E+01	1.259E-03
18	1.8540	316.2	2.904	1.335E+07	3.574E+04	4.291E+01	1.246E-03
19	1.8312	315.8	2.904	1.322E+07	3.548E+04	4.184E+01	1.230E-03
20	1.7857	314.5	2.902	1.298E+07	3.505E+04	3.981E+01	1.198E-03
21	1.7582	313.9	2.903	1.281E+07	3.481E+04	3.881E+01	1.187E-03
22	1.7327	313.4	2.903	1.266E+07	3.453E+04	3.759E+01	1.167E-03
23	1.7216	313.0	2.903	1.260E+07	3.445E+04	3.720E+01	1.162E-03
24	1.7092	312.8	2.903	1.252E+07	3.434E+04	3.681E+01	1.158E-03
25	1.6851	311.9	2.902	1.240E+07	3.411E+04	3.559E+01	1.135E-03
26	1.6582	311.1	2.902	1.225E+07	3.383E+04	3.432E+01	1.112E-03
27	1.6327	310.7	2.899	1.210E+07	3.351E+04	3.305E+01	1.085E-03
28	1.6099	310.5	2.899	1.195E+07	3.324E+04	3.213E+01	1.069E-03
29	1.5899	310.3	2.899	1.181E+07	3.302E+04	3.137E+01	1.058E-03
30	1.5755	310.1	2.901	1.170E+07	3.288E+04	3.086E+01	1.051E-03
31	1.5651	310.3	2.900	1.162E+07	3.271E+04	3.039E+01	1.042E-03
32	1.5513	310.3	2.900	1.152E+07	3.258E+04	3.008E+01	1.040E-03
33	1.5382	310.0	2.900	1.144E+07	3.245E+04	2.949E+01	1.029E-03
34	1.5196	310.1	2.899	1.130E+07	3.220E+04	2.881E+01	1.017E-03
35	1.5031	310.3	2.899	1.116E+07	3.202E+04	2.847E+01	1.015E-03
36	1.4844	310.5	2.898	1.102E+07	3.169E+04	2.732E+01	9.857E-04
37	1.4638	312.1	2.898	1.079E+07	3.132E+04	2.688E+01	9.840E-04
38	1.4507	312.6	2.898	1.066E+07	3.102E+04	2.593E+01	9.574E-04
39	1.4376	312.8	2.897	1.056E+07	3.089E+04	2.576E+01	9.594E-04
40	1.4079	313.0	2.896	1.034E+07	3.051E+04	2.471E+01	9.388E-04
41	1.3907	313.4	2.895	1.020E+07	3.025E+04	2.400E+01	9.222E-04
42	1.3590	313.0	2.895	9.990E+06	2.987E+04	2.266E+01	8.907E-04
43	1.3224	312.8	2.892	9.742E+06	2.938E+04	2.098E+01	8.456E-04
44	1.2804	312.8	2.892	9.433E+06	2.883E+04	1.922E+01	8.001E-04
45	1.2652	314.5	2.893	9.241E+06	2.854E+04	1.900E+01	8.013E-04
46	1.2383	314.5	2.891	9.054E+06	2.822E+04	1.812E+01	7.795E-04
47	1.2245	315.1	2.892	8.925E+06	2.799E+04	1.756E+01	7.645E-04
48	1.2038	315.1	2.890	8.785E+06	2.767E+04	1.644E+01	7.265E-04
49	1.1597	315.3	2.888	8.461E+06	2.711E+04	1.483E+01	6.795E-04
50	1.1307	316.2	2.888	8.217E+06	2.669E+04	1.395E+01	6.553E-04
51	1.0845	315.6	2.885	7.911E+06	2.620E+04	1.244E+01	6.080E-04
52	1.0680	316.8	2.888	7.740E+06	2.594E+04	1.205E+01	5.992E-04
53	1.0666	321.5	2.888	7.563E+06	2.550E+04	1.193E+01	5.938E-04
54	1.0590	320.6	2.886	7.546E+06	2.546E+04	1.146E+01	5.743E-04
55	1.0459	320.0	2.886	7.473E+06	2.539E+04	1.127E+01	5.715E-04

NSWC TR 79-153

TABLE A-4 SKIN FRICTION DATA LISTING

N	PO*10-5 (N/M2)	TO (DEG.K)	M	RE (1/M)	RETH	TAUW (N/M2)	CF
RUN NO.	822212	K =	.1245 CM	MDOT =	.1465 KG/M2S		
56	1.0397	317.0	2.885	7.538E+06	2.559F+04	1.110E+01	5.657E-04
57	1.0321	319.6	2.886	7.388E+06	2.525E+04	1.068E+01	5.490E-04
58	1.0321	319.6	2.886	7.388E+06	2.526E+04	1.078E+01	5.540E-04
59	1.0321	319.6	2.886	7.388E+06	2.527E+04	1.083E+01	5.565E-04
60	1.0321	319.6	2.886	7.387E+06	2.525E+04	1.071E+01	5.504E-04
61	1.0321	319.8	2.886	7.380E+06	2.521E+04	1.058E+01	5.441E-04
62	1.0287	319.6	2.886	7.364E+06	2.518E+04	1.044E+01	5.382E-04
63	1.0259	317.7	2.886	7.409E+06	2.536E+04	1.061E+01	5.484E-04
64	1.0184	319.4	2.884	7.302E+06	2.511E+04	1.032E+01	5.366E-04
65	1.0053	319.2	2.884	7.217E+06	2.498E+04	9.925E+00	5.227E-04
66	.9873	319.1	2.883	7.098E+06	2.481E+04	9.486E+00	5.083E-04
67	.9742	319.1	2.882	7.007E+06	2.467E+04	9.144E+00	4.962E-04
68	.9598	319.2	2.882	6.898E+06	2.444E+04	8.388E+00	4.620E-04
69	.9418	319.2	2.881	6.773E+06	2.426E+04	8.022E+00	4.498E-04
70	.9246	319.1	2.880	6.658E+06	2.407E+04	7.461E+00	4.259E-04
71	.9087	319.2	2.880	6.539E+06	2.389E+04	7.071E+00	4.105E-04
72	.8943	319.2	2.878	6.440E+06	2.377E+04	6.900E+00	4.066E-04
73	.8756	319.2	2.877	6.310E+06	2.355E+04	6.314E+00	3.796E-04
74	.8598	319.4	2.876	6.192E+06	2.334E+04	5.778E+00	3.536E-04
75	.8425	319.2	2.876	6.075E+06	2.319E+04	5.485E+00	3.424E-04
76	.8205	319.4	2.874	5.917E+06	2.297E+04	5.119E+00	3.276E-04
77	.8046	319.4	2.872	5.809E+06	2.277E+04	4.607E+00	3.001E-04
78	.7881	319.6	2.871	5.685E+06	2.262E+04	4.411E+00	2.933E-04
79	.7722	319.6	2.869	5.577E+06	2.243E+04	3.923E+00	2.658E-04
80	.7557	319.8	2.869	5.452E+06	2.227E+04	3.679E 00	2.548E-04
81	.7033	319.6	2.863	5.097E+06	2.179E+04	2.972E+00	2.199E-04

DISTRIBUTION

NAVY

Commander
Naval Sea Systems Command Headquarters
ATTN: SEA-003
SEA-05R
SEA-9961
SEA-62R41

2

Department of the Navy
Washington, DC 20362

Commander
Naval Air Systems Command Headquarters
ATTN: AIR-03B
AIR-03E
AIR-03P2
AIR-320
AIR-320C
AIR-5301
AIR-310
AIR-950D

2

Department of the Navy
Washington, DC 20361

Chief of Naval Research
ATTN: Mr. Morton Cooper, Code 430B
Technical Library, Code ONR-715
800 North Quincy Street
Arlington, VA 22217

2

Commander
David W. Taylor Naval Ship Research and Development Center
ATTN: Aerodynamics Library (522.3)
Bethesda, MD 20084

DISTRIBUTION (CONT)

Commander
Naval Weapons Center
ATTN: Technical Library
Dr. L. H. Smith
R. W. Van Aken
China Lake, CA 93555

Commanding Officer
Naval Research Laboratory
ATTN: Library (2620)
Washington, DC 20375

2

Commander
Pacific Missile Test Center
ATTN: Technical Library
Point Mugu, CA 93042

Director
Strategic Systems Project Office
ATTN: NSP-272
NSP-43
Department of the Navy
Washington, DC 20376

Commander
Naval Air Development Center
ATTN: Code 8131
Warminster, PA 18974

Commander
Naval Material Command
ATTN: MAT-08T1
MAT-08T2
MAT-08T22
Washington, DC 20360

Commanding Officer
Naval Ordnance Station
ATTN: Technical Library
Indian Head, MD 20640

ARMY

Army Material Command Headquarters
ATTN: Technical Library
5001 Eisenhower Avenue
Alexandria, VA 22333

DISTRIBUTION (CONT)

Director
USA Ballistic Research Laboratories
ATTN: DRDAR-TSB (Technical Library Division)
DRDAR-BLL
Aberdeen Proving Ground, MD 21005

Commanding Officer
Harry Diamond Laboratories
ATTN: Scientific and Technical Information Office
2800 Powder Mill Road
Adelphi, MD 20783

Commander
U.S. Army Missile Research and Development Command
ATTN: DRDMI-TB Scientific Information Center
Mr. R. A. Deep, DRDMI-TDK
Redstone Arsenal, AL 35809

U.S. Army Ballistic Missile Defense Agency
ATTN: Dr. Sidney Alexander
1100 Commonwealth Building
1320 Wilson Boulevard
Arlington, VA 22209

Commander
U.S. Army Armament Research and Development Command
ATTN: Mr. A. A. Loeb, DRDAR-LCA-FB
Picatinny Arsenal
Dover, NJ 07801

Commander
U.S. Army Research Office
ATTN: DRXRO (Technical Library)
P.O. Box 12211
Research Triangle Park, NC 27709

Director
Ballistic Missile Defense Advanced Technology Center
ATTN: Technical Library
P.O. Box 1500
Huntsville, AL 35807

AIR FORCE

Air Force Office of Scientific Research Library (AFOSE Library)
1400 Wilson Boulevard
Arlington, VA 22209

DISTRIBUTION (CONT)

Air Force Systems Command Headquarters Library (DPSL)
Andrews Air Force Base, MD 20334

Commander
Space and Missile Systems Organization
ATTN: Technical Library
Los Angeles Air Force Station
P.O. Box 92960
World Way Postal Center, CA 90009

Headquarters Arnold Engineering Development Center
ATTN: Arnold Center, Library
Arnold Air Force Station, TN 37389

2

von Karman Gas Dynamics Facility
Sverdrup/ARL, Incorporated
Arnold Air Force Station, TN 37388

Department of Aeronautics
DFAN
USAF Academy, CO 80840

Commanding Officer
U.S. Air Force Weapons Laboratory
ATTN: WLRP
Dr. J. Walsh
Technical Library (SUL)
Kirtland Air Force Base
Albuquerque, NM 87117

Air Force Systems Command
Air Force Flight Dynamics Laboratory
ATTN: Aeromechanics Division (FX) Technical Library
Wright Patterson Air Force Base, OH 45433

Air Force Armament Test Laboratory
ATTN: C. Butler (DLM1)
Technical Library
Eglin Air Force Base, FL 32542

NASA

Ames Research Center
National Aeronautics and Space Administration
ATTN: Technical Information Division (AT)
Moffett Field, CA 94035

DISTRIBUTION (CONT)

Langley Research Center
National Aeronautics and Space Administration
ATTN: Technical Library Braner (4230, MS 185)
Langley Station
Hampton, VA 23665

Lewis Research Center
National Aeronautics and Space Administration
ATTN: Library - Mail Stop 60-3
Library Branch (1950, MS 60-3)
21000 Brookpark Road
Cleveland, OH 44135

George C. Marshall Space Flight Center
National Aeronautics and Space Administration
ATTN: Central Library
Redstone Scientific Information Center
Marshall Space Flight
Center, AL 35812

National Aeronautics and Space Administration
ATTN: Technical Library (KSS-10)
Washington, DC 20546

OTHER FEDERAL GOVERNMENT

National Bureau of Standards Library
E01 Administration Bldg.
Washington, DC 20234

Los Alamos Scientific Laboratory
ATTN: Report Library
P.O. Box 1663
Los Alamos, NM 87544

Defense Documentation Center
Cameron Station
Alexandria, VA 22314

12

Defense Nuclear Agency
ATTN: Technical Library
Washington, DC 20305

Defense Advanced Research Projects Agency
ATTN: Technical Library
1400 Wilson Boulevard
Arlington, VA 22209

DISTRIBUTION (CONT)

UNIVERSITY

Aerospace Engineering Program
University of Alabama
ATTN: Prof. W. K. Rey, Chrm.
P.O. Box 6307
University, AL 35486

AME Department
University of Arizona
ATTN: Dr. L. B. Scott, Jr.
Tucson, AZ 85719

Auburn University
Department of Aerospace Engineering
Auburn, AL 36830

Brown University
Division of Engineering
ATTN: Dr. M. Sibulkin Library
Division of Engineering
Providence, RI 02912

California Institute of Technology
ATTN: Graduate Aeronautical Laboratories 205 Library
Dr. D. E. Coles, 306 Karman Lab.
Dr. A. Roshko
Pasadena, CA 91125

Dr. John D. Nicolaidis, Head Aero Engineering Dept.
California State Polytechnic University
San Luis Obispo, CA 93401

University of California
ATTN: Dr. M. Holt
Dr. A. K. Oppenheim, Div. of Aeronautical Sciences
Berkeley, CA 94720

Department of Aerospace Engineering
ATTN: Dr. John Laufer
University of Southern California
University Park
Los Angeles, CA 90007

DISTRIBUTION (CONT)

University of California - San Diego
Department of Aerospace and Mechanical Engineering Sciences
ATTN: Dr. P. A. Libby
LaJolla, CA 92037

Case Western Reserve University
ATTN: Dr. E. Reshotko
3306 Clarendon Road
Cleveland, OH 44118

The Catholic University of America
ATTN: Dr. C. C. Chang
Dr. Paul K. Chang, Mechanical Engr. Dept.
Dr. M. J. Casarella, Mechanical Engr. Dept.
Washington, DC 20017

University of Cincinnati
ATTN: Department of Aerospace Engineering
Dr. Arnold Polak
Cincinnati, OH 45221

Department of Aerospace Engineering Sciences
University of Colorado
Boulder, CO 80301

Cornell University
Graduate School of Aero. Engineering
ATTN: Dr. S. F. Shen
Prof. F. K. Moore
Ithaca, NY 14850

University of Delaware
Mechanical and Aeronautical Engineering Dept.
ATTN: Dr. James E. Danberg
Newark, DE 19711

George Washington University
ATTN: Library
2130 H. Street NW
Washington, DC 20052

Georgia Institute of Technology
ATTN: Dr. Arnold L. Ducoffe Aerospace Engr. Dept.
225 North Avenue, NW
Atlanta, GA 30332

DISTRIBUTION (CONT)

Technical Reports Collection
Gordon McKay Library
Harvard University
Div. of Engineering and Applied Physics
Pierce Hall, Oxford Street
Cambridge, MA 02138

Illinois Institute of Technology
ATTN: Dr. M. V. Morkovin
Prof. A. A. Fejer, MAE Dept.
3300 South Federal
Chicago, IL 60616

University of Illinois
ATTN: Dr. H. H. Korst
Dr. R. A. White
Dr. H. H. Hilton
Dr. K. R. Sivier
Urbana, IL 61801

Iowa State University
ATTN: Aerospace Engineering Department
Ames, IA 50010

The Johns Hopkins University
Mechanics Department
ATTN: Prof. S. Corrsin
Baltimore, MD 21218

University of Kentucky
Wenner-Gren Aero. Lab.
Lexington, KY 40506

Department of Aero. Engineering ME 106
Louisiana State University
ATTN: Dr. P. H. Miller
Baton Rouge, LA 70803

University of Maryland
ATTN: Dr. S. I. Pai
Dr. Redfield W. Allen
Dr. W. L. Melnik
Dr. John D. Anderson, Jr.
Dr. A. E. Winkelmann
Dr. E. Jones
Engineering and Physical Sciences Library
College Park, MD 20742

DISTRIBUTION (CONT)

Massachusetts Institute of Technology

ATTN: Prof. J. Baron, Dept. of Aero. and Astro., Rm. 37-461
Prof. A. H. Shapiro, Institute Professor
Aero. Engineering Library
Prof. Ronald F. Probstein
Dr. E. E. Covert, Aerophysics Laboratory
Cambridge, MA 02139

Michigan State University Library

ATTN: Documents Dept.
East Lansing, MI 48823

University of Michigan

ATTN: Dr. M. Schel
R. M. Howe, Dept. of Aero. Engineering
Engineering Library
Aerospace Engineering Library Acquisitions Section, Serials Div.
Ann Arbor, MI 48105

Mississippi State University

Department of Aerophysics and Aerospace Engineering
P.O. Drawer A
State College, MS 39762

Superintendent

U.S. Naval Academy
ATTN: Director of Research Nimitz Library
Dr. J. Gillerlain
Annapolis, MD 21402

Superintendent

U.S. Naval Postgraduate School
ATTN: Technical Reports Section
Monterey, CA 93940

New York University

Aerospace and Energetics Lab
ATTN: Prof. V. Zakkay
Engineering and
Science Library
Merrick and Stewart Avenues
Westbury, L. I., NY 11590

North Carolina State University

ATTN: Dr. H. A. Hassan, Dept. of Mech. and Aero Engineering
Raleigh, NC 27607

DISTRIBUTION (CONT)

J. H. Hill Library
North Carolina State University
P.O. Box 5007
Raleigh, NC 27607

Northwestern University
Technological Institute
ATTN: Department of Mech. Engr. Library
Evanston, IL 60201

Univ. of Notre Dame
Dept. of Aerospace and Mechanical Engineering
Notre Dame, IN 46556

Ohio State University
ATTN: Aero. Civil Library
Prof. J. D. Lee
Dr. S. L. Petrie
2036 Neil Avenue
Columbus, OH 43210

Ohio State University Libraries
Documents Division
1858 Neil Avenue
Columbus, OH 43210

Oklahoma State University
Office of Engineering Research
Stillwater, OK 74074

Department of Aerospace Engineering
Room 233 Hammond Building
The Pennsylvania State University
University Park, PA 16802

Pennsylvania State University Library
Documents Section
University Park, PA 16802

Polytechnic Institute of New York
Graduate Center Library
ATTN: Dr. R. J. Cresci
Route 11
Farmingdale, L. I. NY 11735

Polytechnic Institute of New York
ATTN: Reference Department
Spicer Library
333 Jay Street
Brooklyn, NY 11201

DISTRIBUTION (CONT)

Bevier Engineering Library
ATTN: Librarian
126 Benedum Hall
University of Pittsburgh
Pittsburgh, PA 15213

Princeton University
James Forrestal Research Center
ATTN: Prof. S. Bogdonoff
Gas Dynamics Laboratory
Princeton, NJ 08540

Purdue University
School of Aeronautical and Engineering Sciences
ATTN: Library
Dr. P. S. Lykoudis, Dept. of Aero. Engr.
Lafayette, IN 47901

Rensselaer Polytechnic Institute
ATTN: Dept. of Aeronautical Engineering and Astronautics
Dr. Robert E. Duffy
Troy, NY 12181

Rutgers - The State University
ATTN: Dr. R. H. Page, Dept. of Mech. and Aero. Engr.
University Heights Campus
New Brunswick, NJ 08903

Stanford University
ATTN: Librarian, Dept. of Aeronautics and Astronautics
Dr. R. J. Moffat
Stanford, CA 94305

Stevens Institute of Technology
ATTN: Mech. Engr. Dept. Library
Hoboken, NJ 07030

The University of Texas at Austin
ATTN: Director Applied Research Laboratories
P.O. Box 8029
Austin, TX 78712

Documents Department
Virginia Polytechnic Institute and State University
ATTN: Carol M. Newman, Library
Blacksburg, VA 24061

DISTRIBUTION (CONT)

University of Virginia
ATTN: Alderman Library Science Reference Div.
Charlottesville, VA 22901

University of Washington
ATTN: Engineering Library
Dept. of Aeronautics and Astronautics
Prof. R. E. Street
Prof. A. Hertzberg
Dr. M. E. Childs
Seattle, WA 98105

West Virginia University
ATTN: Library
Morgantown, WV 26506

Federal Reports Center
University of Wisconsin
462 Mechanical Engr. Bldg.
1513 University Avenue
Madison, WI 53706

INDUSTRY

Acurex Corporation
ATTN: Dr. L. J. Alpinieri
Dr. C. Nardo
M. Abbet
485 Clyde Avenue
Mountain View, CA 94040

Aerojet Services Co.
ATTN: T. G. Lee
P.O. Box 13618
Sacramento, CA 95813

Aeronautical Research Associates of Princeton
ATTN: Dr. C. DuP. Donaldson
50 Washington Road
Princeton, NJ 08540

AVCO-Everett Research Laboratory, Inc.
ATTN: Library
Dr. George Sutton
2385 Revere Beach Parkway
Everett, MA 02149

DISTRIBUTION (CONT)

AVCO, Research Systems Group
ATTN: E. E. H. Schurmann
V. D. Cristina
N. A. Thyson
201 Lowell Street
Wilmington, MA 01887

Fairchild Republic Co.
Fairchild Industries, Inc., Complin St.
ATTN: Engineering Library
Farmingdale, NY 11735

CONVAIR Division, General Dynamics Corporation
Library and Information Services
P.O. Box 80877
San Diego, CA 92138

General Dynamics Corporation
ATTN: Research Library 2246
P.O. Box 748
Fort Worth, TX 76101

General Dynamics Corporation
Pomona Division, P.O. Box 2507
ATTN: Division Library Mail Zone 6-20
Pomona, CA 91766

General Electric Company
Re-Entry and Environmental Systems Division
ATTN: MSD Library
Dr. J. D. Stewart
D. Nestler
Dr. B. McGuire
B. Neff
W. Daskin
P.O. Box 7722
Philadelphia, PA 19101

General Electric Research and Development Center
The Whitney Library
The Knolls, K-1
P.O. Box 8
Schenectady, NY 12301

DISTRIBUTION (CONT)

General Research Corporation
ATTN: Technical Info. Officer
5383 Hollister Avenue
P.O. Box 3587
Santa Barbara, CA 93105

Grumman Aerospace Corporation
ATTN: Dr. R. A. Scheuing
Mr. H. B. Hopkins
Bethpage, L.I., NY 11714

HERCULES Incorporated
Allegany Aerospace Division
ATTN: Mrs. Louise E. Derrick, Librarian
P.O. Box 210
Cumberland, MD 21502

Hughes Aircraft Company
ATTN: Co. Tech. Doc. Ctr., MS 6/E110
Centinela and Teale Streets
Culver City, CA 90230

Institute for Defense Analyses
ATTN: Classified Library
400 Army-Navy Drive
Arlington, VA 22202

Kaman Nuclear
ATTN: F. Barbera
J. Forkis
D. Elder
J. Harper
P. Wells
1700 Garden of the Gods Road
Colorado Springs, CO 80907

Kaman Science Corporation
Avidyne Division
ATTN: Dr. J. R. Ruetenik
83 Second Avenue
Burlington, MA 01803

Lockheed Aircraft Corporation
Vice President and Chief Scientist Dept. 03-01
ATTN: Dr. Ronald Smelt
P.O. Box 551
Burbank, CA 91503

DISTRIBUTION (CONT)

Lockheed-California Company
ATTN: Central Library
Dept. 84-40
Bldg. 170,
PLT. B-1
Burbank, CA 91503

Lockheed Missiles and Space Company, Inc.
ATTN: Technical Information Center
Dr. R. P. Caren
3251 Hanover Street
Palo Alto, CA 94304

Lockheed Missiles and Space Company, Inc.
Lockheed Aircraft Corporation
ATTN: G. T. Chrusciel
Dr. L. E. Ericsson
L. Hull
J. P. Reding
C. Lee
B. Smith
B. Coleman
R. Gunther
C. Thompson
C. Louie

P.O. Box 504
Sunnyvale, CA 94088

Martin Marietta Corporation
ATTN: Science-Technology Library (Mail No. 398)
P.O. Box 988
Baltimore, MD 21203

Martin Marietta Corporation
Orlando Division
ATTN: Technical Library
P.O. Box 5837
Orlando, FL 32855

M.I.T. Lincoln Laboratory
ATTN: Library A-082
Dr. S. Edelberg
P.O. Box 73
Lexington, MA 02173

DISTRIBUTION (CONT)

McDonnell Aircraft Company
McDonnell Douglas Corporation
Research and Engineering Library
Dept. 209, Bldg. 33
P.O. Box 516
St. Louis, MI 63166

McDonnell Douglas Astronautics Company
Space Systems Center
ATTN: A2-260 Library
Dr. J. S. Murphy, A-830
Mr. W. H. Branch, Director
A3-339 Library
5301 Bolsa Avenue
Huntington Beach, CA 92647

Nielson Engineering and Research, Incorporated
ATTN: Dr. J. N Nielson
510 Clyde Avenue
Mountain View, CA 94043

Northrop Corporation
ATTN: Technical Info. 3343-32
P. F. Jensen
3901 West Broadway
Hawthorne, CA 90250

Raytheon Company
Missile Systems Division
ATTN: H. H. Roscoe
Hartwell Road
Bedford, MA 01730

Columbus Aircraft Division
Rockwell International Corporation
Engineering Data Services
4300 E. Fifth Avenue
Columbus, OH 43216

Rockwell International
ATTN: LAD Library, Dept. 299
International Airport
Technical Information Center (BA08)
Los Angeles, CA 90009

DISTRIBUTION (CONT)

Sandia Laboratories
ATTN: Mr. K. Goin, 5217
Mrs. B. R. Allen, Div. 3421
Mr. R. Maydew
Mr. D. McBride
Dr. D. Reda
Albuquerque, NM 87115

Science Application, Incorporated
Missile Technology Division
ATTN: L. A. Cassel
201 West Dyer Road, Unit B
Santa Ana, CA 94025

Stanford Research Institute
ATTN: Library
333 Ravenswood Avenue
Menlo Park, CA 94025

The Aerospace Corporation
ATTN: Dr. W. R. Warren, Jr., 130/691
D. Nowlan
H. Diner
Col. W. Goldberg
Capt. Chambers
Col. McCormick
P.O. Box 92957
Los Angeles, CA 90009

The Boeing Company
ATTN: Aerospace Library
P.O. Box 3999
Seattle, WA 98124

The Johns Hopkins University
Applied Physics Laboratory
ATTN: Document Library
Dr. F. K. Hill
Dr. L. L. Cronvich
Dr. L. Glover
Dr. R. E. Lee
Dr. J. Wagner
Johns Hopkins Road
Laurel, MD 30810

The Rand Corporation
ATTN: Library - D
1700 Main Street
Santa Monica, CA 90406

NSWC TR 79-153

DISTRIBUTION (CONT)

TRW Incorporated
ATTN: Technical Library - Document Acquisitions
1 Space Park
Redondo Beach, CA 90278

United Technologies Corporation
United Technologies Research Ctr.
ATTN: Library
Dr. William M. Foley
Dr. M. J. Werle
400 Main St.
East Hartford, CT 06108

Vought Corporation
ATTN: MDS-T-Library
J. M. Cooksey
P.O. Box 225967
Dallas, TX 75265