

AD-A077 897

TRANSPORTATION SYSTEMS CENTER CAMBRIDGE MA
FAA/NASA PROCEEDINGS WORKSHOP ON WAKE VORTEX ALLEVIATION AND AV--ETC(U)
OCT 79 W D WOOD

F/G 1/2

UNCLASSIFIED

TSC-FAA-79-77

FAA-RD-79-105

NL

1 OF 4

AD
A077897

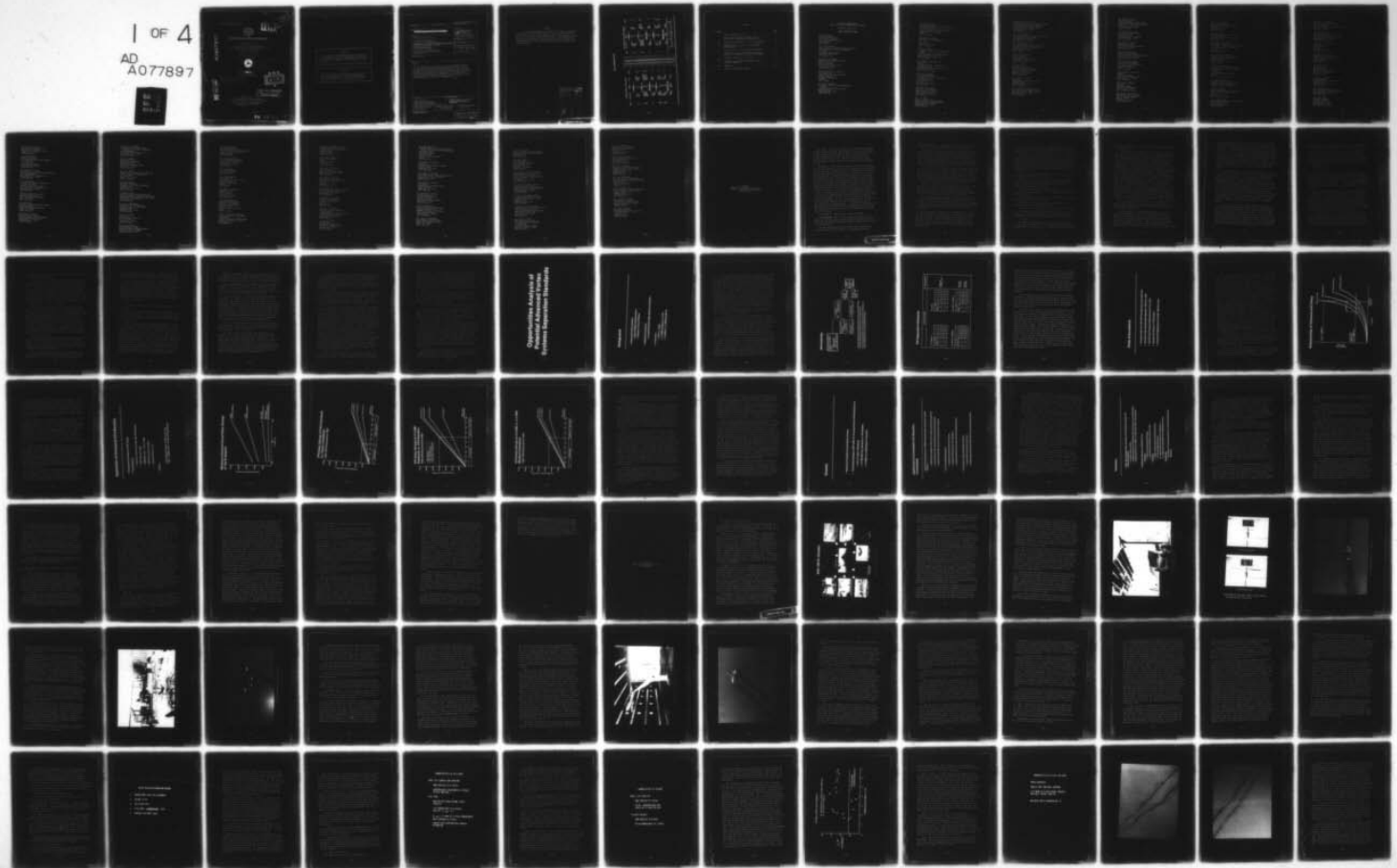

REPORT NO. FAA-RD-79-105

LEVEL

12

6
FAA/NASA
PROCEEDINGS
WORKSHOP
ON
WAKE VORTEX ALLEVIATION AND AVOIDANCE

Presented at the
U.S. DEPARTMENT OF TRANSPORTATION
Research and Special Programs Administration
Transportation Systems Center
Cambridge, MA 02142,
NOVEMBER 28-29, 1978,



10
William D. Wood

12 338

11
OCT 1979

WORKSHOP PROCEEDINGS

14
TSC-FAA-79-77

DDC
RECEIVED
DEC 10 1979
A

DISTRIBUTION STATEMENT A

Approved for public release;
Distribution Unlimited

Prepared for
U.S. DEPARTMENT OF TRANSPORTATION
Systems Research and Development Service
Federal Aviation Administration
Washington, DC 20590

AD A 077897

DDC FILE COPY

407 082

79 12 10 008

FAA/NASA PROCEEDINGS: WORKSHOP ON WAKE

NOTICE

This document is disseminated under the sponsorship of the Department of Transportation in the interest of information exchange. The United States Government assumes no liability for its contents or use thereof.

NOTICE

The United States Government does not endorse products or manufacturers. Trade or manufacturers' names appear herein solely because they are considered essential to the object of this report.

PREFACE

These Proceedings were taken from the tape recording of the speeches with only minor editing. In some cases it was not possible to obtain the illustrations used by some speakers, nevertheless their references to motion pictures or projectuals have been retained, for to have edited them out would have unduly distorted the text.

Accession For	
NTIS GRA&I	<input checked="" type="checkbox"/>
DDC TAB	<input type="checkbox"/>
Unannounced	<input type="checkbox"/>
Justification	
By _____	
Distribution/	
Availability Codes	
Dist	Available and/or special
A	

METRIC CONVERSION FACTORS

Approximate Conversions to Metric Measures				Approximate Conversions from Metric Measures			
Symbol	When You Know	Multiply by	To Find	Symbol	When You Know	Multiply by	To Find
LENGTH							
in	inches	2.5	centimeters	mm	millimeters	0.04	inches
ft	feet	30	centimeters	cm	centimeters	0.4	inches
yd	yards	0.9	meters	m	meters	1.1	yards
mi	miles	1.6	kilometers	km	kilometers	0.6	miles
AREA							
sq in	square inches	6.5	square centimeters	sq cm	square centimeters	0.16	square inches
sq ft	square feet	0.09	square meters	sq m	square meters	1.2	square yards
sq yd	square yards	0.8	square meters	sq km	square kilometers	0.4	square miles
sq mi	square miles	2.6	square kilometers	ha	hectares (10,000 m ²)	2.5	acres
MASS (weight)							
oz	ounces	28	grams	g	grams	0.035	ounces
lb	pounds	0.45	kilograms	kg	kilograms	2.2	pounds
	short tons (2000 lb)	0.9	tonnes	t	tonnes	1.1	short tons
VOLUME							
teaspoon	teaspoons	5	milliliters	ml	milliliters	0.03	fluid ounces
tablespoon	tablespoons	15	milliliters	ml	milliliters	2.1	fluid ounces
cup	fluid ounces	30	milliliters	l	liters	1.06	quarts
cup	cup	0.24	liters	l	liters	0.26	gallons
quart	quarts	0.95	liters	l	liters	36	cubic feet
gallon	gallons	3.8	liters	m ³	cubic meters	1.3	cubic yards
cu ft	cubic feet	0.03	cubic meters	m ³	cubic meters		
cu yd	cubic yards	0.76	cubic meters				
TEMPERATURE (exact)							
°F	Fahrenheit temperature	5/9 (after subtracting 32)	Celsius temperature	°C	Celsius temperature	9/5 (then add 32)	Fahrenheit temperature

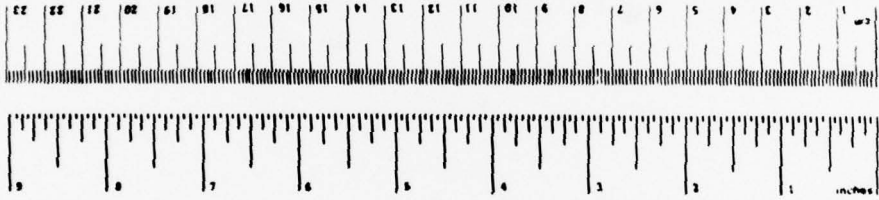

CONTENTS

<u>SESSION</u>		<u>Page</u>
	FINAL ATTENDANCE LIST.....	vii
I	WAKE VORTICES AND THE AIRSPACE SYSTEM - A DISCUSSION OF POTENTIAL OPPORTUNITIES.....	1-1
II	WAKE VORTEX ALLEVIATION - THE NASA PROGRAM.....	2-1
III	PROGRAMS AND ACTIVITIES OF THE AIRFRAME MANUFACTURERS.....	3-1
IV	FAA ACTIVITIES IN DETECTION AND AVOIDANCE.....	4-1
V	OPERATIONS, CERTIFICATION AND REGULATORY ASPECTS OF VORTEX ALLEVIATION AND AVOIDANCE.....	5-1
VI	WORKSHOP ORGANIZATION DISCUSSION.....	6-1
VII	STATEMENTS OF INTERESTED MEMBERS OF THE AVIATION COMMUNITY.....	7-1
VIII	WORKSHOPS.....	8-1
IX	REPORTS BY WORKSHOP CHAIRMEN.....	9-1

FAA/NASA WORKSHOP ON
WAKE VORTEX ALLEVIATION AND AVOIDANCE

November 28-29, 1978

FINAL ATTENDANCE LIST

Mr. W. Aardoom
Aerospace Engineer
Air Traffic Services
PB 7601, Schiphol Center
Netherlands
020-5162252

Mr. Louis Achitoff
Chief, Aviation Technical Services Div.
Port Authority of New York and New
Jersey
One World Trade Center
New York, NY 10024
(212) 466-7472

Mr. Frank A. Amodeo
Member of the Technical Staff
Mitre Corporation
Metrek Division
1820 Dolley Madison Blvd.
McLean, VA 22102
(703) 827-6019

Mr. Hans Christian Andersen
ATCO/Inspector
Directorate of Civil Aviation
Gammel Kongevej 60
DK-1850 Copenhagen V
Denmark
(01) 314848

Mr. James Andersen
Director, Office of Air and Marine
Systems
Transportation Systems Center
Kendall Square
Cambridge, MA 02142
(617) 494-2467

Mr. John Aspinall
ATC Procedures Specialist Supervisor
Transport Canada
Air Traffic Services Headquarters
ATPP, Transport Canada
Ottawa, Ontario K1A 0N8
Canada
(613) 996-7394

Mr. Marvin R. Barber
Wake Vortex Program Manager
NASA/DFRC
P.O. Box 223
Edwards, CA 93523
(805) 258-3311

Mr. Gene Barlow
Terminal Operations and Procedures
Branch
Federal Aviation Administration
800 Independence Ave, S.W.
Washington, DC 20591
(202) 426-8532

Mr. Alfred J. Bedard, Jr.
Physicist
National Oceanic & Atmospheric
Administration
Wave Propagation Laboratory, R45X7
Boulder, CO 80302
(303) 499-1000, x6508

Dr. Alan J. Bilanin
Head, Aeromechanics
Aeronautical Research Associates
of Princeton
50 Washington Road
P.O. Box 1222
Princeton, NJ 08540
(609) 452-2950

Mr. Richard E. Black
Director, Technologies
Douglas Aircraft Company
3855 Lakewood Blvd.
Long Beach, CA 90846
(213) 593-2025

Mr. C.L. Blake
Chief, Airport Division, SRDS
Federal Aviation Administration
2100 Second Street, S.W.
Washington, DC 20590
(202) 426-3664

Mr. Neal A. Blake, AED-2
Acting Deputy Associate Administrator
for Engineering & Development
Federal Aviation Administration
800 Independence Avenue, S.W.
Washington, DC 20591
(202) 426-8332

Mr. Frank B. Brady
Director, National Airspace Engineering
Air Transport Association
1709 New York Avenue, N.W.
Washington, DC 20006

Mr. Edmund Bromley, Jr.
Assistant Chief, Airport Division
Federal Aviation Administration
2100 Second Street, S.W.
Washington, DC 20590
(202) 426-3664

Mr. Clinton E. Brown
Chief Scientist
Hydronautics Inc.
7210 Pindell School Road
Laurel, MD 20810
(301) 776-7454

Mr. Ray Brown
Operations Engineer
Pan American World Airways
JFK International Airport
Hangar 14, Room 366
Jamaica, NY 11430
(212) 632-5440

Dr. David C. Burnham
Physicist
Transportation Systems Center
Kendall Square
Cambridge, MA 02142
(617) 494-2134

Mr. Jerold M. Chavkin, AED-3
Federal Aviation Administration
800 Independence Avenue, S.W.
Washington, DC 20591
(202) 426-9330

Mr. Myron E. Clark
Project Manager
Federal Aviation Administration
Wind Shear & Wake Vortex Branch
2100 Second Street, S.W.
Washington, DC 20590
(202) 426-9350

Mr. William G. Codner
Civil Air Attache (ATS)
British Embassy
3100 Massachusetts Avenue
Washington, DC 20008
(202) 462-1340

Mr. Delwin R. Croom
Aerospace Engineer
NASA Langley Research Center
Hampton, VA 23665
(804) 827-3611

Mr. Hector Daiutolo
Program Manager, NAFEC
Federal Aviation Administration
Atlantic City, NJ 08405
(609) 641-8200, x2283

Capt. Joseph P. Davies
Air Safety Coordinator
Airline Pilots Association
1223 Robin Hood Drive
Elgin, IL 60120
(312) 741-1223

Mr. Jean Paul Deneuve
Engineer
Embassy of France
2164 Florida Avenue, N.W.
Washington, DC 20008
(202) 328-4634

Mr. Charles DiMarzio
Engineer
Raytheon Company
430 Boston Post Road
Wayland, MA 01778
(617) 358-2721, x5251

Mr. Robert O. Dodson, Jr.
Senior Specialist Engineer
Boeing Wichita Company
3801 S. Oliver
Wichita, KS 67210
(316) 687-3671

Mr. R. Earl Dunham
Aerospace Technologist
NASA Langley Research Center
Langley Field
Hampton, VA 23665
(804) 827-3274

Mr. Jack Enders
Aeronautic Operating Systems Div.
NASA Headquarters
600 Independence Avenue, S.W.
Washington, DC

Mr. Ralph L. Erwin, Jr.
Engineering Supervisor
Air Traffic Control Systems Analysis
Boeing Commercial Airplane Co.
P.O. Box 3707
Seattle, WA 98124
(206) 655-3471

Mr. Frederick Frankel
Systems Requirements Branch
Transportation Systems Center
Kendall Square
Cambridge, MA 02142
(617) 494-2096

Mr. Jean-Luc Garnier
Ingénieur de l'Aviation Civile
Centre d'Etudes de la Navigation
Aérienne
Orly Sud #205
94542-Orly Aerogares Cedex
France
(1) 707-47-59, ext. 632

Mr. Leo J. Garodz
Program Manager/NAFEC
Federal Aviation Administration
Atlantic City, NJ 08405
(609) 641-8200, x3885/3801

Mr. W.M. Gertsen
Chief, Aerodynamics & Propulsion
Gates Learjet Corporation
Box 7707
Wichita, KS 67277
(316) 722-5640, x431

Mr. Alfred Gessow
Chief, Aerodynamics & Fluid Physics
NASA Headquarters
Washington, DC 20546
(202) 755-2397

Mr. David J. Goldsmith
Advance Technology Engineer
Eastern Airlines
Miami International Airport (MIAEV)
Miami, FL 33148
(305) 873-3663

Mr. Nigel Gregory
Aerodynamics Officer, D.R.D.S.
British Defence Staff
3100 Massachusetts Avenue, N.W.
Washington, DC 20008
(202) 462-1340, x2569

Mr. Roger W. Griswold II
President
Flightcraft Inc.
Box 305
Old Lyme, CT 07371
(203) 434-7736

Dr. Mitchell Grossberg
Engineering Psychologist
Transportation Systems Center
Kendall Square
Cambridge, MA 02142
(617) 494-2259

Dr. Andrew Haines
Group Leader
The Mitre Corporation
Metrek Division
1820 Dolley Madison Blvd.
McLean, VA 22102
(703) 827-6714

Dr. James N. Hallock
Senior Engineer
Transportation Systems Center
Kendall Square
Cambridge, MA 02142
(617) 494-2470

Mr. Edward Hanlon
Federal Aviation Administration
800 Independence Avenue, S.W.
Washington, DC 20591
(202) 426-8634

Mr. Clark Harris
Principal Engineer
Raytheon Company
430 Boston Post Road
Wayland, MA 01778
(617) 358-2721, x5251

Mr. Earl C. Hastings, Jr.
Aerospace Technology
NASA Langley Research Center
Hampton, VA 23665
(804) 827-3621

Mr. Arthur Hecht
Senior Consultant
Aeronautical Research Associates
of Princeton
P.O. Box 1222
50 Washington Road
Princeton, NJ 08540
(609) 452-2950

Mr. Kenneth E. Hodge
Director, Aero. Operating Systems Div.
NASA Headquarters
600 Independence Avenue, S.W.
Washington, DC 20546
(202) 755-2375

Mr. Jack Howell
Assistant Executive Central Air
Safety Chairman
Airline Pilots Association
1625 Massachusetts Avenue, N.W.
Washington, DC 20036
(202) 797-4194

Professor James D. Iversen
Iowa State University
304 Town Engineering Bldg.
Ames, IA 50011
(515) 294-5157

Dr. Dale Jones
Manager, Flight Technical Services
Eastern Airlines
Miami International Airport
Miami, FL 33148
(305) 873-3663

Mr. Philip J. Klass
Senior Avionics Editor
Aviation Week & Space Technology
#425 National Press Bldg.
Washington, DC 20024
(202) 624-7586

Dr. James J. Kramer
Associate Administrator for
Aeronautics & Space Technology
NASA Headquarters
600 Independence Avenue, SW
Washington, DC 20546
(202) 755-2393

Mr. A.N. Kulkarni
Technical Staff
The Mitre Corporation
Metrek Division
1820 Dolley Madison Blvd.
McLean, VA 22102
(703) 827-6260

Mr. J.L. Lundry
Supervisor, Low-Speed Aero Research
Boeing Commercial Airplane Co.
P.O. Box 3707
Seattle, WA 98124
(206) 773-8407

Mr. David Manor
Research Associate
Aerospace Engineering Department
Virginia Tech
Blacksburg, VA 24061
(703) 961-5518

Mr. Mike McCarty
Staff Assistant, Airport Services
National Business Aircraft Association
One Farragut Square South, 11th Floor
Washington, DC 20006
(202) 783-9000

Mr. Ian G. McWilliams
Operations Research Analyst
Transportation Systems Center
Kendall Square
Cambridge, MA 02142
(617) 494-2433

Dr. J.C.S. Meng
Scientist
Science Application, Inc.
P.O. Box 2351
LaJolla, CA 92038
(714) 454-3811

Mr. Nelson Miller
Staff Engineer, NAFEC
Federal Aviation Administration
Atlantic City, NJ 08405
(609) 641-8200, x2020

Mr. William Morges
Operations Inspector
Federal Aviation Administration
Flight Standards Division
Burlington, MA
(617) 836-1334

Mr. L. Homer Mouden
Vice President-Technical
Flight Safety Foundation
5510 Columbia Pike
Arlington, VA 22204
(703) 820-2777

Mr. B.J. Murano
167 School Street
Revere, MA 02151
(617) 289-7095

Mr. Erling Nielsen
ATCO/Inspector
Directorate of Civil Aviation
Gammel Kongevej 60
DK-1850 Copenhagen V
Denmark
(01) 314848

Mr. John W. Perkinson
Manager of ATC
United Airlines
P.O. Box 66100
Chicago, IL 60666
(312) 942-4591

Mr. Desmond Peters
Aviation Safety Bureau
Ministry of Transport
Transport Canada Bldg.
Place-de-Ville
Ottawa, Ontario K1A 0N8
Canada
(613) 995-6917

Mr. S.B. Poritzky, Director
Office of Systems Engineering
Management
Federal Aviation Administration
Washington National Airport
Washington, DC
(202) 426-8332

Dr. David S. Prerau
Systems Requirements Branch
Transportation Systems Center
Kendall Square
Cambridge, MA 02142
(617) 494-2300

Mr. Charles Radgowski
Associate Manager
IITRI
10 W. 35th Street
Chicago, IL
(312) 567-4459

Dr. Vernon J. Rossow
Staff Scientist
NASA Ames Research Center
Moffett Field, CA 94035
(415) 965-6681

Mr. Robert O. Schade
Chief, Flight Research
NASA Langley Research Center
MS 246A
Hampton, VA 26665
(804) 827-2037

Mr. Michael M. Scott
Federal Aviation Administration
800 Independence Ave. S.W.
Washington, DC 20591
(202) 426-8634

Mr. Walter E. Sheehan
Senior Staff Engineer
Lockheed-California Co.
Box 551
Burbank, CA
(805) 272-2106

Mr. David J. Sheftel
Director, Systems Research &
Development
Federal Aviation Administration
2100 Second Street, SW
Washington, DC 20590
(202) 426-3200

Dr. Agam N. Sinha
Group Leader
The Mitre Corporation
1820 Dolley Madison Blvd.
McLean, VA 22102
(703) 827-6410

Mr. Bob Smandych
Superintendent, Special Application
Radar & Display Systems Engineering
Transport Canada
9th Floor-Tower C
Place-de-Ville
Ottawa, Ontario K1A 0N8
Canada
(613) 992-2608

Mr. Edward A. Spitzer
Engineer
Transportation Systems Center
Kendall Square
Cambridge, MA 02142
(617) 494-2088

Mr. Joseph W. Stickle
Assistant Chief, Flight Research Div.
NASA Langley Research Center
Hampton, VA 23665
(804) 827-2037

Mr. Thomas E. Sullivan
Staff Member
Transportation Systems Center
Kendall Square
Cambridge, MA 02142
(617) 494-2134

Mr. William J. Swedish
Systems Engineer
The Mitre Corporation
Metrek Division
1820 Dolley Madison Blvd.
McLean, VA 22101
(703) 827-6260

Mr. J.A. Thelander
Senior Engineer, Aerodynamics
Douglas Aircraft Co.
McDonnell Douglas Corporation
3855 Lakewood Blvd.
Long Beach, CA 90808
(213) 593-6138

Mr. Craig F. Timmerman
Dade County Aviation Dept.
Miami International Airport
Miami, FL 33159
(305) 526-2145

Mr. Guice Tinsley
Chief, Wind Shear & WVAS Branch
Federal Aviation Administration
Washington, DC
(202) 426-9350

Dr. Ivar Tombach
Vice President
Environmental Programs
Aerovironment, Inc.
145 Vista Avenue
Pasadena, CA 91107
(213) 449-4392

Mr. Joseph J. Tymczyszyn, Sr.
Staff Officer, Special Projects
Aircraft Engineering Div.
Federal Aviation Administration
P.O. Box 92007
Los Angeles, CA 90009
(213) 966-6376

Dr. Joseph P. Tymczyszyn, Jr.
Flight Standards Service
Federal Aviation Administration
800 Independence Avenue, SW
Washington, DC 20591
(202) 426-8452

Dr. David Van Meter, Chief
Systems Development Division
Transportation Systems Center
Kendall Square
Cambridge, MA 02142
(617) 494-2646

Mr. Robert W. Wedan, ARD-2
Deputy Director, Systems Research
and Development Service
Federal Aviation Administration
2100 Second Street, SW
Washington, DC 20591
(202) 426-3203

Mr. Lawson C. White
Senior Operations Officer
International Air Transport
Association
100 Sherbrooke St., West
Montreal, Quebec, Canada
(514) 844-6311

Mr. Clive Whitmore
Group Engr. Performance
Lockheed California Co.
P.O. Box 551
Burbank, CA 91520
(213) 847-1259

Mr. Philip Wingrove
Group Engineer, Flight Test
The Boeing Company
P.O. Box 3707
Seattle, WA 98124

Mr. Berl P. Winston
Traffic and Operations Branch
Transportation Systems Center
Kendall Square
Cambridge, MA 02142
(617) 494-2433

Mr. H.W. Withington
Vice President, Engineering
Boeing Commercial Airplane Company
P.O. Box 3707
Seattle, WA 98124
(206) 237-0747

Mr. William D. Wood
Chief, Traffic & Operations Branch
Transportation Systems Center
Kendall Square
Cambridge, MA 02142
(617) 494-2181

Mr. Douglas C. Young
Aeronautical Engineer
NASA Wallops Flight Center
Wallops Island, VA 23337
(804) 824-3411

Mr. Andrew Zalay
Research Specialist
Lockheed Missiles & Space Co.
P.O. Box 1103
Huntsville, AL
(205) 837-1800

SESSION I
WAKE VORTICES AND THE AIRSPACE
SYSTEM - A DISCUSSION OF POTENTIAL
OPPORTUNITIES

MR. HODGE: I'd like to welcome you to the NASA/FAA Workshop on Wake Vortex Alleviation and Avoidance. My name is Ken Hodge, I'm from NASA Headquarters and I'm one of your Co-Chairmen. It's my great pleasure to introduce the other Co-Chairman of this meeting, Robert Wedan. Bob is Deputy Director of the Systems Research and Development Service of the Federal Aviation Administration.

MR. WEDAN: I would like to echo the the words of Ken Hodge and say that on behalf of the FAA I also would like to welcome you to this conference. Perhaps the first thing that's on your mind this morning, the minds of everybody as a matter of fact, is perhaps the weather. You might be wondering why we're not holding this workshop in Miami, but like most situations, there's a good side and a bad side. I won't mention the bad side, if you were driving in this morning you probably know that. The good side is that there's nothing to do outside so therefore it gives us the opportunity to really focus in on the questions that are before us at this conference. I say that not to be humorous but to be serious. I think that the subject of the Wake Vortex Alleviation or the Vortex Avoidance Systems is uppermost in the minds of those of us who have ahead of us decisions to be made on limited resources for R&D work. So, it is an important thing. We hope that you can put your minds to the task over the next two days to participate and get things rolling. I would like to introduce Jim Andersen, who is the Director of Air and Marine Systems here at TSC, who will be speaking as host, and be extending to you words from the Director.

MR. ANDERSEN: Thank you, Bob, and good morning.

Jim Costantino had to be away from the Center for a few hours this morning, and so he has asked me to welcome all of you to TSC and the FAA/NASA sponsored Workshop on Wake Vortex Alliviation and Avoidance.

We have been playing a major role in the FAA Wake Vortex Program, and as many of you know, TSC developed the Vortex

Advisory System which is scheduled to begin an operational test at Chicago's O'Hare International Airport in the spring.

As some of you may already know, TSC sponsored an International Conference on Aircraft Wake Vortices in March of 1977. That Conference brought together transportation and aeronautical specialists from government, industry, and academia from the United States and around the world to discuss the progress being made in analyzing wake vortices and the experimental systems and alleviation devices developed to cope with the vortex problem.

It is a particular pleasure to welcome back those of you who were here last year. I also want to extend a special welcome to those of you who are users of the airspace, as well as those of you who have come to help address the basic questions of operational philosophy and economics, which affect all of us and which must be resolved prior to reducing the delays and regaining the lost capacity of our nation's high density air terminals.

For those of you who do not know us yet, let me say a brief word about our respective roles collectively here at TSC in Cambridge. This Center is the Department of Transportation's major research, analysis, and development facility for highway, air, rail, pipeline, and marine modes of transportation.

With an annual budget of \$60,000,000 and a staff of approximately one thousand federal employees and support contractors, TSC carries out major R&D programs for the Office of the Secretary of Transportation and for all major agencies within the Department of Transportation, hence our direct support of the FAA Wake Vortex Program.

We also provide the Department of Transportation and state and local governments as well as private industry with engineering, economic, and planning information for all types of transportation programs. We are involved with problems of urban, intercity, rural, and national passenger and freight transport, and the analytical support to the entire Department with a professional staff.

We have engineers, scientists, community planners, economists, mathematicians, sociologists, and computer specialists. TSC is currently engaged in more than one hundred fifty research projects.

While you are here, you may wish to see what it is that we are doing, some of the work that we are doing; therefore, I want to take this opportunity to invite all of you to come and visit our Flight Service Station Automation Laboratory. The Flight Service Station Automation Laboratory utilizes a computer controlled voice response technique to encode current weather data, and in turn, it provides automated voice pilot preflight weather briefings via telephone.

This system is currently undergoing a very successful operational test in the Washington, DC area.

Another of our laboratories which may be of some interest to you is the Tire Testing Laboratory, which analyzed the DC-10 tires from the March 1, 1978, Los Angeles air crash for the National Transportation Safety Board.

The Dynamometer Laboratory and the computer facilities are a few of the other areas here at TSC which you may care to visit while you are here.

If you should like to make a tour of the laboratories, please leave your name at our Message Center.

All the necessary arrangements will be made for you to participate in a tour of the laboratories.

Once again, welcome; I hope your stay here is a pleasant one.

I would now like to turn the rostrum over to Dr. James Kramer, the Associate Administrator for Aeronautics and Space Technology in the National Aeronautics and Space Administration.

Dr. Kramer.

DR. KRAMER: Thank you, Jim, for the introduction and also for the hospitality here at TSC. We appreciate being able to turn over the details of taking care of a group of people like this to

a group as competent as TSC and who are generous in their support. We do appreciate it.

We have had several conferences on Wake Vortex Alleviation going back over the last several years. Jim mentioned the one that was up here a year ago, and previous to that we had a symposium in Washington discussing the topic, and we are going to do it again here today at this conference. I would like to make a special note of the fact that operating in this mode with the opportunity for a very free exchange of views during the course of the program is precisely the kind of activity that I encouraged the NASA people to be involved in so that we do indeed remain in touch with the aeronautical user community. The community, we hope, is looking forward to the results of the research and technology advancement efforts that are being made in the NASA laboratories and, under NASA funding, by industry, universities, and non-profit organizations. I am not at all an expert on wake vortices. I'm not an aerodynamicist. I was carried that way on the NASA rolls for a while, back a few years ago, when I was head of the Aerodynamics Division in NASA Headquarters and Al Gessow was working for me. He had just hit the motherlode of funding because the FAA had pronounced the wake vortex a very significant problem. As a result, Al had parlayed that statement into about a \$15 million check for doing research on wake vortex alleviation.

My view of the program is one of a very interested general manager with no detailed technical expertise in the area. So I feel perfectly qualified to tell you what my views are on the work on wake vortex alleviation.

We have invested -- I don't know the number precisely -- but something between \$10 and \$20 million of NASA resources in support of the national objective of finding ways of modifying aircraft or in general alleviating the wake vortices which are generated by transport aircraft. And I would say that the work that has been done by the people involved, whether working for NASA or working for industry as partners in the total team, has been

a very competent engineering job. My impression of the results that we will all hear a lot more about today is that very interesting and useful engineering information has been generated which could lead to significant alleviation of the wake vortices being generated by aircraft; however, this research activity did not lay the golden egg. No solutions to the wake vortex problem have been found which don't weigh anything, which don't generate any drag, which don't increase noise, or which don't cost something. I've been involved in advanced technology activities for some time and I've never found one of those. So I think it is perfectly unrealistic to expect that we're going to find one in this area either.

I'm somewhat concerned, therefore, and I find this a particularly timely spot in the program to assess just where we are going with this kind of activity. I see us having in place a good NASA/industry team which is quite competent to do first-class engineering work on a significant national problem, and it is really time to decide what we're going to do with that capability. I do not mean to say that the capability, just because it is good and has been generated by a NASA/industry team, has got to be used; on the other hand I do think that if this kind of information being generated by our first-class engineering teams does not have a reasonable prospect of being used, we should direct our efforts into more productive activities because, Lord knows, there are plenty of problems associated with aeronautics in the United States.

So I see it as timely, and I think that we really need to have an extensive dialogue with the potential user community so that we know what directions our future research efforts should take and at what level we should pursue them. It's not a cheap business that we're in; we can carry it out at various levels of funding or various levels of resource investment and that's basically the kind of decision we're faced with in a general management function like ours in NASA headquarters. It is up to you people to discuss the alternatives, to decide which ways of coping with

this air transportation system problem are the most appropriate and to define for us what indeed makes sense for NASA to be doing.

I hope you'll do that and take it seriously in the next couple of days and keep the lines of communication open to us. But I would also encourage you not to expect the golden egg, but to put before you good, honest, practical engineering work which has the potential of having a significant impact. However, it is only relevant if that significant impact is indeed needed by the air transportation system.

Thanks very much.

MR. BLAKE: Thank you, Jim.

Al Albrecht, Acting Associate Administrator for Engineering Development for FAA has asked me to pass on to you his regrets at not being able to be here personally today. He also wanted me to emphasize his feelings on the very high importance that he places on the subject of this conference. So in his behalf, I would like to join Jim Andersen and Jim Kramer in welcoming you to this conference.

Now, since they have already covered the overall purpose of the workshop, I would like to take the next several minutes to underscore the importance which FAA and the aviation community attach to the development of wake vortex detection, prediction and alleviation techniques. We believe that these techniques either alone or in combination with an automated terminal area traffic management function are the key to achieving the reduced interaircraft arrival spacings which in turn are the key to helping us achieve our goals of higher airport capacity.

Our later speakers will present an assessment of the importance of achieving reduced spacings, measured in terms of the financial and operational gains accrued to the users of the air space, particularly at our major airports. And as you will see, relief from the use of the present relatively large interaircraft spacings that we believe can be achieved through use of vortex

detection and alleviation systems offers what appears to be very, very substantial benefits indeed.

Now, many of you know that we initiated a broad ranging activity last spring, to focus our future engineering and development programs on the major problems as seen by the aviation community. Nearly 60 organizations with approximately 250 experts have been participating in this new engineering and development initiatives activity. And they've been working very intensively to examine the needs of aviation and to help FAA to establish the best new engineering and development program for the future. And they have focused very heavily on the problem of airport capacity which in their minds, and the minds of many, is the major continuing problem facing the aviation community.

Now we all know that the ideal solution would be more runways, more airports, including general aviation or commuter runways at our major hubs. But we all know the practical difficulty in achieving this solution and this is pointed up to us by the new engineering and development engineering initiatives experts. They are doing everything possible to increase the capacity at our existing airports. And although the final report and the recommendations of the new E&D initiatives activity in this area are still to be submitted to FAA, the group dealing with this effort has concluded that whatever could be done to reduce inter-arrival spacing, to reduce runway occupancy time, and to alleviate the effects of wake vortex turbulence must be done, and must be done very energetically.

We would like in these two days to share with you the efforts that we at NASA and the FAA have underway, and their respective results as we see them. And also to solicit from you advice and guidance to both FAA and NASA on the best ways to move ahead, and to produce the needed reductions in delay and increases of effective capacity at our major airports.

Many of you already know that NASA has been working on the alleviation of wake vortex effects at the source, while FAA has concentrated on systems to detect and to avoid the effects of

wake vortex turbulence through the use of ground based systems. And this latter effort has involved the staff here at TSC very heavily in the design of vortex detection and avoidance systems.

We believe that the work to date has shown the potential of this type of system, and we look forward to your advice and guidance in defining our future efforts and placing the proper development emphasis in this most important area. Before turning the rostrum over to Jerry Chavkin, I would like to thank the Transportation Systems Center for their very special efforts in supporting this conference; and our special thanks to Jim Andersen and Bill Wood, who have taken care of the physical arrangements for us here in Cambridge.

Jerry?

MR. CHAVKIN: Thank you, Neal, and good morning ladies and gentlemen.

You'll notice in your program that Jim Andersen and I, besides being participants, are also listed as organizers. One of the jobs of the organizer is to make some logistic announcements so I'm going to do this very quickly, and any questions you have we'll handle later.

There's a message center directly outside the door. There are two young ladies out there who have been involved in setting up the conference. There's a number that you can leave with us if you want your office to get a hold of you, even when you're in workshops. The message center will take care of things for you. If you haven't registered, we'd appreciate it if you'd register at the desk because you'll get a copy of the proceedings that way and of course, we would like all of you, even if you've registered, to make sure that you sign up for one of the workshops, if in fact you intend to be here tomorrow. That doesn't mean that you can't go from one workshop to the other, but we'd like to have those of you who are interested in a specific area, please sign up for a workshop and focus your efforts in that particular workshop.

Those of you who are speakers, please well before your time for speaking, get your visuals to the audio/visual desk, which is right outside the door. Because of the rearview projections, they have to get the material back there ahead of your presentations.

There is a blue sheet in your handout that gives you the bus schedule. There will be buses going back tonight at 6:00 and 7:45 to the Copley Plaza. There's a bus coming here from the Copley Plaza tomorrow morning and going back tomorrow night to the airport at 5:00 P.M. The schedule is in your handout.

Now, one other thing -- You'll notice breaks and lunches on the agenda. At all the breaks, if you wish coffee you can go right up to the cafeteria on the second floor and get it. The lunches are timed pretty close, an hour to an hour and 15 minutes. The cafeteria can easily handle all of us here and if you haven't had the pleasure of government cuisine in the last couple of years or couple of weeks or couple of days you're going to find some of the best government cuisine right here on the second floor. However, if you want to go outside and suffer in the rain and the snow and the sleet of Boston there are restaurants around here that you can deal with. Please try and be back on time.

There is a social hour tonight from 6:00 to 7:45 and it's going to be up in the cafeteria. We hope all of you will attend the social hour. There will be a bus going back downtown after the social hour as well as one before.

There will be space in the lobby here tomorrow for your luggage. If you bring it back on the bus and leave it here, it can be left right in the lobby where it will be secure. The powder rooms are right outside the door. One thing I would like to point out is that on the program you'll find today that we have a session devoted to remarks from the airplane manufacturers. If there are any of you who represent airplane manufacturers that are not on that particular program, but you have decided you'd like to say something, please let Ken Hodge know.

Also, and this pertains to tomorrow morning between 8:30 and 10:30 we have devoted time to listen to the aviation community, other than the airplane manufacturers, and what they have to say about wake vortex. And if any of you would like some time on tomorrow's session, between 8:30 and 10:30, I encourage you to see Bob Wedan, who will chair that session, and he will get you on there in the morning.

In the sessions that we're going to have today as long as we can stick to the schedule, we'll allow questions, but I think it's more important to stick to today's schedule and then have the questions brought out in the workshops tomorrow. So if there is time we'll allow questions in the session today otherwise we will move through the sessions essentially on the schedule.

Now, the session I'm chairing deals with what we call Opportunities Analysis of Wake Vortex Avoidance Systems. The question is one of potential. The question is one of delays in the system. The question is one of, as Neal Blake brought out, how are we going to build new runways. Are we going to build new major hubs or are we going to have to get the most capacity out of what we have today. The analysis to be presented by Dr. Agam Sinha of the Mitre Corporation is preliminary in that it hasn't been completely documented yet. But the basic analysis is in fact complete. We have taken a look at the projections for the next 15 years for the major hub airports and looked at what it would take to get capacity increases at those airports through the use of reduced longitudinal spacing. Now let me point out that some of you might have been at the new initiatives conference last spring when we got the message to the group that the major issue in capacity was reducing longitudinal separation in the system in order to gain back the capacity we've lost through wake vortex separation and to further gain increases in capacity on the runways that exist at the 22 major hub airports.

Now, before Agam starts, I want to point out one thing to you. There is always a problem when you present a global study, and that's what Agam is going to present to you. But I want to

make sure that you understand that we have airport improvement working groups going on right now at 10 major hub airports. We are doing delay analysis on each specific airport, involving the operators, the airlines and the FAA people at the airport. At places like Chicago and Denver, this will mean making specific runs on their forecasts with the traffic and conditions they see for 1985 to 1990. The results are coming out very close to what Dr. Sinha is going to show you.

So this is not something that we dreamed up. Traffic will increase. The capacity of our major hub airports is one of the most significant problems in the aviation system today. It appears as though the only game in town is longitudinal separation decreases. What's it worth? Dr. Sinha.

DR. SINHA: Thank you, Jerry, and a good morning to everybody.

I'd like to start off with the first vu-graph. What I'm going to be talking about today is the analysis of potential advanced vortex systems separation standards. To give you a little bit of a background of what we are talking about here, several studies have indicated, that the vortex systems have to provide the key to reducing separation standards.

What I mean by advanced vortex systems can be either vortex alleviation at the source or monitoring and prediction of vortices by the ground based system. The objective of the analysis that I'm going to be talking about today is to assess and quantify the delay reduction benefits that might be experienced with reduced separation standards. The analysis will be presented in three parts. The first will be a comparison of the vortex advisory system versus today's standards. By vortex advisory system I mean the system that has been developed by TSC and is currently in position at Chicago O'Hare and expected to undergo operational tests very soon.

The next step logically, as we see it, is a 2.5 nautical-mile minimum standard that takes us beyond the VAS 3 nautical-mile minimums; and finally, if we are successful in all our efforts we would hope to reach 2 nautical-mile minimums.

Opportunities Analysis of Potential Advanced Vortex Systems Separation Standards

1-14

Background

- **Advanced Vortex Systems**
 - **Key to Reducing Separations**
 - **Source or Ground Based**

- **Objective of Analysis**
 - **Assess/Quantify Delay Reduction Benefits**

- **Three Parts**
 - **VAS vs. Today**
 - **2.5 NMI Standards vs. VAS**
 - **2.0 NMI vs. 2.5 NMI Standards**

To give you a very brief overview of the methodology that we use, we started with a parametric set of separation standards for any given scenario. When we combine that with the airport operating conditions, in terms of runway configurations, aircraft mix, and other related specific variables, we can estimate the capacities for the 1985 and 1995 time frame, which we have chosen for this analysis. All our analysis deals with the top 20 air carrier airports. On the other side of the coin, we need to get a handle on the demand projections. Our starting point was the FAA annual demand projections which we converted into 24 hour daily demand profiles based on today's profiles that we see at the specific airports which in some form is a representation of the desire of the public to fly. A combination of the matching of the capacities and the demands then allows us to get at the annual delay estimates through some analytical delay models. For this analysis we have stayed away from simulation, which is being conducted at specific airports, as Jerry mentioned.

To get a dollar benefit out of the annual delay estimates, you have to deal with aircraft operating costs, and I'll talk in some detail later about that topic. Once we have the annual delay costs for each system, then we can discount it back for the period 1985 to 1995. We have used an OMB guideline of 10 percent discount rate to get at the total delay picture. The delay savings benefit, which I'll be talking about in the results of this analysis, is then nothing but the difference between the total delay costs for the two candidate systems that we are comparing.

Let me take a moment to talk about the IFR separation standards that we will be using. Let's concentrate on that number for a minute. To orient you to what you see on the board, the No. 6 represents, under today's set of rules when the lead aircraft is a heavy (300,000 pounds or more) and the trail aircraft is small (less than 12,500 pounds), then the applicable standard is 6 nautical miles. What we expect to see under an operating vortex advisory system is almost all separations being 3 nautical miles.

Methodology

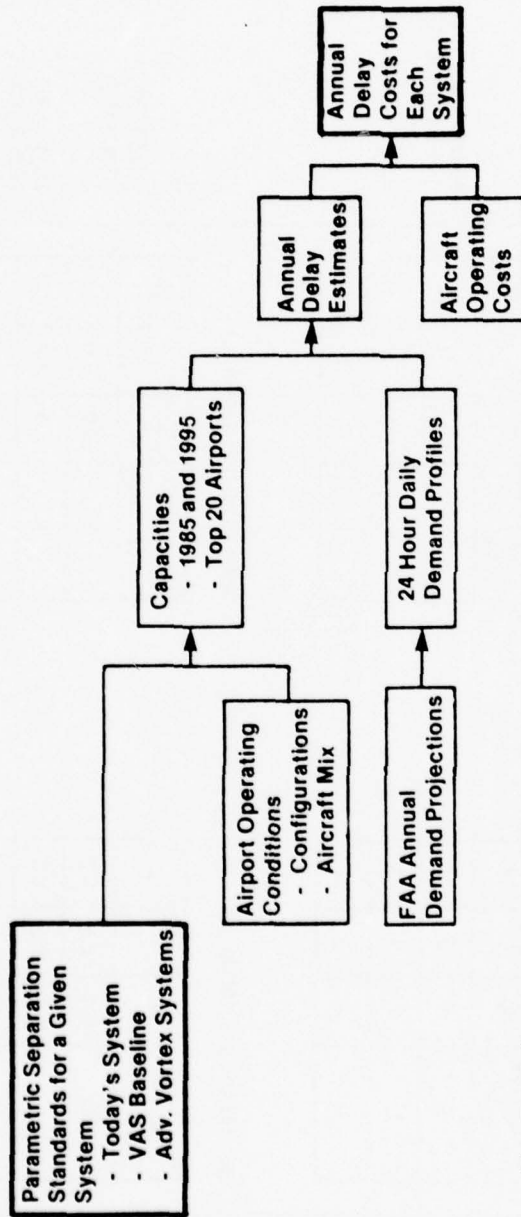

- For Each System, Annual Delay Costs for the Years 1985-1995 Are Discounted Back to 1985 to Give Total Delay Costs
- Delay Savings Benefit Is Then Calculated as the Difference of the Total Delay Costs of the Candidate Systems

IFR Separation Standards

Arrival/Arrival (NMI)		Dep/Dep (SECS)																																																
<p>Set 1 (Today's)</p> <table border="1"> <tr> <td></td> <td>S</td> <td>L</td> <td>H</td> </tr> <tr> <td>Trail</td> <td></td> <td></td> <td></td> </tr> <tr> <td>Lead</td> <td></td> <td></td> <td></td> </tr> <tr> <td>S</td> <td>3</td> <td>3</td> <td>3</td> </tr> <tr> <td>L</td> <td>4</td> <td>3</td> <td>3</td> </tr> <tr> <td>H</td> <td>6</td> <td>5</td> <td>4</td> </tr> </table>		S	L	H	Trail				Lead				S	3	3	3	L	4	3	3	H	6	5	4	<p>Set 2 (VAS)</p> <table border="1"> <tr> <td></td> <td>S</td> <td>L</td> <td>H</td> </tr> <tr> <td>Trail</td> <td></td> <td></td> <td></td> </tr> <tr> <td>Lead</td> <td></td> <td></td> <td></td> </tr> <tr> <td>S</td> <td>3</td> <td>3</td> <td>3</td> </tr> <tr> <td>L</td> <td>3</td> <td>3</td> <td>3</td> </tr> <tr> <td>H</td> <td>4</td> <td>3</td> <td>3</td> </tr> </table>		S	L	H	Trail				Lead				S	3	3	3	L	3	3	3	H	4	3	3	<p>60/90/120 (For Sets 1 & 2)</p>
	S	L	H																																															
Trail																																																		
Lead																																																		
S	3	3	3																																															
L	4	3	3																																															
H	6	5	4																																															
	S	L	H																																															
Trail																																																		
Lead																																																		
S	3	3	3																																															
L	3	3	3																																															
H	4	3	3																																															
<p>Set 3 (AVS: 2.5 NMI Min.)</p> <table border="1"> <tr> <td></td> <td>S</td> <td>L</td> <td>H</td> </tr> <tr> <td>Trail</td> <td></td> <td></td> <td></td> </tr> <tr> <td>Lead</td> <td></td> <td></td> <td></td> </tr> <tr> <td>S</td> <td>2.5</td> <td>2.5</td> <td>2.5</td> </tr> <tr> <td>L</td> <td>3.0</td> <td>2.5</td> <td>2.5</td> </tr> <tr> <td>H</td> <td>3.5</td> <td>3.0</td> <td>2.5</td> </tr> </table>		S	L	H	Trail				Lead				S	2.5	2.5	2.5	L	3.0	2.5	2.5	H	3.5	3.0	2.5	<p>Set 4 (AVS: 2.0 NMI Min.)</p> <table border="1"> <tr> <td></td> <td>S</td> <td>L</td> <td>H</td> </tr> <tr> <td>Trail</td> <td></td> <td></td> <td></td> </tr> <tr> <td>Lead</td> <td></td> <td></td> <td></td> </tr> <tr> <td>S</td> <td>2.0</td> <td>2.0</td> <td>2.0</td> </tr> <tr> <td>L</td> <td>2.5</td> <td>2.0</td> <td>2.0</td> </tr> <tr> <td>H</td> <td>3.0</td> <td>2.5</td> <td>2.0</td> </tr> </table>		S	L	H	Trail				Lead				S	2.0	2.0	2.0	L	2.5	2.0	2.0	H	3.0	2.5	2.0	<p>60/60/90 (For Set 3)</p> <p>60/60/60 (For Set 4)</p>
	S	L	H																																															
Trail																																																		
Lead																																																		
S	2.5	2.5	2.5																																															
L	3.0	2.5	2.5																																															
H	3.5	3.0	2.5																																															
	S	L	H																																															
Trail																																																		
Lead																																																		
S	2.0	2.0	2.0																																															
L	2.5	2.0	2.0																																															
H	3.0	2.5	2.0																																															

which gets us back to where we were a few years ago. The standards that you see for advanced vortex systems, 2.5 nautical-mile and 2 nautical-mile minimums are compatible with all the specific task forces that are going on right now. You will notice under the 2.5 nautical-mile minimum, for example, that most of the standards are 2.5 miles; however, to be conservative where vortices might be a greater hazard than others, we have picked some standards that are larger than 2.5 nautical miles, namely 3 and 3.5. A similar scenario is presented in the 2 nautical-mile minimum standards.

On the right side of the screen, we have assumed a certain reduction in the departure/departure spacings in seconds, which are again consistent with the task force studies. Now, one of the questions which I'll leave you with at the end of the analysis is, Are those real numbers? What do we have to do to get to these departure separations?

To briefly go over the rest of this study assumption, we are interested only in the IFR average delay per operations. We have not assumed any benefits for advanced vortex systems under VFR operations. For the sake of simplicity we have assumed a linear interpolation between 1985 and 1995. In the kinds of delays that we are talking about, this does not present any significant deviation from actual values. In terms of aircraft operating costs, there have been a number of discussions whether to include rentals, depreciation, passenger costs, and so forth. Again, to be on the conservative side, we have assumed only the direct incremental operating cost of the aircraft, namely the flying and maintenance costs. It does include the flight crew as well as the cabin crew. All the values that you see will be expressed in 1976 dollars, the prime reason for that being that the latest aircraft operating data available was for that year. However if you want to translate it into any other year, it's just a question of simple multiplication by the inflation factors.

Study Assumptions

- **Compute 1985 and 1995 IFR Average Delay per Operation**
- **Assume Linear Interpolation Between 1985 and 1995**
- **Use Aircraft Flying and Maintenance Costs Only**
- **Express All Values in 1976 Dollars**
- **Analyze IFR Separations and IMC Weather Only**

As I mentioned earlier, I will be addressing only instrument meteorological conditions and we claim no benefits for VFR operations. Before we get into the results, let me take a moment here to discuss the relationship of demand and delay. Let's concentrate on the first curve which talks about today's system. As you can see, when the demand grows on the X axis, the average delay in terms of minutes per operation has a very distinct knee in the curve. What that means is that when you come close to saturation there's a very rapid increase in the delays experienced by the aircraft. Now I don't know whether that number should be 14 or 16 or 18, but for example, suppose we assume that 15 minutes per operation is the order of the delay that is going to be experienced by the projected demand under today's system. If that number is too high then what will actually happen is as follows -- Let's for a moment look at this line. This represents some level of acceptable delay that the public is willing to live with. For example, 4 minutes per operation. Now, I'm talking about every aircraft at the top 20 airports. What we would then expect to happen under today's scenario, as the demand reaches a point where the average delay is 4 minutes per operation, is that the growth of aviation will be stifled. The economics of the situation would not allow it to grow. However, if we manage to get to the VAS separation standards, the delays will drop and subsequently there will be some growth in aviation until we come back to an acceptable level of delay. This process will then repeat itself if we manage to keep on increasing the capacities of the airports.

What we are doing by comparing the delays at the projected demand levels is trading off this additional demand that has to be turned away because of the lack of capacity versus the additional delay savings that is some representation of the value of the demand that was turned away.

To give you some idea of the numbers, the value of the delay that we've associated with this demand that is going to be turned away, represents about \$50 per passenger. So we feel that this is not unrealistic, in fact, it is on the conservative side.

Relationship of Demand and Delay

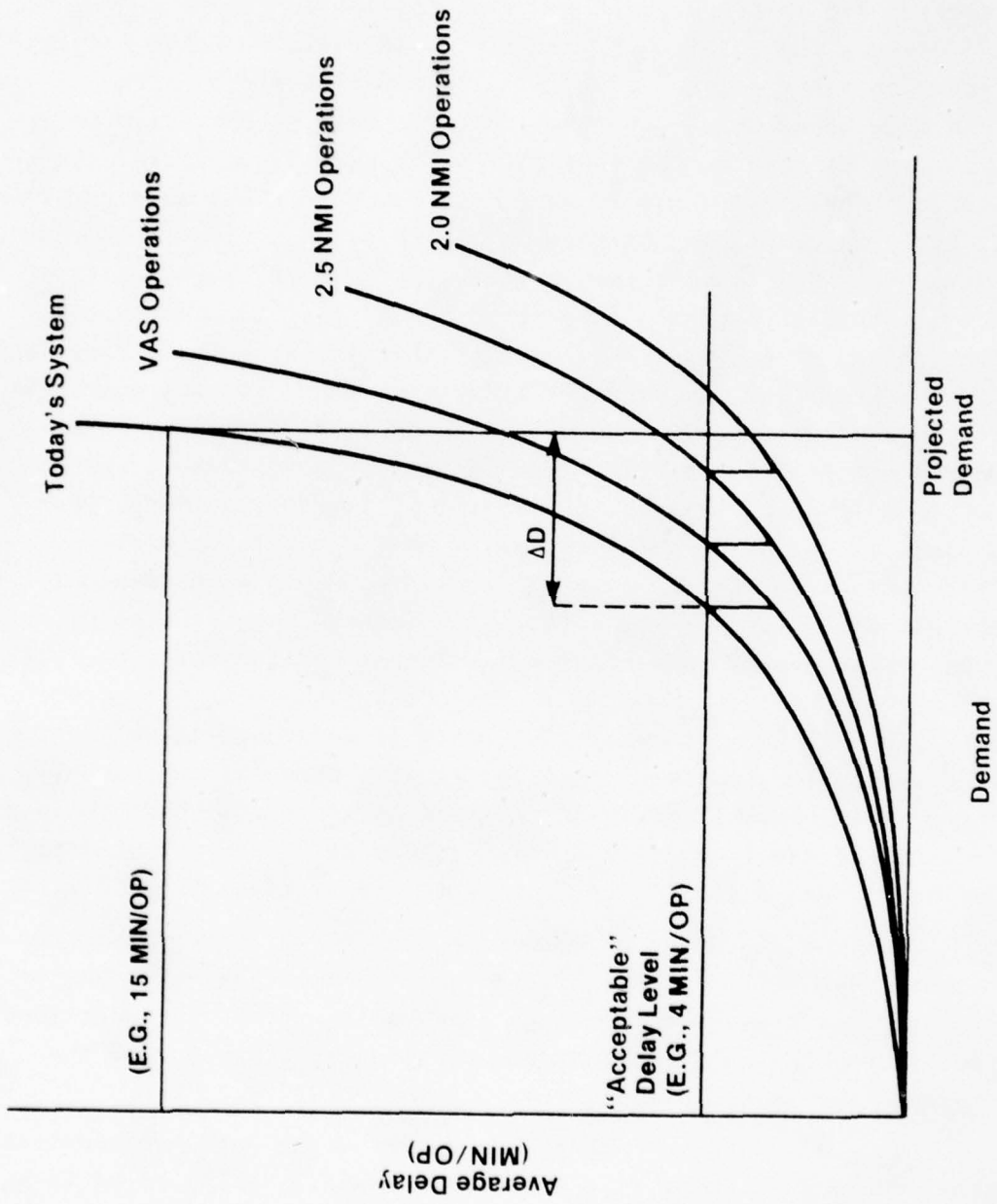

What are the results that we get out of this analysis? We'll be looking at the maximum potential annual delay savings to give you a rough idea of annual numbers. Then we'll also present to you the total delay savings for our time period which is 1985 to 1995 for varying percent effectiveness for the three scenarios that I mentioned earlier. What this is supposed to indicate then is a first-order magnitude of what the potentials of vortex systems would look like.

What we have here is a plot of the calendar year versus the annual delay savings in 1976 dollars for the top 20 airports. The bottom line represents a VAS base line representing 40 percent operations under the VAS standards that you saw earlier and 60 percent fallback operations under today's standards. These numbers have come out of a detailed TSC analysis of the winds at the various airports and represent a fairly good, average percent of operations over the top 20 airports. What this says then is that over today's standards we can expect to save something of the order of \$150 to \$200 million a year, if we could get the VAS base line to work.

One way of getting further reductions in delays is to increase that 40 percent number. Can we get the VAS to operate at a higher percentage? The top line that you see over here shows what would be the delay savings if we could get up to 100 percent VAS effectiveness, that is 3 nautical miles all the time; however, we know realistically that that is not going to be so. So in reality, if we increase the VAS base line and achieve a higher percentage of time that we can operate under 3 nautical miles, we are talking about somewhere in the range of \$250 to \$300 million savings a year at the top 20 airports.

You can see the other two graphs up there on a similar plot for 100 percent effectiveness effectiveness of 2.5 and 2 nautical miles. Again, the message that I intend to bring out on this chart is not that these are the realistic numbers that you'll ever be able to achieve, but that the potential of going beyond

Application of Estimated AVS Benefits

- Breakeven Estimate of F&E Outlay
- Assumptions
 - Recover Costs within the 1985-1995 Period
 - F&E Occurs in 1985
 - O&M per Year = 10% of F&E
 - R&D Costs Not Included
 - Discount Rate of 10%
- Output
 - First Order Estimate of F&E Such That
F&E + O&M Costs = Delay Savings Benefit

Maximum Potential Annual Delay Savings at Top 20 Airports

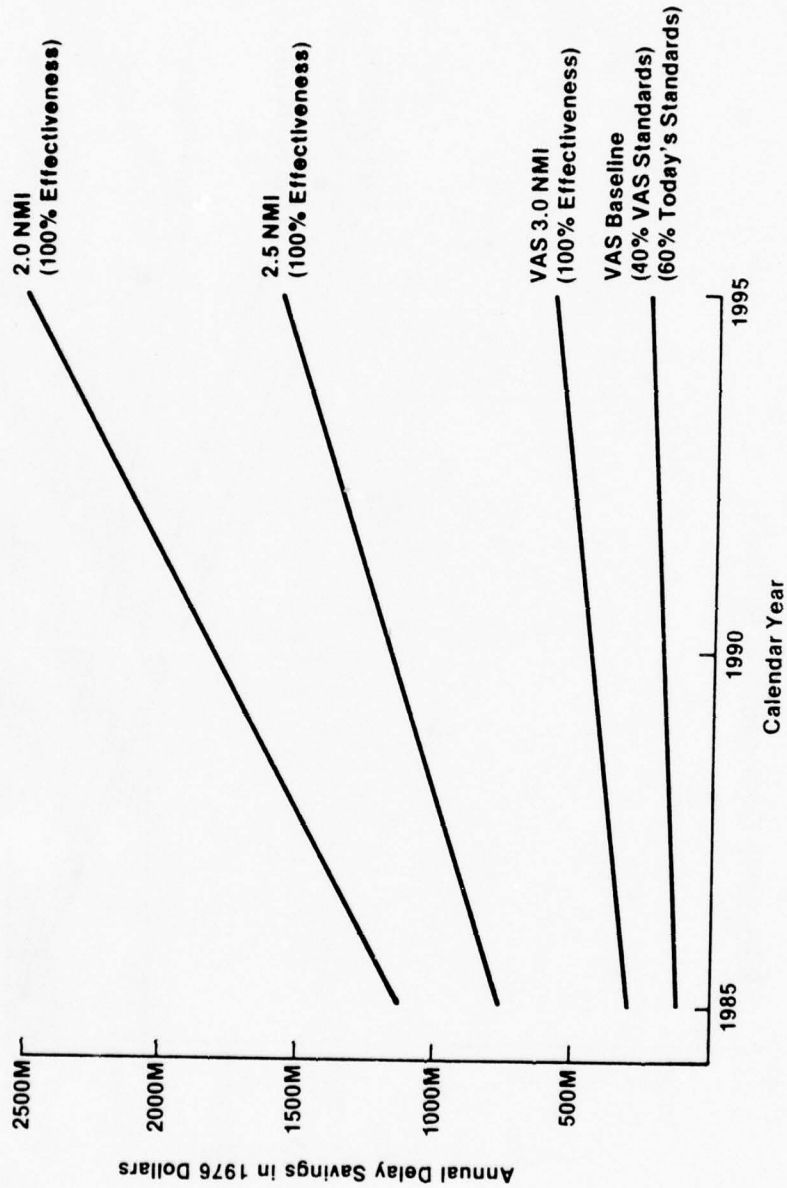

IFR Delay Savings of VAS Standards vs. Today's Standards (1985-1995 Discounted to 1985)

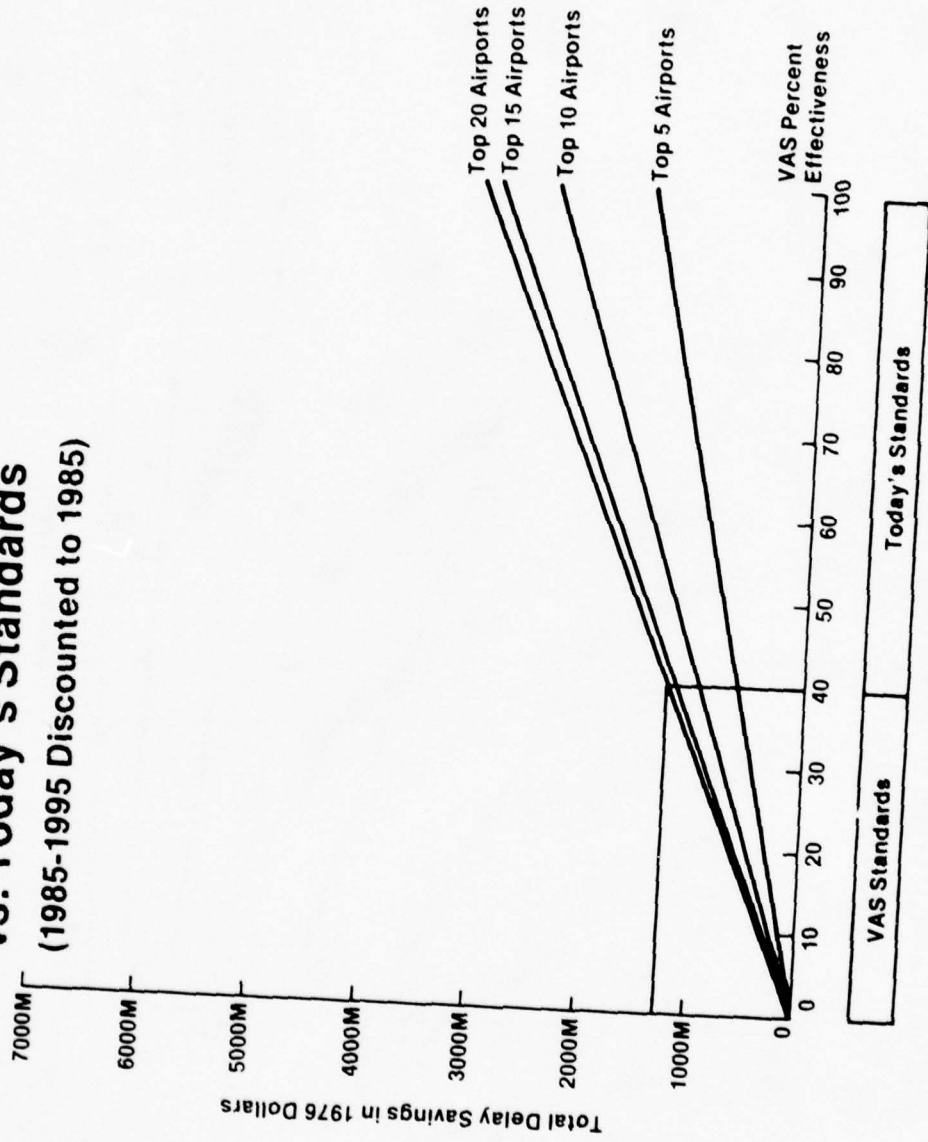

IFR Delay Savings of 2.5 NMI Standards vs. VAS Baseline Standards (1985-1995 Discounted to 1985)

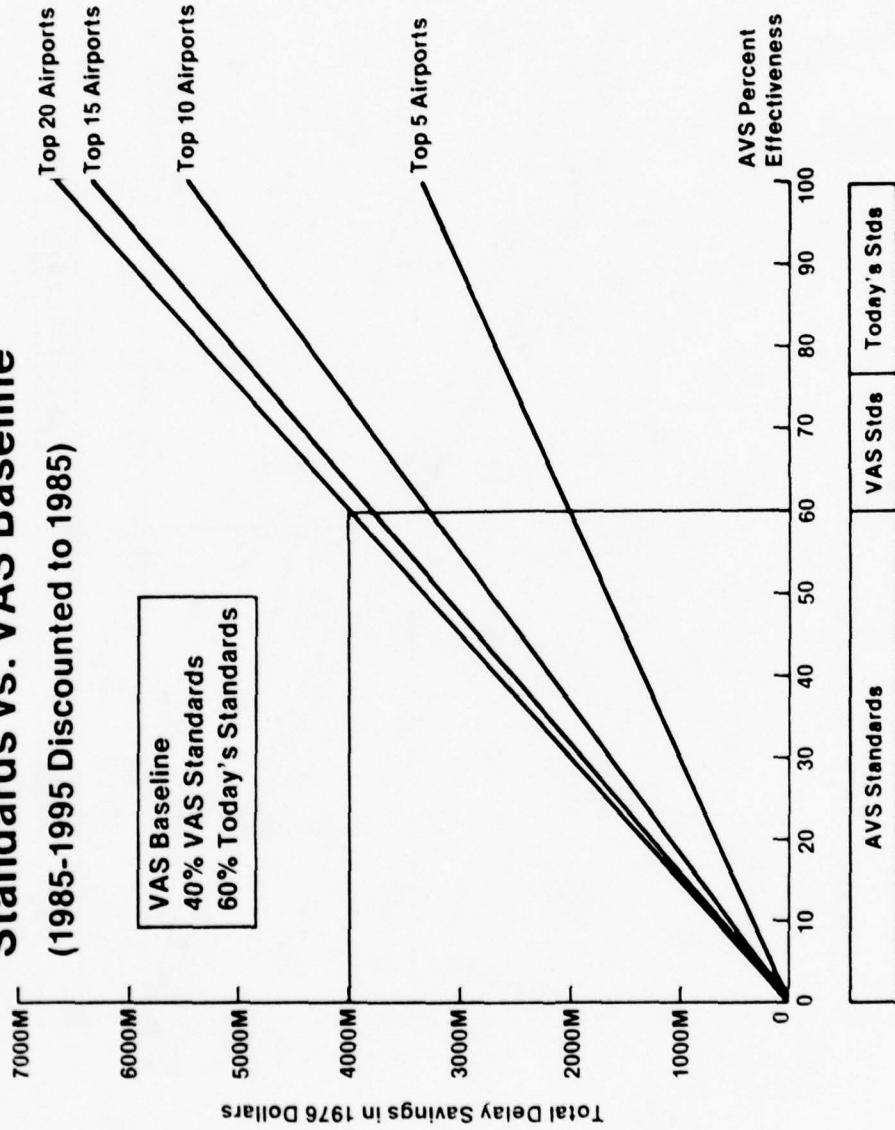

IFR Delay Savings of 2.0 NMI vs. 2.5 NMI Minimum Standards

(1985-1995 Discounted to 1985)

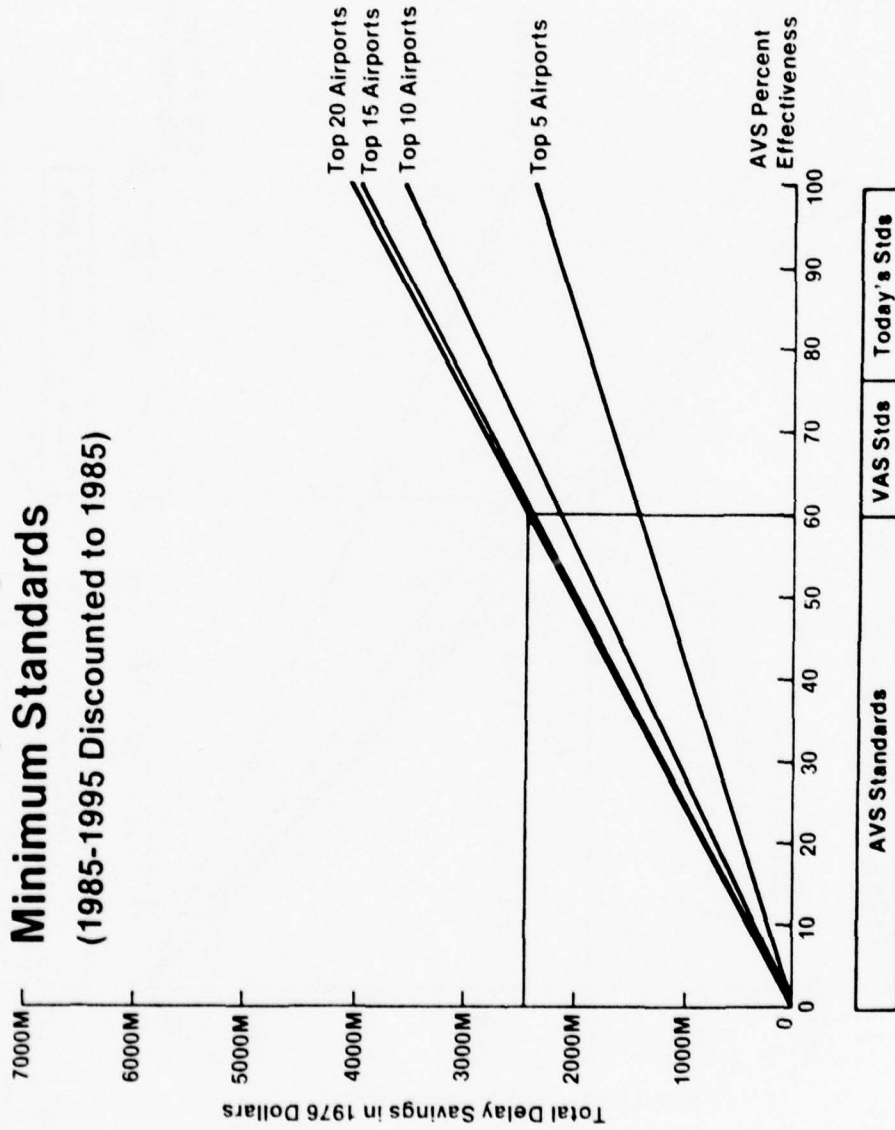

3 nautical miles is very large. So even if you get a 50 percent, 2.5 nautical-mile standard, you are still talking about over \$500 million savings a year.

Let us look at the IFR delay savings of VAS standards versus today in terms of a VAS percent effectiveness versus total delay, which is nothing but the integration of the previous curve that you saw over the timeframe, discounted at 10 percent. The total delay then for the 11-year period at 100 percent VAS effectiveness is of the order of \$3 billion for the top 20 airports. Again, that not being a realistic number, if you look at the 40 percent VAS (in which we operate the 3 nautical miles standard 40 percent of the time and today's standard 60 percent of the time), the savings are still very, very large; more than \$1 billion over the 10-year period.

This is a similar graph for 2.5 nautical miles standards versus the VAS base line comparisons. To reiterate, the VAS base line is 40 percent VAS standards and 60 percent today's. Now, here you see the numbers are getting astronomical. At 100 percent effectiveness for 20 airports you are talking about \$6 billion in 11 years. Granted, this includes the costs of the passengers that we do accommodate under 2.5 nautical miles, but we do now under today's VAS standards. So there are some economic factors involved in this. However, even if you claim that the full projected demand is not going to be met, the numbers are still going to be very large. If you look at the realistic figure of 60 percent operations under the 2.5 nautical-mile scenario for the top 20 airports, you're really talking about \$4 billion worth of either passenger delays or allowing passengers to fly who would not under normal scenarios.

The other thing that I would like to point out on this curve is the difference between the top 20 and the top 15 airports. That is a representation of the degree of saturation at the various airports under the projected demands. It also gives us a clue that we are not really talking about 2.5 nautical miles and 2 nautical miles on the system-wide basis. It has to be geared toward a specific airport.

The final part of the analysis deals with the comparison of 2 nautical miles versus 2.5 nautical miles in a similar scenario. Here, what we are talking about is for a given percentage effectiveness of advanced vortex systems, if we could go down to 2 nautical miles instead of 2.5 nautical miles, what would the delay savings look like at the top 20 airports? An absolute maximum potential, which we know we cannot attain is of the order of \$4 billion, and to take it back to the same comparison of 60 percent advanced vortex system operations, we are talking about \$2.25 billion to \$2.5 billion at the top 20 airports for 11 years.

These are all incremental benefits and they add up to a lot of dollars. How does one go about using this analysis? Is it any use to talk about these kinds of numbers? We have tried to apply it to a case of estimating what kind of F&E money can we spend either for ground systems or for vortex alleviation system, and still come out even over the analysis period. We have assumed that we have to recover the cost by 1995 and that all the F&E occurs in 1985, which though not realistic is a conservative way of approaching the analysis. Since we don't know what the systems are going to look like or what its operating and maintenance cost will be we have assumed 10 percent of F&E as the annual O&M costs. And again, in the numbers that you are about to see, we have not included any R&D costs because we don't know its order of magnitude right now. We have continued with the 10 percent discount rate that was used in the previous part of the analysis. The output of this sort of an approach then gives you a first-order estimate of equipment F&E such that you break even over the analysis period.

To give you a specific example for 60 percent effectiveness of 2.5 nautical miles VAS, for the top 20 airports: If you go through the mechanics that were outlined in the previous chart, you'll end up with \$2.3 billion available for F&E costs of reduced spacing equipment. And the reason why I stress the words reduced spacing equipment is that advanced vortex systems may not be the only thing that allows you to go down to 2.5 nautical miles.

Results

- **Maximum Potential Annual Delay Savings**
- **Total Delay Savings (1985-1995) for Varying Percent Effectiveness for**
 - **VAS vs Today's Operations**
 - **2.5 NMI Minimum Standards vs VAS Baseline**
 - **2.0 NMI vs 2.5 NMI Minimum Standards**

Application of Estimated AVS Benefits (Concluded)

- At 60% Effectiveness of 2.5 NMI Advanced Vortex System for Top 20 Airports
 - \$232OM Is Available for F&E Costs of Reduced Spacing Equipment
 - Assume Half of F&E Costs Needed for Non-AVS Equipment
 - Implies \$116OM F&E Costs for Advanced Vortex Systems

- For Ground-Based System,
 - Assume One AVS for Each ILS Runway
 - Requires 80 AVS Units for Top 20 Airports
 - Implies \$14.5M F&E Costs per AVS Unit at Breakeven Point

- For Airborne Vortex Alleviation Systems
 - Assume 3000 Jet Aircraft in the Fleet
 - Implies Approximately \$0.4M F&E per Aircraft at Breakeven Point

Again, not knowing the future, we have assumed half of the F&E costs for non-advanced vortex systems equipment like metering and spacing and other automation aids, or whatever else might be necessary to get down to the reduced standards. What that implies then is about \$1.2 billion available for advanced vortex systems. We have presented two examples here. For the ground based systems, let's assume that we need one AVS unit for each ILS runway at the top 20 airports. This requires approximately 80 units for the top 20 airports, which implies that we can spend up to \$14-1/2 million for each AVS unit and still come out even over the 11-year period.

Now, admittedly, when you include R&D costs in there, the 14.5 million would be reduced. However, the message that I want to leave you with is not the number 14.5, but that it is a large number and there should be a concentrated effort to get to an advanced vortex system. If you apply similar logic to the airborne vortex alleviation systems while keeping the top part of the example constant and assuming that we still spend half of the money for non-AVS equipment, and have \$1.2 billion for vortex alleviation systems, and if you look at the projections of the fleet, (even though we know that not necessarily all jet aircraft would need vortex alleviation systems), and we conservatively assume that 3,000 jet aircraft need AVS; what that tells us then is you get \$0.4 million F&E available per aircraft.

If we do not need any non-AVS equipment under the vortex alleviation system, that \$0.4 million per aircraft immediately becomes \$0.8 million per aircraft. And again, I would like to stress not the 14-1/2 or the 0.8, but that they are large numbers.

To summarize what we have seen here today, expected delay savings for 1985 to 1995 at the top 20 airports, under full projected demands, is \$1.25 billion for VAS versus today and an additional 4 billion at 60 percent effectiveness of 2.5 nautical miles advanced vortex system, and somewhat less moderate \$2.5 million if we can manage to get down to 2 nautical miles versus the 2.5 nautical miles.

Summary

- 1985-1995 Expected Delay Savings at Top 20 Airports Under Full Projected Demand
 - \$1.25B for VAS vs Today
 - Additional \$4.0B for 2.5 NMI AVS (60% Effectiveness) vs VAS Baseline
 - Additional \$2.5B for 2.0 NMI vs 2.5 NMI AVS at 60% Effectiveness

- Additional Questions in Specific Areas
 - Economic:
 - Costs of Alternative AVS Designs
 - Cost Effective Installation Criteria for AVS
 - Technical:
 - Upper, Practical Limit on AVS Effectiveness
 - For Ground-Based Systems
 - A. Same System for Arrivals and Departures
 - B. Lateral and Longitudinal Coverage Requirements
 - Operational:
 - Procedure and Time Requirements of Transitioning Between Standards

This only addresses one small aspect of the question and shows that there is a large potential. There is large benefit to be gained out there by reducing our separation standards. There are a number of other questions that certainly need to be answered before we can even hope to take any significant steps towards achieving that benefit. From the economic side, we have talked about the benefits of these systems. We have not talked about the costs. Is half a million dollars per aircraft a reasonable number? Is \$14 million per ground system a reasonable number or is it going to be much higher or much lower than that?

Also in this analysis we have not addressed the cost effective installation criteria for each system. We have assumed that it will be installed at all places -- at all 20 airports and on all jet fleet aircraft.

On the technical side, what is the upper practical limit of advanced vortex system effectiveness? If it can only hope to go to 2.5 or 2 nautical miles 10 percent of the time then the picture changes as opposed to the 60 percent that is used in the example here. For the ground based system, can we use the same system for arrivals and departures or do we need a completely different system for tracking departure vortices? What are the kinds of coverage that we would need in terms of lateral and longitudinal coverage on the approach path? And by that I mean should the coverage of the advanced vortex systems on the ground extend to the outer marker, middle marker, beyond the outer marker, 2,000 feet on the side to cover traffic merges and so on? We don't have answers to those yet.

From the operational side, even if the advanced vortex system does tell the controller that, yes you can go to 2.5 or 2 nautical miles, what are the operational requirements in terms of procedures? How long a lead time does the controller need to effectively transition from the terminal area standards to 2.5 and 2 nautical miles standards? By the same token, all of a sudden the advanced vortex system tells him, go back to 3 or 5 nautical mile standards;

how long does it take? Does it mean five missed approaches that have to be executed simultaneously or is a 10-minute warning time enough?

The net message that I want to leave you with is although the benefits as indicated by the analysis are substantial, there are a lot of hard questions that need to be answered and that is the purpose of this workshop. I hope we can come out with some very positive steps in that direction by the end of this workshop. Thank you very much.

MR. CHAVKIN: Well, I guess the first question you could ask is, Chavkin, have you lost your marbles completely? \$7 billion, \$5 billion, \$4 billion of delay savings. And we're talking about R&D programs in the millions. Why aren't we charging ahead? Well, I don't think I've lost my marbles but I think I'd like to put this in a little different perspective for you. In the first place, you have to understand that 5 of these 20 airports are reaching the knee of that curve today. Just ask the airlines if the system is becoming saturated. The alternatives to meet that saturation problem are not numbered in the 10's of 100's. There are a few alternatives, that reduce longitudinal spacing, and start bringing you back off the knee of that curve. And furthermore, I can be 90 percent off my marbles, not 100 percent, but 90 percent, and we're still talking about delay savings based on FAA and industry forecasts of traffic between 1985 and 1995 of \$400 million or 300 million. So we're talking about very big numbers in delay savings.

Now, I mentioned the delay task forces and want to point out two of them that are complete now. One in Chicago and one in Denver. These two task forces came up with numbers that are not suprisingly different than some of the numbers you see here. The Chicago task force said that if you could bring the Chicago system from 3 to between 2.5 and 2 miles in 1986, between \$25 and \$50 million per year could be saved at that one airport. The delay task force at Denver which we just completed said that in the year 1990 we could save anywhere from -- I think Denver was

30 to \$40 million in the year 1990, based on their traffic forecasts and the runways that exist today at Denver; 25, 30, 40 times 20 airports and you're up to \$1 billion a year. Now those results came from delay simulation runs on the specific airport, and are agreed to by the group that is involved in the airport improvement task forces. So the message is very simple. Don't believe \$4 billion. On a scale of 1 to 10 believe 1, \$400 million. There is so much capital, or dollars, or resources, to be saved by planning now for decreasing the delays that are going to occur at the top 20 hubs between 1985 and 1995, that we must investigate the best way to achieve this potential in the National Aviation System. That's the message we want to leave you with. And there's plenty of detail that we have to discuss with you in your workshops.

Now, we have -- If my watch is right -- five minutes to the break and both Dr. Sinha and I would be glad to answer any questions that anyone in the audience might have.

Yes, sir.

MR. AARDOOM: My name is Wim Aardoom, Air Traffic Service, Netherlands.

I have a question which I was going to ask anyway, one of these two days, that maybe is suitable now. Of course, when you're talking about investments for reducing separation below 3 nautical miles, it's at least my administration's opinion that you need a little bit more and you're thinking about improved radar systems. You're even thinking about automatic metering and spacing systems. My question is, what is the FAA view on this? Is it prerequisite for going below 3 nautical miles? Thank you.

MR. CHAVKIN: That's a very good question, and as a matter of fact, that's one of the hard questions that we're looking at as Neal Blake mentioned in the New Initiatives effort. And although Agam mentioned it, let me reemphasize the answer to that question. We are not saying that we can take our National Aviation System to 2.5 or 2 nautical miles separation standards by simply solving

the wake vortex problem. We've got to solve it. We've got to have a good percentage of time when we can operate at those standards. But we have said that we are looking at each of the other individual steps that it would take to bring the system to 2.5 and then down to 2 nautical miles. You're 100 percent right. We must look at metering and spacing, which by the way, our analysis shows has a great impact on reduced occupancy time on runways. We must also look at better surveillance and guidance in the system.

For instance, MLS, if you're going to talk about closely spaced parallel runways. We have to talk about tying in something like a wake vortex avoidance system incorporating an active sensor and a metering and spacing system, if we talk about 2.5 or 2 miles. If you have an alleviation system onboard an airplane, and you don't have a ground system, you're asking pilots to fly 2.5 or 2 nautical-mile separations IFR. We are very closely looking at the CDTI, the cockpit display of traffic information. And it all goes back to a premise that I guess I didn't state. The question is, can we take the system and operate it IFR basically as we operate it VFR today, with reduced spacings below three miles and do it day in and day out under IFR conditions? So you're right, sir, all of these other things must be considered. But it's a chicken and egg thing. We all agree we can throw up our hands and say we have to do all of them at once or we can attack a problem that's in the forefront and that's wake vortex. We'd like to get the system back to 3 nautical miles. We don't have to do anything technically to the system to take it back to the original standards of the mid-60's, 3 miles, except operate without the hazard of wake vortices in any given terminal area.

Yes, sir?

MR. ZALAY: I'm Andy Zalay from Lockheed. I agree with the points that you've made, but one of the questions I'd like to raise is the delay savings. One of the problems that industry has is calculating what a demand curve is for any type of a product, whether it's airline service or selling a commodity, and I'd like to point out that that's a very difficult number to get for the

airlines; and I'd like to give you an example. Yesterday I came in from Chicago and there was a five-hour delay and everybody stayed on the plane. Now, you have a 15-minute delay there and you assume that if people are going to have to wait more than 15 minutes they won't fly. That's not the case if the people are going long distance. On the other hand, I had to land in New York and they cancelled all the flights so I took a train. And there was a case where on a short distance the delay function is also a function of your route, and the point I'd like to make is that the delay is based on your demand curve and the demand curve is a very difficult quantity to tie down. As a matter of fact, I haven't seen it tied down for aircraft. I haven't even seen it tied down for things like Ivory soap. For the airliner the need is the elasticity of demand with price or the elasticity of demand with waiting time. I'd like to say that unless you can tie the demand function down, explicitly, the whole analysis that you're coming up with is somewhat impressionable on the airline industry. As a matter of fact, if you can in fact save a billion dollars and show that you could get a discount rate of 12 percent, people in the airlines would be investing it. So I'd like to say again you need to get that demand curve if you're going to make projections of the future of the cost benefits.

MR. CHAVKIN: Thank you. I think one point I would like to make is we wait anxiously for the airlines to comment on this. We have representatives of the airlines and ATA here, and the airlines know delays cost them money. It's no secret. And the President of ATA recently said frankly it was \$400 or \$500 million a year that delays are costing the airlines. The question of who does what to whom is a separate question from the fact that it does cost money. But there's one other point I would like to make. When we talk about a 15-minute average delay, peak hour delays in the system are over an hour or hour and a quarter. That is the average for the entire fleet into that particular airport. That is how you do a delay analysis. But that doesn't mean that everybody is level at 15 minutes. The delays go up and your peak hour

delays average an hour to an hour and 20 minutes. Maybe Agam wants to add to that.

DR. SINHA: In addition to what Jerry said, a 15-minute average delay per operation is simply a mathematical tool to get at the numbers. The distribution is very wide. You can get up to two hour delays on particular operations or you can get no delay, especially in VFR, for example.

In addition, I think your point about the achieving of projected demand is a very good one. We have conducted some sensitivity analyses there. We have cut back demand 10 percent or 25 percent or 30 percent and seen what effect it has on the delays. What really shows is that even if you cut it back 25 percent you are still operating above the knee of the curve under today's standards. So you're still going to be facing a problem here. Yes, the magnitude of the delay savings would decrease, but it will not go away. And all these will be documented in our forthcoming reports to the FAA.

MR. CHAVKIN: Before I turn over the podium to my distinguished NASA colleague, some questions were raised that I want to try and answer for everyone since we did not get in a lot of detail on these issues.

When you take an economic study that's been run over a year to a year and a quarter, and you've looked at all varieties and sizes of things, and then you put it before an audience on a bunch of view graphs in 30 minutes, some points that you're trying to make don't come out the way you want them to. So I want to try a couple of things. First, you have to understand that when we do an economic analysis for some 20 hub airports, the FAA by our own policies do not restrict the demand. We therefore calculate the total value of the delay. In other words we just let it go as high as it could. That's what we do in our task forces, also. You then see that a 15-minute delay average as an example, could result in an hour, or hour and a quarter peak delays. We let it go. The economic numbers you saw where the delays that resulted

from unconstrained demand delays at 20 hub airports using forecasts for the year 1995. Now, what did we mean by the value of a passenger, the \$50. You know, what we said is let's assume for a minute that in the real world we will not let demand go like that. If the airports are constrained, we will limit the demand. Okay. If you limit the demand there is an economic value to the air transportation system. The \$50 was not an input, it was an output. The calculated value of limiting the demand to approximately a 4-minute delay level, comes out as the economic value of limiting the demand which was about \$50 a passenger. That's all that is meant. And we're not saying it's right or wrong. It's a reasonable number. It's at least what the economists (I'm not an economist) tell us is reasonable. So I hope that clears up the first point. It wasn't an input, it was an output. We let the demand go. We calculated the dollars of delay based on what happened to it. But then if we suppressed the demand to the so-called magic number of 4 minutes, and we don't know if it's 4 or 5 or 5, it's worth about \$50 a passenger. If they divert to another mode and they still travel, it is still worth something to the air transportation system as a system that did not meet this demand.

Secondly, I want to make it clear that why we have 100 percent effectiveness shown on those charts is that's the potential for alleviation. A ground system we know can never get to 100 percent effectiveness. But, if an aircraft with an alleviation device has an airplane following it, no matter theoretically what the weather is, it has the potential for 100 percent effectiveness. So it wasn't meant to point that the ground system was the answer at 40 or 60 percent, but rather the ultimate potential was a 100 percent. Okay?

Now, the third point, and this is a very difficult point. The delay costs are accrued to the operators, the airlines or GA, whoever is using that airport. The delay costs accrue to them and then to their passengers. In fixing the system, if it's a ground system, the costs are government costs. If it's an alleviation

system it could be some combination of the airlines and manufacturers, or for that matter if there's research, the government. Now, historically, obviously, those 100's of millions of dollars of cost are not a cost savings to the government. It is a cost savings, if it exists, to the airline and its passengers. Okay, I think that may answer some of the points that were brought up. If you have other questions Agam and I will be glad to answer them and we'll be around for the workshop tomorrow.

SESSION II
WAKE VORTEX ALLEVIATION - THE
NASA PROGRAM

MR. STICKLE: Thank you, Jerry

You know, it just dawned on me why we went through all this adverse weather to get up here for our meeting. It was easy to precondition us so that we could talk about these air traffic delay studies without our own preconceived biases.

What I want to do is just outline what we in NASA have been doing in the wake vortex minimization program. In doing this I really have two objectives. The first is that in this session I would like to disseminate what we think to be the NASA view of the state of the art in wake vortex minimization. We will be describing the on-going program plans and we will be identifying what we think is additional effort required if one was to consider implementing wake vortex alleviation at the source. The second involves tomorrow's workshop session, which will follow statements made by industry, ALPA, and other user organizations. In the workshop we hope to be able to provide a more integrated state of art assessment and recommend technology requirements for vortex minimization and implementation.

In today's session, I will be giving an overview of the program including some of the background supporting the minimization effort and then Earl Dunham from Langley will discuss the technical programs and results. I'd like to emphasize here that the results that Earl will be talking about are the culmination of a lot of effort that has gone on from other centers, both Ames and at Flight. It also involved several contractors including the major airplane companies, consultants, and universities and many of the people right here in the audience. So without trying to go through all the recognition for those involved, I will simply refer you back to the wake vortex symposium held in Washington in February of 1976. The contributors are listed in the proceedings.

Following Earl's talk, Joe Tymczyszyn, will give pilot comments of what it's like flying in an alleviated versus an unalleviated vortex. I think those comments will be particularly pertinent to the talks and provide some credence to what we've been doing in the minimization work. I've just been told that

WAKE VORTEX RESEARCH

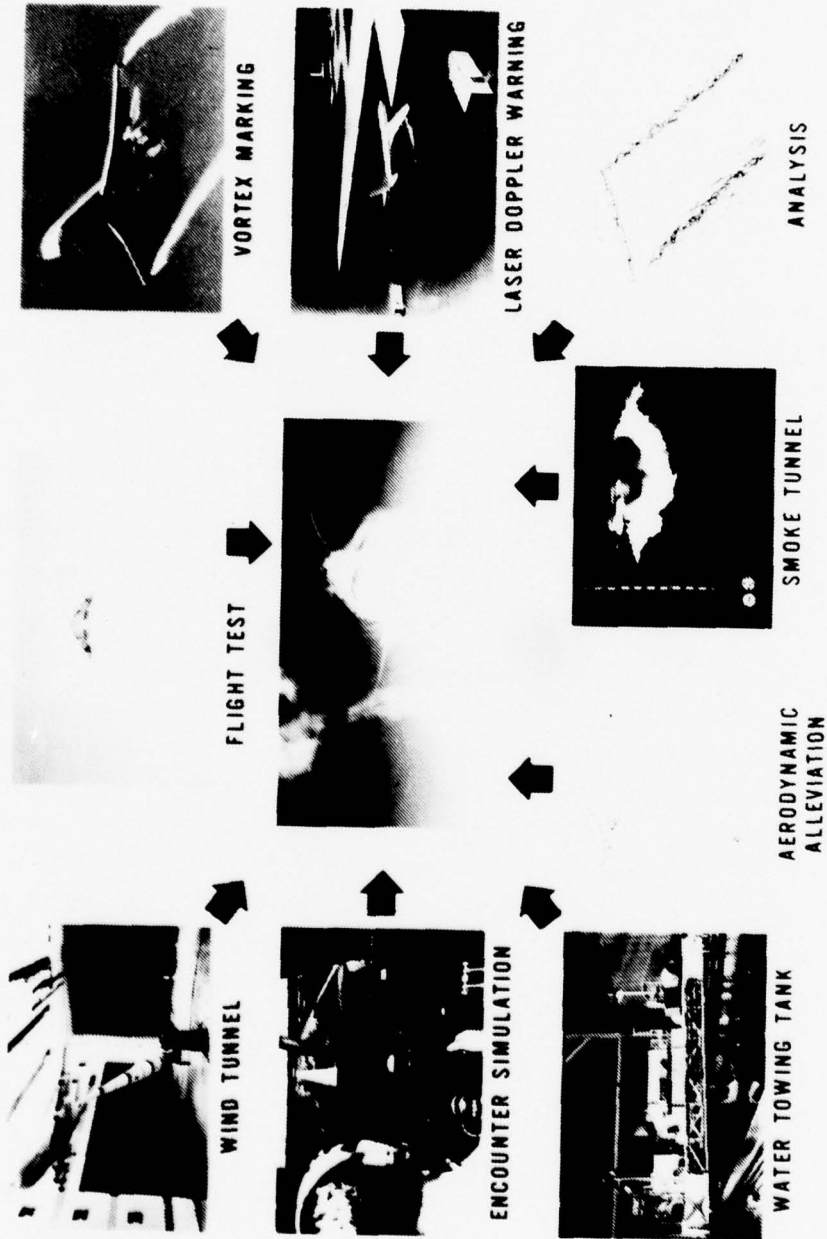

NASA HQ REPORT-10056 (S)
1-21-75

ELEMENTS OF NASA'S WAKE VORTEX RESEARCH.

Russ Barber is going to have a film that will introduce Joe's talk so he will be the first speaker. Russ Barber is from our Flight Research Center and he's been the vortex program manager out at that center for the last seven or eight years.

Al Gessow from NASA Headquarters will wind up this session with a discussion of what our plans are today and what he sees as requirements for future implementation.

The point that I want to begin with is that for about 20 years, from 1950 to 1971, NASA has been involved in what we call basic vortex research. The objective was to try to understand how vortices were formed, how they moved in the real atmosphere, and how to visualize what the vortex structure was. The analytical tools that we had in the early days were largely empirical data fitted to the vortex roll up, its path through the atmosphere, its persistence in and out of ground effect. Those analytical tools were often applied but did very little to lead the researcher toward altering the vortex structure. Some of the auxiliary efforts that were ongoing in the early 1970's involved development of vortex marking systems to support the Flight Research Activities. The systems most often used were either corvis oil systems or chalk dust. The last couple of years we have been working with the Jet Propulsion Laboratory on a concept of using an ethylene glycol solution added at the jet exhaust to illuminate the vortex much like it was in the days when we had smoke in the engines. You could see pretty well the vortex path of the old smokey aircraft. JPL was persuing this approach on the basis that if a solution to alleviating the vortex could not be found then maybe there was a way to illuminate the vortex in an operational environment that would be environmentally acceptable.

About 1972 the joint NASA/FAA program was initiated and that was where we really started putting the emphasis on minimization research. At that time there were a number of concepts that had been proposed to NASA and to the FAA which offered promise of being able to minimize the vortex or alter the vortex structure. Some of these were supported by very limited wind tunnel tests.

Some by simple analysis and some were just way-out ideas. Our first task was to set up an evaluation program in which we could systematically run through the ideas. Four evaluation facilities were used, three of which you'll see in a short movie that follows. The fourth facility was the Ames 40 by 80 foot wind tunnel which is shown in this slide. In order to compare results, all four of the facilities used a standard model and test technique. Generating the vortices was a 3 percent scale 747 model (about a six foot span). We actually create the vortex in the tunnel, let it proceed downstream, and impact a small scale model of a wing representing a following aircraft. The following model uses a roll balance to measure the rolling moment upset.

Before we see the movie, there are two more points I'd like to bring out. The first involves the effect of a vortex on helicopters. About 3 years ago NASA researchers flew an UH1H helicopter into the wake of a C-54 airplane. As far as I know, this is the only test of vortex encounters of a helicopter in an airplane wake. In this test the UH1H had no difficulty in operating at very close separation distances (less than one-third of a mile) behind the C-54. This was a very limited test and does not resolve the overall question of the hazards of operating helicopters in close proximity to larger airplanes.

The second point to bring out here is that all of our tests to date in flying behind airplanes with alleviated vortices have been done at an altitude of roughly 5,000 to 12,000 feet above the ground. The big test of vortex minimization comes into place when you're landing behind an aircraft, in which case you have to consider the effects that ground proximity has on the alleviation. The emphasis of the program this year will be to develop the confidence to land the following airplane behind the generating aircraft at a reduced separation distance.

Now, can we have the movie, please? What you will be seeing in the movie are some shots of three of the facilities that were used in the program and some of the flight tests. This sequence

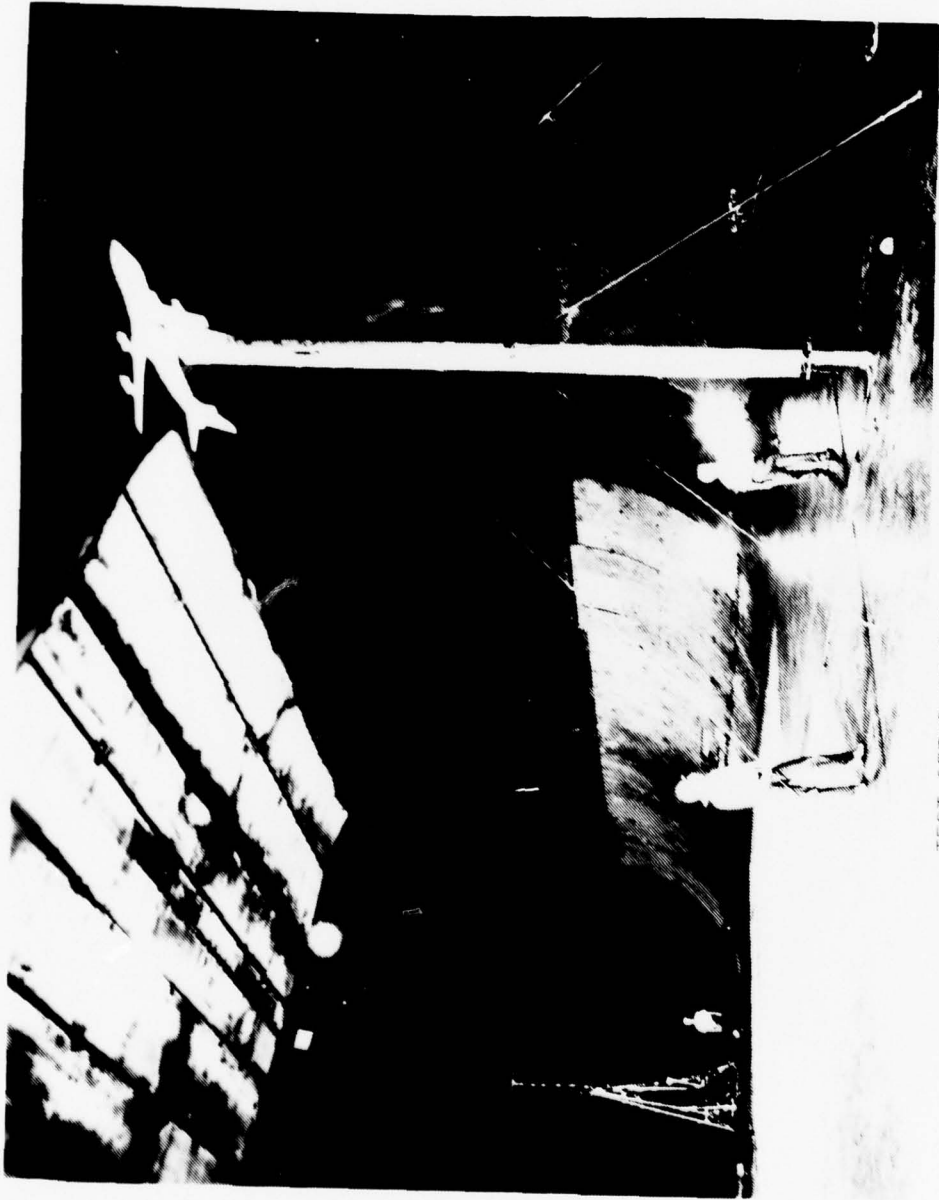

TEST SETUP IN THE 40- BY 80-FOOT WIND TUNNEL
AT AMES RESEARCH CENTER.

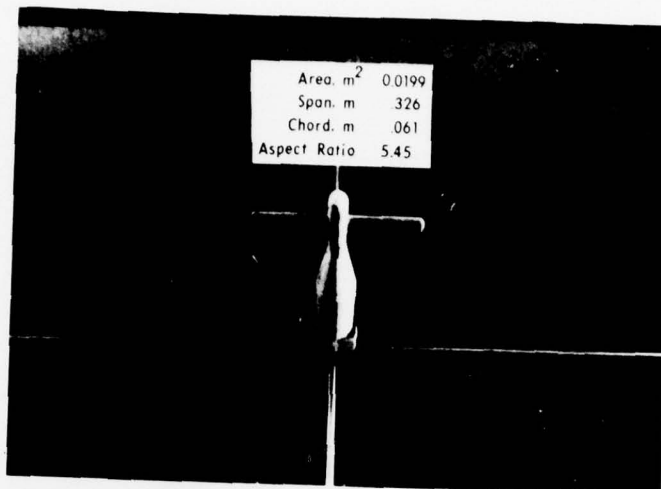

L-75-2411.1

(a) Small trailing model.

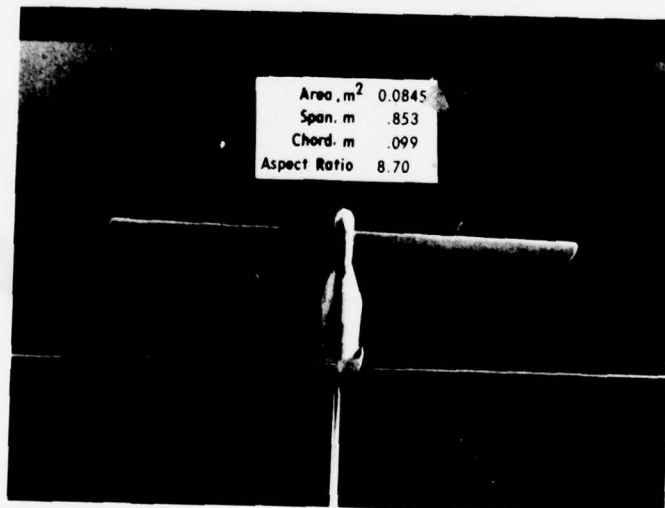

L-75-2412.1

(b) Large trailing model.

PHOTOGRAPH OF FOLLOWING MODELS USED IN VORTEX
 ALLEVIATION TEST FACILITIES.

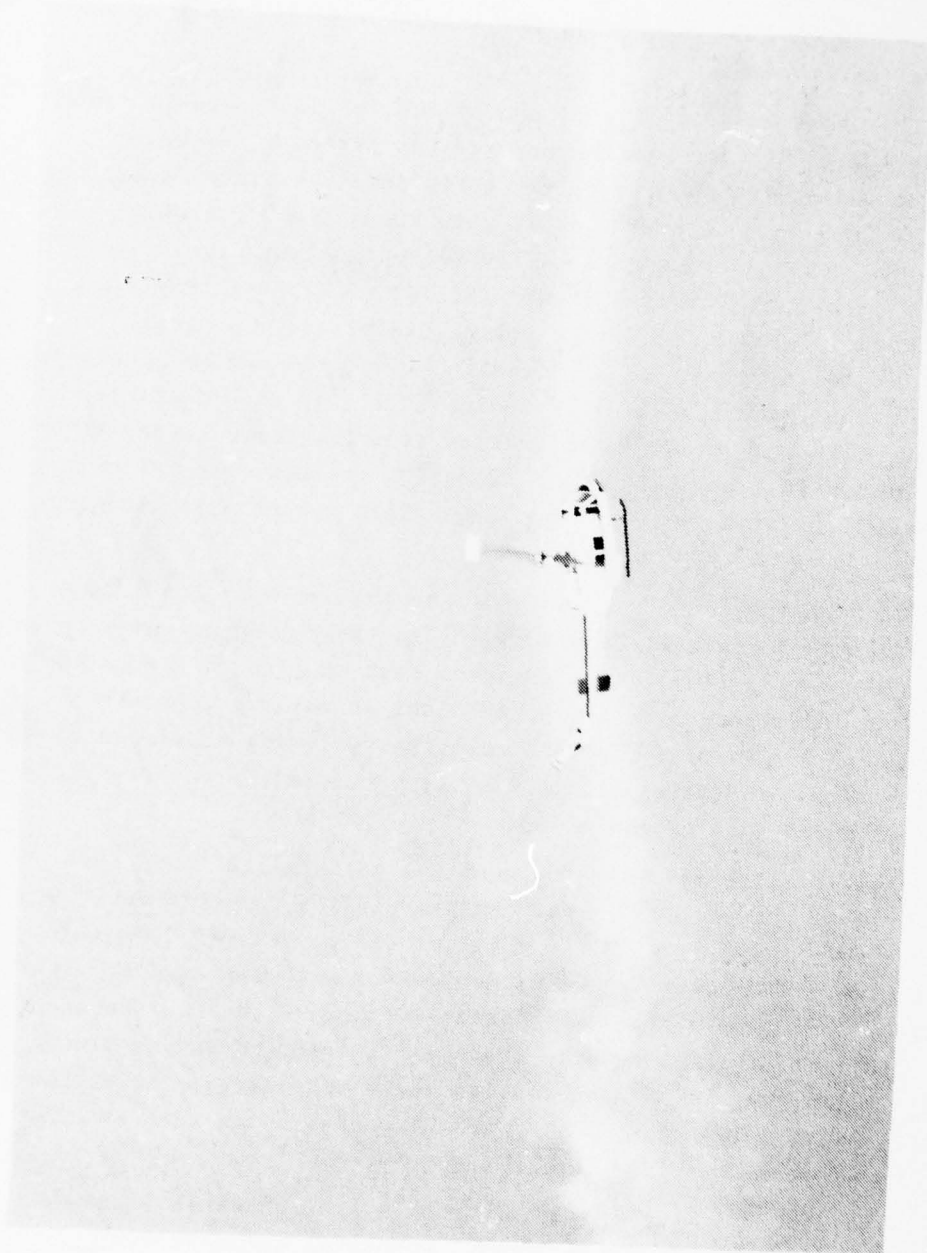

UH-1H PENETRATING VORTEX OF C-50 AIRCRAFT,

shows the V/STOL tunnel. The vortices are illuminated by smoke and you can see the characteristic meander that you find in the natural environment.

This next sequence is of one of the following models. And during the evaluation program we used two sizes of following models, one which would represent a Learjet-size aircraft and the other a DC-9-size aircraft. This view shows the 747 model. The following model is mounted on a remote controlled survey rig. This shows the vortex flow facility at Langley. This facility was developed specifically for the vortex minimization program. We use the same technique of a generating and following model except that in this case the air is standing still and the models are moving. The test track in the vortex flow facility is 1800 ft long and the models reach a speed of about 100 ft/sec. The following model is separated at a distance equivalent to one mile in full scale.

This next sequence shows the water tank at Hydronautics, Incorporated in Laurel, Maryland. Again the following model moving as in the vortex flow facility except that the two carriages in this case are independent so that we can look at various separation distances very easily. In this case the following model can go back to about 2.5 miles (scale distance) before the vortex system has descended into ground effect.

This next series shows some of the early flight work done on the C-54 at our Wallops Flight Center. This shows that you could take off in the C-54 with these 7 foot spline devices deployed. They were really drag-producing devices used to insert drag right in the core of the vortex to enhance its decay. We flew behind the C-54 with a single engine Cherokee airplane as shown here. The airplane was instrumented so we could measure rolling accelerations and calculate the rolling moment. That shows what the vortex system looks like behind the C-54.

The pilot flew up into the vortex system which is illuminated in this case by chalk dust. You'll notice in the case with the alleviation on there is very little upset.

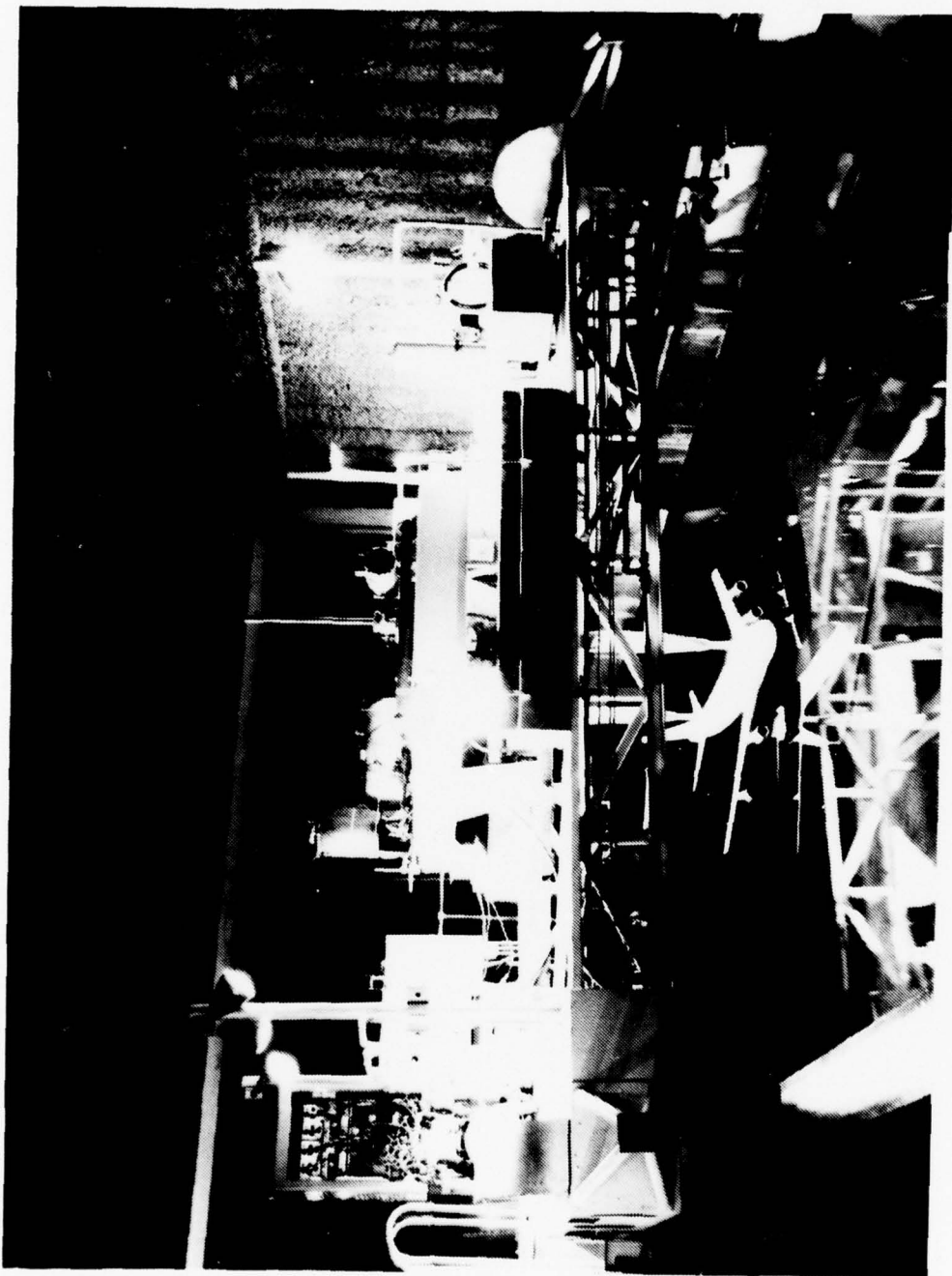

GENERATING MODEL AND CARRIAGE SYSTEM FOR WATER TANK
TESTS AT HYDRONAUTICS, INC.



VORTEX VISUALIZATION SYSTEM ON C-54 AIRCRAFT

At Dryden Flight Research Center, NASA, the FAA, and the Air Force have tested all the jumbo jets, (the C-5's, 747's, DC-10's, and 1011's). This shows the smoke system used on the 747. Penetrations were made with a Learjet and a T-37. This sequence shows three smoke generators on each wing illuminating the vortex structure behind the airplane. There was no alleviation in this particular case. This was just the normal landing configuration.

This shows what it looks like flying behind in the vortex structure at a relatively close distance behind the airplane. This is inside the normal separation distances but you'll notice that you get rather large upsets once in a while.

This is the T-37 which was also used to probe the vortex and you'll notice that he just went through again at a very close separation distance.

I would like now to turn the podium over to Earl Dunham who is going to give you the results of the program. Earl is from Langley. He works in our Safety and Operating Problems Branch and has been working in the vortex area for about seven or eight years.

MR. DUNHAM: Well, as Joe stated the basic purpose of my presentation is to describe to you the technology of wake vortex minimization or what we know can be done to achieve a reduction in the rolling upset behind the aircraft.

Let me start with the first slide. Basically we can minimize the vortex wake by enhancing its natural decay process. There are two principles for doing that. One is by controlling the distribution of vorticity along the wing, thereby controlling the lift distribution or the span load -- altering the span load of an aircraft. Besides controlling the distribution of vorticity, another means is controlling the distribution of drag within the wake. You must recognize it is somewhat difficult to separate these two. Any alteration in the span load is probably going to change the drag distribution as well as the lift distribution.

Let me describe how I laid out my talk, because I cover several areas of research from various centers with lots of different people involved. Let me talk first about the turbulence production, a little bit more about the spline device that Joe showed in the movie. The spline device is one which basically changes the drag distribution behind the aircraft. It places a large slug of turbulence in a region which is effective in minimizing the wake vortex. Now a way of altering the span load distribution we looked at is to modify the flap deflection. We thereby control the position of the wing tip and flap vortex, the relative strengths and the manner in which they interact downstream.

As I said, it's difficult to separate drag distribution from span load alteration so you have two concepts that I would like to describe to you which really combine the effects of changing the lift distribution and changing the drag distribution; one of them being a concept developed by Vernon Rossow at the Ames Research Center, which we call a vortex fin, and the other one is the use of the spoilers on the aircraft and that work was done by Del Croom. Those first three subjects cover the experimental program and then the final phase of my talk covers some of the analytical work that we have done.

Now, looking again at the spline device, as you saw in the film, it was effective in minimizing the vortex wake. The PA-28 could approach as close as a quarter of a mile behind the C-54 aircraft in a controlled state. Without the device it was limited to something like 2 or 3 miles before he ran out of the roll control capability of the PA-28. Some work has been done on implementing such a thing on a 747 model. As Joe pointed out the drag penalties are enormous. In addition, there would be a major hardware modification required to implement such a concept.

Now, since we've already seen a film on this let me run through briefly what we know about turbulence injection. The spline device in the C-54 flight test was our first confirmation that we could do something to the vortex wake and that we could reduce the rolling upset. While the drag penalties associated

with the splines would probably prohibit their operational use, there are other methods to add turbulence to a vortex system. The turbulence produced by the engines and the turbulence produced by landing gear are two examples. The knowledge that we gained about the turbulence effects is going to be useful in future aircraft designs when it comes to where you place the engines in relationship to the main vortices that are generated on the aircraft, and the turbulence from landing gear and other turbulence-producing devices on the wing and their positions are important.

Now, let me go to the other concept, which was altering the lift distribution or span load alteration. Shown here is a 747 model in the V/STOL tunnel in its normal landing approach configuration, with all of the flaps deployed to about 30 degrees. The slide to the left shows the 747 model with the outboard flap retracted. What we're attempting to do is to control the interaction between the wing tip vortex and the main flap vortex by changing its position and its relative strengths. If we take a look at the results of doing this, as shown here, the rolling moment as measured by the following model technique that Joe described, as a function of scale distance behind the 747 model, all the data are for the same lift coefficient. Obviously, a higher angle of attack with the outboard flap retracted is required. Plotted are the rolling upset in the standard flap configuration as shown by the circles, versus the rolling upset when we retract the outboard flap. We noticed that initially there is not a large change in rolling upset. This is because we think that this concept basically relates to the development of the wake and its interaction with the wing tip and flap vortex. The process that is going on has not fully developed its destructive nature until further downstream. You see that there is a reduction in rolling upset of at least 50 percent.

Now, this concept has been flight tested. Shown here is the 747, with smokers installed in a standard landing approach configuration. A nice concentrated pair of vortices. The flap and tip



PHOTOGRAPH OF TEST APPARATUS IN V/STOL TUNNEL.



2-17

vortex wrap-up and interact very early, about a span behind the aircraft.

Now, comparing that to the configuration to the left, which is with the outboard flap retracted, you notice that the interaction between the wing tip and flap vortex is considerably delayed and this interaction process enhances the turbulence production between the two vortices, and the final wake that is formed is reduced significantly in strength. The flight test results tended to confirm the model test results in that the rolling upset at the same lift coefficients between unalleviated and alleviated case was reduced about 50 percent.

I'd like to point out that this set of flight tests also taught us some interesting things about controlling the interaction of vortices. Initially the model tests were done with landing gear retracted. So we did the initial flight test with the landing gear retracted. We found that when the landing gear was lowered, a considerable portion of the minimization that had been achieved was lost. And the reason for that, is an additional vortex at the wing-fuselage junction. The landing gear turbulence interfered with this vortex. This vortex had an impact on the way the tip and flap vortices interact with one another. Additionally, the minimization that was achieved could be reduced by side-slipping the aircraft. Also the aircraft was not intended to be flown in this mode so there were considerable performance penalties associated with it. I think we had restriction on the forward C.G. limit.

Let me sort of summarize what we found out from the vortex interaction work. Controlling the distribution of vorticity along the wing is an effective method of controlling the vortex upset. Now, the way we implemented it on an existing aircraft is probably going to be impractical. The knowledge is beneficial for future aircraft designs and understanding the control or interaction process, as well as understanding the placement of wing tip and flap vortices. When I talk about some of the analytical work that we've done, I'll demonstrate this particular point again.

Now, let me move on to the two concepts that I talked about which combine the turbulence and span load alteration. One of them is the vortex fin, the work that was done by Vernon Rossow. The fin is vertically positioned on the wing. The drawing shows a rectangular fin but he's tested several types. The one that's illustrated in the photograph is a semi-circular fin. These are side force generating fins in the sense that they are lifting surfaces. They produce a vortex and the effort here is to produce a vortex which will influence the interaction phenomenon between the tip and flap. Also the fins produce turbulence, too. So they add to both the turbulence and the wake and to the vortex interaction process.

Model tests have been done of this configuration. I'll show one of the results of these model tests a little bit later on. But basically it does reduce the rolling moment by at least 50 percent.

Now, another method, which is probably what we've found to be the most effective method for reducing the vortex wake is by selectively deploying several spoilers on the aircraft, and I've numbered them here on a 747, one, two, three and four on the outboard end. Shown on the next vu-graph for illustration purposes are the spoiler segments. Del Croom has done considerable work in the V/STOL tunnel and he's done a parametric evaluation of the various combinations of spoiler deflections and deflection angles and the influence that they have on the downstream wake characteristics.

Now, let me sort of summarize the basic results of the spoilers with the use of this chart. Plotted on the vertical axis is the induced rolling moment where I've ratioed the modified vortex rolling moment versus the basic aircraft configuration without vortex modification. And as sort of a figure of merit I've plotted the data as a function of the percent of drag increase. All this data was obtained for a 747 model; all at the same lift coefficient. The circles represent various combinations of flight spoilers. I've just picked off a few of them here for interest.

If we deploy all of the flight spoilers to their maximum deflection angle of 45 degrees, we get a significant reduction in rolling moment but it costs us a tremendous drag penalty. Consequently, if we deflect only one of the spoilers, No. 3, at a very low deflection angle of 15 degrees, we don't achieve much rolling moment reduction or increased drag.

Now, obviously, what one would like to have in terms of the golden egg would be to make the induced rolling moment zero, at zero drag increase. Also, I've shown on here the spline device, it's drag increase and it's rolling moment for the 747 model, and the Rossow vortex fin as shown here. Two other spoiler configurations which I think are worth noting are spoiler configurations 1 and 2 at 30 degrees, and spoiler configurations 2, 3 and 4 at 15 degrees. Spoiler configurations 1 and 2 at 30 degrees were flight tested and I'm certain that Joe is going to talk a lot about that particular case and the flight test results. The 2, 3, and 4 spoilers at 15 degrees is a configuration that was recently investigated by Del and we hope to flight test it in February. You notice that it comes very close to driving us towards the optimum point.

I did mention that the spoiler configuration has been flight tested, 1 and 2 at the 30 degrees deflection, and has shown significant rolling moment reductions. As Stickle mentioned we have yet to land behind an aircraft with an alleviated wake however the spoiler configurations that we're looking at now - 2, 3 and 4 at 15 degrees - do show some promise.

Now, the majority of the spoiler work has been done on the 747 model. Del has done some additional model test work with a DC-10 and L-1011. These were cooperative efforts with the manufacturers in helping us by providing the models, and Del has found that there are spoiler combinations on the DC-10 and L-1011 which will reduce their vortex wakes.

Additionally, some preliminary flight test work was done on the L-1011 to confirm the model test results.

I'd like to summarize the combination effects, that is, altering the span load distribution, and enhancing the drag within the wake. Our understanding of exactly which mechanism is predominant in the spoiler case is not very good. We know it enhances the drag and turbulence and we know it changes the load distribution. The vortex fin is going to require considerable modification to implement on an aircraft. However, the device may have use as a side force generator. Additionally, there's some work going on right now at Iowa State to enhance the effect of the fin while maximizing its penalties. We have established that there are certain spoiler combinations that were effective in reducing the vortex wake. Now, the spoiler performance penalties are not inconsequential, but they may be acceptable. Additionally, it's worth noting that that type of device causes a drag increase that can be easily recovered. You know, slam the spoilers down and you've got all your CL-Max capability back and you have reduced the drag and you're in a better state. We have shown that the spoiler concept is applicable to existing aircraft and generally takes minor hardware changes. In some cases you have to change the hydraulics a little bit, or maybe the electrical system. The information that's been generated indicates the positioning and design of spoiler systems on future aircraft should probably consider their use for vortex minimization. We also believe that presently the use of the spoilers is a most promising concept for existing aircraft. We had a manufacturer take a preliminary look at the feasibility of employing spline devices or a drag device, span load configuration and the spoilers on a 747 aircraft. The spoilers tended to have the most promising results.

To sort of finish off and describe what we are doing in our experimental program, I would restate that our understanding of the relative importance of drag distribution and vorticity distribution along the wake, especially with regard to the spoilers is not very good. We have a specialized model that we're employing in tests right now, from which we can alter the twist along the wing, thereby changing the load distribution, and go downstream and measure rolling moments in the wake and use hot wire

anemometers to measure the wake itself. We can put spoilers on the wing, and try and obtain a better understanding of the basic effects of span load distribution and drag distribution.

Additionally, this particular model is going to provide some useful data for verifying analytical techniques. As Joe mentioned earlier, the initial analytical work involved inviscid studies of the wrap-up of the vortex wake into a vortex pair and the basic movement of the vortex through the atmosphere.

Now, we know that turbulence plays an important part and the viscous decay of the wake is important to understand. Under a contract with Aeronautical Research Associates of Princeton, a computer code has been generated that is a viscous modeling of the vortex wake. I just want to show you some of the results of that computer code without describing it in any particular detail. What I've plotted here is the induced rolling moment on a following aircraft as a function of the spacing between the flap vortex and the wing tip vortex. And I've done it for the ratio of vortex strengths of tip vortex to flap vortex at a value of two, and of equal strength. And you see that by varying the position of the flap vortex, all this done at the same lift coefficient, you change the rolling moment considerably. Now, these results do not exactly correspond to real world conditions, but this particular point is comparable to the landing approach configuration of the 747 with a flap vortex almost twice as strong as the wing tip vortex and you get a large rolling moment and the other case here corresponds to removing or retracting the outboard flap and positioning a vortex here and here both of nearly equal strength. The computer code predicts a large change in rolling moment. The computer code being a viscous modeling is also capable of handling the interaction of the vortex with atmospheric phenomena, turbulence in the atmosphere, wind shear in the atmosphere and the influence of the ground plane on the vortex itself. Shown here is one vortex, for various non-dimensional time steps of a vortex descending down and moving across the ground and interacting in a viscous manner with the boundary layer. It was found that in this case there is some

change in the flight and the movement path of the vortex, and also the decay of the vortex is considerably enhanced.

What I've basically shown on the left is the vertical position of the center of the vortex as a function of the lateral position in terms of semi-span. The solid curve represents the centroid of this vortex as it marches through time. The dotted line shows the predicted path for an inviscid model and the influence of the ground plane is to change the position considerably. The scaling factor for a 747 between this non-dimensional time and the real world time is about a factor of 10, since 40 represents 400 seconds.

Let me summarize now our analytical efforts. Preliminary results indicate that the computer code that we have, although not fully verified, is useful for predicting the vortex wake character. This code is available for use now by the manufacturers. One company does have it and is making some calculations using this code. I failed to point out one of the limitations of the code. The code starts at the trailing edge of the wing and given a set of initial conditions of the flow field at the trailing edge it develops the downstream character of the wake. Somehow we have to have that initial condition. It can be estimated or measured in some of our model tests. The code only works one way. It can only take the conditions at the trailing edge and tell you what the wake character is downstream, given a wake character downstream you really can't go upstream with it and determine what type of wing load distribution and drag distribution that is required to give you that wake.

Now, the requirement for a detailed trailing edge condition is under investigation with the variable twist wing that we have. It may be sufficient to use existing lifting surface paneling techniques to predict the trailing edge conditions and make some empirical estimate of the turbulence or it may be required to have a very detailed description of the trailing edge conditions behind an aircraft in order for the code to provide useful results. That question hasn't been answered yet.

Let me summarize my presentation. Significant wake vortex alleviation has been demonstrated. We did it with the spoiler work and with other flight test work. We think we made some advances toward a solution that's applicable to the current aircraft fleet. I'm talking about the spoiler work. We think we have analytical tools that are available for the designer in aiding him to evaluate what vortex wake is behind any configuration.

MR. STICKLE: Okay. Before we go into the other session which will carry the pilot comments and everything, are there any questions that you want to bring up now?

If not, we'll get into the interesting part.

Joe? Joe's going to tell you what it's like to be back there. I'll let you introduce Russ.

MR. TYMCZYSZYN: I've asked Russ Barber, a fellow I've worked with for a good many years to introduce this session and I have an ulterior motive there. Anything that he introduces lends credibility to what I have to say about it. So, Russ, I wonder if you will start the program off.

MR. BARBER: Having worked at the Dryden Flight Research Center for several years now, in fact, my entire career, I frequently get asked to help the pilots with their comment sessions.

We're going to talk about those systems that have been verified in flight. They're listed there, conventional flaps, splines, the 30-1 flap configuration. We're going to talk a little bit about a 5-30 flap configuration that actually augmented the wake. And finally, the spoilers that we have flown on both the 747 and L-1011.

I've got a short sequence of film here which will illustrate the attenuation, I think, rather graphically. We'll show you that and then Joe can talk about the pilots' impressions.

Could I have the film, please?

The first sequence of film here will illustrate the effect of flaps on altering the wake of a basic airplane. This is a 727 flying with the flaps up. Note the wake on the right wing here.

FLIGHT VERIFIED ATTENUATION METHODS

- o CONVENTIONAL FLAPS (ALL AIRPLANES)
- o SPLINES (C-54)
- o 30-1 FLAPS (747)
- o 5-30 FLAPS - AUGMENTATION - (747)
- o SPOILERS (747 AND L-1011)

He ran out of smoke on the left wing. Pay no attention to that. Here he is extending the flaps, and what you'll see as the flaps come down is that this wake changes from relatively small type of cord wake to a much more diffuse flow pattern. The flaps are coming down now, you can see the wake bending down. It's obviously fortuitous that flaps in themselves have this effect on the wake in that if we didn't have this amount of attenuation we would probably be living with separation distances of 8, 10, 12 miles, because the clean wakes are much more uniform and much more upsetting to a trailing aircraft. You see an obvious difference there from when the sequence first started.

Joe had mentioned the splines. I've got a sequence of film here that shows the wake of the basic C-54, that is, with no splines. You see the real tight core. I'll mention here that the splines were mounted on the wing tip of the C-54. That was done for simplicity of the test program. Any of the work that we've done we've realized that the dominant vortices off of the heavy transports are shed at the outboard edge of the outboard flap and therefore, to be practical, the splines would have to be mounted there in any kind of an application. But you'll notice the difference in the wake here as compared to the previous sequence. Again, a much more diffuse flow pattern.

Joe Stickle and I didn't get completely coordinated and this is the same sequence of film that he illustrated where of the PA-28 would be upset at about 4.5 miles, with the basic airplane, whereas it was able to fly under 3/10ths alleviated.

That was the basic 747 in the 30-30 flap configuration. The wrapped up vortex system is here and I'll show this for a period of time to give you some feel for the persistence of it. In the next sequence of film will be a flyover in the 30-1 flap configuration. And in that configuration you can actually see the interaction of the wing tip inboard flap vortices that Earl talked about previously and the decay. The photographer pans back downstream here and you can see that this wake is still persistent in the distance.

Okay. Here's the 30-1 flap configuration. Totally different flow pattern in the near field and as the airplane goes overhead I'll try to point out the interaction to you. You can see the tip vortex is off by itself, it rolls up and over the vortex shed by the flap. And then as they merge, a destruction starting to occur between the two systems. What this did is actually destroy the vortex at a much closer distance to the generating airplane.

Okay. This again is the 747 in its basic landing configuration, 30-30 flaps, gear down. We had an improved smoker system on there so you see much more of the total flow pattern behind the airplane. But you see the dominant trail vortices, the combination of the wing tip and the outboard flap, remaining about the same in the rest of the flow. Actually they bound this total flow condition. These were tests that were done at Rosamond Dry Lake. TSC had their laser van out there and we actually made flow field velocity measurements.

Note that the airplane has turned out of the field of view and we still have a vortex prevalent as compared to the configuration with the two outboard spoilers extended. This is the same day, just a few minutes after the previous one. And you never see the wrap-up of the type vortices that you saw in the previous configuration.

The point of all this is visual evidence that we are significantly altering the wake both in the near field and the far field. He hasn't even begun his turn yet, or just begun it, and the visibility at least is all gone.

To illustrate what this looks like at say a 5-mile distance, this is the DC-10 wake in some very early flight tests in a clean configuration. And you could see there how small the core was, how tight, as contrasted to the landing configuration at 5 miles. We still have upsetting energy there but the character of the core is much different.

I'll give it back to Joe.

MR. TYMCZYSZYN: Thank you very much, Russ.

CHARACTERISTICS OF 30-1 FLAPS

BASIC 747 (LANDING CONFIGURATION)

WAKE PERSISTS TO 6-7 MILES

UNCONTROLLABLE EXCURSIONS AT 4.5 MILES
OR LESS ($\phi > 180$)

30-1 FLAPS

WAKE NOT DETECTABLE BEYOND 4 MILES
(GEAR UP)

T-37 CONTROLLABLE TO 1.8 MILES
($\phi < 30$) $C_L 747 = 1.2$

$C_L 747 = 1.4$ WAKE AT 2.5 MILES APPROXIMATES
BASIC AIRPLANE AT 5 MILES

LANDING GEAR DISAPPOINTINGLY REDUCED
ATTENUATION

Everything you've seen up to now has given you the history of wake turbulence attenuation or alleviation. My comments this afternoon on our certification, operational and environmental problems will be only related to the latest configuration.

For the purpose of continuity, I would like to pick it up at the splines, just very, very briefly. This work was flown by Bob Champine at Langley and I think Earl and Russ have already said that it was a problem in controllability for the little Cherokee at 2.5 miles behind the C-54 in a normal configuration and they had a controllable airplane down to 3/10ths of a mile with the splines installed.

One reason for thinking about this is that even though we're so excited about attenuation with spoilers, we want you to keep thinking about the fact that when the time comes that its cost benefit studies show that you must also work on an attenuation for take off and departure, a technique such as this may not be entirely out of the question.

Now, we're going to talk about the 30-1 flaps. We've seen pictures of that before and it was our very, very first successful attempt at seeing sizable attenuation with a relatively simple airplane change although it would not be a very practical airplane configuration. First of all, I want to summarize it by saying that in a normal configuration the wake persists 6 to 7 miles and that for any separation distances over 4.5 miles you have absolutely uncontrollable excursions; therein lies the 6-mile separation of today.

When we went to the 30-1 flap configuration, which really just changed the span lift distribution, we could not find a wake beyond 4 miles. And we might mention that there were literally dozens and dozens and dozens of penetrations both parallel and cross-track looking for it. We worked our way into 1.8 miles in this configuration, at a Coefficient of Lift (C_L) of 1.2, which is approximately 15 knots above normal landing approach speed, and we had an absolutely controllable airplane at 1.8 miles. Now, at 1.4, which is akin to the 1.3 times the stall speed or the

CHARACTERISTICS OF SPLINES

BASIC C-54 (FLAPS UP)

WAKE PERSISTS TO 5 MILES

PA-28 - UNCONTROLLABLE ROLL
UPSETS AT 2.5 MILES OR LESS

C-54 WITH SPLINES

WAKE PERSISTS TO 4 MILES

PA-28 CONTROLLABLE TO .3 MILES

reference speed which in the case of the 747 is 142, 144 knots at gross weight. We had the same characteristic controllability at 2.5 miles compared to the basic airplane at 5 miles. There goes your one-half distance that Jerry was talking about. After a lot of flying, I've come to the conclusion that we can achieve half that distance.

Now, because the wind tunnel model did not have a landing gear on it we did all of our work with the gear up, then we put the gear down. We found that we lost part of the attenuation, not all of it. That was obviously a disappointment. But to be practical about it, it wasn't necessarily the most promising practical configuration for the B-747 anyway. This is a plot of the rolling moment coefficient imposed on a T-37 with the pilot effort removed and you see that at distances beyond 4.5 miles you still have some pretty big control problems. This shows that we found nothing beyond 4 miles for the alleviated configuration and yet quite a bit of scattering. There are two ways to measure this, one is qualitative the other is quantitative, which is the best. The second is with rolling moment coefficients, which are required in order to maintain continuity and correlation with wind tunnel tests. We also use roll acceleration and roll control power of the airplane, and also bank angles. But in this particular case, we have one dominant difference, the aerodynamicists might look at this and say you've got a problem here at 2.5 to 3 miles. You really haven't solved anything. But look at it from the pilot side. At 4.5 miles, behind a B-747 or a L-1011 for that matter, you enter the wake and before you know what hit you you're out of it, you've been flipped, 180 degree roll or more. You're out of it. You really don't have time to respond. In these cases, many of these exposures are 8-, 10-, 12-, 15-second wrestling matches. It's beautiful. You get in there and you just have more darn fun. It's just like an arm wrestling match. You are using the T-37 or the Learjet as a torque wrench to stay in there. So the time difference of exposure is not reflected in a rolling moment

747 WAKE VORTEX UPSET POTENTIAL

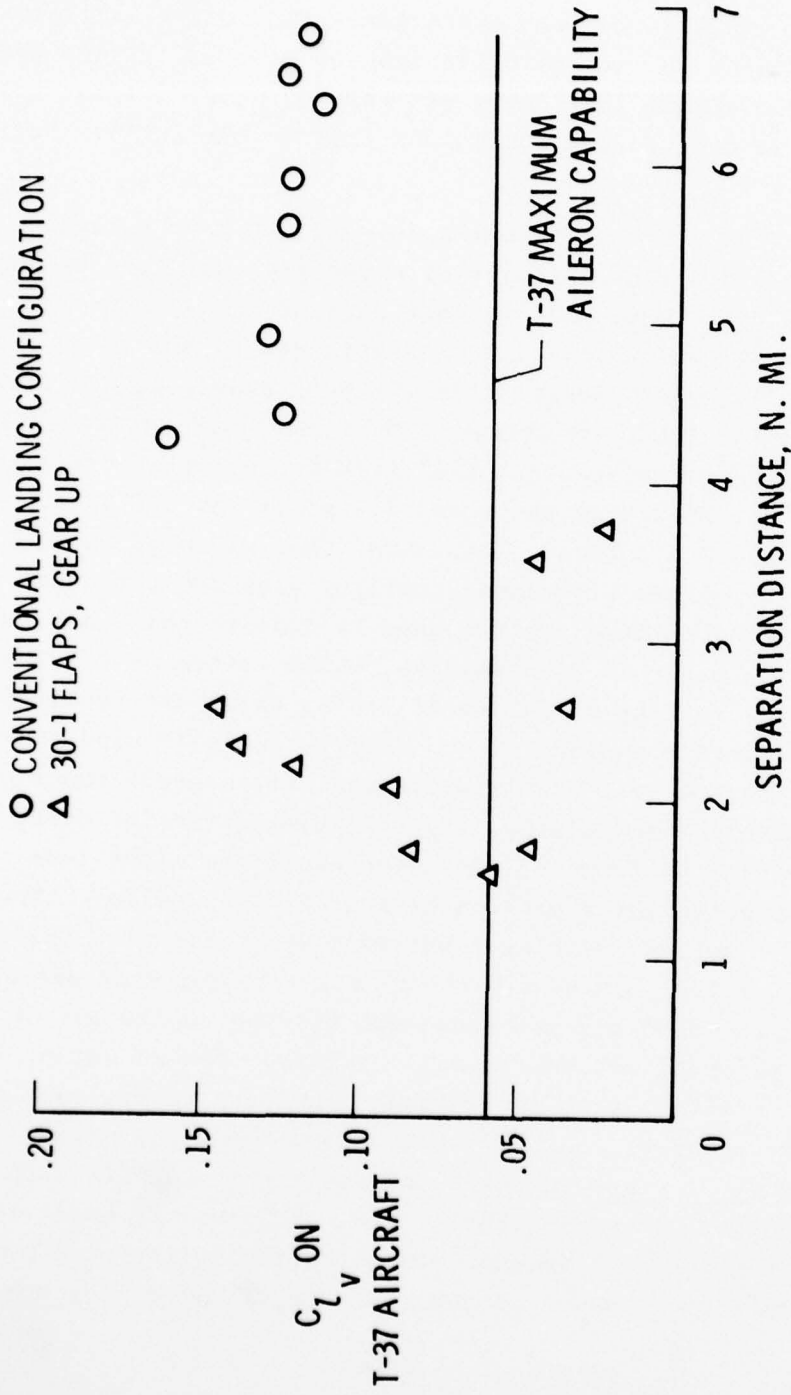

coefficient comparison. But to summarize it very quickly, we say we're getting about the same level of controllability at half the distance, and I think that's significant.

The 5-30 flaps -- I am very proud of this because it is an absolutely useless configuration and Boeing has quite a bit of difficulty proving something as dumb as that. But if there is anyone in 1978 that doesn't believe that you can make small changes to an airplane to achieve attenuation, this is the test that will absolutely prove it. If in fact you can get vortex attenuation or alleviation by changing span load distribution one way, why not try it at 180 degrees apart and see if you can get augmentation. We indeed did. As we entered the wake behind the right wing of the 747 at 4 miles, it was small and tight and I think we might say here from a pilot's viewpoint, we have beautiful correlation between what that wake looks like and what is going to happen to you. Almost direct correlation. At 4 miles we got such a loud jolt that we decided to make a 360 degree turn and pick the vortex up at 6 miles. At 6 miles we did a double inverted snap roll, the right engine flamed out and we had the most violent maneuver from there, and loss of the right engine.

This is a picture of the two sets of vortices from the ground. The airplane is flying 1,000 feet above us. This is a 5-30 configuration and this is the augmented configuration. Again, I ask, who needs augmentation. But there is pretty good visual proof that you have a problem and the spectral density or the optical density, as I say, does seem to correlate with what's going to happen to you. Compare that with the normal 30-30 flap configuration, or normal landing configuration, and you can say that if you can alleviate or attenuate you can also augment if anyone has any use for such a useless piece of physics.

Okay. Next set of view graphs, please. This is 20 seconds downstream. All you have to do is fly in that, underneath, the one on the left, the augmented vortex would really clobber you. The one on the right is the normal one.

CHARACTERISTICS OF B-747 5-30 FLAPS

VORTEX AUGMENTED

SMALLER CORE THAN BASIC AIRPLANE

T-37 PROBE AT 6 MILES-DOUBLE INVERTED
SNAP ROLL, ENGINE FLAME OUT

WHO NEEDS VORTEX AUGMENTATION ???

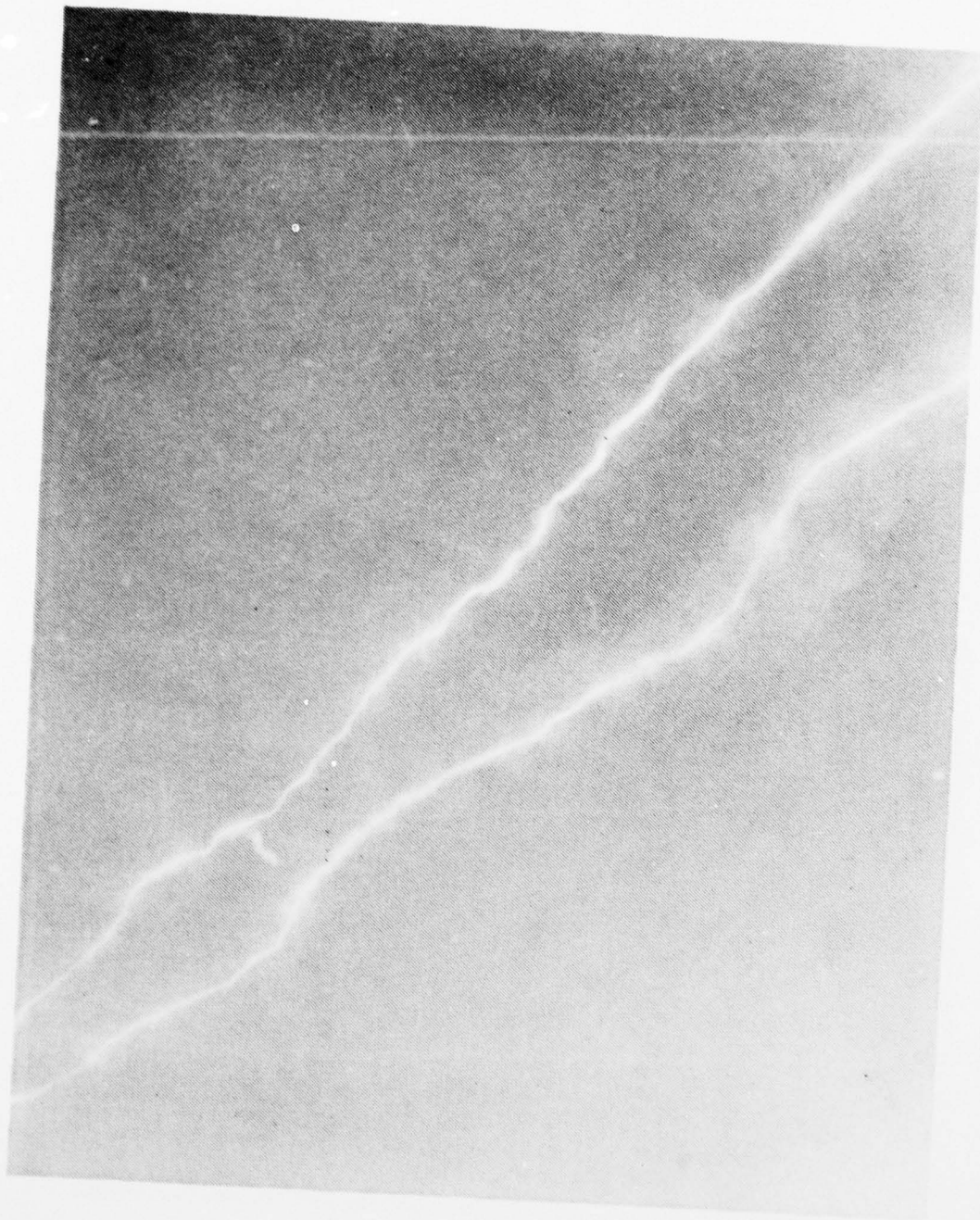

2-35



Next set of view graphs. This maneuver has intrigued me since we've done it. This is a double inverted snap roll at 6 miles behind the augmented configuration and sometime when anyone has a lot of time and can help me analyze it, I'd really appreciate it. First of all, as we enter the vortex it was over in a matter of seconds, we had a tremendous lateral acceleration and that sure makes your co-pilot very uncomfortable. But it's a tremendous side acceleration and then you'll notice a negative acceleration while the angle of attack is building to 30 degrees. So pretty soon you say: Holy smokes, what's going on. And keep remembering that the impact on the probe or victim airplane is not just roll. It's also angle of attack and also violent yaw. Think about this. Negative acceleration, positive angle of attack. It's quite a drastic maneuver and it's something that I think proved beyond a shadow of a doubt that we can produce augmentation. One characteristic of this particular maneuver is that we far exceeded the capability of our data acquisition system to pick up roll rate.

The next set of slides. I was just beginning to have fun when the fellows in the control center called it off. They said we exceeded the structural limits of the airplane or some such dribble, but we do want to say that on all of the flying that has been done even in those cases where we have exceeded structural limits, we have not hurt an airplane, and that might be of great interest to some of the structural people and it may be because of the very, very sharp impact and short time duration.

Now, here's our favorite subject and the one which will form the basis of what we honestly believe is a very easy modification to the existing fleet of jet transport airplanes, not just the heavies. The latest configuration which we have tested is the two outboard spoilers on both sides, 1, 2, 11 and 12 as you've just seen, and the characteristics are that you have a more diffused wake. The wake persists at approximately 4.5 miles. The T-37 has been controllable to 1.7 miles. Bank angles there for very long exposures did not exceed 45 degrees bank. Again, I want to stress that. Where we stay in here, we're deliberately doing that and

AD-A077 897

TRANSPORTATION SYSTEMS CENTER CAMBRIDGE MA
FAA/NASA PROCEEDINGS WORKSHOP ON WAKE VORTEX ALLEVIATION AND AV--ETC(U)
OCT 79 W D WOOD

F/G 1/2

UNCLASSIFIED

TSC-FAA-79-77

FAA-RD-79-105

NL

2 OF 4
AD
A077897

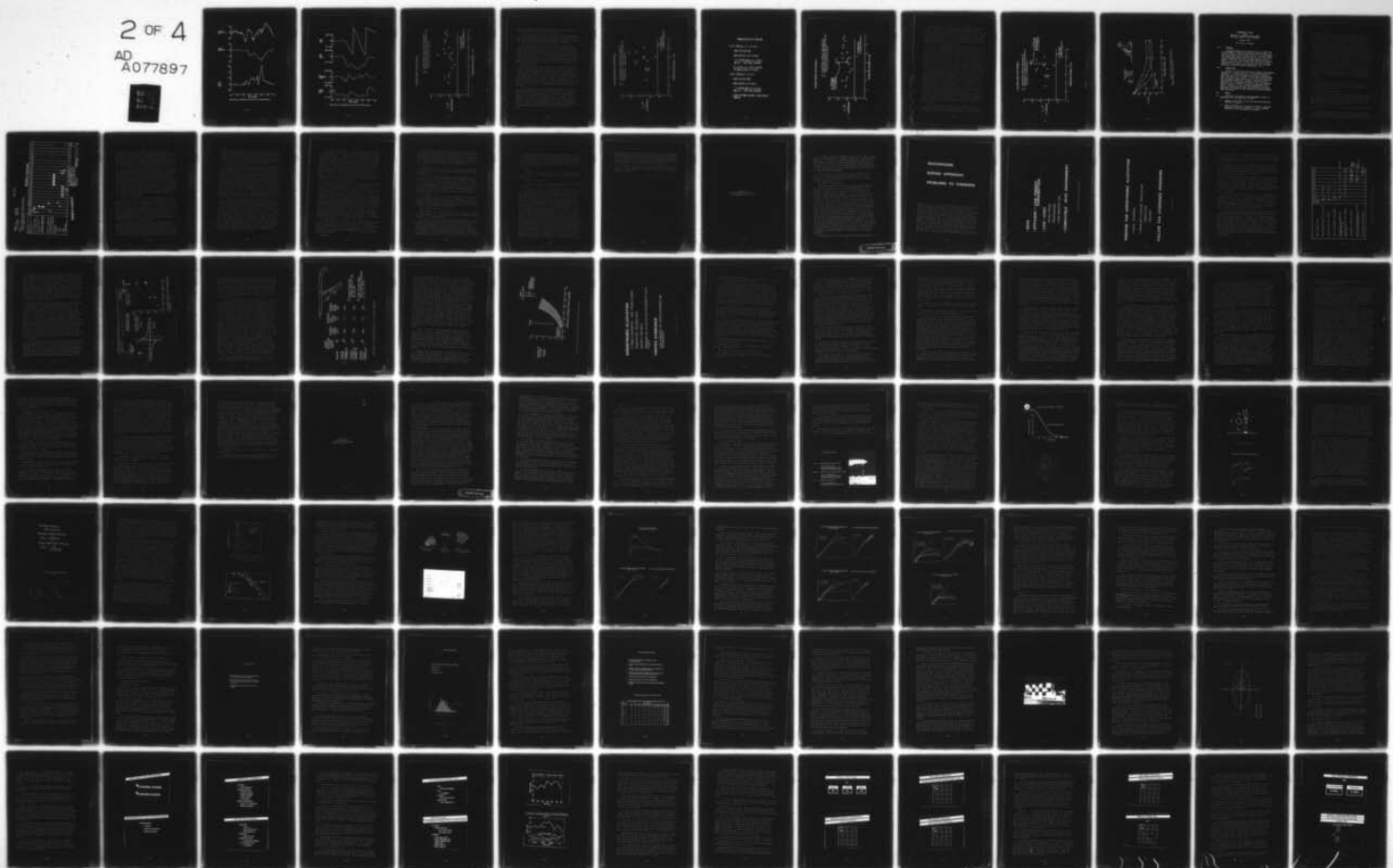

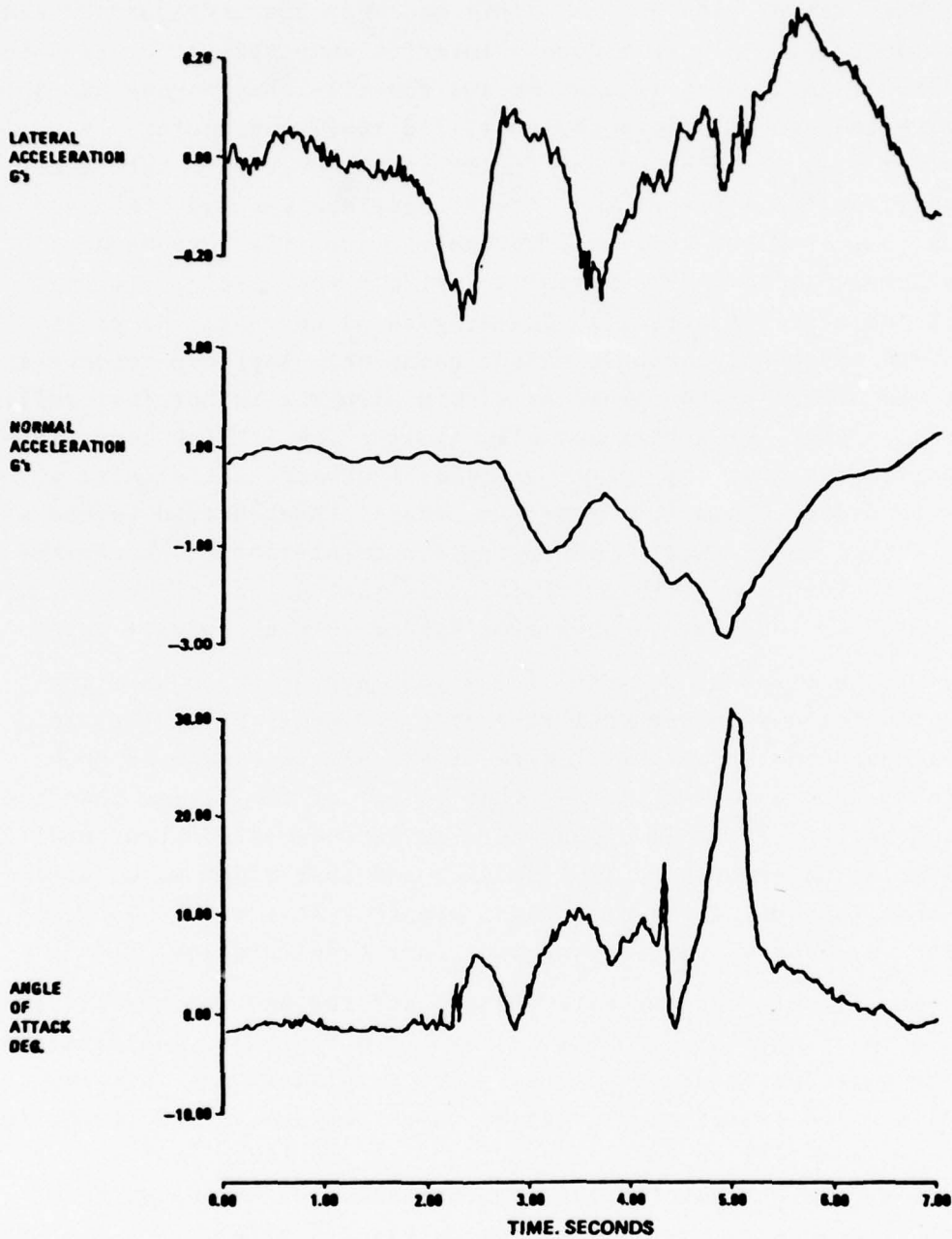

TIME HISTORY OF A T-37B ENCOUNTER OF A B-747 WAKE. (B-747 5/30 Flap Configuration).

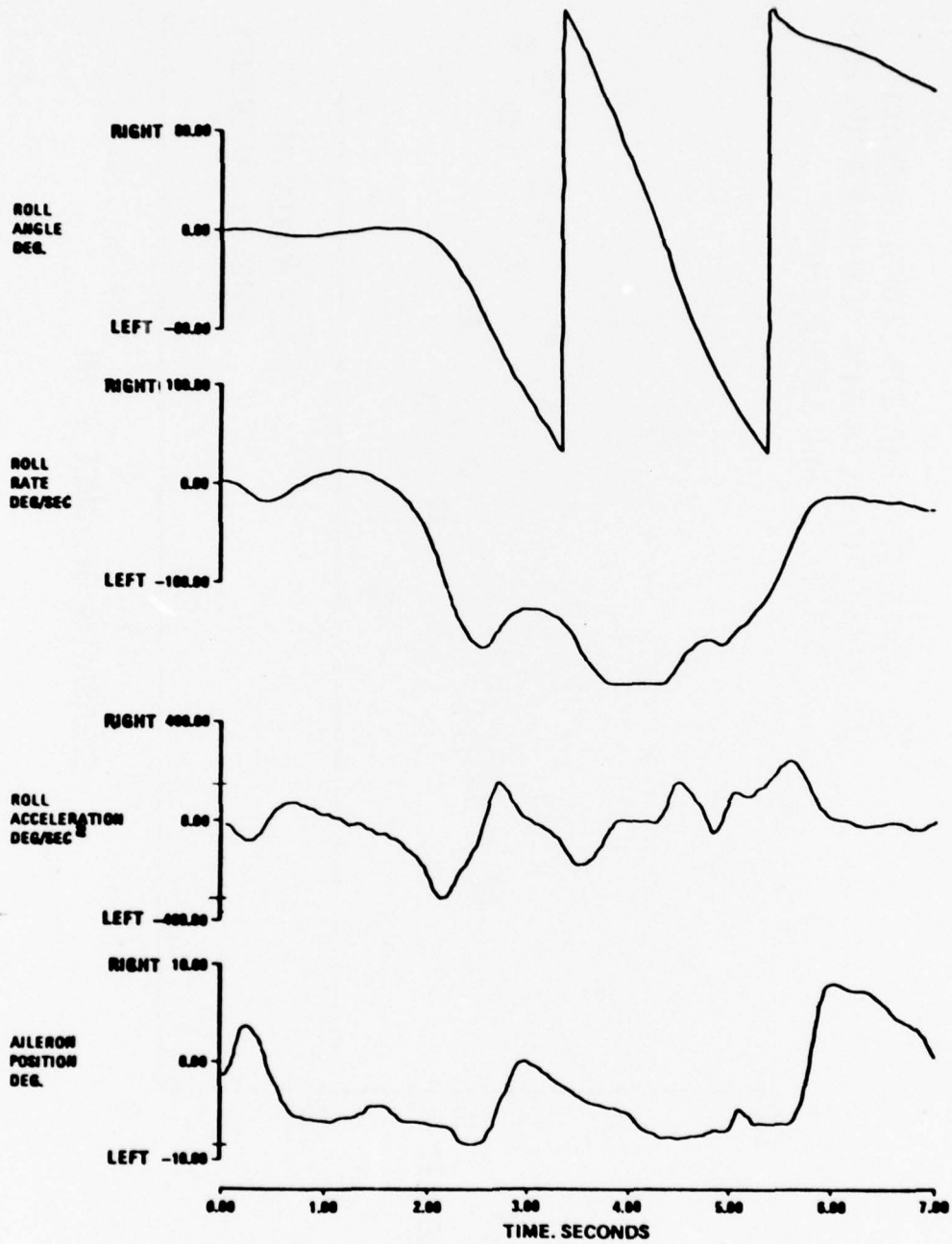

TIME HISTORY OF A T-37B ENCOUNTER OF A B-747 WAKE. (B-747 5/30 Flap Configuration).

747 WAKE VORTEX UPSET POTENTIAL

- CONVENTIONAL LANDING CONFIGURATION
- CONVENTIONAL LANDING CONFIGURATION PLUS SPOILERS 1 AND 2 DEFLECTED 41°

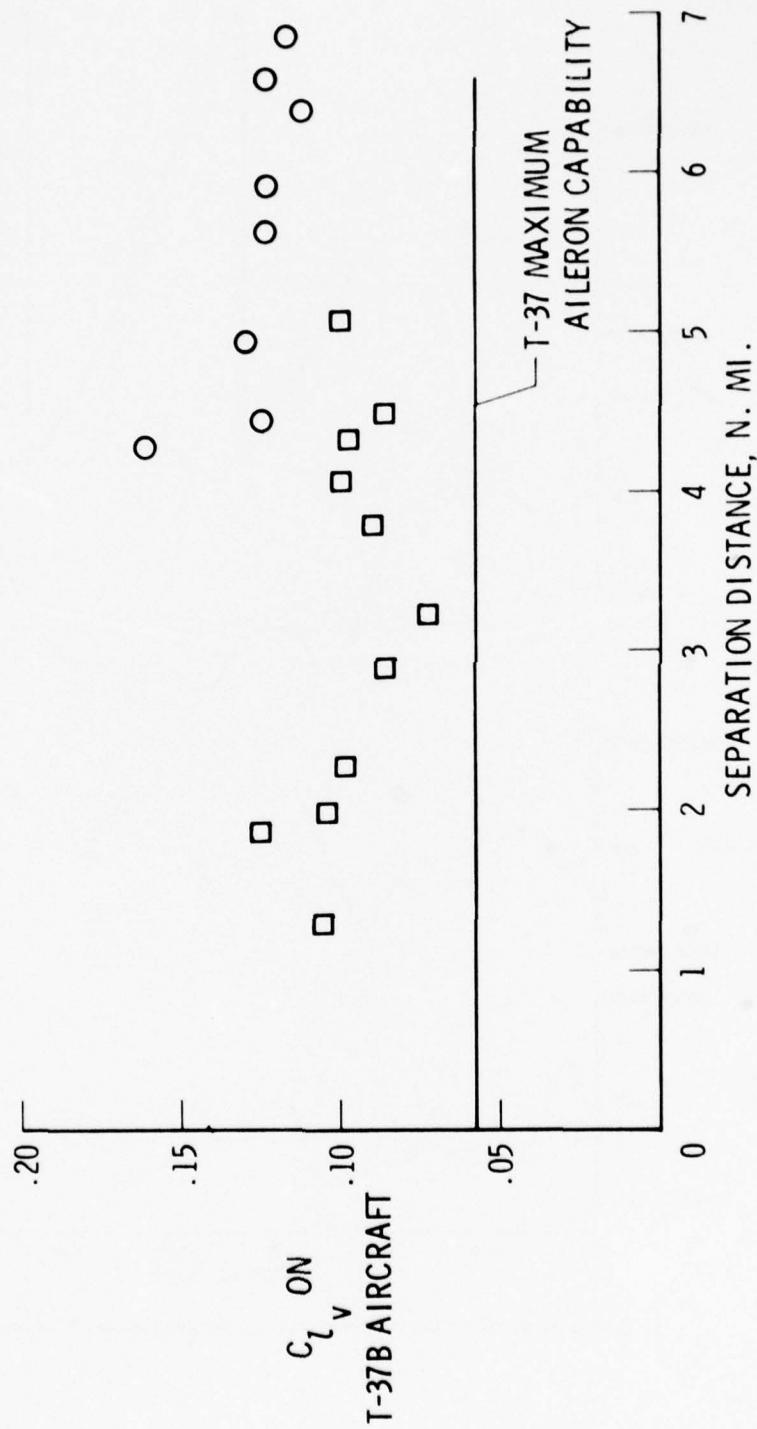

wrestling with the vortex and that should not be compared with the brief exposures in the unattenuated vortex.

We also tested the DC-7 at 3 miles and we have the conclusion (and a very brief test in the time allotted us using the FAA DC-9) that the characteristics in the attenuated configuration were about the same at 3 miles compared to unattenuated at 5 miles.

The 1011, the very first -- one of the very first flights we had, we used spoilers 3, 4 and 5 at a rather large deflection, rather large noise level and drag, but it showed that we also had a more diffused wake. The wake persisted to 4 miles and we could also work our way into 1.7 or 1.8 miles again and maintain bank angles of 45 degrees or less for very long exposures. Again the tests are called off because the airplane is instrumented and somebody said you're exceeding structural limits and you have to call it off at that point.

Now, the loads on a probe airplane are significantly reduced in the attenuated configuration and maybe we've been kidding ourselves in talking about such parameters such as rolling moment coefficient bank angles and also roll acceleration compared to the roll control power of the airplane. Again you see that in the 1, 2, 11 and 12 deflected to 41 degrees we have an airplane that is relatively controllable to about 5 miles. You can't find very much beyond 5 miles whereas in a normal configuration you're really way up there.

We are looking for correlation between flight test and wind tunnel work. This line crudely drawn in on the data you have seen before, was the wind tunnel predicted increment of attenuation measured by its reduced rolling moment on the airplane. This is what Del Croom predicted. We applied that to the basic airplane and you see that we're getting that kind of level of attenuation. So we feel that the work being done in wind tunnels and water tanks is paralleling and correlating very closely with flight test work.

L-1011 WAKE VORTEX UPSET POTENTIAL

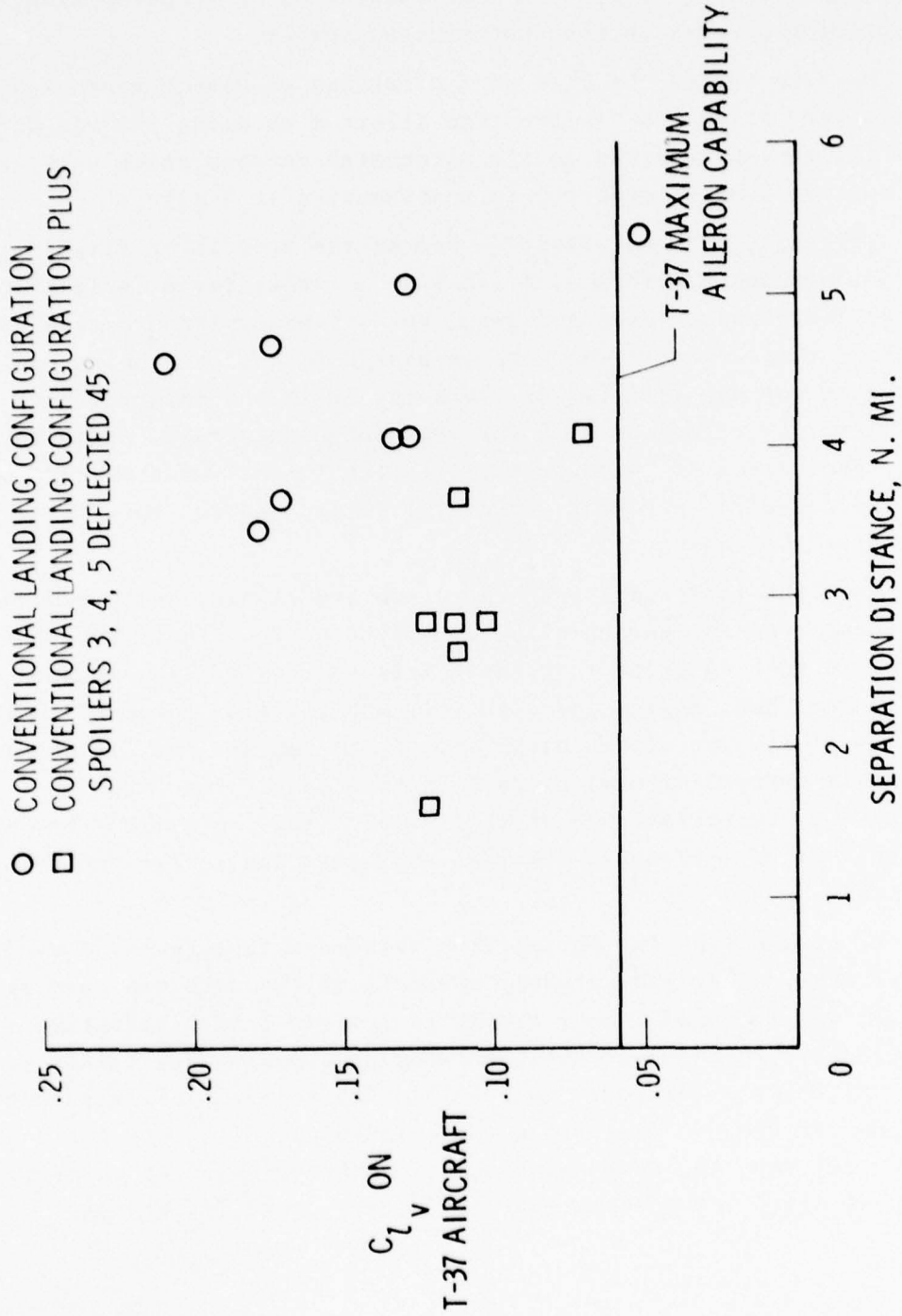

CHARACTERISTICS OF SPOILERS

B-747 (SPOILERS 1, 2, 11 & 12)

MORE DIFFUSED WAKE

WAKE PERSISTS TO 4.5 MILES

T-37 CONTROLLABLE TO 1.7 MILES
($\phi < 45$ - VERY LONG EXPOSURE)

DC-9 UPSETS AT 3 MILES SIMILAR
TO UNALLEVIATED AT 5 MILES

L-1011 (SPOILERS 3, 4, & 5)

MORE DIFFUSED WAKE

WAKE PERSISTS TO 4 MILES

T-37 CONTROLLABLE TO 1.8 MILE
($\phi < 45$ - VERY LONG EXPOSURE)

LOADS ON PROBE AIRCRAFT SIGNIFICANTLY
REDUCED

747 WAKE VORTEX UPSET POTENTIAL

- CONVENTIONAL LANDING CONFIGURATION
- CONVENTIONAL LANDING CONFIGURATION PLUS SPOILERS 1 AND 2 DEFLECTED 41°

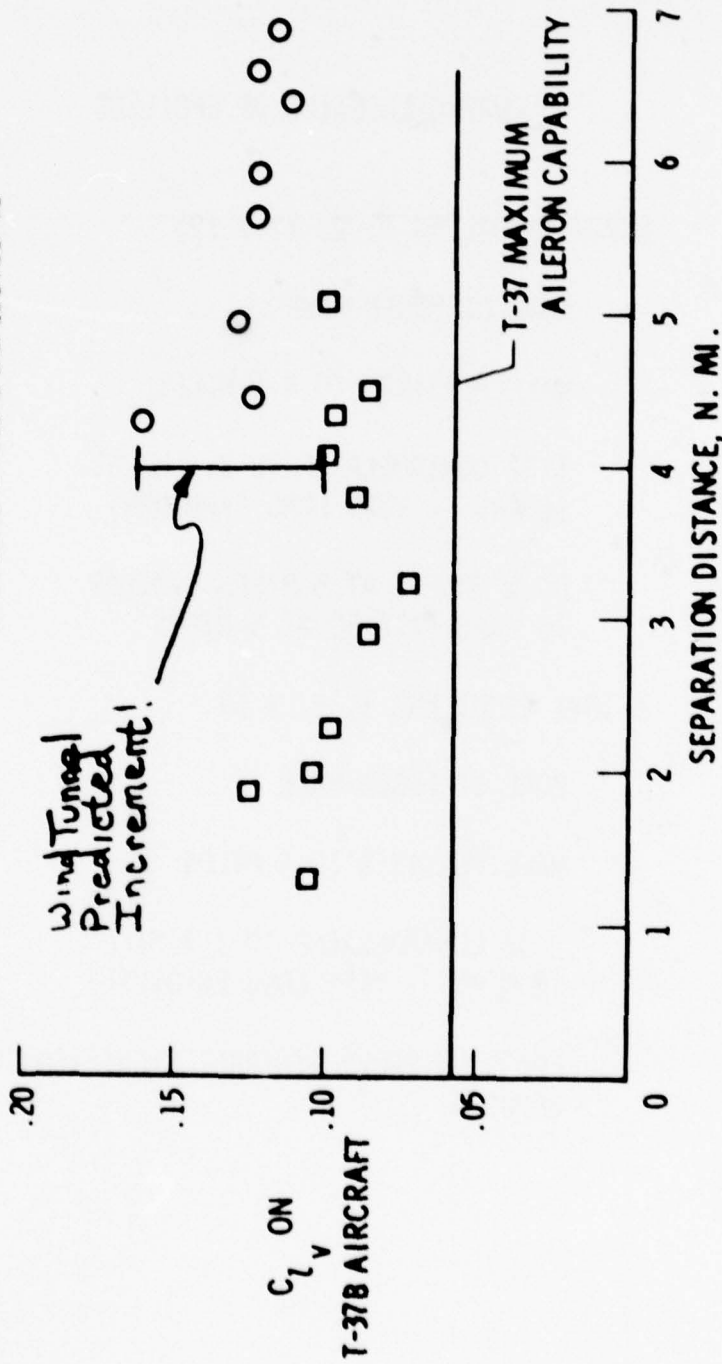

That's the 1011. Again we're talking about the normal configuration and you see the similarity with previous data. Out here, for example, at 4.5 miles behind a 1011 in a 3-degree descent, you just enter the vortex and you get a roll of 540 degrees. Again, a one and a half snap roll. You work your way in the attenuated configuration all the way to 1.8 miles and there is absolutely no question in your mind that you have achieved a degree of controllability that you could not have before.

Now, this is our hope for the very near future. I would have given anything in the world to have flown this configuration for this conference. But as you know, the space shuttle 747 is no longer available to us and we are working with Boeing to use their No. 1 747 to continue this type of work. The squares are the spoiler segments deflected as in our early test 1, 2, 11 and 12. These are 2 and 4. These are 2, 3 and 4. This is Del Croom's latest configuration and lo and behold, whereas in flight we were required to have something like 38 to 41 degrees of deflection on these, up in this area, he has found a configuration that will give us less attenuation well within the roll of control power of the T-37 with three spoiler segments at 15 degrees. Now, we'll talk a little more about that this afternoon. But that means if we see that kind of increased attenuation and flight test, we've got it made. This kind of deflection is not too different from the Lockheed 1011 DCL. In terms of noise, we're talking about something like 9/10ths of a dB compared to 2 or 3 dB up here. In terms of cost we will again discuss that this afternoon. This is about \$2 an approach more for 2.5 minute ILS than the attenuated airplane, so I think we'll have some valuable data for you, at least the very best estimate we could get from the manufacturers on noise levels and on economics on this particular configuration. Anyway, it represents a white hope, and we only hope that Del doesn't get too tired before he applies the same magic to the DC-10 and 1011.

This is a statement of work that is now being worked with Boeing to use their No. 1 747 to continue the work that was being done with the space shuttle-carrying airplane. They consist of

L-1011 WAKE VORTEX UPSET POTENTIAL

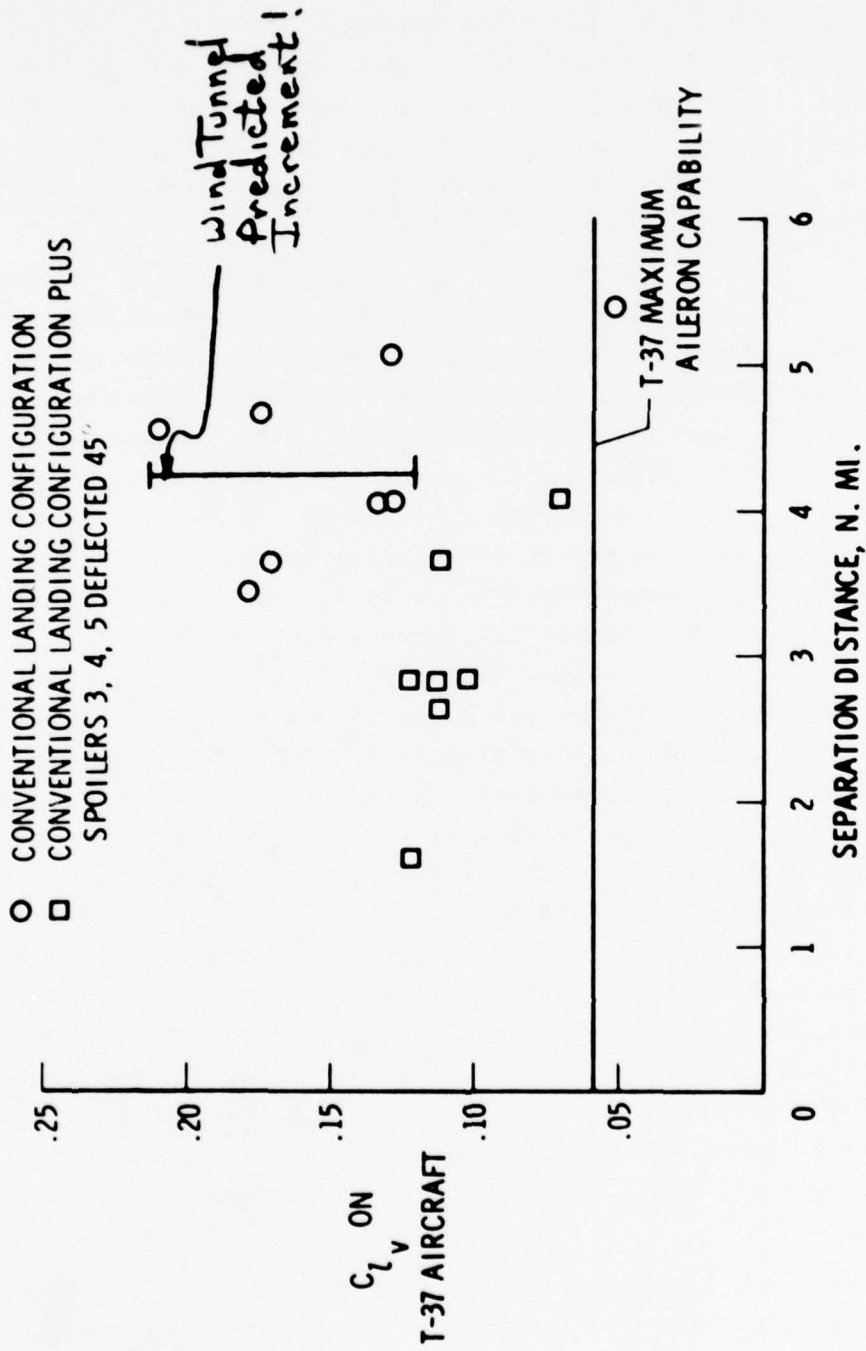

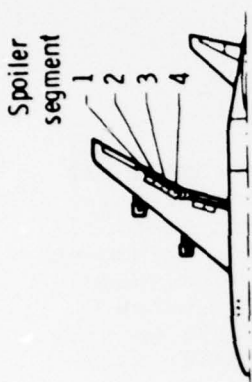

Spoiler segments
deflected

- 1 and 2
- ◇ 2 and 4
- △ 2, 3, and 4

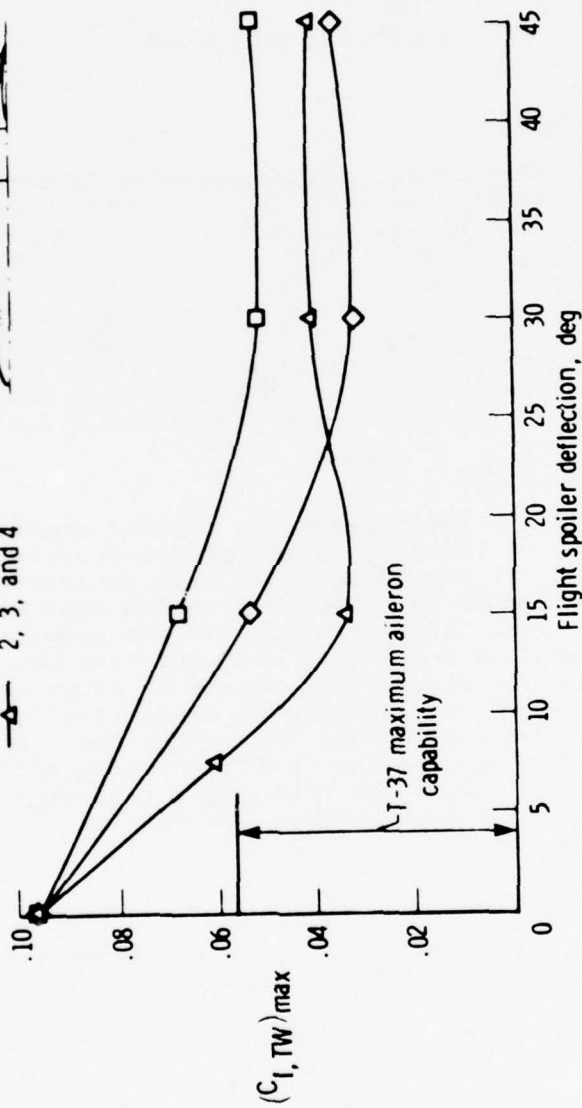

Variation of trailing-wing rolling-moment coefficient with spoiler deflection. B-747 model, gear down; $C_{l, trim}$ 1.2; LearJet-sized model 7.8 spans downstream

STATEMENT OF WORK
FOR
BOEING 747 AIRCRAFT FLIGHT TIME
FOR WAKE VORTEX FLIGHT RESEARCH

October 1978

PR 77-623 PR 78-446

1.0. General

The NASA Dryden Flight Research Center (DFRC) has a requirement to measure the wake vortex characteristics of a Boeing 747 aircraft flying with non-standard configurations of spoiler deflections. The requirement for these measurements results from recent wind-tunnel tests conducted at the NASA Langley Research Center (LaRC). The wind-tunnel tests have defined two spoiler configurations for the 747 aircraft that provide significantly more wake vortex attenuation than has been observed in previous tests (Reference 7.1.0).

2.0. Objectives

Figure 1 illustrates the rolling moment coefficients induced on a trailing model for the configurations of interest. It should be noted that spoiler segments 1 and 2 deflected to 41 degrees is the best configuration that has been flight tested. If the new configurations are as good as these data predict, then the attainment of a workable attenuation scheme is close at hand. Therefore, it is desirable to obtain in-flight measurements of the roll upsets induced by these configurations. Further, if the in-flight measurements yield results as positive as these data reflect it would be desirable to attempt actual landings at reduced separation distances.

3.0. Scope

3.1. The effort required by this Statement of Work is separated into two phases as follows:

1. Flight verification of the two new configurations defined in Figure 1.
2. Actual landings of a trailing aircraft at reduced separation distances (target 3 n. miles) behind the best of the configurations tested.

two parts, the first will be a flight verification of the two new configurations we find in Figure 1 in the previous slide. If we get the attenuation that we expect, that means we're really going to have something to work with down to a landing. And the second part of it will be the actual landing of a trailing aircraft at reduced separation distances. We're targeting for 3 miles as it says here, but our real target is one-half the distance shown previously, behind the best of the configurations tested. Now, if we are not exactly happy here we're going to have to resort to a remotely piloted vehicle, an F-86, to do some of the initial landings in order to dispel the argument of what is the relative strength of the vortex in ground effect compared to free air and so on.

Very briefly, this shows a time schedule for when we hope to achieve this. This is a time period for No. 1 747 where they're going to install the active control system. We have to work in here, hopefully, within January, just six or eight weeks from now, we hope to get a crack at the very first 2, 3 and 15 degrees and then hopefully follow through with actual landings behind that airplane.

That's it.

Now are there any questions immediately following that. I think time is running short and we had better save questions for afterwards and return it to Joe.

MR. STICKLE: Thank you, Joe.

I told you that this would be the interesting part. We still have Al Gessow to talk about the future plans in the program and what our requirements are. Al is the Chief of the Aerodynamics and Physics Branch in our Office of Aeronautics and Space Technology. So, Al, I'll turn it over to you.

MR. GESSOW: I'll try not to keep you too long from your lunch hour.

You've seen a couple of examples where perhaps there's been a slight overlap in material that we NASA authors have presented. I therefore listened very carefully to what Jim Kramer had to say

this morning, perhaps a little bit more so than most of you, because, if his views of NASA's role in the wake vortex picture differed in any substantial way from what I was prepared to say, then I had a problem on my hands. Fortunately for me and for my perception of our role in the wake vortex picture, Jim and I are in substantial agreement. That means my remarks on NASA's future role really underscores what you've heard earlier this morning.

Our future plans could be stated very simply. As of now, we have no plans for a large scale follow-on program of the magnitude which produced the results that you've heard this morning from Stickle, Dunham, Tymczyszyn and Barber. We do intend, however, to carry on a low-keyed R&D effort which would further our understanding and our ability to predict the characteristics and mutual interference behavior of multivortex wake systems. This low-keyed R&D effort would be centered about our computational effort, which you have heard about, and would involve also some small and moderate wind tunnel studies. This information would be applicable to the design of future aircraft systems in which wake vortex alleviation is a consideration.

Now that I've given you the bottom line statement of our plans, I'd like to go back a bit and review some of the reasons why we don't have a more comprehensive long-range plan, and in the process repeat a little bit of what Stickle said. You will recall that he said that in the summer of 1972 we were asked by the FAA to make an assessemnt as to whether wake vortex alleviation by aerodynamic means was feasible. Our assessment of the situation would be a consideration in the decision the FAA would have to subsequently make as to the necessity for developing and installing wake avoidance systems at major airports.

As you know, we reported in January of 1974 that we were guardedly optimistic that aerodynamic solutions were feasible. At that time, therefore, we had essentially completed what we had set out to do and we were duly thanked for our efforts by the FAA. By then, however, we were convinced that we were hot on the trail of some definitive results, particularly with regard to a retrofit

solution. We continued our efforts and reported on our progress in some detail in a widely attended symposium on wake vortex minimization which was held in Washington in February of 1976. We also reported more recent results in the workshop that was held here in March of last year, and you've just been brought up-to-date on our latest results with the papers you've just heard.

My reason for reviewing these events is to point out that the primary impetus for continuing to work in a fairly intensive way since February 1975, that is almost five years ago, has been our own perception of the significance of the capacity and the safety problems of wake vortex effects and our belief that one or more aerodynamic solutions are feasible. Except for an expression of interest by Dr. McLucas when he was Administrator of the FAA, and an occasional pat on the head by the FAA when we briefed them on our program and our progress, it seemed to us that we were pursuing our efforts under a policy of "benign neglect". (I want to point out, by the way, in order not to alienate my friends in the FAA, that when I speak of the FAA I'm talking about the agency in an overall sense, and not individual elements and people who have been interested in advancing the wake vortex alleviation efforts.)

In essence, we were unable to persuade the FAA to take the lead in pursuing a program to explore the operational, safety and economic implications of our wake vortex alleviation methods with the potential objective of reducing the separation standards. After all, a reduction in separation standards as someone mentioned earlier, is what this game is all about. I say all this, as the expression goes, more in sorrow than in anger, for I recognize the constraints, both internal and external, under which the FAA and its various elements operate. The point is, we have reached the end of the program which we have laid out for ourselves, a program which included rather expensive proof-of-concept flight demonstrations. Thus, except for the low level, long-range ground-based program which I mentioned earlier, our current program will be concluded at the end of this fiscal year.

Now, whether or not there will be a Phase II program depends upon decisions which the FAA has to make, based on their views of the overall problem. I think that this workshop could be a great help in this regard, particularly if a key phrase could be added to Conference Objective No. 4, (I believe we had four Conference Objectives given in the program that we received). Objective 4, as it's given in the agenda, is to "gain advice from the using community as to the emphasis and priority of the program and to solicit further ideas for solving the wake vortex problems." I would like to add the phrase "and for implementing the solutions." In other words, I just don't think that it's too early to think about what must be done to implement some of the solutions that appear to be feasible at this time.

I'd like to close these remarks by stating that we in NASA are prepared to cooperate with and help the FAA and the industry in carrying out programs for which we have special facilities or expertise. In such cases, however, because of the demands for our in-house manpower from a variety of other sources -- and Jim emphasized that this morning -- we would have to be convinced that the request to help is something that is needed and reasonable for us to do. I am not prepared to talk in detail about what we think should be follow-on for the implementation, but I might mention as an example that we could help determine criteria for acceptable upsets and what design changes are needed to meet these criteria. Also, some of the work that we've done in providing a data base for establishing acceptable upset criteria in normal operations during turbulent air might be useful in this regard. Or, further down the road we could provide flight test support for determining certification procedures of vortex alleviation devices.

So I'll conclude by saying that I hope that this workshop will provide a forum for a review of what has been done on the wake vortex turbulence problem but will help focus on a rational specific program by which some of the current proposed solutions can be tested and if successful, can be implemented to provide decreased separation distances.

Thank you.

MR. STICKLE: I see that our time is just about up, in fact, it's exceeded for our lunch. What I would like you to do since we've got half a day tomorrow to work this out, is to save your questions until tomorrow, unless you've got an urgent question and you may not be here tomorrow. Be sure however to bring them and be prepared to discuss these at the workshop session.

Jerry?

MR. CHAVKIN: Jerry Chavkin, FAA. I have one question that has been left very unclear in my mind and I think everybody needs the answer to it.

Joe Stickle, you saw a schedule up there and there was a 747 flight in 1979 -- you intimated that this was going to be done. Are the resources available for that program and will it be done, or is that something we're just talking about? I'm not sure any of us understood whether that program which you had the schedule up there for is going to be done or not done. What does NASA say about that particular year-long work between now and the end of this fiscal year '79.

MR. STICKLE: Jerry, I'll answer that because we do have the money to do that program the way that Joe outlined it. We are funded to do that, we have the plans to do it, and I have all the confidence that we and Boeing can get together on a price to allow us to do it within the funds that we have.

MR. CHAVKIN: That's this fiscal year?

MR. STICKLE: Yes. That's this fiscal year's money. And what Al is talking about is after this fiscal year we drop back in the funding to a very low R&D effort.

MR. ACHITOFF: I don't plan to be here tomorrow and I suspect that there are probably some others who won't be here either. I find that the comments that Mr. Gessow made are really rather alarming and I would hate to leave without hearing some kind of a response from the FAA or anyone else, who might be involved in these programs, to the points that were raised by him. I think this group ought to hear from the FAA and others as to why this situation

of "benign neglect" is being permitted to continue if in fact there is agreement from the FAA and others that the statements made by Mr. Gessow are in fact accurate in their view. So I would suggest, I would hope, that by the time we come back from lunch, someone ought to be able to or should make a statement or comment on the comments of Mr. Gessow.

Thank you.

MR. STICKLE: Thank you. I won't try to answer that for the FAA right now. I'll just ask Bob. Do you want to comment on that after lunch?

MR. WEDAN: After lunch.

MR. STICKLE: Okay. I see there's probably some other people who are going to leave and won't be here tomorrow.

MR. PORITZKY: Yes. I'm Sig Poritzky. I think the point, if I understood it correctly, the point that Al made was I hope, at least, misunderstood. FAA has very regularly at various levels made NASA aware of the importance we attach to the wake vortex alleviation problem. Most recently at the past two NASA/FAA management coordinating committee meetings so that I think there is very little question about where FAA stands on the need for the continuation of this work. I think the question that is perhaps important to this workshop is whether the community, all of us, can identify additional work that needs to be done. I think it's most particularly important because the need for alleviation and the value of alleviation is obvious. I think it is made more obvious from the briefing we heard this morning, which underlines over and over again that the process of detection and avoidance can always take you only part way. Now, there was no major discussion this morning about the safety impact and route operational impact of wake vortices which is also an impact, also only reducible by alleviation techniques. So that at least in my mind, and I think in the minds of all the FAA people who are here, there is just no question that wake vortex alleviation is a subject that must be attacked. The question, I think, and the important one, is whether

we can identify collectively additional efforts and perhaps equally important whether the work that has been done by NASA, which in my view is excellent work, is enough for the airplane people and the carriers now to say, yes, we understand the method of attack, we'll take it from here. I think that's really the question.

MR. STICKLE: Thank you, Sig. I think that wraps it up pretty good. I'll talk to Bob and see whether he wants to add anything after the lunch break.

SESSION III
PROGRAMS AND ACTIVITIES OF
THE AIRFRAME MANUFACTURERS

MR. HODGE: I'd like to introduce Session 3 now, which has the purpose of documenting the programs and activities of the airframe manufacturers. Are there any other spokesmen who would like to be heard during this time? We have representatives from Boeing and Lockheed. If there are any other representatives who would like to be heard during this time, please come forward and we'll give you a chance to make your statement.

If there are not, I'd like to proceed to introduce Jerry Lundry from the Boeing Commercial Airplane Company. Jerry is Supervisor of Low Speed Aerodynamics Research and he'll make a statement on behalf of Boeing.

MR. LUNDRY: Thank you, Ken.

This morning I would like to give you some background material from the viewpoint of an air frame manufacturer. This is primarily a review of some of the factors that make good competitive airplanes for our customers. I'd like then to show you something on the Boeing approach to the wake vortex problem and finally consider some of the problems that we still face. The view on the right here shows a list of desirable airplane characteristics. First and foremost of course is they have to be safe. Increasingly important is the second factor there, they also need to be efficient, particularly with respect to energy consumption. That's become a far more important question in the last five years. The major importance to our customer is the cost of the aircraft, both the initial price that they paid for the airplane and the cost of maintaining and operating it. And another factor here is that airplanes should be designed for long service life, so that the initial price can be spread. And finally, something that's also becoming increasingly important with our understanding of environmental problems, the airplanes that we produce must be compatible with the environment, both from the noise emission standpoint and from the viewpoint of emissions in the form of pollutants.

This illustrates I think a summary of the Boeing approach to

BACKGROUND

BOEING APPROACH

PROBLEMS TO CONSIDER

the wake vortex area. We are preparing for an aerodynamic alleviation. Aerodynamics of course is a prime concern to the air frame manufacturer and we're doing this in two ways, we're following NASA's program very closely. They've been very active at Ames and at Dryden and Langley, and we've kept up with that program as it has developed. We've also done some work to develop in-house technology. This is a small scope project relative to NASA's. We've concentrated on predictive technology. We'd like to be able to provide the technology to an airplane designer so that he can make estimates on the wake vortex characteristics of new aircraft while we're in preliminary design. And this is a special sort of requirement that we're implementing in the form of

- **SAFE**
- **EFFICIENT - LOW ENERGY CONSUMPTION**
- **LOW - COST**
 - INITIAL PRICE
 - MAINTENANCE
 - LONG SERVICE LIFE
- **COMPATIBLE WITH ENVIRONMENT**

PREPARE FOR AERODYNAMIC ALLEVIATION

- NASA PROGRAM
- DEVELOP IN-HOUSE TECHNOLOGY
PREDICTIVE
TESTING

FOLLOW FAA AVOIDANCE PROGRAMS

BOEING APPROACH

computer software, but for the airplane designer to use it, it has to be relatively simple. It has to be readily usable and the costs of operation have to be small. So it is specialized in that sense of approximations.

The goal of that effort is to be able to track wake vortex characteristics of new configurations as they develop in much the same way as we track characteristics now, such as airplane noise. It is not a major effort, the wake vortex characteristic would be another configuration parameter to be checked.

We're also in the process of developing some in-house testing capability. With respect to the FAA avoidance programs, we don't see that having the same impact, the same level of impact on the manufacturer. We are following it very closely. We want to remain alert to the possibility that the FAA will have some impact in the future on their airplane designs. Presumably that would occur in equipment.

I'd like to discuss next a little bit of the chronology of the Boeing vortex effort. Our wake vortex work extends back over ten years. The early work concentrated on comparative flight tests between the 747 and the Boeing 707. We also had some basic stability work done by Steve Crow and also some experiemnts related to that. That sort of culminated in Boeing's co-sponsorship of a wake vortex symposium in Seattle in 1970.

The next line down, the broken line, indicates intermittent support of both FAA and NASA activities that continue to the present. We've placed ourselves more or less on demand to those agencies and have attempted to cooperate with them. Starting in about 1975 we then did begin our development of predictive efforts and that continues to the present. In March of 1977 you saw two papers presented here in this room on that subject. The next to the last item on this view film on the right indicates the work we did under contract to NASA to evaluate the practical impact of four alleviation concepts, and that work too was reported here 20 months ago.

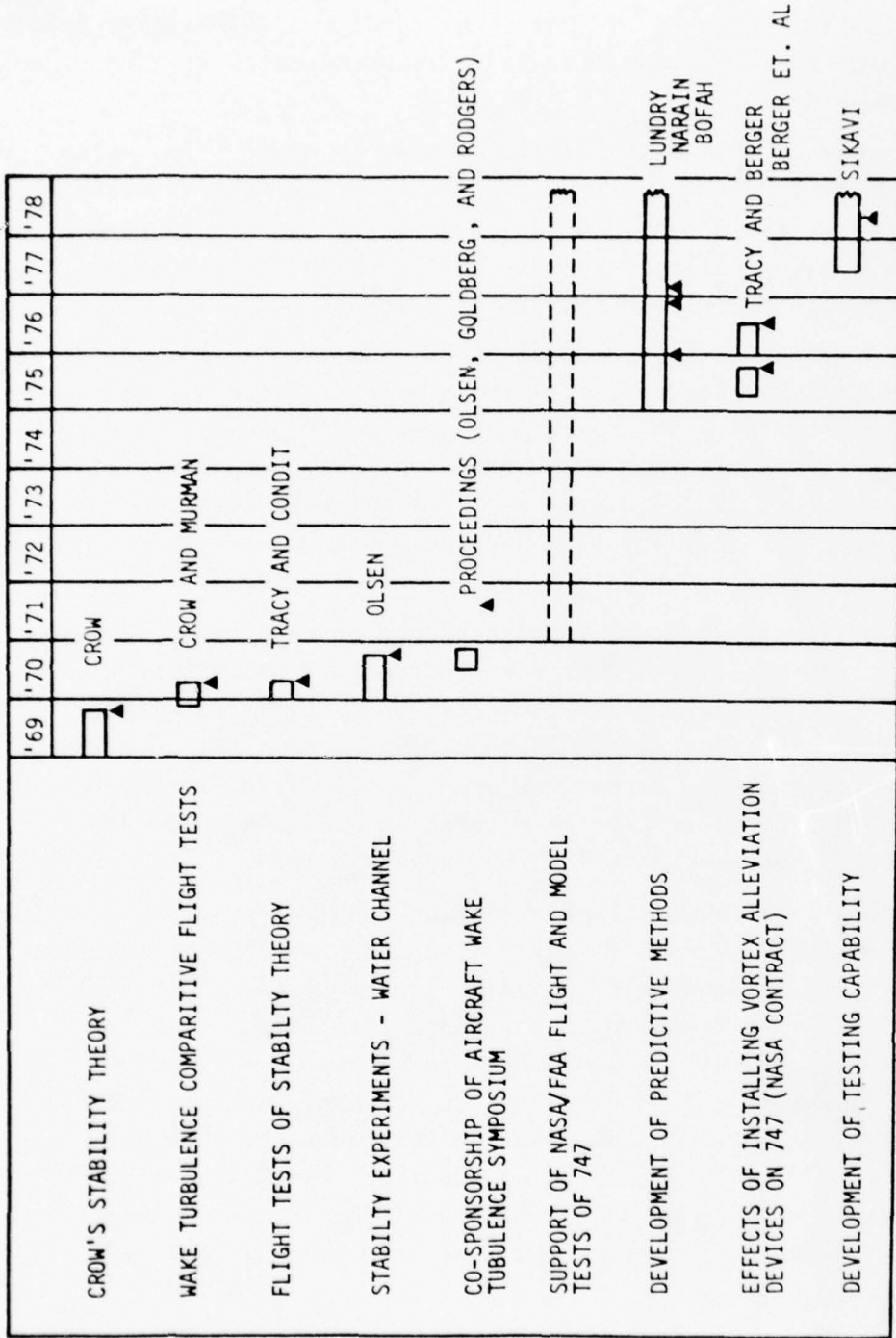

CHRONOLOGY OF BOEING WAKE VORTEX EFFORTS

Finally, the last part of this chart shows that we are working to develop in-house experimental capability. I'd like to just show you briefly a couple of results in the next two view foils of our effort. The first one pretty much summarizes the current state of the art for predictive technology. You see here a test theory comparison. We made theoretical calculations of the tangential velocity component shown on the left side of this figure, the tangential velocity components given on the ordinate as a function of the distance from the center of the vortex. They use basically a Betz approach to the theoretical model and as you can see the circles representing the data and the line representing the theory are in good agreement.

On the right side we have a figure which shows the maximum induced rolling moment both predicted and measured for a small following model, as a function of the lift coefficient on the wake generating airplane. The upper part of the figure shows that there were two following models, a small rectangular platform and a small swept wing. The open symbols in both cases indicates test data and the solid symbols indicate the predicted levels. So this gave us a good feeling that the work we'd done to this point was giving reasonable predictions of the test data. This work, of course, is restricted. We've chosen the convenient place for comparison, namely that the vortices are effectively rolled up at this point so there's not the problem of taking measurements in the roll-up region. But we are also at such a position that the significant decay has not occurred. So neither of those two parameters are well modeled in the work that was just shown here.

Also, this shows a case for a single trailing vortex on either side of the plane and we need to get more work done to be able to model the multiple vortex case. We've already made mention of the effect of using spoilers on the 747 airplane, and I'm going to repeat some results here that were presented in March of 1977 and also show two results for two of the new spoiler configurations that have been identified by Del Croom at Langley. The

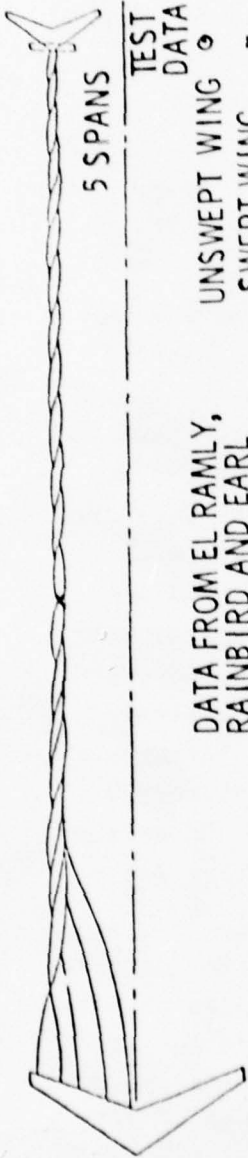

TEST DATA
 ○ UNSWEPT WING
 □ SWEPT WING

THEORY
 ● UNSWEPT WING
 ■ SWEPT WING

DATA FROM EL RAMLY,
 RAINBIRD AND EARL

○ TEST DATA
 — THEORY

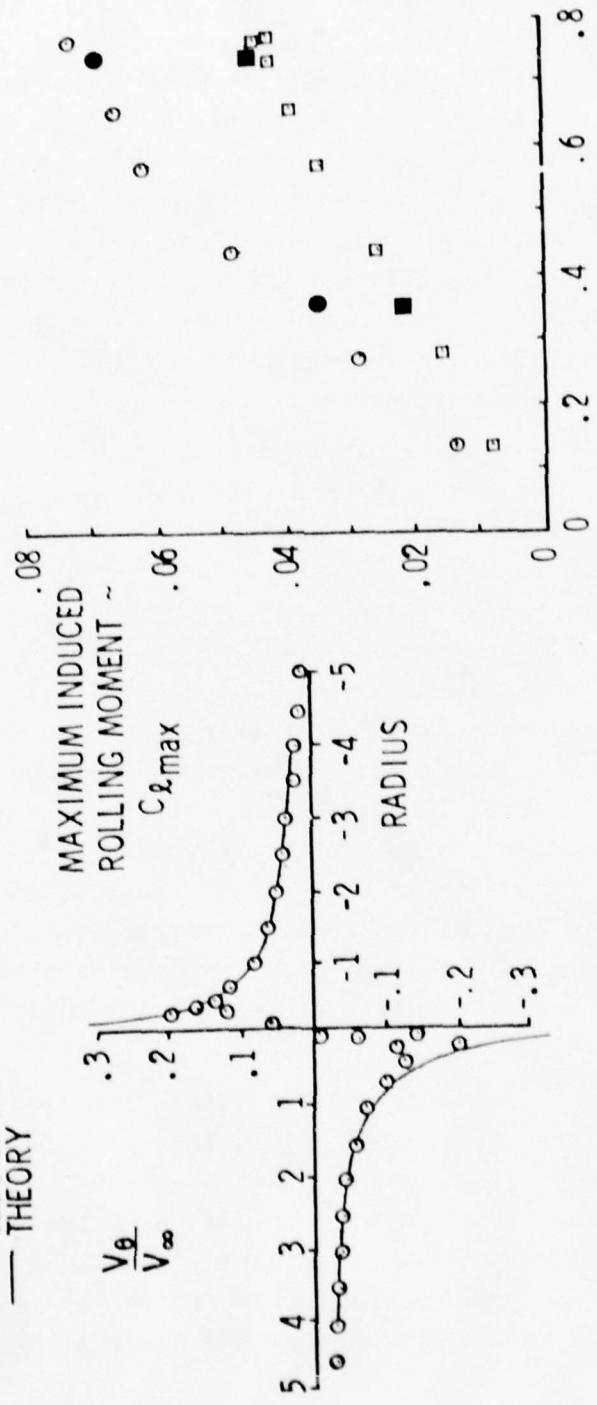

LIFT COEFFICIENT OF WAKE-GENERATING AIRPLANE $\sim \bar{C}_L$

COMPARISON OF THEORY WITH TEST DATA

three columns on the right here are airplane characteristics in approach configuration, approach speed, touchdown body attitude and approach noise. And for all three of these, of course, the lower the better. Touchdown body attitude is important but needs a little explanation. The greater the touchdown body attitude the larger the chance there is for tail strike in a statistical sense. Tail strike does not occur very often on landing. We just simply know that our higher body attitudes are worse than lower ones.

I've shown figures here for four configurations. At the top level is the baseline 747 and the first column next to that is the estimated Learjet separation distance based on the work that was cited by NASA in the reference given on Flight 1. They indicated a separation distance of about 9 miles for that particular criteria used there. The early spoiler configuration, Spoilers 1 and 2 and 11 and 12 (on the other side in Boeing nomenclature) extended 45 degrees, cut that requirement to three miles. However, it increased approach speed by 7 knots, assuming that the spoilers remained extended, yet increased the body touchdown attitude about a degree and a half and increased approach noise by 2 dB. The two new configurations are in the next two columns; Spoilers 2, 3 and 4 deflected only 15 degrees rather than 45 and Spoilers 2 and 4 extended 30 degrees. Now I put down there for the separation distance less than 3 miles. Neither of those have flight tested. They are scheduled to be flight tested. We put down less than 3 miles simply on the basis that in the wind tunnel those configurations had lower induced rolling moments than the Spoiler 1 and 2 configuration. Both of those configurations are improved relative to the Spoiler 1 and 2 configuration. You can see that the approach speed increases are smaller, the body attitude is more nose down for Spoilers 1 and 2, and the noise levels are lower as well. The spoiler configuration 2, 3 and 4, I think, probably looks best on this comparison.

I'd like to emphasize that this doesn't come for free, particularly in the area of noise and the next view foil relates

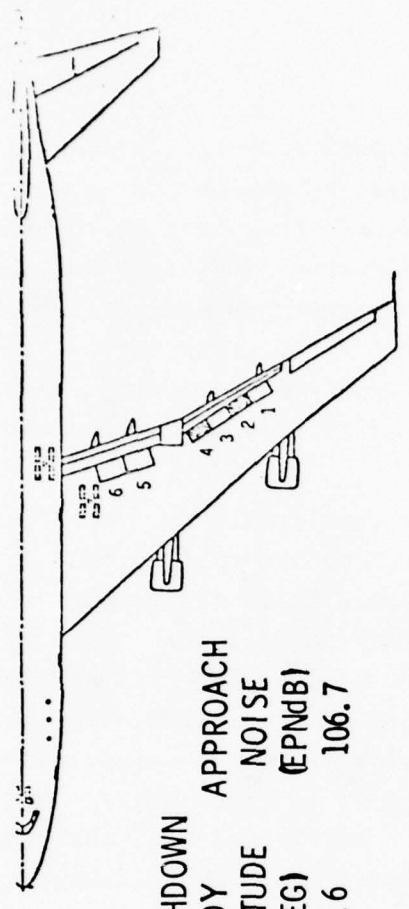

LEARJET SEPARATION DISTANCE (MILES)	APPROACH SPEED (KNOTS)	TOUCHDOWN		APPROACH NOISE (EPNdB)	PILOT'S QUALITATIVE ESTIMATE (NASA SP - 409, pgs. 388, 401)
		BODY ATTITUDE (DEG)	ATTITUDE (DEG)		
BASELINE	141.5	5.6	5.6	106.7	① PILOT'S QUALITATIVE ESTIMATE (NASA SP - 409, pgs. 388, 401) ② BASED ON WIND TUNNEL DATA, RELATIVE TO SPOILERS 1, 2, 11, 12 AT 45°
SPOILERS 1, 2, 11, 12 EXTENDED 45°	148.5	7.2	7.2	108.7	
SPOILERS 2, 3, 4, 9, 10, 11 EXTENDED 15°	144.5	6.6	6.6	107.6	
SPOILERS 2, 4, 9, 11 EXTENDED 30°	145.0	7.0	7.0	108.4	

to the noise penalties that you see here. This is an overall study that was done to show the effect of decreasing approach noise on the 747 and how it impacts fuel economy. Sound treatment doesn't come for free and we do pay a penalty for it at cruise. What I've shown here is a broad band. There have been numerous studies of sound suppression for the 747 involving different engines and different configurations. I showed the band so that it wouldn't get bogged down in discussions of which one has to be more important than another. But the key thing here is to meet FAR Part 36, we are now paying something on the order of one percent fuel penalty in cruise and we pay that all the time, of course. If you remember, from the previous view foil we showed noise penalties in the order of 1 to 2 dB in approach. I wanted to show this view foil to indicate to you that if we choose then to recover those noise penalties by treating them as cells and the treatment, of course, would be full-time, we couldn't take it out during cruise configuration, then we would be paying, if you look at the middle of that band, roughly another half a percent to one percent to recover 1 to 2 dB on approach noise. This, of course, is counter to our current trends. We're trying to at least maintain or reduce noise levels rather than letting them to up.

Finally, I'd like to indicate some challenges to consider here, and you'll notice I changed the title from problems to challenges to reflect an up-beat attitude. In the area of aerodynamic alleviation we've been following NASA's program. They've identified five concepts which is quite an accomplishment in itself. A few years ago a lot of people were saying that there was nothing that could be done about wake vortices. So NASA's program, I think, has to be considered successful from that point of view.

We need to ask the question, are there more concepts. Is there something that we overlooked? And I think we also need to understand these concepts better. We understand in terms of measurements of induced rolling moment and so forth and it would be nice to understand a little more about the physics of them.

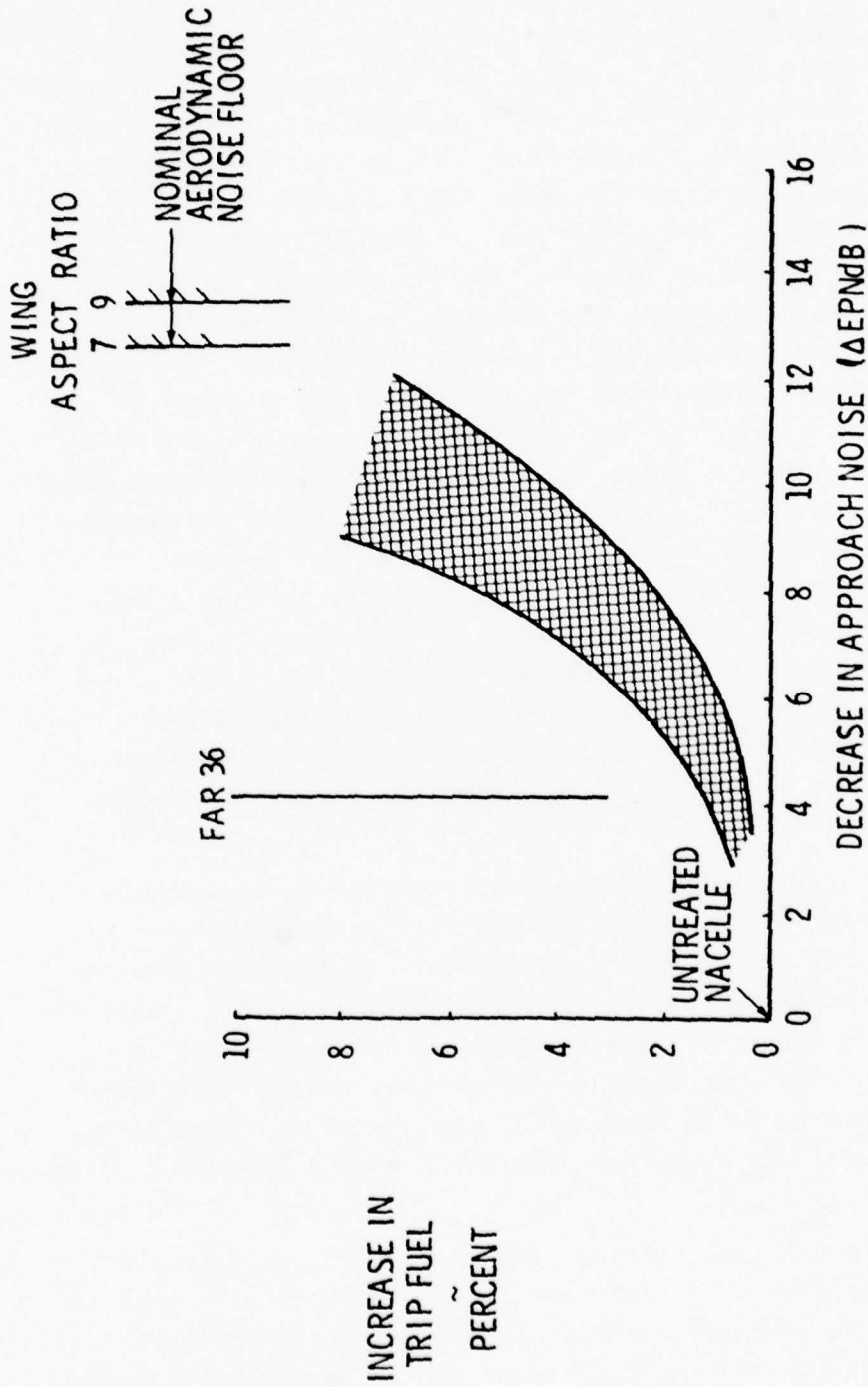

EFFECT OF APPROACH NOISE REDUCTION ON ENERGY CONSUMPTION

AERODYNAMIC ALLEVIATION

5 NASA CONCEPTS - ARE THERE MORE?

PREDICTIVE TECHNOLOGY

SAFETY CRITERIA

PHASING OF ALLEVIATION CONCEPTS INTO
FLEET

VORTEX AVOIDANCE

CAN PERIODS OF EFFECTIVENESS BE
INCREASED?

CHALLENGES TO CONSIDER

I think the analytical work that is now in progress has a good chance of answering some of these questions.

The air frame manufacturers, I believe, would like to see better predictive technology, and I've already addressed that. The sort of thing that we would like to look for, so that we include it in our airplane design studies. I notice also that someone has also mentioned safety criteria as a problem. The question of induced rolling moment as a safety parameter is open now, I think. It's been used primarily because it's both easy to measure and it's easy to calculate relative to others, such as maximum bank angle. But I do think we need to understand better the criteria for safety.

One other question that has come up is the question of phasing alleviation concepts into the fleet. What happens if we do decide to retrofit aerodynamic concepts? Will there be some difficulty in having say half the airplanes implemented with this and half not.

In the area of vortex avoidance, we feel that the FAA program has been very effective. They've identified concepts for both detecting and predicting vortices and I believe that those will be discussed this afternoon. Their program has been effective in terms of system design and prototyping and demonstration. But we also, I think, are prepared to ask this question which has already been discussed this morning. Can periods of effectiveness be increased?

That concludes my presentation from Boeing's point of view for the wake vortex program.

Ken, should I attempt to take questions now or would you like me to introduce Clive?

MR. HODGE: Why don't you see if there are any.

MR. LUNDY: Okay. Are there any quick questions, keeping in mind the fact that it's 12:30?

Yes.

MR. BLAKE: Neal Blake again. You heard Al Gessow say that as far as he's concerned that there's a need for further basic research. I wonder how you feel about it and whether you think that there is adequate technology and concepts available that would allow you to go ahead, for example, and put it on the 757, 767 series; and if not, could you say when you think it might be practical to put this sort of thing in the fleet?

MR. LUNDRY: Well, I think I would give two answers to that. The first is, I believe that NASA has demonstrated that we can reduce wake vortex turbulence for aircraft. They do have a number of workable systems and I think the second part of that is that we're probably not yet prepared to pay the price for it. This is a question, of course, which we at Boeing do not decide; ultimately our customers will decide that. And our customers have not yet come to use demanding wake vortex alleviation. Our position is that we're attempting to prepare ourselves for aerodynamic alleviation in which we'll be most closely involved, and we're also monitoring the FAA program so that if it does turn out to impact equipment in our aircraft, we'll be prepared to respond to that need as well.

But with respect to the basic research, I think we still would like to have a better understanding of some of the details of how these concepts work. I'm not quite sure about how we go about getting that, whether it's detailed flow measurements or whether it's analytical calculations; it's probably a combination of both.

MR. BLAKE: I think interest in the alleviation is very high. The detection and avoidance schemes on the ground, of course, do not work in all weather conditions, calm, windy. They're gaining practically nothing. And so our interest, I think, remains high and we're looking forward to the workshop.

MR. WEDAN: Bob Wedan, FAA. Just to emphasize that point. If you feel that the demand were there, that customers were requiring these devices on your aircraft and you were not in a position to commit actual design for a new aircraft or a retrofit,

presumably you'd be able to point out those areas where additional work needs to be done, partly by NASA and partly by the FAA in terms of, for example, certification procedures. Do you believe that that could be done in a workshop today or tomorrow?

MR. LUNDRY: Well, yes, I think we'll identify additional areas for both the NASA and the FAA to do work and in fact, I've attempted to show some of those that we consider important from Boeing's point of view. But my feeling is that we shouldn't stop. We should still explore alternatives while we still have time to do it.

MR. HODGE: Next is Clive Whitmore of the Lockheed-California Company. Clive is a Group Engineer in the Aircraft Performance Area.

MR. WHITMORE: Good morning, gentlemen. I'll keep it short, and we'll be in plenty of time for lunch that way.

In the first paper this morning presented by Mr. Sinha, I did have one question, so since I'm here now I can ask it. But he talked about closing up the separation between the airplanes on landing and takeoff and how this was going to provide additional passenger capabilities. But after my experience of coming to this symposium I've got a couple of other problems and I don't know whether they got into his analysis or not. And that one is the congestion actually in the air terminals themselves. Hell, I stood in line half an hour trying to get a ticket. This is one of the problems. And the second one I see is getting to the airport before or after your flight. These appear to be the constraints that we're faced with and if we sought out our airplane problems or our wake vortex problems are we going to step into that problem right away and was that taken in his analysis. I don't know.

Let me get on and talk before you answer and make my short presentation here. As we at Lockheed see it, we have two options right now. We have an airborne option which is essentially encumbering the airplane with the problem, and we have a ground

based option which I hoped I would have heard more about before I stood up here to talk, but I haven't, and so we're faced with these two options and we, as manufacturers, really don't know which way we're jumping. We, the airplane people, are convinced after what we've seen here today, could easily jump in there and work on the vortices at their source. Is this the right way to go? Should we try to track the vortices and stay out of them and adjust our separation depending whether the vortices are staying over the runway threshold where they'll cause an upset? And I feel, as far as we're concerned, this is our big dilemma. Do we move or don't we move and are we moving in the right or the wrong direction?

Now, what are we at Lockheed doing. Well, as you've heard we've loaned Del Croom our low-speed wind tunnel models. We've made a couple of tests at NASA Langley and I believe he's had good success with these and managed to show that using the spoilers you can significantly suppress the wake vortices. We've done some flight tests, being based upon Del, it's very convenient to test with people from Dryden and we have done flight tests as you've already seen. So I think we're convinced that using some combination of spoilers, and we may not have yet reached the optimum one, that we can suppress wake vortices to some extent.

And let me just briefly say, because I was a little concerned, people say: Oh, yes. You just stick spoilers up there and everything in the garden is lovely. Let me briefly mention what some of the design requirements for a wake vortex suppression system would have to be. And I think here we run into some unanswered questions. It's just not a simple system. It's going to be a smart system because, and we get back to it, if we do a go-around those speed brakes have got to be retracted right then. Secondly, if these speed brakes are up and we run into a wind shear or stall approach, we have to get those speed brakes down to maintain our stall margin. And this is going to take intelligence to operate those speed brakes. The FAA is not going to accept in our certification requirements that the pilot be responsible for some

action in a wind shear situation. It's got to be automatic. Now, we happen to have sensors that do exactly this on the DLC system on the L-1011. That stick shaker we have inherent in the angle of attack vane to the DLC system and the DLC spoilers are socked down, not a stall approach. Similarly on a go-around. So it's within the state of the art. But unfortunately we picked on a couple of other spoilers that we haven't got this system hooked up to now, so there's going to be expenses here. We've got to have a smart system. We've got to develop new service and I don't know what the other bits and pieces are that we'll get involved in here.

Let me talk about some of the other problems, I mean, those can be solved, all it takes is money. Let's talk about some of the other problems with using speed brakes to suppress the vortices. We touched on the drag and how this goes over into the noise problem. We're talking drag increases of maybe 10 percent, maybe 20 percent. And as Jerry Lundry showed, we're talking a couple of dB's increase in noise on the approach. The second item is if we continue to fly our current V reference, we're going to be increasing the aeroplane pitch attitude. We increase the aeroplane pitch attitude, and we start losing landing lights on the approach. You come in and you're going to see less landing lights and you're going to have to do something about that problem. Your decision height is going to be changed. Now, if you're doing Cat 3, you're in good shape, you can just do an autoland.

That brings us to the next point. We will have to change gains in the autoland system because we've changed the aeroplane configuration. I don't know how big or small these changes are. Maybe they're insignificant, maybe they're not. I don't know. We haven't done our homework there. The alternative to getting around the inability to see the landing lights on final approach is of course to increase approach speed so you get back to the original attitude. Here again you're talking about getting back into the autoland systems and having to change gains to accommodate the new speed in a slightly modified aeroplane characteristic.

Next point is that all these spoilers that we're talking about using for vortex wake suppression are used for lateral control. Every spoiler you have on a current jet is used for lateral control. Is the use of these spoilers isometrically for lateral control going to degrade their ability to suppress a vortex wake? I don't know. It's something we haven't resolved, but maybe you're going to have to put them up higher so that for instance if we talk about the 747 case where 15 was the optimum, maybe you've got to get them higher to say, 30, so that on some probabilistic approach she won't get them much below 15 on a normal stabilized approach that I believe goes with vortices sitting over the ends of the runway.

And then, finally, we come down to I think one of the hardest problems here, the go-around. And I talked on it before. You miss your approach, you hit the throttles, you go around, you sock your speed brakes in and you dump a bloody great big vortex right there at the threshold. Does everybody between LAX and Chicago go around, too? How do we sort that problem out? There's going to be a big vortex sitting there. We don't know where it is. Is the man **behind** going to have to go around? Are the two men behind going to have to go around? So these are some of the problems.

The next point here, and I think it touches the last question we had. I think most of the big aeroplanes, the 1011's, the 747's and so on, are going to be around for the next 20 years or so. And so we're talking essentially a retrofit program to take care of their wake vortices. It can be incorporated into the late production aeroplanes or whatever. So we need to know a little bit more about the system to price it. I think we had a figure like \$0.4 million or something per aeroplane. I don't know whether the \$0.4 million will cover the manufacturer's cost of incorporating the sensors and the new speed brake servos and the modified systems, because I think it may well be filled by spoilers required to get wake vortex suppression. So it could be a major modification to the aeroplane to achieve our goals

here. And I don't know whether the price is right. It's just an exercise that has to be done.

Do all airports need this? I think this is a very critical decision. We talked about the top 20 and it looked like the top 15 would probably have done a very nice job on increasing the number of passengers. If you're only doing it on 15 airports, should you modify all the aeroplanes or not? And that almost brings me back to where I started. What is the tradeoff between the ground based monitoring system and putting the load on the airplane manufacturer and the airplane? And this is again a question that I think is still open in my mind.

Now, in conclusion, I'm very disappointed to see that more of our customers aren't here. I think there are some people from Eastern and I saw somebody from United registered. These are the people really who are going to call the shots. It's going to be the airline vice president calling the manufacturer's vice president and saying, you know, it's costing us this much, this wake vortex problem, let's get with it. And then that will come down through the organization and at my level we will get with it. But at the present time we don't seem to have this commitment by the airlines that it is a big cost saver. Let me just cite you an example here of how the airlines will respond if you can show them a benefit. Some while ago we went back and talked to them about flight management systems, how they were flying too fast, burning too much fuel. Of course the flight people at the airlines, my apologies to the airlines here, say nonsense. Our pilots are supermen. They hold that mark number right on. We don't mess about. So after a little discussion we got some flight recorder tapes and looked at where the airlines were flying. Were they flying too fast, too slow, the right altitude, the wrong altitude? We analyzed these, showed the airlines the potential for fuel saving. We've got customers for flight management systems. We could show a tangible benefit that they could pay off a flight management system with fuel savings. Now, right now I don't think the airlines have an incentive at the present time. We saw a huge number there. But how do they quantify that. I

don't know. And I think when the airlines get behind this, give us a big push, I'm sure that we, the air frame manufacturers, even possibly the makers of laser velocimeters or whatever it may be that measures these wake vortices will get behind the program and we'll be off and running.

MR. HODGE: Any questions for Clive?

DR. TOMBACH: I'm Ivar Tombach. I was interested that both you and Jerry Lundry commented that the airlines were the ones who were going to determine whether vortex alleviation was going to be applied to aircraft. I suspect that economics are such that an airline would not have any particular incentive for doing so alone, ahead of other airlines, because by doing so his airplanes would cost more and put him at an economic disadvantage as compared to his competition. And I can suspect that there's a parallel here with other regulatory arrangements such as in air pollution, that although everyone would like to see it done, no one is going to make the first move unless the government forces the hand of the players. I wonder if you agree with that.

MR. WHITMORE: I think it's even worse than that. Say Airline A puts a vortex alleviation system on his airplane, he gets absolutely no benefit. It's Airline B that comes along behind him that reaps all the benefits.

MR. CROOM: There's an old proverb, something to the effect that the indian says you don't pollute the stream if you're going to drink the water. United flies behind United; American flies behind American.

MR. WHITMORE: I agree there. But it is a consideration that I think the airlines might -- I got my shot in, Mr. Sinha, maybe you can get one back at me here.

DR. SINHA: Agam Sinha, Mitre Corporation. I'd like to attempt to answer some of the questions that you raised in the beginning of your speech. The analysis that we presented is the first shot at getting at a global picture of the benefits of reduced separations and consequently it definitely does not get

into some of the details that you mentioned earlier. However, there are ways of getting at the same kinds of estimates. One is by looking at the results under demands, which was not presented here, but is a part of the analysis and will be presented in the documentation. The other way of looking at it is to reduce the percentage effectiveness of the 2, 2.5 nautical-mile standards. That is, in effect, getting you less planes on the ground if you can't handle it on the ground side. And the third point in that regard is that the specific task forces with the FAA and the industrial participants that are going on at individual airports are looking at the total picture in terms of air traffic congestions in the air and on the ground. So the results that are coming out of that study for each airport is a better assessment and it still falls within the same ball park that we presented this morning.

I would like to reiterate one of the comments you made about the *0.4 million figures and its applications*. The basic point of including that in our analysis was to reflect that it is results of analysis like these that should provide the guidelines, once you define what the problems are or what the solutions are. Once you define the cost of a spline or spoilers or what have you, then you can do a sort of cost benefit analysis that will provide the motivating factor for going ahead with it or not.

MR. WHITMORE: I agree with all you've said. I was just trying to start a little discussion. I think there was one more question back here somewhere.

MR. PORITZKY: One of the points is clearly that the airport access and terminal congestion are problems. They're really separable problems. It's different when you look at the points that I was making earlier. He also has seen clearly what you've seen and what we've seen, that the carriers up to now have not made strong representations to you, to Boeing, to the others, to get on with it. Now, it's easy to talk about the wake vortex avoidance alleviation problem and we are doing what we know how to do in that area. You will argue not fast enough and that's

fair enough. But what can be done there is limited and we have a pretty good idea what those limits are. I think the crucial point, and I hope we'll hear Frank Brady when he speaks tomorrow give us a better feeling as to what the carrier is really thinking. It's really easier to beat on FAA to do something about the ground problem, which they know and we know deals with only 30, 40 percent of the problem. And to leave in limbo what you do in the airplane. I want to touch one point that hasn't been made which is also important. I touched on the safety question earlier, particularly GA safety as congestion rises. It may not be known to everybody here that the terminal area separations, not approach and landing, but the terminal area separations are higher now than they were before the wake vortex problem was recognized. That also is a capacity constraint and when you start looking at general aviation growth and air carrier growth and increasing concentration on a few hubs and at new airports, and we don't know how to make more airports, the congestion will rise and my guess is that the safety difficulty will also rise with congestion. And no way will a wake vortex ground avoidance or detection system do a damn thing for that problem.

MR. HODGE: All right, Sig. Thank you very much. Thank you Jerry and Clive.

Now, unless Jerry Chavkin has any final comments here, we'll take a lunch break and we'll see you back here at 2 o'clock.

SESSION IV
FAA ACTIVITIES IN
DETECTION AND AVOIDANCE

MR. WEDAN: The last topic before lunch was about the FAA's interest in NASA's program. A comment was made that we have until after lunch to think through an answer for that. I believe the answer was given by Sig Poritzky. So unless -- I don't see Lou here -- he wants to restate the question, we can move on. But I think it's worth reemphasizing that the FAA indeed is interested in the NASA's program. It's been so indicated in a letter from Dr. McLukas, recent coordination meetings have reemphasized it and participation by the DOT side of the house and the programs have been undertaken by NASA. So there is no question about that level of interest.

Let me state it from a different point of view and that is that although the FAA and NASA have taken two separate approaches to the problem, NASA has indicated this morning that it's been looking at techniques for alleviation or minimizing the hazard at its source. The FAA is concerned about, given that there is a hazard there, how do we live with the hazard in whatever state that hazard is in. So it's been a coordinated effort and I think it's our belief, Sig mentioned it earlier, I would like to reemphasize it, that the approach that the FAA is taking on this will not be the complete solution to the problem. We will hear about the capabilities of the system which has been developed to date. We can speculate about improvements to the system but I don't believe that any of us believe that the approach that we're taking in terms of an advisory system will be the solution to the problem. I think in the end, to achieve the kinds of benefits that were indicated earlier this morning by Jerry Chavkin, we're going to have to approach the problem from both points of view.

Okay. By way of introducing the second half, namely the DOT efforts on this program I'd just like to state that the FAA and TSC certainly have been working the problem for many years. My own personal initial involvement goes back to 1970 so that represents the seven to eight-year effort. Much of this effort has been to develop an understanding of the behavior of vortices and ground effect, because we believed the initial hazard was the

landing problem. That isn't the total problem but certainly it's the one that we felt was worth investigating early. So a lot of time and effort was put into collecting data on the behavior of vortices and ground effect, and modeling this behavior, such that techniques could be developed for predicting the future behavior based on present measurements. And that would be of some help in assisting controllers and spacing aircraft.

The idea behind this is to find the boundary of safety and to look for a means of operating aircraft to maximize capacity, in other words, close up longitudinal separations as much as possible without compromising safety. Now, the first product of this effort is called the vortex advisory system, the VAS. You'll hear about the status of VAS now. It's an operational evaluation at Chicago O'Hare. And briefly, this is a two-state system. It's a system that will tell you when you have to use the 3, 4, 5, 6 spacing rules and when under other conditions, namely based on wind measurements, one can shorten up the spacing to a tighter spacing. So that is the first product.

The next question that we're faced with and it's one that we'll want to address more thoroughly in the workshop is the enhancement of the system. From time to time we use the term WWAS, which stands for Wake Vortex Avoidance System. It's an improvement. Basically, it takes more information for the decision-making system that will provide hopefully even further performance improvement in terms of reducing spacing. So we'll hear a little bit about that.

Now, the questions that we have with respect to the workshops this afternoon, I'll make a few more comments later on because as we step forward we've got real questions on how best to step forward from this point.

I'd like to introduce now the Chairman of this session, Guice Tinsley. Col. Tinsley has been leading this effort on the R&D side of the FAA for several years now and he will be leading the discussions and the papers that involve some of the chief participants, the chief contributors to the program on the DOT side.

Guice?

COL. TINSLEY: Well, welcome back and it looks like we didn't lose too many over the lunch period. I assure you we won't miss the 4 o'clock break and we will be in time for the cocktail hour.

Now, the objectives of this conference were four. We've taken a look at the payoffs and I think it's impressive. The amount of dollars that could possibly be saved. We're looking now at the current efforts. We've taken a look at what NASA has been doing. We're going to go through a couple of hours here of looking at what the FAA and TSC have been doing. Then you're going into the session on the operational aspects on which there has been a great deal of effort. Finally what we are looking for is the feedback on the priorities. We do have active programs, we do make decisions daily and modify our programs, but we do need your thoughts and we're very interested in what you have to say about what we're doing or what we might do.

In our fiscal year '79 activity are these major tasks. Now, these are not our priority listing of tasks but they are the things that we presently have funded and we intend to pursue. First, we're very interested in the operational evaluation of the VAS system in Chicago. We're interested in pursuing VAS enhancement and you're going to hear a little bit about that shortly. We are and will support NASA in their flight tests that are going to occur early in the year. We take our CW van out to the test site, we collect a good bit of data and then do extensive data analysis. The vortex predictive modeling is one of the few things where we're doing looking ahead to an active tracker system. In our departure vortex effort, gaining additional data on how vortices act in a departure situation to see if we can develop the same kind of thing for the approach that we had with VAS.

And then, finally, we're looking at what the WVAS requirements are. I think it's important to point out in the current activities, we are not working on developing an active tracker of any type. We are not working on sensors. The present priority, and

by priority I mean this is where we expend our resources, this is where our people work, this is where our money goes. First and more importantly we're trying to get Chicago operational and satisfy everybody that we do have an operationally viable system. Then we're going into our departure vortex study and I do not mean that we're not very interested in vortex alleviation, but the truth of the matter is this is the priority, the top three and the fourth. We are doing very little work towards a vortex alleviation system. But these are the four things that we look at as our primary priorities.

To begin Session 4 we're going to take two hours here to go through what we have done and what we are doing and where we feel we are in the vortex business. First we're going to have a vortex behavioral research talk by Dr. Jim Hallock.

Jim, if you would, please.

DR. HALLOCK: Greetings. I'm going to be talking about vortex behavior research. This is a subject that we have been working on for some time here at TSC. But what I really want to cover in this 25 or 30 minutes is a little background of what led us to the vortex advisory system, VAS, which we'll hear a lot about this afternoon. Then, my next two subjects have to do with data from two sensing systems; the results haven't been reported as yet, but some of the results are so exciting I want to spend more time on what's coming up in the future than on what's gone on in the past.

The first sensor system that we're talking about is called the ground wind vortex sensing system. This is an array of propeller anemometers that have been used at many places. They are an array of anemometers placed approximately 15 meters apart and are used to determine how vortices are moving. We think we might be able to go so far as to get some information about vortex strength, but primarily we've used the anemometers to learn how the vortices move, and when they get out of the way so that a following aircraft could come in. Well, as you can see from the slide that's closest to me, we used these anemometer arrays at

JFK, at London's Heathrow Airport, Denver, and Chicago. We've looked at in excess of 50,000 aircraft landings. So, we've looked at 100,000 vortices. We've also, at Toronto, looked at in excess of 5,000 takeoffs.

The monostatic acoustic vortex system has been used, as you can see, at four different locations, and we've looked at more than 15,000 landings and obtained very interesting data on the decay of vortices. We've also looked at some 2,000 takeoffs at Toronto.

And thirdly, we've used a laser Doppler velocimeter, the van which you may have seen out in our courtyard, to monitor wake vortices. Some laser measurements were done in the past by NASA

VORTEX BEHAVIOR RESEARCH

GWVSS: GROUND WIND VORTEX SENSING SYSTEM

JFK, LHR, DEN, YYZ, ORD
MORE THAN 50,000 LANDINGS RECORDED
MORE THAN 5,000 TAKEOFFS RECORDED

MAVSS: MONOSTATIC ACOUSTIC VORTEX SENSING SYSTEM

JFK, YYZ, ROSAMOND, ORD
MORE THAN 15,000 LANDINGS RECORDED
MORE THAN 2,000 TAKEOFFS RECORDED

LDV: LASER DOPPLER VELOCIMETER

(JFK, YYZ, ROSAMOND), ORD
MORE THAN 5,000 LANDINGS RECORDED (ORD)



Marshall and by Lockheed Corporation under contract to TSC. We are in the process of evaluating now some 5,000 landings recorded at Chicago O'Hare.

First of all, I want to talk about the ground-wind data. A lot of this is a review from what was discussed at the conference a year and a half ago, but it does set the stage for what we're going to hear for the rest of this session.

When we evaluated the data, one of the primary things that was looked at is how do vortices move and decay. The main thing we were interested in at that time was a chart like this, we were interested in the probability of vortices staying around to possibly cause a problem. Now, remember, we have no measure of strength here -- all we're saying is that there is a vortex. Is there some coherent flow that might cause a problem? Well, we found that the data looked as shown. To interpret it, for example, look at 60 seconds and move up on the curve and find a cumulative probability of 16 percent. What that means is, after a minute only 16 percent of these vortices are around. Once again, how strong is it? Who knows? We don't know. All we know is that it was a coherent flow and we could distinguish it from the background wind.

When you get out around 80 seconds or more we're only talking about some 4 percent of the cases. Eighty seconds is a key number because that maps into, at 135 knots approach speed, 3 nautical miles. We ask, what do we know about those cases that have lasted the equivalent of 3 nautical miles? What we did, and this graph by the way shows London Heathrow data, is plot all the data points where we found something that lasted for 80 seconds or more. We got a scattering of points which are enclosed by an ellipse. If I plotted all the data that we collected at all the other sites, over 20 thousand at Chicago, etc., we find that all of them fall within this ellipse. That's the key. The different symbols here are: the open circles were vortices that lasted between 80 and 90 seconds, and the dark circles were vortices lasting more than 90 seconds. So this gave us an idea that, if this ellipse is useful, maybe we can get something which will permit decreasing



PERCENT OF VORTICES REMAINING IN CORRIDOR

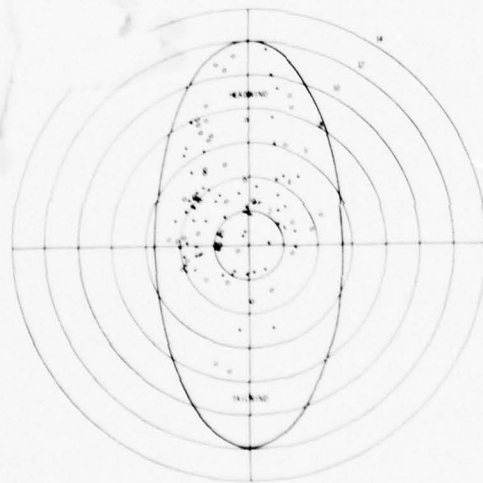
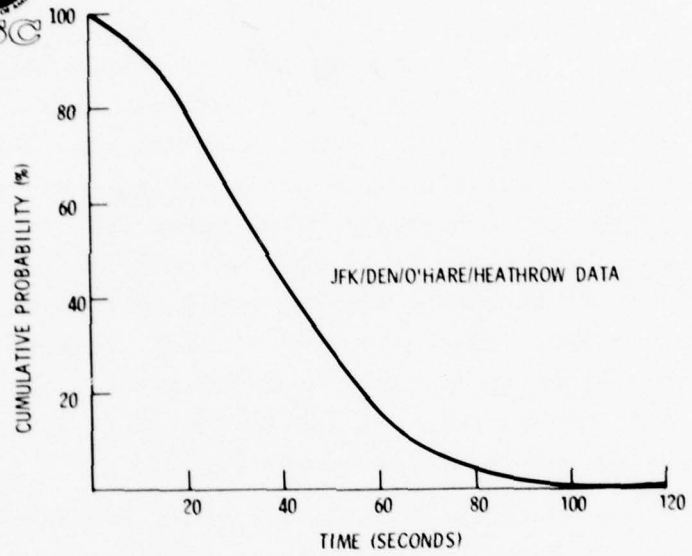

separations at airports for landings -- that's what led us to the whole concept of VAS and that will be the subject of the following talks.

One comment, just because the wind is inside the ellipse does not necessarily mean that you're going to have a vortex stay around for a long time. Quite often when you have the winds inside the ellipse, we're unnecessarily saying that you should stay with 3, 4, 5 and 6 nautical miles under IFR conditions. So, what we're also interested in is what we call VAS enhancement. Are there other measurements that we could do to make this ellipse disappear or shrink? There are some things. Things like atmospheric stability which you'll hear about later. Atmospheric turbulence also causes this ellipse to shrink to zero under conditions other than just measuring the wind.

Other types of things that we are still looking at in terms of the anemometer data is how far these vortices move. Obviously a very important question. How far apart do parallel runways have to be? Some of the measurements that we did at JFK concerns anemometer lines that stretched almost a mile in length. We're in the process of looking at this data to find out how far, indeed, do vortices travel.

Now, moving into the next subject of this talk which happens to be the monostatic acoustic vortex sensing system. Very briefly (and I say briefly because Bill Wood, towards the latter part of this session, will be talking about these sensors), what we do is send up a pulse of acoustic energy, roughly 3 kilohertz frequency, range gate it, and look at the velocity spectra.

We've come up with some rather interesting results. We now have recorded the vortices from 15,000 aircraft landings at Chicago. Here's a **typical** 747 vortex which came from the Rosamond flight test that we've heard about this morning. What we've done is transfer Doppler shifts into velocities and the result shows velocity versus the vortex radius. This case is for a 33-second old vortex that's a 33-meters height. We can calculate its circulation. Now, we see a core radius of about 3 meters.

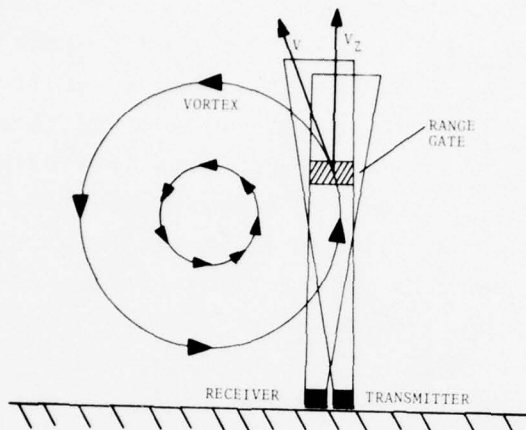

NARROW BEAM MONOSTATIC ACOUSTIC SENSOR.

B-747 VORTEX VELOCITY AND CIRCULATION PROFILES

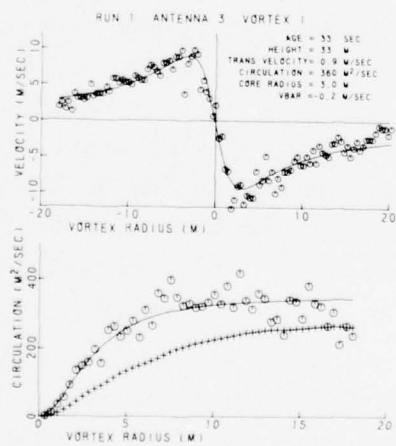

We have to define a couple of quantities. The vortex circulation definition which most people know is the product of the vertical velocity and $2\pi R$. But we have been working with a quantity we call the average circulation. What we do is take the circulation and integrate it over some radius and then weight it by that radius. The reason we're very much interested in this quantity is that under simplifying assumptions it is related to the rolling moment that you'll get on an aircraft. We also found that we can fit all the data with a simple vortex model which contains the core radius and the total circulation evaluated at essentially infinity. That's what these solid lines are. From the simple vortex model for the circulation and using the equation up here you can get the velocity. It seems to fit the data quite well.

We have lots of this data, some 15,000 cases, so we know pretty much what the velocity signatures and circulations are of these aircraft. Here are two cases which have to do with takeoff but are quite commonly found in the landing situation. They are rather interesting. What we have here is γ , which in this case is our average circulation, versus time for different radii. This is for 5 meters, 10, 20, and 30. Notice how the vortices are decaying. Taking a small radius, i.e., what a small aircraft would see if it flew into this vortex, you're not seeing much decay at all. At these higher radii, you're starting to see quite a bit of decay. What this is telling us is that the vortex is essentially redistributing its vorticity on the outer portions or the periphery and it's growing. That's where the "decay" seems to be occurring. It's not on the inside as predicted by the typical viscous-type models. The vorticity on the outer portions are moving outward faster and so we're seeing this rather rapid decay.

Another type of thing we've observed are shown in this Vugraph; all I can do is say I think the vortex is linking with the ground. We're seeing these types of behavior in take-offs and landings.

Circulation Definition

$$\Gamma(r) = 2\pi r v(r)$$

Average Circulation Definition

$$\Gamma'(r) = \frac{1}{r} \int_0^r \Gamma(r') dr'$$

Simple Vortex Model Definition

$$\Gamma(r) = \frac{\Gamma_\infty}{1 + (r_c/r)^2}$$

B-747 VORTICES, TAKEOFF CONFIGURATION
MAVSS-YYZ

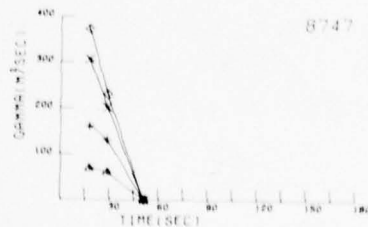
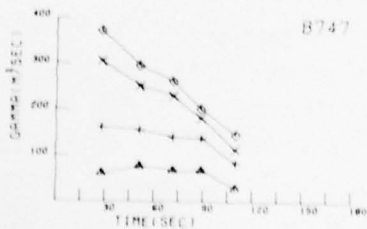

Somebody previously showed some calculations that I believe ARAP did for NASA, showing vortices coming down and then rising again. We have been able to correlate very nicely with measurements that we did up in Toronto that, given the height of the aircraft normalized to its wing span one can predict how high that vortex is going to rise. What you're doing is inducing a ground wind shear that's causing one vortex to rise much in the manner calculated by Harvey and Perry.

Another area that we're getting into which is very interesting, has to do with taking the ensemble of all the data from the monostatic system and looking at decay. What we have here in this Vugraph is for 707's. What we're looking at is the probability of finding a vortex at a given time greater than or equal to a strength, a limiting strength, versus the square of the vortex age. Notice how straight these lines are. All of the data show these straight lines and, hence, a decay going as the time squared.

One of the many things that we're looking at now is the probability of the decay of vortices to find out if the 707-300/400 series, for instance, are truly Heavy; should these aircraft be called Heavies when they're landing. Are they truly Heavy? We have a program at Chicago and we have about one thousand cases where we know the landing weights of the 707's and DC-8's. We're going to look at these types of curves to find out if we can remove a 707 that's now called a Heavy and/or DC-8 that's now called a Heavy from those categories because so doing will regain capacity.

Here is a curve that was shown by Paul MacCready a year and a half ago at the conference here, where he looked at decay measured a number of ways (ground measurements, flight data and towing tank data). As you can see, the strength is normalized by the initial strength and is plotted versus a parameter which basically is the distance measured in wing spans behind the aircraft. Roughly what's happening in the decay is that it stays constant for approximately 50 wing spans and then falls off. I've been looking at the 15,000 cases that we've collected and

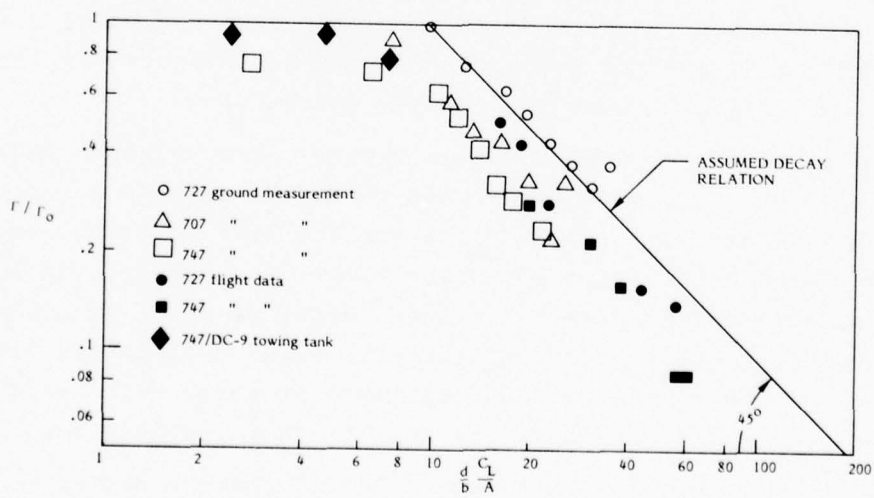
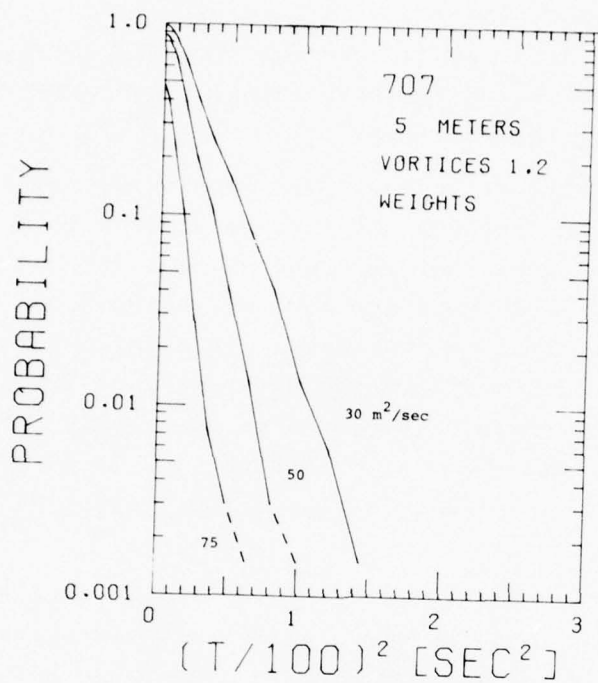

find that this form of the decay is remaining true. I could have plotted all 15,000 data points here but it would get a little crowded, but we are seeing the same thing; that curve bounds very nicely the decay of the vortices.

Changing the subject to the laser Doppler velocimeter. There are a number of ways that one can scan to study aircraft wake vortices. The initial work that was done by NASA and Lockheed used a so-called finger scan where one just moves the focus in and out rapidly and try to track the vortices. It turns out that scan was very good for tracking vortices but not very good for getting detailed measurements because, one, you're spending a lot of time at the extremes of the scan where nothing much is going on, and two, it's very hard to extract anything that tells you what the vortices are doing.

At the Rosamond flight test, the 747 flight test that you saw pictures of this morning, we used an arc scan where you just stayed at one range and scanned back and forth and allowed the vortices to descend through the scan region.

We've collected about 5,000 cases at Chicago O'Hare in connection with the VAS safety analysis. We used a stepped arc scan where we scan with one range, step down, scan back over, and so on. It takes eight seconds to scan through these eight different altitudes and you get a pretty good picture of what the vortex looks like at these various altitudes.

And as an aside, here's what a typical scan sequence looks like; these are the vortices between 16 and 24 seconds of age for a 747 on a cloudy day. You can see the familiar pattern. We have no plus or minus velocity discrimination so everything looks one sign, but you can find where these vortices are. We use a light pen technique to pick out where we think the vortices are and then calculate the angle and strength of these vortices to learn how the vortices are moving and how they are decaying.

Since we've been talking about the 747 and the use of different techniques, spoilers and non-spoilers, I thought I

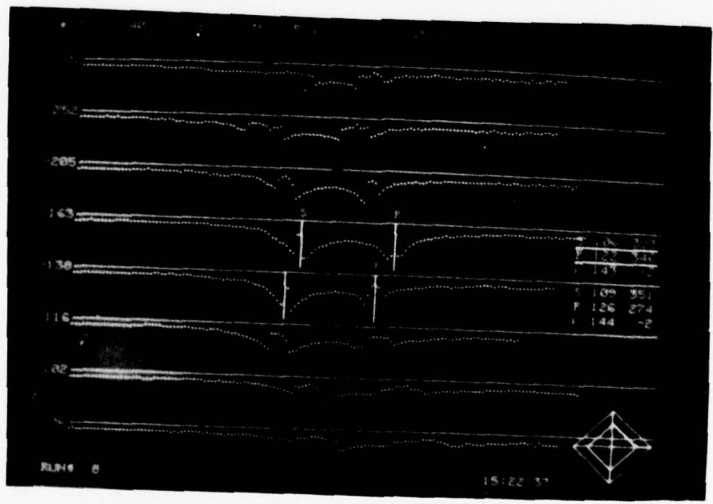
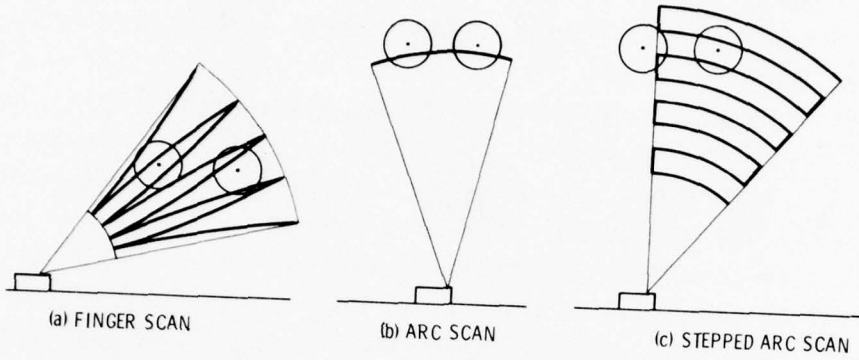

would spend the rest of the time talking about the data collected when we worked with NASA out at Rosamond Dry Lake about three years ago. What we have in this *vu*-graph is tangential velocity in meters per second versus vortex radius. What I'm showing here is just two runs; this one, the solid circles, being a run where you have no spoilers deployed (normal landing case) and the plus signs being the data when you deploy the spoilers. You definitely do see something happening. In the core region you don't see much change at all. In the periphery of the vortex we see little difference, but obviously in the central portions you are seeing quite a bit. With spoilers deployed we get a nice flat vortex tangential velocity around $7\frac{1}{2}$ meters per second. This constant velocity means that you have a circulation that's increasing linearly with distance.

Now, here are the circulations. For the next sequence of slides that we're going to see, whenever you see a scan number that's approximately the age of the vortex, within plus or minus a couple of seconds. On the right we'll have the normal landing configuration and on the left we'll always see the alleviated or spoiler case. The spoiler configuration that we're talking about is the 1, 2 and 11 and 12 case: the two outboard spoilers on both ends of the wings. I don't know if you can see the numbers so I'll read them when I refer to them. But here's something that forces us to raise the question about how well the system is operating, the spoiler system.

Look here at 5 meters, which is the size of the T-37 (semi-span); without alleviation we read a number on the order of 400 meters squared per second. Look over here and at 5 meters with alleviation and you read a number that's less than 200 meters squared per second. Definitely you're seeing alleviation for the smaller sized aircraft.

Before going on, I would like to comment that this straight line is for a Hoffman-Joubert turbulent vortex. The straight line here is from the previous slide where we had a constant $7\frac{1}{2}$ meters per second for the tangential velocity. These two lines

EFFECT OF SPOILER DEPLOYMENT ON
B-747 VORTEX VELOCITY PROFILE

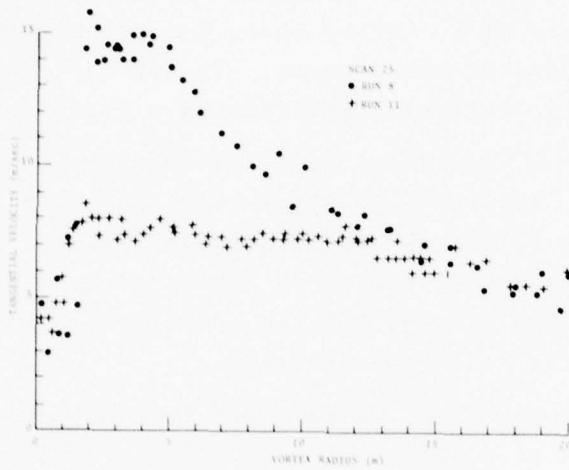

B-747 VORTEX, NORMAL LANDING CONFIGURATION
SPOILERS DEPLOYED

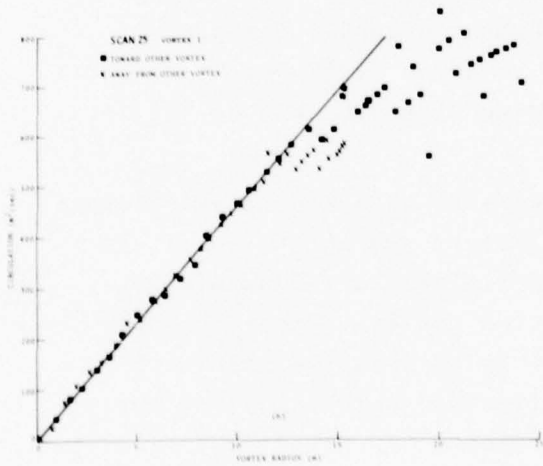

B-747 VORTEX, NORMAL LANDING CONFIGURATION

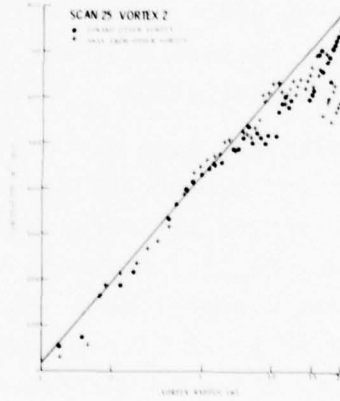

(Hoffman-Joubert curves) will remain the same in all the following Vugraphs.

Let's go back to my other problem. We saw for an aircraft that has a wing span of 10 meters that, indeed, putting out those spoilers really did show alleviation. It cut the effective strength seen by the following aircraft by a factor of 2.

Let's look at a Twin Otter or a 727-type aircraft and see what it's seeing. For the Twin Otter sized aircraft, we have a circulation in excess of 600 meters squared per second, and over here (the alleviated case) and we're seeing about 550. Not too much difference. And that is for the commercial airliners, if you will, versus the T-37-type aircraft.

Let's move along. Now, we've moved to a 39-seconds old vortex. Look here at 5 meters without alleviation, and we have a circulation around 400 meters squared per second. Look here and we're still seeing a number less than 200 for the alleviated vortex. Definitely greater than a factor of 2 improvement with spoilers deployed.

Look out here for our Twin Otter or 727 size. We're talking about a number around 550 versus a number around 400 meters squared per second. We're starting to see a little bit of effect, but certainly nowhere near the changing strength that we saw for the T-37-type aircraft.

Following the same discussion here at 55 seconds, at 5 meters we've still got around 400 for no spoilers and about 150 meters squared per second with spoilers; definitely a T-37 would have a less effect on it. Look out here for our Twin Otter; we're talking about a number near 500 with no alleviation, and with alleviation we still have a number like 400 meters squared per second. Very close to what we saw before.

Could I have the next slides, please? Now, we're getting to the old vortex; we're talking about a 3-mile separation now, 76 seconds. The dotted line, by the way, seemed to be a better fit than the Hoffman and Joubert curve. Look here at 5 meters

B-747 VORTEX, NORMAL LANDING CONFIGURATION
SPOILERS DEPLOYED

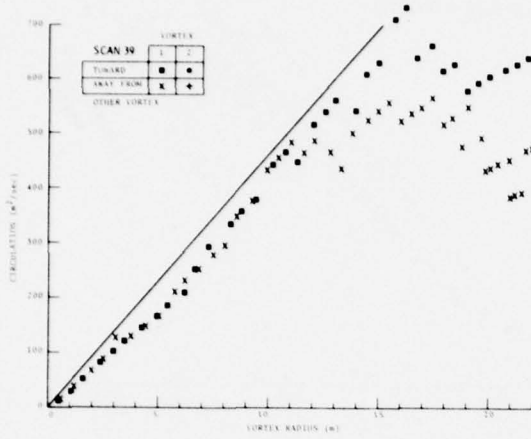

B-747 VORTEX, NORMAL LANDING CONFIGURATION

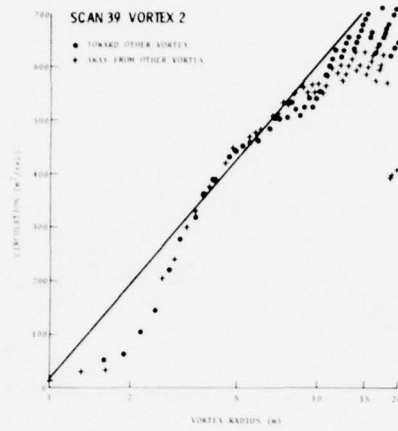

B-747 VORTEX, NORMAL LANDING CONFIGURATION
SPOILERS DEPLOYED

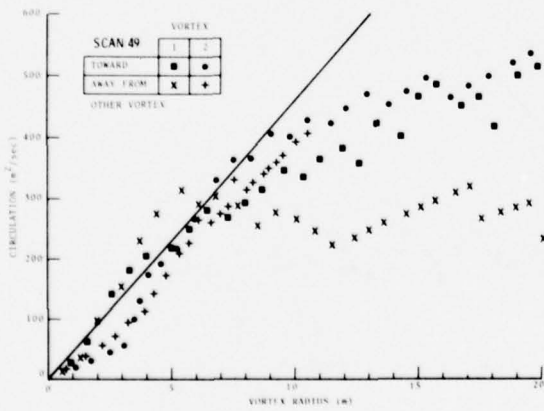

B-747 VORTEX, NORMAL LANDING CONFIGURATION

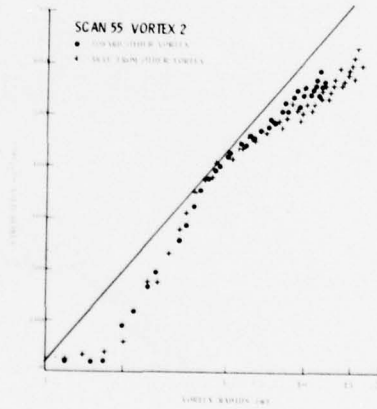

B-747 VORTEX, NORMAL LANDING CONFIGURATION
SPOILERS DEPLOYED

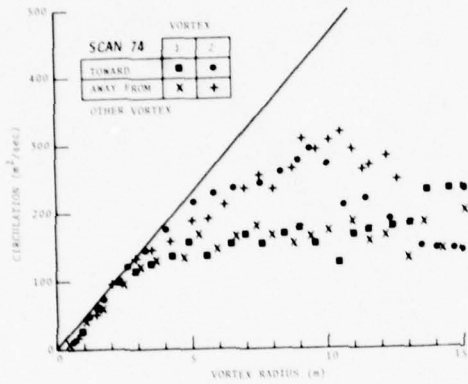

B-747 VORTEX, NORMAL LANDING CONFIGURATION

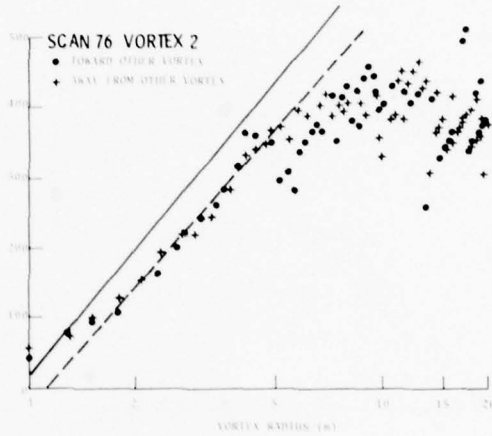

B-747 VORTEX, NORMAL LANDING CONFIGURATION
SPOILERS DEPLOYED

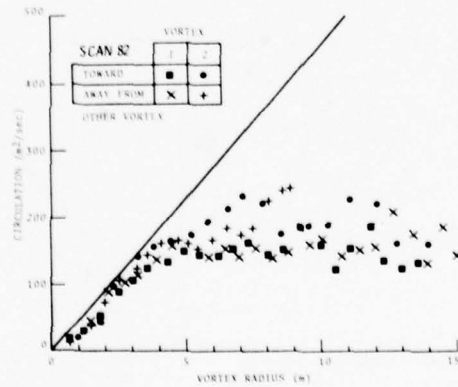

and see a number in excess of 300 for no alleviation and 150 meters squared per second for alleviation for that T-37 type of aircraft. Let's look at what happens with the Twin Otter type aircraft. We see a number around 400 for no alleviation and around 300 meters squared per second with alleviation -- not much different. You see a definite effect, but it is nowhere near as strong as it is for the smaller vortex-penetrating aircraft.

Two points I'm trying to make: With a laser we've been getting some really detailed measurements of what vortices are doing. We can learn about the decay and the velocity fields. The second point we want NASA to keep in mind in terms of these tests (and part of the reason we're going to be involved with their next series of tests); you're definitely seeing alleviation for small aircraft, the T-37 or the PA-28 types of aircraft. But the question is, are you going to see that much alleviation for the commercial airliner size of aircraft.

What I have talked about today are some of the measurements that we've done and the things that we're looking at now in great detail. We're seeing the decay of the vortex occurring from the outside in, not the inside out, as one might surmise; and we're seeing the different types of decay and we're starting to talk about why the vortices are bouncing. We've got a fairly quantitative model. We're almost ready to put equations to it to predict how much you expect a particular vortex to rise, given the altitude of the aircraft. There is a lot of other work that has been done which really was covered pretty much in the last conference.

Thank you.

MR CLARK: My name is Myron Clark. I have a few quick slides. Primarily what I brought to you this afternoon is a film that we've made on the Chicago System. Rather than go into a long and detailed discussion of some of our growing pains and the anguish we went through trying to get Chicago off and running, I'd rather show you this film. It gives you a pretty good description of how things were developed. The discussion that Jim has just held for you, if you remember back to talking about the Heathrow data, this

was the first of the data that sort of keyed us into the possibility that the wind conditions play a very, very key role in what is happening to that vortex out in the approach zone.

Just a quick statement of our objective, what we're looking for in the program, it's a capacity program. We're looking for a system by which we can eliminate or minimize the effect of wake vortex in the terminal area without compromising safety.

I'm not going to dwell on this separation matrix, you've seen several versions of it. These were the prior separations in nautical miles and what we're trying to do with the VAS is to get us all back down to 3 nautical miles between aircraft, as a minimum separation. I'd like to make that point very clear, and Jim will talk about this later.

When we talk about 3 nautical miles, using the VAS, we recognize that as our minimum. Take a good look at the situation in Chicago and how Chicago operates and many, many times you're never going to get down to 3 miles, it's just not possible because of the way the traffic is configured and how it's handled in the Chicago area.

Okay. There's some basic concepts and I think you've heard these discussed and I'm going to brush through this very quickly. Most vortices move quickly off the flight path. We can track vortices with sensors that we have and which have been under development, and I say in that slide now under development but most of that development has been completed.

Here is another picture of our infamous laser van.

And also, the last basic concept is that if we understand the meteorological conditions and the generating aircraft, there is the capability of predicting what that vortex is going to do, and therein lies the key to the future systems when you're talking about wake vortex avoidance systems.

It's really a very simple system. It's composed of three basic subsystems.

First, you have your met towers that are located in the approach zones -- they are fifty-foot towers. We have a triple anemometer configuration. There is a central data processing unit. It's located in the IFR equipment room, downstairs at the base of the tower, O'Hare Control, and then we also have the displays for the controllers.

Now, in this slide you're only seeing one display which is what we call the individual controller display. I also have another picture of that here, I think, coming up.

Here again, is Jim's algorithm. He's already discussed that pretty thoroughly, although we did coordinate with each other on what our briefings were going to be, unfortunately, we did manage to double-up on a few of these things.

This is just another depiction of it. It does show you the head-wind, cross-wind components, and that transition band that we use. If the wind vector is inside the inner ellipse then you have what we call our red condition and you use your standard separations.

Once the wind vector goes outside the outer ellipse of course, that gets us our green condition, which we say, okay, now we can close down to three miles between aircraft.

This band that you see is a transition zone or a buffer that we've built in to allow us to keep the system from flickering back and forth too much, which would drive the controller right up the wall, of course.

Here's the other display that I was going to talk about. The individual controller display. He controls the runway that he wants to look at with this thumbwheel switch here. He dials up an arrival for runway 09 left, or if he's working 9 right, 27 left, 27 right, or whatever.

If he does make a mistake and dial in 24, which doesn't exist in Chicago, the system will blank out, show no data.

We do have the two separation lights here on this corner. This also gives him the wind direction, the wind speed, and gust,

if any, and there is a dimmer control and some other switches on it.

This display right here is what we call the system monitor display. This is an overview-type display. We call it the supervisory display. If the supervisor wants to take a look at his airport and what the wind patterns are doing, he has all of the tower's, including the center field wind, displayed on this unit. It also has the separation lights, and thinking ahead in the future for departure considerations, we do have some spare module capability where we can add, if we are successful with departure studies, an algorithm that will perhaps give us a capability to handle departures with this same system.

This is a close-up of the anemometers on the met tower. There are seven of these towers to cover the twelve approach corridors in Chicago. This is a picture of the hardware at the base of the tower. This is simply the guts of what's hidden in that box down at the bottom of the tower where we convert the analogue signal from the sensors into a digital signal and transmit it back to the central processing system.

Now, that's all the slides that I have and that leads me into the film, and just one comment before we start the film -- This film was prepared really to be distributed to anyone who would like to have a film with a basic description of the system. We have not released the film yet, because, if you listen closely, it infers that the Chicago system is already in operation.

We didn't want to create problems and a lot of questions, so we've been held off on releasing the film. This, in the trade, is called an answer print. It's the only copy of the film that I have. We will do some minor modifications. There's a couple of words in here that we think need to be changed around before the final film comes out.

One last point to be made. This film was made when we still had our engineering model in Chicago and so you'll be seeing some met towers and some pictures here that don't quite match up with what you would see in Chicago today.

Mr. Projectionist, if you will roll the film, please.

Although we have an FAA logo on that and we take credit for it, I guess I ought to thank the NASA folks for their film clips.

You probably recognize some of that file, Joe. Some of it came from your files.

By the way, I did want to point out to this group that this film wasn't designed for all of you. This was our attempt to develop a familiarization or an orientation film, that we could distribute throughout our regions so that our controllers and the user groups that wanted to see what we are doing with the Vortex Advisory System. It really was not designed to be a highly technical film, although I think it tells the whole story on how the system grew.

One other point that I would like to make about Chicago. From our point of view, we have basically completed the development at Chicago. We are working on doing some of the final analysis of the laser data that was taken out there, and you're going to hear some more about that from Jim Hallock shortly, but basically, the system's development effort at Chicago has been completed.

We have some minor technical problems that we are policing up at the present time and we are in the process of publishing a handbook and getting the system specifications completed. So, basically, the Chicago Vortex Advisory System development has been completed at this time.

One last item that I would like to point out. We did certify the system, or at least turn it on for the wind information. We have been using the wind information taken from the anemometer network at Chicago since last May. If you are flying into Chicago and ask the tower for the winds on final, you will get the wind measured in the approach corridor for the runway which you're landing on.

Now, the other general information -- weather information is still centerfield, but if you request wind information, the

wind that you get from the tower or the TRACON people is the wind taken from the approach corridor for your runway.

Unless there are some questions, gentlemen, that's all I have.

FROM THE AUDIENCE: Myron, what is the status of it?

MR. CLARK: It is permanently installed in Chicago, and I think you will hear more about that later from some of the other group that's coming up, Joe and Gene Barlow.

We're planning right now an operational evaluation and, hopefully, the last date we heard was sometime early this spring we should be ready to do an operational evaluation, and then the system is permanent in Chicago. It'll become part of the Chicago traffic environment.

Any other questions, gentlemen?

Thank you very much.

MR. TINSLEY: You can imagine that with any change that we're making to the air traffic system, we're very concerned about the safety aspects, and one of the things that Dr. Hallock has been working on is a safety analysis, and he's quickly going to go through it and tell you some of his rationale. Jim?

DR. HALLOCK: The subject of this portion of the session is what we call the VAS Safety Analysis. I don't expect that in the next twenty minutes I can convince you that the safety is proven absolutely. What I would like to do is show you the rationale, that Guice mentioned, to at least show you, and, hopefully, convince you that I've approached the problem in a logical manner.

It is a very interesting fact that most of the vortex-caused accidents have occurred in the middle marker to touchdown region. In fact, over three quarters of the accidents -- this comes from a study done by Mitre where they studied ten years' worth of accident data -- occurred on landing, and of these landing accidents, in excess of eighty-five percent of them occurred between the middle marker and runway touchdown region. Thus, that

VAS SAFETY ANALYSIS

- MOST VORTEX-CAUSED ACCIDENTS OCCURRED BETWEEN MIDDLE MARKER AND TOUCHDOWN REGION
- VAS ALGORITHM (THE ELLIPSE) DERIVED FROM VORTEX DATA COLLECTED BETWEEN MIDDLE MARKER AND RUNWAY THRESHOLD
- CAN PROTECTED REGION BE EXTENDED OUT TO OUTER MARKER?

justifies, if you will, the thousand upon thousands of vortex tracks that we have been collecting in this region.

Since we have been collecting the data there, that's where the VAS algorithm, the ellipse, was derived.

Now, one can go ahead and say that, here is a system that will allow you to decrease separations from the middle marker to runway threshold. Conceivably, if you look at the mathematics, you will get some benefit but, admittedly, it's going to be rather small. So the question becomes, and that's the subject of this talk: Can you extend this protected region from the middle marker out to the outer marker? If you can decrease separations from the outer marker in, you're talking about a system where you now can get measurable changes -- well, at least we hope they're measurable.

How do you do this? Well, what I did was to put together a very mathematical computer model based on what I think happens with vortices, how they move, how they dissipate, and how aircraft will, in a very simple manner, react to vortices.

This model has simple inputs to the calculations. How do aircraft fly the ILS? We happen to have some data that have been published by the FAA. We have made our own measurements at Chicago and confirmed these measurements.

How do vortices descend? Well, it turns out we have some information since we've measured initial descent rates of vortices. As you can see, for a 747 we can get means and standard deviations, which anyone who is trying to do probability must have.

The other input that we need in this particular model is vortex decay, and that's why I told you previously to remember that one particular slide that showed that the decay seems to be negligible for about fifty wing spans behind the aircraft and then falls off essentially as the reciprocal of time.

The next thing you need for the analysis is the cross winds aloft. Now that, admittedly, is the most ticklish part of the

INPUTS TO CALCULATIONS

DISTRIBUTION OF AIRCRAFT ABOUT ILS CENTERLINES

VORTEX DESCENT

VORTEX DECAY

CROSS-WINDS ALOFT

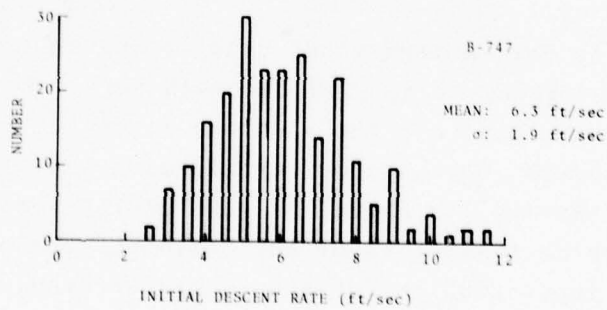

INITIAL DESCENT RATE OF B-747 VORTICES

whole calculation. We've gone through a rather rigorous derivation of what we think the cross winds aloft are, and we've used this in the model. What we think the cross winds are when you have a green light situation versus what you have with red. One of the purposes of taking the laser system out to Chicago to collect data was to measure the cross winds aloft.

At times when there were no aircraft using the runway where that laser was set up, we used the laser to collect wind information -- What was the wind at 400, 600, 800, and 1000 feet above the ground and correlated it with what the VAS system was telling us the wind was.

What I'm trying to show you in this Vugraph are the steps in the analytical process that I've followed. What I'm reviewing in this short talk, is a document that has been written and has been distributed to ALPA, ATA and a number of other organizations to review and criticize; eventually it will be published as Part One of the VAS safety analysis.

The second volume of this analysis will be the analysis of the laser data collected at Chicago. There are over five thousand cases to show whether, indeed, the model that I constructed is good or not.

What I did is very mathematical using error functions -- that's why I'm not going to go into the math here. But the first thing I did is ask: What are the ordinary risks accepted in the present system today? What are we experiencing now with 3, 4, 5 nautical miles? Notice I'm saying 3, 4, 5 nautical miles. The reason is that we're talking about the region of the outer marker -- the six-mile separation is for the runway threshold region.

The model is then used to calculate the minimum distance in nautical miles required to reduce the probability of a vortex hazard to zero.

What these numbers on the Vugraph mean, for instance, is that for a 747 as the lead aircraft; if you were in a PA 28, you've got to be back around $8\frac{1}{2}$ miles before you'd be at a point

STEPS IN ANALYTICAL PROCESS

1. CALCULATE ORDINARY RISKS IN PRESENT SYSTEM
(3/4/5 NAUTICAL MILES)
2. ESTABLISH BASELINE PROBABILITY AS MAXIMUM ACCEPTABLE RISK
3. CALCULATE NEW RISKS EXPECTED WHEN USING 3-NAUTICAL-MILE SPACINGS DURING VAS-GREEN CONDITIONS
4. FORMULATE OPERATIONAL GUIDELINES TO MAINTAIN RISKS WITH VAS-REDUCED SPACINGS AT OR BELOW BASELINE RISK
5. PERFORM SENSITIVITY ANALYSIS ON CONCLUSIONS
6. COMPARE CONCLUSIONS TO AVAILABLE INFORMATION
7. FORMULATE REFINED OPERATIONAL GUIDELINES AND RECOMMENDED ACTIONS

CALCULATE ORDINARY RISKS IN PRESENT SYSTEM

MINIMUM DISTANCE IN NAUTICAL MILES REQUIRED TO REDUCE HAZARD TO ZERO

LEAD AIRCRAFT	TRAIL AIRCRAFT											
	747	DC10	L1011	DC8H	707H	DC8	707	727	DC9	737	LEAR	PA28
747	2.3	2.5	2.4	2.7	2.6	2.8	2.6	3.2	3.6	3.5	5.5	8.5
DC10	1.6	1.6	1.6	1.8	1.7	1.9	1.8	2.1	2.4	2.3	3.6	5.7
L1011	1.5	1.7	1.7	1.9	1.8	1.9	1.8	2.2	2.5	2.4	3.9	6.1
DC8H	1.5	1.6	1.5	1.7	1.6	1.8	1.7	2.0	2.3	2.2	3.5	5.5
707H	1.4	1.5	1.4	1.6	1.5	1.7	1.6	1.9	2.2	2.1	3.4	5.3
DC8	1.3	1.4	1.4	1.6	1.5	1.7	1.6	1.9	2.3	2.2	3.8	6.0
707	1.4	1.5	1.4	1.6	1.5	1.7	1.6	1.9	2.1	2.1	3.1	4.8
727	1.1	1.2	1.2	1.3	1.2	1.4	1.3	1.5	1.7	1.7	2.5	3.9

where the probability of a vortex hazard would reduce to zero in my model.

Interestingly enough, I'm happy to say that many of the numbers on this Vugraph agree with numbers we heard this morning. Some of these do not, but most of them do.

Another case to point out -- you remember there was an accident with a commercial airliner, a DC-9, following a DC-10. I calculated a separation of 2.4 nautical miles. Well, the accident occurred with less than two nautical miles separation. The cases that are circled on the Vugraph are all numbers greater than three, because those are the ones that I'm going to have to talk about here; the shaded numbers are the ones that are greater than what the IFR standards are.

It doesn't mean that just because some calculated values are greater than the IFR standards that maybe we don't have the right standards. What you don't have folded in here (I think Joe Tymczyszyn mentioned it in his talk) is the fact that these vortices aren't staying around; that is, they are moving around. The winds are blowing them away or they are descending well below the flight paths. That's what brings it down to the fact that we don't have any accidents when the aircraft are flying at the 3, 4, 5 and 6 mile separations.

Now that I've calculated what I call the risk, what is the probability of their being a vortex hazard? Hazard to me means a rolling moment imparted on your aircraft that you would not want to accept. The Ames simulations came up with numbers like, I believe, ten degrees of roll when you get near the ground. You don't want to get anything more than that if you're on an IFR approach.

We're working with small probabilities; whenever you work with small numbers, you've got to question what you're doing. So, what I've done is to use the following technique. The accidents occurred with less than 3, 4, 5 and 6 nautical miles spacings, so whatever the calculated probabilities for a vortex hazard at

these spacings, let's at least say that should be an acceptable probability because accidents aren't occurring, and that's what I call a baseline probability.

Then what I do is use my model and ask, what are the risks when we have a VAS green condition? What I'm going to insist upon is that when you have reduced spacings during a VAS green-light condition, the probability of a vortex hazard must be no greater than the numbers that we are accepting in today's 3, 4, 5 nautical mile system.

In other words, whatever the probability that we are accepting in today's safe system, I'm saying that when you turn on the VAS and reduce separations to three miles, the probability of running into a hazardous vortex will be no greater than what you are accepting in today's system.

What do we have to do to make sure that we maintain risks at these VAS reduced spacings, at or below this baseline value? Well, the first thing we have is, don't use reduced spacings unless you've got a green light. The next thing is, and this is rather important, when using the VAS, the aircraft must use precision approaches. We don't want short finals or localizer approaches, or VOR approaches. The reason that VAS can get closer separations is that that vortex has descended well below the flight path. If you're making these other type approaches, you could be coming in just where that vortex has moved.

Thus, the VAS requires precision approaches from the outer marker in. I'd like to reiterate a comment that Myron made because it is very important. We're always talking about three miles. Remember that we've got at least five miles separation to the outer marker. The VAS system is going to gain all the benefit from the so-called accordion effect. Because the first aircraft is slowing down to land, the controller adds a buffer (an extra half-mile or so) to the interarrival spacings to insure that the IFR separations are maintained.

What we're saying is, you don't have to worry about the buffer anymore. You've got to have the aircraft at five-mile

separations outside the outer marker, but when the VAS is green the controller can let them close up.

I did all the calculations using three miles as the closest separation. I believe that most of the aircraft are really going to be more like three miles for the 727 following a 727, but more like four to four and a half miles for a Heavy followed by a Large.

I have to stop here and point out one problem that we have, a philosophical problem, which I thank Agam Sinha for pointing out to me. When you are comparing probabilities, particularly small ones, and try to be as conservative as I have in all the calculations, there could be a possible philosophical problem. Without going into the details, we're doing two things: First, you don't run into the problem if all you consider are the Heavy and Large categories of aircraft. According to my analysis and according to the brief look at the laser data, you could start VAS now only for the Heavy and Large series of aircraft and exclude the Smalls until we resolve the philosophical problem -- that's what we're proposing. The problem only affects the analysis for the Small aircraft following Heavy or Large aircraft. We are looking at this philosophical problem and hopefully if it is resolved favorably, maybe by the time the VAS is activated for the operational test at Chicago, we will be including all the aircraft.

The next thing that I had to do was to examine the sensitivity of the model. What I've done is take the models and drive them to their limits such as having the first aircraft come in at its stall speed and having the other aircraft coming in at 240 knots. Even changing to these various limits still does not change the overall conclusion that the VAS should be a safe system.

Now compare these calculated results to available information. That's the primary reason we took the laser system to Chicago and set it up where the aircraft are approximately 700 feet in altitude, and tracking the vortices and correlating the results with what the VAS system was saying. When it was a

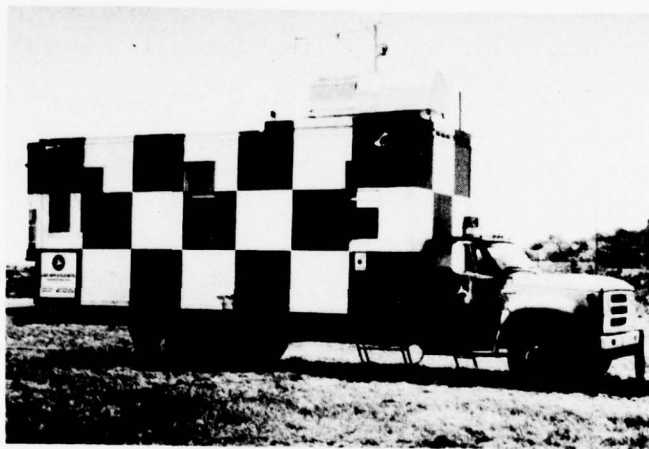

green light, did we see anything that would say that any part of my analytical model is wrong? Remember, we had four ingredients: how the aircraft were flying the ILS; how the vortices were moving and descending; how the vortices decayed and how the cross winds varied.

All of these quantities are being double-checked by looking at the laser data. To date, I have seen nothing to say that my model is incorrect or should be changed.

Two other things are suggested as being possible reasons why you should think the VAS might be safe. One is VFR. As you know, when you operate under VFR conditions, you are using less spacing than the 3, 4, 5 and 6 nautical miles and aircraft are safe for the most part.

As another thing, this is a slide made by Ollie St. John which he showed at the conference a year and a half ago. What we're looking at here are the results of an incident reporting system. The British have had this system for a number of years now. Whenever a pilot thinks he has encountered a wake vortex, he fills out a rather detailed questionnaire. The CAA then gets detailed meteorological information from the meteorological office at the airport and the flight data recorder and really study them to see what happened.

What I've plotted, or I should say what Ollie St. John plotted, is our VAS ellipse and all the incidents that occurred between the runway threshold up to an altitude of a thousand feet above the ground. I don't want to say this is proof of the safety of VAS because the British measured the wind differently than we do in the VAS. They measure it at a different location, but what I'm trying to say is that there's nothing here that disproves that you can use the VAS for decreased separations.

There are three data points which I admit fell outside of the ellipse. These three data points occurred where the aircraft were at a thousand feet in altitude. Two of the points are plus signs; that means the pilot reported a roll angle of less than ten degrees. To me, I don't find that to be too much of a

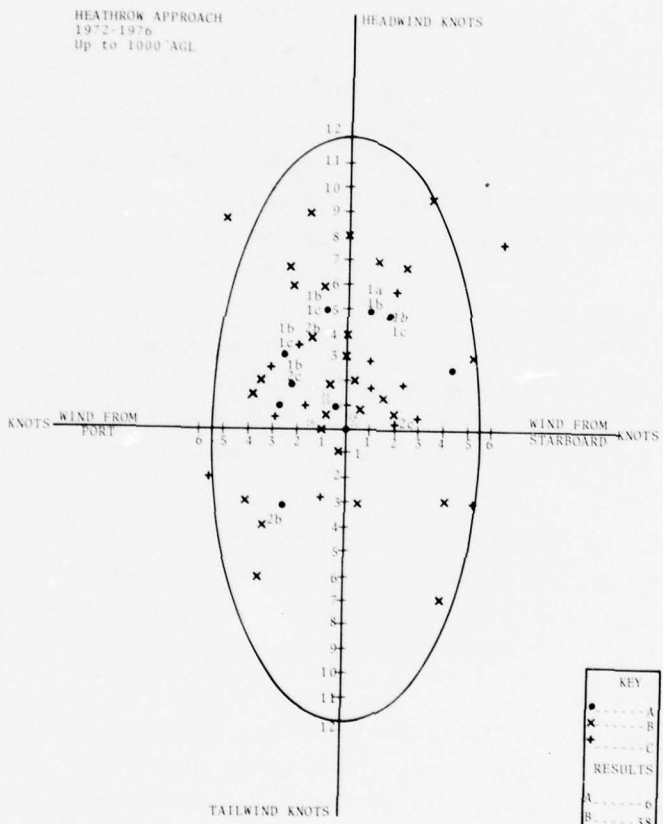

problem, but as a passenger, I must admit, I would think it was twenty or thirty degrees. The other point was for between ten and thirty degrees roll as reported by the pilot. I underscore that because other measurements indicate that when the pilot reported he went through a fifty-degree roll, typically the flight data showed it was half that.

Finally, we formulate operational guidelines. Primarily, what I'm pointing out here is that now we're just talking about a system that will work for a single runway. Remember in my previous talk, one of the things we were worried about was how far vortices move. If you have a six-knot cross wind the ellipse indicates that VAS-reduced separations could be used. But if you've got a parallel runway that's four hundred feet away, as you do at some airports, that's no good because a vortex could get over there. Something more has to be done. This doesn't mean the VAS can't be used. It's just that we have not put in the logic as yet to permit you to use it for more than a single runway application.

MR. TINSLEY: We asked Jim to compress an hour lecture into twenty minutes. I think he did a good job. He'll be around tomorrow. So, if you have any questions or want further explanation on this, he'll certainly go through whatever details you would like.

We have Hector Daiutolo with us from Atlantic City, NAFEC, a test evaluation group there. He's going to briefly go through the planning that's gone into the operational demonstration that we plan to do at Chicago. So, Hector?

MR. DAIUTOLO: Thank you, Guice.

At the FAA's experimental center at Atlantic City, NAFEC, the role in the VAS program is two-fold; first, to provide an evaluation of the system during its operational demonstration at Chicago O'Hare, and to previously have tested its procedural implications -- the procedural implications of implementing it in the O'Hare environment through air traffic control simulation.

This was done in 1977. Today's briefing will concentrate, as Guice had mentioned, on the elements involved in operational evaluation and the conditions that may present themselves at Chicago O'Hare. The simulation results, though, bear fairly heavily on this, and constant reference will be made to those results.

These are the elements that might make up the operational evaluation. The system is being evaluated for operational suitability.

A further breakdown. The gross check for effectiveness of the VAS system, as mentioned by many of the briefers today, is the increased arrival rate, that is obtained with the system during the green condition, when it shows the green reduced separation condition.

These are some of the elements that might be listed under procedural implications. Controller performance and controller workload have already been tested by simulation with very favorable results. It goes almost without saying that controller acceptance and pilot acceptance were not tested in the simulation; they being merely inherent in the very ground rules by which the simulation was run.

The elements involved in system reliability and maintainability are listed. Today's briefing will concentrate on effectiveness and procedural implications, and the things that are more unique to VAS. In the long run, it may wind up that the reliability and maintainability study is not particularly unique or different from the evaluation of those same things with other systems.

These are some of the data sources that will be tabbed. We'll only point out the very most important ones. In the O'Hare tower, the radar tracking tapes will tell virtually the complete story. How the various class pairings of aircraft are separated with and without VAS.

NAFEC ROLE IN THE VAS PROGRAM....

↘ OPERATIONAL EVALUATION

↘ SIMULATION EVALUATION

DEMONSTRATION OF VAS AT CHICAGO O'HARE

- OPERATIONAL SUITABILITY
 - EFFECTIVENESS
 - RELIABILITY AND MAINTAINABILITY
 - PROCEDURAL IMPLICATIONS

OPERATIONAL SUITABILITY

- EFFECTIVENESS
 - INCREASED ARRIVAL RATE
- PROCEDURAL IMPLICATIONS
 - CONTROLLER ACCEPTANCE
 - CONTROLLER PERFORMANCE
 - CONTROLLER WORKLOAD
 - PILOT ACCEPTANCE
- RELIABILITY AND MAINTAINABILITY
 - ANALYSIS OF SYSTEM MALFUNCTION
 - MAINTENANCE REQUIREMENTS

ON-SITE DATA SOURCES

- O'HARE TOWER
 - DAILY LOGS
 - ARRIVAL/DEPARTURE REPORT
 - RADAR TRACKING TAPES
- CHICAGO CENTER
 - ARRIVAL DELAY REPORT
- NATIONAL WEATHER SERVICE
 - SURFACE WEATHER OBSERVATIONS
- TSC DATA ACQUISITION SYSTEM
 - VAS INDICATIONS

Down at the bottom of the Vugraph, the VAS indications are recorded by the TSC Data Acquisition System. What VAS is saying -- not only on the runways in use, but on all the runways, it will present the VAS scenario as seen by the controllers at any given time.

Some additional data sources that are self-explanatory.

Again, we've emphasized the fact that the final approach spacing are the very key to the measure of system effectiveness. Counting the aircraft does give you the gross measurement, but you can tell where the game is being won or lost. The spacings will tell virtually the complete story.

Those spacings, augmented by the final approach speeds, will give you the arrival rates anyway.

All this has to happen in some kind of environment. The elements listed in the Chicago O'Hare environment -- some of them that will be examined during the demonstration, are listed here. They provide more or less the elbow room within which VAS has to work. The data sources that you saw a little earlier have already been tapped to provide a baseline as to what that elbow room might be before we actually go ahead and demonstrate the system.

We'll take a look at some of those. First, the arrival rates. Arrivals per hour over a typical day at O'Hare in 1977, during what might be loosely called the daylight hours. Notice that the traffic peaks in the afternoon, between one and three and between four and seven.

Examination of the radar tracking data show that indeed at these times, the various class pairings of aircraft do approach the prescribed current minima, separation-wise. Any gains in arrival rates at this point or at these times are dependent entirely on a system such as VAS.

In the morning there is still some latitude within current prescribed minima where gains could be achieved. At these times, VAS may not show maximum effectiveness. The afternoon hours will

(ON-SITE DATA SOURCES con'd

- NAFEC
 - CONTROLLER QUESTIONNAIRE
- ALPA
 - PILOT COMMENTS
- CONTRACTOR
 - REPAIR ACTION EVALUATION
- AIRWAY FACILITIES
 - FACILITY MAINTENANCE LOG

VAS Effectiveness

As Related To O'Hare Terminal Environment

- EFFECTIVENESS
 - INCREASED ARRIVAL RATE
 - FINAL APPROACH SPACINGS
 - FINAL APPROACH SPEEDS
- ENVIRONMENT
 - HEAVY DEMAND PATTERNS
 - VISIBILITY CONDITION PATTERNS
 - RUNWAY CONFIGURATION USAGE
 - DEPARTURE RATE
 - ARRIVAL TRAFFIC MIX
 - ARRIVAL PAIRING MIX

Arrival Rates - Typical Day 1977

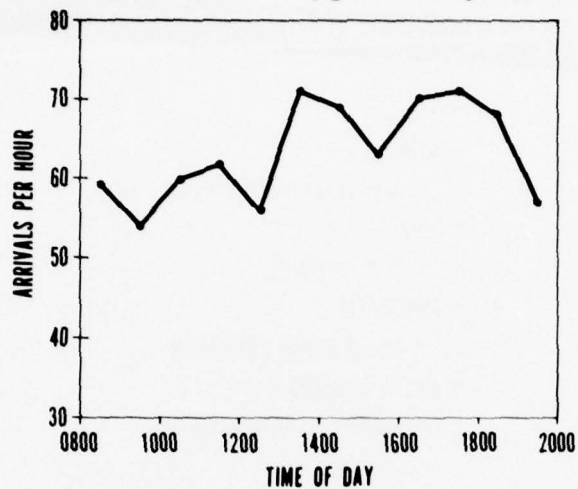

Visibility Conditions During Daylight Hours 1977

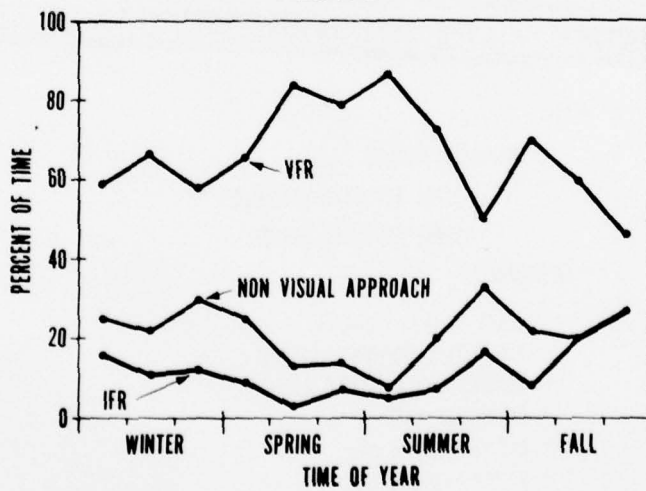

show the maximum effectiveness. So, we're talking about five hours out of twelve, perhaps forty-some percent of the time.

Looking at the distribution of visibility conditions by percent of time over the seasons, we can't exactly say last year was necessarily a typical year, but the patterns are rather similar. Note that -- Well, starting first with the IFR curve. In instrument Flight Rules we have complete control of the traffic by the controller. Generally, the visibility is less than three miles, and ceiling less than a thousand feet.

Just above that, we have the lower limits of the VFR which are technically the VFR conditions. Visibility less than 5,000 feet and ceiling less than 3,500 feet. Again, technically, these are VFR conditions, but under these conditions at O'Hare, visible approaches are not approved, so that the operations are essentially IFR in nature.

The IFR in non-visual approach conditions comprise the controlled approach conditions, where the controller virtually has complete control of the aircraft to touchdown. It's under this situation that VAS is expected to show again its maximum gains.

Under VFR, at the top, control of the aircraft is passed off much earlier in the landing cycle. The pilot is cautioned on wake turbulence and he has already at his option the ability to close the gap to three miles. Not too much is expected there, if the system will even be used under VFR. It probably will not.

Examining the VFR curve then, it more or less gives us the percentages of time more easily than summing the other two, but VAS is expected to show maximum effectiveness: in the winter, about forty percent of the time; as you approach the spring and summer, perhaps about twenty percent of the time.

If we combine those percentages and overlaid the percentages of the arrival rate condition, we're winding up with periods of time for VAS maximum effectiveness, not just any effectiveness at all, but maximum effectiveness of about sixteen percent in the winter, and about eight percent in the spring.

These statements are not intended in any way to demean the value of the system. Even under these constraints, the various research analysts have presented analytical studies that showed a system can pay for itself many times over within one year. They only serve to highlight the fact that if someone is doing the evaluation for system effectiveness, it's important to be very selective about the hours that are actually examined.

These are some of the favorite runway configurations. By, all non-visual approach conditions, we were including the IFR. The second and third of these were selected in the simulation. They actually rank very close. There's little to choose between them.

The point to emphasize here is that if some kind of statistical base is to be achieved in the evaluation, favored runway configurations have to be considered.

The O'Hare traffic mix -- It's self-explanatory, what that means with respect to how VAS might operate at Chicago O'Hare specifically. This is the matrix you've seen several times today. The current prescribed minima.

Now, VAS is operating and VAS is green. We do separations. The first thing that happens is that a Small aircraft can be treated similar to a Large. The requirement that a Small aircraft be in trail of a Heavy at six miles and in trail of a Large at four miles only applies when the lead aircraft, the Heavy or the Large, is over the threshold. When VAS is implemented in Chicago O'Hare, it's expected that it's sphere of influence will at least extend to the outer marker.

So that lead aircraft will be touching down in a zone for which the system says, no vortex. So this becomes the matrix.

Gains here, even with this small increment, can be between one and two percent in the arrival rate.

Looking further, it is in the ultimate resolution of the aerodynamic question, it's determined that aircraft can only pass below the prescribe minima in separations between the outer

ARRIVAL TRAFFIC MIX

1977

HEAVY

15%

LARGE

75%

SMALL

10%

MINIMUM AIRCRAFT SEPARATIONS
Current Standards

LEAD TRAIL	H	L	S
H	4	3	3
L	5	3	3
S	6	4	3

VAS GREEN CONDITION

Small Aircraft Can Be Grouped With Large

LEAD TRAIL	H	L	S
H	4	3	3
L	5	3	3
S	5	3	3

VAS GREEN CONDITION

Dual Separation Standards

LEAD TRAIL	H	L	S
H	3+	3	3
L	4+	3	3
S	4+	3	3

marker and touchdown, then these separations have to apply, as Doctor Hallock pointed out, when the lead aircraft is over the outer marker.

It is only the natural compression that occurs between outer marker and touchdown by virtue of the speed reduction profiles, the trail overtaking the lead, that gains will be achieved, and that will look something like this, in most likelihood.

These probably will be the minimum separations achievable. We get this from the fact, the known fact, that a study of the tracking data shows that aircraft overtake each other at O'Hare almost regardless of categories from between one sixth and one eighth of a mile. This is also verified in simulation. This isn't expected to change with VAS, because no speed control is contemplated on behalf of VAS between the outer marker and touchdown.

Now, again, if in the ultimate resolution of the aerodynamic question in the area outside of the outer marker, if consistency of vortex descent and ability of the aircraft to stay within prescribed minima in the flight path locations, the system may prove itself to be safe in the whole terminal zone. This really was the ultimate goal of VAS. It's probably still an open question whether it will or will not be shown to be the case. It's under study at the present time.

If that happens, the ultimate goal is achieved and all aircraft come in at three miles. By the way, the gain on the previous Vu-graph with the dual set-up for separation criteria was about four percent.

Now, we're getting into the seven percent range here. This is the same matrix. We're looking at it a little bit differently. With respect to percent of occurrence, notice that 78 percent of the traffic at O'Hare already comes in at three miles, so that VAS will be addressing 22 percent of the traffic. Twenty-two percent of the traffic, a maximum of about sixteen percent of the time for maximum effectiveness.

VAS GREEN CONDITION
Single Separation Standard

LEAD TRAIL	H	L	S
H	3	3	3
L	3	3	3
S	3	3	3

ARRIVAL PAIRING MIX

1977

LEAD TRAIL	H	L	S
H	3%	78%	
L	11%		
S	2%	6%	

These are the speeds taken from radar tracking data and verified in the simulation, at outer marker and at touchdown. And, again, it's important to emphasize that these are not expected to change when VAS is in operation.

A little bit more about the simulation. Again, it was used to determine procedural implications, controller performance, and controller workload. It's important to note that the air traffic control simulation facility at NAFEC can only duplicate air operations. Ground control is not part of that simulation. Some important statements follow based on that.

This is the facility at NAFEC where four of the air operations, just about everything from center handoff to actual touchdown can be duplicated, even to the point of exercising some inner relationship between arrivals and departures on a runway, but again, ground control, itself, cannot be simulated.

These were the items used to monitor the experiment. When these things showed up, the experiment was going well. When the arrival rates were in the seventy-per-hour range, we knew the system was saturated.

When the VAS green gave increases of three to six operations per hour, we knew that the controllers were using the VAS properly. The increased arrival rate was actually an output of the simulation. The reason we haven't emphasized that is because of the point we just mentioned. Since the all important ground control was not part of that simulation, we prefer that no inferences be drawn that these increased rates will, necessarily, be achieved at Chicago O'Hare. They may be.

These are the results of the simulation. If we had to distill all the findings down to one statement, it would simply be that no procedural implications emerged that could possibly deter the implementation of that system at the present time at Chicago O'Hare.

As far as the controllers were concerned, it was business pretty much as usual. As a matter of fact, it was clearly

FINAL APPROACH AIRSPEEDS

1977

OUTER MARKER

170 KNOTS

THRESHOLD

135 KNOTS

RUNWAY CONFIGURATION USAGE

Top Three Arrival Runways

During 1977

• ALL NON VISUAL APPROACH CONDITIONS

- 14R-22R
- 27R-32L
- 14L-14R

• VFR

- 27R-32L
- 14R-22R
- 14L-9R

AD-A077 897

TRANSPORTATION SYSTEMS CENTER CAMBRIDGE MA
FAA/NASA PROCEEDINGS WORKSHOP ON WAKE VORTEX ALLEVIATION AND AV--ETC(U)
OCT 79 W D WOOD

F/G 1/2

UNCLASSIFIED

TSC-FAA-79-77

FAA-RD-79-105

NL

3 OF 4

AD
A077897

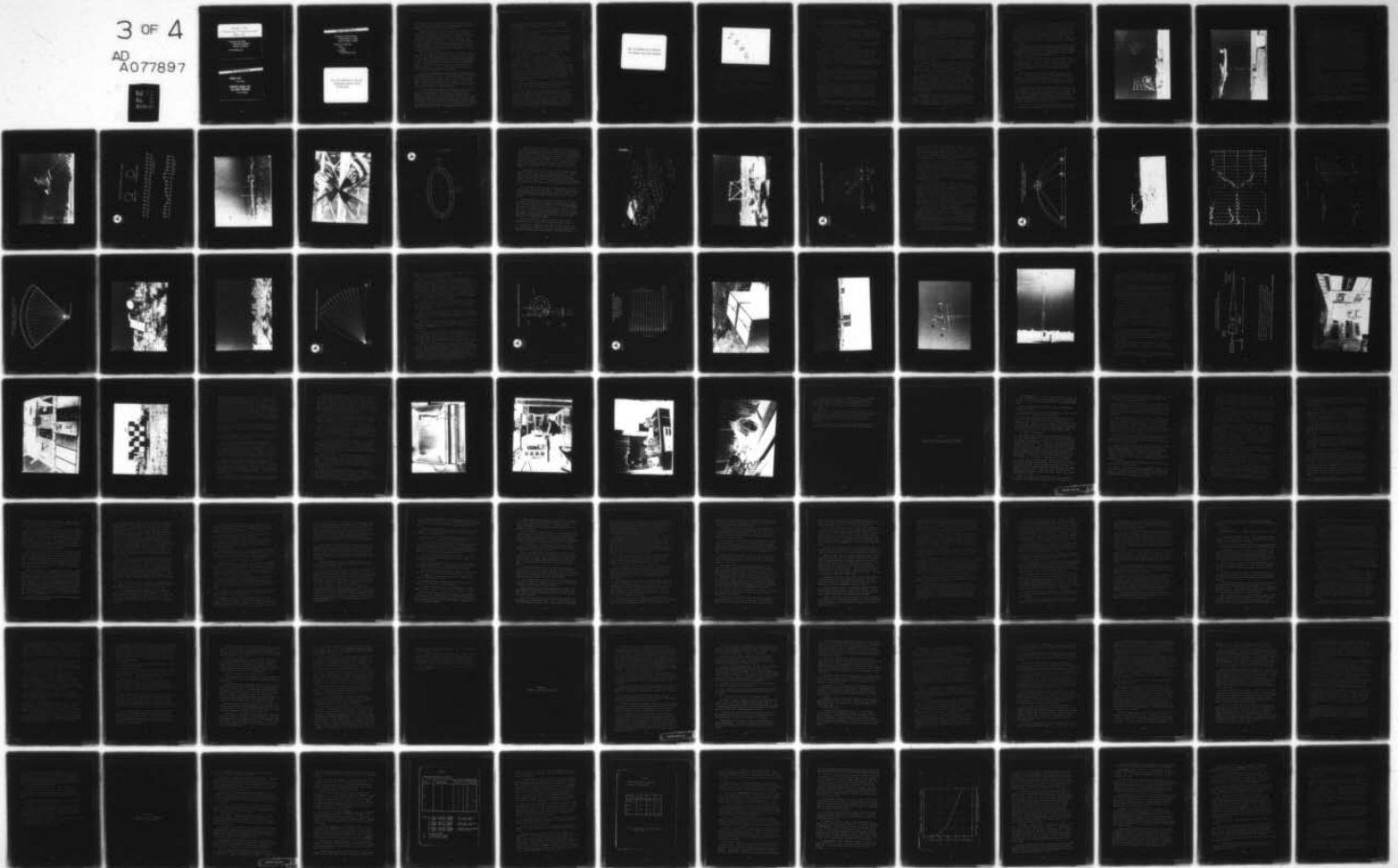

**Simulation of VAS
in Chicago O'Hare Terminal Environment
NAFEC 1977**

- **PROCEDURAL IMPLICATIONS**
 - **CONTROLLER PERFORMANCE**
 - **CONTROLLER WORKLOAD**
- **AIR OPERATIONS ONLY**

ON - LINE MONITORS

- **ARRIVAL RATE**
 - **70 PER HOUR**
- **INCREASED ARRIVAL RATE
(VAS GREEN CONDITION)**
 - **3 TO 6 PER HOUR**

SIMULATION RESULTS....

NO UNFAVORABLE PROCEDURAL IMPLICATIONS

- SEPARATION VIOLATIONS - NO INCREASE
- CONTROLLER WORKLOAD - NO INCREASE

• TRANSITION OF SEPARATION MODES

- ORDERLY
 - 5 MINUTES
- INSTANTANEOUS
 - 1 MISSED APPROACH AT WORST

**WILL THE POTENTIAL OF VAS FOR
INCREASING ARRIVAL RATES
BE REALIZED?**

demonstrated in the simulation that most of the action of VAS is not in the tower along the final approach monitor, but in the TRACON as handled by the arrival controllers.

Separation violations showed no tendency to increase, nor did controller workload. There was a lot of anxiety about a transition of separation modes before the simulation. This addressed the situation where controllers may be using the VAS system on a given set of runways. It says, green; the traffic is closer together, based on that green indication; the system suddenly changes to red. What is involved in that transition of separation modes from the reduced VAS separations to the conventional prescribed minima?

That was looked at two different ways. An orderly transition, assuming that the system had a buffer in it that would give the controller some indication of an in-between zone and then it was exercised with no buffer where the green went instantaneously to red, and the controller was confronted with an instantaneous change -- The way they prefer it, from the indications of the O'Hare controllers -- It was found that an orderly transition could easily be accomplished in five minutes.

As far as the instantaneous transition was concerned, most of the time nothing more had to be done than an orderly transition. The reason for that was shown in one of the previous Vu-graphs, that 78 percent of the traffic already comes in at three miles. Many situations presented themselves. There were very few aircraft, if any at all, at the given time that the change occurred, were really committed to a VAS separation.

The worst that ever happened was one missed approach which was exercised outside the outer marker. Although it didn't happen in the experiment, it's conceivable that two missed approaches would have to be exercised, one on each arrival runway. That would be the absolute maximum condition that could possibly be expected. The simulation served to highlight the fact, though, that quite often an aircraft inside the outer marker was committed to a VAS separation when the system changed from green to red.

These were permitted to land and it's generally felt that the system should be designed and used so that this can actually happen in practice.

Pilots, most of all, find any missed approaches inside the outer marker, most objectionable.

Back to the on-site demonstration. This is the fundamental question that will have to be answered. We've already mentioned that the radar tracking tape data almost does the job for us. What it does not do, though, is tell us if the system is not being used, why not? Are the controllers being conservative with it? Are the pilots rejecting VAS separations? Is there something in the ground control situation that backs up into the air? These are the questions that will have to be answered on site.

Hidden behind this question is another vital one. How seriously will the controllers take the VAS indications in the selection of runways? Will they actually select runways based on VAS green indications? Will they actually make a change of runways? For example, that condition in the transition of separation modes -- If they are acting on a runway that changes to red, will controllers consider a change of runway configuration to take advantage of some green runways that may present themselves? This is going to be a vital question at O'Hare and it's important as to whether that system will rank with the other factors in a runway selection process.

The developers pointed out many times that a vast majority of the time, some runway configuration will be showing a green. The question is, will the controllers get over to it?

I'm not going to point out anything particularly special about that Vu-graph. That's merely arrivals taken from the simulation on parallel fourteens. There's one aircraft in that pack that's committed to a VAS separation. Rather than going into that in detail, the Vu-graph merely acts as a back-drop for what might be the concluding statement, and that is as much as has been learned about the VAS system through analytic study by

**WILL VAS EMERGE AS A FACTOR IN
THE RUNWAY SELECTION PROCESS?**

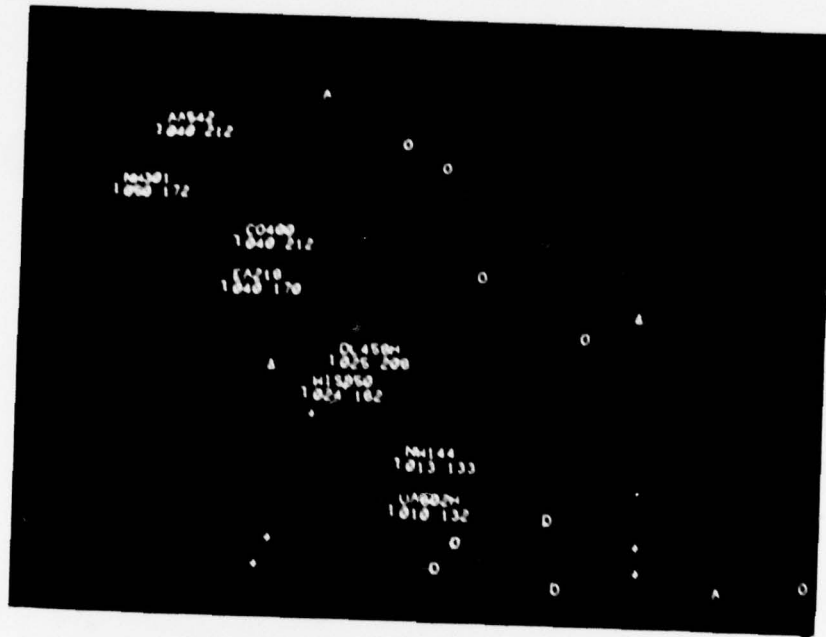

various investigators. Many investigators have determined O'Hare baseline information as we have with some of the NAETC data. The developer has, over a period of a year or two, gotten VAS indication patterns. The system has been tested through simulation. Results appear favorable.

We're at the point where program advances are almost entirely dependent now upon the actual operational demonstration itself, and that's why it's so anxiously awaited this coming year.

Thank you.

MR. TINSLEY: Bill, you've got 19 minutes and 30 seconds to talk about VAS enhancement and future sensor design.

MR. WOOD: Thank you, Guice.

First of all, let me address the subject of enhancement and then I'll take you on-whirlwind tour of the development of sensors, trying to point out some of the things that we've learned about the sensors we've used at the various airports and they cannot be used in an operational environment.

Rather than describing the things that are all positive about the sensors, we'll address why most of them are not adaptable in today's environment to an operational airport.

Considering the enhancement of VAS, you'll remember in the movie where they talked about 65 percent utilization effectiveness. That's the maximum amount of time that you'll get to use the VAS reduced separation looking at ten years of wind data. That says, that's the amount of time that the wind will be outside the inner ellipse or the green part of the diagram, the green outer part of the diagram, such that we can bring the airplanes in at three miles.

That's not very much when you stop to think about all the other considerations that have to be taken into account in bringing the aircraft in. Therefore, what we're trying to do is find out if there are other things relative to the VAS, which we have not considered yet, which can be implemented to increase its effectiveness.

If you'll recall in the movie, we talked about only the transport of the vortex due to wind. We've not considered any other element in that algorithm or in the system. We've seen in data from J.F.K., where we did a lot of measurements for several years, that there are things like turbulence that drastically affect the vortex while the algorithm would tell you it's a red condition.

The vortex is dying rapidly. It's breaking up. It's not persisting in that corridor which would be of concern to us, but

we don't take that into consideration. We do not consider any decay of the vortex. We take into consideration only the transport. Therefore, if we take a simple measurement of turbulence, with a third axis anemometer, we can factor that decay consideration into the algorithm, take the amount of time that the system would then be green with turbulence consideration, and raise the effectiveness up to about 80 to 85 percent -- A fairly significant increase for an addition of one simple sensor.

We measured this phenomenon with a device called a pyranograph at J.F.K. which looks strictly at cloud cover. During the time that you are getting normal heating of the atmosphere and subsequent heating turbulence, we found that the vortex would disappear rather rapidly. It wasn't being blown out of the corridor. It was being broken up due to the normal atmospheric heating turbulence. Therefore, we feel that we have a very good possibility of incorporating some of those types of measurements into the system, thus gaining effectivity.

We also want to look at what can be done to predict to the controller when conditions are changing to red so that he can take steps to move the aircraft around and not get into the missed approach situation. That's one of the biggest criticisms we've had so far, and it's one of the things that Hector addressed.

If Chicago spaces its aircraft on final approach anywhere from sixteen to forty miles out, you don't want to be pulling aircraft out on missed approaches inside the outer marker. Therefore, we'd like to find out if there are other ways that we can predict when that system is going to change to red, so that we can pull the aircraft out, space them properly back to the 3,4,5 and 6 miles and keep the operation normal without going into the missed approach mode.

Those are the two primary things that we're looking at as far as VAS enhancement. When we talk about VAS, I want to re-emphasize that it is strictly advisory. It does not detect and track a vortex in any way, shape or form and it only tells the controller when he can reduce separations, nothing else.

It doesn't tell him positively the other side of the picture as to whether the corridor is positively clear. He deduces that. It tells him only when he can go to three miles. The sensors that I'm going to talk about now are ones that we've looked at during the development stages of the program. We've looked at detection and tracking, trying to learn more about vortex behavior, the dynamics of vortices, and how these parameters might be applied to the WAS, which would take into consideration detection, tracking and prediction.

Sensors could give positive identification of where the vortex is in the terminal area, positive input to the pilot about whether he's going to see it or miss it, and some positive means of telling whether he's got to make a missed approach and get out of there, or whether it's safe at the last instant.

We're not sure that we know how to use those parameters in a system yet; we are not sure we can get a sensor that will meet the system requirements. We've come close. We know several of them are fairly adaptable to the environment, but we've got other things to do with them. I'll try to go through those rather rapidly.

First of all, if you look back a number of years, to the first part of the movie, you saw some photographic techniques. Actually, these were done at NAFEC in the very early days of the program. The smoke tower in Figure 1 was used to get a visualization of where the vortex was. We had no other means of finding it.

On the ground down there in Figure 2, hardly-visible, there are a couple of sensors which I'll talk about a little later. One being an acoustic sensor, which is the one in the foreground. The little signs with numbers were put there so we could correlate with photographs where the vortex was relative to the sensors. Therefore, we could look at a positive identification of a vortex position relative to what the sensor told us.

Those were the very earliest sensing techniques that we used. The pulsed acoustic sensor was able to give us, very much like a



4-64

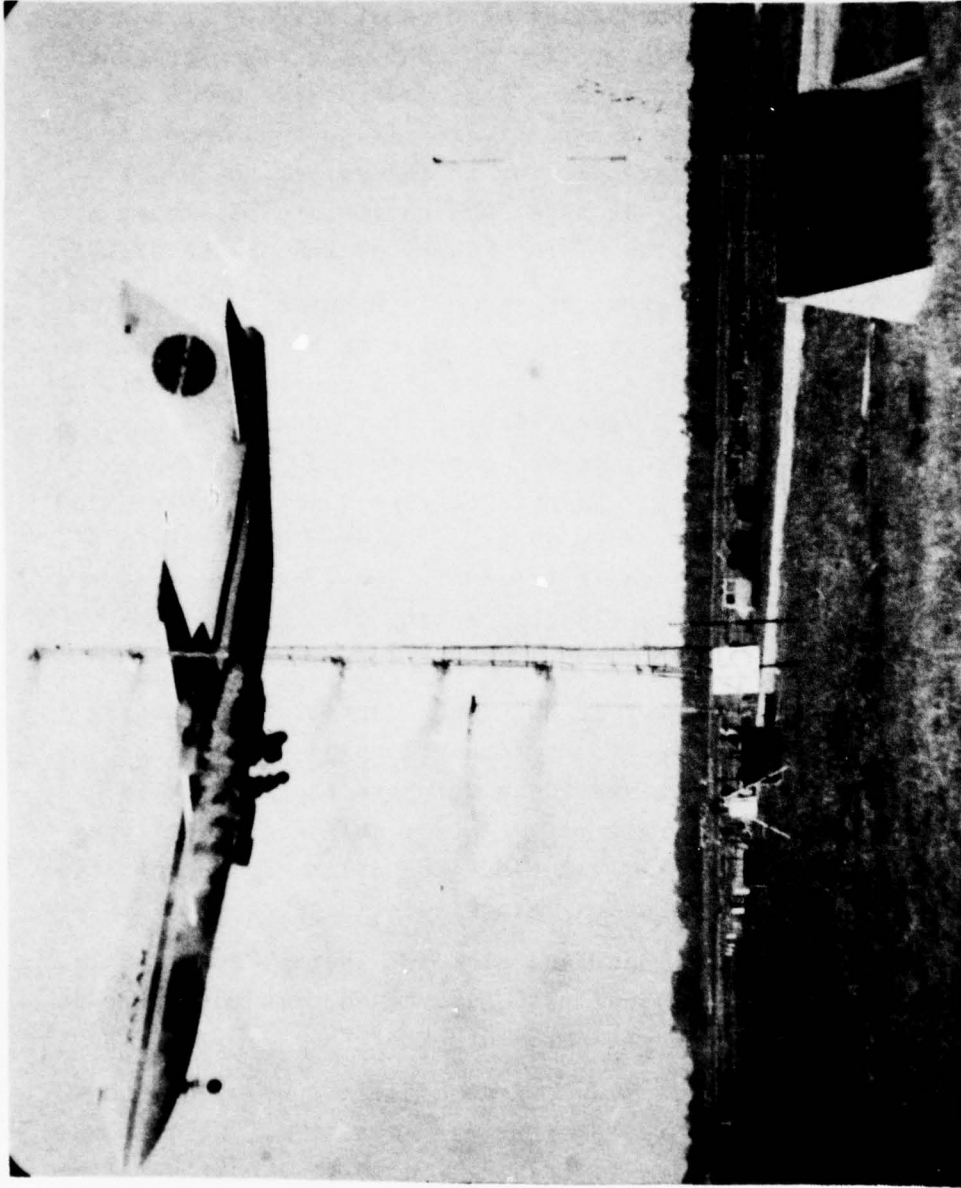

4-65

radar, the altitude and lateral position of the vortex.

The smoke technique you see in Figure 2 naturally cannot be used at an airport because of pollution problems.

Figure 3 shows the combination we used at NAFEC. It had simple anemometers, which we still use today, the sign for photographic techniques, and the wooden frame work device which was a pulsed acoustic transmitter and receiver. It sent an acoustic signal into the reflector and back up to the vortex and as it impinged on the vortex, it was bent back to the ground; there a receiver on the opposite side of the runway picked up the signal.

The anemometers in a array as shown in Figures 4 and 5 give an indication of vortex position by a simple technique. There's the ambient wind level on the anemometer as a constant signal. We get an indication of a vortex crossing that anemometer and consequently the opposite vortex on the opposite side as shown by the positive and negative signal change. Through a very simple fixed axis anemometer we are therefore able to measure the position of the vortex, but we have to use a large string of anemometers, and you have to do a lot of detection processing with computing devices later.

We found that a computer is not very adaptable to tracking the vortex signals simply. It's a rather complex processing scheme to positively detect and identify where that vortex is without any false alarms. There's a lot of noise in those types of systems using anemometers, and there are a lot of discrepancies when you try to computer process that kind of data.

It's very easy to sit back and pick out where the vortex is when the data is run out visually so an eye can pick out where it is. It's not a simple process for a computer.

Figure 6 illustrates a simple reason for not using anemometers. That's one of the Gill anemometers down at J.F.K. In conditions of very light winds, it gradually came to a halt with the ice on it.

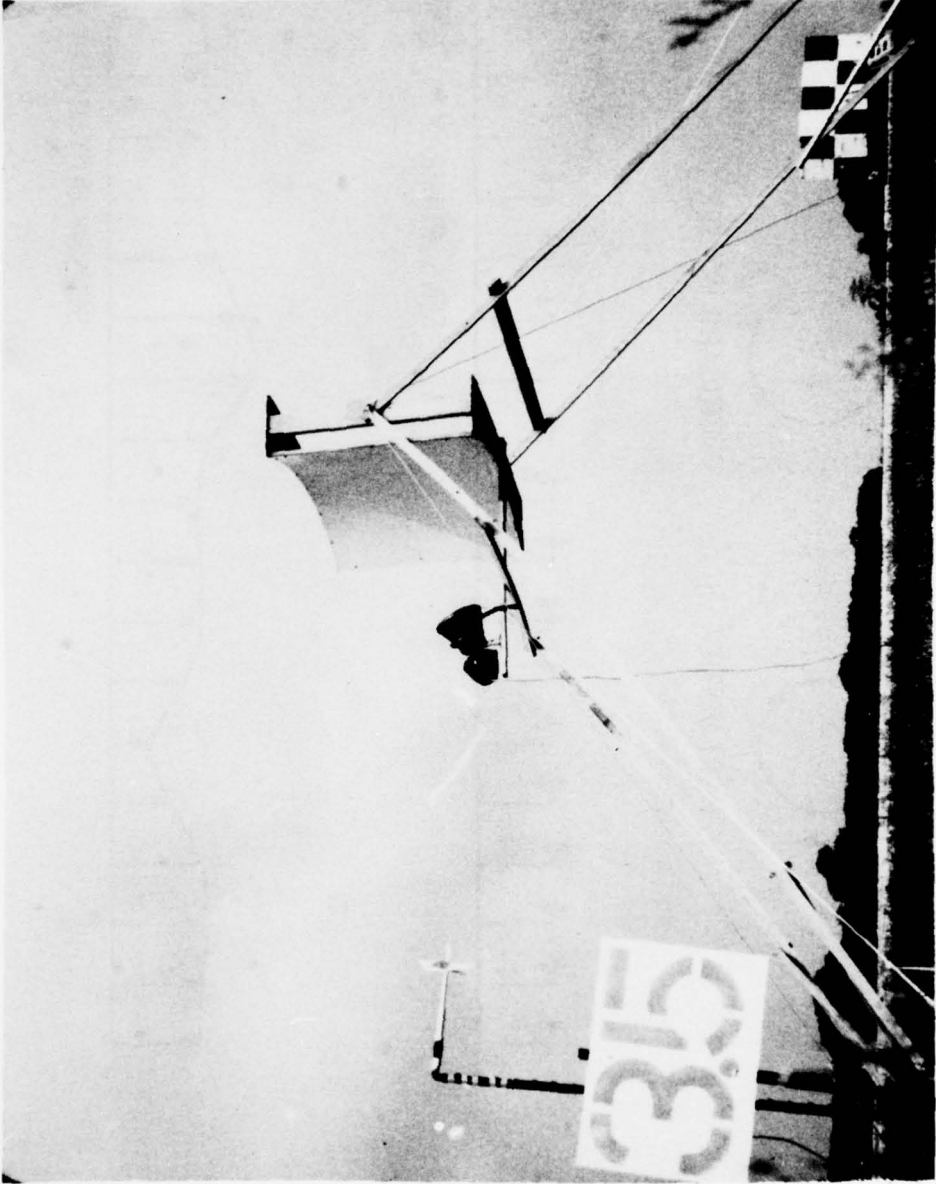

4-67



GROUND WIND VORTEX SENSING SYSTEM



PORT VORTEX



STARBOARD VORTEX



SENSOR ARRAY

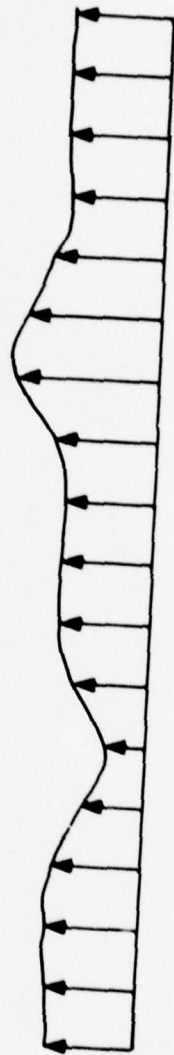

SENSOR OUTPUTS

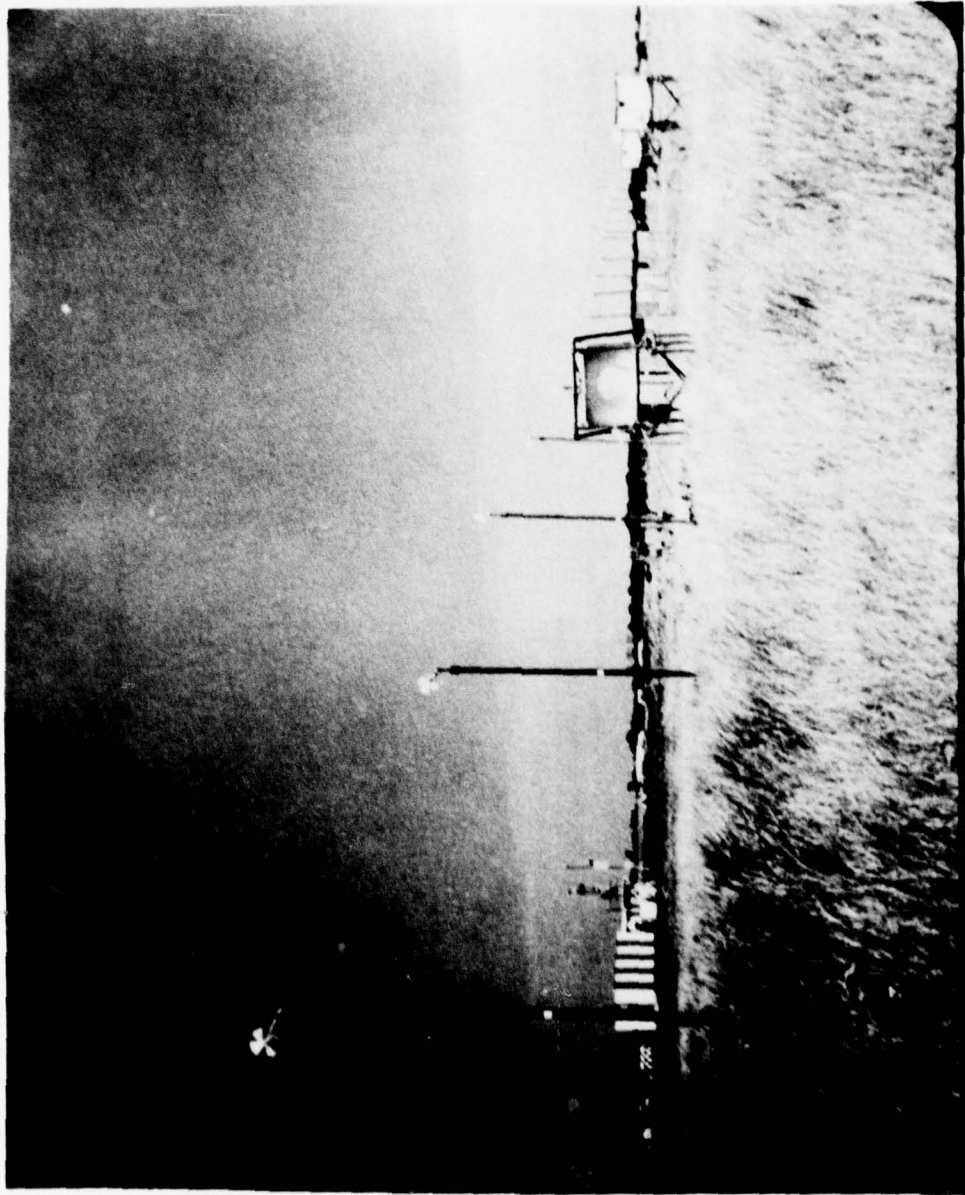

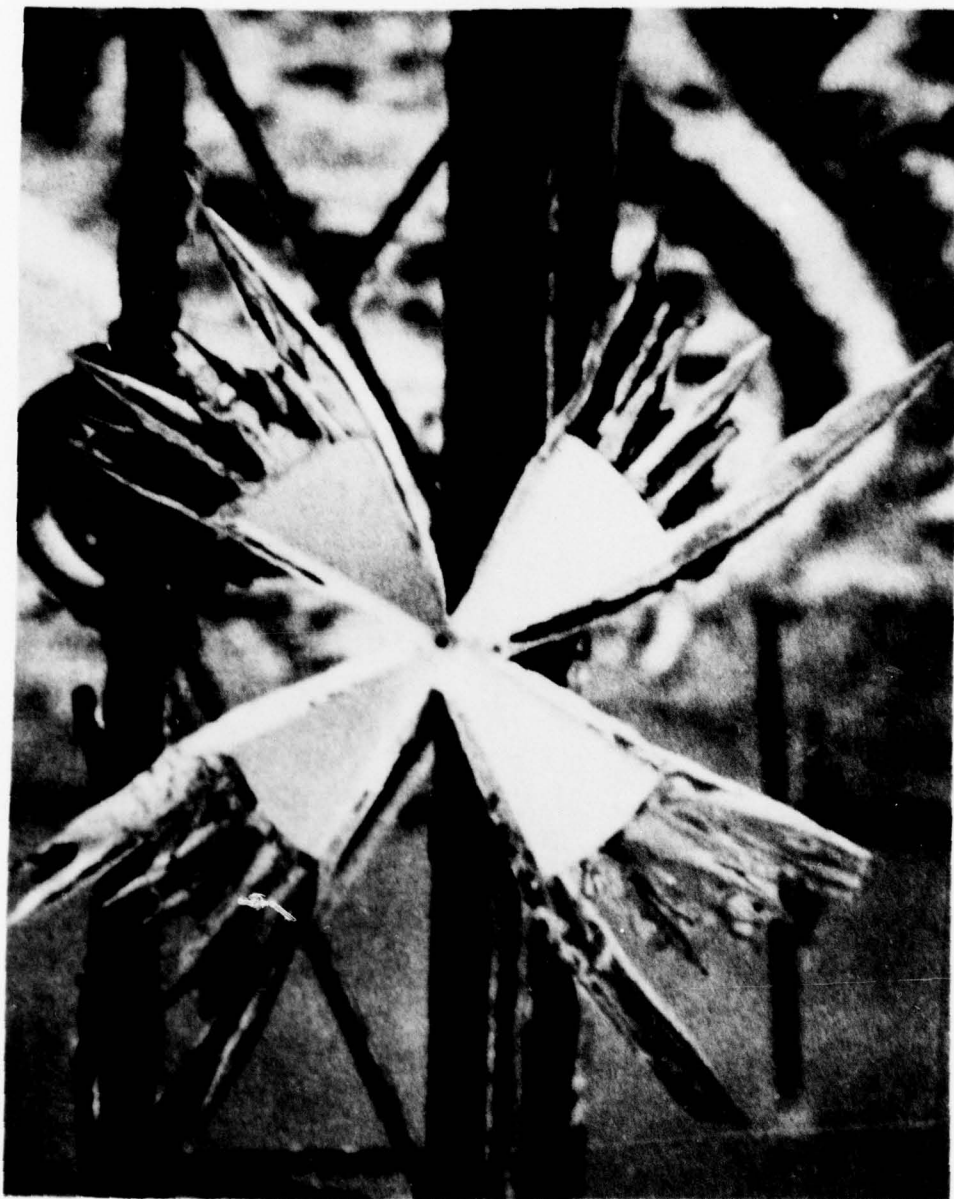

4-70



VAS ALGORITHM

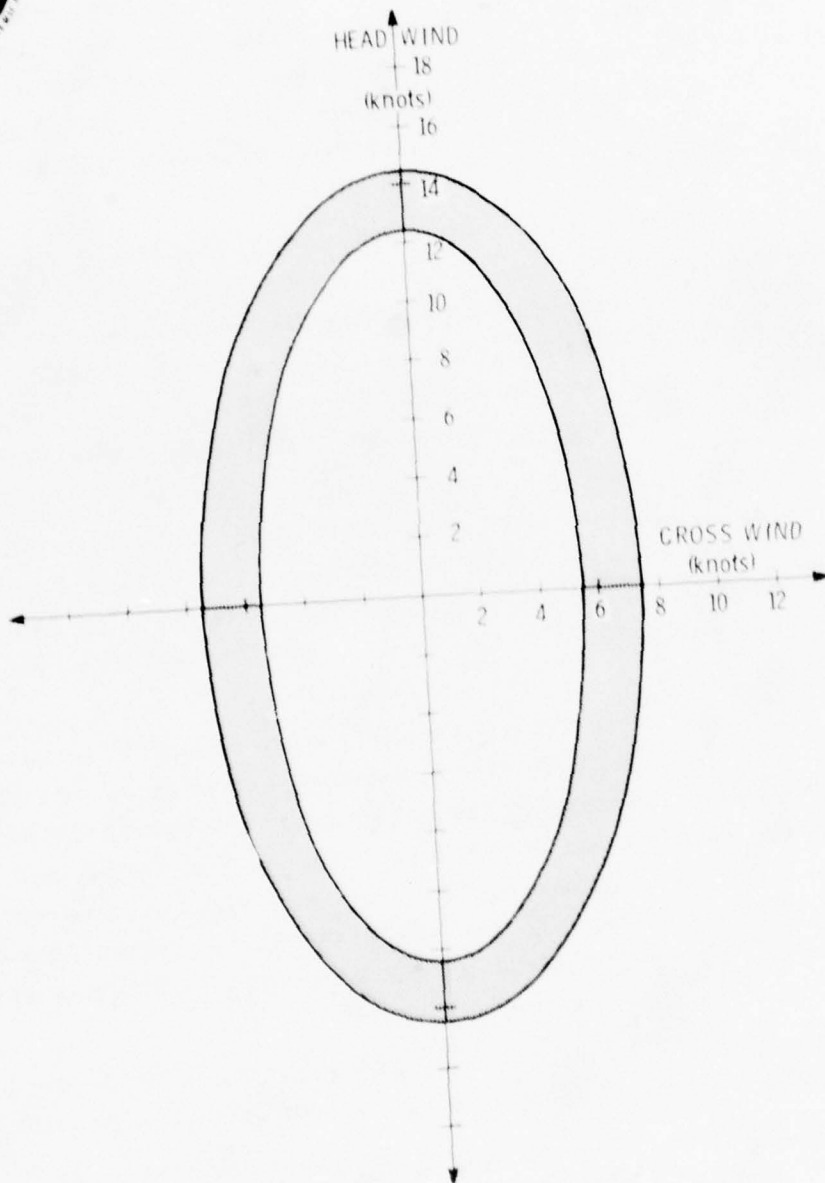

Figures 5 and 8 are of J.F.K. You'll see the complexity of the system in Figure 8. Every sensor that we've tried is shown in Figure 8 including the pulsed acoustic system (PAVSS), the ground wind anemometers of which there are several lines, and these little devices back here which Jim talked about earlier, as being the mono-static acoustic sensors (MAVSS). They look vertically in a narrow beam up into the vortex, but again, the vortex must be moving across that path in order for this sensor to be of any value.

The pulsed acoustic sensor shown in Figures 9 and 10 suffer from the problem of the acoustic signal going up into a tightly wound vortex and coming back in the proper position in the opposite side. However, when you get a loosely formed vortex, such as you might see in a 707, the signal goes up into the vortex all right, but it comes down a long way beyond where the receiver is.

We have problems when we look at different types of vortices with the same type of acoustic sensors. The pulsed acoustic system was dropped after our experience in London -- We had too much difficulty in trying to process the data for whatever it was worth.

The mono-static types are still very valuable in scientific research to look up into the atmosphere and measure the strength of a vortex at relatively low altitudes. At two to three hundred feet above the ground, we were able to see the vortex and by looking at a series of those devices, we were able to find out where the vortex is relative to the acoustic array, then look up above the sensor and measure the actual velocities aloft and change that over to a strength measurement.

The entire scheme at J.F.K. was built to look at vortex behavior and also to assess these various sensing techniques.

Figure 10 is a schematic of the pulsed acoustic device, and all I'll say here is that you can see the acoustic signal being transmitted up toward the vortex properly and reflected down. If

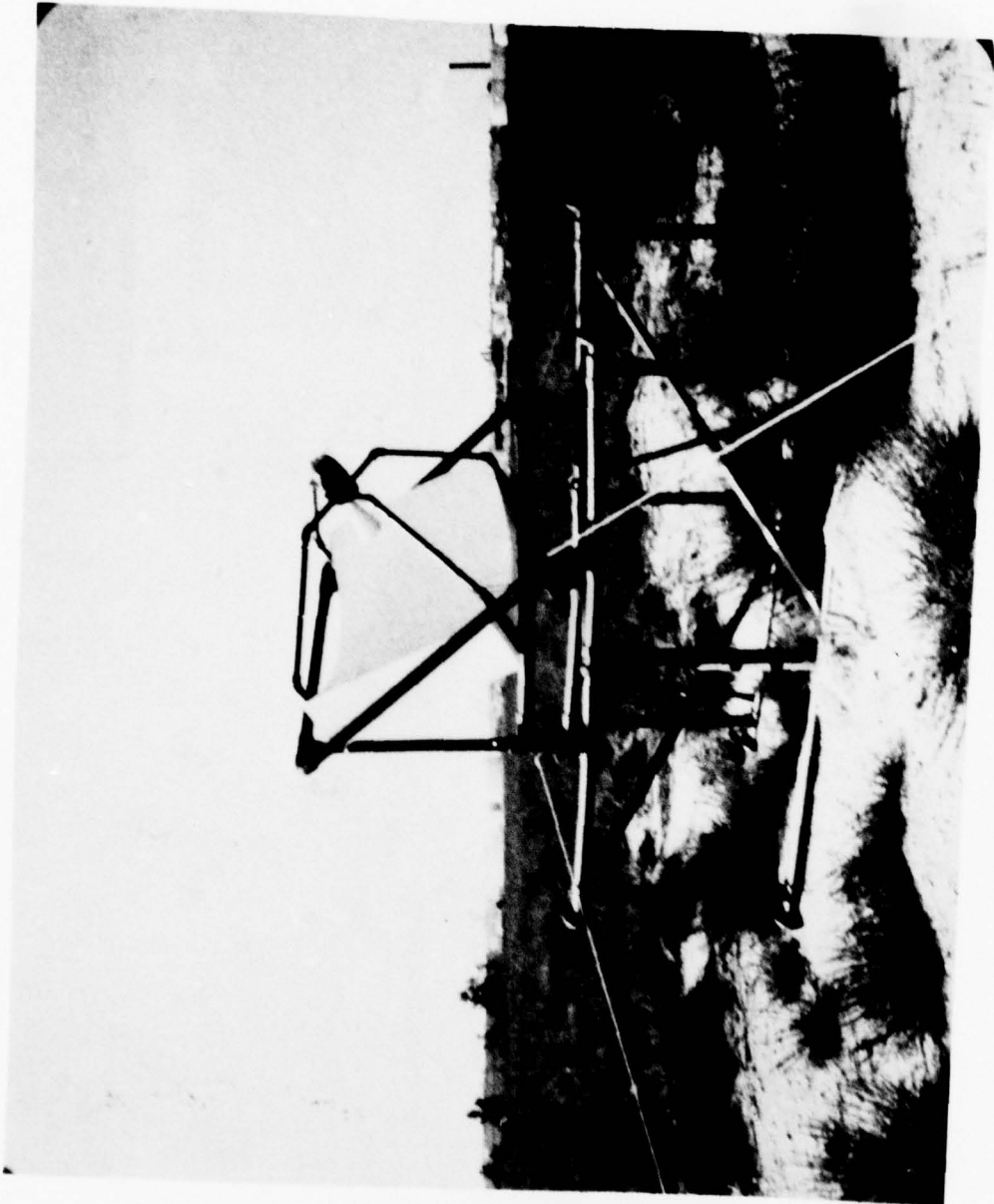

PULSED ACOUSTIC VORTEX SENSING SYSTEM



TSC

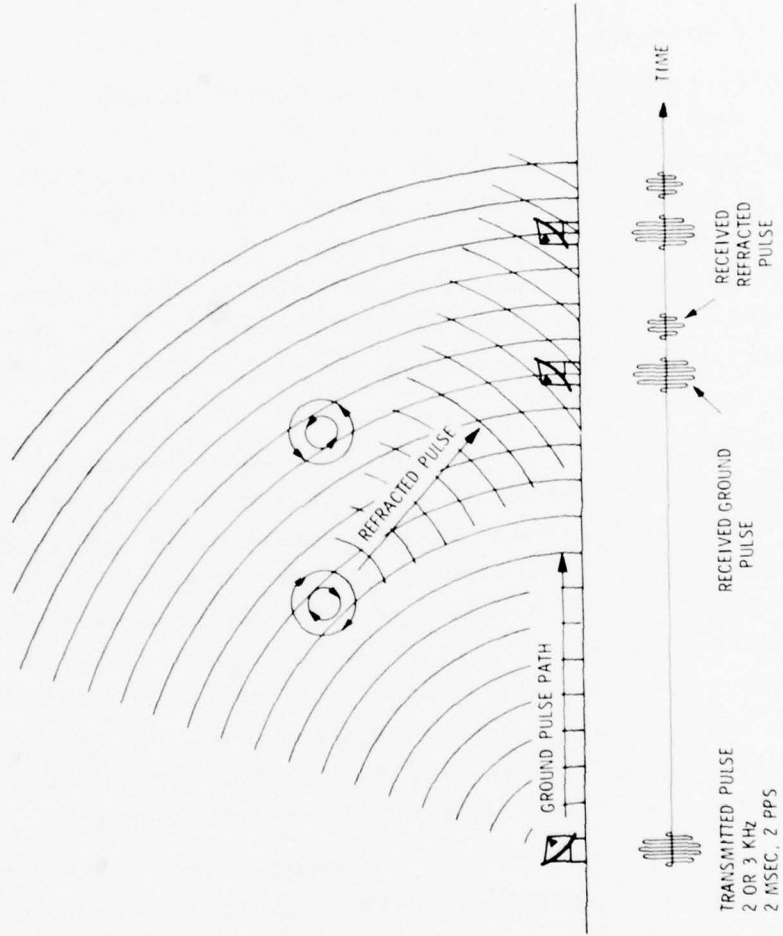

this was a looser-wound vortex, that signal would go up and come down over here instead of hitting these receivers. By using the one transmitter and two receivers, we define a locus of points which are on an ellipse as shown in Figure 11. By using the second one, we get another ellipse, and we can find the inner section of those ellipses and give us a location of the vortex.

Figure 12 is a picture of the pulsed acoustic units, a low mounted one and a high mounted one down at J.F.K., and Figure 13 is a picture of the data that came from an LI011 from the pulsed acoustic sensor. You can see we have the ability to see a vortex going to both sides of the runway as depicted here. It's moving out in the classic manner from both sides, and it came down and went back up in altitude. We were then able, with that data computer processed, to find the vortex location in both altitude and horizontal position.

The next sensor we looked at, shown in Figure 14, was an adaptation of the pulsed acoustic called the Doppler Acoustic, where a CW signal from a single transmitter is fanned up into the atmosphere and the backscatter in narrow beams is looked at with single receivers, some twelve or thirteen of these receivers in an array. Using one element, shown in Figure 15 as a single cone transmitter -- and multi element receivers in a single array -- we were able to look up into the atmosphere. In each cone, as we range-gated them, we were able to find the Doppler shift in each small element vertically above that receiving sensor.

One of the problems with the Doppler type device is that it's very sensitive to background noise. It takes four transmitter/receiver combinations in order to cover the approach zone of the airport as shown in Figures 17 and 18. The beams are so narrow, we have to fan four systems across the airport to cover the approximately three hundred foot corridor that we're interested in. So they're not very practical, plus they suffer from rain noise and moisture problems.

Figure 16 is a schematic representation of the same device where we put a transmitter and receiver on both sides of the



TASC

PULSED ACOUSTIC VORTEX SENSING SYSTEM
VORTEX LOCATION GEOMETRY

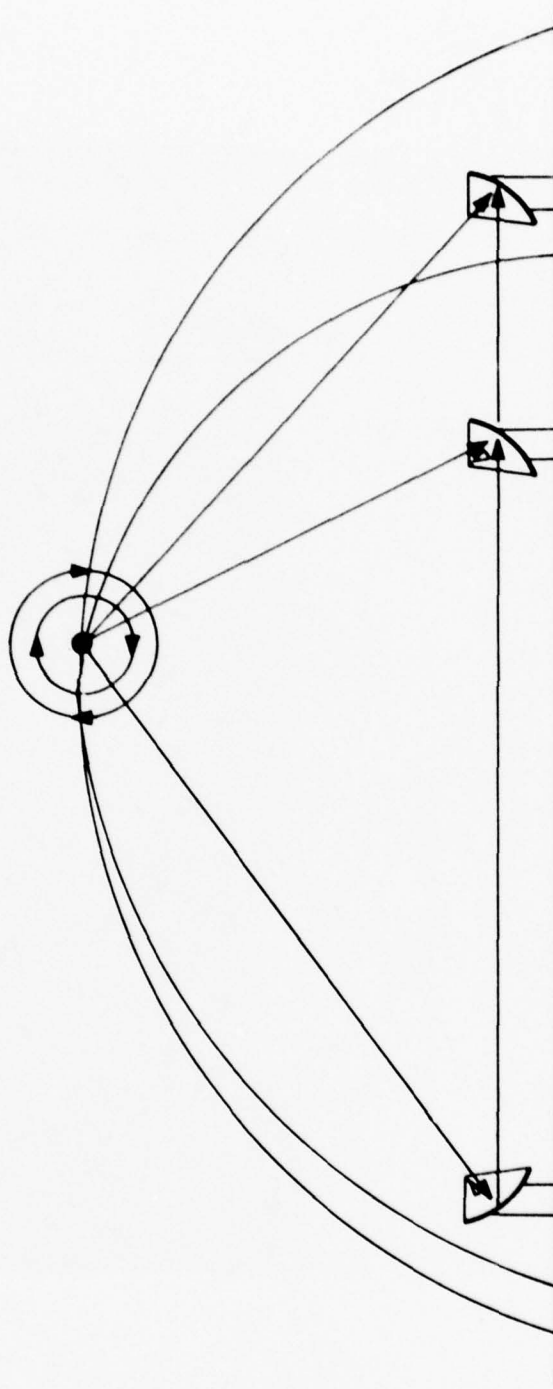



4-1-76

VORTEX LOCATION

200: 40% TYPE K-07 -11 L1011
LEAST SQUARES
H1 VS T

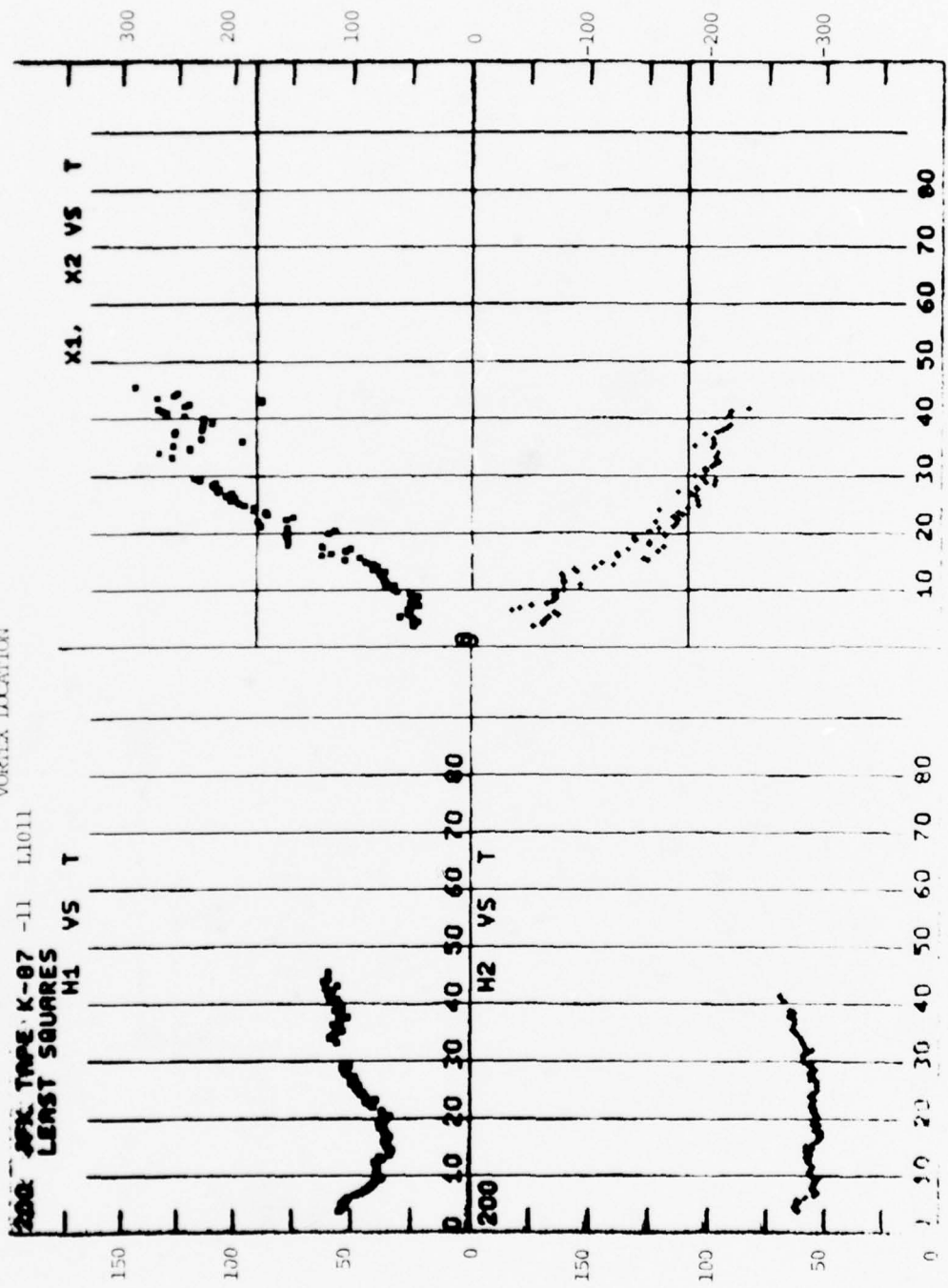

CW ACOUSTIC RADAR

PROVIDES TRACKING CAPABILITY
 $f = 3500-4500\text{HZ}$

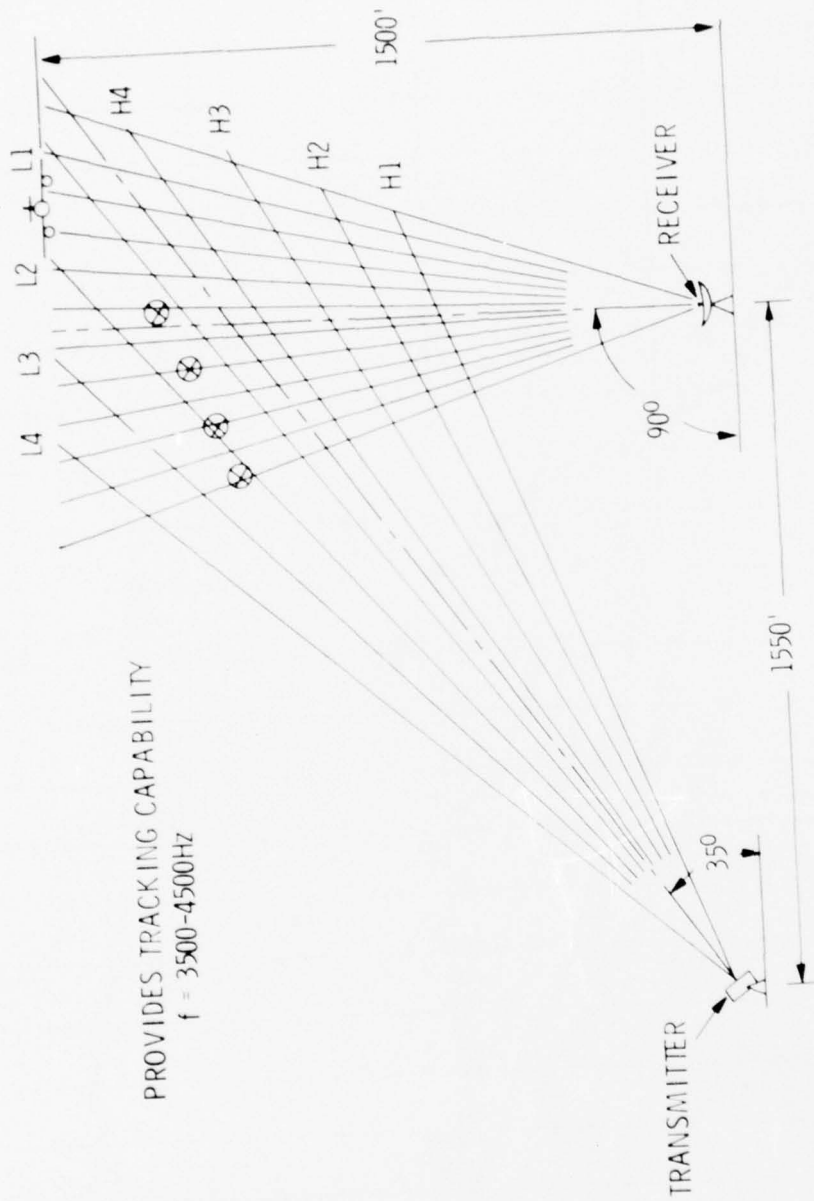

DOPPLER ACOUSTIC VORTEX SENSING SYSTEM
MONOSTATIC CONFIGURATION

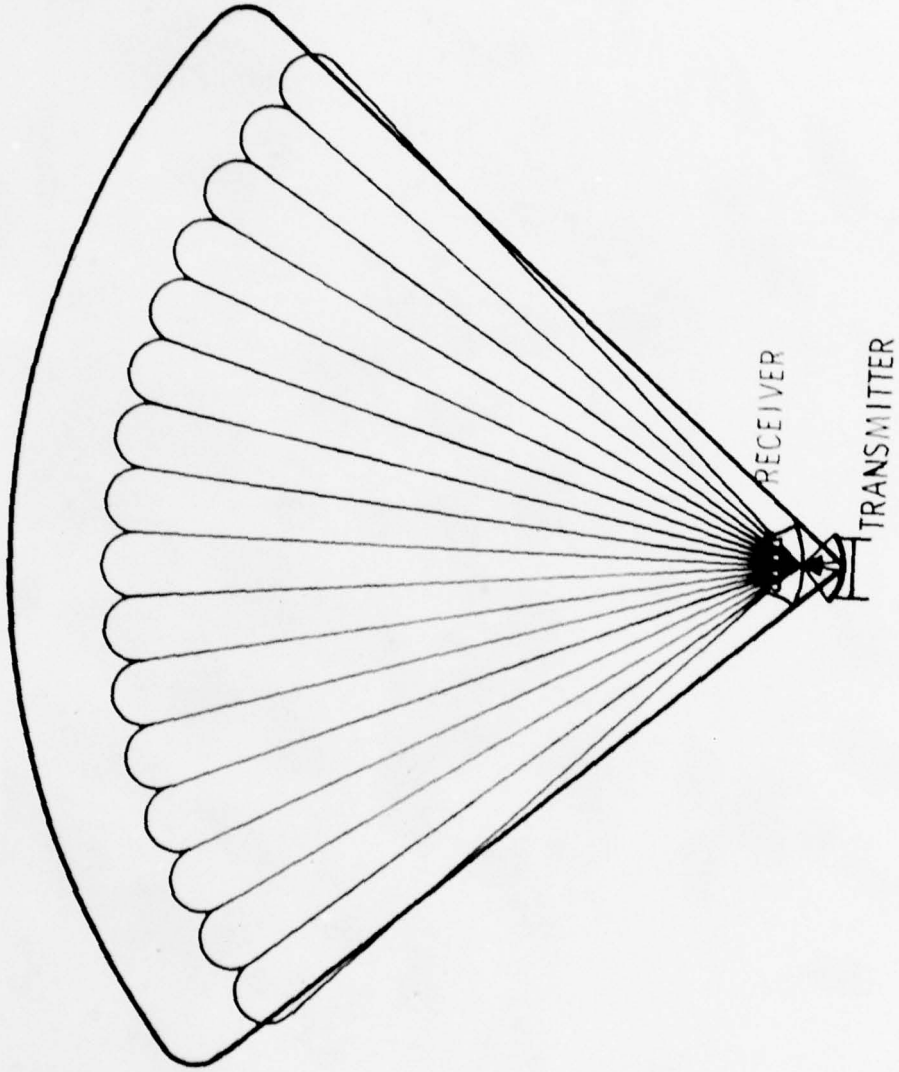

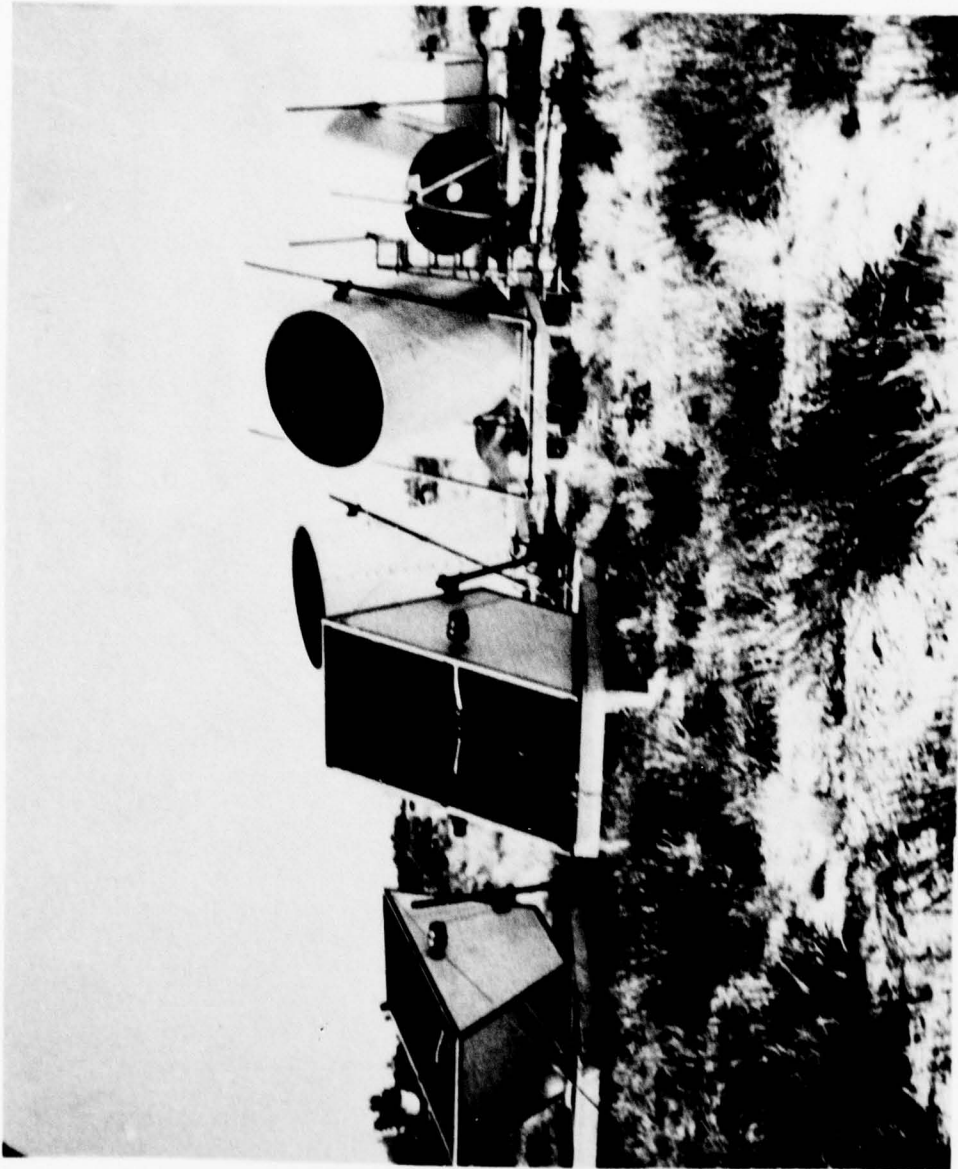



4-83



DOPPLER ACOUSTIC VORTEX SENSING SYSTEM

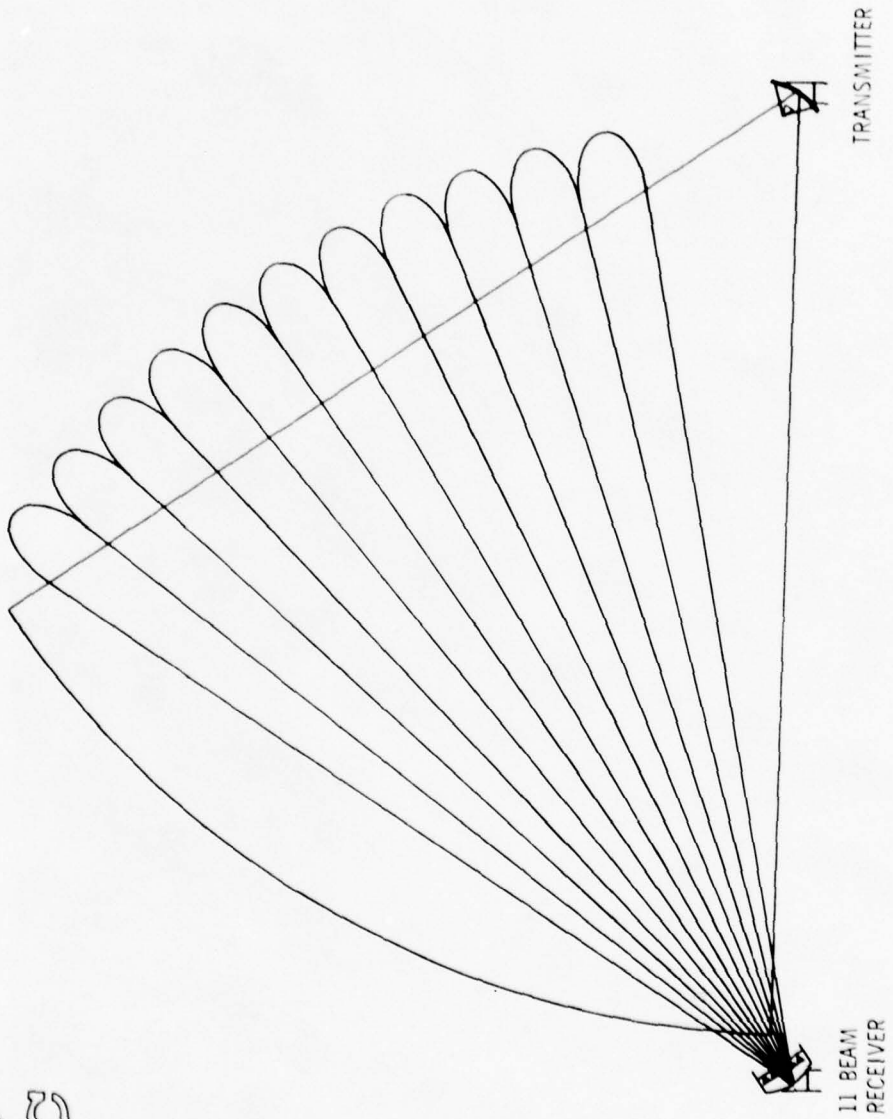

runway and look at the intersecting volumes as shown. It's just another configuration of the same sensor.

Figures 19 to 22 shown the mono-static acoustic sensor. Figure 22 is the sensor that was used out at Rosemond Lake for measuring vortex strength. It's the same one that's currently at O'Hare and that was used at Toronto. It's been very effective in looking up into a very narrow beam and measuring the velocities of the vortex in the beam. The vortex must move over the sensor for it to function. You can't put those boxes in the middle of the runway. Consequently, operationally you have no means of finding where a vortex is when it's over the runway.

If it never comes out of that corridor, out to the side of the runway, and doesn't get over one of those sensors, you don't have any idea where it is or how strong it is. Similar problem with the anemometer.

When we later looked at the laser, its ability to scan over on the side and look over the runway has helped us in finding out what happens to vortices in a takeoff situation when we must look over the runway.

Figure 20 is a picture of the data that is received from the mono-static sensor. Figure 22 shows the mono-static sensor installed at Rosamond Lake when we did the 747 alleviation test with NASA.

In Figure 21 you see the vortex centered in about the 120-foot altitude. Right in this area. This is the vortex going over that sensor. The rest of this is just ambient noise. You can imagine what kind of problems a computer has trying to pull that signal out of the noise in those different range gates.

Looking again at anemometers, Figures 23 and 24 show the devices that are mounted atop the tower which you saw in the VAS. They are the Bendix Aero Vane sensors, hardened sensors that are able to withstand the environment. We used a Climatronics sensor in the R and D system in Chicago, and found out that vortex impingement on the towers was tearing the cups off the anemometers, plus we were having some electronics problems as well.

MONOSTATIC ACOUSTIC VORTEX SENSING SYSTEM

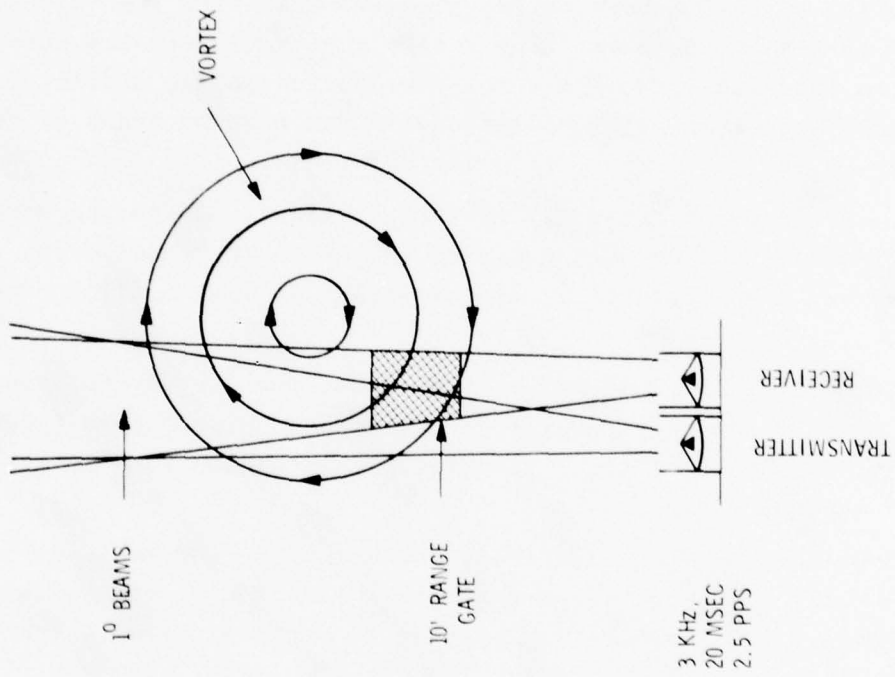

MONOSTATIC ACOUSTIC SENSOR
 DOPPLER ACOUSTOGRAM
 JFK FEB. 19 TAPE K-120
 RUN NO. 12 B-747

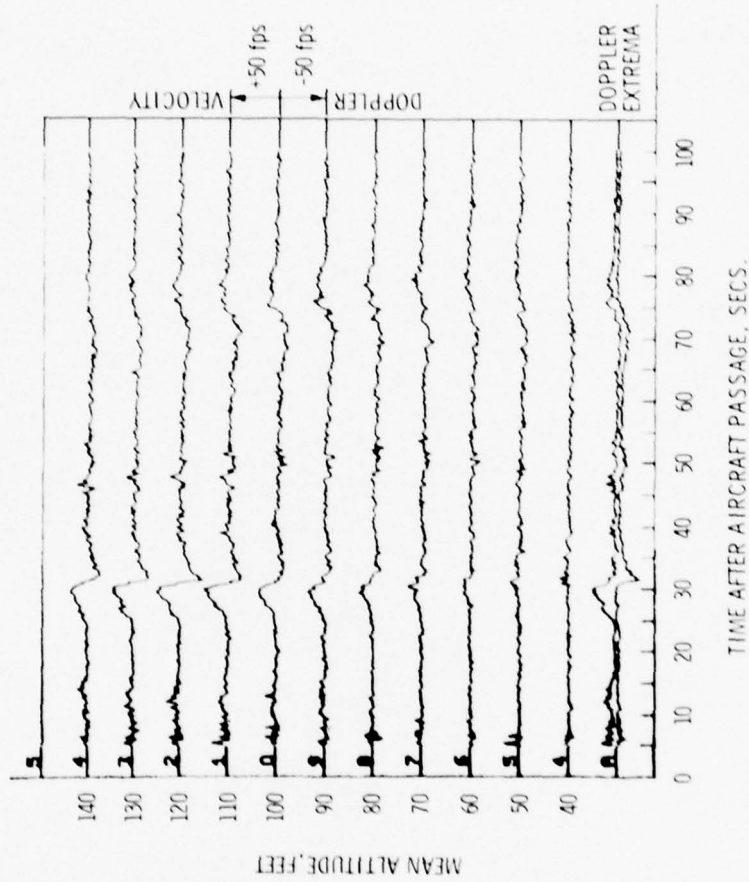

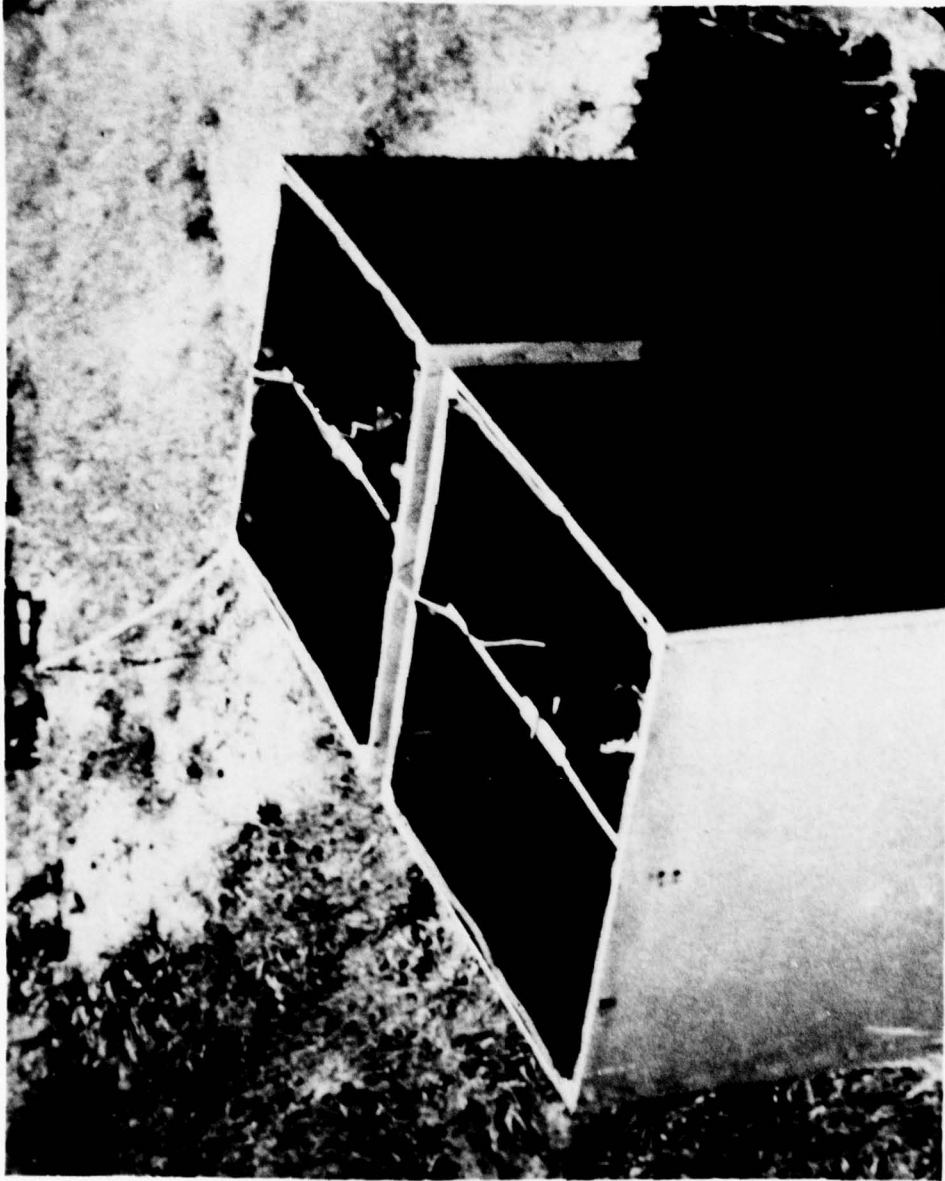

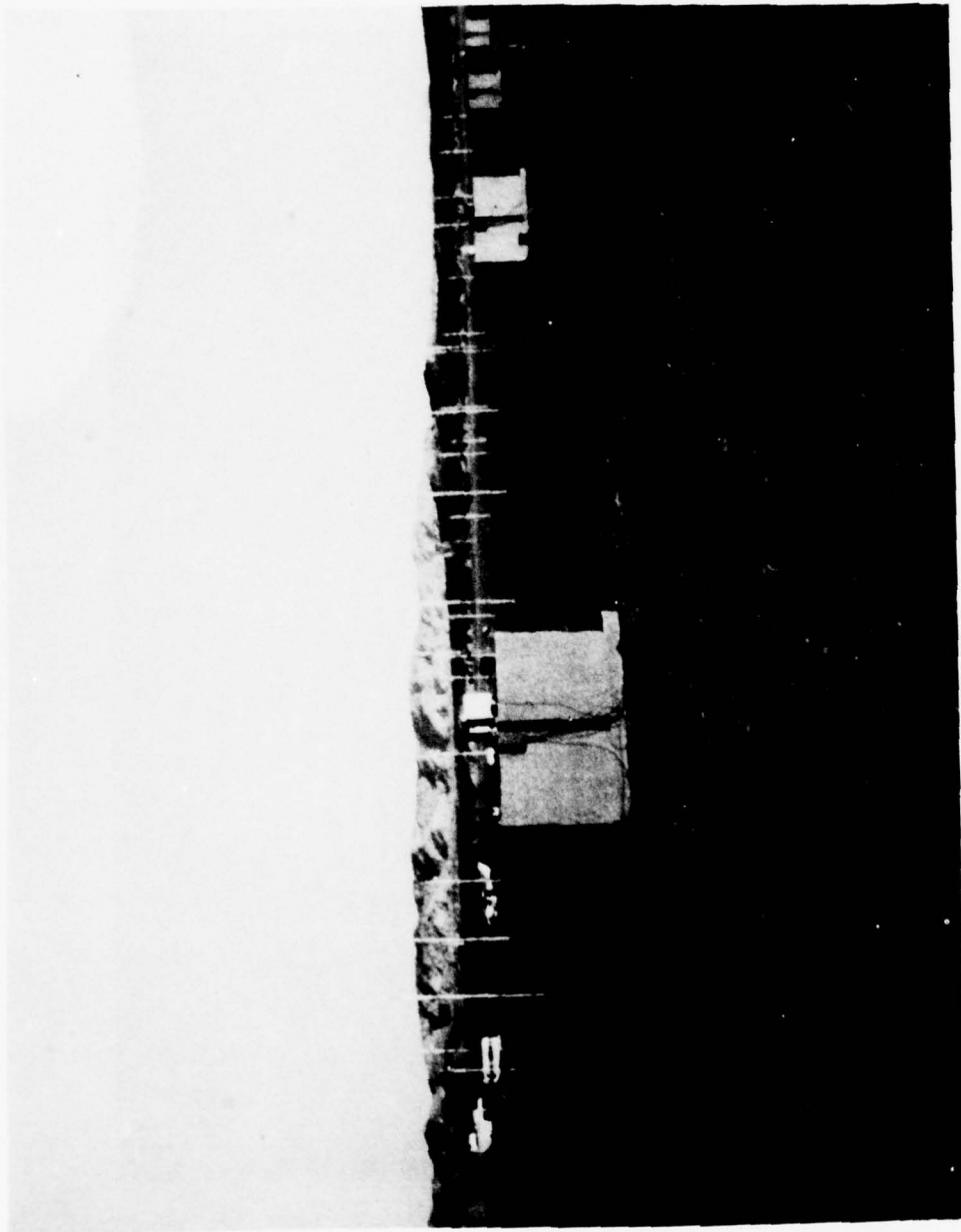

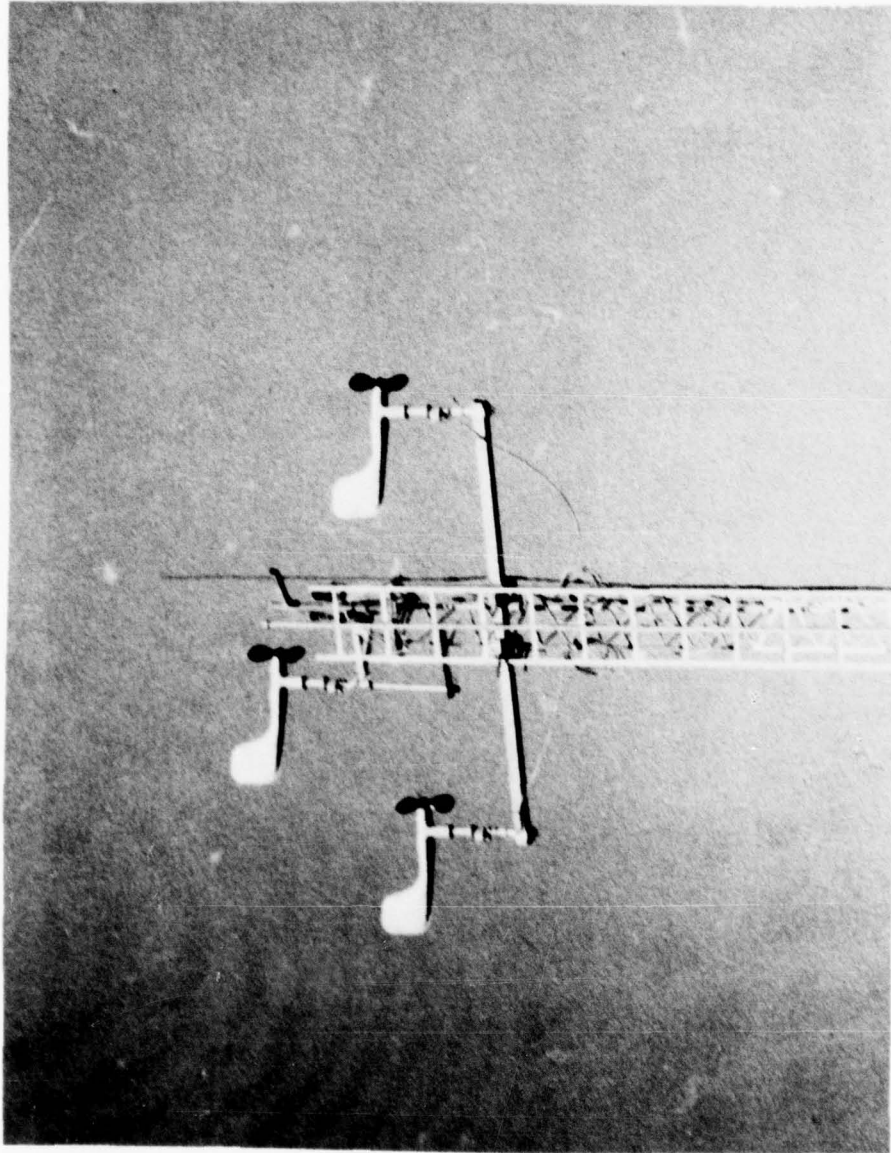

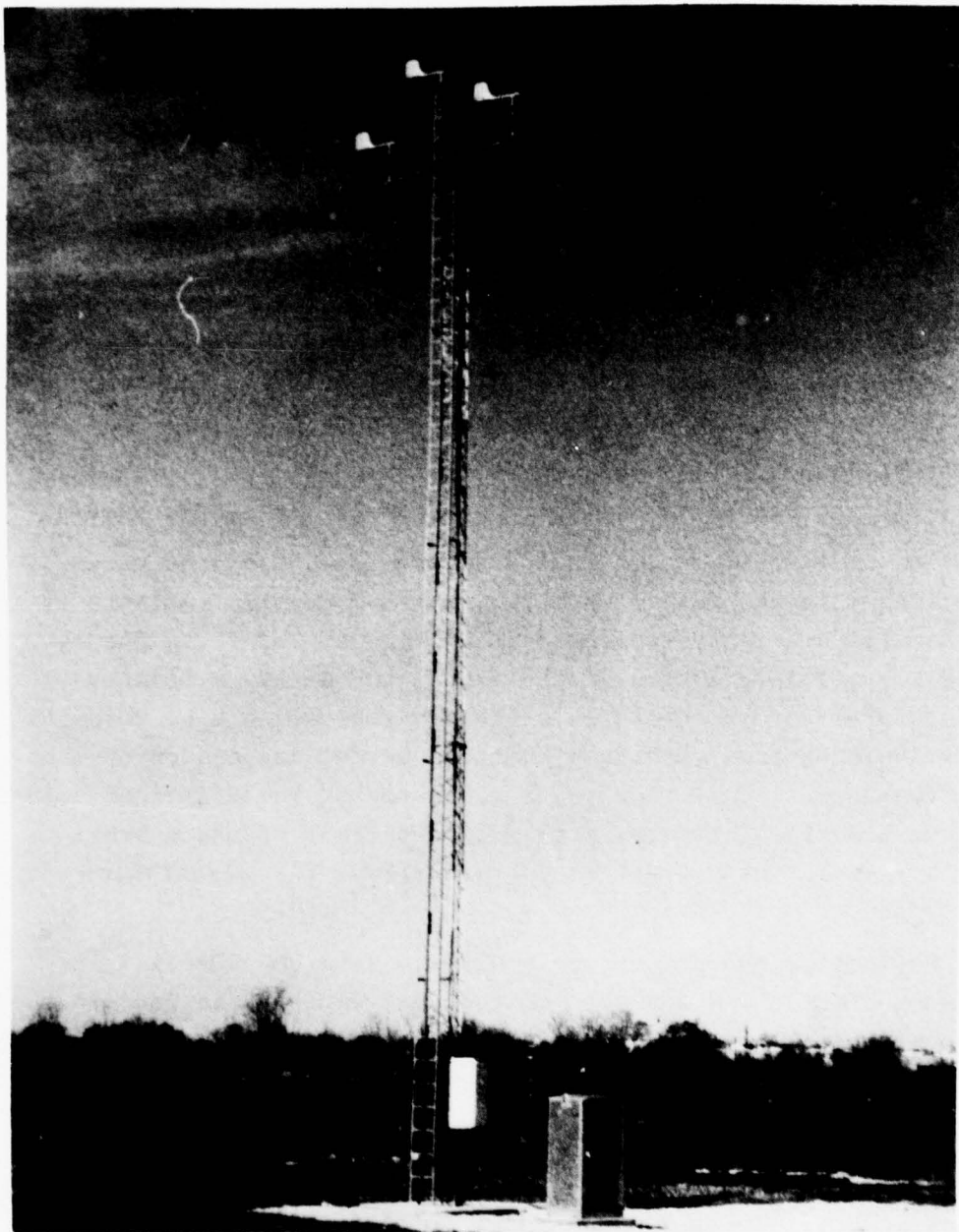

4-91

These devices have been tested in extremes of climatic conditions and are very reliable sensors. The one thing that we find is that if we do have to go to a turbulence measurement, the Bendix sensors are ineffective. We will have to go to some other type device.

The Gill lightweight anemometers, which you saw frozen up, suffer from bearing problems. They will not withstand the atmosphere over a long period of time. Therefore, when we talk about using operational systems, we're faced with devices like this which must be looked at for high reliability electronics and the ability to withstand the atmosphere that we're subjected to.

This includes all kinds of things such as dirt, rain, snow, etc., and the Bendix sensors have performed; the others have not.

The next device which we looked into and have used very effectively is the laser, which you may see outside. Figure 27 is a schematic of the system optics. The laser, itself in Figure 28 is this small device here on the table, and it has a primary-secondary mirror in this area which in turn reflects up through the scanning optics through a hole in the ceiling and on up into the atmosphere. I'll show you a schematic of the different scans that we are able to use, but this is a picture of the system. This is the optics part of it on this side. The electronics on this side.

Basically, the processing equipment is a DEC PDP-11. The scanning electronics are all mounted over in this one console in the center of Figure 29 and Figure 30 shows the computer at one end of the van shown in Figure 31 and the optics are contained at the cab end.

The problem with this device operationally is that it constantly requires two people to maintain it. It has frequent failure problems in the laser, and the optics are very difficult to maintain.

Uniquely enough, we found that in the atmosphere when we were in Chicago last year, that the differential of temperature between

Basic Ways of Determining Range
a. Continuous Wave (CW), Focussed System

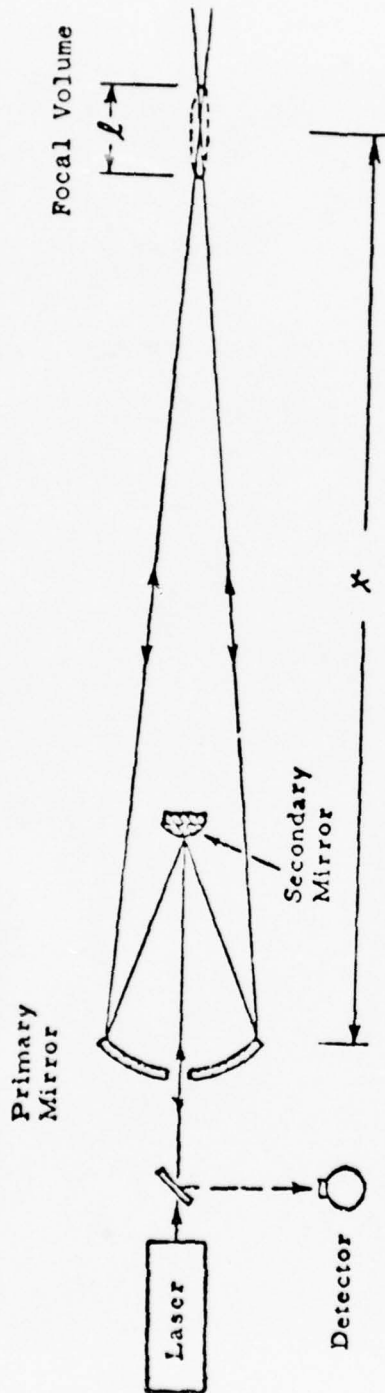

- Range X determined by focussing at the intended location.
- The coherent signal returns come from the focal volume.
- Focal volume length L grows with the square of range X .
- Range limit is set by the required spacial resolution;
 depends on the measuring task at hand.
- Focussed systems are essentially short range systems; $X \leq 0$ (1 km).





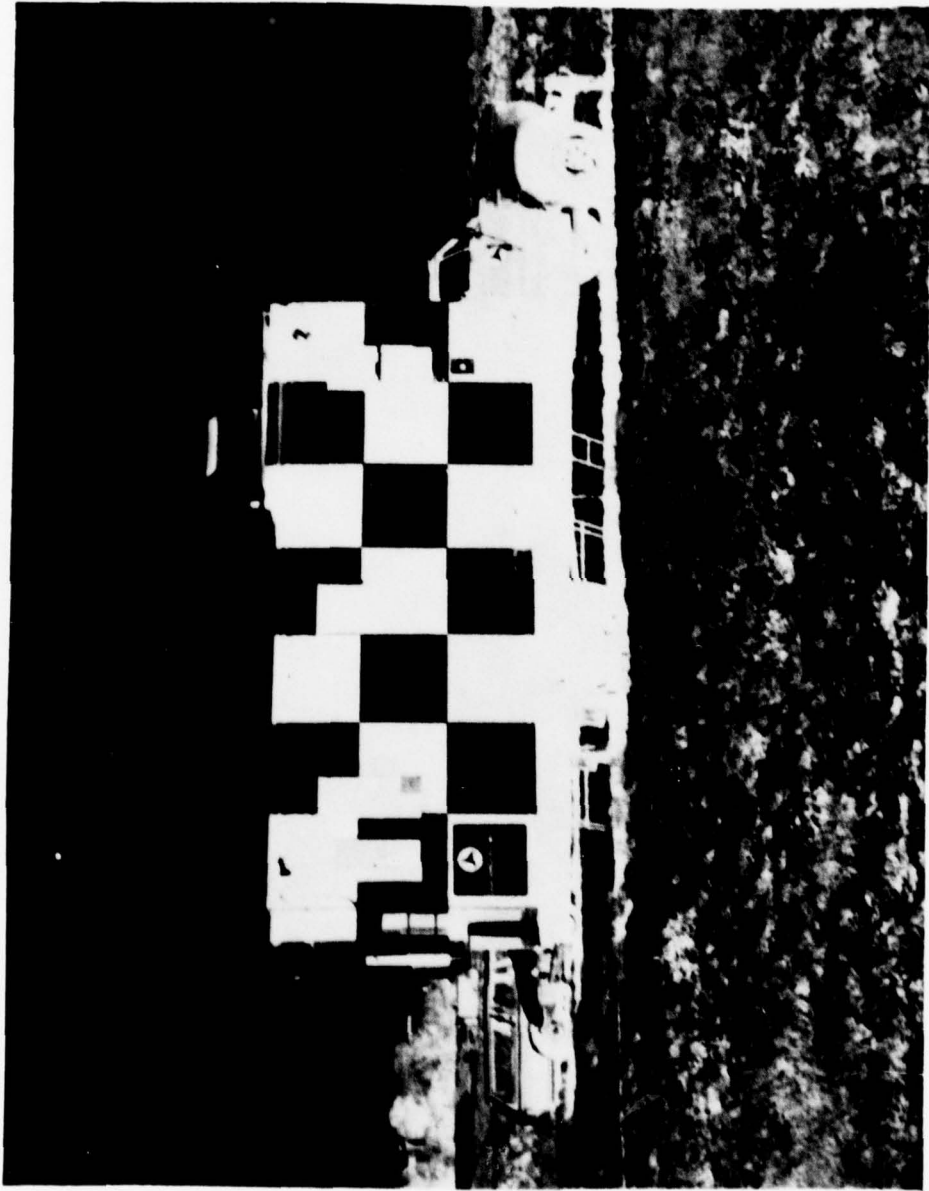

the upper surface and the lower surface of the scanning mirror apparently deflected the mirror enough to cause the range to go significantly out of the realm of reality, and it took us a long while to find out that a few micro-inches of movement in that mirror were enough to cause us to get strange signals returned. The device has been very, very effective in scientific research in looking at vortex behavior. In the atmosphere that we found in Toronto, where vortices descended in over the runway during departure, we were never able to find them coming out of that departure corridor. They never came over the anemometers. We must find out what happened to them.

This is a device that will do it. It will look out over the runway without any kind of obstruction on the runway. We can get to a range of about 2300 feet with that and effectively measure wind or vortices.

This is a CW laser, by the way, not a pulsed one. We've used pulsed laser in looking at wind profiles around an airport and for storms, but not for vortex reasons.

The scan that we used to collect data is what we call a VAD scan, looking aloft for wind profile measurements. If we come over to the side, we're able to look at vortices. One of the problems with this type of device, operationally, is that if you start looking out and find the vortices dropped here, and one is behind the other one, at longer ranges the range resolution becomes so poor that you don't really know what you're looking at.

There's a problem looking through one vortex to another. Once the vortices are overhead, as we saw at Rosamond -- very, very effective. The data that we got there was some of the best we've ever seen. The device was used at O'Hare very effectively, up to about six to nine hundred feet altitude -- very good tracks from it, but, again, not an operational device. It suffers from weather problems.

The device is very, very temperamental as far as operational use, but the device has been effective for scientific research.

Okay, here are a few pictorials of the inside of the van. That's the computer at the end (Figure 30). This is the scanning electronics (Figure 30). That's the computer display inside (Figure 31). Again, the man has to be in the circuit in order to make this thing work. We have to physically locate the vortex by hand. We cannot find it with the computers. We've tried. We've done it many times, and we have not been able yet to get an effective tracking algorithm to follow those signals.

These are pictures of the scanning optics inside (Figures 32 and 33). You can see the size of the mirror that we're talking about, the secondary mirror and the primary mirror. The optics on these are very, very sensitive, and very easy to damage.

Again, inside the van on the left is a large white tank for nitrogen. The detector on this system (Figure 32) has to be hand-filled. A man actually takes a cup of nitrogen every morning and goes out and cools that detector, and it last for a full day -- not very effective for an airport, but the device has been operational as far as our use in research.

Figure 32 looks at the tail-end of the laser. This shows the detector that must be cooled and the optics which actually bend the signal around back to the detector. The laser beam is the square box on the lefthand side with the hole coming through here. The laser beam actually comes out through here and is transmitted back out through those optics.

Well, that's kind of a whirlwind tour through the sensors, but effectively I think we can say that if we had to pick a sensor today -- an operational sensor -- we'd lean toward wind sensors. Neither laser nor acoustics have proved economically practical. They haven't proved technically feasible from our standpoint for an operational sensor.

We feel that the anemometer has promise. We haven't yet learned how to measure strength with an anemometer, although we feel it's possible. We haven't yet learned how to monitor a track with an anemometer and get positive identification of a vortex and not be fooled by noise and other ambient turbulence.

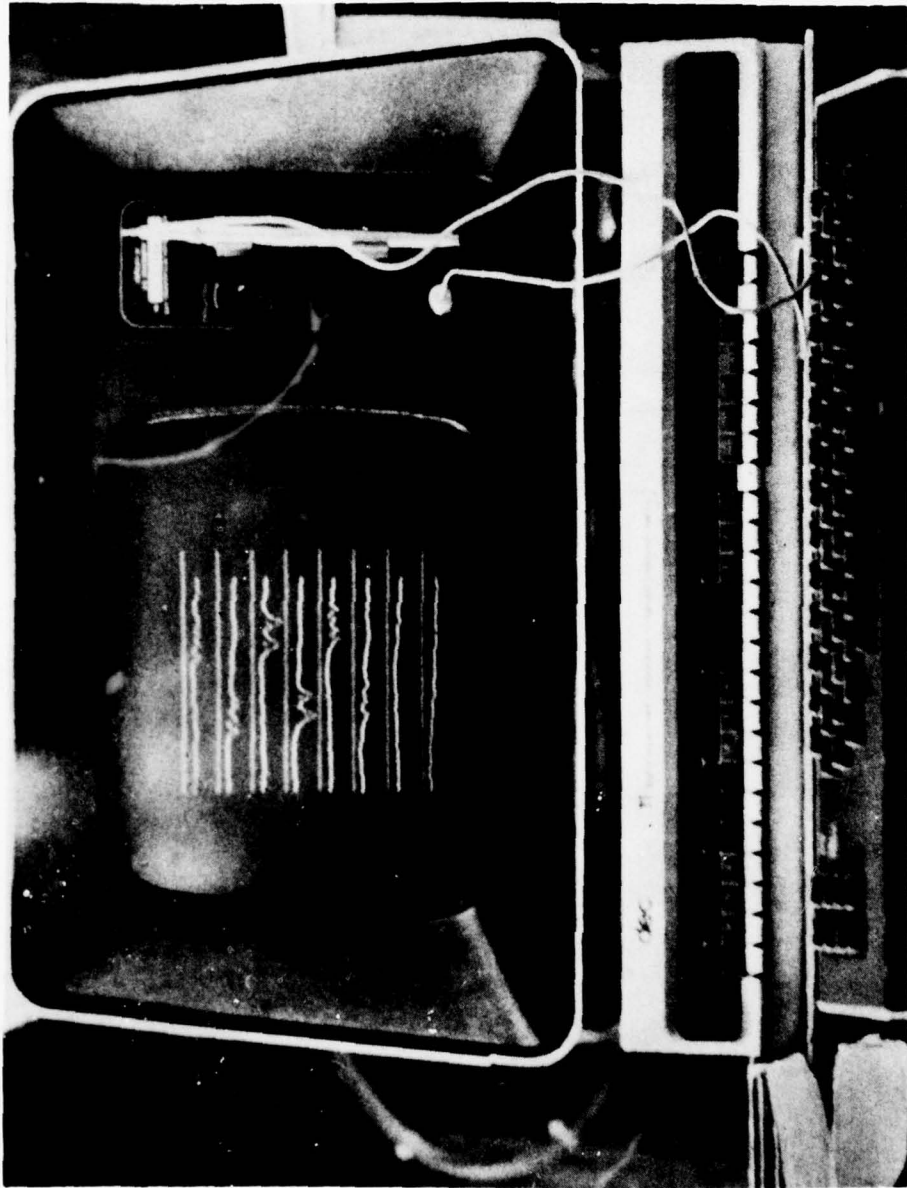

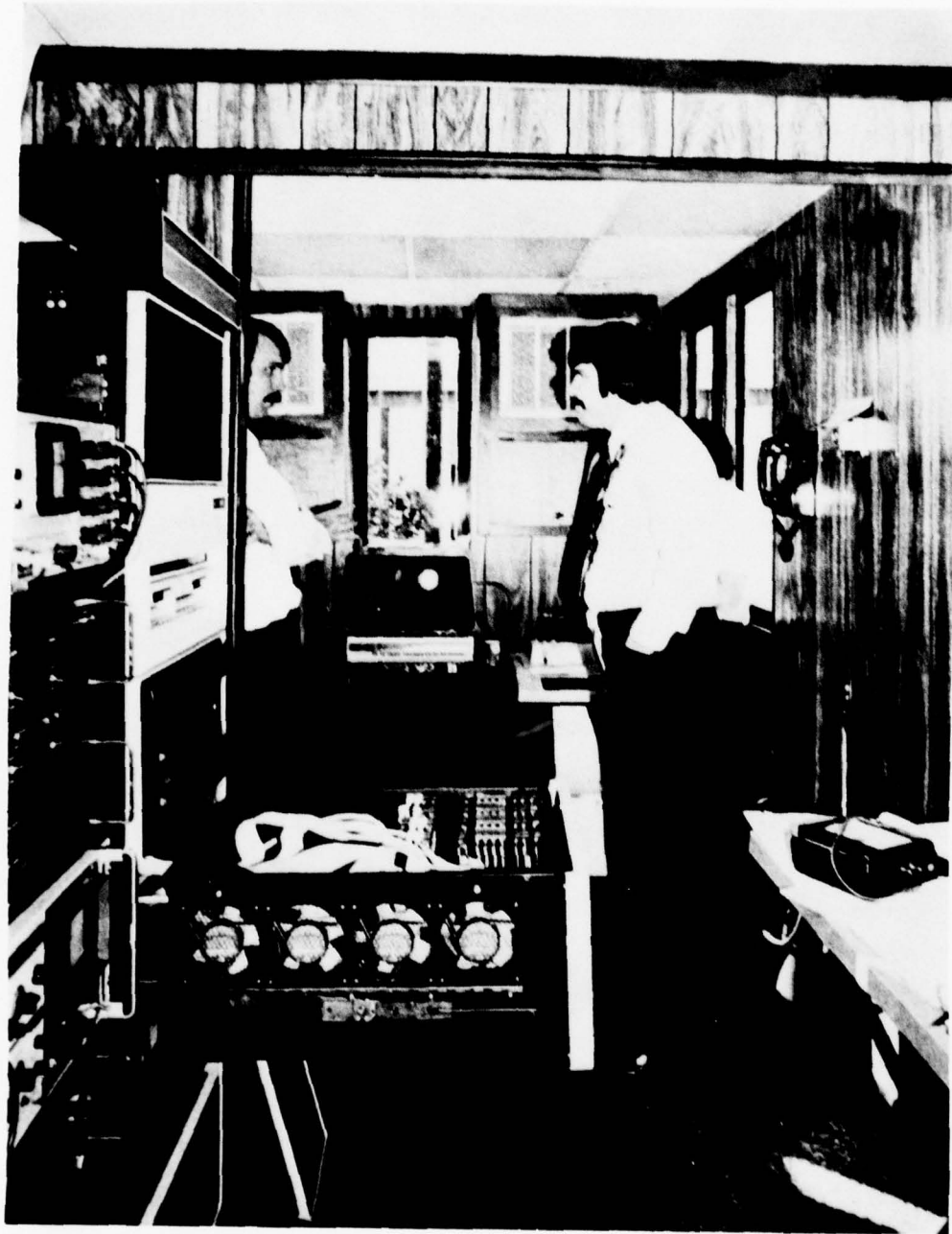

4-100

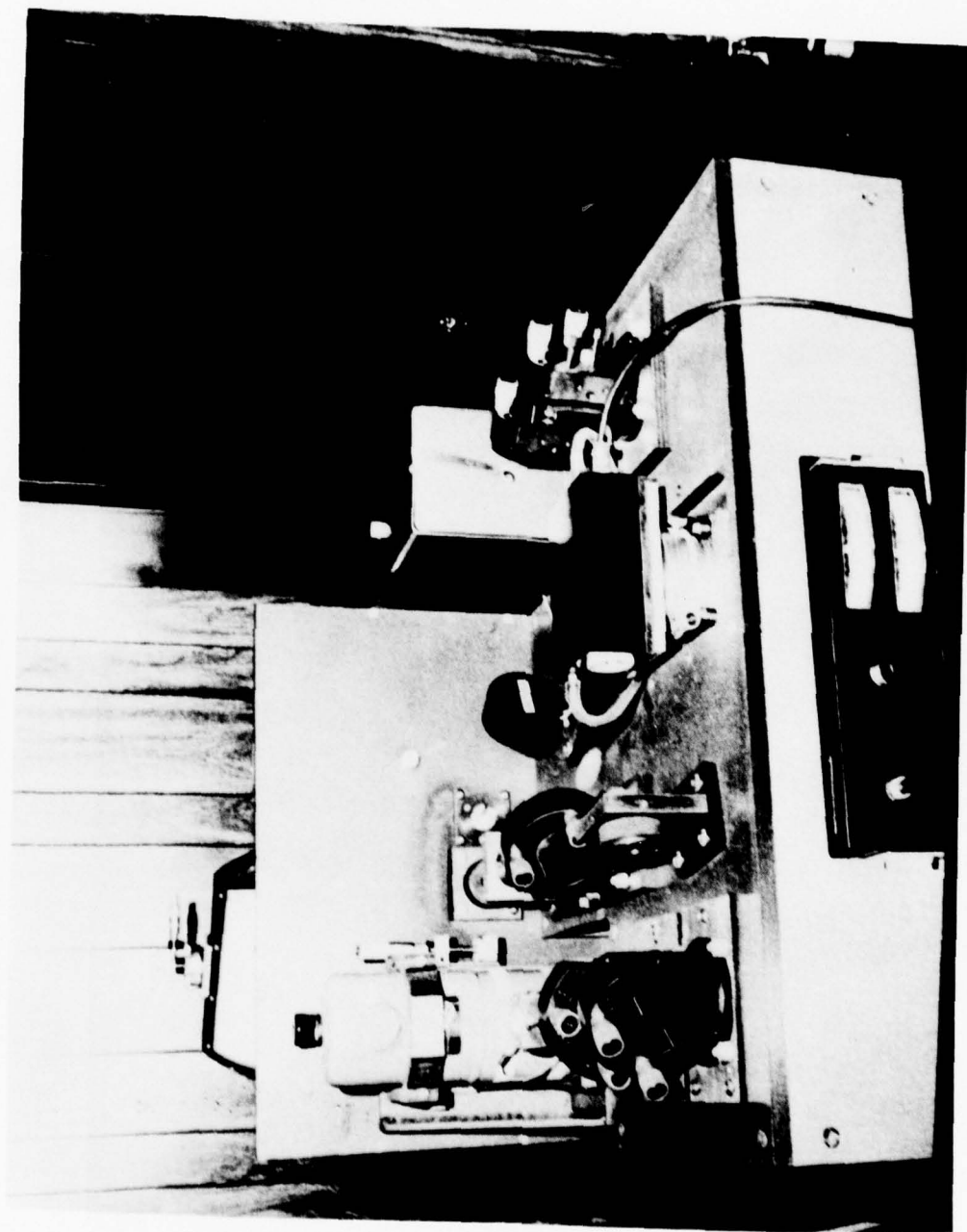

4-101

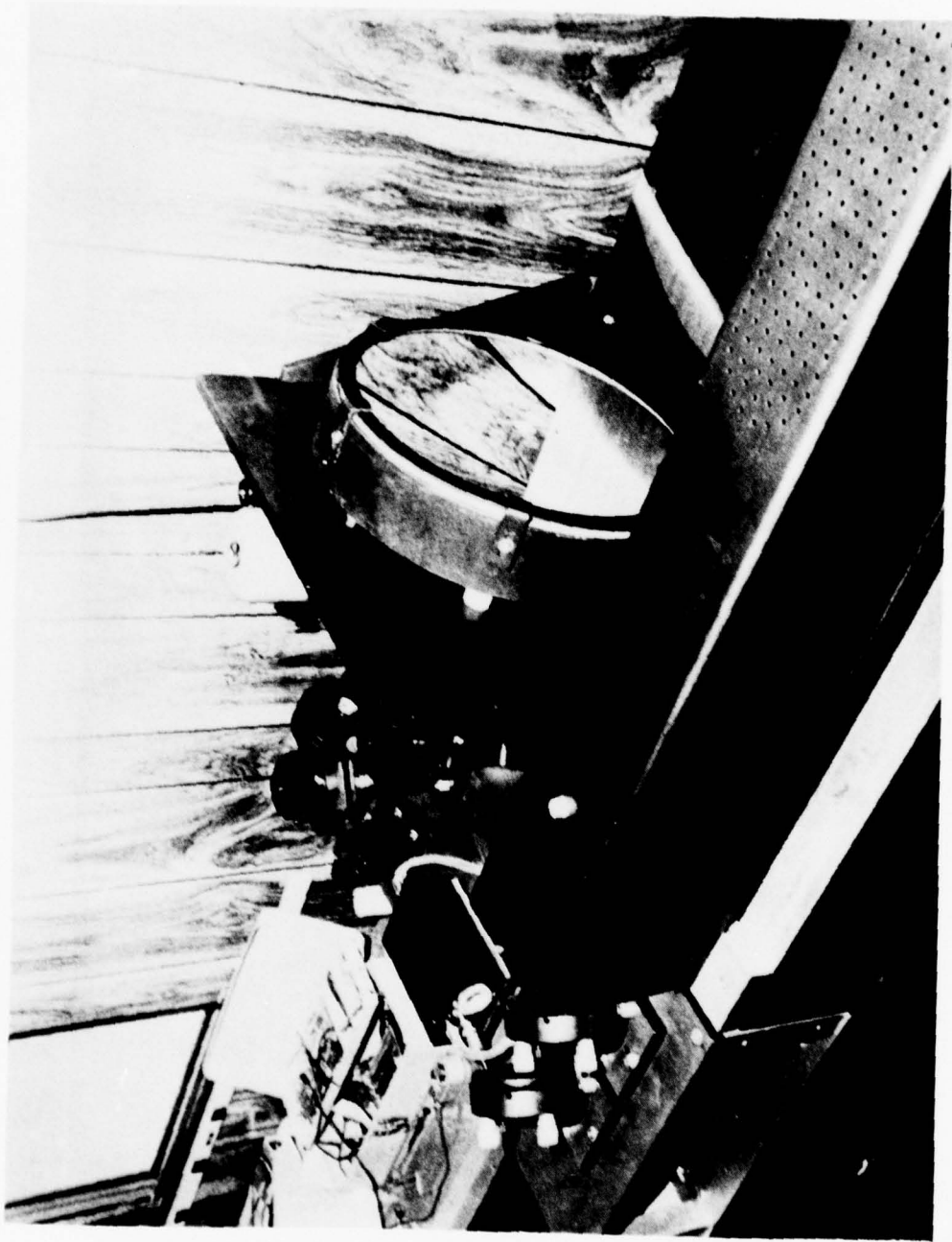

4-102

We feel that it's within the realm of reality. We've worked on a tracking algorithm with M.I.T. and have one that we feel is near being operable. I think in a short period of time, if we were pushed, that would be the device we would lean toward.

Thank you.

MR. TINSLEY. We don't have time for questions now. If you have questions and you're not going to be at our workshop tomorrow, get them to us any time, and if they are of general interest, we'll address them and answer them in the close-up tomorrow afternoon.

If you just want to personally talk about something, we'll be here, of course, for the cocktail hour and then all day tomorrow.

SESSION V

OPERATIONS, CERTIFICATION AND REGULATORY
ASPECTS OF VORTEX ALLEVIATION AND AVOIDANCE

DR. TYMCZYSZN, JR. : This is the operational session. I'm in Flight Standards Service at FAA Headquarters in the Air-Carrier Division. I'm an Aviation Safety Inspector for Air-Carrier Operations.

My dad's an Engineering Flight Test Pilot in the Western Region Certification.

Gene Barlow, who will be our first speaker is an Air Traffic Controller with a Terminal Operation Specialty.

Gene's been in terminal ATC operations for over twenty-five years. He was at Washington National for thirteen years as a controller and a supervisor; four and a half years at Dulles Tower, as a supervisor; eighteen months as a deputy chief of the Houston Tower; and then three and a half years at Washington Headquarters in the Aircraft Operations Division, Terminal Branch. Gene?

MR. BARLOW. Good afternoon.

This morning on the airplane coming up on Delta Airlines, I saw their company magazine. I picked it up and leafed through it, as customary, and there was an article in there by an author who has questionable credentials. It said he was a free lance writer and part time magician. I don't know what significance that had, but the article was on memory. It went on to say what a wonderful piece of machinery the human brain is, and that it retains just about one hundred percent of everything a person experiences in his lifetime. Though most of it is in his subconscious, it does retain that. So, it is quite a remarkable piece of equipment.

It also went on to say that the conscious mind will retain about ninety percent of everything it sees visually. This is done by a number of tests, similar to some of the tests that these gentlemen have gone through today and it indicates that the spoken word to a person is only -- Well, only about ten percent of that information is retained, and for that reason, folks, I don't have any visual aids today.

Okay. I'm speaking primarily for the Air Traffic Service. As it gets right down to the bottom line, what's it going to do

for us in the air traffic service? What's it going to do for the pilot? I will keep my remarks rather brief, as I don't have a whole lot to say at this point in time.

What will the VAS do for those of us in air traffic? The experts that you have heard today say that it will increase the runway capacity from, I believe, three to six aircraft per hour. In AT we don't know. We're just going to have to wait for the test results and see what that does. So, we cannot confirm or deny that.

What do we know about the VAS? From what we've been told and so forth, keeping in mind it is not currently operational at O'Hare nor has it been at this point, we know that seventy percent of the traffic landing at O'Hare is in the three mile category right now. That is a minimum of three miles. You're not always going to find them at three. They're going to be three, three and a half, four, and sometimes five.

We know right now from ten years of research that the surface winds, based on an annual cycle, indicate that we will have a green light condition about sixty-five percent of the time, the daytime hours for the most part.

The next item that we know, and this is because the decision has already been made, we have three categories of aircraft: **Heavy, Large** and **Small**. Small aircraft will not be included in the VAS separation standards. There's not enough safety analysis -- at this point in time -- to support our reducing that separation from the present five miles on final approach to a minimum of three.

It would be tough for the Cherokee to catch a 747 anyway in that five or six mile distance.

Analysis of the safety factors are presently limited to the area from the final approach fix outer marker to the runway. So what does that mean? That means, we're only going to apply VAS separation from the outer marker to the runway.

Non-precision approaches cannot be used with the VAS separation. Why? Very simple. Non-precision, the pilot gets to the outer marker, if he's, say, making a localizer approach, and he dumps it to his MDA, he's going to be down below the vortices, and that can't be tolerated, so non-precision approaches will not be permitted.

Another problem or another situation that we know about, runway occupancy during wet runway conditions and strong wind conditions is increased, and when this is increased, it's natural for the controller to increase his separation, even over what we have now, because he knows the lead aircraft is not going to get off the runway. That's a consideration.

VFR conditions. I don't think anything has really been decided on that. A gentleman a while ago in his speech said that there might be a likelihood of this equipment not being used in VFR conditions. I don't have a feel for that, but I don't see why not because we run just as much traffic in VFR conditions as we do in IFR and sometimes more. At O'Hare, in particular, the way they handle visual approaches is a little bit different from the way that they handle visual approaches at other locations because they control these airplanes.

They put them on a base leg, tell them when to turn in, and tell them when to turn final. They have more control over them than normal visual approach-type operations.

One of our concerns is, that the pilots who are making visual approaches today behind the heavy jet, may want to know what kind of VAS light condition exists, if it's red or green. If you say, red, he might think twice and ask for more separation.

Okay, surface congestion has been mentioned twice today. Of course, all of this is an integral part of the whole operation. VAS won't work without everything else working along with it. Additional capacity will compound our surface congestion problem.

Not too long ago I was at Atlanta, and one of the carriers called up and said, "Hey, we don't have any more gate space."

The Tower said, "We don't have a place to put them on a runway or on the taxi-ways either." So what do they do, they go on the hold for every airplane belonging to that carrier because they didn't have any gate space.

Another situation. If the lead aircraft is a Heavy, and he elects to go around, or execute a missed approach for any reason, gear warning, hydraulic problem, plain old-fashioned missed approach, if the trailing aircraft is a non-Heavy and his separation has been reduced below the normal five mile separation because of the green light condition, then we must send him around, too.

So, you've got two for the price of one on that one. If the trailing aircraft, following a Heavy, is inside the outer marker and the light suddenly changes from green to red, then he must go around. I'm contradicting some of the things that have been said previously, but these are things that have been determined at a later date.

What kind of AT procedures are we going to use? Well, I've spoken to that just a little bit. Outside the final approach fix it is going to be business as usual. Safety analysis is not available to support us reducing separation beyond that point at this time.

Joe will speak to that in a moment.

We have situations where there's a need for level flight for speed adjustment and spacing and stabilization on the localizer, et cetera, therefore, we're going to have to have the separation unless we can come up with some analysis that says we don't.

This system will not guarantee that air traffic can keep a trailing aircraft at a higher altitude, because of that reason. Now, realistically and logically if everybody's on the guide slope from twenty miles out, it would seem that you could close the interval up. At this point in time we really can't guarantee that.

Final approach fix to the runway. Our position in that is that a minimum of three miles radar separation can be authorized

for Heavies, behind a heavy and a Large behind a Heavy landing, making it touch and go, or stop and go on the same runway, when the VAS indicates a green light condition.

While we're talking about the runway, I would like to make a comment. I believe Hector made one earlier about runway selection. There was an inference that it might be possible that the controller would select another runway configuration because of a green light condition. I believe that's not a likely thing to happen at Chicago for a lot of reasons. In particular if you change runway configurations at Chicago, the delay that you would incur just by changing runways would be far greater than any benefit you'd gain from using a green light situation.

Next question. From the outer marker to the runway, how are we going to get from five to three miles? Okay, probably never. We guess probably four, four and a half miles will be the lowest separation that you would be able to accrue in that period of time. I think the important thing there though is the fact that in the green light condition, you can be assured, pretty well, that it's going to be a safe approach, and that's probably the most important aspect of it.

What will cause this? It's compression, at O'Hare, in particular, they tell everyone to maintain their speed, 160 knots, to the marker. So when they get to the marker and they start dumping their garbage and coming back on the power a little bit, and cross the threshold, 130 to 135, depending on the type of equipment, I suppose. So, you will get some compression out of that. If we can use that, the controller will not have to use a buffer that he uses outside and announce that at five miles, he uses five and half or six to take care of that compression. He can pull it in a little bit closer and let the green light condition take care of the compression.

As far as additional capacity, we don't know about that yet. We'll just have to wait and see.

Okay, next question. When do we plan to go on the operation? Well, we really don't have any firm plans right now. We've been talking about it just briefly in the last couple of days, but probably March or April. Now that seems like a long time away, but there are some reasons. Some of which are that we require forty-five days minimum lead time. Other organizations, I'm sure, will need at least that much time. We will need at least forty-five days to get our controllers on-board and brief them, plus the fact that the weather conditions prior to that are really not conducive to good green light conditions or an evaluation of those, because you've got wet runways in January, February, March. In March, you have windy conditions and so forth, so that the data that will be collected may not be a true picture of what you're really looking for, and that's why we're thinking about March or the first of April.

Okay. Potential problems in applying those procedures, the double go-around situation that I talked about. We've talked to O'Hare just a few moments ago -- I'm sorry, a few days ago, on what they can live with and they said, "Okay," considering that only about 15 to 18 percent of the traffic are Heavies, the times that we will have a situation where a Heavy will go around are probably small. We don't even have any figures on it. So, they said that they could live with a double go-around unless it got to be a real problem, and then we would just have to do something else.

Single go-arounds are another problem. I explained that to you a while ago. If the trailing aircraft is inside of the outer marker and the light goes red, he will have to go around.

Another problem, pilot non-acceptance of VAS separation. Okay, we have that right now with wake turbulence. We have pilots that say, I want ten miles behind the 747. Joe says, okay. Puts him ten miles behind him. Puts a DC9 in front of him. So, he gets his ten miles and he's happy, and we don't lose anything like that.

I don't know what will happen if we get a number of pilots that don't want the VAS separation. Probably go back to business as usual. I don't know how the airline companies feel about it, whether they're going to accept it or not. We'll have to see.

Other factors and some of these were already mentioned, I believe, and Hector had some on his view graphs.

Controller acceptance. We don't really anticipate any controller problems at O'Hare from what I understand from them. They have a pretty good understanding of it and would have no problem accepting it.

Another thing that we have to consider is pilot and controller training and familiarization with the equipment, and then, lastly, once we get all this done, we're going to have to publicize it in various publications and in the Airman's Information Manual.

Thank you. That's all I have to say, gentlemen.

DR. TYMCZYSZYN JR. : You know, when my dad was teaching me to fly one day, I had passed the outer marker on an ILS, I hadn't even done the after-takeoff check list, let alone the before landing check list, the gear wasn't down, I was really way behind -- I finally got down and he said, son, you're ten miles behind the airplane. Let's go up and try it again.

So we did. I didn't do any better that time, but this time I actually did worse because I spaced myself visually two miles behind a 707, and he said, boy, what are you doing? Were going to get killed. I said, not me, Pop, I'm ten miles behind the airplane.

MR. TYMCZYSZYN, SR. Thank you, Joe. This is the first time in my life that I've had the privilege of working with my son professionally. It's kind of a thrill.

Undoubtedly, the most interesting flight test job in the world is FAA Certification. I know the development of a new fighter plane for a company is great and so is landing on the moon and so on, but in the development of a new airplane you have a lot

of specifications laid out. Very often in the development certification of new airplanes, new navigation systems, new phenomena such as, wake turbulence, there aren't any specs to go by. You have to think the problem through and try to figure out what the regulations should read in order to achieve a certain level of safety, and ever since I got involved in this wake vortex business back in the days of the SST when we knew that the three mile separation was out the window, I've given considerable thought to it.

So the things we'll talk about here are not necessarily the things that are blessed by FAA, but I've taken them and discussed them with the best people we have in FAA and industry and NASA, and we'll give you the very best answers that we possibly can, and at the same time, we'll be trying to project and maybe incite a little bit of interest to make tomorrow's workshop a bit more interesting.

Certification, operation and environmental aspects of wake vortex alleviation and we might add to that, the same subject for any operation with VAS or WVAS.

I'd like to restrict my remarks to those items that apply to virtually all swept-wing jet transports since the spoiler and flap deflections are similar. You've seen quite a few view graphs today of various airplanes, and we'll show you two or three of them, but I can assure you that the 747, DC10, 1011, the air bus, 767, and so on are very, very similar in regard to the location of spoilers immediately ahead of the outboard flap.

The second point we want to make is that alleviation is potentially applicable to other than **Heavy** aircraft. We've sort of gotten into the rut of thinking only of the big urban airports, maybe fifteen or twenty of the large airports and Heavies, but since airport capacity and safety may be enhanced at airports with other than **Heavy** aircraft, it's something that we ought to be thinking about also.

For example, Orange County Airport and Van Nuys Airport and Washington National are all equally important and what I'm trying to project is that these techniques are equally applicable to them.

Okay, a very quick plan view of the 747 shows twelve spoiler segments. The ones that we're interested in are the ones just outboard of the outboard flap.

This is the 1011. The only thing different about that is Lockheed numbers everything from the center outboard.

This is the new 767, and you see that, again, the spoilers are located ahead of the outboard flap. If you look at the Russian IL62 and the British VC10 and a whole bunch of other airplanes, you'll find a great deal of similarity and therein lies the secret of potential attenuation with vortices.

The genius of Boeing in designing the first -- very first 707-AD, the 367-AD, has shown through in the whole family of swept-wing airplanes.

Now, I'd like to spend just a little bit of time with these small separation standards. I know you must be a bit tired of them, but let's look at them and see where they came from.

The box on the left shows the three categories of airplanes, and for a moment I'd like to skip to the definition of these.

The **Heavy** is any airplane certificated to a takeoff gross weight of 300,000 pounds or over.

The **Small** airplanes are those airplanes certificated to a take-off gross weight of 12,500 pounds or less.

Everything in between 12,500 to 300,000 pounds, is called a **Large** airplane. That's a ratio of 24 to 1 in terms of weight.

Obviously, you have either excess safety for some of those airplanes, say the airplanes that weigh 290,000 pounds compared to those that weigh 14,000 pounds, or putting it a different way, you say excess separation with decreased airport capacity for a lot of the **Large** airplanes.

In the beginning, we originally worked with four categories. The dividing line was roughly 150,000 pounds which was the, well, sort of the upper end of the small 727. However, think about the permutations and combinations possible with four categories of airplanes.

Note also that this term, category, class and type get to be overused in FAA. The different categories for ILS approach, and there are different categories for wake vortex, pilot ratings, and so on, and we're hoping that one of these days we can put all of those into the same categories and have the same definition.

But if you want to get an immediate increase in airport capacity, you might for a particular airport consider seriously splitting the large category into two.

Okay, if you look at the long term goal in the box to the right, and I got this out of an FAA report done by Mitre Corporation in June, 1978, June of this year, look at the bottom line. You'll see that the Small, Large and Heavy airplane behind the heavy are cut down to exactly one half of the present requirements.

That's quite interesting, because we have been working on the concept that if we can cut the separation to one half with equal safety to what we have today, then we will have accomplished something. So, the people working on airport capacity and the people working on attenuation are not too far apart.

A more optimum system would be to say, let's everybody go to a three mile separation. Therein, I like to point out in the next few minutes why this may not be unreasonable.

Based on the tests we have done behind the 747, 1011, and some informal testing behind the C5A with lift distribution control system, I'm making the projection that this reduced separation can be achieved.

Okay, let's look at some of the certification problems, the operational and environmental aspects of it. Handling qualities: I'm just putting one sentence down. Jerry Lundry did a darn good

job of pointing out some of the details of it, and I'm saying that there are no major obstacles foreseen, but everything there requires a review of the trim range -- You'll have to increase the trim range of the trimmable stabilizer on the 747. You'll have to look at the stability. You'll have to look at the lateral control, one of the problems that Clive brought out, lateral control.

Suppose we come up with the 747 with spoilers 2, 3 and 4 at fifteen degrees, and you use these for lateral control. Obviously, you don't want to have differential spoilers at that time, but we'd leave that to the genius of the aircraft manufacturers who can then say, okay, let's leave that at fifteen degrees. Say I want right roll, leave the left wing at fifteen degrees extended and apply more spoiler deflection to the right wing, and keep the same roll rate, if that's what you're after.

The other part about handling qualities is that in the landings today with the 747's and 1011's with gross spoiler deflections -- those first attempts that we made -- the pilot had absolutely no trouble with landing; none whatsoever.

The second one, the biggest one, is obviously the noise, and it had me worried for a long, long time because we were using rather gross spoiler deflections. Now, our noise estimates are reduced from one-half dB, that's actually six-tenths of a dB, to three dB, and the sources for that are Lockheed and Boeing in this regard.

The ultimate spoiler deflection for good attenuation may not be too far from what the Lockheed 1011 has for DLC, Del Croom's 747 configuration using three spoilers at fifteen degrees is not too far different in terms of spoiler volume than the 1011 has for using four spoilers and nulling about seven degrees. In any event, the 1011 increment for the spoiler deflection DLC on and DLC off was six-tenths of a decibel.

The gross configurations we had previously were three dB. The latest estimate we had on Del Croom's latest 747 configuration that we hope to fly behind in January, is nine-tenths of a dB.

Perhaps that would be acceptable as a trade-off for increased airport capacity and safety and would not require any engine treatment for quieting the airplane down again.

Item number two, the increased drag on final approach uses six to fifteen percent more fuel. The basis for this is the flight tests that we've done on the 747 and 1011. What we did was take the EPR and fuel flow charts for the configurations we looked at and went into them.

The 1011 DCL, if that represents an ultimate hope for attenuation, is six percent. Now, if fuel costs fifty cents a gallon, then each two and a half minute ILS approach will cost between two dollars and five dollars more per approach, and I don't think that anyone can argue the cost effectiveness of numbers like that.

Another thing about the drag is that it has characteristics that have become the favorite of a lot of pilots. One of the nicest things about the 1011 is the DLC and, again, we'll talk on this a little later.

Item number three, a safer airport environment. If you reduce the energy concentration from the vortices, it allows for safer movement of small aircraft. Okay, what do I mean by that? About two or three weeks ago up in Seattle at Boeing Field, a 747 rotated and a 182 was parked on the taxi-way 120 feet away and it flipped it; the vortex from the take-off rotation flipped it. Well, obviously, that's take-off. It's a bit stronger than landing, but there's nothing preventing strong vortices in a landing configuration from inundating the approach end of the airport and causing a problem to both light airplanes and helicopters.

So, as soon as you diffuse the energy in a vortex, retain the same vorticity but just kind of scatter it out, you create a safer airport environment.

The next one, less potential effect of vortex impingement on alpha and Q sensors. As we get into the more exotic airplanes with reduced static margins, energy efficient airplanes, you'll

find more and more of them will be flown with extra sensors. A lot of our modern, sophisticated airplanes have alpha, angle of attack sensors, and Q sensors, auto-land sensors and so on.

Now, can you imagine one of these sensors being impacted by a vortex tube, say two or three feet in diameter and with velocities of two to three hundred feet a second -- they'll go crazy. All you have to do is stick the nose of a Lear Jet into one of these things and you get stick shaker and stick pusher and everything else all at once. The same way, you stick the tail of the 707 or 990 into it, and impinge on a Q sensor and your rudder goes crazy.

So, what I'm saying is that as you emasculate the vortex strength, you cause a reduction in its concentration and create a safer airport environment for all aircraft operating in that area.

Okay, item four, the less potential damage from engine ingestion of concentrated vortices. This has been a favorite of mine, and I'm having great deal of difficulty convincing our FAA propulsion people that we need to consider this very strongly. But consider first of all, that a DC 10 engine, for example, has about two, two and a half times the thrust of a DC 8 engine. But its potential for picking up birds and picking up vortex tubes, is some five to seven times greater because of its area. You have more chance of picking up a vortex tube.

In addition, you have a short inlet. The compression distortion allowances of the more sophisticated engines, the high bypass ratio engines, is probably not as good as the old engines. Therefore, you can get compressor stall and flame out.

We have examples of this. A C141 behind another 141 about a mile away had three compressor stalls and a flame out. We position a Convair 990 about a mile behind a 104, a little tiny 104 with a vortex tube that big, killed number three engine.

There's a report of an SAS 747 going out of J.F.K. some ten, fifteen miles in a climb-out behind another 747, he had compressor stall and flame-out. He suspected wake turbulence, and he had to come back to J.F.K.

The problem here is that it's very difficult to track these things down. We're talking about those things that we'll have to look at in the certification phases. Now, when we look at reducing separation by any means, whether its VAS or WWAS or attenuation, the instant that you say you want to reduce separation, we'd better start looking at potential engine problems.

Five, greater freedom for airport runway taxi design layouts. As you reduce the concentration again, a lot of airports don't have the real estate to have a hundred and fifty foot lateral distance between runways and taxi-ways for large airplanes, and two hundred for Heavies. This gives you a little safer environment to move these airplanes around.

Okay, in terms of performance, you can go on and on here. Basically, landing-climb performance on the 747, even with gross spoiler extensions was no problem since landing-climb is an all engine condition.

However, there is no reason to even consider that. But in terms of performance the most important single consideration is that I feel after a great deal of discussion with our flight test performance engineers, that no increase in landing approach speed need be tolerated, and no increase in landing distance need be accounted for if we're talking about the kind of spoiler deflections that we feel will be achieved to get the desired attenuation.

The basis of this is the certification of the L1011 and DC10 and DLC. The philosophy was that you are merely trading drag for thrust with some inherent advantages.

If you have more thrust, engines that are a little higher rpm, you get faster response from opening the power levers, such as a wind shear, for example, and you get instant lift by collapsing the spoilers. It does create the momentary problem of increasing the vortex for the guy behind you, but Gene talked about the necessity of sending two guys around if the first has to go around.

There are several provisions on this. One is that auto-spoiler retraction at approximately the stall speed or roughly 1.15 times the stall speed be programmed. I went back into aviation history and found five FAA reports where we looked at the landing touchdown speeds for transport airplanes and invariably the airline transport pilot is interested in landing between a thousand foot marker and a fifteen hundred foot marker. Believe me, they don't get a bonus for the smoothest glide on landings. They want to put it down on the same spot on the runway. They touchdown something like 1.25 times the stall speed.

There's nothing wrong with landing with the spoiler volume that we have been talking about. Therefore, we reason that there's no reason to figure that you have lost some C_L and you have to have a higher landing approach speed.

We don't account for it in a 1011 or DC 10 certification. I might add that even though the DC10 was certificated, it never did go through to completion for other reasons.

Item number two, no loss in landing-climb performance deemed necessary, provided that auto-spoiler retraction be programmed for go-around procedures, and this item does need development. We're going to have to work very, very carefully with air traffic control in order to work up the procedures for this.

Item number three, there are other advantages of extended spoilers. First of all, it's akin to direct lift control in the wind shear, and Clive mentioned one of the problems there, but fortunately, wake turbulence and wind shear don't occur at the same moment. They are on opposite ends of the spectrum. Generally, wind shear occurs during periods of very high wind, and wake turbulence generally occurs in relatively lesser winds.

Faster thrust response, instant lift -- The summary of it is that you have a safer airplane with a spoiler extension during final approach.

I'd like to mention these other operational certification items, particularly for the workshop. One is the helicopter's

vortex generator. A Bell 205 at Van Nuys not too long ago with a southeast wind blowing, came in and made a 180 degree turn and landed and the vortex blew over. It caught a 150 at landing approach and destroyed the airplane.

The second is the explosive growth of helicopter IFR usage. Helicopter IFR in a beautiful, new, twin turbine helicopter is at the same point in development that the executive jet was some eighteen to twenty years ago. There are five new beauties. So, there's a big push on for helicopter IFR usage, and we've certificated some of them, and you fly exactly the same ILS that an airplane does. So that guy now has a threat from the airplane ahead of him.

The third item is vortex impingement on a glide slope during temperature inversion. I wish I knew more about the life of vortices during inversion conditions. I do know after tracking quite a few of them that we cannot depend on the vortex trail going down and staying there during unstable atmosphere conditions.

The last accident on Memorial Day at L.A., an experienced pilot, two and half miles behind a 707 VFR, said that he was well above the glide slope and a 707 pilot was on it, but he still got flipped and the airplane was destroyed.

Item four is one of my favorites, and that is an electronic or barometric bias for general aviation and helicopter ILS receivers. With the genius we have in this country, I don't quite understand why we all have to fly the same glide slope. If you can imagine a glide slope antenna sticking out on a stick one hundred feet below your airplane for general aviation airplanes, you would have one heck of a lot safer approach.

Combine that with displacing the threshold for general aviation and executive aircraft, and you see that you'll solve the problem at least for the landing part of it.

Six -- Okay. These are other items that we're thinking about, and I will have a little more time for tomorrow during the workshop.

Thank you.

DR.TYMCZYSZYN JR. : I want to clean up a couple of items on VAS.

Volume One of the Safety Analysis that Jim Hallock talked about is being circulated for comment. We don't have most of the comments in. We hope they're favorable.

Volume Two, the Laser Van Data, hasn't even been published yet, but Wood and Hallock have told me that it looks pretty good.

Assuming that these are accepted by the industry as valid proofs of the safety of VAS, we will start up around April 1st. This is, as I said, pending acceptance by the industry of the safety analysis, however, we still plan to give a pilot who does not believe in VAS, increased separation if he requests it.

But, of course, if most of the pilots didn't believe in it and wanted to increase separation, it would defeat the program. So, that's why we're trying to get people to accept the safety analysis.

If there is an incident, some pilot using VAS calls in and says that he got flipped or he had a big problem, we're going to stop VAS right then until we can investigate and find out what happened.

One good thing about VAS is, we've already got the low level, wind shear alert system funded and moving ahead, and it used anemometers, too. I won't explain it in detail, but by converting the low level, wind shear alert systems to VAS systems, which we are trying to do now, we've got a lot of leverage.

There are seven low level, wind shear alert systems in operation now; seventeen more by the summer of '79; thirty-four more by summer of '81. So, we've got a big potential for a lot of VAS's, if we need them. We don't have to justify the whole cost

of the VAS based on the VAS because we have the anemometers in place.

I want to turn to VAS enhancements, and WVAS. One possible enhancement would be to use shorter separations outside of the outer marker. We get a benefit from it, but as Gene said, we haven't been able to prove that that's safe yet. So, we're not doing anything about that now other than looking at the safety of it and maybe someday we'll work on the safety analysis for that.

If we never can show that that's safe, we probably can show that it's safe with alleviation which would mean a combination alleviation and VAS. The alleviation would work outside the outer marker.

It brings up the interesting operational question of do you use alleviation on a particular approach if the VAS light is green? Or do you only use alleviation when the VAS light is red?

If you use it only when the light is red, you'd save some noise and fuel, but you'd have non-standard operating procedures, and more training. Also, there'd be a larger chance of an error for a pilot forgetting to press the alleviation button which would be dangerous for the guy behind him.

There are just two operational problems with WVAS that I wanted to mention which we can discuss tomorrow. One is how late can a flight crew or controller wait on an approach to find out that he's got to go around, either due to the vortex failing to clear out, or say, the lead aircraft not clearing the runway?

Secondly, with WVAS we have the possibility of adaptive spacings depending upon the wind and the other types of aircraft and so forth. There you would have a situation where the pilot and the controller were in the dark about what their spacing was going to be, because it was chosen in real time by a computer, and it might be a tough thing for a pilot or a controller to handle.

Now, alleviation -- I want to talk about certifying that the following aircraft is safe to fly X miles behind the alleviated

aircraft. Now, we don't know right now what kind of a certification program this would require. We'd like to discuss it in the workshop. We expect that it will be a combination of three things: One would be flight tests, like the ones that have taken place, including landing; another would be a safety analysis, like Jim Hallock has done; third, would be the laser van measurements.

There is a complication in this, and the VAS safety analysis was based generally on not hitting the vortex, but with the alleviation the vortex may be benign enough in order to hit it on a frequent basis; but we would have to define what benign enough means, and I think we need NASA help for that.

One possibility that we have is certification of the safety of the follower for example, perhaps with alleviation a 747 could be recertified so to speak as a Large and not a Heavy. In other words, with this alleviation it wouldn't create any more vortices than a Large today. So, -- for example, Northwest 3, which is a 747 flight, would no longer report into the controllers as Northwest 3 Heavy; they just report in as Northwest 3, and that way they could be given spacing of Large aircraft.

It would be somewhat simple to handle. The controllers wouldn't have any particular problem with it, just change the call sign and change the flight strip -- that is, if the alleviation works, and we can certify it.

There are a few complications. One is if the 747 which we've recertified into the Large category had to do a missed approach and stopped alleviating, then it's no longer a Large. Then, perhaps we need a confirmation to the controller or to the pilot behind or someone that the alleviation is really being turned on.

Of course, in the future alleviation might get so good that you could certify the 747 not in the Large class but in the Small and fly three miles behind it, or in the tiny category and fly two and a half miles behind it.

As previously discussed today, we may want to redefine Heavy, Large and Small based on the vortex strength on approach and landing, rather than today's system of just taking the maximum take-off, gross weight, which doesn't have that much to do with what's going on in landing. That would accomplish two goals, it would make the system more effective and rational, and it would take alleviation into account. So, a 747 that was alleviated could be called a Large or Small.

I doubt that we could do this without NASA help, and I'd like to discuss it in the workshop.

With WVAS, we might have adaptive spacings so that aircraft would be certified to not 3, 4, 5, 6 miles, but 3.4 miles -- get it down that close. In addition, there might be a need for two numbers to describe a given airplane, wake vortex-wise.

One is the lead aircraft and one is the follower. For example, the Concorde puts out a very strong vortex, but as a follower, it's not as good. It has such a short wingspan that it can be emersed in a vortex and it doesn't have as much ability to be a follower as another airplane that puts out as strong a vortex as it does.

There's an interesting side-light here, that's with MLS. If you have different three-D paths, then it really makes the safety analysis for wake vortex complicated, but you could use that to your advantage if you have the smaller aircraft come in higher and upwind of the larger aircraft, and by higher I mean not only at steeper glide slopes, perhaps, but land further down the runway, too.

Now, we come to somewhat of a bottom line here and that is -- seeing that I'm in Flight Standards, we've got to talk about rule-making and regulatory aspects. I want to list some alternatives for rule-making, and not give any particular preference, just maybe discuss them a little bit. We have to spend a lot of time on this in the workshop.

Alternative number one is for FAA to push this very strongly. Say that in order to foster aviation, we've got to push rule-making. We've got to put out an ANPRM requiring alleviation for all such aircraft; new aircraft by such and such a date, and after another date, we require a retrofit.

Now, if we had done this, I guess I wouldn't have had to inject the following comment and say that FAA is, you know, neglecting wake vortex -- neglecting alleviation. However, I frankly think that if we did put out an ANPRM now stating that type of thing, that we'd get an overwhelming number of boo's from the airlines and the aircraft manufacturers.

I definitely want to discuss this tomorrow.

Another thing would be to test the water with the ANPRM. Let's put that out and get some comments and then decide what to do after that.

Another thing, another alternative would be for FAA to wait around, take no particular rule-making action now and then wait until the airlines came to us saying, damn it, this thing has favorable economics and we need it, and the reason that we need rules is to keep it fair among airlines. So that Airline A wouldn't spend a lot of money modifying their fleet; Airline B not spend a penny and have both of them reap equal benefits. It wouldn't be fair to the guy that paid for the alleviation.

There's still some inherent unfairness in the system. For example, Pan Am's fleet is mostly Heavies, and Allegheny's fleet is mostly DC9's. So, you know, Pan Am would pick up a lot bigger cost than Allegheny to accomplish the same benefits.

Also, there is a question of foreign operators. Alternative four isn't strictly rule-making; it's more FAA policy. We could base landing fees or encourage operators to base landing fees on the amount of time an aircraft ties up a runway. So, if it ties up six miles behind it, charge it twice as much as an aircraft that ties up three miles.

Now, the fifth alternative is more in the form of an advisory circular rather than a rule. Flight Standards could put out advisory circular on how to recertify a Heavy as a Large or a Small for the purposes of wake vortexes.

Then we could let the aircraft manufacturers or the airlines do as they please about that. Of course, with our manpower shortages and our normal way of doing business, we don't normally write advisory circulars unless we have serious applicants, but this would be the way to go without twisting arms. It would provide a means for people to pay their money and get benefits.

Now, on a number of these things, in terms of certification, I don't really think we can do it without NASA's help. We got the bad news from Al Gessow just this morning -- well, some of us knew it before -- that NASA's about ready to stop putting money in this on a large scale. So, FAA is going to have to show increased interest, and I think that's going to mean increased money, too.

Flight Standards doesn't have any money for doing development. So that means that Flight Standards would have to ask E & D to help set up programs with us and NASA to do some of the certification work for wake vortex alleviation.

So, Neil and Dave and Sig, I'm afraid you're going to get 9550's, letters from FSI asking for financial help, in addition to manpower on setting up the studies and development for the operational and certification aspects of alleviation.

The last item is separations less than three miles. This is the purpose -- The purpose of the conference is not separations less than three miles, but we all know it's a goal, and it definitely can't be ignored in a meeting like this, especially with Air Traffic and Flight Standards people here. One of the members of the audience is Ralph Irwin of Boeing, sitting over there, and he had an article in this month's issue of *Aeronautics and Astronautics*. Here is a graph that shows potential benefits of going to short runway occupancy limit separations, which is about forty seconds or a mile and a half. There are many benefits from it,

but there are many safety problems such as operations acceptance from pilots and controllers.

So, I propose that tomorrow we discuss the -- What we need is to get pilot and controller acceptance for separations less than three miles, for a short enough time not to detract from the primary purpose which is wake vortex, but a long enough time to air the issues and convince the people we are worried about it.

That completes my talk. I guess I'll turn it over to Bob Wedan or Ken Hodge.

SESSION VI
WORKSHOP ORGANIZATION DISCUSSION

MR. HODGE. In Session 6, we hope to get the workshop organization covered here a little bit and permit you to have an introductory meeting with the chairman of your workshop before the bar opens tonight. The bar will not open before six, so I assure you that Bob and I will be fairly brief. For those of you who have signed up and registered, you've received in your registration kit a piece of paper that tells what the three workshop titles are and where they will meet, and from your final agenda program you know who the chairmen are, but in any event there are some people here who are not registered and who did not sign up for a particular workshop. Just let me go through them very briefly.

The first workshop is entitled Wake Vortex Alleviation at the Source. The chairman is Joe Stickle. You've seen Joe up here at the rostrum, so you know who he is. The meeting will be held in the Management Information Center on the twelfth floor of this building.

The second workshop is entitled Development of WWAS on the Ground, and the chairman is Guice Tinsley. Colonel Tinsley was up here before and will host that group on the ninth floor in Room 947.

The third workshop is entitled Operational and Safety Procedures and Joe Tymczyszyn, Jr. is the chairman. That workshop will meet in Room 1120 on the eleventh floor.

I would also suggest that where a company or an organization may have more than one representative here, that perhaps you might distribute yourselves between the workshops in order to provide perhaps the broadest base of representation to the workshops.

The workshops will meet to review the issues and questions in their various areas of concentration and in a few minutes Bob Wedan will talk a little bit about the philosophical issues. But I think that it's very essential that you meet with your chairman to discover what workshop ground is to be covered and the scope. It may be that there's additional scope that needs to be identified tonight, so that when you meet tomorrow at 10:30, we'll cover all the essential points.

Now, after Bob and I are through here, you will meet in your respective rooms with the chairmen, and there's nothing that says you have to break immediately at 1800 to meet in the bar. You can go a few minutes beyond that, I think, if you need to.

Then, again, you regroup tomorrow at 10:30, after having heard here, as openers, the views of the various interested organizations and groups. Please note that the bus leaves the hotel at 7:45 tomorrow, rather than 8 o'clock.

The output of these workshops will be reports back to Bob and myself tomorrow to be presented starting at 3 p.m. and we've allowed thirty minutes per workshop. We will provide support to the workshops for making view graphs and for having material typed, as far as I know. So, there's no specification for what the report should be, but please leave us something in writing so that we won't have to go up and copy notes off a blackboard.

Ultimately, we want to present all this in a record, which will be the proceedings of this conference.

Well, I think I've covered most of the essential points here. If I haven't, Jerry Chavkin will remind Bob probably before we step down.

So, I'll turn this over now to Co-Chairman Bob Wedan.

MR. WEDAN. There's a program on television on Sunday morning called, Issues and Answers. What we've been hearing today to a large extent is issues and problems, but the thought that I'd like to leave with the people who will be participating in the workshop sessions is that we're concerned about the answers.

I think that we've had a good display of the problems. We know pretty well what they are. We've been reminded even if we knew them before. But now, we're interested in answers.

Looking back on it now, just briefly, I think that you'll agree that together -- altogether -- NASA, FAA, TSC, industry, participating contractors, we've achieved some significant milestones.

The VAS system that's under test at Chicago is an accomplishment. It's a major accomplishment and I think that, taken together with the very significant work to develop what appears to be important attenuation schemes -- important in the sense that they look practical thus giving us an opportunity to move forward with that type of a scheme, these two things represent perhaps the two most important milestones.

We also have analysis that continues to show significant payoff potential. Maybe not this year or next year, but as we look ahead to the years to come, the payoff appears to be there, although we have had a disturbing lack of inputs from the airlines. They've been silent about this, but I think as they sense the build in demand, the answers are going to have to be available at some future time.

Both Doctor Kramer and Neal Blake indicated this morning that we're soliciting guidance on how we should proceed from this point. We've got these accomplishments, but now the question is, how should we proceed from here?

The program is -- as Ken pointed out on the back of this, it indicates that both he and I are looking for recommendations. Consider us as the means to channel these recommendations into the system for thinking about how programs should be structured in the future.

Although we've heard from Al that there are specific plans to close down major efforts within NASA, I think that a lot depends on the expressions that come back from the using community as to really what happens.

Wouldn't you agree, Al?

I think that's true within the FAA, too. So, although neither Ken nor I are looking for a specific program to be laid out in a matter of two or three hours, that is complete with resource requirements, I think it's helpful to keep in mind that, in fact, is what we're looking for at the end. He and I and others that we work with, have to come up with specific program recommendations.

Our bottom line is to recommend in our budget exercises specific program descriptions for next year, the year after, and so on. What we hope to achieve from these workshops, therefore, are inputs that are directed toward that end.

Let me give you an example. As you've heard, we've essentially completed the development of a Vortex Advisory System. To take the next step, there's a vortex avoidance system, that requires a substantial effort over a number of years, I'm sure.

It may include the development of an active tracker. You heard of the difficulties in obtaining an active mechanism for actually measuring in an active sense where a vortex is, but that thing may have to be developed. If we're going to close up aircraft closer and closer to each other, we might want to be able to detect that maverick that remains in there even though it's predicted to move out, so that we've got a last minute go-around capability.

That may be required. If so, you could see from the previous discussions the state of the art is such that we have to move essentially out of the laboratory into something that is operationally feasible, and that requires money. It requires a hard program to make that happen.

It may also be necessary to tie into the terminal automation system. As mentioned earlier perhaps a real time system that looks at actual aircraft -- as tracked by the computer to pair up aircraft in some optimum way or at least to know who's in there, it may have to be done. For us to get in there to interact with the ARTS-3 system, is going to take a considerable effort.

So our question is: Are there things that we should do? Is there further work that needs to be done with respect to the attenuation system in the aircraft? Are there certification techniques that need to be pursued? These are engineering questions, do they require engineering resources to continue the work?

So, the sessions, as indicated by Ken, will get underway now for a few minutes to get yourself organized and tomorrow's going to be a work time.

I'd just like to suggest that you take advantage of every moment, including the social hour, when perhaps during that time some hot ideas may be generated that might prove to be productive tomorrow.

Just one more comment before I let you go and that is, tomorrow we do intend to hear other inputs from the community, specifically those that are on my list, Air Transport Association, ALPA, and comments from the Netherlands and the United Kingdom.

If there's anyone else who wishes to make a statement on the subject, please let me know before 8:30 so we can work you in.

MR. PORITZKY. Bob, I wanted to underline one point and ask a question perhaps a little more directly than you just did. I was going to do it in the context of a question to Bill Wood and that relates to the question of wake vortex avoidance, detection, or what have you, below the three mile situation.

All day today, we've heard about the possibilities of operating under three mile wake vortex conditions. Joe Tymczyszyn touched on the possibilities of going below. I think if Bill Wood, had had another minute and a half when he spoke, he would have had something to say about his views on the requirements for additional sensors in going below three miles.

Now, I believe it's important to ask him that question, because I think it will be useful to the workshop simply because I think we learned this morning that the only game in town to get capacity, which is what the air carriers say is their number one problem at this point, is reduction of longitudinal separation given that you don't get new airports, which don't seem to be around the corner.

Now, one of the questions that we've asked ourselves a fair amount in the R&D community, at least, is: Is it really worth

trying for separations below three? We have fairly good evidence that barring the wake vortex problem, you can realistically think about two and a half, maybe two someday, but certainly the possibility exists for two and a half, given the wake vortex problem can be reduced and given that the many problems that Gene Barlow talked about can be overcome and you gain a benefit.

But I'd like to ask, if you can take another minute, to let Bill Wood talk for a moment about his views on the importance and status of both the turbulence detector, which raises that percentage capability significantly apparently, and then his thoughts based on what he's done so far on the importance of moving forward rapidly with a detector when you get below three, because one of the crucial questions that I hope will be answered tomorrow -- out of the workshop -- is: Judgment, is it really worth trying to go below three miles or is that sort of silly? Would it be possible for Bill to come up?

MR. WEDAN. Oh, absolutely. Bill, can you spend a minute, and cover those points?

MR. WOOD. Let me address the turbulence problem, first. A large percentage of the data that was collected at J.F.K. was done with three-axis anemometers. It was not done with the type of device that you saw in the VAS, which is a rotating-body-type. That means that we had access to turbulence information. That means that we saw the effect of that wind measurement, the third axis wind measurement on the vortex. We know what it will do. We know what it will take to make that kind of measurement. So, to get the turbulence, to get some kind of turbulence device into the system is not a major undertaking. It's not beyond the state of the art, let's say that.

We're not convinced, yet, that we want to make the move and put the anemometer in the VAS system. There may be a simpler solution. I think I briefly touched on the measurements we made at J.F.K. with a device called a pyranograph, which looks at the cloud cover. It strictly looks at the amount of turbulence you're

getting in the air. When it's a cloudy day, you're likely to not see as much turbulence as you do on a bright, sunny day.

We've seen enough effect out of that simple device to know that it can be effective. We've got an awful lot of data to reduce to get to the point where we can make that decision. But the data is there, the measurements were made. I don't think that enhancing the VAS with a turbulence measurement is a tough problem. It's a time-consuming one. We'll have to decide which sensor and how to put it into the algorithm, but it's not beyond the state of the art, and the measurements are available now to start that work.

Going beyond that, and looking at a sensor to do tracking, if we have to get below three miles, we feel today that we'll have to go with some type of active tracking. We're not going to get there by just enhancing the VAS and trying to work that route. I think we'll improve the effectiveness of the VAS with turbulence. We won't get below three miles with it. We'll still be three miles, but instead of being fifty percent or sixty percent effective, we'll be up in the eighty-five or ninety percent effective region still at three miles.

But if you want to go below three, I think it's our position right now that we would have to develop an active tracking sensor. I believe, and I remember stating, that if we had to take a sensor today, I'd be inclined to go with the ground-wind-type sensor. It's the only device that we've seen which is simple and has the ability to operate in the airport environment.

We still don't have one with out moving parts, and most of the fixed-axis ones that we've seen are subject to the same thing you saw up there -- icing. So, we must get back to some type of solid state anemometer. We've tried many devices in the wind tunnel. We've not found any of them that have been really effective in giving us the type of response that we want with the low velocity winds. But we feel that we can get there and that, too, can be done in a reasonable length of time.

There are many companies in the environment today that are looking at developing solid state anemometers. The Weather Bureau has been at it for several years and hasn't succeeded yet. But we've tried several devices. There are ones that use acoustic techniques, like the J Tech sensor. There are the Pitot-tube types. There are many different types of solid state sensors that are being developed and ones that can possibly do the job with a little more development.

We've tried three of them, that I know of, in the wind tunnel, and none of them have proven out yet, but I think we're much closer with that than we are with something like acoustics or lasers or those type of devices which are inherently complex and quite expensive, and when you start talking about a single device to do a total airport, those devices are not adequate. So, if you're talking about a reasonably expensive one and allocating it to the end of every runway, it becomes a very costly process.

The ground wind anemometers are not that difficult to implement nor that costly. So, we would probably lean toward the simple anemometer type, with the tracking algorithm in a computer to measure the output and positively detect and track that vortex.

We haven't come up with a solution yet as to how you effectively use it, and I think Joe brushed on that. About two years ago, I think, we were at the stage with VAS where we were going to add a safety device to the VAS which was really a group of anemometers to measure the vortex track as a back-up, so that if the vortex was still there we'd find it and say, oops, you've got to go around.

We never figured out how to use that device, because by the time you found out where the vortex was, looked at the amount of time it would take to communicate that information to the pilot, and got him to do something about it, he was already beyond where the vortex was. So, we dropped it, and we went with positive avoidance.

The VAS system will not allow impingement on a vortex at all. At that time we were considering the so-called, soft encounters, and we did away with that concept because we did not know how to implement it. But, again, looking into how you might implement such a system, it's probably feasible and some more work has to be done in the actual sensor development.

I hope that answers your questions, Sig. I'm not sure.

MR. WEDAN. Joe Tymczyszyn, Jr., made a suggestion that rather than go to the rooms tonight to get yourselves organized, that it might be a good idea to break into the three groups right here.

If you can find three available corners here, this might be just as adequate as going off to the rooms.

You know Joe is in charge of one of the sessions, and Guice is here, and -- Who's handling the third? Joe Stickle. Okay, Joe's up there in the back of the room. So those of you who are interested in the attenuation part of the problem, please orbit around Joe in the back of the room there.

Joe Tymczyszyn and his group here, if you people are interested in the problem, circle around him.

The rest of them over in this corner.

SESSION VII
STATEMENTS OF INTERESTED MEMBERS
OF THE AVIATION COMMUNITY

MR. WEDAN: Everybody, good morning, for a second day. I hope you had a pleasant evening last night.

Our speakers who have indicated the desire to make a statement, with respect to our Wake Vortex Program are at the table. One person who had been invited to give a statement was Vic Kayne from the Aircraft Owners and Pilots Association, He was unable to attend, but, he did give to me a letter, and I'll read to you the letter at the proper time on the sequence.

I'm not going to spend anymore time in preparing for this, except to once again, invite anybody from the audience who wishes to make a statement that might be of interest and help, particularly, to the workshop groups, that will split after this, please go ahead and let me know.

I'd like to invite Bill Codner, Air Attache for the British Embassy, to make an initial statement too, this morning. Bill, we know in the FAA and he maintains very close contact between the FAA and the CAA in UK. Bill, it's yours.

MR. CODNER : Thank you very much Bob. Ollie St. John sends his apologies for not being here. He was here in 1977 and enjoyed the conference which you held then. He's now the Chief Scientist in the CAA , and in fact, what I'm going to say today is from the British CAA.

For the past six and one half years, the CAA has been running a program which is specifically concerned with Wake Vortex Incident Reporting and Analysis, and the data which we have gathered has played a significant part in validating the elliptical algorithm which was developed by TSC and used in the VAS.

During this program, whenever a trend became apparent or a severe incident occurred, the UK procedures and separation standards were very rigorously reviewed by a group which included pilots, air specialists, scientists, and the air traffic controllers.

The most significant of recent events, was the world wide introduction of the ICAO Vortex Separation standards on the 10th of August, 1978. They were different in a number of respects from

the Vortex Separations which were then being applied in the UK and which we had developed during our previous years of the data taking exercise.

The evidence on the incidents is valuable but did not allow the UK to accept entirely the UK recommended separations. In certain cases, these would have, in fact, implied separations smaller than those which had emerged as adequate on the basis of the operational experience which we had gained.

There are three points, I think, which are shown in UK specifications here on this table. Notably, the **Medium** following the **Heavy** with a five mile separation whereas we have previously been using six, and we still in fact, use six, and the **Light** following the **Heavy** which is six in which we use eight, and then the **Light** following the **Medium** which would be four and which we have decided should be six, if the **Medium** in fact, exceeds a weight of 40,000 kilograms (88,000 lbs).

The separation for **Light** and **Medium** aircraft behind **Heavies** were considered in the light of our recorded **evidence** to be unacceptable and the rule was modified both by increasing the spacing and by changing the boundary between the **Light** and **Medium** aircraft from 7,000 kilograms (15,400 lbs) to 17,000 kilograms (37,400 lbs).

I think Joe Tymczyszyn, Sr., yesterday, spoke to the very wide range in the **Medium** area. These changes arose principally from the analysis of an instance involving the HS-125 aircraft which is around 11,000 kilograms (24,200 lbs). Under the UK rules before August 1978, the HS-125 had been classified as a **Medium** aircraft and was given a separation of six miles behind **Heavies**.

The recorded data shows that there was a disproportionate number of incidents, including one where the aircraft was reported to have rolled through 140 degrees when six and one half miles behind the Boeing 747.

By changing the boundary, the HS-125 would be classified as a **Light** aircraft along with a number of other small business jets

TABLE 1

SEPARATION STANDARDS FINAL APPROACH

Leading	Following or Crossing Behind	Spacing Minima (NM)		
		UK Pre August 78	ICAO	Modified ICAO
H	H	3	4	4
	M	6	5	6
	L	10*	6	8
M	H	3	3	3
	M	3	3	3
	L	3**	4	4***
L	H	3	3	3
	M	3	3	3
	L	3	3	3

where H - Heavy more than 170000kg
M - Medium 10000kg - 170000kg
L - Light less than 10000kg

) UK weight categories
) pre August 1978
)

H - Heavy more than 136000kg
M - Medium 7000kg - 136000kg
L - Light less than 7000kg

) ICAO weight categories
) from August 1978
)

H - Heavy More than 136000kg
M - Medium 17000kg - 136000kg
L - Light less than 17000kg

) ICAO/UK weight categories
) from August 1978
)

- * 8 from March 1978
- ** 6 if M exceeds 100,000kg
- *** 6 if M exceeds 40,000kg

and given a spacing of eight miles behind the Heavies. The rest of the medium category would then retain the established six mile separation standards.

The other significant factor in the new air-carrier standards has been the new level of 136,000 kilograms (300,000 lbs) between Heavy and Medium aircraft which the UK has accepted, but with some reservations. This means that the Boeing 707 moves in the Heavy category, thereby reducing its separation from the 747 from six miles to four miles, and because of our concern over this, we've kept a very close eye on the Wake Vortex Incidents Reports received from pilots since August '78 and compared them with the period January to August '78. This viewgraph give the incidents which have occurred on final approach at Heathrow to date.

There were 16 such incidents in the eight months up to August 1978, and 23 in the three months after the rules changed. Of all 23 incidents, 19 would have occurred under the old rules, and the apparent overall increase in the number of incidents is attributable to the uncommonly stable weather which we experienced in the autumn of 1978 as compared to summer.

At one stage during the summer, I had a letter from my father who said that this summer we have had a very mild winter, which sums up the English weather very well.

The other four incidents are to the Boeing 707's following Boeing 747's, and the spacing in each of these incidents was four miles.

In the six years prior to 1978, incidents to Boeing 707's following 747's when the spacings were five or six miles were very rare. There was also another incident not shown in this view graph, where a Boeing taking off one and a half minutes behind the 747 suffered a 40 degree roll at a height of 200 feet. If the 707 has been classified as a Medium, it would have been given two minutes separation and the incident either would not have occurred or it certainly would have been much less serious.

TABLE 2

VORTEX INCIDENTS ON FINAL APPROACH

10 August - 7 November 1978

Leader Follower	Heavy except B707	B707	Medium
heavy except B707	6(5)*	0(0)	1(0)
B707	4(0)	0(1)	0(0)
Medium	8(8)	0(1)	3(0)
Light	0(1)	0(0)	1(0)

() * = Incidents reported from 1 January to
9 August 1978.

There's also a penalty associated with the change to the **Medium to Heavy** weight boundary. Due to the increased spacing required now behind the Boeing 707, it's calculated that there will be a four per cent decrease in the overall capacity during the busy periods.

The UK policy is to insure adequate safety in areas of UK responsibility and this is decided on the basis of the operational evidence which we've been collecting, and of course, reviewing in conjunction with the FAA and TSC throughout the whole program.

The UK views on **wake vortex** separations didn't prevail in any case as it happens, on the weight classifications, and I think we heard yesterday, that there is some doubt in the minds of people that weight is necessarily the best way to classify. It just happens that at the moment, it's about the only thing we can do.

We're really consciously taking a cautious approach in the light of the experience which we've gained on incident reporting, and with the introduction of the modified ICAO criteria, we should be monitoring the situation with the particular care, especially the rules which are affecting the Boeing 707.

We are, of course, in close touch with the US regulatory authorities and with the US research establishments, and we hope that in due course, we will achieve a greater degree of commonality on the basis of all the evidence which we have collected so far.

You realize, from what I've said, that we really do question whether the 707 should be classified as **Heavy**. The data which we have collected since the introduction of the modified detail separations indicate that we had four incidents, where previously, we had virtually none. So, we're continuing to look at this situation very carefully.

We're also very interested in the operational evaluation of the VAS at O'Hare. Clearly, we would all wish to avoid a high over-shoot rate, and frequent changes of the rules must also be avoided. It, therefore, seems necessary to attempt to predict the wind situation over a significant period, say, up to about an

hour if the potential operational benefits are to be realized from the actual operation of this system in the operational environment.

This is a view graph of wind statistics statement at Heathrow. I don't know why it was 1974 or whether that was a very special year or whether it's the only one they could lay their hands on. I doubt if it differs very significantly from year to year, but it is clear from this, that the wind is likely to be outside the ellipse for more than about 50 per cent of the time. But, when you begin to predict ahead, the figure falls quite dramatically, and in practice, reduced separation standards arising from the operation of VAS, would probably be achieved for, perhaps, about 25 per cent of the time.

Throughout the program of collection of data on Wake Vortex Incidents in the UK, we've kept in very close touch, particularly with TSC on this, and as you heard yesterday, much of the evidence which has tended to validate the elliptic algorithm was obtained from our incident reporting system.

I'd like to just depart from the script, which I was given, to bring up some of the points which seemed to arise yesterday, and to question, perhaps, some of the truth which we seem to be faced with here and there.

I'm wondering if there's rather too much emphasis on the reduced airport capacity and delays when we're considering the effect of **wake vortices**. They don't occur only on final approach, and nor is that the only area in which aircraft were closely spaced. I think we were hearing yesterday that if you begin to separate aircraft more in the final approach, then this leads back further into the system. Should alleviation be pursued for safety reasons as well as for simply reduced separations on final approach.

Are **wake vortices** really creating a problem on arrivals and departures or are we in fact, faced with potential problems elsewhere and is alleviation really the only way to cure these problems.

HEATHROW WIND STATISTICS - 1974

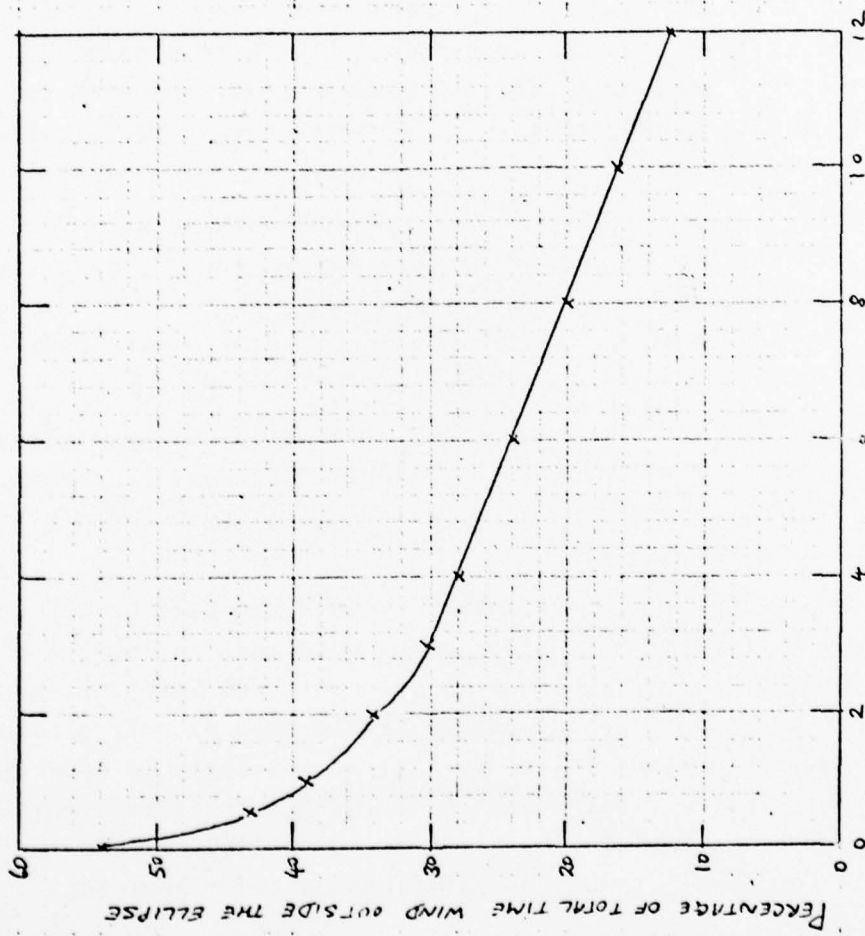

TIME (HOURS): WIND OUTSIDE ELLIPSE CONTINUOUSLY FOR AT LEAST THIS LENGTH OF TIME

Can the Air Traffic Control System, the controllers in fact, use the VAS in a real operational environment at the 20 busiest terminals. Will it significantly reduce longitudinal separation and consistently improve airport capacity, this is where I think we look with really great interest at the prospects of the evaluation of the VAS that are here. But, if the system doesn't give us the benefit at these 20 terminals, is alleviation the only other alternative, and if it is, how will it be implemented?

I'd just like to end with a short anecdote about examining truths, and this concerns the captain and the first major of a small ship with a small crew. The crew decided to have a celebration one night, and the first mate and a number of his other mates got very drunk indeed and the next morning the captain who was a stickler for seeing the truth in the ship's log, wrote in the ship's log: "Last night, the first mate was drunk," and the first mate was very upset about this, and realized that *this* would go on his record, and he pleaded with the captain to change this, but the captain said "No, and that's the truth, and that stays." The following night, the first mate was on watch, and in the log on the following morning there was an entry which was certainly true, but which was very damning indeed, it said, "Last night the captain was sober."

MR. WEDAN: Thank you Bill. I might indicate that we'll have a bit of time, I hope, after the speakers. I don't think we'll use up all our time indicated on the agenda, so, we'll have the speakers available at the table here for questions. Please feel free to question Bill if you have anything at the moment, or wait until the rest of them are through. I don't see any hands at the moment, so, as you think about possible questions, Bill will be here.

I think I speak for everyone in indicating how we appreciate the input from the UK, in fact, the international participation that we've had on this program has been quite good, and our second comment, is another indication of the same.

I'd like to introduce now, Wim Aardoom, who's a Project Leader for the Wake Vortex Program that's underway in the Netherlands.

MR. AARDOOM: Well, thank you. I must apologize for not having very nice slides with me, but we have had some reproduction problems. So, I have amateurish handmade slides with me, and I apologize for that.

The Netherlands, and in particular the Department of Civil Aviation and the Director of Air Traffic Services Telecommunications, got involved with the Wake Vortex Program approximately in 1976, after studies made it clear that research was starting to show results which could lead to the practical application of measures to reduce longitudinal separation in the final approach.

At that moment, and this still is so, Amsterdam Airport does not suffer from capacity problems. Progress in aviation in general is a very slow moving process. The anticipation of new developments (whether they are projections or operationally essential) must be considered in order to be ready when a need for the application of such developments arises.

It seems, at this moment, realistic to consider the introduction of the Vortex Advisory System. Plans exist today for only reducing the spacing behind Heavy jets as a first step to longitudinal separation reduction. In the light of this, together with the whole capacity situation, we set our preliminary aim at an operational VAS for the main runway at Schiphol for approximately 1981. They're planning to add one system a year to the other three main landing runways.

I want to make it clear here that if you look at the layout of the field, which is approximately six runways, it's almost hard to imagine that one has a capacity problem or can explain it. Unfortunately, due to all kinds of legal measures, normally only one landing runway is usable for the main stream, and sometimes, when weather and other circumstances allow, there is a second, but only for relatively small aircraft. Therefore, the potential of the field is fairly limited due to this environmental loss.

Another point was taken into consideration. Schiphol's circumstances would allow, it seemed at that time, a possible separation reduction approximately 75 per cent of the time.

The question at that moment was to reach that goal. What was basically required was a set of meteorological towers to verify the ellipse with Schiphol's circumstances. You must have means to sell it. So, obviously, we needed a detection system as well to collect sufficient data for this purpose.

The choice was then logically made in favor of a set of wind anemometers, which seemed to be most promising and hopefully still are. A single test system was set up with wind anemometers, to see whether the size of the anemometer array is suitable.

While collecting data for this purpose, a couple of other possibilities of using this data appear, such as, dealing with the way wake turbulence categorization and related separation criteria (as they are now described in Docket 444 in Annex L) act to increase airport capacity even further. A lot of confusion about the 170-ton definition of Heavy has risen; now the 707, DC-8 and the Airbus are included as Heavy. We have doubts about this, and this is a problem that has to be looked at and we hope that all the data available will finally lead to a very critical review of the present material.

There remain two main objectives which can be summarized as follows.

The first one is to collect data on behavior in general with the objective to find the correct tiering for separations behind all aircraft. I must admit hoping and expecting that these will show a strong similarity with present results and that they can be more or less considered as a confirmation for our environment.

The second objective would be for experience and later on for an operational system.

If I might spend a few words on the system itself - maybe it's a little bit out of the scope of this meeting, but might be of interest to some of you.

The system itself is assembled by and is designed in close collaboration with the National Airspace Lab in the Netherlands. It uses wind velocity information from nine vortex anemometers and seven wind sensors in a similar set-up as used by TSC at John F. Kennedy Airport.

The arrays are 400 feet long including the 300 foot window length. They are mounted approximately 450 meters from the threshold. The remaining equipment is set up in a caravan nearby.

The hardware concept is straightforward and consistent with using the components which I've shown in the slide. There's a data acquisition system which is nothing but an analog filtering and analog-digital conversion. There's a Nova III Mini-Computer and the only reason for choosing this type is because we have experience with this type of computer. Then, there's NPXTMA Metrek tape recorder added to it. There's an equipment monitor for two reasons.

Number one, to have a quick look at the data assembled and to see what comes out. The second reason is to give some visualization to the operator of the system. The possibility would be to show some kind of pictures to him, but, then, the operation might fail. The teletype is used for inputting mainly aircraft type and other data.

The main outputs of the system are, in some aspects, a little bit ambitious. Provisions are made to record on tape the Romex Center Data, the Vortex Center Data, processed wind velocity, direction, gusting, and Vortex positions as estimated by a number of filter algorithms. We plan some extra effort to see whether we can come a step further to real time tracking, vortex residence times, aircraft type, meteorology data and the status of the system.

To quickly monitor (shown on the next slide), - I had some photographs transferred into a slide but unfortunately, that failed. What you see there are vertical thermal meters, if I might express it like that. There are 15 kinds of thermal meters displayed

AD-A077 897

TRANSPORTATION SYSTEMS CENTER CAMBRIDGE MA
FAA/NASA PROCEEDINGS WORKSHOP ON WAKE VORTEX ALLEVIATION AND AV--ETC(U)
OCT 79 W D WOOD

F/G 1/2

UNCLASSIFIED

TSC-FAA-79-77

FAA-RD-79-105

NL

4 OF 4

AD
A077897



END

DATE
FILMED

1-80

DDC

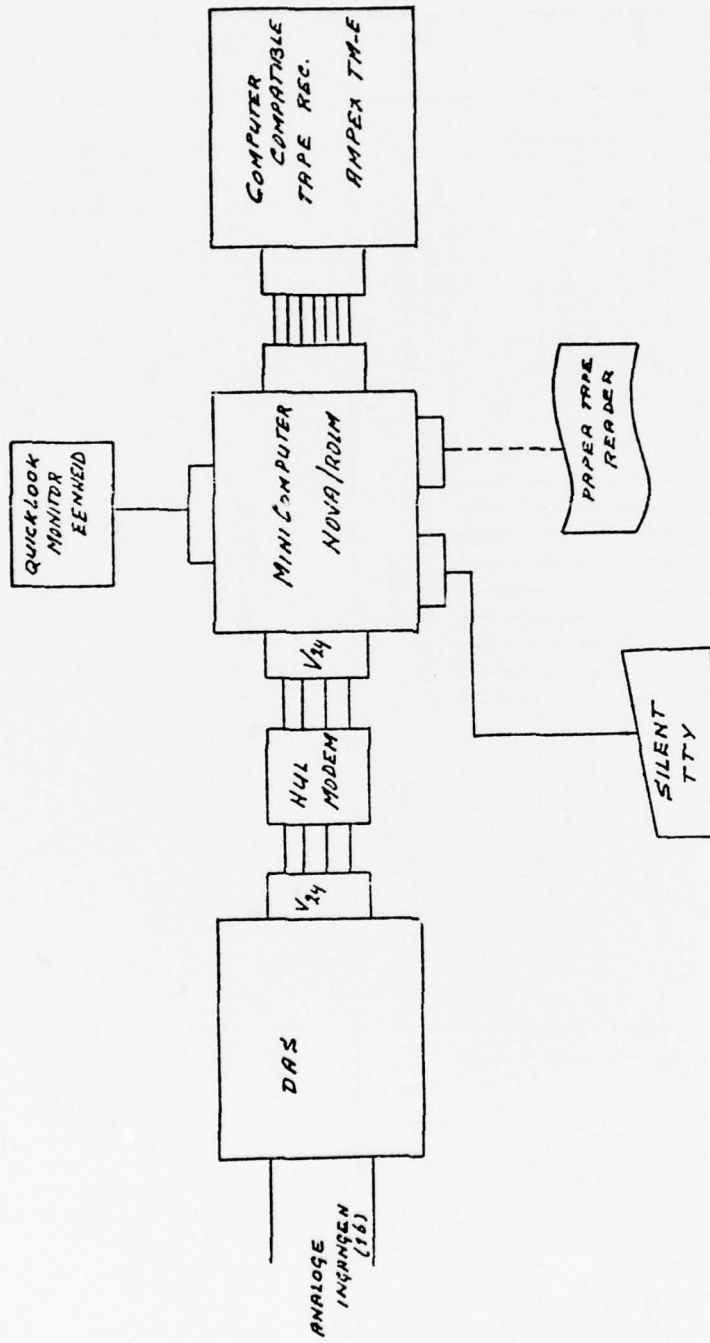

SYSTEM CONFIGURATION

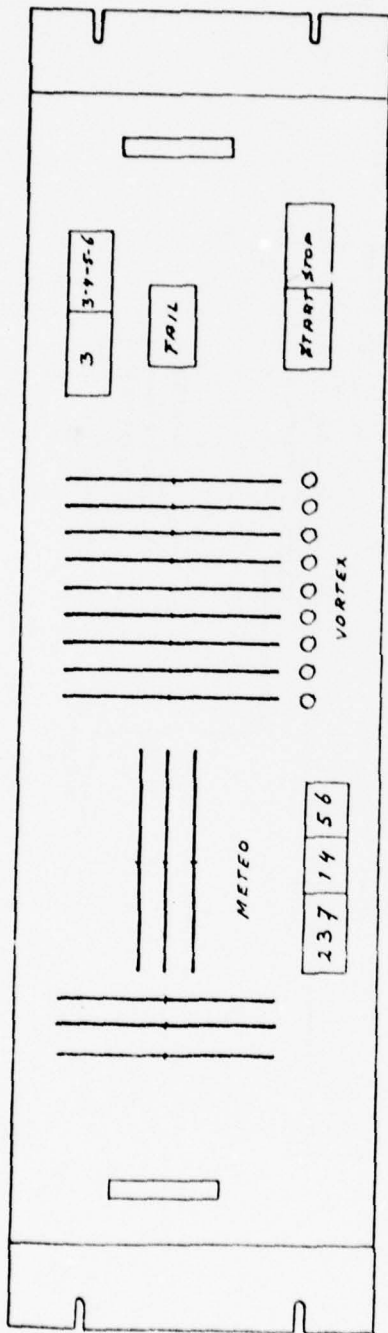

QUICK LOOK MONITOR

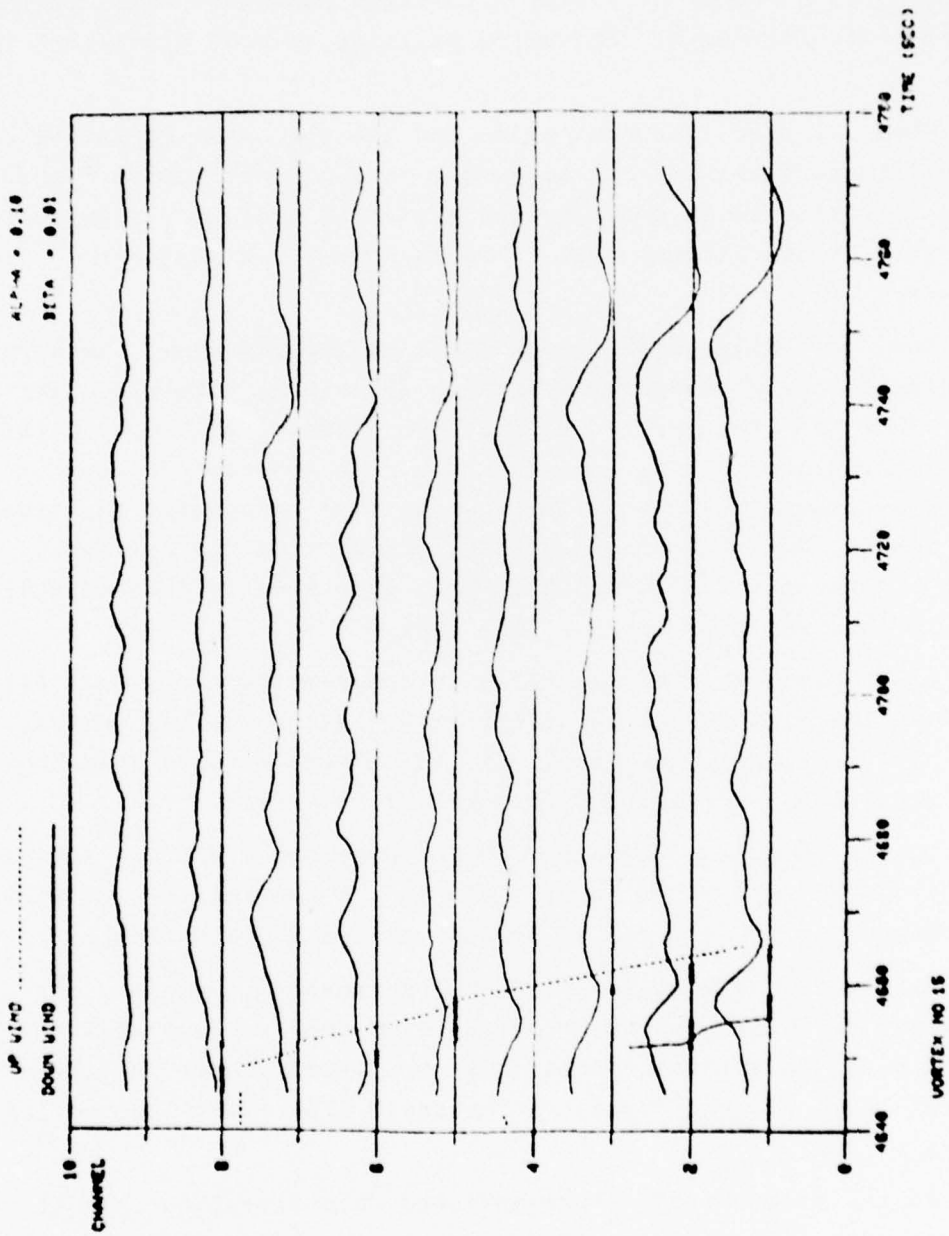

to indicate the output of the Met and Vortex sensors. Then there are some vertical thermal meters indicating vortex position as estimated by a number of filter algorithms, and as I said, this is optional for the moment, but we're starting to make provisions for this.

This is a failure indication and the optional separation criteria; the green and red lamps are on top. Obviously, I must state that this is an experimental system, there's no intention to make this an operational one. This is only for experimental purposes.

Now, if I might spend a few words on the planning. We were planning for an operational system in 1981-1982, something like that, just to set a goal. In 1976, the planning was to have this experimental one working on April 1978. We experienced serious delivery delays in the computer and the tape recorder. This took nine months, and after they were delivered, they did not work, which cost another three months, which were unbelievable things, really. So, we lost, in fact, one year.

At this moment, the system is in the very last phase of hardware testing, and the application system and the analog analysis programs are almost completed. At the moment, we have good hope, that we will have it working in April of next year.

Due to this, the planning for an operational VAS now indicates 1982 or 1983, as a first step. This is all preliminary, of course, and depends on the outcome of the evaluation of this thing.

By the way, I want to use this opportunity to express our gratitude to the FAA and TSC for the time they've made available in the past, on different occasions, to discuss their research programs with us, and demonstrating their experimental detection system at JFK.

In the light of the aforementioned objectives, our result will be made available to interested parties, including, of course, FAA and TSC. Thank you.

MR. WEDAN: Thank you very much for that report and I think we're all looking forward to seeing results the next time we get together, the results of the system test. Any questions developing so far? Well, if not, I'd like to move on to the next point.

For those of you who have been following the agenda, you may have noticed that I've been working from the bottom up. I'm not going to give you a reason because I don't have one, but, there were a number of invitations that went out to the so called using community, one of which is the Aircraft Owners and Pilots Association. As I indicated before, there was a problem in their ability to attend this session, so, I would like to read to you part of a letter I got, which indicates the AOPA position.

"Our position has been stated a number of times and is repeated here to further get it on the record. We consider Wake Vortex Detection for purpose of Avoidance to be a stop-gap measure. When **wake vortices** are detected, it is necessary to increase separation between aircraft and this adversely affects runway capacity of acceptance rate. There also is a related factor regarding liability. If the detection system is in operation, and the pilot is not warned of vortices, and the subsequent accident occurs due to the vortices, the FAA will be found liable and receive resulting damage suits. With so much effort being expended on increasing runway acceptance rate and capacity, the obvious answer to **wake vortices** is alleviation.

This also is the answer to related safety problems. Thus, the main effort in this field for the long haul should be in field of alleviation or elimination of dangerous wake vortices. This will enhance safety and, in addition, will restore capacity to airports now suffering from extended separation for the purpose of increasing runway acceptance rates and capacity.

We hope that your workshop will concentrate on ways and means of effectively eliminating dangerous wake vortices at the source. We cannot add to the deliberation, in this respect.

Thanks for the invitation and an identical letter is being sent to Mr. Ken Hodge of NASA. Sincerely, Vic Kayne, Senior Vice President, Policy and Technical Planning."

Any AOPA members that would like to stand by for questions in this area, we'll put them to you.

Another organization that has been invited to make a statement is the Airline Pilots Association: We have two members here today, Captain Joe Davies is with Ozark Airlines and Jack Howell, who we've heard before from Eastern. He is a member of the ALPA Safety Department.

Who wishes to speak first? Okay, Jack.

MR. HOWELL: Thank you, First, I'd like to address the VAS Program that will be in use next year at O'Hare. Secondly, I want to talk briefly about the alleviation methodologies that we learned about yesterday.

I want to touch on WVAS also and lastly reduced longitudinal spacing.

Back to VAS, the first thing I want to say about that is, that I, as an airline pilot, welcome VAS and the technology it brings with open arms. And, the reason I say this so clearly is because for the first time I will know I have wind information in the landing touchdown zone. This is what I've been after for a long time ever since they started removing windsocks from the end of the runway.

Moving on from there, which is the highpoint, I suppose I can learn to accept three mile spacing at the middle marker. Being a creature of habit, it will be a process that can come over a period of time with experience and also with education. But, down at the other end of the spectrum, I must admit I'm very

pessimistic about the success of the VAS programs scheduled for O'Hare. The reasons are quite simple, to date I have seen no evidence of an adequate Pilot Education Program and yesterday I saw slides that said that simulation assumed wide-spread pilot acceptance. I do not believe we will have wide-spread acceptance without an education program.

To illustrate why I feel this way, picture this. Here's a crew coming into O'Hare. It's snowing, they are very near diverting because of fuel. The captain has just moved over from the right seat, the engineer has just come off the panel after eight years of stagnation in the second officer position, and all of sudden when they pick up the runway lights, they see a 747 ahead of them and they say. "My that guy looks awfully big, what is our spacing," and so they ask, "What is the spacing?" He says three miles and to quote a phrase from a magazine that we all know, "I learned about VAS from that." I think his immediate reaction will be, I want five. We take that gentleman, we put him in the peak workload condition, and on approach to O'Hare, loading him up with a few other factors, and at that point, introduce him to an experimental program. I think that's wrong, and any man who has that initial exposure to VAS will reject it. If the program starts out with such a backward step, or a black eye, word of that kind of operation will spread throughout the pilot community much faster than a positive word might. So, I urge the FAA, Transportation Systems Center, and those who want to see VAS work, to get busy on a Pilot Education Program right now.

Secondly, a brief comment about alleviation. I too have a question about the liability of a vortex. In October, there was an incident in San Juan where a light twin underflew a Heavy, subsequently, the twin crashed with fatalities. Right now, there is a lot of effort going on by some people to try to attack the Heavy as causing the Light airplane to crash. So, how the Light aircraft got to where it was at the time during the approach is a very interesting story, but nevertheless, the liability factor for a vortex must be explored.

With respect to alleviation, I also have a worry that if we were to achieve reduced longitudinal separations along the final approach path, what will be the pilot reaction to an encounter somewhere in the terminal area? Assume he's in the terminal area, and we have VAS working, and it does have some degree of acceptance, if a fellow finds a vortex outside the marker, will he accept what the VAS Program can provide for him on the leg of the journey from the outer marker inbound?

Also, with respect to alleviation, I think, this period of time, when we see the airlines in a scramble for routes, scramble for aircraft, new personnel and lower fares, you probably will encounter managements which are not willing to discuss, too seriously, at that point in time, additional cost items for each and every landing approach.

WVAS - quickly a comment here for shopping for sensors, I would like for each of you to reconsider the benefits of an onboard sensor. We would take it to all airports, we would take it internationally, and would it be ludicrous to ask a question, "Can a single sensor be developed which could see wake vortices, wind shear and clear air turbulence?"

Lastly, my thoughts on reduced longitudinal separations. It's not just a wake vortex problem as we heard yesterday from several of the other gentlemen with an operational background, but it's a collision avoidance problem. The conflict alert thresholds have to be adjusted. When occupancy times are a factor, and we haven't even yet as an industry agreed on a friction measuring device. Also, ALPA has for a long time, believed that active pilot participation is an important goal, especially, if we're going to consider reduced longitudinal separation, and of course, the other land side problems that were talked about.

I think what we really need is more airports. I know, we've all said that before, but I think in recent years we have rolled over and played dead far too easily for the environmentalists. There's no better time than right now to get started selling

aviation. Ridership is on the incline, and more and more are coming to benefit from the good of aviation.

I think we ought to blow our own horn a little bit. Thank you.

CAPT. DAVIES: I'm a non-technical person, I don't know how you got inflicted with me.

When I was listening to the people giving their papers yesterday, I was reminded of the statistician who drowned in a lake with an average depth of six inches.

For some of you, O'Hare's my baby. I couldn't tell you much about Kennedy of Boston or Zurich, but O'Hare, the biggest airport in the world, is my home. You actually have two airports there, a north and a south airport; they have separate frequencies and are actually operated as two airports. That's how they can handle all the airplanes. We actually land on three runways and take off on two simultaneously, which was scary when it started but we learned to accept it.

We've had our first 3,000 movements in one day, and that's every 28.8 seconds either somebody has taken off or landed. I doubt very seriously if you're going to improve on that. We also had our first day when the O'Hare computer locked up. They put so much data into it that the memory banks, physically, ceased to turn. The cure for the problem is a long-range deal where you have to extend the memory. It's not something we can do very easily, you're going to plug in a lot more paper and a lot more wires. The cure to the problem is that somebody goes down and takes some of the data out, so that the computer will accept data from Chicago Center again.

O'Hare's getting to the point where I feel we should really consider, as Jack says, landing someplace else for a while.

There's another thing that I feel might have been overlooked, and that's Vortex Encounter Reports. I doubt very seriously if more than 10 or 20 per cent ever get reported. If you go out, and most of us will be going out on a commercial carrier, stop that

crew when they get onboard and tell them you're going to give them two-mile separation at the end, and see what they say. Did they ever have a vortex problem and if so, did it ever throw them over. It doesn't have to be a Heavy, it can be a 727 or some other aircraft and give you a pretty bad ride.

I'd like to also point out about O'Hare. We're handling more airplanes at O'Hare now than we did before there were heavies. I'd like to go on and point out that I think this system is going to be extremely hard to sell, and I feel the more lead time that you give to the airlines to put it into their ground school the more quickly it's going to be accepted.

I got the opinion yesterday, right or wrong, that its just about completed, that you have the programs and now it's going to be operated, the system is all in. I would love to see an announcement by December 15 that it's going to be fired up on April 1, May, June, or August, or whatever you want to do, so that you got more than this 45 days. A note to the pilots and they read the initial file, cannot cover all the data that was put on the board yesterday. The ten years of experience that you've got with this system, collecting the data, or the system has actually been monitored for two years now, or something. The airlines will put it into their ground school, I can't speak for General Aviation or whether they will disseminate it like the Business Pilots Association. They have their problem there too, and it's going to be much more difficult to get all the corporate pilots that are scattered all over the United States into this program, but, I would sincerely feel that you should give them more time to know that this was coming.

I also foresee two airplanes on the runway at one time. We shoot regular minimums now to O'Hare at 1800 RVR and if some guy doesn't turn off right, he's going to be down in the soup away. That, of course, is one of the big problems I have with Category II, that is that you can't tell me the runways are clear, and I can foresee us going back to where there are three airplanes between the outer marker and the airport. Well, for the non-

flying, that's going to be difficult to understand, but that puts a pilot right on the edge of his seat, there'll be a guy over the outer marker, there'll be somebody touching down. If one guy blows it, the guy that's touching down doesn't clear the runway, the guy in the center doesn't slow up quite as much as you expected, it's going to be sticky, and what happens when the guy goes around, is going to become a real serious problem.

I'd also like to point out, and I guess this has all been thought through, that it was pointed out that the spoiler deflection cut down on the vortex, and I won't question that at all, and it was also said that it was going to increase the cost about \$2.00 a landing.

Based on information I have on our carrier, which doesn't have a Heavy, that could cost a big carrier with a lot of Heavies in the neighborhood of a quarter of a million dollars a year, and I know that ATA is going to be very upset with that.

Well, thank you again, for allowing me to speak to you.

MR. WEDAN: Any questions at this point?
Yes, we have one here.

DR. TYMCZYSZYN, JR: I just wanted to answer some of the things that Jack and Joe said. It's very true that we have not started a training program with the airlines yet. We've talked with the ALPA people at headquarters and with the safety people and to the airline management, but we haven't gone out to the line pilots.

The main reason for that was that we haven't proved the safety of VAS to our satisfaction until quite recently, so, there's no way that people like me or Hallock or anybody else is going to go out and start telling line pilots, or have the airlines tell the line pilots that they ought to fly three miles behind a heavy 747. If we weren't sure ourselves it was safe it would be pretty hard to sell skeptics on something that you are not even sold on yourself. So, we had to wait until this point, to start.

Now, on November 2, we met with the airline chief pilots that operated at O'Hare. We talked to them about what would be necessary for them to get their pilots going on it. They said they would need a minimum of 45 days to educate their pilots.

We're planning to give between two and three times that much, so, instead of starting in mid January (which we could if we announce December 1) we'll probably wait until April 1 to start VAS, so, the pilot education time would be December, January, February and March, and I agree that we have to fire up our pilot education real fast on that, and, it will be the Airline Managements, and not the FAA, that will educate the airline pilots. The FAA will provide them with the film that you saw yesterday, and technical briefings or people to be present as necessary and we'll provide ALPA with any material they need to put articles in their magazine or ALPA briefings and so forth. ALPA wants to get out the fact that if you don't want to participate in VAS, you don't have to, and we're going to stop VAS immediately if there is an incident and investigate it.

The next thing, Joe mentioned business pilots in AOPA. As was said yesterday, light aircraft are not going to participate in VAS. We haven't proved that safety at this time, so any Light aircraft are going to have the same separation that they have always had, so, there's no particular need to educate them, at least, not now.

For the business aircraft that are in the Large category, 12,500 pounds and above, they will be in VAS and we have to get the word to them. It's a lot harder to get to the business aviation community than to the airline community, but we have things like the Airman's Information Manual and that will probably be our primary way of getting to that segment of the pilot population. As you saw yesterday, the business aircraft over 12,500 pounds at O'Hare are probably 110 per cent of the total aircraft into O'Hare. That's all.

MR. WEDAN: Thank you Joe. Any other comments? Questions? Okay, before introducing our last speaker for the session, I'd just like to take a moment to remind everybody that

while we are in this process of getting a system up to an operational status and concerning ourself with such problems as education of the pilot I would like to add the controller community.

One of the prime purposes of this get-to-together is to recognize that we've achieved significant progress in creating a ground base system, and there's been significant work done in the area of vortex alleviation at the source, particularly through the spoiler deflection technique.

We have the problem of what do we do now, where do we go from here? That, again, I hope our workshop sessions will address very seriously. Now we did hear a paper yesterday and several people made the comment that we're working a problem, but who needs the answer - the people from the industry? The air frame industry has said that if they contacted the airlines about putting modifications on their aircraft, whether it's retrofit or new designs, there's kind of an uncertain attitude about the need for them. The suggestion here is, perhaps, what is the motivation for moving ahead. The next step ought to come from the Air Transport Association or the airline industry.

I hope Frank Brady might be able to shed some light on that part of the question in the next few minutes, Frank.

MR. BRADY: Thank you, Bob. I don't know how deeply I'll get into that particular question, there are some competitive forces involved, and some of these things that we can address and others we cannot address, but, anyway, I would like to give you as much of the airline view as I've been able to assemble.

Aside from safety, delay holds top priority as the number one operating problem of the airlines today.

Delay causes massive inconvenience to the public and is exceedingly costly to the airlines. In the single month of December 1977, the air carrier delays added up to 22,898 hours one month, a total of 4,875 aircraft were delayed over 30 minutes. Cost to the traveling public in 1977 was estimated to be three hundred million dollars. And airline losses attributable to delay

added up to well over two hundred million dollars, there's a total of a half a billion dollars in one year.

Put in terms of a single aircraft, one airline has determined delay costs of a 747 to be more than \$46.00 a minute. The same airline estimates its 1977 delay losses to be over fifty million dollars, single carriers losses, fifty million dollars. The 1977 fuel waste for the industry caused by delay amounted to three hundred and fifty million gallons. For these reasons, the airlines are vitally interested in cutting delays from all causes.

Because our record keeping is imperfect, we do not know what portion of overall delay is attributable to increased spacing between aircraft because of wake vortices. We do not know however, that it is a substantial contributor even though it is limited to a view of our high density airports. The increase in longitudinal spacing between aircraft has caused a marked reduction in airport capacity. It takes only simple arithmetic to determine that an average increase in spacing from three to five miles reduces runway capacity by 40 per cent during those hours when the airport traffic demand exceeds the saturation point.

Six airports, O'Hare, Atlanta, Kennedy, LaGuardia, San Francisco and Los Angeles have in the past accounted for nearly half of all US airline delays. Saturation at these airports is forecast to increase further and the FAA has predicted seven additional airports will suffer increased delays.

Excessive spacing between aircraft dictated by wake vortices is an important contributing factor to the delays at these airports. If effective relief is not provided, this list of airports will grow and the number of hours of saturation at each airport will increase and compound the problem.

Now recognizing the seriousness of the problem that it is facing, the operations executives of the airlines have endorsed the following statement, and I quote. "The airlines should press as a matter of highest priority for the solution to the excessive spacing between approaching aircraft. Efforts should include both

ground based systems for detection, such as the Vortex Avoidance System and development of aerodynamic suppression of vortices on the aircraft itself."

This airline attitude and priority on wake vortex has been conveyed to FAA and NASA many times and at many places, it's also been conveyed to the Congress. Wake Vortex Avoidance and Alleviation Programs in both agencies have been strongly supportive, and we're not aware of any shortage of funds to carry out this work. At the present, I hear signs that at least there might be a pinch coming, but, at the present time, there are funds for the work.

Nevertheless, the FAA Program has been delayed again and again since 1970 when FAA initially announced increased separation standards behind Heavy jets.

After some vigorous prodding by the airline industry, the FAA in 1972 announced a five year plan to cope with the problem. The goal was to have a test system operating at O'Hare by mid 1974. The completed system was scheduled for mid 1975 and was to be integrated into the ARTS III by 1976.

I will spare you all the details of the slippage, revised schedules and mountains of data collected, but we are still waiting for operational test results of the program. At this workshop, we are getting a better idea of how soon that's going to happen. It is probably unfair to say that the program has been mismanaged. It's now clear that there is a far more complex problem, than was originally anticipated. I think the complexity is not one of technical complexity so much as it is the responsibility, the procedural aspects, and all that. I'm talking now, of course, about the ground system.

There is also some indication that the FAA may have gone a little overboard in analysis and testing, this thing has been tested and tested and tested. You can't have too much of that, but on the other hand, you have to cut it off at some point and go to work.

Wind Shear Detection has moved much more rapidly than the Wake Vortex Detection, and Low Level Wind Shear Alerting Systems are now in place and operational. These systems have similarities, and there's an excellent opportunity for some common use of certain components that will allow economy of installation.

Unfortunately, unless the integration of the two systems is speeded up, most of the programs wind shear systems will be operational before installation of the Wake Vortex System is started. The airlines have long pressed for compatible siting of sensors and an integrated program.

Though I have talked about the lack of detailed delay information there is a growing airline recognition of the need for improved methods of evaluating system performance as it relates to delays, and fuel waste and system capacity.

Some excellent analytical tools are now available but they need better input information to assure that the findings are valid. FAA Programs, such as Real Time, ATC System Performance Measurements, and Uniform Delay Reporting are promising as a means of obtaining valid data and as a means of pinpointing problem areas. The Data Collection Programs now under development by FAA, should go a long way towards getting the needed data.

It should be noted that any attempt to automate the terminal Air Traffic Control must take into account the variable spacing requirements imposed by wake vortices.

The metering and spacing system of the future must include adaptive separation to realize the fullest potential of its use to increase airport capacity. On a long term basis, the most attractive solution to the wake vortex problem would be to eliminate the generation of vortices at the source. I think this is a very obvious conclusion, and this has been brought out time and time again, here.

From the time the problem was recognized early in this decade, the airline industry has actively encouraged research and development programs towards this goal. The problem is a difficult one,

and even the expenditure of over ten million dollars in NASA R&D funds, or whether they were FAA funds transferred to NASA, from 1972 through 1976, has failed to produce, at this point, an acceptable solution. Each of the schemes tested thus far has included penalties in aircraft weights, speed or fuel consumption. It's particularly disappointing that after the extensive NASA work, we have seen no evidence that the results are showing up in the new generation of transport aircraft. Now, I realize in saying this, that this conference is saying, well, the airlines have not asked for it. However, the airlines have indeed asked, and as I said, many times and many places for solutions to the problems. The problem is one of getting an acceptable package, a prototype solution, and that I think, is a matter that's going to have to be worked out between the air frame manufacturers and the airlines, and I think that the time has probably come for that to be done.

It will be disappointing, however, if the new generation of aircraft do not benefit in some way from the work that's been done in the past.

Now this approach is admittedly a long term solution, retrofit of aerodynamic devices on existing aircraft is difficult and also expensive. Computer programs of existing control surfaces may offer an attractive solution where the flight control system is adaptable to such modifications.

In any case, significant ATC improvements from the alleviation of wake vortices at the source will take a very long time to achieve. Nevertheless, it would be reassuring to see more activity in this area.

The amount of delay caused by wake vortices and the impact on airport capacity is quite sensitive to the designation of Heavy, Medium and Light categories of aircraft. Joe Tymczyszyn, Sr., and Bill Codner both spoke at length on this subject.

We note that a MITRE Report issued in March of 1976 analyzed this problem, and concluded that a shift in the dividing line between Heavies and non-Heavies from the current three hundred

thousand pounds would yield a capacity increase of roughly three to six per cent at major airports, such as Midway, O'Hare, Los Angeles, and JFK.

This change would have the effect of placing stretch versions of the DC-8 and the Boeing 707 in the non-Heavy category. Such a potential increase in capacity is attractive, and indicates the importance of a careful selection of the dividing line. My point is not that the current rules are wrong, but that an arbitrary selection can have a major effect on airport capacity, and as it has been pointed out, it should be studied and if there's an opportunity there we should take advantage of it.

There's a point, most of the emphasis has been on alleviating the effects of wake vortex on aircraft approaching the airport. This is only part of the problem, and we would urge increased emphasis on improving take-off clearance rate, because this too can contribute significant amounts of delay and can have an important effect on airport capacity.

My recommendations, at this point, would be to first wrap up the test program as soon as possible. There should now be adequate data upon which to proceed with an operational program based on a ground base system.

Second, set a firm date for the start of VAS operation, and hold to it.

Third, place increased emphasis on improved take-off clearance rate using techniques similar to those on approach.

Four, expand procurement and installation programs to include those airports where peak hour saturation is a problem now, or is expected to be a problem in the near future.

Five, continue work on the development of improved sensors.

Six, examine criteria to determine if the dividing line between Heavy and Medium aircraft is overly conservative or whether it is optimal or not.

Seven, improve data collection on air traffic control delays to determine, more specifically, the causes of delay and to identify that portion attributable to wake vortices.

Eight, accelerate programs to develop satisfactory prototype systems for wake vortex reduction on new aircraft and transfer the technology to aircraft manufacturers for new generation aircraft.

Nine, integrate for a possible wind shear and wake vortex system.

Ten, above all, let's make decisions on reduction of separation in those areas we already know are safe.

MR. WEDAN: Well, there we have it. Okay, now, by this time perhaps, something has occurred to you that you'd like to talk about before we break into our workshop sessions.

Joe.

MR. TYMCZYSZYN SR. : I'm not going to let my son beat me to the punch. Yesterday, when he shut me off, I had two important items on that list there. One was item 12 or 11, it was an airborne wake vortex detector, and I think we don't have a certain segment of the aviation community represented here and that's the electronic people who make little gadgets that help make our life a little easier.

In the course of doing the testing for wake vortex strength and alleviation, we asked people working on the data, if we couldn't have something in the airplane, in the test airplane, to help us find a vortex. Now, we have developed the system where the people on the ground can tell you, that yes you are in the center of the vortex, you are in the core, or you're approaching it rapidly. Now, from a pilot's viewpoint, believe me, if you can hear the vortex coming, particularly an unalleviated, strong vortex, where you have a fine nice size tube with very high velocities, you can hear it approaching. It's sort of a dull whistle. You can hear it, even through your crash helmet. Then you reason, "Why in the heck can't we have some electronic equipment in the airplane to help us find it."

Russ Barber in the T-37 that we have at NASA, had put on the first attempt. That was a bread-board model of these tiny little tubes on the wing tips of the T-37 with little acoustic sensors in there, sweeping through the acoustic range, and a little needle saying it's left or right.

Since we only carry 20 minutes of smoke in the 747, 1011 or DC-10, every second of test time is precious and you dedicate that to ways of working on a basic problems, and not on perfecting such instruments.

We have been trying to alert people to the fact that an airborne **wake vortex detector** may not be too difficult to work on, and I'd just like to bring out in this workshop, the fact that there is some potential there, maybe we're not the right people to be working on it, but, there ought to be someone interested in that particular phase. Thank you, Bob.

MR.WEDAN: Thank you, Joe.

Jim.

DR.HALLOCK: First of all, we have issued a report from TSC by a contractor, where we have looked at the airborne **wake vortex detection**. I think I have some copies in my office if someone wants to look at it.

Secondly, some general comments. The results we've been getting from our friends in Great Britain from their incident reporting system are very, very valuable to a person like myself because we're really getting to understand what's going on in other phases of flight.

Question: My question to Jack and Joe is how come we're not hearing much more from the NASA Incident Reporting System, the Safety Reporting System, about these incidents? Has it become such an everyday occurrence that you don't report them or what?

Answer: (By Jack Howell) I would have to agree with your answer to your own questions. The reasonably common occurrence is to get a nibble now and then. It would only be the violent upset that would be reported to the NASA System, which brings me

to a question that I made in my notes yesterday. How are we doing for time?

MR. WEDAN: We are doing fine.

MR. POWELL : I guess the question when somebody says, "What is an unacceptable encounter or an acceptable hazard?" Well, I needed a definition for that. My way of thinking of an unacceptable level of encounter is anything that would cause you to miss the approach, death being at the other end of the scale and extremely bad. But, I think that's the kind of thing we ought to look at when we're assessing probabilities and encounters etc. If it is a break off of the approach, that's the level at which I think we ought to set our goals. Now looking at Safety Analysis: With respect to your first question, I agree, I think there are nibbles that you get on final and you just know what they are, and you move out of the upset, a little bit off center, however, using whatever other visual conditions to get out of the encounter.

MR. BARBER : Russ Barber, NASA. Really, my question goes to Joe Tymczyszyn, Jr. The concept of the VAS is all predicated on no encounter, in fact, he said several times, if we have an encounter, we'll knock the system off and start investigating it, immediately.

I fail to understand the logic, then, of why it's not safe for general aviation if it's safe for transports when it's totally predicated on zero encounters. I wonder if he could elaborate on that?

Answer: (By Joe Tymczyszyn, Jr.) Well, I want some help here from Jim Hallock, too. I see what you're saying there. It's not totally a zero encounter, it's also the fact that it's okay for a 727 to hit a very weak vortex, but, it's not okay for maybe a PA-28 to hit the same vortex.

Jim, do you want to handle it.

Answer: (By Jim Hallock) I think I understand the statement that Russ made. It really is going to be safe for both the GA and the commercial airlines according to all the analysis that

we're seeing. We do have a couple of basic problems that we want to look at, before we go all the way, because of the way the analysis was done. But, yes indeed, it should be safe for both of them. There is no question, because we're not talking about a non-encounter. Given the conditions, our green light conditions and so on, everything seems to point to everything being fine, no matter what you're flying. However, just because of the way the analysis was done, the mathematical approach one takes to it, we can't absolutely say that yet because of the philosophy of the mathematics.

DR. TYMCZYSZYN, JR: The way Flight Standards is worried about the safety, we're looking to TSC for the safety analysis, and what they are willing to support is safe, if we buy off, but, if they won't come to us and say that we've been able to show that it's safe, then we're not going to say it is, so they haven't been able to support fully the safety of the Light aircraft, so we are not going to include them.

Another reason we're moderately happy about starting, without including the Light aircraft is the problem that if you don't have a glide slope on your airplane, you can't participate in VAS because you hit the outer marker, descend on down to MDA, fly level and be set nicely for a vortex encounter. Now, we planned to get the word out through Airman's Information Manual, and whatever sources we have, that if you don't have a glide slope and you are going to use a localizer only approach, you've got to tell the controller, you have got to announce it's a localizer approach, and that you would be given the larger separations of today. Frankly, the number of people that read the Airman's Information Manual is not very encouraging, and we might have problems. It's easier to start with the airline community where they have dual glide slope and a much better training program to include general aviation.

To change the subject, it looks like we've come full circle on the chicken and the egg problem. Let me misquote about people, I'll probably mix it up, but will show the chicken in the egg problem.

Frank Brady said that the airlines are very interested in alleviation and that they are disappointed the alleviation isn't being sold on the next generation of aircraft. The airframe manufacturers that we heard from said that they have received no expression of interest from the airlines at least, not in terms of people ordering airplanes and being willing to pay for alleviation. NASA said that FAA has treated alleviation with, I think Al's words were benign neglect, so, they are going to pull out their money after this fiscal year; and for the FAA, I said that I didn't think a notice of proposed rule making, requiring alleviation, would have a chance of floating in the industry because the airlines and the aircraft manufacturers would shoot it down during the comment period. I think we have a pretty good definition here of the chicken and the egg problem where nobody wants to make a move on alleviation, and I think that's one thing we'll have to address in our workshops.

MR. WEDAN: Thank you, Joe. I did hear very clearly here, Frank Brady indicating the views of the Airline Transport Association, that there is an urgency to move ahead. There always has been an urgency to move ahead by the airframe manufacturer to develop alleviation. I think that's point ten in your ten points or so, so I'm wondering if the egg is being split open and the chickens about to appear.

Phil, did you have a question?

Question: (By Philip Klass) I'm not clear on the relationship between the new, as of August 1978, ICAO separation standards and categories of aircraft by weight. Why are those not being used by the U.S. as a member of the ICAO, or are they being used at what one might call ICAO-type airports? Can somebody clarify that for me?

MR. WEDAN: I'd like a volunteer for that one please. Who can handle that one? Joe.

Answer: (By Joe Tymczyszyn, Sr.) The definition of Heavy came about in 1970, just about the time that we were certificating

the 747. When you wonder about 300,000 pounds, where did that come from, that has no basis in the world of aerodynamics or physics. It was a convenient dividing line that would catch the large 707 and the large DC-8 in a same family of airplanes as the 747.

When the first 747 arrived at Orley, the airport was shut down for one hour, because of a threat of wake vortex turbulence. So, in order to say, now wait a minute, this is a lot of funny thinking in an engineering world, we said, weight is certainly a dominant factor in a world of airplanes with an aspect ratio of seven, so 300,000 pounds would form a convenient dividing line. There's no real merit to it, so, I think, if you want to consider it, it is time to rename those categories and something well over 300,000 pounds would be convenient.

For example, a 1011 or DC-10 at landing weight; at Los Angeles it can land on a south runway even with the tunnel restriction. In a sense, it's approaching the weight of a heavy 707 or DC-8. It is time to think about revising those weights. We didn't know any better, in the first place, and that was a good point to start with.

MR. WEDAN: I think we got a couple of volunteers for comments. Bill Codner, first.

MR. CODNER: Thank you. I wouldn't care to answer really, on behalf of the U.S. in this regard, but I think the answer to your question, if I understood your question correctly, Phil, "Is the United States applying the ICAO separation standards?" - the answer is "Yes."

The UK is applying modified standards which are slightly stretched, because at this time, we are not confident of the information that we have that the separation standards that were agreed to in ICAO are necessarily good.

Question: (By Robert Wedan) I've understood that ICAO has replies to lower boundaries, or the boundaries for the low small airplanes upwards from 12,500 to 17,000 kilos. Is that a UK boundary?

Answer: (By Bill Codner) No, that is, the UK is revising this, because, at the moment, we are not really satisfied that the ICAO standards are satisfactory for our use.

Now, I think the answer for the U.S. is that you are using the ICAO standards at the present time, and we're using separation standards which are slightly more stringent.

MR. WEDAN: Wim, did you want to add to that?

MR. AARDOOM: Yes, just a short one. Being at the ATC, where the guidance material was produced; first, the two limits were open to debate. First, 170 ton limit allowing only 1011, DC-10, and 747 to be called Heavy. The other option was 136 tons which is obviously now the guidance material.

Both were in the draft material; for one reason or the other some ATC Education Commission members had some damage, about something else, and to erase out 170 tons without consultation with states, as I understand it from the proceedings.

The ATC left both options open to be decided by the states.

Thank you.

MR. WEDAN: Go ahead, Frank.

MR. ERADY: Since, we are not rushed for time, I think it might be interesting to the group here. Many of you may not of heard of this incident, but it involves a very light category of aircraft involved in a wake vortex accident.

The pedal power aircraft out on the desert, before the Kramer prize was won, I'm not sure whether it was actually in flight or sitting on the ground. I see somebody nodding and maybe somebody knows this story better than I. But, anyway an agricultural aircraft took off, and the story I heard was that five minutes later, the wake vortex broke this airplane, and so maybe if we have to divide into categories, maybe we ought to go down pretty low in this situation.

MR. WEDAN: Well, maybe we have to have a category for the Gossamer Condor.

Jack Enders has his hand up.

MR. ENDERS : I'd like to respond a little bit to some concerns expressed by Captain Davies and Joe Tymczyszyn, Sr., regarding airborne vortex detection.

Earlier in the NASA Program, we attempted to see if, as an alternative, one could visually mark vortices in an environmentally acceptable way. This was pretty much of a long shot that we tried at JPL.

It paid off to a limited extent in that what evolved out of that effort was a Chemical Marking System that is useful for research purposes, but the hardware involved is a bit cumbersome for operational use. Specifications we had laid on were that the trailing vortex had to be marked for a short period of time and then disappear so that in a normal, heavy air traffic situation you wouldn't fill the terminal area with visible smoke or harmful chemicals. This was one effort to provide some self-vortex-clearance capability to that traffic which would be concerned about vortices.

Regarding more sophisticated sensors, I think that some of the recent success we have had in clear air turbulence sensing and wind shear sensing, might in the next two or three years bear some fruit in the area of sensing vortices.

We have three systems that we are going into the air with in January, February and March aboard the NASA Convair 990. There's an infra-red radiometer system that Pete Kuhn, from the NOAA Wave Propagation Laboratory, is working on; there is a Passive Micro-wave Sensor that came off the Nimbus G Satellite that is being engineered by JPL; and then, of course, our old standby, the Laser Doppler Velocimeter from Marshall Space Flight Center.

All three of these systems will be aboard the Convair 990 in early 1979 to sense common patches of turbulence and to see how

each of these three different system concepts perform. The infrared radiometer that Pete Kuhn has been working on, has already been applied to the airborne wind shear detection problem and has met with some success.

We hope that while perhaps none of these individual concepts alone may provide all the answers we need, we may get out of this series of tests an indication of feasibility of some kind of a hybrid system, where combinations of features of these three concepts might provide the answers to all these problems, at least for the pilot of the large aircraft.

MR. WEDAN: Very good. Thank you, Jack. I see two more hands. Let's pick the one in the back, Joe, first.

MR. WHITE: Thank you, sir. My name is Lawson White, International Air Transport Association. This, of course, is an international problem which is being addressed here in the United States, and, with the exception of what I've heard from the United Kingdom and the Netherlands, *very little seems to be happening internationally.* I can envision some problems, perhaps in some states, accepting the criteria which will be adopted at Chicago when this VAS system goes into operation, and I would like somebody to respond as to what is being done internationally to make the criteria acceptable, internationally?

MR. WEDAN: Okay, the question was, "What is being done to effect, I believe that's a ground based system that you're referring to, specifically, the VAS system that would be employed at Chicago, O'Hare, the international adoption of that technique?" Any volunteers for that question? I don't see a resounding desire to respond to it, and I think this comes into one of the categories of work to be done. Pilot training is also in the area of work to be done. I think, I would agree, and I'm sure others would agree that this is an area that hasn't yet been fully developed. There's a lot of work to be done.

Does anybody wish to add to that? Joe.

DR. TYMCZYSZYN, JR: Well, since I had a question to ask myself, I might as well try to respond to this.

We haven't officially announced yet intentions to start up the VAS on April 1, although we've been saying it here in this meeting. The official announcement will come very shortly. I guess what we're going to have to do, we and FAA, will have to send the word up to the International Aviation Section of FAA who will then distribute it to the channels to get the word to the other nations. I'm not really familiar with those channels myself, but we have a group in FAA that's supposed to handle that type of thing.

If a foreign carrier doesn't believe in VAS, and we've extended the option to our own people, if a foreign carrier of any airline pilot requests pre-VAS separations, he will be given them, but, obviously, we'd like to get the word out in time.

MR. WEDAN: I would suggest Joe, that since this question is one that is closest to your work that you might want to discuss it further in the workshop, and since it appears to be in the area of a recommendation of work to be done in the future, maybe it's one of those things you'd like to include.

DR. TYMCZYSZYN, JR: Well, there's not much to discuss, it's just something we have to do, and I'm glad you brought it up, and when I get back to work, I'll get the word up to the International Aviation people in FAA and we'll start the process.

MR. WEDAN : Joe, did you have any other comments?

MR. TYMCZYSZYN, SR.: Yes, I had a question for Frank Brady of ATA, and maybe the airframe manufacturers might want to respond too.

You spoke highly of the alleviation and several times you said to FAA, and NASA and Congress that it's a good thing and work should continue. Do you know if any of your member airlines have ever inquired of an airframe manufacturer about the possibility of having one of their aircraft modified with an alleviation system or a new aircraft delivered with an alleviation system or getting

a cost estimate, or doing this, or, in other words, has any airline gone any further than endorse this to NASA, FAA and to Congress. Have they gone to the airframe manufacturers, and asked what it would cost them to buy that type of alleviation equipment on an aircraft?

Answer: (By Frank Brady) Well, the answer is, I have no knowledge of those contacts, it's not necessarily true that we would learn of it, but, I don't know of any such contacts.

MR. WEDAN: Any of the representatives from the airframe manufacturers like to comment on that?

MR. LUNDRY : I only know of one such contact and I believe it was Delta Airlines, came to us about two years ago, and we were discussing the 7X7 Program, which has now developed into the 767 Program.

The question that was asked at that time was, we were considering implementing a program at that time, if we delayed the start of this program by two or three years, what improvements in Wake Vortex technology will occur that we could then use on the aircraft?

We showed them what was available at that time, in terms of NASA results and Boeing's estimates of the cost, and they felt at that time that those were unacceptable, and that's the only question that I am aware of.

I should remind you that I'm in a research group rather than a product development group and only learn about these things second hand.

MR. WEDAN: I think that it's worth discussing in one of the workshops, yours Joe? The question of what the role of government is to stimulate the action, if any? Should there be a leadership role performed by the government, and if so, in what sense, and should it be a NASA, FAA type of responsibility, or should we let the market forces dictate future steps?

I'd like to suggest that, even though we're a little bit ahead of time, that this might be a good time to get underway with the workshops. Has anybody got any burning point they want to make at this time?

Yes, I see one.

MR. CROOM : Delwin Croom, NASA. In response to the questions just asked, has anyone approached this type of activity, installation, or testing or something on an alleviation system?

We have had some contacts, I think they would be very interested in doing something with the A-300. We will be discussing this with him at his meeting coming in the States, in March, he's scheduled to come over.

First proposal is, if you try to tell them what to do, they will furnish the airplane and make it work. I don't know what he means, but, that's the understanding I have. I predict that will be the first one with alleviation.

MR. WEDAN: The master plan for the day calls for returning here at 3:00 p.m., this afternoon, where we will hear the reports from the three workshop chairmen.

I believe Ken Hodge and I will be making the rounds during the day to see how the work is proceeding. If it appears as though there's a chance of getting together earlier than that, it might be valuable to interact a little bit, because we are dealing with three separate questions. So, we'll be trying to bend the schedule a little bit, and please, keep alert to that possibility if you drift off on your own.

Now, just to remind everyone who's interested where you are going, the first workshop deals with the Wake Vortex Alleviation at the source, and Joe Stickle is the chairmen of that, and Joe, will you please raise your hand. He's right back there on my left, and that will be up on the 12th floor, in the Management Information Center.

The second workshop deals with the development of Wake Vortex Avoidance Systems. The advancement beyond the Advisory Systems on the ground based equipment; Guice Tinsley is the chairman of that, and he's raising his hand up in front here. That's in room 947 that's on floor number 9.

Workshop number three deals with the question of operational and safety procedures and regulations, and that will be chaired by Joe Tymczyszyn, Jr., and everybody knows where you're sitting by now, I think. He'll be meeting on the 11th floor in room 1120.

Again, with the possibility that we try to get together a little earlier. I hope to see you all then, and Ken Hodge and I will be looking forward to your comments. Ken, do you have a comment now?

MR. HODGE : Is there further elaboration on the laboratory tour agenda?

MR. WEDAN: There was a note I saw on the blackboard indicating a tour of the laboratories that is scheduled for 11:30 a.m., please sign up.

If anybody wants to make any further comments on that, as to what the tour would involve, what laboratories would be displayed, or whatever? Yes, Bill.

MR. WOOD : The only requests we've had are for the voice response system and the tire testing laboratory. Both of those will be available. If you meet out here at 11:30 a.m., there will be somebody to take you to both of them. They last about 15 to 20 minutes, I'd say. One of the labs is upstairs, the other is down in the other building, and it will probably be over by 12:00 p.m., easily. You can sign up out there, if you would. There are about five people presently signed up, which we can easily take through one straight tour. If there are others we would like to know about it now.

We will be leaving at 11:30 a.m., right out here at the blackboard.

MR. WEDAN: Breaks for coffee and for lunch are at the discretion of the session chairman. So, if you get hungry, blame them. We'll see you a little later on this afternoon.

SESSION VIII
WORKSHOPS
(Reports of these workshops
appear in Session IX)

SESSION IX
REPORTS BY WORKSHOP CHAIRMAN

MR. HODGE : Gentlemen, we're now at Session 9, which is to contain Reports by the Workshop Chairmen. The way we thought we would do this is to allow up to 15 minutes for each of the three chairmen to give their reports. This will give us a few minutes for some questions.

I'd like to remind you all, that for those here or those who have attended and left early, the record will be kept open for 60 days for further input that one would like to see put into the Conference Proceedings.

The bus will be here at 4:00 p.m. and it will go as soon as we're already to go. Since I don't see Joe Stickle, I think we could start with you, Guice. Are you ready? All right, so we'll have next Workshop Two, Development of WVAS on the ground. Here's Guice Tinsley.

MR. TINSLEY: As soon as I find my notes, we talked about Wake Vortex Alleviation also, so you won't be able to tell the difference.

MR. HODGE : I might mention, too, that the Workshop Chairmen should strive to get a fairly clear typed copy of their notes to both Bob and me, as soon as they can. It's not necessary today.

MR. TINSLEY : Okay, what I'm going to give is a majority report from the Committee and as I offered, anybody on the Committee that wants to talk, will have time, I'm sure.

The first thing I want to do is just quickly go through a little bit about the Low Level Wind Shear Alert System that we are installing, which uses anemometers. We clarified the difference between this system and the Vortex Advisory System that's in Chicago.

There are a couple of misunderstandings that I've heard throughout our sessions here and some of the questions indicate a misunderstanding that maybe I can clarify quickly.

The VAS System in Chicago will, handle very shortly the wind shear task, and what I mean, is that it will be able to detect this 15 knot vector difference.

The VAS System can handle a wind shear problem. It's a program change. We're going to put a different display down in the equipment room as a demonstration device. We are not going to interfere with the VAS operation until we're finished with this operational demonstration, but there will be a display down in the equipment room. It will demonstrate that the VAS will do the wind shear problem.

The reverse is not necessarily true. I say not necessarily because the way the system is designed now, it will not do the VAS problem. That's not to say that there might not be some design changes or some improvements that could be made so that the Low Level Wind Shear Alert System could do the VAS problem, but the way it is presently designed, it will not do it.

There are several reasons for this, and the primary one is our data rates that we deal in. The VAS System uses ground lines. The data rate from the remote towers is two per second. In our Low Level Wind Shear Alert System, we poll the towers once every seven seconds sequentially. It's a vastly different data rate.

I hope I've made myself clear. The Vortex Advisory System that's at Chicago will very shortly handle the wind shear problem.

Future VAS systems will be able to handle the wind shear problem. A single system will do both.

The Low Level Wind Shear Alert System as it is now being installed does not handle the Vortex Advisory problem. They are not compatible at this time.

That was a question of the gentleman from Miami. He's going to have one of the Low Level Wind Shear Alert Systems going in. He said, "Why don't we put the VAS in with it?" Well, this just cannot be done at this time.

Now there's a difference in cost in this too. The Low Level Wind Shear Alert Systems are being installed. The equipment costs about \$35,000. The installations costs are running about \$35,000. So for about \$70,000 were putting the systems in.

The Vortex Advisory System in Chicago costs us about \$600,000, over \$400,000 being for installation. This is probably the most expensive one that will be installed because Chicago essentially has two airports. So we think that possibly a half to a third of the cost for the next one. But, because of the extensive ground cabling that had to go into Chicago, the expense was quite high. We had to have cement encased conduit. The City of Chicago is very restrictive on the way they allow cabling to go into Chicago, and this is expensive. Looking at the future VAS installations, depending on the accessibility of ground lines, there could be a vast difference in the installation costs for VAS Systems.

Okay, we got into a Vortex Alleviation discussion.

A quick summary of it, I think we have an appreciation, and I think everybody's pretty much in agreement that what we talked about in the ground world is sort of an interim step, and that the ultimate answer and the desire of everybody is to have a Vortex Alleviation system that's designed into the airplane.

Certainly we support the work that's going on at NASA, and I hope that there is some way we can encourage whoever has to be encouraged to continue this work, and that we are interested and we do recognize that the final answer has to be in alleviation.

Things we got into, there are some specific objectives that we're working towards, and let me read them to you so you realize what we're going against.

First objective was, "What is the requirement for the development of WVAS?" Now, again, the difference between the Vortex Advisory System and the Wake Vortex Avoidance System is not clear cut. We're not sure, exactly, what a Wake Vortex Avoidance System would be.

It was asked by one of the gentlemen in our group, "Are you considering an airborne detection device as a possible WVAS?" I think this is an excellent point, and as we work towards this design of what a WVAS might be, we must continue to consider what we can do with airborne sensing.

The point was made, and I think it was a good point, that as we go into the MLS environment, an airborne detection device would possibly allow you to fly a different type precision approach and actually avoid vortices ahead of you. I don't think we traditionally do this on ILS Final now, but with an MLS type approach, you could fly a precision approach, and you could avoid a detected vortex ahead of you.

We do feel as we look to what the future holds, that we must gain VAS experience at Chicago. That is, we must operate, we must find out what we can do to gain maximum advantage from this type of system. Now, if that means additional sensors for enhancement, that should be pursued.

We should look at ways that we can extend the area of coverage. The work we've done up to this point has been out to the outer marker, and we must see what we can do to extend this out to where they turn the aircraft on final at a place like Chicago. Now possibly this is an area where we're going to have to get additional data, or we must look at possible merging techniques where we are able to avoid the areas where the vortices might be. Well, we've got to look at two things. We need more data so that we can resolve the issue or can we come up with a merging technique different from what they now do at Chicago.

Another thing that we feel we must do as we look to the future, e.g., come up with a better understanding of and a determination of hazard criteria.

One of the ways that we looked at this was proposed by one of the gentlemen involved in flying the airplane. It is straight forward, breaking the approach into three areas. Middle marker to touchdown, where he felt the encounter might put him into the ground. This is certainly unsatisfactory.

There's another area that runs from the middle marker out to the outer marker region, where an encounter might force him to make a missed approach. This is operationally unacceptable.

The third area is any position outside the outer marker where an encounter might be termed an emotional type impact. In fact, an encounter might upset you a bit, but it would not prevent you from continuing the approach. This is one way of looking at it, but we need to have an acceptable definition so that we're able to scope what we can do in these areas out beyond the outer marker.

The second objective we work towards, since we didn't answer the first one was "What should the priorities for development be?" What I've been saying already, we should proceed with the VAS, doing what we can to enhance it, doing what we can to expand the area of coverage.

We felt that we should work to include both transport and decay criteria in the present system.

If we are able then to accomplish near 100 per cent effective use at three miles with VAS, then we should proceed to the next logical step of two and one half miles. As we approach this (going below three miles), then somebody and I think it's got to be somebody within our group, look at the total system problem. That is, "What happens to our runway occupancy time?" "What happens to getting airplanes from runways back to parking areas?" and, "Where do we park this highly efficient fleet that we're bringing in every two and one half miles in a very heavily used airport?" We rapidly approach other bottlenecks once we become efficient and are able to overcome the vortex problem.

The third question we asked is, "After **identifying** the Vortex Elimination/Avoidance Interface with the overall airport capacity problem, is metering and spacing required for a WVAS System?" Now we use the metering and spacing hang-up as an argument that if we need metering and spacing, it is not really available, and may not be available for a couple of years, so, this is an argument for maybe not proceeding as fast as other people would like

toward a Vortex Avoidance System.

The way our discussion went in our group was simply this. If you are going to go to a reduced adaptive type spacing, that is, tailored to aircraft pairs, there must be some kind of metering and spacing.

As soon as we drop below a conventional or a three mile spacing across the board, then the requirement as we go lower, becomes greater and greater for metering and spacing.

I think we also voiced the opinion that we probably would not wait to add VAS enhancement for metering and spacing but should continue at a rapid pace.

Let me conclude and just summarize very quickly the important points. We think we ought to pursue the VAS, extend the coverage in both time and area, and look to the additional sites.

We certainly need a better definition of what a WVAS might be, and work towards developing whatever long-lead items might exist in this system, and I say specifically in this area, "What can we do with sensors that can actually track vortices?"

Third, where we recognize the VAS, VAS as a short-term interim approach, we must proceed with the Vortex Alleviation airborne solution.

MR. WEDAN: Questions, before you go?

AUDIENCE MEMBER: I've got one to start with?

MR. TINSLEY : Yes sir.

Question (By Audience Member) I got the impression, Guice, that we're talking about continuing Chicago as a test bed area, an operational test bed area, for an indefinite period, as we move on toward various enhancement ideas on the basic VAS. Is that the opinion of the group that this would be the case, and if so, how do we arrive at some sort of a design description, or a freeze or a configuration in control, if you will, that could be used for implementation at other airports?

Answer (By Guice Tinsley) Well, I can see where you come to that conclusion, the way we keep talking about things that are going to improve, but, take them separately, you know, why would we use Chicago to demonstrate the wind shear capability. Well, that's the only one we've got to work on. We're not going to impact how it operates as an advisory system, but using the computer and the input from the winds that come in from these towers. Any change that we would make, the addition of another sensor, yes, it would change it, this would be in a test site demonstration condition again. Any future site that goes in is going to be tailored to that airport. It's not going to look like Chicago. So, each site will be tailored and I hope we could include the newer additional sensors that give us greater capabilities so that they may not be a standard until we get, maybe, two or three airports down the road.

MR. HODGE : Okay now, Joe Stickle, are you ready for the report of the Wake Vortex Alleviation Workshop?

MR. STICKLE : Guice said he ended up talking about alleviation in his workshop. We talked only about avoidance.

We did come up with some summary statements, and I'd like to begin by stating what the objective was.

First, we were trying to assess in the group what we thought the state of the art is. With respect to current designs and to new designs, I'll say that there was not a unanimous agreement on the technology assessment for either case.

The second objective we wanted was to recommend specific areas of research or demonstration that would be required in order to initiate an implementation program. We never reached the second objective because we never could decide whether to have an implementation program. We reached the latter conclusion because we couldn't agree that the state of the art was ready. I will make some statements, summarizing what we thought the state of the art was and what the group felt needed to be done, before we could implement Vortex Alleviation. However, we didn't come up with any recommended best approach.

Let me have that first slide for the Vortex Minimization. The first summary statement is that there does appear to be a renewed interest in the source alleviation. The early attitudes that had been reflected prior to the conference was that VAS, the Vortex Avoidance System, would solve the problem and alleviation could be eliminated.

From the comments that were made during the conference the Vortex Advisory System is a starting point to get us back to the three mile separation. However, for improving or increasing airport capacity in the future, it's not a solution to the problem.

There was agreement within the group that alleviation at the source is feasible as has been demonstrated both in model and full scale. However there was also the feeling that the mechanism of the alleviation is not really understood. There are various ways of altering the vortex roll up and enhancing it's decay.

We've got some good ideas, but we haven't gone into an indepth design study that shows we can practically apply it to either the current fleet or new aircraft. That doesn't mean we can't work the problem. We do this through the experience we build up in testing empirical solutions, and in the use and the exercise of the analytical tools that we have. But, we are the first to admit that we don't understand all the phenomena of alleviation yet.

The next point is that alleviation is a long term solution. If we had decided today to proceed with alleviation, it would be a number of years before the system would realize the impact of any reduction in delays that would be a result of the alleviation.

The point on the other side is that the capacity problem, which alleviation is supposed to help resolve, is not critical at this time. Projections indicate that 20 airports will exceed their capacity by, I think, 1985. So we're really looking at a long term problem.

I really think this is the time we ought to be looking at a long term solution.

Neither NASA or the FAA know at this time what the cost of implementation will be because that's going to depend on the particular solution or mechanism that's put on any given aircraft, and it may vary from one aircraft to another.

One point that was brought out with respect to alleviation, is that anything done to change the landing configuration of the aircraft would be implemented at all airports and be used all the time.

From the standpoint of safety, this would probably be good. But, if it's going to cost you \$2.00 to \$5.00 an approach as indicated earlier, you will be applying the solution to all the airports, and your problem may be only at 6 to 20 airports. The cost really should be considered from a total airport or system situation.

There were some inputs from discussions with industry about **vortex alleviation**. These comments had come earlier in the vortex program and were from talks that the FAA had with the manufacturers.

The first comment is that the management indicates doubts that the technology is ready. They're not ready to commit to it. They're not convinced that alleviation is here to the point that they can design it into the airplane on a cost effective basis.

Solutions that we have proposed today increase the noise, or increase the fuel consumption and are in conflict with other national priority problems. For that reason, they would like not to have to consider **vortex alleviation**.

There is a resistance also to a passing of a regulation today which they feel to be a future problem. The problem there being capacity.

The last point is that the cost/benefit is unknown. We talked a lot the other day about separations and delays and what it does to you, but the **vortex** contribution to separation or the **vortex** contribution to delay hasn't been identified, and it's a key point.

I think some of the future studies that are undertaken by FAA or others, ought to consider trying to indicate what part of the delay is attributable to the increase in separations necessitated by wake vortices.

May we have the next slide. I think this was pretty evident throughout the workshop. Nobody's really satisfied with the situation we have.

As Vern Rossow pointed out, we have sort of a chicken and the egg situation and we have a lot more chicken than we do eggs. On the other hand, the incentive, either a financial incentive, a legislative incentive, nor a liability incentive, exists which would force anybody to make a decision.

That sort of summarizes the general discussion that we had, and I'd like to get into some of the recommendations that the committee or the group workshop did come up with.

Number One. That research and development should continue to look for new and improved concepts. The Vortex Minimization Program as we heard yesterday, will be phasing out at the end of 1980. Vortex minimization research should be continued and I think it's pretty well assured that NASA will continue at a small R&D level with a limited amount of resources.

Continued research should be a recommendation from this committee. The recommendations that follow tend to expand on what would be done in a research program.

The government, and I put that as government because we didn't decide whether it was NASA, FAA, or who, should sponsor studies to identify the cost and complexity of some of these modifications that we are talking about. Those modifications may be applied to the retrofit case with the current fleet, or to the new designs that are coming down the road.

The recommendation was that a high priority should be put on looking at the new design case, because if you can influence a design for minimum cost, it's going to be done during the pre-design phase, not after the aircraft is built.

There was one other area that we did talk about and we tried to come up with a recommendation. It was relative to how do you get off of the center of the fence. The suggestions that have been proposed include the FAA issuing an advance notice of proposed rule making and getting the industry to respond. That met with mixed emotions right then in the room. Another was to work with the airport operators, particularly at the congested airports and start charging landing fees based on the amount of air space that you utilize during an approach.

There are several financial and regulatory approaches that could be taken, but we as a group I don't think are qualified to make specific recommendations to those issues. I think it is an issue that ought to be taken to the industry and to the airlines sitting together in a room. If they decide that the problem (capacity) is not big enough to worry about, then we ought to leave the room and simply continue a low-level R&D effort.

Is there anyone from the committee that would like to add or subtract from the things that I've said? If not, then you can open it up for questions.

MR. GESSOW : I think that in some respects the recommendations might be a little inconsistent with the points that were made earlier. One of the things that didn't come through clearly is that most of us felt that although our understanding of the phenomena is incomplete, if implementation was decided upon, then there is enough knowledge in hand to carry out an implementation program for a specific aircraft if the costs and the other benefits warranted a decision to start such a program.

MR. STICKLE : Okay, that understanding was yours, mine, and several others in the room, although I didn't think we had a unanimous agreement in there, that that was the case.

MR. GESSOW : There might not have been unanimous agreement, but most of the group felt that way.

MR STICKLE : Well, I feel like that, and you felt like it, and I think several others felt like it, but there were some there who did not.

MR. GESSOW : Well, then, if your first point represented a consensus of the group, then why should we go on with recommendations two and three?

MR. STICKLE : Well, for one thing, we've demonstrated alleviation on the existing fleet. We've done it from an experimental basis, but not from an operational sense. So, we need to identify what cost would be associated if you would apply that concept to the current fleet.

I think several of us felt we have the tools today that can be used to assess and evaluate some of the changes on the new designs. Working with the industry, I think they can take those and then turn around and give us an idea of what that cost would be, and then have a comparison of what a retrofit versus a new cost would involve.

MR. GESSOW : One further comment: I would like to see Item 2 stated a bit more broadly, namely that the government should sponsor studies which would investigate the implications of implementing some of these alleviation procedures, including economic, operational, and safety factors.

MR. STICKLE : I guess, that was my comment on complexity, because the complexity that's involved not only involves the mechanical complexity, but the influences of other operational problems, and safety problems that you might have. Are there other comments?

There is one question Jerry Chaykin raised at the last moment. He wanted us to vote on whether or not we ought to press for flight tests on the DC-10, if they were to become available in February of next year. The consensus was that a vote would be premature because we feel we don't have enough model data at this time to support it. We do have additional model test that will come in the March time frame with the DC-10 in the V/STOL Tunnel which would

be looking for improved alleviation schemes for the DC-10. Depending on what we have then, and after we have some of our landing and ground effect tests cleared away, then we may consider the DC-10 tests would be needed. Right now, we feel that it is too premature to push for that as a major program.

MR. HODGE : All right. If there are no further questions, we'll hear from the third workshop Chairman, Joe Tymczyszyn, Jr. on Operational and Safety Procedures.

DR. TYMCZYSZYN, JR: I don't have any view graphs. The first part of the workshop dealt only with VAS, so I'll talk just about VAS now.

The FAA needs to announce the start of VAS very soon. The starting date will probably be April 1. We have to get started real fast on pilot education. We asked each group what they thought they would need before starting. The airline group said that they would need the FAA film; they would need a final writeup with more details of VAS. In other words, more thorough than the film, and they would need a boiled down version of Hallock's Safety Analysis, as Jim's is one inch thick, but they need a much shorter one that hits the high points but is easier to understand.

VAS should be a part of airline recurrent training, although since that only happens every six months some of the captains won't have recurrent training before VAS starts, but everybody should be handled other than recurrent training through bulletins and initial sheets and so forth.

Hallock feels that it would be very good for each pilot to have personal instruction in recurrent training on VAS. For business aircraft, we've got to get something out in AIM Part 3A pretty quick. NBAA asked for about the same thing as the airlines would get in terms of the film and our final write-up of VAS and the safety analysis.

These comments we ought to coordinate, also internationally and with the Air Force. Myron Clark gave the phone number of the FAA VAS Program Office and made them available to any group that wants to have a meeting to discuss VAS further.

We discussed and probably recommend that Flight Standards put out Air Carrier Operations Bulletins in which we'd call for the Principal Operation Inspectors of the airlines and the FAA people to talk it over with the carriers to get VAS into a training program.

Now, when we operate VAS, we will have reports of any encounters. We're not expecting any encounters, but if we get one, the pilot will call the controller on the microphone right away and VAS will be stopped immediately if the incident had something to do with VAS. In other words, if VAS was in a red light condition, and they weren't even using it and there was an incident, we're not going to stop VAS because of it. But, if VAS was being operated, VAS spacings were being used and we have an incident, then we would call a halt to it and investigate it on the spot.

The criteria for what's an unacceptable incident will mostly be left up to pilot judgment. If he defines it as hazardous, he will be interviewed.

There will be an FAA point of contact there at Chicago with a phone number available. He'll be physically located at Chicago. We need to have a form for uniform reporting of these incidents, and both the UK and Canada volunteered to give us their forms to work from.

We also want to keep a count of the number of missed approaches due to the light going from green to red and also double missed approaches.

We will have a problem in that sometimes a pilot will encounter engine turbulence or engine wake from a departing aircraft. We're going to have to look at that so we don't consider that a **vortex** encounter.

The VAS status of each runway will not be on the ATIS because there are too many runways, some on red, some on green-too complex-so each pilot should then assume that VAS is on the green light. Runway selection will not be based on VAS for two reasons.

Number One, the air traffic controllers tell us the changing of runway, in other words, trying to get a green light runway instead of a red light runway, loses you more capacity than you get by having a green light. Secondly, we're not going to give the pilot a runway with a crosswind on purpose, especially if it's icy or wet, just so he'd get a green light.

We did determine that there was an increased need for coordination on VAS and the Low Level Wind Shear Alert System as I have already suggested.

Okay, that ends VAS. Then we started talking about alleviation and before we got into a technical discussion of the operational and certification end of it, we came up with some big picture items.

Everyone was in agreement that it was obvious that alleviation is needed. It's more a question of timing. One problem, of course, is the benefit does not accrue to the guy who pays his money directly; then there is a chicken and the egg problem.

Nobody wants to see the alleviation work die out. We do need studies of operational and certification aspects with FAA and NASA.

Now, in the past, the airlines have wanted to solve the delay problem on the ground with FAA money, and this appealed to a large number of FAA people, who were ground based oriented. But, the feeling is swinging around such that we now see that alleviation is extremely desirable and almost inevitable if the system is going to keep growing; at least, we hope it will. The interest of the airlines manufacturers seems to be on the upswing.

The government, FAA, NASA, and TSC, should provide the leadership and the catalyst; though, we definitely can't go it alone without the airlines and the manufacturers.

The economic analysis of these alternatives to achieve more acceptance should be continued because we found a lack of people accepting the economic analysis and its results.

Now, we then turn to specific recommendations on programs which FAA, NASA, and TSC should find and undertake and support with people and money to study the operational and certification aspects of alleviation.

The first idea, which was similar to Workshop One, was to give seed money contracts to the three aircraft manufacturers for looking at how to certify the alleviated aircraft---new and retrofit.

Now the idea here is to find out if they are certifiable and how much extra cost, complexity, drawbacks, noise, fuel, and bad aspects would come up, but if we know how to certify something that means we know it pretty damn well. So, trying to figure out how to certify it would get us a lot of answers.

The items in there, I'll just go over very quickly; you don't need to copy all these down, they're technical items like approach speed, landing distances, spoilers retraction if near the stall, increase pitch attitude, trim requirements, failure mode, maintaining roll control without stopping the alleviation, noise, engine treatment, fuel, structures, operational items, and normal and emergency missed approaches. The FAA certification engineers and pilots should be involved in this and preferably the FAA input on this would be working with the companies in the region, so the Boeing people would be working with the FAA Northwest Region certification people.

It was pointed out that the company can't make all the decisions on what the FAA is going to accept. They're going to be dickering back and forth with the FAA, so the FAA certification people have to get in on it.

That was number one, not in priority, but just in the order I'm giving.

The next project which would require FAA, NASA, and TSC work, is a short term project to redefine the boundaries between the categories **Heavy**, **Large** and **Small**. Everybody knows there's no particular rational basis for having 12,500 pounds and 300,000 pounds be the boundaries.

We should redefine it based on the hazard and not the maximum gross take-off weight. There's some suggestions of using the actual landing weight or actual take-off weight, we didn't get far into it. But, we have situations now where a so called heavy 707 could land at a lighter weight than the so called non-Heavy 707 and that doesn't make much sense.

Also, the 767-200 may eventually grow to over 300,000 pounds but because of its higher aspect ratio; it will probably have a much weaker vortex than a lot of the so called Large aircraft, and might have shown an improvement of about 3 per cent, for example, if the Heavy 707's and DC8's could be reclassified as Large.

Well, that's part of Phase One of a certain effort. Phase Two is longer term and goes in a little deeper. How would we be able to certify an alleviated aircraft, say an alleviated Heavy as a Large or a Small, and, therefore, give reduced spacing behind it. This would take work by FAA, NASA and TSC. They would require a combination of flight tests, wind tunnel, water tank, smoke towers, laser van, analysis, big computers, and we'd have to search out the whole envelope to make sure there were no vortices anywhere.

Now, I leave the recommended research project for just a minute to insert a few recommendations. I didn't find any enthusiasm in my group for rule-making, either advanced notice or notice of proposed rule-making, and people felt we could, if you wanted information from the industry, technical discussions, get it faster through meetings like this or technical meetings, rather than the advanced notice of proposed rule-making process.

There's also a discussion about the philosophy of rule-making for increasing capacity as opposed to our normal function of rule-making for safety.

We had a pretty lively discussion, but we didn't come to any agreement on use of landing fees, that is, charge higher landing fees for the aircraft that requires others to follow it at six miles, and so forth.

Another effort that requires further R&D which is already begun, but hasn't been completed by TSC and FAA and which may need NASA help, is how do we get reduced separations outside the outer marker and preferably with VAS?

At Chicago we're hamstrung in that the aircraft have five-mile separation outside the outer marker if it's a large following a Heavy. Then you can use three miles inside the outer marker, but you can't get there because you can't close up two miles in two and one half minutes. So, if we could get shorter separations outside the outer marker, that would improve the payoff of VAS a lot, but we haven't been able to establish yet that it's safe, so it should be investigated.

If we can't show that it's safe with VAS, then probably only alleviation would work outside the outer marker which would then allow you to get actual three mile spacings. However, there may be problems in that event, because if the aircraft were in an approach configuration outside the outer marker as opposed to in a landing configuration, the alleviation probably won't work as well. In that case it might have to be put into landing configurations sooner and that would exact fuel penalties. So, we didn't come to any big conclusions on that, but we did identify it as a problem.

On the DC-10 flight tests, February and March 1979, we felt that the general concensus was we should try to fund it, because if we miss it, we don't know when we are going to get another DC-10 again for flight tests.

Now, on WVAS versus alleviation, and we included airborne also, we just decided there wasn't enough information today to make a decision on which way to go, but we feel that FAA should split its money so that hopefully a year from now, these projects that we have talked about, would provide enough data to put us in a better position to try to make a decision between alleviation or avoidance or a combination of them. That is, we need to know a little more before we can make major decisions on how we're going to spend millions and millions of dollars over the next ten

years. In other words, do enough studies to assess them, not necessarily to develop avoidance.

There was a lot of interest in airborne detection, a great deal more interest in the workshop than there was in the session, and people felt that money should be spent on it. Such that it could be brought to the same status as the other two so it can be evaluated also.

Another unknown was what do we do about take-off or departure? Nobody's come up with anything yet, but we'll need it.

The final general recommendation is that we and the FAA should probably support a letter from the FAA Administrator to the NASA Administrator re-emphasizing the importance of the program. Then we should back up our words with money and people and get together with NASA and TSC and develop an overall program plan for using the money and people on the problem. That's all.

MR.HODGE : Do we have any questions of Joe or any of the prior speakers?

Question (By Robert Wedan) Did I hear an inconsistency between your recommendations on the DC-10 from the previous recommendation?

Answer (By Joesph Tymczyszyn, Jr.) Yes.

MR. STICKLE : Yes, he did but you've got to remember one thing, that we made it on the basis that we might have a model test first. The model test is based on the availability of the model; we could put together a model and run the test earlier, then we'd be in agreement. So, if we had the model to test earlier, we could support that.

DR. TYMCZYSZYN, JR. : We didn't get a chance to discuss it in detail although it was obvious that if we miss that time slot of a two-week period at the end of February and early March of '79, there isn't going to be a DC-10 available for who knows when.

MR. HODGE : Now, it's the intent of Bob and myself as co-chairman to get together, hopefully, next week or the week

after, at the latest, with the three chairmen of the sessions to polish up the wording and what-not of these recommendations from the workshops and have them included in the proceedings.

I don't have any great words of wisdom to improve or enlarge upon these recommendations, I'll ask Bob if he does in a moment, however. This has been very useful to us in giving us some indications of the industry and other users' views on the subject of wake vortex alleviation and avoidance.

Question (By Kenneth Hodge) Bob, do you have further words to say?

Answer (Robert Wedan) I'd just like to make one comment, and I'd like to make it very clear, that the FAA is continuing work on the program contrary to what you may have concluded with respect to NASA's program.

We are continuing the work on the VAS at Chicago, we are planning to continue R&D work on enhancement possibilities, so some of these recommendations that have been made are in alignment with that. Our concerns about moving onto development work on more sophisticated systems was addressed. We feel comfortable that the comments coming back do fit very well with our concerns in that direction. We certainly are moving ahead with the program and the only question that we really have to finalize now is the extent to which we modify the progress we're making or intend to make.

Incidentally, I would like to take this opportunity to thank everybody who participated in the workshops. I'm very pleased with the feedback that we got, and we hope that we can polish it up to make something sensible out of the whole thing, and again, I appreciate the participation by everybody.

MR. HODGE : As a final word, I'd like to say that a good many of us here are familiar with the others working in this area from prior occasions, workshops, and what not, and I hope that we've made some additional contacts which will open and improve

channels of communication, so we can continue to work closely between industry and the government side of the activity as we continue our progress on the wake vortex avoidance and minimization.

Thank you, again.

U.S. GOVERNMENT PRINTING OFFICE: 1979 - 602-321/277