

MICROCOPY RESOLUTION TEST CHART
NATIONAL BUREAU OF STANDARDS-1963-A

AD A 078118

LEVEL *III*
80 42 322

ESL-TR-79-21

2

**SURVIVABILITY OF REMOTE SITE
ALTERNATE ENERGY SYSTEMS
VOLUME I - SURVIVABILITY ANALYSIS**

KARL E. SCHEUCH; GLENN T. BAIRD
ERIC H. WANG CIVIL ENGINEERING RESEARCH FACILITY
UNIVERSITY OF NEW MEXICO
BOX 25, UNIVERSITY STATION
ALBUQUERQUE, NM 87131

SEPTEMBER 1979

FINAL REPORT

SEPTEMBER 1978 - MARCH 1979

DDIC
RECEIVED
DEC 13 1979
ALBUQUERQUE

DDIC FILE COPY

APPROVED FOR PUBLIC RELEASE;
DISTRIBUTION UNLIMITED



AFESC

ENGINEERING AND SERVICES LABORATORY
AIR FORCE ENGINEERING AND SERVICES CENTER
TYNDALL AIR FORCE BASE, FLORIDA 32403

79 12 4 113

19 REPORT DOCUMENTATION PAGE		READ INSTRUCTIONS BEFORE COMPLETING FORM
1. REPORT NUMBER ESL-TR-79-21, Volume I-1	2. GOVT ACCESSION NO.	3. RECIPIENT'S CATALOG NUMBER 9
4. TITLE (and Subtitle) SURVIVABILITY OF REMOTE SITE ALTERNATE ENERGY SYSTEMS. VOLUME I. SURVIVABILITY ANALYSIS	5. TYPE OF REPORT & PERIOD COVERED Final Report Sep 1978-Mar 1979	
	6. PERFORMING ORG. REPORT NUMBER	
7. AUTHOR(s) Karl E. Scheuch and Glenn T. Baird	8. CONTRACT OR GRANT NUMBER(s) F29601-76-00015	
9. PERFORMING ORGANIZATION NAME AND ADDRESS Eric H. Wang Civil Engineering Research Facility University of New Mexico, Box 25, University Station, Albuquerque, NM 87131	10. PROGRAM ELEMENT, PROJECT, TASK AREA & WORK UNIT NUMBERS Program Element: 63723F JON: 2103-80-06	
11. CONTROLLING OFFICE NAME AND ADDRESS Engineering and Services Laboratory HQ AFESC/RDVA Tyndall Air Force Base, FL 32403	12. REPORT DATE September 1979	
14. MONITORING AGENCY NAME & ADDRESS (if different from Controlling Office) AFESC/ESL	13. NUMBER OF PAGES 81	15. SECURITY CLASS. (of this report) UNCLASSIFIED
		15a. DECLASSIFICATION/DOWNGRADING SCHEDULE
16. DISTRIBUTION STATEMENT (of this Report) Approved for public release; distribution unlimited.		
17. DISTRIBUTION STATEMENT (of the abstract entered in Block 20, if different from Report) B042-3226		
18. SUPPLEMENTARY NOTES Available in DDC		
19. KEY WORDS (Continue on reverse side if necessary and identify by block number) Remote USAF Sites Radioisotope Maintainability Alternate Energy Sources Energy Storage Devices Survivability Wind Batteries Geothermal Thermal Solar Reliability		
20. ABSTRACT (Continue on reverse side if necessary and identify by block number) As a result of increasing fuel costs and decreasing reserves, the USAF is studying the possibility of providing power to remote sites by means of alternate energy sources. Remote sites are identified and categorized. Several alternate energy sources are examined with respect to reliability, maintainability, and survivability against natural and man-made threats. Energy storage devices are also studied, and a final decision matrix is developed which relates these findings.		

SUMMARY

The objective of this report has been to examine the survivability, reliability, and maintainability of certain alternate energy systems for possible use in remote USAF site applications and to provide a decision matrix of this information to permit the USAF to plan future activities for the development and demonstration of alternate energy systems. To achieve this objective, it was necessary to identify remote USAF sites and to obtain climatological data for each site.

A discussion of the alternate energy systems is included in Section II along with a discussion of acquisition cost, operation and maintenance (O&M) costs, and system reliability. Section III deals with energy storage techniques. Section IV analyzes the survivability of the various energy systems. The decision matrix is presented in Section V.

Each alternate energy system was studied as a unit and not in combination with other alternate energy systems or diesel generators. It may prove that the most cost-effective, reliable, and survivable system is such a combination. Because the requirements for each site will vary with the climate, each site must be studied as an individual problem. Also, such hybrid systems as gallium arsenide photovoltaic cells were not investigated. Since alterations to the energy systems through improved technology or new components will develop, these systems may need to be revised in the future.

One other area not studied was the demand for space heating. The potential for space heat production was mentioned in Section II, but the additional costs were not discussed. Up to 50 percent of the total energy requirements of certain DEW sites in Alaska, Northern Canada, Greenland, and Iceland are needed for space heating alone. Here, improved insulation may help substantially; but the energy systems were mainly discussed with respect to production of electricity.

Certain remote USAF sites may well benefit from the use of an alternate energy concept. A sufficient number of sites offer potentials for solar, wind, or geothermal development; and many of the systems discussed offer reliability, maintainability, and survivability equal to the diesel generators presently used. There is still a need, though, for more detailed information on site layouts, requirements, and climatological data.

Conclusions from the analysis of survivability are: 1) solar systems are particularly susceptible to nuclear and conventional weapons effects, 2) geothermal and wind energy systems survive nuclear and conventional attacks sufficiently to retain some degree of operational capability, 3) hardening of systems is most effectively accomplished by undergrounding as many facilities as possible and dispersing the solar collector arrays. No system, with the possible exception of geothermal, can be completely hardened against the threats considered in this report.

This report shows that the USAF may find many applications for remote site alternate energy systems which offer a quicker pay-back period than can be found at non-remote sites because the cost of transporting fossil fuels to the remote sites is high. It is recommended that this work should be continued.

PREFACE

This report was prepared by the University of New Mexico's Eric H. Wang, Civil Engineering Research Facility (CERF), Kirtland Air Force Base, New Mexico under Contract F29601-76-C-0015, Subtask Statement 2.07, Job Order Number 21038006, for the Civil and Environmental Engineering Development Office (CEEDO), Tyndall Air Force Base, Florida. As of 15 March 1979, CEEDO became the Engineering and Services Laboratory of the Air Force Engineering and Services Center. Mr. Karl E. Scheuch and Mr. Glenn T. Baird performed the study. First Lieutenant Michael R. Mantz, HQ AFESC, was the Project Officer. Captain William A. Tolbert, HQ AFESC, was the Subtask Officer. This work was accomplished during the period from September 1978 to March 1979.

This report has been reviewed by the Information Office (OI) and is releasable to the National Technical Information Service (NTIS). At NTIS, it will be available to the general public, including foreign nations.

This technical report has been reviewed and is approved for publication.

William A. Tolbert
WILLIAM A. TOLBERT, Capt, USAF
Energy Research Engineer

Emil C. Frein
EMIL C. FREIN, Major, USAF
Chief, Environics Division

Joseph S. Pizzuto
JOSEPH S. PIZZUTO, Col, USAF, BSC
Director, Engineering and Services Laboratory

Accession For	
NTIS GRA&I	<input checked="" type="checkbox"/>
DDC TAB	<input type="checkbox"/>
Unannounced	<input type="checkbox"/>
Justification	<input type="checkbox"/>
By _____	
Distribution/	
Availability Codes	
Dist	Avail and/or special
A	

TABLE OF CONTENTS

Section	Title	Page
I	INTRODUCTION	1
II	ALTERNATE ENERGY SYSTEMS	3
	Introduction.	3
	Systems	4
	(1) Solar Gas-Turbine Generator	4
	(2) Solar Organic-Vapor Turbine Generator	7
	(3) Solar Photovoltaics	10
	(4) Solar Pond.	13
	(5) Solar Steam-Turbine Generator	17
	(6) Radioisotope-Fueled Gas Turbine Generator	19
	(7) Wind Energy Conversion System	21
	(8) Geothermal.	26
	(9) Other Systems	27
	Comparison.	28
III	ENERGY STORAGE SYSTEMS	33
	Introduction.	33
	Systems	34
	(1) Batteries	34
	(2) Lead-Acid	34
	(3) Advanced Batteries.	35
	(4) Thermal Storage	39
	(5) Flywheel.	40
	(6) Hydrogen.	41
	(7) Other Systems	42
	Summary	42
IV	SURVIVABILITY ANALYSIS	43
	Introduction.	43
	Approach.	43
	Survivability and System Hardening Methods.	50
	(1) Solar Gas-Turbine Generator	50
	(2) Solar Organic-Vapor Turbine Generator	51
	(3) Solar Photovoltaic Systems.	52

TABLE OF CONTENTS (CONCLUDED)

Section	Title	Page
	(4) Solar Pond	53
	(5) Solar Steam-Turbine Generator	54
	(6) Radioisotope-Fueled Gas Turbine Generator	56
	(7) Wind Energy Conversion Systems.	56
	(8) Geothermal.	57
V	DECISION MATRIX.	59
	Introduction.	59
	Matrix.	59
	BIBLIOGRAPHY	73

LIST OF FIGURES

Figure	Title	Page
1.	Concept of Individual Solar Gas-Turbine Power Module	5
2.	Schematic View of Solar Gas-Turbine Generator	6
3.	Concept of Parabolic Trough Solar Collectors Which Could Be Used With an Organic-Vapor Turbine Generator System	8
4.	Schematic View of Parabolic Trough Solar Collector With Organic-Vapor Turbine Generator	9
5.	Solar Photovoltaic Systems	11
6.	Schematic View of Solar Photovoltaic System	12
7.	Solar Pond	14
8.	Schematic View of Solar Pond System	15
9.	Conceptual Design of a Central-Tower Solar Steam-Electric Power Plant	16
10.	Schematic View of Solar Tower Steam-Electric System	17
11.	Three-Kilowatt Organic Rankine System Using a Radioisotope Heat Source	19
12.	Schematic View of Organic Rankine System Using a Radioisotopic Heat Source	20
13.	Experimental Horizontal-Axis and Vertical-Axis Wind Turbine Generator	22
14.	Three Wind-Turbine Generator Configurations	25
15.	Schematic View of Geothermal System	26
16.	Iron Redox Battery Structure and Plumbing Diagram	38
17.	One Kiloton Nuclear Overpressure Versus Range	45
18.	One Thousand Pound Conventional Bomb Overpressure Versus Range	45
19.	Areas of Damage for Various Weapons	48

TABLES

Table	Title	Page
1.	Wind Power System Characteristics	23
2.	Comparison of Alternate Energy Systems.	29
3.	Number of Sites with Fair to Good Alternate Energy Potential	31
4.	Load-Leveling Batteries: Candidates and Characteristics; Developers and Demonstration Dates.	36
5.	Probability of Direct Hit, Percentage	47
6.	System: Solar Gas-Turbine Generator.	60
7.	System: Solar Organic-Vapor Turbine Generator.	61
8.	System: Solar Photovoltaics.	62
9.	System: Solar Pond	63
10.	System: Solar Steam Turbine Generator.	64
11.	System: Gas Turbine Generator (Radioisotope Fuel).	65
12.	System: Wind Energy Conversion System (WECS)	66
13.	System: Geothermal	67
14.	System: Diesel Generator	68
15.	Decision Matrix	69
16.	Example of Use of Decision Matrix.	71

ABBREVIATIONS, ACRONYMS, AND SYMBOLS

A--area of turbine sweep	MPa--megapascal
AAC--Alaskan Air Command	MW--megawatt
AB--air base	MWh--megawatt hour
AC--alternating current	MWhth--megawatt hour thermal
ADCOM--Aerospace Defense Command	NASA--National Aeronautics and Space Administration
AFCS--Air Force Communications Service	O&M--operation and maintenance
AFS--Air Force station	P--power
AGB--Air Guard base	Pu--plutonium
APT--airport	RDF--refuse-derived fuel
As--arsenic	RRL--radio relay
AsH ₃ --arsine	SAFB--Scott Air Force Base
ASN--air station	SbH ₃ --stibine
BMEW--Ballistic Missile Early Warning	SPV--solar photovoltaic
BTU/hr--British thermal units per hour	USAF--United States Air Force
CEEDO--Civil and Environmental Engineering Development Office	V--wind velocity
CEP--circular error probable	VAWT--vertical axis wind turbine
Co--cobalt	WECS--Wind Energy Conversion System
COMM Site--Communication Site	W _p --peak watt
CONUS--Continental United States	Wx Stn--weather station
Cp--power coefficient	in--inch
DC--direct current	kW--kilowatt
DEW--Distant Early Warning	kW _e --kilowatt electric
DOE--Department of Energy	kW _p --peak kilowatt
EMP--electromagnetic pulse	kWth--kilowatt thermal
ETAC--Environmental Technical Application Center	kWh--kilowatt hour
FAA--Federal Aviation Agency	kWhth--kilowatt hour thermal
Ga--gallium	m--meter
GATR--ground air transmitter receiver	mi/h--miles per hour
GW--gigawatt (10 ⁹ watts)	mm--millimeter
HAWT--horizontal axis wind turbine	p--power
MEW--Middle Early Warning	redox--reduction/oxidation
	ρ--density

SECTION I
INTRODUCTION

The United States Air Force (USAF) maintains many remote sites around the world which vary in mission from the Aerospace Defense Command (ADCOM) Distant Early Warning (DEW) sites to Radio Relay (RRL) sites and which may require as little as 20 kW to several MW of electrical power. Most of these sites are powered by diesel generators requiring periodic fuel shipments and storage which are subject to escalating material and transportation costs and potential shortages of resources. The USAF is aware of these factors with respect to the continued operation of its early warning system and worldwide communications network. Therefore, the USAF is examining the possibility of supplying power to some of these bases with alternate energy (i.e., solar, wind, geothermal, etc.). The USAF also realizes the importance to alternate energy systems of low maintenance, good reliability, and survivability from a variety of threats, both natural and man made. The purpose of this report is to examine the use of alternate energy systems at remote USAF locations.

Section II will discuss certain energy systems as they may apply to these remote sites. This discussion will estimate the reliability and maintainability of the systems. Section III will examine energy storage techniques which are required for the continuous operation of an alternate energy system. An analysis of the survivability of these systems follows in Section IV in which the systems are studied with respect to natural disasters and offensive threats. Finally, a decision matrix is developed as a guide to the determination of the proper system for the proper site in terms of energy availability, reliability, maintainability, and survivability.

The diagnosis of the U.S. energy crises is quite simple: demand for energy is increasing, while supplies of oil and natural gas are diminishing. Unless the U.S. makes a timely adjustment before world oil becomes very scarce and very expensive in the 1980's, the nation's economic security and the American way of life will be gravely endangered. The steps the U.S. must take now are small compared to the drastic measures that will be needed if the U.S. does nothing until it is too late. (Reference 1)

-
1. *The National Energy Plan*, Executive Office of the President, Energy Planning and Policy. U.S. Government Printing Office, Washington, DC, Stock No. 040-000-00380-1, 1977, p. vii.

SECTION II ALTERNATE ENERGY SYSTEMS

INTRODUCTION

In general, an alternate energy system is an energy-producing system which does not use fossil fuels. In this report, eight such alternate systems were studied. These systems are either commercially available now or are being developed. They employ one of four types of fuel: solar, wind (really a derivative of solar energy), geothermal, or radioactive isotopes.

In all conventional systems (excluding hydroelectric and diesel generators), heat is generated from the combustion of fuel (oil, coal, natural gas, etc.) to produce high pressure steam, which, when expanded through a turbine, drives a generator to produce electricity. In an alternate energy system (excluding wind and photovoltaics), the sun, radioactive isotopes, or heat from the earth supplant the fossil fuel. The only unique component then is the heat source; the other components are proven and available.

A Wind Energy Conversion System (WECS) does not generate heat as a primary function but, rather, is analogous to a hydroelectric system. A hydroelectric system uses the kinetic energy of moving water to drive the turbine generator directly. A WECS uses the kinetic energy of moving air molecules to drive the generator. This more direct route of energy conversion avoids the inefficiencies in converting thermal to mechanical to electrical energy. Solar photovoltaics convert sunlight directly into electricity.

The alternate energy systems discussed in this section must be designed to replace the current energy source used in most remote sites--the diesel generator. The diesel generator also is atypical of a conventional power system in that it converts chemical energy to mechanical energy to electrical energy. The thermal energy it produces is a by-product. The diesel generator is a tough competitor when compared with an alternate energy system. It is state-of-the-art technology which has been proven. Some alternate energy systems are just now being developed; and although they, too, represent

state-of-the-art designs, there is little performance data available. In the discussions of the systems, expected development costs and schedules are given. The main advantage any alternate system has over the diesel generator is that fuel need not be transported in and that it is not depleted.

An alternate energy system which is used in a remote site may be subjected to an extreme climate. The weatherability of these systems may be enhanced if necessary. The drive motors for tracking collectors and bearings can be sealed against dust, and a light-weight lubricant can be used in arctic conditions. The systems requiring solar collectors must be cleaned periodically to avoid degrading optical performance. Snow is not normally a problem on solar collectors, although large snows could bury the collectors. Once the sun shines on a solar collector, the snow slides off, permitting normal operation. In extreme climates, modifications to the systems may be required. For example, ice formed on the blades of a wind turbine may be removed by implanting heating coils on the blades. Specific climate-related problems will require specific solutions, but these problems are not insurmountable.

Although Section III will deal with specific energy storage devices, a general storage device is mentioned with the systems discussed. These storage techniques are the typical devices associated with each energy system. A more detailed analysis of storage devices available now or which are being developed follows this section. The remainder of this section will discuss specific alternate energy systems. The basic system and components will be explained. Some specifications and a discussion of cost, maintainability, and reliability follow.

SYSTEMS

(1) Solar gas-turbine generator--A solar gas turbine generator is basically a parabolic dish solar collector employing an open Brayton cycle with air as the working fluid. One is depicted in Figure 1. Such a system is currently being studied at Sandia Laboratories in Albuquerque, New Mexico. A schematic of the system is given in Figure 2.

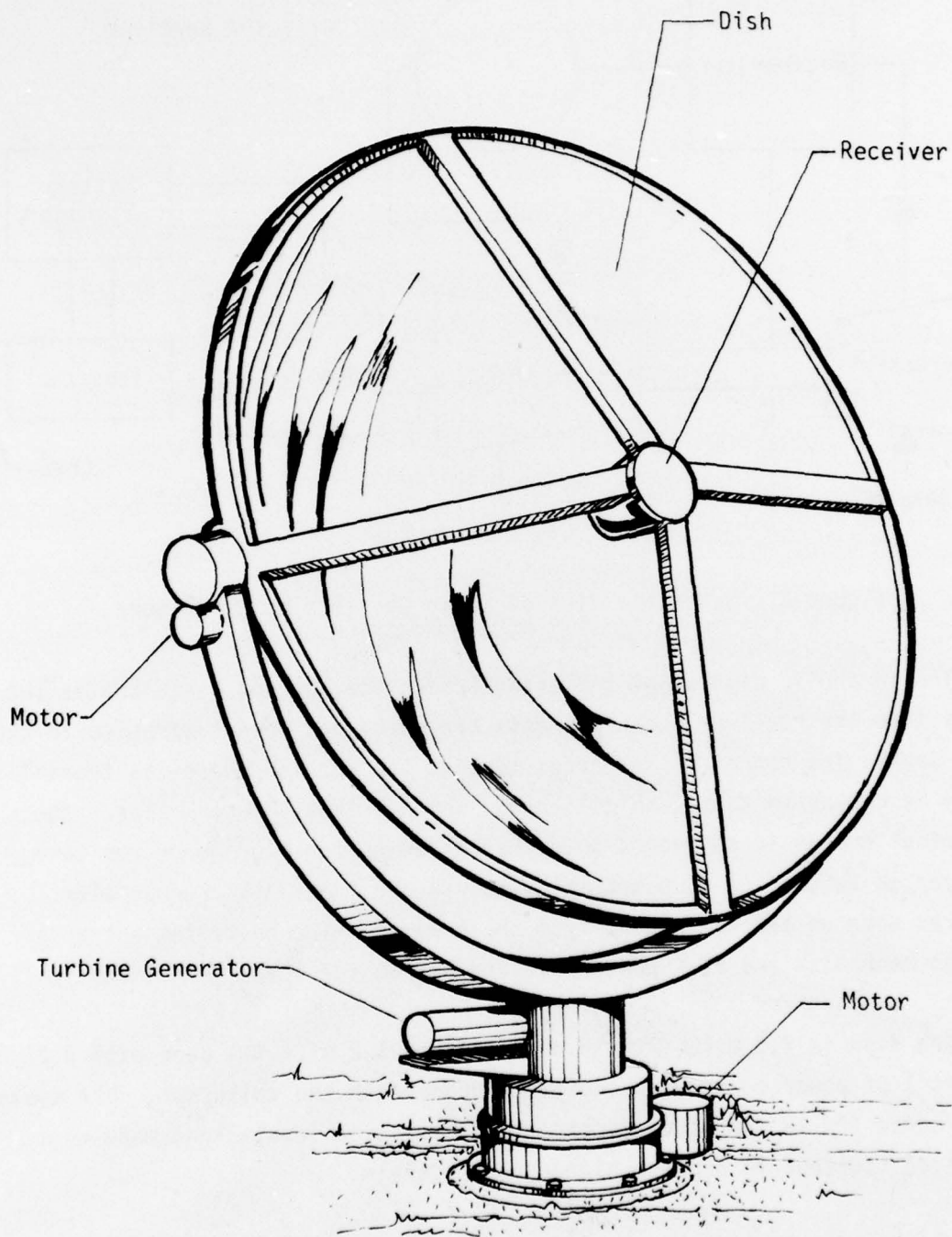

Figure 1. Concept of Individual Solar Gas-Turbine Power Module

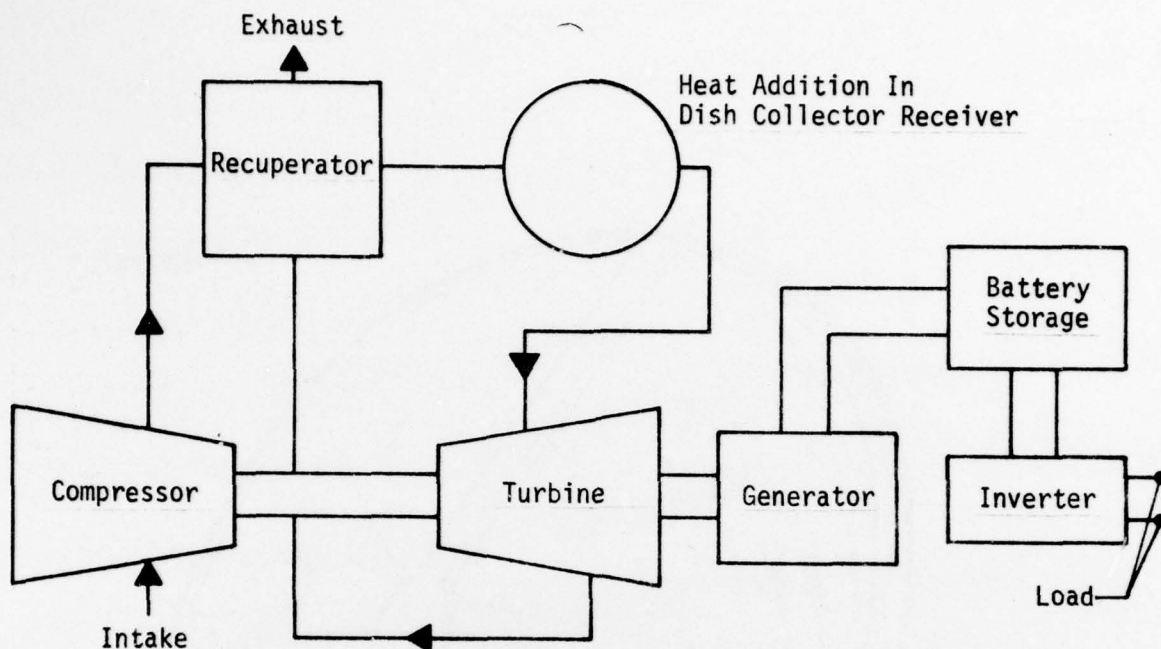

Figure 2. Schematic View of Solar Gas-Turbine Generator

The parabolic dish solar collector tracks the sun and concentrates the energy into the receiver where it heats air which has been compressed in the compressor. The hot air is expanded through the turbine where its thermal energy is converted to mechanical energy which drives the generator. The electrical energy is delivered into the batteries for storage or run through an inverter to produce AC electricity to run the load. The recuperator captures some of the waste heat from the exhaust. The batteries act as a storage mechanism and as a power-leveling system for a variable load.

The dish is 7.3 m (24 ft) in diameter and 1.2 m (4 ft) deep with 4.25 m³ (150 ft³) of power conversion equipment underneath the collector. The system can produce 100 kW_e or more, depending on isolation levels; and modules may be ganged together to produce higher power levels.

These units are expected to be available for purchase in 1980 at a cost of about \$61,000 (1977 dollars) for each module. The collector is expected to last about 30 years, although the Brayton cycle turbine generator will require refurbishment every 3 to 5 years. The lead-acid batteries will require

replacement approximately every 10 years. The overall system efficiency is about 15 percent.

The operation and maintenance (O&M) costs will be \$3,000 per year (1977 dollars). This is higher than conventional systems due to the fact that the collectors must be cleaned, aligned, and serviced periodically. This cost includes the Brayton cycle overhaul and battery replacement. Personnel are not required continuously for systems of lower power levels.

The system reliability is mainly a function of adequate insolation. If extra modules are employed, the reliability is enhanced. Adequate battery storage is necessary to supply power for inclement weather, or diesel generators could be used as a back-up system. Approximately 50,000 BTU/hr are available as waste heat which could be used to supply hot water or saturated steam.

(2) Solar organic-vapor turbine generator--A solar organic-vapor turbine generator system consists of an array of single-axis tracking parabolic trough collectors which heat an organic working fluid to drive a Rankine cycle organic vapor turbine. Figure 3 shows a field of collectors and control building similar to a system at Sandia Laboratories which is used to supply electricity, heating, and cooling for an office building. A schematic of the system is shown in Figure 4.

The parabolic trough collectors track the sun on one axis. The sun's energy is concentrated at the receiver tube where a fluid absorbs the heat. This heated fluid is pumped to a thermal storage tank. The energy is transferred by a heat exchanger to an organic fluid such as toluene, where it is vaporized. This vapor is expanded through a turbine which drives a generator. The vapor then goes through a regenerator to capture some waste heat and then is condensed to a liquid state, where it is pumped back to the heat exchanger. The generator generates electricity at the proper voltage and frequency for use by the load.

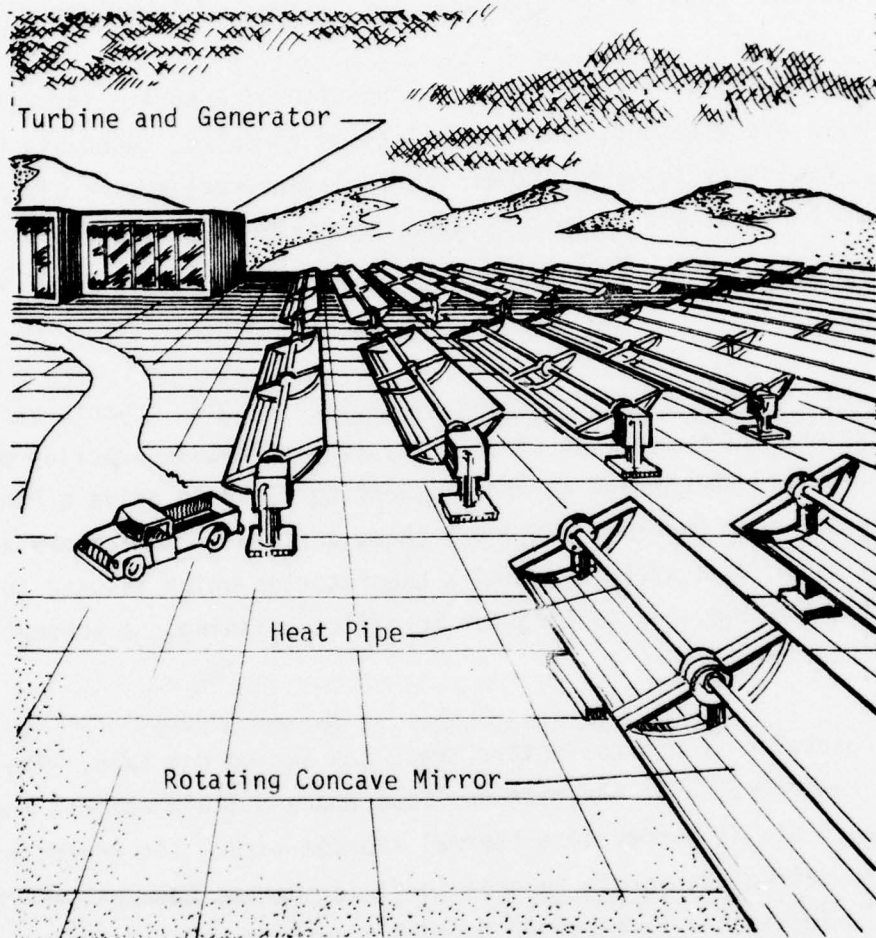

Figure 3. Concept of Parabolic Trough Solar Collectors Which Could Be Used With an Organic-Vapor Turbine Generator System

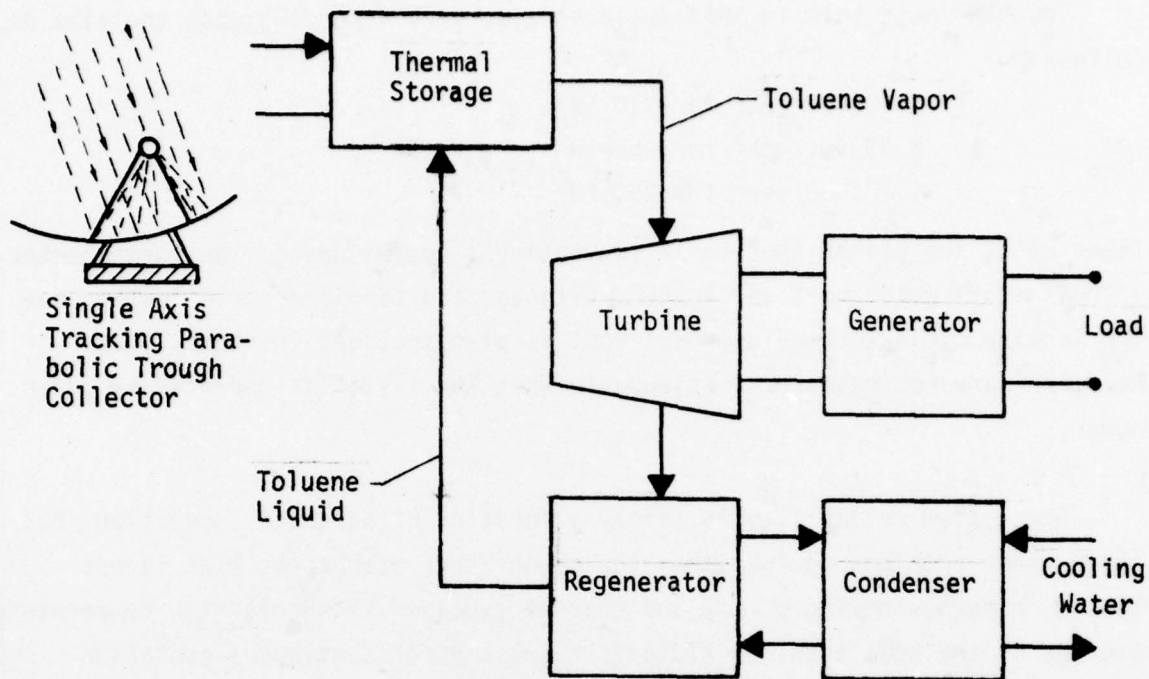

Figure 4. Schematic View of Parabolic Trough Solar Collector with Organic-Vapor Turbine Generator

The system can produce power up to 600 kW_e [a 600-kW Rankine cycle turbine is the largest power level being developed by the Department of Energy (DOE) at this time] and should be available in 1980. A smaller system may be designed to produce 10 kW_e ; and, as the entire system may be viewed as a module, it may be expanded. The annual electric output of the system is about $35 \text{ W}_e/\text{m}^2$ ($3.25 \text{ W}_e/\text{ft}^2$) of collector area in a southwest U.S. site.

The acquisition costs will vary depending on power delivered, but will break down as follows (in 1977 dollars):

\$ 850,000 for 10 kW_e
 \$1,400,000 for 50 kW_e
 \$2,600,000 for 250 kW_e

The life expectancy is 30 years, although the Rankine cycle turbine must be refurbished every 3 to 5 years. The overall efficiency of the system varies for the power produced from 8.5 percent to 10 kW_e to 14 percent for 600 kW_e .

The O&M costs (all in 1977 dollars) also vary depending upon the size as follows:

\$ 40,500/year for 10 kW_e
\$ 65,500/year for 50 kW_e
\$110,000/year for 250 kW_e

These costs are higher than for a conventional system due to the large number of collectors which must be cleaned, aligned, and serviced periodically; but the Rankine cycle turbine overhaul cost is also included in these figures. Personnel are not required continuously when the system is operated at lower power.

The system reliability is mainly a function of adequate insolation, but other minor problems include the high temperature operation, high stress levels, numerous moving parts, and thermal cycling. Adequate high-temperature storage of the heat transfer fluid is necessary for continuous operation during inclement weather, or diesel generators could be used for a back-up system. For each watt of electricity produced, 8 BTU/hr of rejected heat is available for low-pressure hot water.

(3) Solar photovoltaics--Unlike conventional solar collectors which convert the sun's radiant energy into thermal energy, a solar photovoltaic cell directly converts the sun's energy into DC electricity. The output from a cell is a function of the concentration ratio of the sun and the tracking mechanism of the array (flat panel, one- or two-axis tracking). Figure 5 shows photovoltaic arrays with one- or two-axis or no tracking. The system schematic is shown in Figure 6.

The photovoltaic collector produces electricity which is run through a regulator. From the regulator, the electricity is either stored in batteries, used directly in DC loads, or inverted and used in AC loads. The batteries also smooth out the power during cell shadowing, etc. Silicon cells must be cooled to prevent cell failures and to increase efficiency. This cooling may be done passively by natural convection or actively by forced convection.

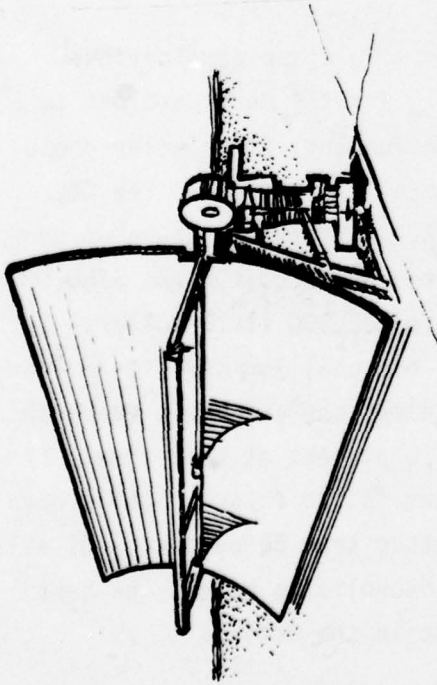

Parabolic Trough Collector
(Single-Axis Tracking)

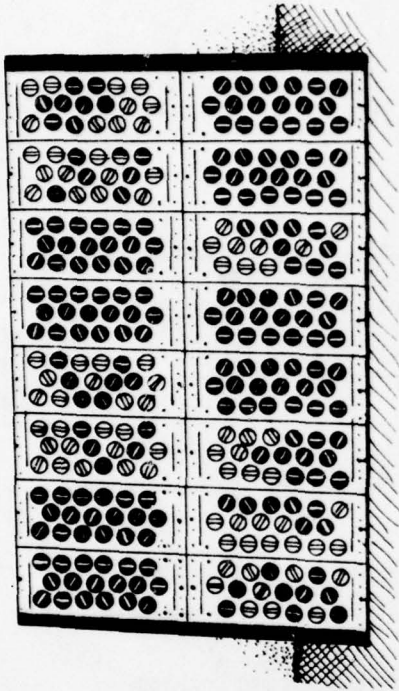

Flat Panel Collector
(Non Tracking)

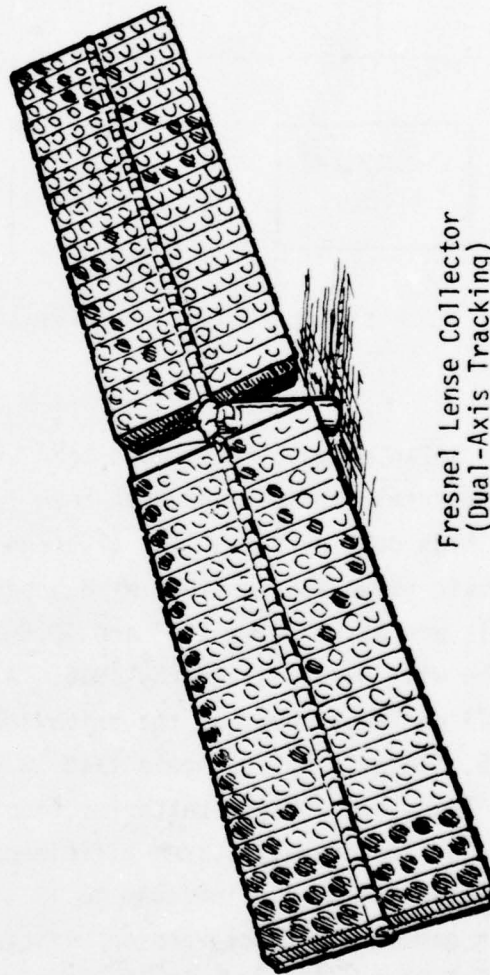

Fresnel Lens Collector
(Dual-Axis Tracking)

Figure 5. Solar Photovoltaic Systems

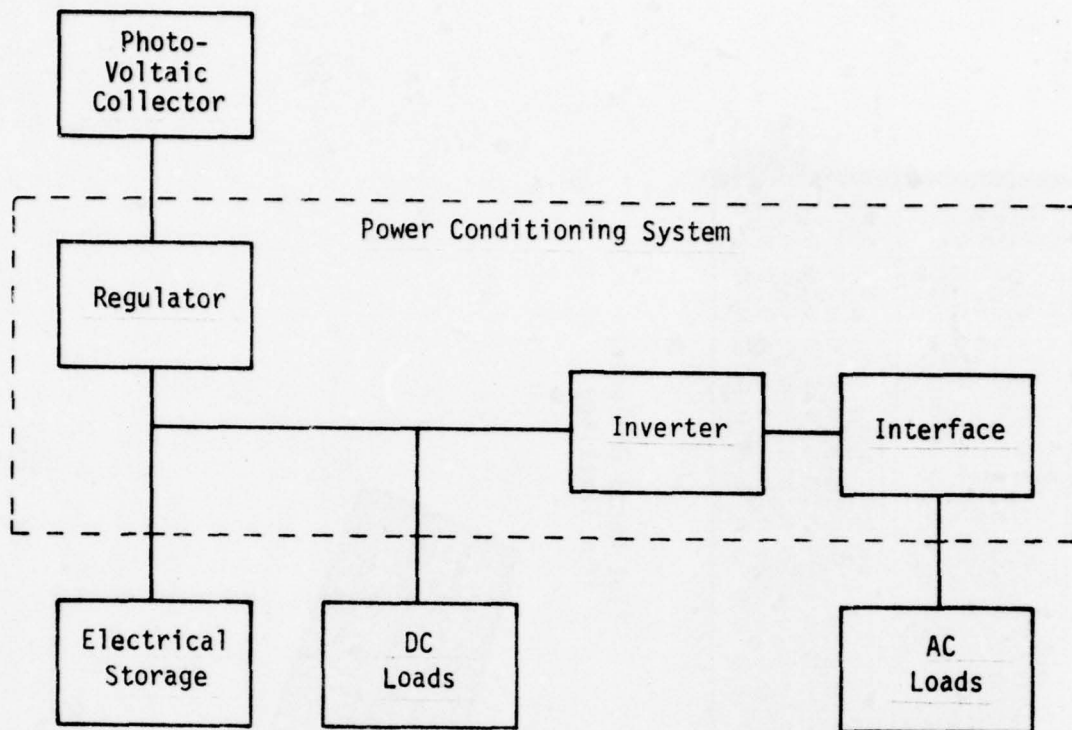

Figure 6. Schematic View of Solar Photovoltaic System

Solar photovoltaics have been used for years in space applications. Terrestrial applications have been few and small for the most part due to the high cost of the cells, although the DOE is funding larger solar photovoltaic (SPV) applications with hopes of major cost reductions. The DOE goals are $\$2.00/W_p$ by 1982 and $\$0.50/W_p$ by 1986. Systems producing up to 50 kW will be available by 1986. A 10 kW system would cost about \$750,000 (1977 dollars) now, but the price should drop to \$32,000 (1977 dollars) by 1995. Today's cells should last 10 years, and the goal for 1995 is 20 years. The lead-acid storage batteries require replacement approximately every 10 years. The overall system efficiency is 5 to 10 percent at this time. Efficiencies should increase to 10 to 15 percent in the future. Cells have been produced with conversion efficiency of better than 25 percent. Of all the alternate energy systems studied, solar photovoltaics offers the best chance for increased performance at lower costs in the future.

The O&M costs for a 10-kW system are about \$35,000/year (1977 dollars), but they are expected to drop to \$3,500/year by 1995. The arrays must be cleaned, serviced, and aligned (if a tracked array) periodically which causes the high O&M costs. Personnel would not be required for a 250 kW or smaller system.

The reliability of the system is dependent on adequate insolation, and there are minor problems due to corrosive attack and high temperature operations (if not actively cooled). The battery storage must be adequate to cover demands during periods of inclement weather. Back-up would consist of other power sources (e.g., diesel generators) for direct use and/or battery recharge. If the cells are actively cooled, adequate heat is available for low-grade hot water production or space heating.

(4) Solar pond--A salt gradient solar pond can collect 15 percent of the incident solar radiation and store it for long periods. Normally, a body of water collects a large amount of the sun's energy; but due to convective circulation, the energy is transported to the surface and lost. If the pond (Figure 7) has a nonuniform vertical distribution of salts that prevent convection, it can trap a substantial amount of energy at the bottom.

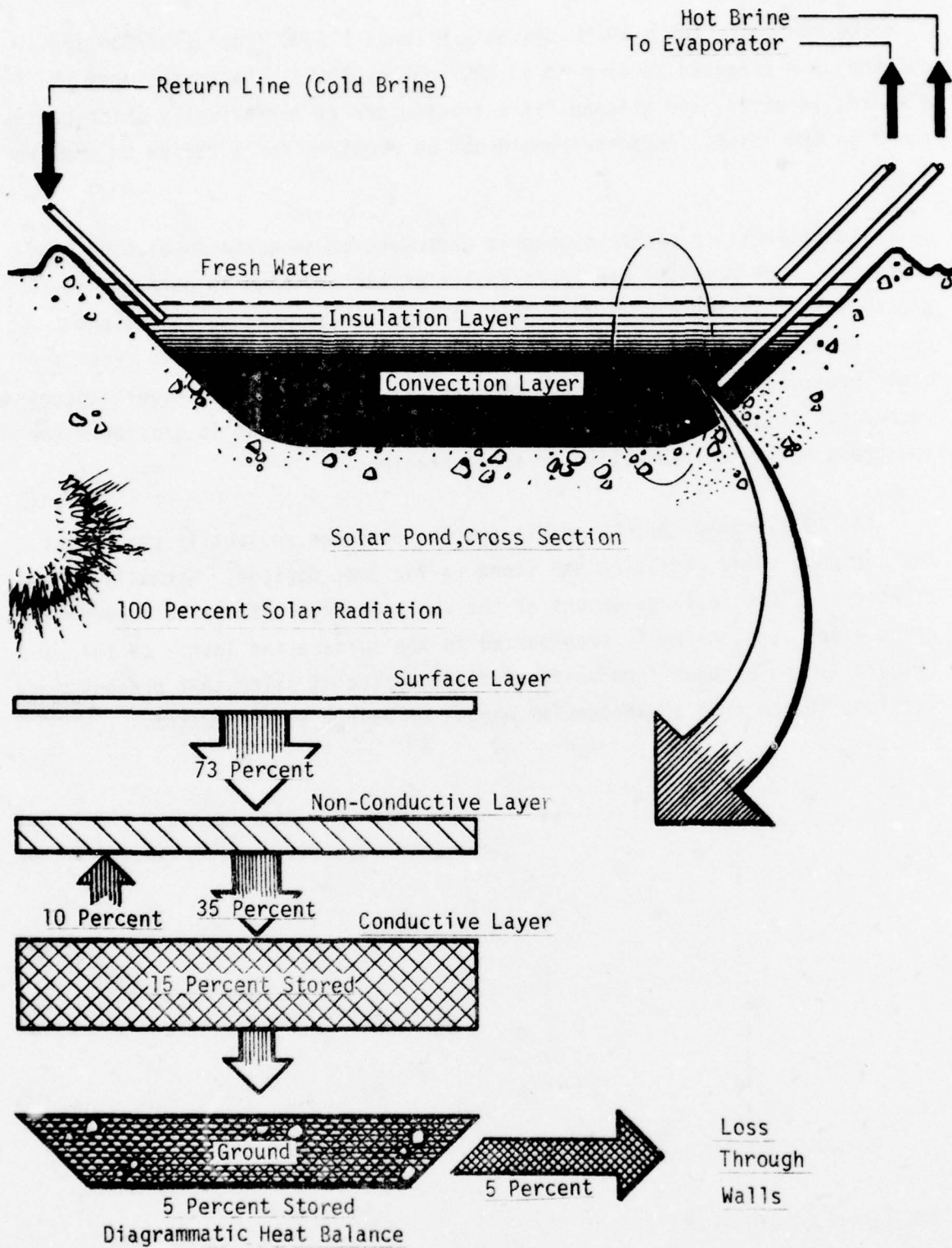

Figure 7. Solar Pond

The increase in density, due to the presence of the salts, counters the thermal expansion effects due to local heating. If the heat is drawn out of the bottom, it can be used to run a turbine generator as shown schematically in Figure 8.

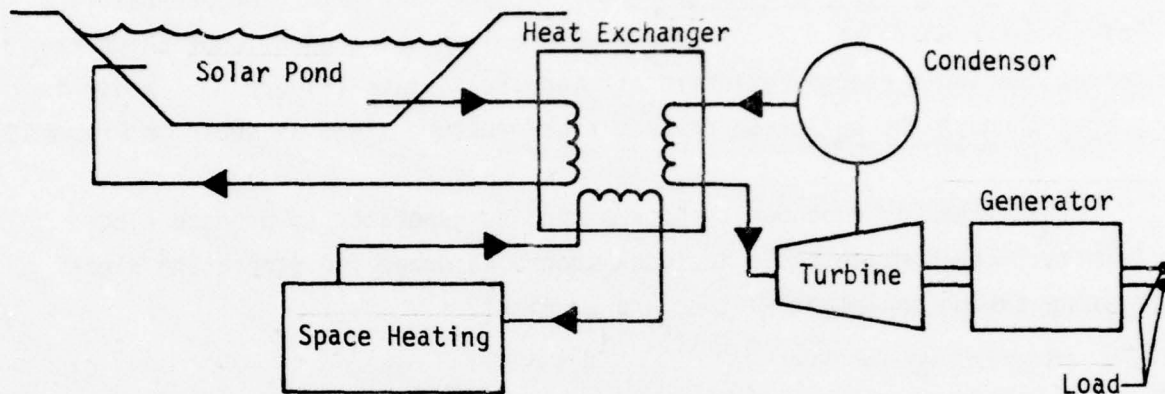

Figure 8. Schematic View of Solar Pond System

Heat may also be drawn off to be used in space heating or hot water production. For a 1 km^2 (0.39 mi^2) pond, approximately 3.4 W/m^2 (0.32 W/ft^2) of electricity may be produced, providing there is adequate insolation available. The solar pond is being studied mainly as a source of low-grade heat for space heating and domestic hot water, but some research is going on to use the solar pond for electrical production. The efficiency of a solar pond for heating is about 10 percent, but the efficiency for electrical production drops to 1.5 percent overall. The pond should last indefinitely with proper maintenance. The heat exchanger and turbine would require periodic maintenance.

The cost of a solar pond and related equipment to produce 250 kW_e would be about \$1,000,000 (1977 dollars). A substantial amount of development is required. For heating requirements, the cost would be much lower. In a typical southwest U.S. application (Albuquerque, NM) 1 m^2 (9.30 ft^2) of the University of New Mexico's solar pond can heat 1 m^2 (9.30 ft^2) of living space.

The O&M costs for electrical production would be \$50,000/year (1977 dollars). Again, for space-heating applications, the cost is much lower. The

start-up time on a solar pond is very long (6 months), but it is fairly insensitive to periods of inclement weather. Thus, the reliability is good as long as the pond is not overworked (i.e., too much heat withdrawn). The weak link would be a generator failure in which case back-up would be required.

(5) Solar steam-turbine generator--A solar steam-turbine generator (often referred to as a *power tower*) is a boiler set atop a tower which receives the sun's energy reflected off many heliostats (Figure 9). Water is pumped through the boiler to produce high-pressure steam as shown in Figure 10.

This steam is expanded through a turbine generator to produce electricity. The Rankine cycle includes thermal storage for generating electricity during inclement weather and at night.

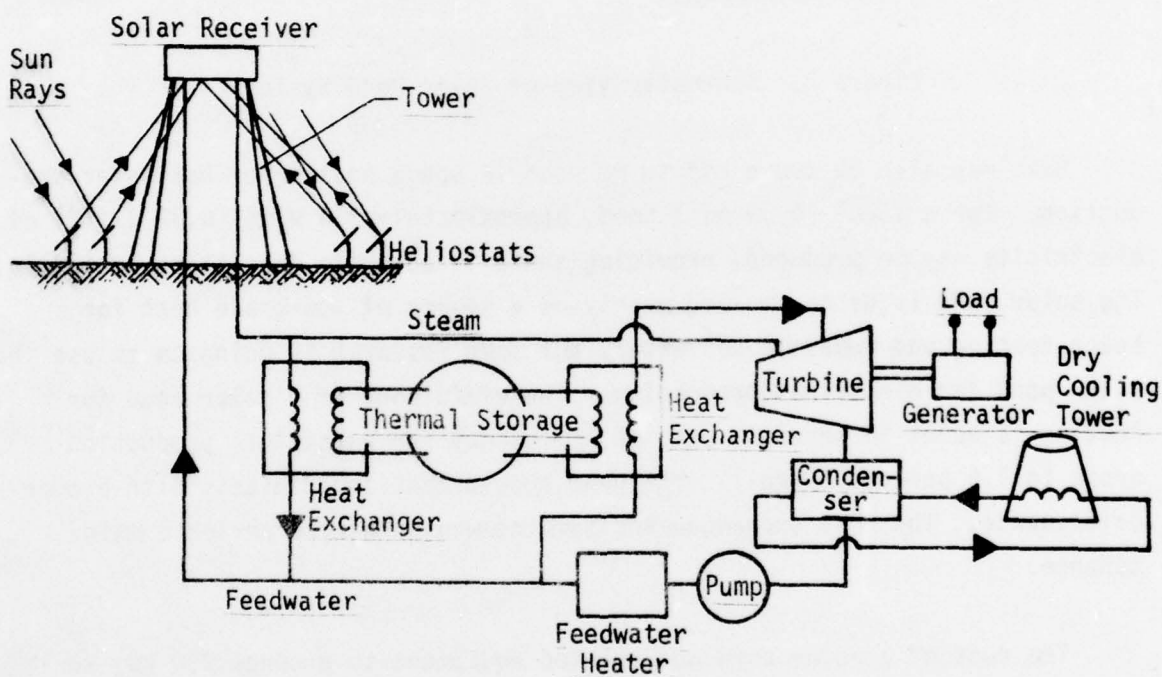

Figure 10. Schematic View of Solar Tower Steam-Electric System

The use of power towers is being studied in the United States under DOE funding for production of electric power. A 5 MW_{th} test facility is testing boilers at Sandia Laboratories, and a 10 MW_e facility is planned for Barstow, California. As smaller units (to 100 kW_{th}) have been studied in Europe, it

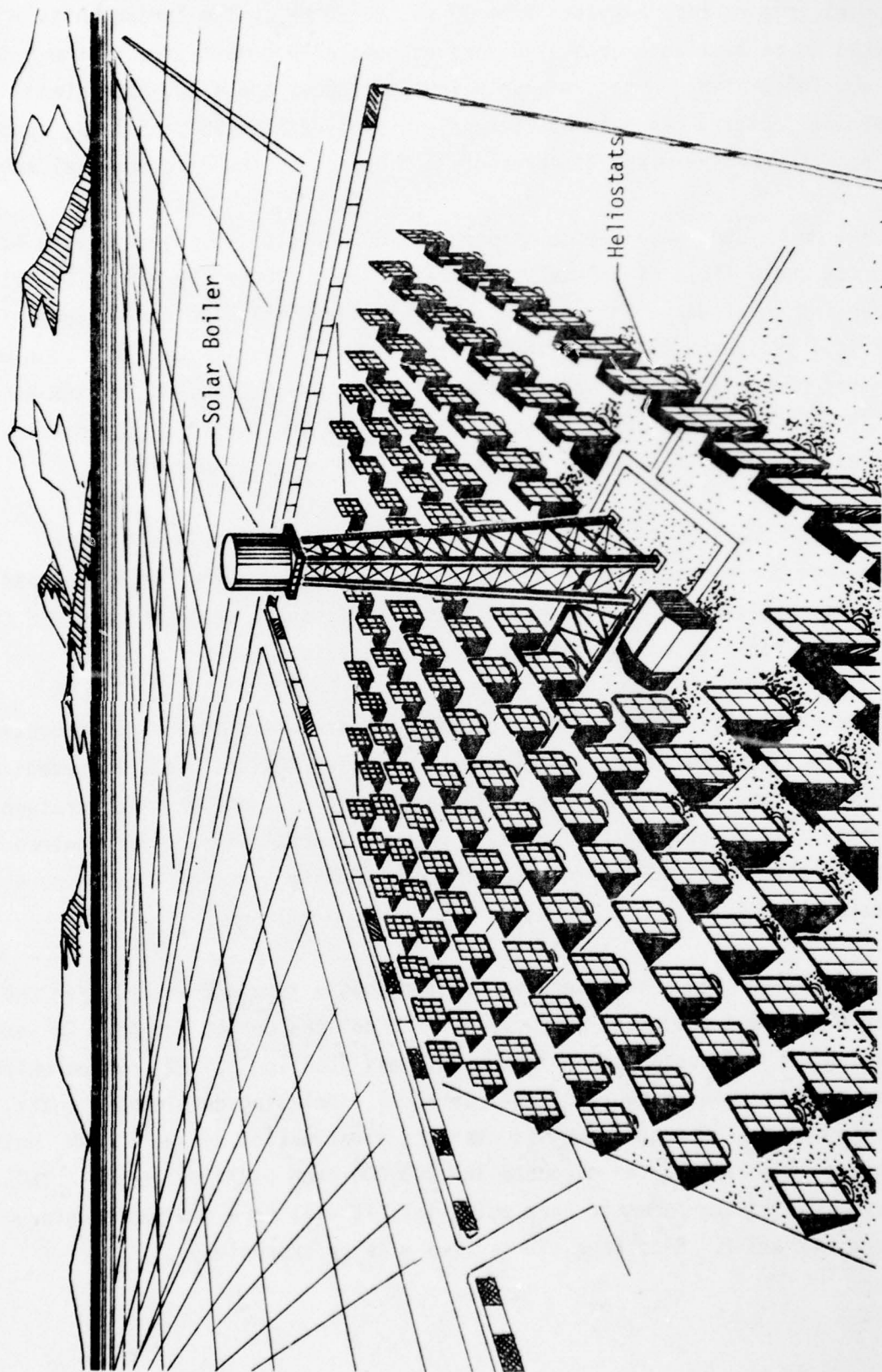

Figure 9. Conceptual Design of a Central-Tower Solar Steam-Electric Power Plant

is conceivable to size a system from 30 kW_e to 50 MW_e. The larger units are expected to be available about 1985 and economically competitive by the 1990's. The smaller units are also being developed, and a 100 kWth steam-generating facility has been operational in Italy since 1967. A 1 MW_e system will be discussed here as it represents a midpoint in the developmental area.

A 1 MW_e system would be comprised of a 50.3 m (165 ft) tower with a boiler on top and a field of 250 heliostats each 7.6 m (25 ft) by 7.6 m (25 ft) surrounding the tower. The rest of the system is similar to conventional electrical producing power stations currently using fossil fuels for heat except that provisions would be made for thermal storage. A 1-MW_e system would cost \$5,000,000 (1977 dollars) and should last 30 years with proper maintenance. The overall system efficiency would be about 15 percent.

The O&M costs would be \$200,000/year (1977 dollars). This is much higher than for a conventional system due to the large number of heliostats requiring servicing, cleaning, and aligning. Personnel would be required to operate the facility and to maintain the heliostats.

The reliability is a function of several parameters including adequate insolation, numerous moving parts, and non-modular design. Less important are thermal cycling, corrosive attack, high stress levels, and high-temperature operation. If no back-up is supplied, a large thermal storage is required. Approximately 5,000,000 BTU/hr is available as waste heat for low pressure hot water.

This system requires extensive development in time and money. For the larger DOE-funded projects, over one billion dollars during the next 12 years is needed. The European Economic Community is studying a 1 MW_e system which is expected to cost \$8,500,000 (1977 dollars), including development costs. The International Energy Agency is planning construction of two 500-kW_e units using liquid sodium for an expected \$25,000,000 each (1977 dollars). Thus, although the system seems to have potential, it will be a few years before it becomes available. Even then, it is likely to be expensive.

(6) Radioisotope-fueled gas turbine generator--A radioactive isotope-fueled gas turbine generator is similar to the solar gas-turbine generator discussed above except that it uses radioactive isotopes for a heat source and a closed rather than open Brayton cycle (Figure 11). A schematic is shown in Figure 12.

The radioisotope fuel heats the working fluid (an inert gas mixture), which is then expanded through the turbine, which drives the compressor and generator. The working fluid then enters the recuperator where some of the rejected heat is recovered. The fluid is cooled next and then pumped back through the heat source. Many types of isotopes may be used for the heat source, but only Cobalt 60 (Co^{60}) and Plutonium 238 (Pu^{238}) are discussed here.

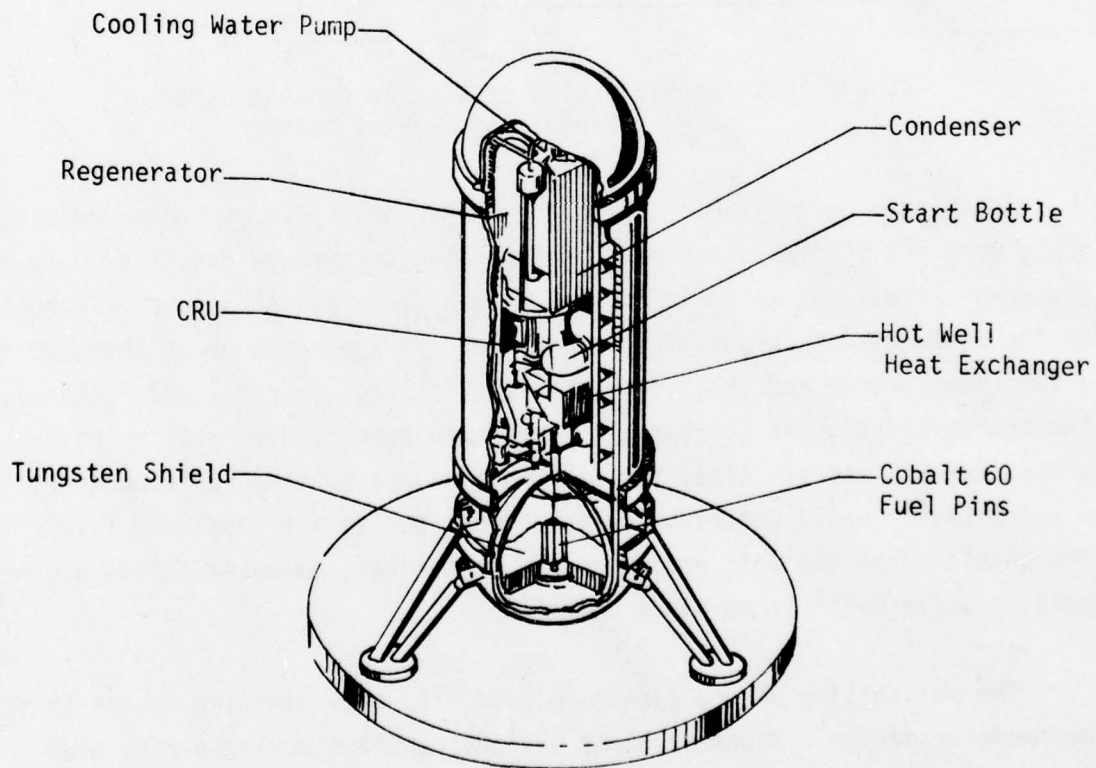

Figure 11. Three-Kilowatt Organic Rankine System Utilizing a Cobalt 60 Radioisotope Heat Source

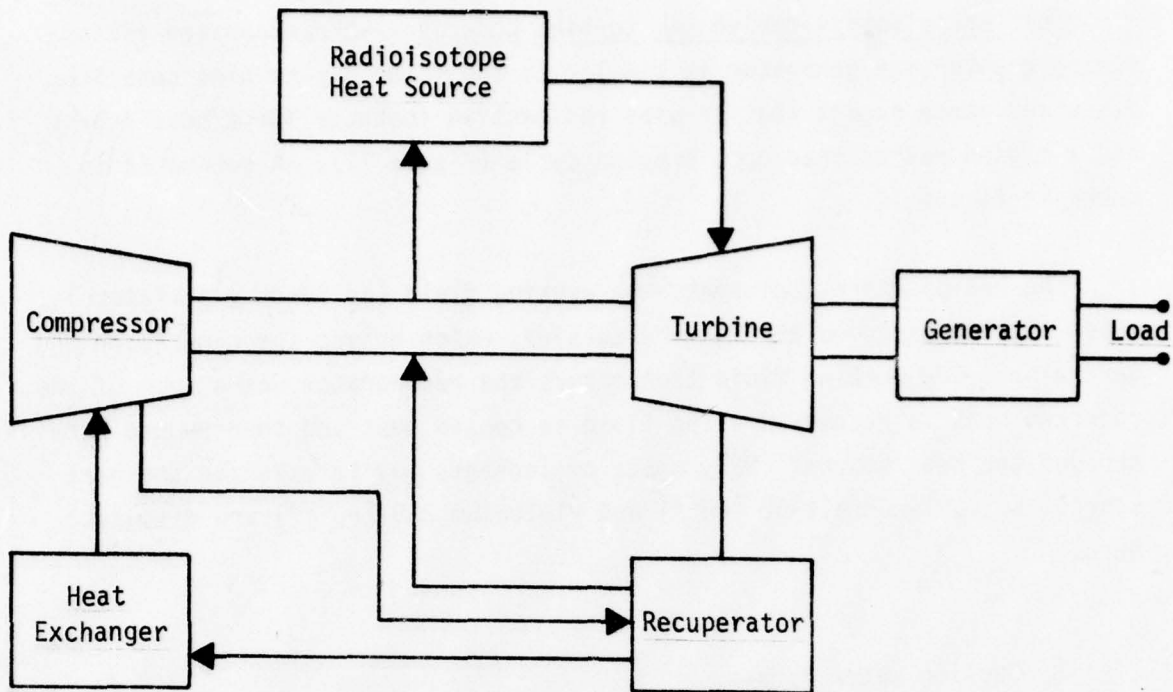

Figure 12. Schematic View of Organic Rankine System Using a Radioisotopic Heat Source

Achievable power levels are in the 10-kW range. Larger power requirements were not studied since radioisotopes are considered practical only for low power levels due to their limited availability and high cost. Technology in the 10-kW size is presently available at a system cost of \$5,500,000 for a Co^{60} heat source and \$27,300,000 for a Pu^{238} heat source (1977 dollars). The system lifetime is 20 years, although the power system must be refurbished every 5 years. Also, the Co^{60} heat source must be replaced every 5 years (Pu^{238} would not require replacement due to its long half-life). The shielding on the Co^{60} would need to be thicker, because Co^{60} is a gamma emitter while Pu^{238} is an alpha emitter.

The reliability of the system is good. Its main limiting factor is its non-modular design. Minor problems include numerous moving parts, high temperature operation, high stress levels, thermal cycling, and a high radiation level. A back-up system would consist of another unit or diesel generators. There is 53,000 BTU/hr waste heat available for low temperature hot water. The radioisotope heat source generates heat continuously, regardless of whether electricity is produced.

The use of Pu^{238} and CO^{60} as heat sources has been employed in space program applications. Ten-kW Brayton cycle power systems have also been developed, but there is a need for further development over a three-year period costing \$30,000,000. Although the costs of this system are high, it might be useful in a small unmanned site.

(7) Wind energy conversion systems (WECS)--A wind energy conversion system converts the kinetic energy in moving air molecules into rotational mechanical energy, which drives a generator to produce electricity. There are two basic types of WECS: a horizontal axis wind turbine (HAWT), in which the wind turbine axis is horizontal, and a vertical axis wind turbine (VAWT), in which the axis is vertical (Figure 13). The DOE is funding large-scale wind energy research through NASA (for HAWTs) and Sandia Laboratories (for VAWTs). NASA has built a 200-kW HAWT [in a 10.7 m/s (24 mi/h) wind] at Clayton, New Mexico; and Sandia Laboratories has constructed a 60-kW VAWT [in a 12.5 m/s (28 mi/h) wind]. Many smaller WECS are available commercially, and a few larger WECS are also commercially available. Table 1 presents the wind turbine characteristics of both a Darrieus turbine (a VAWT--named after the French inventor) and a propeller-type turbine (a HAWT). Because the VAWT need not face into the wind and because it is available in many sizes, this discussion will focus on the VAWT.

The amount of power a wind turbine can produce depends on four variables: (1) the area of turbine sweep, (2) the speed of the wind, (3) the density of the air, and (4) the power coefficient of the turbine (turbine efficiency). These factors are related by the formula:

$$P = C_p \rho A V^3$$

where P = power
C_p = power coefficient
ρ = air density
A = area of turbine sweep
V = wind speed.

It can be seen that the wind speed is the most important parameter because it is cubed. Therefore, the power available is limited mainly by the wind speed at the site.

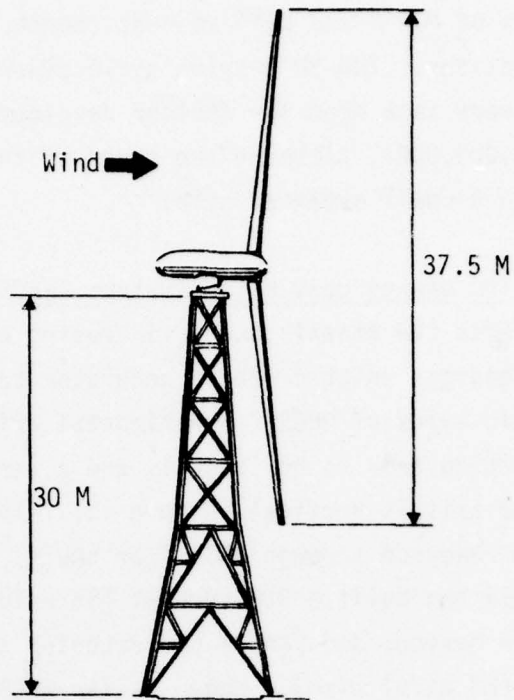

a. DOE-NASA Experimental Horizontal-Axis Wind Turbine Generator--100-kW Test Generator--100-kW Test Bed

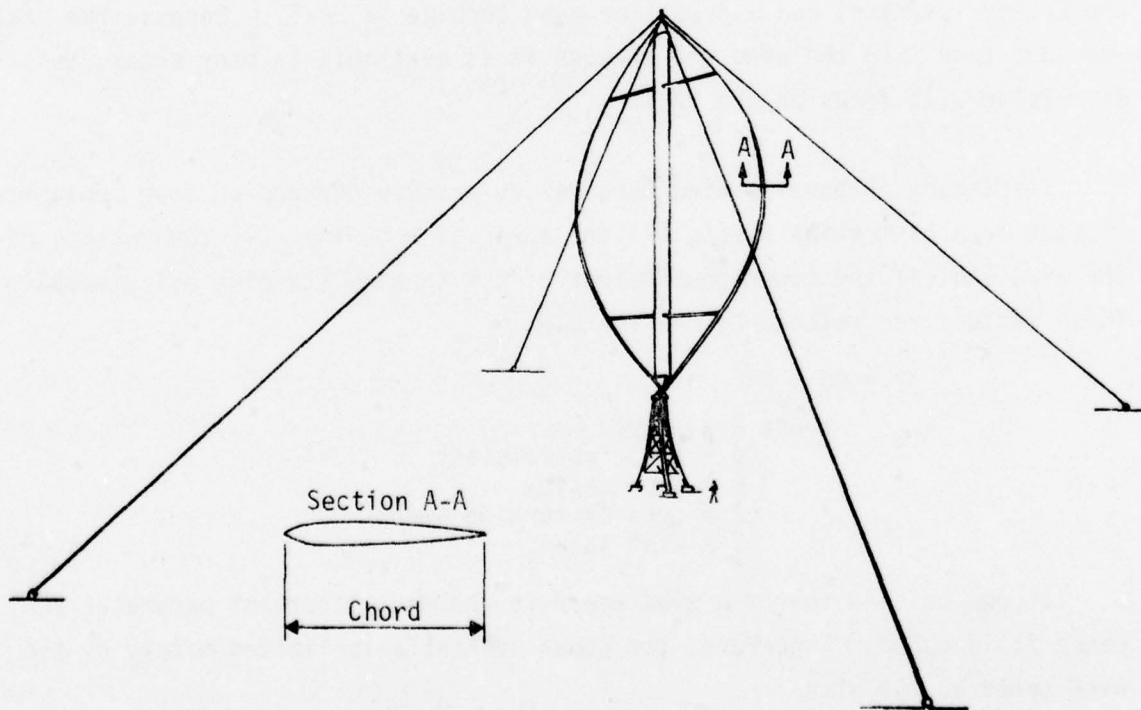

b. Experimental 200-Kilowatt Vertical-Axis Wind Turbine Generator
 Figure 13. Experimental Horizontal-Axis and Vertical-Axis Wind Turbine Generators

TABLE 1. WIND POWER SYSTEM CHARACTERISTICS

VAWT	HAWT
Can operate with wind from any direction	Requires motored yaw control to face wind
Moderate power coefficient .35	High power coefficient .45
Non-self starting	Self starting
Power delivered at ground level (easy accessibility)	Generator mounted atop tower (difficult accessibility)
Lift type (High efficiency)	Lift type (high efficiency)
Simple controls	Complex controls
Low cost	High cost
Blade balance important	Blade balance important
Will withstand wind gusts up to 170 mi/h	Spoiler required for high speeds
Simple blade design/fabrication	Complex blade design/fabrication
Simple support structure	Large support structure
Low stressed blades, bearings and structure	High stressed blades, bearings and structure

Wind turbines may be used to generate AC electricity or DC electricity with battery storage as shown in Figure 14. The turbine drives the generator to produce electricity (DC or AC). If a synchronous AC generator is used, the AC electricity may be used directly. If DC electricity is produced, it must be converted to AC; or it can be used directly out of a regulator. The batteries are used for storage and power leveling during unsteady winds.

The size of the turbine is related to the average wind speed and power requirements, but a power level of hundreds of kW is not an uncommon design parameter. An array of turbines may also be used to increase the power produced.

Because the power produced is a function of wind speed and turbine size, the cost of the turbines will vary. Based on a 50-kW system with five days of storage, pricing in 1977 dollars is given below:

10 mi/h average wind speed--\$600,000

20 mi/h average wind speed--\$200,000

A WECS should last 20 years, although the lead-acid storage batteries require replacement every 10 years. The overall system efficiency is 20 to 25 percent. The O&M costs are low: about \$1,500/year (1977 dollars) for a 50-kW system, most of which is maintenance of the battery storage system. Personnel would not be required as a small computer can run the entire system.

The reliability of the system hinges upon adequate wind availability. High-stress levels in the WECS is another problem; minor problem areas include corrosive attack, high temperature levels, and numerous moving parts. Adequate battery storage would be required for periods of low winds, or diesel generators could be used for back-up and/or battery recharge.

The development of large-scale WECS is funded by the DOE, but commercial units capable of generating up to 200 kW are available.

Configuration Number 1 - Large Requirements

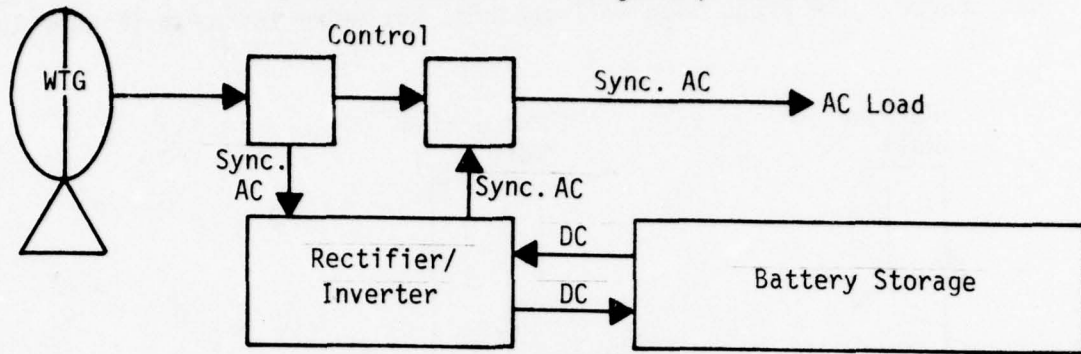

Configuration Number 2 - Small Requirements--AC Loads

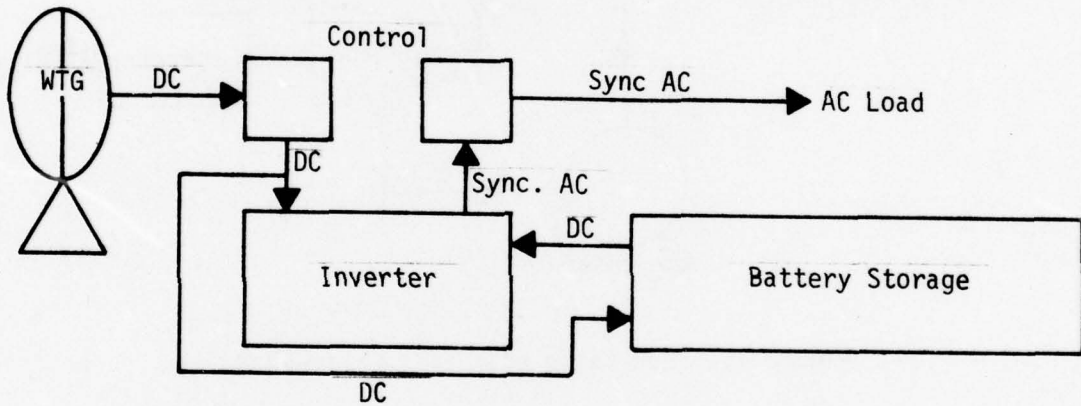

Configuration Number 3 - Small Requirements--DC Loads

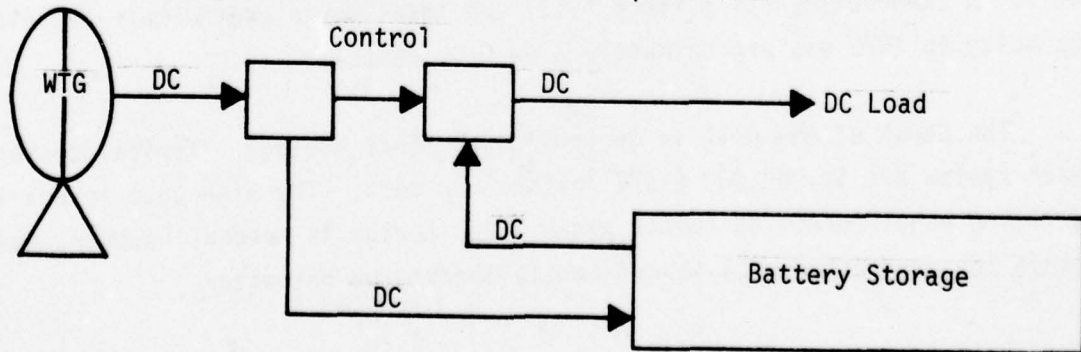

Figure 14. Three Wind-Turbine Generator Configurations

(8) Geothermal--A geothermal system uses natural subterranean heat as a heat source. The production well produces hot water or steam (Figure 15).

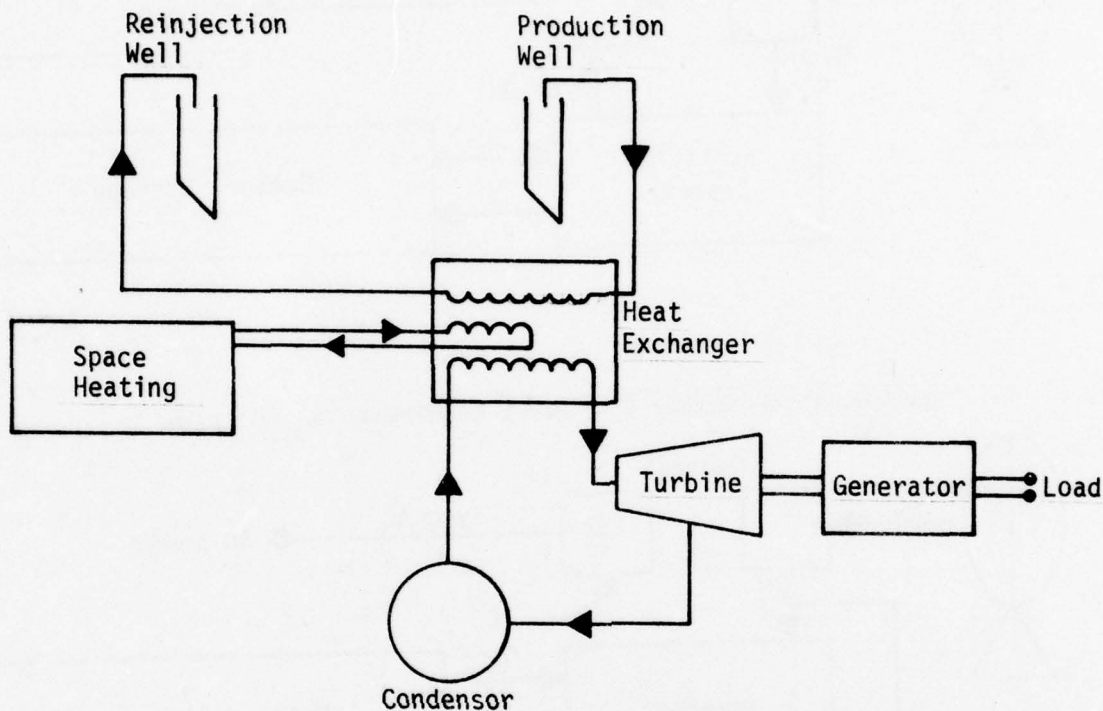

Figure 15. Schematic View of Geothermal System

A heat exchanger is used to heat the working fluid which runs a rotary vane turbine to generate electricity. Waste heat may be used for domestic hot water or space heating. The water is then reinjected into the earth through the reinjection well. Electricity has been produced from geothermal wells in Landerello, Italy since 1913; and total world geothermal electrical capacity in 1972 was approximately 1 GW (10^9 watts).

The depth of the well is controlled by local geology. Typical costs for each system are \$2,000,000 (1977 dollars) or more. The high cost is due to drilling requirements at remote sites. No storage is needed, however, because the production well is constantly sending up hot water.

The O&M costs are low (\$5,000/year in 1977 dollars). The rotary vane expanders must be inspected every 6 to 12 months and replaced every 5 years. The overall efficiency is about 12 percent.

The reliability of the system is good, limited by adequate production from the well. Corrosive attack may be a major problem depending on the local geology, and high-temperature operation may be a minor problem. Some high-grade heat is available for space heating and hot water.

There is substantial risk in drilling a well which does not produce. This risk and large initial cost must be weighed against the reliability and low operational costs.

(9) Other systems--A few other systems were studied for this report. Some, such as nuclear fission, were not studied in depth due to their size, cost, or associated problems. One type of fuel studied was refuse-derived fuel (RDF). The heating value of RDF can be 11,000 BTU/kg (5000 BTU/lb) [the heating value of coal runs from 27,500 BTU/kg (6000 to 12,500 BTU/lb)]. It can be seen that RDF has a potential if there is enough refuse available.

The USAF Civil and Environmental Engineering Development Office (CEEDO)* carried out a survey of USAF installations to determine the amount of refuse generated. Of the remote sites reporting, all indicated less than five tons/day of refuse (the smallest category). Assuming a 30 percent conversion efficiency for electrical production, five tons/day could produce 180 kW_e. It is doubtful though that a small remote site produces 4545 kg (10,000 lb) of refuse each day. A larger site might be able to generate enough refuse to be a viable fuel, but a small site could not.

Other systems which were studied include biomass (a small remote site could not generate enough biomass to be practical), fuel cell (requires fuel

* Now Air Force Engineering and Services Center (AFESC).

shipments) and thermionic generator (very expensive). A solar thermal system (heat production) was also studied, but the main problem faced in remote sites is production of electricity.

COMPARISON

An overall comparison of the systems is given on Table 2. This table shows various parameters of the systems discussed. The diesel generator is also included for comparison. The systems presented represent various producing capabilities, and care should be exercised when rating one system against another. The applicability of various systems in various sites will be controlled by many factors, mainly the availability of alternate fuels (solar, wind, etc.). The mission of the remote site as well as power level, manning, threats, and location are also constraints.

Table 3 shows the number of remote sites in each category which show good or fair alternate energy potentials. There are 109 sites which show at least fair potential (some sites have both solar and wind potentials). (Because weather data was not available on all the identified remote sites, this table is not complete.) Some of these sites may prove not to have good potential when a site study is done because of site configuration, terrain, and because much of the weather data are approximations. Still there are enough sites with potential for further study.

	Solar Gas Turbine Generator 250 kW _e System	Solar Organic Vapor Turbine Generator 250 kW _e System	Solar Photovoltaics 250 kW _e System	Solar Pond 250 kW _e System	Solar Steam Turbine Generator 1 MW _e Power Tower	Wind
System Consists of	A. Dish Collector with Tracking Mechanism and Heat Receiver B. Thermal Transfer Loop C. Open Cycle Gas Turbine (Including Turbine, Compressor, and Recuperator) D. Generator E. Power Conditioning Equipment	A. Parabolic Single-Axis Tracking Trough Collectors B. Turbine Generator Building and Control Room C. Cooling Tower and Pumps D. High Temperature Storage Area	A. Photovoltaic Cells in a Collector (Flat Plate or Concentrator with One-or Two-Axis Tracking) B. Power Conditioning Equipment C. Battery Storage	A. Pond with Plastic Liner B. Brine Solution C. Building Housing the Pumps, Heat Exchangers, Turbine Generator	A. 165-ft Power Tower with Boiler on Top B. Field of 250 Heliostats C. Building Containing Heat Exchanger, Turbine Generator, and Controls D. Thermal Storage	A. Wind B. Tower C. Control D. Battery E. Power
Power Produced	10-to-30 kW/24-ft Diameter Module. Connected in Parallel for Increased Power	36 W _e /m ² in a Typical Southwestern United States Application	Dependent upon Tracking Mechanism and/or Concentration Ratio. Up to 20 W _e /m ² in a Typical Southwestern U. S. Application	3.4 W _e /m ² Over One Year for a 1 km ² Pond	1 MW _e	$P = C_p V^3$ where $C_p = \frac{A}{A_0}$ $C_p = \frac{A}{A_0}$
Location Constraints	Adequate Insolation	Adequate Insolation Cooling Water Required	Adequate Insolation	Adequate Insolation Water Required	Adequate Insolation Cooling Water Required	Adequate
Efficiency	15 Percent	10 Percent	5-to-10 Percent	1.5 Percent for Electrical Production 10 Percent for Thermal Uses	15 Percent	
Lifetime	30 Years on Collector 10 Years on Batteries	30 Years	10 Years on Cells 10 Years on Batteries	Indefinite for the Pond 5-to-10 Years for Pumps and Heat Exchange	30 Years	20 to 30 Years
Acquisition Cost*	\$1,500,000.00	\$2,000,000.00	\$15,000,000.00 (1977) \$ 2,500,000.00 (1985) \$ 750,000.00 (1995)	\$1,250,000.00	\$5,000,000.00	\$1,000,000 Wind Speed Day Storage
Maintenance and Operations Cost*	\$90,000.00/Year. Higher Than Conventional Power System Due to Collectors Requiring Cleaning, Aligning, and Servicing. Brayton Cycle Turbine Requires Overhaul Every 3-to-5 Years. Batteries Replaced Every 10 Years	\$110,000.00/Year. Fairly High Due to Many Moving Parts, Cleaning, Aligning and Servicing of Collectors, Organic Rankine Cycle Turbine must be Refurbished Every 3-to-5 Years	\$ 750,000.00 (1977) \$ 130,000.00 (1985) \$ 75,000.00 (1995) Higher than Conventional System Due to Cleaning, Aligning, and Servicing Arrays	\$50,000.00/Year. Regular Maintenance of Turbine Generator, Cleaning and Servicing of Pumps and Heat Exchanger	\$200,000.00/Year. Higher Than Conventional Due to Large Number of Heliostats Requiring Cleaning, Aligning, and Servicing	\$55,000 Maintenance Generators
Reliability	Limited by Adequate Insolation. High Reliability Due to Modular Components	Limited by Adequate Insolation, Thermal Cycling and Numerous Moving Parts	Limited by Adequate Insolation. Some Problems with Thermal Cycling and Corrosion	Limited by Adequate Insolation Some Problems with Corrosion	Limited by Adequate Insolation Thermal Cycling and Numerous Moving Parts	Limited Speed may be
Manning Necessary	Yes	Yes	No	Yes	Yes	
Storage	Battery Storage	High Temperature Storage of the Heat Transfer Fluid	Battery Storage	None	Thermal Storage	
Other Energy Available	1.2x10 ⁶ Btu Available to Produce Hot Water or Saturated Steam From Recuperator	1.6x10 ⁶ Btu Available to Produce Low Pressure Hot Water	If Cells are Actively Cooled, Some Low Grade Waste Heat is Available	Low-Grade Heat is Available for Hot Water and Space Heating	10x10 ⁶ Btu to Produce Low-Pressure Hot Water	No High Grade Available From
Backup	Large Storage. Other Electric Source For Recharging of Batteries or Direct Use	Large Storage. Other Heat Source. Other Sources of Electricity	Large Storage. Other Electric Source for Recharging of Batteries or Direct Use	Diesel Generators. Other Heat Source	Large Thermal Storage. Other Heat Source. Other Source of Electricity	Large Other Recharge Direct
Development*	\$5,000,000.00 3-to-5 Years of Development	\$5,000,000.00 3-to-4 Years of Development	DOE Goals--\$2.00/W _p by 1982 \$0.50/W _p by 1986 DOE Funded	\$2,000,000.00 3-to-4 Years of Development	DOE Funding Large Units (10 MW _e). Some Work on Small Units (1 MW _e) Being Done in Europe, 10 Years	DOE \$31
Other	Adequate Storage Needed for Extended Periods of Inclement Weather	Adequate Storage Needed for Extended Periods of Inclement Weather	Adequate Storage Needed for Extended Periods of Inclement Weather. Can Supply DC Power Directly	Long Start-Up Time (One Year) Can Be Used to Produce Fresh Water Useful for Space Heating	Adequate Storage needed for Extended Periods of Inclement Weather	Adequate for Calm DC Power

*Based on 1977 Dollars

TABLE 2. COMPARISON OF ALTERNATE ENERGY SYSTEMS

System	Solar Steam Turbine Generator 1 MW _e Power Tower	Wind Energy Conversion System (WECS) 250 kW _e	Geothermal	Gas Turbine Generator (Radioisotope Fuel) 10 kW _e	Diesel Generator 150 kW _e
Elastic Liner on using the Exchangers, erator	A. 165-ft Power Tower with Boiler on Top B. Field of 250 Heliostats C. Building Containing Heat Exchanger, Turbine Generator, and Controls D. Thermal Storage	A. Wind Turbine-Generator B. Tower and Tie-Downs C. Control Unit D. Battery Storage E. Power Conditioning Unit	A. Production Well B. ReInjection Well C. Heat Transfer Coils D. Rotary Vane Expander E. Pumps F. Controls	A. Radioisotope (e.g., Pu ²³⁸ or Co ⁶⁰) Heat Source B. Closed Cycle Gas Turbine Including Turbine, Com- pressor, Recuperator, and Gas Cooler C. Generator D. Controls	A. Diesel Engine B. Generator C. Control System D. Fuel System E. Exhaust System F. Cooling System
One Year ond	1 MW _e	$P = C_p \cdot AV^3$ Where P = Power (KW) ρ = Density of Air A = Turbine Swept Area V = Wind Speed C _p = Power Coefficient	Dependent upon Well Output	Up to 10 kW - Considered Practical ONLY for Low Power Levels due to High Cost. Can Gang 10 kW Units Together for Increased Power Levels	Dependent upon Size of Unit
Insulation red	Adequate Insulation Cooling Water Required	Adequate Wind Speed Required	Adequate Geothermal Potential Required	Isolated from Population due to Radioactive Isotopes	Fuel Deliveries Required
Electrical Thermal Uses	15 Percent	25 Percent	12 Percent	28 Percent	30 Percent
for the Pond s for Pumps range	30 Years	20 Years on Turbine 10 Years on Batteries	10 Years	20 Years	20 Years
10.00	\$5,000,000.00	\$1,000,000.00 with an Average wind Speed of 20 mph and 5 Day Storage	\$5,000,000.00	\$27,000,000.00 for Pu ²³⁸ \$ 5,000,000.00 for Co ⁶⁰	\$35,000.00
Regular Turbine Cleaning and Pumps and	\$200,000.00/Year. Higher Than Conventional Due to Large Number of Heliostats Requiring Cleaning, Aligning, and Servicing	\$55,000.00. Regular Maintenance of Turbine, Generator, and Batteries	Low. Inspect Rotary Vanes Every 6-to-12 Months Replace Rotary Vanes Every 5 Years	\$32,000.00/Year. Refuel Co ⁶⁰ Every 5 Years for \$1,500,000.00. No Need to Refuel Pu ²³⁸ During 20-Year Lifetime	Fuel--\$56,000.00/Year For 5-Day Storage. \$5,700.00/Year for Maintenance
ate with Corrosion	Limited by Adequate Insulation Thermal Cycling and Numerous Moving Parts	Limited by Adequate Wind Speed. High Stress Levels may be a Problem	Limited by Adequate Geothermal Potential. Corrosion a Problem. Cyclic Loading a Problem	Limited by Non-Modular Design	Non-Modular Design and Numerous Moving Parts
	Yes	No	No	No	No
	Thermal Storage	Battery Storage	No Storage Except Lubricating Oils	None	Fuel Storage
is Available and Space	10x10 ⁶ Btuh to Produce Low-Pressure Hot Water	No High Grade Heat is Avail- able from the Power System	Some High Grade Heat is Available	53,000 Btuh for Low Temperature Hot Water Available	1.2x10 ⁶ Btuh to Produce Hot Water from the Engine Jacket or Superheated Steam from the Exhaust
ators. Other	Large Thermal Storage. Other Heat Source. Other Source of Electricity	Large Storage (Batteries). Other Electric Source for Recharging of Batteries or Direct Use	If Geothermal Potential is Adequate, None Required	Diesel Generators	Fuel Storage. Other Generators
Development	DOE Funding Large Units (10 MW _e). Some Work on Small Units (1 MW _e) Being Done in Europe, 10 Years	DOE Funded; \$31.7 x 10 ⁶ in 1978	\$3,500,000.00 2-to-3 Years of Development	\$30,000,000.00 3 Years	Available
ime (One Year) Produce Fresh Heating	Aduquate Storage needed for Extended Periods of Inclement Weather	Adequate Storage Needed for Extended Period of Calm Winds. Can Supply DC Power Directly	Risk in Finding a Site with Good Potential is High	Additional Shielding Required on Co ⁶⁰ Fuel Source Heat Generated Continuously Whether or not Electricity is Produced	Proven Systems Employed in Remote Sites now

2

TABLE 3. NUMBER OF SITES WITH FAIR TO GOOD ALTERNATE ENERGY POTENTIAL

POTENTIALS	CATEGORIES							TOTAL
	I	II	III	IV	V	VI	VI	
Good Solar	--	--	1	1	4	--	2	8
Fair Solar Year Around Summer Only	--	--	1	5	7	--	3	16
Good Wind	--	14	8	--	--	5	--	27
Fair Wind	--	--	1	2	5	4	4	16
Good Geothermal	--	18	11	2	2	4	--	37
Fair Geothermal	--	--	2	1	--	--	1	4
	--	--	--	1	--	--	--	1

Note: Dashes indicate not applicable

SECTION III
ENERGY STORAGE SYSTEMS

INTRODUCTION

There will be times when an alternate energy system produces more energy than is consumed, and it may be desirable to store this energy for later consumption. There are several ways by which energy can be stored. These storage modes include:

Battery	Compressed Air
Thermal Storage	Magnetic
Thermochemical	Capacitors
Flywheels	

An energy storage device was mentioned in Section II as part of the systems except for the radioisotope-fueled, geothermal, and solar pond systems. The storage methods mentioned in Section II represent state-of-the-art designs in conjunction with the systems. Presently available storage devices are not the only possibilities. Many new storage devices are being researched which offer lower cost, larger capacity, less maintenance, and higher efficiency and reliability. Some of these systems will be discussed in this section.

Energy storage offers certain benefits to users of an alternate energy system. When an energy system relies on weather patterns for operation, storage or back-up generation capacity is required. If a back-up system is available, energy storage is not as important. However, most alternate energy systems benefit from some storage even if back-up is used. The storage permits continuous operation in the event of fluctuations in the alternate energy source (e.g., variable winds, shadowing of solar collectors, etc.), and an increase in overall system efficiencies. There is, however, an economic trade-off (i.e., storage efficiency versus cost) which must be considered. In the case of USAF remote sites, the use of diesel generators for back-up offers distinct advantages (e.g., the diesel generators are already there). While the goal in implementing an alternate energy system is to

divorce the system from fossil fuels (they will always be needed for lubrication), this is not always possible, especially when a newly-developed concept is used. This, plus the fact that energy storage is expensive, lends credibility to using the existing energy-producing systems as a back-up. A site-specific analysis will be required to determine the extent and capacity to be carried by a storage system.

SYSTEMS

Batteries--A battery is an electrochemical energy storage device which uses electricity for charging and returns DC electricity when discharging. Lead-acid batteries are similar to automotive batteries. Advanced batteries fall into three basic categories: (1) aqueous batteries with an electrode surrounded by a liquid electrolyte (similar to lead-acid systems); (2) non-aqueous, high temperature batteries which use a nonaqueous material to conduct ions; and (3) reduction/oxidation (redox) batteries which reduce aqueous solutions to store energy.

Lead-acid batteries--A lead-acid battery storage system consists of an array of battery cell modules and an inverter unit to produce AC electricity. These modules may be grouped to supply any power level for any length of time, although cost and practical size limitations would dictate an optimum storage size. Eight hours of storage for a 250 kW (2 MWh) system would cost \$150,000 (1977 dollars), but this cost is expected to drop to \$90,000 by 1985. The cells should last 10 years if they are not discharged too deeply (20 years by 1985) and be 65 percent efficient now (75 percent by 1985). For a 250-kW system, the O&M costs would be \$2,000 per year (1977 dollars). No personnel would be required on a continuous bases although routine inspection is necessary.

A lead-acid battery storage system would be fairly reliable, there being only minor problems with corrosive attack and high-temperature operation. A major disadvantage of lead-acid batteries, however, is their high weight-to-storage-capacity ratio. A commercial lead-acid system weighs about 100 lb, 60 to 80 lb of which is lead. Another problem is the fact that lead-acid

batteries produce highly flammable hydrogen gas, arsine (AsH_3) gas, and stibine (SbH_3) gas, the latter two being toxic. If the batteries are stored in a well-ventilated structure, these drawbacks are not major but must be considered.

Advanced batteries--The three basic categories of advanced batteries will be discussed here. These batteries are in the developmental stages at this time. Table 4 shows certain of the characteristics, developers, and projected demonstration dates of these cells.

Aqueous--An aqueous (water-based) battery consists of an electrode surrounded by a liquid electrolyte similar to a lead-acid cell.

One type of aqueous cell is a zinc-chloride battery being developed by Gulf-Western Industries and Occidental Petroleum Corporation. Units to 50 kWh have been tested at Argonne National Laboratories, and 10-Mwh units are expected to be tested by 1980. Zinc-chloride batteries cost about \$2,000*/kWh now although this cost should drop to \$40 to \$50 per kWh in the future and be comparable to lead-acid cells today. This cost is higher than a lithium or sodium battery, but the zinc-chloride battery produces voltage at a constant level, thus making the inversion to AC less expensive.

Zinc-chloride cells can operate at constant temperature but require complex plumbing to circulate the electrolyte. Chlorine gas may also be a problem.

Another aqueous battery is the zinc-bromide cell. Early work was carried out by the G.E.L. Corporation, Raleigh, NC; and the General Electric Corporation has operated a device for 2,000 cycles at two and one-half hour discharges. Efficiencies of 65 to 80 percent are thought possible for a future cost of \$17 to \$26/kW, excluding the cost of pumps, controls, and marketing. The major problem is the development of a reliable membrane which does not allow the unit to discharge itself. Also, the bromine solution is caustic and must be contained properly.

* These and the following cost estimates are in 1977 dollars

TABLE 4. LOAD-LEVELING BATTERIES: CANDIDATES AND CHARACTERISTICS; DEVELOPERS AND DEMONSTRATION DATES

	Operating temperature (C°)	Theoretical cell energy density (Wh/lb)	Design cell energy density (Wh/lb)	Design volumetric energy density (Wh/lb ³)	Depth of discharge percent	Density 10 hr rate (mA/cm ²)	Active Materials cost (\$/kWh)	Demonstrated cell size (kWh)	Demonstrated cell life (cycles)	Critical materials	Major developers	BEST ^e facility test (5-10 MWh)	Demonstration station	Commercial introduction
Lead-acid (Pb/PbO ₂)	20-30	110	11	0.75	25	10-15	8.50	>20	>2000	Lead	Gould Inc.; ESB, Inc; C&O Batteries; Globe-Union, Inc.; K-W Battery Co.	1979	1981-83	
Sodium sulfur (Na/S)	300-350	360	70	2.5	85	75	0.49	0.5	400	None	General Electric Co.; Dow Chemical Co.; Ford Motor Co.	1981-82		
Sodium-antimony trichloride (Na/SbCl ₃)	200	350	50	2.0	80-90	25	2.35	0.02	175	Antimony	ESB, Inc.	1981-82		
Lithium-metal sulfide (LiS/FeS ₂)	400-450	430	85	3.5	80	30	4.27	1.0	1000	Lithium	Atomics International Div.; Rockwell International Corp.; Argonne National Laboratory	1980		
Zinc-chlorine (Zn/Cl ₂)	50	210	45	1.0	100	40-50 ^b	Theor-0.59 ^c Prac-0.84	1.7	100	Ruthenium (catalyst)	Energy Development Associates	1980		
Zinc-bromine (Zn/Br ₂)	30-60	195	40	1.5	90	30	Theor-1.56 Prac-1.65	0.01	2000	None	Exxon; Gould; GE	1983	--	Post 1985
Hydrogen-chlorine (H ₂ /Cl ₂)	30-60	450	50	0.3	95	300	0.20	0.001	50	Platinum Ruthenium (catalyst)	GE; BNL	1983	--	Post 1985
REDOX	ambient	--	40 ^d	--	90	40-60	\$3-\$10	0.005	200	None	NASA-Lewis	1984	1986	1988
Iron REDOX	ambient	--	38	2.6			\$1	-1	>1000	None	G.E.L.	--	1980	--

^aAlso known as utilization of active materials

^b5 hr rate

^cGE calculates for (Zn/Cl₂)

^d(Wh/litre of solution)

^eBEST = Battery Energy

SOURCES: EPRI Journal and Kurt W. Klunder, Battery Branch, Office of Conservation, ERDA.

Nonaqueous, high-temperature batteries--This type of cell employs a non-aqueous material to conduct the ions and is operated at high temperatures [i.e., greater than 572° F (300° C)]. The sodium-sulfur cell is such a non-aqueous cell that is being developed by the Ford Motor Company. Ford Motor Company has run 10 to 15 W cells in excess of 3,000 cycles and hopes to operate a 5 to 10 MWh battery in 1981. Dow Chemical is also studying the sodium-sulfur cell. At present, the cost is \$3,000/kWh, but Ford Motor Company predicts costs of \$30/kWh in 1985-87, while Dow Chemical predicts costs of \$24.50/kWh by 1986-88. Systems have been demonstrated at 90-percent discharge with an overall efficiency of 77 percent. The main developmental problem is the creation of a reliable beta-alumina electrolyte.

Another nonaqueous battery is the lithium-metal sulfide cell. Argonne National Laboratories is developing this cell under a DOE contract. At present, 150-W cells have been run 500 cycles. By 1982, a 5 to 10-MWh system should be tested; and costs are projected to be \$29/kWh by 1985-87.

Both of these nonaqueous batteries operate above 572° F (300° C). The battery seals also present problems. Further, both lithium and sodium are flammable (explosive in certain environments), and adequate protection is required.

Redox batteries--The cost of a redox battery could be as low as \$10/kWh or less because the energy is stored in tanks of inexpensive chemicals. The major problem has been the development of a semipermeable membrane. Demonstration for utility applications is expected by NASA-Lewis by 1985.

Iron redox--G.E.L. Corporation is studying an iron redox battery. The basic principle is the same as in the redox battery except that the same chemical is used at both electrodes. The membrane required is much simpler. An iron redox battery is shown in Figure 16. Systems have survived 1,000 cycles with an overall efficiency of 65 to 75 percent. Efficiencies to 85 percent are possible with moderate discharge rates. There is no damage from deep discharges.

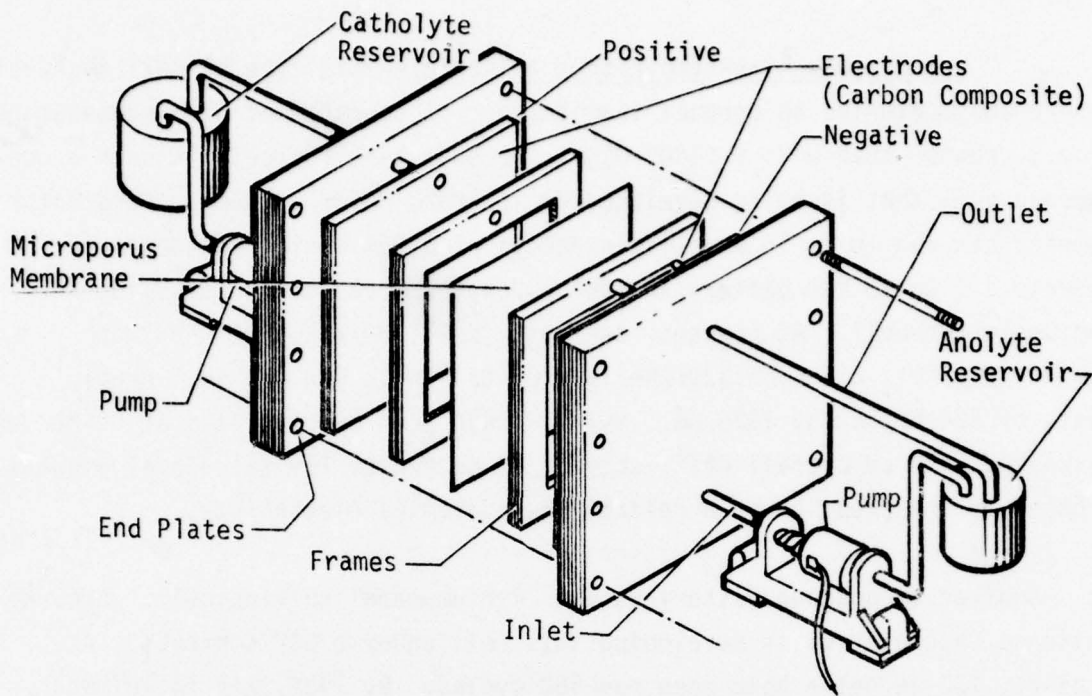

Figure 16. Iron Redox Battery Structure and Plumbing Diagram

The iron redox battery is ideally suited to solar energy applications for storing large amounts of energy for 10 to 20 days. A 2.2-MWh system is being developed for the Mississippi County Community College by G.E.L. Corporation. This storage unit requires 15,000 to 20,000 gallons (60,000 to 80,000 litres) of electrolyte, and this DOE-sponsored project is expected to be completed in late 1979.

The cost of a battery storage facility is a function of three factors: battery, power conditioning costs, and facilities costs. Power conditioners serve four functions: (1) regulation of battery charge and discharge rate, (2) action as a switching system to permit the load to draw from the batteries when required, (3) rectification and filtering AC power in order that the batteries may be charged from on-site generators, and (4) inverting the DC power from the batteries to AC for use by the loads. The present cost of power conditioning equipment is about \$200 to \$500/kW for a rated power of 100 to 250 kW. The expected long-term costs should be \$60 to \$90/kW. Whichever battery

system is employed, an inverter is required; and its cost must be considered in calculating the total storage costs.

Battery storage is ideally suited to solar photovoltaics and WECS because these are not heat engines. Solar systems which produce heat to run a turbine generator might better benefit from thermal storage.

Thermal storage--Thermal storage is the storage of heat generated by an alternate energy system which is not used in the production of electricity. There are three basic thermal storage techniques: (1) sensible heat storage, (2) latent heat storage, and (3) use of heat to produce a chemical reaction which, when reversed, releases heat.

Sensible heat--Sensible heat refers to the energy stored in a body by virtue of a rise in its temperature. Water can be used to store heat to 300° F (149° C) if a pressurized vessel is used. An insulated tank would be required to prevent losses. Energy storage in rocks is also possible, although a much larger volume would be required because the rocks have a lower heat capacity than water.

In order to store energy at higher temperatures, different materials would be required. Refractory brick has been used in Great Britain and West Germany to store energy at temperatures of up to 600° C (1112° F). Another possibility is to pass helium through a solar collector and then through a pressure vessel lined with refractory brick, heating them to 527° C (980° F). Cost estimates for such a system run \$11 to \$14/kWhth. An even simpler possibility is to pipe superheated steam through pipes embedded in steel. Here no pressure vessel is required; there are no moving parts; and little development would be required.

Sensible heat may also be stored in a heat-transfer oil. Sandia Laboratories uses this method for the storage in its solar organic vapor turbine generator (see Section II). There are some problems with this method in that the heat transfer oil degrades with time and must be filtered off and replaced. Even when these systems are used, a large volume of material is required for storage.

Latent heat--When a substance changes phase (melts, boils), it absorbs a large amount of energy at a constant temperature, thus permitting the use of much smaller volumes than required for sensible heat storage. Also, the phase-change occurs at a constant temperature beneficial in driving a heat engine. For low temperature [77° - 88° C (170° F - 190° F)] storage, several organic and inorganic compounds have been developed. Some of the identified problems include the need for more complex heat exchangers. Nucleating devices may be necessary to assure uniform solidification, and corrosion must be prevented.

One method of storing energy at high temperatures is being investigated by the Jet Propulsion Laboratory. A bundle of tubes is embedded in a cylinder 60 ft (18 m) long and 12 ft (3.7 m) in diameter filled with sodium hydroxide (NaOH). Steam is pumped through the pipes where the heat is transferred to the NaOH. It is estimated that such a system could store 52 MWhth at 400° F (204° C) to 650° F (343° C) for \$13/kWhth. Sodium hydroxide is highly corrosive and thus requires expensive containment to prevent leaks. This would be an ideal storage medium for use with a Rankine cycle system. Other high-temperature latent heat compounds are also being investigated.

Thermochemical reactions--Thermochemical reactions take advantage of the principle that heat can cause a chemical reaction which, when reversed, releases energy as heat. There is good potential in this storage method because the reaction products may be stored simply or moved. More developmental work is required in understanding the basic chemical reactions. At present, fairly sophisticated reaction apparatus is required.

Flywheels--Flywheels can be used to store energy as kinetic energy in the spinning flywheel. A flywheel storage device would consist of ganged flywheels on a horizontal shaft with bearings, a vacuum system to reduce air resistance, and appropriate support and control subsystems. The system can be sized to fit any noncontinuous demand. A 250-kW system for 8-h storage would cost \$3,500,000 (1977 dollars) at present. This cost should drop to \$650,000 (1977 dollars) by 1990 due to developmental work in using advanced composites for the flywheels and development of better bearings. Such a system should last 20 to 25 years with an overall efficiency of 70 percent.

High stress levels are a problem area as well as numerous moving parts and the non-modularity of the design. The O&M costs would be \$4,000/yr (1977 dollars) for a 250 kW system. The maintenance would consist of changing the bearings and overhauling the clutch and gear box. Flywheels have been mainly developed for use in transportation, and much developmental work is required for using flywheels to store electricity.

Hydrogen--One interesting approach to storage would be the generation of hydrogen (H_2) gas for either direct burning or use in a fuel cell. Water can be broken down into hydrogen and oxygen by electrolysis of water, a multistage process, or solar-direct. The hydrogen can be burned in oxygen, thereby releasing energy as heat to drive a turbine generator or to be used in a fuel cell to generate DC electricity.

The electrolysis of water can be accomplished by the use of excess electrical power from on-site generator ability; the production rate, however, is low. Several multistage processes for generating hydrogen have been studied. Most are cumbersome for on-site application, but the use of lower temperatures is possible, and the gases are released separately. The efficiency of the multistage processes is low, but work toward its development is continuing. The other possibility for hydrogen generation is the use of a photocatalytic electrode such as GaAs. The light striking the electrode directly converts water into hydrogen and oxygen. Also, H_2 is released when light strikes a complex rhodium compound, and a ruthenium compound can split water when a monolayer is applied to glass and exposed to the sun. These techniques exhibit low efficiencies, and long-term stability has not been demonstrated. No cost analyses have been conducted, as research is just beginning. The future potential for hydrogen generation, however, has been demonstrated.

When hydrogen and oxygen are combined in a fuel cell, DC electricity is produced. A system to generate 250 kW would cost \$60,000 (1977 dollars), last 20 years at an efficiency of 35 percent. The O&M costs would be \$3,500/yr (1977 dollars). Hydrogen-rich fuel could also be used to operate the fuel cell if hydrogen production were insufficient. This fuel would be naphtha and would cost \$60,000/yr (1977 dollars) if used exclusively. Much developmental work is required over the next five years for such a system, but the potential for using a fuel cell as backup is promising.

Others--The storage methods discussed above convert electricity into chemical energy or store thermal energy for later conversion to electricity. One potential for storing electricity directly is to use a loop of superconducting wire. Although this method is being researched, it is doubtful that it will play a significant role for some time.

Another storage possibility is to use compressed air to drive a turbine generator. Tremendous pressures are required to store energy in this form unless a huge volume is available. This compressed air could be stored in underground caverns at lower pressures, but this application for a remote site application appears inappropriate. One company, Omnium-G of Anaheim, California, sold a compressed air storage system device (the system is no longer sold due to its high cost). The system used solar generated electricity to compress air to 34.5 MPa (5000 lb/in²). One module could store 60 kWhr, and the cost was \$25,000 (\$417 per kWhr). The compressed air storage device may be sold again if the cost can be cut in half.

Energy can also be stored in capacitors or magnetically, but these methods are under investigation and appear inappropriate for remote sites.

SUMMARY

It is difficult to compare the various energy storage techniques directly due to the differing forms in which energy is stored. Certain alternate energy systems lend themselves to certain energy storage systems. The choice of a specific storage system will be based on a detailed analysis of power requirements, percentage of power supplied by the alternate energy system, expected periods of nonavailability of alternate energy sources, back-up potential, location constraints, monetary constraints, and mission of the site.

The use of storage to supply all of a site's power will necessitate the use of a larger alternate energy system than if back-up is employed. This will mean increased cost and complexity, and it may be found that the less expensive route is to use the existing diesel generators for back-up.

SECTION IV SURVIVABILITY ANALYSIS

INTRODUCTION

The degree of survivability of each alternate energy system was determined against nuclear and conventional weapons, sabotage, vandalism, civil disturbances, and natural disasters. *Degree of survivability* in this report will be defined as the relative probability of a particular system's retaining its operational capability as compared to other energy systems. Specific estimates of damage and reductions in operation of each system will be presented. It should be emphasized that this information is based on specific weapons effects data. However, engineering judgment was exercised in applying the information to the alternate energy systems. As most of the systems are still in the development stage, assumptions which are open for additional consideration were made concerning typical installations and structural designs. These assumptions have a direct effect on the survivability analysis performed on the systems, and a different analysis can be performed by means of other design and construction criteria. The assumptions made for these systems, however, are reasonable and represent typical systems for conventional installations presently in use. The hardened systems are the standard systems which have been modified to improve their survivability against various threats and disasters. It is not intended to recommend engineering designs for the standard or the hardened systems but to present conceptual designs and modifications developed from engineering judgment.

APPROACH

The approach taken to analyze each energy system for survivability was to assume a design. Due to the variability of the systems, some are more appropriate for large energy production and others are more appropriate for low production levels. For example, the power tower (solar steam turbine generator) is typically designed for power requirements in excess of 1 MW, whereas the radioisotope-fueled gas turbine generator is more appropriate in

the 10-kW range. Therefore, the assumption was made that each system designed for the most appropriate energy production level should be analyzed. Next, a standard conceptual design was developed, and its survivability limits were determined. *Survivability limits* are defined to be the maximum nuclear overpressure without major failure, probability of a direct hit from conventional weapons, percentage of damaged equipment from conventional bomb fragments at a particular range, damage from sabotage, vandalism, civil disturbances, and natural disaster limits (i.e., maximum wind velocity and earthquake forces). All of this information was not determined for all the systems. The weakest component of each system was selected for the design analysis. For example, the solar systems were studied with respect to maximum overpressures under which glass plates and windows remain intact. The VAWT was analyzed with respect to maximum wind forces and velocities. This is not to say that the other categories of threats were not studied. They would require additional engineering judgment to determine their survivability limits for the systems. Assumptions were then made as to the design of the hardened system and the effects of its design on its survivability. All of these were included in the development of the system evaluation charts and final decision matrix presented in Section V.

The nuclear threat was established as a 1-kT nuclear device. This weapon was selected because it was a reasonably sized weapon which might be used in a tactical nuclear offensive against remote USAF sites. The principal effects from a nuclear device that are pertinent to this study are overpressure from airblast and ground shock. Nuclear survivability limits for each system will be determined based on maximum allowable airblast overpressure or ground shock for system operation. A 1-kT nuclear overpressure curve is shown in Figure 17. Other nuclear effects include cratering and ejecta, electromagnetic pulse (EMP), and nuclear and thermal radiation. Cratering ejecta were eliminated from this analysis because at the ranges at which these effects are exerted, the air blast overpressure is the controlling factor. A high surge of electric current is produced in circuits due to the generation of EMP and is inversely proportional to the length of cable exposed to the EMP signal. Its effects on the alternate energy system were not studied because the circuit designs can be varied to minimize its effects. Similarly, radiation effects were not considered due to uncertainty in designs.

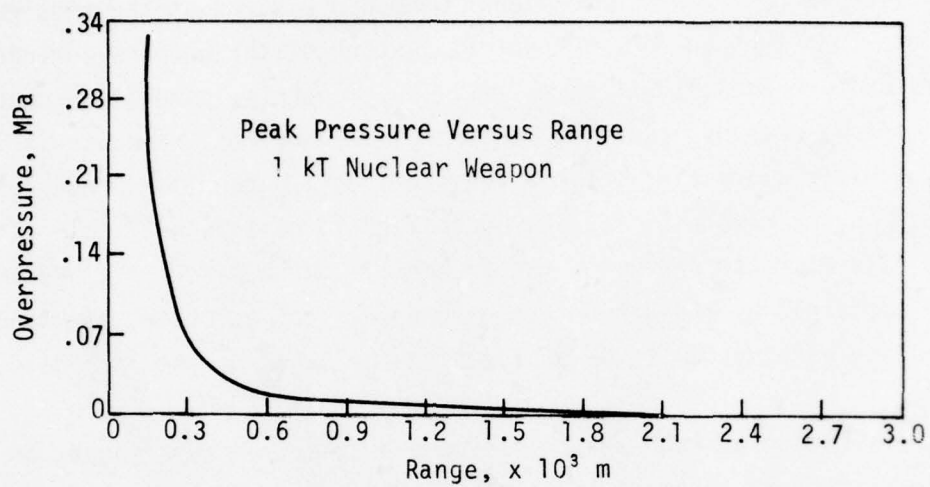

Figure 17. One-kiloton Nuclear Overpressure Versus Range

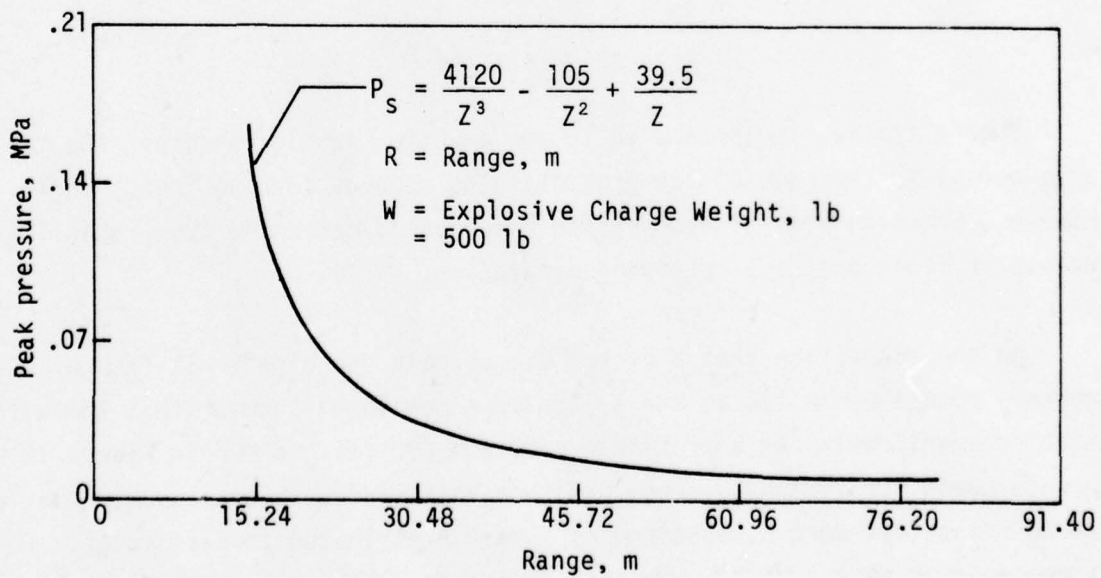

Figure 18. One Thousand Pound Conventional Bomb Overpressure Versus Range

Conventional weapons include a wide range of weapons varying in size, range, and accuracy. The primary effects of these weapons are airblast overpressure and fragmentation, with the exception of fire and incendiary devices. An overpressure versus range curve is shown in Figure 18 for comparison with the nuclear weapon. The conventional weapon pressures at the same range are much less than the nuclear. A general listing of the weapons includes bombs, mortars and grenades, small arms, artillery, rockets, demolition charges and shaped-charge weapons, and fire and incendiary devices. Because it is difficult to obtain classified information pertinent to the most probable types of threats for the remote sites, it was decided to utilize available information in the literature to determine the probability of a direct hit and to estimate damage sustained by the direct hit of one round of a mortar-type weapon. This would allow each system to be analyzed on the basis of the same data.

The accuracy of each weapon can be characterized by a parameter known as the circular error probable (CEP). The CEP is the radius of a circle around the intended target in which 50 percent of the fired rounds will land. For example, a 102-mm mortar has a CEP of 36.6 m (120 ft). This means that 50 percent of the rounds fired will land less than 36.6 m (120 ft) from the target. For comparison purposes, a CEP equal to 61 m (200 ft) was selected. The equation relating the probability, CEP, and exposed area of the target is

$$P_h = 1 - \exp\left(\frac{-0.22 \text{ AREA}}{\text{CEP}^2}\right). \quad (1)$$

Theoretically, the area used in the equation should represent the target area normal to the path of the projectile to account for the impact angle. However, the plan area of each system was used to determine the probability values in Table 5 as a simplifying assumption.

On the assumption that a system did sustain one direct hit from a 102-mm mortar, damage estimates to the system were developed knowing that the effective fragment radius is approximately 21.3 m (70 ft). Shown in Figure 19 are damage areas for various weapons. Within this radius it was assumed that all solar reflectors were damaged and no longer contributed to the system. For other systems (e.g., VAWT), specific damage to individual units was estimated.

TABLE 5. PROBABILITY OF DIRECT HIT, PERCENTAGE

System		Circular Error Probable (CEP), ft (m)				
		50 (15.2 m)	100 (30.48 m)	200 (60.96 m)	500 (152.4 m)	1000 (304.8 m)
1 Solar Gas-Turbine Generator	Collector Array	97.70	61.20	21.10	03.70	00.94
	Control Building	08.40	02.20	00.55	<00.10	<00.10
2 Solar Organic Vapor Turbine Generator	Collector Array	100.00	98.90	67.40	16.40	04.40
	Control Building	03.50	00.88	00.22	<00.10	<00.10
3 Solar Photovoltaics	Collector Array	100.00	93.60	49.70	10.40	02.70
	Control Building	03.50	00.88	00.22	<00.10	<00.10
4 Solar Pond	Pond	100.00	100.00	99.30	54.40	17.80
	Control Building	03.50	00.88	00.22	<00.10	<00.10
5 Solar Steam Turbine Generator	Tower	01.50	00.39	00.10	<00.10	<00.10
	Collector Array	100.00	100.00	100.00	99.90	81.00
6 Radioisotope-Fueled Gas Turbine Generator		00.60	00.15	<00.10	<00.10	<00.10
7 Wind Energy Conversion System		49.90	15.90	04.20	00.69	00.17
		19.60	05.40	01.40	00.22	<00.10
8 Geothermal						

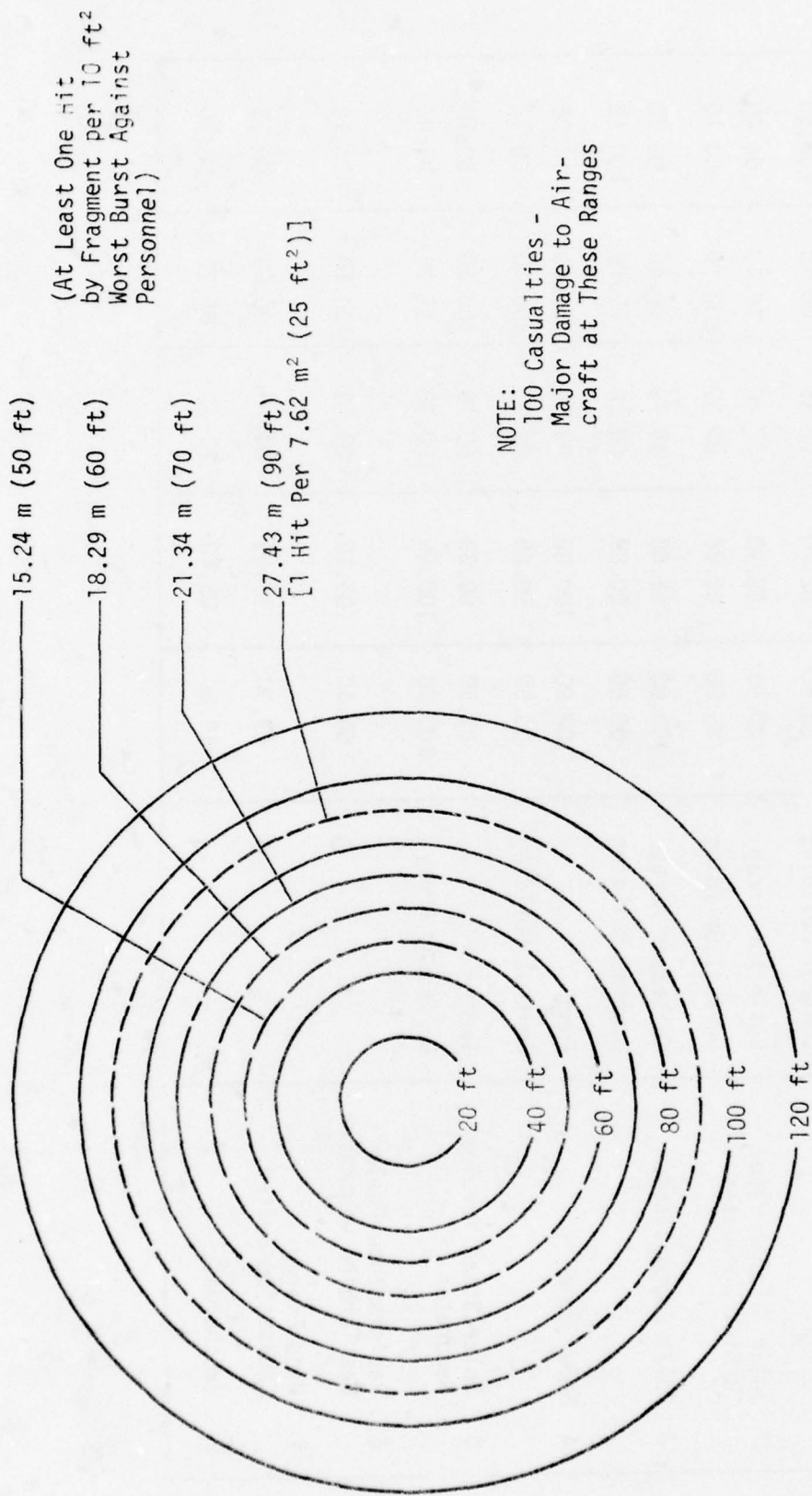

NOTE:
100 Casualties -
Major Damage to Air-
craft at These Ranges

Approximate Areas of Damage by Various Surface-to-Surface Weapons
and Their Fragments (from Nonnuclear Weapons Effects on Protective
Structures, by W. Baker)

Figure 19. Areas of Damage for Various Weapons

The assumption of one mortar round being fired during a conventional weapons offensive is not realistic, as mortars can be fired at the rate of 15 to 20 rounds per minute. Assuming an attack lasted one minute, the amount of damage can be multiplied by 20 (20 rounds fired) to determine the total damage. These estimates also include damage resulting from the weapon air-blast, but in most cases these estimates are controlled by the fragmentation effects.

Sabotage typically involves an agent who knows the location of, and has access to, the target. Damage is usually a result of demolition charges strategically placed on critical sections of the target. The viewpoint was taken that defensive measures would have little effect on resisting sabotage. The most significant factor in the sabotage analysis was the accessibility of the target (in this case the alternate energy systems) to personnel. The system evaluation charts in Section IV indicate that most of the systems are rated very low in the sabotage category. This low rating is due mostly to the open nature of the systems and to lack of methods to improve the security of the system. No specific survivability limits were determined.

Vandalism and civil disturbances are other categories difficult to quantify due to the fact that the design of individual components of the system plays a large role. As with sabotage, the accessibility of the system to vandals and political terrorists is controlled by the level of security at the particular site. Again, specific estimates of the survivability limits were not determined. The survivability against vandalism and civil disturbances is indicated on the system included in the design matrix.

Natural disasters include earthquakes, wind and snow storms, hurricanes and tornadoes, floods, and lightning. Analyses were performed to evaluate the system susceptibility to earthquakes and maximum wind force where possible. Effects of floods and lightning were eliminated from the study because information concerning the designs of the systems is not sufficiently specific to allow detailed analyses. Hurricanes and tornados were grouped into the general area of wind forces. Therefore, earthquakes and wind forces were the only natural disasters considered.

SURVIVABILITY AND SYSTEM HARDENING METHODS

(1) Solar gas turbine generator--The solar gas turbine generator (Figure 1) consists of a parabolic dish solar collector 7.3 m (24 ft) in diameter that has a reflective surface which concentrates the sun's rays onto a receiver. Each unit would produce approximately 20 kW, and 13 units are required for 250 kW. The dish has dual-axis tracking provided by the U-shaped supporting mechanism. The actual surface of the dish may be composed of 0.3- to 0.45-m (1- to 1-1/2-ft) square glass mirrors that are individually replaceable or may be constructed from a highly polished metal surfacing. The size of the structural members was assumed to be sufficient to support the dish and to resist low velocity winds of approximately 13.4 m/s (30 mi/h).

Based on the 1-kT standard, this unit would survive at a range greater than 914.4 m (3,000 ft), approximately 6.89×10^{-3} to 13.79×10^{-3} MPa (1 to 2 lb/in²). This is due primarily to the critical pressures for breaking the glass mirrors. If the system were made of a highly reflective metal surfacing, the range would be less, indicating a higher pressure level. Against conventional weapons, the system is susceptible both to airblast and fragmentation effects, but survivability is strongly controlled by fragmentation. Shown in Table 5 is the probability of a direct hit on the system for various CEP. As stated earlier, the damage estimates were developed using one mortar round. Mortars typically have CEPs in the 30.48-m to 60.96-m (100 to 200 ft) range. A CEP of 60.96 m (200 ft) was selected as the basis for comparison. Assuming the spacing between units to be 17.4 m (57 ft), 4.6 units would be damaged by one mortar round resulting in approximately 3.6 percent damage.

In the area of sabotage, an explosive charge properly placed at the base or pivot points would completely eliminate the unit. Vandalism would produce a small amount of damage which could easily be repaired. Similarly, civil disturbances would produce a small amount of damage.

It is estimated that the earthquake survivability is very good, and the unit will resist 40.23 to 44.70 m/s (90 to 100 mi/h) winds.

Methods to harden the system include increasing the size and strength of the structural supporting members, constructing the reflector of a ballistically resistant material or of a material that would allow the fragments to pass through, thus minimizing the damage to the reflector area. Of course, the control systems can be placed underground to prevent damage to the motors and turbine generator. Detailed analyses of the unit may indicate that certain components are more valuable than others, and a design could be developed in order to protect these components by allowing the system to fail before the components are damaged.

(2) Solar organic vapor turbine generator--The solar organic vapor turbine generator (Figure 3) is composed of parabolic trough solar collectors that concentrate the energy on a pipeline that runs the length of the collector. A fluid contained in the pipe is heated and flows to energy conversion units (Section II). The trough collectors were assumed to be single axis tracking but could be dual axis and constructed by conventional design procedures and materials. The reflector section can be constructed from mirror sections (as with the solar gas turbine generator), highly reflective metal, or laminating a reflecting material to a parabolic trough form. The collector array was assumed to be concentrated in one area with a collector spacing of 5.03 m (16.5 ft) [3 times the collector diameter of 1.68 m (5.5 ft)].

With respect to nuclear survivability, the range is 914.40 m (3,000 ft) equal to the solar gas turbine generator and is dependent on the type of construction of the parabolic reflector. Damage from airblast may cause misalignment of the piping system. Conventional weapons will produce both fragmentation and airblast damage. Fragmentation effects from one mortar round will produce approximately 2 percent reflector reduction. Airblast damage will be contained within the area of fragmentation effects.

Methods of hardening the system include upgrading the structural members, varying the reflector construction as previously mentioned in the other systems, using ballistically-resistant plastic tubing similar to Lexan[®], designing

joint couplings to fail at selected pressure levels to minimize damage and repair time, and locating the control systems underground. It has been shown that wind forces can be significantly reduced if a perimeter fencing similar to snow fence is located around each collector array. The probability of a direct hit can be greatly decreased if the collector array is divided into smaller arrays located around central control systems. For example, a single array covering 18,952.2 m² (204,000 ft²) would have a probability of a direct hit of 67.4 percent [CEP = 60.96 m (200 ft)]. Dividing the array into four sections of 4,738.1 m² (51,000 ft²) each would reduce the probability of a direct hit to 24.5 percent [CEP = 60.96 m (200 ft)].

Sabotage, vandalism and civil disturbances are interrelated. Again, an explosive charge properly placed at the pivot points or base of the collector would terminate operation of the unit. Depending on the construction of the collector, vandalism would produce little damage.

The effect of strong ground motions on piping systems makes this system more susceptible to earthquakes than the solar gas turbine generator. However, the piping system was assumed to be fairly flexible which would allow the system to survive. The system possesses a low structural profile combined with adequate dynamic foundation design which increases its earthquake survivability. If the trough collectors are stowed in the "concave down" position, the resistance to wind forces is significantly increased. It is estimated that the collectors could survive a 40.23 to 44.70 m/s (90 to 100 mi/h) wind without damage.

(3) Solar photovoltaic systems--Solar photovoltaic systems (Figure 5) convert the sun's energy directly to electrical power. The photovoltaic cells must be cooled to increase efficiency which requires a piping system. Construction of the system was assumed to be conventional in nature and sufficient to resist typical wind forces [13.41 m/s (30 mi/h)].

On the basis of this information, it is assumed the survivability against a nuclear threat would be slightly improved over the preceding systems. This

assumption is based primarily on the increased resistance of the glass materials used in the photovoltaic system. It is estimated that the arrays and control building will withstand 0.012 to 0.028 MPa (3 to 4 lb/in²) at a 4921.26 m (1,500 ft) range. However, the susceptibility to damage from fragments produced by conventional weapons is increased. In photovoltaic systems, damage to one cell causes the efficiency of the system to be significantly reduced if proper circuitry safeguards are not incorporated in the system design. This fact might require the damaged unit to be completely removed from the circuit so that the energy produced by other units would not be drained by the damaged cell. Estimated damage produced by one mortar round would result in a 12 percent reduction in photocell operation. This reduction may be larger if the proper safeguards are not included in the design.

Survivability from sabotage, vandalism, and civil disturbances are approximately the same as for preceding systems; and damage estimates are small for vandalism and civil disturbances. Susceptibility to vandalism is decreased slightly since the target area is small. The individual units are resistant to earthquake forces because the cell arrays are sectioned. It is estimated that a conventional design should survive 40.23 to 44.70 m/s (90 to 100 mi/h) winds.

Methods of hardening the system include locating the control systems underground, providing a perimeter fence to reduce wind loads, constructing the photovoltaic cells on a concrete or steel frame support system, using a high tensile strength plastic to increase the allowable membrane stresses induced in the cell lenses, and dividing the array into smaller arrays to decrease the probability of a direct hit.

(4) Solar pond--The solar pond system consists of a large salt water reservoir in which the water becomes stratified due to various salt contents. Heat energy is trapped in the lower layers which can then be tapped for heat-energy conversion. The pond was assumed to be approximately 304.8 m (1,000 ft) diameter (250 kW of energy produced) and a control building of 92.90 m² (1,000 ft²).

It is estimated that a 0.61 m (2-ft) surface wave would cause the water stratification to be disturbed to significantly affect the efficiency. This equates to 0.13 MPa (19 lb/in²) overpressure from a 1-kT nuclear weapon at a range of 182.88 m (600 ft). The control building is estimated to survive approximately 0.03 MPa (4 lb/in²) at a range of 457.20 m (1,500 ft). Damage from conventional weapons would be more severe because the weapons would be detonated in the pond rather than at some range removed from the pond. Also the fact that the pond requires a larger amount of time to reach equilibrium with respect to stratification of the salt water layers would mean that a slight disturbance would further inhibit stratification. The probability of a direct hit from a mortar round is very high since the pond requires a large area. This same fact causes the system to be highly susceptible to sabotage, vandalism, and civil disturbances. Damage from a small explosive charge would cause the pond stratification to be disturbed, but small objects (e.g., stones) are believed to have little effect on the system operation. However, the survivability from earthquakes and wind forces is greater than in previous systems.

Very few methods exist that enable the solar pond system to be hardened. The control building can be located underground to increase its survivability. The required pond area can be divided into several smaller ponds with a central control system, but this increases the maintenance and decreases the reliability of the system due to the concentrated brine solution and corrosion problems. It has been suggested to construct a protective dome of transparent material above the pond. This has the disadvantage of a reduction in efficiency due to water condensing on the inside of the dome and absorbing the solar energy. A protective screen could be placed over the pond, but very few materials exist that are transparent enough to allow solar radiation to pass through and still have sufficient strength to be ballistically resistant.

(5) Solar steam turbine generator--The solar steam turbine generator (Figure 9) is composed of an array of dual-axis tracking reflectors that reflect and concentrate the sun's energy on a boiler mounted on a tower approximately 50.29 m (165 ft) high. The boiler contains water that is heated

and converted into electrical power by means of turbine generators. The smallest system (1 MW) requires an array of 7,000.24 m² (75,350 ft²) of mirror surface area covering approximately 17,419.32 m² (187,500 ft²) of land area. A control building of 9.29 m² (100 ft²) was assumed for the system. Assumptions were made pertaining to the structural configuration of the mirror units.

Survivability from the 1-kT nuclear device is estimated at 914.4 m (3,000 ft) [0.007 to 0.014 MPa (1 to 2 lb/in²)] range for the mirrors and approximately 457.2 m (1,500 ft) [0.020 to 0.028 MPa (3 to 4 lb/in²)] for the tower and control building. One mortar round would produce approximately 17 percent reflector damage. The probability of a direct hit on the array is very high but is low for the boiler tower and control building because a much smaller area is exposed.

The tower is highly vulnerable to sabotage because a critically placed explosive charge would demolish it. Similarly, the reflectors are vulnerable but would require many charges to be disabled. The susceptibility to vandalism and civil disturbances is also high due to the open array of reflectors, but damage is estimated to be small. It is estimated that the reflectors are capable of sustaining 40.23 to 44.70 m/s (90 to 100 mi/h) winds and the tower is capable of sustaining approximately 67.06 m/s (150 mi/h) winds. Earthquake resistance for the reflectors is high, but the tower is very susceptible due to its concentrated mass contained in the boiler mounted on top of a flexible supporting structure.

Methods to harden the system include undergrounding the control building, constructing the reflectors of a ballistically resistant material or laminating a reflective surface to the panels, strengthening the structural members, designing the structure to fail at a critical location to minimize damage, and using a perimeter fence to reduce wind forces on the heliostats. It is possible to divide the reflector array into groups, but the accuracy of the alignment system must be increased because the distances between the heliostats and boiler are greater. An alternative is to construct other tower and boiler units that would be used in parallel to generate the required power at a central control system.

(6) Radioisotope-fueled gas turbine generator--The radioisotope-fueled gas turbine generator (Figure 11) is the most compact of all the systems. For a 10-kW unit, approximately 6.50 m² (70 ft²) are required. Twenty-five units are required for 250 kW. Its operation is detailed in Section II. A standard unit was assumed to be housed in a typical operation building (light steel frame construction).

The possibility of survival from nuclear attack is governed by the structure which would be approximately 457.2 m (1,500 ft) range at 0.03 MPa (4 lb/in²). This unit would also survive a conventional weapons attack fairly well since a small amount of area is exposed. This fact is indicated by the low probability of a direct hit (Table 5). However, the compactness of the system is a disadvantage to its survivability from sabotage, to which it is highly susceptible. Vandalism and civil disturbances would cause minor damage to the system. The system is estimated to survive earthquakes of reasonable magnitude and 40.23 to 44.70 m/s (90 to 100 mi/h) winds.

Due to the compactness of the system, the only applicable method to harden it would be to locate it underground. This location would increase its nuclear survivability to 1.03 MPa (150 lb/in²) at a range of 91.44 m (300 ft).

(7) Wind energy conversion systems--The wind energy conversion systems (Figure 13) include the HAWT and VAWT, respectively. Only the VAWT was considered for the survivability analysis. The blades were assumed to be approximately 457.20 mm (18 in) wide with a total height of 45.72 m (150 ft) and turbine diameter of 30.48 m (100 ft) for a 250-kW system.

For nuclear survivability the system is estimated to withstand a 0.03 MPa (4 lb/in²) incident overpressure which equates to approximately 48.768 m (1,600 ft). A computer code analysis on a typical VAWT indicated that the supporting struts to the blades were the weak link in the system. The same effect was observed due to forces from a 71.53 m/s (160-mi/h) wind. It is estimated that very little damage would result from one mortar round. Assuming a fragment density of one fragment per 0.93 m² (10 ft²), it is estimated that less than 5 percent damage will result to VAWT blades if a mortar round impacts 21.34 m (70 ft) from the system. This would cause the blades to have

one fragment every 1.52 to 1.83 m (5 to 6 linear feet) of blade. The fragment may range from very small to 12.70 mm (one-half in) in size. Damage is repairable by means of the technology developed for helicopter blade repair.

However, the system is susceptible to sabotage, although vandalism and civil disturbances have little effect. Analyses have indicated that the VAWT with standard dynamic foundation design procedures is highly survivable to earthquakes with a factor of safety greater than two.

Methods to harden the system are limited to placing the control systems underground, leaving only the turbine blades above ground. Again, the system can be designed so that the critical components of the system (e.g., generator and gearing mechanisms) are not damaged by the oscillating action of the blades by nuclear air blast and wind forces. The turbine blades can be constructed by use of a ballistically resistant material in order to minimize fragmentation damage.

(8) Geothermal--Geothermal energy systems are the most survivable of all the energy systems discussed in this report. This claim is true because most of the components of the system are underground. It is estimated that a totally underground geothermal system would be capable of surviving a 1-kT nuclear weapon at 91.44 m (300 ft) which produces approximately 1.03 MPa (150 lb/in² overpressure. However, if the control building is located above ground, then the survival is significantly reduced to the 457.20 m (1,500 ft) range at 0.03 MPa (4 lb/in²). Conventional weapons, with the exception of a direct hit, would produce very little damage. An aboveground building is estimated to sustain 40.23 to 44.70 MPa (90 to 100 mi/h) winds. Vandalism and civil disturbances have little effect, depending on the degree of access to the system. Sabotage maintains a significant role but is the least for any of the systems. Earthquake susceptibility is estimated to be low but is dependent on the depth of the wells and proximity to the epicenter.

SECTION V DECISION MATRIX

INTRODUCTION

In this section, a decision matrix is developed in order that the parameters of acquisition cost, O&M cost, reliability and survivability of each system against nuclear threats, conventional weapons threats, sabotage, vandalism and natural disasters may be compared. For each parameter mentioned above, the system was given a rating of from 0 to a maximum of 10 for both a standard system and a hardened system. The energy systems which were rated represent the systems discussed in Section II (Table 2). A diesel generator was included for comparison.

While the ratings applied to the systems are admittedly subjective, it is felt that the comparison is fair and rational. Although the ratings were made based on the total system, at times they may be misleading. For example, the acquisition-cost rating was based on the system size from Section II and was not done on a dollar-per-kilowatt basis. This method was followed because some of the systems cannot be used for very large or very small power levels. The ratings for O&M costs and for reliability were based on the established system. In many cases, modifications could be made to improve the reliability or to reduce O&M costs of a system. Such modifications would normally increase acquisition costs and would only be carried out on the basis of an analysis of the problems or the unique requirements of a specific site.

MATRIX

Tables 6 through 14 give the ratings of the individual systems. Table 15 compares all the systems. For each parameter in Table 15, two numbers are given: the number in the upper left represents a standard system, and the number in the lower right represents a hardened system. The number of potential applications of these systems is also included. This number is based on weather data received from Environmental Technical Applications Center (ETAC). Because weather data for all sites were not received, these numbers are probably too small. Also, they are only potential figures since

TABLE 6. SYSTEM: SOLAR GAS TURBINE GENERATOR

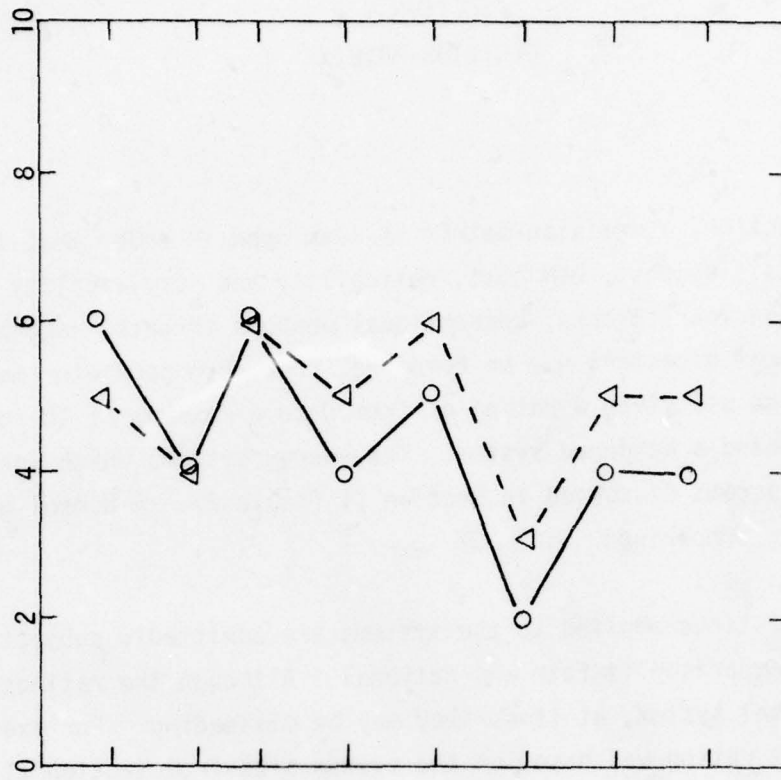

BASIC Δ

- Tracking Dish Collectors with Turbine Generator
- Control Room

HARDENED O

- Hardened Control Room
- Dispersed Collectors
- Improved Structural Design

TABLE 7. SYSTEM: SOLAR ORGANIC VAPOR TURBINE GENERATOR

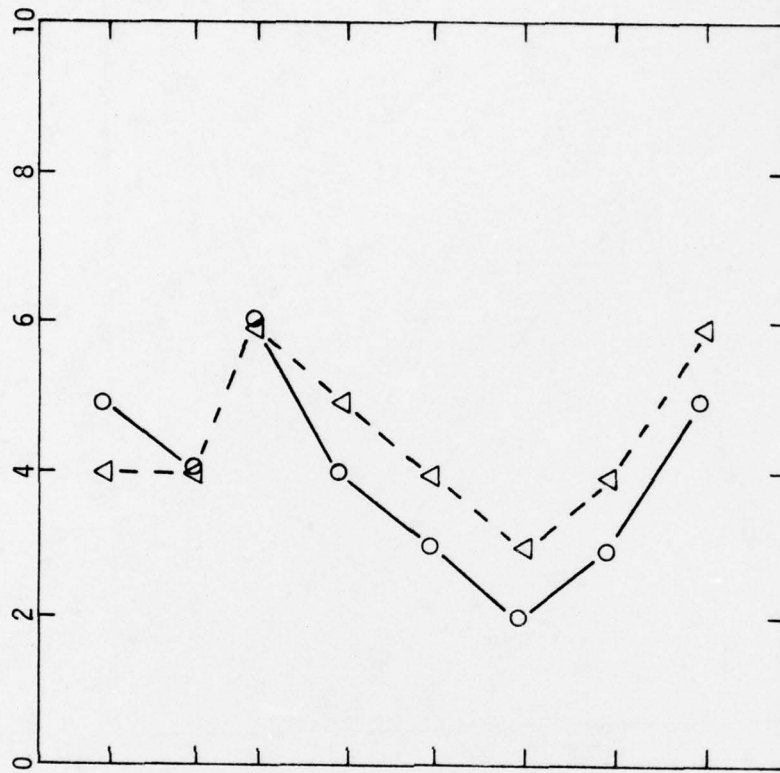

BASIC Δ

- Parabolic Single-Axis Tracking Trough Collectors
- Control Room with Turbine Generator
- Cooling Tower
- Thermal Storage

HARDENED ○

- Hardened Control Room
- Buried Storage
- Dispersed Collector Array
- Improved Structural Design

TABLE 8. SYSTEM: SOLAR PHOTOVOLTAICS

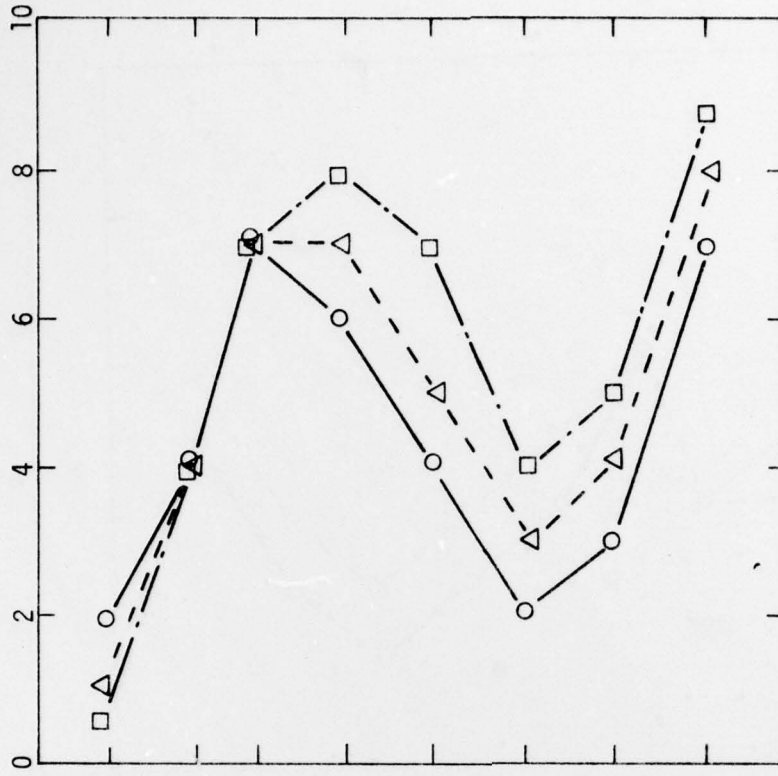

BASIC Δ

--SPV Collector

Array

--Control

Building with

Power

Conditioning

Equipment and

Battery

Storage

HARDENED ○

--Hardened

Control

Building

--Dispersed

Array

--Improved

Structural

Design

EXTRA □

HARDENING

OF FLAT PANNEL

COLLECTORS

TABLE 9. SYSTEM: SOLAR POND

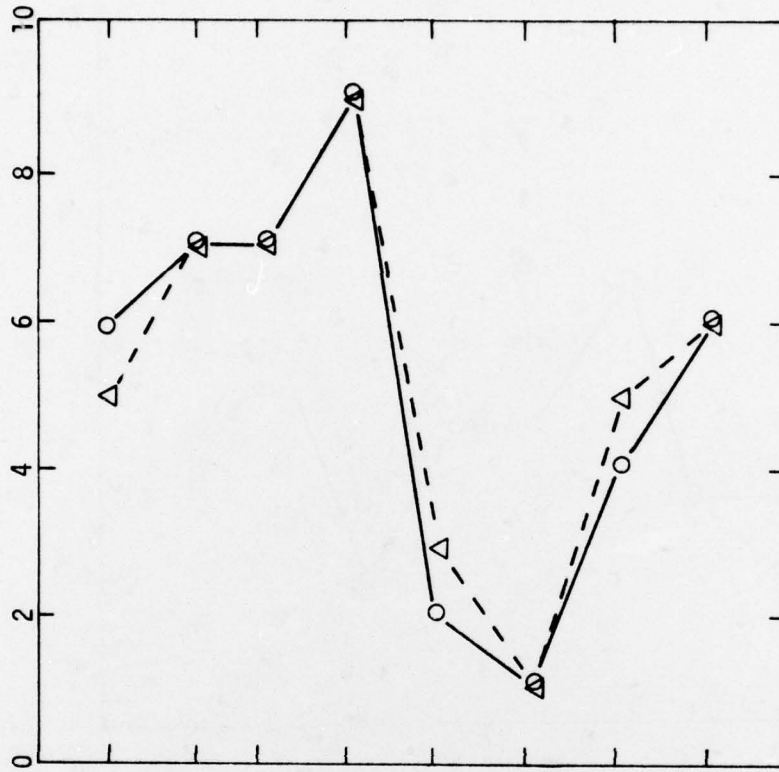

Acquisition Cost
 O&M Cost
 Reliability
 Nuclear
 Conventional
 Sabotage
 Vandalism
 Natural

BASIC Δ
 ---Pond Generator Building
 HARDENED \circ
 ---Hardened Control Building

TABLE 10. SYSTEM: SOLAR STEAM TURBINE GENERATOR

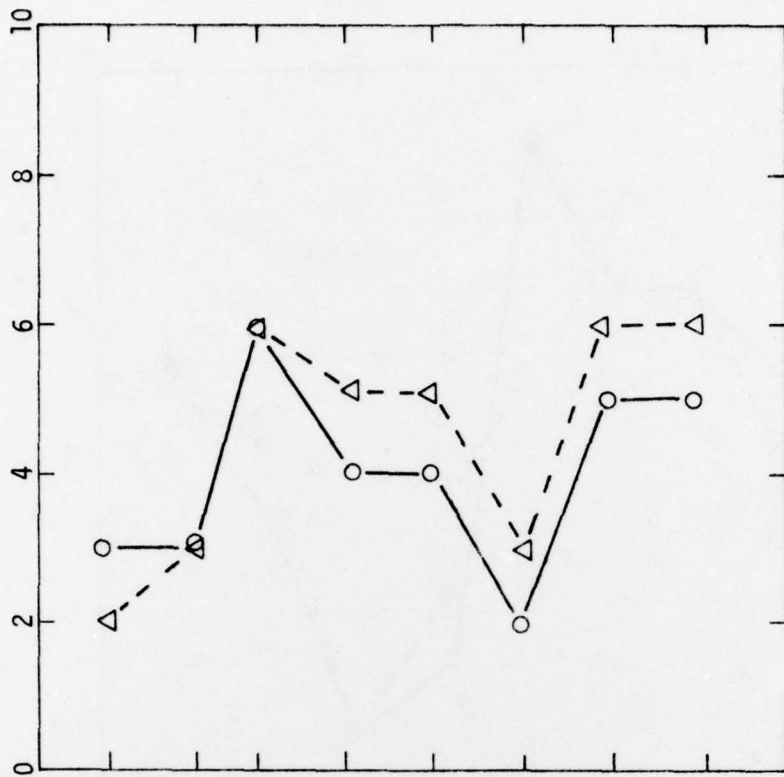

BASIC Δ

- Tower
- Heliostats
- Control Building
- Thermal Storage

HARDENED ○

- Hardened Tower
- Hardened Control Building
- Buried Storage
- Improved Structural Design

TABLE 11. SYSTEM: GAS TURBINE GENERATOR (RADIOISOTOPE FUEL)

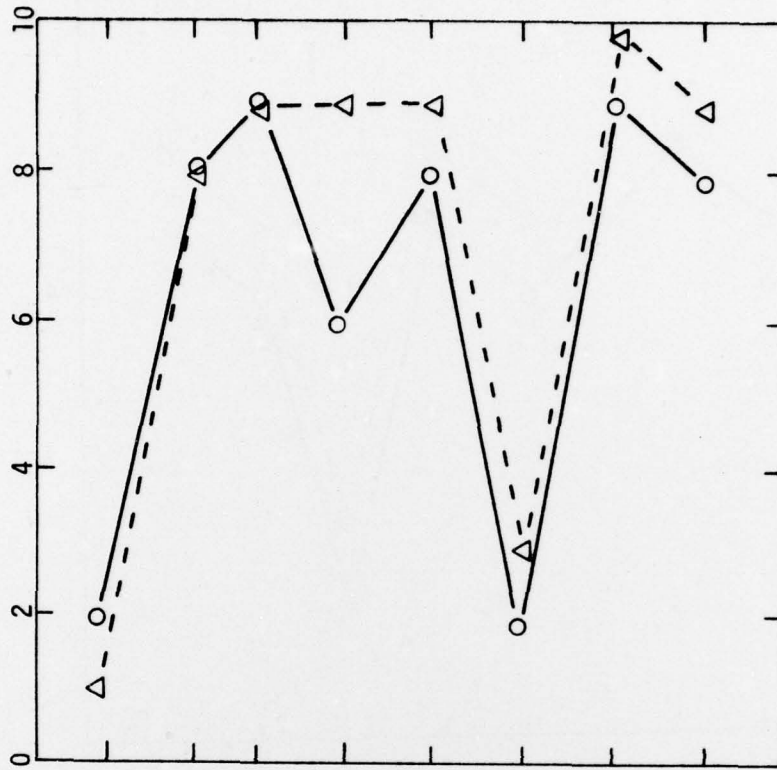

BASIC Δ
 ---Complete Unit

HARDENED O
 ---Hardened Structure to House the Unit

TABLE 12. SYSTEM: WIND ENERGY CONVERSION MATRIX

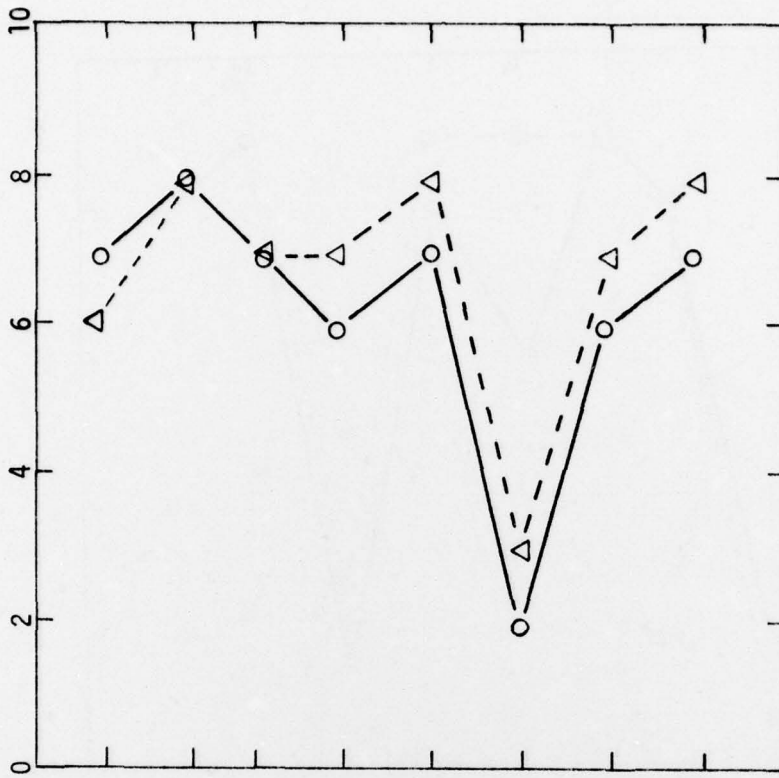

BASIC Δ
 --Wind Turbine
 --Tower and Tie-Downs
 --Control Building with Power Conditioning and Equipment and Battery Storage

HARDENED ○
 --Hardened Turbine
 --Hardened Control Building

TABLE 13. SYSTEM: GEOTHERMAL

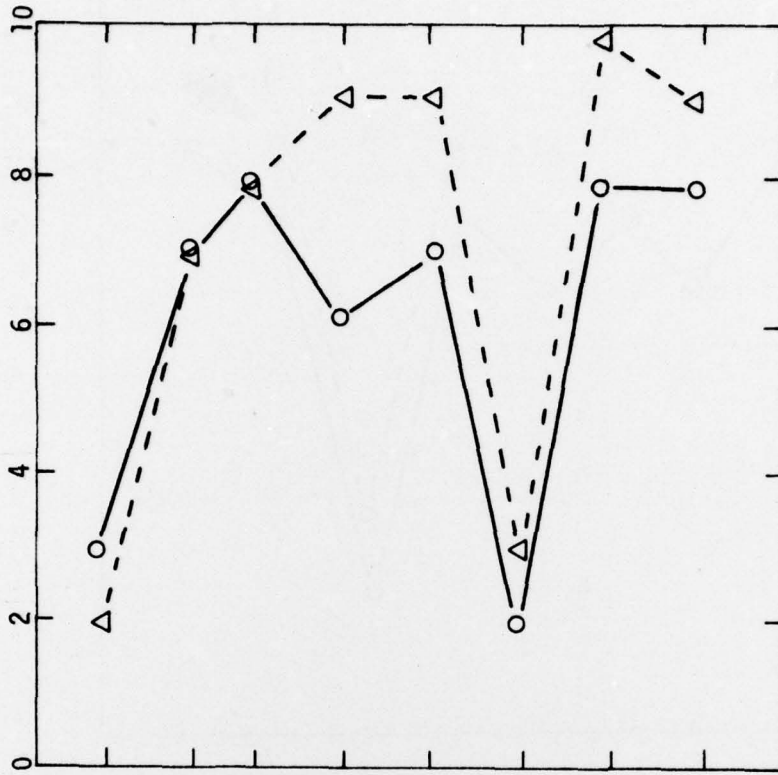

Acquisition Cost

O&M Cost

Reliability

Nuclear

Conventional

Sabotage

Vandalism

Natural

BASIC Δ

--Production Well

--Reinjection Well

--Building Housing Turbine, Generator, Pumps, and Controls

HARDENED \circ

--Hardened Structure to House Entire Unit

TABLE 14. SYSTEM: DIESEL GENERATOR

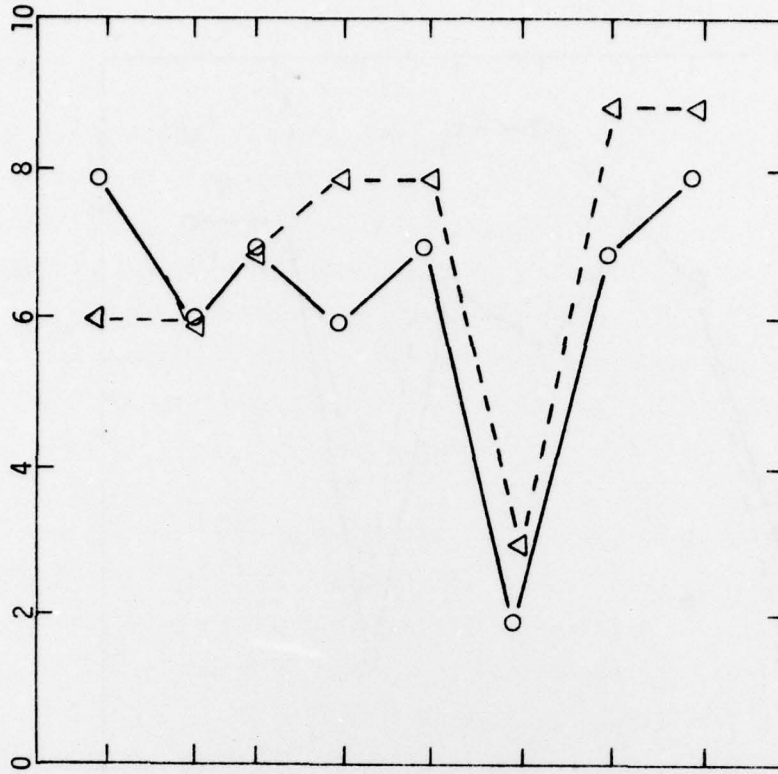

BASIC ▲

- Diesel Engine
- Generator
- Control System
- Fuel System
- Exhaust System
- Cooling System

HARDENED ○

- Hardened Structure to House the Unit
- Hardened Fuel Storage Tanks

TABLE 15. DECISION MATRIX

SYSTEMS	Diesel Generator	Solar Gas Turbine Generator	Solar Organic Vapor Turbine Generator	Solar Photo-voltaics	Solar Pond	Solar Steam Turbine Generator	Radio-isotope Fuel Gas Turbine Generator	Wind Energy Conversion System	Geo-Thermal
Number of Potential Applications	148	24	24	24	24	24	24	40	5
Acquisition Cost	8*	6	5	2	6	3	2	7	3
Maintenance and Operation Cost	6**	4	4	4	7	3	8	8	2
Reliability	6	4	4	4	7	3	8	7	7
Survivability Nuclear	7	6	6	7	7	6	9	7	8
Survivability Conventional	7	4	4	6	9	4	6	6	6
Sabotage	8	5	5	7	9	5	9	7	9
Vandalism	7	5	3	4	2	4	8	7	7
Natural Disasters	2	2	2	2	1	2	2	2	2
	3	3	3	3	1	3	3	3	3
	7	4	3	3	4	5	9	6	8
	9	5	4	4	5	6	10	7	10
	8	4	5	7	6	5	8	7	8
	9	5	6	8	6	6	9	8	9

Weighting Factor (see Text)

* The first number represents a standard system
 ** The second number represents a hardened system.

a site-specific study is needed for a positive determination. Also included along side the parameters is a block for a Weighting Factor (from 0.0 to 1.0).

The purpose of the Weighting Factor is to allow for variations at specific sites. For example, at DEW sites, it is doubtful that vandalism is much of a threat because of the sites' isolation. Thus the Weighting Factor is very small or even zero. On the other hand, reliability is very important because of this same isolation. Here the Weighting Factor is large (1.0). Once a Weighting Factor has been applied to each parameter, it is multiplied by a value for each system analyzed. These numbers are then added together and divided by the number of parameters. This number is then multiplied by 10 to yield a percentage value. An example of this computation is provided below.

For this example, BAR-Main on Barter Island, Alaska, was studied. BAR-Main is a DEW site under the ADC. It has a power requirement of 600 kW which is currently supplied by a diesel generator; arctic diesel fuel is sea-lifted in. BAR-Main has a fair wind potential with an average annual wind speed of 5.77 m/s (12.9 mi/h). BAR-Main also appears to have a fair solar potential from April to August when the winds are lowest. Due to the fact that the solar potential is only part-time, it was decided that solar systems are not applicable; thus the analysis is limited to the diesel generator and WECS systems. The radioisotope-fueled gas turbine generator was ignored because of its small power capabilities, and geothermal was also ignored due to lack of information on the local geothermal potential.

Next, the Weighting Factors are to be determined. Acquisition cost is important and given a value of 0.8. O&M costs and reliability are very important and assigned a value of 1.0. Since this is a small base, the nuclear threat level is low, making the Weighting Factor 0.3. Conventional weapons pose a larger threat and are given a 0.7. Sabotage is always a possible threat and is given a 0.8. Due to the isolation of the site, vandalism is low, and the Weighting Factor is set at 0.2. The problems of natural disasters is high due to the arctic climate, and the Weighting Factor is given as 0.9. It is determined that a hardened system is not required and thus Table 16 is established.

TABLE 16. EXAMPLE OF USE OF DECISION MATRIX

	Weighting Factor	Diesel Generator		WECS	
		Raw	x WF	Raw	x WF
Acquisition Cost	0.8	8	6.4	7	5.6
Operation and Maintenance Costs	1.0	6	6.0	8	8.0
Reliability	1.0	7	7.0	7	7.0
Nuclear	0.3	6	1.8	6	1.8
Conventional	0.7	7	4.9	7	4.9
Sabotage	0.8	2	1.6	2	1.6
Vandalism	0.2	7	1.4	6	1.4
Natural Disasters	0.9	8	7.2	7	7.2
Total			36.3		37.5
+8, x 10			45.4 Percent		46.9 Percent

These numbers are then added up, divided by the number of parameters and multiplied by 10 to yield a value of 45.4 percent for the diesel generator and a value of 46.9 percent for the wind system. From this analysis, the WECS appears slightly better than the diesel generator. Without the Weighting Factors, the diesel generator would have been slightly better: 63.8 to 63.5 percent.

This analysis is intended to be only a guideline for establishing further study areas and was not designed to be a final decision tool. The final decision must be made on the basis of more specific information.

BIBLIOGRAPHY

- Advanced Energy Programs, Space Division, General Electric Co. *Final Report: 2 kW(e) Unattended Power System Study*. Contract No. E(49-15)-3082, Prepared for ERDA, April, 1977.
- Baker, W., et al. *Non-nuclear Weapons Effects on Protective Structures*. AFWL-TR-69-57, Air Force Weapons Laboratory, Kirtland AFB, NM, 1969.
- Berkowitz, Joan B. and H. P. Silverman, *Proceedings of the Symposium on Energy Storage*, Princeton, NJ, The Electrochemical Society, 1976.
- Carlson, A., et al. *USAF Terrestrial Energy Study*. Air Force Aeropropulsion Laboratory, Air Force Systems Command, Wright-Patterson AFB, OH, Technical Report AFAPL-TR-78-19, February, 1978.
- Chapyak, E. J., and Cooper, H. F. *Simulation of Fluid Motion in Containers Exposed to Blast and Shock Environments*. 4th International Symposium on Military Applications of Blast Simulations, September, 1974.
- Clark, Wilson. *Energy for Survival*. Garden City, NY: Anchor Books, 1974.
- Corps of Engineers, Office of the Chief of Engineers. *Fundamentals of Protective Design*. 1946.
- Crawford, Robert E., et al. *Protection from Non-Nuclear Weapons*. AFWL-TR-70-127, February, 1970.
- Crawford, Robert E., Higgins, C. J., Bultmann, E. H. *Air Force Manual for Design and Analysis of Hardened Structures*. AFWL-TR-74-102, October, 1974.
- Daly, Leo A. *Cold Region Energy Study*. A study by Air Force Civil Engineering Center, prepared by Leo A. Daly. Contract No. F08635-76-C-0348, January, 1977.
- de Winter, Francis and Cox, Michael. *Sun: Mankind's Future Source of Energy*. Vol. I, New York, Pergamon Press, 1978.
- Duffie, John A., and Beckman, William A. *Solar Energy Thermal Processes*. New York: John Wiley and Sons, Inc., 1974.
- Effects of Impact and Explosion*. Office of Scientific Research and Development, National Defense Research Committee. Washington, DC: U. S. Government Printing Office, 1977.
- Glasstone, S. (ed.). *The Effects of Nuclear Weapons*. U. S. Atomic Energy Commission, April, 1962.
- Kando, Paul F., "Electric Salts", *Solar Age*, III, No. 4 (April, 1978), 15.
- Krenz, Jerrold H. *Energy Conversion and Utilization*. Boston: Allyn and Bacon, Inc., 1974.

- Leckie, Jim, et al. *Other Homes and Garbage*. San Francisco: Sierra Club Books, 1975.
- Murphy, Leonard. *San Fernando, California, Earthquakes of February 9, 1971, Vol. II, Utilities, Transportation, and Sociological Aspects*. Washington, DC, U. S. Department of Commerce, 1973.
- Office of Technology Assessment. *Application of Solar Technology for Today's Energy Needs*. Vol. 1. Stock No. 052-003-00539-5. Washington, DC: U. S. Government Printing Office, June, 1978.
- Protective Construction Concepts*. Ralph M. Parsons Co., November, 1968.
- Skinrood, A. C. "Barstow: Prototypical Power Tower," *Solar Age*, III, No. 6 (June, 1978), 24.
- Surface, Michael Otis, "Exotic Power and Energy Storage," *Power Engineering*, December, 1977, 36.
- U. S. Departments of the Air Force, Army and Navy. *Engineering Weather Data*. AFM 88-29. July, 1978
- Van Wylen, Gordon J., and Sonntag, Richard E. *Fundamentals of Classical Thermodynamics*. New York: John Wiley and Sons, Inc., 1973
- Zangrando, Federico, and Bryant, H. C. "A Salt Gradient Solar Pond," *Solar Age*, III, No. 4 (April, 1978), 21.
- _____. "Battery and Fuel Cell Technology," *Automotive Engineering*, 86, No. 7 (July, 1978), 68.
- _____. "Solar Power Tower Over Europe," *New Scientist*, LXXVI (Nov. 24, 1977), 470.

INITIAL DISTRIBUTION

OASD/(MRA&L) EES	1	HQ USAF/LEY	1
US Army/CERL	1	HQ USAF/LEE	1
US Army/DAEN-RDM	1	HQ USAF/RD	1
US Army FESA	1	OSAF/MIQ	1
AFIT/Library	1	OSAF/RD	1
AFIT/DE	1	HQ AFSC/DE	1
NCEL, Code 25111	1	HQ AFSC/DLWM	1
DDC/DDA	2	HQ AFSC/SD	1
HQ AFESC/DEB	2	HQ ADCOM/DE	1
AEDC/DE	1	HQ USAFA/DE	1
HQ AFESC/TST	2	HQ USAFA/Library	1
		HQ TAC/DE	1
HQ AFESC/RDV	1	HQ SAC/DE	1
HQ AFESC/RDVA	30	HQ MAC/DE	1
		HQ AFSC/DE	1
ADTC/DL	1	HQ ATC/DE	1
DOE/ET-50	2	HQ AAC/DE	1
DOE/CS	2	HQ AFLC/DE	1
DOE/ET	2	HQ USAFSS/DE	1
AFAPL/STINFO	2	HQ USAFE	1
AFAPL/CCN	1	HQ PACAF/DE	1
AFAL/TSR	1	AFOSR/CC	1
UNM/CERF	7	HQ AUL/LSE 71-249	1
		AFAPL/POE	1