

AD-A078 204

ARMY COMMUNICATIONS-ELECTRONICS ENGINEERING INSTALLAT--ETC F/6 17/7
STANDARD ENGINEERING INSTALLATION PACKAGE, NONDIRECTIONAL, BEACO--ETC(U)
NOV 79

UNCLASSIFIED USACEEIA-SEIP-013

NL

1 OF 2
AD
A078204



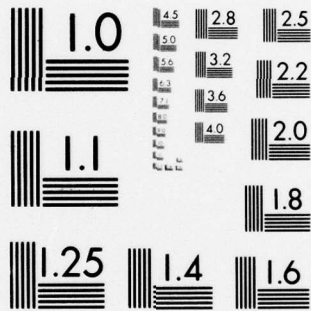

MICROCOPY RESOLUTION TEST CHART
NATIONAL BUREAU OF STANDARDS-1963-A

LEVEL

AD

SEIP 013



AD A 078204

**U
S
A
C
E
E
I
A**

**STANDARD
ENGINEERING INSTALLATION PACKAGE**

NONDIRECTIONAL BEACON

DDC FILE COPY

**DDC
RECEIVED
DEC 14 1979
D**

15 NOVEMBER 1979

APPROVED FOR PUBLIC RELEASE. DISTRIBUTION UNLIMITED.

**HEADQUARTERS
US ARMY COMMUNICATIONS-ELECTRONICS
ENGINEERING INSTALLATION AGENCY
FORT HUACHUCA, ARIZONA 85613**

79 12 12 006

DISPOSITION INSTRUCTIONS

Destroy this document when no longer needed.
Do not return it to the originator.

DISCLAIMER

The use of trade names in this document does not constitute an official endorsement or approval of the use of such commercial hardware or software. This document may not be cited for purposes of advertisement.

AVAILABILITY

This publication is available to non-Government agencies and may be purchased through the Defense Documentation Center, Cameron Station, Alexandria, VA 22314.

Government activities may requisition copies by writing to the Commander, Headquarters, Fort Huachuca, ATTN: CCH-PCA-ASP, Fort Huachuca, Arizona 85613.

NEUTRAL LANGUAGE

The word "he" when used in this publication represents both the masculine and feminine genders, unless specifically stated otherwise.

CERTIFICATION

The certifications/verifications contained in this publication are essential to the conduct of the business of the Government.

Unclassified

SECURITY CLASSIFICATION OF THIS PAGE (When Data Entered)

REPORT DOCUMENTATION PAGE		READ INSTRUCTIONS BEFORE COMPLETING FORM
1. REPORT NUMBER SEIP 013	2. GOVT ACCESSION NO.	3. RECIPIENT'S CATALOG NUMBER 9
4. TITLE (and Subtitle) 6 Standard Engineering Installation Package. Nondirectional Beacon.		5. TYPE OF REPORT & PERIOD COVERED Final Indefinite ^{Sept}
		6. PERFORMING ORG. REPORT NUMBER
7. AUTHOR(s)	8. CONTRACT OR GRANT NUMBER(s) 12 118	
9. PERFORMING ORGANIZATION NAME AND ADDRESS US Army Communications-Electronics Engineering Installation Agency, ATTN: CCC-CED-SEP Ft. Huachuca, AZ 85613		10. PROGRAM ELEMENT, PROJECT, TASK AREA & WORK UNIT NUMBERS 11
11. CONTROLLING OFFICE NAME AND ADDRESS US Army Communications Electronics Engineering Installation Agency, ATTN: CCC-CED-SEP Ft. Huachuca, AZ 85613		12. REPORT DATE 15 November 1979
14. MONITORING AGENCY NAME & ADDRESS (if different from Controlling Office) US Army Communications-Electronics Engineering Installation Agency, ATTN: CCC-CED-SEP Ft. Huachuca, AZ 85613		13. NUMBER OF PAGES
		15. SECURITY CLASS. (of this report) Unclassified
16. DISTRIBUTION STATEMENT (of this Report) 14 USACEEIA-SEIP-013		15a. DECLASSIFICATION/DOWNGRADING SCHEDULE
17. DISTRIBUTION STATEMENT (of the abstract entered in Block 20, if different from Report)		
18. SUPPLEMENTARY NOTES		
19. KEY WORDS (Continue on reverse side if necessary and identify by block number) Nondirectional beacon (NDB) Monopole antenna Beacon Counterpoise Balanced-T antenna NAVAIID		
20. ABSTRACT (Continue on reverse side if necessary and identify by block number) This Standard Engineering Installation Package (SEIP) provides information for the engineering and installation of NDB facilities worldwide. Information provided consists of site survey data, siting criteria, installation specifications and instructions, a bill of materials, quality assurance procedures and completion certification format. Information provided must be adapted to the specific NDB facility/location by the project engineer. -405 982 JOB		

DEPARTMENT OF THE ARMY
HEADQUARTERS. US ARMY COMMUNICATIONS-ELECTRONICS
ENGINEERING INSTALLATION AGENCY
Fort Huachuca, Arizona 85613

USACEEIA SEIP
No. 013

STANDARD ENGINEERING INSTALLATION PACKAGE
NONDIRECTIONAL BEACON

Paragraph		Page
<u>SECTION 1. GENERAL</u>		
1.1	PURPOSE.	1-1
1.2	SCOPE.	1-1
1.3	APPLICABLE DOCUMENTS	1-1
1.4	DEFINITIONS OF TERMS	1-3
1.5	BACKGROUND	1-3
1.6	OTHER CONSIDERATIONS	1-3
1.7	SYSTEM DESCRIPTION	1-4
1.8	COMMENTS ON PUBLICATION.	1-11
<u>SECTION 2. SITE SURVEY DATA AND CHECKLIST</u>		
2.1	GENERAL.	2-1
2.2	SITE SELECTION	2-1
2.3	SITING CRITERIA.	2-1
2.4	SITE SURVEY CRITERIA	2-2
2.5	SITE SURVEY CHECKLIST.	2-3
2.6	SITE SUPPORT REQUIREMENTS.	2-3
2.7	EQUIPMENT CHARACTERISTICS.	2-4
<u>SECTION 3. INSTALLATION SPECIFICATIONS AND INSTRUCTIONS</u>		
3.1	INTRODUCTION	3-1
3.2	GENERAL INSTRUCTIONS	3-1
3.3	INSTALLATION INSTRUCTIONS.	3-2
<u>SECTION 4. ENGINEERING INSTALLATION DRAWINGS</u>		
4.1	GENERAL.	4-1
4.2	MODIFICATION OF INSTALLATION DRAWINGS.	4-1
<u>SECTION 5. BILL OF MATERIALS</u>		
5.1	GENERAL.	5-1
5.2	BILL OF MATERIALS.	5-1

TABLE OF CONTENTS (Continued)

Paragraph	Page
<u>SECTION 6. QUALITY ASSURANCE PROCEDURES</u>	
6.1 GENERAL	6-1
6.2 QUALITY ASSURANCE PROGRAM	6-1
6.3 SPECIAL CONSIDERATIONS	6-5
<u>SECTION 7. OPERATIONAL TEST PLAN AND CHECKOUT PROCEDURES</u>	
7.1 GENERAL	7-1
7.2 TESTING	7-1
<u>SECTION 8. COMPLETION CERTIFICATION</u>	
8.1 GENERAL	8-1
8.2 DISTRIBUTION	8-1
8.3 WAIVERS	8-1
8.4 TAR PREPARATION INSTRUCTIONS	8-1

LIST OF ILLUSTRATIONS

Figure No.	Page
1-1 NDB Single Transmitter Block Diagram	1-5
1-2 NDB Dual Transmitter Block Diagram	1-6
2-1 Sample Site Survey Checklist	2-7
5-1 Bill of Materials	5-2
6-1 QA Points of Contact	6-6
6-2 QA Inspection Checklist - Installation	6-7
6-3 QC Checklist - Installation	6-20
8-1 Technical Acceptance Recommendation	8-5

LIST OF TABLES

Table No.	Page
2-1 Equipment Characteristics	2-5

Accession For	
NTIS GRA&I	<input checked="" type="checkbox"/>
DDC TAB	<input type="checkbox"/>
Unannounced	<input type="checkbox"/>
Justification	<input type="checkbox"/>
By _____	
Distribution/ _____	
Availability Codes	
Dist.	Avail and/or special
A	

SECTION 1. GENERAL

1.1 PURPOSE. The purpose of this Standard Engineering Installation Package (SEIP) is to provide detailed guidance for the engineering, installation, and testing of the nondirectional beacon (NDB) navigational aid (NAVAID) facility.

1.2 SCOPE. This SEIP is applicable to all US Army Communications Command (USACC) engineering-installation activities involved in the planning and implementation of NDBs. This SEIP provides site survey data, engineering and installation specifications and instructions, typical installation drawings, a Bill of Materials (BOM), quality assurance and test and acceptance procedures, and completion certification format.

1.3 APPLICABLE DOCUMENTS.1.3.1 Government Documentsa. Manuals.

TM 5-803-4	Planning of Army Aviation Facilities
FM 11-486-23	Telecommunications Engineering: Air Traffic Control Facilities and Systems
TM 95-226	US Standard for Terminal Instrument Procedures (TERPS)
USAF T.O. 31-10 Series	Standard Installation Practices

b. Regulations

AR 105-6	C-E Standardized Telecommunications Program
CCR 702-1-2	USACC Quality Assurance Program for Engineering, Installation, and Acceptance of Communications-Electronics Equipment and Systems.
CCR 385-1	Communications Safety
CCCR 34-2	Preparation of Engineering Installation Packages and Standard Engineering Installation Packages

- CCCR 702-1 USACEEIA Quality Assurance and Testing Program
- CCCR 702-2 Preparation of Documentation for Test and Evaluation of Communications-Electronics Material
- CCCR 702-3 Role of the Test Director
- CCCR 702-4 Quality Assurance During On-Site Installation
- CCCR 702-7 Product Assurance Quality Assurance Corrective Actions
- c. Handbooks
- MIL-HDBK-232 RED/BLACK Engineering Installation Guidelines (U)
- d. Technical Bulletin
- TB 95-1 US Army Air Traffic Control and NAVAID Facility Standards
- e. Circular
- DCAC 370-160-3 Site Survey Data Book for Communications Facilities
- f. Miscellaneous
- USACEI Bn Pamphlet 105-3 The Communications-Electronics Installation Planning and Implementation Guide
- CCP 700-20 List of Nonadopted Commercial Items of Equipment
- CCC-TED-75-TP-200 Quality Assurance Evaluation and Technical Acceptance Test of World-Wide Army Airfields/Heliports Communications and Navigational Aids (Revision 2) Test Plan

15 November 1979

SEIP 013

SEIP 010 Standard Engineering Installation Package,
US Army Airfield/Heliport Air/Ground
Communications

SEIP 020 Uninterruptible Power Facilities--48 V dc

1.3.2 Non-Government Documents

NFPA 70-XXXX National Electrical Code (Current edition)

NDB Transmitter Manufacturer's manual (Nautel)
Manual

Monopole Antenna Manufacturer's manual (Polestar)
Manual

1.4 DEFINITION OF TERMS.

Balanced-T antenna. An antenna consisting of a horizontal wire connected to and bisected by a vertical wire extending downward. The vertical wire is the radiator; the horizontal wire provides capacitive loading.

Capacitance. The property of a circuit or body that enables it to store an electrical charge and, hence, to transmit alternating currents.

Conductivity. The capability of a substance to transmit electricity; the reciprocal of resistivity.

Counterpoise. An array of conductors beneath an antenna.

Monopole antenna. An antenna, usually vertical, consisting of a single radiating element.

Nondirectional beacon. A low frequency (lf)/medium frequency (mf) radio transmitting station used with airborne automatic direction finders. Usually referred to as NDB. Same as compass locator and H-beacon.

1.5 BACKGROUND. This SEIP is prepared in accordance with US Army Communications Command (USACC) Supplement 1 to AR 105-6, C-E Standardized Telecommunications Program.

1.6 OTHER CONSIDERATIONS. RED/BLACK criteria have not been covered in this document. Refer to MIL-HDBK-232 for details.

1.7 SYSTEM DESCRIPTION. The NDB is an lf/mf radio beacon that radiates an omnidirectional signal for use in aircraft navigation. Station identification is provided in Morse code by tone modulation of the carrier. Voice transmission capability is provided at the NDB transmitter site. However, in this SEIP no voice capability is provided at the monitor site. The voice capability of the NDB transmitter will be used as required to transmit a 2600-Hz tone indicating ac power failure (see 1.7.7). The facility consists of a transmitter shelter, single or dual transmitters, transmitter changeover unit (dual-transmitter sites), antenna tuning unit, battery backup power system, monitor/alarm receiver with antenna, ac power failure indicator, antenna system, and a counterpoise/ground system. The shelter houses the transmitter, the changeover unit, the antenna tuning unit (with balanced-T antenna), and the backup power supply. The monitor/alarm receiver and the ac power failure indicator receiving unit are remotely located. Figure 1-1 is a single transmitter facility block diagram and figure 1-2 is a dual transmitter facility block diagram.

1.7.1 Shelter. The shelter interior is 7 feet 5 inches (226 cm) wide by 9 feet 5 inches (287 cm) long by 8 feet (244 cm) high. It is manufactured of polyurethane core walls with a fiberglass coat inside and outside. The sidewalls and roof are an integral unit. The shelter comes with a circuit breaker panel containing a 100-A main breaker and eight 15-A circuit breakers; four 100-W incandescent lights, four duplex outlets, an exterior light; and an 850 cubic-foot-per-minute, 12-inch exhaust fan with motorized louvers.

1.7.2 Beacon Transmitter. The NDB transmitter operates on an input voltage of 102 to 138 V ac or 204 to 276 V ac and an input frequency of 47.5 Hz to 63 Hz. The transmitter is a totally solid state unit designed for continuous operation with an output of up to 50 watts. The transmitter is amplitude modulated by an internally generated tone, keyed on/off for station identification by a programmable keying circuit, which may be adjusted for any two- or three-letter code. A compression amplifier and audio filter provide for simultaneous station identification and voice modulation. (This SEIP does not provide voice capability from the monitor/alarm site.) The transmitter operates in the frequency range of 190 to 535 kHz. The transmitter has internal capability for automatic shutdown when the carrier or modulation level exceeds preset limits.

1.7.3 Beacon Transmitter Changeover Unit. The changeover unit is utilized where a dual beacon facility is installed. The changeover unit is controlled by the failure-sensing/shutdown circuitry contained in each transmitter. When a shutdown is initiated in the primary transmitter, the changeover unit transfers to the backup transmitter within 20 to 35 seconds. A subsequent failure of the backup transmitter results in a shutdown of this transmitter. The NDB will remain in the shutdown state until one transmitter is manually restored to operating status.

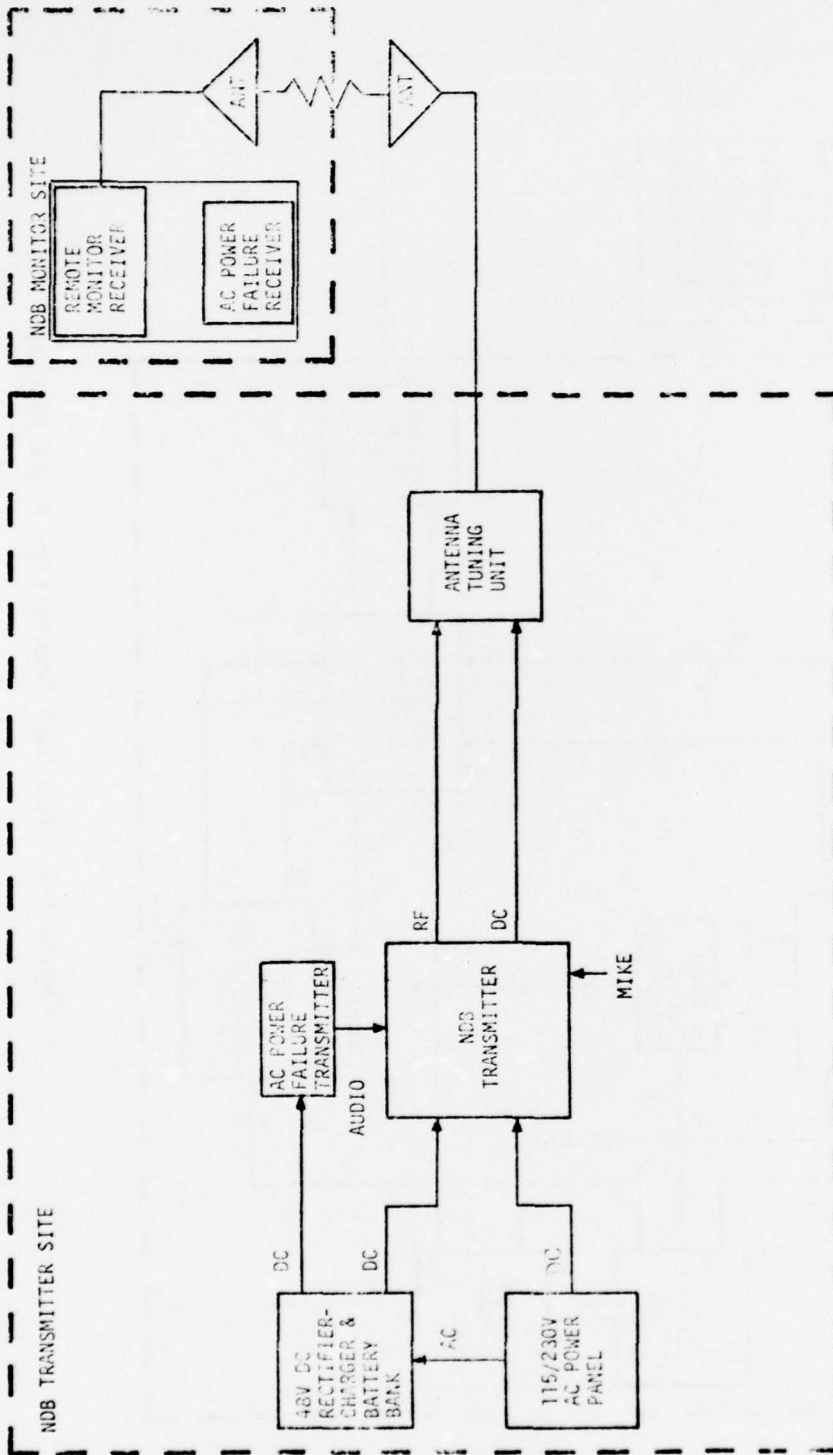

Figure 1-1. NDB Single Transmitter Block Diagram.

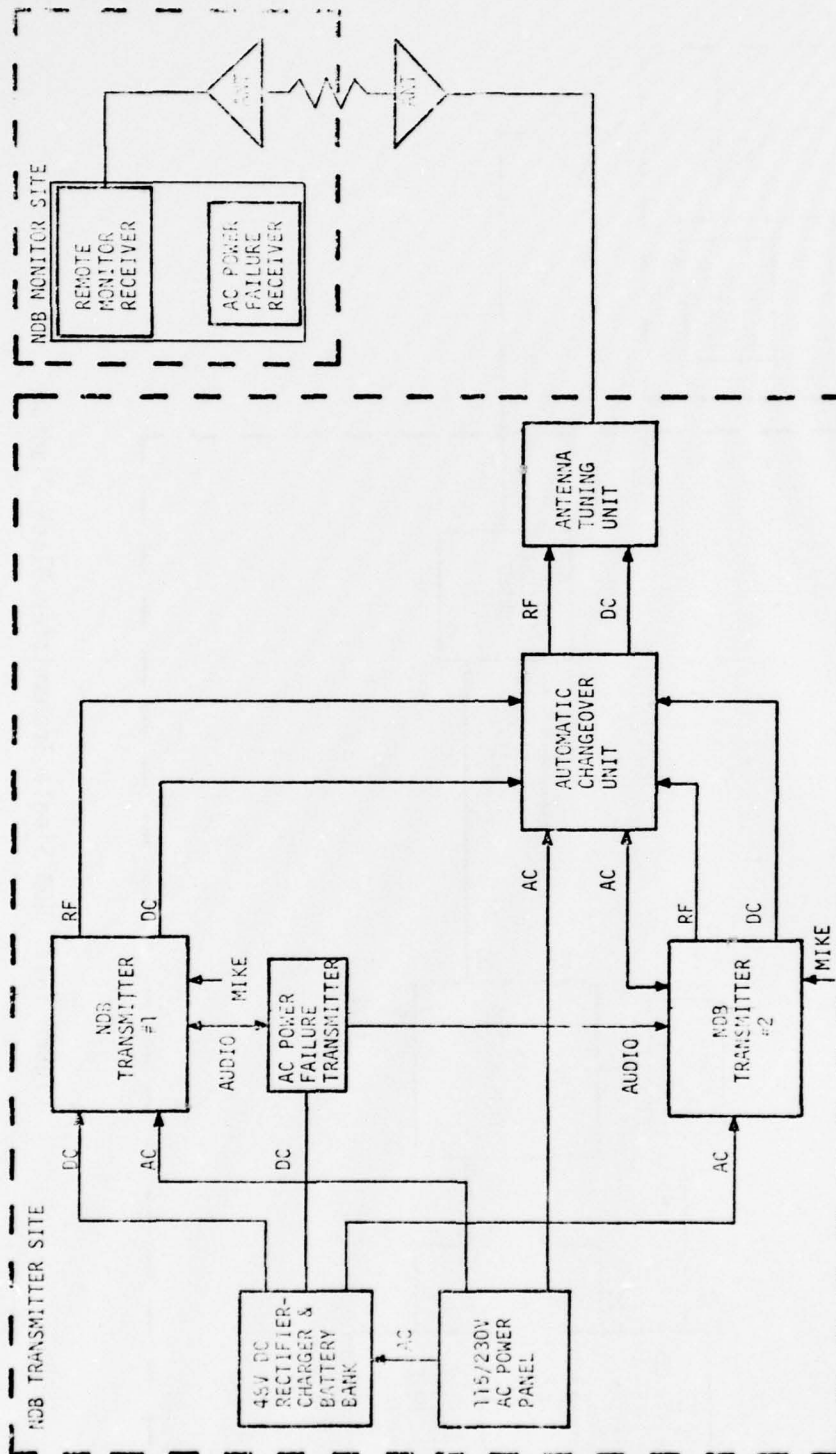

Figure 1-2. NDB Dual Transmitter Block Diagram.

1.7.4 Antenna Tuning Unit. The antenna tuning unit matches the impedance of the antenna to that of the transmitter output. It automatically compensates for variations in antenna reactance caused by environmental changes while the system is in operation. Where the balanced-T antenna is used, the FA 9782/1 antenna tuning unit is mounted in the shelter. Where the monopole antenna is used, it is shipped with its own tuning unit which mounts on the antenna mast. (See 1.7.8 for description of antennas.)

1.7.5 Backup Battery Supply. The backup battery supply consists of a 48-V dc rectifier-charger and four 12-V dc, automotive type, maintenance-free batteries. This battery supply is capable of operating a dual beacon facility for 12 hours, with a recharge time of 12 hours.

1.7.6 Monitor/Alarm Receiver. The monitor/alarm receiver is located in the tower cab or other area dictated by local operational requirements. This receiver, using a whip antenna, receives the on-the-air signal from the beacon antenna. Whenever there is a change in rf signal or identification tone that exceeds the receiver's preset tolerances, visual and audible alarms are activated.

1.7.7 Ac Power Failure Indicator. One of two methods is used to provide an indication at the monitoring site when the transmitter is operating on battery power because of ac power failure.

1.7.7.1 Landline Transmission. At those sites which have existing signal cable, one pair of the cable can be used to remote the ac power failure indication to the tower cab.

a. At the transmitter site, one protected pair is connected from the rectifier-charger ac power failure relay to the outside plant protector block. No additional equipment is required at the transmitter site.

b. At the control tower, the indicator panel can usually be mounted in the NAVAIID console. When the monitoring site is not the control tower, or where console space is not available, a small cabinet enclosure can be provided. The panel contains a dual lamp assembly and an audible alarm unit which generates a steady tone at a frequency of about 2900 Hz at an audio level of 68-80 dB. Three adjustable resistors are provided to compensate for various line loop resistances.

c. At sites using a landline for transmission of indication of ac power failure, no use is made of the NDB's voice capability. At such sites the station identification keying tone shall be adjusted to provide a modulation level of 90 percent.

1.7.7.2 Radiated Transmission.

a. Where no landlines are available, the ac power failure indication is transmitted by the NDB transmitter and received by the monitor receiver in the control tower. The ac power failure relay contacts in the rectifier-charger operate the "M" lead of a telephone-type, single-frequency signaling unit (SFSU) to provide adjustable level 2600-Hz tone to the voice input of the NDB. A small dc-to-dc converter module operating from the NDB +48 V battery supply provides the -48 V dc necessary to operate the SFSU. The failure indication persists as long as ac power is off at the NDB location. The monitor receiver volume control can be used to reduce or silence the tone.

b. At sites using the NDB radiated signal to transmit the indication of ac power failure, the sum of the modulations produced by the station identification keying tone and the 2600-Hz tone must not exceed 90 percent. The modulation produced by the identification tone shall be adjusted to 70 percent and the modulation produced by the 2600-Hz tone shall be adjusted to 20 percent.

1.7.8 Antenna Considerations. Because of its location on or near to the airfield, the NDB antenna height must be limited. Also, an omnidirectional radiation pattern is desired. Low cost and a simple structure are other desired properties. These considerations practically dictate an electrically "short" vertical radiator, with capacitive top loading, and a ground-level, radial counterpoise. The vertical radiator is limited to a small fraction of a quarter wavelength at the operating frequency (195-535 kHz). Capacitive top loading raises the antenna current in the short radiator, which improves radiation efficiency and therefore increases the range. The counterpoise at ground level lowers the feedpoint resistance, which also improves radiation efficiency.

a. Physical description. This SEIP provides a choice of antennas--a balanced-T for most sites and a monopole where space for the balanced-T is not available or where it is necessary to remote the antenna from the transmitter. The balanced-T antenna consists of a vertical wire radiator top-loaded by a horizontal wire. The horizontal wire is supported by a pole at each end. The monopole consists of a rigid, guyed, vertical radiator loaded with self-supporting radial elements at the top. The monopole is factory tuned to a specific frequency.

b. Design parameters. The range and radiation patterns of the NDB depend on the factors below, listed in approximate order of importance:

- (1) Length of vertical radiator.
- (2) Power input to the antenna.
- (3) Antenna height above average ground level.
- (4) Capacitance of top load to ground.
- (5) Length of counterpoise radials.
- (6) Number of counterpoise radials.
- (7) Soil conductivity.
- (8) Termination of radials.

c. Radiator length. Radiation efficiency increases rapidly with increasing radiator length up to a quarter of a wavelength at the operating frequency. For practical purposes, lengths from 15 to 50 feet (5 to 15 m) are used in the bridged-T antenna, depending on the desired range and physical height limitation imposed. The monopole length is fixed at 40 feet. A loading coil in the NDB antenna tuning unit compensates for the reduced length at the expense of radiation efficiency.

d. Power input to the antenna. Power output of the NDB transmitter is limited to 50 watts by design. With a short antenna, some of this power is dissipated as heat in the antenna tuning unit. Actual power input to the antenna varies with the capacitive top load and with the length of the vertical radiator.

e. Antenna height above ground. Most NDB antenna installations have the counterpoise at ground level. Increasing the height of the antenna and its associated counterpoise above average ground, by installation on a hilltop, for example, increases the range.

f. Capacitive top load. Increasing the capacitance of the top load with respect to ground raises the antenna current near the top, which increases radiation efficiency. This is especially effective for very short vertical radiators. The capacitance increases directly with the length and number of top elements and inversely with the distance between counterpoise and top load. The top loading of the monopole antenna is an integral part of its design and is not variable.

g. Length of counterpoise radials. Increasing the length of counterpoise radials improves radiation efficiency, up to a length of a quarter wavelength at the operating frequency. Radials of 100 feet (30 m) are used with the balanced-T antenna and 82.5 feet (25 m) are used with the monopole antenna. Space limitations may dictate shorter lengths at some sites. In such cases, extend those radials which are less than the standard length to the boundary of the available space.

h. Number of counterpoise radials. A minimum number of radials for an approximately circular radiation pattern is four. This results in a four-leaf-clover pattern. Increasing the radials to six makes the pattern move nearly circular. More radials result in still better circularity and somewhat better radiation efficiency. The counterpoise for the balanced-T antenna uses 36 radials spaced every 10° and the monopole antenna uses 6 radials spaced at 60° .

i. Soil conductivity. Greater radiation efficiency is realized with higher soil conductivity. The soil acts as an extension of the counterpoise.

j. Termination of radials. Terminating the counterpoise radial wires with 6-foot or longer ground rods at their ends not only keeps them in place but improves the transition between the high conductivity of the metal and the relatively poor conductivity of the soil.

k. Ground impedance. The counterpoise/ground impedance to earth should not exceed 10 ohms; 5 ohms is desired. (This requirement is an exception to SEIP 010.)

1.7.9 Typical Antennas. The EIP engineer may vary the length of the vertical radiator of the balanced-T antenna within the range of 15 feet to 50 feet (5 to 15 m). The BOM for this SEIP results in a length of approximately 30 feet (9 m). Any change in the length of the vertical radiator requires a corresponding change in the lengths of the supporting poles and downlead pole. In selecting the length of the vertical radiator, the engineer must balance the increased range associated with greater lengths against the greater intrusion into the airspace. The monopole antenna is factory-constructed for a specific operating frequency. It can be furnished for any frequency in the 200 to 1500 kHz range. The operating frequency must be added to the BOM when ordering. Except for frequency considerations, the design of the monopole antenna is fixed.

15 November 1979

SEIP 013

1.8 COMMENTS ON PUBLICATION.

1.8.1 Users of this publication are invited to submit recommendations for improvement. Comments should be keyed to the drawing, page, paragraph, and line of the text where change is recommended. A mailing card for convenience is bound with this SEIP. Comments should be sent directly to the Commander, Headquarters, US Army Communications-Electronics Engineering Installation Agency, (HQ, USACEEIA), ATTN: CCC-CED-SEP, Fort Huachuca, Arizona 85613.

1.8.2 Requests for USACEEIA regulations and forms should be addressed to the Commander, USACEEIA, ATTN: CCC-SPT-RM, Fort Huachuca, Arizona 85613.

SECTION 2. SITE SURVEY DATA AND CHECKLIST

2.1 GENERAL. This section provides the information necessary to accomplish the preliminary engineering, equipment layout, and site survey associated with the installation of an NDB facility.

2.2 SITE SELECTION. Site selection for the NDB is a compromise between ideal conditions and practical necessity. Under ideal conditions, the installation would be located on flat terrain devoid of obstructions for several hundred feet from the facility. Since sites are seldom ideal, practical criteria are stated below.

2.3 SITING CRITERIA. The following are the siting criteria for the NDB and are pertinent to obtaining optimum technical performance of the equipment. Unless otherwise specified, measurements are made from the center of the antenna.

a. Wherever possible, a site should be selected close to existing commercial power, signal cables, and established roads.

b. Normally, a flat, clear plot is desirable; however, a hilltop site can also be feasible.

c. The ground should be composed of loamy soil rather than rocks and sand, to make it easier to lay ground wires and provide a good rf ground.

d. The site should be at least 150 feet (45 m) away from any well-traveled, hard-surfaced road.

e. Within 200 feet (61 m) the site should be clear of all reflecting, absorbing, or radiating objects that are over 2 feet (0.6 m) high.

f. Within 400 feet (122 m) the terrain must be clear of all reflecting or radiating objects over 25 feet (8 m) high, such as hills, trees, shrubs, water towers, buildings, and overhead wires and cables (vertical or horizontal).

g. A minimum plot of land 200 feet (61 m) by 240 feet (70 m) is required for a beacon installation using a balanced-T antenna. Where real estate is not a problem, the recommended plot size is 220 feet (67 m) by 300 feet (91 m). This will accommodate a beacon shelter, the antenna and counterpoise, and the access road and turnabout. Antenna orientation is not critical and any orientation may be used. A plot 220 feet (67 m) by 300 feet (91 m) can also accommodate a power building. However, a power building is not included in this SEIP.

h. Where real estate is a problem or it is necessary to remote the antenna and antenna tuning unit from the NDB transmitter, the 40-foot Polestar monopole antenna should be specified. The site for the monopole antenna should be at least 100 feet (30 m) in diameter.

i. Power cabling into the site must be underground within 300 feet (91 m) of the center of the site.

j. Airfield clearance criteria as specified in TM 5-803-4 must be complied with.

2.4 SITE SURVEY CRITERIA. When selecting a site, the first step is to make a preliminary field survey or site survey as required by DCAC 370-160-3. The survey should include an actual field inspection of the entire prospective site area, noting general topographic features, accessibility, availability of power, and obstructions which cannot be removed. The following information must be obtained during the survey:

2.4.1 Coordinates and other adequate identifying means which furnish the geographical location of the site.

2.4.2 Data for preparation of a site drawing shall include the following sketches:

a. A sketch showing the location of the site with respect to any AAF/AHP, airbase, or town in the vicinity, as well as adjacent roads and power and telephone lines.

b. A sketch showing the natural features and other important details of the site, such as plot dimensions, trees, fences, drainage ditches, existing buildings, utility lines, and other obstructions within 1,000 feet (333 m) of the proposed location of the NDB shelter and antenna. This sketch should also show the proposed location of the access road and power line terminal pole together with the routing of the underground and overhead lines running from the terminal pole.

c. A floor plan layout of the control tower cab or other operational area where the remote monitor/receiver is to be installed. Included in this sketch must be power requirements and space requirements for the receiver and antenna, including rf cable routing. The ac power failure indicator should be included, if appropriate.

2.4.3 Climatic conditions, including direction of prevailing wind.

2.4.4 Availability of electrical power.

2.4.5 Availability of civil fire and police protection if the facility is not located on a military installation.

2.4.6 Protection required against vandalism.

2.5 SITE SURVEY CHECKLIST. Prior to conducting the site survey, a checklist will be prepared by the project engineer. The site survey checklist establishes guidelines for the survey team to ensure that all pertinent technical data are identified, assembled, and properly documented. The survey team must also have a complete set of drawings to assist them in the conduct of the survey. Figure 2-1 is a sample site survey checklist for the installation of an NDB facility. The site survey checklist, when completed, will aid in preparing the official survey report.

2.6 SITE SUPPORT REQUIREMENTS. Site support requirements must be thoroughly and precisely identified. These requirements will consist of the following as a minimum:

2.6.1 Specifying the physical location for the NDB site, including the plot size, orientation, and any obstruction clearing required. Where the NDB site creates an airfield clearance violation, specify the requirement for a waiver.

2.6.2 Specify the antenna support poles (balanced-T) or antenna base (monopole), the counterpoise and ground, and footings for shelter. Reference drawing STD-AF-0561. Also specify that the facilities engineer must transport shelter to site, place on footings, and bolt down at time of installation. Obstruction lights and lightning protection are to be provided as part of site support. Obstruction lights should be specified only where the facility creates an obstruction to aircraft flight. (Reference TM 5-803-4.) Not all locations will require obstruction lights.

2.6.3 Specify the power required to the shelter and any restrictions on power routing.

2.6.4 Specify any security fencing required.

2.6.5 Specify the space required for the remote monitor receiver, including antenna, and specify the space required for the ac power failure indicator receiver if one is to be installed.

2.6.6 Specify any installation team support and material storage and handling requirements.

2.6.7 Specify that crystals for the NDB transmitter must be provided. State NDB frequency.

2.7 EQUIPMENT CHARACTERISTICS. The physical and electrical characteristics of the major components of the NDB facility are listed in table 2-1.

Table 2-1. Equipment Characteristics

Nomenclature	Height	Dimensions Width	Depth	Weight (lbs)	Input power	Power consumption
NDB transmitting set type FA 9782	26.5" (67 cm)	12" (30 cm)	11.5" (29 cm)	90	120/240 V ac 50/60 Hz or 48 V dc	160 VA or 128 W
Antenna tuning unit type FA 9782/1 (Note 4)	27.4" (70 cm)	23.3" (59 cm)	13.8" (35 cm)	40	Derives power from transmitter	Included in trans- mitter figures
Transmitter changeover unit type NAX-9 (Note 5)	11.5" (29 cm)	8" (20 cm)	4" (10 cm)	9	Derives power from transmitter	Included in trans- mitter figures
Monopole Antenna PA 40 A (Note 6)	40' (12 m)	N/A	N/A	600	120/240 V ac	
Shelter ES810-8	111" (282 cm)	96" (244 cm)	120" (305 cm)	2,000	120/240 V ac 50/60 Hz	3,000 W max (Note 1)
Rectifier-charger A-46	17.125" (43 cm)	12.188" (31 cm)	10" (25 cm)	57	120/240 V ac 50/60 Hz	1,200 W max
Battery, 80 Ah (Note 2)	8.75" (23 cm)	12.5" (32 cm)	6.75" (17 cm)	25	From rectifier- charger	Included in rec- tifier-charger figures

Table 2-1. Equipment Characteristics (Continued)

NOTES:

1. Shelter includes electric lights, convenience outlets, and thermostatically controlled ventilating fan and louvers. Dimensions are exterior.
2. Four batteries are required.
3. No environmental controls are required other than those included with the shelter.
4. Not required when using monopole antenna.
5. Not required for single transmitter.
6. Includes antenna tuning unit. If obstruction lights are required order PA 40 AL. Operating frequency must be specified when ordering the monopole antenna. The monopole antenna will be specified where the antenna must be located remotely from the transmitter or where space is limited.

15 November 1979

SEIP 013

SITE SURVEY CHECKLIST

1. PROJECT TITLE AND NUMBER: _____

2. SITE NAME: _____

3. LAT: _____ LONG: _____ ELEV: _____ FT MSL

4. PURPOSE OF SITE SURVEY: _____

5. PERSONNEL CONTACTED:

<u>Name and Grade or Rank</u>	<u>Position and Organization</u>	<u>Phone No.</u>
_____	_____	_____
_____	_____	_____
_____	_____	_____
_____	_____	_____
_____	_____	_____
_____	_____	_____
_____	_____	_____

Figure 2-1. Sample Site Survey Checklist (sheet 1 of 9)

6. CLIMATIC DATA:

(Climatic data having bearing on engineering of project: strong winds, icing, extremely high or extremely low temperature, persistent high humidity, lightning. Include prevailing wind.)

7. LOCATION SKETCH:

(Provide a sketch showing the location of the site with respect to any AAF/AHP, airbase, or town in the vicinity, as well as adjacent roads and power and telephone lines.)

Figure 2-1. Sample Site Survey Checklist (sheet 2 of 9)

15 November 1979

SEIP 013

8. AIRFIELD CLEARANCE:

(Provide sketch showing distance of site from runway centerline, distance of site from taxiways, and other pertinent items. Is waiver required?)

Figure 2 i. Sample Site Survey Checklist (sheet 3 of 9)

9. NDB TRANSMITTER SITE:

a. Sketch. (Provide a sketch showing the natural features and other important details of the site, such as plot dimensions, trees, fences, drainage ditches, existing buildings, utility lines, and other obstructions within 1,000 feet (333 m) of the proposed location of the NDB shelter and antenna. This sketch should also show the proposed location of the access road and power line terminal pole together with the routing of the underground and overhead lines running from the terminal pole.)

Figure 2-1. Sample Site Survey Checklist (sheet 4 of 9).

b. Discussion. (Location of antenna support poles, antenna, counterpoise/ground, transmitter, antenna tuning unit, transmitter changeover unit, rectifier-charger, ac power failure indicator. Include sketches as required.)

c. Ac Power Availability.

d. Ground.

1. Resistance to ground of existing counterpoise: _____ ohms.

Date measured: _____ . Method: _____ .

2. Soil resistivity: _____ ohm-centimeters.

Date measured: _____ . Method: _____ .

3. Soil type: _____ .

Figure 2-1. Sample Site Survey Checklist (sheet 5 of 9).

10. MONITOR RECEIVER SITE:

- a. Sketch. Provide a floor plan layout of the control tower cab or other operational area where the remote monitor/receiver is to be installed. Include space for the receiver and antenna, rf cable routing, and the ac power failure indicator, if appropriate.

Figure 2-1. Sample Site Survey Checklist (sheet 6 of 9).

15 November 1979

SEIP 013

b. Discussion.

c. Ac power.

11. COMMUNICATIONS CABLE:

a. Existing cable

1. From: _____ To: _____

2. Cable number: _____ Pairs available: _____

3. AWG No.: _____ Pairs needed: _____

b. New cable requirements: _____

c. Leased line requirements: _____

Figure 2-1. Sample Site Survey Checklist (sheet 7 of 9).

12. PHOTOGRAPHS:

a. Title: _____

1. Source: _____

2. Date: _____

3. Shows: _____

b. Title: _____

1. Source: _____

2. Date: _____

3. Shows: _____

c. Title: _____

1. Source: _____

2. Date: _____

3. Shows: _____

d. Title: _____

1. Source: _____

2. Date: _____

3. Shows: _____

(Add additional sheets if necessary.)

Figure 2-1. Sample Site Survey Checklist (sheet 8 of 9).

15 November 1979

SEIP 013

13. SPECIAL PROBLEMS:

- a. EMI: _____
- b. Obstructions: _____
- c. Equipment interface: _____
- d. Other: _____

14. MISCELLANEOUS:

(Any additional information which bears on the engineering and installation of the facility. Include availability of civil fire and police protection if facility is not located on military installation. Include any special protection required against vandalism.)

DATE

SITE SURVEY TEAM CHIEF

Figure 2-1. Sample Site Survey Checklist (sheet 9 of 9).

SECTION 3. INSTALLATION SPECIFICATIONS AND INSTRUCTIONS

3.1 INTRODUCTION. This section provides installation specifications and guidance for the installation of an NDB facility.

3.2 GENERAL INSTRUCTIONS.

3.2.1 Adherence to Policies and Documents.

a. The equipment shall be installed in accordance with established policies, the engineering drawings and instructions, and referenced drawings and publications deemed necessary by the responsible engineering activity. Minor deviations from the EIP or SEIP may be made by the installation supervisor without prior approval by the project engineer. A minor change is one that does not--

- (1) Alter the specified floor plan or major item of equipment
- (2) Violate a mandatory standard
- (3) Alter the intended operational capability or procedures
- (4) Alter the intent or end result of the required testing.

A major change is one which does alter or violate specifications listed in 1 through 4 above. The installation team shall not make major changes to the requirements and instructions contained in this specification without the prior approval of the project engineer. Requests for an approval of major changes may be made by telephone; however, a follow-up message or letter is required. All changes shall be documented (redlined) by the team chief and the document which authorized the change shall be included in the documentation. Two sets of redlined documents are required. One set shall be left on site.

b. Installation personnel must be familiar with applicable technical order AFTO 31-10 series, Standard Installation Practices, to ensure that the facility is installed in accordance with standard practices.

c. Prior to start of installation, all team members should review the safety instructions in CCR-385-1 and in the installation and operating instruction manuals furnished by the equipment manufacturers.

3.2.2 Changes in Scope. The installation team shall not accomplish work requested by local post, camp, or station personnel unless such work is covered by the EIP or other agreements.

3.2.3 General Installation Precautions. The installation team chief will ensure that all safety regulations and proper accident prevention regulations are observed by all members of his team during all phases of installation. He must contact the responsible accident clinic prior to start of work to ensure quick medical treatment in case of emergency. To help prevent injuries to personnel and damage to equipment, the following safety regulations should be observed.

a. Installation personnel should be trained in safety practices pertinent to their duties and in the application of emergency first aid, rescue, resuscitation, and closed-chest heart massage.

b. Approved insulated tools, in good condition, should be used for electrical work. Tools with friction- or rubber-tape-covered handles should be avoided.

c. With the exception of test equipment, metallic measuring rules or metal-cased objects should not be used near energized electrical circuits. Personnel shall not wear metallic objects such as rings, identification tags, medals, wrist watches, or bracelets while working on or near electrical equipment.

3.3 INSTALLATION INSTRUCTIONS. The procedures required to install the NDB facility must be accomplished in a definite order. This will ensure that all work is completed as represented on the installation drawings and that all specifications are adhered to. Minor changes to the installation sequence may be made in consideration of manpower, time, equipment, material, and safety. The following steps are recommended:

3.3.1 Preinstallation steps. Prior to starting installation, the following must be accomplished:

3.3.1.1 Coordinate installation tasks with the operating agencies and/or other cognizant organizations. This will include clearance to proceed, logistics, review of support requirements, and request of any other support necessary for the completion of tasks.

15 November 1979

SEIP 013

3.3.1.2 Verify that all support requirements are complete or will be completed in time to prevent delays.

3.3.1.3 Brief team members on particular hazards that may be encountered. Emphasize safety by reviewing safety procedures and practices.

3.3.1.4 Inventory the BOM items to ensure all items are on hand. Missing items or shortages must be noted prior to the arrival of the installation team onsite.

3.3.1.5 Arrange for the transportation of personnel and equipment; determine the methods for control and storage of BOM items, tools, and other required equipment.

3.3.1.6 Review all specifications and drawings to ensure that no additional engineering assistance is required prior to the start of installation.

3.3.1.7 Coordinate all outages that may be required for the installation and/or cutover of this facility with the ATC chief and the airfield commander.

3.3.2 Antenna Installation. Refer to drawing STD-AF-0561 for the balanced-T or STD-AF-0564 for the monopole antenna. Installation of the antenna support poles, centerpole, base for the monopole, and counterpoise are site support items and should have already been installed. Install the antenna in accordance with one of the above drawings.

3.3.3 Shelter Installation. Refer to drawing STD-AF-0561 for shelter location and footing requirements. Footings should have been provided as site support items. It will be necessary to have the facilities engineer transport shelter to site, place on footings, and bolt down.

3.3.4 Shelter Equipment Support. Refer to drawing STD-AF-0563. Install Unistrut on shelter wall for the support of electronic equipment and conduit in accordance with this drawing. For single beacon facility, modify Unistrut and conduit requirements in the EIP.

3.3.5 Power Lines. Have facilities engineer terminate ac power lines to circuit breaker panel in the shelter.

3.3.6 Electronic Equipment Installation. Install beacon transmitters, changeover unit, antenna tuning unit, rectifier-charger, and battery bank in accordance with drawing STD-AF-0562. Where only a single beacon facility is to be installed, omit the changeover unit and second transmitter in the EIP.

3.3.7 Equipment and Power Wiring. Install all required internal ac and dc power wiring, interconnecting equipment wiring, and rf coaxial cabling in accordance with STD-AF-0565. Install the ac and dc conductors in the conduit previously installed.

3.3.8 Grounding. Install the ground box and wiring in accordance with STD-AF-0561.

3.3.9 Remote Monitor/Alarm Receiver. Refer to drawing STD-AF-0562 for monitor receiver and antenna details. The preferred mounting location is in the NAVAIDS console. Installation will be in accordance with the EIP drawings.

3.3.10 Ac Power Failure Indicator. Refer to drawing STD-AF-0566. Landline transmission of power failure indication requires an indicator unit, which is normally mounted near the monitor/alarm receiver. The NAVAIDS console is the preferred location.

SECTION 4. ENGINEERING INSTALLATION DRAWINGS

4.1 GENERAL. This SEIP contains the engineering installation drawings necessary for the installation of an NDB facility. The SEIP drawings should be modified and supplemented to fit a particular site by the responsible engineering agency in accordance with CCCR-34-2. The following drawings are included as part of this SEIP:

STD-AF-0561	Nondirectional Beacon Balanced-T Antenna and Ground Installation Details (5 sheets)
STD-AF-0562	Nondirectional Beacon Shelter and Tower Floor Plan Layout (2 sheets)
STD-AF-0563	Nondirectional Beacon Shelter Conduit and Unistrut Installation (2 sheets)
STD-AF-0564	Nondirectional Beacon Monopole Antenna and Counterpoise Installation Details (2 sheets)
STD-AF-0565	Nondirectional Beacon Ac and Dc Power Distribution and Interconnect Diagrams (2 sheets)
STD-AF-0566	Nondirectional Beacon Ac Power Failure Indicator (2 sheets)

4.2 MODIFICATION OF INSTALLATION DRAWINGS. The engineering drawings may be modified during and after the installation of a project to reflect changes. Drawing changes will be marked with colored pencils as follows: red for additions, blue for engineering notes, and yellow for deletions. Copies of modified drawings should be retained at each site and should also be forwarded to the responsible area office of the C-E engineers for corrective action.

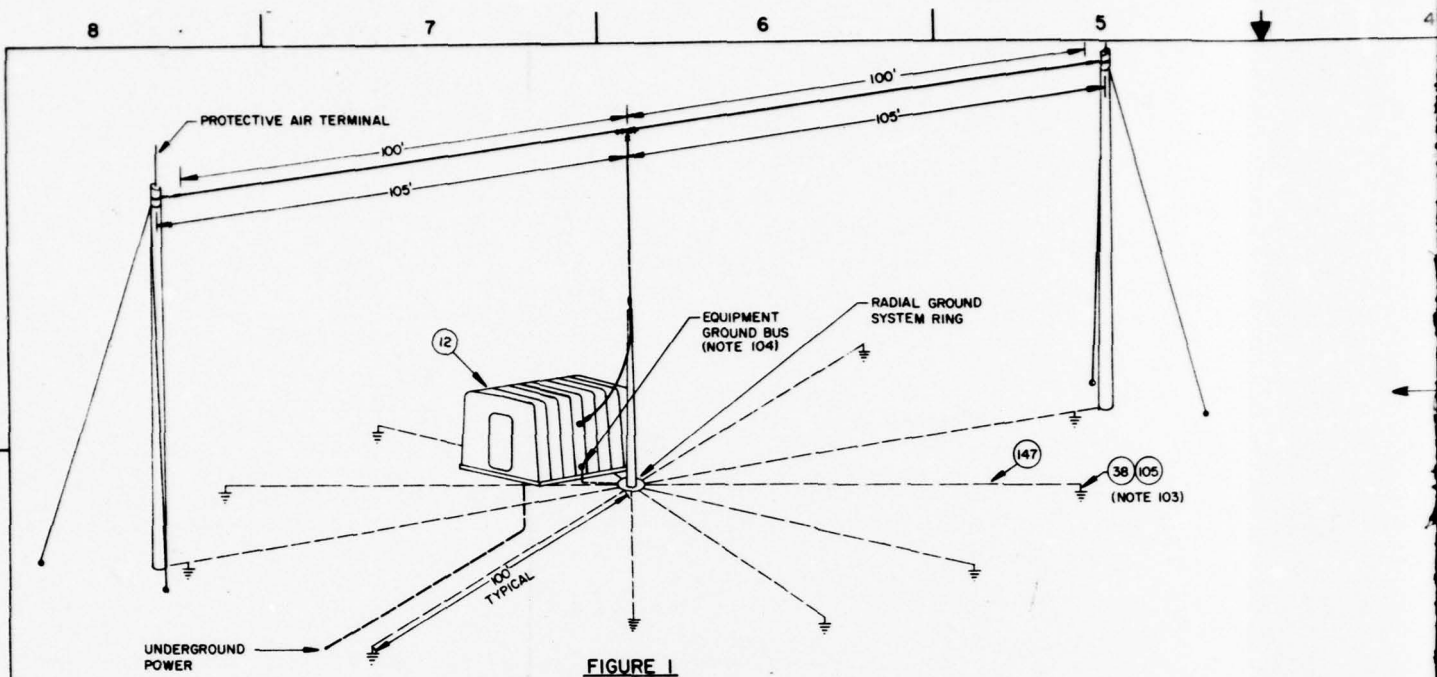

FIGURE 1
TYPICAL ANTENNA & GROUND USED WITH
NONDIRECTIONAL BEACON

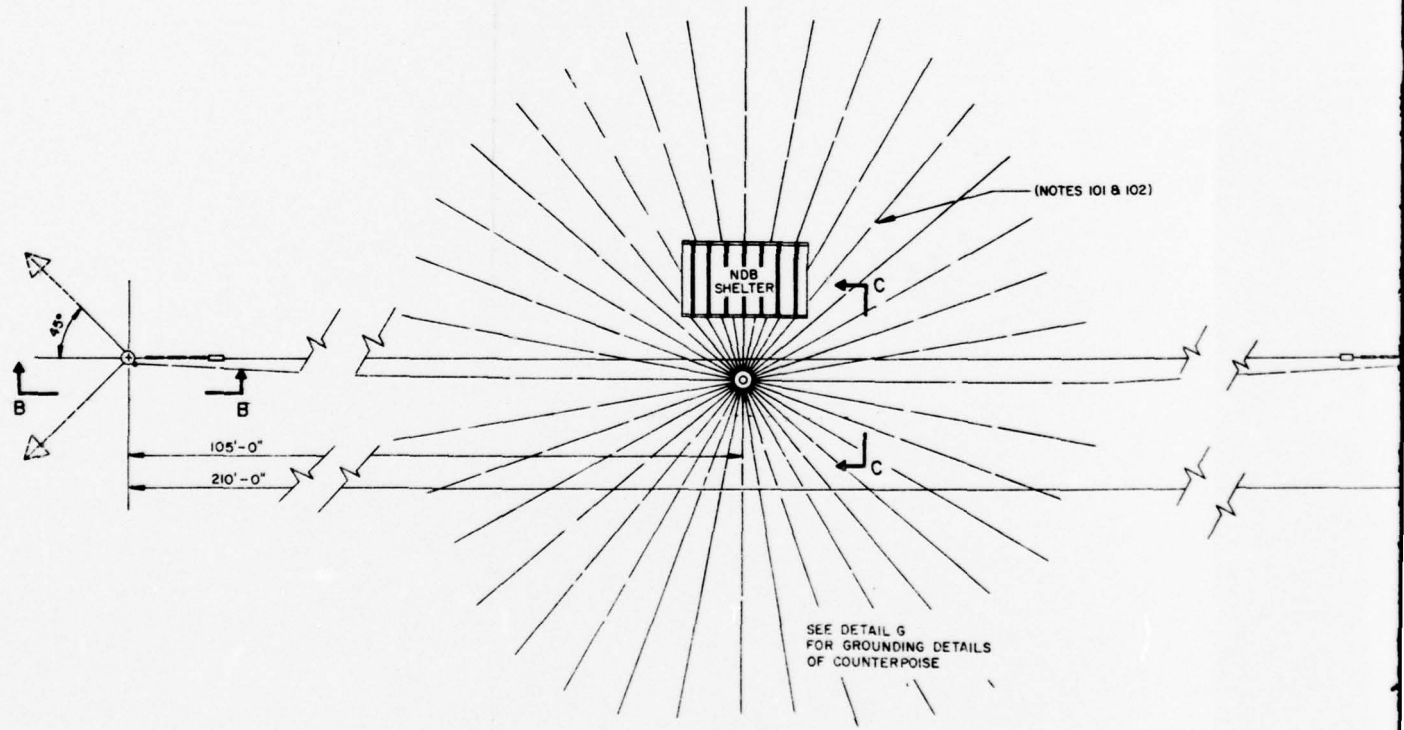
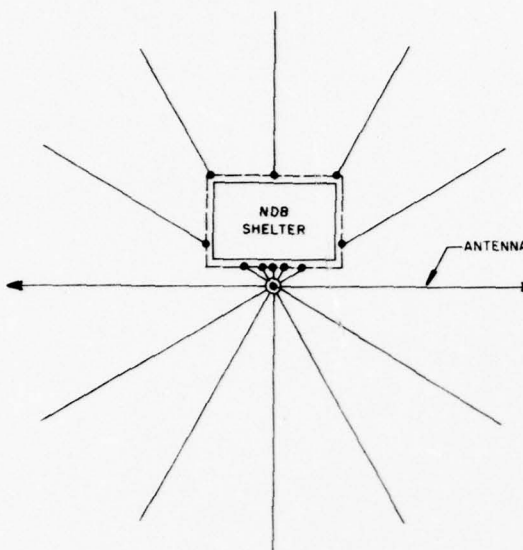

FIGURE 2
ANTENNA COUNTERPOISE SYSTEM LAYOUT



DETAIL A
ALTERNATE ANTENNA & GROUND SYSTEM
 (NOTE 102)

REVISION				
ZONE	REV	DESCRIPTION	DATE	APPROVED

- NOTES:
101. INSTALL 36 RADIALS 10 DEGREES APART EXTENDING 100' OR TO THE EDGE OF THE PROPERTY, WHICHEVER IS CLOSER. IF SECURITY FENCE IS METALLIC, CONNECT RADIALS TO FENCE USING #6 AWG CONDUCTOR FROM GROUND ROD.
 102. A SYMMETRICAL GROUND SYSTEM IS PREFERRED. THE RADIAL ARRANGEMENT SHOWN IN DETAIL A IS ACCEPTABLE IF GROUND SYSTEM IS PLACED AFTER BUILDING FOUNDATION IS INSTALLED.
 103. TERMINATE EACH GROUND RADIAL USING A GROUND ROD AND CLAMP. SILVER SOLDER EACH CONNECTION AFTER CLAMPING.
 104. GROUND IMPEDANCE SHALL NOT EXCEED 10 OHMS; 5 OHMS DESIRED.

105	24957N	ROD, GROUND, 5/8" X 8', WITH CLAMP	5975-00-296-5324	EA	
104	11883C	ROD, ANCHOR, OVAL EYE TYPE 5/8" X 77" LG	4030-00-243-8344	EA	
98	25114A	POLE, LINE CONSTRUCTION, WOOD, 20 FT	5510-00-983-8811	EA	
97	00796D	POLE, LINE CONSTRUCTION, WOOD, 45 FT	5510-00-161-2760	EA	
94	25253L	PLATE, COPPER, 6' X 4" X 1/4"	9535-00-167-1964	FT	
92	25106D	PHOTO CELL, REMOTE, CROUSE HINDS D560	NSNR	EA	
87	03010M	OUTLET, CONDUIT, SINGLE GANG, C-H FDC-3	5975-00-867-7474	EA	
83	07483Q	NUT, PLAIN, HEX, 5/8"-11	5310-00-915-4891	EA	
82	16883K	NUT, PLAIN, HEX, 1/2"-13	5310-00-616-2793	EA	
80	00558H	NUT, HEX, 1/4 X 20, STEEL, CAD PLTD	5310-00-285-1650	HD	
78	10675E	NUT, PLAIN, HEX #8-32 BRASS	5310-00-934-9762	HD	
76	25108F	NIPPLE, 1" X 2" LG, THD BOTH ENDS	4730-00-196-2072	EA	
67	11054J	LIGHT, MARKER, C-H KL6198/AM-2547-4	6210-00-299-4608	EA	
66	11055Z	LENS, LIGHT, RED, FRESNEL FACE	6210-00-283-9738	EA	
65	22663C	LAMP, INCANDESCENT 100 WATTS	6240-00-538-8891	EA	
63	10012B	KIT, STRAPPING AND SEALING	5340-00-640-3996	EA	
61	02288Z	INSULATOR, STRAIN, 12" X 1-1/2" MD X 1" THK	5970-00-892-3643	EA	
60	02262M	INSULATOR, STRAIN, 3-1/4" LG X 2-5/8" W X 2-5/8" THK	5970-00-356-0574	EA	
59	02234A	INSULATOR, STAND OFF CYL SHAPE, 10" L X 1-1/4 DIA	5970-00-198-9809	EA	
58	0267A	INSULATOR, FEED THRU BOWL TYPE, 4-5/8" DIA	5970-00-405-8791	EA	
57	02497Z	HOLDER, POLE STEP, 1/4" X 4"	5975-00-263-1082	EA	
56	10557H	GROMMET, RUBBER 3/4" OD X 9/16" ID	5325-00-276-6229	EA	
55	07490K	GROMMET, RUBBER 1-3/8" OD X 3/4" ID	5325-00-276-5954	EA	
52	00010J	FLUX, SOLDERING, NON-CORROSIVE PASTE	3439-00-260-1264	CN	
47	02353J	COUPLING, CONDUIT, RIGID 1"	5975-00-152-1130	EA	
45	02444B	CONDUIT, METAL, RIGID, 1" THICKWALL, 10' LG	5975-00-228-0040	LG	
41	00063L	CLIP, WIRE ROPE, 1/4" DIA	4030-00-293-9968	EA	
39	07727E	CLAMP, CABLE, 0.250" ID, NYLON	5340-00-308-3210	EA	
38	22737A	CLAMP, ELECTRICAL, 2-10 AWG WIRE, 1/2" ROD	5975-00-186-3976	EA	
37	02391P	CLAMP, ELECTRICAL, 2 TO 8 AWG WIRE, 5/8" RD	5999-00-186-2912	EA	
36	06265N	CLAMP, SHORT BAIL, 0.3125" DIA STRAND	5975-00-319-0949	EA	
35	14163N	CLAMP, CONDUIT, 1", APPLETON P/N 17152	NSNR	EA	
25	10180Y	BOX, JUNCTION, 12 X 12 X 4, PN-121248	5975-01-019-0468	EA	
21	19544L	BOLT, MACH, HEX HD 1/4" - 20 X 7/8" LG	5306-00-834-3939	HD	
18	00441A	BOLT, ANGLE, EYE, 5/8" - 11 X 12" LG	5306-00-546-6809	EA	
17	00408B	BOLT, EYE, 1/2" - 13 X 10.5" LG	5306-00-407-6405	EA	
15	00047C	ANCHOR, GUY, 8" DIA, 135 SQ IN OPEN	4030-00-188-0535	EA	
12	25119F	SHELTER, EQUIPMENT 9'3" H X 8' W X 10' L, GRASSIS CORP. ES8111-B	NSNR	EA	

LIST OF MATERIALS

DEPT NO: **STD-AF-0561**
 SHEET 1 OF 5

ORGANIZATION: **U.S. ARMY COMMUNICATIONS-ELECTRONICS ENGINEERING INSTALLATION AGENCY**

DESIGN BY: **J. COTHMAN** DATE: **JUN 79**
 DRAWN BY: **J. A. BODIE** DATE: **JUN 79**
 CHECKED BY: **F. MYERS** DATE: **JUN 79**

NONDIRECTIONAL BEACON ANTENNA AND GROUND SYSTEM

APPROVAL: *[Signature]* ACTIVITY: **CEL-ED-NSA** SIZE: **D** FSC# NO: **50470** DRAWING NO:
 PROJECT: **11012** SCALE: **NONE** SHEET OF

(105)
 TE 103)

(102)

2

11012

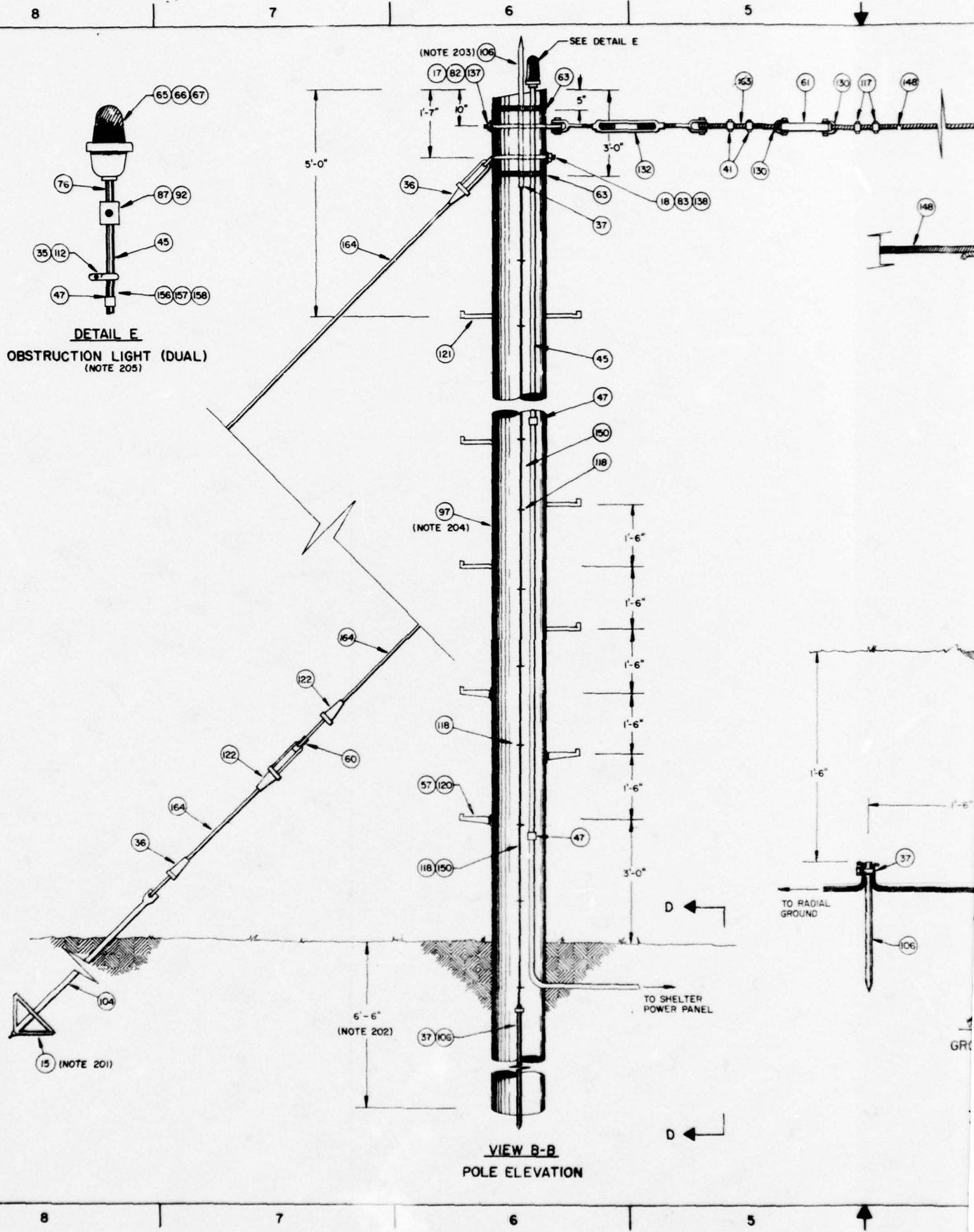

DETAIL E
OBSTRUCTION LIGHT (DUAL)
 (NOTE 205)

VIEW B-B
POLE ELEVATION

DRAWING NO. 21 20067

4

3

2

1

REVISION			
ZONE	REV	DESCRIPTION	DATE

NOTES:

201. ANCHORS PROVIDED ARE FOR AVERAGE FIRM SOIL. ANCHOR REQUIREMENTS FOR SPECIAL SOIL CONDITIONS SHOULD BE DETERMINED LOCALLY.
202. POLE DEPTH SHOWN IS STANDARD IN AVERAGE FIRM SOIL. IF OTHER SOIL CONDITIONS ARE ENCOUNTERED, POLE DEPTH SHOULD BE DETERMINED LOCALLY.
203. AIR TERMINALS ARE TO EXTEND A MINIMUM OF 2' ABOVE OBSTRUCTION LIGHTS.
204. WHERE VERTICAL DOWNLEAD LENGTHS OF MORE THAN 30' ARE REQUIRED, POLES OF GREATER HEIGHT MUST BE SPECIFIED.
205. INSTALL OBSTRUCTION LIGHTS ONLY WHERE REQUIRED BY TM 5-803-4, CHAPTER 8.

D

C

B

A

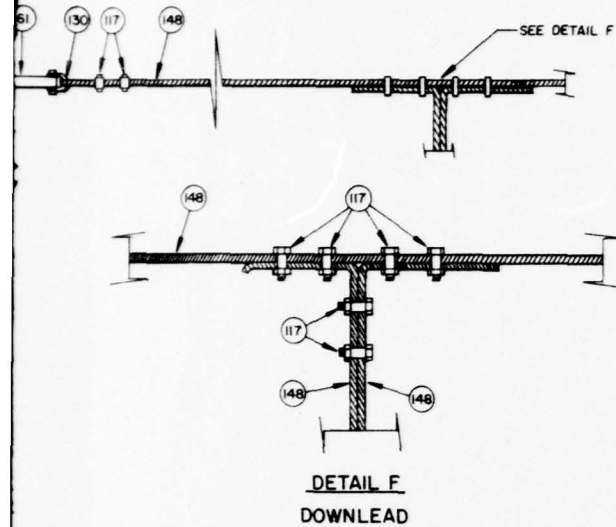

DETAIL F
DOWNLEAD

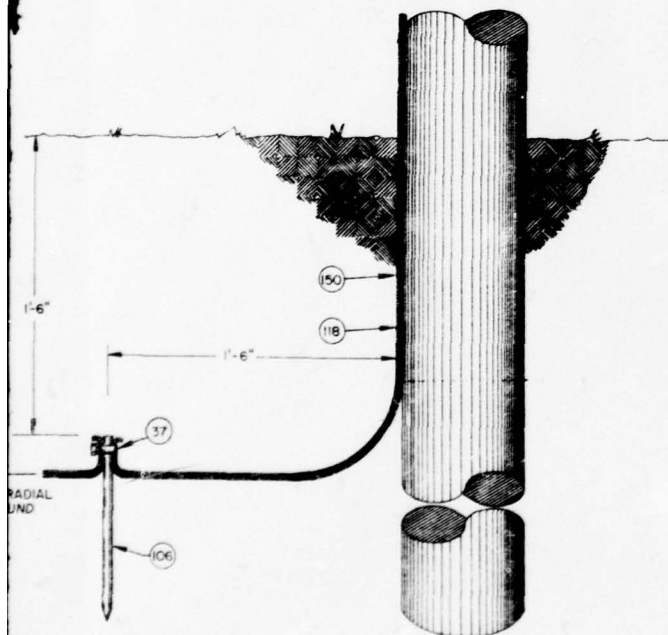

VIEW D-D
GROUND ROD

164	00023A	WIRE, STRAND, STL, 5/16" DIA, 1000' RL	4010-00-221-2708	RL	
163	000260	WIRE, STRAND, 1/4" GALVS	4010-00-222-5344	FT	
158	195252	WIRE, ELEC, 14 AWG, GRN STRANDED	6145-00-043-1255	FT	
157	074610	WIRE, ELEC, 14 AWG, WHITE STRANDED	6145-00-052-3278	FT	
156	035056	WIRE, ELEC, 14 AWG, BLK STRANDED	6145-00-184-5341	FT	
155	09004N	WIRE, ELEC, 12 AWG, YELLOW, STRANDED, TW	NSNR	FT	
152	09009Z	WIRE, ELEC, 8 AWG, YELLOW, STRANDED, TW	NSNR	FT	
151	21653E	WIRE, ELEC, 4 AWG, YELLOW, STRANDED, TW	NSNR	FT	
150	03369C	WIRE, ELEC, BARE 6 AWG (GROUND), SOLID	6145-00-128-8685	FT	
149	14677C	WIRE, COPPER BARE, 2 AWG, SOLID	6145-00-229-9832	FT	
148	03425D	WIRE, BARE, 6 AWG, 7 STRAND	6145-00-160-7148	FT	
147	03380Q	WIRE, BARE, 6 AWG, SOLID SOFT COPPER	6145-00-129-9320	LB	
142	16703E	WASHER, LOCK INT & EXT TEETH #8	5310-00-905-5159	HD	
141	25252M	WASHER, LOCK INT & EXT TEETH 1/4"	5310-00-889-2528	HD	
138	14454Z	WASHER, FLAT, SQUARE, .687 ID, 2" OD, STL	5310-00-371-2649	EA	
137	00516Z	WASHER, FLAT, ROUND, .561 ID, .974" OD	5310-00-198-3642	EA	
136	10290Y	WASHER, FLAT, RD, STL, 0.266" ID X 0.50" OD	5310-00-819-4698	EA	
134	167929	WASHER, FLAT, RD BRASS #8	5310-00-264-1389	HD	
132	144566	TURNBUCKLE, ASSY, BODY STL 11.312" X 19.5"	5340-00-188-0339	EA	
130	00088Z	THIMBLE, ROPE, STL, 3/8" DIA	4030-00-498-8071	EA	
128	08647A	TERMINAL LUG, SOLDER TYPE, F/#12 AWG	5940-00-159-1292	PG	
126	07452Y	TERMINAL LUG, 2-B AWG, 1/4"	5940-00-549-8075	EA	
122	07580X	STRANDWISE, LONG BAIL, 5/16" DIA	5975-00-539-0947	EA	
121	02500C	STEP, POLE, HOT GALVS, 5/8" X 10"	5975-00-280-3105	EA	
120	02469F	STEP, POLE, DETACHABLE, 5-1/2"	5975-00-407-6554	EA	
119	16917Z	STEEL, BAR, COLD ROLLED, 1-1/4" X 3/8"	9510-00-596-2029	FT	
118	00600F	STAPLE, FENCE 1/4" X 1-1/2" LG	5315-00-151-9856	LB	
117	14455A	SPLICE CONNECTOR, SPLIT BOLT TYPE F/4 AWG	5940-00-865-7528	PG	
115	00002B	SOLDER, 50/50 BAR FORM, LEAD TIN ALLOY	3439-00-163-4347	LB	
112	15321K	SCREW, WOOD, 12 X 1, ROUND HEAD	5305-00-901-2502	GR	
111	09109A	SCREW, WOOD, RHB, 8 X 3/4 ROUND HEAD	5305-00-904-0262	GR	
109	16796J	SCREW, WOOD, PAN HEAD, #8 - 32 X 3/4" LG	5305-00-206-1285	HD	
106	02394M	ROD, GND, 5/8" X 5', COPPER PLATED	5975-00-187-5292	EA	

ITEM	SML	DESCRIPTION	NSN	UI	QTY
LIST OF MATERIALS CONT'D					
IDENT NO: STD-AF-0561					
SHEET 2 OF 5					
DRAWN BY: JOHN A BODIE					
SCALE: NONE ENT'D IN: UNAPPROVED SHEET OF: 4100-F3					

4

3

2

1

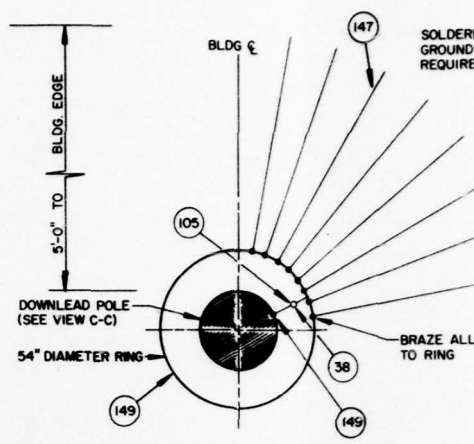
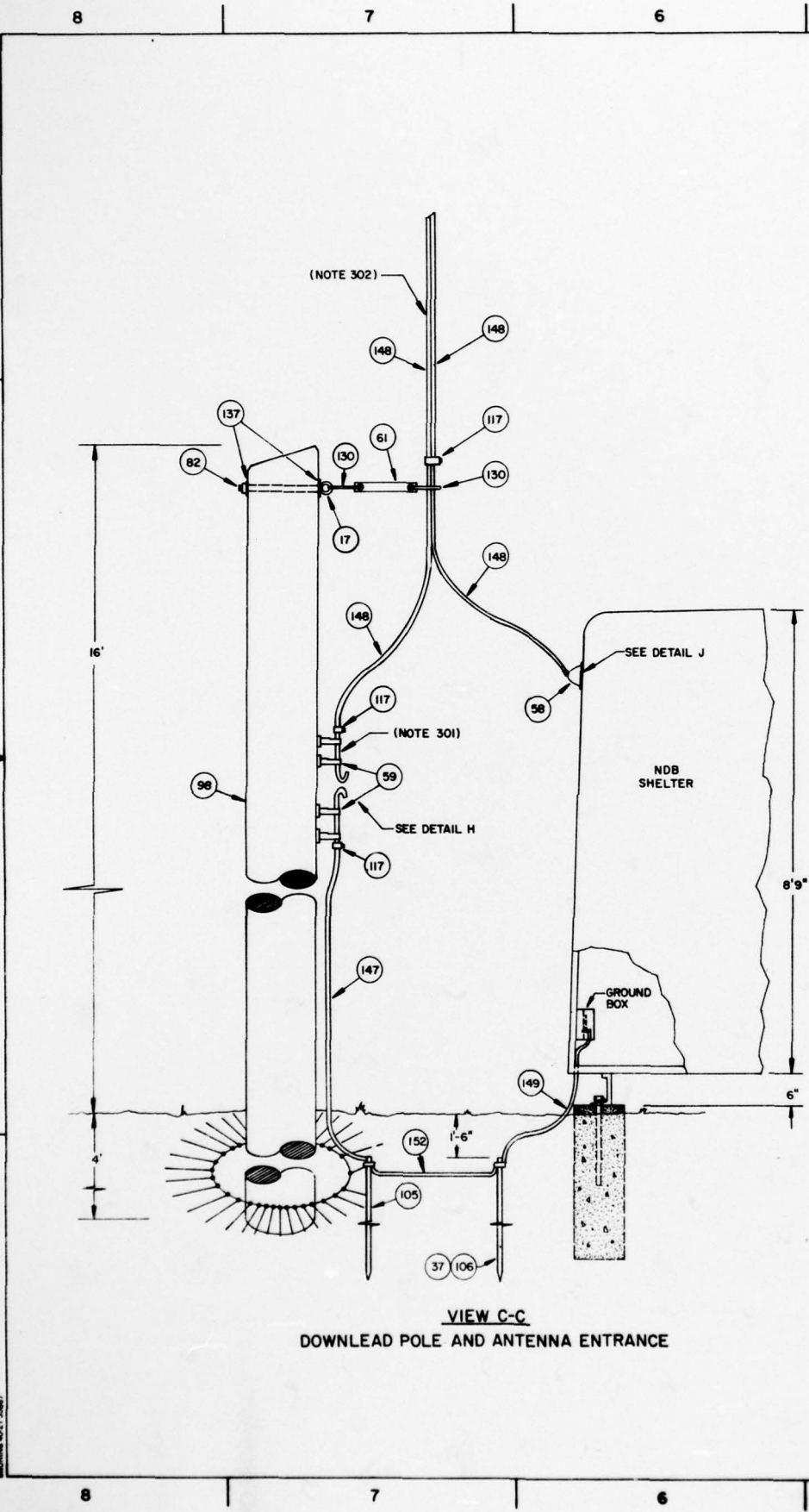

DETAIL G
COUNTERPOISE GROUNDING DETAILS

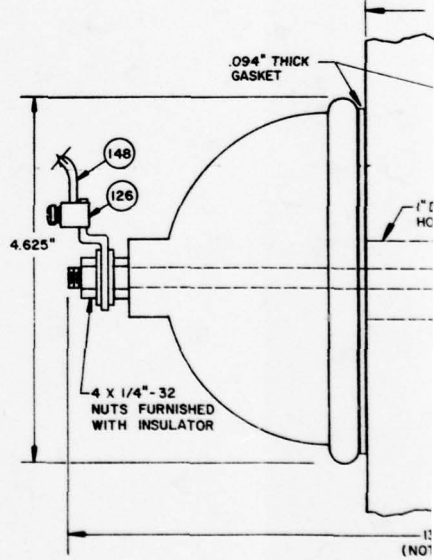

ANTENNA

DRAWING 40-31 3567

4

3

2

1

REVISION				
ZONE	REV	DESCRIPTION	DATE	APPROVED

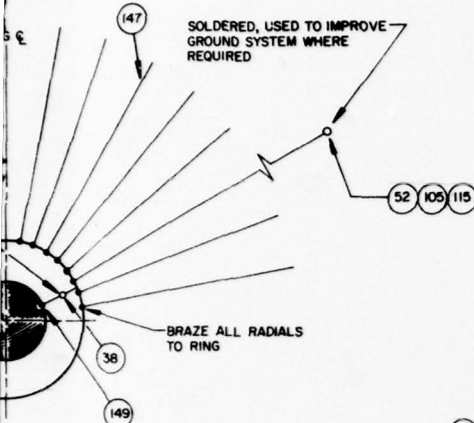

NOTES:

- 301. HORN GAP SPACING VARIES WITH INDIVIDUAL INSTALLATION AND POWER USED. TO ADJUST, REDUCE GAP WHERE IT JUST FLASHES WITH HEAVY MODULATION AND THEN DOUBLE THE SPACING FOR NORMAL OPERATION. APPROXIMATE SPACING 1/8" TO 3/8".
- 302. THE VERTICAL DOWNLEAD SHALL BE BETWEEN 15 AND 50 FEET LONG. THE LENGTH TO BE DETERMINED BY THE OPERATIONAL RANGE REQUIREMENTS OF EACH BEACON FACILITY.
- 303. CUT 1/4-INCH CENTER ROD TO REQUIRED LENGTH.

TAIL G
ROUNDING DETAILS

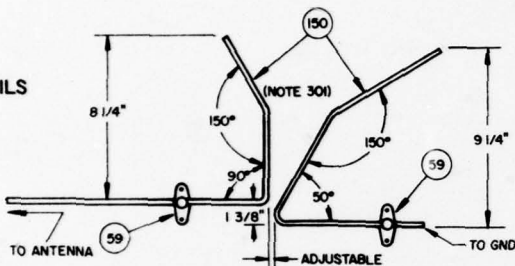

DETAIL H
HORN GAP

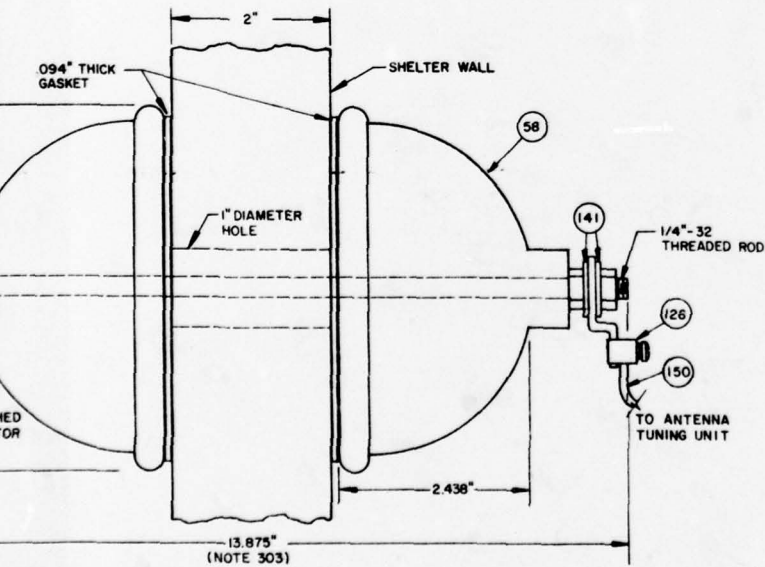

DETAIL J
ANTENNA FEEDTHROUGH

IDENT NO	STD-AF-0561	SIZE	FORM NO	DRAWING NO
	SHEET 3 OF 5	D	50470	
DRAWN BY	JOHN A. BODIE	SCALE	NONE	REGISTERED IN USACSEA EDR
SHEET 3 OF 5				

2

CI-05-F2 1

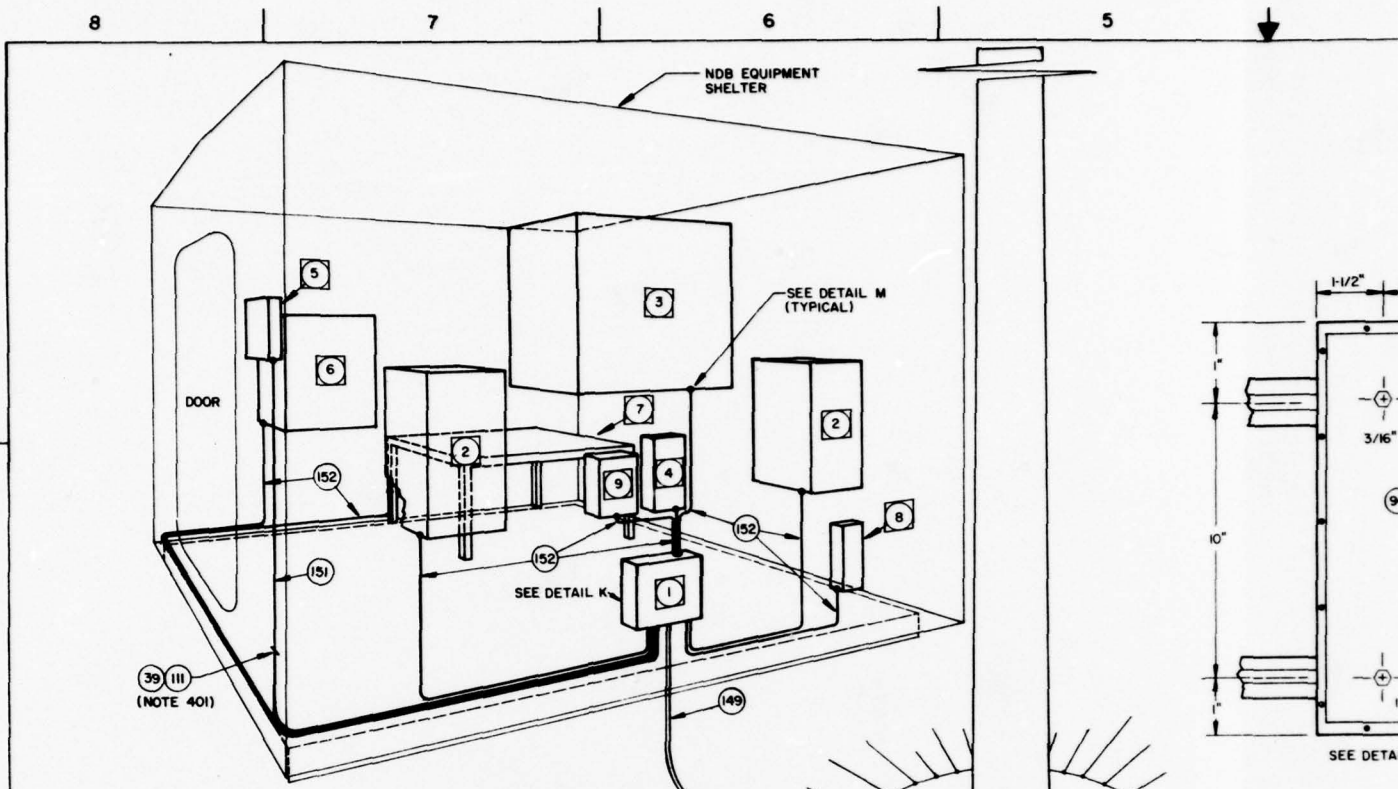
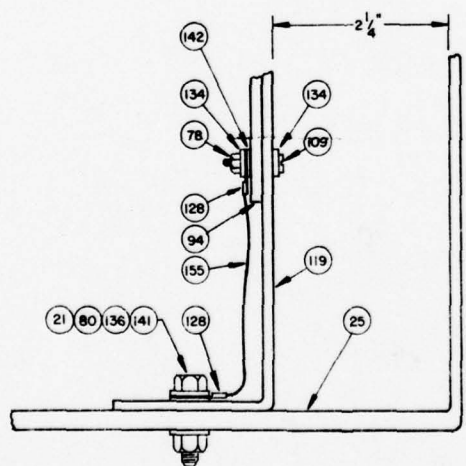

FIGURE 3
EQUIPMENT GROUNDING DETAILS



DETAIL L
GROUND PLATE/SUPPORT BAR
MOUNTING DETAILS

DRAWING NO. 11 2067

(149) (151) OR (152)

TERM
T

4

3

2

1

REVISION				
ZONE	REV	DESCRIPTION	DATE	APPROVED

LEGEND:

- ① GROUND BOX
- ② NDB TRANSMITTER
- ③ ANTENNA TUNING UNIT
- ④ TRANSMITTER CHANGEOVER UNIT
- ⑤ AC POWER PANEL
- ⑥ RECTIFIER-CHARGER
- ⑦ WORK BENCH
- ⑧ SIGNAL CABLE ENTRANCE BOX
- ⑨ AC POWER FAILURE TRANSMITTER

NOTES:

- 401. ROUTE GROUND WIRES ALONG SHELTER WALLS NEAR FLOOR LEVEL AS SHOWN IN FIGURE 3. ATTACH TO SHELTER WALL RIBS, WHICH ARE SPACED ON 18" CENTERS, USING ITEMS SHOWN.
- 402. REFER TO STD-AF-0563, SHEET 2, FOR GROUND BOX TO UNISTRUT MOUNTING DETAILS.

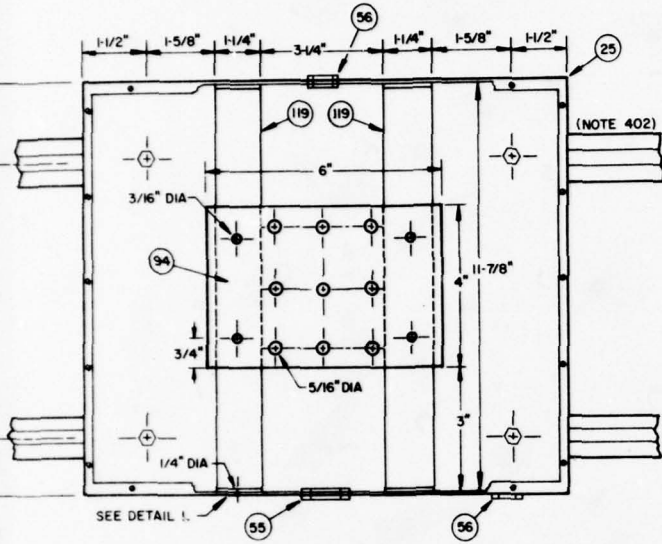

DETAIL K
GROUND BOX ASSEMBLY

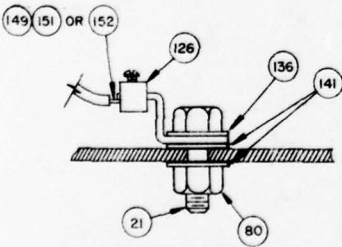

DETAIL M
TERMINAL LUG ATTACHMENT
TO GROUND PLATE OR
EQUIPMENT CABINET

IDENT NO STD-AF-0561	SIZE D	PSUM NO 50470	DRAWING NO.
DRAWN BY JOHN A. BOOIE	SCALE NONE	DATE	SHEET OF

2

CT 05 F 2

4

3

2

1

D

C

B

A

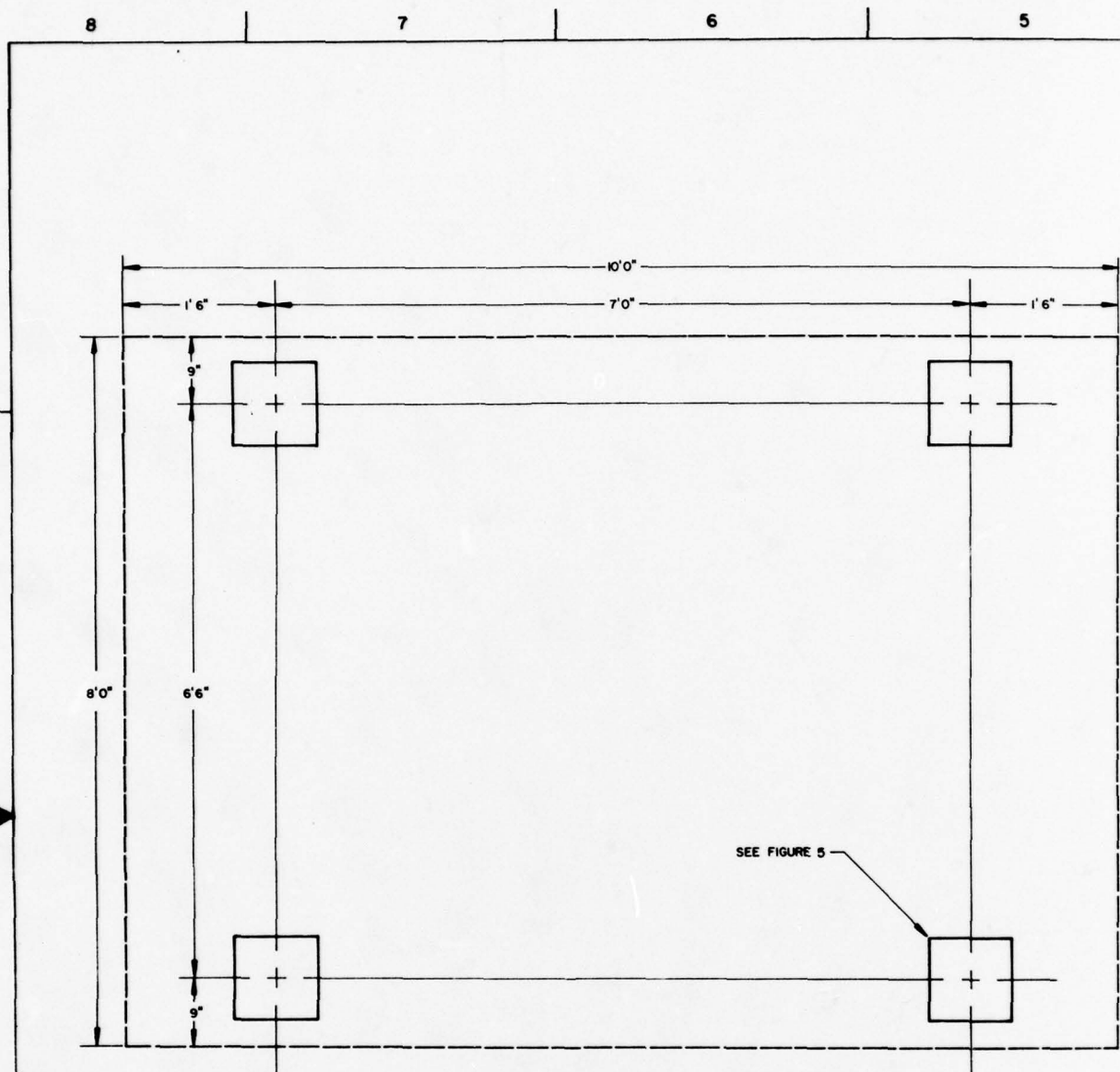
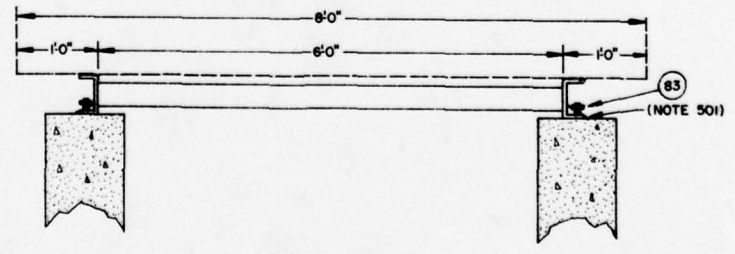
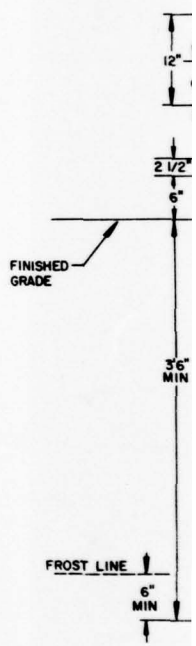

FIGURE 4
SHELTER FOUNDATION DETAILS



DETAIL N
SHELTER TIE DOWN

DRAWING 40-21 2007

4

3

2

1

REVISION			
ZONE	REV	DESCRIPTION	DATE

NOTES:

- 501. THE FOUR 5" X 5" X 1/4" SHELTER TIEDOWN PLATES ARE FURNISHED WITH THE ADB SHELTER.
- 502. THE SHELTER CONCRETE FOUNDATIONS SHALL HAVE A MINIMUM 28 DAY COMPRESSIVE STRENGTH OF 3000 PSI, 5" SLUMP.
- 503. THE SHELTER CONCRETE FOUNDATIONS SHALL BE A MINIMUM OF 3'6" BELOW FINISHED GRADE AND 6" BELOW FROST LINE.
- 504. THE SHELTER CONCRETE FOUNDATIONS SHALL BE CURED LEVEL AND TOP OF EACH PIER STEEL TROMELED.

D

C

B

A

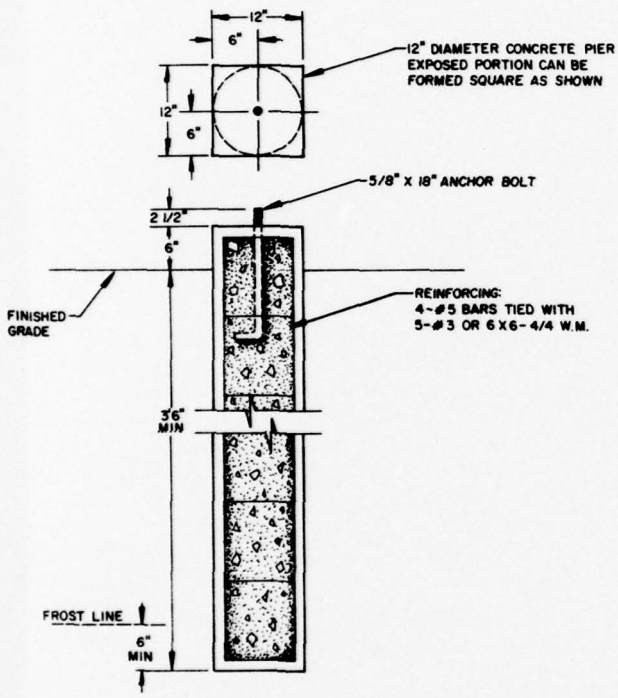

FIGURE 5
SHELTER PIER DETAILS
 (NOTES 502, 503 & 504)

2

IDENT NO. STD-AF-0561	SIZE PSCW NO. D 50470	DRAWING NO.
DRAWN BY JOHN A. BODIE	SCALE NONE	CHECKED BY 01-15-F2
APPROVED		

4

3

2

1

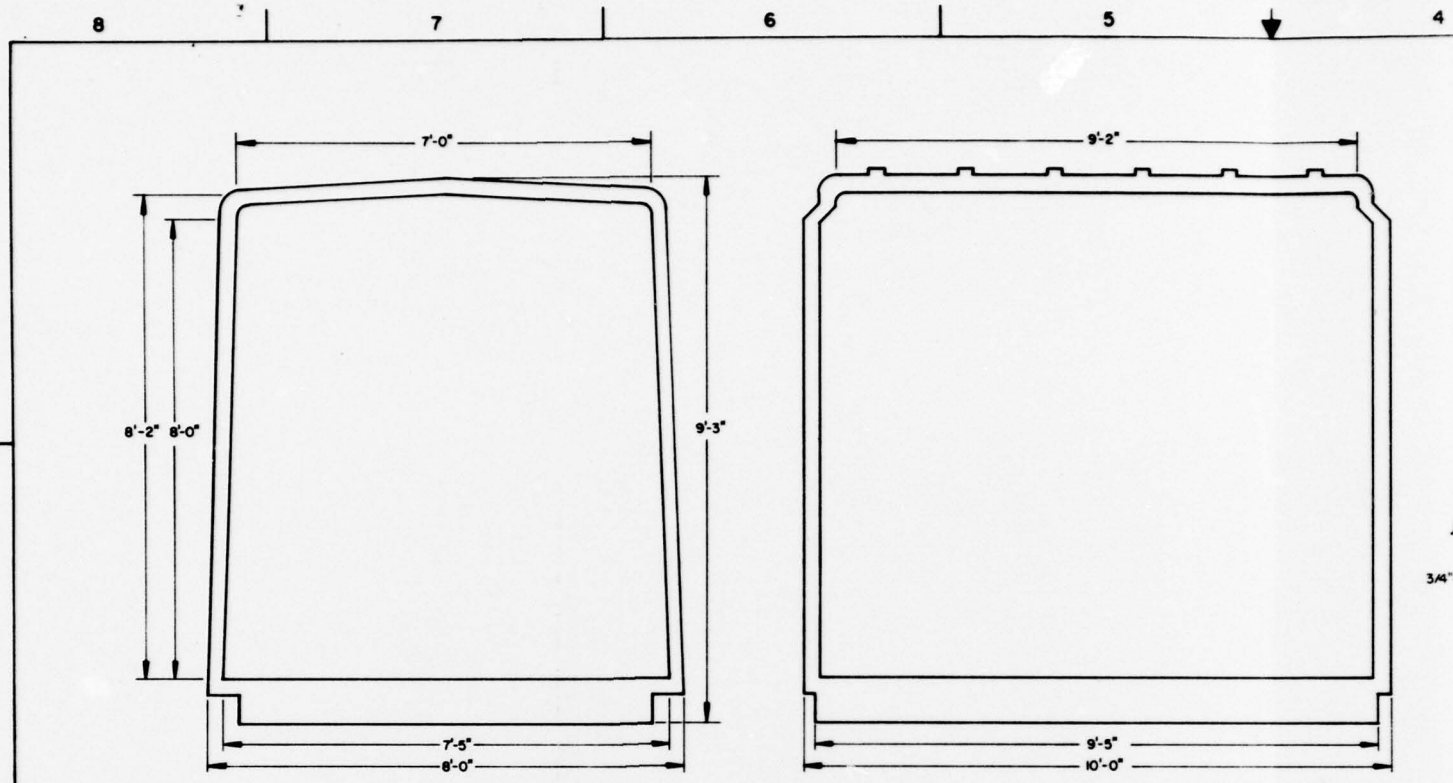

FIGURE 1
SHELTER LAYOUT
 (NOTES 106 & 107)

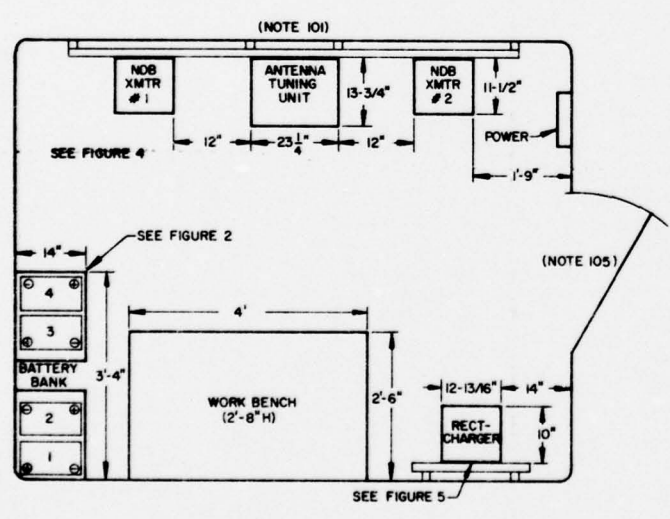

FIGURE 3
NDB SHELTER FLOOR PLAN LAYOUT

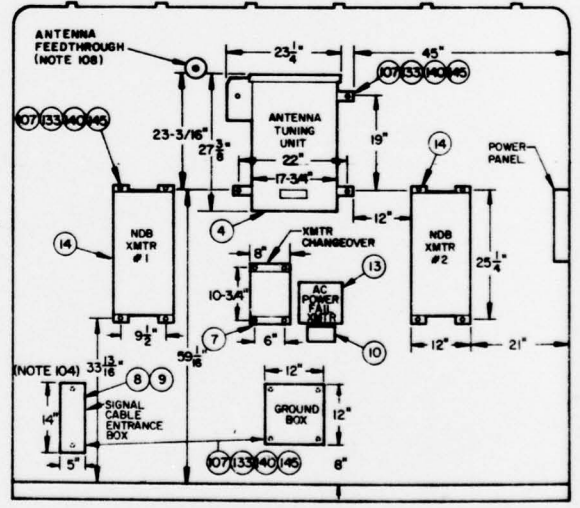

FIGURE 4
NDB EQUIPMENT MOUNTING DETAILS

4 3 2 1

REVISION				
ZONE	REV	DESCRIPTION	DATE	APPROVED

NOTES:

101. EQUIPMENT IS SUPPORTED ON UNISTRUT ATTACHED TO THE SHELTER RIBS. REFER TO DRAWING STD-AF-0563 FOR INSTALLATION DETAILS.
102. REFER TO MANUFACTURER'S MANUAL FOR BEACON TRANSMITTER, CHARGE-OVER UNIT, AND ANTENNA TUNING UNIT DETAILS.
103. INSTALL BATTERIES IN ACID-RESISTANT TRAY.
104. SIGNAL CABLE ENTRANCE BOX WITH PROTECTORS REQUIRED AT SITES WITH OUTSIDE PLANT CABLES.
105. ENTRANCE DOOR IS 2'-8" WIDE AND 6' HIGH.
106. STRUCTURAL DESIGN LOADINGS ARE 90 PSF FOR THE ROOF AND 200 PSF FOR THE FLOOR.
107. NOMINAL DOOR, WALL, AND ROOF THICKNESS IS 2". NOMINAL FLOOR THICKNESS IS 3". REINFORCED RIBS ARE 3-1/2" THICK.
108. LOCATION OF ACCESS HOLE FOR CABLE FEEDTHROUGH IS SHOWN ON STD-AF-0563, SHEET 2 OF 2, DETAIL F.

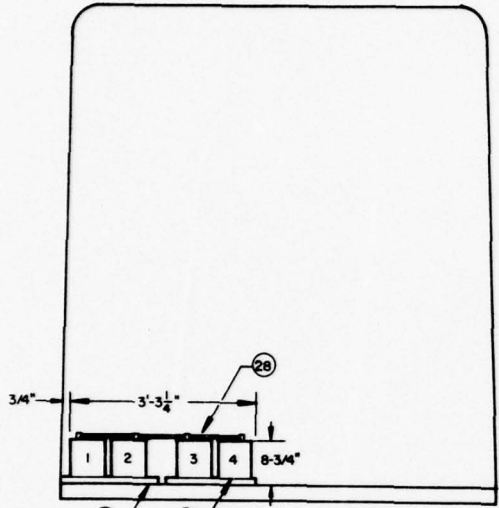

FIGURE 2
BATTERY BANK MOUNTING DETAILS

146	00521D	WASHER, LOCK, .312 ID, .394 OD, ZINC PLTD	5310-00-190-3746	EA	
145	00569H	WASHER, LOCK .310 ID, .506 OD, CADMIUM PLTD	5310-00-407-9566	HD	
140	09139K	WASHER, FLAT, .320 ID, .8594" OD, CADMIUM PLTD	5310-00-639-1526	EA	
133	25257A	UNISTRUT SPRING NUTS, 5/16, PH - P1007	5310-00-806-5908	EA	
131	25110L	TRAY, BATTERY OR SERVICE, 14" X 18" X 7/8" ACID RESISTANT, GREEN, GSA	7350-00-780-0095	EA	
114	00704A	SHIELD, EXPANSION, ANCHOR, 1/4" X 1-1/2"	5340-00-961-7308	HD	
111	09109A	SCREW, WOOD, RWB, 8 X 3/4 ROUND HEAD, PHILLIPS TYPE	5305-00-904-0262	GR	
107	25254K	SCREW, HEX HEAD, CAP 5/16 X 1-1/4	5305-00-225-9081	EA	
103	02421A	RING, BRIDLE, 1-5/8" EYE SIZE, 1-1/4" X 1/4" SHANK, STEEL, GALVANIZED, 10 PER PACKAGE	5975-00-223-1862	PG	
93	08401L	PLATE, STEEL, 5" X 0.1875"	9515-00-204-3967	FT	
91	02406H	PANEL, BLANK, 19" X 7" X 1/8", GREY	5975-00-685-9791	EA	
90	08712Z	PANEL, BLANK, 19" X 3-1/2" X 1/8", GREY	5975-00-686-2541	EA	
89	23067Z	PANEL, BLANK, 19" X 1-3/4" X 1/8", GREY	5975-00-671-9061	EA	
88	19746A	PANEL SCREW, GREY, 10-32 X 3/4 IN LG, PHILLIPS DRIVE	NSNR	HD	
81	07679A	NUT, HEX, 5/16"-18	5310-00-880-7744	HD	
42	08400H	COMPOUND, SEALING, SERIESOLID	9030-00-275-6115	PT	
39	07727E	CLAMP, CABLE, 0.250" ID, NYLON	5340-00-980-3210	EA	
33	08677K	CABLE TIE, 3-1/2 IN MAX, BLACK, NYLON, 0.301" W X 13.38" L, RANGE 0.108" TO 3.5"	5975-00-985-0630	HD	
30	03623D	CABLE, RG 50C/U 50 OHM, COAX, 21 AWG	6145-00-542-8092	FT	
28	25237C	CABLE, BATTERY, 1 GAGE, 12" LONG, BELDEN P/N 71241	NSNR	EA	
23	08866Z	BOLT, U, RD 5/16 - 18 X 2.688" LG W/NUTS	5305-00-809-1360	EA	
14	25121L	TRANSMITTER, NONDIRECTIONAL BEACON, 50-WATT, SOLID STATE, 190-553 KHZ, NAUTEL FA 9782	NSNR	EA	
11		RECEIVER, MONITOR ALARM, LF/HF, 200 TO 535 KHZ	NSNR	EA	
7	25120M	BEACON TRANSMITTER CHANGEOVER UNIT, NAUTEL MAX-9	NSNR	EA	
6	25116C	BATTERY CHARGER, 120/240 V AC SINGLE PHASE INPUT, 10 AMPERE 48V OUTPUT, EQUIPPED WITH AC CIRCUIT BREAKER AND AC POWER FAILURE RELAY, LAMARCHE A-46-10-68V	NSNR	EA	
5	25115B	BATTERY, MAINTENANCE FREE, 80 AH, 12-1/2" X 6-3/4" X 8-3/4", GDUOL MF-27F	NSNR	EA	
4	25122K	ANTENNA, TUNING UNIT, NAUTEL FA 9782/1	NSNR	EA	
3		ANTENNA, MWIP, NDB MONITOR RECEIVER	NSNR	EA	
ITEM	SML	DESCRIPTION	NSN	UI	QTY

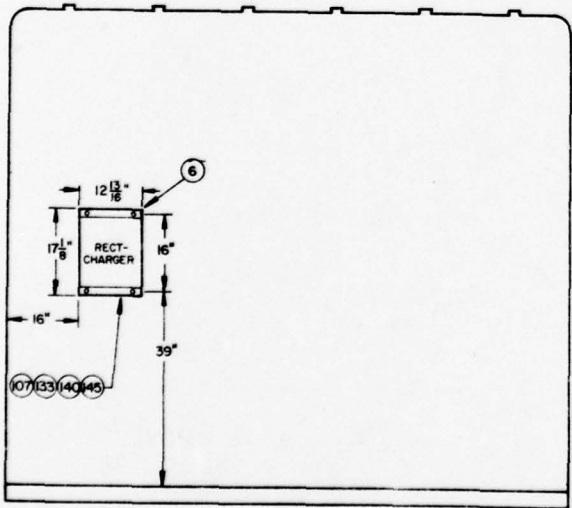

FIGURE 5
RECTIFIER-CHARGER MOUNTING DETAILS

LIST OF MATERIALS

IDENT NO: **STD-AF-0562** SHEET 1 OF 2

ORGANIZATION: **US ARMY COMMUNICATIONS-ELECTRONICS ENGINEERING INSTALLATION AGENCY**

DESIGN BY: **J COCHRAN** DATE: **JUL 79**

DRAWN BY: **JOHN A BODIE** DATE: **JUL 79**

CHECKED BY: **F MYERS** DATE: **JUL 79**

NONDIRECTIONAL BEACON FLOOR PLAN AND EQUIPMENT LAYOUT

APPROVAL: [Signature] ACTIVITY: **CEL-CAD-SEA** SIZE: **D** FSC# NO: **50470** DRAWING NO.

SCALE: **NONE** SHEET: **1** OF **1**

4 3 2 1

01-05-12 1

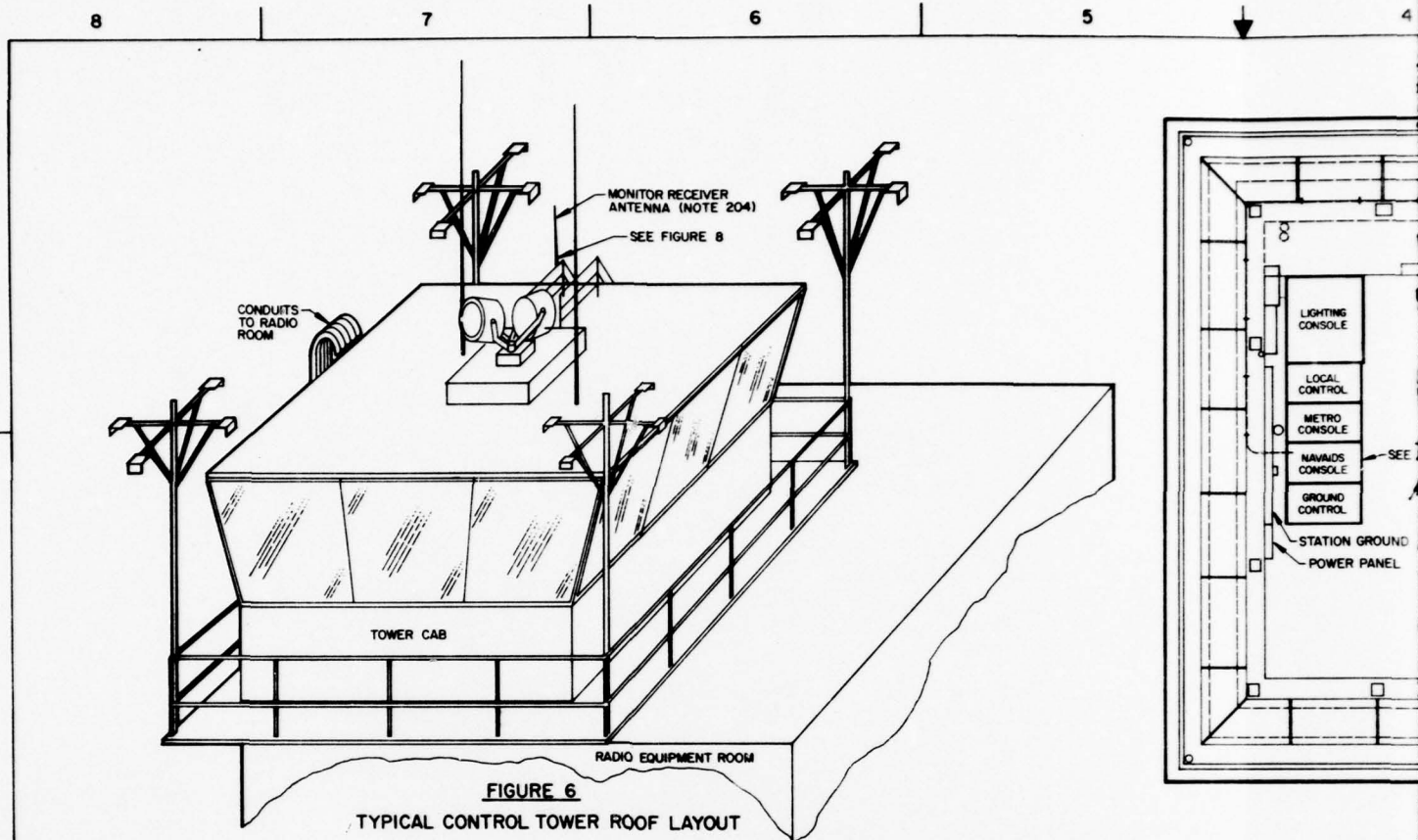

FIGURE 6
TYPICAL CONTROL TOWER ROOF LAYOUT

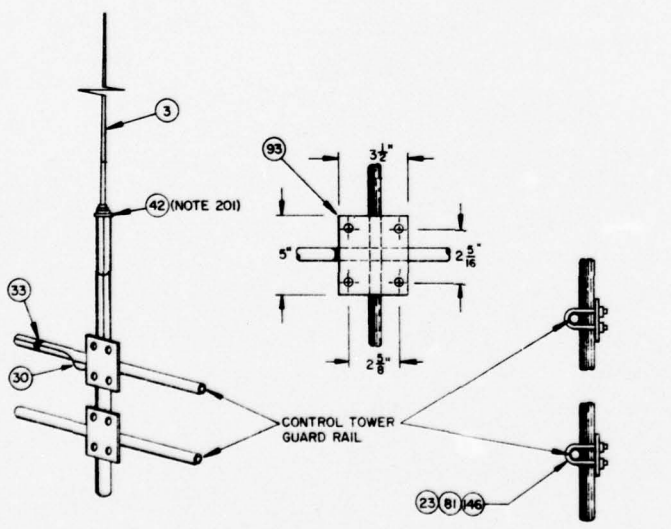

FIGURE 8
TYPICAL ANTENNA MOUNTING ON CONTROL TOWER GUARD RAIL

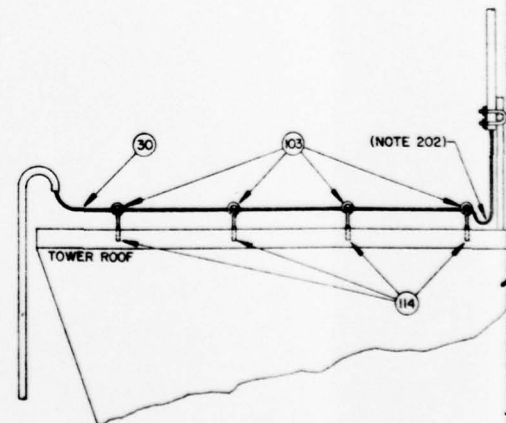

FIGURE 9
RF CABLE SUPPORT

DRAWING 62-1 20487

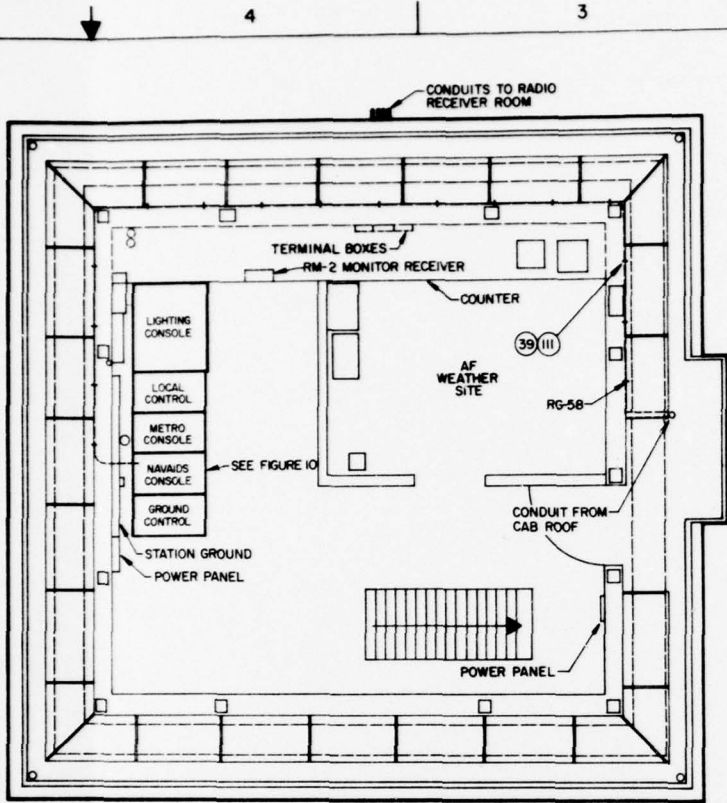

FIGURE 7
TYPICAL CONTROL TOWER FLOOR PLAN

REVISION			
ZONE	REV	DESCRIPTION	DATE

- NOTES:
- WEATHERPROOF ANTENNA RF CONNECTION WITH SEALANT COMPOUND.
 - INSTALL DRIP LOOP IN RF CABLE NEAR ANTENNA CONNECTION.
 - INSTALL AC POWER FAILURE RECEIVER IN THIS LOCATION WHEN LANDLINE CABLE PAIRS EXIST BETWEEN TOWER CAB AND MOB SHELTER. REFER TO STD-AF-0566 FOR ASSEMBLY DETAILS.
 - MOUNT MONITOR RECEIVER ANTENNA ON OUTSIDE OF TOWER GUARD RAIL.

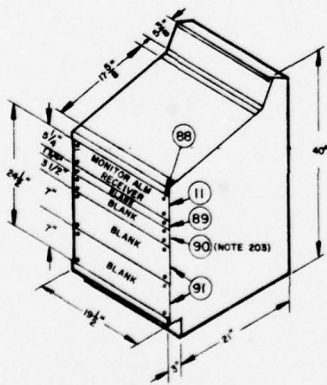

FIGURE 10
NAVAIDS CONSOLE

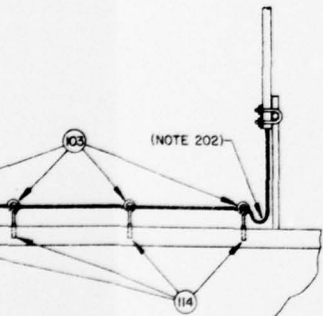

FIGURE 9
CABLE SUPPORT

2

IDENT NO. STD-AF-0562	SIZE D	FORM NO. 50470	DRAWING NO.
DRAWN BY JOHN A. BOGIE	SCALE NONE	DATE 11/12	SHEET 1
APPROVED			

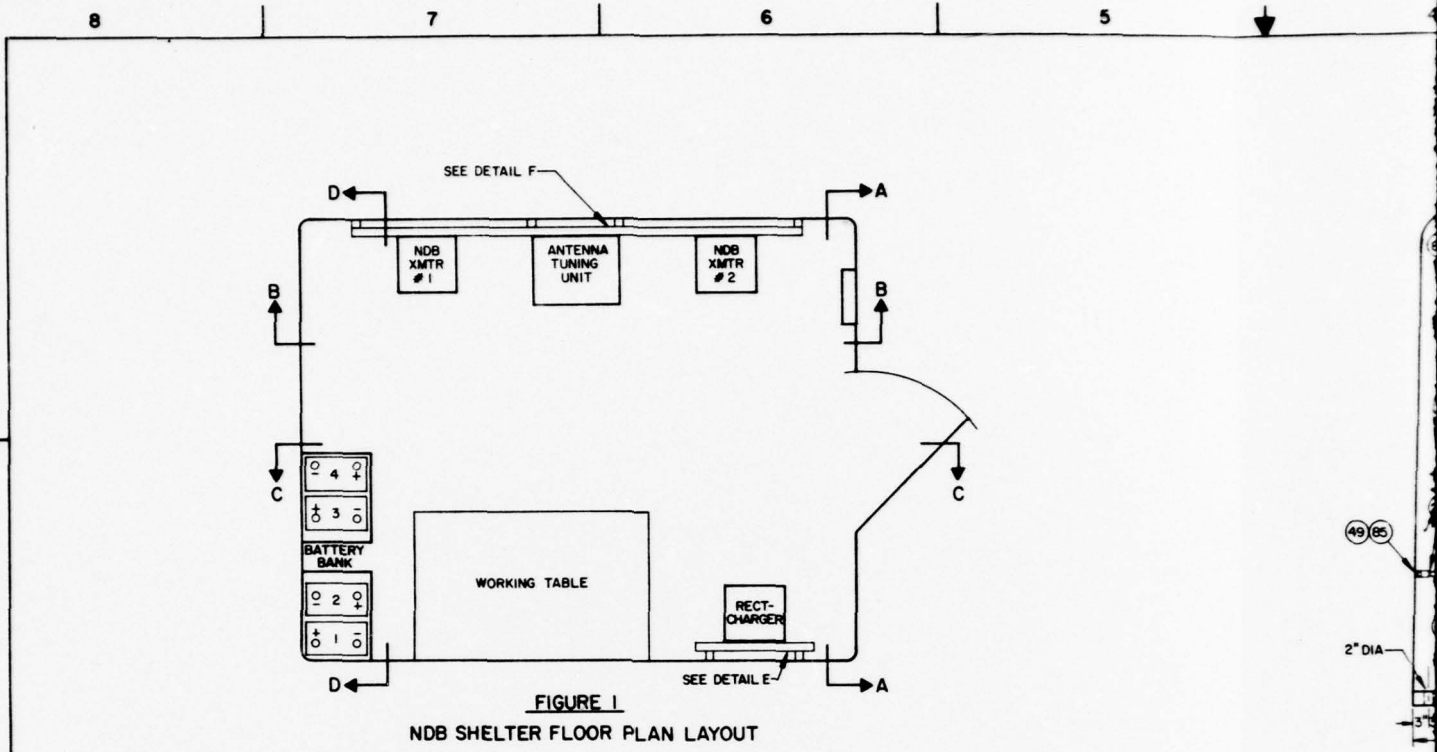
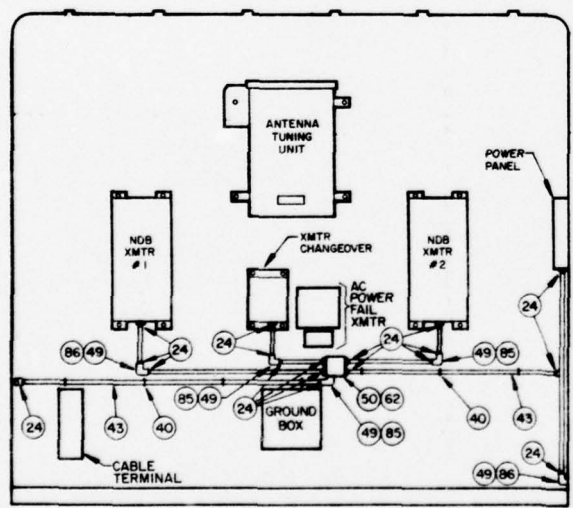
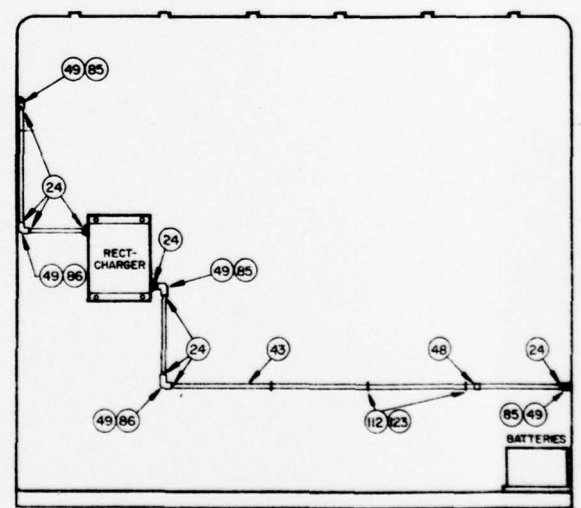

FIGURE 1
NDB SHELTER FLOOR PLAN LAYOUT



VIEW B-B
NDB EQUIPMENT CONDUIT INSTALLATION



VIEW C-C
RECTIFIER-CHARGER CONDUIT INSTALLATION

49/85
2" DIA
3"

4

3

2

REVISION			
ZONE	REV	DESCRIPTION	DATE

NOTES:

- 101. USING ITEMS SHOWN, ANCHOR CONDUIT TO SHELTER WALL RIBS, WHICH ARE SPACED ON 18" CENTERS.
- 102. ANCHOR CONDUIT TO UNISTRUT, WHERE INSTALLED, WITH ITEM 40.
- 103. CABLE ENTRY HOLES ARE PROVIDED BY MANUFACTURER. CENTER OF HOLES IN FLOOR IS 1-1/2" FROM WALL.

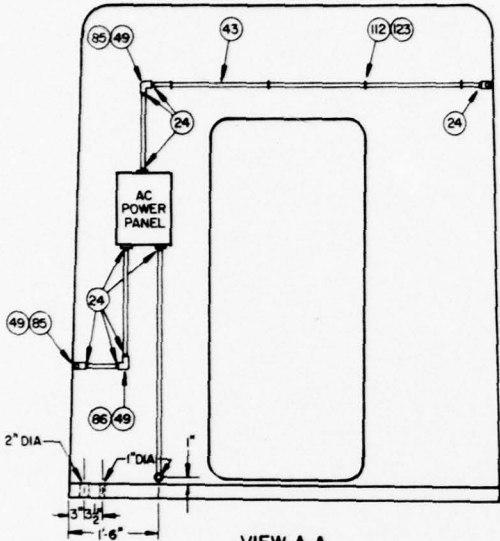

VIEW A-A
AC POWER PANEL CONDUIT INSTALLATION
(NOTE 103)

ITEM	SML	DESCRIPTION	NSN	UI	QTY
145	00569H	WASHER, LOCK .318 ID .586 OD, CADMIUM PLTD	5310-00-407-9886	HD	
140	09139K	WASHER, FLAT, .328 ID, .8594\" OD, CADMIUM PLTD	5310-00-638-1526	EA	
139	24036A	WASHER, FLAT 7/16\" ID, 1\" OD, 5/64 THICK CADMIUM PLTD, 67 PIECES PER LB	NSNR	LB	
133	25257A	UNISTRUT SPRING NUTS, 5/16, PH - P1007	5310-00-886-9948	EA	
123	12165J	STRAP, RETAINING, 1 HOLE, 1/2\" EMT	5340-00-924-1683	HD	
112	15321K	SCREW, WOOD 12 X 1, ROUND HEAD, PHILLIPS TYPE	5305-00-901-2602	GR	
107	25254K	SCREW, HEX HEAD, CAP 5/16 X 1-1/4	5305-00-225-9881	EA	
86	02642B	OUTLET, CONDUIT, TYPE LR, 1/2\" THICKWALL, C-N LR-17	5975-00-655-2776	EA	
85	07210Y	OUTLET, CONDUIT, TYPE LL, 1/2\" THICKWALL, C-N LL-17	5975-00-080-8019	EA	
84	07209D	OUTLET, CONDUIT, TYPE T, 1/2\" THICKWALL, C-N T-17	5975-00-839-5320	EA	
49	02370Y	COVER, CONDUIT OUTLET, 1/2\", FORM 7, BLANK TYPE	5975-00-159-0989	EA	
48	02384L	COUPLING, CONDUIT, THINWALL 1/2\"	5975-00-179-0886	EA	
43	02375J	CONDUIT, METAL, RIGID, 1/2\" EMT, 10 FT LENGTH	5975-00-178-1216	LG	
40	25267Z	CLAMP, PIPE, 1/2\" EMT, UNISTRUT PN P1426	5340-00-978-7088	EA	
34	20846B	CHANNEL, CONT SLOT, 1-5/8\" X 1-5/8\" X 20\", UNISTRUT	7125-00-116-3881	LG	
26	21646W	BUSHING, ANTI-SHORT, 1/2\" PLASTIC, TAB NR 393	NSNR	EA	
24	07708B	BOX CONNECTOR, 1/2\" STEEL, INSULATED, RAINTIGHT, TAB 5123	5975-00-081-9801	EA	
19	09115H	BOLT, LAG, 1/4\" X 1-1/2\"	5306-00-402-5747	EA	

LIST OF MATERIALS					
IDENT NO	ORGANIZATION				
STD-AF-0563 SHEET 1 OF 2	US ARMY COMMUNICATIONS-ELECTRONICS ENGINEERING INSTALLATION AGENCY				
DESIGN BY J COCHRAN	DATE JUL 79	NONDIRECTIONAL BEACON SHELTER CONDUIT & UNISTRUT INSTALLATION			
DRAWN BY JOHN A BODIE	DATE JUL 79				
CHECKED BY P E MYERS, JR	DATE JUL 79				
APPROVAL	ACTIVITY	SIZE	FSCH NO	DRAWING NO	
		D	50470		
PROJECT	SCALE	NONE			

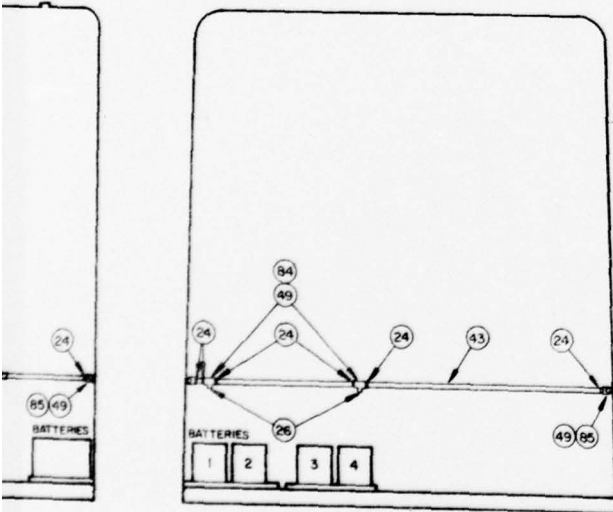

VIEW D-D
BATTERY RACK CONDUIT INSTALLATION

2

4

3

2

0105 FB 1

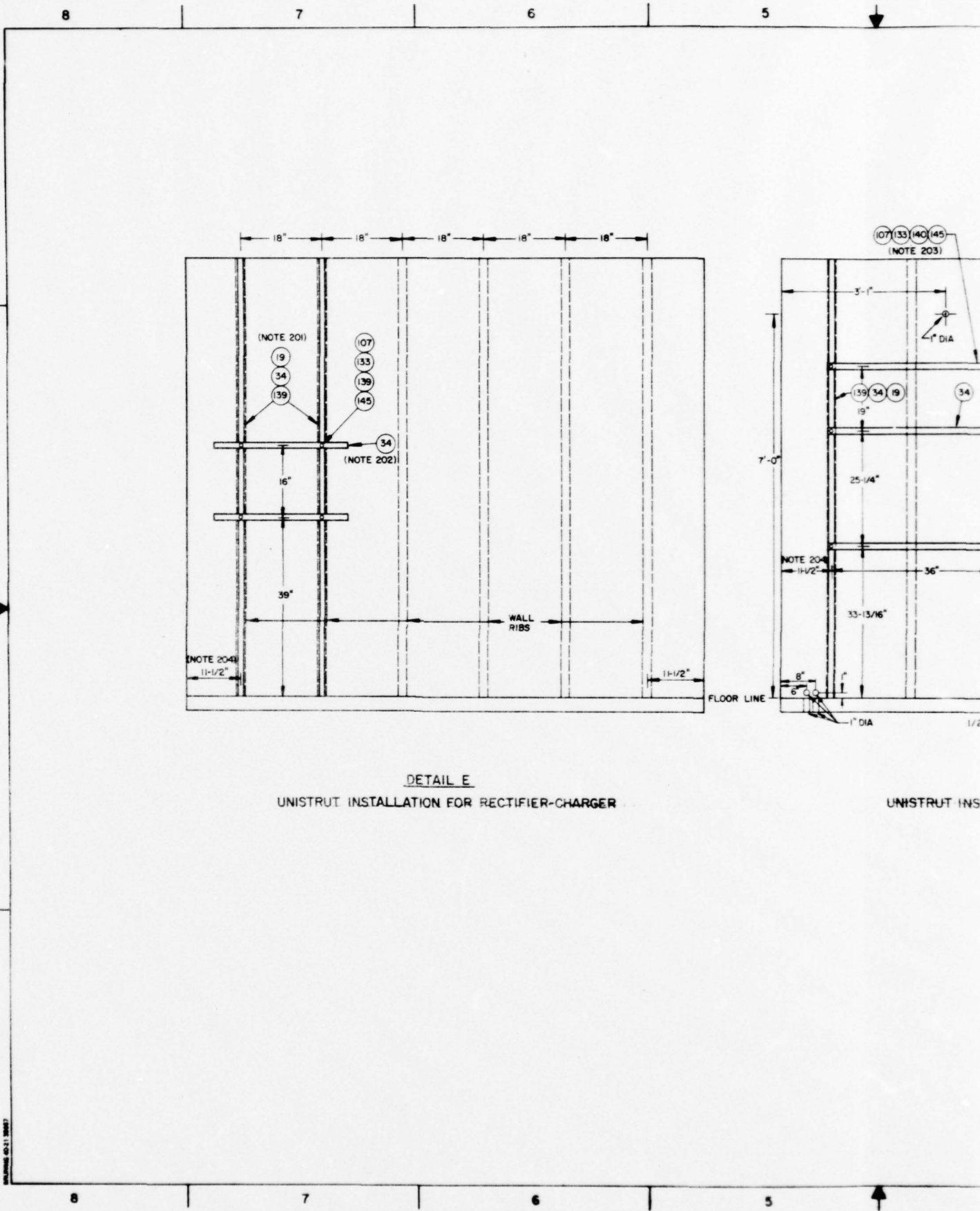

DETAIL E
UNISTRUT INSTALLATION FOR RECTIFIER-CHARGER

UNISTRUT INST

DRAWING © 21 1987

4

3

2

1

REVISION				
ZONE	REV	DESCRIPTION	DATE	APPROVED

NOTES:

- 201. VERTICAL UNISTRUT WILL BE MOUNTED TO WALL RIBS CONTAINING 2" X 3" STUDS AS SHOWN. DIMENSIONS ARE CRITICAL SINCE ONLY WALL STUDS MUST BE USED FOR UNISTRUT MOUNTING.
- 202. HORIZONTAL UNISTRUT WILL BE MOUNTED TO VERTICAL UNISTRUT AS SHOWN. DIMENSIONS ARE CRITICAL SINCE EQUIPMENT MOUNTS ON THE HORIZONTAL UNISTRUT.
- 203. MOUNT EQUIPMENT TO UNISTRUT WITH ITEMS 107, 133, 140, AND 145.
- 204. MEASURE 11-1/2" AT FLOOR LEVEL SINCE WALL SLOPES GRADUALLY. CENTER UNISTRUT ON SUPPORT STUDS.
- 205. FOR EXISTING BUILDINGS, UNISTRUT MOUNTING DIMENSIONS MUST BE ADJUSTED TO THE PARTICULAR BUILDING.
- 206. CABLE ENTRY HOLES ARE PROVIDED BY SHELTER MANUFACTURER AND ARE CAPPED ON THE OUTSIDE. CENTER OF HOLES IN FLOOR IS 1" FROM WALL.

D

C

B

A

THIS DOCUMENT IS BEST QUALITY PRACTICABLE
 THE COPY FURNISHED TO DDC CONTAINED A
 SIGNIFICANT NUMBER OF PAGES WHICH DO NOT
 REPRODUCE LEGIBLY.

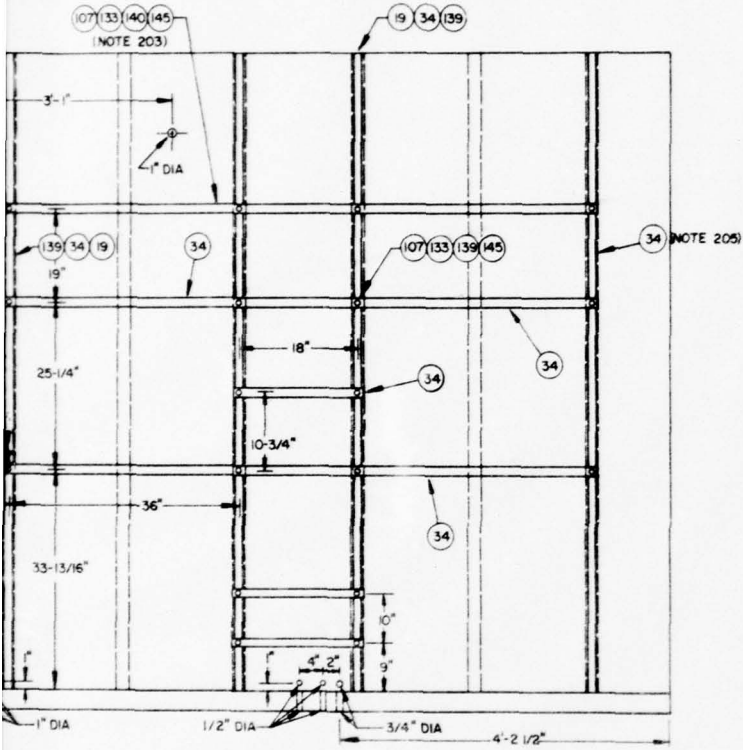

DETAIL F

UNISTRUT INSTALLATION FOR NDB EQUIPMENT
(NOTE 206)

2

IDENT NO. STD-AF-0563	SIZE TECH NO. D 50470	DRAWING NO.
SHEET 2 OF 2	SCALE NONE	DATE 08-04-64
DRAWN BY JOHN A. BOGIE	CHECKED BY	APPROVED BY

21-05-121

4

3

2

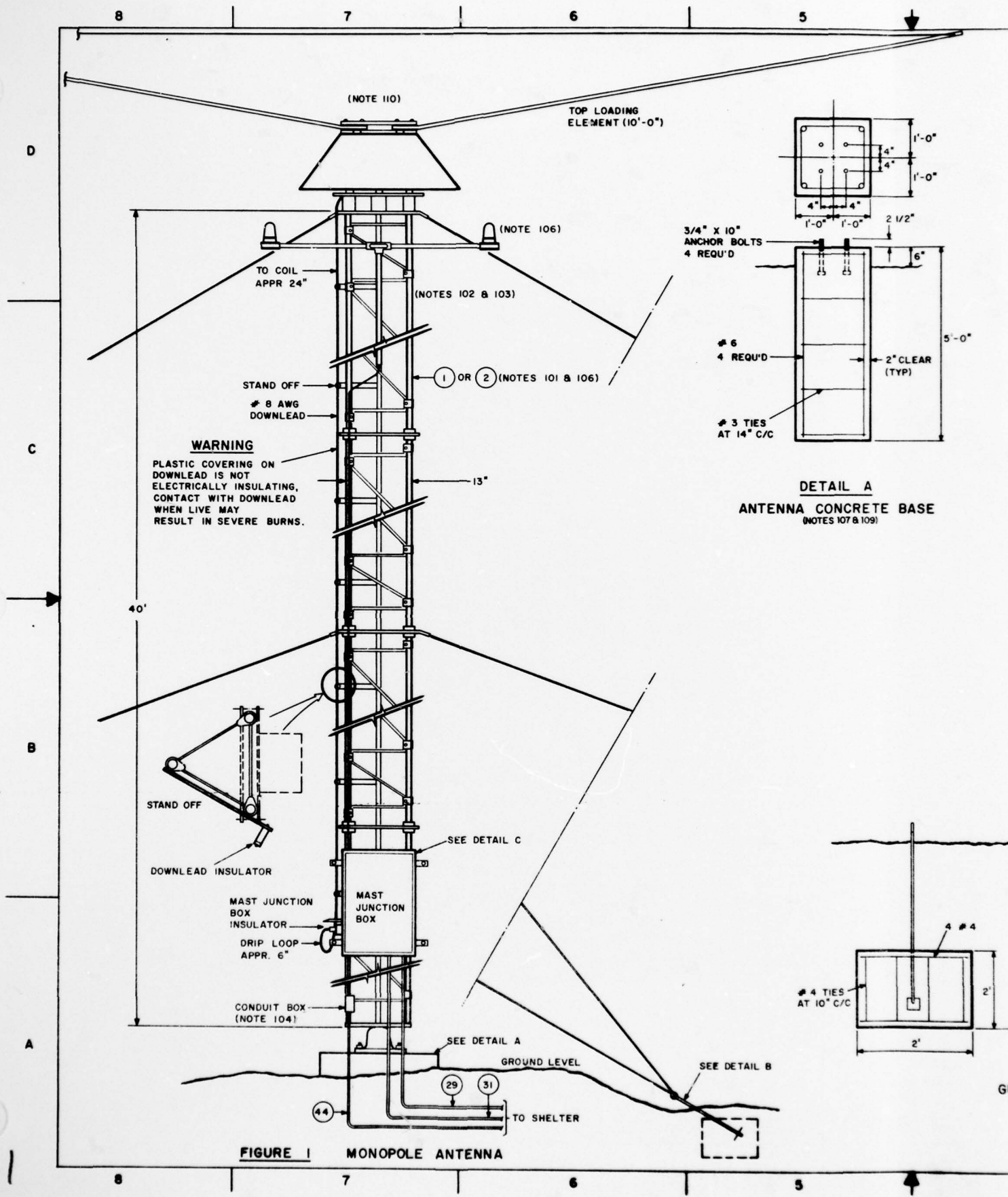
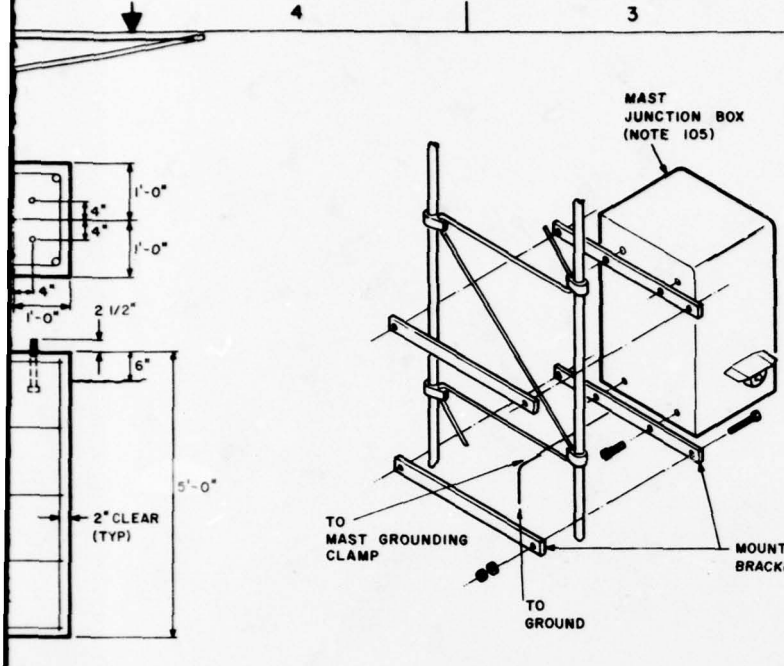

FIGURE 1 MONOPOLE ANTENNA



DETAIL A
CONCRETE BASE
(S 107 & 109)

DETAIL C
MAST JUNCTION BOX
INSTALLATION

ZONE REV		REVISION	DATE	APPROVED

- NOTES:
101. MONOPOLE ANTENNA CONSISTS OF AN ANTENNA MAST COMPLETE WITH ALL NECESSARY HARDWARE, TURNBUCKLES, GUYS, AND FOUNDATION EMBEDDED PARTS; RADIATOR; INSULATORS AND PROTECTIVE COIL; CUSTOM WOUND PRIMARY LOADING COIL; DOWNLEAD AND DOWNLEAD INSULATORS; TUNING/MATCHING UNIT; AND GROUND SCREEN MATERIAL.
 102. ANTENNA MAST IS SUPPLIED IN FOUR 10-FOOT SECTIONS. TWO SECTIONS ARE PAINTED WHITE AND TWO ARE PAINTED INTERNATIONAL ORANGE. ASSEMBLE SECTIONS WITH COLORS ALTERNATING AND WITH ORANGE AT TOP.
 103. MAST VERTICAL MEMBERS ARE 1 1/16"-DIAMETER ALUMINUM RODS; LATTICE MEMBERS ARE 3/8"-DIAMETER ALUMINUM RODS.
 104. THE JUNCTION BOX AND ALL WIRING AND CONDUIT FROM THE BOX TO THE OBSTRUCTION LIGHTS ARE FURNISHED WITH THE TOWER. CONDUIT TO MATE WITH THE 3/4" JUNCTION BOX HUB, WIRE NUTS, AND 3-CONDUCTOR POWER CABLE MUST BE INCLUDED AS PART OF THE SITE SUPPORT OR IN THE E.I.P.
 105. LETHAL VOLTAGES ARE PRESENT AT THE MAST JUNCTION BOX. DO NOT MAKE ANY ADJUSTMENTS UNLESS THE SYSTEM IS SWITCHED OFF.
 106. THE PARAG ANTENNA (ITEM 1) DOES NOT INCLUDE OBSTRUCTION LIGHTS. WHEN OBSTRUCTION LIGHTS ARE REQUIRED, ORDER THE PARAG ANTENNA (ITEM 2).
 107. THE MONOPOLE ANTENNA CONCRETE FOUNDATION SHALL BE CONSTRUCTED AS FOLLOWS:
 - A. ALL CONCRETE SHALL HAVE A MINIMUM 28 DAY COMPRESSIVE STRENGTH OF 3000 PSI, 5" SLUMP.
 - B. ALL REINFORCING SHALL BE DEFORMED HARD GRADE RAIL OR BILLET STEEL CONFORMING TO THE REQUIREMENTS OF THE LATEST ISSUE OF CSA G30-12 AND G30-13.
 - C. ALL FOOTINGS SHALL BE FOUNDED ON UNDISTURBED MATERIAL.
 - D. DESIGN IS BASED ON AN ALLOWABLE BEARING PRESSURE OF 3000 PSI FOR SOIL IN ITS NATURAL STATE (IN SITU SOIL).
 - E. ALL FORMWORK SHALL BE REMOVED PRIOR TO BACKFILL.
 108. THE MONOPOLE ANCHOR DESIGN IS BASED ON A HORIZONTAL BEARING CAPACITY OF 400 PSI PER LINEAL FOOT OF DEPTH AND UNITY HEIGHT OF 110 PCF OF IN SITU SOIL. THIS WOULD NOT APPLY TO NON-COESIVE, SATURATED OR SUBMERGED SOILS.
 109. ANTENNA ERECTION SHALL NOT BEGIN UNTIL AT LEAST 7 DAYS AFTER CONCRETE PLACEMENT.
 110. LIGHTNING PROTECTION IS INCORPORATED IN THE ANTENNA DESIGN. A SEPARATE LIGHTNING ROD SHOULD NOT BE INSTALLED AT THE TOP OF THE POLESTAR ANTENNA.

THIS DOCUMENT IS BEST QUALITY PRACTICABLE.
THE COPY FURNISHED TO DDC CONTAINED A
SIGNIFICANT NUMBER OF PAGES WHICH DO NOT
REPRODUCE LEGIBLY.

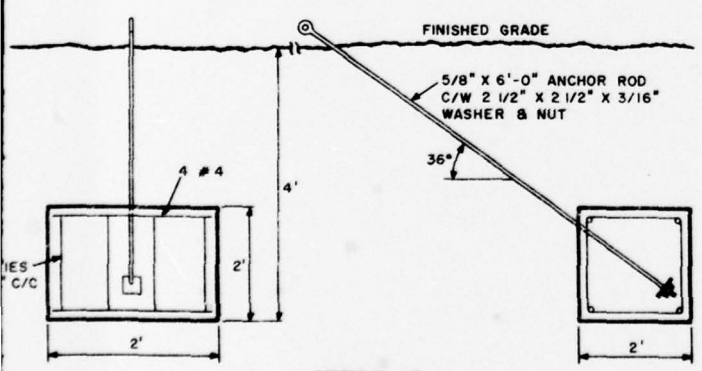

DETAIL B
GUY ANCHOR BLOCK
(NOTE 108)

ITEM	QTY	DESCRIPTION	NSN	UI	QTY
165	216446	WIRE NUTS, TWO #14 ANG MIN. 2 #10 ANG & 1 #12 ANG MAX, T&B PT-28	NSNR	EA	
158	195252	WIRE, ELEC, 14 ANG, GRN STRANDED	6145-00-043-1255	FT	
157	07461Q	WIRE, ELEC, 14 ANG, WHITE STRANDED	6145-00-052-3278	FT	
156	035056	WIRE, ELEC, 14 ANG, BLK STRANDED	6145-00-184-5341	FT	
44	024460	CONDUIT, METAL, RIGID, 3/4" THICKWALL, 10 FT LENGTH	5975-00-226-6004	L6	
31	25111K	CABLE, RF, 1/2 INCH JACKETED FOMFLEX, PHELPS DODGE FX 12-50H	NSNR	FT	
29	12314E	CABLE, 6 PAIR, DIRECT BURIAL, 22 ANG	6145-00-933-7283	FT	
2	25118E	ANTENNA, MONOPOLE, NAUTEL PARAGAL	NSNR	EA	
1	25117D	ANTENNA, MONOPOLE, NAUTEL PARAG	NSNR	EA	

LIST OF MATERIALS

IDENT NO: **STD-AF-0564**
SHEET 1 OF 2

ORGANIZATION: **US ARMY COMMUNICATIONS-ELECTRONICS ENGINEERING INSTALLATION AGENCY**

DESIGN BY: **J. COTHMAN** DATE: **MAY 79**
DRAWN BY: **S.D.H.** DATE: **MAY 79**
CHECKED BY: **F. MYERS** DATE: **MAY 79**

PROJECT: **NONDIRECTIONAL BEACON MONOPOLE ANTENNA/COUNTERPOISE**

APPROVAL: [Signature] ACTIVITY: **CC-504-208** SIZE: **D** FSCN NO: **50470** DRAWING NO. [Blank]

DATE: **01-05-72**

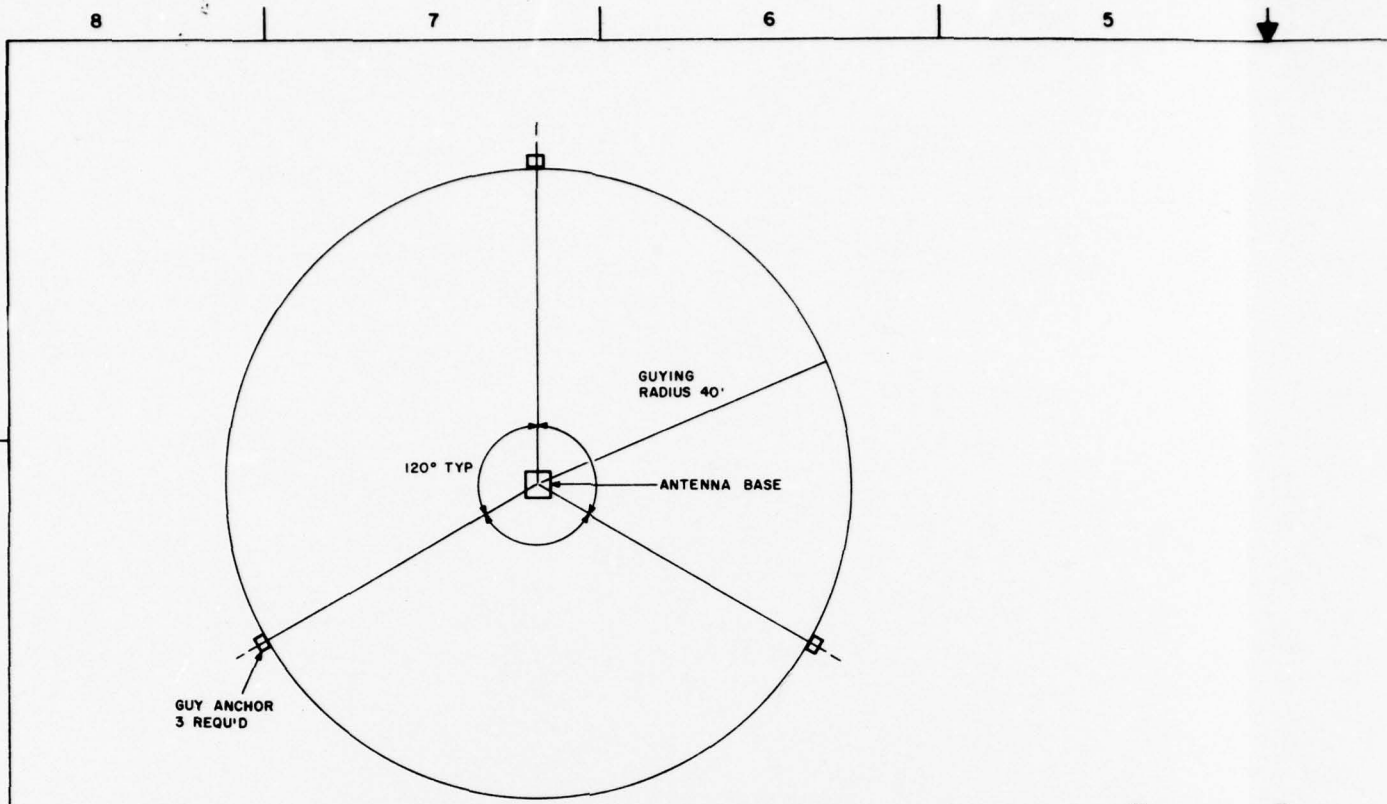

FIGURE 2
MAST GUYING LAYOUT

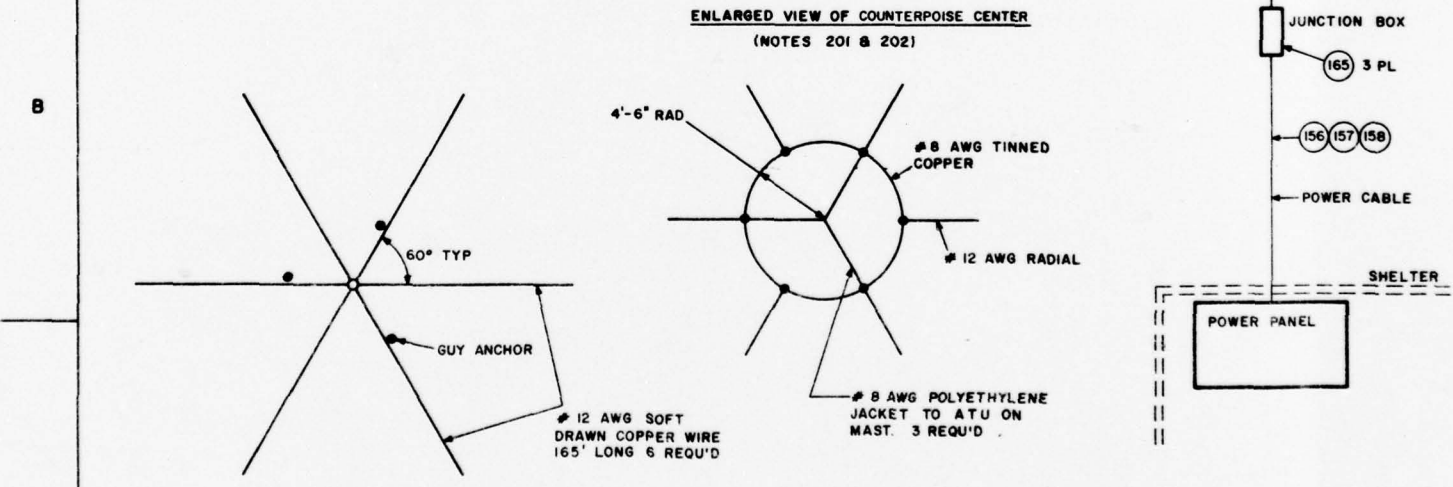

FIGURE 3
COUNTERPOISE INSTALLATION DETAILS

4

3

2

1

REVISION				
ZONE	REV	DESCRIPTION	DATE	APPROVED

NOTES:

- 201. UNLESS SITE CONDITIONS DICTATE OTHERWISE, CONDUITWORK SHOULD BE BURIED TO A DEPTH OF AT LEAST 6".
- 202. ALL JOINTS SHOULD BE A MINIMUM OF FOUR TURNS OF ONE WIRE AROUND THE OTHER AND SOLDERED. SILVER SOLDER IS RECOMMENDED.
- 203. CONNECTORS ARE FURNISHED WITH EQUIPMENT. P1 IS A COAXIAL TYPE N CONNECTOR, PHELPS DODGE 720000. P2 IS A 7-PIN CABLE CONNECTOR, CANNON MS3106F16S-1S.
- 204. MAST JUNCTION BOX CONTAINS THE ANTENNA TUNING UNIT.
- 205. OBSTRUCTION LIGHTING KIT CONSISTS OF TWO AVIATION RED, DOUBLE INCANDESCENT FIXTURES; A MOUNTING ASSEMBLY COMPOSED OF 1" CONDUIT AND FITTINGS; AND SUFFICIENT WEATHERPROOF ARMORED CABLE TO REACH ANTENNA BASE AND ALL NECESSARY MOUNTING WIRING.

D

C

B

A

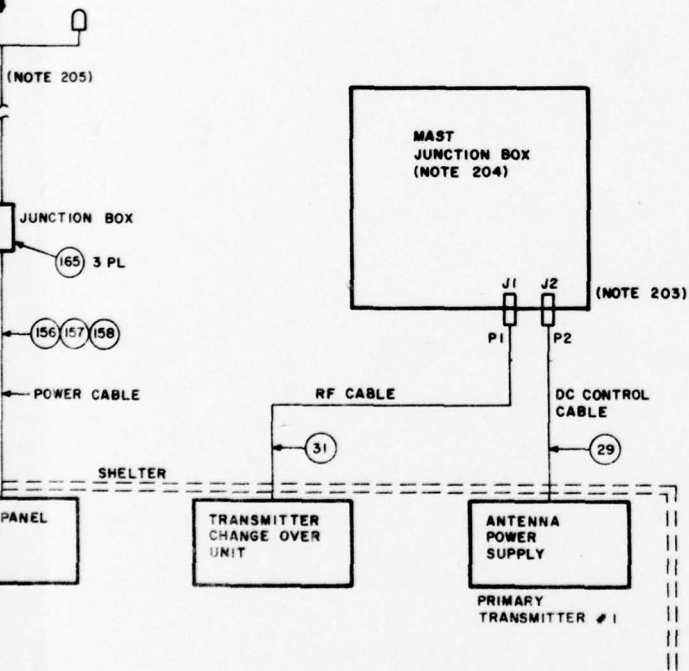

FIGURE 4
ANTENNA TO SHELTER
INTERCONNECTION

2

DRAWING NO. STD-AF-0564 SHEET 2 OF 2	SIZE FROM NO. D 50470	DRAWING NO.
DRAWN BY S. D. M.	CHECKED [Signature]	DATE 01-05-19
APPROVED [Signature]	SCALE NONE ENTERED IN USACETIA SPEC	SHEET 2 OF 2

4

3

2

1

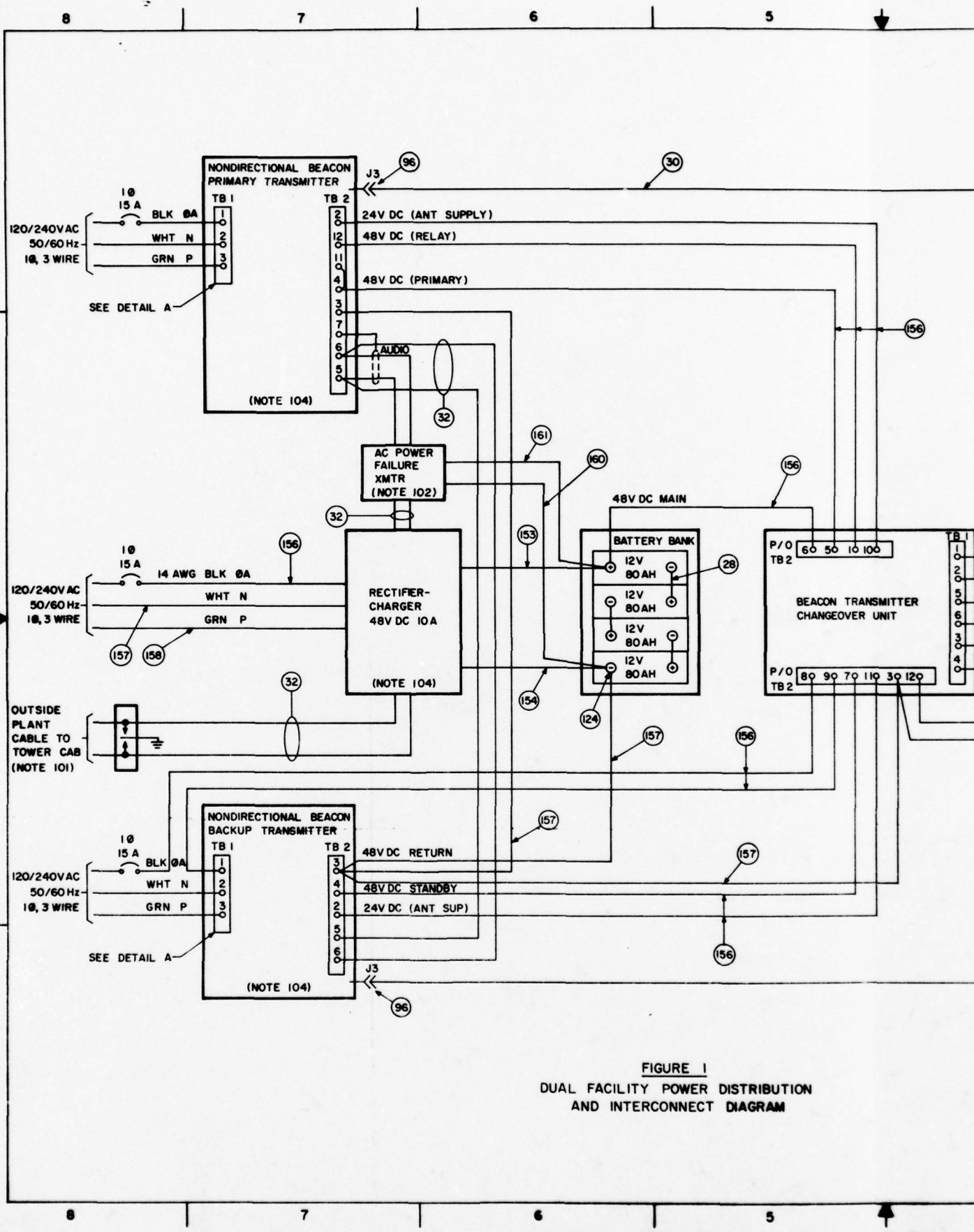
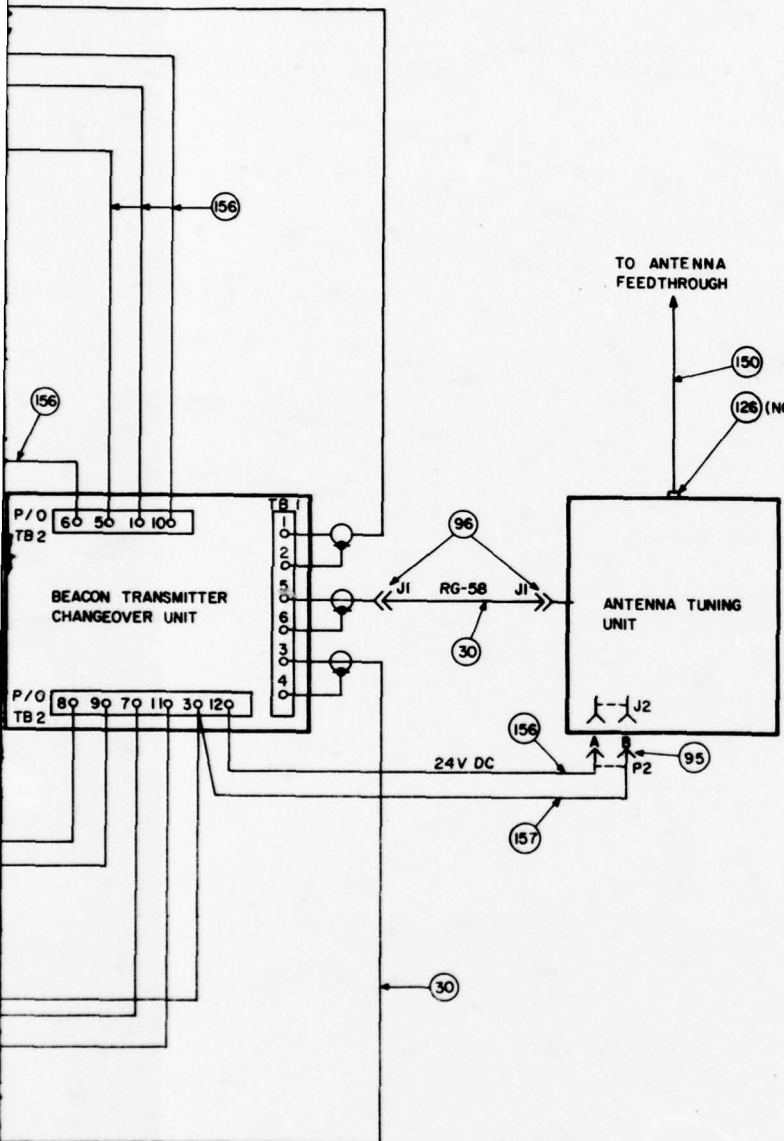

FIGURE 1
 DUAL FACILITY POWER DISTRIBUTION
 AND INTERCONNECT DIAGRAM

REVISION				
ZONE	REV	DESCRIPTION	DATE	APPROVED

NOTES:

- 101. WHEN AVAILABLE, ONE OUTSIDE PLANT CABLE PAIR WILL BE USED FOR THE AC POWER FAILURE TRANSMISSION TO THE TOWER CAB. REFER TO STD-AF-0566, SHEET 1, FOR DETAILS.
- 102. WHEN AN OUTSIDE PLANT CABLE PAIR IS NOT AVAILABLE, THE 1000 TRANSMITTER AND ANTENNA WILL BE USED TO TRANSMIT THE AC POWER FAILURE INDICATION TO THE TOWER CAB. REFER TO STD-AF-0566, SHEET 2, FOR DETAILS.
- 103. MARK WIRES USING CABLE MARKERS, ITEMS 69-74, 14M EIP WIRE RUNNING LISTS.
- 104. ADJUST THE MAIN RECTIFIER-CHARGER FOR A FLOAT VOLTAGE OF 52.8 VDC AT THE BATTERY TERMINALS. ADJUST THE OUTPUT OF EACH BEACON TRANSMITTER INTERNAL TRICKLE CHARGER TO 52.5 VDC.
- 105. ANTENNA TUNING UNIT FEEDTHROUGH INSULATOR CONES COMPLETE WITH 1/4" NUT, WASHER, AND LOCKWASHER FOR INSTALLATION OF TERMINAL LUG.



ITEM	QTY	DESCRIPTION	NSN	UI	QTY
161	23193Y	WIRE, ELEC, TW, STRAN, 18 AWG, BLACK	6145-00-524-9130	FT	
160	23192P	WIRE, ELEC, TW, STRAN, 18 AWG, WHITE	NSNR	FT	
158	19525Z	WIRE, ELEC, 14 AWG, GRN STRANDED	6145-00-043-1295	FT	
157	07461Q	WIRE, ELEC, 14 AWG, WHITE STRANDED	6145-00-052-3278	FT	
156	03505E	WIRE, ELEC, 14 AWG, BLK STRANDED	6145-00-104-5341	FT	
154	03507N	WIRE, ELEC, 10 AWG, WHT SOLID	6145-00-104-5346	FT	
153	03538E	WIRE, ELEC, 10 AWG, BLK SOLID	6145-00-191-2575	FT	
124	25256Z	TERMINAL, BATTERY POST, MEDIUM DUTY, 4 AWG - 2/0, 5/PG, BELDEN P/N 7498	5940-00-100-0161	PG	
96	06882M	PLUG, COAXIAL, A TYPE, RF UG 536 B/U	5935-00-660-4296	EA	
95	25268P	PLUG, CONNOR NS 3106TAS-7P, 3 PTR	5935-00-201-6655	EA	
74	21315H	MARKER, CABLE, TAB DPWCS-335.	NSNR	PG	
73	21311D	MARKER, CABLE, S, TAB DPWCS.	NSNR	PG	
72	21314G	MARKER, CABLE, P, TAB DPWCS.	NSNR	PG	
71	25242L	MARKER, CABLE, G, TAB DPWCS.	NSNR	PG	
70	21313F	MARKER, CABLE, D, TAB DPWCS.	NSNR	PG	
69	21312E	MARKER, CABLE, A, TAB DPWCS.	NSNR	PG	
32	03733D	CABLE, SHIELDED COND, 1 PR, 22 AWG, STRANDED, BARE WIRE	6145-00-643-0307	FT	
30	03623D	CABLE, RG 58C/U 50 OHM, COAX, 21 AWG STRANDED	6145-00-542-6092	FT	
28	25237C	CABLE, BATTERY, 1 GAGE, 12" LONG, BELDEN P/N 71241	NSNR	EA	

LIST OF MATERIALS

IDENT NO: **STD-AF-0565**
SHEET 1 OF 2

ORGANIZATION: **US ARMY COMMUNICATIONS-ELECTRONICS ENGINEERING INSTALLATION AGENCY**

DESIGN BY: J. COTHRAIN DATE: JUL 79
DRAWN BY: G. VERDI DATE: JUL 79
CHECKED BY: F.E. MYERS, JR DATE: JUL 79

NONDIRECTIONAL BEACON AC AND DC POWER DISTRIBUTION

APPROVAL: [Signature] ACTIVITY: [Signature] SIZE: D FSCM NO: 50470 DRAWING NO: [Blank]
SCALE: NONE

2

01-65 1 2 1

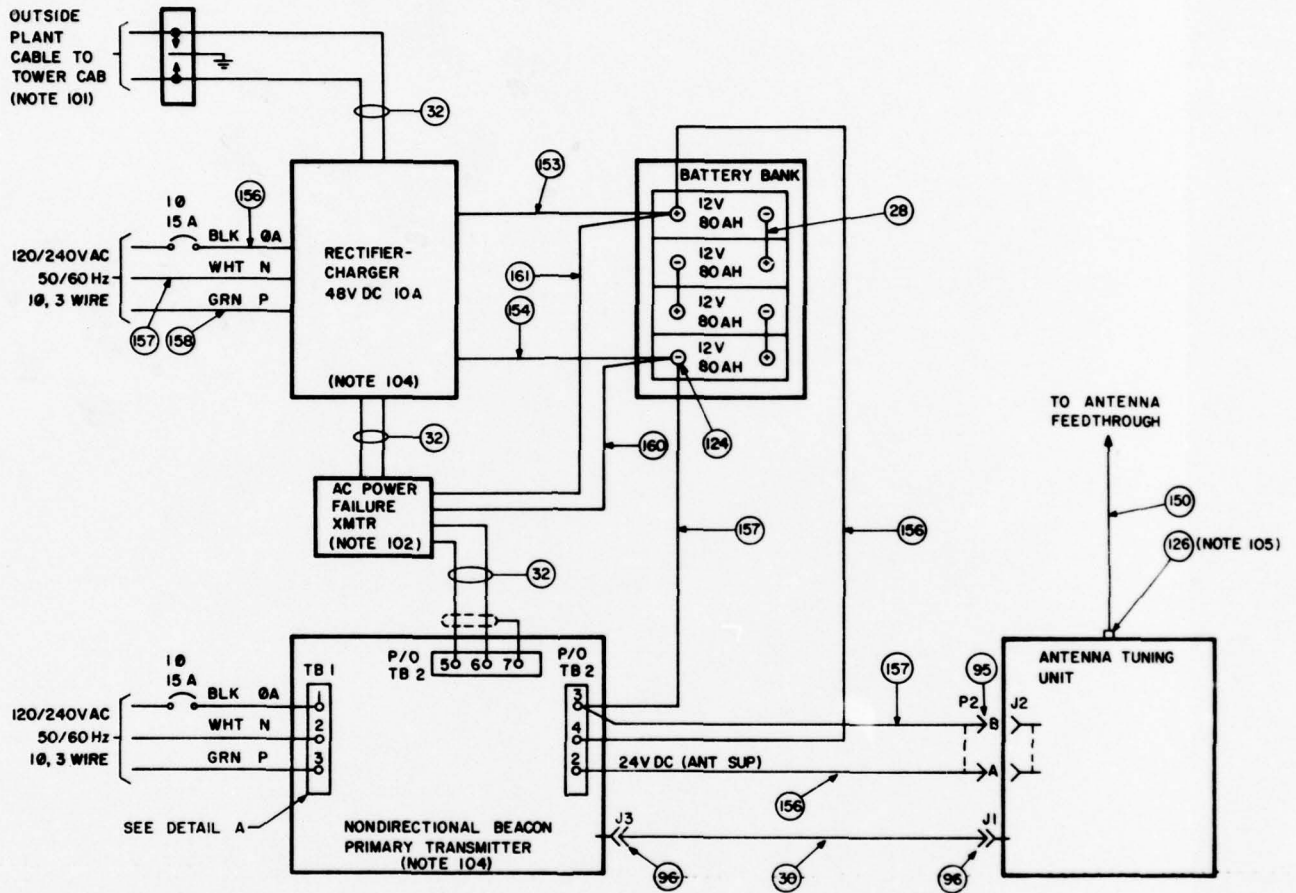

FIGURE 2
SINGLE FACILITY POWER DISTRIBUTION
AND INTERCONNECTION DIAGRAM

A

B

C

D

REVISION 04-21 1967

4 3 2 1

REVISION				
ZONE	REV	DESCRIPTION	DATE	APPROVED

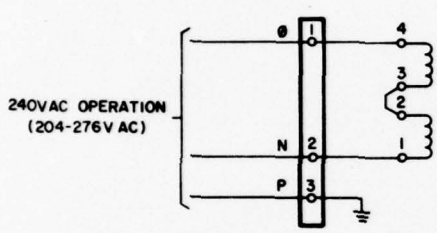
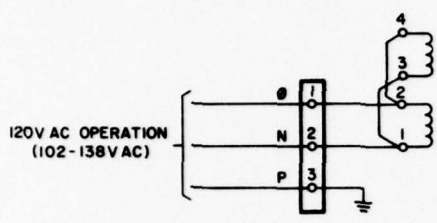

DETAIL A
NDB TRANSMITTER AC POWER
STRAPPING CONNECTIONS

(150)
 (126) (NOTE 105)

G

D
 C
 B
 A

2

IDENT NO STD-AF-0565	SIZE D	PSCH NO 50470	DRAWING NO
DRAWN BY <i>G. VERN</i>	SCALE NONE	ENTERED IN DISCREETARY	DATE
APPROVED <i>[Signature]</i>	DATE	ENTERED IN DISCREETARY	DATE

4 3 2 1

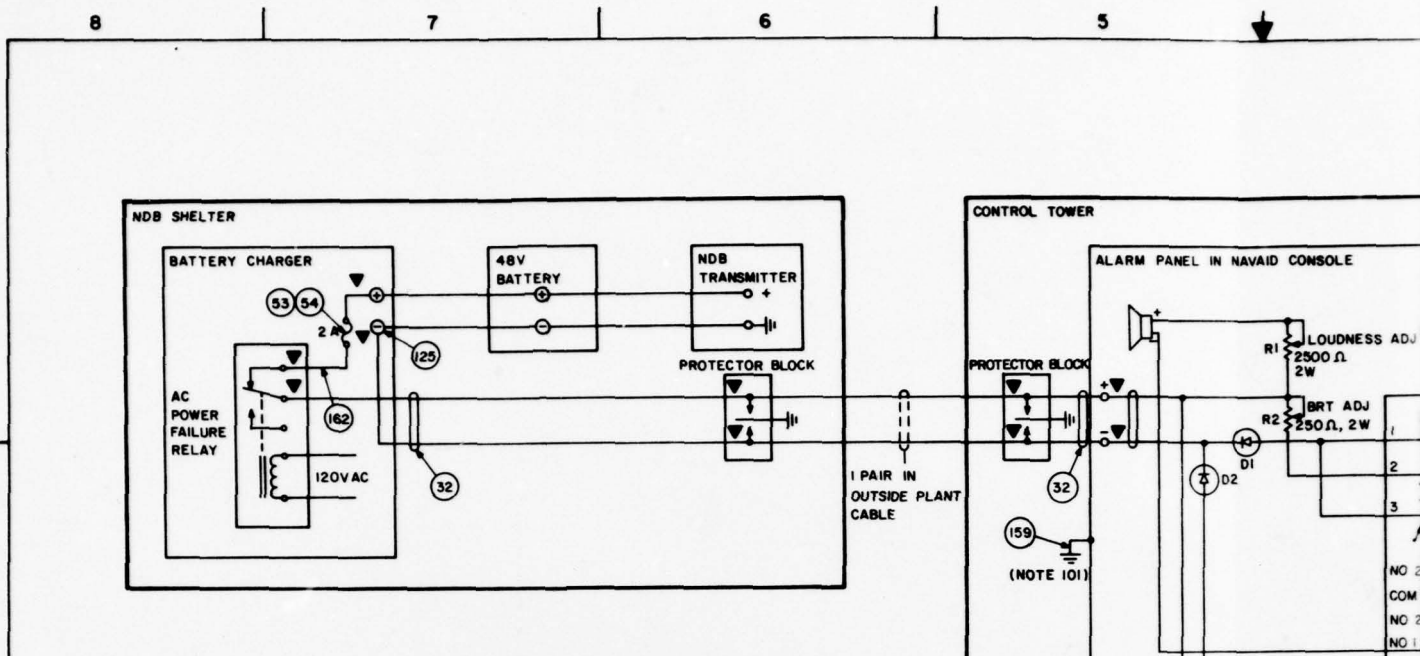

FIGURE 1
 NDB AC POWER FAILURE INDICATION CIRCUIT
 SCHEMATIC USING LANDLINE CABLE PAIR

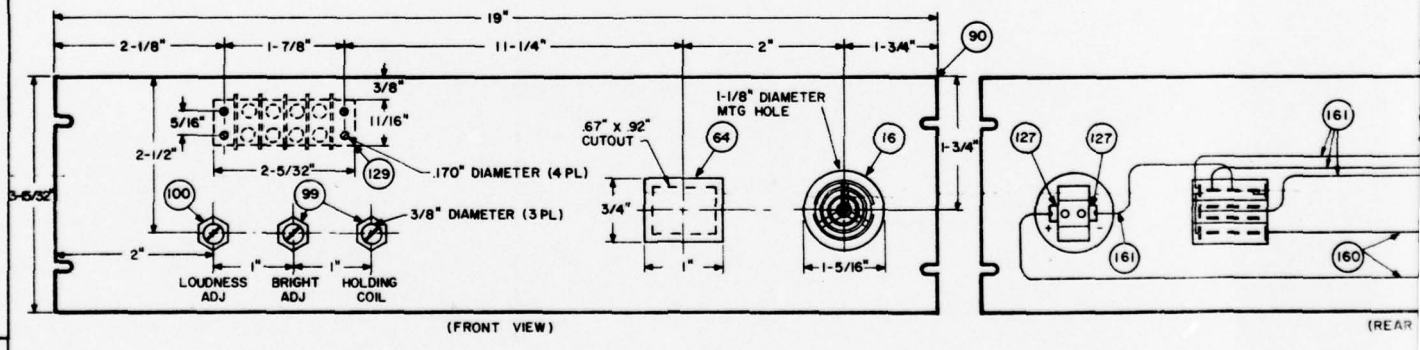

FIGURE 2
 AC POWER FAILURE RECEIVER PANEL LAYOUT

FIGURE 3
 AC POWER FAILURE RECEIVER PANEL LAYOUT

REVISION				
ZONE	REV	DESCRIPTION	DATE	APPROVED

LEGEND:
 INSTALLER WIRING CONNECTION
 GROUND CONNECTION

NOTES:
 101. GROUND FOR THE AC POWER FAILURE RECEIVER PANEL IS BY METAL-TO-METAL CONTACT WITH THE CONSOLE. IF THE CONSOLE IS NOT GROUNDED TO THE TOWER CAB GROUND, CONNECT ALARM PANEL TO THE TOWER GROUND BOX USING #18 AWG GREEN WIRE.

THIS DOCUMENT IS BEST QUALITY PRACTICABLE. THE COPY FURNISHED TO DDC CONTAINED A SIGNIFICANT NUMBER OF PAGES WHICH DO NOT REPRODUCE LEGIBLY.

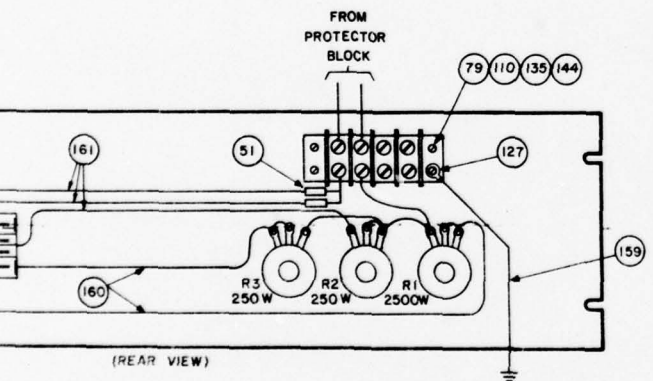
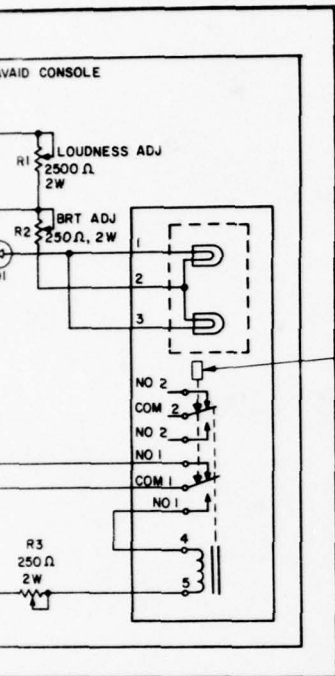

ITEM	SML	DESCRIPTION	NSN	UI	QTY
162	16954C	WIRE, ELEC, TW, STRAN, 20 AWG, BLUE, BELDEN 8919-13	NSNR	FT	
161	23193Y	WIRE, ELEC, TW, STRAN, 18 AWG, BLACK	6145-00-524-9130	FT	
160	23192P	WIRE, ELEC, TW, STRAN, 18 AWG, WHITE	NSNR	FT	
159	20815D	WIRE, ELEC, TW, STRAN, 18 AWG, GREEN	6145-00-726-6931	FT	
145	00569H	WASHER, LOCK, .318 ID, CAD PLTD	5310-00-407-9566	HD	
144	09019J	WASHER, LOCK, SPLIT, STEEL, CAD PLTD, #8	5310-00-045-3299	HD	
143	09021X	WASHER, LOCK, SPLIT, STEEL, CAD PLTD, #6	5310-00-839-3770	HD	
135	00487C	WASHER, FLAT, STEEL, CAD PLTD, #8	5310-00-167-0833	HD	
133	25257A	UNISTNUT SPRING NUTS, 5/16", P1007	5310-00-046-5948	EA	
129	25250B	TERMINAL STRIP, BARRIER, 4 POSITION SOLDER TERMINALS, CLW715 1504-S7	NSNR	EA	
127	21718E	TERMINAL LUG, #18-14 AWG, T-B RB064	NSNR	EA	
125	21720F	TERMINAL LUG, #22-18 AWG, T-B RA1123	NSNR	EA	
119	16917Z	STEEL, BAR, COLD ROLLED, 1-1/4" X 3/8"	9510-00-596-2029	FT	
110	21853G	SCREW, MACH, PAN HEAD, CAD PLTD, 8-32 X 5/8 IN LG	5305-00-904-6194	HD	
108	25255J	SCREW, MACH, PAN HEAD, 6-32 X 5/8" LG	5305-00-638-0802	HD	
107	25254K	SCREW, HEX HEAD, CAP 5/16 X 1-1/4	5305-00-225-9001	EA	
100	25283Y	POTENTIOMETER, DUAL, 2.5K OHMS, ALLEN BRADLEY JD1N200P252UA	NSNR	EA	
99	25284N	POTENTIOMETER, DUAL, 250 OHMS, ALLEN BRADLEY JD1N200P251UA	NSNR	EA	
90	08712Z	PANEL, BLANK, 19" X 3-1/2" X 1/8", GREY	5975-00-686-2541	EA	
81	07679A	NUT, PLAIN, HEX, 5/16"-18	5310-00-880-7744	EA	
79	07675L	NUT, PLAIN, HEX, STEEL, CAD PLTD, 8-32	5310-00-550-2490	HD	
64	25285M	LAMP ASSEMBLY, DUAL, TELLITE, 90EA2C2-F3J1(R)LI-NI	NSNR	EA	
54	25281Q	FUSE, 3AG, NORMAL, 2A, LITTLEFUSE 312002	5920-00-280-5062	EA	
53	25265K	FUSE HOLDER, IN-LINE, LITTLEFUSE 15502D	5920-00-199-9235	EA	
51	25226J	DIODE, RECTIFIER, GENERAL PURPOSE, 1A, 200 PRV, 1N 4003	5961-00-880-2938	EA	
32	037330	CABLE, SHIELDED COND, 1 PR, 22 AWG, STRANDED, BARE WIRE	6145-00-643-0307	FT	
20	11115E	BOLT, MACH, HEX HD, 5/16" X 1" LG, STEEL	5306-00-543-4405	EA	
16	25259C	AUDIBLE ALARM UNIT, SONALERT, HALLLOW SC710M	6350-01-044-2508	EA	
13		SIGNALING SYSTEM, EBM INBAND CONSISTING OF: 19931J COMMN MODULE, MESCOM 451 199286 SIGNALING MODULE, MESCOM 452-PMA 25296H APPARTUS CASE, MESCOM 12A EQUIPPED WITH MESCOM 400-2 MOUNTING ASSEMBLY	NSNR	EA	
10	25113Z	CONVERTER, +48V TO -48V DC, BIKOR DDU 4807	NSNR	EA	

FIGURE 3 AC POWER FAILURE RECEIVER PANEL WIRING CONNECTIONS

LIST OF MATERIALS			
IDENT NO	STD-AF-0566	ORGANIZATION	US ARMY COMMUNICATIONS-ELECTRONICS ENGINEERING INSTALLATION AGENCY
DESIGN BY	J. COTHMAN	DATE	JUL 79
DRAWN BY	G. VERDI	DATE	JUL 79
CHECKED BY	F.E. MYERS, JR.	DATE	JUL 79
APPROVAL	ACTIVITY	SIZE	FSC# NO
		D	50470
			DRAWING NO.

2

0105-F2 1

8

7

6

5

D

C

B

A

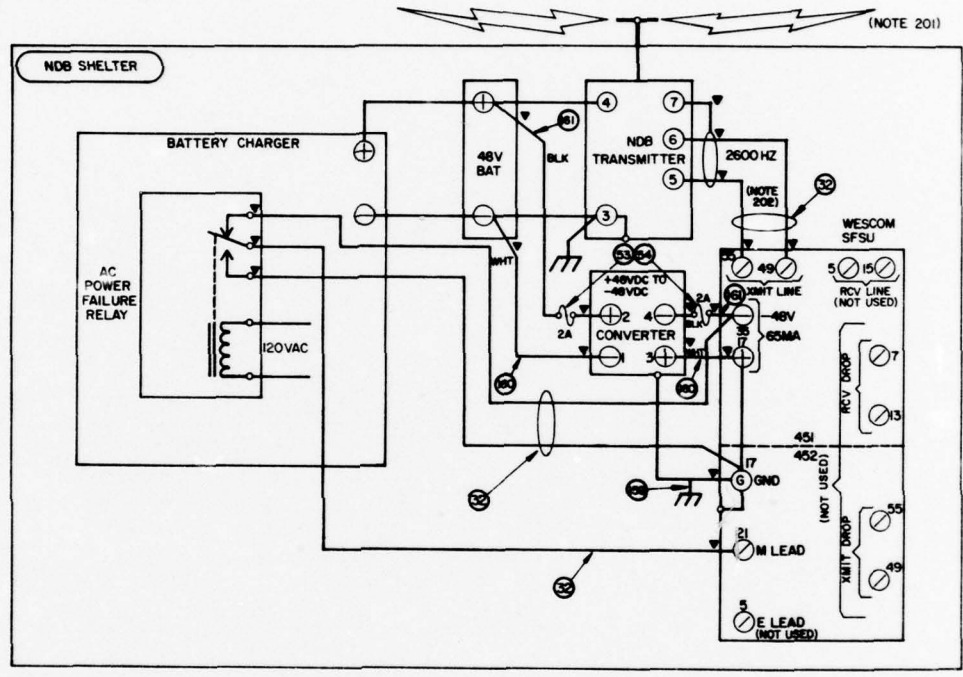

FIGURE 4
AC POWER FAILURE INDICATION
CIRCUIT SCHEMATIC USING
NDB TRANSMITTER AND ANTENNA

1
 8
 7
 6
 5

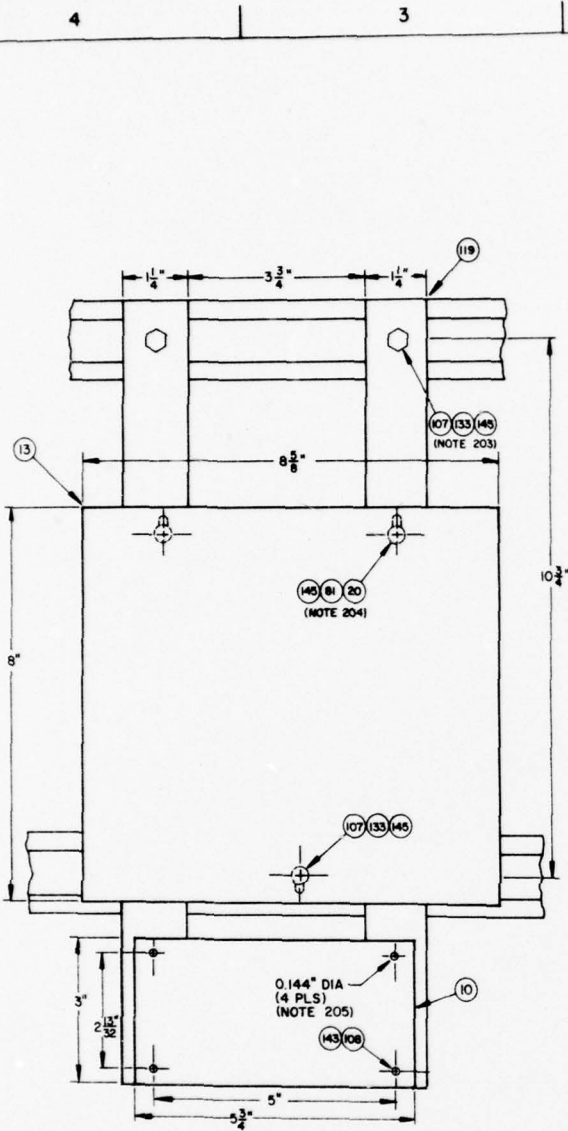

FIGURE 5
SIGNALING ASSEMBLY AND
POWER SUPPLY MOUNTING DETAILS

REVISION				
ZONE	REV	DESCRIPTION	DATE	APPROVED

LEGEND:

- ▼ INSTALLER WIRING CONNECTION
- /// GROUND CONNECTION

NOTES:

201. THE MOB MONITOR RECEIVER LOCATED IN THE TOWER CAB IS USED TO DETECT THE 2600-KHZ TONE.
202. ADJUST THE TONE LEVEL FOR 20 PERCENT MODULATION OF MOB CARRIER.
203. DRILL 11/32" HOLES IN STEEL BAR FOR MOUNTING TO UNISTRUT.
204. DRILL 11/32" HOLES IN STEEL BAR FOR MOUNTING SIGNALING ASSEMBLY. USE MESCON 400-2 MOUNTING ASSEMBLY AS A TEMPLATE FOR LOCATING MOUNTING HOLES.
205. DRILL 0.144" DIAMETER HOLES USING NO. 27 DRILL FOR MOUNTING POWER SUPPLY. POWER SUPPLY CASE CONTAINS FOUR #6-32 THREADED HOLES FOR MOUNTING.

D
C
B
A

2

DEVT NO STD-AF-0506	SIZE D	PCBN NO 50470	ISSUE NO 1
DRAWN BY JOHN A. ROSE	DATE NONE	ENGR BY NONE	CHKD BY NONE
APPROVED <i>[Signature]</i>		01-05-F21	

15 November 1979

SEIP 013

SECTION 5. BILL OF MATERIALS

5.1 GENERAL. The BOM provided in this section, figure 5-1, illustrates the essential materials required for the installation of an NDB facility. It is for a typical installation and should be modified and supplemented by the responsible engineering activity to fit the particular site.

5.2 BILL OF MATERIALS. The BOM contains USACC standard authorized materials which are to be used in the preparation of individual EIPs. Requests for significant changes to the BOM will be submitted to Headquarters, USACEEIA, ATTN: CCC-CED-SEP, with justification for approval. Identification of items is primarily by National Stock Number (NSN), Management Control Number (MCN), and System Material List (SML) number. When military identification numbers are not available, the manufacturer's part description and number (or catalog number) with approximate cost will be provided. The number in parentheses in the Stock Number column is the SML number.

LOCATION		SEIP 013		UNIT IDENT CODE	
<p>TELECOMMUNICATIONS DEVELOPMENT PROJECT - BILL OF MATERIALS For use of this form, see AM 10-22, the submittal policy in the United States Army Communications Command.</p>					
SELLER NUMBER	STOCK NUMBER	NOMENCLATURE	DATE	PAGE NO.	NO. OF PAGES
ITEM NO.			UNIT	TOTAL AVAILABLE FOR PROJECT COMMAND	REQUIRED
1	MSNR (25117D)	Antenna, Monopole, Single Guyed Lattice Tower with Hexagon-Shaped, Capacitive-Loading Structure, 200-1500 KHz (Custom Wound--Actual Operating Frequency Must Be Specified), 400 Watts Peak, 50 Ohms, 40' High, Complete With All Necessary Hardware, Turnbuckles, Guys, Foundation Embedded Parts; Radiator; Insulators and Protective Cowl; Custom Wound Principal Loading Coil; Downlead and Downlead Insulators; Tuning Matching Unit; and Ground Screen Material; Nautel PA40A.	EA		
2	MSNR (25118E)	Antenna, Monopole, Single Guyed Lattice Tower with Hexagon-Shaped, Capacitive-Loading Structure, 200-1500 KHz (Custom Wound--Actual Operating Frequency Must Be Specified), 400 Watts Peak, 50 Ohms, 40' High, Complete with all Necessary Hardware, Turnbuckles, Guys, Foundation Embedded Parts; Radiator; Insulators and Protective Cowl; Custom Wound Principal Loading Coil; Downlead and Downlead Insulators; Tuning Matching Unit; Ground Screen Material; and Obstruction Lighting Kit; Nautel PA40AL.	EA		
3	MSNR	Antenna, Whip, ND3 Monitor Receiver (Antenna Presently Being Procured Under Contract - Details and SML Number to be Provided Later).	EA		
4	MSNR (25122K)	Antenna, Tuning Unit, F/U/W Nautel FA 9782 NDB Transmitter and Balanced-T Antenna, Nautel FA 9782/1.	EA		
5	MSNR (25115B)	Battery, Maintenance Free, 80 AH, 12 1/2" X 6 3/4" X 8 3/4", Gould MF-27F	EA		
6	MSNR (25116C)	Batter/ Charger, 120/240 V AC Single Phase Input, 10 Ampere 48V Output, Equipped With Ac Circuit Breaker and Ac Power Failure Relay, LeBarche A-46-10-48V.	EA		

EDITION OF 1 AUG 73 IS OBSOLETE

DA FORM 3071-R
1 APR 78

Figure 5-1. Sample Bill of Materials (sheet 1 of 15).

15 November 1979

SEIP 013

LOCATION		TELECOMMUNICATIONS DEVELOPMENT PROJECT - BILL OF MATERIALS		UNIT IDENT CODE	
SEIP 013		Est. use of this form, see AIC 100-42; the procuring agency is the United States Army Communications Command.		DATE	PAGE NO. OF PAGES
TELECOMMUNICATIONS DEVELOPMENT PROJECT - BILL OF MATERIALS		UNIT IDENT CODE		DATE	PAGE NO. OF PAGES
NONDIRECTIONAL BEACON FACILITY		NOMENCLATURE		UNIT	TOTAL AVAILABLE PROJECT COMMAND REQUIRED
ITEM NO.	STOCK NUMBER	NOMENCLATURE		UNIT	TOTAL AVAILABLE PROJECT COMMAND REQUIRED
7	NSNR (25120M)	Beacon Transmitter Changeover Unit, F/U/W Two Nautel FA 9782 Transmitters, Nautel MAX-9.		EA	
8	NSNR (25142M)	Block, Terminal, 6 Pair Protected w/1304, Reliable W1-6P.		EA	
9	5975-CO-935-7677 (C6343P)	Box, Cable Terminal, Indoor, 5" W X 14" L X 2 1/2" D, w/Hinged Cover, Reliable 5600.		EA	
10	NSNR (25113Z)	Converter, +48V Dc, Btkor Corp. DDU 4807.		EA	
11	NSNR	Receiver, Monitor Alarm, LF/MF, 200 to 535 KHz (Receiver Presently Being Procured Under Contract - Details and SML Number to be Provided Later).		EA	
12	NSNR (25119F)	Shalter, Equipment, Molded Reinforced Fiberglass, 9' 3" H X 8' W X 10' L; Equipped with Circuit Breaker Panel with 100-Ampere Main and 8-15 Ampere Circuit Breakers, 1 1/2" LB Power Entrance, Four 100-Watt Incandescent Lights with Switch, Four Duplex Outlets, Exterior Light with Switch, 850 Cubic-Foot-Per-Minute, 12-Inch Exhaust Fan and Motorized Louvers, 12 Cable Entries, 2 1/2' X 4' Work Bench, 2'8" W X 6'0" H Door, Four 5" X 5" X 1/4" Shelter Tie-Down Plates, Fiberglass Repair Kit (Grassis FRK-065); GSA Type GS-085-33473, Grassis Corp. ES810-8.		EA	
13	NSNR	Signaling System, EDM Inband Consisting of: Common Module, Wescom 451 (19931J) Signaling Module, Wescom 452-FWA (19928G) Apertus Case, Wescom 12A Equipped with Mescom 400-2 Mounting Assembly (25296M).		EA	

EDITION OF 1 AUG 73 IS OBSOLETE

DA FORM 3071-R
1 APR 78

Figure 5-1. Sample Bill of Materials (sheet 2 of 15).

LOCATION		TELECOMMUNICATIONS DEVELOPMENT PROJECT - BILL OF MATERIALS		UNIT IDENT CODE	
SEIP 013		For use of this form, see AR 155-22, the procurement agency in the United States Army Communications Command.			
TELECOMMUNICATIONS DEVELOPMENT PROJECT - BILL OF MATERIALS		NONDIRECTIONAL BEACON FACILITY		UNIT IDENT CODE	
ITEM NO.	STOCK NUMBER	NOMENCLATURE	UNIT	TOTAL AVAILABLE REQ FOR PROJECT COMMAND	PAGE NO. IN COMMAND
14	NSRR (25121L)	Transmitter, Nondirectional Beacon, 50-Watt, Solid State, 190-553 KHz, Nautel FA 9782.	EA	3	5
15	4030-00-188-0535 (00047C)	Anchor, Guy, Rock Expanding Type, 8" Dia, 135 Sq In Open, Steel Asphalt Finish.	EA		
16	NSRR	Audible Alarm Unit, Sonalert, Mallory SC110M.	EA		
17	5306-00-407-6405 (004088)	Bolt, Eye, Standard Oval, 1/2" - 13 X 10.5" Long W/Sq Nut Hot Galv Steel, Thread Length 6 In.	EA		
18	5306-00-546-6809 (00441A)	Bolt, Angle, Eye, Standard Oval 5/8" - 11 X 12" Lg W/Sq Nut, Hot Galv Steel.	EA		
19	5306-00-402-5747 (09115M)	Bolt, Lag, 1/4" X 1-1/2".	EA		
20	5306-00-543-4405 (11115E)	Bolt, Mach, Hex Hd, 5/16" X 1" Lg, Steel.	EA		
21	5306-00-834-3939 (19544L)	Bolt, Mach, Hex Hd 1/4" - 20 X 7/8" Lg.	HD		
22	5306-00-297-8715 (08394X)	Bolt, Mach, Hex Hd, 5/16" X 1 1/4" Steel.	EA		
23	5306-00-309-1360 (08356Z)	Bolt, U, Rd 5/16 - 18 X 2.688" Lg W/Nuts.	EA		
24	5975-00-081-9401 (07708H)	Box Connector, 1/2" Steel, Insulated, Raintight, T&B 5123.	EA		
25	5975-01-019-0468 (10180Y)	Box, Junction, 12 X 12 X 4, Flat Cover, Square D, PN-12124B.	EA		

EDITION OF 1 AUG 72 IS OBSOLETE.

DA FORM 1 APR 78 3071-R

Figure 5-1. Sample Bill of Materials (sheet 3 of 15).

LOCATION		TELECOMMUNICATIONS DEVELOPMENT PROJECT - BILL OF MATERIALS		UNIT IDENT CODE	
SEIP 013		Per use of this form, use AR 100-2, the PROVISIONS POLICY is the United States Army Communication Command.			
TELECOMMUNICATIONS DEVELOPMENT PROJECT - BILL OF MATERIALS		NON-DIRECTIONAL BEACON FACILITY		DATE	
ITEM NO.	STOCK NUMBER	NOMENCLATURE	UNIT	TOTAL AVAILABLE PROJECT COMMAND	REQUIRE
26	NSNR (21646K)	Bushing, Anti-Snort, 1/2" Plastic, T&B NR 393.	EA	4	15
27	5975-00-962-9982 (11040N)	Bushing, Conduit, 3/4" Plastic.	EA		
28	NSNR (25237C)	Cable, Battery, 1 Gage, 12" Long, Beiden P/N 71241.	EA		
29	6145-00-933-7283 (12314E)	Cable, 6 Pair, Direct Burial, 22 AWG.	FT		
30	6145-00-542-6092 (03623D)	Cable, RG 58C/U 50 Ohm, Coax, 21 AWG Stranded.	FT		
31	NSNR (05111K)	Cable, RF, 1/2 Inch Jacketed Foamflex, Phelps Dodge FX 12-50H.	FT		
32	6145-00-543-0307 (03735D)	Cable, Shielded Cond., 1 Pr, 22 AWG, Stranded, Bare Wire.	FT		
33	5975-00-565-6630 (09677K)	Cable Tie, 3-1/2 In Max, Black, Nylon, 0.301" W X 13.38" L, Range 0.188" to 3.5".	HD		
34	7125-00-116-3881 (20846B)	Channel, Cont. Slot, 1 5/8" X 1 5/8" X 20', Unistrut.	LG		
35	NSNR (14103K)	Clamp, Conduit, 1", 1 Hole, Appleton P/N 17152.	EA		
36	5975-00-333-0949 (06265N)	Clamp, Short Bail, CLV, Dead End Clamp, Accommodates 0.3125 In Dia Strand.	EA		
37	5939-00-186-3912 (02391P)	Clamp, Electrical, 2 to 8 AWG Wire, 5/8" Rod, Sq Hd Bolt Type.	EA		

EDITION OF 1 AUG 73 IS OBSOLETE.

DA FORM 1 APR 75 3971-R

Figure 5-1. Sample Bill of Materials (sheet 4 of 15).

LOCATION		SEIP 013		TELECOMMUNICATIONS DEVELOPMENT PROJECT - BILL OF MATERIALS		UNIT IDENT CODE	
TELECOMMUNICATIONS DEVELOPMENT PROJECT - BILL OF MATERIALS		For use of this form, see AR 105-22, the proponent agency is the United States Army Communications Command.		NON-DIRECTIONAL BEACON FACILITY		DATE	
TELECOMMUNICATIONS DEVELOPMENT PROJECT - BILL OF MATERIALS		NON-DIRECTIONAL BEACON FACILITY		DATE		PAGE NO. 5	
TELECOMMUNICATIONS DEVELOPMENT PROJECT - BILL OF MATERIALS		NON-DIRECTIONAL BEACON FACILITY		DATE		TOTAL AVAILABLE PROJECT COMMAND 15	
ITEM NO.	STOCK NUMBER	NOMENCLATURE	UNIT	NO. OF PAGES REQUIRED			
38	5975-00-186-3976 (22737A)	Clamp, Electrical, 2-10 AWG Wire, 1/2" Rod.	EA				
39	5340-00-988-3210 (07727E)	Clamp, Cable, 0.250" ID, Nylon.	EA				
40	5340-00-978-7008 (25267Z)	Clamp, Pipe, 1/2" EMT, Unistrut PN P1426.	EA				
41	4030-00-233-9568 (00063L)	Clip, Wire Rope, 1/4" Dia U-Bolt Single Grip, Galv.	EA				
42	8030-00-273-8115 (08400M)	Compound, Sealing, Semisolid.	PT				
43	5975-00-178-1216 (02375J)	Conduit, Metal, Rigid, 1/2" EMT, 10 Ft Length.	LG				
44	5975-00-228-6004 (02446D)	Conduit, Metal, Rigid, 3/4" Thickwall, 10 Ft Length.	LG				
45	5975-00-228-0040 (02444B)	Conduit, Metal, Rigid, 1" Thickwall, 10 Ft Length.	LG				
46	5975-00-178-1209 (02373L)	Conduit, Metal, Rigid, 1 1/2" Thickwall, 10 Ft Length.	LG				
47	5975-00-152-1130 (02353I)	Coupling, Conduit, Rigid 1".	EA				
48	5975-00-179-0096 (02384L)	Coupling, Conduit, Thinwall 1/2".	EA				
49	5975-00-159-0969 (02370Y)	Cover, Conduit Outlet, 1/2", Form 7, Blank Type.	EA				

DA FORM 1 APR 78 3071-R EDITION OF 1 AUG 72 IS OBSOLETE.

Figure 5-1. Sample Bill of Materials (sheet 5 of 15).

LOCATION		TELECOMMUNICATIONS DEVELOPMENT PROJECT - BILL OF MATERIALS		UNIT IDENT CODE	
SEIP 013		For use of this form, see DA Form 10-22, the Procurement Policy of the United States Army Communications Command		DATE	PAGE NO
TELER NUMBER		NONDIRECTIONAL BEACON FACILITY		UNIT	NO. OF PAGES
ITEM NO.	STOCK NUMBER	NOMENCLATURE		TOTAL PROJECT REQUIRED	AVAILABLE COMMAND
50	5975-00-281-0056 (02311C)	Cover, Junction Box 4 X 4, Blank.		EA	6
51	5961-00-880-2938 (25266J)	Diode, Rectifier, General Purpose, 1A, 200 PRV, 1N4003.		EA	15
52	3439-00-260-1264 (00010J)	Flux, Soldering, Non-Corrosive Paste U/W Tin Lead Solder, 2 Oz Metal Can.		CN	
53	5920-00-199-9235 (25265K)	Fuse Holder, In-Line, Littlefuse 155020.		EA	
54	5920-00-280-5062 (25281Q)	Fuse, 3AG, Normal, 2A, Littlefuse 312002.		EA	
55	5325-00-275-5954 (07430K)	Grommet, Rubber 1-3/8" OD X 3/4" ID X 1/8" Thk.		EA	
56	5325-00-276-6229 (10557H)	Grommet, Rubber 3/4" OD X 9/16" ID X 1/8" Thk.		EA	
57	5975-00-263-1082 (02497Z)	Holder, Pole Step, Hot Galvs Steel Plate 1/4" X 4", Lag Screw Furnished.		EA	
58	5970-00-405-8791 (02267A)	Insulator, Feed Thru Bowl Type, Double Bowl, W/Gasket, 4-5/8" Dia.		EA	
59	5970-00-198-9809 (02234A)	Insulator, Stand Off Cyl Shape, Mt1 Base and Cap, 10" L X 1-1/4 Dia, Ceramic.		EA	
60	5970-00-356-0574 (02262N)	Insulator, Strain, Rect Shp, 3-1/4" Lg X 2-5/8" W X 2-5/8" Thk Porc.		EA	
61	5970-00-892-3643 (02288Z)	Insulator, Strain, Rect Shp, 12" X 1-1/2" Wd X 1" Thk, Ceramic		EA	

EDITION OF 1 AUG 75 IS OBSOLETE.

DA FORM 1 APR 78 3071-R

Figure 5-1. Sample Bill of Materials (sheet 6 of 15).

LOCATION		UNIT IDENT CODE	
SEIP 013		7	
TELECOMMUNICATIONS DEVELOPMENT PROJECT - BILL OF MATERIALS			
For use of this form, see AR 165-22; the paragraph number is the United States Army Communications Command.			
TELE NUMBER		DATE	
NONDIRECTIONAL BEACON FACILITY		5	
ITEM NO.	STOCK NUMBER	NOMENCLATURE	UNIT
62	5975-00-153-6398 (02365Z)	Junction Box, 4" X 4" X 1-1/2" Deep W/Eight 1/2" + Four 3/4" KO.	EA
63	5340-00-640-3996 (10012B)	Kit, Strapping and Sealing.	EA
64	NSNR (25283M)	Lamp Assembly, Dual, Tellite, 90EA2C2-F3J1(R)LI-NI.	EA
65	6240-00-538-8691 (22663C)	Lamp, Incandescent 100 Watts.	EA
66	6210-00-283-9738 (11055Z)	Lens, Light, Red, Fresnel Face, Marker Arcft Obstruction.	EA
67	6210-00-299-4608 (11054J)	Light, Marker, Arcft Obstruction, Crouse Hinds KL6198/AN-2547-4.	EA
68	5975-00-642-7261 (02820B)	Locknut, Elec Conduit, 3/4", 50/PG.	PG
69	NSNR (21312E)	Marker, Cable, A, 36/Card, T&B DPMCAS.	PG
70	NSNR (21313F)	Marker, Cable, D, 36/Card, T&B DPMWCS.	PG
71	NSNR (25242L)	Marker, Cable, G, 36/Card, T&B DPMWGS.	PG
72	NSNR (21314C)	Marker, Cable, P, 36/Card, T&B DPMWPS.	PG
73	NSNR (21311C)	Marker, Cable, S, 36/Card, T&B DPMWSS.	PG

DA FORM 1 APR 78 3071-R

EDITION OF 1 AUG 78 IS OBSOLETE

Figure 5-1. Sample Bill of Materials (sheet 7 of 15).

15 November 1979

SEIP 013

SECTION		TITLE		UNIT IDENT CODE	
SEIP 013		TELECOMMUNICATIONS DEVELOPMENT PROJECT - BILL OF MATERIALS		DATE	
NON-RECTIONAL BEACON FACILITY		for use of this form, see AH 100-22; the procurement policy is the United States Army Communications Command		PAGE NO. NO. OF PAGES	
STOCK NUMBER		NOMENCLATURE		TOTAL AVAILABLE FOR PROJECT COMMANDS	
ITEM NO.	STOCK NUMBER	NOMENCLATURE	UNIT	REQ FOR IN PROJECT COMMANDS	REQUIRED
74	NSNR (21315H)	Marker, Cable, 1-33, T&B DPWC1-33S.	PG		15
75	4730-CO-265-6904 (25107E)	Nipple, 1/2" X 2" Long, Thd Both Ends For Rigid Conduit.	EA		
76	4730-CO-196-2072 (25108F)	Nipple, 1" X 2" Long, Thd Both Ends For Rigid Conduit.	EA		
77	5310-CO-176-8162 (07433B)	Nut, Hex, 3/8-16, 5/8" Steel.	EA		
78	5310-CO-834-9762 (10675E)	Nut, Plain, Hex #8-32 Brass.	HD		
79	5310-00-550-2490 (07675L)	Nut, Plain, Hex, Steel, Cad. Pltd., 8-32.	EA		
80	5310-00-255-1650 (09558H)	Nut, Hex, 1/4 X 20, Steel, Cad Plated.	HD		
81	5310-00-890-7744 (07679A)	Nut, Plain, Hex, 5/16"-18.	HD		
82	5310-00-616-2793 (16983K)	Nut, Plain, Hex, 1/2" - 13.	EA		
83	5310-CO-915-4891 (07463Q)	Nut, Plain, Hex, 5/8"-11.	EA		
84	5975-CO-839-5320 (07209D)	Outlet, Conduit, Type T, 1/2" Thickwall, C-H T-17.	EA		

DA FORM 3071-R EDITION OF 1 AUG 72 IS OBSOLETE

Figure 5-1. Sample Bill of Materials (sheet 8 of 15).

LOCATION		TELECOMMUNICATIONS DEVELOPMENT PROJECT - BILL OF MATERIALS		UNIT IDENT CODE	
SEIP 013		For use of this form, see AFI 109-22, the recipient agency is the United States Army Communications Command.			
TELECOMMUNICATIONS DEVELOPMENT PROJECT - BILL OF MATERIALS		NON-DIRECTIONAL BEACON FACILITY		UNIT IDENT CODE	
ITEM NO.	STOCK NUMBER	NOMENCLATURE	UNIT	DATE	PAGE NO. OF PAGES REQUIRED
85	5975-00-060-8019 (07210Y)	Outlet, Conduit, Type LL, 1/2" Thickwall, C-H LL-17.	EA		9
86	5975-00-555-2776 (02642B)	Outlet, Conduit, Type LR, 1/2" Thickwall, C-H LR-17.	EA		15
87	5975-00-667-7474 (03010M)	Outlet, Conduit, Single Gang, For 1" Rigid Thickwall, 4.3 X 2.7 X 2.6, Crouse Hinds FDC-3.	EA		
88	NS/R (19746A)	Panel Screw, Grey, 10-32 X 3/4 In Lg, Phillips Drive.	HD		
89	5975-00-671-9351 (23067Z)	Panel, Blank, 19" X 1 3/4" X 1/8", Grey.	EA		
90	5975-00-686-2541 (08712Z)	Panel, Blank, 19" X 3 1/2" X 1/8", Grey.	EA		
91	5975-00-685-9791 (02406H)	Panel, Blank, 19" X 7" X 1/8", Grey.	EA		
92	NS/R (251060)	Photo Cell, Remote, 3-12 Footcandles, Mounted on DS Series Cover, Crouse Hinds DS60.	EA		
93	9515-00-204-3967 (08401L)	Plate, Steel, 5" X 0.1875".	FT		
94	9535-00-167-1964 (25253L)	Plate, Copper, 6' X 4" X 1/4" (Cut to size at depot).	FT		
95	5935-00-201-6655 (23282P)	Plug, Cannon MS 3106E14S-7P, 3 Pin.	EA		
96	5935-00-660-4296 (06832M)	Plug, Coaxial, N Type, RF UG 536 B/U.	EA		

DA FORM 1 APR 78 3071-R

EDITION OF 1 AUG 72 IS OBSOLETE.

Figure 5-1. Sample Bill of Materials (sheet 9 of 15).

LOCATION		TELECOMMUNICATIONS DEVELOPMENT PROJECT - BILL OF MATERIALS		UNIT IDENT CODE	
SEIP 013		NONDIRECTIONAL BEACON FACILITY		DATE	
TELE NUMBER		NOMECLAUTURE		PAGE NO. NO. OF PAGES	
STOCK NUMBER				10. TOTAL AVAILABLE REQ FOR IN PROJECT COMMAND	
ITEM NO.	STOCK NUMBER	NOMECLAUTURE	UNIT	TOTAL AVAILABLE REQ FOR IN PROJECT COMMAND	NO. OF PAGES
97	5510-00-161-2760 (00756D)	Pole, Line Construction, Wood, 45 Ft Class 2, Treated.	EA		15
98	5510-00-983-8811 (25114A)	Pole, Line Construction, Wood, 20 Ft Class 7, Treated.	EA		
99	NSNR (25264H)	Potentiometer, Dual, 250 Ohms, Allen Bradley JD1N200P251UA.	EA		
100	NSNR (25263Y)	Potentiometer, Dual, 2.5K Ohms, Allen Bradley JD1N200P252UA.	EA		
101	5975-01-010-6492 (03114Z)	Reducer, Conduit, 1" to 1/2", Crouse Hinds RE31.	EA		
102	NSNR (03112J)	Reducer, Conduit, 3/4" to 1/2", Crouse Hinds RE21.	EA		
103	5975-00-223-1852 (02421A)	Ring, Bridle, 1 5/8" Eye Size, 1 1/4" X 1/4" Shank, Steel, Galvanized, 10 per Package.	PG		
104	4030-00-243-6344 (11883C)	Rod, Anchor, Oval Eye Type 5/8" X 77" Long W/Washer & Nut.	EA		
105	5975-00-296-6324 (24567H)	Rod, Ground, 1/2" X 8', Copperweld.	EA		
106	5975-00-187-5292 (02394M)	Rod, Gnd, 5/8" X 6', Copper Plated, Conical Point.	EA		
107	5305-00-225-9091 (25265K)	Screw, Hex Head, Cap 5/16 X 1-1/4, MS90725-36.	EA		
108	5305-00-638-0502 (25265J)	Screw, Mach, Pan Head, 6-32 X 5/8" Lg.	HD		

DA FORM 1 APR 78 3071-R EDITION OF 1 AUG 72 IS OBSOLETE.

Figure 5-1. Sample Bill of Materials (sheet 10 of 15).

LOCATION		SEIP 013		UNIT IDENT CODE	
TELECOMMUNICATIONS DEVELOPMENT PROJECT - BILL OF MATERIALS					
For use of this form, see DA Form 3071-R, 1 APR 78, and the appropriate agency, if the United States Army, Communications Command					
TELE NUMBER		NON-DIRECTIONAL BEACON FACILITY		DATE	PAGE NO. OF PAGES
ITEM NO.	STOCK NUMBER	NOMENCLATURE	UNIT	TOTAL AVAILABLE REQ FOR PROJECT COMMAND	REQUIRED
109	5305-00-206-1285 (167963)	Screw, Mach, Pan Head, #8 - 32 X 3/4" Lg.	HD		
110	5305-00-984-6194 (218532)	Screw, Mach, Pan Head, Cad. Pltd, 8-32 X 5/8 In Lg.	HD		
111	5365-00-904-0262 (09109A)	Screw, Wood, RH8, 8 X 3/4 Round Head, Phillips Type.	GR		
112	5305-00-901-2602 (15321K)	Screw, Wood 12 X 1, Round Head, Phillips Type.	GR		
113	8030-00-149-1323 (223690)	Sealing Compound, Plastic Base, Putty, 5 Lb Pg.	PG		
114	5340-00-961-7304 (00704A)	Shield, Expansion, Anchor, 1/4" X 1 1/2".	HD		
115	3439-00-163-4347 (00002B)	Solder, 50/50 Bar Form, Lead Tin Alloy.	LB		
116	3439-00-184-9953 (00003C)	Solder, 50/50, Rosin Core, Wire Spool, 1 Lb.	LB		
117	5940-00-865-7528 (14455A)	Splice Connector, Split Bolt Type F/4 AWG, 5 Per Pg.	PG		
118	5315-00-161-9656 (00600F)	Staple, Fence 1/4" X 1-1/2" Lg.	LB		
119	9510-00-596-2029 (16917Z)	Steel, Bar, Cold Rolled, 1 1/4" X 3/8".	FT		

EDITION OF 1 AUG 78 IS OBSOLETE.

DA FORM 3071-R
1 APR 78

Figure 5-1. Sample Bill of Materials (sheet 11 of 15).

LOCATION		TELECOMMUNICATIONS DEVELOPMENT PROJECT - BILL OF MATERIALS		UNIT IDENT CODE	
SEIP 013		For use of this form, see AR 125-22, the present agency is the United States Army Communications Command.		DATE	PAGE NO. NO. OF PAGES
TELE NUMBER		NONDIRECTIONAL BEACON FACILITY		UNIT	TOTAL AVAILABLE REQ FOR PROJECT COMMANDS
ITEM NO.	STOCK NUMBER	NOMENCLATURE		UNIT	NO. OF PAGES REQUIRED
120	5975-00-407-6554 (02369F)	Step, Pole, Detachable, 5 1/2".		EA	
121	5975-00-260-3105 (02500C)	Step Pole, PF37 Hot Galvs, Std Hook 5/8" Dia X 10" Lg.		EA	
122	5975-00-339-0547 (07580X)	Strandwise, Long Bail, 1/4" Dia, U Bolt, Single Grip.		EA	
123	5340-00-924-1683 (12165J)	Strap, Retaining, 1 Hole, 1/2" EMT.		HD	
124	5940-00-188-8161 (22256Z)	Terminal, Battery Post, Medium Duty, 4 AMG - 2/0, 5/PG, Beiden P/N 7498.		PG	
125	NSNR (21720F)	Terminal Lug, #22-18 AMG, T-B RA1123.		EA	
126	5940-00-549-8075 (07452Y)	Terminal Lug, #2-8 AMG, 1/4".		EA	
127	NSNR (21715E)	Terminal Lug, #18-14 AMG, T-B RB864.		EA	
128	5940-00-159-1292 (08647A)	Terminal Lug, Solder Type, F/#12 AMG, Pg of 25.		PG	
129	NSNR (25258B)	Terminal Strip, Barrier, 4 Position Solder Terminals, Curtis 1504-ST.		EA	
130	4030-00-493-8071 (00068Z)	Thimble, Rope, Steel, 3/8" Dia, 7/8" Inside Wd, 1-7/8" Inside Lg.		EA	
131	7350-00-789-0095 (25110I)	Tray, Battery or Service, 14" X 18" X 7/8" Acid Resistant, Green, GSA.		EA	

DA FORM 1 APR 78 3071-R EDITION OF 1 AUG 72 IS OBSOLETE.

Figure 5-1. Sample Bill of Materials (sheet 12 of 15).

LOCATION		SEIP 013		TELECOMMUNICATIONS DEVELOPMENT PROJECT - BILL OF MATERIALS		UNIT IDENT CODE	
FOR USE OF THIS FORM, SEE AR 152-22, THE PROHIBITED LIST, IN THE UNITED STATES ARMY COMMUNICATIONS COMMAND.		AC/DIRECTIONAL BEACON FACILITY		DATE		PAGE NO. NO. OF PAGES	
TELE NUMBER		NOMENCLATURE		UNIT		TOTAL AVAILABLE FOR PROJECT COMMAND REQUIRED	
ITEM NO.	STOCK NUMBER						
132	5340-00-158-0335 (144568)	Turnbuckle, Assy, Open Buckle, Body Steel 11.312" X 19.5" With 9" Pull.	EA				
133	5310-00-846-5948 (25257A)	Unistrut Spring Nuts, 5/16, Pn - P1007.	EA				
134	5310-00-264-1369 (167020)	Washer, Flat, Rd Brass #8.	HD				
135	5310-00-167-0833 (00487C)	Washer, Flat, Steel, Cad. Pltd. No. 8, 0.164 ID - 0.370 OD.	HD				
136	5310-00-819-4698 (10293Y)	Washer, Flat, Rd, Stl, 0.266" ID X 0.50" OD.	EA				
137	5310-00-198-3642 (60516Z)	Washer, Flat, Round, .561" ID, .974" OD.	EA				
138	5310-00-371-2649 (14454Z)	Washer, Flat, Square, .687 ID, 2" OD, Steel.	EA				
139	NSNR (24036A)	Washer, Flat 7/16" ID, 1" OD, 5/64 Thick Cadmium Pltd. 67 Pieces Per Lb.	LB				
140	5310-00-639-1526 (09139K)	Washer, Flat, .328 ID, .8594" OD, Cadmium Pltd.	EA				
141	5310-00-889-2528 (25258H)	Washer, Lock Int & Ext Teeth 1/4".	HD				
142	5310-00-905-5159 (16703E)	Washer, Lock Int & Ext Teeth #8.	HD				
143	5310-00-889-3770 (09021X)	Washer, Lock, Split, Steel, Cad Pltd, #8.	HD				

DA FORM 1 APR 78 3071-R EDITION OF 1 AUG 72 IS OBSOLETE.

Figure 5-1. Sample Bill of Materials (sheet 13 of 15).

LOCATION		TELECOMMUNICATIONS DEVELOPMENT PROJECT - BILL OF MATERIALS		UNIT IDENT CODE	
SEIP 013		FOR USE OF THIS FORM, SEE AR 100-22, THE JOBS NATIONAL ADVISORY & THE UNITED STATES ARMY COMMUNICATIONS COMMAND		DATE	
TELE NUMBER		NON-DIRECTIONAL BEACON FACILITY		PAGE NO. NO. OF PAGES	
ITEM NO.		STOCK NUMBER		14 TOTAL AVAILABLE IN PROJECT COMMAND	
		NOMENCLATURE		15	
				TOTAL REQUIRED FOR PROJECT COMMAND	
144	5310-00-045-3299 (09019U)	Washer, Lock, Split, Steel, Cad. Pltd, No. 8, 0.16810 ID - 0.293 OD.	HD		
145	5310-00-407-9566 (00559H)	Washer, Lock .318 ID .586 OD, Cadmium Pltd.	HD		
146	5310-00-198-3745 (00521D)	Washer, Lock .312 ID, .394 OD, Zinc Pltd.	EA		
147	6145-00-129-9320 (0338CQ)	Wire, Bare, 6 AWG, Solid Soft Copper, 80 Lbs Per 1000 Ft.	LB		
148	6145-00-160-7148 (03425D)	Wire, Bare, 6 AWG, 7 Strand, Silicone Bronze Alloy.	FT		
149	6145-00-229-5832 (14677C)	Wire, Copper Bare, 2 AWG, Solid.	FT		
150	6145-00-122-8685 (03349C)	Wire, Elec, Bare #6 AWG (Ground), Solid.	FT		
151	MSAR (21653E)	Wire, Elec, #4 AWG, Yellow, Stranded, Tw.	FT		
152	MSAR (05005Z)	Wire, Elec, #8 AWG, Yellow, Stranded, Tw.	FT		
153	6145-00-191-2575 (03538G)	Wire, Elec, 10 AWG, Blk Solid.	FT		
154	6145-00-184-5346 (03507W)	Wire, Elec, 10 AWG, Wht Solid.	FT		
155	MSAR (09074N)	Wire, Elec, #12 AWG Yellow, Stranded, Tw, Anixter 68-1201 Yellow	FT		

DA FORM 1 APR 78 3071-R

EDITION OF 1 AUG 72 IS OBSOLETE.

Figure 5-1. Sample Bill of Materials (sheet 14 of 15).

LOCATION		TELECOMMUNICATIONS DEVELOPMENT PROJECT - BILL OF MATERIALS		UNIT IDENT CODE	
SEIP 013		For use of this form, see AR 15-22. The procuring agency is the United States Army, Communications Command.		DATE	PAGE NO. / NO. OF PAGES
TELE NUMBER		NONDIRECTIONAL BEACON FACILITY		UNIT	TOTAL AVAILABLE REQ FOR PROJECT COMMAND
ITEM NO.	STOCK NUMBER	NOMENCLATURE		UNIT	TOTAL AVAILABLE REQ FOR PROJECT COMMAND
155	6145-00-194-5341 (035056)	Wire, Elec, 14 AWG, Blk Stranded.		FT	
157	6145-00-652-3278 (07461Q)	Wire, Elec, 14 AWG, White Stranded.		FT	
158	6145-00-043-1255 (19525Z)	Wire, Elec, 14 AWG, Grn Stranded.		FT	
159	6145-00-726-6931 (238150)	Wire, Elec, Tw, Stran, 18 AWG, Green.		FT	
160	NSNR (23192P)	Wire, Elec, Tw, Stran, 18 AWG, White.		FT	
161	6145-00-224-9130 (23193Y)	Wire, Elec, Tw, Stran, 18 AWG, Black.		FT	
162	NSNR (16554C)	Wire, Elec, Tw, Stran, 20 AWG, Blue, Belden 8919-13.		FT	
163	4010-00-222-5344 (00026D)	Wire, Strand, 1/4" Galvs 1900 Lb Bking Str Type S, Class 2 Annealed.		FT	
164	4010-00-221-2708 (00023A)	Wire, Strand, Stl. 5/16" Dia Galv Steel 6,000 Lb Bking Str 1000 Ft per Reel.		RL	
165	NSNR (21644G)	Wire Nuts, Two #14 AWG Min, 2 #10 AWG & 1 #12 AWG Max, T&E PT-2B.		EA	

DA FORM 1 APR 78 3071-R EDITION OF 1 AUG 72 IS OBSOLETE.

Figure 5-1. Sample Bill of Materials (sheet 15 of 15).

SECTION 6. QUALITY ASSURANCE PROCEDURES.

6.1 GENERAL. The quality assurance (QA) program for the NDB has been developed in CCR 702-1-2. The QA program is to be implemented in accordance with this and the following two sections and will provide the assurance to all concerned that the specified equipment and facilities have been installed in accordance with the requirements and criteria of this SEIP as supplemented through individual engineering installation packages (EIP) and are acceptable for turnover to and use by the operating agency. The requirements and criteria specified here and in sections 7 and 8 constitute the quality assurance plan for the specified NDB. Individual EIPs will be used to supplement, expand, modify, or otherwise adapt the requirements and criteria to unique situations and circumstances applicable to each site location.

6.2 QUALITY ASSURANCE PROGRAM.

6.2.1 Approach. The QA program consists of a planned and systematic approach for assessing the quality during the installation and acceptance testing of project implementation and correcting at the earliest time any discrepancies, deficiencies, or shortcomings revealed through inspection and test efforts. The QA and quality control (QC) planning and functions will begin at the earliest stages of project implementation and end after all possible corrective action efforts are completed and the NDB is released to the operating or user agency. QA and QC functions are to be performed by personnel operating independently from those charged with the engineering of the installation or involved in the process of installing the NDB. Under the program, these functions are divided among three participating organizations: (1) the test agency, (2) the installation agency, and (3) the operating agency.

6.2.2 Test Agency. As the manager and implementor of the QA program and acceptance testing efforts for the NDB, the test agency will commence project planning as soon as tasked. The test agency quality assurance representative (QAR)/test director is responsible for periodic in-process QA checks, final QA inspections, and acceptance tests in accordance with management provisions of CCCR 702-3 and this SEIP. Quality assurance inspections will be performed at the discretion of this Agency for the purpose of assessing the effectiveness of the QC effort by the installation agency, initiating corrective actions as appropriate, and determining the extent to which the installation effort adheres to the quality requirements. Acceptance testing is conducted in accordance with section 7 and for the purpose of determining if the installed NDB complies with the technical requirements of this SEIP as amended

by individual EIPs and the NDB is suitable for the intended application. At the earliest stages of project initiation, the test agency is to identify a QAR/test director. For project continuity and effective management, a single individual should be assigned both roles. This will assure that the QA and test efforts are fully integrated and accomplished in the following manner and sequence to:

- a. Implement the QA concepts and requirements identified. Participate in the development of individual EIPs incorporating site particular requirements.
- b. Assure that the participating elements and organizations are thoroughly familiar with their respective roles in support of QA, QC, and testing and have been properly tasked.
- c. Validate QC and installation efforts for compliance with stated requirements through the use of project oriented reports, formal, and informal contacts, project status reviews, onsite inspections, etc. The installation agency's QC effort will be reviewed by the QAR utilizing USACEEIA Form 112 R (figure 6-2). When an inadequacy is found in the installation agency's QC effort, the procedures of CCR-702-7 will be applied. Followup actions will be monitored and those discrepancies or differences which cannot be resolved in a timely manner will be brought to the attention of higher authority.
- d. Facilitate responsibilities by identifying and recording this information and data as required by USACEEIA Form 113-R (figure 6-1). This form becomes a part of the project files and will be updated to assure orderly project execution. The dissemination of this information with the participants in the QA program is encouraged.
- e. Perform a final QA inspection using USACEEIA Form 111-R (figure 6-3), which is tailored to the specifics of this effort. When the installation effort and checkout of the NDB is performed, this SEIP, individual EIP, and the AFTO series shall be the evaluation criteria for the site inspection efforts. This inspection will consist of thorough visual and mechanical observations of the installed materiel, QC records, onsite inspection, and other factors to evaluate the quality of the work performed and its acceptability.
- f. Conduct acceptance tests in accordance with the provisions of section 7, the subsidiary documents specified, and CCCR 702-3, to determine the acceptability of the NDB, as installed. If the results of any portion of acceptance tests are not satisfactory, corrective action efforts are to be initiated through onsite engineering, installation, and operational participants and in the

absence of such representation, through channels. The QAR/test director may retest to verify that corrective action efforts have been implemented and that the efforts will preclude recurrence. After satisfactory resolution, he may subsequently resume acceptance tests. If these items cannot be resolved by onsite personnel, the QAR/test director will take either of the following actions: (1) reject the NDB and terminate testing until the matter is corrected or resolved, or (2) attempt to complete the acceptance tests, noting the discrepancies, deficiencies, or shortcomings as exceptions on the Technical Acceptance Recommendation (TAR), Form 98-R in section 8. The participating agencies and organizations will be notified of these discrepancies, deficiencies, and shortcomings at the earliest practical date.

g. Record and analyze test results; determine acceptability of the installed NDB; record the data and findings on the TAR and coordinate the data with the designated participants; and prepare a final test report and make distribution with the guidance, direction, and format of CCCR 702-2. Project tasking documents must be consulted for modification of the distribution requirements. The acceptance test report will note outstanding installation and operational exceptions, and will recommend corrective actions to be taken by the responsible and participating agency(s). The report will document project completion with correction of the exceptions being documented by correspondence or supplemental test reports as determined by the QAR/test director or test agency.

6.2.3 Installation Agency. In accordance with the provisions and authority of CCCR-702-4, the installation agency will establish and maintain a QC system. The QC system will assure that assessments of quality are conducted in accordance with the published procedures and that the results of the agency's QC inspections and follow-up actions are adequately recorded. USACEEIA Form 111-R (figure 6-3) will be used for this purpose. The records are to be made available for review and evaluation by the test agency's QAR/test director. The shakedown checkouts are to be completed and corrections made prior to offering the NDB for acceptance testing. The installation activity's QC system must meet all procedures contained in USACEI Bn Pamphlet 105-3. The installation agency will designate a quality control representative (QCR), who will assure that the following actions are performed.

a. Assure that QC procedures are applied on this installation and establish the reporting requirements consistent with this project, the EIP, and all policies. Assure that the corrective action efforts related to the installation are resolved and corrected at the earliest possible point in the installation effort.

15 November 1979

b. Assure the availability of test equipment for shakedown in conjunction with participating elements and checkout and acceptance testing. Reliance is to be placed upon the operating agency to supply test equipment when it is common to operations and maintenance functions.

c. Assure that shakedown is accomplished as specified and any corrective action is completed prior to acceptance testing.

d. Advise the QAR/test director of the anticipated completion date at the earliest time. This notice should be given not less than 10 days prior to the scheduled completion to permit efficient and expeditious transportation of test personnel and equipment.

e. Assure that an adequate complement of personnel remains onsite to assist in the final QA inspection and acceptance test.

f. Assure the QC inspection records and installation documentation are maintained onsite and readily available to the QAR/test director. When the onsite effort is completed, the QC documentation shall be placed in the project files and maintained for 1 year.

6.2.4 Operating Agency. The operating agency will be the site or location cognizant organization element and will be so identified in all project documentation and individual EIPs. Tasking to support the USACEEIA QA and acceptance test effort will be accomplished through command channels. The operating agency will designate a representative early in the project but no later than the start of installation. He will assure the following actions are taken and completed:

a. Provide administrative and typing support.

b. Serve as interface between the installation, quality assurance, and test personnel and the operating agency.

c. Assist in resolution of discrepancies, deficiencies, and shortcomings.

d. Make operating and maintenance personnel available to assist on an as-required basis.

e. Provide a representative to witness the acceptance test and sign the TAR.

6.3 SPECIAL CONSIDERATIONS.

6.3.1 Interruptions. Quality assurance inspections and tests may be interrupted at any point if disrupted by an equipment or system malfunction. They may also be interrupted at a compatible breaking point to permit scheduled duty breaks. Any inspection that is interrupted because of equipment malfunction shall be restarted at a point determined by the QAR/test director.

6.3.2 Substitutions. Spare equipment may be substituted for malfunctioning equipment with the approval of the QAR/test director. Any equipment which has been replaced shall be repaired and retested. During acceptance tests, any piece of equipment, including cables, conduit, etc., may not be changed or adjusted without the approval of the QAR/test director.

6.3.3 Corrections or Modifications of Documentation. Site plans, specifications, EIPs, drawings, etc., are to be acquired by QA, QC, and test personnel prior to commencement of the specified work effort. The QAR/test director will identify the applicable and non-applicable items on USACEEIA Form 112-R and will delete or mark "non-applicable" (N/A) those items inappropriate for this QA inspection. These documents shall be used as master documents to mark, record, and identify discrepancies. Any discrepancies noted shall be recorded, using yellow markings to record deletions of equipment, cables, or changes in schematic diagrams. All additions shall be noted with red markings. Notes to the draftsman shall be in blue. Site documentation will be marked in the same manner. The designated installation agency representative will deliver a copy of the marked-up drawings to the onsite USACEEIA installation engineering element and in the absence of an engineer to Commander, USACEEIA, ATTN: CCC-CED, Fort Huachuca, Arizona 85613 or as amended by the EIP. In all cases, a complete set of marked drawings will be left onsite and maintained by the operating agency.

COGNIZANT AGENCY, COMMAND, AND FACILITY QA POINTS OF CONTACT (CCCR 702-2)					
	<u>Individual POC</u>	<u>Bldg. No.</u>	<u>Rm. No.</u>	<u>Phone No.</u>	<u>Name of Agency</u>
<u>Installation:</u>					
Team Leader	_____	_____	_____	_____	_____
Assistant Team Leader	_____	_____	_____	_____	_____
Quality Control	_____	_____	_____	_____	_____
<u>Quality Assurance Agency:</u>					
Representative	_____	_____	_____	_____	_____
Testing Activity	_____	_____	_____	_____	_____
<u>Operating Agency:</u>					
Representative	_____	_____	_____	_____	_____
Site Commander	_____	_____	_____	_____	_____

HQ CEEIA CCC-TED-QA FM 113-R
1 JAN 79

Figure 6-1. QA Points of Contact.

15 November 1979

SEIP 013

QUALITY CHECKLIST - INSTALLATION (CCCR 702-2)		DATE (Day, Month, Year)		
SITE		LOCATION		
PROJECT NAME		TASK NO.		
REFERENCES FOLLOW MAIN AND SUB PARAGRAPHS				
A. <u>Drawings and Specifications</u> (AFTO 31-10-3, -9, -27, -29, USACEEIA PAM 105-10):				
		YES	NO	NA
1. Is the EIP complete and available?				
2. Are floor plans available?				
3. Are equipment location drawings available?				
4. Are face layout drawings of equipment in bays available?				
5. Are drawings for the MDF/CDF/IDF/CCFB block assignments available?				
6. Is stenciling of terminal blocks shown on drawings?				
7. Are pin connections on terminal blocks shown on drawings?				
8. Are drawings of AC/DC power distribution equipment available?				
9. Are wire sizes and circuit breaker capacity shown on drawings?				
10. Are schematic diagrams of typical circuits to be installed included in drawings?				
11. Are drawings of site grounding systems available?				
12. Do specifications contain a list of reference material required by installers?				
13. Are drawings showing the arrangement of cable racks, ducts, and trenches available?				

HQ CEEIA CCC-TED-QA FM 112-R
Rev (6 JAN 79) Previous edition 1 JAN 79 is obsolete.

Figure 6-2. Sample Quality Checklist - Installation (sheet 1 of 13).

QUALITY CHECKLIST - INSTALLATION (CCCR 702-2)			
	YES	NO	NA
14. Do specifications contain the cable running list for power distribution?			
15. Do specifications contain the cable running list for signal cabling?			
16. Do specifications contain the cable running list for RF cabling?			
17. Do specifications contain the cable running list for optical cabling?			
18. Do specifications contain detailed information on grounding/bonding/shielding?			
19. Do specifications contain details on all special instructions for installers?			
20. Do the drawings reference all applicable items to the BOM?			
B. Tools and Equipment (AFTO 31-10-29):			
1. Is equipment damaged or unserviceable?			
2. Are all installation materials on hand and serviceable?			
3. Are all special tools necessary for completion of the job on hand?			
4. Will all test equipment needed for test and checkout be available?			
5. Is the BOM equipment available at the facility?			
6. Is the C-E equipment BOM available at the facility?			
7. Has the C-E equipment been inventoried and are discrepancies reported (2-13)?			
C. General Safety Practice (AFTO 31-10-all):			
1. Are goggles worn when drilling and grinding?			

Figure 6-2. Sample Quality Checklist - Installation (sheet 2 of 13).

QUALITY CHECKLIST - INSTALLATION (CCCR 702-2)			
	YES	NO	NA
2. Are all sharp edges properly disposed of?			
3. Are hand tools properly used?			
4. Are electric tools properly grounded?			
5. Are rubber gloves used when working near electrical hazards?			
6. Is first-aid equipment on site?			
7. Are emergency numbers posted conspicuously?			
8. Are safety practices observed during the installation?			
D. Floor Plan Layout (AFTO 31-1J-9):			
1. Are equipment layout plans in accordance with drawings?			
2. Was the layout plan completed before equipment was moved into area?			
3. Are reference lines still visible/useable (2-11)?			
E. Erecting and Mounting (AFTO 31-10-29):			
1. Is equipment laid out in accordance with floor plan drawing (2-10)?			
2. Are equipment bays level and plumb within tolerances (2-42)?			
3. Has proper spacing been provided between equipment racks (2-36)?			
4. Are base angles of frames secured to floor in the proper location (2-48)?			
5. Are all cabinets flush mounted and plumbed (2-36)?			
6. Has the finish of equipment/cabinets/racks been touched up (3-2a)?			

Figure 6-2. Sample Quality Checklist - Installation (sheet 3 of 13).

QUALITY CHECKLIST - INSTALLATION (CCCR 702-2)			
	YES	NO	NA
7. Are bolts and screws free from stripped threads and defaced heads (3-3f)?			
8. Are sufficient clearances provided between apparatus for heat dissipation (3-11)?			
9. Are terminal blocks aligned on MDF/CDF/IDF (3-23)?			
10. Has equipment been installed in cabinets or racks in accordance with face layouts?			
11. Are all nuts and bolts securely tightened (3-3h)?			
12. Are exposed or cut ends of metal filed smooth and painted?			
13. Are the correct lock and flat washers used (3-3a, e, and f)?			
F. Cable Racks (AFTO 31-10-6):			
1. Location of cable racks:			
a. Are racks located in accordance with the cable plan drawing (3-17)?			
b. Does the height of racks conform to the drawing (3-13)?			
c. Are racks located so that clearances for installation and maintenance of equipment are unencumbered (3-14)?			
d. Are racks located so cables are not subject to damage, exposure, or other detrimental conditions (3-36a)?			
2. Assembly of cable racks:			
a. Are long sections of racks used where possible (3-3b)?			
b. Have clamping details been altered other than where necessary to avoid interference?			

Figure 6-2. Sample Quality Checklist - Installation (sheet 4 of 13).

QUALITY CHECKLIST - INSTALLATION (CCCR 702-2)			
	YES	NO	NA
c. Are open ends of racks properly closed (3-34)?			
d. Are vertical racks properly terminated on floors (3-36h)?			
3. Support of cable racks:			
a. Are racks properly supported and fastened (3-36b)?			
b. Are racks installed so that no excessive load or binding is imposed on the equipment (3-36e)?			
c. Are horizontal racks supported on 5' centers but not exceeding 6' (1-16)?			
d. Has support been provided within 3' of free end of rack (1-16)?			
e. Are racks braced to prevent sway (2-50)?			
f. Are racks level (3-33)?			
G. Running Cable (AFTO 31-10-13):			
1. Are cable runs made in accordance with cable running list (1-34)?			
2. Are cables twisted or crossed on cable rack (1-43)?			
3. Do cables at turns or bends conform to the bending radius and maintain their position (1-42)?			
4. Is protection provided where cable sheaths contact rough or sharp edges or metal (1-53)?			
5. Are cables, which are turned off over the side of cable racks, formed with the minimum allowable radius (1-42)?			
6. Are cables turned off rack horizontally and then up/down (1-42)?			
7. Do cables to the MDF/CDF/IDF enter on the vertical side (3-56)?			

Figure 6-2. Sample Quality Checklist - Installation (sheet 5 of 13).

QUALITY CHECKLIST - INSTALLATION (CCCR 702-2)			
	YES	NO	NA
8. Are cables serving the horizontal side of a frame secured to the transverse arms near the vertical upright (3-58)?			
9. Are cable tags properly prepared and in accordance with the cable running list (1-26)?			
10. Are cable tags secured at each end of the cable run (2-3)?			
11. Have cable tags been removed upon completion of verification and termination excluding coaxial cables (1-32)?			
12. Are cable butts located as near as practicable to the point where the first conductors turn out (4-8)?			
13. Are cable butts properly treated (4-9)?			
14. Is the cable pile-up exceeded (1-18)?			
15. Are the conductors damaged at the cable butt (4-9)?			
16. Are the AC/DC power cables separated for signal cables (1-49)?			
17. Are the correct color conductors used for power runs(AFTO 31-10-2,3-100)?			
H. <u>Securing Cable</u> (AFTO 31-10-2, -13)?			
1. Is the starting stitch properly made and placed (3-22)?			
2. Is the required Kansas City City Stitch properly made (3-26)?			
3. Are first and succeeding layers properly secured (3-28)?			
4. Are cables secured at every other cable rack cross strap on horizontal runs (3-21)?			

Figure 6-2. Sample Quality Checklist - Installation (sheet 6 of 13).

QUALITY CHECKLIST - INSTALLATION (CCCR 702-2)			
	YES	NO	NA
5. Are cables secured at every cable rack cross strap on vertical runs (3-53)?			
6. When cable butt is between securing devices, are cables secured together with the appropriate stitch (3-54)?			
7. Are lock stitches properly made and spaced (3-32)?			
8. Are splices in twine properly made (3-32)?			
9. Are cables protected where twine is apt to cut or damage cable (3-3)?			
10. Is the correct amount of cable secured under one stitch (3-16)?			
I. Sewed Forms (AFTO 31-10-2):			
1. Is proper size twine used for the diameter of the form (3-25)?			
2. Are the proper stitches used and spaced (3-26, 3-30)?			
3. Are wires formed correctly (3-49)?			
4. Are the skinnars the correct length (2-26)?			
5. When ty-wraps are used, are the correct size and spacing maintained (3-42)?			
6. Are spare wires treated correctly for the form (3-51)?			
J. Butting and Stripping (AFTO 31-10-13):			
1. Are the proper tools used (4-9, 4-15, 4-24)?			
2. Are the cable butts properly dressed (4-32, 4-34)?			
3. Is the proper distance maintained from the cable to the fanning strip (4-8)?			
4. Is the cable butt adequately supported (3-54)?			

Figure 6-2. Sample Quality Checklist - Installation (sheet 7 of 13).

QUALITY CHECKLIST - INSTALLATION (CCCR 702-2)			
	YES	NO	NA
5. Are the conductors damaged at the cable butt (4-9)?			
K. Fanned and Formed Conductors (AFTO 31-10-2):			
1. Are cables fanned and connected to the correct side of the terminal blocks (2-7)?			
2. Are the conductors in the fanned form twisted and bunched (2-14)?			
3. Are fanned forms straight and taut from the cable butt to the fanning strip (2-23)?			
4. Is the length of the skinners correct (2-26)?			
5. Has the correct color code been followed (2-28)?			
6. Are spare/unused/unequipped conductors disposed of properly (2-31)?			
7. Are the shields properly disposed of (3-79)?			
L. Stenciling (AFTO 31-10-27):			
1. Is equipment correctly identified and stenciled in accordance with floor plan drawings (1-24)?			
2. Are designations located correctly (2-16)?			
3. Are correct size designations used on particular types of apparatus or equipment (2-16)?			
4. Are the correct abbreviations used (3-3, 3-5)?			
M. Strapping (AFTO 31-10-16):			
1. Are the straps properly placed (1-15)?			
2. Is the correct type of strap wire used (1-17)?			
3. Does the insulation extend to the terminal (2-9)?			
4. Do the straps interfere with the operation of the equipment?			

Figure 6-2. Sample Quality Checklist - Installation (sheet 8 of 13).

AD-A078 204

ARMY COMMUNICATIONS-ELECTRONICS ENGINEERING INSTALLAT--ETC F/G 17/7
STANDARD ENGINEERING INSTALLATION PACKAGE. NONDIRECTIONAL BEACO--ETC(U)
NOV 79

UNCLASSIFIED

USACEEIA-SEIP-013

NL

2 OF 2
AD
A078204



END
DATE
FILMED
1-80
DDC

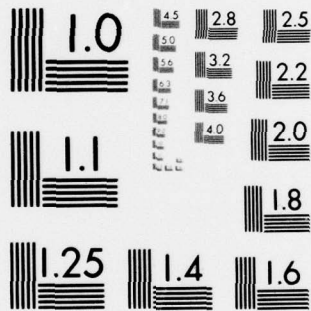

MICROCOPY RESOLUTION TEST CHART
NATIONAL BUREAU OF STANDARDS-1963-A

QUALITY CHECKLIST - INSTALLATION (CCCR 702-2)			
	YES	NO	NA
5. Do the straps make maximum contact with the terminals (2-6)?			
6. Do wrapped straps conform to the criteria of wrapped conductors (AFTO 31-10-1, 2-111)?			
7. Do straps obscure equipment designations (2-52f)?			
N. Terminating and Soldering Conductors (AFTO 31-10-7):			
1. Are the soldering clamp and solder bag used when connecting conductors (2-45a)?			
2. Is the proper soldering iron used (2-5)?			
3. Is all soldering done with the correct rosin core solder (2-22)?			
4. Is the conductor connected to the terminal correctly (2-34, 2-38)?			
5. Do skimmers on terminals, both wrapped and soldered, exceed 1/16" (2-34)?			
6. Is the insulation burnt, frayed, or otherwise damaged (2-34)?			
7. Have all unsightly flux and excess globules of solder been removed?			
8. Are the conductors given a continuity test after termination?			
9. Are wrapped connections applied only to suitable terminals (2-113)?			
10. Are mechanical connections making good contact, secure, and under no local stress (2-81)?			
11. Do pressure connections provide a good electrical connection (2-86)?			

Figure 6-2. Sample Quality Checklist - Installation (sheet 9 of 13).

QUALITY CHECKLIST - INSTALLATION (CCCR 702-2)			
	YES	NO	NA
12. Are the required number of turns in contact with the terminal in accordance with the gauge of wire used (2-120)?			
13. Are the conductors dressed on the terminal block after termination?			
14. Are wrapped connectors soldered where necessary (2-131f)?			
15. Do the wrap connections appear uniform with no open spirals, overwraps, or shiners exceeding 1/16" (2-131)?			
O. <u>Cross Connections</u> (AFTO 31-10-11):			
1. Are jumpers routed at the MDF/CDF/IDF correctly (2-6)?			
2. Is there sufficient slack remaining after termination (2-32)?			
3. Are conductors twisted between fanning strip and terminal (2-34)?			
4. Does the pair twist remain in conductors beyond the rear of the fanning strip (2-34)?			
5. Are jumpers properly dressed (2-54)?			
6. Are jumpers made in accordance with the cable running list?			
7. Is the correct gauge wire used?			
8. CCP's (USACEEIA PAM 105-10):			
a. Are sufficient jacks/plugs available for use with the CCP's (3-1)?			
b. Are jumpers made with 26 AWG wire only (3-1a)?			
c. Are modular tools available (3-2)?			

Figure 6-2. Sample Quality Checklist - Installation (sheet 10 of 13).

QUALITY CHECKLIST - INSTALLATION (CCCR 702-2)			
	YES	NO	NA
P. <u>Equipment and Signal Grounds</u> (AFTO 31-10-24, MIL-STD-188-24, TM 11-487-4):			
1. Are equipment and signal grounds installed in accordance with applicable drawings?			
2. Are the correct color coded cables used?			
3. Are grounds/bonds/shields protected from external corrosion?			
4. Are the correct screw/washer/nut combinations used on ground junctions?			
5. Are equipment/signal/protective grounds connected at the station ground box only?			
6. Are the signal grounds and signal buss insulated?			
Q. <u>Conduit</u> (AFTO 31-10-12):			
1. Are burrs removed from conduit after cutting (2-40)?			
2. Is the bending radius exceeded (2-55)?			
3. Are there more than 360 degrees of total bends in a single conduit run(2-46)?			
4. Does the number of conductors in a conduit exceed the established criteria (2-16)?			
5. Are conduits supported at intervals not exceeding 6' and within 3' of the end or outlet box (2-58)?			
6. Are flexible conduits terminated correctly (2-98)?			
7. Are all connections tight and secure?			
8. Are secure conduit runs correctly marked?			
R. <u>Metal Ducts</u> (AFTO 31-10-12):			
1. Are the ducting/raceways supported and anchored adequately (2-97, 3-10)?			

Figure 6-2. Sample Quality Checklist - Installation (sheet 11 of 13).

QUALITY CHECKLIST - INSTALLATION (CCCR 702-2)			
	YES	NO	NA
2. Is the percent of fill or voltage rating of the duct exceeding (3-5, 3-50)?			
3. Are junction boxes of underfloor raceway level and secure (-3-26)?			
4. Are all covers secured in place?			
5. Have all entrance/exit holes for outside ducting been properly sealed(2-23)?			
6. Is the red/black criteria observed?			
S. Coaxial Cables (AFTO 31-10-14):			
1. Is cable inspected for damage prior to termination?			
2. Where required, is cable sewn in the same manner as signal cable?			
3. Are the correct connectors on cable ends (2-6)?			
4. Are connections secure, free of excess solder, and electrically open (1-42, 1-55)?			
5. Are cable tags still connected to both ends of the RF cable (3-29)?			
6. Is the bending radius exceeded (1-73)?			
7. Are the cables properly supported (1-26, 3-21)?			
8. Are rigid cables properly grounded (1-46, 3-27)?			
9. Is the pressure maintained (1-75, 3-61)?			
T. Optical Fiber Cables (OFC):			
1. Are the OFC protected so that external conditions will not crush the fibers?			
2. Has adequate slack been provided for maintenance loops?			

Figure 6-2. Sample Quality Checklist - Installation (sheet 12 of 13).

QUALITY CHECKLIST - INSTALLATION (CCCR 702-2)			
	YES	NO	NA
3. Are the external strength members of the OFC properly served?			
4. Are the fibers properly terminated?			
U. Waveguides and Antennas (USACEEIA PAM 105-3):			
1. Are waveguides stored horizontally and away from heavy objects (7a)?			
2. Are waveguides inspected for damage and cleaned prior to installation (7a)?			
3. Are waveguides supported correctly (7a)?			
4. Are the feed horns aligned correctly?			
5. Do waveguide bends conform to the minimum radius (8b, 8e)?			
6. Are antennas/reflectors mounted at the prescribed heights?			
7. Are antennas/reflectors oriented to the correct azimuth?			
8. Are E and H plane benders on hand for elliptical waveguides?			
9. Are waveguides grounded correctly (7-6 (7))?			
<hr style="width: 50%; margin: 0 auto;"/> <p>QUALITY REPRESENTATIVE</p>			

Figure 6-2. Sample Quality Checklist - Installation (sheet 13 of 13).

QUALITY ASSURANCE/MIL-Q-9858A/ MIL-I-45208 PROGRAM CHECKLIST (CCCR 702-2)			DATE (Day, Month, Year)		
SITE/LOCATION		PROJECT NAME	QUALITY ASSURANCE REPRESENTATIVE (QAR)		
___ QA	___ MIL-Q-9858A	___ MIL-I-45208	TASK NO.		
			YES	NO	NA
1. Is the on-site inspection/quality program available for review?					
2. Does the inspection system/quality program address the pertinent requirements which will assure that all conditions are complied with?					
3. Are quality personnel and their responsibilities identified?					
4. Are detailed work instructions provided and complied with?					
5. Do records provide useful information, data, and indicate follow-up action?					
6. Are provisions made for prompt corrective actions when deficiencies occur?					
7. Are procedures provided and complied with for prevention and correction of defects?					
8. Are pertinent documents and drawings available?					
9. Are procedures provided and complied with for updating and controlling documents and drawings?					
10. Are procedures provided and complied with for storage of material prior to installation.					
11. Are in-process and final test and inspection procedures available and used?					
12. Is inspection system being complied with in all phases?					

HQ CEEIA CCC-TED-QA FM 111-R
 (Rev 1 Jan 79) Previous edition 6 DEC 78 is obsolete.

Figure 6-3. Sample Quality Assurance Checklist (sheet 1 of 2).

QUALITY ASSURANCE/MIL-Q-9858A/MIL-I-45208 PROGRAM CHECKLIST (CCCR 702-2)			
	YES	NO	NA
13. Are procedures provided for control of subcontractor's work?			
14. Are procedures provided for calibration and controlling of test equipment?			
15. Are procedures provided for handling, inspection, and test of furnished material?			
NOTE: IF THE "NO" COLUMN IS CHECKED, EXPLAIN HERE, AND CONTINUE ON REVERSE SIDE IF NEEDED.			

Figure 6-3. Sample Quality Assurance Checklist (sheet 2 of 2).

SECTION 7. OPERATIONAL TEST PLAN AND CHECKOUT PROCEDURES

7.1 GENERAL. This section contains the test procedures and states the special conditions which apply to shakedown, checkout, and acceptance tests for the installed NDB. Onsite tests are performed to determine if the designated NDB has been installed correctly, performs in accordance with the technical requirements of this SEIP and subsidiary documents, and is operationally suitable for the intended application.

7.2 TESTING.

7.2.1 Shakedown Test and Checkout. Functional tests will be conducted by the installation agency for the purpose of assuring that the equipment is aligned and operable and the installation is in accordance with the engineering documentation. These tests and checkouts will be conducted in coordination with personnel of the operating agency using the test plan identified in paragraph 7.2.2 and applicable technical bulletins and technical manuals available to the operating agency (the user). These tests will be conducted prior to the installation agency offering the installation for acceptance tests. As stated in section 6, the installation agency is to anticipate the installation completion date and notify the test agency of this completion not less than 10 days before the scheduled installation completion date.

7.2.2 Onsite Acceptance Tests. Onsite acceptance testing will be accomplished in accordance with USACEEIA technical publication number CCC-TED-75-TP-200. These tests will be preceded by a thorough QA inspection in accordance with the requirements of section 6. Tests will be conducted in a normal operating environment, as stated in TB 95-1. Abnormal ambient conditions (e.g., temperature, humidity, or barometric pressure) during any test will be noted in the test log with detailed remarks included with the test results. The test director will determine if any retesting is required. The operating agency will provide personnel to operate and maintain the equipment during tests. Installation agency will provide personnel to assist the test director in the conduct of tests and measurements.

7.2.3 Flight Checks. Operational flight checks will be performed by Federal Aviation Administration (FAA) qualified Air Traffic Control (ATC) personnel in conjunction with the acceptance tests and under the direction of the test director. Flight checks will determine whether or not the installed NDB functions correctly and performs in accordance with individual equipment and system mission requirements. This flight check is documented by the FAA. Copies of this report will be furnished participating agencies and included in the test report and retained in project files.

7.2.4 Test Equipment. A complete listing of the required test equipment is contained in the technical manuals and approved test plan. Although the installation agency is responsible for assuring that the required complement of test equipment is available for installation, inspection, and test purposes, this test equipment should be available onsite from the operating agency.

7.2.5 Technical Acceptance Recommendation. Based on the QA inspections, QC reports and documentation, acceptance test results, and flight check results, the Test Director will determine the acceptability of the work effort. Prior to actual rejection, if the circumstances so warrant, the Test Director will attempt to coordinate his determination with the test agency and other cognizant agencies. The Test Director will prepare and distribute the technical acceptance recommendation (TAR) in accordance with the requirements of section 8. Preparation of the TAR will be accomplished onsite immediately following acceptance tests.

7.2.6 Test Results. When one or more tests fail to meet requirements, the test director will determine which portion(s) of the test was affected and which portion(s) of the equipment or facility is to be retested. All deficiencies will be corrected, or, if not corrected, the deficiencies will be reported on the TAR and in the final test report.

7.2.7 Final Test Report. The test agency will prepare and distribute a test report in accordance with CCCR 702-2 as amended by the individual EIP and tasking documents. Copies of the completed TAR and flight inspection report will be included.

SECTION 8. COMPLETION CERTIFICATION

8.1 GENERAL. The results of the QA inspections and acceptance tests specified in sections 6 and 7 will be documented on-site by the QAR/test director using USACEEIA Form 98-R, Technical Acceptance Recommendation (figure 8-1). The purpose of this technical document is to record the significant project information to include the scope of the effort, results and conclusions of the requisite inspections and tests, exceptions to the technical requirements, and recommendations regarding acceptance with or without exceptions or rejections of the work effort. The Technical Acceptance Recommendation (TAR) also allows other participants to indicate agreement or disagreement with the inspection and test assessments, and for the user to state a willingness to technically accept the installed NDB.

8.2 DISTRIBUTION. A copy of the TAR will be provided to the signing participants and the operating agency. The original copy will be maintained in the test agency project files, but copies will be reproduced and included as part of the test report.

8.3 WAIVERS. Waivers to include command approvals for individual installations will be recorded in the TAR and copies attached for the purpose of clarifying deviations from this SEIP, the individual EIP, and Technical Bulletin TB 95-1.

8.4 TAR PREPARATION INSTRUCTIONS.

a. Entries on the data sheets are to be typed whenever possible to ensure legibility and provide a quality, fully legible product when reproduced. If a typewriter is not available, the forms may be completed by printing with black ink in block letters to ensure legibility. The instructions for completion of this form follow on a block-by-block basis.

b. Pages are to be sequentially numbered to show both the individual page number and the total number of pages constituting the completed TAR. Additionally, each page will be identified by the date, project, and contract number in the appropriate blocks.

15 November 1979

c. Instructions for completion of the TAR are delineated in the following subparagraphs and will be completed in accordance with these instructions:

(1) DATE: Enter the day, month, and year of completion for this action (e.g., 1/1/79 as the first day of the first month of 1979).

(2) PROJECT/CONTRACT NUMBER: Enter the appropriate project or contract number. If this is a subproject or part of a sub-project, provide all necessary information (i.e., IIP milestone number(s) and subproject number(s), as well as subdivision(s) to same).

(3) TITLE: Enter the project name or title.

(4) LOCATION: Enter the geographic location where the project was installed.

(5) FACILITY: Enter the name of the facility and other pertinent identifying information.

(6) TEST DIRECTOR: Enter the name, title, and grade of the test director or QAR assigned to this project.

(7) OPERATING AGENCY: Enter the name, symbol, and complete mailing address of the organization having O&M responsibility for this project, system, or equipment installation.

(8) ENGINEERING AGENCY: Enter the name, symbol, and complete mailing address of the organization having engineering cognizance and responsibility.

(9) INSTALLATION AGENCY: Enter the name, symbol, and complete mailing address of the organization having been tasked to install the TAR materiel.

(10) TESTING AGENCY: Enter the name, symbol, and complete mailing address of the QA and testing organization tasked for this project.

(11) PROJECT DESCRIPTION: Enter a brief and concise description of the project to which the TAR applies.

(12) MAJOR EQUIPMENT INSTALLED/RELOCATED: List the major items of equipment installed or relocated in accordance with the project requirements. Enter the BOM line item number, materiel description, assigned part number or National Stock Number, and the quantity of each major item.

(13) DOCUMENTATION: Enter the document identification (i.e., drawing number, technical manual number, etc.), title, and the quantity of each document provided to the operating unit as part of the project.

(14) EXCEPTIONS:

(a) Upon completion of installation and testing, any exceptions to the project requirements that require corrective action will be listed. Include complete identification of each missing item. Exceptions must be based on the specified requirements of the project, supportable through the test results or other valid documentation, fully described, and precisely identified.

(b) The appropriate exception block must be annotated, and separate sheets should be used for each category of exception.

(c) The test director will also enter the suggested action agency for each exception, recognizing that the test director may not always be in a position to determine the final action agency.

(d) For facilities that are becoming partially operational, identify installation agency actions remaining for project completion. In this situation, the TAR will show the tests that have been made, but will be identified as a partial record. A final TAR will be prepared after installation and testing of all remaining project equipment.

(15) REMARKS: The REMARKS section may be used to provide any additional information on or in support of a recommendation, commendation, or criticism in relation to the project installation, engineering, or testing. Entries may include:

(a) Shortcomings that do not require corrective action (not considered an exception).

(b) Recommendations for improving projects of a similar nature.

(c) Identification of support items that have not been accomplished, and a description of any activity in progress by the operating agency to satisfy the requirement.

(d) A description of test results with the performing agency and date(s) accomplished.

(e) A statement to the effect that the installation agency will forward final "as-built" drawings when completed.

(f) A description of the ac power system with identification of source and backup capability.

(g) A statement to indicate that a list of excess material was provided the operating command for final disposition or to identify material that was excess to the project.

(16) CERTIFICATION: Enter the signatures and certification that the project was installed, tested, and accepted for operation with or without exceptions, as applicable.

15 November 1979

SEIP 013

TECHNICAL ACCEPTANCE RECOMMENDATION (SUMMARY) (CCCR 702-2)		PAGE OF PAGES
		DATE (DAY, MO, YEAR)
PROJECT/CONTRACT NO.	TITLE	LOCATION
FACILITY		TEST DIRECTOR
OPERATING AGENCY	ENGINEERING AGENCY	
INSTALLATION AGENCY	TESTING AGENCY	
PROJECT DESCRIPTION		
<p>This Technical Acceptance Recommendation is executed by the onsite representatives of the installation, test and operating agencies. It does not constitute official acceptance of the project but does certify that the MAJOR ITEMS INSTALLED AND DOCUMENTATION PROVIDED are as stated herein. This document further certifies that the project has been installed and performs satisfactorily in accordance with the requirements listed under REFERENCES except as noted under EXCEPTIONS and REMARKS. Upon execution of this TECHNICAL ACCEPTANCE RECOMMENDATION, USACE/IA considers this project complete except for such follow-on action as may be necessary to clear the EXCEPTIONS stated herein.</p>		

HQ CEEIA CCC-TED-QA FM 98-R
(Rev 1 Jan 79) Previous edition 27 Mar 78 is obsolete.

Figure 8-1. Sample Technical Acceptance Recommendation (sheet 1 of 6).

TECHNICAL ACCEPTANCE RECOMMENDATION (INSTALLED EQUIPMENT) (CCCR 702-2)		PAGE	OF	PAGES
		DATE (DAY, MO, YEAR)		
PROJECT/CONTRACT NUMBER	TITLE	LOCATION		
MAJOR EQUIPMENT INSTALLED/RELOCATED				
BOM ITEM NO.	DESCRIPTION	PART NUMBER/FSN	QUANTITY	

Figure 8-1. Sample Technical Acceptance Recommendation (sheet 2 of 6).

15 November 1979

SEIP 013

TECHNICAL ACCEPTANCE RECOMMENDATION (DOCUMENTATION) (CCCR 702.1)		PAGE OF PAGES
		DATE (DAY, MO, YEAR)
PROJECT/CONTRACT NUMBER	TITLE	LOCATION
PROJECT DOCUMENTATION PROVIDED		
REFERENCE DOCUMENTATION	TITLE	NO. OF COPIES

Figure 8-1. Sample Technical Acceptance Recommendation (sheet 3 of 6).

TECHNICAL ACCEPTANCE RECOMMENDATION (EXCEPTIONS) (CCR 702-2)			PAGE OF PAGES DATE (DAY, MO, YEAR)
PROJECT/CONTRACT NUMBER	TITLE	LOCATION	
EXCEPTIONS ENGINEERING INSTALLATION OTHER			SUGGESTED ACTION AGENCY

Figure 8-1. Sample Technical Acceptance Recommendation (sheet 4 of 6).

15 November 1979

SEIP 013

TECHNICAL ACCEPTANCE RECOMMENDATIONS (REMARKS) (CCCR 702-2)		PAGE OF PAGES
		DATE (DAY, MO, YEAR)
PROJECT/CONTRACT NUMBER	TITLE	LOCATION
<u>REMARKS:</u>		

Figure 8-1. Sample Technical Acceptance Recommendation (sheet 5 of 6).

TECHNICAL ACCEPTANCE RECOMMENDATION (CERTIFICATION)		PAGE OF PAGES
		DATE (DAY, MO, YEAR)
PROJECT/CONTRACT NUMBER	TITLE	LOCATION
CERTIFICATION Acceptance tests and Quality Assurance Inspections are complete for equipment installed under this project.		
WITHOUT EXCEPTIONS <input type="checkbox"/> WITH NOTED EXCEPTIONS <input type="checkbox"/>		
INSTALLATION AGENCY	SIGNATURE AND TITLE	
	PRINTED	
OPERATING AGENCY	SIGNATURE AND TITLE	
	PRINTED	
TEST AGENCY	SIGNATURE AND TITLE	
	PRINTED	
ACCEPTANCE Equipment herein certified successfully installed and tested, is accepted.		
OPERATING COMMAND	SIGNATURE	
	TITLE	

Figure 8-1. Sample Technical Acceptance Recommendation (sheet 6 of 6).

15 November 1979

SEIP 013

(CCC-CED)

FOR THE COMMANDER:

OFFICIAL:

R. K. BOWERS
Colonel, Signal Corps
Deputy Commander

Merton M. K. Chun

MERTON M. K. CHUN
Lieutenant Colonel, Signal Corps
Executive Officer

DISTRIBUTION:

Special

- 5 - CC-PA-AMP
- 10 - CCC-CED-SEP
- 4 - CCC-CED-SW
- 4 - CCC-TED
- 5 - USACEI Bn
- 10 - USACEEIA-CONUS, ATTN: CCCN-TR, Fort Ritchie, MD 21719
- 10 - USACEEIA-EUR, APO New York 09056
- 10 - US Army Signal School, ATTN: ATSN-CD-MS, Fort Gordon, GA 31905
- 2 - US Army Materiel Development and Readiness Command, ATTN: CCN-PI-P, Washington, DC 20315
- 5 - 5th Signal Command, APO New York 09056
- 5 - 7th Signal Command, Fort Ritchie, MD 21719
- 3 - US Army Communications Command, ATTN: CC-OPS-PT, Fort Huachuca, AZ 85613
- 2 - US Army Training and Doctrine Command, ATTN: ATCE, Fort Monroe, VA 23351
- 2 - US Army Forces Command, ATTN: AFCE, Fort McPherson, GA 30330
- 2 - Defense Communications Agency, Technical Library Center, Code 205, Washington, DC 20305
- 12 - Defense Documentation Center, Cameron Station, Alexandria, VA 22314
- 2 - Keesler Technical Training Group, 3395th Tech. Trng. Gp., ATTN: TTE00A, Keesler AFB, MS 39534
- 2 - 1842 EEG (AFCS), ATTN: EEM, Scott AFB, IL 62225
- 2 - Naval Electronic Systems Command (NAVELEX), Code 51032, Washington, DC 20315

SEIP 013

15 November 1979

DISTRIBUTION (Continued)

- 4 - 1st Signal Brigade, USACC-Korea, ATTN: CCK-OPS, APO
San Francisco 96218
- 1 - USACC-Agency-Japan. ATTN: CCJ-OPS, APO San Francisco
96343
- 2 - USACEEIA Installation Detachment-Korea ATTN: CCCK-IN/CCCK-QA
APO San Francisco 96301
- 2 - USACC-WESTCOM, Fort Shafter, HI 96851

DEPARTMENT OF THE ARMY
US Army Communications-Electronics
Engineering Installation Agency
Fort Huachuca, Arizona 85613

OFFICIAL BUSINESS
PENALTY FOR PRIVATE USE \$300

POSTAGE AND FEES PAID
DEPARTMENT OF THE ARMY
DoD 314



COMMANDER
US ARMY COMMUNICATIONS-ELECTRONICS
ENGINEERING INSTALLATION AGENCY
ATTN: CCC-CED-SEP
Fort Huachuca, Arizona 85613

DEPARTMENT OF THE ARMY
US Army Communications-Electronics
Engineering Installation Agency
Fort Huachuca, Arizona 85613

OFFICIAL BUSINESS
PENALTY FOR PRIVATE USE \$300

POSTAGE AND FEES PAID
DEPARTMENT OF THE ARMY
DoD 314



COMMANDER
US ARMY COMMUNICATIONS-ELECTRONICS
ENGINEERING INSTALLATION AGENCY
ATTN: CCC-CED-SEP
Fort Huachuca, Arizona 85613

This standard engineering installation package is based on the most current thinking at US Army Communications Command. Your experience and help can improve our responsiveness in this area. Please send us your comments. Thanks.

Comments on SEIP ____ (please give number)

SEIP MGT Officer
AUTOVON 879-6719

How can we contact you?

Rank	Name	Duty position	Duty station	AUTOVON number
------	------	---------------	--------------	----------------

This standard engineering installation package is based on the most current thinking at US Army Communications Command. Your experience and help can improve our responsiveness in this area. Please send us your comments. Thanks.

Comments on SEIP ____ (please give number)

SEIP MGT Officer
AUTOVON 879-6719

How can we contact you?

Rank	Name	Duty position	Duty station	AUTOVON number
------	------	---------------	--------------	----------------