

D-A078 333

ROYAL AIRCRAFT ESTABLISHMENT FARNBOROUGH (ENGLAND) F/G 20/4
A COMMENT ON THE ORIGIN OF ENDWALL INTERFERENCE IN WIND-TUNNEL --ETC(U)
AUG 79 K G WINTER, J H SMITH

UNCLASSIFIED

RAE-TM-AERO-1816

DRIC-BR-70172

NL

| OF |
AD
A078333

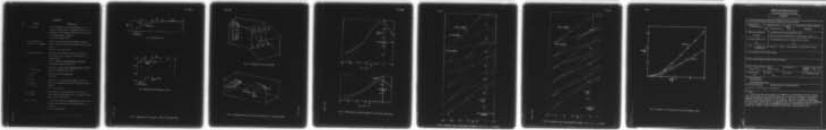

END
DATE
FILMED
1-80
DDC

(2) LEVEL II

ADA 078333

ROYAL AIRCRAFT ESTABLISHMENT

(9) Technical memo.

(6) A COMMENT ON THE ORIGIN OF ENDWALL INTERFERENCE
IN WIND-TUNNEL TESTS OF AEROFOILS.

by
(10) K. G. Winter
J. H. B. Smith

(11) August 1979

(12) 20

DDC
RECEIVED
NOV 13 1979
B

DDC FILE COPY

COPYRIGHT ©
1979
CONTROLLED
HMSO LONDON

79 11 09 116

UNLIMITED
310 450

JB

ROYAL AIRCRAFT ESTABLISHMENT

Technical Memorandum Aero 1816

Received for printing 20 August 1979

A COMMENT ON THE ORIGIN OF ENDWALL INTERFERENCE
IN WIND-TUNNEL TESTS OF AEROFOILS

by

K. G. Winter

J. H. B. Smith

SUMMARY

Tests have been made recently at ONERA on the interference effects arising from the presence of the boundary layers on the walls at the ends of an aerofoil spanning the working section of a wind tunnel. The tests revealed a behaviour different from that predicted by the theory of Preston. A qualitative assessment of the problem is made and it is suggested that the interference is better explained in terms of changes in the displacement thickness of the boundary layers on the tunnel walls than in terms of induced effects from trailing vorticity.

Copyright
©

Controller HMSO London
1979

ACCESSION for	
NTIS	White Section <input checked="" type="checkbox"/>
DDC	Buff Section <input type="checkbox"/>
UNANNOUNCED	<input type="checkbox"/>
JUSTIFICATION _____	
BY _____	
DISTRIBUTION/AVAILABILITY CODES	
Dist.	AVAIL. and/or SPECIAL
A	

1 INTRODUCTION

Recent developments in aerofoil design have led to a renewed interest in testing aerofoils in wind tunnels, and the need to provide data for assessing the accuracy of calculation methods has led to the re-examination of the interference effects due to the tunnel walls. One effect which occurs when an aerofoil spans a tunnel is caused by the presence of the boundary layers on the walls in which the ends of the aerofoil are immersed. In many facilities these boundary layers are removed by suction but this procedure is not always possible and a means of estimating the interference effect is desirable. The problem was considered by Preston¹ in 1944 and he produced a solution which gave good agreement (see Fig 1a) with measurements of the spanwise distribution of lift measured on an aerofoil spanning the NPL Duplex tunnel. However, the effects measured by Mendelsohn and Polhamus² in 1947 were considerably less than those predicted by Preston's theory (Fig 1b). In his theory Preston assumes that the local lift coefficient is constant through the boundary layer on the tunnel wall and that trailing vorticity is shed within the boundary layer with a spanwise distribution derived from the spanwise variation in circulation consequent upon the assumption of constant lift coefficient and varying onset velocity. With this assumption for a symmetrical aerofoil with a lift-curve slope of 2π an expression for the induced reduction of angle of incidence of the aerofoil at the tunnel centre-line is obtained as

$$\frac{\Delta\alpha}{\alpha} = \frac{2}{A} \frac{\delta^*}{b}$$

where α is the angle of incidence, A the aspect ratio of the aerofoil, $2b$ its span and δ^* the boundary-layer displacement thickness.

Recently a careful investigation of the interference effect of the sidewall boundary layers has been made at ONERA³, in a wind tunnel in which the boundary-layer thickness could be varied by the use of suction. Pressures measured round the centre section of an aerofoil spanning the tunnel were integrated to obtain the variation with angle of incidence of the normal and axial components of the pressure force and the pitching moment. The results showed that for both the variation of axial force and of pitching moment with lift all points fell on common lines independent of the boundary-layer thickness, so that the interference effect could be ascribed to changes in the effective angle of incidence. In subsequent analysis, unpublished, it was shown that the change in normal force coefficient could be expressed as

$$\frac{\Delta C_N}{C_N} = k \frac{\delta^*}{b}$$

over a range of values of δ^*/b from about 0.01 to 0.05. Tests were made on an uncambered aerofoil of aspect ratio 2/3 and two cambered aerofoils of aspect ratio 4/3 and 8/11. Provided the flow was subcritical k was found to have a value of about 1.5 for all three aerofoils. Thus the result is in conflict with Preston's expression in that this predicts that k should vary inversely as the aspect ratio, and the disagreement led to the suggestion made later for an alternative model for the flow.

2 FLOW MODELS

Before the introduction of the proposed flow model, a number of other approaches, including Preston's, are considered and deemed to be unsatisfactory.

Consider an aerofoil mounted between walls at a very high Reynolds number so that the flow can be considered to be effectively inviscid. The disturbance introduced into the flow by the aerofoil can be represented by a distribution of vortex lines lying along the generators of the aerofoil surface. The sum of the circulations about the vortex lines on the upper and lower surfaces will be equal to the circulation about the aerofoil. The vortex lines cannot terminate at the ends of the aerofoil and so must spread approximately radially on the end walls, in fact, in such a manner that the two-dimensional flow field about the aerofoil is obtained over the walls. If now the Reynolds number is reduced so that boundary layers of finite thickness exist over the aerofoil surfaces and the walls, it is to be expected that the pattern of vortex lines will remain substantially the same. In the Preston model it is assumed that the vortex lines, or at any rate those associated with the circulation around the aerofoil, turn at the wall and trail in the downstream direction. It seems implausible that this is what happens in reality, but there is no simple way to determine the actual behaviour of the vortex lines.

The main feature which is observed when an obstacle such as an aerofoil protrudes from a wall is the so-called scarf vortex wrapped round the obstacle and resulting from separation of the wall boundary layer upstream of the leading edge of the obstacle. This vortex is of relatively small scale and is unlikely to have any significant effect on the flow external to the boundary layer.

Investigations of endwall boundary-layer effects have been made extensively in relation to the performance of cascades (see Ref 4 for elegant

examples of flow visualization). Since a single aerofoil between end walls may be regarded as an element of a cascade with large spacing ratio and small turning angle, the established effects for cascades give some guidance to the considerations for an aerofoil. The main effect in a cascade is the secondary motion which results from the turning, as sketched in Fig 2. The pressure gradient towards the centre of curvature of the streamlines of the primary flow overcomes the inertia of the slower-moving fluid in the boundary layer, setting up a secondary flow of fluid moving (in a plane normal to the primary streamlines) towards the centre close to the end walls and returning further away from them. The motion is thus in the opposite sense to the trailing vorticity from a lifting wing of finite aspect ratio. In the context of cascades attention is concentrated on the determination of losses, and the effect of the vorticity is only considered downstream of the blade elements, effectively as a two-dimensional flow in the cross-flow plane. However, by analogy with the flow over a finite wing, the trailing vorticity associated with the secondary motion may be expected to produce an upwash on the centre-line of a blade element.

Consider now a single aerofoil spanning a wind tunnel: the net deflection of the mainstream flow is zero, so that the simple dependence obtained for a cascade of the streamwise vorticity on the turning angle cannot be invoked. Nevertheless some form of secondary motion will occur, and that in the vicinity of the aerofoil will have a dominating effect, in respect of induced angle of incidence, compared with the motion a long way upstream or downstream of the aerofoil. In the immediate vicinity of the aerofoil pressure gradients transverse to the mainstream flow will occur. Above the upper, or suction, surface the pressure will increase with distance away from the aerofoil resulting in a secondary motion towards the surface of the aerofoil of the slowly-moving fluid in the boundary layer; below the lower surface the pressure will decrease with distance away from the aerofoil and hence the secondary motion in the boundary layer will be directed away from the surface of the aerofoil. Thus, as sketched in Fig 3, trailing vorticity will be created which is of opposite sign to that for a lifting wing of finite span in free air. This trailing vorticity will produce an upwash on the centre-line of the aerofoil. However, because the local turning angle is small the effect may be expected to be small.

From the foregoing it is argued that it is unlikely that the observed behaviour can be explained in terms of effects induced by vorticity fields at the ends of the aerofoil. An alternative explanation may be sought in terms of a simple displacement effect. The simple model proposed is that the velocity

increment over the upper surface will lead to a reduction in boundary-layer thickness on the sidewalls above the aerofoil and the opposite will occur below the aerofoil. Thus by continuity of mass flow in the 'channels' above and below the aerofoil there will be a tendency for the displacement effect to oppose the velocity perturbations associated with the lift on the aerofoil and so to reduce this lift. This assumption of one-dimensional flow means, of course, that the effects are constant across the span in contrast to the variation predicted by Preston. In the next section an approximate calculation is described for comparison with the ONERA measurements.

Since the completion of the work described in this Memorandum the paper by Barnwell⁸ has become available which deals with the same problem in a more general way. He treats the changes in effective width of the tunnel, caused by the changes in boundary-layer thickness on the sidewalls due to the presence of an aerofoil, as modifying the continuity equation so that a scaling is introduced on the u -component of velocity. The change in normal force is then related to this scaling factor in a manner analogous to the use of the Prandtl-Glauert factor to account for the effects of compressibility. For a Mach number of 0.3 the predictions are in excellent agreement with the results of the ONERA tests.

The present work may be regarded as complementary to that of Barnwell in explaining in rather simpler terms and with different approximations the mechanism of the effects of sidewall boundary layers, which it is difficult to visualize in his mathematical approach.

3 CALCULATION OF BOUNDARY-LAYER DISPLACEMENT EFFECT

3.1 Flow field of aerofoil

A full calculation of the displacement effect would be rather complicated, taking account of the distribution of displacement thickness over the aerofoil and over the walls, roof and floor of the tunnel. The approximation adopted is to treat the flow in each of the two passages formed above and below the aerofoil as being that in a channel of varying width, with the conditions at some typical distance from the aerofoil used to define the width of the channel. The flow is taken to be incompressible and, since the thickness of the aerofoil would produce symmetrical perturbations above and below the aerofoil and the effects of camber are expected to be of higher order, the aerofoil is represented simply as an inclined flat plate.

The velocity field is obtained by conformal transformation from the flow about a circular cylinder with circulation. The complex velocity potential w for the flow about a circular cylinder of radius a , in a plane ζ , with velocity at infinity U inclined at an angle α to the real axis and with circulation κ is

$$w = U \left\{ \zeta e^{-i\alpha} + \frac{a^2}{\zeta} e^{i\alpha} \right\} + \frac{i\kappa}{2\pi} \log \zeta .$$

The transformation $Z = \zeta + a^2/\zeta$ maps the region outside the circle $|\zeta| = a$ in the ζ -plane on to the Z -plane cut along a segment of the real axis of length $4a$. Applying the Kutta condition at the trailing edge of the flat plate represented by the cut defines the circulation as $\kappa = 4\pi U a \sin \alpha$ (see for example Thwaites⁵ (p 114)). Thus the complex conjugate of the velocity in the ζ -plane is given by

$$\frac{dw}{d\zeta} = U \left(e^{-i\alpha} + \frac{a}{\zeta} e^{i\alpha} \right) \left(1 - \frac{a}{\zeta} \right)$$

and in the Z -plane by

$$\frac{dw}{dz} = U \frac{e^{-i\alpha} + \frac{a}{\zeta} e^{i\alpha}}{1 + \frac{a}{\zeta}} .$$

The velocity components u and v are given in the physical plane, with $\zeta = re^{i\theta}$, by

$$\begin{aligned} \frac{u - iv}{U} &= \frac{re^{-i\alpha} + ae^{i(\alpha-\theta)}}{r + ae^{-i\theta}} \\ &= \frac{r^2 e^{-i\alpha} + 2ar \cos(\theta - \alpha) + a^2 e^{i\alpha}}{r^2 + 2ar \cos \theta + a^2} \end{aligned}$$

or

$$\begin{aligned} \frac{u}{U} &= \cos \alpha + \frac{2ar \sin \theta \sin \alpha}{r^2 + 2ar \cos \theta + a^2} \\ \frac{v}{U} &= \frac{(r^2 - a^2) \sin \alpha}{r^2 + 2ar \cos \theta + a^2} . \end{aligned}$$

For small values of α

$$\frac{u}{U} = 1 + \frac{2\alpha \frac{a}{r} \sin \theta}{1 + \frac{2a}{r} \cos \theta + \frac{a^2}{r^2}} \quad (1)$$

$$\frac{v}{U} = \alpha \frac{1 - \frac{a^2}{r^2}}{1 + \frac{2a}{r} \cos \theta + \frac{a^2}{r^2}} \quad (2)$$

where the Cartesian coordinates of a point in the Z -plane are given by

$$x = \left(r + \frac{a^2}{r}\right) \cos \theta \quad \text{and} \quad y = \left(r - \frac{a^2}{r}\right) \sin \theta \quad (3)$$

3.2 Specific calculations

The tests in Ref 2 were made in a tunnel of width 80 mm and height 380 mm, on aerofoils of chord length between 120 mm and 60 mm. The aerofoils were of section either NACA 0012 or ONERA LC 100D; for the tests on the former spanning the width of the tunnel the roof and floor of the tunnel were solid and for the tests on the latter perforated. The representative velocity distribution is taken to be that at a distance of 120 mm above and below the aerofoil, that is, respectively one chord and two chords for aerofoils of chord 120 mm and 60 mm. (This distance perhaps would be more representative if a smaller value were to be taken for the smaller aerofoil.)

In the tests the boundary layer thickness on the sidewalls was varied by applying suction over porous regions upstream of the aerofoil. The regions terminated at a distance of about 210 mm upstream of the leading edge of the larger aerofoil.

In the calculations the velocity perturbations were taken to be zero at the end of the porous region and calculations were made of the boundary layer growth starting from this point for a range of values of the initial boundary layer thickness. The calculations were made for two-dimensional flow taking account only of the velocity perturbations parallel to the chord of the aerofoil.

The velocity perturbations calculated from equations (1) and (3) for an angle of incidence $\alpha = 0.1$ rad for the two cases are shown in Fig 4, plotted against x/c where $c = 4a$. The broken lines show the arbitrary fairing to zero perturbation at the point at which the boundary-layer calculations were started. The calculations were made by the method of Ref 6 for velocity distributions above and below the aerofoil by taking the velocity perturbations as positive and negative respectively. The Reynolds number taken corresponded to a value of 3.5×10^6 for an aerofoil of chord 120 mm. A range of initial values of boundary-layer thickness was taken, the largest corresponding to an estimate of the value in the experiment for no suction, all with a shape parameter of 1.275. The calculated values of displacement thickness above and below the aerofoil are shown in Fig 5a&b for six values of the initial thickness. Also shown in Fig 5a is the distribution of displacement thickness in the absence of the aerofoil. The results are respectively for values of aerofoil chord of 120 mm and 60 mm in Fig 5a&b.

With the assumption, noted previously, that the flow is treated as being that in a channel of varying width the local mean velocities above and below the aerofoil are respectively

$$U_u = \frac{U}{1 - \frac{\delta_u^*}{b}}, \quad U_l = \frac{U}{1 - \frac{\delta_l^*}{b}},$$

and the difference in velocity is approximately

$$U_l - U_u = \frac{U}{b} (\delta_l^* - \delta_u^*) . \quad (4)$$

The derivation of equation (4) neglects the effects of the perturbations in velocity due directly to the presence of the aerofoil since these will have only a higher-order contribution. Effectively the difference in velocity given by equation (4) may be treated as a distribution of vorticity along the aerofoil chord superposed upon that which would occur in a uniform flow. The total change in circulation is then

$$\begin{aligned} -\Delta\kappa &= U \int_0^c \frac{1}{b} (\delta_l^* - \delta_u^*) dx = U \frac{c^2}{b} \int_0^1 \frac{1}{c} (\delta_l^* - \delta_u^*) d\left(\frac{x}{c}\right) \\ &= U \frac{c^2}{b} I \quad \text{say.} \end{aligned}$$

The circulation due to angle of incidence is

$$\kappa = \pi U c \alpha$$

hence

$$-\frac{\Delta\kappa}{\kappa} = -\frac{c}{b} \frac{I}{\pi\alpha}$$

and this quantity is equal to the fractional change in lift coefficient $\Delta C_L / C_L$.

The quantity $-\Delta\kappa/\kappa$ is plotted in Fig 6 against the displacement thickness of the undisturbed boundary layer at the position of the leading edge of the larger aerofoil, non-dimensionalized by the semi-span. As can be seen $-\Delta\kappa/\kappa$ is not proportional to δ^*/b , as it was found to be in the experiments. This result is plausible since the effect of the pressure gradient on the boundary-layer thickness will depend upon some average of the thickness of the boundary layer over the field of influence of the pressure gradient. As can be seen in Fig 5, the average thickness of the boundary layer over the region of influence is appreciably less than the datum thickness (that at the leading edge of the larger aerofoil) when this is small; as the thickness increases, the datum thickness becomes more representative of the average. Hence points in Fig 6 will be displaced further to the right of a straight line through the origin as the boundary-layer thickness is reduced, and this is the feature observed in the results of the calculations. If the predictions for the very small values of δ^*/b are ignored, roughly linear portions of the curves remain. These have slopes respectively of 1.05 and 0.63 for chords of 120 mm and 60 mm, compared with an experimental value of roughly 1.5. Thus whilst the calculation gives results of the same order as the experiment, the effect is not predicted to be independent of chord length. With the very simple calculations of the flow undertaken it is easy to suggest an explanation for the discrepancy. It has been assumed that the passages above and below the aerofoil can be treated as channels with parallel sidewalls; it is likely that, in fact, the regions closer to the aerofoil will have a dominant influence. For the smaller chord aerofoil the pressure gradients at a given distance in terms of aerofoil chord are larger than those for the longer aerofoil and hence will have a greater effect on the boundary-layer thickness. Thus a more complete calculation would probably give a result with less difference in the effect with change in aerofoil chord. In fact this trend is shown in the present calculations, since the calculated effect is not halved for the smaller chord aerofoil, although the perturbations are taken at a distance of two chords away from it, instead of the one chord taken for the larger chord aerofoil.

4 CONCLUSIONS

(1) The effect of the sidewall boundary layers in a two-dimensional aerofoil test facility has been modelled by considering a displacement correction to the velocities above and below the aerofoil. The flow has been treated as being incompressible; for flow at high Mach number a further effect due to the change in Mach number above and below the aerofoil might need to be taken into account. For aerofoils of chord length 0.32 and 0.16 times tunnel height the model predicts a fractional reduction in lift over the central span of the aerofoils of 1.05 and 0.63 times the ratio of boundary layer thickness to semi-span respectively. This compares with a measured value of roughly 1.5 independent of the aerofoil chord.

(2) This degree of agreement associated with the simplicity of the calculation procedure suggests that the dominant flow mechanism has been recognised. If more accurate predictions are required, the classical procedure is recommended; first calculate the inviscid flow past the aerofoil in the tunnel, then calculate the boundary layer growth over the aerofoil and tunnel surfaces, finally recalculate the inviscid flow past the displacement surface.

(3) If the aspect ratio of the tunnel cross-section becomes nearer unity the present simplified treatment would need revising to take account of the boundary layers on the tunnel floor and roof and, possibly, on the aerofoil. However for the example calculated by Ashill and Weeks⁷ for an aerofoil tested in a square tunnel with height four times the aerofoil chord the effects of the boundary layers on roof and floor are shown to be negligible.

LIST OF SYMBOLS

a	radius of circular cylinder
A	aspect ratio
b	semi-span of aerofoil
c	aerofoil chord (= 4a)
C_N	normal-force coefficient
C_L	lift coefficient
r, θ	polar coordinates in ζ -plane
U	freestream velocity
u, v	components of local velocity
w	complex velocity potential
x, y	Cartesian coordinates
Z	= $x + iy$
α	angle of incidence
δ^*	boundary-layer displacement thickness
κ	circulation
ζ	complex variable in transformed plane

Subscripts

u	upper
l	lower

REFERENCES

- | <u>No.</u> | <u>Author</u> | <u>Title, etc</u> |
|------------|--|--|
| 1 | J.H. Preston | The interference on a wing spanning a closed tunnel, arising from the boundary layers on the sidewalls, with special reference to the design of two-dimensional tunnels.
R & M 1924, March 1944 |
| 2 | R.A. Mendelsohn
Josephine F. Polhamus | Effect of the tunnel-wall boundary layer on test results of a wing protruding from a tunnel wall.
NACA TN 1244, April 1947 |
| 3 | R. Bernard-Guelli | Influence des couches limites latérales de soufflerie dans les essais transsoniques en courant plan.
12 ^{ème} Colloque d'Aérodynamique Appliquée
ENSMA/CERT Poitiers, Nov 1975 |
| 4 | Ph Marchal
C.H. Sieverding | Secondary flows within turbo-machinery bladings.
Paper 11, AGARD CP-214 (1977) |
| 5 | B. Thwaites
(Editor) | Incompressible aerodynamics.
OUP 1960 |
| 6 | J.E. Green
D.J. Weeks
J.W.F. Brooman | Prediction of turbulent boundary layers and wakes in compressible flow by a lag-entrainment method.
R & M 3791 (1973) |
| 7 | P.R. Ashill
D.J. Weeks | An experimental investigation of the drag of thick supercritical aerofoils - a progress report
RAE TM Aero 1765 (1978) |
| 8 | R.W. Barnwell | A simularity rule for compressibility and sidewall-boundary-layer effects in two-dimensional wind tunnels.
AIAA 79-0108 (1979) |

reports quoted are not necessarily available to members of the public or to commercial organisations.

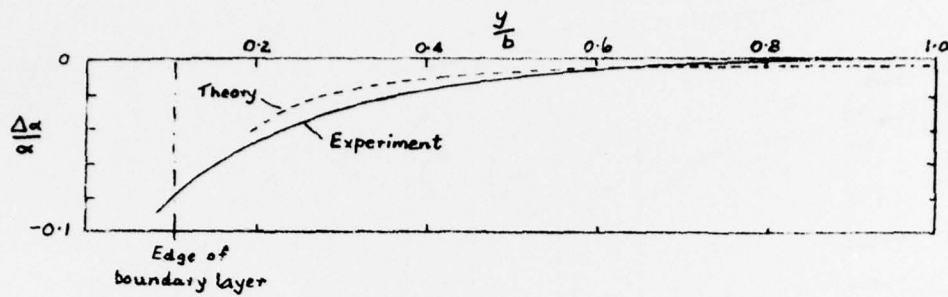

(a) Preston (ref 1)

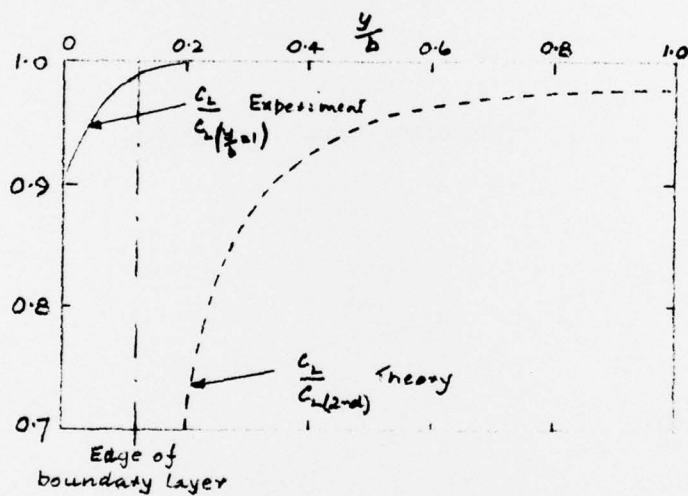

(b) Mendelsohn and Polhamus (ref 2)

Fig 1 Comparisons of Preston's theory with experiment

Figs 2&3

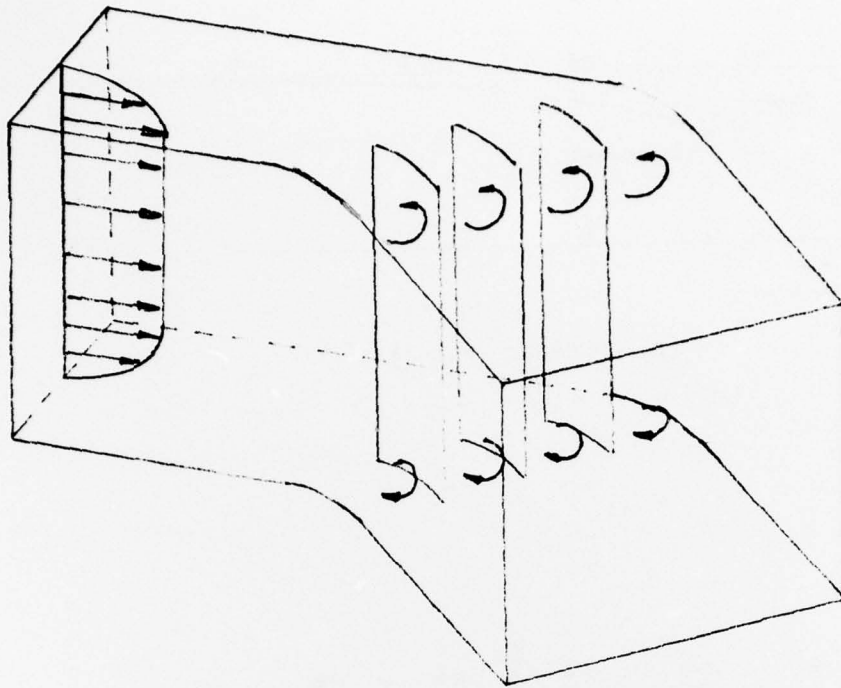

Fig 2 Secondary flow in a cascade

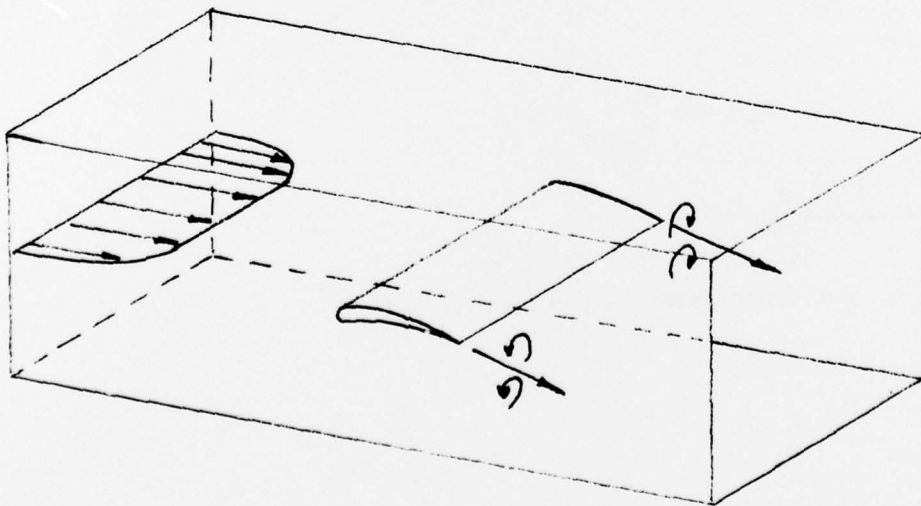
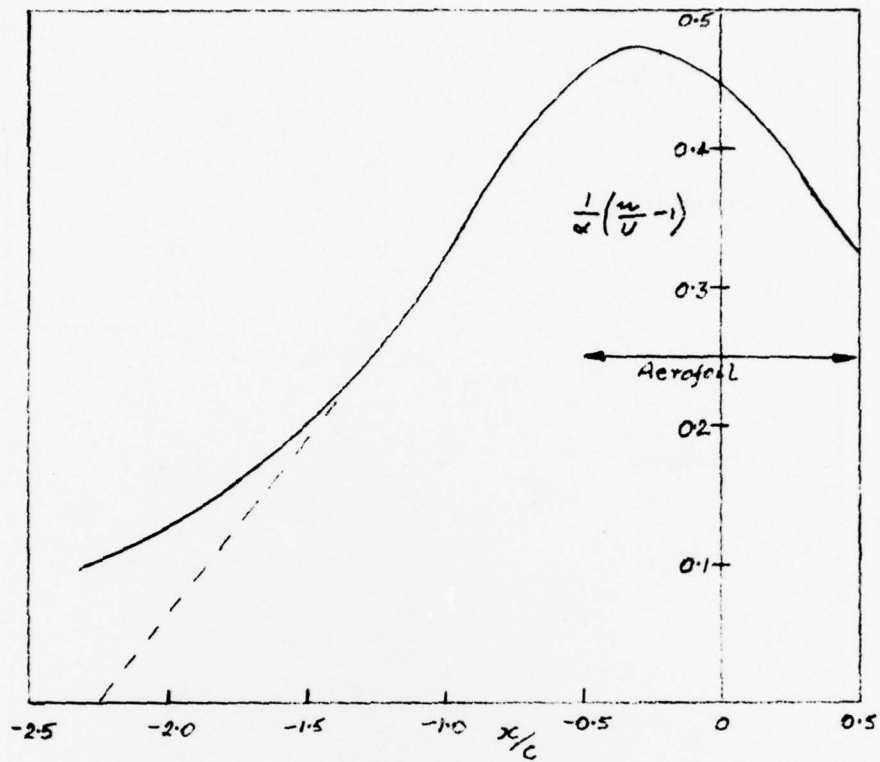
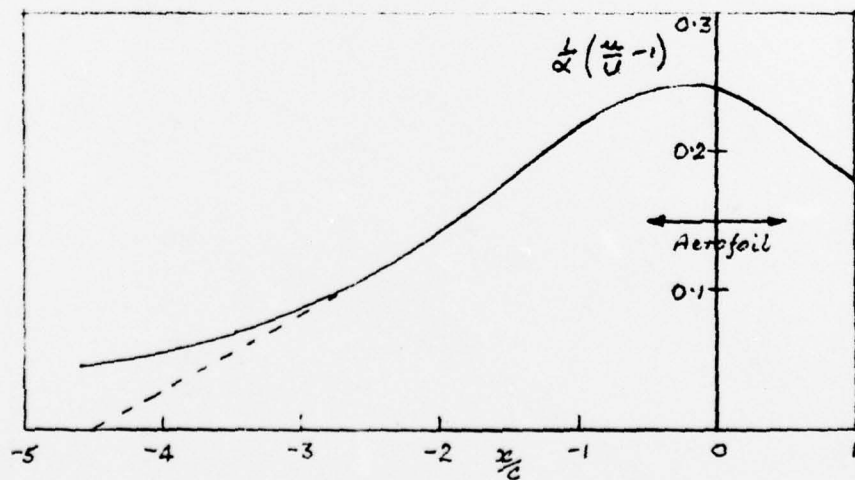

Fig 3 Secondary motion due to flow turning for a single aerofoil



(a) $y/c = 1$



(b) $y/c = 2$

Fig 4 Perturbation velocity parallel to inclined flat plate

Fig 5a

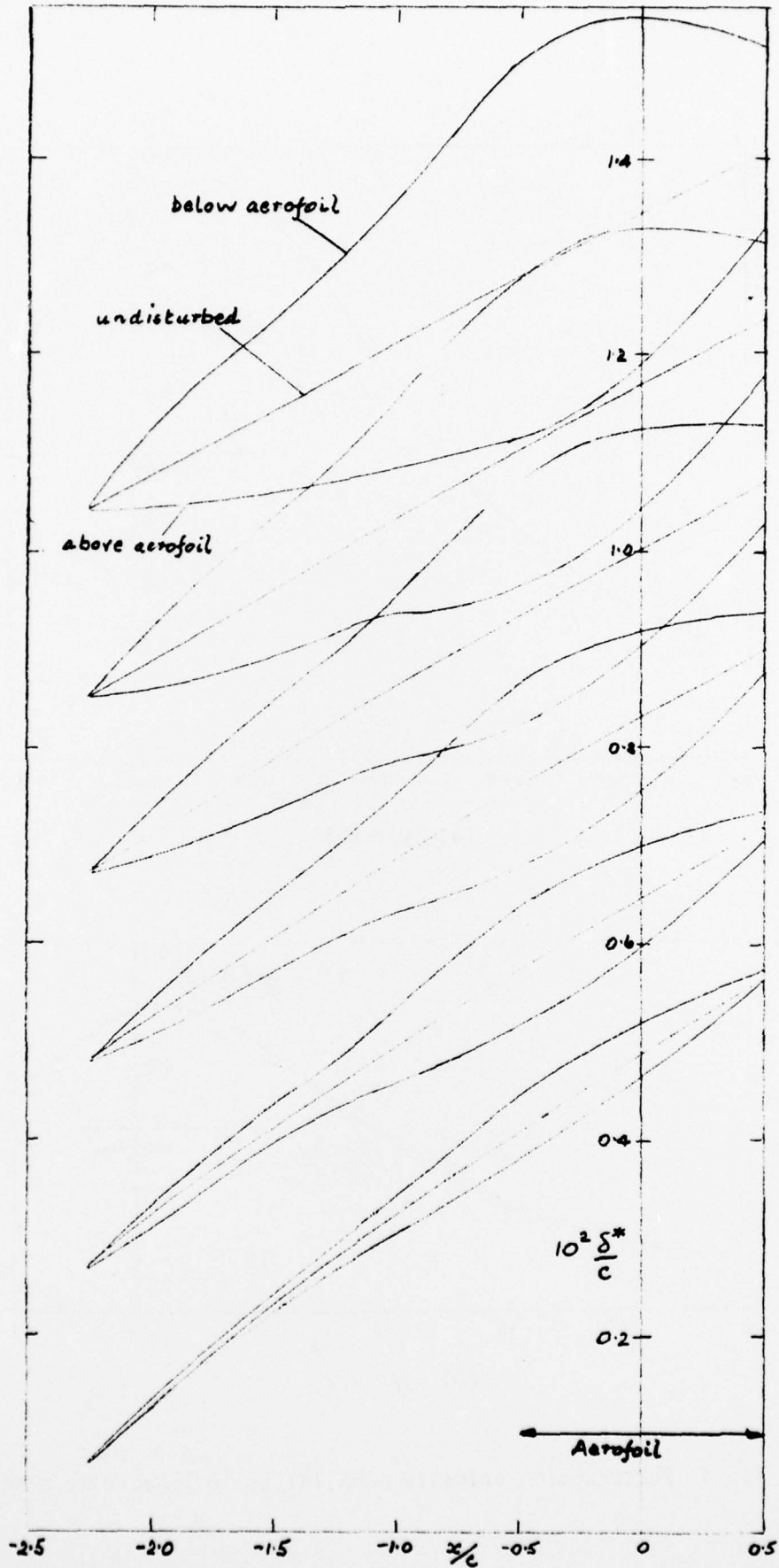
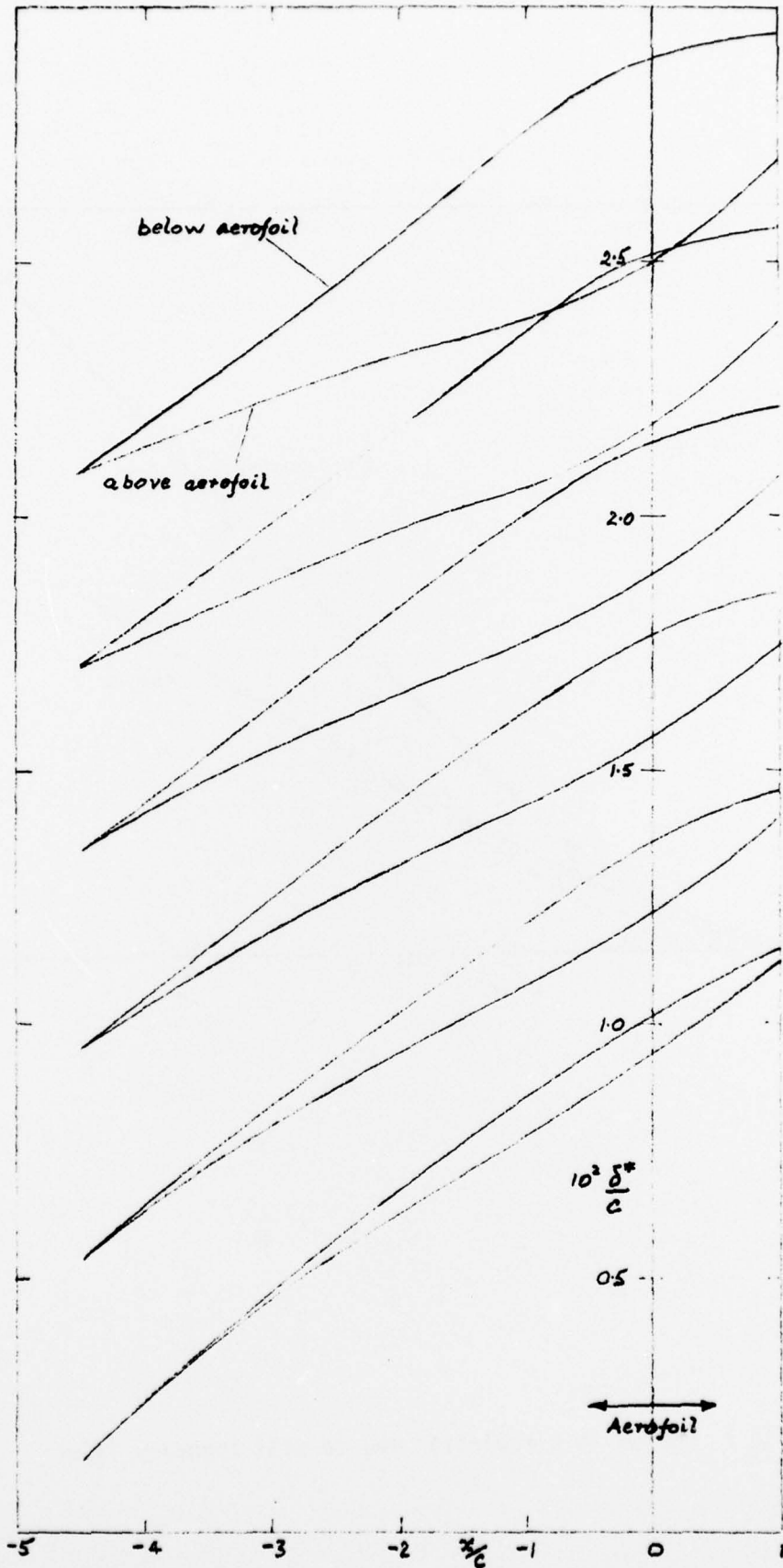

Fig 5a Boundary layer displacement thickness $y/c = \pm 1$, $c = 120$ mm

Fig 5b



TM Ae 1816

Fig 5b Boundary layer displacement thickness $y/c = \pm 2$, $c = 60$ mm

Fig 6

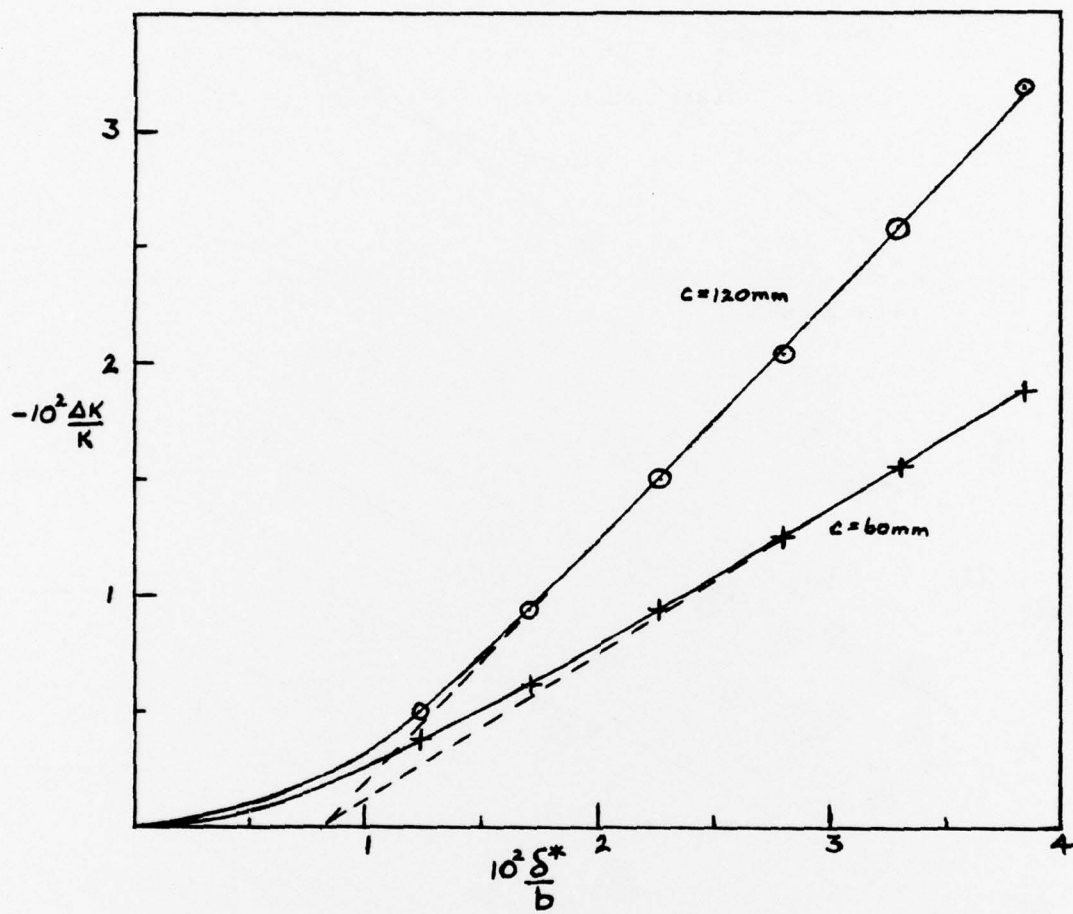

Fig 6 Change in circulation due to wall boundary layer

REPORT DOCUMENTATION PAGE

Overall security classification of this page

UNLIMITED

As far as possible this page should contain only unclassified information. If it is necessary to enter classified information, the box above must be marked to indicate the classification, e.g. Restricted, Confidential or Secret.

1. DRIC Reference (to be added by DRIC)	2. Originator's Reference RAE TM Aero 1816	3. Agency Reference N/A	4. Report Security Classification/Marking UNLIMITED
5. DRIC Code for Originator 7673000W	6. Originator (Corporate Author) Name and Location Royal Aircraft Establishment, Farnborough, Hants, UK		
5a. Sponsoring Agency's Code N/A	6a. Sponsoring Agency (Contract Authority) Name and Location N/A		
7. Title A comment on the origin of endwall interference in wind-tunnel tests of aerofoils.			
7a. (For Translations) Title in Foreign Language			
7b. (For Conference Papers) Title, Place and Date of Conference			
8. Author 1. Surname, Initials Winter, K.G.	9a. Author 2 Smith, J.H.B.	9b. Authors 3, 4	10. Date Pages Refs. August 18 8 1979
11. Contract Number N/A	12. Period N/A	13. Project	14. Other Reference Nos.
15. Distribution statement (a) Controlled by – (b) Special limitations (if any) –			
16. Descriptors (Keywords) (Descriptors marked * are selected from TEST) Aerofoils*. Wind-tunnel interference.			
17. Abstract Tests have been made recently at ONERA on the interference effects arising from the presence of the boundary layers on the walls at the ends of an aerofoil spanning the working section of a wind tunnel. The tests revealed a behaviour different from that predicted by the theory of Preston. A qualitative assessment of the problem is made and it is suggested that the interference is better explained in terms of changes in the displacement thickness of the boundary layers on the tunnel walls than in terms of induced effects from trailing vorticity.			

F 5910/1