

AD-A078 339

DEFENCE RESEARCH ESTABLISHMENT OTTAWA (ONTARIO)  
DESIGN AND DEVELOPMENT OF THE SERVO SYSTEM FOR THE BACK-UP OPTI--ETC(U)  
MAY 79 J P LEE

F/G 14/3

UNCLASSIFIED

DREO-TN-79-9

NL

/ OF 1  
AD  
A078339

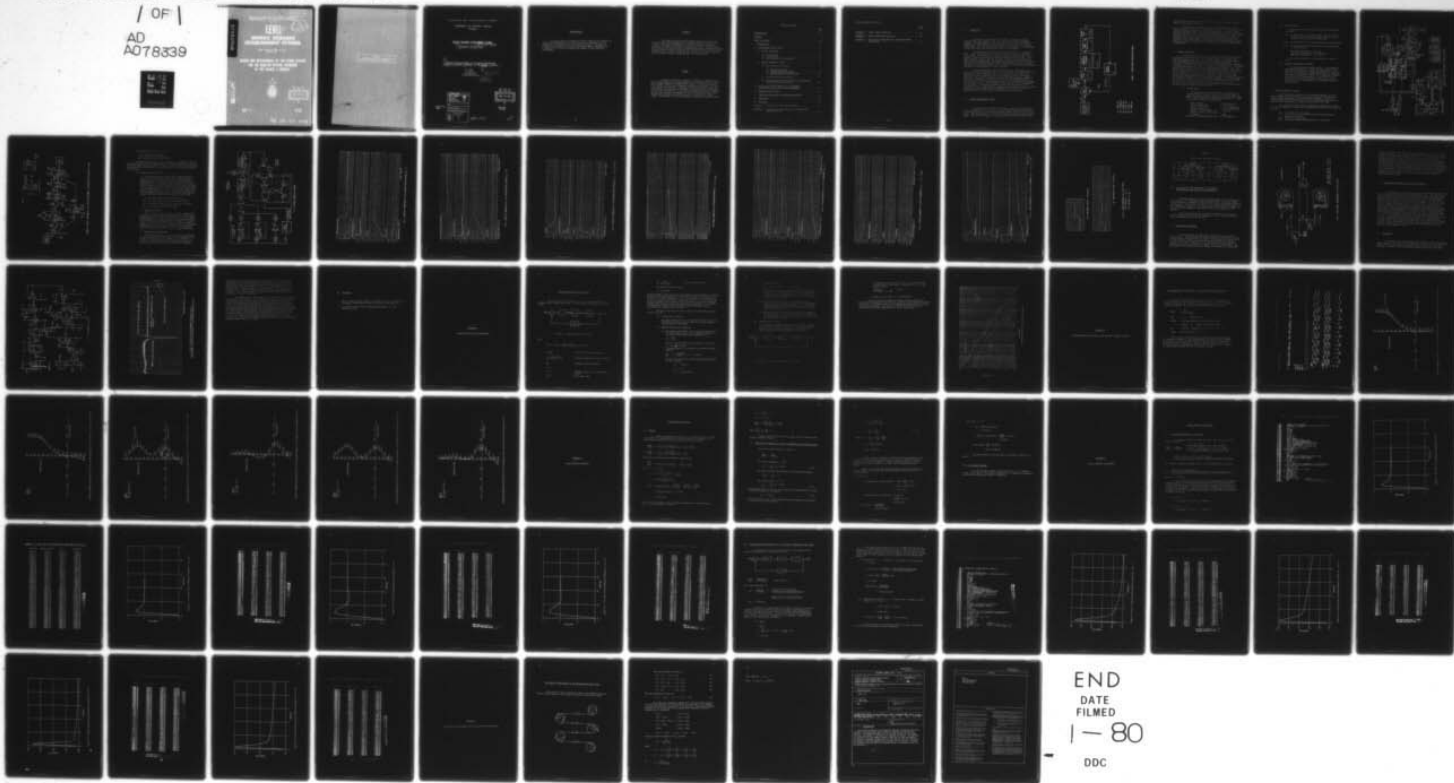

END  
DATE  
FILMED  
1-80  
DDC

RESEARCH AND DEVELOPMENT BRANCH  
DEPARTMENT OF NATIONAL DEFENCE  
CANADA

3

ADA 078339

LEVEL II

**DEFENCE RESEARCH  
ESTABLISHMENT OTTAWA**

DREO TECHNICAL NOTE NO. 79-9  
DREO TN 79-9

**DESIGN AND DEVELOPMENT OF THE SERVO SYSTEM  
FOR THE BACK-UP OPTICAL RECORDER  
OF THE SEASAT A PROJECT**

by  
J.P. Lee



D D C  
RECEIVED  
DEC 14 1979  
R  
REGISTRY  
D

D D C FILE COPY

PROJECT NO.  
33000

MAY 1979  
OTTAWA

**CAUTION**

This information is furnished with the express understanding  
that proprietary and patent rights will be protected.

RESEARCH AND DEVELOPMENT BRANCH

DEPARTMENT OF NATIONAL DEFENCE  
CANADA

DEFENCE RESEARCH ESTABLISHMENT OTTAWA

9 TECHNICAL NOTE (NO. 79-9) 14 DRES-711-

6 DESIGN AND DEVELOPMENT OF THE SERVO SYSTEM FOR THE BACK-UP OPTICAL RECORDER OF THE SEASAT A PROJECT.

10 by J.P./Lee  
Radar/ESM Section  
Defence Electronics Division

11 May 79

12 82

PROJECT NO.  
33D00

Accession For	
NTIS GRA&I	<input checked="" type="checkbox"/>
DDC TAB	<input type="checkbox"/>
Unannounced	<input type="checkbox"/>
Justification	
By _____	
Distribution/ _____	
Availability Codes	
Dist.	Avail and/or special
A	

DDC  
RECEIVED  
DEC 14 1979  
D

MAY 1979  
OTTAWA

404 576

AB

ACKNOWLEDGMENT

The author wishes to express his sincere thanks to W.G. Thistle for setting up the framework of the servo design and B. Kozminchuk for his helpful and constructive role in carrying out the work. Assistance by R. Millar and G. Bower for setting up the analog computer simulation and M. McMillan for the servo electronics development is also gratefully acknowledged.

### ABSTRACT

This report is written on the design, analysis, simulation and final testing of the phaselocked servo system for the back-up optical film recorder. The design procedure used is the Bode method and a position resolution equivalent to  $2\pi/(5000 \times 16)$  radians is desired. The analysis is carried out by both analog computer simulation and digital computer calculations. Separate control circuits are used for the reel servos and the tension motors are supplied with constant current sources. Finally the complete system was built and tested, giving a performance which met specification.

### RÉSUMÉ

Ce rapport comprend la conception, l'analyse, la simulation ainsi que les tests finaux sur un système asservi par accrochage de phase utilisé comme système secondaire d'enregistrement optique. La procédure utilisée est la méthode de Bode et une résolution de position équivalente à  $2\pi/(5000 \times 16)$  radians était désirée. L'analyse a été exécutée de deux façons, une simulation sur une calculatrice analogique ainsi qu'une solution d'équations sur calculatrice numérique. Des circuits de contrôle séparés sont utilisés pour les servo moteurs d'enroulement, et les servo moteurs de tension sont alimentés par des sources de courant constant. Finalement le système complet fut assemblé et vérifié, donnant une performance en-deca des normes.

TABLE OF CONTENTS

	<u>Page</u>
<u>ACKNOWLEDGMENT</u> . . . . .	iii
<u>ABSTRACT</u> . . . . .	v
<u>TABLE OF CONTENTS</u> . . . . .	vii
I. <u>INTRODUCTION</u> . . . . .	1
II. <u>CAPSTAN SERVO CONTROL SYSTEM</u> . . . . .	1
A. GENERAL DESCRIPTION . . . . .	3
(1) CAPSTAN MOTOR . . . . .	3
(2) PHASE DETECTOR . . . . .	4
(3) LAG-LEAD NETWORK AND INTEGRATOR . . . . .	4
B. SYSTEM PERFORMANCE ANALYSIS . . . . .	4
(1) ANALOG COMPUTER SIMULATION . . . . .	7
(a) <u>Start-Up Transients</u> . . . . .	7
(b) <u>External Step Disturbances</u> . . . . .	7
(c) <u>System Response To A Step Input</u> . . . . .	15
(2) DIGITAL COMPUTER CALCULATIONS . . . . .	15
(3) COMPARISON BETWEEN ANALOG COMPUTER SIMULATION AND DIGITAL COMPUTER CALCULATIONS . . . . .	15
III. <u>THE EFFECT OF OTHER COMPONENTS IN THE COMPLETE SERVO SYSTEM ON THE CAPSTAN SERVO PERFORMANCE</u> . . . . .	19
IV. <u>TENSION AND REEL SERVOS</u> . . . . .	19
V. <u>TESTING AND EVALUATION OF COMPLETE SERVO SYSTEM</u> . . . . .	21
VI. <u>CONCLUSIONS</u> . . . . .	21
VII. <u>REFERENCES</u> . . . . .	25
<u>APPENDIX A : SYSTEM DESIGN USING THE BODE METHOD</u> . . . . .	27
<u>APPENDIX B : THE MAGNITUDE AND PHASE PLOTS OF THE OPEN LOOP TRANSFER FUNCTION</u> . . . . .	33

TABLE OF CONTENTS (Continued)

	<u>Page</u>
<u>APPENDIX C</u> : ANALOG COMPUTER MODELLING . . . . .	43
<u>APPENDIX D</u> : DIGITAL COMPUTER CALCULATIONS . . . . .	49
<u>APPENDIX E</u> : THE EFFECT OF OTHER MOTORS ON THE CAPSTAN MOTOR SERVO SYSTEM . . . . .	71

## I. INTRODUCTION

The purpose of this report is to present the design, analysis, simulation and final testing of the servo system for the back-up optical recorder. The main emphasis is on the design of a precision, phaselocked capstan servo system which can tolerate high external torque and electrical disturbances. Once the capstan servo system is well designed, the requirement on the rest of the servo system becomes much less stringent.

The framework of the design was originally set by W.G. Thistle of DREO. It is a proportional plus integral control, phaselocked positional servo system. The capstan motor used is the modified PMI type U12M4 with an internal flywheel and an optical tachometer mounted on the frontface. The added flywheel is used to damp out any high frequency torque disturbances applied to the capstan motor. The capstan motor shaft is one inch in diameter and runs at an angular velocity of half a revolution per second. There are 5000 lines on the axially mounted optical encoder disc and a position resolution equivalent to one-sixteenth of a slot is desired.

The design procedure used is the Bode method. The analysis is carried out by two approaches; one is by analog computer simulation using the breadboarded digital phase detector, and the other one is to solve the appropriate transfer function directly on a digital computer. The latter approach is used mainly to provide a check on the analog computer simulation. The system performance is evaluated for a step torque disturbance on the capstan motor with different integrator gains, motor mechanical time constants, gain and phase margins. The step-input response and the start-up transients are also given. A theoretical analysis on how other motors affect the performance of the capstan motor in a symmetrical arrangement is also presented. Finally the complete servo system was assembled and tested using four additional PMI type U12M4 motors for the tension and reel servos.

## II. CAPSTAN SERVO CONTROL SYSTEM

The general block diagram of the servo system is shown in Figure 1. It is a 'proportional plus integral control phaselock positional servo system'. The maximum phase error signal from the phase detector can not exceed  $\pm 2.5$  volts. This corresponds to  $\pm 8$  slots on the optical tachometer of the capstan motor. The phase error signal is used to control both the position of the

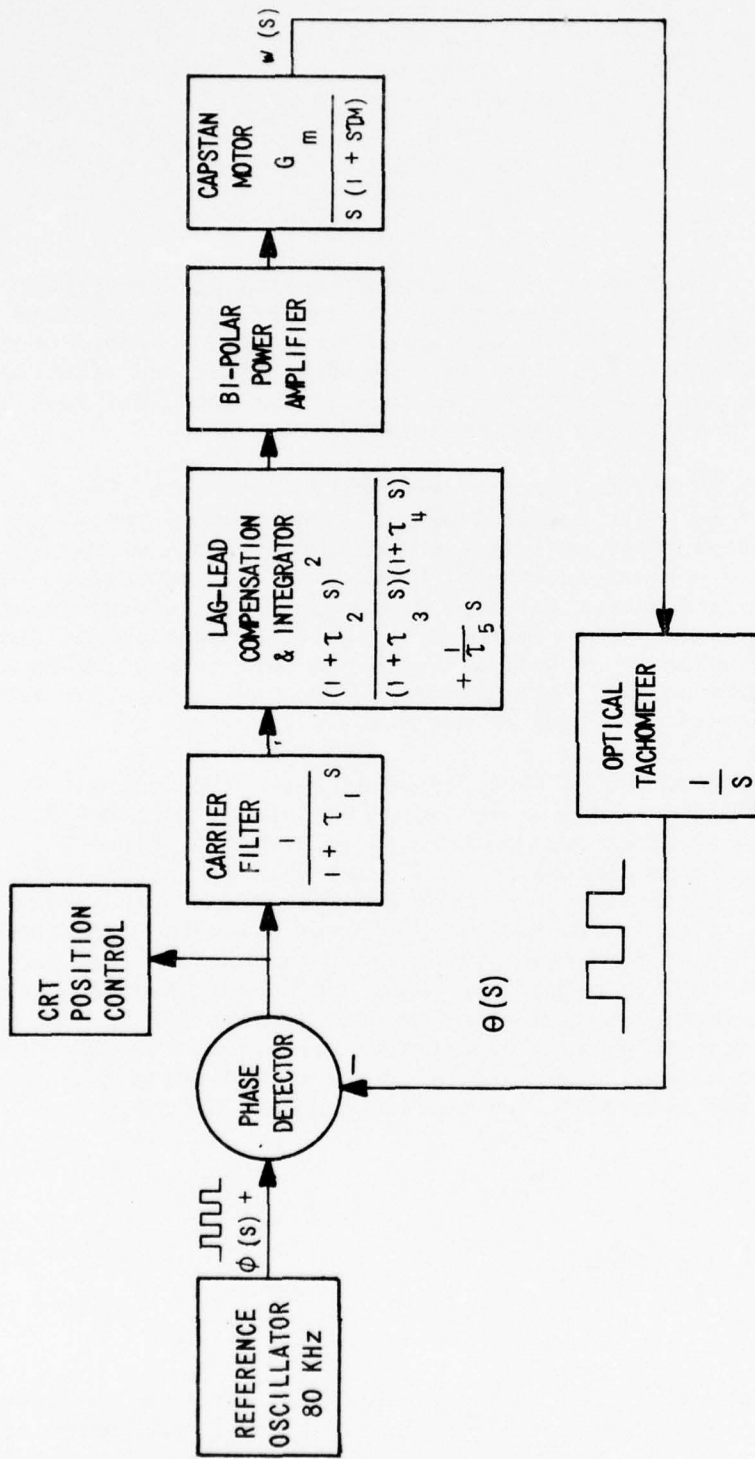

- $\tau_1 = 0.001 \text{ sec}$
- $\tau_2 = 0.1429 \text{ sec}$
- $\tau_3 = 0.509 \text{ sec}$
- $\tau_4 = 0.01 \text{ sec}$
- $G_m = 9.106$
- $\tau_m = 0.509 \text{ sec}$

FIGURE 1. CAPSTAN SERVO SYSTEM BLOCK DIAGRAM

motor and the vertical deflection position of the CRT; the latter provides almost instantaneous correction.

Phaselock motor systems, like all other positional servos, are inherently unstable and must be compensated to operate in a stable mode. The velocity control of DC motors by use of phaselock servo techniques is well documented (GEIGER, 1973). This system is designed to give zero steady state velocity error, very little 'sampled data lag' introduced, and a good noise rejection capacity. It can handle an external step torque disturbance equivalent to at least 4 Oz-In. The details of the design procedure and criteria for the 'proportional plus integral control system' using the Bode method are given in Appendix A and an excellent text on this method is given as Reference 2.

#### A. GENERAL DESCRIPTION

The reference oscillator is a precision, stable VCO with an output rectangular pulse frequency of 80 KHz and an accuracy of  $\pm 0.005\%$  over a temperature range of  $10^{\circ}$ - $30^{\circ}$ C. It is divided down by 32 and phase compared with the feedback pulse train generated by the optical tachometer. The tachometer generates 2500 pulses per second with the capstan motor running at steady state of half a revolution per second. The phase detector is essentially an up-down counter and the difference accumulated is the phase error. The digital error is then converted into analog voltage and used to control both the vertical position of the CRT and the position of the motor. The carrier filter attenuates the high frequency components of the error signal and prevents them from reaching the motor. The error signal is then passed through the lag-lead compensation and integrator network for stability purposes. The integrator responds to the low frequency components of the error signal and supplies the necessary power to drive the capstan motor at the desired speed and thus eliminating the need for another power source. The outputs from the lag-lead network and the integrator are summed and applied to the capstan motor through the power amplifier.

##### (1) CAPSTAN MOTOR

The motor used is the modified PMI type U12M4 with an optical tachometer attached to it. An internal flywheel is added and the motor shaft is extended to a length of 6 inches with a combined additional inertia of 0.807 Oz-In  $\text{sec}^2$ . Some of the motor constants are given below.

Total inertia	=	0.831 Oz-In $\text{sec}^2$ .
Torque constant ( $K_T$ )	=	15.6 Oz-In/A.
EMF constant ( $K_E$ )	=	11.5 volts/1000 RPM
Damping constant ( $K_D$ )	=	3.1 Oz-In/1000 RPM
Mechanical time constant ( $\tau_m$ )	=	0.509 sec.
Number of slots on the optical tachometer	=	5000.
Regulation @ Constant Voltage ( $R_m$ )	=	5.85 RPM/Oz-In

## (2) PHASE DETECTOR

The phase detector performs essentially three functions as follows:

- (i) It ensures that the up-count signal from the reference oscillator and the down-count signal from the optical tachometer do not occur at the same time.
- (ii) It performs the phase comparison using an up-down counter.
- (iii) It converts the digital phase error into analog signal by a D/A converter.

1000 0000 corresponds to zero volt  
 1111 1111 corresponds to -2.48 volts and  
 0000 0000 corresponds to +2.5 volts

The circuit diagram of the phase detector is given in Fig. 2.

## (3) LAG-LEAD NETWORK AND INTEGRATOR

The circuit diagram is shown in Fig. 3. The purpose of the lag-lead network is to improve the phase margin of the system to assure stability, thus permitting the use of high gain, which is essential to minimize the effect of torque and electrical disturbances on speed. The proportional component provides direction and stability. The offset due to the variations in the system parameters, such as the average friction torque, is eliminated by the integrating action of the integrator.

## B. SYSTEM PERFORMANCE ANALYSIS

Once the design is completed in the frequency domain, the time domain response can be evaluated by either solving directly the appropriate inverse Laplace transform or by analog computer simulation. The latter method was employed extensively using the actual breadboarded digital phase detector in the study while the former was used merely as a check.

Two slightly different lag-lead compensation networks were chosen and, for each design, the capstan servo system was evaluated for the following criteria:

- (i) The stability of the system.
- (ii) The phase error introduced as different step-disturbance torques are applied.
- (iii) The start-up performance.
- (iv) The system response when subjected to a step input.

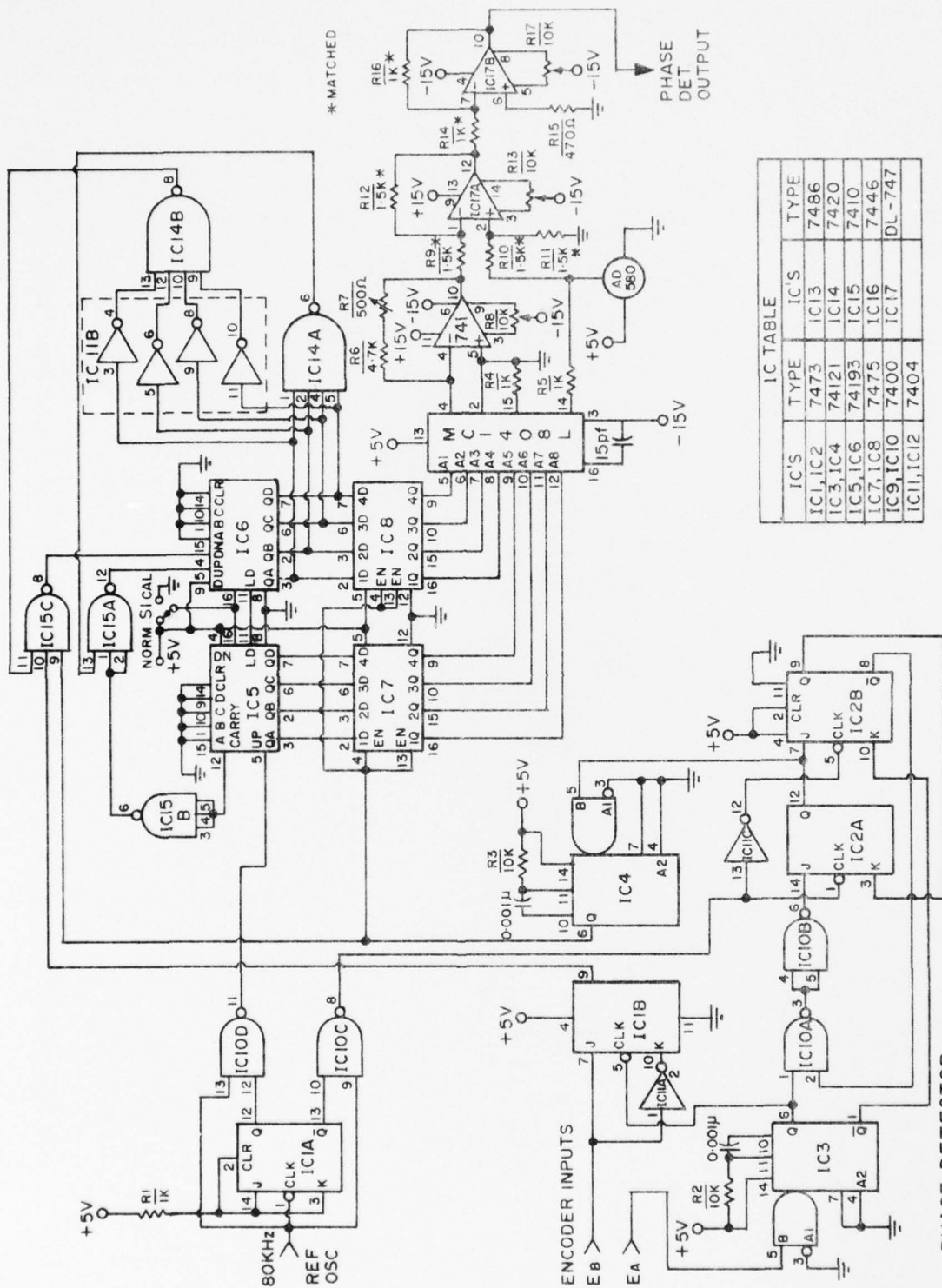

FIGURE 2 CIRCUIT DIAGRAM OF PHASE DETECTOR

PHASE DETECTOR

WHERE  $I = \frac{R5 R8}{(Ra + R4)(R6 + R7)}$   $T3 = \frac{C5 R5}{R6 + R7}$   
 $Ra = Ro + R3$   $T4 = \frac{C7 R7 R6}{R6 + R7}$   
 $Ro = \frac{(R1 R2)}{(R1 + R2)}$   $T5 = C11 R11$   
 $T1 = \frac{C4 R4 Ra}{Ra + R4}$   $R12/R10 = 0.27 \times \frac{R1 + R2}{R2}$   
 $T2 = \frac{C4 R4}{C7 R7}$

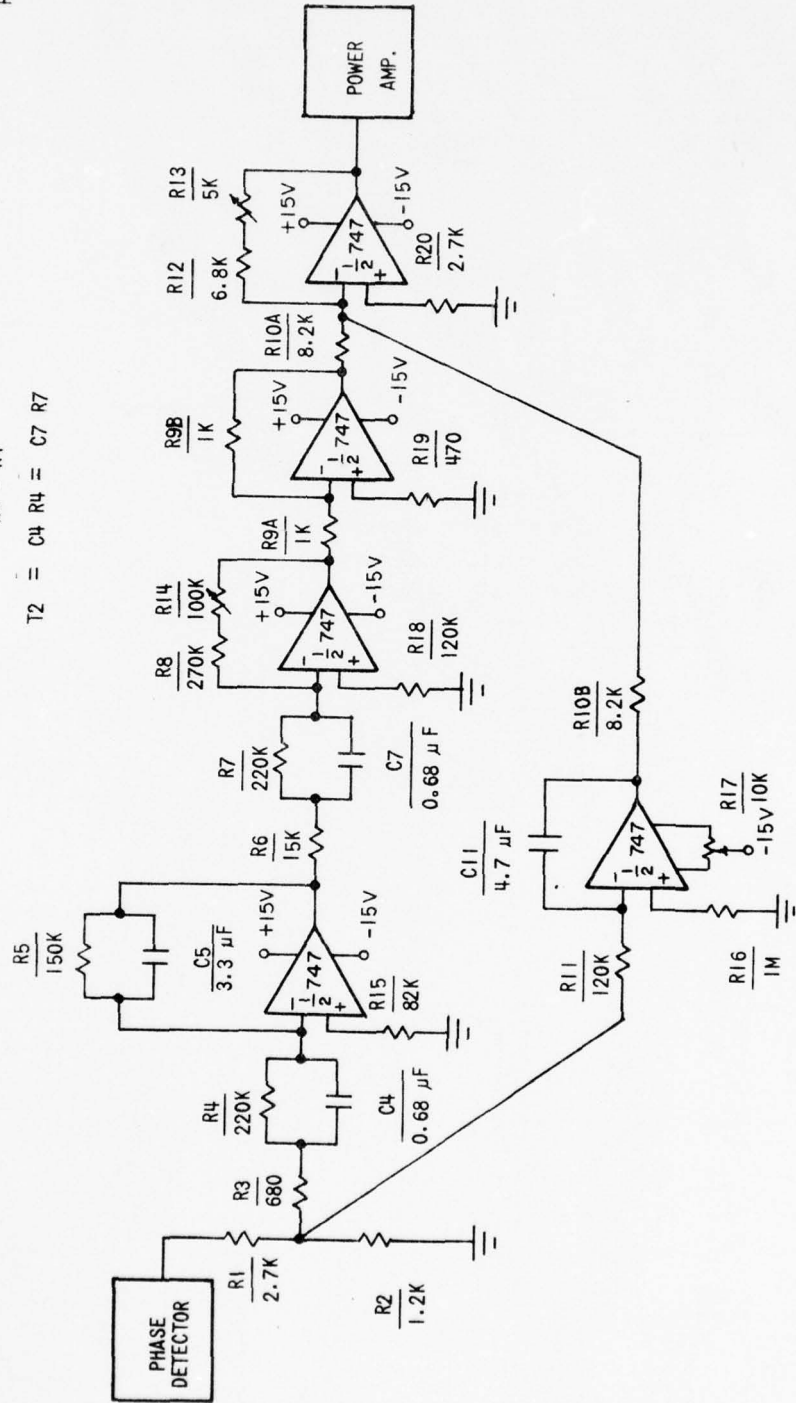

FIGURE 3 CIRCUIT DIAGRAM OF THE LAG-LEAD NETWORK, INTEGRATOR AND CARRIER FILTER

The following parameters were varied:

- (i) Overall open-loop gain.
- (ii) The gain of the integrator.
- (iii) Motor mechanical time constant.

The magnitude and phase plots of the open loop transfer function for each design with different integrator gains are shown in Appendix B. From the plots, the phase and gain margins are illustrated clearly as the overall open-loop gain is varied and thus give a general picture of the relative stability of the system.

#### (1) ANALOG COMPUTER SIMULATION

The simulation of the capstan servo system was carried out on the AD Five hybrid computer at the Communications Research Centre. The actual breadboarded phase detector was incorporated with the analog computer. The details of the modelling of the servo system and the simulation of external torque disturbances on the capstan motor are given in Appendix C. The analog computer diagram for the complete capstan servo system is shown in Figure 4. The two designs are quite similar in system performance and thus only the results of design #1 will be presented in detail here. Some of the important parameters of interest given below were measured and plotted.

- (i) The phase detector error signal ( $V_i/V_{im}$ ).
- (ii) The output signal from the integrator ( $-F/F_m$ ).
- (iii) The combined signal ( $V_o/V_{om}$ ) applied to the motor.
- (iv) The output angular velocity ( $\frac{\omega}{\omega_m}$ ).

##### (a) Start-Up Transients

Shown in Figures 5 and 6 are the start-up transients for design #1 with two different integrator gains. Using a lower integrator gain, the system takes longer to reach the steady-state angular velocity and the phase error decays more slowly. In this simulation, the average frictional torque is taken to be zero. If it is taken into account, the time to reach the steady-state velocity will be increased further. Two different mechanical time constants were also simulated and shown in Figs. 7 and 8 with  $\tau_m$  equals  $1/3 \tau_{mo}$  and  $3 \tau_{mo}$  respectively.

##### (b) External Step Disturbances

The transient responses of the capstan servo system when the motor is subjected to an external step disturbance for two different integrator gains are shown in Figs. 9 and 10. As expected, it takes longer for the system to return to its original steady-state position with the smaller integrator

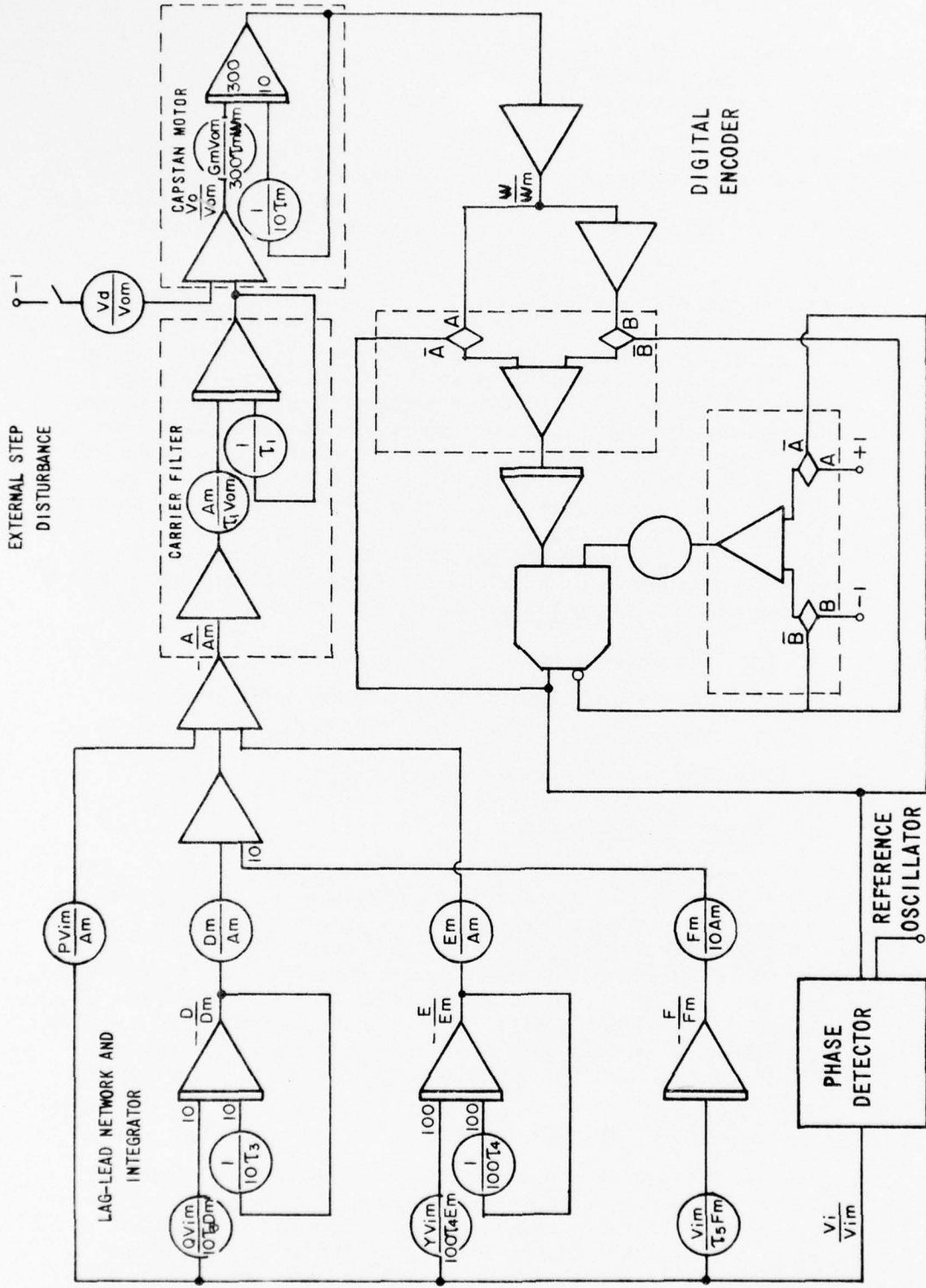

FIG. 4 ANALOG COMPUTER DIAGRAM



FIG. 5 START-UP TRANSIENTS OF THE CAPSTAN SERVO SYSTEM ( $T_5 = 1$ )

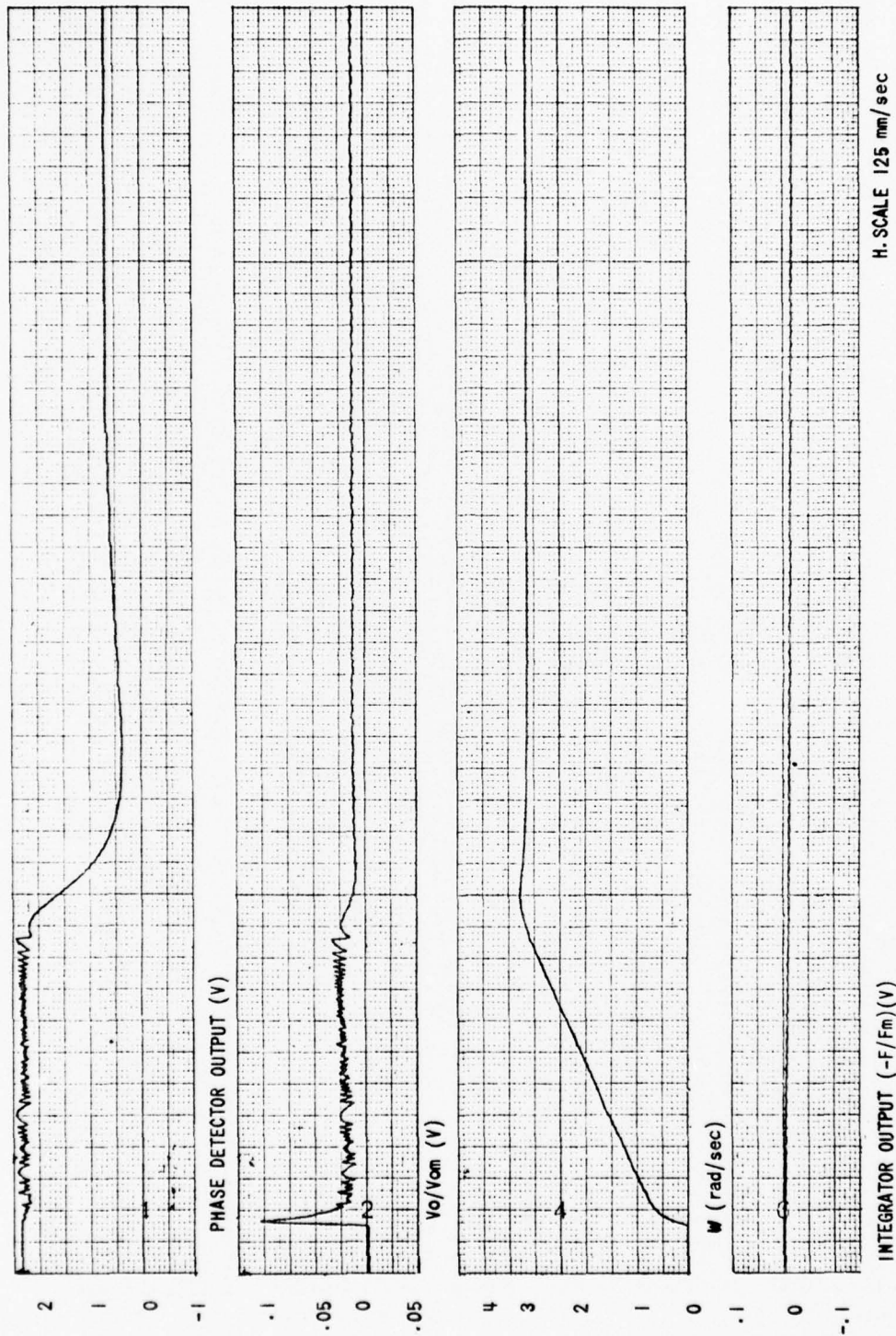

FIG. 6 START-UP TRANSIENTS OF THE CAPSTAN SERVO SYSTEM ( $\tau_5 = 10$ )

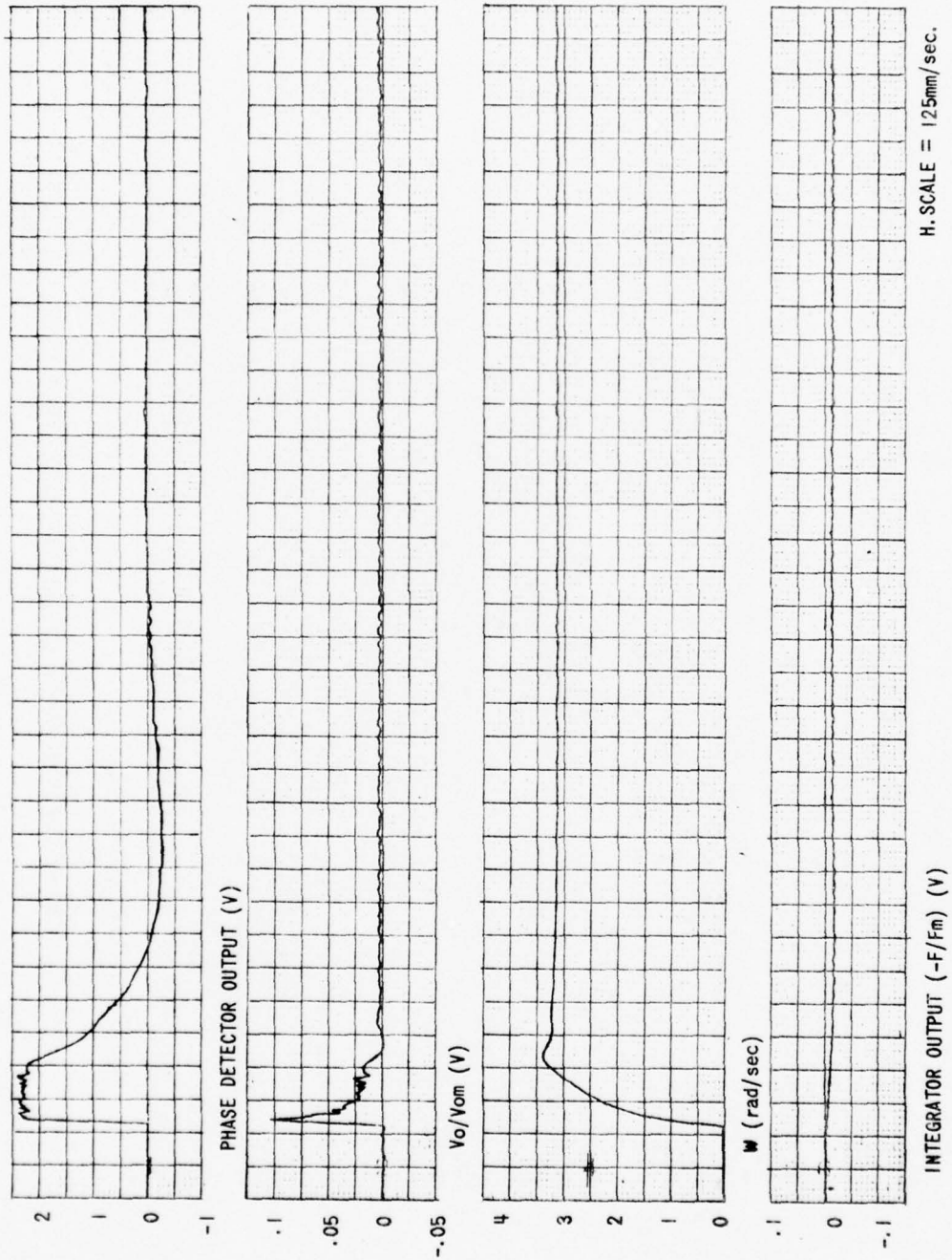

FIG. 7 START-UP TRANSIENTS OF THE CAPSTAN SERVO SYSTEM ( $T_5 = 1$ ,  $T_m = \frac{1}{3} T_{mo}$ )

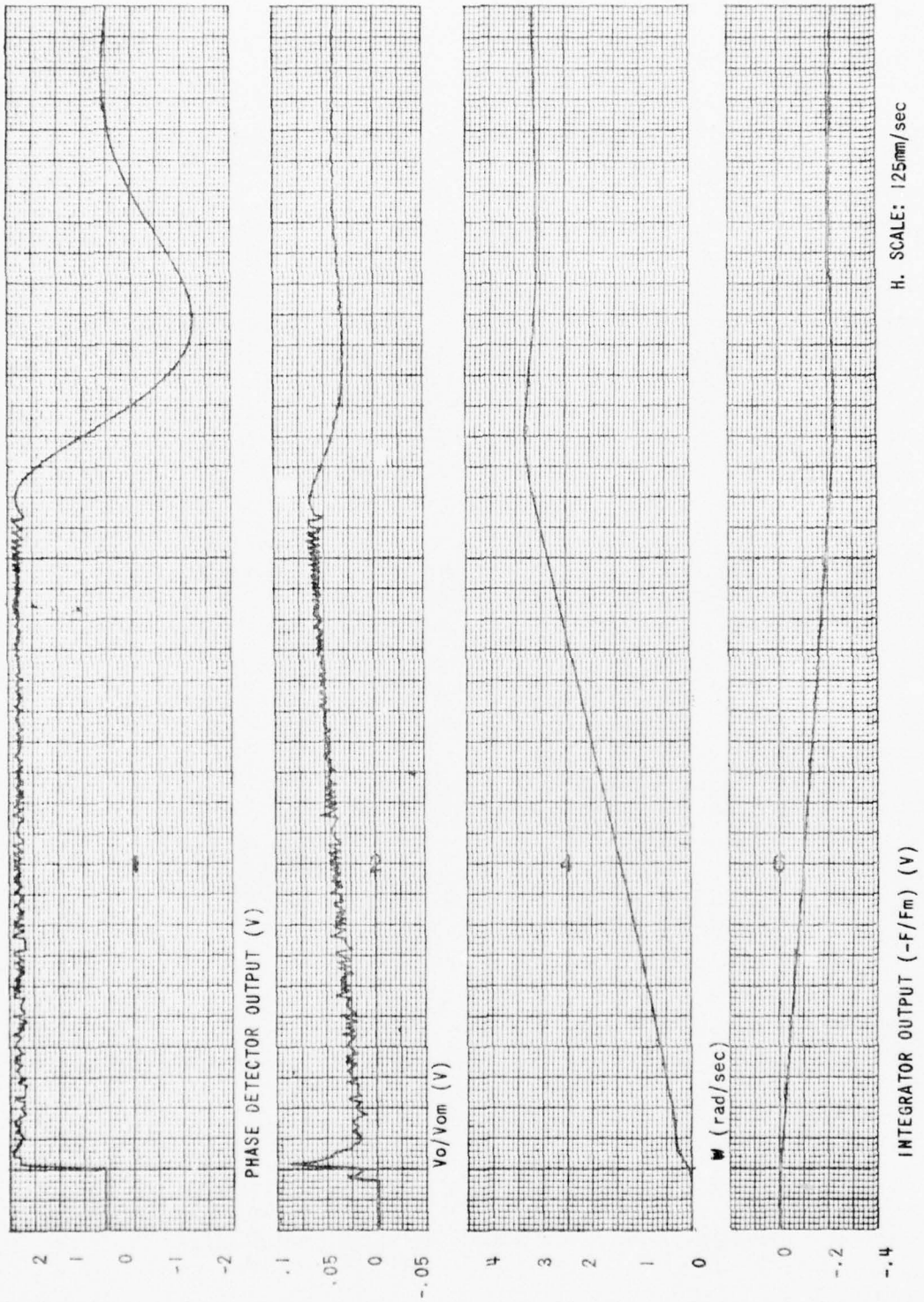
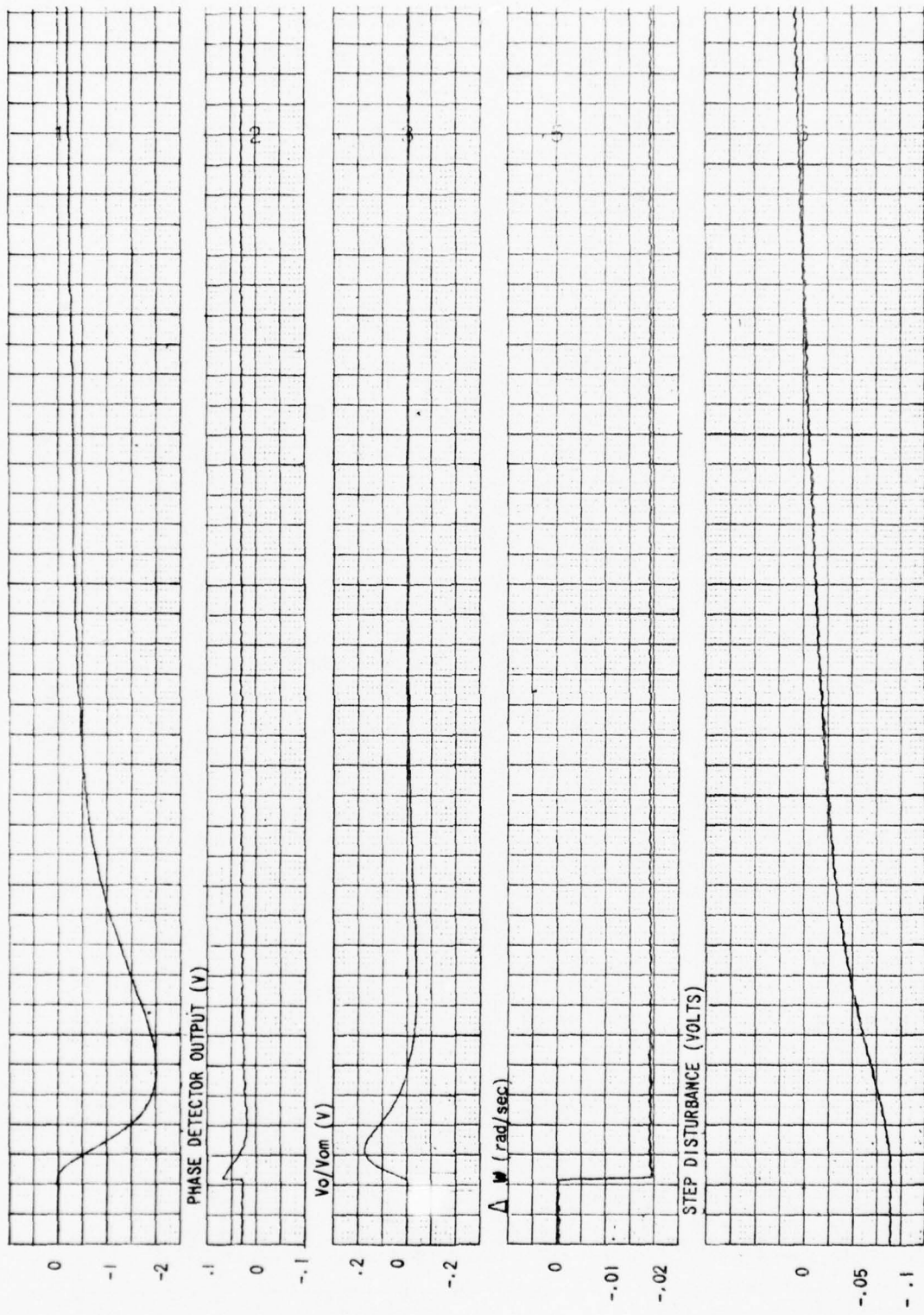

FIG. 8 START-UP TRANSIENTS OF THE CAPSTAN SERVO SYSTEM ( $T_E = 1$ ,  $T_m = 3 \tau_{m0}$ )



HORIZONTAL SCALE 125 mm/sec.

FIG.9 SYSTEM RESPONSE OF A STEP DISTURBANCE ( $T_5 = 1$ )

INTEGRATOR OUTPUT (-F/Fm) (V)

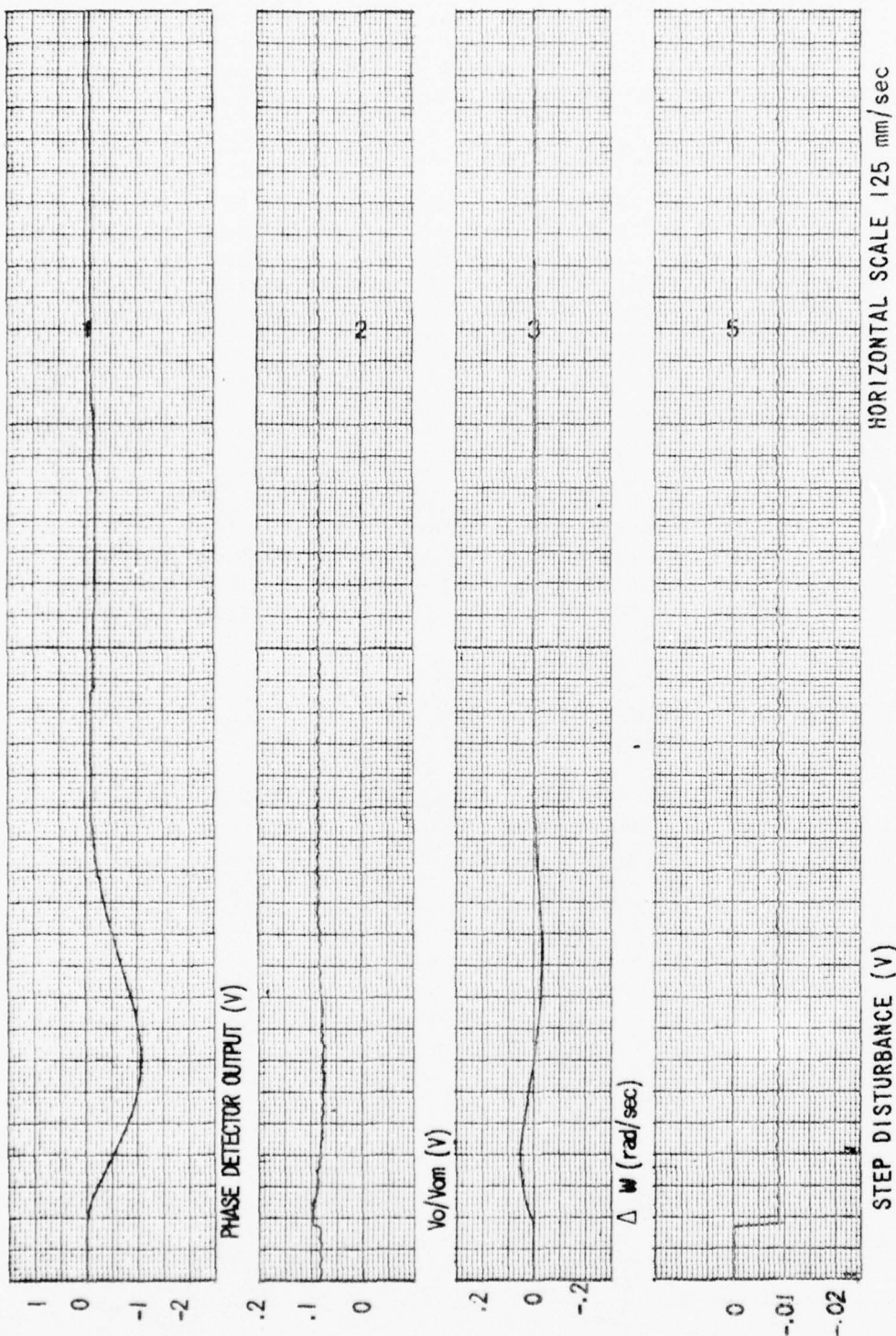

FIG. 11 SYSTEM RESPONSE OF A STEP DISTURBANCE ( $T_5 = 1, T_m = 3T_{mo}$ )

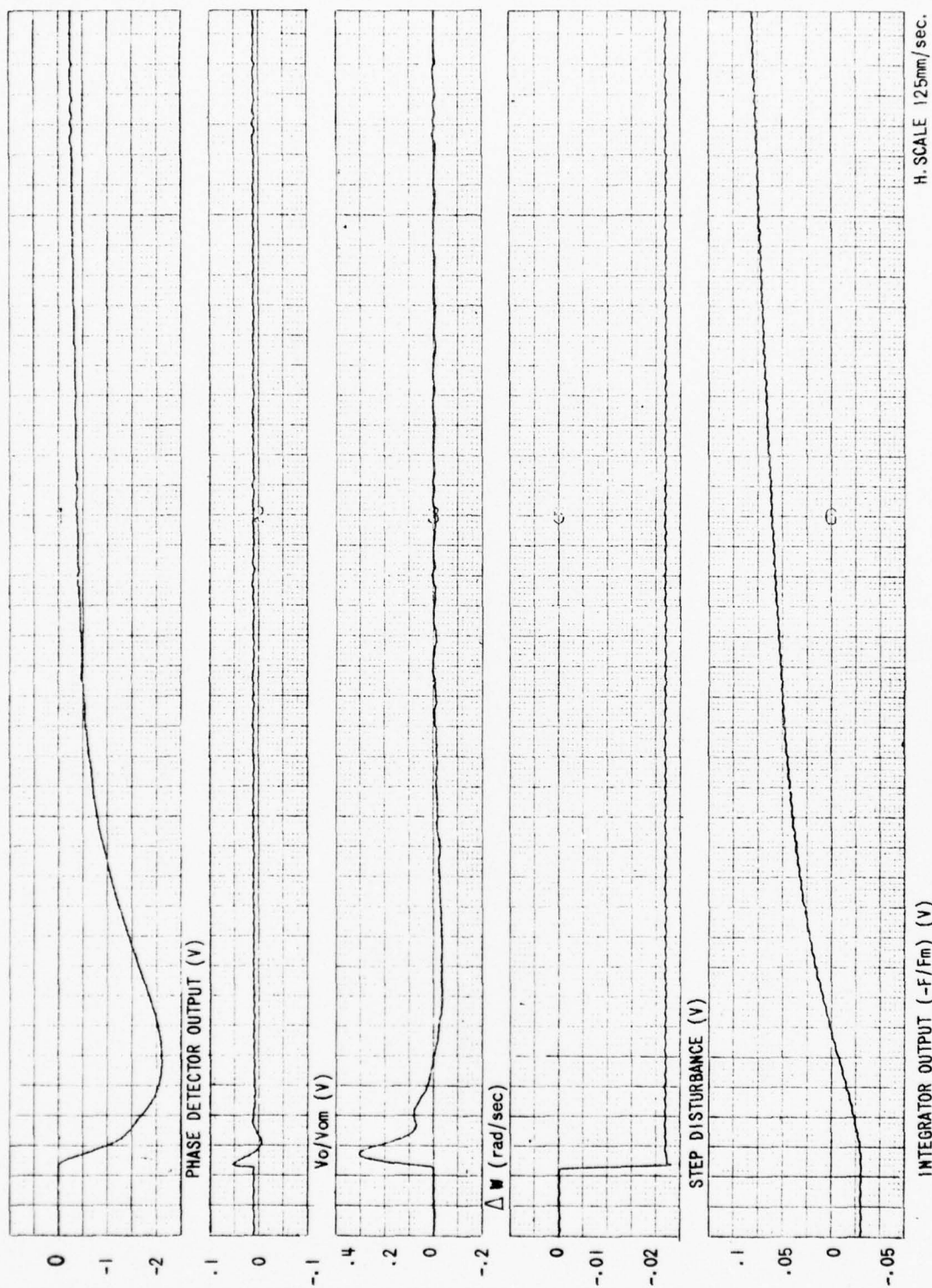
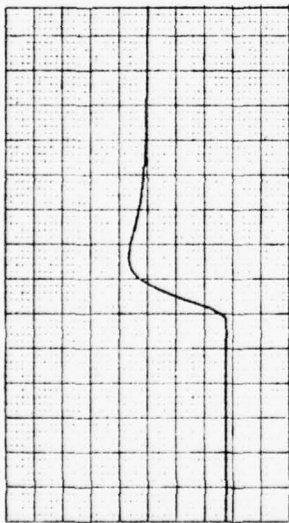
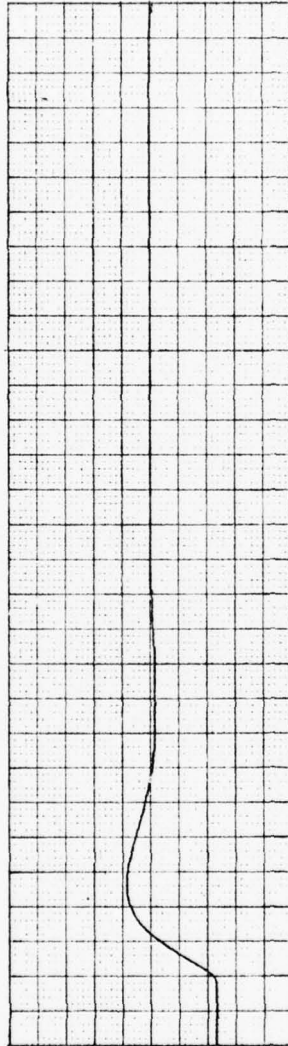

FIG. 12 SYSTEM RESPONSE OF A STEP DISTURBANCE ( $\tau_5 = 1, \tau_m = \frac{1}{3} \tau_{mo}$ )



(a) HORIZONTAL SCALE: 125 mm/sec



(b) HORIZONTAL SCALE: 125 mm/sec.

FIG. 13 SYSTEM RESPONSE TO A STEP INPUT

(a) DESIGN # 1,  $\tau_5 \approx 1$

(b) DESIGN # 2,  $\tau_5 \approx 1$

TABLE II

## External Step Disturbance Response

$\tau_5$	ANALOG COMPUTER SIMULATION		DIGITAL COMPUTER CALCULATION	
	$\Delta T/\Delta$ SLOT (Oz In/SLOT)	TIME (SEC) PEAK	$\Delta T/\Delta$ SLOT (Oz In/SLOT)	TIME (SEC) PEAK
1	1.08	0.145	0.82	0.15
10	1.06	0.168	0.76	0.17

### III. THE EFFECT OF OTHER COMPONENTS IN THE COMPLETE SERVO SYSTEM ON THE CAPSTAN SERVO PERFORMANCE

With the capstan servo system analysis completed, the next step was to analyse how other components affect its performance. To get an insight into the problem, a simplified symmetrical servo system was analysed and given in Appendix E. The net effect is taken care of through the modification of the capstan motor constants. The capstan motor thus experiences a bigger load with a different mechanical time constant given by the equations in the appendix.

The other variations in the system parameters such as average friction torque, film sticking and slippage etc. can be treated as external torque disturbances on the capstan motor.

### IV. TENSION AND REEL SERVOS

Four similar PMI type U12M4 motors were used for the reel and tension motors. The arrangement of the servo system is shown in Fig. 14 with the appropriate tensions on the film shown. Tension motors (2) and (4) were fed with constant current sources and are used to maintain the required tensions on the film. Tension motor (4) was also used to drive the servo system and to keep the difference in tension across the capstan small. The variations in film tension due to the change in film radii as it moved from

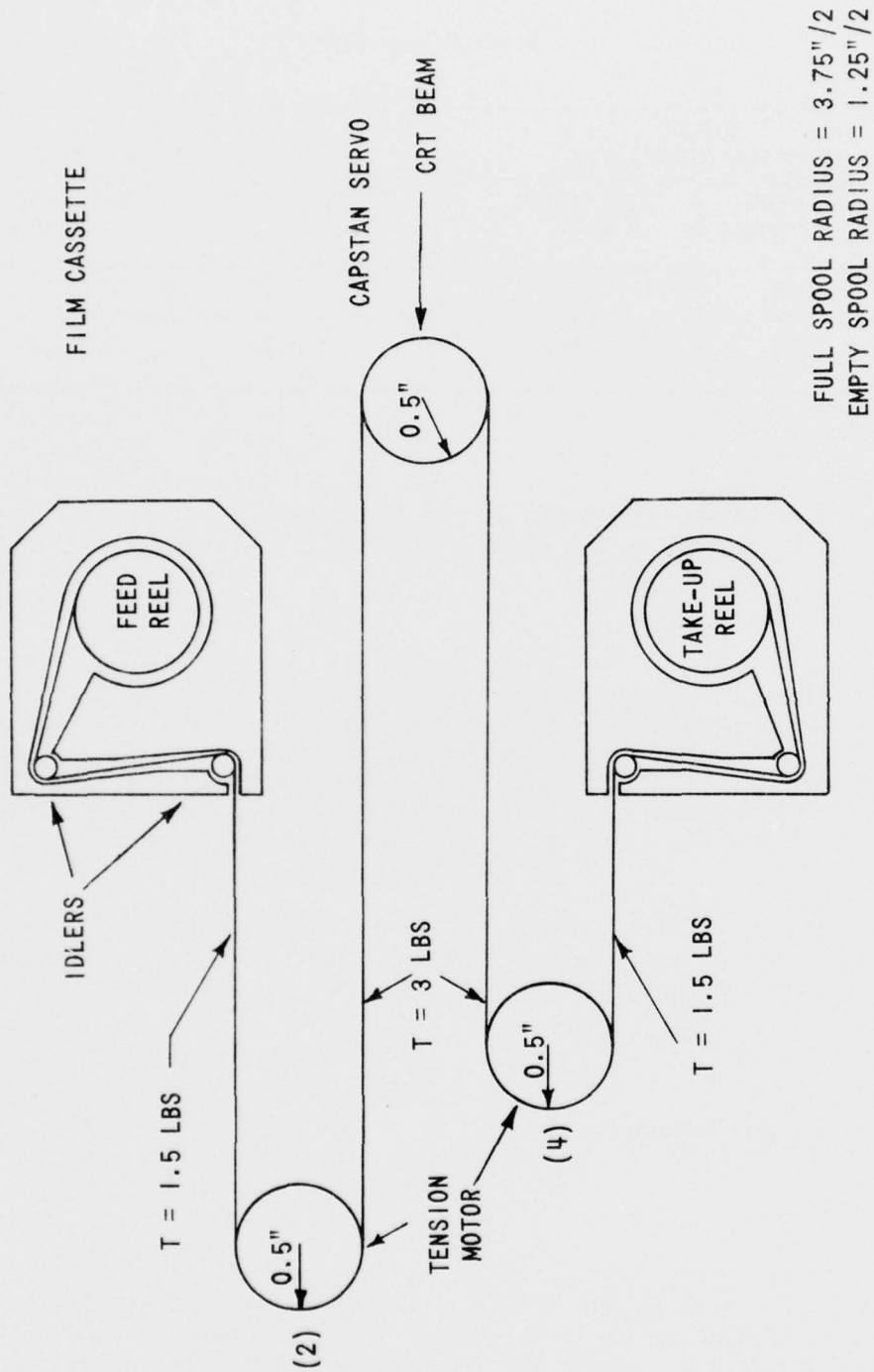

FIG.14 POSITIONAL ARRANGEMENT OF SERVO SYSTEM

one reel to another were compensated by controlling the currents to the reel motors accordingly. This was done by measuring indirectly the film radius (directly by measuring the angular velocity ( $\omega$ ),  $r \propto \frac{1}{\omega}$ ) and supplying drive current proportional to the film radius to each motor. The circuit implementation of this function was designed by M. McMillan of DREO and the circuitry diagram is shown in Fig. 15. An optical encoder was employed and the number of pulses generated is proportional to the angular velocity of the reel servo. The fifty percent duty cycle pulse train is then converted to a pulse train of short fixed width pulses by the monostable multivibrator. It is then applied to the RC integrating network and the output voltage is proportional to the angular velocity ( $\omega$ ). Finally, it is inverted by the divider and used to control the output current of the power amplifier supplying the reel motor.

#### V. TESTING AND EVALUATION OF COMPLETE SERVO SYSTEM

The complete servo system of design #1 was assembled and tested with the 5 inch wide, 150 ft. long roll of photographic film. The output from the bipolar power amplifier of the capstan control system was measured and plotted in Fig. 16. The turn-on sequence was to have the capstan system running before turning on the rest of the servo system. The steady-state phase error was measured to have a peak value equivalent to  $\pm 0.3$  of a slot with the capstan servo running alone. The main source of disturbance was found to originate from the low-frequency variation in friction as the capstan motor shaft rotated around its bearings. The small high frequency errors due to the nonuniformities in the disc pattern were attenuated by the loop filter and thus prevented from reaching the motor. When the complete servo system was turned on, the steady-state peak phase error was increased to  $\pm 1.2$  slots which was well below the allowable maximum phase error of  $\pm 8$  slots. The anticipated increase in the phase error was mainly due to the increase in disturbances coming from other parts of the system such as friction torque, film stickage, and disturbance coming from the reel control circuits. The friction between the steel shaft of the capstan motor and the film was so great that even with constant currents supplied to the reel servos, no film slippage occurred.

#### VI. CONCLUSIONS

The design of the servo system and the analysis of the capstan servo system using both the analog computer simulation combined with the breadboarded digital phase detector as well as digital computer calculations have been presented. A general theoretical analysis on how other parts in the servo

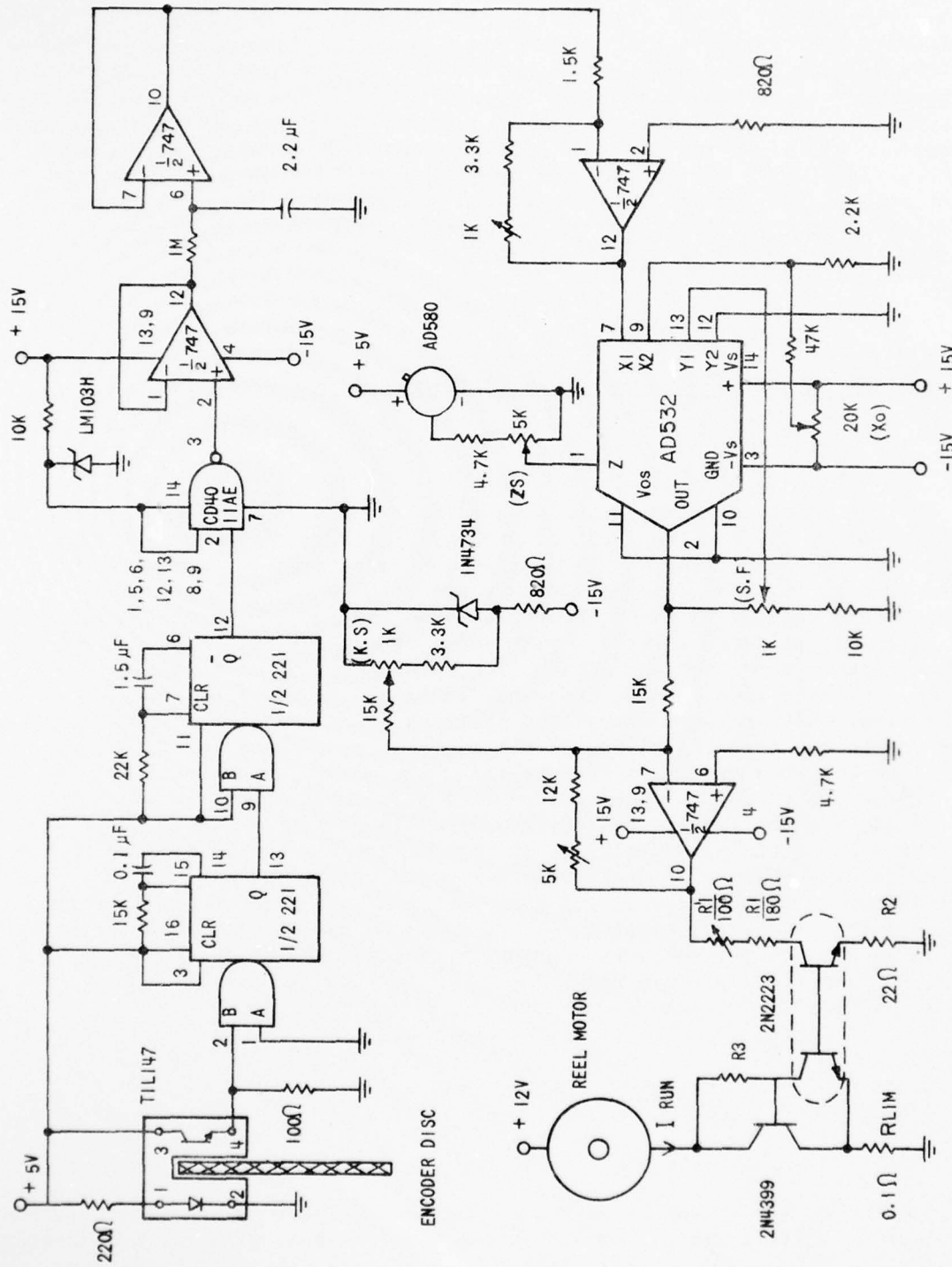

FIG. 15 REEL COMPENSATION CIRCUITRY

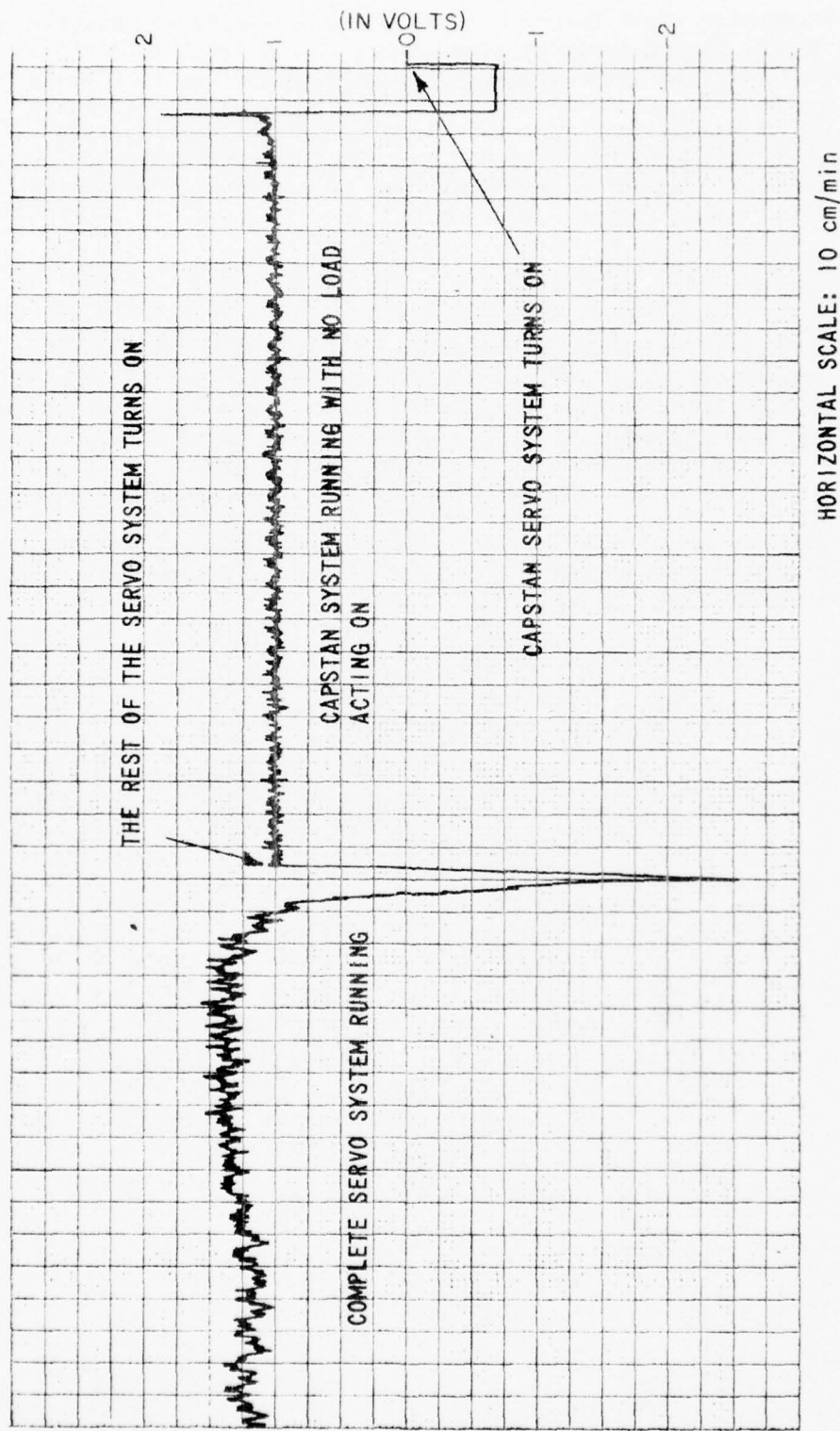

FIG. 16 SERVO SYSTEM PERFORMANCE CHARACTERISTICS  
(MEASUREMENT TAKEN FROM THE OUTPUT OF THE BIPOLAR POWER AMPLIFIER)

system affect the capstan servo response is also given. Using the capstan servo design #1 in the analog computer simulation, it was found that the capstan servo motor could tolerate a step torque disturbance up to 8 Oz-In and the system would still remain in lock. It was also found to be stable with at least  $\pm 27$  dB variation in the open-loop gain. It operated in a reasonably stable condition with the mechanical time constant varying from  $1/3 \tau_{mo}$  to  $3 \tau_{mo}$ . Both methods of analysis agree well with each other and thus provide a check on each other.

The complete servo system was built and integrated with other systems to form the optical recorder. The ultimate accuracy of the controlled output (the position on the film where the information is stored) in this servo system is limited only by the stability of the reference VCO, the precision of the slots on the encoder disc and the eccentricity of the capstan motor shaft. The capstan optical encoder disc has 5000 slots on it and a position resolution equaling one-sixteenth of a slot was obtained. Both tension motors were supplied with constant currents and the change in tension on the film due to the change in film radius was corrected by the reel control circuitry. The maximum steady-state phase error was found to be equivalent to about  $\pm 0.3$  of a slot with no load acting on the capstan motor. It increased to  $\pm 1.2$  slots with the complete servo system running and it was well below the designed maximum allowable error of  $\pm 8$  slots.

VII. REFERENCES

1. Dana F. Geiger "Velocity control of DC motors by use of phaselock servo techniques", Photocircuits Division, Kollmorgen Corporation, 1973.
2. J.L. Melsa and D.G. Schultz, Linear Control Systems, New York: McGraw-Hill, 1969.

APPENDIX A

SYSTEM DESIGN USING THE BODE METHOD

SYSTEM DESIGN USING THE BODE METHOD

The servo system to be designed is a type 2, proportional plus integral control, phase lock system. A block diagram representation is given below:

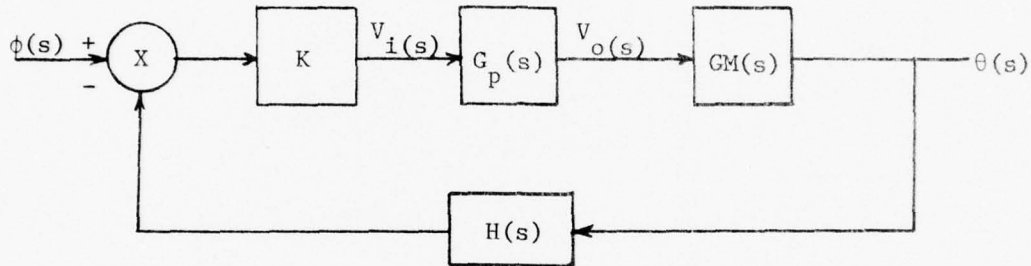

FIGURE A-1. SERVO SYSTEM BLOCK DIAGRAM

where

$$G_p(s) = \frac{1}{1 + \tau_1 s} \left[ \frac{(1 + \tau_2 s)^2}{(1 + \tau_3 s)(1 + \tau_4 s)} + \frac{1}{\tau_5 s} \right]$$

$$\frac{1}{1 + \tau_1 s}$$

- carrier filter transfer function

$$\frac{(1 + \tau_2 s)^2}{(1 + \tau_3 s)(1 + \tau_4 s)}$$

- lag-lead compensation transfer function

$$\frac{1}{\tau_5 s}$$

- integrator transfer function

$$H = 1$$

$$\phi(s)$$

- Reference phase input in motor shaft radians

$$\theta(s)$$

- Motor shaft angle

$$GM = \frac{G_m}{s(1 + s\tau_m)} \quad - \text{ Motor transfer function}$$

The open-loop transfer function

$$G = K G_p GM H$$

With the number of slots on the optical tachometer equal to 5000, the frequency output with the system running at steady-state is equal to 2500 Hz or 15.71 K rad/sec. To avoid 'sampled data lag', the bandwidth of the system must be at least five times less than the tachometer frequency. In other words, the optical tachometer has to sample at least five times faster than the system response time so that the phase lag introduced is negligible. If the phase lag introduced is small, the sampled-data system can be approximated accurately by a continuous-time solution.

Putting all the specifications in terms of the open-loop transfer function, we have

- (1) Low-frequency asymptote:

The input reference phase is a ramp function and to have zero steady-state velocity error, it must be a type two system; with two poles at the origin.

- (2) Middle-frequency specifications:

- (a) Any external disturbance on the system is expected to be of low-frequency nature. For a disturbing torque  $\Delta T$ , the motor voltage required to counteract it is

$$\Delta V_o = \frac{\Delta T r_a}{K_t}$$

and for a maximum phase error equivalent to four slots,

$$\Delta \theta = 4 \times \frac{2\pi}{5000} \text{ radians.}$$

The minimum gain of the open-loop (excluding the motor) required

$$\frac{\Delta \theta}{\Delta V_o} = K = \frac{5000 \Delta T r_a}{8 \pi K_t} \text{ at } \omega = 1 \text{ rad/sec}$$

For this particular motor design (The modified PMI TYPE U12 M4), choosing

$$\Delta T = 2 \text{ Oz.-In.}$$

$$r_a = 1 \Omega$$

$$k_t = 0.11016 \text{ N.m/a}$$

the gain required

$$K = 25.5 = 28 \text{ db} \quad \text{at } \omega = 1 \text{ rad/sec.}$$

The maximum phase error introduced by the disturbance is expected to be much higher because the speed of response of the system is not instantaneous.  $K$  is chosen to be 37 db and the overall open-loop gain must be greater than  $37 \text{ db} + 19.2 \text{ db} = 56.2 \text{ db}$ .

- (b) To avoid 'sampled data lag', the bandwidth of the closed-loop system must be much smaller than the frequency generated from the optical tachometer. The cross-over frequency gives a very good approximation to the closed-loop system bandwidth.
- (c) The main purpose of the lag-lead network is to compensate for the phase of the system for stability. To ensure a favorable phase margin, the slope should be  $-20 \text{ db/decade}$  at the cross-over frequency.

(3) High-frequency asymptote:

It is desirable to design a system which can reject the high-frequency noise generated in the system. One main source of noise is caused by the non-uniformity of the slots on the optical encoder and the block diagram is given below:

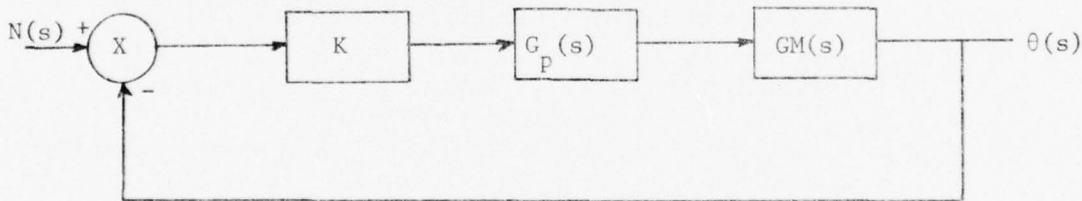

FIGURE A-2. BLOCK DIAGRAM WITH NOISE AS INPUT

By choosing the high-frequency noise rejection requirement that the noise at the output is reduced to 1% at  $\omega = 1000$  rad/sec, we have

$$\frac{|G(j\omega)|}{|1 + G(j\omega)|} \quad \omega = 1000 \quad \leq 0.01$$

or  $|G(j\omega)| \leq 0.01 \leq 40\text{db}$  at  $\omega = 1000$  rad/sec.

If the low-frequency-asymptote, middle-frequency gain and the high-frequency attenuation specifications are placed on the Bode plot as shown in Figure A-3, the general shape of the compensated transfer function becomes fairly well established. Two slightly different lag-lead networks are synthesized and they are designated as #1 and #2 respectively.

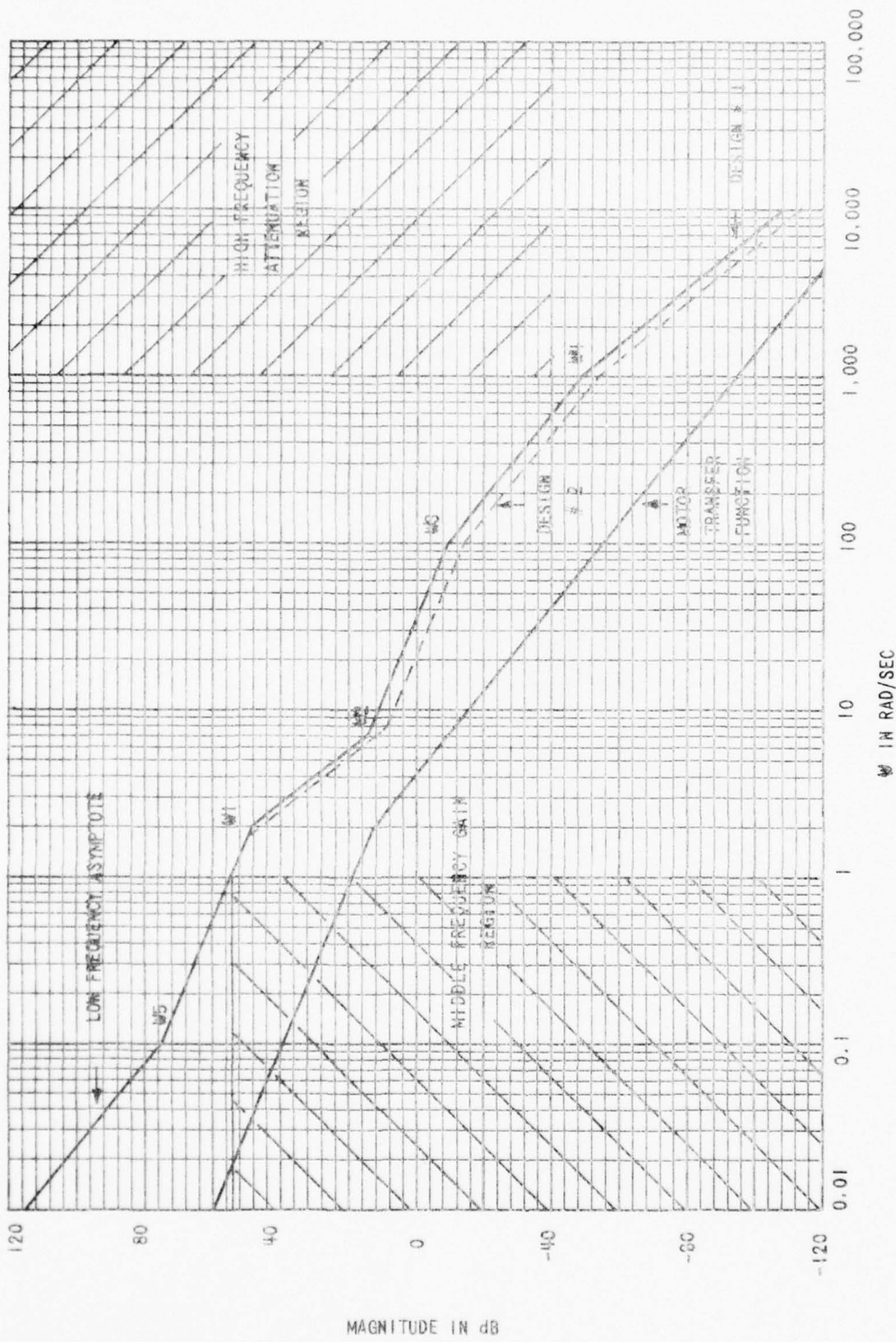

FIG. A-3 MAGNITUDE PLOTS OF G (jw) AND THE SPECIFICATIONS

APPENDIX B

THE MAGNITUDE AND PHASE PLOTS OF THE OPEN LOOP TRANSFER FUNCTION

THE MAGNITUDE AND PHASE PLOTS OF THE OPEN LOOP TRANSFER FUNCTION

Two sets of magnitude and phase plots are given in this appendix for the two designs. For each set, two different plots are drawn with the integrator gains equal to 1 and 0.1. The program was written by W.G. Thistle in the APL language. There are basically five subroutines as follows:

$$\text{MOTOR} = \frac{G_m}{j\omega(1 + j\omega T_m)}$$

$$\text{DET} = K = A \text{ (detector gain)}$$

$$\text{SAMPLE} = \text{Phase-lag introduced by the phase detector}$$

$$\phi = \frac{\omega}{2 \times \text{FC}}, \quad \text{FC} = \text{number of slots on encoder}$$

$$\text{LLI} = \text{lag-lead - integrator} = F(\tau_2, \tau_3, \tau_2, \tau_4, \tau_5)$$

$$\text{-FILT} = \text{Carrier filter} = F(\tau_1).$$

A set of motor constants and system parameters used in the program are tabulated in Table B-1. The magnitude and phase plots of the uncompensated open-loop transfer function with and without carrier filter are given in Fig. B-2 and B-1 respectively. Figs. B-3 through B-6 show how the gain and phase margins are improved and modified with the addition of a compensation and integrator network for the two different designs.



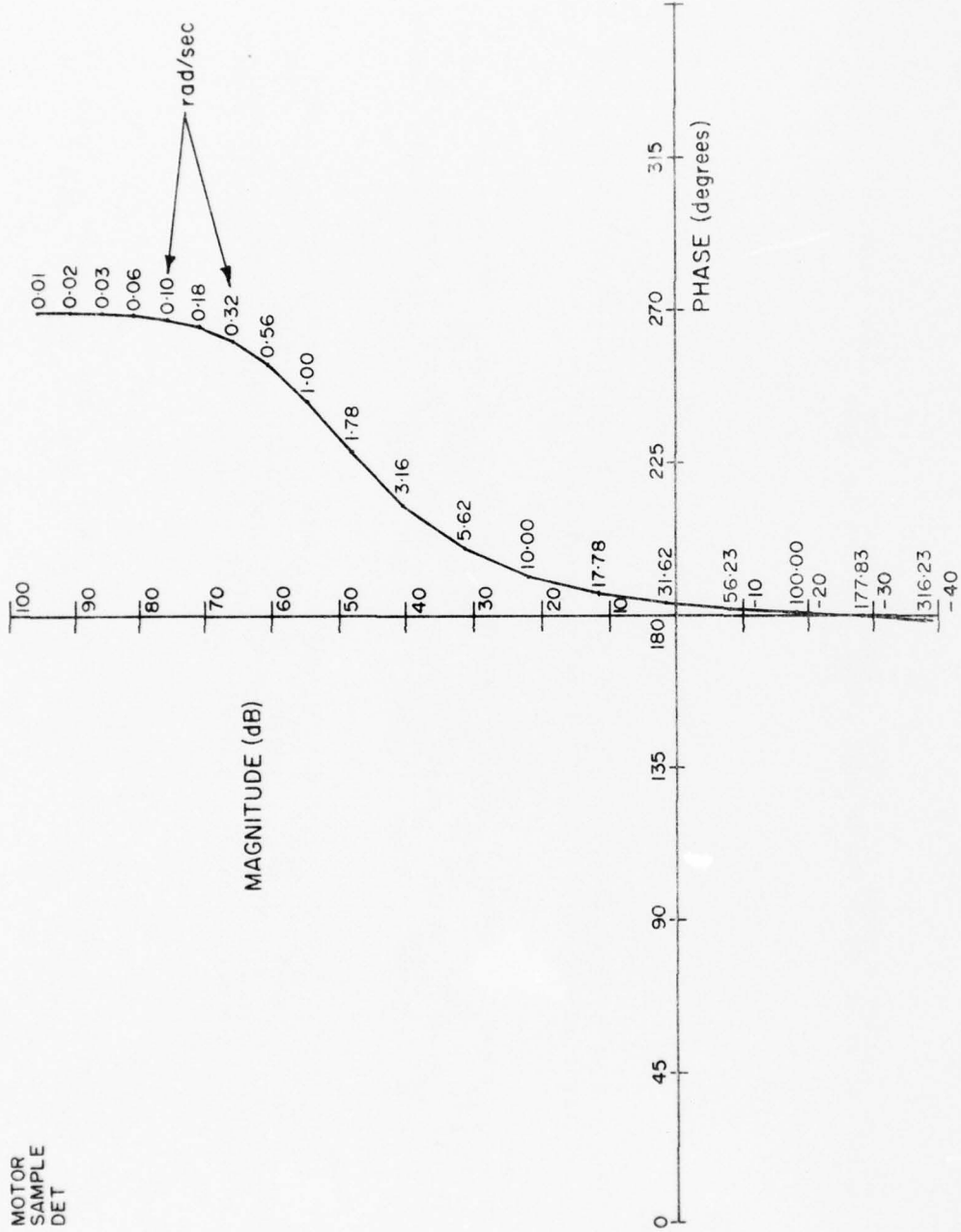

Figure B-1 Magnitude and Phase Plot of the Uncompensated Open-Loop Transfer Function without Carrier Filter.

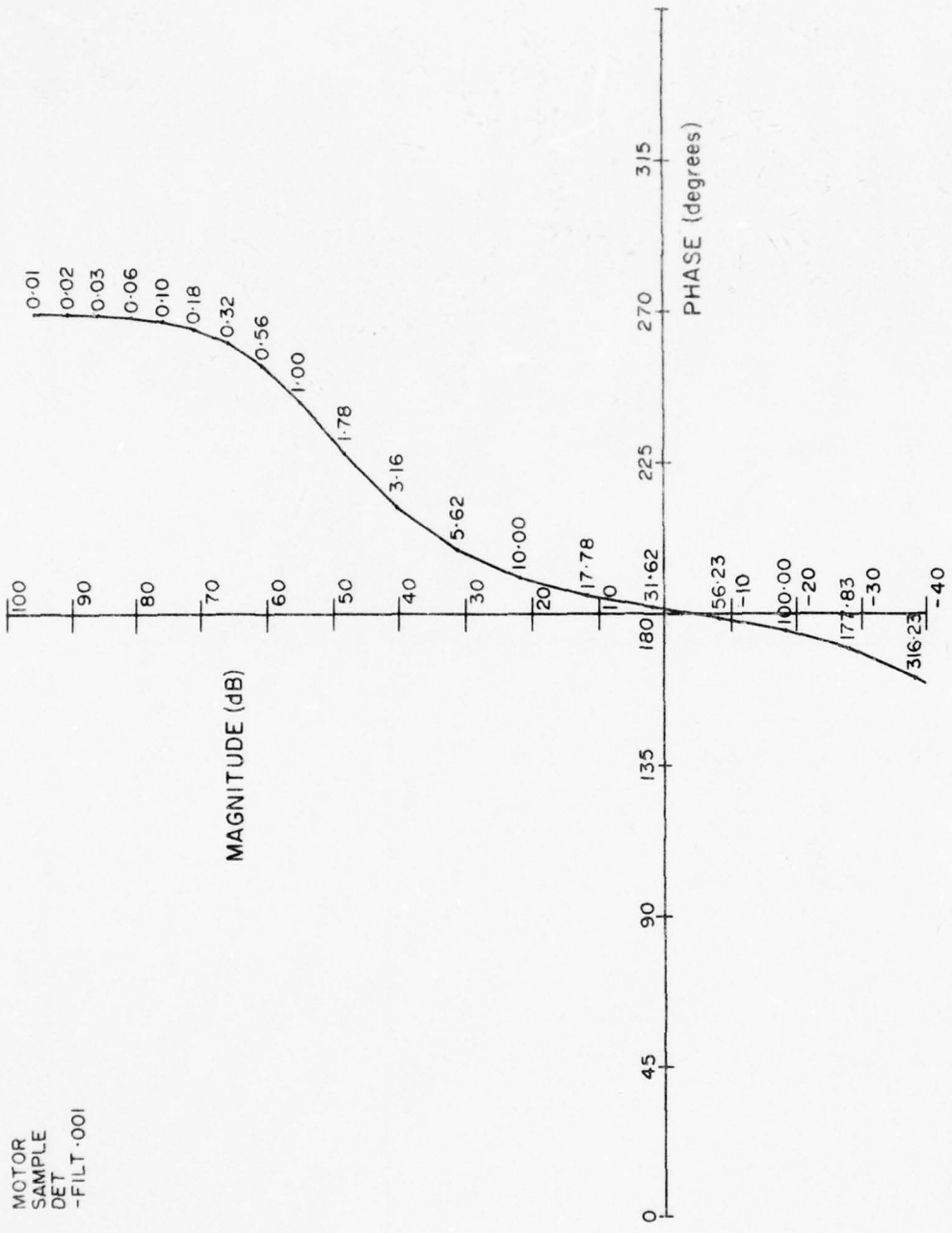

Figure B-2 Magnitude and Phase Plot of the Uncompensated Open-Loop Transfer Function with Carrier Filter.

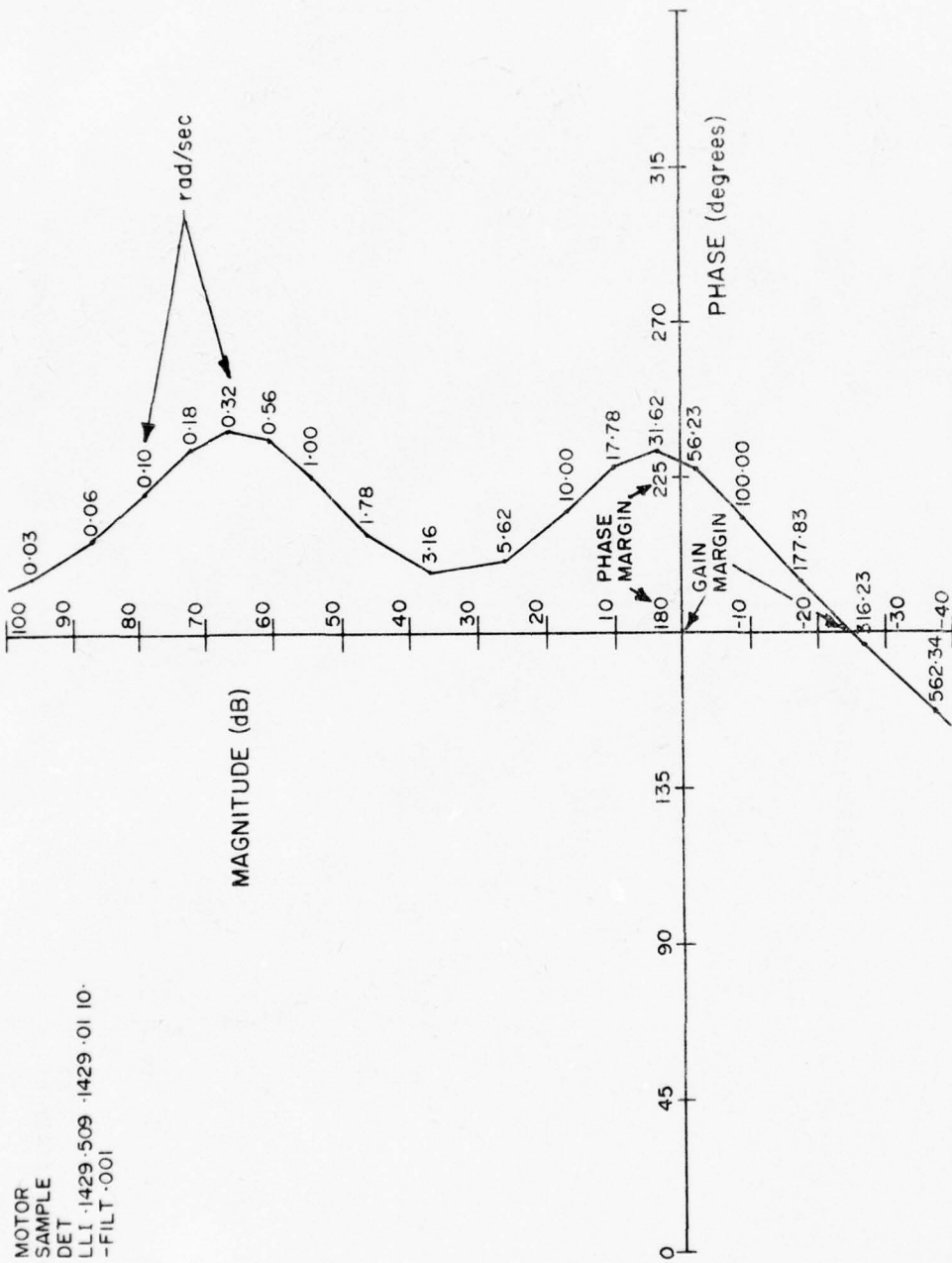

Figure B-3 Magnitude and Phase Plot of the Compensated Open-Loop Transfer Function (Design No. 1,  $T_s=10$ )

MOTOR  
 SAMPLE  
 DET  
 LLI .125 .667 .125 .01 1.  
 -FILT .001

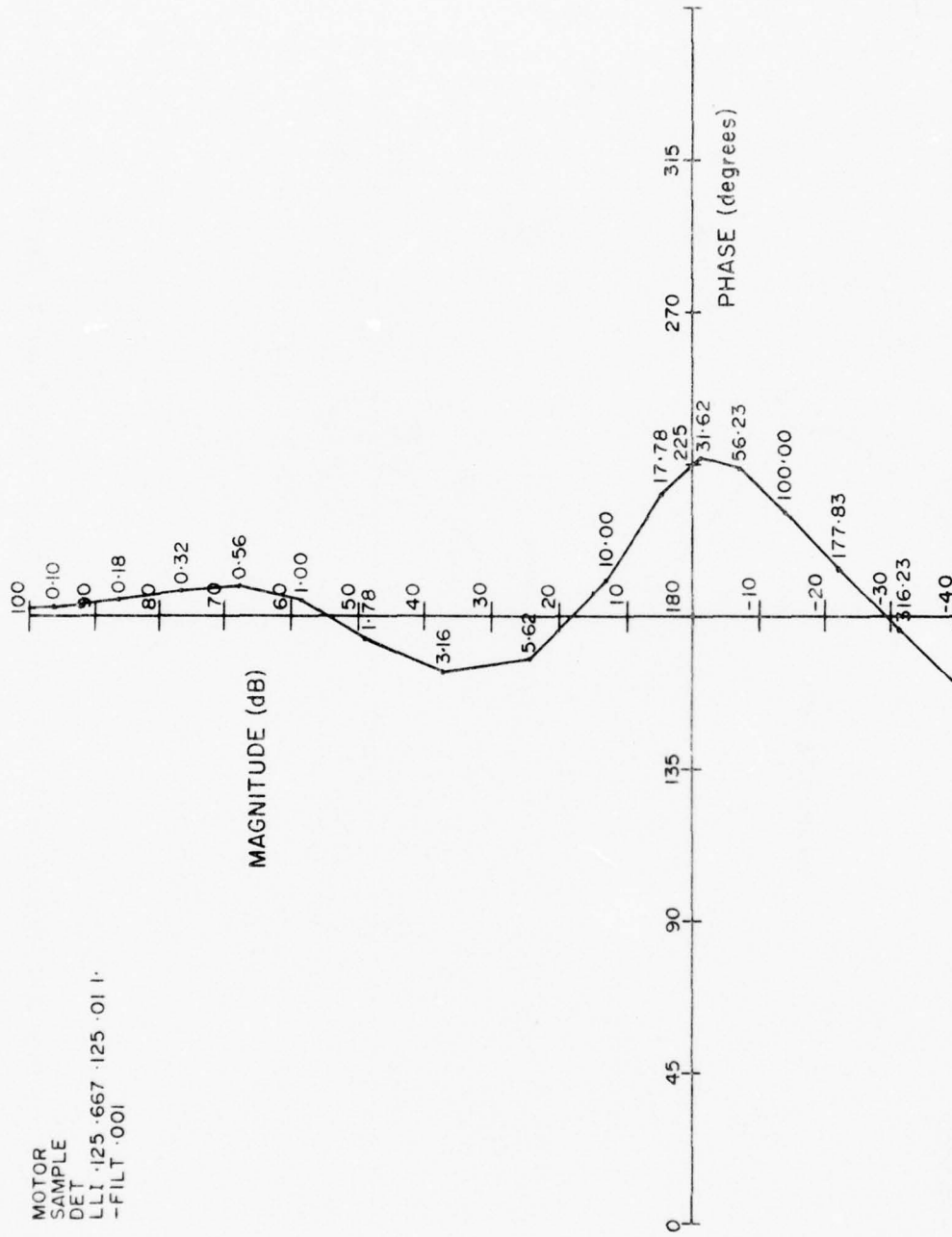

Figure B-4 Magnitude and Phase Plot of the Compensated Open-Loop Transfer Function (Design No. 1,  $T_5 = 1$ )

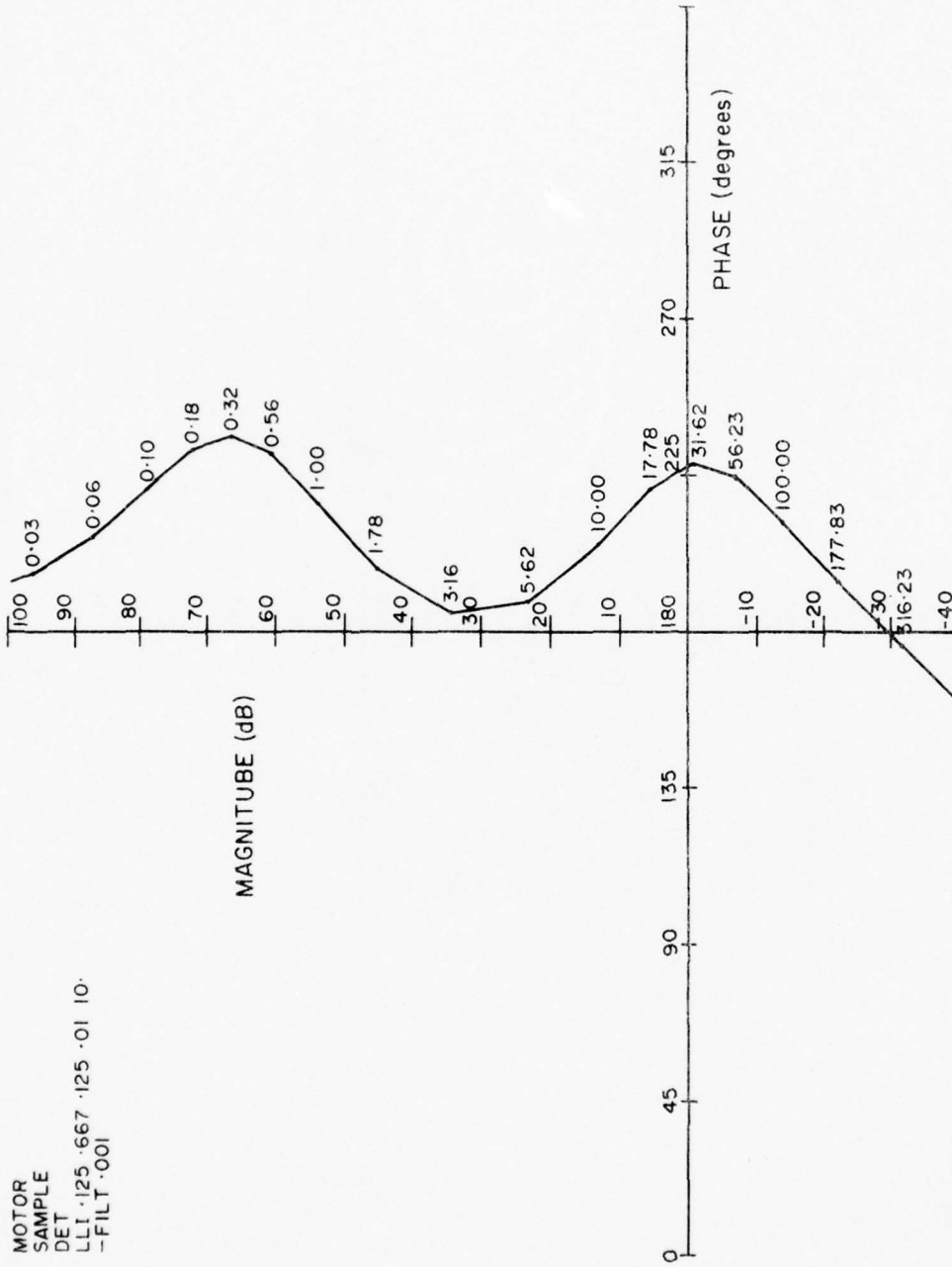

Figure B-5 Magnitude and Phase Plot of the Compensated Open-Loop Transfer Function (Design No 2,  $T_s=10$ )

MOTOR  
 SAMPLE  
 DET  
 LLI .1429 .509 .1429 .01 1.  
 -FILT .001

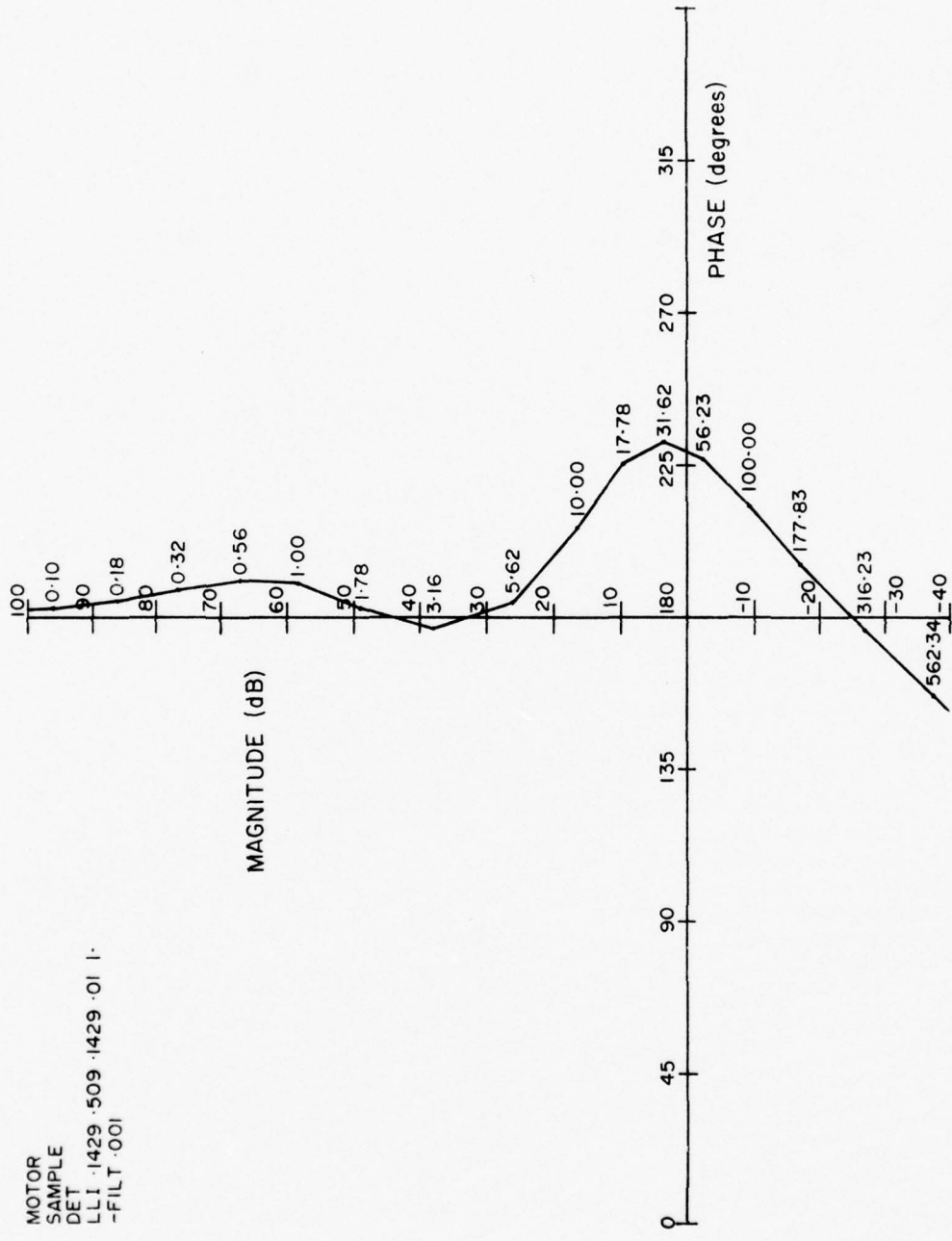

Figure B-6 Magnitude and Phase Plot of the Compensated Open-Loop Transfer Function (Design No. 2,  $T_s=1$ )

APPENDIX C

ANALOG COMPUTER MODELLING

ANALOG COMPUTER MODELLING

(1) SCALING

To prevent overloading any component in the analog computer, scaling is necessary. The angular velocity of the capstan motor is related to the output from the phase detector by the following transfer function:

$$\frac{\omega(s)}{V_i(s)} = \frac{1}{1 + \tau_1 s} \left[ \frac{(1 + \tau_2 s)^2}{(1 + \tau_3 s)(1 + \tau_4 s)} + \frac{1}{\tau_5 s} \right] \frac{G_m}{1 + \tau_m s}$$

$$\text{Let } \frac{V_o(s)}{V_i(s)} = \frac{1}{1 + \tau_1 s} \left[ \frac{(1 + \tau_2 s)^2}{(1 + \tau_3 s)(1 + \tau_4 s)} + \frac{1}{\tau_5 s} \right]$$

Expanding by partial-fraction-expansion method we have

$$\frac{V_o(s)}{V_i(s)} = \frac{1}{1 + \tau_1 s} \left[ P + \frac{Q}{1 + \tau_3 s} - \frac{Y}{1 + \tau_4 s} + \frac{1}{\tau_5 s} \right]$$

$$\text{where } P = \tau_2^2 / \tau_3 \tau_4$$

$$Q = \frac{\tau_3 - 2\tau_2 + \tau_2^2 / \tau_4}{\tau_3 - \tau_4} - \frac{\tau_2^2}{\tau_3 \tau_4}$$

$$Y = \left[ \frac{2\tau_2 - \tau_2^2 / \tau_4 - \tau_4}{\tau_3 - \tau_4} \right]$$

$$\begin{aligned} V_o(s) &= \frac{1}{1 + \tau_1 s} \left[ P V_i(s) + \frac{Q V_i(s)}{1 + \tau_3 s} - \frac{Y V_i(s)}{1 + \tau_4 s} + \frac{V_i(s)}{\tau_5 s} \right] \\ &= \frac{1}{1 + \tau_1 s} [P V_i(s) + D - E + F] \\ &= \frac{1}{1 + \tau_1 s} [A] \end{aligned}$$

Each term is normalized so that the input and output have a maximum value of unity. Take for example, the term D

$$D = \frac{Q}{1 + \tau_3 s} V_i$$

$$\tau_3 \dot{D} + D = Q V_i$$

$$\left[ \frac{\dot{D}}{D} \right] = \frac{Q V_{im}}{\tau_3 D_m} \left[ \frac{V_i}{V_{im}} \right] - \frac{1}{\tau_3} \left[ \frac{D}{D_m} \right]$$

where  $\left| \frac{V_i}{V_{im}} \right|$  and  $\left| \frac{D}{D_m} \right| \leq 1$

Carrying out the scaling for each stage, we get a computer block diagram as shown in Figure 4.

## (2) SIMULATION OF EXTERNAL STEP TORQUE DISTURBANCES ON THE CAPSTAN MOTOR

The motor transfer function is given by

$$\frac{\omega(s)}{V(s)} = \frac{G_m}{1 + \tau_m s}$$

For a step voltage  $V(s) = \frac{V_o}{s}$

$$\omega(t) = G_m V_o (1 - e^{-t/\tau_m}) \quad \text{--- (1)}$$

The motor equation when subjected to an external disturbance

$$J \frac{\partial^2 \theta}{\partial t^2} + B \frac{\partial \theta}{\partial t} = T$$

For a step torque  $T = \frac{T_o}{s}$

$$\omega(t) = \frac{T_o}{B} (1 - e^{-t/\tau_m}) \quad \text{--- (2)}$$

Comparing equations (1) and (2), the external step torque applied is related to the input voltage to the motor by

$$T_o = B G_m V_o \quad \text{--- (3)}$$

For this particular case, due to normalization the external torque ( $Oz$ -In) is related to the input voltage by

$$\begin{aligned}
 T_o &= B G_m \left( \frac{V_{om}}{\omega_m} \right) \left( \frac{V_o}{V_{om}} \right) \\
 &= 380.53 \left[ \frac{V_o}{V_{om}} \right] \quad \text{--- (4)}
 \end{aligned}$$

$$\text{Where } B = \frac{1}{R_m} = \frac{1}{5.85} \frac{\text{Oz-In}}{\text{RPM}}$$

$$G_m = 9.106 \text{ rad/volt}$$

$$V_{om}/\omega_m = 160/6.25$$

Another approximate approach in relating the voltage applied to the external disturbance torque on the motor is to use the terminal resistance of the motor to calculate the amount of current applied to the motor and then using the motor torque constant to calculate the corresponding external torque.

Using eq. (4) above and referring to Figs. 9 and 10 on pages 13 and 14 respectively, the external step torque responses for the two cases are given as follows:

(i) For  $\tau_5 = 1$

$$\begin{aligned}
 \Delta T \text{ (external step torque applied)} &= 380.53 \left( \frac{V_o}{V_{om}} \right) \text{ Oz-In} \\
 &= 380.53 \times 0.019 \text{ Oz-In} \\
 &= 7.23 \text{ Oz-In.}
 \end{aligned}$$

$$\begin{aligned}
 \Delta \text{ slots (maximum no. slipped at } t = 0.145 \text{ sec)} \\
 &= \frac{2.09V}{2.5V} \times 8 \text{ slots} \\
 &= 6.69 \text{ slots}
 \end{aligned}$$

$$\begin{aligned}
 \therefore \Delta T / \Delta \text{ slots} &= \frac{7.23 \text{ Oz-In}}{6.69 \text{ slots}} \\
 &= 1.08 \text{ Oz-In/slot}
 \end{aligned}$$

(ii) For  $\tau_5 = 10$

$$\begin{aligned}\Delta T &= 380.53 \times 0.02 \text{ Oz-In} \\ &= 7.61 \text{ Oz-In}\end{aligned}$$

$$\begin{aligned}\Delta \text{ slots}(t = 0.168 \text{ sec.}) &= \frac{2.25V}{2.5V} \times 8 \text{ slots} \\ &= 7.2 \text{ slots}\end{aligned}$$

$$\begin{aligned}\therefore \Delta T / \Delta \text{ slots} &= \frac{7.61}{7.2} \text{ Oz-In/slot} \\ &= 1.06 \text{ Oz-In/slot}\end{aligned}$$

The above results for the two cases are tabulated in Table II on page 19.

### (3) STEP-FUNCTION RESPONSE

The step function response for design #1 with  $\tau_5 = 1$  is plotted in Fig. 13(a), page 18. The percent overshoot (at  $t = 0.068$  sec) was measured to be 25% and is tabulated in Table I on page 15.

APPENDIX D

DIGITAL COMPUTER CALCULATIONS

DIGITAL COMPUTER CALCULATIONS

(1) STEP-FUNCTION RESPONSE OF THE SYSTEM

The transfer function relating the input to the output motor shaft angle is given by

$$\frac{\theta(s)}{\phi(s)} = \frac{G(s)}{1 + G(s)} = \frac{\frac{K}{1 + \tau_1 s} \left[ \frac{(1 + \tau_2 s)^2}{(1 + \tau_3 s)(1 + \tau_4 s)} + \frac{1}{\tau_5 s} \right] \frac{G_m}{s(1 + s\tau_m)}}{1 + \frac{K}{1 + \tau_1 s} \left[ \frac{(1 + \tau_2 s)^2}{(1 + \tau_3 s)(1 + \tau_4 s)} + \frac{1}{\tau_5 s} \right] \frac{G_m}{s(1 + s\tau_m)}}$$

$$= \frac{KG_m [(1 + \tau_2 s)^2 \tau_5 s + (1 + \tau_3 s)(1 + \tau_4 s)]}{\tau_5 s^2 (1 + s\tau_m) (1 + \tau_1 s) (1 + \tau_3 s) (1 + \tau_4 s) + KG_m [(1 + \tau_2 s)^2 \tau_5 s + (1 + \tau_3 s)(1 + \tau_4 s)]}$$

For a unit-step function response,  $\phi(s) = \frac{1}{s}$ , the output  $\theta(s)$  is given by

$$\theta(s) = \frac{KG_m [(1 + \tau_2 s)^2 \tau_5 s + (1 + \tau_3 s)(1 + \tau_4 s)]}{\tau_5 s^2 (1 + s\tau_m) (1 + \tau_1 s) (1 + \tau_3 s) (1 + \tau_4 s) + KG_m [(1 + \tau_2 s)^2 \tau_5 s + (1 + \tau_3 s)(1 + \tau_4 s)]} \cdot \frac{1}{s}$$

and  $\theta(t) = L^{-1}[\theta(s)]$

The unit-step function responses for the two different compensation designs are shown in the following pages. Table D-1 gives a listing of the computer program written in Fortran IV language. The unit step responses for the two different designs are plotted in Figs. D-1 through D-4 and tabulated in Tables D-2 through D-5. From Tables D-2 and D-3 for design #1, the percent overshoots for the two cases using extrapolation are given below and tabulated in Table I on page 15.

(i) For  $\tau_5 = 1$

% overshoot = 27.5 at  $t_p = 0.065$  sec.

(ii) For  $\tau_5 = 10$

% overshoot = 26 at  $t_p = 0.065$  sec.

TABLE D-1 COMPUTER PROGRAM OF THE UNIT-STEP-FUNCTION RESPONSE

```

1.000 COMPLEX R,S,R1,ANUM,A,TRES
2.000 DIMENSION Z(102),Y(102),XCOF(7),ROOTR(6),ROOTI(6),R(7),A(7)
3.000 Z(1)=101.0 ; Y(1)=101.0
4.000 H=.5
5.000 AK=69.18
6.000 GM=9.106
7.000 T1=.001
8.000 T2=.1429
9.000 T3=.509
10.000 T4=.01
11.500 DO 50 J=1,2
11.000 T5=(J-1)*H. +J
12.000 TM=.509
13.000 XCOF(1)=AK*GM
14.000 XCOF(2)=AK*GM*(T3+T4+T5)
15.000 XCOF(3)=T5+AK*GM*(2.*T2*T5+T3*T4)
16.000 XCOF(4)=T5*(T1+T3+T4+TM+AK*GM*T2*T2)
17.000 XCOF(5)=T3*T4*T5+T1*TM*T5+(T3+T4)*(T1+TM)*T5
18.000 XCOF(6)=T1*T5*TM*(T3+T4) +T3*T4*T5*(T1+TM)
19.000 XCOF(7)=T1*T3*T4*T5*TM
20.000 CALL POLYROOT (XCOF,COF,M,ROOTR,ROOTI,IER)
23.000 DO 30 I=1,6
24.000 R(I+1)=CMPLX(ROOTR(I),ROOTI(I))
25.000 30 CONTINUE
26.000 R(1)=CMPLX(0.,0.)
27.000 DO 31 N=1,7
28.000 R1=R(N)
29.000 R(N)=R(1)
30.000 S=R1
31.000 ANUM=AK*GM*((1.+T2*S)**2*T5*S+(1.+T3*S)*(1.+T4*S))
32.000 A(N)=ANUM/((S-R(2))*(S-R(3))*(S-R(4))
33.000 1 *(S-R(5))*(S-R(6))*(S-R(7)))/XCOF(7)
34.000 R(N)=R1
37.000 31 CONTINUE
40.000 DO 32 K=1,101
41.000 T=(K-1)/100.
42.000 TRES=A(1)*CEXP(R(1)*T) +A(2)*CEXP(R(2)*T) +A(3)*CEXP(R(3)*T)
43.000 1 +A(4)*CEXP(R(4)*T) +A(5)*CEXP(R(5)*T) +A(6)*CEXP(R(6)*T)
44.000 2 +A(7)*CEXP(R(7)*T)
45.000 Z(K+1)=T
46.000 Y(K+1)=CABS(TRES)
47.000 WRITE(2,11) Z(K+1),Y(K+1),TRES
48.000 11 FORMAT(4E20.4)
49.000 32 CONTINUE
50.000 CALL INITT(240)
51.000 CALL BITTT
52.000 CALL CHECK(Z,Y)
53.000 CALL DSPLAY(Z,Y)
53.500 50 CONTINUE
54.000 CALL FINITT(0,700)
55.000 STOP
56.000 END
57.000 X

```

THIS PAGE IS BEST QUALITY REPRODUCTION  
FROM COPY FURNISHED TO DDC

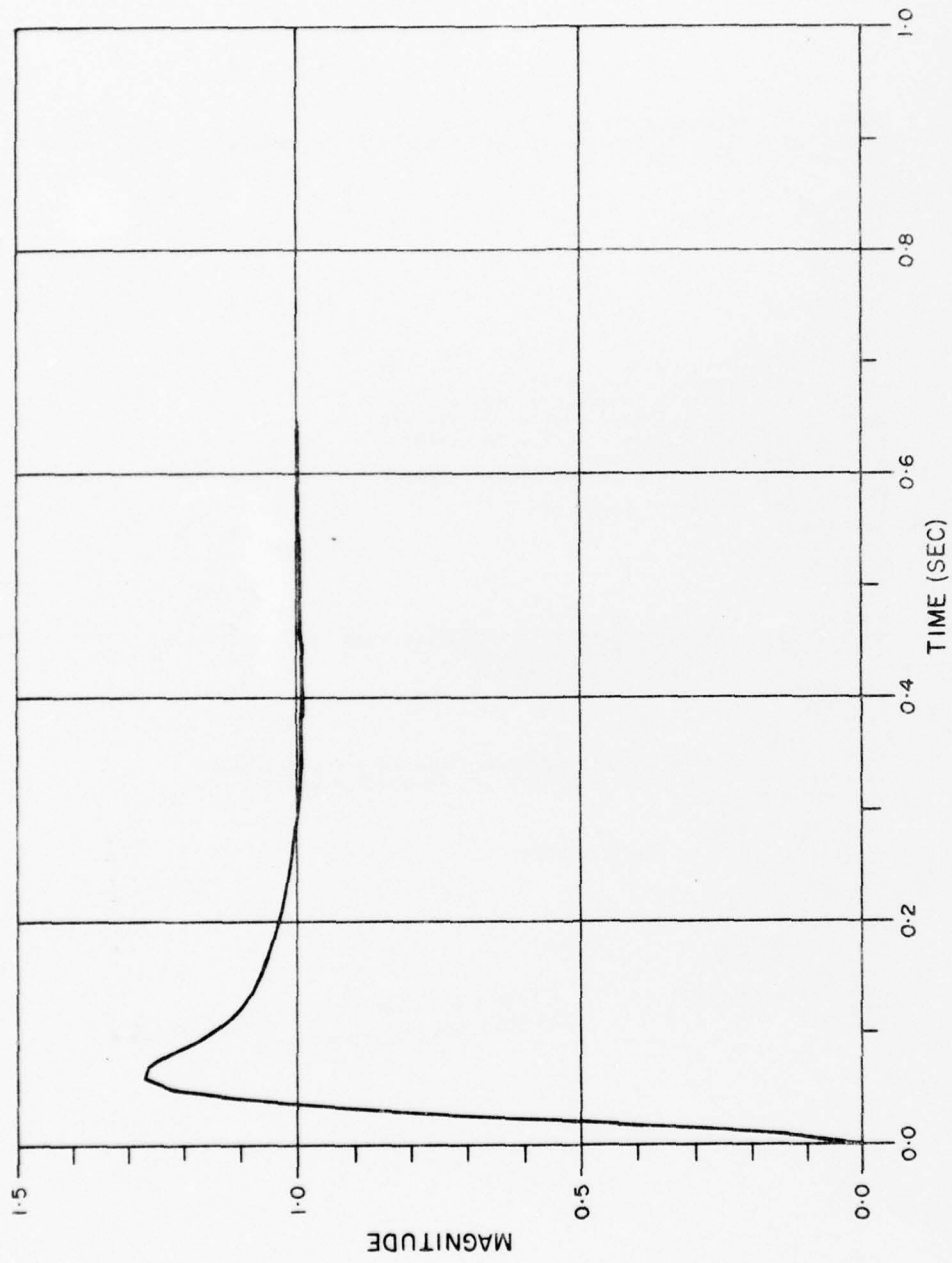

Figure D-1 Unit Step-Function Response (Design No. 1,  $\tau_s = 1$ )

TABLE D-2 UNIT STEP FUNCTION RESPONSE (DESIGN #1,  $T_5 = 1$ )

TIME (SEC)	MAGNITUDE (ABS)	REAL	IMAGINARY
.0000E 00	.4475E-07	.0000E 00	--.4475E-07
.1000E-01	.1549E 00	.1549E 00	.1825E-06
.2000E-01	.5014E 00	.5014E 00	.1713E-06
.3000E-01	.8407E 00	.8407E 00	.1005E-06
.4000E-01	.1085E 01	.1085E 01	.2975E-07
.5000E-01	.1221E 01	.1221E 01	--.3730E-07
.6000E-01	.1270E 01	.1270E 01	--.1081E-06
.7000E-01	.1263E 01	.1263E 01	--.1155E-06
.8000E-01	.1230E 01	.1230E 01	--.1379E-06
.9000E-01	.1189E 01	.1189E 01	--.1453E-06
1.0000E 00	.1152E 01	.1152E 01	--.1491E-06
1.1000E 00	.1123E 01	.1123E 01	--.1453E-06
1.2000E 00	.1101E 01	.1101E 01	--.1491E-06
1.3000E 00	.1085E 01	.1085E 01	--.1565E-06
1.4000E 00	.1074E 01	.1074E 01	--.1565E-06
1.5000E 00	.1065E 01	.1065E 01	--.1640E-06
1.6000E 00	.1057E 01	.1057E 01	--.1677E-06
1.7000E 00	.1050E 01	.1050E 01	--.1714E-06
1.8000E 00	.1044E 01	.1044E 01	--.1751E-06
1.9000E 00	.1038E 01	.1038E 01	--.1789E-06
2.0000E 00	.1032E 01	.1032E 01	--.1789E-06
2.1000E 00	.1026E 01	.1026E 01	--.1826E-06
2.2000E 00	.1021E 01	.1021E 01	--.1863E-06
2.3000E 00	.1017E 01	.1017E 01	--.1863E-06
2.4000E 00	.1013E 01	.1013E 01	--.1900E-06
2.5000E 00	.1010E 01	.1010E 01	--.1938E-06
2.6000E 00	.1007E 01	.1007E 01	--.1938E-06
2.7000E 00	.1004E 01	.1004E 01	--.1938E-06
2.8000E 00	.1002E 01	.1002E 01	--.1975E-06
2.9000E 00	.1000E 01	.1000E 01	--.1975E-06
3.0000E 00	.9985E 00	.9985E 00	--.2012E-06
3.1000E 00	.9971E 00	.9971E 00	--.2012E-06
3.2000E 00	.9959E 00	.9959E 00	--.2012E-06
3.3000E 00	.9950E 00	.9950E 00	--.2012E-06
3.4000E 00	.9942E 00	.9942E 00	--.2012E-06
3.5000E 00	.9936E 00	.9936E 00	--.2012E-06
3.6000E 00	.9931E 00	.9931E 00	--.2012E-06
3.7000E 00	.9927E 00	.9927E 00	--.2012E-06
3.8000E 00	.9925E 00	.9925E 00	--.2049E-06
3.9000E 00	.9923E 00	.9923E 00	--.2012E-06
4.0000E 00	.9923E 00	.9923E 00	--.2049E-06
4.1000E 00	.9923E 00	.9923E 00	--.2049E-06
4.2000E 00	.9923E 00	.9923E 00	--.2012E-06
4.3000E 00	.9924E 00	.9924E 00	--.2049E-06
4.4000E 00	.9926E 00	.9926E 00	--.2012E-06
4.5000E 00	.9928E 00	.9928E 00	--.2049E-06
4.6000E 00	.9930E 00	.9930E 00	--.2038E-06
4.7000E 00	.9933E 00	.9933E 00	--.2035E-06
4.8000E 00	.9935E 00	.9935E 00	--.2035E-06
4.9000E 00	.9938E 00	.9938E 00	--.2035E-06
5.0000E 00	.9941E 00	.9941E 00	--.2033E-06
5.1000E 00	.9944E 00	.9944E 00	--.2033E-06
5.2000E 00	.9947E 00	.9947E 00	--.2031E-06
5.3000E 00	.9950E 00	.9950E 00	--.2033E-06
5.4000E 00	.9953E 00	.9953E 00	--.2031E-06
5.5000E 00	.9955E 00	.9955E 00	--.2031E-06
5.6000E 00	.9958E 00	.9958E 00	--.2028E-06
5.7000E 00	.9961E 00	.9961E 00	--.2028E-06
5.8000E 00	.9964E 00	.9964E 00	--.2028E-06
5.9000E 00	.9966E 00	.9966E 00	--.2026E-06
6.0000E 00	.9969E 00	.9969E 00	--.2026E-06

THIS DATA IS BEST QUALITY AVAILABLE  
 FROM GPOY PRINTING OFFICE: 1964

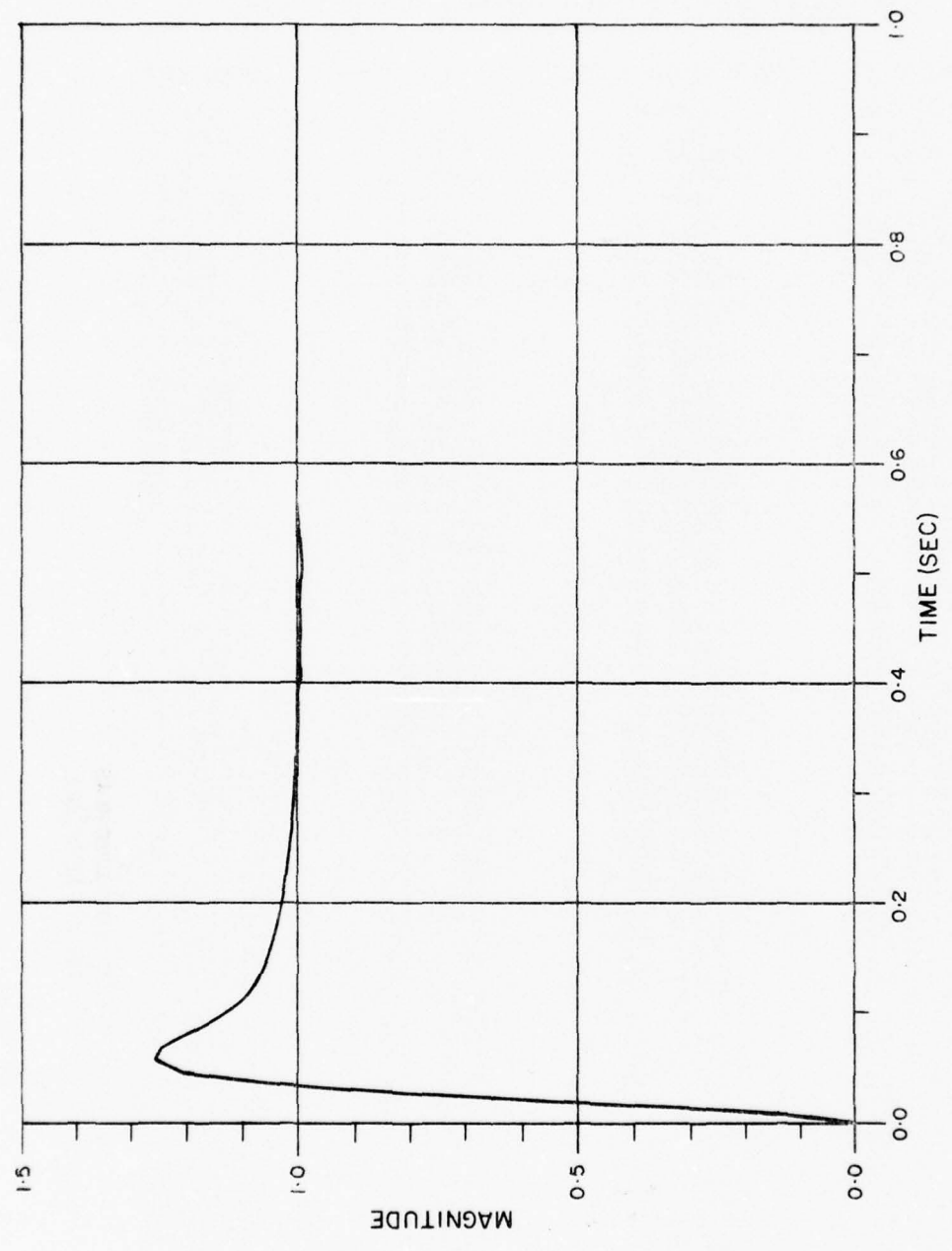

Figure D-2 Unit Step-Function Response (Design No. 1,  $T_s = 10$ )

TABLE D-3 UNIT STEP-FUNCTION RESPONSE (DESIGN #1,  $\tau_0 = 10$ )

TIME (SEC)	MAGNITUDE (ABS.)	REAL	IMAGINARY
.0000E 00	.0000E 00	.0000E 00	.0000E 00
.1000E -01	.1548E 00	.1548E 00	.0000E 00
.2000E -01	.5003E 00	.5003E 00	.0000E 00
.3000E -01	.8372E 00	.8372E 00	.0000E 00
.4000E -01	.1078E 01	.1078E 01	.0000E 00
.5000E -01	.1210E 01	.1210E 01	.0000E 00
.6000E -01	.1255E 01	.1255E 01	.0000E 00
.7000E -01	.1246E 01	.1246E 01	.0000E 00
.8000E -01	.1210E 01	.1210E 01	.0000E 00
.9000E -01	.1169E 01	.1169E 01	.0000E 00
.1000E 00	.1132E 01	.1132E 01	.0000E 00
.1100E 00	.1103E 01	.1103E 01	.0000E 00
.1200E 00	.1083E 01	.1083E 01	.0000E 00
.1300E 00	.1069E 01	.1069E 01	.0000E 00
.1400E 00	.1060E 01	.1060E 01	.0000E 00
.1500E 00	.1052E 01	.1052E 01	.0000E 00
.1600E 00	.1047E 01	.1047E 01	.0000E 00
.1700E 00	.1041E 01	.1041E 01	.0000E 00
.1800E 00	.1036E 01	.1036E 01	.0000E 00
.1900E 00	.1032E 01	.1032E 01	.0000E 00
.2000E 00	.1027E 01	.1027E 01	.0000E 00
.2100E 00	.1023E 01	.1023E 01	.0000E 00
.2200E 00	.1020E 01	.1020E 01	.0000E 00
.2300E 00	.1016E 01	.1016E 01	.0000E 00
.2400E 00	.1014E 01	.1014E 01	.0000E 00
.2500E 00	.1011E 01	.1011E 01	.0000E 00
.2600E 00	.1009E 01	.1009E 01	.0000E 00
.2700E 00	.1007E 01	.1007E 01	.0000E 00
.2800E 00	.1006E 01	.1006E 01	.0000E 00
.2900E 00	.1004E 01	.1004E 01	.0000E 00
.3000E 00	.1003E 01	.1003E 01	.0000E 00
.3100E 00	.1002E 01	.1002E 01	.0000E 00
.3200E 00	.1001E 01	.1001E 01	.0000E 00
.3300E 00	.1001E 01	.1001E 01	.0000E 00
.3400E 00	.9999E 00	.9999E 00	.0000E 00
.3500E 00	.9999E 00	.9999E 00	.0000E 00
.3600E 00	.9998E 00	.9998E 00	.0000E 00
.3700E 00	.9998E 00	.9998E 00	.0000E 00
.3800E 00	.9998E 00	.9998E 00	.0000E 00
.3900E 00	.9998E 00	.9998E 00	.0000E 00
.4000E 00	.9997E 00	.9997E 00	.0000E 00
.4100E 00	.9997E 00	.9997E 00	.0000E 00
.4200E 00	.9997E 00	.9997E 00	.0000E 00
.4300E 00	.9997E 00	.9997E 00	.0000E 00
.4400E 00	.9997E 00	.9997E 00	.0000E 00
.4500E 00	.9997E 00	.9997E 00	.0000E 00
.4600E 00	.9997E 00	.9997E 00	.0000E 00
.4700E 00	.9997E 00	.9997E 00	.0000E 00
.4800E 00	.9997E 00	.9997E 00	.0000E 00
.4900E 00	.9997E 00	.9997E 00	.0000E 00
.5000E 00	.9997E 00	.9997E 00	.0000E 00
.5100E 00	.9997E 00	.9997E 00	.0000E 00
.5200E 00	.9997E 00	.9997E 00	.0000E 00
.5300E 00	.9997E 00	.9997E 00	.0000E 00
.5400E 00	.9997E 00	.9997E 00	.0000E 00
.5500E 00	.9998E 00	.9998E 00	.0000E 00
.5600E 00	.9998E 00	.9998E 00	.0000E 00
.5700E 00	.9999E 00	.9999E 00	.0000E 00
.5800E 00	.9999E 00	.9999E 00	.0000E 00
.5900E 00	.9999E 00	.9999E 00	.0000E 00

THIS PAGE IS BEST QUALITY AVAILABLE FROM GPO PHOTODUPLICATION SERVICE

THIS PAGE IS BEST QUALITY AVAILABLE FROM GPO PHOTODUPLICATION SERVICE

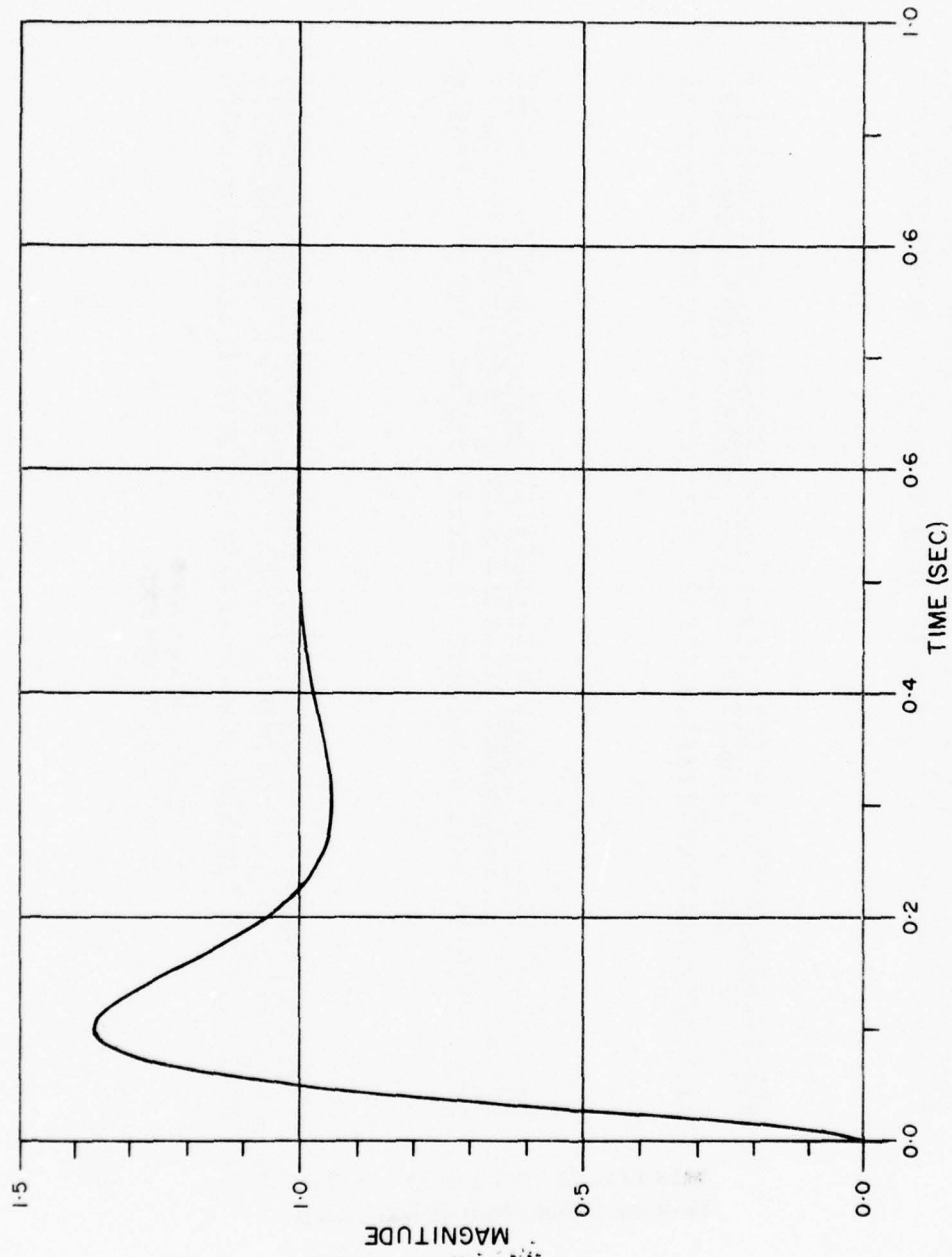

Figure D-3 Unit Step-Function Response (Design No. 2,  $T_s = 1$ )

TABLE D-4 UNIT STEP-FUNCTION RESPONSE (DESIGN #2,  $\tau_s = 1$ )

TIME (SEC)	MAGNITUDE (ABS.)	REAL	IMAGINARY
.0000E 00	.5632E -06	.5960E -07	-.5600E -06
.1000E -01	.9211E -01	.9211E -01	-.4682E -06
.2000E -01	.3126E 00	.3126E 00	-.3914E -06
.3000E -01	.5634E 00	.5634E 00	-.3272E -06
.4000E -01	.7958E 00	.7958E 00	-.2736E -06
.5000E -01	.9892E 00	.9892E 00	-.2287E -06
.6000E -01	.1138E 01	.1138E 01	-.1912E -06
.7000E -01	.1244E 01	.1244E 01	-.1599E -06
.8000E -01	.1313E 01	.1313E 01	-.1337E -06
.9000E -01	.1351E 01	.1351E 01	-.1117E -06
.1000E 00	.1364E 01	.1364E 01	-.9342E -07
.1100E 00	.1358E 01	.1358E 01	-.7810E -07
.1200E 00	.1339E 01	.1339E 01	-.6530E -07
.1300E 00	.1310E 01	.1310E 01	-.5459E -07
.1400E 00	.1275E 01	.1275E 01	-.4564E -07
.1500E 00	.1237E 01	.1237E 01	-.3816E -07
.1600E 00	.1198E 01	.1198E 01	-.3190E -07
.1700E 00	.1160E 01	.1160E 01	-.2667E -07
.1800E 00	.1124E 01	.1124E 01	-.2230E -07
.1900E 00	.1090E 01	.1090E 01	-.1864E -07
.2000E 00	.1060E 01	.1060E 01	-.1559E -07
.2100E 00	.1034E 01	.1034E 01	-.1303E -07
.2200E 00	.1011E 01	.1011E 01	-.1089E -07
.2300E 00	.9924E 00	.9924E 00	-.9107E -08
.2400E 00	.9768E 00	.9768E 00	-.7614E -08
.2500E 00	.9645E 00	.9645E 00	-.6366E -08
.2600E 00	.9550E 00	.9550E 00	-.5322E -08
.2700E 00	.9483E 00	.9483E 00	-.4449E -08
.2800E 00	.9438E 00	.9438E 00	-.3720E -08
.2900E 00	.9413E 00	.9413E 00	-.3110E -08
.3000E 00	.9405E 00	.9405E 00	-.2600E -08
.3100E 00	.9411E 00	.9411E 00	-.2174E -08
.3200E 00	.9428E 00	.9428E 00	-.1817E -08
.3300E 00	.9453E 00	.9453E 00	-.1519E -08
.3400E 00	.9485E 00	.9485E 00	-.1270E -08
.3500E 00	.9521E 00	.9521E 00	-.1062E -08
.3600E 00	.9561E 00	.9561E 00	-.8878E -09
.3700E 00	.9601E 00	.9601E 00	-.7433E -09
.3800E 00	.9642E 00	.9642E 00	-.6206E -09
.3900E 00	.9682E 00	.9682E 00	-.5188E -09
.4000E 00	.9721E 00	.9721E 00	-.4338E -09
.4100E 00	.9758E 00	.9758E 00	-.3626E -09
.4200E 00	.9793E 00	.9793E 00	-.3032E -09
.4300E 00	.9824E 00	.9824E 00	-.2535E -09
.4400E 00	.9854E 00	.9854E 00	-.2119E -09
.4500E 00	.9880E 00	.9880E 00	-.1772E -09
.4600E 00	.9903E 00	.9903E 00	-.1481E -09
.4700E 00	.9924E 00	.9924E 00	-.1238E -09
.4800E 00	.9942E 00	.9942E 00	-.1035E -09
.4900E 00	.9957E 00	.9957E 00	-.8655E -10
.5000E 00	.9970E 00	.9970E 00	-.7236E -10
.5100E 00	.9981E 00	.9981E 00	-.6050E -10
.5200E 00	.9991E 00	.9991E 00	-.5058E -10
.5300E 00	.9998E 00	.9998E 00	-.4229E -10
.5400E 00	.1000E 01	.1000E 01	-.3535E -10
.5500E 00	.1001E 01	.1001E 01	-.2956E -10
.5600E 00	.1001E 01	.1001E 01	-.2471E -10
.5700E 00	.1001E 01	.1001E 01	-.2066E -10
.5800E 00	.1002E 01	.1002E 01	-.1727E -10
.5900E 00	.1002E 01	.1002E 01	-.1444E -10
.6000E 00	.1002E 01	.1002E 01	

THIS PAGE IS BEST QUALITY AVAILABLE  
FROM COPY FURNISHED TO DRG

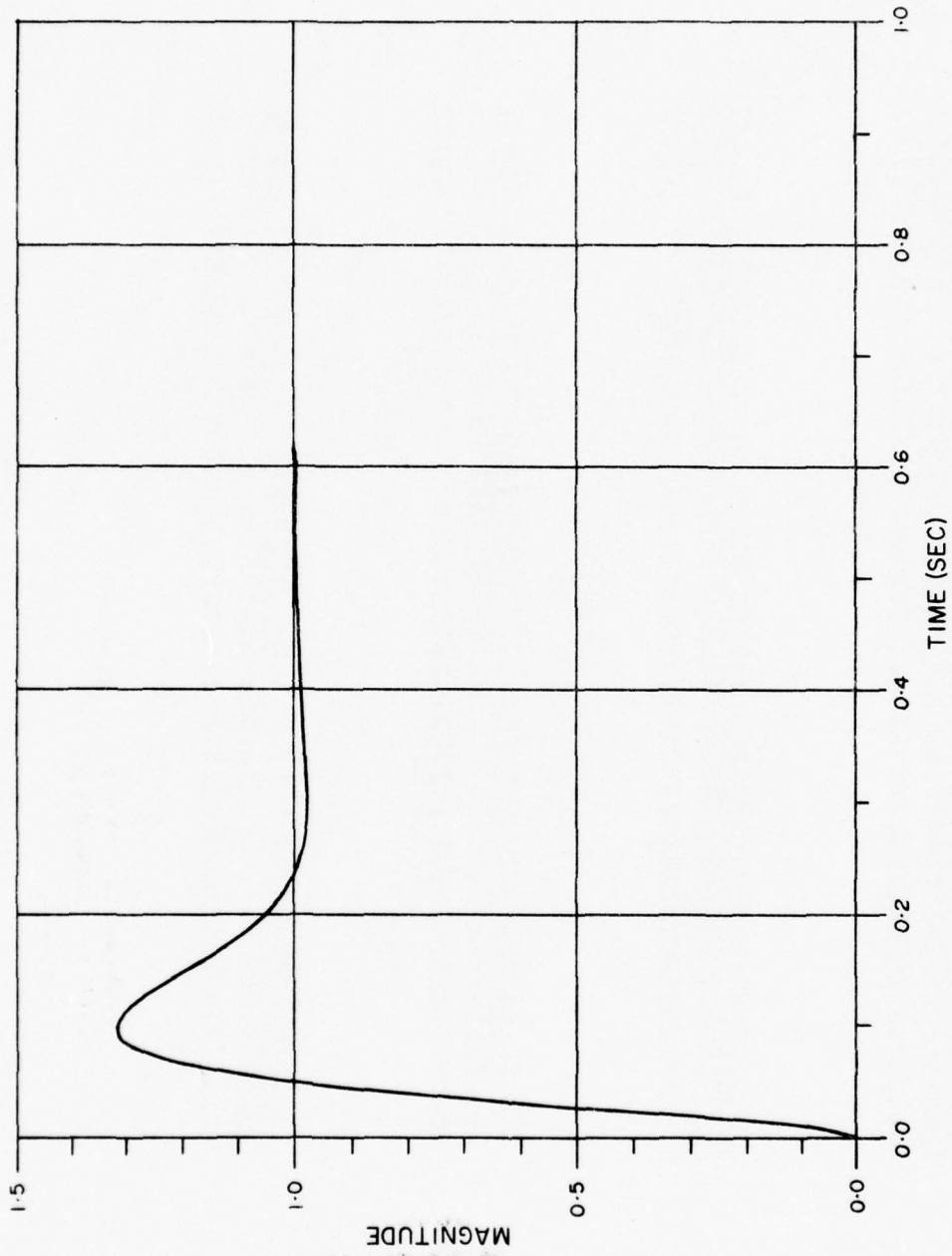

Figure D-4 Unit Step-Function Response (Design No. 2,  $T_s = 10$ )

TABLE D-5 UNIT STEP-FUNCTION RESPONSE (DESIGN #2,  $\tau = 10$ )

TIME (SEC)	MAGNITUDE (ABS.)	REAL	IMAGINARY
.000E 00	.3226E-05	.1490E-05	.2861E-05
.100E-01	.9198E-01	.9198E-01	.1907E-05
.200E-01	.3114E 00	.3114E 00	.1907E-05
.300E-01	.5596E 00	.5596E 00	.1907E-05
.400E-01	.7874E 00	.7874E 00	.1431E-05
.500E-01	.9748E 00	.9748E 00	.1132E-05
.600E-01	.1117E 01	.1117E 01	.9537E-06
.700E-01	.1215E 01	.1215E 01	.7153E-06
.800E-01	.1277E 01	.1277E 01	.5364E-06
.900E-01	.1309E 01	.1309E 01	.3576E-06
.100E 00	.1317E 01	.1317E 01	.2980E-06
.110E 00	.1308E 01	.1308E 01	.1192E-06
.120E 00	.1288E 01	.1288E 01	.5960E-07
.130E 00	.1260E 01	.1260E 01	.5960E-07
.140E 00	.1228E 01	.1228E 01	-.2236E-07
.150E 00	.1194E 01	.1194E 01	-.3353E-07
.160E 00	.1161E 01	.1161E 01	-.4843E-07
.170E 00	.1130E 01	.1130E 01	-.6333E-07
.180E 00	.1102E 01	.1102E 01	-.6796E-07
.190E 00	.1076E 01	.1076E 01	-.7079E-07
.200E 00	.1054E 01	.1054E 01	-.6333E-07
.210E 00	.1036E 01	.1036E 01	-.5588E-07
.220E 00	.1020E 01	.1020E 01	-.5588E-07
.230E 00	.1008E 01	.1008E 01	-.4843E-07
.240E 00	.9976E 00	.9976E 00	-.4098E-07
.250E 00	.9900E 00	.9900E 00	-.3726E-07
.260E 00	.9844E 00	.9844E 00	-.3353E-07
.270E 00	.9805E 00	.9805E 00	-.2236E-07
.280E 00	.9779E 00	.9779E 00	-.1863E-07
.290E 00	.9765E 00	.9765E 00	-.1491E-07
.300E 00	.9760E 00	.9760E 00	-.1118E-07
.310E 00	.9761E 00	.9761E 00	-.7455E-08
.320E 00	.9768E 00	.9768E 00	-.7455E-08
.330E 00	.9778E 00	.9778E 00	-.3730E-08
.340E 00	.9790E 00	.9790E 00	-.2798E-08
.350E 00	.9804E 00	.9804E 00	-.1401E-08
.360E 00	.9818E 00	.9818E 00	-.2373E-09
.370E 00	.9832E 00	.9832E 00	.2284E-09
.380E 00	.9846E 00	.9846E 00	.4612E-09
.390E 00	.9860E 00	.9860E 00	.9269E-09
.400E 00	.9872E 00	.9872E 00	.1393E-08
.410E 00	.9884E 00	.9884E 00	.1393E-08
.420E 00	.9895E 00	.9895E 00	.1160E-08
.430E 00	.9905E 00	.9905E 00	.1160E-08
.440E 00	.9913E 00	.9913E 00	.9269E-09
.450E 00	.9921E 00	.9921E 00	.9269E-09
.460E 00	.9928E 00	.9928E 00	.6941E-09
.470E 00	.9934E 00	.9934E 00	.9269E-09
.480E 00	.9940E 00	.9940E 00	.9269E-09
.490E 00	.9945E 00	.9945E 00	.4613E-09
.500E 00	.9949E 00	.9949E 00	.2285E-09
.510E 00	.9953E 00	.9953E 00	.3158E-09
.520E 00	.9957E 00	.9957E 00	.2576E-09
.530E 00	.9960E 00	.9960E 00	.1994E-09
.540E 00	.9963E 00	.9963E 00	.1412E-09
.550E 00	.9966E 00	.9966E 00	.9752E-10
.560E 00	.9968E 00	.9968E 00	.6842E-10
.570E 00	.9970E 00	.9970E 00	.3932E-10
.580E 00	.9972E 00	.9972E 00	.1022E-10
.590E 00	.9974E 00	.9974E 00	.1022E-10
.600E 00	.9976E 00	.9976E 00	

THIS PAGE IS BEST QUALITY AVAILABLE  
FROM COPY FURNISHED TO DRG

THIS PAGE IS BEST QUALITY AVAILABLE  
FROM COPY FURNISHED TO DRG

(2) SYSTEM RESPONSE WHEN SUBJECTED TO AN EXTERNAL DISTURBANCE ON THE MOTOR

Re-drawing the system block diagram with the disturbance as the input and the phase error as the output, we have

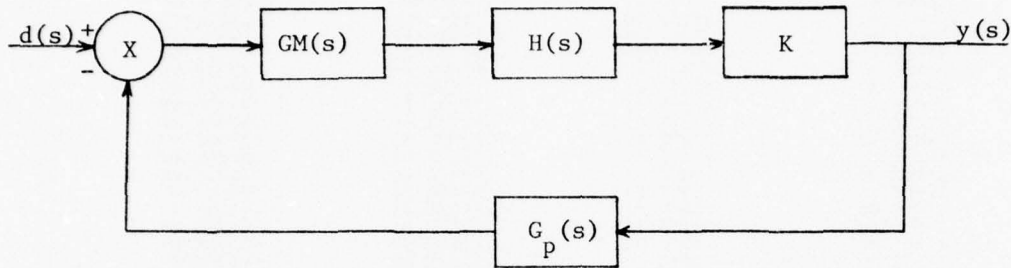

$$\frac{y(s)}{d(s)} = \frac{GM(s) H(s) K}{1 + G(s)} \quad \text{where } H(s) = 1$$

For a step input  $d(s) = \frac{1}{s}$

$$y(s) = \frac{GM(s) K}{1 + G(s)} \cdot \frac{1}{s} = \frac{KG_m \tau_5 s (1 + \tau_1 s) (1 + \tau_3 s) (1 + \tau_4 s)}{\tau_5 s^2 (1 + s \tau_m) (1 + \tau_1 s) (1 + \tau_3 s) (1 + \tau_4 s) + \frac{1}{KG_m [(1 + \tau_2 s)^2 \tau_5 s + (1 + \tau_3 s) (1 + \tau_4 s)]}}$$

$$y(t) = L^{-1}[y(s)]$$

A listing of the computer program is given in Table D-6. Two sets of graphs for  $y(t)$  are plotted in Figs. D-5 through D-8 and tabulated in Tables D-7 through D-10 for the two different phase compensation networks with different integrator gains. The input step applied is of magnitude  $\frac{1}{K}$  volts. Using eq. (3) given in Appendix C, the equivalent external torque applied to the capstan motor is given by

$$\begin{aligned} \Delta T &= BG_m V_o \\ &= BG_m \frac{1}{K} \\ &= \frac{60}{5.85 \times 2\pi} \times 9.106 \times \frac{1}{69.18} \text{ Oz-In} \\ &= 0.22 \text{ Oz-In} \end{aligned}$$

The actual digital phase detector has a higher gain than the one used in the digital computer analysis and there are 5000 slots on the actual tachometer used in the analog computer simulation. For the purpose of comparison, the phase error from the digital computer analysis must be converted to the number of slots slipped as would be registered by the digital phase detector.

(i) For design #1,  $\tau_5 = 1$  (Table D-7), the number of slots slipped at  $t = 0.15$  sec.

$$= 0.0235 \text{ volts} \times \frac{8 \text{ slots}}{2.5 \text{ volts}} \times \frac{\text{digital phase detector gain}}{\text{gain used in analysis}}$$

$$= 0.0235 \times \frac{8}{2.5} \times \frac{248.68}{69.18} \text{ slots}$$

$$= 0.27 \text{ slots}$$

$$\therefore \Delta T/\Delta \text{ slots} = \frac{0.22 \text{ Oz-In}}{0.27 \text{ slots}}$$

$$= 0.82 \text{ Oz-In/slot}$$

(ii) Similarly for design #1,  $\tau_5 = 10$  (Table D-8), the number of slots slipped at  $t = .17$  sec.

$$= 0.025 \times \frac{8}{2.5} \times 3.6 \text{ slots}$$

$$= 0.288 \text{ slots}$$

$$\therefore \Delta T/\Delta \text{ slots} = \frac{0.22}{0.288} \frac{\text{Oz-In}}{\text{slots}} = 0.76 \text{ Oz-In/slot}$$

The above results are tabulated in Table II on page 19 along with the results from the analog computer simulation.

TABLE D-6 COMPUTER PROGRAM OF THE EXTERNAL STEP DISTURBANCE RESPONSE

```

.500 C EXTERNAL STEP DISTURBANCE RESPONSE (DESIGN 81)
.600 C
.700 C
.800 C
1.000 COMPLEX R,S,R1,ANUM,A,TRES
2.000 DIMENSION Z(102), Y(102),XCOF(7),ROOTR(6),ROOTI(6),R(7),A(7)
3.000 Z(1)=101.0 ; Y(1)=101.0
4.000 M=6
5.000 AK=69.18
6.000 GM=9.106
7.000 T1=.001
8.000 T2=.1429
9.000 T3=.500
10.000 T4=.01
11.000 DO 50 J=1,2
12.000 TS=(J-1)*8. +J
13.000 TM=.500
14.000 XCOF(1)=AK*GM
15.000 XCOF(2)=AK*GM*(T3+T4+T5)
16.000 XCOF(3)=TS+AK*GM*(2.*T2*T5+T3*T4)
17.000 XCOF(4)=TS*(T1+T3+T4+TM+AK*GM*T2*T2)
18.000 XCOF(5)=T3*T4*T5+T1*TM*T5+(T3+T4)*(T1+TM)*T5
19.000 XCOF(6)=T1*T5*TM*(T3+T4) +T3*T4*T5*(T1+TM)
20.000 XCOF(7)=T1*T3*T4*T5*TM
21.000 CALL POLYROOT (XCOF,COF,M,ROOTR,ROOTI,IER)
22.000 DO 30 I=1,6
23.000 R(I+1)=CMPLX(ROOTR(I),ROOTI(I))
24.000 30 CONTINUE
25.000 R(1)=CMPLX(0.,0.)
26.000 DO 31 N=1,7
27.000 R1=R(N)
28.000 R(N)=R(1)
29.000 S=R1
30.000 ANUM=GM*T5*(1.+T1*T5)*(1.+T3*T5)*(1.+T4*T5)*S
31.000 A(N)=ANUM/((S-R(2))*(S-R(3))*(S-R(4))
32.000 1 *(S-R(5))*(S-R(6))*(S-R(7)))/XCOF(7)
33.000 R(N)=R1
34.000 31 CONTINUE
35.000 DO 32 K=1,101
36.000 T=(K-1)/20.
37.000 TRES=A(1)*CEXP(R(1)*T) +A(2)*CEXP(R(2)*T) +A(3)*CEXP(R(3)*T)
38.000 1 +A(4)*CEXP(R(4)*T) +A(5)*CEXP(R(5)*T) +A(6)*CEXP(R(6)*T)
39.000 2 +A(7)*CEXP(R(7)*T)
40.000 Z(K+1)=T
41.000 Y(K+1)=CABS(TRES)
42.000 WRITE(2,11) Z(K+1), Y(K+1) ,TRES
43.000 11 FORMAT(4E20.4)
44.000 32 CONTINUE
45.000 CALL INITT(240)
46.000 CALL BINITT
47.000 CALL CHECK(Z,Y)
48.000 CALL DISPLAY(Z,Y)
49.000 50 CONTINUE
50.000 CALL FINITT(0,700)
51.000 STOP
52.000 END
53.000 Y

```

THIS PAGE IS BEST QUALITY PAPER  
FROM COPY FURNISHED TO DDC

THIS PAGE IS BEST QUALITY PAPER  
FROM COPY FURNISHED TO DDC

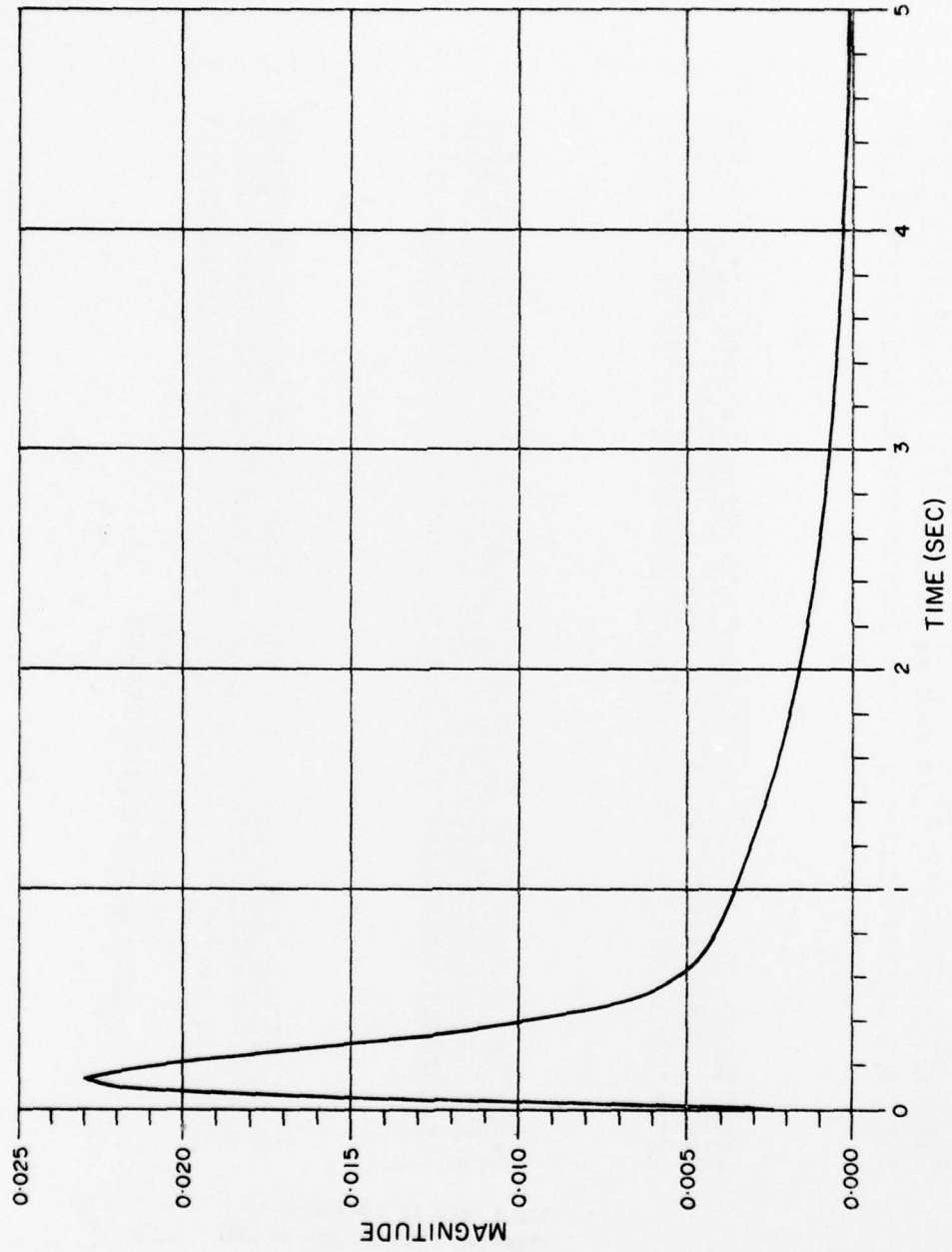

Figure D-5 External Step Disturbance Response (Design No. 1,  $T_s = 1$ )

TABLE D-7 EXTERNAL STEP DISTURBANCE RESPONSE (DESIGN #1,  $\tau_5 = 1$ )

TIME (SEC)	MAGNITUDE (ABS.)	REAL	IMAGINARY
.0000E 00	.5795E-07	.4698E-07	-.4098E-07
.5000E-01	.1293E-01	.1293E-01	-.2235E-07
.1000E 00	.2182E-01	.2182E-01	-.1863E-07
.1500E 00	.2306E-01	.2306E-01	-.3725E-08
.2000E 00	.2127E-01	.2127E-01	.0000E 00
.2500E 00	.1928E-01	.1820E-01	-.9313E-09
.3000E 00	.1511E-01	.1511E-01	.4657E-09
.3500E 00	.1229E-01	.1229E-01	.8877E-09
.4000E 00	.9993E-02	.9993E-02	.9313E-09
.4500E 00	.8235E-02	.8235E-02	.1164E-08
.5000E 00	.6946E-02	.6946E-02	.6985E-09
.5500E 00	.6028E-02	.6028E-02	.4657E-09
.6000E 00	.5386E-02	.5386E-02	.4657E-09
.6500E 00	.4937E-02	.4937E-02	.2328E-09
.7000E 00	.4618E-02	.4618E-02	.1601E-09
.7500E 00	.4381E-02	.4381E-02	.1019E-09
.8000E 00	.4194E-02	.4194E-02	.7276E-10
.8500E 00	.4037E-02	.4037E-02	.2910E-10
.9000E 00	.3896E-02	.3896E-02	.1455E-10
.9500E 00	.3763E-02	.3763E-02	-.9096E-12
.1000E 01	.3635E-02	.3635E-02	-.3638E-11
.1050E 01	.3509E-02	.3509E-02	-.5457E-11
.1100E 01	.3386E-02	.3386E-02	-.5457E-11
.1150E 01	.3265E-02	.3265E-02	-.3638E-11
.1200E 01	.3147E-02	.3147E-02	-.3638E-11
.1250E 01	.3032E-02	.3032E-02	-.2728E-11
.1300E 01	.2920E-02	.2920E-02	-.9096E-12
.1350E 01	.2811E-02	.2811E-02	-.1819E-11
.1400E 01	.2706E-02	.2706E-02	-.6821E-12
.1450E 01	.2605E-02	.2605E-02	-.3979E-12
.1500E 01	.2507E-02	.2507E-02	-.2274E-12
.1550E 01	.2413E-02	.2413E-02	-.5684E-13
.1600E 01	.2323E-02	.2323E-02	.0000E 00
.1650E 01	.2235E-02	.2235E-02	.1421E-13
.1700E 01	.2151E-02	.2151E-02	.2487E-13
.1750E 01	.2071E-02	.2071E-02	.3197E-13
.1800E 01	.1993E-02	.1993E-02	.2842E-13
.1850E 01	.1918E-02	.1918E-02	.2132E-13
.1900E 01	.1846E-02	.1846E-02	.1776E-13
.1950E 01	.1777E-02	.1777E-02	.1066E-13
.2000E 01	.1710E-02	.1710E-02	.7185E-14
.2050E 01	.1646E-02	.1646E-02	.3553E-14
.2100E 01	.1585E-02	.1585E-02	.2442E-14
.2150E 01	.1525E-02	.1525E-02	.1332E-14
.2200E 01	.1468E-02	.1468E-02	.6661E-15
.2250E 01	.1413E-02	.1413E-02	.2220E-15
.2300E 01	.1360E-02	.1360E-02	.0000E 00
.2350E 01	.1309E-02	.1309E-02	-.1388E-15
.2400E 01	.1260E-02	.1260E-02	-.1665E-15
.2450E 01	.1213E-02	.1213E-02	-.1527E-15
.2500E 01	.1167E-02	.1167E-02	-.1249E-15
.2550E 01	.1123E-02	.1123E-02	-.9714E-16
.2600E 01	.1081E-02	.1081E-02	-.6939E-16
.2650E 01	.1041E-02	.1041E-02	-.4163E-16
.2700E 01	.1002E-02	.1002E-02	-.2776E-16
.2750E 01	.9640E-03	.9640E-03	-.1388E-16
.2800E 01	.9279E-03	.9279E-03	-.1388E-16
.2850E 01	.8931E-03	.8931E-03	-.4337E-17
.2900E 01	.8596E-03	.8596E-03	-.1735E-17
.2950E 01	.8274E-03	.8274E-03	-.8674E-18
.3000E 01	.7963E-03	.7963E-03	

THIS PAGE IS BEST QUALITY PRINTOUT FROM COPY FURNISHED TO DDO

THIS PAGE IS BEST QUALITY PRINTOUT FROM COPY FURNISHED TO DDO

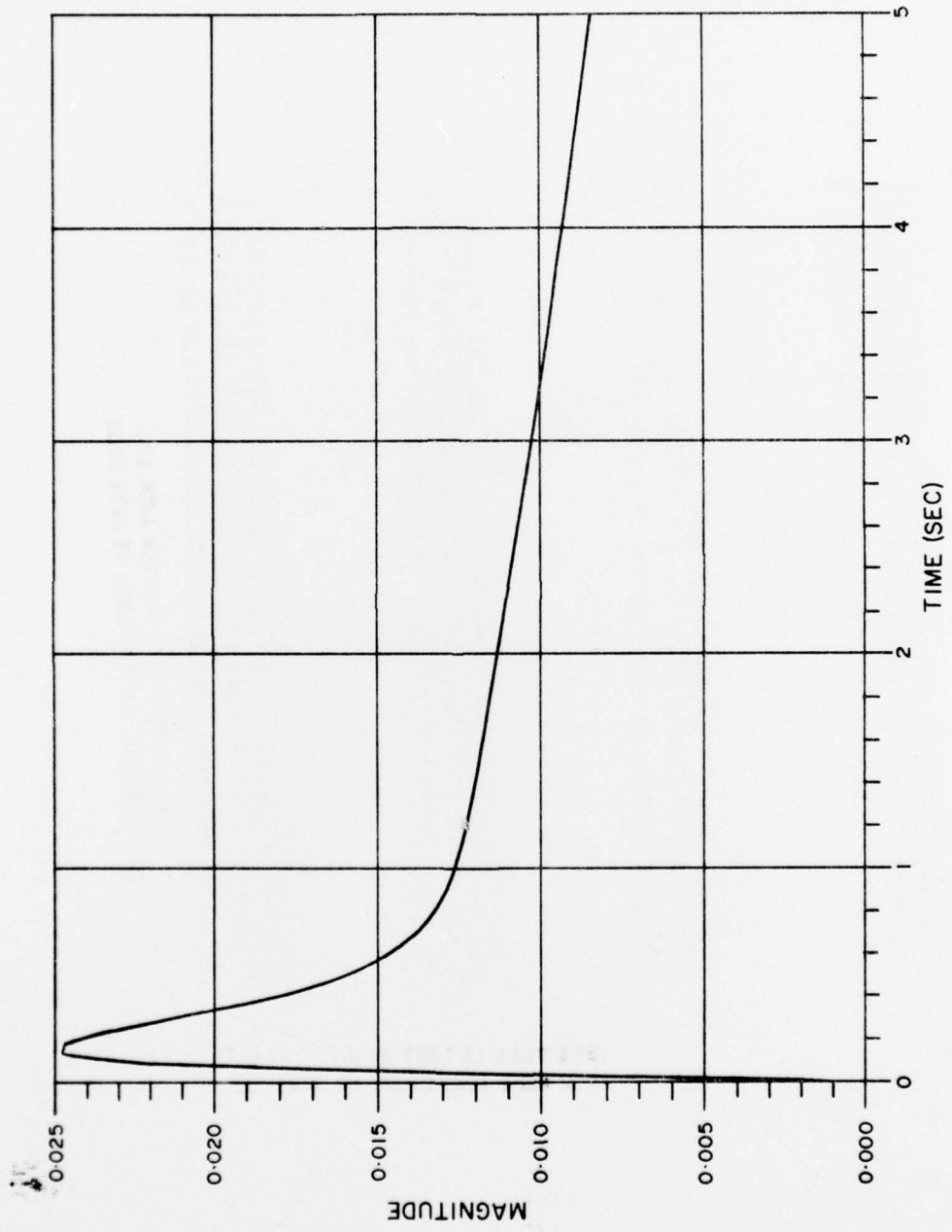

Figure D-6 External Step Disturbance Response (Design No. 1,  $T_s = 10$ )

TABLE D-8 EXTERNAL STEP DISTURBANCE RESPONSE (DESIGN #1,  $\tau_5 = 10$ )

TIME (SEC)	MAGNITUDE (ABS.)	REAL	IMAGINARY
.0000E 00	.2235E-07	-.2235E-07	.0000E 00
.5000E-01	.1296E-01	.1296E-01	.0000E 00
.1000E 00	.2234E-01	.2234E-01	.0000E 00
.1500E 00	.2482E-01	.2482E-01	.0000E 00
.2000E 00	.2469E-01	.2469E-01	.0000E 00
.2500E 00	.2339E-01	.2339E-01	.0000E 00
.3000E 00	.2171E-01	.2171E-01	.0000E 00
.3500E 00	.2003E-01	.2003E-01	.0000E 00
.4000E 00	.1854E-01	.1854E-01	.0000E 00
.4500E 00	.1728E-01	.1728E-01	.0000E 00
.5000E 00	.1625E-01	.1625E-01	.0000E 00
.5500E 00	.1542E-01	.1542E-01	.0000E 00
.6000E 00	.1477E-01	.1477E-01	.0000E 00
.6500E 00	.1426E-01	.1426E-01	.0000E 00
.7000E 00	.1385E-01	.1385E-01	.0000E 00
.7500E 00	.1353E-01	.1353E-01	.0000E 00
.8000E 00	.1328E-01	.1328E-01	.0000E 00
.8500E 00	.1308E-01	.1308E-01	.0000E 00
.9000E 00	.1291E-01	.1291E-01	.0000E 00
.9500E 00	.1277E-01	.1277E-01	.0000E 00
1.000E 01	.1265E-01	.1265E-01	.0000E 00
1.050E 01	.1255E-01	.1255E-01	.0000E 00
1.100E 01	.1246E-01	.1246E-01	.0000E 00
1.150E 01	.1237E-01	.1237E-01	.0000E 00
1.200E 01	.1230E-01	.1230E-01	.0000E 00
1.250E 01	.1222E-01	.1222E-01	.0000E 00
1.300E 01	.1216E-01	.1216E-01	.0000E 00
1.350E 01	.1209E-01	.1209E-01	.0000E 00
1.400E 01	.1203E-01	.1203E-01	.0000E 00
1.450E 01	.1196E-01	.1196E-01	.0000E 00
1.500E 01	.1190E-01	.1190E-01	.0000E 00
1.550E 01	.1184E-01	.1184E-01	.0000E 00
1.600E 01	.1178E-01	.1178E-01	.0000E 00
1.650E 01	.1173E-01	.1173E-01	.0000E 00
1.700E 01	.1167E-01	.1167E-01	.0000E 00
1.750E 01	.1161E-01	.1161E-01	.0000E 00
1.800E 01	.1155E-01	.1155E-01	.0000E 00
1.850E 01	.1150E-01	.1150E-01	.0000E 00
1.900E 01	.1144E-01	.1144E-01	.0000E 00
1.950E 01	.1139E-01	.1139E-01	.0000E 00
2.000E 01	.1133E-01	.1133E-01	.0000E 00
2.050E 01	.1127E-01	.1127E-01	.0000E 00
2.100E 01	.1122E-01	.1122E-01	.0000E 00
2.150E 01	.1116E-01	.1116E-01	.0000E 00
2.200E 01	.1111E-01	.1111E-01	.0000E 00
2.250E 01	.1106E-01	.1106E-01	.0000E 00
2.300E 01	.1100E-01	.1100E-01	.0000E 00
2.350E 01			

THIS PAGE IS BEST QUALITY PRACTICES  
FROM COPY FURNISHED TO DDC

THIS PAGE IS BEST QUALITY PRACTICES  
FROM COPY FURNISHED TO DDC

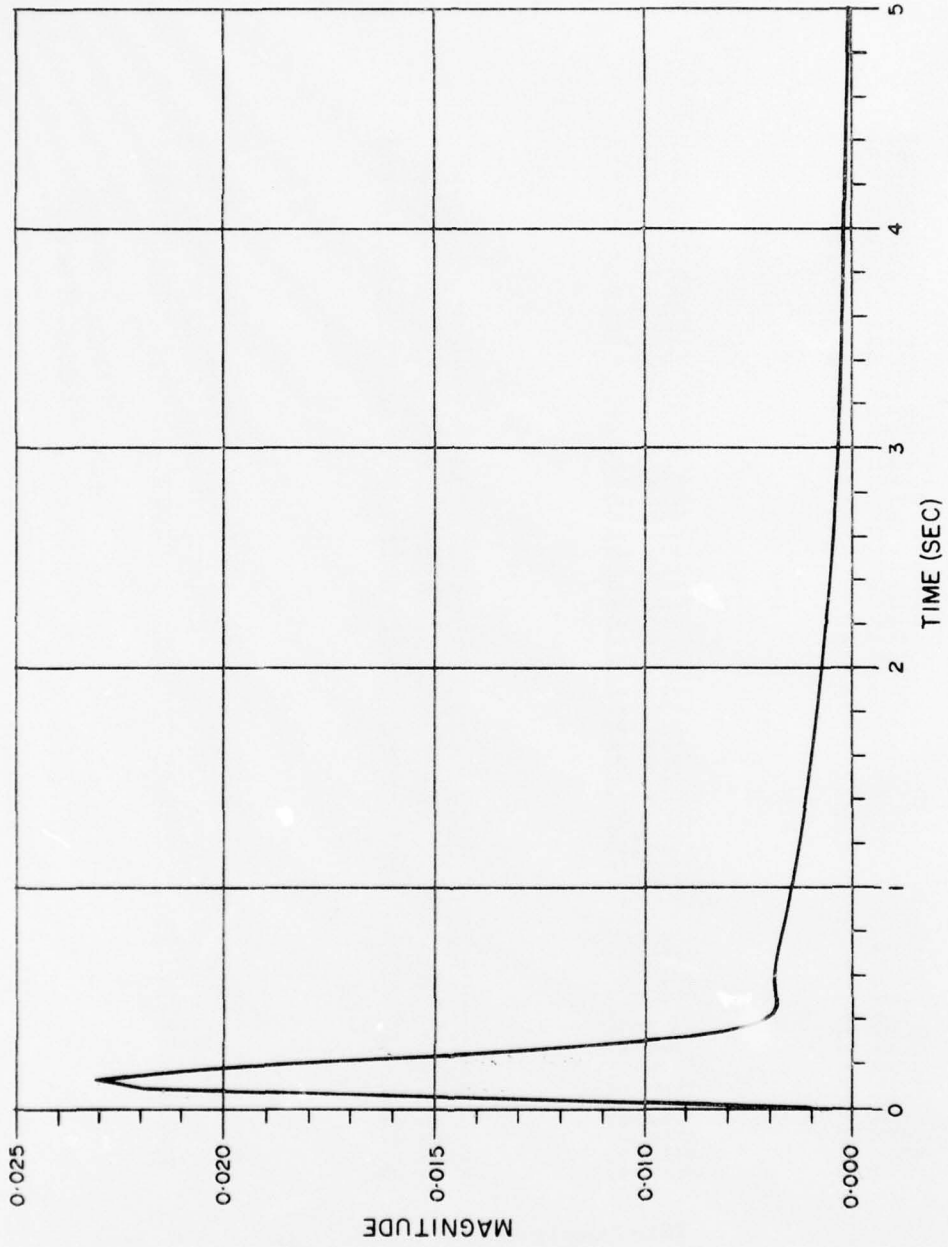

Figure D-7 External Step Disturbance Response (Design No. 2,  $\tau_s = 1$ )

TABLE D-9 EXTERNAL STEP DISTURBANCE RESPONSE (DESIGN #2,  $\tau_s = 1$ )

TIME (SEC)	MAGNITUDE (ABS.)	REAL	IMAGINARY
.0000E 00	.1233E-06	.1192E-06	.3136E-07
.5000E-01	.1586E-01	.1586E-01	.1433E-07
.1000E 00	.3378E-01	.3378E-01	.5854E-08
.1500E 00	.3622E-01	.3622E-01	.2391E-08
.2000E 00	.2852E-01	.2852E-01	.9766E-09
.2500E 00	.1871E-01	.1871E-01	.3980E-09
.3000E 00	.1109E-01	.1109E-01	.1620E-09
.3500E 00	.6593E-02	.6593E-02	.6654E-10
.4000E 00	.4523E-02	.4523E-02	.2718E-10
.4500E 00	.3844E-02	.3844E-02	.1110E-10
.5000E 00	.3761E-02	.3761E-02	.4534E-11
.5500E 00	.3829E-02	.3829E-02	.1852E-11
.6000E 00	.3864E-02	.3864E-02	.7564E-12
.6500E 00	.3829E-02	.3829E-02	.3090E-12
.7000E 00	.3739E-02	.3739E-02	.1262E-12
.7500E 00	.3623E-02	.3623E-02	.5154E-13
.8000E 00	.3499E-02	.3499E-02	.2105E-13
.8500E 00	.3379E-02	.3379E-02	.8598E-14
.9000E 00	.3264E-02	.3264E-02	.3512E-14
.9500E 00	.3156E-02	.3156E-02	.1434E-14
.1000E 01	.3053E-02	.3053E-02	.5850E-15
.1050E 01	.2954E-02	.2954E-02	.2393E-15
.1100E 01	.2858E-02	.2858E-02	.9774E-16
.1150E 01	.2765E-02	.2765E-02	.3992E-16
.1200E 01	.2675E-02	.2675E-02	.1631E-16
.1250E 01	.2589E-02	.2589E-02	.6660E-17
.1300E 01	.2505E-02	.2505E-02	.2720E-17
.1350E 01	.2423E-02	.2423E-02	.1111E-17
.1400E 01	.2344E-02	.2344E-02	.4538E-18
.1450E 01	.2268E-02	.2268E-02	.1854E-18
.1500E 01	.2195E-02	.2195E-02	.7571E-19
.1550E 01	.2123E-02	.2123E-02	.3092E-19
.1600E 01	.2054E-02	.2054E-02	.1263E-19
.1650E 01	.1988E-02	.1988E-02	.5159E-20
.1700E 01	.1923E-02	.1923E-02	.2107E-20
.1750E 01	.1860E-02	.1860E-02	.8606E-21
.1800E 01	.1800E-02	.1800E-02	.3515E-21
.1850E 01	.1742E-02	.1742E-02	.1436E-21
.1900E 01	.1685E-02	.1685E-02	.5864E-22
.1950E 01	.1630E-02	.1630E-02	.2395E-22
.2000E 01	.1577E-02	.1577E-02	.9783E-23
.2050E 01	.1526E-02	.1526E-02	.3996E-23
.2100E 01	.1476E-02	.1476E-02	.1632E-23
.2150E 01	.1428E-02	.1428E-02	.6666E-24
.2200E 01	.1382E-02	.1382E-02	.2723E-24
.2250E 01	.1337E-02	.1337E-02	.1112E-24
.2300E 01	.1294E-02	.1294E-02	.4542E-25
.2350E 01	.1252E-02	.1252E-02	.1855E-25
.2400E 01	.1211E-02	.1211E-02	.7577E-26
.2450E 01	.1172E-02	.1172E-02	.3095E-26
.2500E 01	.1134E-02	.1134E-02	.1264E-26
.2550E 01	.1097E-02	.1097E-02	.5163E-27
.2600E 01	.1061E-02	.1061E-02	.2109E-27
.2650E 01	.1027E-02	.1027E-02	.8614E-28
.2700E 01	.9933E-03	.9933E-03	.3518E-28
.2750E 01	.9611E-03	.9611E-03	.1437E-28
.2800E 01	.9298E-03	.9298E-03	.5869E-29
.2850E 01	.8976E-03	.8976E-03	.2397E-29
.2900E 01	.8704E-03	.8704E-03	.9791E-30
.2950E 01	.8431E-03	.8421E-03	.3999E-30
.3000E 01	.8148E-03	.8148E-03	

THIS PAGE IS BEST QUALITY PRINTABLE  
FROM COPY FURNISHED TO DDC

THIS PAGE IS BEST QUALITY PRINTABLE  
FROM COPY FURNISHED TO DDC

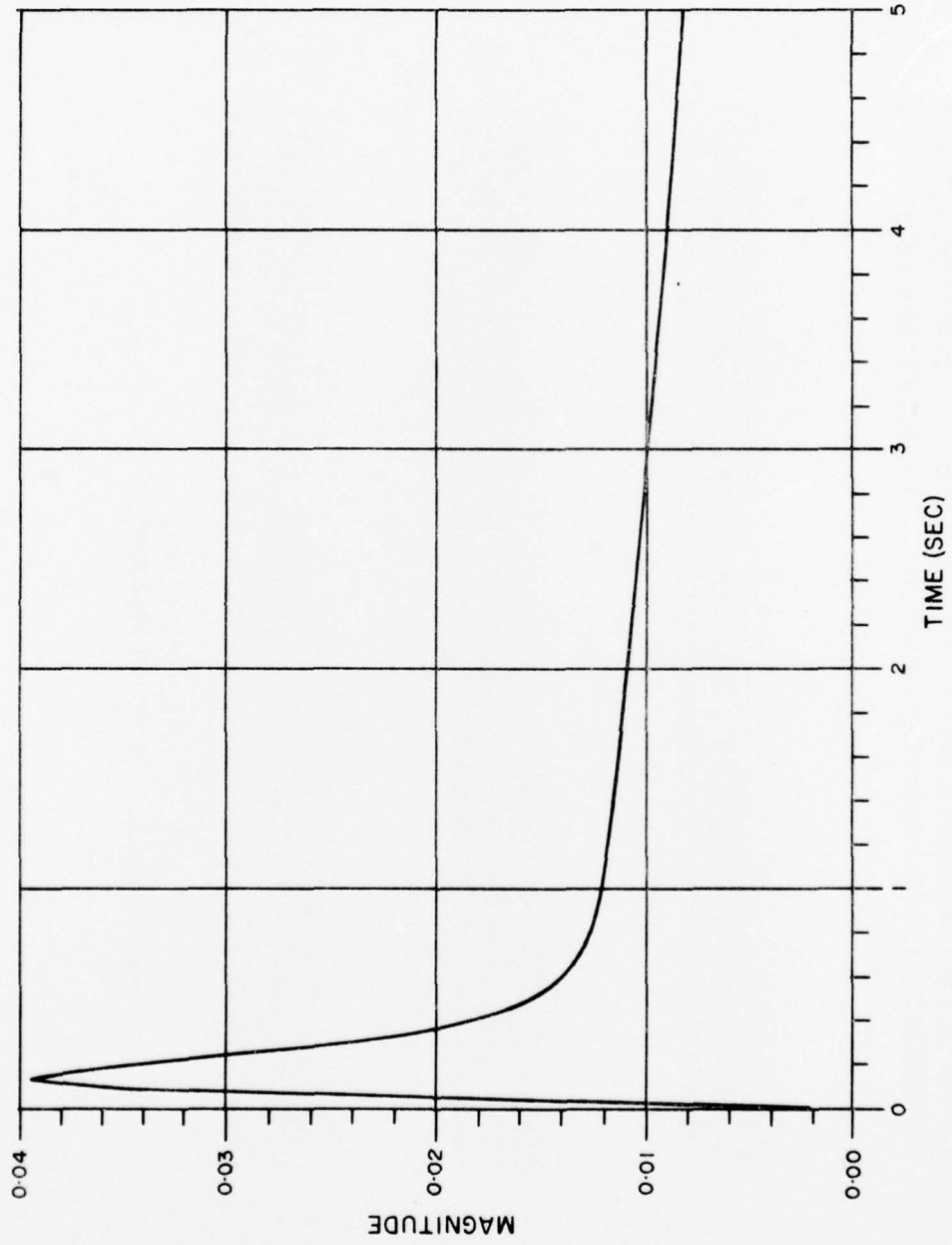

Figure D-8 External Step Disturbance Response (Design No. 2,  $\tau_s = 10$ )

TABLE D-10 EXTERNAL STEP DISTURBANCE RESPONSE (DESIGN #2,  $\tau_s = 10$ )

TIME (SEC)	MAGNITUDE (ABS.)	REAL	IMAGINARY
.0000E 00	.1718E-06	-.1676E-06	-.3771E-07
.5000E-01	.1589E-01	.1589E-01	.3271E-08
.1000E 00	.3456E-01	.3456E-01	.6999E-08
.1500E 00	.3953E-01	.3953E-01	.3276E-08
.2000E 00	.3581E-01	.3581E-01	.1182E-08
.2500E 00	.2987E-01	.2987E-01	-.2125E-09
.3000E 00	.2475E-01	.2475E-01	-.5888E-09
.3500E 00	.2106E-01	.2106E-01	-.5575E-09
.4000E 00	.1855E-01	.1855E-01	-.4972E-09
.4500E 00	.1683E-01	.1683E-01	-.4515E-09
.5000E 00	.1560E-01	.1560E-01	-.4330E-09
.5500E 00	.1471E-01	.1471E-01	-.4300E-09
.6000E 00	.1405E-01	.1405E-01	-.4298E-09
.6500E 00	.1356E-01	.1356E-01	-.4281E-09
.7000E 00	.1319E-01	.1319E-01	-.4266E-09
.7500E 00	.1291E-01	.1291E-01	-.4246E-09
.8000E 00	.1269E-01	.1269E-01	-.4226E-09
.8500E 00	.1251E-01	.1251E-01	-.4205E-09
.9000E 00	.1237E-01	.1237E-01	-.4185E-09
.9500E 00	.1225E-01	.1225E-01	-.4165E-09
.1000E 01	.1215E-01	.1215E-01	-.4145E-09
.1050E 01	.1206E-01	.1206E-01	-.4125E-09
.1100E 01	.1198E-01	.1198E-01	-.4105E-09
.1150E 01	.1191E-01	.1191E-01	-.4086E-09
.1200E 01	.1184E-01	.1184E-01	-.4066E-09
.1250E 01	.1178E-01	.1178E-01	-.4047E-09
.1300E 01	.1172E-01	.1172E-01	-.4027E-09
.1350E 01	.1166E-01	.1166E-01	-.4008E-09
.1400E 01	.1160E-01	.1160E-01	-.3989E-09
.1450E 01	.1154E-01	.1154E-01	-.3970E-09
.1500E 01	.1148E-01	.1148E-01	-.3951E-09
.1550E 01	.1143E-01	.1143E-01	-.3932E-09
.1600E 01	.1137E-01	.1137E-01	-.3912E-09
.1650E 01	.1132E-01	.1132E-01	-.3895E-09
.1700E 01	.1126E-01	.1126E-01	-.3876E-09
.1750E 01	.1121E-01	.1121E-01	-.3857E-09
.1800E 01	.1116E-01	.1116E-01	-.3839E-09
.1850E 01	.1110E-01	.1110E-01	-.3821E-09
.1900E 01	.1105E-01	.1105E-01	-.3802E-09
.1950E 01	.1100E-01	.1100E-01	-.3784E-09
.2000E 01	.1094E-01	.1094E-01	-.3766E-09
.2050E 01	.1089E-01	.1089E-01	-.3748E-09
.2100E 01	.1084E-01	.1084E-01	-.3730E-09
.2150E 01	.1079E-01	.1079E-01	-.3712E-09
.2200E 01	.1074E-01	.1074E-01	-.3695E-09
.2250E 01	.1068E-01	.1068E-01	-.3677E-09
.2300E 01	.1063E-01	.1063E-01	-.3659E-09
.2350E 01	.1058E-01	.1058E-01	-.3642E-09
.2400E 01	.1053E-01	.1053E-01	-.3625E-09
.2450E 01	.1048E-01	.1048E-01	-.3607E-09
.2500E 01	.1043E-01	.1043E-01	-.3590E-09
.2550E 01	.1038E-01	.1038E-01	-.3573E-09
.2600E 01	.1033E-01	.1033E-01	-.3556E-09
.2650E 01	.1028E-01	.1028E-01	-.3539E-09
.2700E 01	.1023E-01	.1023E-01	-.3522E-09
.2750E 01	.1018E-01	.1018E-01	-.3505E-09
.2800E 01	.1014E-01	.1014E-01	-.3488E-09
.2850E 01	.1009E-01	.1009E-01	-.3472E-09
.2900E 01	.1004E-01	.1004E-01	-.3455E-09
.2950E 01	.9991E-02	.9991E-02	-.3439E-09
.3000E 01	.9943E-02	.9943E-02	-.3422E-09
.3050E 01	.9895E-02	.9895E-02	-.3406E-09
.3100E 01			

THIS PAGE IS BEST QUALITY PRACTICABLE  
FROM COPY FURNISHED TO DDC

THIS PAGE IS BEST QUALITY PRACTICABLE  
FROM COPY FURNISHED TO DDC

APPENDIX E

THE EFFECT OF OTHER MOTORS ON THE CAPSTAN MOTOR SERVO SYSTEM

THE EFFECT OF OTHER MOTORS ON THE CAPSTAN MOTOR SERVO SYSTEM

With the servo system connected as shown in the diagram below, the effect of other motors on the capstan servo will be analysed as follows:

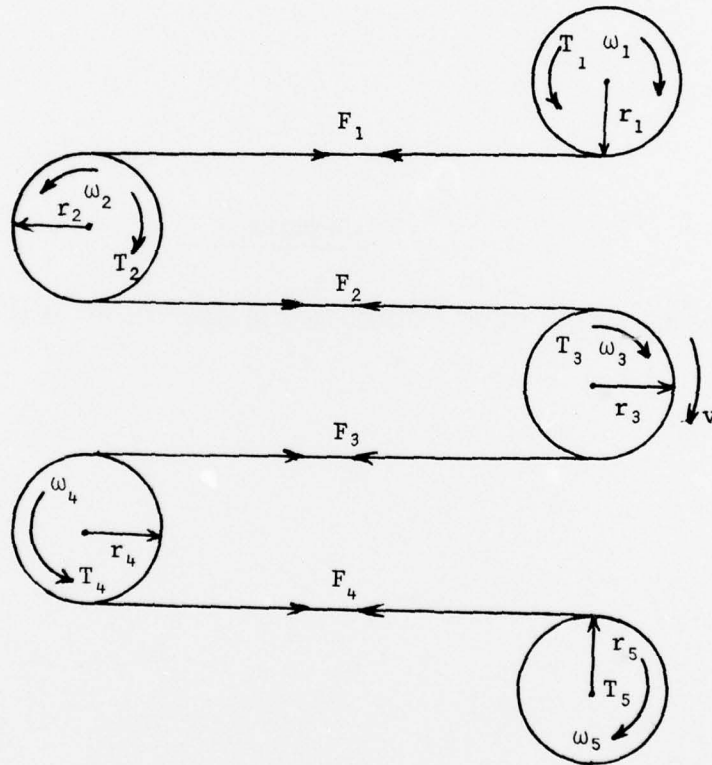

The system dynamic equations are:

$$F_1 r_1 - T_1 = f_1 \omega_1 + J_1 \dot{\omega}_1 \quad (1)$$

$$(F_2 - F_1) r_2 - T_2 = f_2 \omega_2 + J_2 \dot{\omega}_2 \quad (2)$$

$$T_3 + (F_3 - F_2) r_3 = f_3 \omega_3 + J_3 \dot{\omega}_3 \quad (3)$$

$$(F_4 - F_3) r_4 + T_4 = f_4 \omega_4 + J_4 \dot{\omega}_4 \quad (4)$$

$$T_5 - F_4 r_5 = f_5 \omega_5 + J_5 \dot{\omega}_5 \quad (5)$$

The link equations are given as:

$$\omega_1 r_1 = \omega_2 r_2 = \omega_3 r_3 = \omega_4 r_4 = \omega_5 r_5 \quad (6)$$

With the system running at steady-state, all the forces acting on the system are balanced. Now a disturbance  $\Delta T_3$  is applied to the capstan motor and the effect on the system is to be analysed. Using the same symbols as above for the variations from the steady-state condition we have the following set of equations:

$$\Delta F_1 r_1 = f_1 \Delta \omega_1 + J_1 \Delta \dot{\omega}_1$$

$$(\Delta F_2 - \Delta F_1) r_2 = f_2 \Delta \omega_2 + J_2 \Delta \dot{\omega}_2$$

$$\Delta T_3 + (\Delta F_3 - \Delta F_2) r_3 = f_3 \Delta \omega_3 + J_3 \Delta \dot{\omega}_3$$

$$(\Delta F_4 - \Delta F_3) r_4 = f_4 \Delta \omega_4 + J_4 \Delta \dot{\omega}_4$$

$$-\Delta F_4 r_5 = f_5 \Delta \omega_5 + J_5 \Delta \dot{\omega}_5$$

$$\Delta \omega_1 r_1 = \Delta \omega_2 r_2 = \Delta \omega_3 r_3 = \Delta \omega_4 r_4 = \Delta \omega_5 r_5$$

Solving the above equations for  $\Delta \omega_3$ , we have

$$\Delta \omega_3 = \frac{\Delta T_3}{s C_1 + C_2}$$

where

$$C_1 = J_3 + J_1 \frac{r_3^2}{r_1^2} + J_2 \frac{r_3^2}{r_2^2} + J_4 \frac{r_3^2}{r_4^2} + J_5 \frac{r_3^2}{r_5^2}$$

$$C_2 = f_3 + f_1 \frac{r_3^2}{r_1^2} + f_2 \frac{r_3^2}{r_2^2} + f_4 \frac{r_3^2}{r_4^2} + f_5 \frac{r_3^2}{r_5^2}$$

or

$$\Delta \omega_3 = \frac{\Delta T_3 / C_2}{1 + s C_1 / C_2}$$

For a step  $\Delta T_3 = T_3/s$

$$\Delta\omega(t) = \Delta T_3/C_2 (1 - e^{-C_2/C_1 t})$$

## UNCLASSIFIED

Security Classification

DOCUMENT CONTROL DATA - R & D		
(Security classification of title, body of abstract and indexing annotation must be entered when the overall document is classified)		
1. ORIGINATING ACTIVITY Defence Research Establishment Ottawa National Defence Headquarters Ottawa, Ontario, Canada, K1A 0Z4	2a. DOCUMENT SECURITY CLASSIFICATION <b>UNCLASSIFIED</b>	2b. GROUP
3. DOCUMENT TITLE Design and Development of the Servo System for the Back-up Optical Recorder of the SEASAT A Project (U)		
4. DESCRIPTIVE NOTES (Type of report and inclusive dates) <b>Technical Note</b>		
5. AUTHOR(S) (Last name, first name, middle initial) <b>LEE, J.P.</b>		
6. DOCUMENT DATE <b>May 1979</b>	7a. TOTAL NO. OF PAGES <b>79</b>	7b. NO. OF REFS
8a. PROJECT OR GRANT NO. <b>33D00</b>	9a. ORIGINATOR'S DOCUMENT NUMBER(S) <b>DREO TN 79-9</b> ✓	
8b. CONTRACT NO.	9b. OTHER DOCUMENT NO.(S) (Any other numbers that may be assigned this document)	
10. DISTRIBUTION STATEMENT <b>Qualified Requesters May Obtain Copies of this Document from their Defence Documentation Center</b>		
11. SUPPLEMENTARY NOTES	12. SPONSORING ACTIVITY <b>DREO Defence Electronics Division</b>	
13. ABSTRACT <b>UNCLASSIFIED</b>  This report is written on the design, analysis, simulation and final testing of the phaselocked servo system for the back-up optical film recorder. The design procedure used is the Bode method and a position resolution equivalent to $2\pi/(5000 \times 16)$ radians is desired. The analysis is carried out by both analog computer simulation and digital computer calculations. Separate control circuits are used for the reel servos and the tension motors are supplied with constant current sources. Finally the complete system was built and tested, giving a performance which met specification.  (ji)		

## KEY WORDS

Servo  
Optical Recorder  
Data Recorder

## INSTRUCTIONS

1. **ORIGINATING ACTIVITY:** Enter the name and address of the organization issuing the document.
- 2a. **DOCUMENT SECURITY CLASSIFICATION:** Enter the overall security classification of the document including special warning terms whenever applicable.
- 2b. **GROUP:** Enter security reclassification group number. The three groups are defined in Appendix 'M' of the DRB Security Regulations.
3. **DOCUMENT TITLE:** Enter the complete document title in all capital letters. Titles in all cases should be unclassified. If a sufficiently descriptive title cannot be selected without classification, show title classification with the usual one-capital-letter abbreviation in parentheses immediately following the title.
4. **DESCRIPTIVE NOTES:** Enter the category of document, e.g. technical report, technical note or technical letter. If appropriate, enter the type of document, e.g. interim, progress, summary, annual or final. Give the inclusive dates when a specific reporting period is covered.
5. **AUTHOR(S):** Enter the name(s) of author(s) as shown on or in the document. Enter last name, first name, middle initial. If military, show rank. The name of the principal author is an absolute minimum requirement.
6. **DOCUMENT DATE:** Enter the date (month, year) of Establishment approval for publication of the document.
- 7a. **TOTAL NUMBER OF PAGES:** The total page count should follow normal pagination procedures, i.e., enter the number of pages containing information.
- 7b. **NUMBER OF REFERENCES:** Enter the total number of references cited in the document.
- 8a. **PROJECT OR GRANT NUMBER:** If appropriate, enter the applicable research and development project or grant number under which the document was written.
- 8b. **CONTRACT NUMBER:** If appropriate, enter the applicable number under which the document was written.
- 9a. **ORIGINATOR'S DOCUMENT NUMBER(S):** Enter the official document number by which the document will be identified and controlled by the originating activity. This number must be unique to this document.
- 9b. **OTHER DOCUMENT NUMBER(S):** If the document has been assigned any other document numbers (either by the originator or by the sponsor), also enter this number(s).
10. **DISTRIBUTION STATEMENT:** Enter any limitations on further dissemination of the document, other than those imposed by security classification, using standard statements such as:
  - (1) "Qualified requesters may obtain copies of this document from their defence documentation center."
  - (2) "Announcement and dissemination of this document is not authorized without prior approval from originating activity."
11. **SUPPLEMENTARY NOTES:** Use for additional explanatory notes.
12. **SPONSORING ACTIVITY:** Enter the name of the departmental project office or laboratory sponsoring the research and development. Include address.
13. **ABSTRACT:** Enter an abstract giving a brief and factual summary of the document, even though it may also appear elsewhere in the body of the document itself. It is highly desirable that the abstract of classified documents be unclassified. Each paragraph of the abstract shall end with an indication of the security classification of the information in the paragraph (unless the document itself is unclassified) represented as (TS), (S), (C), (R), or (U).  
  
The length of the abstract should be limited to 20 single-spaced standard typewritten lines; 7½ inches long.
14. **KEY WORDS:** Key words are technically meaningful terms or short phrases that characterize a document and could be helpful in cataloging the document. Key words should be selected so that no security classification is required. Identifiers, such as equipment model designation, trade name, military project code name, geographic location, may be used as key words but will be followed by an indication of technical context.