

AD-A078 554

JOINT TASK FORCE SEVEN WASHINGTON DC
OPERATION SANDSTONE, NUCLEAR EXPLOSIONS. SCIENTIFIC DIRECTOR'S --ETC(U)
1948

F/G 6/18

UNCLASSIFIED

OF 2

AD
AO 7855A

NL



IFIED

1 OF

22

AD

AO 78554

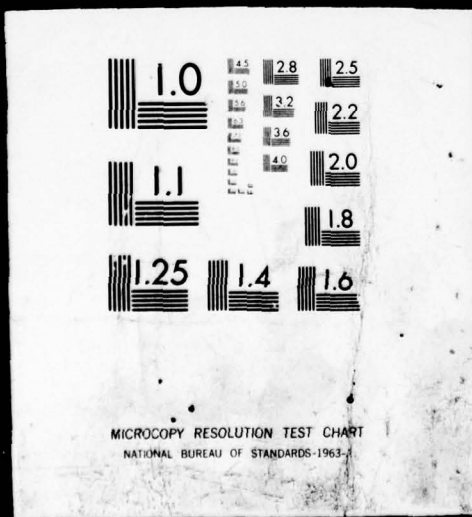

PHOTOGRAPH THIS SHEET

ADA 078554

DTIC ACCESSION NUMBER



LEVEL



INVENTORY

Sandstone Report 31

Scientific Director's Report of Atomic Weapon Tests
Annex 10 Radiological Safety Instruments

DOCUMENT IDENTIFICATION

DISTRIBUTION STATEMENT A

Approved for public release;
Distribution Unlimited

DISTRIBUTION STATEMENT

ACCESSION FOR	
NTIS	GRA&I <input checked="" type="checkbox"/>
DTIC	TAB <input type="checkbox"/>
UNANNOUNCED	<input type="checkbox"/>
JUSTIFICATION	
Per Hqs. on file	
BY	
DISTRIBUTION /	
AVAILABILITY CODES	
DIST	AVAIL AND/OR SPECIAL
A	

DISTRIBUTION STAMP

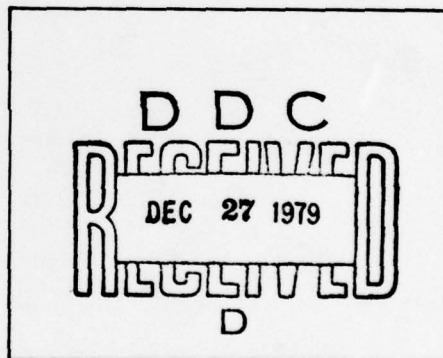

DATE ACCESSIONED

79 2 20 578

DATE RECEIVED IN DTIC

PHOTOGRAPH THIS SHEET AND RETURN TO DTIC-DDA-2

UNCLASSIFIED

LIBRARY COPY No. 7

5

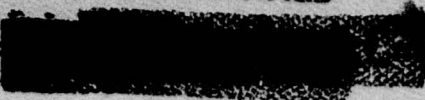

LIBRARY TECHNICAL FILE

CLASSIFIED

12-0

WTA
TECHNICAL LIBRARY
of the
DEFENSE ATOMIC
SUPPORT AGENCY

Subject

ADA 078554

OPERATION SANDSTONE NUCLEAR EXPLOSIONS

1948

1247 WOE
DNA
DFOJ

Reviewed by WOE
8/8/77



Classification (Cancelled) (Changed to) UNCLASSIFIED
By Authority of Chief AFSAW 116157
By R. Taurin Date Oct 9 1958

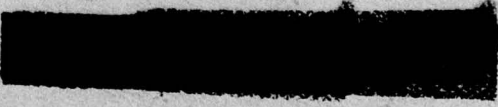

Statement A
Approved for public release
Distribution unlimited

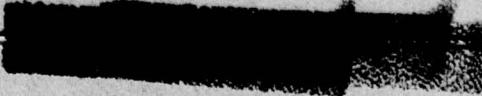

UNCLASSIFIED

✓

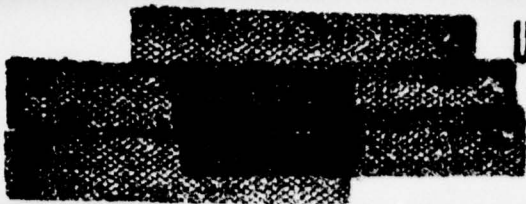

UNCLASSIFIED

THIS DOCUMENT CONSISTS OF 145 PAGE(S)
NO. 7 OF 20 COPIES, SERIES A

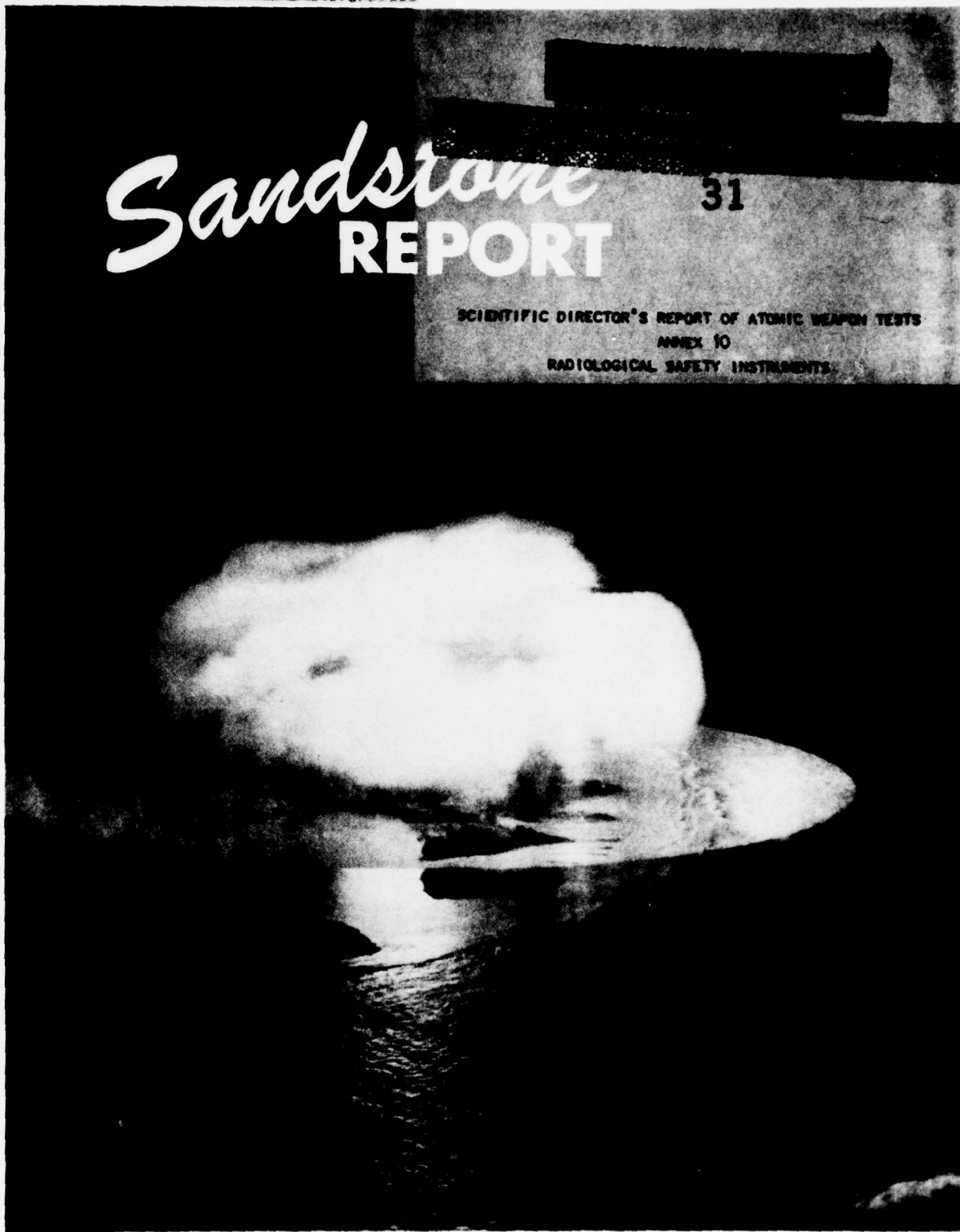

Sandstone REPORT

31

SCIENTIFIC DIRECTOR'S REPORT OF ATOMIC WEAPON TESTS
ANNEX 10
RADIOLOGICAL SAFETY INSTRUMENTS

UNCLASSIFIED



[REDACTED]

UNCLASSIFIED

Task Group 7.6

Project Report

LIBRARY TECHNICAL FILE

CLASSIFIED

12-0

Subject

EVALUATION OF RADIOLOGICAL SURVEY INSTRUMENTS

Used for Health Protection

during

OPERATION SANDSTONE

by

CDR Howard L. Andrews, USPHS

Commander, Task Unit 7.6.4

and

LCDR Donald C. Campbell, USN

1 April 1949

[REDACTED]

Project 7.2-17/22-25

UNCLASSIFIED

[REDACTED]

[REDACTED]

UNCLASSIFIED

~~CONFIDENTIAL~~

~~RESTRICTED~~

TABLE OF CONTENTS

~~RESTRICTED DATA~~

Page

ATOMIC ENERGY ACT - 1946
 SPECIFIC RESTRICTED DATA CLEARANCE NOT REQUIRED
 USE MILITARY CLASSIFICATION SAFEGUARDS

I	ABSTRACT	1
II	PROCUREMENT OF INSTRUMENTS	1
III	FACILITIES AVAILABLE	3
IV	INSTRUMENTS AVAILABLE.	4
	A GEIGER-MUELLER SURVEY INSTRUMENTS.	7
	B IONIZATION CHAMBER SURVEY INSTRUMENTS.	7
	C INTEGRATING DOSE METER	10
	D OTHER INSTRUMENTS.	13
V	RESULTS OF FIELD EXPERIENCE WITH RADIOLOGICAL SURVEY INSTRUMENTS .	13
	A USE AND REPAIR RECORDS	13
	B DESIGN DEFECTS	21
VI	TESTS ON INSTRUMENTS AND RESULTS	24
	A USEFUL OPERATING LIFE.	31
	B LINEARITY OF RESPONSE.	36
	C DIRECTIONAL RESPONSE	41
	D ALTITUDE EFFECTS	52
	E SHOCK RESISTANCE	54
	F IMMERSION.	54
	G TILT FROM VERTICAL	55
	H METERING TIME CONSTANT	55
	I MICROPHONICS	56
	J MISCELLANEOUS TESTS ON SURVEY INSTRUMENTS.	56
	K TESTS ON POCKET DOSIMETERS	56
VII	CONCLUSIONS AND RECOMMENDATIONS.	59
VIII	REFERENCES	60
	APPENDIX A - FINAL REPORT OF THE SUBCOMMITTEE ON RADSAFE SURVEY	
	INSTRUMENTS DATED 4 OCTOBER 1947.	61
	APPENDIX B - PHOTOGRAPHIC FILM LABORATORY.	70

~~RESTRICTED~~

UNCLASSIFIED

~~CONFIDENTIAL~~

~~RESTRICTED~~

UNCLASSIFIED

EVALUATION OF RADIOLOGICAL SURVEY INSTRUMENTS USED FOR HEALTH PROTECTION
DURING OPERATION SANDSTONE

~~RESTRICTED DATA~~

ATOMIC ENERGY ACT - 1946

RESTRICTED DATA CLEARANCE NOT REQUIRED
AND MILITARY CLASSIFICATION SAFEGUARDS

I ABSTRACT

Task Group 7.6, with assigned responsibilities for radiological health protection during Operation Sandstone, conducted certain tests and made observations on field performance of a number of miscellaneous instruments including Geiger-Mueller survey instruments, ionization chamber survey instruments, and integrating dosimeters.

This report contains observations on the numbers and types of instruments required for operations of a similar nature to Operation Sandstone. Certain design defects are noted in the instruments used, and some corrective recommendations are made.

In general, the performance of the instruments used during the operation was good. Serious leakage problems were encountered with pocket dosimeters. Some troubles were encountered in the use of instruments in aircraft.

Information is given in Appendix B on the processing of film badges used for health protection.

II PROCUREMENT OF INSTRUMENTS

Instruments capable of detecting and measuring ionizing radiation will have great importance in future national defense, and since health protection required certain instruments during the Atomic Weapon tests of Operation Sandstone, it was considered desirable to utilize the experience of the operation to obtain information on field performance of various instruments. The radiological safety organization,

~~RESTRICTED~~

UNCLASSIFIED

~~RESTRICTED~~ UNCLASSIFIED

Task Group 7.6, was the logical organization to carry out the studies, and on 18 September 1947 Colonel James P. Cooney (MC) USA appointed a group consisting of CDR Howard L. Andrews, USPHS, CDR D. C. Campbell, USN, and Dr. Ralph E. Lapp JEDS, to study the availability of suitable survey instruments and to make certain recommendations regarding procurement.

The group was warned by Colonel Cooney that the instrument testing program, although highly desirable and important, must not jeopardize the main mission of Task Group 7.6 which was the protection of the personnel of the Task Force against over-exposure to radiation. With this thought in mind, and after a rather thorough study of the then commercially available instruments, the group submitted its final report to Colonel Cooney on 4 October 1947. A copy of this report will be found in Appendix A. In making recommendations for procurement, the group advised the purchase in greatest numbers of those instruments which were presumably improved models of previous reasonably reliable designs. New relatively untried instruments were recommended in quantities sufficient for adequate testing purposes only.

After conferences with members of the group, the Victoreen Instrument Company agreed to supply a modified ionization chamber instrument capable of reading to 25,000 mr per hour, and the National Technical Laboratories designed and constructed an entirely new ionization chamber instrument. This group also stimulated the production of pocket dosimeters, particularly in the 0-10 r and 0-50 r ranges.

Instruments were purchased by the Instruments Branch, Washington Division of Production, U. S. Atomic Energy Commission, upon request of Colonel Cooney. Delivery of the majority of the instruments was made to Task Group 7.6 at the Terminal Island Naval Shipyard prior to the departure of the USS Bairoko for Eniwetok.

~~RESTRICTED~~

UNCLASSIFIED

In addition to the purchased instruments, the Bureau of Ships, U. S. Navy, loaned a number of Geiger-Mueller survey instruments and portable alpha detectors which they had been developing. These instruments, which were then in the developmental stage, were taken for testing purposes only and were not issued to monitors for use in radiation health protection.

III FACILITIES AVAILABLE

The after ready room of the USS Bairoko, CVE-115, was made available for instrument storage, repair, and testing. This room was an air-conditioned space of about 615 sq. ft. which allowed room for storage racks, instrument repair facilities, and the radiation counting laboratory. Instruments used by Task Unit 7.6.1 in limited quantities for health protection of the air operations from Kwajalein were stored in a refrigerator with a volume of approximately 165 cubic feet. The refrigerator was kept at a temperature of 105° F by means of a 150-watt light bulb. Silica gel bags placed throughout the interior kept the relative humidity generally in the range of 15 to 20 per cent. Only minor repairs and adjustments were accomplished at Kwajalein. All major work was taken to the laboratory on the USS Bairoko.

The following personnel were given full-time assignments to instrument repairs and testing and to the counting laboratory:

- Andrews, Howard L., CDR, USPHS
- Fasio, Michael, CETM, USN
- Kramer, Harry, CETM, USN
- Mademann, Paul F., CETM, USN
- Wensler, Carl, civilian

[REDACTED] UNCLASSIFIED

Murphy, Norris F., LT, USN

Murphy, Raymond E., civilian

Schappacher, Robert N., ETMI, USN

This group was supplemented by personnel having additional duties to their normal assignments and an occasional individual assigned from time to time.

Mr. Adrian H. Dahl, Chief, Instruments Branch, USAEC, although present for a short period of time, made a valuable written report on his observations on instrument performance (1).^{*} At Kwajalein, Malcolm A. Hormats, Capt., USAF, and William S. Matthews, Capt., USAF, were charged with the responsibility of testing instruments in the air. A chief electronics technician's mate was assigned additional duties from time to time for maintenance of instruments at Kwajalein.

Instruments were calibrated in terms of radium sealed in the equivalent of 0.5 mm of platinum. Sources of nominal values of 25, 50, 100, and 250 milligrams were available. Each of these had been calibrated by the National Bureau of Standards within the previous year. The after end of the flight deck of the USS Bairoko was used for calibrations. This provided a satisfactory space relatively free from scattering, except on occasions when airplanes were stored close to the calibrating area.

IV INSTRUMENTS AVAILABLE

The following instruments were delivered to the USS Bairoko for testing and for use in radiological monitoring operations. The detailed characteristics of some of these instruments are given in Tables I, II, and III. Figures 1 through 9 are photographs of the instruments. A tabulation of numbers and types of instruments is given below.

*Numbers in parentheses indicate references on Page 35 of this report.

[REDACTED] UNCLASSIFIED

UNCLASSIFIED

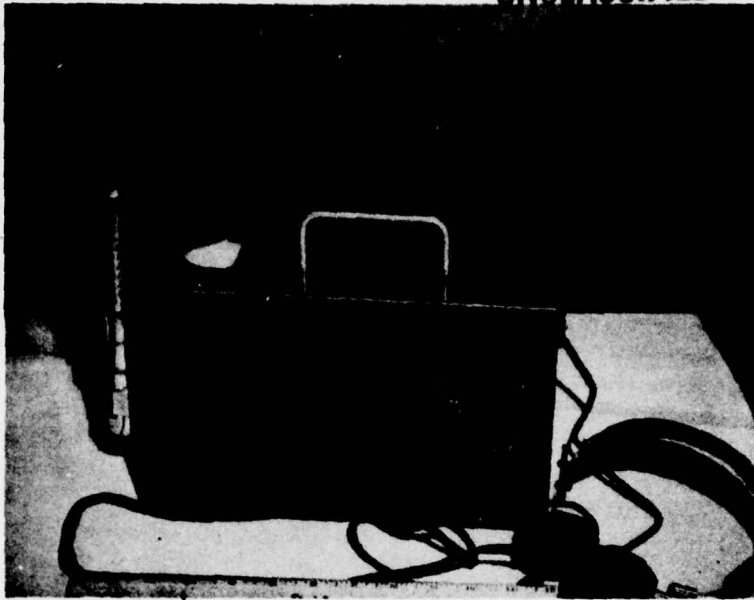

FIGURE 1 - INSTRUMENT DEVELOPMENT LABORATORY MODEL 2610

This Geiger counter has a detachable probe mounted vertically at one end of the instrument case. The operating switch is at the opposite end of the case top from the meter.

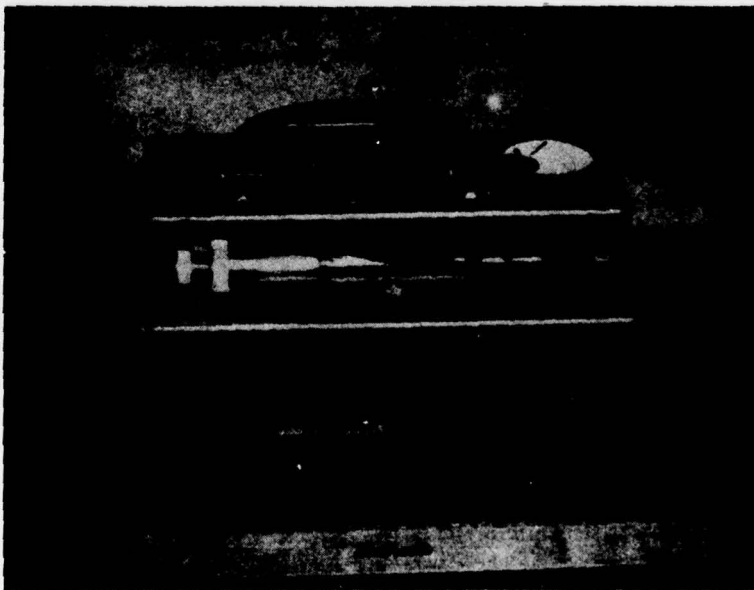

FIGURE 2 - NATIONAL TECHNICAL LABORATORIES MODEL MX-5

The probe on this Geiger counter instrument is housed horizontally in a well along the top cover of the case. The flexible handle covers the ear phone receptacle.

UNCLASSIFIED

UNCLASSIFIED

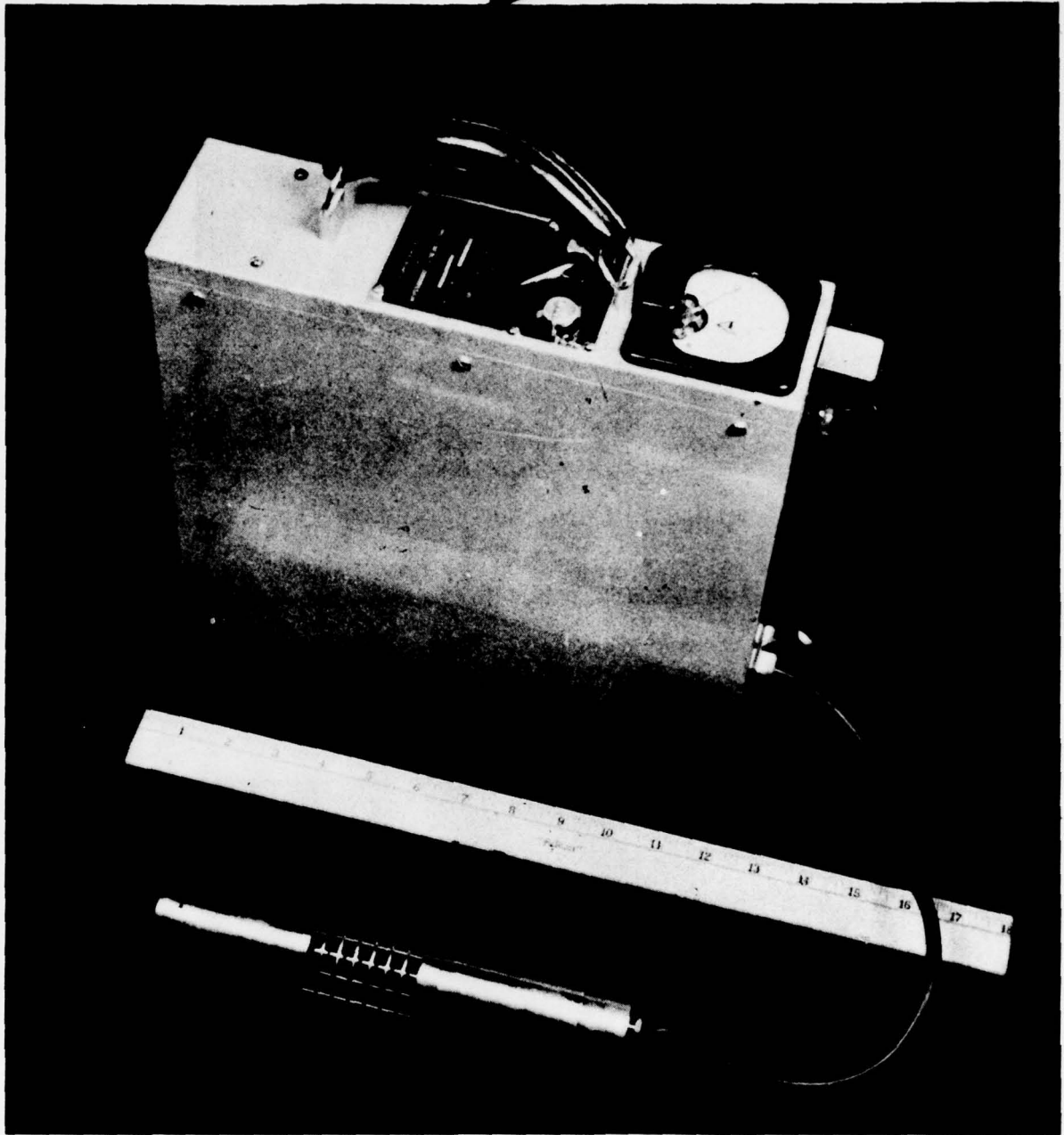
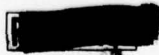

FIGURE 3 - VICTOREEN INSTRUMENT COMPANY MODEL 263A

This Geiger counter has a detachable probe mounted vertically along one end of the instrument case. The switch and phone jack are located mid-case under the handle.

UNCLASSIFIED



A GEIGER-MUELLER SURVEY INSTRUMENTS

MANUFACTURER	TYPE	NUMBER	RANGES (mr/hr)
Instrument Development Laboratories*	2610	25	0.2
			2.0
			20
National Technical Laboratories	MX-5	25	0.2
			2.0
			20
Victoreen Instrument Company	263A	100	0.2
			2.0
			20
Bureau of Ships	AN/PDR-1	15 (halogen G-M tube)	
	AN/PDR-8	1 (halogen G-M tube)	

B IONIZATION CHAMBER SURVEY INSTRUMENTS

MANUFACTURER	MODEL	NUMBER	SENSITIVE TO	RANGES (mr/yr)
National Technical Laboratories	MX-2	10	x-ray, gamma, beta	20
				50
				200
	MX-6	20	x-ray, gamma	500
				2000
				5
Rauland Manufacturing Company	Z-100A	20	x-ray, gamma	50
				100
				20
	Z-100	20	x-ray, alpha, beta, gamma	4
				100
				20

*On 1 September 1948 the Instrument Development Laboratories changed their name to the "Nuclear Instrument and Chemical Company."

UNCLASSIFIED

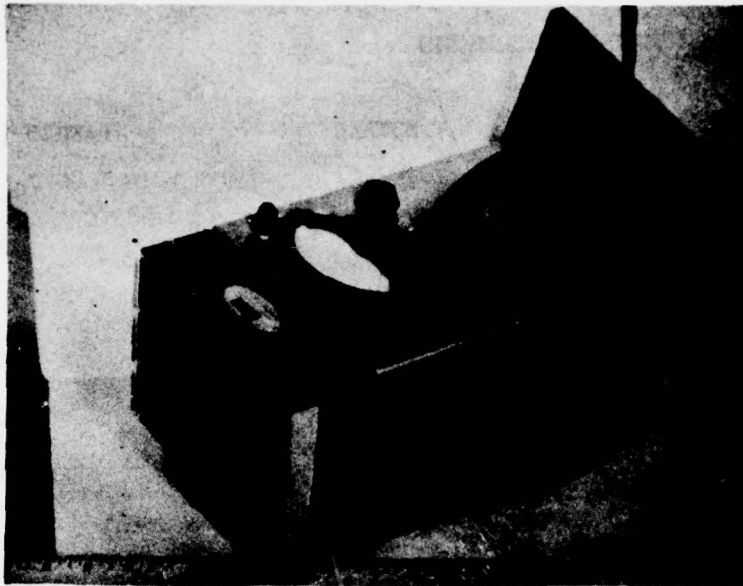

FIGURE 4 - NATIONAL TECHNICAL LABORATORIES MODEL MX-2

An ion chamber with a thin window capable of measuring beta rays is shown, with gamma shield removed on the end of this instrument.

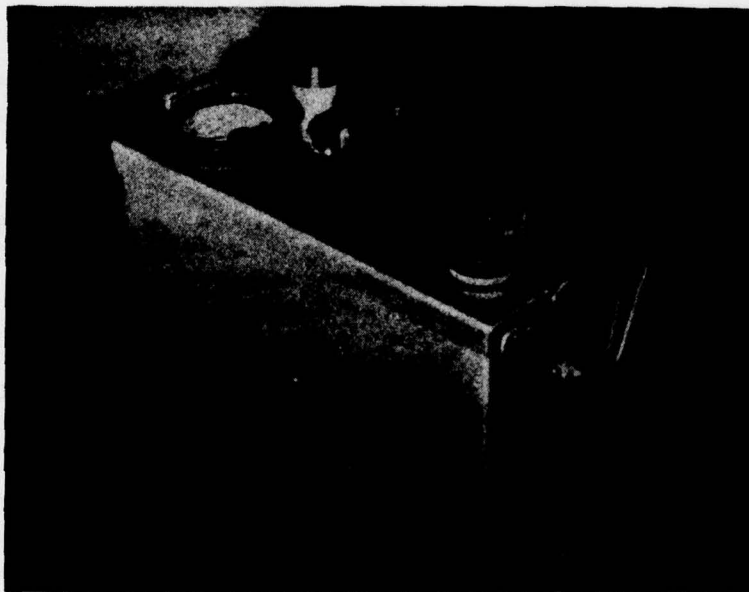

FIGURE 5 - NATIONAL TECHNICAL LABORATORIES MODEL MX-6

This instrument contains a sealed ion chamber located beneath the meter. The control switch is at mid-case. Full scale ranges are 5, 50, 500, and 5000 mr per hour.

~~SECRET~~

UNCLASSIFIED

UNCLASSIFIED

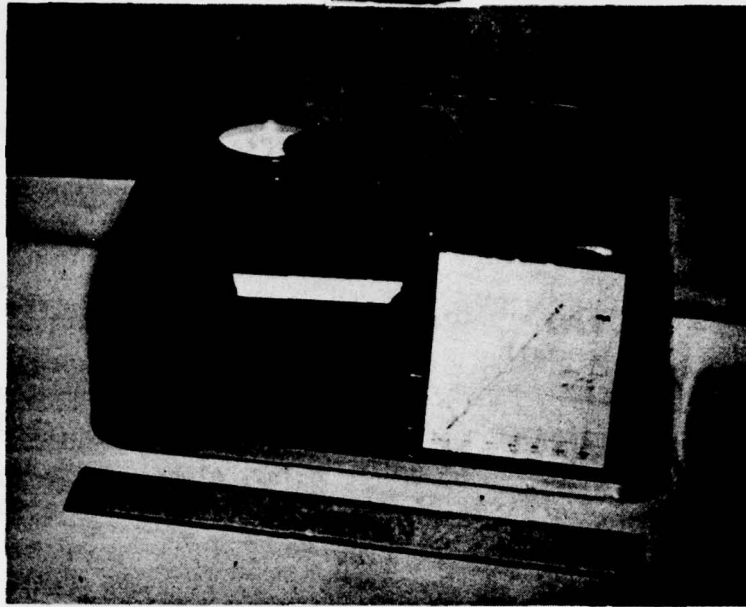

FIGURE 6 - RAULAND ZEUS

The Model Z-100 shown here has movable shields on the bottom of the instrument which cover a chamber capable of alpha, beta, and gamma measurements. The Model Z-100A is a chamber for gamma measurements only.

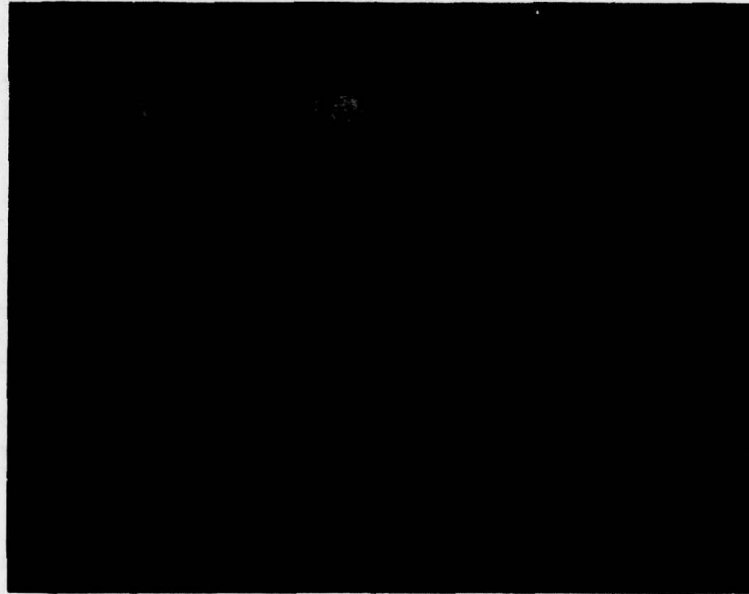
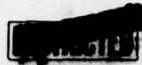

FIGURE 7 - VICTOREEN INSTRUMENT COMPANY MODEL 247A

This instrument contains a gamma chamber directly beneath the meter. Switches under the handle are for battery check, range set, and zero adjustment. The top reading on this instrument is 2500 mr per hour. The Model 247A(Special) was designed for a top reading of 25,000 mr per hour.

UNCLASSIFIED

UNCLASSIFIED



MANUFACTURER	TYPE	NUMBER	SENSITIVE TO	RANGES (mr/hr)
Victoreen Instrument Company	247	12	x-ray, gamma	
	247A	50	x-ray, gamma	2.5 25 250 2500
	247A (Special)	10	x-ray, gamma	25 250 2500 25000
	356	10	x-ray, alpha, beta, gamma	400 alpha/min. 40000 alpha/min.

C INTEGRATING DOSE METER

MANUFACTURER	MODEL	NUMBER	RANGE	COLOR	DESCRIPTION
A. O. Beckman Company		50	0.2 r	silver	Direct reading quartz fibre ion chamber, hermetically sealed, charged through mov- able diaphragm.
Cambridge Instrument Company		200	0.2 r	grey	Essentially the same as K-100.
Kelley-Koett Manufacturing Company	K-100	600	0.2 r	black	Direct reading quartz fibre ion chamber.
	K-150	113	10 r	blue	Same as K-100 with condenser to reduce sensitivity.
	K-160	25	50 r	red	Same as K-100 with condenser to reduce sensitivity.
National Technical Laboratories	NK-7				Pocket integrating ion chamber with auto- matic audible alarm at predetermined dose.
Victoreen Instrument Company	300(Protex- imeter)	20	200 mr full scale		Non-portable inte- grating ion chamber for recording total exposure at a location.

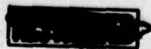

UNCLASSIFIED

UNCLASSIFIED

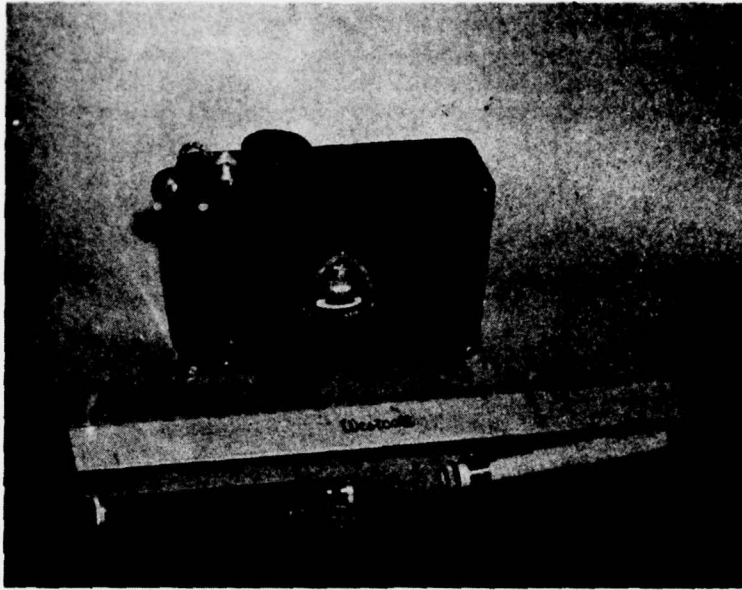

FIGURE 8 - GAMMA DOSIMETERS AND CHARGER

- a. Lower left is a Kelley-Koett Model K-100 dosimeter having a full scale range of 200 mr. The size and shape is identical to the Kelley-Koett Models K-150 and K-160 having full scale readings of 10 and 50 r.
- b. The Cambridge Instrument Company 200 mr dosimeter is shown at the lower right.
- c. The Kelley-Koett dosimeter charger Model K-135 is shown at the top of the figure. For charging, the dosimeter is placed in the receptacle at the far left top of the box. Control of charge is maintained by the large knob next to the charging receptacle.

RESTRICTED

UNCLASSIFIED

UNCLASSIFIED

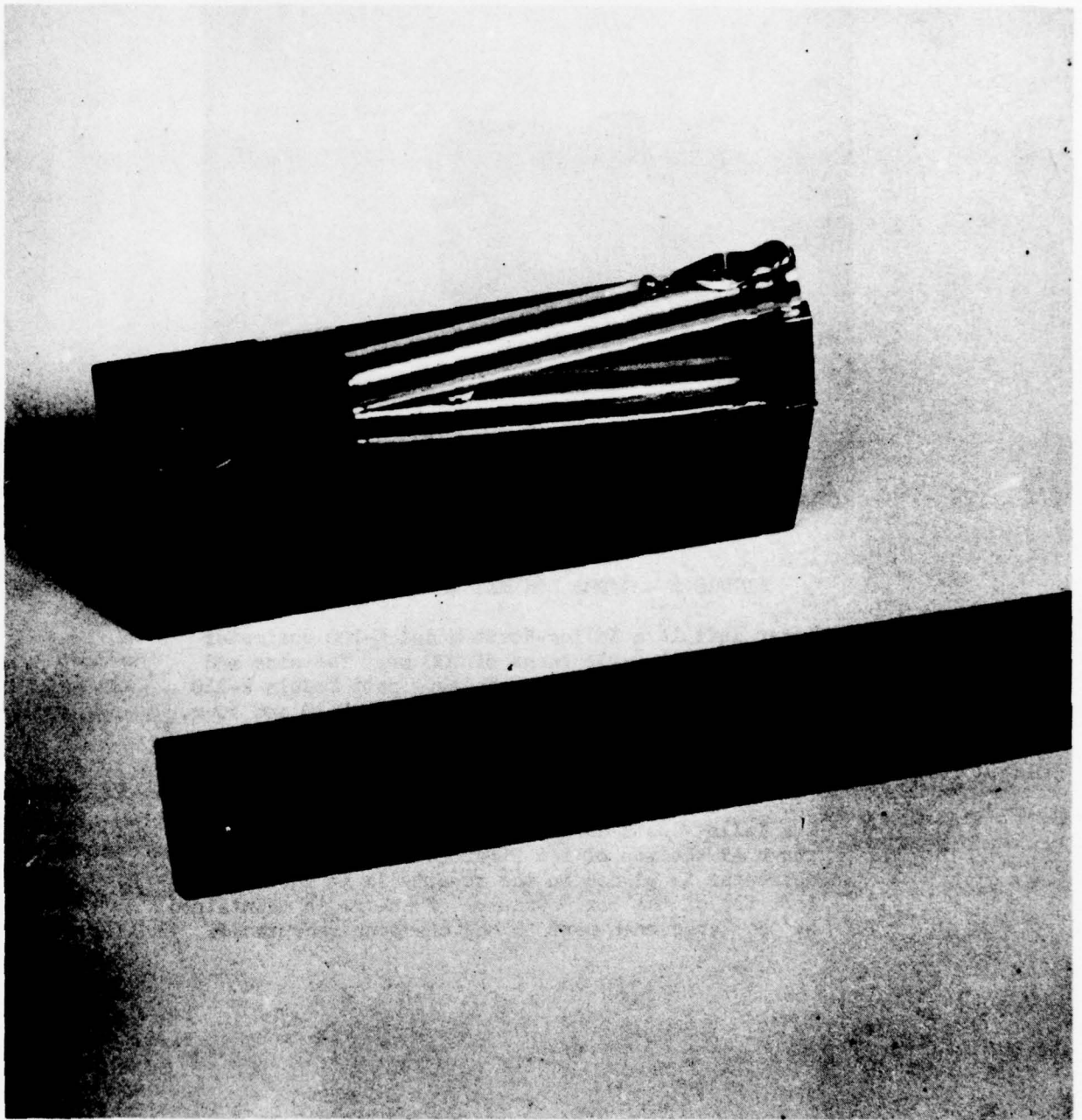

FIGURE 9 - A. O. BECKMAN COMPANY 200 mr DOSIMETER
(PICTURED WITH CHARGER)

This is a direct reading pocket electroscope four
inches long and 0.5 inches in diameter.

UNCLASSIFIED

UNCLASSIFIED

RESTRICTED

UNCLASSIFIED

D OTHER INSTRUMENTS

MANUFACTURER	MODEL	NUMBER	DESCRIPTION
A. O. Beckman Company		5	Dosimeter Charger
Cambridge Instrument Company		10	Dosimeter Charger
Kelley-Koett Manufacturing Company	K-135	72	Dosimeter Charger
Los Alamos Area, AEC	SIC-7 (Watts)	2	Modified Cutie-Pie
	SPC-1B (Pee-Wee)	2	Survey meter incorporating a proportional counter detector.
R.C.A. - Bureau of Ships	AN/PDR-11	2	Photomultiplier alpha detector.
Victoreen Instrument Company	356 (Zute)	20	Portable alpha air ionization chamber - 8000, 80,000 uranium dis/min.

V RESULTS OF FIELD EXPERIENCE WITH RADIOLOGICAL SURVEY INSTRUMENTS

Careful records were kept of all repairs made on the survey instruments in order that statistics might be compiled showing the weak points of the various types. Practically every instrument showed the same type of repair history. The first field use showed weak points which were then corrected for all instruments of that type. After the initial changes had been made, the instrument performance was, in general, satisfactory.

A USE AND REPAIR RECORDS

A summary of the repair records of the Geiger-Mueller and ionization chamber survey meters which were used continuously throughout the operation are

RESTRICTED

UNCLASSIFIED

given below. The information on the length of time of use, as given in these data, is subject to some error in collection. Due to recording omissions, the times given are probably low; however, they give an order of magnitude which should be constant between instruments.

1 GEIGER-MUELLER COUNTERS

a Instrument Development Laboratories Model 2610

(1) Usage Record

Instruments	15
Hours of operation	478
Average hours per instrument	32

(2) Repair Record for 25 Instruments

Replaced G-M tube (IDL D12)	20
Replaced $1\frac{1}{2}$ v battery	5
Replaced $67\frac{1}{2}$ v battery	4
CK-522 tube out of socket	2
Replaced all batteries (one $1\frac{1}{2}$ v, one $67\frac{1}{2}$ v, three 300 v)	1

b National Technical Laboratories Model MX-5

(1) Usage Record

Instruments	10
Hours of operation	654
Average hours per instrument	65

SECRET

UNCLASSIFIED

(2) Repair Record for 25 Instruments

Replaced G-M tube (RGL #k1 Mdl 20)	13
Replaced 45 v battery	19
Replaced 1½ v battery	7
Replaced 105 amplifier tube	5
Replaced all batteries (one 1½ v, two 45 v, three 300 v)	5
Defective power plug	4
Bent tube shield	1
Replaced meter (100 ua)	1

c Victoreen Instrument Company Model 263A

(1) Usage Record

Instruments	55
Hours of operation	880
Average hours per instrument	16

(2) Repair Record for 100 Instruments

Fixed amplifier unit	56
Modified with .0025 ufd range coupling capacitor	56
Replaced meter RC 100 ufd capacitor	55
Replaced G-M tube	22
Replaced 1½ v batteries	17
Replaced entire amplifier unit	14
Replaced 300 v batteries	8

SECRET

UNCLASSIFIED

UNCLASSIFIED

REDACTED

Replaced 67½ v batteries	7
Replaced meter (50 ma)	4
Replaced all batteries (one 1½ v, one 67½ v, three 300 v)	3
Meter shunt lead defective	3
High voltage cable insulation trouble	2
Replaced VI41A multivibrator tube	1
Defective probe connection	1

d Bureau of Ships Types AN/PDR-1 and AN/PDR-8

These instruments had not completed laboratory testing prior to being sent on the operation, and certain difficulties developed which prevented the conduct of any field tests. Information on these instruments has been reported separately (2).

2 IONIZATION CHAMBER SURVEY METERS

a National Technical Laboratories Model MK-2

This instrument, designed for laboratory use, was found not satisfactory for field survey work.

b National Technical Laboratories Model MK-6

(1) Usage Record

Instruments	14
Hours of operation	761
Average hours per instrument	54

UNCLASSIFIED

REDACTED

UNCLASSIFIED

(2) Repair Record for 20 Instruments

As received, the chamber voltage was not sufficient to produce saturation currents when exposed to high radiation intensities. This was remedied by installing an extra 90 volts which could be readily placed inside the case.

Replaced all batteries (four 1½ v, one 3 v,
one 22½ v, two 45 v) 9
Defective battery contact 2
Replaced 2532 tube 1
Short in 2532 tube base 1
Replaced 1½ v battery 1
Replaced 22½ v battery 1

c Rauland Manufacturing Corporation Models Z-100 and Z-100A (Zeus)

This instrument was designed for laboratory use and therefore was found unsuited for field survey work.

d Victoreen Instrument Company Model 247

The obsolete 247 was sent to the operation as an emergency measure to cover possible malfunctioning of the new and untried instruments. These instruments were neither used in the field operations, nor were any tests conducted, since the experience of Operation Crossroads indicated them to be unstable and not desirable for field operations.

e Victoreen Instrument Company Model 247A

(1) Usage Record

Instruments 28
Hours of operation 1196
Average hours per instrument 43

UNCLASSIFIED

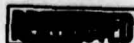

(2) Repair Record for 50 Instruments

The selector switch of the Victoreen type 247A had stops of inadequate strength so that it was very easy to set the switch contacts to an incorrect position. This applied a high voltage to the filament of the electrometer tube which promptly burned out. The repairs required were major ones since the tube was located inside the ionization chamber. This defect was easily corrected by installing positive stop pins. A modified addition of a feedback circuit was made to all instruments upon recommendation by the manufacturer.

Replaced 45 v battery	27
Replaced chamber	14
Replaced 22½ v battery	12
Replaced all batteries (four 22½ v, one 45 v)	6
Broken handle	3
Replaced meter (20 ua)	1
Replaced W-41A-C tube	1

f Victoreen Instrument Company Model 247A (Special)

(1) Usage Record

Instruments	13
Hours of operation	237
Average hours per instrument	24

(2) Repair Record for 10 Instruments

Modify selector switch stops	10
Replace 45 v battery	7

UNCLASSIFIED

Replaced 300 v battery	3
Replaced chamber	1

g Victoreen Instrument Company Model 356

This instrument was included with those for Operation Sandstone for emergency use in the event a serious hazard by alpha activity developed without the presence of beta and gamma. The instrument received no use or formal testing.

3 INTEGRATING POCKET GAMMA DOSIMETERS

a A. O. Beckman Company - 200 mr Full Scale

(1) Usage Record

Number of instruments	43
Number of issues	36

(2) Maintenance Record for 43 Dosimeters

Number of calibrations	32
Broken fibres	1

b Cambridge Instrument Company - 200 mr Full Scale

(1) Usage Record

Number of instruments	67
Number of issues	91

(2) Maintenance Record for 153 Dosimeters

Number of calibrations	110
Bad leakage	65
Unable to focus on fibre	36

UNCLASSIFIED

Scale burned (by sun)	12
Failed to zero	9

c Kelley-Koett Manufacturing Company Model K-100 - 200 mR Full Scale

(1) Usage Record

Number of instruments	362
Number of issues	1683

(2) Maintenance Record for 457 Dosimeters

Number of calibrations	255
Scale burned (by sun)	13
Fibre broken	5
Bad leakage	3
Failed to zero	3

d Kelley-Koett Manufacturing Company Model K-150 - 10 r Full Scale

(1) Usage Record

Number of instruments	80
Number of issues	160

(2) Maintenance Record for 111 Dosimeters

Number of calibrations	309
Excessive leakage	95
Failed to operate - cause unknown	16
Scale burned (by sun)	4
Capacitor separated from electrometer	3
Fibre broken	3

[REDACTED] UNCLASSIFIED

e Kelley-Koett Manufacturing Company Model K-160 - 50 r Full Scale

(1) Usage Record

Number of instruments	25
Number of issues	39

(2) Maintenance Record for 25 Dosimeters

Number of calibrations	18
Scale burned (by sun)	5
Fibre broken	2
Excessive leakage	1
Unable to focus on fibre	1

In practically every case the instruments tested during Operation Sandstone are being redesigned by the manufacturer. Therefore, these repair statistics have been furnished the manufacturers to assist in their new designs.

B DESIGN DEFECTS

Important for future operations are the fundamental design defects which may or may not make an instrument inoperable but which should be improved in future designs. The most important of these defects, which depend on observations rather than the personal preferences of monitors, are listed below:

1 GEIGER-WUELLER SURVEY INSTRUMENTS

a Instrument Development Laboratories Model 2610

G-M tube easily knocked out of holding clips on front of instrument.

G-M tube mounting susceptible to spray with resulting short circuit.

Meter scale divisions too close for rapid reading.

[REDACTED] UNCLASSIFIED

UNCLASSIFIED

b National Technical Laboratories Model MX-5

Non-rigid handle not satisfactory.

Zero set knob too small for operation with gloves.

c Victoreen Instrument Company Model 263A

Narrow case too unstable for field operations.

Range switch poorly placed.

2 IONIZATION CHAMBER SURVEY INSTRUMENTS

a National Technical Laboratories Model MX-2

Non-rigid handle not satisfactory.

Instrument too heavy for field use.

b National Technical Laboratories Model MX-6

Non-rigid handle not satisfactory.

Zero set knob too small for operation with gloves.

Battery connections not sufficiently rigid.

c Rauland Manufacturing Corporation Models Z-100 and Z-100A

Operation unsatisfactory because of moisture entering through and around the thin window.

d Victoreen Instrument Company Models 247A and 247A(Special)

Instrument too heavy for field use.

Zero set knob located in a relatively inaccessible position and difficult to operate with gloves.

Narrow case too unstable for field operations.

UNCLASSIFIED

UNCLASSIFIED

- e Victoreen Instrument Company Model 356

Unsatisfactory for alpha measurements of fission products because of substantial beta-gamma response.

3 INTEGRATING DOSE METERS

- a A. O. Beckman Company - 200 mr Full Scale

Difficult to charge exactly to zero.

Considerable geotropic effect.

Somewhat too fragile.

- b Cambridge Instrument Company - 200 mr Full Scale

Scale easily burned by the sun.

Too much light required to read scale.

- c Kelley-Koett Manufacturing Company Model K-100 - 200 mr Full Scale

Scale easily burned by the sun.

Instrument very sensitive to moisture.

Too much light required to read scale.

- d Kelley-Koett Manufacturing Company Model K-150 - 10 r Full Scale

Scale easily burned by the sun.

Very high leakage.

- e Kelley-Koett Manufacturing Company Model K-160 - 50 r Full Scale

Scale easily burned by the sun.

High leakage.

UNCLASSIFIED

UNCLASSIFIED

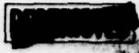

f National Technical Laboratories Model FX-7 (Pocket Alarm)

Failure to trip alarm under field conditions.

Alarm seldom heard under field conditions.

g Victoreen Instrument Company Model 300

Instrument satisfactory but of little practical use.

VI TESTS AND RESULTS

A few simple tests were conducted to bring out various specific characteristics. Some of these, such as life tests, could not be completed, because it was not possible to start them until the main phases of the operation had been completed. A summary of detailed characteristics is given of three types of Geiger-Mueller survey instruments in Table I, of four types of ionization chamber survey meters in Table II, and of five gamma pocket dosimeters in Table III.

UNCLASSIFIED

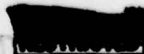

TABLE I

UNCLASSIFIED

CHARACTERISTICS OF GEIGER-MUELLER SURVEY METER

CHARACTERISTICS	Instrument Development Labs. 2610	National Technical Labs. MK-5	Victoreen Instrument Co. 263A
A PHYSICAL			
Weight (pounds)	11.6	9.0	13.4
Tilt from vertical to tip-over (degrees)	28	40	17
Case dimensions - length x width x height (inches)	11x4x6 (exclus- ive of probe)	9½x4-5/8 x5½	12x3½x10 (exclus- ive of probe)
Probe - length x diameter (inches)	9x1½	8x1	9x1½
Case finish	smooth paint	smooth paint	smooth paint
Handle	smooth paint	hinged smooth plastic	hinged shiny leather
B ELECTRICAL			
Radiation detected	beta gamma	beta gamma	beta gamma
G-M tube	IDL D-12	RCL MK1, Mdl 20B	VG-19
Tube wall thickness (mm)	glass-30	glass-30 plastic-17	glass-30
Ranges of gamma sensitivity (mr/hr)	0.2, 2.0, 20	0.2, 2.0, 20	0.2, 2.0, 20
Headphones	crystal	magnetic	crystal
Ability to zero in field	none	none	none
Metering time constant (seconds)	6	2	2
Microphonics	none	none	none

UNCLASSIFIED

UNCLASSIFIED

~~RESTRICTED~~

CHARACTERISTICS

	Instrument Development Labs. 2610	National Technical Labs. NK-5	Victoreon Instrument Co. 263A
Zero fluctuations per second (G-M tube detached)	0	0	0
Zero drift per hour	0	0	0
Temperature effect	none noted	none noted	none noted
Light sensitivity	some G-M tubes	none	some G-M tubes
Wind sensitivity	none	none	none
Air pressure sensitivity	none	none	none
Useful operating life (hours)	230	200	85
Saturation effects	none	none	none
Warm-up period	0	0	0
Sensitivity variation (per cent per hour)	.08	0.2	.05

UNCLASSIFIED

~~RESTRICTED~~

TABLE II

CHARACTERISTICS OF IONIZATION CHAMBER SURVEY METERS

CHARACTERISTICS	National Technical Labs. MX-2	National Technical Labs. MX-6	Rauland Mfg. Corp. Z-100 and Z-100A	Victoreen Instrument Co. 247A and 247A(Special)
A PHYSICAL				
Weight (pounds)	14.2	8.0	10.3	12.8
Tilt from vertical to tip-over (degrees)	52	40	50	18
Case dimensions - length x width x height (inches)	12½x7½x6½	9½x4-7/8 x6	12½x7x8	10-3/8x5-3/8 x13
Case finish	smooth paint	smooth paint	smooth plastic	smooth paint
Handle	hinged smooth plastic	hinged smooth plastic	rigid anodized metal	rigid painted metal
B ELECTRICAL				
Radiation detected	beta, gamma	gamma	alpha, beta gamma, and gamma only	gamma
Range of gamma sensitivity (mr/hr)	20, 50, 200, 500, 2000	5, 50, 500, 5000	25, 100, 500, 2500	2.5, 25, 250, 2500 and 25, 250, 2500, 25,000
Ability to zero in field	none	satisfac- tory	satisfac- tory	satisfac- tory
Metering time constant (seconds)	0.5	1	1	2
Microphonics	none	none	none	none
Zero fluctuations per second	0	0	0	0

UNCLASSIFIED

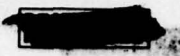

CHARACTERISTICS

National Technical Labs. MX-2 National Technical Labs. MX-6 Reuland Mfg. Corp. 7-100 and Z-100A Victoreen Instrument Co. 247A and 247A(Special)

Zero drift per hour (per cent of full scale)	±1	-1	±1	±3
Temperature effect	none	none	none	none
Light sensitivity	none	none	none	none
Wind sensitivity	none	none	bad	none
Air pressure sensitivity	sensitive	reduced	sensitive	very sensitive
Scale linearity	linear	linear (after added voltage)	linear	linear
Useful operating life (hours)	400	200	200	30
Warm-up period (minutes)	1	1	1	8
Sensitivity variations (per cent per hour)	less than .05	less than 0.1	less than .02	less than 1.0
Saturation effects noted	none	none (after added voltage)	none	none



UNCLASSIFIED

TABLE III

CHARACTERISTICS OF GAMMA POCKET DOSIMETERS

CHARACTERISTICS	A.O. Beckman Company	Cambridge Inst. Co.	Kelley-Koett Mfg. Co. K-100	Kelley-Koett Mfg. Co. K-150	Kelley-Koett Mfg. Co. K-160
A PHYSICAL					
Weight (ounces)	0.6	0.6	0.6	0.6	0.6
Length (inches)	4	5	5	5	5
Outside diameter (inches)	0.5	0.5	0.5	0.5	0.5
Case finish	smooth metal	anodized metal	anodized metal	anodized metal	anodized metal
Clarity of scale	excellent	poor	good	good	good
Effect of sun on scale	none	burned	burned	burned	burned
Drop test	unable to withstand 3- foot drop	good	good	good	good
Spin stability	excellent	some loose	some loose	some loose	some loose
Ease of repair	not repairable	with difficulty	with difficulty	with difficulty	with difficulty
B OPERATIONAL					
Radiation detec- ted	gamma	gamma	gamma	gamma	gamma
Full-scale sensi- tivity (r)	0.2	0.2	0.2	10	50
Calibration correction factor (%)	-19	-2	-8	-6	-8

UNCLASSIFIED



CHARACTERISTICS

A.O. Beckman Company

Cambridge Inst. Co.

Kelley-Koett Mfg. Co. K-100

Kelley-Koett Mfg. Co. K-150

Kelley-Koett Mfg. Co. K-160

Linearity of calibration

falls off 19% of full scale from mid-scale to full scale

good

good

good

good

Wave length characteristics

suspected of having some dependence

appears independent

appears independent

appears independent

appears independent

Charging capacity shift (% full scale)

3.6

3.5

2.6

less than 1.0

less than 1.0

Graduation shift due to 90° rotation (% of full scale)

7.0

2.6

2.0

2.7

2.3

Leakage zero drift in 24 hours (% of full scale)

1.9

2.2

1.0

1.0

less than 1.0

Waterproofing

excellent

none

none

none

none

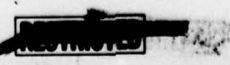

UNCLASSIFIED

A USEFUL OPERATING LIFE

Fresh batteries (and G-M tubes) were installed and the meters put in a fixed geometrical relation to a radium source so that about half scale deflection was obtained. The meters were left on continuously until failure or the termination of the test. The zero was reset before each reading so that the curves shown in Figures 10 through 16 represent changes in instrument sensitivity with life. It should be noted in Figure 11 that the test of the MX-5 is not representative because of the failure of the G-M tube and lack of time to complete the tests.

Instrument	Figure
Geiger-Mueller counters	
Instrument Development Laboratories Model 2610	10
National Technical Laboratories Model MX-5	11
Victoreen Instrument Company Model 263A	12
Ionization chambers	
National Technical Laboratories Model MX-2	13
National Technical Laboratories Model MX-6	14
Rauland Manufacturing Corporation Model Z-100A	15
Victoreen Instrument Company Model 247A (Special)	16

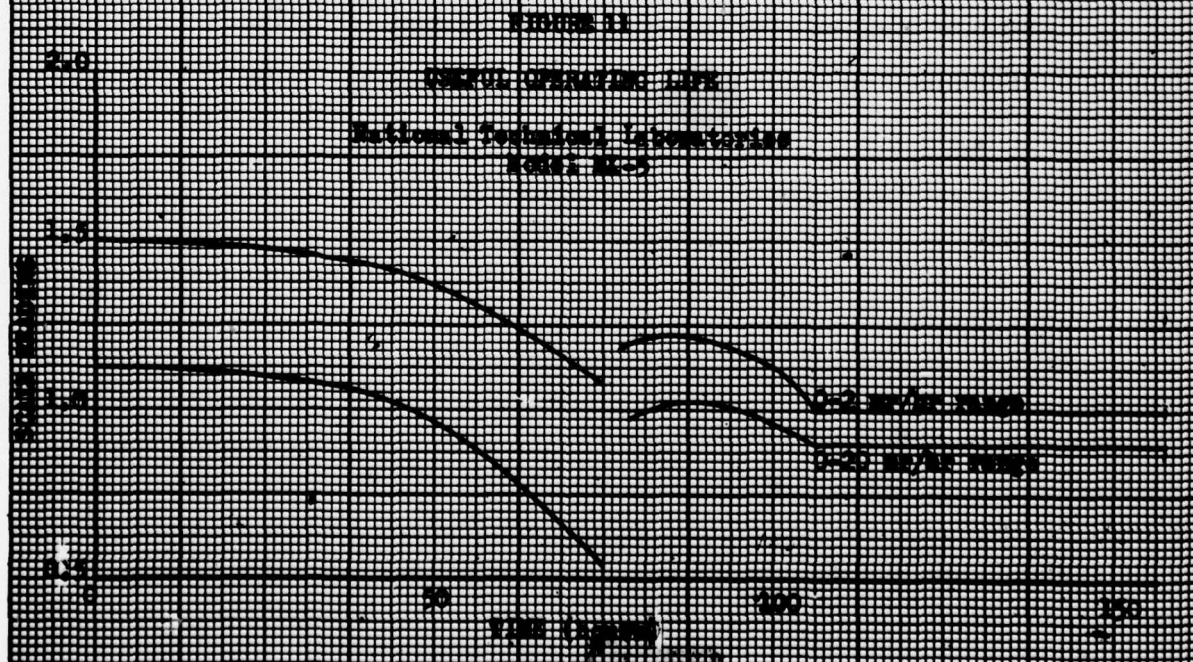
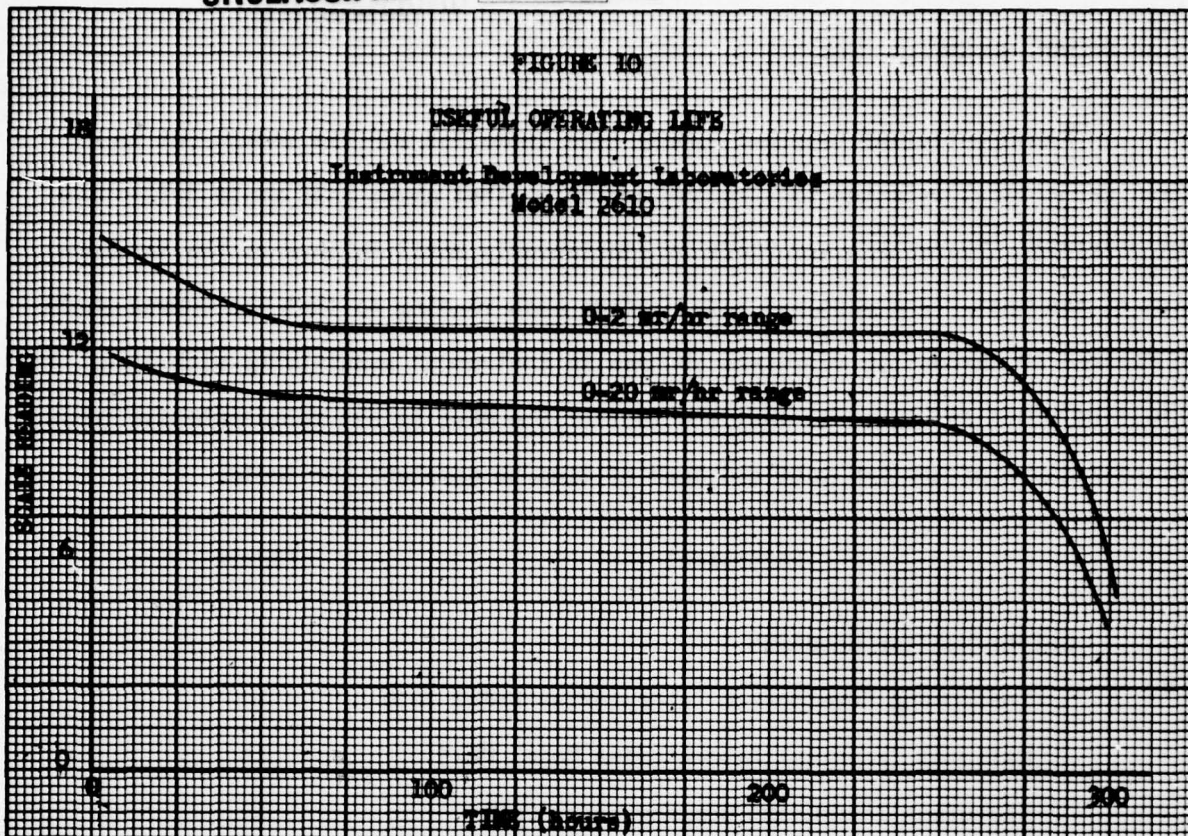

UNCLASSIFIED

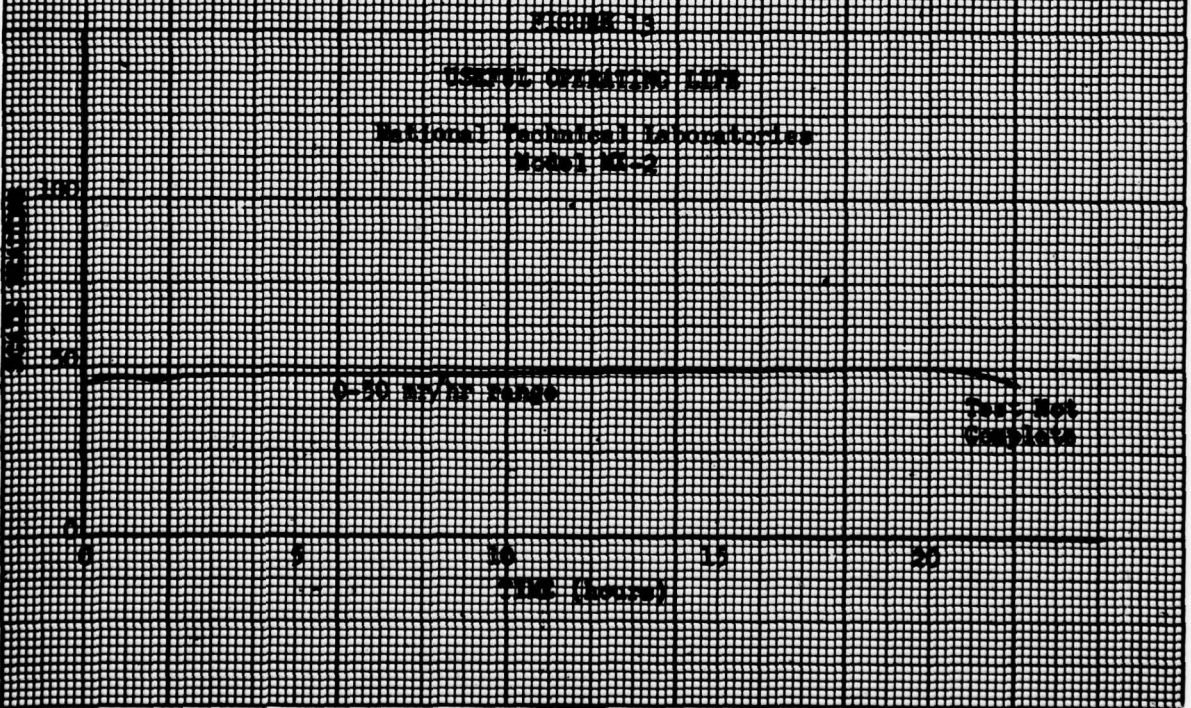
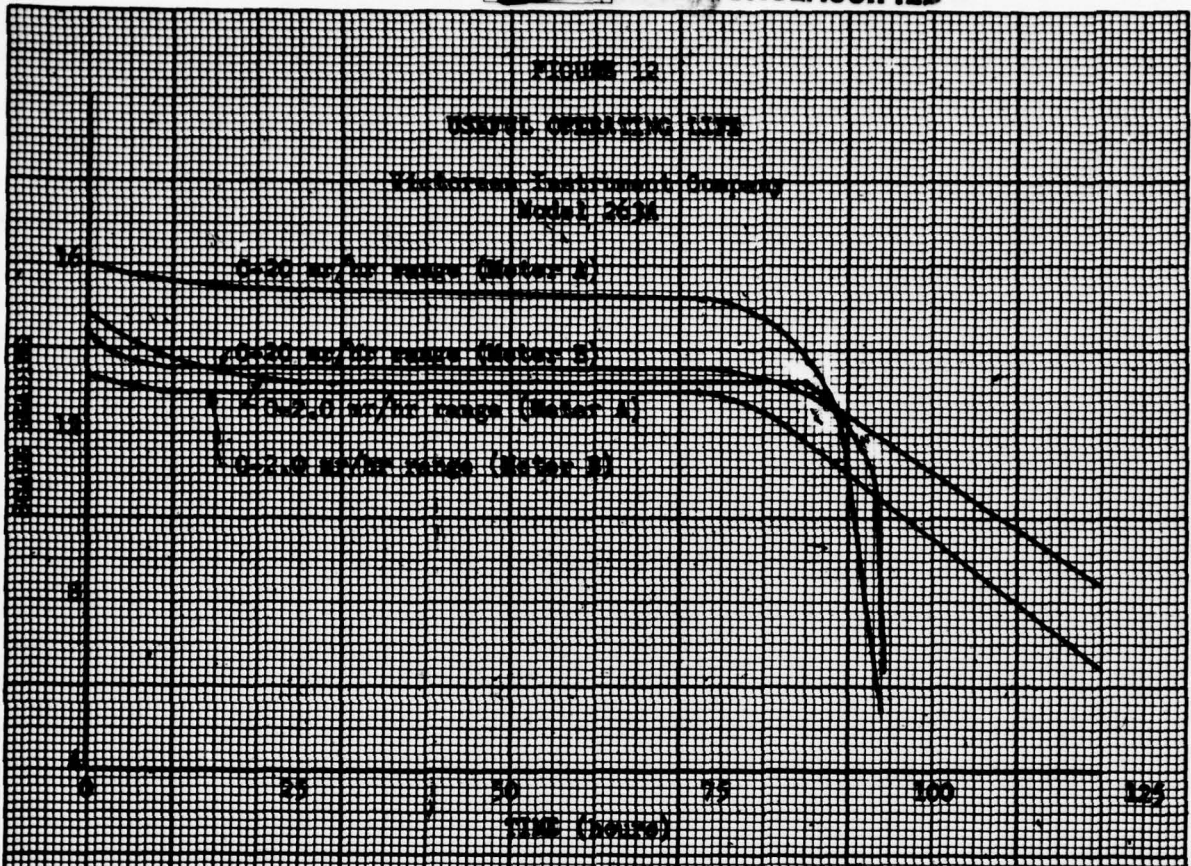

B LINEARITY OF RESPONSE

Using standard sources of radium and carefully measured distances, each scale range was checked for linearity of response. The results are shown in Figures 17 through 22. After the tests were completed, the lack of linearity in the Type 263A was found to be due to a factory-installed long time constant electronic circuit combined with a poor amplifier tube. Many of these instruments were assembled in this fashion. When an amplifier tube of proper sensitivity was installed, the circuit time constant could be reduced, and the response became much more linear. Unfortunately, the data for the improved-response curve are not available.

It will also be noted in Figure 21A that the MX-6 as received from the factory was quite non-linear on the upper ranges. This was corrected by an additional 90 volt battery as shown in Figure 21B.

Instrument	Figure
Geiger counters	
Instrument Development Laboratories Model 2610	17
National Technical Laboratories Model FX-5	18
Victoreen Instrument Company Model 263A	19
Ionization chambers	
National Technical Laboratories Model FX-2	20
National Technical Laboratories Model MX-6 (as received)	21A
National Technical Laboratories Model MX-6 (90 v added)	21B
Victoreen Instrument Company 247A	22

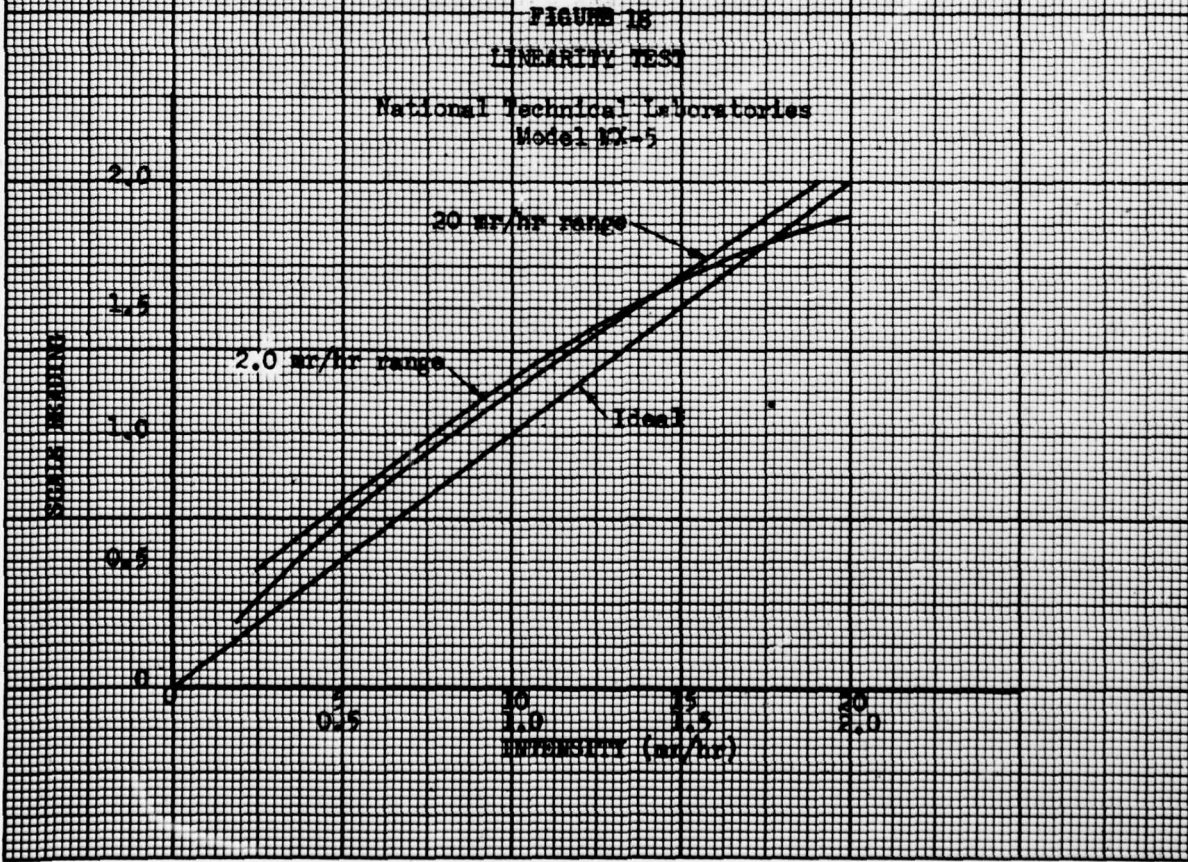
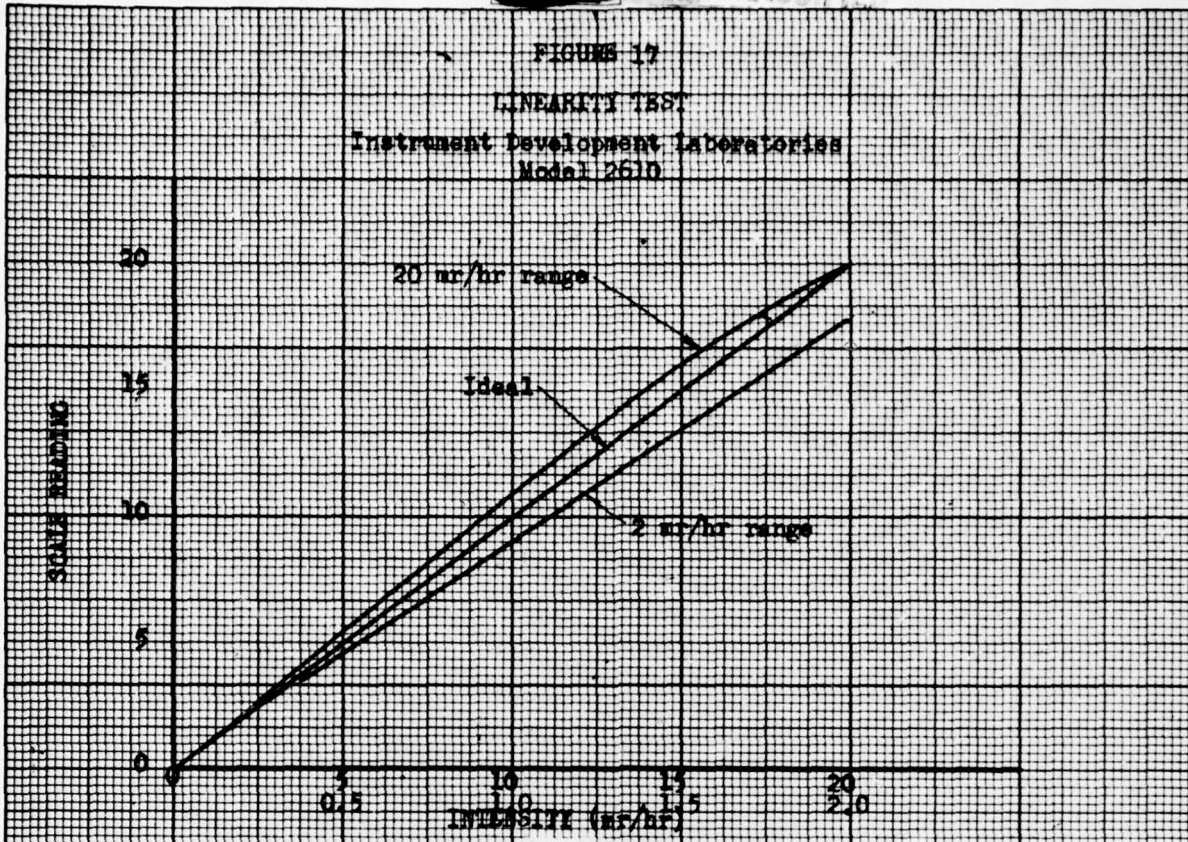
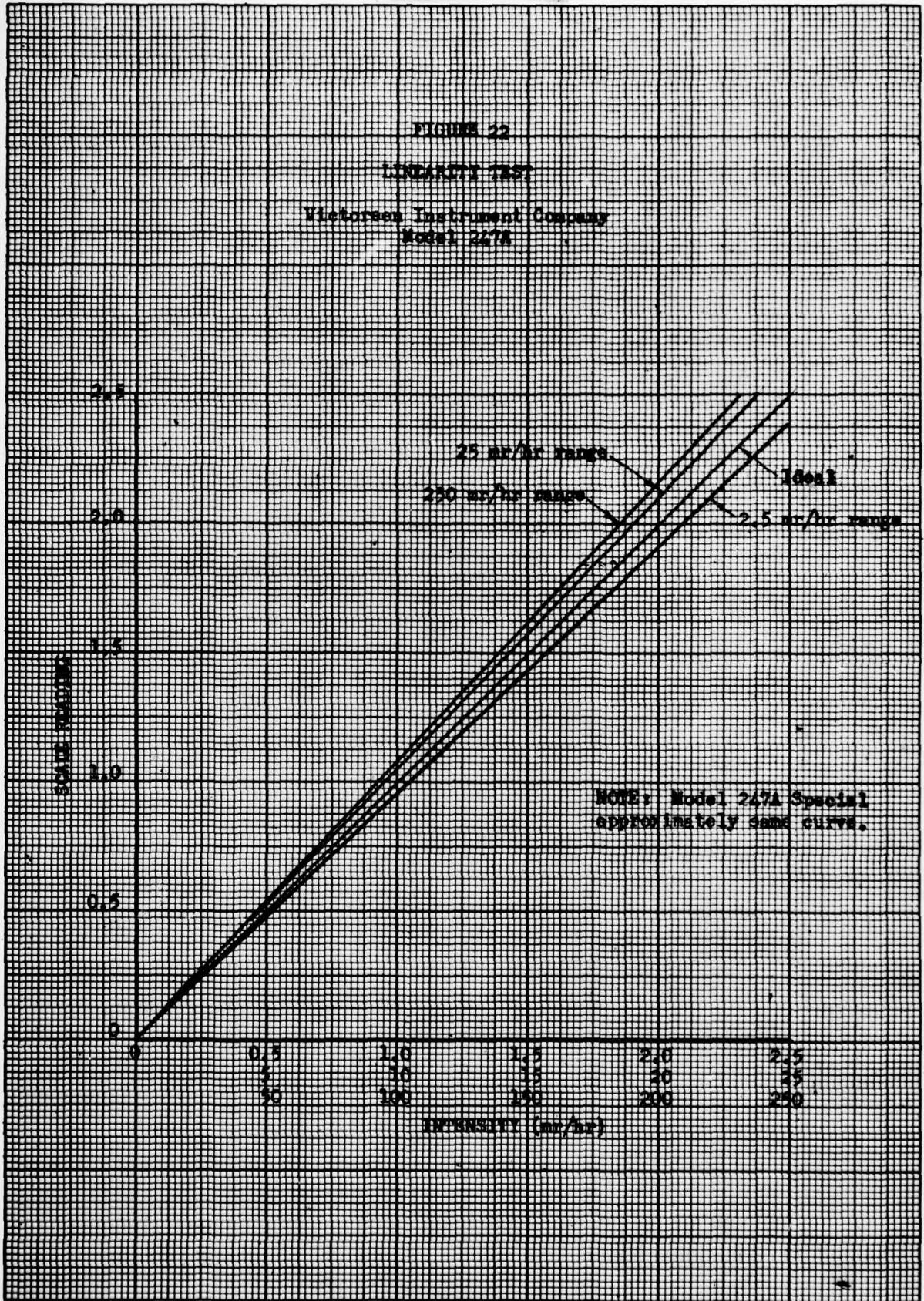

FIGURE 22
LINEARITY TEST
Victorson Instrument Company
Model 247A



C DIRECTIONAL RESPONSE

The instruments were located at a fixed distance from a point source of radium and rotated, and readings were taken at regular intervals. The response curves are shown in Figures 23 through 32.

Instrument	Figure
Geiger counters	
Instrument Development Laboratories Model 2610 (normal orientation)	23
Instrument Development Laboratories Model 2610 (on side)	24
National Technical Laboratories Model NX-5 (normal orientation)	25
National Technical Laboratories Model NX-5 (on side)	26
Victoreen Instrument Company Model 263A (normal orientation)	27
Victoreen Instrument Company Model 263A (on side)	28
Ionization chambers	
National Technical Laboratories Model NX-6 (normal orientation)	29
National Technical Laboratories Model NX-6 (on side)	30
Victoreen Instrument Company Model 247A and 247A(Special) (normal orientation)	31
Victoreen Instrument Company Model 247A and 247A(Special) (on side)	32

UNCLASSIFIED

[REDACTED]

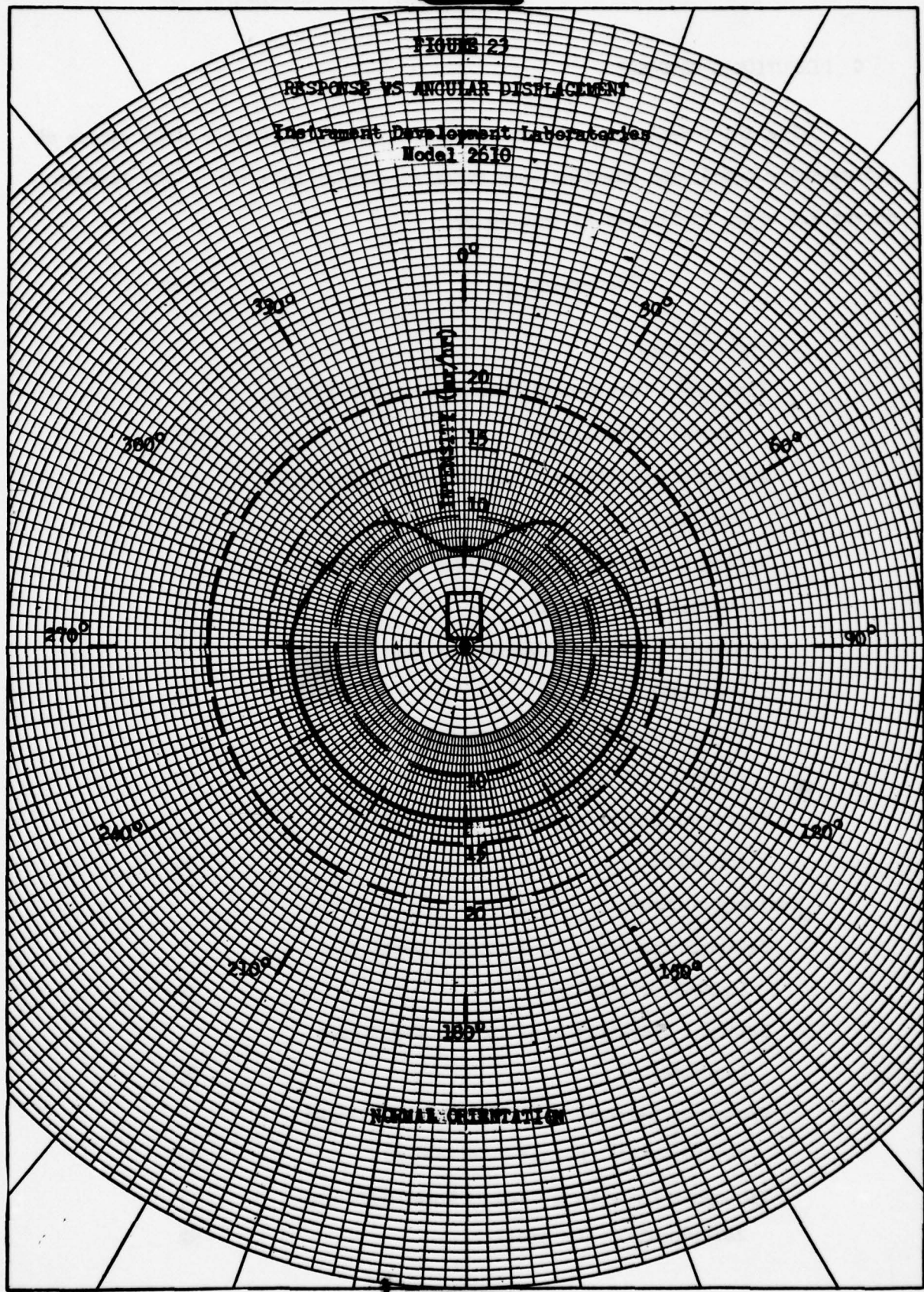

[REDACTED]

UNCLASSIFIED

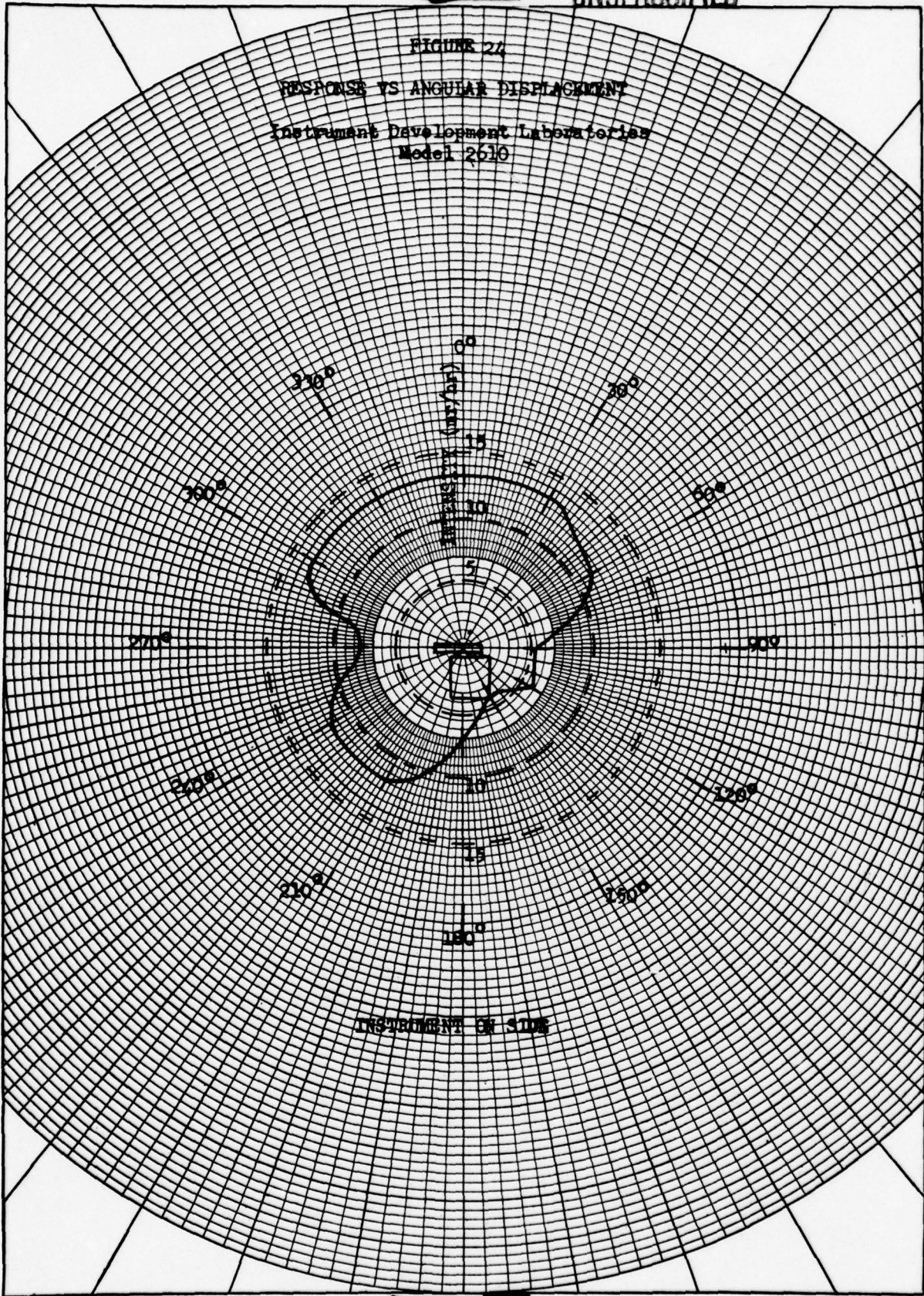

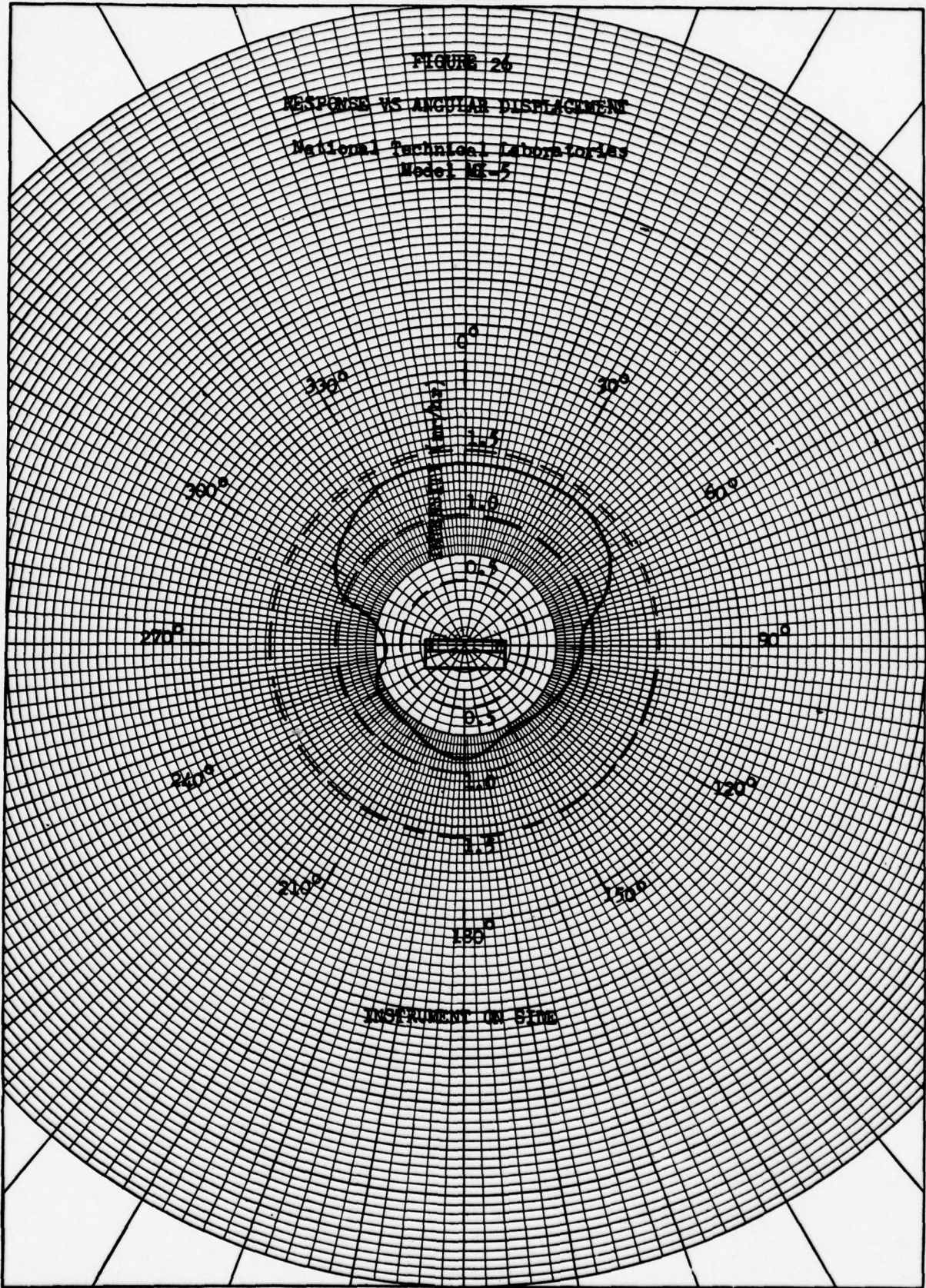

TOP SECRET

UNCLASSIFIED

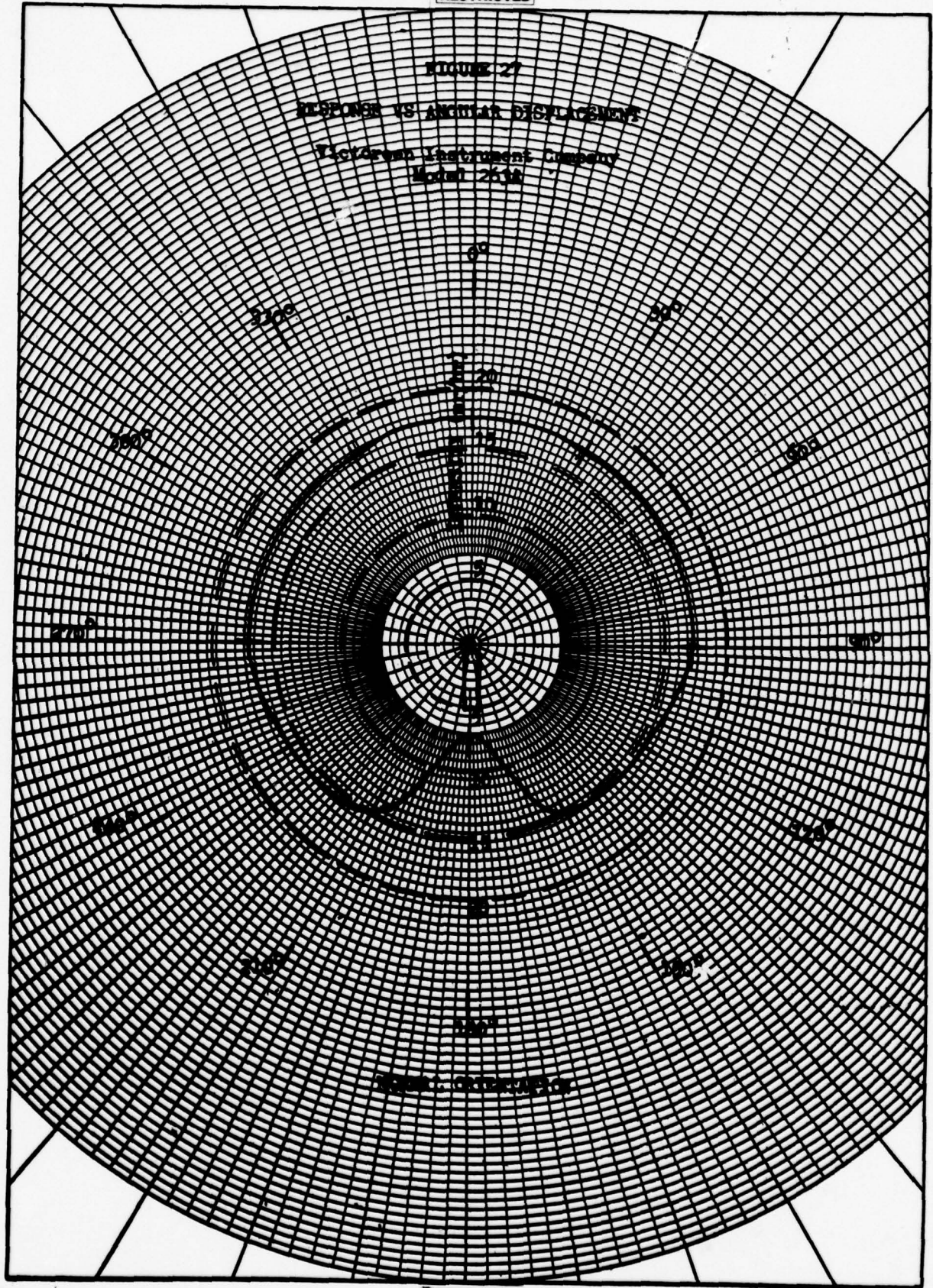

TOP SECRET

UNCLASSIFIED

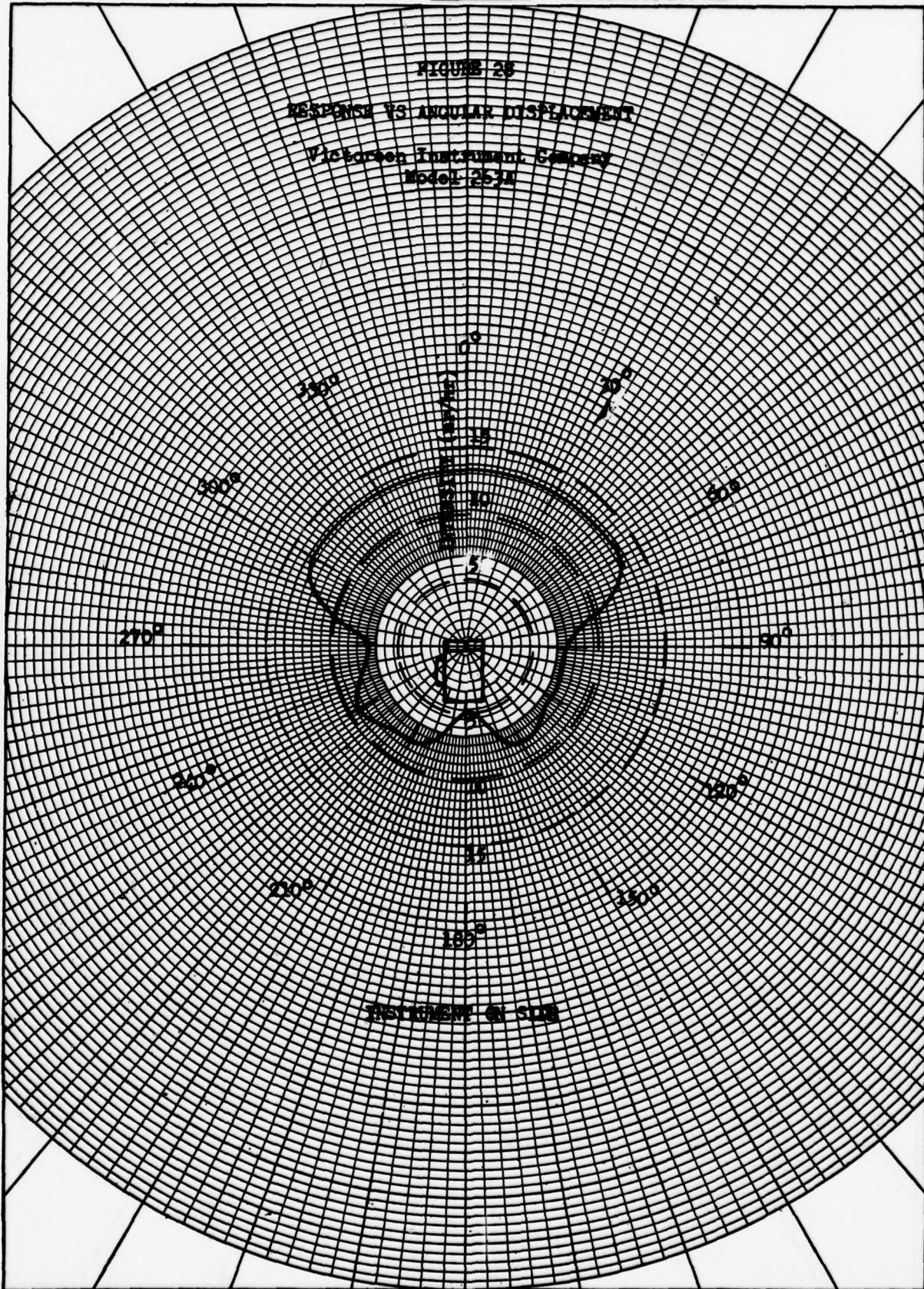

~~RESTRICTED~~

UNCLASSIFIED

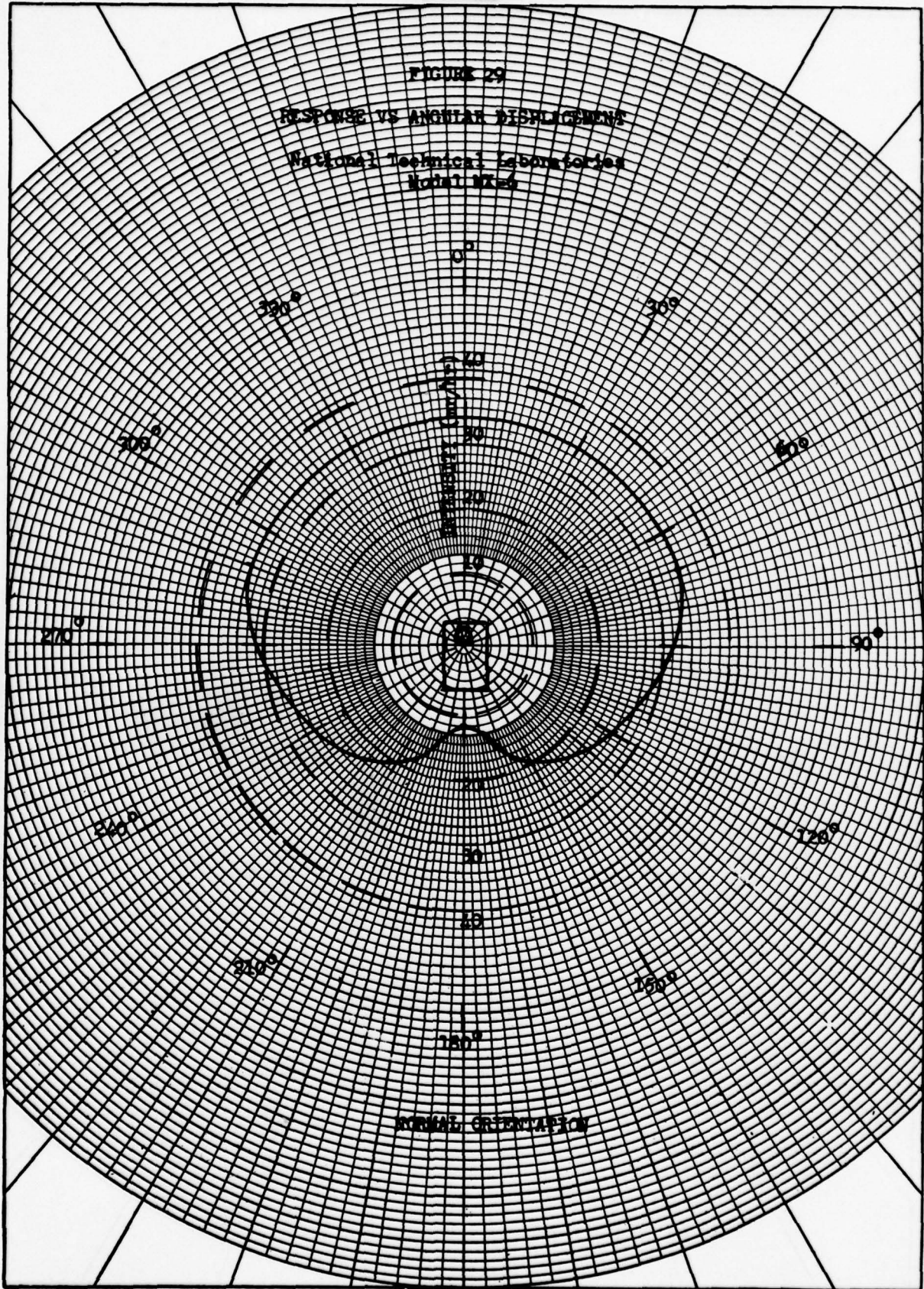

~~RESTRICTED~~

UNCLASSIFIED

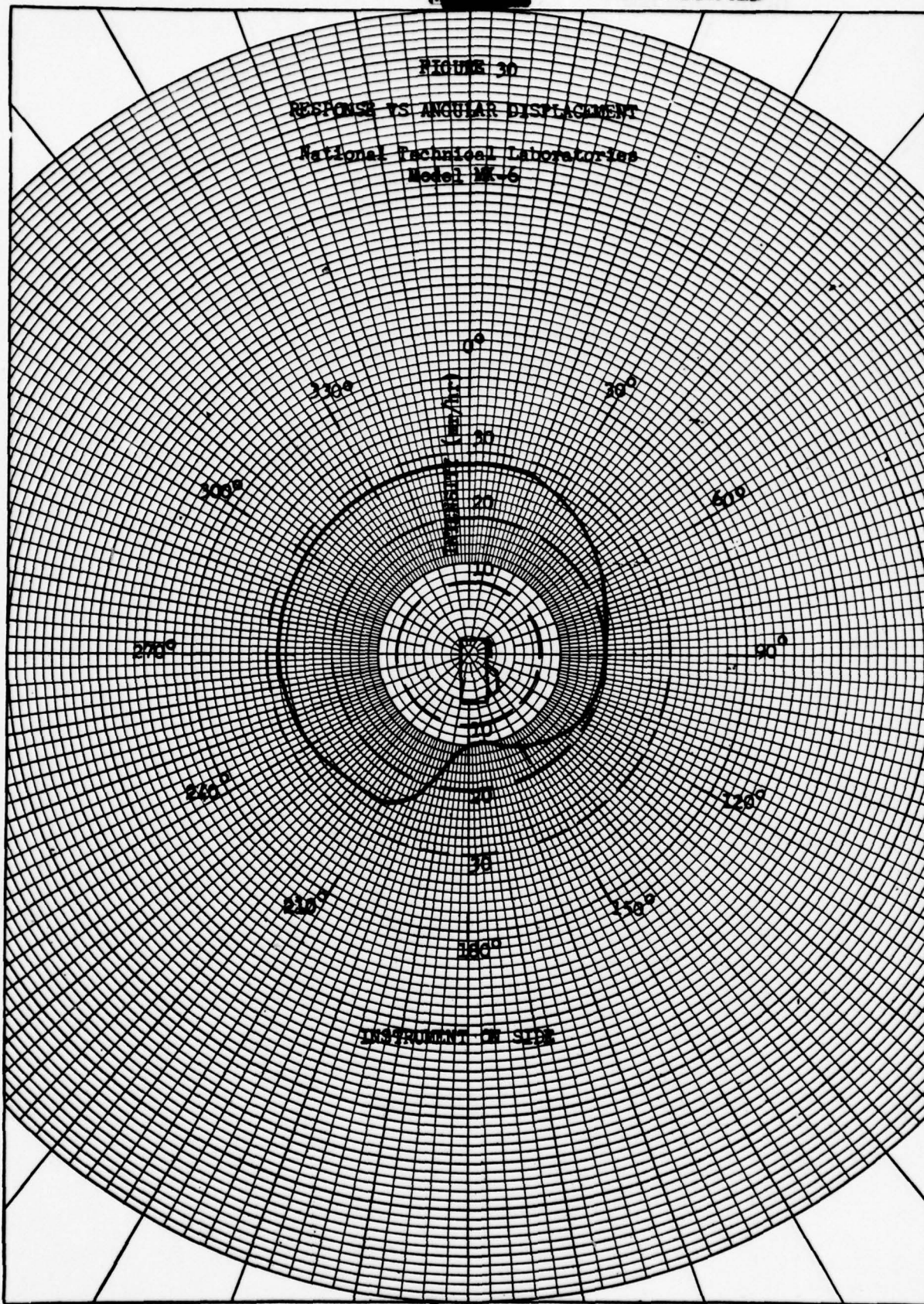

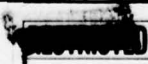
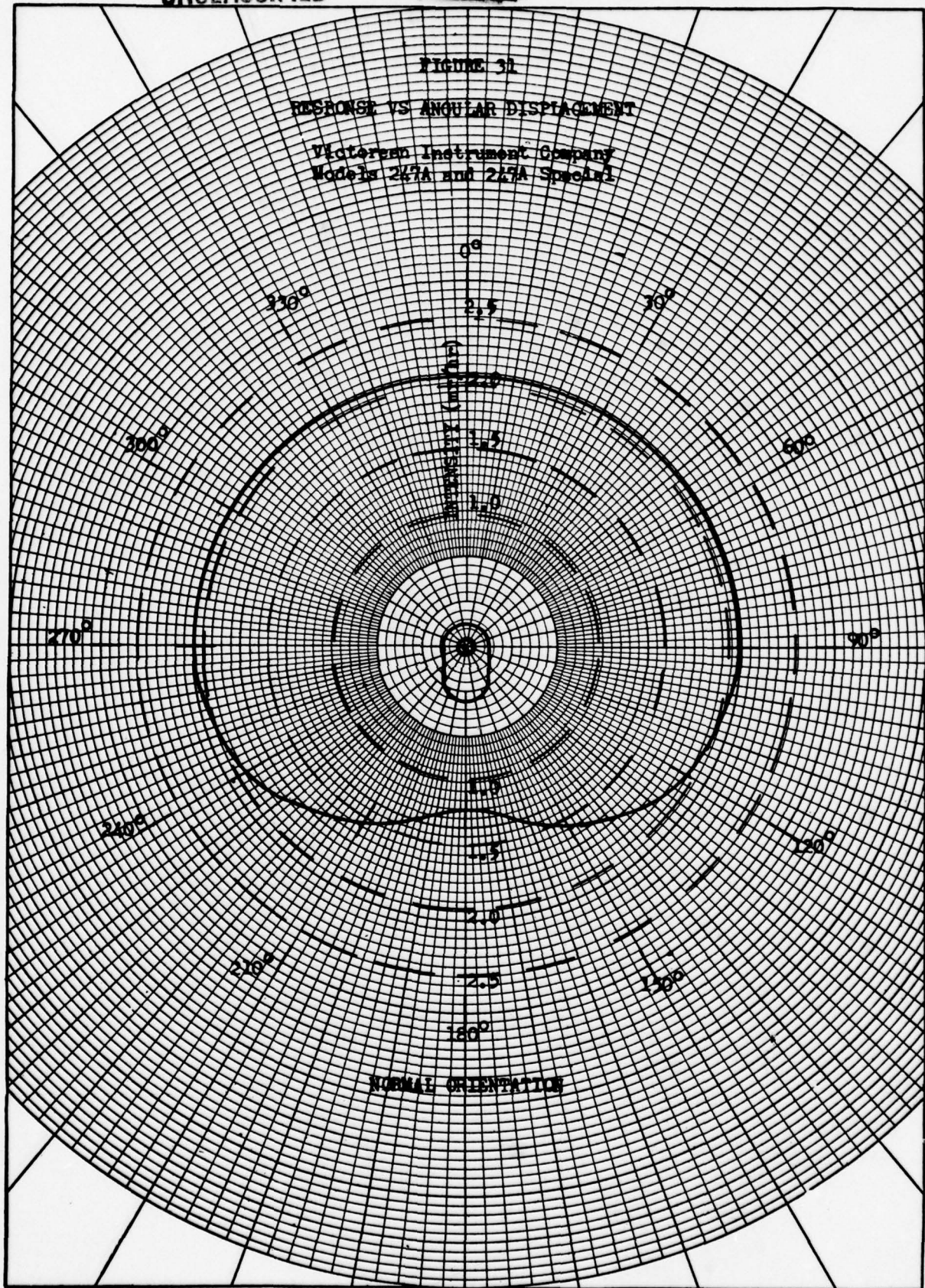
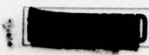

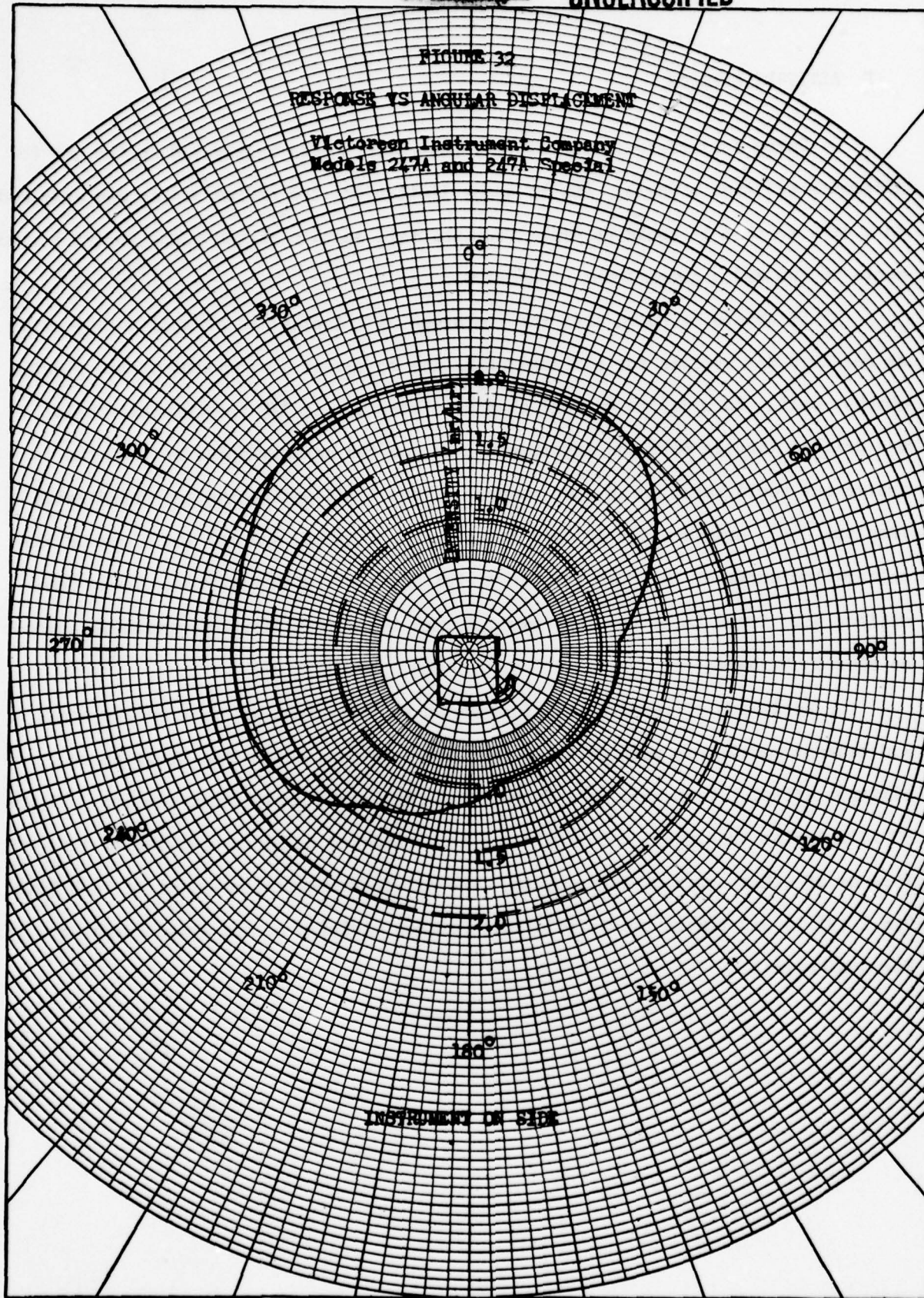



D ALTITUDE EFFECTS

Using a standard radium source, instruments were calibrated in the air to determine altitude effects. Due to space limitation, the radium source was attached to a wire so that it could be drawn from the tail section of the plane toward instruments in the radio compartment of a B-17G.

It should be noted that the Victoreen 247A ionization chamber survey meter as received was useless for air monitoring due to severe distortions of the plastic chamber wall. In order to prevent chamber distortion, a 1/8 inch diameter hole was drilled through both the instrument case and the chamber cover so that the instrument would react as an open chamber. This modification had two undesirable results: (a) moisture was allowed to enter the chamber, and (b) the slope of the calibration curve of the open chamber varied inversely with altitude. These conditions were found to be far less serious than those resulting from pressure changes on closed chambers.

Variation of results from instrument to instrument within a single model and between models was such as to produce only the conclusion that there is an altitude effect. Much more data is required for intelligent interpretation. Figure 33 illustrates this point but should not be considered as representative of this type or of other types of instruments. The Air Instrumentation Report of Task Unit 7.6.1 (3) is on file in the Radiological Defense Division of the Armed Forces Special Weapons Project.

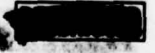
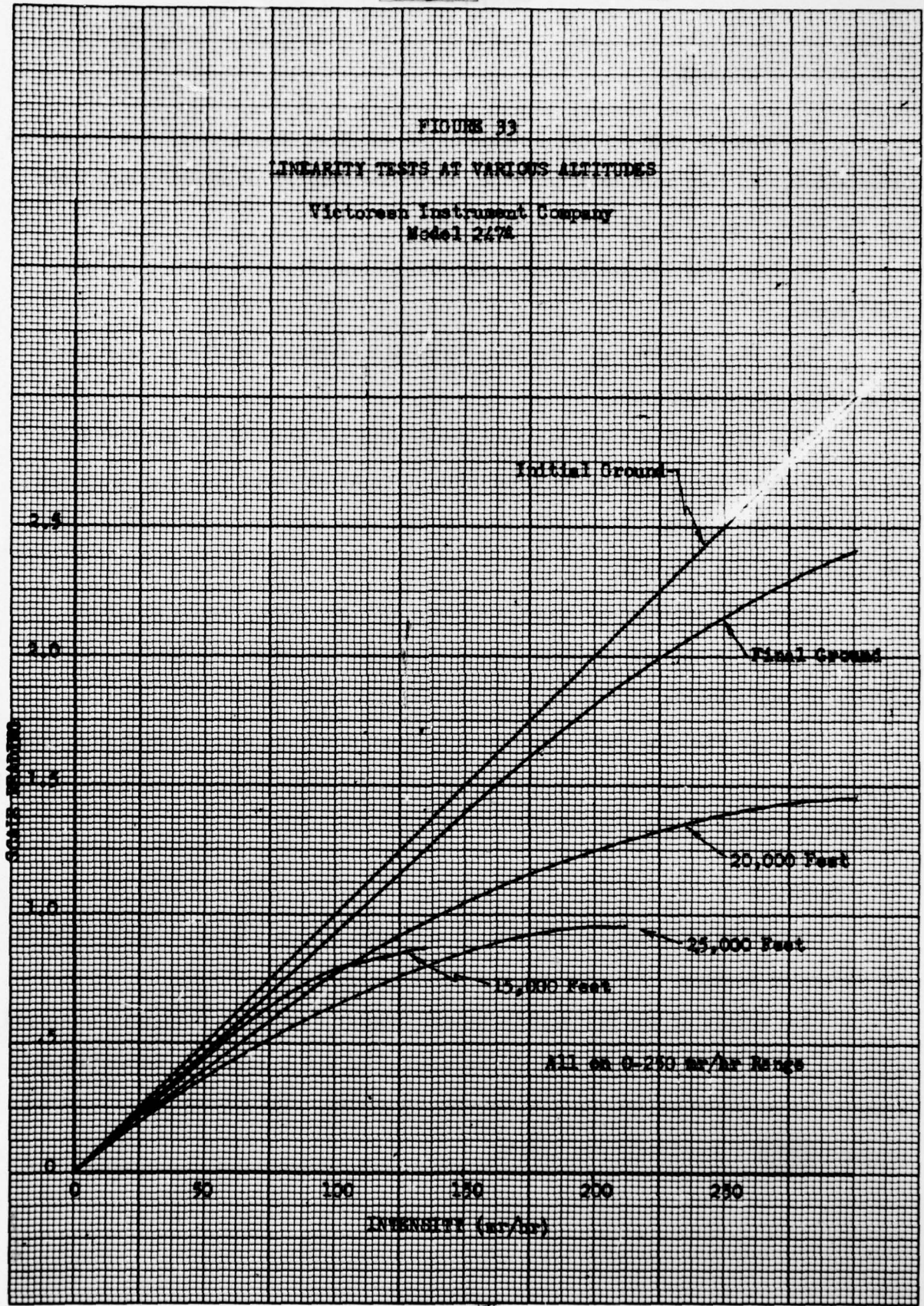

FIGURE 53
LINEARITY TESTS AT VARIOUS ALTITUDES
Victoreen Instrument Company
Model 247A



E SHOCK RESISTANCE

Instruments were dropped a distance of one foot onto a steel deck in normal orientation. If they were then operable, they were dropped in other orientations and the height raised until failure occurred.

On Type 263A the indicating meter broke loose from its housing on the first drop.

Type MX-5 survived all one-foot drops with variable shifts of zero and sensitivity after each drop.

Type 2610 survived all one-foot drops with not over 10 per cent of full scale zero shift and no change in sensitivity. Two-foot drops in normal position sprung the probe clamps. A two-foot drop on the side bent the meter needle, but the instrument was operable.

Type 247A survived all one-foot drops with not more than 10 per cent change in zero. A one and one-half foot drop on the top broke the handle, but the instrument was operable.

On Type MX-6 the shock tests were not satisfactory, because each drop shook loose the battery contacts. When the contacts were fixed, the instrument was operable after all one-foot drops.

F IMMERSION

Only three survey instruments and one model of the dosimeter were suitable for immersion testing. The others had obvious leaks.

Two meters of the National Technical Laboratories Model MX-5 were submerged with the top about three inches below the surface of sea water. One meter failed after 30 minutes and was restored to service by drying. The second meter operated properly and was completely dry inside.

UNCLASSIFIED

The Victoreen Instrument Company Model 247A was submerged in sea water and floated upside-down with about three inches of the bottom protruding. After 30 minutes of immersion the instrument functioned properly and was completely dry inside.

The National Technical Laboratories Model MX-6 was submerged with the top about three inches below the surface of sea water. There was no failure, and the instrument remained dry inside.

Six of the A. O. Beckman 200 mr dosimeters were immersed about six inches below the surface of sea water. After two hours two had leaked and failed; after four hours three had leaked and failed; after eight hours four had leaked and failed; after 10 hours five had leaked and failed; and after 40 hours five had leaked and failed. One instrument was tight and serviceable at the end of the test.

G TILT FROM VERTICAL

In determining the tilt from the vertical required to tip over the instrument, the instrument was placed in a normal operating position and then tilted from the normal position to such an angle that the instrument tipped over on its side. This gave an indication of the stability of the instrument when standing on the deck of a ship or boat or on the bed of a truck. Results of this test are given in Tables I and II.

H METERING TIME CONSTANT

The metering time constant (RC) was determined by introducing approximately a full-scale meter reading and then measuring the amount of time required for the meter to drop to approximately one-third of its value when the radiation source was removed from the detector. The time constant was also studied as the time required to reach two-thirds of its final average reading when a radiation source was moved

UNCLASSIFIED

UNCLASSIFIED

from a distance to a set point near the detector. The value given in Tables I and II is the average of the two observations.

I MICROPHONICS

The observations on instrument microphonics were made by allowing the instruments to drop from one to two inches onto a hard surface and then noting the effects on meter readings. An examination was also made as to the response of the instrument to sharp raps on the side of the case. Observations are tabulated in Tables I and II.

J MISCELLANEOUS TESTS ON SURVEY INSTRUMENTS

Zero fluctuations per second and zero drift per hour were determined by observations made over approximately 40 hours of continuous operation immediately following installation of new batteries.

The temperature, light, and wind sensitivities were studied only on the basis of routine operation.

Air pressure sensitivity is based on comments made by personnel involved in air operations and does not represent the results of any formal study.

The warm-up period was determined as the time required for the instrument to stabilize to a point that the zero drift was less than one per cent of full scale per minute.

K TESTS ON POCKET DOSIMETERS

Table III lists characteristics of the pocket electroscopes used for determining individual dosages of gamma radiation. Certain observations have been made

~~RESTRICTED~~

UNCLASSIFIED

which are obvious from their listing in the tables. The methods followed in conducting other tests are described below.

Comments on ruggedness were made on the basis of tests conducted at manufacturers' plants prior to shipment to Operation Sandstone. The ruggedness tests constituted a drop and spin test. The dosimeters were allowed to drop five times through three feet so that the dosimeter fell a minimum of once on each end and once on the side. The spin test consisted of rapidly rotating the instrument between the palms of the operator's hands. An observation was then made as to whether any units of the assembly were moved from normal positions by these accelerating forces.

The dosimeter calibration correction factor was determined by calibrating 40 or more instruments by means of gamma rays from a radium source. After obtaining the average calibration curve of the instruments, a determination was made as to the average deviation from the calculated reading.

During Test Zebra, 50-r dosimeters and film badges were exposed to flash radiation. Dosimeters and film badges were located at stations at various distances from the detonation. These instruments were placed in position on Z minus one morning and recovered at approximately Z plus six hours. The results of these exposures are tabulated in Table IV. Further information on the film badges may be found elsewhere (4).

It will be noted from the data in Table IV that with a few exceptions the dosimeters read 10 per cent lower than the film badges. Since this is fairly uniform throughout the various stations, it can be concluded that the difference between the film badge and dosimeter is a matter of spectral response. Much more significant is the fact that the dosimeters do not saturate at high flash intensities.

The leakage history of the dosimeters is such that one would immediately suspect that factor to be responsible for the one high reading at Station "E" and the reading for Station "F".

UNCLASSIFIED

TABLE IV

FLASH EXPOSURES OF KELLEY-KOETT MODEL K-160 (50 r FULL SCALE)

GAMMA DOSIMETERS AND FILM BADGES

STATION	DOSIMETER READING (r)	FILM BADGE READING (r)
A	40	50
	45	50
		50
		51
B	27	31
	30	31
		34
		34
C	15	17
		19
		19
D	7	8.6
		10.5
		10.5
E	28	6.5
	6	6.5
		6.0
		6.5
F	5	4.5
		4.3
		4.3
		4.5
G	near zero	2.0
	near zero	2.1
		2.2
		1.9

UNCLASSIFIED

UNCLASSIFIED

VII CONCLUSIONS AND RECOMMENDATIONS

On the whole the instruments used for health protection at Operation Sandstone were substantial improvements over those used at Bikini during Operation Crossroads. Once the obvious design faults were corrected, all meters performed well and required only moderate servicing. Several improvements in design can be made in every case to make the instruments more serviceable for field tests. The most serious defects occurred in the pocket dosimeter. This is a most useful instrument and is essential to operations of this type. Only by intensive drying by silica gel between issues was it possible to keep a sufficient quantity in working order to meet the requirements of the operation. Future designs must be made completely waterproof.

Any further operation of a similar nature should be equipped with a greater number of ionization chamber instruments, and some of these instruments should be capable of reading 50,000 mr/hr. Geiger-Mueller counters were available in sufficient quantity to meet all requests with a good reserve to meet any failures. On several occasions every ionization chamber instrument was issued, and some program adjustments were necessary to meet all requests.

None of the survey instruments tested were completely satisfactory for air use except when placed in constant pressure--constant temperature chambers. further study on instruments for use during air monitoring is necessary.

A questionnaire submitted to the working monitors produced little in the way of constructive suggestions. All wanted a smaller and lighter instrument, and there is no doubt that these are desirable characteristics. It is also certain, however, that ruggedness and dependability must not be sacrificed for compactness. Most monitors agreed that the protective covers designed to prevent instrument

UNCLASSIFIED

~~RESTRICTED~~

contamination were clumsy and interfered with proper manipulations of the controls. There was a universal feeling on the part of the monitors that an illuminated meter scale would be highly desirable. This was true even in an operation conducted primarily in the open. It would, of course, be more desirable when monitoring the interior of ships or structures in an operation such as Operation Crossroads.

In general, the instruments used during Operation Sandstone were satisfactory from a circuit standpoint or could be readily made so. Radical changes do not appear necessary. More rugged construction based on JAN specifications and changes in mechanical design should produce very satisfactory instruments for field use.

It should be noted that the monitors operating instruments were of higher caliber than those who will generally operate them with military field units. In addition, the operation was of relatively short duration and had continued high level maintenance emphasis. As a result, the reader should be cautioned not to anticipate equal instrument abuse during future operations.

VIII REFERENCES

- (1) "Results of Field Tests on Radiation Detection Instruments," Adrian H. Dahl, 30 June 1948.
- (2) Task Group 7.6 letter to the Chief of the Bureau of Ships, "Experimental Radisc Instruments, Report on," dated 5 May 1948.
- (3) Instrumentation Annex 8 to 7.6.1 Operational Report, dated 1 July 1948.
- (4) "Gamma Radiation versus Distance," Project 7.1-17/RS-1 by Herbert Scoville, Jr., CDR E. J. Hoffman, USN, and LT E. C. Vicars, USN, dated 30 June 1948.

~~RESTRICTED~~

UNCLASSIFIED

UNCLASSIFIED

APPENDIX A

TO: Colonel James P. Cooney

FROM: (Dr. R. E. Lapp
(CDR H. L. Andrews
(LCDR D. C. Campbell

SUBJECT: Final Report of the Subcommittee on Radsafe Survey Instruments

ENCLOSURE: Re Final Report

1. At its first meeting on 18 September 1947, the Radsafe II Committee authorized the formation of a subcommittee on instruments for the purpose of determining the types of radiological instruments that might be procured. CDR Andrews (NIN), LCDR Campbell (AFSWP), and Dr. R. F. Lapp (JEDB) were appointed to the subcommittee and were directed to submit an interim report as soon as possible, preferably within a week.
2. The Subcommittee held its first meeting on 20 September 1947. As a result of this meeting, the Subcommittee issued an interim report dated 22 September 1947. It was decided that insufficient up-to-date information was available on which to base conclusions in the interim report and that a committee survey of the current development work in the Boston, Cleveland and Chicago Areas was in order.
3. Between 23 and 27 September 1947, Dr. Lapp and LCDR Campbell visited Boston, Cleveland, and Chicago and made a quick survey of the Radsafe instrument sites^{and available} tion, both with respect to instruments immediately available/within one year. Campbell and Lapp also made a visit to one company in Arlington, Virginia, on 1 October 1947. Andrews visited Philadelphia, Pa. on 27 September 1947.
4. In addition to visiting instrument companies in the eastern U. S. areas, the Subcommittee has contacted companies in other parts of the country to determine

UNCLASSIFIED

UNCLASSIFIED

SECRET

the status of their development work in the field of survey instrumentation. Contact has been made with interested agencies of the Army, Navy and Air Force as well as the Atomic Energy Commission to determine what work of related nature is being pursued by these agencies.

5. A final meeting of the Subcommittee was held 4 October 1947, and the Final Report, Enclosure A, which covers immediate requirements, was prepared. Longer developments will be reported separately.

/s/R. E. Lapp
R. E. LAPP
for the Subcommittee

Encl. A - Final Report

cc: CDR H. L. Andrews
Dr. R. E. Lapp
LCDR D. C. Campbell (3)
CAPT F. I. Winant, Jr. (2)
Major Dauer
Col. Cooney (3)

SECRET

UNCLASSIFIED

FINAL REPORT ON RADSAFE SURVEY INSTRUMENTS

1. Purpose of the Report

The purpose of this report is to provide a schedule for instrument procurement, itemized by manufacturer and type which may be obtained in the quantities noted in Paragraph 2 prior to 15 January 1948. Some slight modifications have been made to the total quantities of general catalogues of instruments which were determined by the Radsafe II Committee at its first meeting on 18 September 1947 and contained in the interim report of 27 September 1947.

2. Findings of the Committee

In order to arrive at its findings, the Subcommittee considered the companies listed in Attachment I in order to make the following schedule.

A. Geiger-Mueller Survey Instruments

	Model	Price	Quantity
a- Instrument Development Labs.	2610	\$250	25
b- Victoreen Instrument Co.	263A	200	100*
c- National Technical Labs.	MX-5	200	25
		<u>\$31,250</u>	<u>150</u>

*May be obtained from 300 to be delivered to the AEC by 15 November 1947.

B. Ion Chamber Survey Instruments

a- National Technical Labs.	MX-2	\$300	20
b- Victoreen Instrument Co.	247A	250	90
c- Victoreen Instrument Co.	Mod. 247A*	250	10
d- Reuland Co.	Zeus 2100*	275	20
		<u>\$26,500</u>	<u>100</u>

*See Paragraph 5 below.

Encl. A

C. Direct Reading Dosimeters (Pocket Electroscopes)

	Model	Price	Quantity
a- Landsverk Electrometer Co.	L-200	\$43.20	300
b- Landsverk Electrometer Co.	L-10r	50.00*	50
c- Landsverk Electrometer Co.	L-50r	75.00*	10
d- Instrument Development Lab.	3360	30.50	200**
e- National Technical Labs.		35.00*	100
		<u>\$25,810*</u>	<u>660</u>
f- Landsverk Charging Boxes		\$35.00	36
g- IDL Charging Boxes	3360	35.00	20
h- National Technical Lab. Charging Boxes		35.00	10
		<u>\$2310.00</u>	<u>66</u>

*Estimated price.
 **250 may be obtained from the Atomic Energy Commission from an order to be delivered approximately 1 January 1948.

D. Direct Reading Dosimeters (Vacuum Tube Integration)

	Model	Price	Quantity
a- Victoreen Instrument Co. Proteximeter		\$175	25
		<u>\$4,375</u>	<u>25</u>

3. While the Subcommittee did not have sufficient time to draw up a complete set of specifications for any of the subject meters, only the above noted meters approached acceptance under the following broad considerations:

- a- Portability (weight not over 12 pounds; size 4x10x10 inches; carrying device; etc).
- b- Characteristics of the sensitive element (G-M tube, range 0-0.1, 0-1, 0-10 r/day; or ion chamber ranges; 0-1, 0-10, 0-100, 0-1000 r/day).
- c- Ruggedness (shock, vibration test)
- d- Contaminability (disposable cover, smooth finish, not painted)

UNCLASSIFIED

- e- Temperature effect on sensitive element and components (range 32-135° F and lower if possible).
- f- Battery life (120 hr. at 8 hr./day minimum).
- g- Tropicalization.
- h- Humidity effect.
- i- Circuit stability.
- j- Water proofing, immersion proofing, etc.
- k- Time of response (less than 10 seconds).
- l- Accessibility for repair (easy battery replacement).
- m- Calibration-reliability.
- n- Ease of adjustment (dial set, zero set, range change).
- o- Photosensitivity.
- p- Altitude effect (sealed ion chamber).
- q- Quality of components (procurability and standardization).

4. Possible Procurement Difficulties

As anticipated in the preliminary survey, the only serious bottleneck is with the Landsverk Electrometers. At the time of the Subcommittee visit, Dr. O. G. Landsverk was on the verge of making a decision either to expand into a new plant in West Chicago and retain his own facilities, or to join with some other company. If he continues with his own business, it is possible that 500 L-7 Meters can be obtained, from parts on hand, by 15 January. On the other hand, there is no promise of delivery on O-20-r or higher range meters, and Landsverk would want a development or cost plus contract to do this work. Immediate action is needed to prevent this item from becoming a bottleneck. It is the Committee's recommendation that an order less than 500 of the L-7 Meters be ordered, so that Landsverk may devote his time to the higher range meters.

UNCLASSIFIED

UNCLASSIFIED

Delivery of the National Technical Laboratory electrometers by January 15 may not be possible, but an order is recommended to stimulate production sources more reliable than those of Landsverk.

5. Instrument Modifications

The Victoreen 247A ion chamber meter has four scale ranges: 2.5 mr/hr full scale, 1x, 10x, 100x, and 1000x. It is desired to obtain ten instruments modified to have four scale ranges: 2.5 mr/hr full scale, 10x, 100x, 1000x, and 10,000x. Thus, the Company has agreed to do without additional cost.

The Rauland Corp. Zeus is a portable alpha, beta, gamma meter, and it is the Subcommittee's recommendation that this instrument be modified to gamma reading only. It is further recommended that the instrument be placed in a metal case. These modifications, especially removal of the alpha-beta feature, should simplify the instrument and perhaps effect a reduction in price.

6. Additional Survey Instruments for Aircraft

The quantities of survey instruments listed under Paragraph 2 do not include allowance for more than six manned aircraft. Should more aircraft be involved, it is recommended that the following quantities and types of instruments be procured for each aircraft:

- 1- Ionization Chamber Survey Meter
- 2- Geiger-Mueller Survey Meter
- 1- Proteximeter or equivalent

7. Alpha Measuring Survey Instruments

It is the Committee's recommendation that 40 alpha measuring instruments be procured. Twenty (unmodified) Rauland Zeus, in addition to those mentioned in

~~CONFIDENTIAL~~
UNCLASSIFIED

Paragraphs 2 and 5, and that 20 AEC design Pluto Meters, Model 356, be obtained from a lot of 125 manufactured by the Victoreen Company and delivered approximately July 1947 to the Atomic Energy Commission.

8. Engineering and Production of Existing AEC Survey Instruments

It is known that there are in existence at the various sites of the Atomic Energy Commission survey instruments which are more satisfactory than those listed under Paragraph 2 above. For example, Los Alamos has developed the Watts meter and Sandia has a modification of his meter, but to date this has not been engineered or produced by any company. It is not believed that these meters can be engineered and placed in production in order to meet the present needs.

9. Additional Laboratory Instruments

It should be noted that this report covers survey instruments and does not include any instruments required for laboratory purposes.

/s/R. F. Lapp
R. E. LAPP
for the Subcommittee

Attachment I:
List of Radiological Instrument Companies

~~CONFIDENTIAL~~
UNCLASSIFIED

ATTACHMENT I

LIST OF COMPANIES WHOSE PRODUCTS WERE CONSIDERED IN INTERIM REPORT.

Applied Physics Corp.	40 S. Oak Knoll	Pasadena, Cal.
Atomic Instrument Co.	160 Charles St.	Boston, Mass.
Berkeley Scientific Co.	601 Nevin Ave.	Richmond, Cal.
Cambridge Instrument Co.	Grand Central Station	New York, N. Y.
Cyclotron Specialties		Moraga, California
Dormitzer Elect. & Mfg. Co.	782 Commonwealth Ave.	Cambridge, Mass.
Alan B. duMont Labs.		Pasenic, N.J.
Edgerton, Germeshausen & Grier	77 Mass. Ave.	Cambridge, Mass.
Electronics Control Corp.	1573 E. Forest Ave.	Detroit, Mich.
General Radio Co.	275 Mass. Ave.	Cambridge, Mass.
Geophysical Instrument Co.	1820 N. Nash St.	Arlington, Va.
Henson Co., Fred		Pasadena, Cal.
Herbach and Rademan Co.	517 Ludlow St.	Philadelphia, Pa.
Instrument Development Labs	223 W. Erie St.	Chicago, Ill.
Kelley-Koett Mfg. Co.		Covington, Ky.
Landsverk Electrometer Co.	6030 Ellis Ave.	Chicago, Ill.
MacLeod and Hanopol	10 Joiner St.	Charleston, Mass.
National Technical Labs.	814 Mission St.	S. Pasadena, Cal.
North American Phillips Co.	100 E. 42nd St.	New York 17, N.Y.
Radiation Counter Labs.	1844 W. 21st St.	Chicago, Ill.
Rauland Corp.	4245 N. Knox	Chicago, Ill.
Raytheon Mfg. Co.	160 State St.	Boston, Mass.
Sylvania Electric Prod. Co.	70 Forsythe St.	Boston, Mass.

UNCLASSIFIED

Technical Associates, Inc.	3736 San Fernando Rd.	Glendale, Cal.
Tracerlab, Inc.	55 Oliver St.	Boston, Mass.
Victoreen Instrument Co.	5806 Hough Ave.	Cleveland, Ohio

The following additional companies are listed for future references:

Bendix Aviation Corp.	Special Products Div. Fisher Bldg.	Detroit, Mich.
Consolidated Engineering		Pasadena, Cal.
Cornell Engineering		Buffalo, N. Y.
Gillilan Radio		Los Angeles, Cal.
Hewlett Packard Co.		Palo Alto, Cal.

UNCLASSIFIED

UNCLASSIFIED

APPENDIX B

PHOTOGRAPHIC FILM LABORATORY

The photographic film laboratory for processing film badges was housed in the regular photographic laboratory of the U.S.S. Bairoko. This space of about 600 sq. ft. was air conditioned, and the processing tanks were installed in temperature controlled baths. Personnel consisted of part-time assistance by Major J. T. Brennan (MC) USA, and the following photographers mates: Fletcher, James S., AF 3; Liebe, Ernest B., PH 3; Rhenish, Edward J., AF 3; and Varnum, James E., AFAN.

All processing was done with packaged developers to avoid the errors inherent in weighing and mixing. Calibrations were made with the standard radium sources used by the instrument laboratory. Two Weston Electrical Instrument Company photographic densitometers were used for measuring the processed film. These densitometers were preproduction models built to AEC specifications. They differed from production models in the design of the case.

The operation of the film laboratory was uneventful, but a few comments may be of help in future operations. In an operation of this sort the film badge load has very high peaks, and a short processing and reading time is essential. The personnel assigned to this job were not adequate to handle the peak loads. On occasions they were required to work as much as 36 hours without relief. This was done willingly, but under these extended working periods, errors are very apt to occur. In a future operation of comparable magnitude, six men should be assigned, and one of these should be a chief petty officer.

The routine film badges had two films with maximum ranges of 1.5 and 10 r respectively. It is felt that in future operations the routine badge should contain

UNCLASSIFIED

~~SECRET~~

UNCLASSIFIED

a third film sensitive to perhaps 100 r. This will rarely be needed, but on a few occasions at Eniwetok this third film could have been used to advantage.

Considerable time was consumed in the laboratory in marking the films before processing. This was done by pencil on the films. The greatest care must be taken to avoid errors in identification, and this point should be carefully studied before another operation. Undoubtedly better methods can be devised.

~~SECRET~~

UNCLASSIFIED

TABLE OF CONTENTS

	Page
I ABSTRACT.	1
II OBJECTIVE.	1
III HISTORICAL	1
IV EXPERIMENTAL	2
V CONCLUSIONS AND RECOMMENDATIONS.	5
TABLE 1 - Exposure Tests X-ray and Yoke	
TABLE 2 - Exposure Test Zebra	

CRYSTAL DOSIMETERS

I ABSTRACT

A variety of crystals and Vycor glasses, which indicated the amount of radiation to which they had been exposed by their degree of coloration or color changes, were exposed at several levels of gamma radiation. Coloration varied from that which was barely perceptible visually, to a very pronounced and deep rich hue. A preliminary estimate of results obtained indicate that this method of radiation exposure measurement shows promise of practical application and merits considerable attention to effects its perfection. Current problems presented by the use of untreated crystals are: (a) crystal coloration lacks stability and is affected by time and exposure to light; (b) visible color changes occur within a range of exposures which is above the lethal dosage for personnel and hence has no value as an indicating device in effecting radiological safety for human beings.

II OBJECTIVE

The object of this project was to field test various crystals for use as dosimeters to determine by visual observation of color changes the radiation exposures in the lethal and sub-lethal range and to determine the degree of exposure to gamma radiation of various biological samples.

III HISTORICAL

One of the prospective problems in radiological defense after an atomic bomb attack will be to determine rapidly and with a fair degree of accuracy, the extent of radiation exposure of personnel. This knowledge

UNCLASSIFIED

will permit the most efficient use of medical supplies and talent during recovery operations. It is possible that when efficacious medical treatment is developed the treatment may depend upon the extent of exposure.

The requirements for an indicating device to measure this exposure, are that it be light, easily carried, relatively inexpensive, operate under field conditions, and be capable of being read by relatively inexperienced personnel with little or no auxiliary equipment. Such contradictory specifications are not fulfilled by any devices now in use.

The coloration of various crystals and glasses by x-rays has been known for a number of years. Some preliminary work was carried out on several glasses by the Naval Research Laboratory for the Naval Medical Research Institute prior to operation CROSSROADS. Vycor glasses seemed to be the most practical of those used to determine the dosage received by animals exposed at Bikini. Because of the small dosage received by these animals, completely satisfactory results were not obtained. These glasses have since been investigated further by the Naval Medical Research Institute and calibrated. At present they are read by means of a photoelectric densitometer. Naval Research Laboratory continued work on several other crystals, particularly sodium chloride and lithium fluoride and Naval Medical Research Institute has conducted some preliminary studies on activation of potassium bromide to increase its sensitivity. A report on these materials will be given at a later date of this report.

IV EXPERIMENTAL

The following crystals were exposed:

28 Lithium Fluoride.
18 Sodium chloride.

UNCLASSIFIED

- 6 Potassium bromide.
- 10 Potassium chloride.
- 56 Vycor glass rods.
- 5 Sodium chloride and Manganese chloride.
- 3 Sodium chloride and Silver chloride.
- 15 Potassium Bromide activated.

In addition, the following materials were packaged in transparent capsules in a powdered or granulated form and were also exposed.

- 8 Zn_2SiO_4
- 4 Zn Ba SiO_4
- 2 Zn GeO_4
- 5 NaCl
- 3 KCl
- 3 ZnS
- 2 Silver phosphorous glass.

The crystals were artificially grown and most of them were not polished sufficiently high to obtain the best optical effect. They are quite uniform in size being $1" \pm 1/16"$ long and $1/2" \pm 1/16"$ square and were all colorless and transparent prior to exposure. Two crystals were placed in a $1/8"$ thick aluminum tube with a screw cap seal for field exposure. The capsules were similarly mounted except that they were packaged three to a tube. The Vycor glass rods, optically polished, $3/8"$ in diameter and 3" long, were packaged in corked aluminum tubes. The activated crystals were $3/8"$ cubes. These were imbedded in a clear plastic circular disc about $1\frac{1}{2}"$ in diameter and $5/8"$ thick.

Approximate calibration colors for the more abundant crystals were prepared by NRL and forwarded to the test area but they were never received. In lieu thereof, an attempt was made to calibrate standards aboard ship by exposing some crystals to a 250 mg radium source but this

UNCLASSIFIED

met with little success. Very light coloration was secured at exposures of 100 r to 500 r. With direct comparison it would have been very difficult to determine the gradations of exposure. The lightness of color has since been determined to have been due to the rapid fading that takes place within the first few hours after coloration. With the radium source it was not practicable to secure a rate of uniform exposure of much greater than 20 r per hour. The Vycor glass dosimeters were individually calibrated by exposure to known quantities of x-rays at the Naval Medical Research Institute. Their coloration is determined with an accuracy of 1% by photoelectric means.

Although it was not possible to secure a satisfactory calibration it was desired to test the crystals for uniformity and reproduceability against the mixture of gamma rays and neutrons produced by the bomb. On test A-ray one of each of the several types was mounted at 1400 yards and at 800 yards from point zero to obtain a check on their reaction. The crystals, except for the lithium fluoride, appeared to be saturated in color at the closer distance and to have just begun to show coloration at the 1400 yard station. The crystals were recovered and examined at about plus thirty-six hours. At the second test the crystals were exposed and a large number recovered at about plus eight hours. It was desired to obtain a permanent record of their color changes so an attempt was made to photograph them in color. During the short interval of several minutes that was required to arrange them in the sunlight many faded completely. It was therefore decided to bleach all the remaining crystals out by prolonged exposure to sunlight and re-expose them on the third test. After recovery, accomplished at about eight hours, they were briefly examined

UNCLASSIFIED

and compared visually then sealed in their tubes for return to the Naval Research Laboratory and precise examination.*

The Vycor glass and activated crystals were returned to the Naval Medical Research Institute for reading of the dosage received. Visible color changes were noted.*

Table 1 lists the distances at which crystals were exposed in Test X-ray and Yoke and recovered with a description of the color change. In Table 2 the location for the Test Zebra samples are listed.

V CONCLUSIONS AND RECOMMENDATIONS

Artificial crystals offer a promising method of determining degrees of exposure with what should be a fair degree of accuracy. Although the results indicated in Table 1 are shown roughly, within each category of color intensity a gradation could be discerned and the grouping was purely arbitrary. When several crystals of the same material were exposed at the same distance no visible color difference was noted. At the times of recovery sodium chloride appeared to be the most sensitive and lithium fluoride the least. Lithium fluoride seemed to attain the most permanent color, the remaining crystals fading completely in a few minutes upon exposure to sunlight.

Continued investigation at the Naval Research Laboratory has improved the sensitivity and permanency of several of the crystals employed on these tests and they will be reported upon in the near future. When these are developed to a practicable stage they should be tested in the field in a systematic manner.

* When analysis of the results are obtained a supplementary report will be submitted.

UNCLASSIFIED

The following recommendations are made: (a) The sensitivity of the crystals should be increased so that the one half maximum color density exposure should occur at about the beginning of the lethal range. (b) The crystals should be coated with a clear plastic to prevent sensitivity to moisture. (c) Calibration of the crystals to fast and slow neutrons should be accomplished. (d) At future tests only the most promising types of crystals upon which complete calibrations are furnished should be exposed. (e) The degree of color permanence should be as great as practicable to achieve. (f) The crystal should be highly polished to obtain the best optical surface possible with the material used.

UNCLASSIFIED

EXPOSURE TESTS X-RAY AND YOKE

TABLE 1

Material and Characteristic color	Test and Distance (Yards)	Color Intensity	Gamma Exposure (r)	
LiF	Yellow	Y-600, Y-700	medium	25,000-100,000
		Y-500		
		Y-1000, Y-900	light	5,000-15,000
		X-800		
	Y-1100, Y-1250, Y-1300	very light	1,000-3,000	
NaCl	Amber	Y-1400, X-1400	none visible	800
		X-800, Y-1000	very deep	3,000-5,000
		Y-1100		
		Y-1250, Y-1400	deep	800-1,300
	Y-1400	light	800	
KCl	Blue	X-800, Y-900, Y-1000	very deep	4,000-9,000
		Y-1100, Y-1250	deep	1,300-3,000
		Y-1250, Y-1300	medium	1,000-1,300
KBr	Purple	X-800, Y-1000	very deep	4,000-5,000
		Y-1100, Y-1250, Y-1400	deep	800-3,000

EXPOSURE TEST ZEBRA

TABLE 2

Distance (Yds)	LiF	Number and Material		
		NaCl	KBr	KCl
400	4			
500	4			
600	2			
700	2			
800	2	1		
900	1	1	1	1
1000		2	1	1
1100		2	1	1
1200		2	1	1
1300		2	1	1
1400		2	1	1
1500		2		1
1600		2		1

The remainder of the crystals were not recovered or were damaged on previous tests. Coloration charts and color decay curves will be forwarded in a supplementary report.

~~SECRET~~
UNCLASSIFIED

REPORT ON NAVY RADIAC METERS

Lt. N. F. Murphy, USN

-1-

~~SECRET~~

UNCLASSIFIED

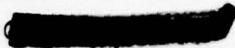

REPORT ON NAVY RADIAC METERS

Introductory Remarks -

The Navy Models AN/PDR-1(XN-1), AN/PDR-8 (X) and AN/PDR-11(X) Radiac Sets represent the first of their class to be designed by or for a branch of the military service for radiological survey purposes in the field. As such, each has embodied some radical departures from similar instruments which were designed purely for commercial or research work in the laboratory.

Parts I through VI of this report consist of all technical data obtained to date on subject meters as well as the general concensus of opinion on same by personnel who have had the opportunity to use or observe one or more of the original experimental models shipped for test and evaluation purposes to Project Sandstone.

* * * * *
* * * * *
* * * * *

INDEX

Part I Model PDR-1 Portable Beta-Gamma Survey Meter

1. Case and Physical features
2. Probe and probe housing
3. Indicator
 - (a) Microammeter
 - (b) Audio output and headphones
4. Electrometer circuit
 - (a) Fundamental circuit features
 - (b) Electrometer tubes
 - (c) Metering circuits
 - (d) Components and controls
5. GM Tubes
 - (a) High sensitivity, type BS-
 - (b) Low sensitivity, Type 6C-

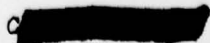

Index (Continued)

6. Power Supply
 - (a) RF oscillator circuit
 - (b) Filter network
 - (c) Components; accessibility of
 - (d) VR tube, corona discharge type
 - (e) Batteries
7. Calibration procedure and curves
8. Field test results and conclusions
9. Inclosures - Charts, Calibration Curves, Plateau Curves

Part II-Model PDR-1 - Suggestions and recommendations for improvement of

1. Case
2. Probe
3. Indicator
4. Electrometer and metering circuit
5. G.M. tubes
6. Power supply

Part III - Model PDR-8; Portable Beta-Gamma Survey Meter

1. Case, probe, indicator, GM tubes and VR tube subject to same remarks as for Model PDR-1
2. Pulse and metering circuits
 - (a) Fundamental circuit
 - (b) Tubes
 - (c) Multivibrator and metering circuit
 - (d) Components and controls
3. Power Supply
 - (a) Vibrator
 - (b) Filter
 - (c) Components and accessibility of
 - (d) Batteries
4. Calibration and procedures and curves
5. Field tests - None to date

Part IV - Model PDR-8; Suggestions and recommendations for improvement of

1. Case, probe, indicator, GM tubes, power supply and VR tube subject to same remarks as for Model PDR-1.

UNCLASSIFIED

- 4 -

Index (Continued)

2. Multivibrator and metering circuits

Part V - Model PDR-11 Portable Alpha Survey Meter

1. Case and physical features
2. Probe
3. Indicator
4. Electronic circuit
5. Photomultiplier tubes
6. Power supply
7. Calibration - None

Part VI - Model PDR-11; Suggestions and recommendations for improvement of

1. General remarks

~~CONFIDENTIAL~~
UNCLASSIFIED

UNCLASSIFIED
~~CONFIDENTIAL~~

REPORT ON NAVY RADIAC METERS

PART I - Model AN/PDR-1(XN-1)

1. (a) Case and physical features. The carrying case and weight of subject meter head the list of undesirable features. The shape of the case alone invites criticism even from the casual observer. From the standpoint of portability the case is strictly out of proportion, bulky and poorly balanced. The latter defect is due primarily to the location of the shoulder strap.

(b) A comparison of the weight of subject meter with that of several similar commercial models indicates a negligible difference in the actual weights, yet the former has the effect of being several pounds heavier after a relatively short time of use in the field or in a vessel. On board, it is noted that to carry subject meter in relatively close places such as on ladders or in passageways results in considerable shocks and jars both to the man who carries same and to the meter itself. To transit a ladder or an escape hatch is equivalent to blocking either off during the time of such transit.

(c) In addition to the major defect noted, several minor defects are mentioned for future reference:

(1) End plate screw holes do not coincide with the tapped holes of the case proper. While it is realized that a different method of securing these plates is contemplated, it seems inexcusable for a reputable manufacturer to allow this condition to exist even in a prototype model.

(2) The center screw and its nut which holds the battery compartment terminal board in place both require grinding off to allow for installation of the Eveready No. 412 battery.

~~CONFIDENTIAL~~

UNCLASSIFIED

UNCLASSIFIED

PART I Section 1 Continued:

(3) The combination clamping and contact making screw which holds the Eveready 412 battery in place requires the use of a pair of needle nose pliers to tighten. Not even an off-set screw driver will suffice to turn this screw.

(4) The shoulder strap location causes the bottom of the meter to project from the users body by approximately 15 degrees, thus increasing the space requirement in transit as well as throwing the entire meter off balance.

2. (a) Probe and probe housing. Both the dimensions and the weight are prohibitive.

(b) Method of insuring watertight integrity are inadequate.

(c) Screw threads strip easily in the micarta piece which supports the outer end of the gm tube mounting and terminal board assembly. This is a contributing factor in the lack of watertight integrity.

(d) Full 360 degree rotation of the beta shutter likely to lead inadvertently to leaving the apertures open.

(e) The necessity for the aperture at the end of the low sensitivity gm tube is not apparent in actual use. It will be noted that this tube has no mica window and is not sensitive to beta particles due to the thick glass envelope; it is mounted in the opposite end of the probe housing which increases the distance from the aperture by approximately 8 cm; and finally the axis of the tube is perpendicular to the plane of the aperture. As a consequence no beta particles have been detected by this tube to date.

(f) The probe housing and cable invite adverse comment from all who have observed same. The entire arrangement is awkward and impracticable for

UNCLASSIFIED

UNCLASSIFIED

- 7 -

~~SECRET~~

PART I Section 2 Continued:

efficient handling of the probe. With the probe unhoused and the cable extended through the hole in the lower end of the cover, the meter will not seat squarely if it is desired to seat same down during a localized survey.

3. (a) The microammeter indicator with the range dial shift mechanism has received favorable comment from all sources. A direct reading indicator dial is highly desirable, however, on the basis of assigning a time limit to personnel on a given mission, it is preferred that the calibration be in terms of $\mu\text{r/hr}$ rather than the existing $\text{r}/24 \text{ hr.}$ rating. The method of accomplishing range shift in this case is quite practical with the two exceptions noted in the following:

(1) The open slots in the side of the indicator case allow for entrance of iron filings and other forms of foreign matter which may cause sticking of the pointer. It is noted that each of the meters has required the disassembly of the indicator and its mechanism for removal of iron filings. Not all of same have been adequately removed.

(2) Insulation on rear of the range dial plates is not adequate. This results in contact of the dial plate with the magnet of the indicator with consequent shorting of the plate supply voltage and violent overthrow of the pointer.

(b) Headphones. Too heavy and lacking in sensitivity for this application.

4. (a) Electrometer Circuit. Reference circuit schematic, Fig. 1. The circuit employed in subject meter is a conventional balanced direct current amplifier. This type of circuit is commonly used where the input

C ~~SECRET~~

UNCLASSIFIED

UNCLASSIFIED

- 8 -

PART I Section 4 Continued:

voltage and current are of extremely small value such that RC or impedance coupling cannot be used and wherein direct coupling of the input to the first grid is required as in the Zeus and similar ionization chamber type instruments. Although the circuit appears to be a simple, straight forward amplifier, it is noted that any form of direct current amplifier is subject to inherent disadvantages not encountered in other types. This is particularly true with regard to its instability and tendency to drift due to leakage and to the use of tubes which do not have similar characteristics. Considerably more care must be taken in the original manufacture and in subsequent maintenance work to assure proper operation. Highest quality components are required and the interior of the meter must be maintained absolutely moisture free at all times if instability and drift are to be prevented.

(b) All that has been said of this circuit has been confirmed on each of the 15 meters shipped for this operation. Drift and instability were apparent from the very beginning. Investigation revealed that the cause of both was due to poor insulation and poor components in the grid circuit of the input tube. Practically all insulation material used in the grid circuit proved to be defective with the resistance varying from 100 megohms to as low as 20 megohms. It can be demonstrated that the resistance of this circuit to ground and to other potentials must be of the order of 10⁹ or higher, depending on the input resistance, if leakage is to be eliminated for practical purposes. In practice, the insulating material of the input grid circuit must have a resistance at least 100 times greater than that of the input circuit to insure that at least 99% of the input current flows through the grid resistor. Any appreciable current which flows through a

UNCLASSIFIED

UNCLASSIFIED

- 9 -

PART I Section 4 Continued:

leakage path will decrease the sensitivity of the circuit as well as change the calibration.

(c) The following material and components were found to be defective for this application:

- (1) All micarta or composition terminal boards.
- (2) The fiber insulation bushings on the jacks between the battery compartment and the chassis compartment.
- (3) All calibration (Grid circuit R) potentiometers. The potentiometers are of very poor quality even if we neglect the leakage factor.

(d) In addition to the foregoing, an apparent saturation effect has been noted above the mid-scale point of the 0-10 scale. It is possible that leakage is also causing this effect since it is possible to effect an improvement by thorough drying of the unit prior to use. Additional tests will be made to determine the source of trouble.

(e) The metering portion of the circuit is not entirely satisfactory. The RC time constant of 1 second in this circuit permits fluctuations on the order of 30% to 50% of full scale on the most sensitive range at or near background counting rate.

5. GM Tubes - Reference Charts 1 to 17 inclusive.

(a) The type BS, high sensitivity, mica window gm tube is considered to be physically superior to the average of this class. For field use the more rugged construction of the type BS tube is preferred over the more conventional thin-walled glass tubes presently used in the commercial models. Reference to Chart 16 reveals that three of the BS tubes have been broken in handling; two had the mica window ruptured in some manner, possibly by thumb

~~CONFIDENTIAL~~

UNCLASSIFIED

~~CONFIDENTIAL~~
UNCLASSIFIED

PART I Section 5 Continued:

or finger; one was broken by applying excessive pressure on the 6-32 screw on installation. The end mica window constitutes the weakest point in this tube from a physical standpoint. The value of the mica window for ordinary field survey work is subject to question in view of experience gained on the present project. For localized survey work such as in close places in a ship or plane or for point source determinations such is undoubtedly required. However, as noted in Section 2, the present method of mounting the tube will not permit efficient use of the mica window.

(b) Reference to Charts 1 to 16 inclusive reveals that the plateau on subject tubes is on the average quite poor. A slope of 40% per 100 volts is noted on two in particular while none have a slope of less than 10%.

(c) Reference to Chart 17 reveals that the voltage pulse developed on the center electrode of subject tubes is on the average considerably higher than on several conventional commercial type tubes. The voltage noted on several in particular was unbelievably high and a close recheck was made to confirm same. As a means of further confirming this fact, the current was measured simultaneously in the circuit shown in Figure 2. In all cases the sample used to excite the tube was placed equidistant from the tube under test.

(d) Type 6C, low sensitivity GM tube. Reference to Chart 16 indicates the disposition of subject tubes from a physical standpoint. This tube is characterized by its relatively small diameter and in particular by the relatively small cathode of sensitive area. It is also noted that the possibility of obtaining a very rugged tube in this type offers much hope for its adoption in field type instruments. As noted on the chart, however, at least two of the tubes were cracked in normal handling of the meters in which

~~CONFIDENTIAL~~

UNCLASSIFIED

~~CONFIDENTIAL~~
UNCLASSIFIED

PART I Section 5 Continued:

each was located. It is assumed that improper annealing is the cause of this trouble since none of the tubes were dropped or otherwise subjected to undue shock.

(e) Several of the type 6C tubes were too long to fit the clip holder on the mounting board assembly in the probe housing. This necessitated alteration of the location of the clip. It is assumed that future production of this tube contemplates the sealing off of same at a point near the cathode similar to the two which were received with two respective meters.

(f) Attention is invited to the apparent electrical effect created by the extended insensitive end of this tube in the following and on the plateau curve sheets. The latter will also reveal that practically none of the 6C tubes had what might be termed a plateau on the initial count versus anode voltage checks. Instead the counts increase on a relatively straight line with an increase of voltage. In no case is there a plateau in excess of 50 volts. In some cases a state of almost continuous discharge is reached at or near the operating potential as fixed by the VR tube in the circuit.

(g) Of particular interest is the apparent change in counting rate of the type 6C tube after a few minutes of operation. This increase was noted only at or near the threshold voltage point, the latter of which did not change with repeated rechecks. This characteristic did not become apparent in time to check a greater number of the tubes for more conclusive confirmation; however, four were noted particularly. Two of these were stabilized in normal counting and during the rechecking as indicated on their respective curves. It was recalled that the halogen gases do not mix as readily as other more commonly used gases, therefore it was assumed that such was the case here particularly in the "dead" or insensitive end of the tube.

~~CONFIDENTIAL~~
UNCLASSIFIED

UNCLASSIFIED

PART I Section 5 Continued:

Also the type BS tube, with practically its entire volume comprising the sensitive area, did not exhibit this characteristic. Working on this assumption, two of the tubes were subjected initially to a flashover voltage of approximately 100 volts in excess of their normal operating potential for a period of ten seconds. Repeated checks of the count rate at the threshold voltage were made thereafter with no change occurring at any point.

(h) In the course of investigating the saturation effect previously referenced, one of the type 6C tubes flashed over in a field of relative high intensity (within 1 meter of the 250 mg Ra source). The tube was removed from the meter and tested on the bench with various potentials applied. It continued to discharge continuously even with the voltage reduced to a value 200 volts less than the normal threshold potential. It was assumed that the halogen quenching gas had been absorbed by the electrodes; consequently the tube would continue in a state of discharge as long as the voltage was applied.

(i) Reference to Chart 17 also indicates that the current drawn by the types BS and 6C tubes is considerably higher than that of other types of tubes. It is noted that the indications for the 6C type show only that current drawn at the same intensity of gamma radiation as was used with the more sensitive type BS tube and the commercial types. With higher intensities the 6C tube draws current, which suggests an answer to the trouble experienced with the VR tubes as detailed in Section 6. This can be said also of at least one of the BS tubes. It is also noted that the type 6C tube can be direct connected to a microammeter of 20/uA fundamental sensitivity rating and made to indicate gamma ray intensities on the order of 2 to 40 r/24hr. The exposure figures have not been fully confirmed, nor

UNCLASSIFIED

UNCLASSIFIED
~~CONFIDENTIAL~~

PART I Section 5 Continued:

has the linearity of the indications; however, it is suggested that the possibility of developing a detector based on this idea warrants consideration. It is realized that to do so the tubes themselves would have to be standardized to a closer degree than now exists.

(j) With reference to the voltage characteristics of the 6C and BS GM tubes, the relatively high pulses developed on the central electrode can only be explained in terms of a much higher distributed capacity of the electrode. It is noted that this electrode is considerably larger than that normally used in the conventional type tubes. The size of the voltage pulse appearing on the central electrode is determined by the distributed capacity of the center wire and anything connected electrically with it as well as to the number of charges arriving thereon.

(k) It is noted that all of the type 6C tubes have a higher counting efficiency than would normally be expected considering the projected cross-sectional area of the sensitive portion of this tube as compared to that of the type BS tube. This condition results in a counting rate which is not proportional to that of the type BS tube. A limited amount of compensation for this condition was effected in the PDR-8 by changing the sensitivity of the high intensity circuit.

6. Power Supply.

(a) The RF power supply operation is satisfactory for normal use. Some RF voltage is introduced into the electrometer circuit when the chassis is removed from the case and the battery extension leads are not properly placed. This leads to a perceptible amount of drift in the indications of the microammeter indicator which can be the cause of unnecessary work unless the trouble is recognized. No trouble has been experienced in this connection with the chassis in the case in a normal operating condition.

UNCLASSIFIED
~~CONFIDENTIAL~~

UNCLASSIFIED

- 14 -

PART I Section 6 Continued:

(b) No appreciable ripple voltage is apparent in the out-put of the filter network.

(c) All components appear to be satisfactory for this application and they are reasonably accessible for replacement or test purposes.

(d) VR tube, corona discharge type. Considerable difficulty has been experienced with several of these tubes. As indicated on chart 16 at least two have failed while one was inoperative upon receipt. The latter did not show any indication of taking over control at potentials well below and above the normal regulating point. It is also noted that several have experienced a decrease in the value of the control voltage to a point below the threshold voltage of the GM tubes. One in particular has decreased from its former rating of 640 volts to a value of only 590 volts. This placed the regulating point below the GM tubes with which it was used.

(e) It is recalled that mention was made at NRL of the apparent change in frequency characteristic of the RF power supply with a resultant change of voltage. This condition has not been confirmed in a single case and it is submitted that the change in the output voltage of the power supply is due to the erratic characteristics of the VR tube. As suggested in Section 5 (1) it is possible that the current used by the GM tubes is excessive for the VR tube. No information is available at present on the current rating of the corona discharge type of VR tube. However, this may find confirmation in the fact that the only VR tubes which have failed while in use are those which have been used with meters exposed to relatively high intensity radiations while checking the latter on the 0-10 r scale.

~~CONFIDENTIAL~~

UNCLASSIFIED

UNCLASSIFIED

- 15 -

~~CONFIDENTIAL~~

PART I Section 6 Continued:

(f) Batteries - Reference Chart 18. All batteries are satisfactory for the application, however, the method of securing same in the battery compartment is inadequate.

7. (a) Calibration Procedure. One only of the original (15) units has been calibrated with any degree of success. This one was overhauled to eliminate the leakage referenced in Section 4. This was accomplished by boiling all of the fiber insulators in bees wax; replacing the micarta terminal boards with lucite boards; isolating the anode connection of the type 6C GM tube from the terminal board in the probe and finally by replacing all four of the calibration potentiometers with Allen & Bradley or equivalent. This eliminated leakage barring the entrance of moisture which was periodically dried out prior to a calibration check.

(b) It was not considered practicable to treat additional units in the preceding manner due to the fact the potentiometers required were not available except from the spares for other meters.

(c) Calibration was effected by using two standard Ra sources, 48.7 mg and 231.7 mg respectively at distances of 20 meters to 0.5 meter. As noted on the calibration Chart 19-22 saturation was indicated on the upper portion of the 0 to 10 r/24 hour range at distance of 1 meter and closer. Continued investigation is being conducted to determine more accurately the exact cause of same.

8. (a) Field test results. The one unit in operating condition was field tested with three similar commercial models namely, the Victoreen Model 247A, the Zeus and Beckman's Model MX-6. Since the respective ranges of the three meters do not coincide over a very wide range it was not possible to obtain more than approximately six readings that could be

UNCLASSIFIED

~~CONFIDENTIAL~~

AD-A078 554

JOINT TASK FORCE SEVEN WASHINGTON DC
OPERATION SANDSTONE, NUCLEAR EXPLOSIONS. SCIENTIFIC DIRECTOR'S --ETC(U)
1948

F/G 6/18

UNCLASSIFIED

NL

2 OF 2
AD
AD 7855.4

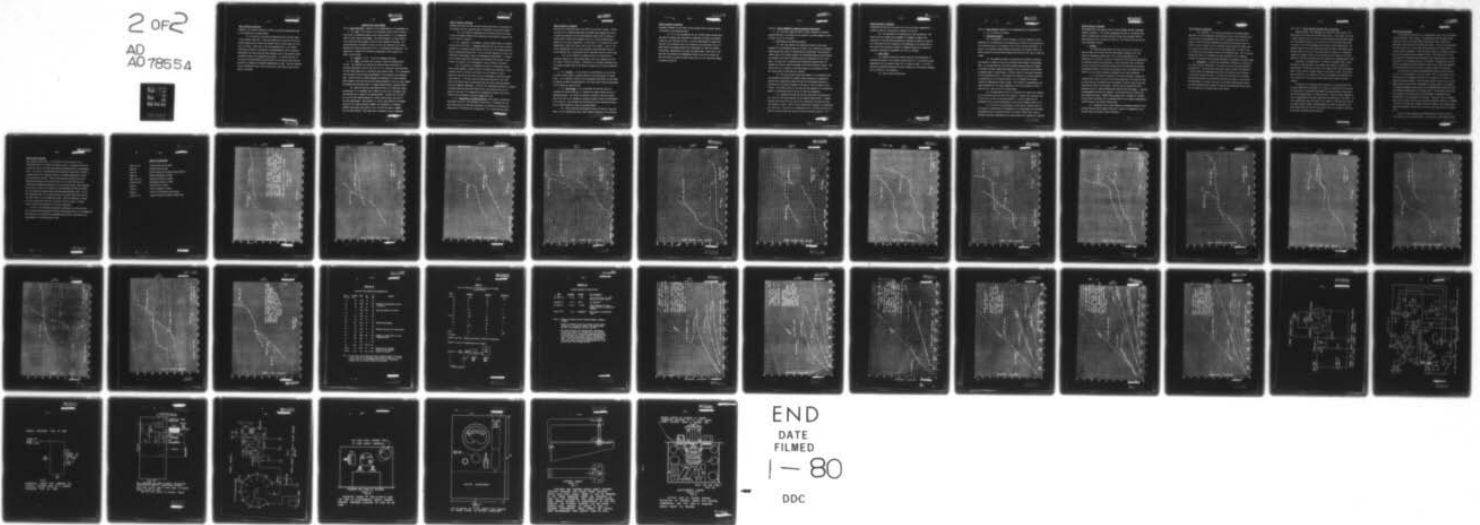

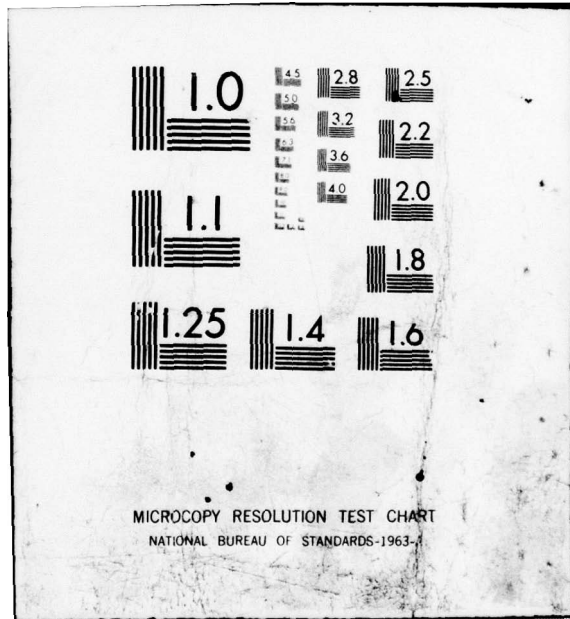

MICROCOPY RESOLUTION TEST CHART
NATIONAL BUREAU OF STANDARDS-1963-1

UNCLASSIFIED

- 16 -

PART I Section 8 Continued:

compared. The results indicated the PDR-1 to be within approximately 10% of the readings of the other meters.

(b) No trouble of any kind was experienced with the model PDR-1 on this initial field test. There was practically no zero drift after the initial warmup period of about five minutes which is quite normal for this type of circuit. Since this is the only operating unit, it was deemed advisable to prevent the possibility of contamination as much as possible. Consequently the entire unit was kept inclosed in one of the plastic covers provided for one of the commercial type meters. It is noted that two of the plastic carrying straps were used by two of the party as belts with the intention of checking for possible contamination of same. None was observed; however, additional tests of this nature will be made during future field tests of the meter.

UNCLASSIFIED

UNCLASSIFIED

~~CONFIDENTIAL~~

- 17 -

REPORT ON NAVY RADIAC METERS

PART II Model PDR-1(KN-1) Suggestions and Recommendations for improvement of.

1. (a) Case - On the basis of the objections noted in Part I Section 1 and in view of experiences gained on the current project, it is recommended that the entire case be redesigned. The revised design to include revision of the probe and power supply as noted in their respective sections. The latter will make it possible to reduce the over all dimensions by at least 25% while the probe revision will result in an additional 10% reduction. The weight will be reduced 25 to 30% and an improvement will be gained in a better balanced meter.

(b) Figures - 3 to 8 indicate (2) suggested revisions.

2. (a) Probe - No effort will be made to revise the existing probe as such. The necessity for replacing the type 6C tube in the probe is seriously questioned in view of the fact it is not sensitive to beta particles and will detect gamma rays of relatively high intensity only. It is recommended that the type 6C tube be mounted permanently on the chassis of the electronic unit. This will have the added advantage of eliminating the three conductor cable presently used with the probe and making possible the use of a much lighter and smaller two-conductor cable or a single conductor with a grounded shield.

(b) Since the type BS, mica window GM tube is of relatively rugged construction, it is considered that a probe for same can be reasonably light and certainly not as large as the existing probe. It seems that this tube is or can be more readily adapted to a stream lined housing than some of the more common-types. The provision for using a 6-32 screw in the connecting end to the central electrode suggests the possibility of screwing a standard type banana plug therein so that the unit may then be plugged into the probe housing. This would make it possible to have a completely

~~CONFIDENTIAL~~

UNCLASSIFIED

UNCLASSIFIED

- 18 -

PART II Section 2 Continued:

inclosed probe with the rear end well sealed against water and moisture and the exposed end with a screw-on type of combination cap and beta shutter.

(c) It is further recommended that the entire subject of probes be more thoroughly reviewed before additional radiac meters for general use in the field are designed.

3. (a) Indicator - Microammeter - Provide suitable means for sealing of the slots in the side. A suggested method is the use of felt or similar material to be cemented on both sides of the slots so that foreign material will be effectively filtered out. This is the more important in view of the relatively strong magnets used in the Westinghouse microammeter. It cannot be too strongly urged that some means for preventing the entrance of iron filings be provided if this arrangement of scale shifting is retained.

(b) The question of headphones is subject to additional review. Where urgency demands a quicker method of determining the existence of high intensity fields of radiation and when it is not necessary to make a quantitative analysis of this field, the use of headphones or audible signals seems adequate. At the same time it hardly seems necessary to have both visual and audible signals, particularly when the latter generally entails the use of separate headphones. In view of the development currently in progress on several types of audio meters which can be very easily carried in the pocket of the user, it is suggested that headphones be omitted from future models of meters designed for general field survey use.

4. (a) Electrometer and Metering Circuit - The inherent difficulties encountered in the d.c. type amplifier should serve to discourage its use where input pulses of sufficient magnitudes are available for exciting the input grid of a conventional RC coupled type. It is noted that the pulses

UNCLASSIFIED

UNCLASSIFIED

- 19 -

~~CONFIDENTIAL~~

PART II Section 4 Continued:

from the type of GM tubes used in the PDR-1 are far above average. In fact the value of the voltage pulses from the halogen tubes suggests the use of a single tube amplifier for the more sensitive ranges while the amount of current drawn by these tubes suggests the use of a direct-coupled microammeter for the higher intensities. In any event, it is certain that a more rugged type of meter will result from the use of the halogen tubes in view of the possibilities of using a less sensitive indicating meter such as a 0-1 MA movement with a conventional type of amplifier circuit to drive same.

(b) If it is desired to combine the use of a GM tube and an ionization chamber in a single survey meter, then it is suggested that the d.c. type of circuit be retained. Otherwise it is strongly recommended that the circuit presently used in the PDR-1 be replaced in the future production models.

5. (a) GM Tubes - In the absence of qualifications on the subject, no effort is made herein to suggest methods for the improvement of subject tubes. It is submitted, however, that considerable improvement of both types is required to effect standardization to the point where reliable replacements can be stocked for general issue.

6. (a) Power Supply - It is recommended the RF power supply be replaced with either batteries or a vibrator and single battery for use in subsequent models. The latter can result in a saving of space and weight only in the event it is designed to provide B supply to meet all requirements of the circuit. This includes both the GM tubes and the electronic circuit. This is quite feasible as noted in the Model PDR-11.

(b) Where relatively low-voltage GM tubes, 600 volts or less, are used, it can be demonstrated that a power supply consisting of all batteries

UNCLASSIFIED

~~CONFIDENTIAL~~

UNCLASSIFIED

- 20 -

PART II Section 6 Continued:

throughout occupies no more space, and the weight will not greatly exceed, the vibrator or RF Oscillator type.

(c) It is also recommended that the various battery manufacturing firms be extended some inducement to undertake the design of batteries solely for use in GM tube circuits. It is not unreasonable to assume that the size of an individual cell can be reduced to the approximate size of a shirt button thus making possible the construction of a 200 volt battery, for instance, approximately one third the present size. Noted also is the fact that the miniature and subminiature field is but in its infancy and with the advent of printed circuits there will be an ever increasing demand for smaller batteries.

UNCLASSIFIED

- 21 -

~~CONFIDENTIAL~~

PART III - Model AN/PDR-8(X) Portable Beta-Gamma Survey Meter.

1. (a) The case, probe, GM tubes, VR tube, indicator and general physical features of the PDR-8 are all subject to the same remarks as given in Part I and II for the PDR-1.

2. Multivibrator and Metering Circuit.

(a) The first stage of the electronic circuit of this meter consists of a multivibrator which can be said to be a circuit for converting random pulses into pulses of uniform width and amplitude. The second and output stage of the circuit consists of a frequency metering circuit wherein the average of the number of pulses received is indicated on a d.c. type meter. The meter has a relatively high capacitance shunted across its terminals in order to damp the movement of the meter sensitive element. The latter action is a function of the time constant or the product of RC in the circuit which in this case is 2 seconds.

(b) The type 3A5 dual triode tube appears to be satisfactory for this application although the filament current required, as indicated in Section 3(d), automatically limits the life of the filament battery to a relatively short period as compared to the life of the "B" battery in the circuit. The pentode section of the type 1S5 tube operates in a satisfactory manner as the frequency meter tube and to drive the headphones.

(c) Considerable difficulty has been experienced in maintaining the circuit in operating condition due to numerous minor defects. Frequent failures have occurred with the result that calibration and field test have been limited in scope. After the minor defects were remedied, the sensitivity was still poor. This was due in considerable part to the fact that both the plate and screen supply were varied to effect sensitivity control. It is

~~CONFIDENTIAL~~
UNCLASSIFIED

UNCLASSIFIED

PART III Section 2 Continued:

considered that this was the result of an error in wiring, consequently a change was effected as indicated in Section 2 of Part IV.

(d) All components are satisfactory for this application. The value of R11 was changed from 15 Megohms to 2 Megohms to improve the indication of the sensitivity adjustment as detailed in Section 2, Part IV. It is also noted that the coupling of the headphones to the screen grid of the type 1S5 tube through C5 results in adequate volume on all ranges and represents considerable improvement over that of the PDR-1.

3. Power Supply.

(a) Vibrator-batteries as power supply for this application is satisfactory subject to the remarks on same in Part II. No trouble has been experienced with the vibrator proper nor the output of same. It is noted that with inadequate shielding the audible component of the vibrator contactor can be detected in the headphones.

(b) Filter network satisfactory.

UNCLASSIFIED

UNCLASSIFIED

- 25 -

PART IV - Model PDR-8(X) Suggestions and Recommendations for improvement of.

1. (a) As noted in the index.
2. Electronic Circuit.

(a) As indicated in Part I Section 4, an RC or impedance coupled amplifier is to be preferred in this application in view of the characteristics of the gm tubes which it is proposed to use in both the PDR-1 and PDR-8. In spite of the numerous defects referenced previously, the circuit used in the latter promises to give much more trouble free service in the long run than the former.

(b) The defective control of sensitivity was remedied by changing the circuit in a manner to vary only the screen grid voltage of the metering tube. At the same time the "B" battery voltage check provision was changed to include only that voltage which appears on the screen grid thus providing an improved means of establishing a reference point for the proper adjustment of the sensitivity control. This control was thought to be further improved by substitution of the 2 megohm resistor for the 15 megohm in the meter circuit for measuring the screen voltage. This results in approximately full scale deflection for the proper adjustment of the screen voltage and can be used also as a check of the "B" voltage proper.

(c) The improvement noted in (b) increased the sensitivity; however, on the low scales there was still more required. Further tests indicated that the grid bias on V102 and V103 was excessive. A value of 10½ volts was determined to be the most satisfactory, in lieu of the original value of 15 v.

(d) In view of the versatility of this type of circuit as well as the economy of construction and maintenance, it is recommended that additional development work be conducted on this or a similar circuit with a view to effecting additional improvements for a model which can be produced in quantity.

UNCLASSIFIED

UNCLASSIFIED

PART IV Section 2 Continued:

The multivibrator tube, type 3A5 with its high filament current requirement should be replaced. It is further emphasized that with the relatively high value of voltage pulse available from the halogen type gm tubes, there is every indication that a single tube meter or a dual purpose tube can be used with satisfactory results.

3. VR Tube.

(a) Additional experiments with the VR tube in the circuits of both the PDR-1 and the PDR-8 and with same removed, indicates that these tubes are undoubtedly causing some of the trouble experienced in the calibration of the meters. Reference to Charts 20 to 24 inclusive demonstrates the apparent results most graphically. On the 0-10 scale curve of Chart 24 it may be noted that the indicated reading still does not meet the linearity requirement; however, the trouble was apparently in the low sensitivity tube itself as it has failed altogether, subsequent to the last calibration.

(b) In at least one instance it was found necessary to change the voltage control value of one of the corona discharge type of VR tubes in order to bring same into coincidence with the plateaus of both the high and the low sensitivity GM tubes in the circuit. This was done as indicated in Fig. 3 through the use of a shunt resistance net across the VR tube proper. A decrease of approximately 50 volts was required. It was found that the circuit used gave excellent results. Further tests indicate that a decrease of a hundred or more volts is possible with no apparent effect on the control characteristic of the VR tube at the revised control value.

(c) Components used in power supply are satisfactory except for the VR tube which has been discussed in Part II. Additional information on the VR tubes will be outlined in Part IV Section 3.

UNCLASSIFIED

UNCLASSIFIED

PART IV Section 3 Continued:

(d) Batteries - "B" batteries consisting of two Eveready #467, 67½ volts, in series considered satisfactory in view of the relatively light current drain of approximately 4 MA. The "A" batteries, with a drain in excess of 270 MA even when connected in parallel will seriously limit the period of time the meter can be in operation without having to replace same. If a minimum of 1.2 volts is set as the low voltage limit, the life of the "A" battery will hardly exceed 16 hours of intermittent duty. The "C" battery voltage was found to be excessive for this application with a resultant decrease in sensitivity that required adjustment by changing the battery proper.

4. Calibration - In view of the difficulties involved in correction of the circuit proper, calibration of this meter has been spotty and generally unsatisfactory. Two curves have been drawn, however, which will indicate to a limited extent the improvement effected in the sensitivity and linearity as indicated on Charts 23 and 24. The first was made after the corrective measures were applied, the second was made after the removal of the VR tube. The improvement is evident in the case of the second particularly; however, the final improvement will require an improved low sensitivity GM tube since this is apparently the weakest spot in the circuit.

UNCLASSIFIED

PART V and VI - Model AN/PDR-11 Portable Alpha Survey Meter.

General Remarks - The compactness and relatively light weight of the PDR-11 make for an ideal type of field survey meter. The extended probe with a remote indicator built in is also a desirable feature although there seems to be considerable question as to the reason for the odd shaped probe head. The latter is due to the necessity for the light concentrating system. The relative merits of the light collecting system will not be discussed herein; however, suffice it to say that any such system is subject to a relatively large loss of light by virtue of the distance from the source of the light proper and the final collecting plate or cathode of the photomultiplier tubes.

In general, the engineering of the PDR-11 is considered fair to good. The desire to make the whole a very compact unit results in sacrifice of accessibility of components; however, it is thought that testing and replacement of parts could be effected without too much loss of time. The present model leaves much to be desired in the way of ruggedness and durability but it is thought that the production model would include proper corrective measures.

The principle of detecting alpha particles by a photomultiplier tube has been demonstrated successfully by a number of authorities on the subject. The detection of a relatively small number of alpha particles by this means has not been demonstrated in a practical sense. That the latter statement is true is demonstrated in the poor sensitivity characteristic of the PDR-11. It can be demonstrated that this meter is not capable of detecting less than one to several hundred thousand disintegrations per minute as compared to the Model DM-4/PD which will detect and indicate with a fair degree of accuracy a few hundred disintegrations per minute.

UNCLASSIFIED

UNCLASSIFIED

- 27 -

~~CONFIDENTIAL~~

PART V and VI Continued:

In his paper on the subject of a scintillation counter for the detection of alpha particles, Sherr states that calibration of his instrument, which formed the basis for the Model PDR-11, showed that 1 ua of current was equivalent to 300 alpha particle pulses per second. Under the same conditions the dark current was 0.5 ua so that 150 alpha pulses per second result in a current equal to background. Using the latter figure as a minimum, the pulses which can be counted per minute amount to 9000. This figure does not take into account the relatively poor efficiency of the light system nor the poor sensitivity of the amplifier circuit of the PDR-11. Disregarding all other factors and accepting the 9000 counts per minute still leaves the instrument less sensitive than the top of the most sensitive range of the $M-4/PA$.

The difficulty in using the photomultiplier tube as an alpha detector is due to a basic weakness of the tube itself. That is the presence of the dark current or the emission of photons in the absence of any light on the cathode and dynode surfaces. While the dark current is given as only a very small fraction of the current occasioned by incident light on the cathode, it assumes considerable proportions with the amplification necessary to raise the incident photoelectrons to a workable level. The net result is that the most energetic alpha particles and those appearing in relatively heavy concentrations can be detected by this means. Through the use of a cooling agent such as liquid nitrogen and an elaborate electronic system it is possible to detect the heavier less energetic particles; however, such a method could hardly be considered practical for a portable survey meter such as is desired here.

To date no alpha particles have been detected by either of the two units shipped for the current project. It is noted that the screens on both

UNCLASSIFIED

~~CONFIDENTIAL~~

UNCLASSIFIED

- 28 -

PART V and VI Continued:

have developed light leaks. In both cases the screen seems to have deteriorated due to the effect of moisture or age. A naphthalene screen was prepared for one of the units using 100% pure naphthalene with no improvement noted. The circuit of the amplifier was thoroughly checked with no trouble indicated unless the threshold voltage was increased excessively in which case oscillations occurred. Under normal operating conditions the only indications appearing on the grid and plate of the input tube were the voltage pulses which were apparently due to the dark current. These appeared in the form of "hash" on the screen of an oscilloscope and would not appear with the excitation voltage removed from the photomultiplier tubes. On the two referenced units it is also noted that the indicator meter was still in the plate circuit of the preamplifier stage. This was admittedly a mistake if for no other reason than that of having to read the meter in reverse, that is, zero set was effected at full scale deflection.

In view of the preceding and equally as important, the relative minor role of alpha particle detection in initial field survey work, it is recommended that production of the PIR-11 be suspended pending further developments and improvements of the photomultiplier tubes.

UNCLASSIFIED

UNCLASSIFIED

~~CONFIDENTIAL~~

INDEX TO ILLUSTRATIONS

Chart 1 to 15	Plateau Curves for GM Tubes
Chart 16	GM and VR Tube History
Chart 17	GM Tube Current and Voltage Characteristics
Chart 18	Battery Complement for PDR-1
Chart 19 to 22	Calibration Curves for PDR-1
Chart 23 to 24	Calibration Curves for PDR-8
Figure 1	Basic Circuit of PDR-1
Figure 2	Circuit Schematic of PDR-8
Figure 3	Circuit for Lowering VR Tube Rating
Figure 4 to 8	Suggested Design for PDR-1 and PDR-8 Case

UNCLASSIFIED

~~CONFIDENTIAL~~

UNCLASSIFIED

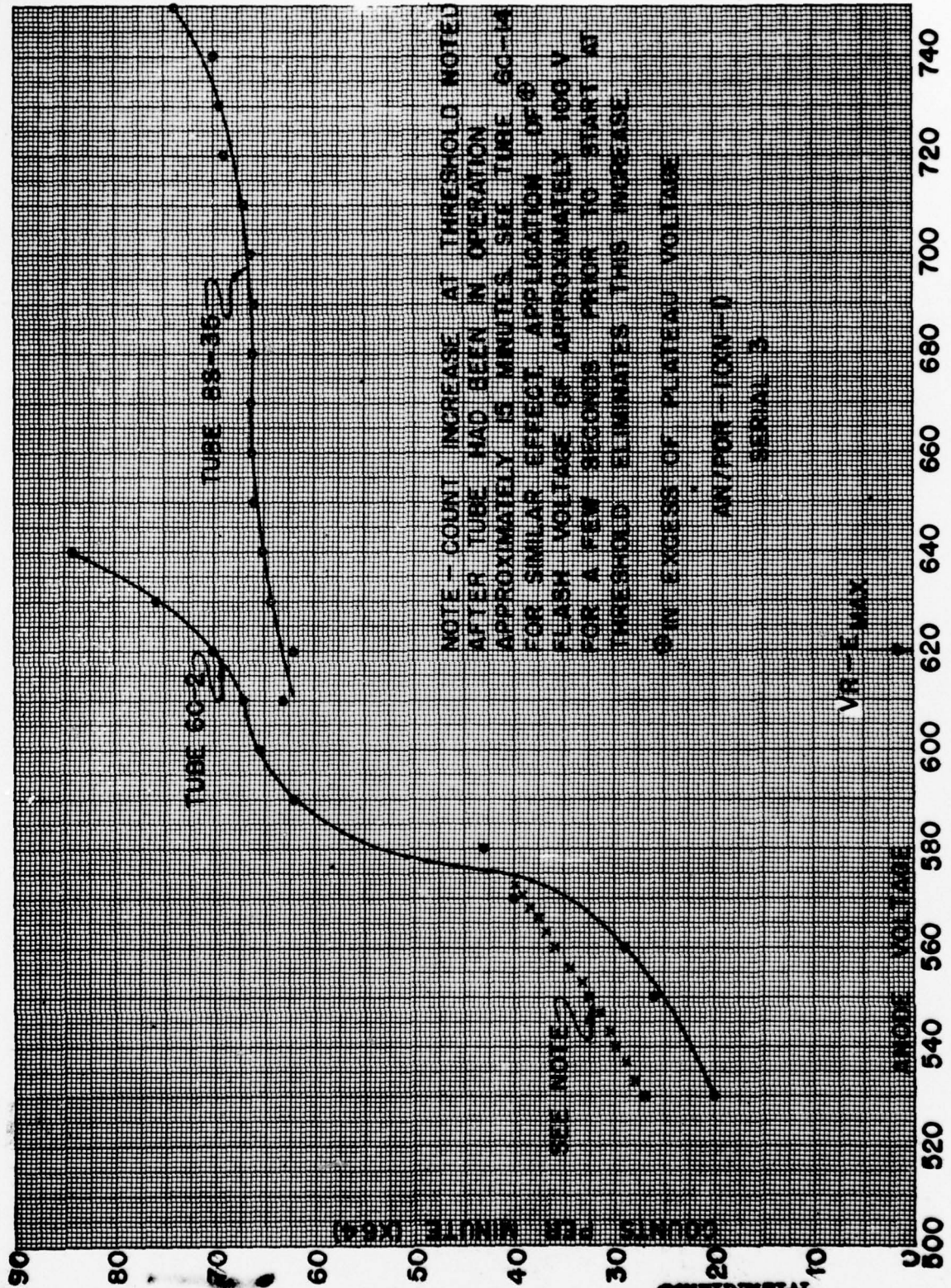

UNCLASSIFIED

~~CONFIDENTIAL~~

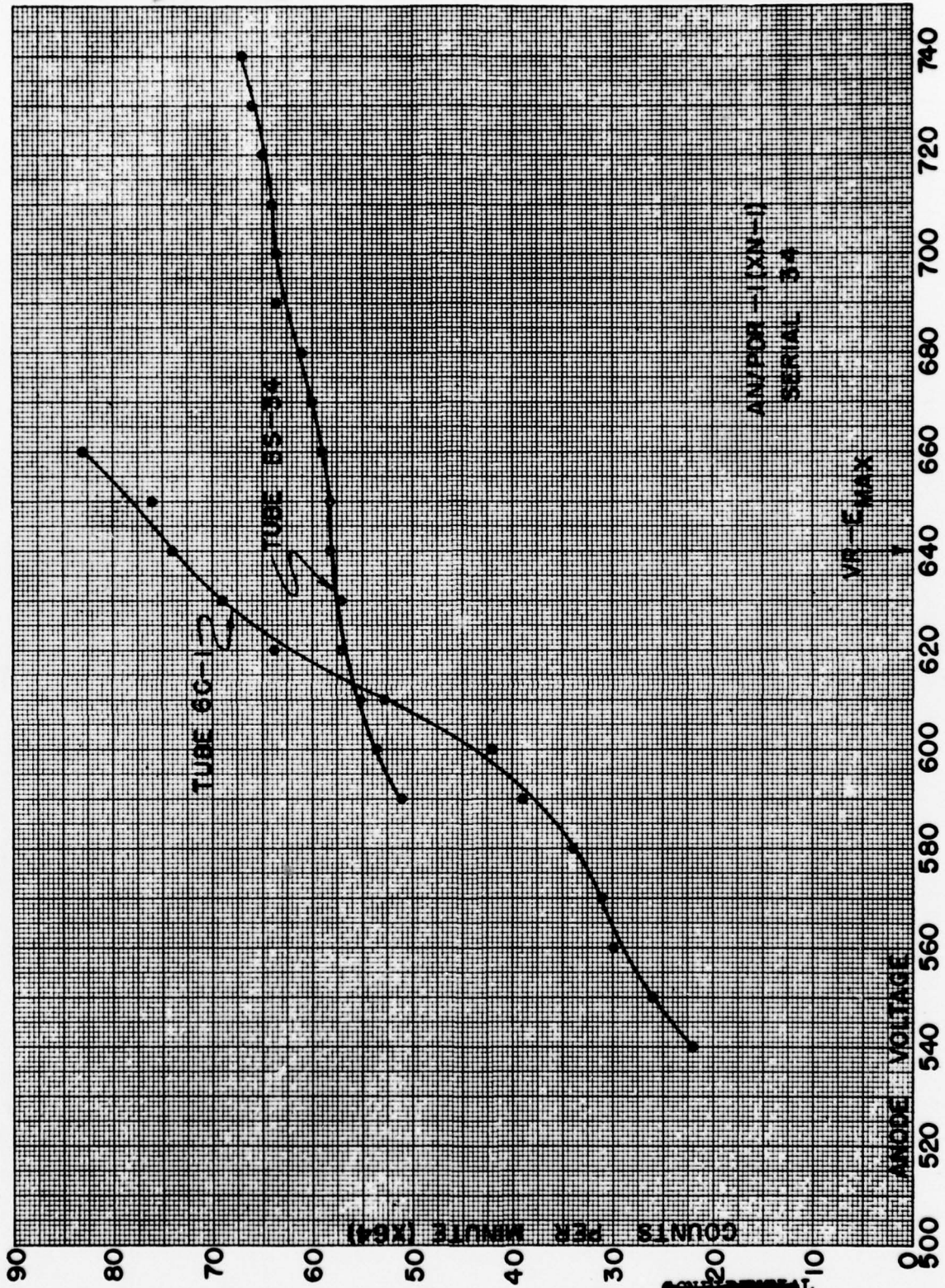

AM/POI - (XN-1)
SERIAL 34

UNCLASSIFIED

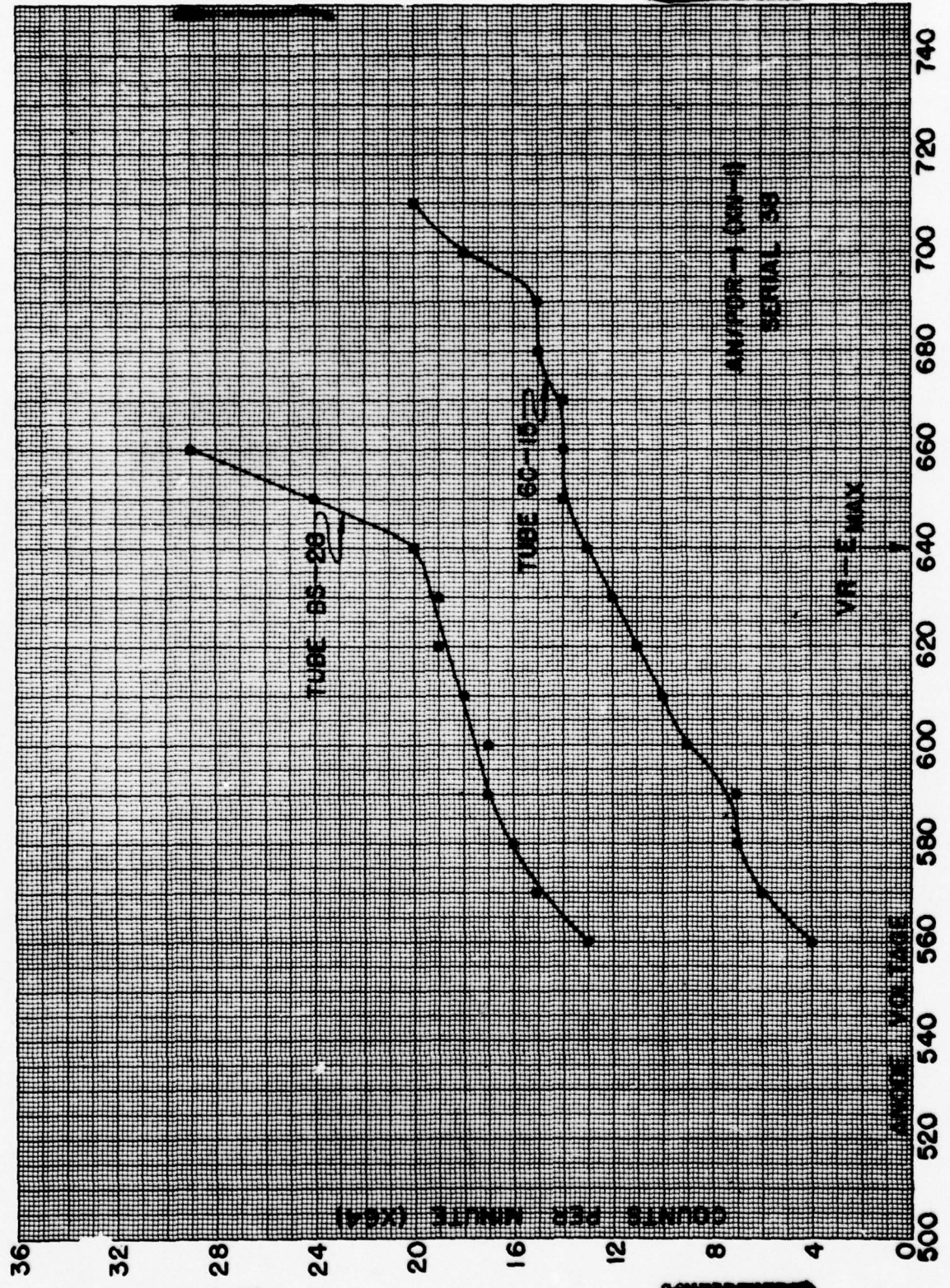

UNCLASSIFIED

UNCLASSIFIED

- 33 -
Chart 4

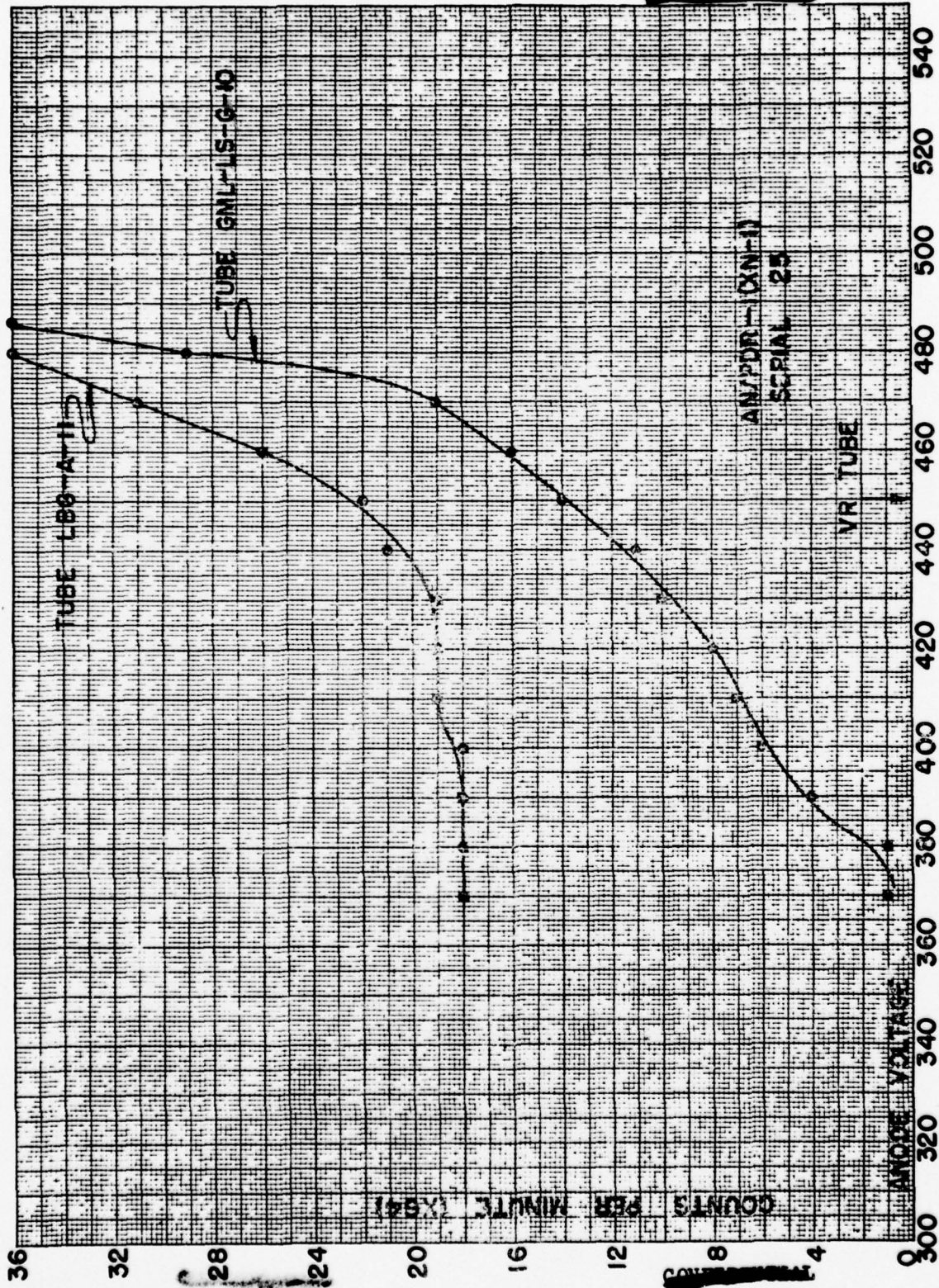

UNCLASSIFIED

UNCLASSIFIED

- 34 -
Chart 5

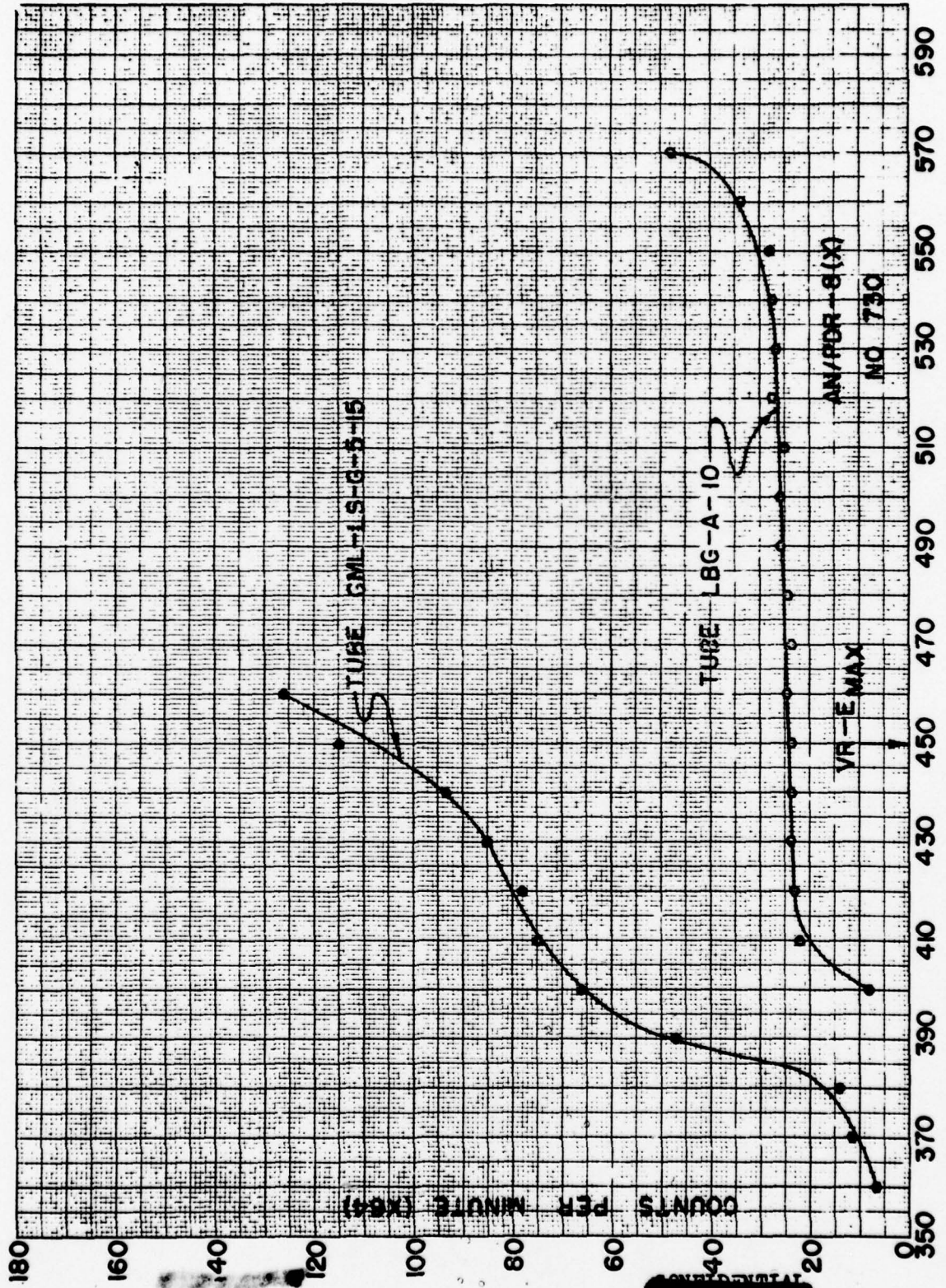

UNCLASSIFIED

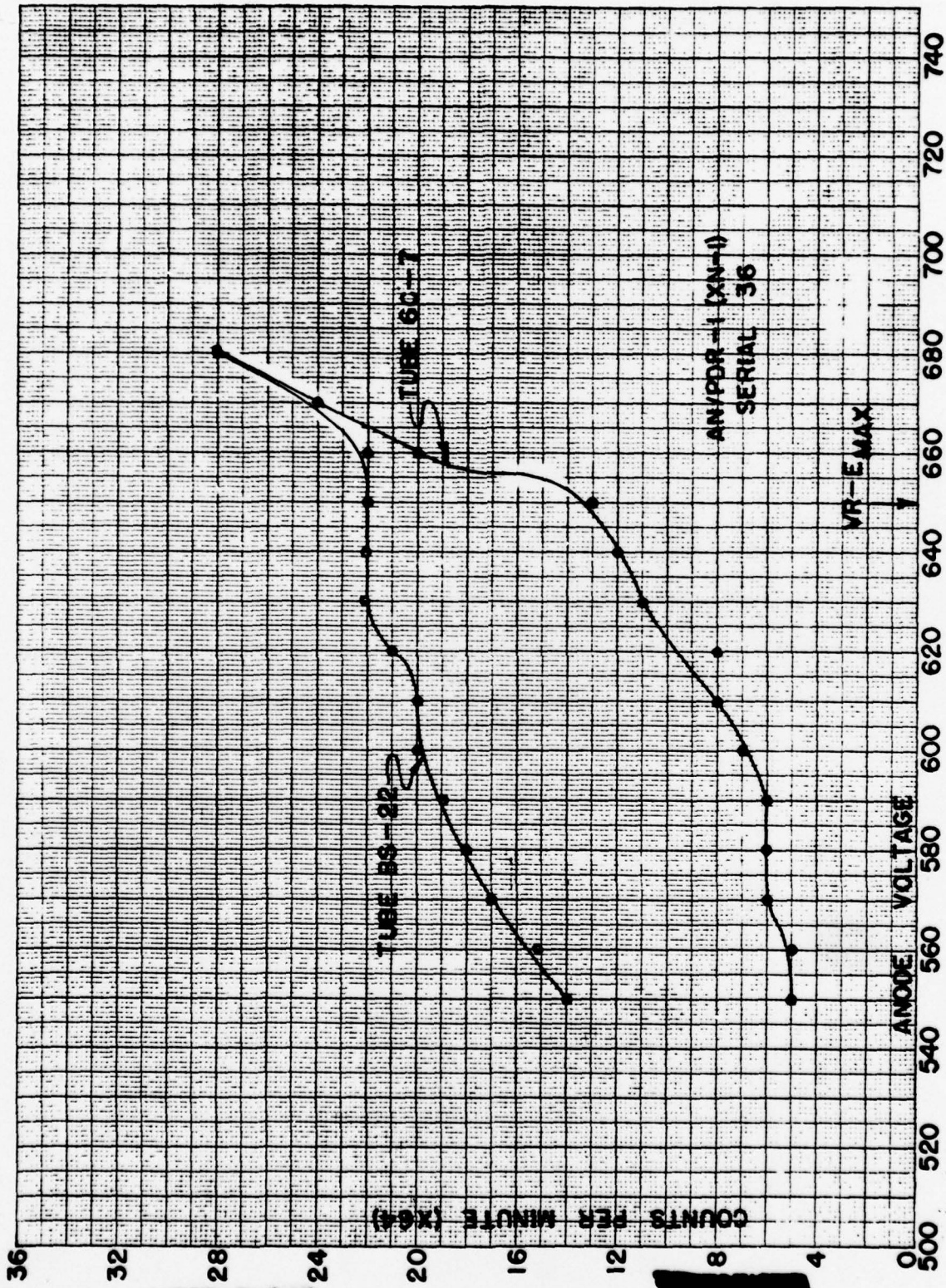

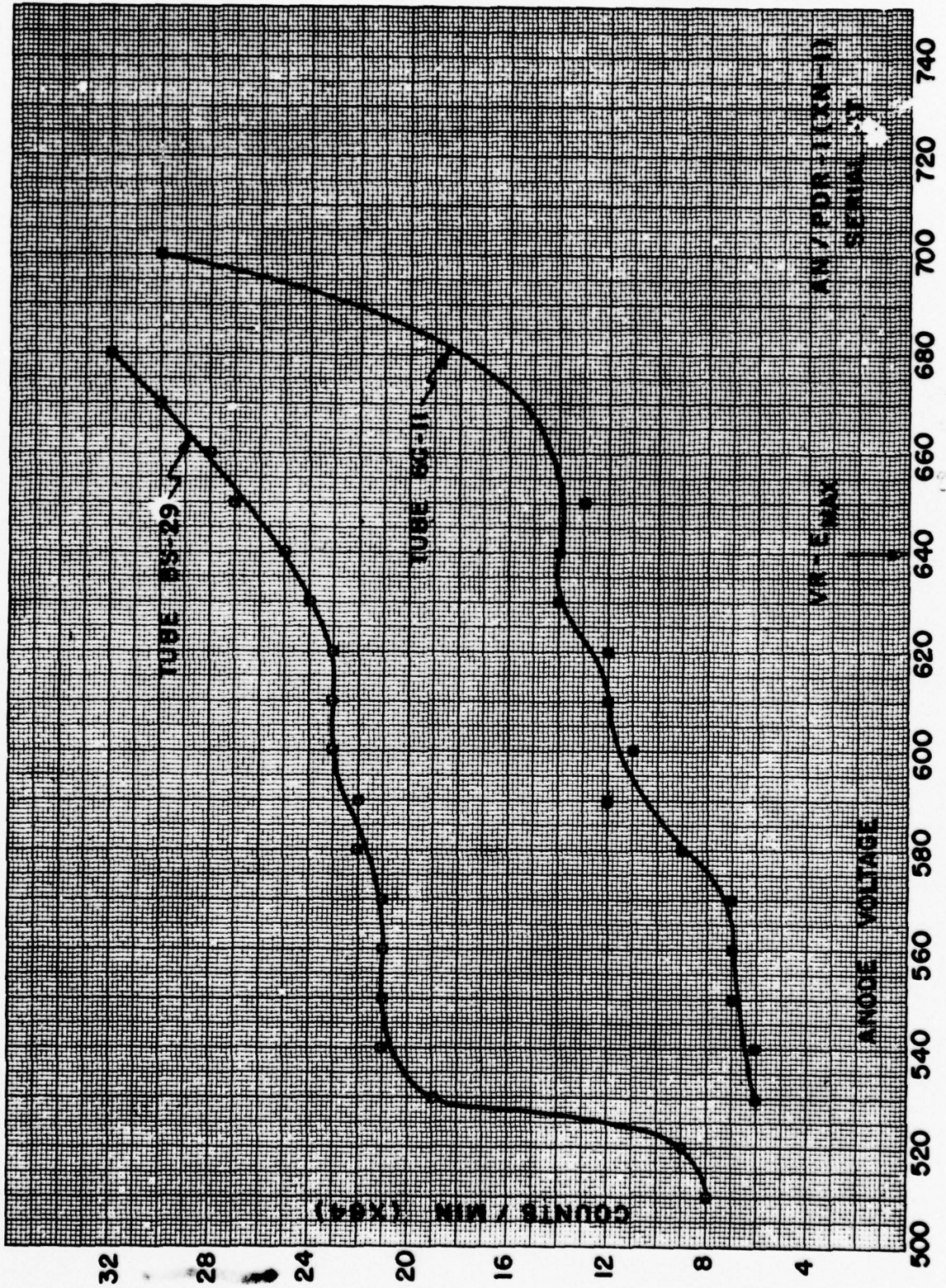

UNCLASSIFIED

- 37 -
Chart 8

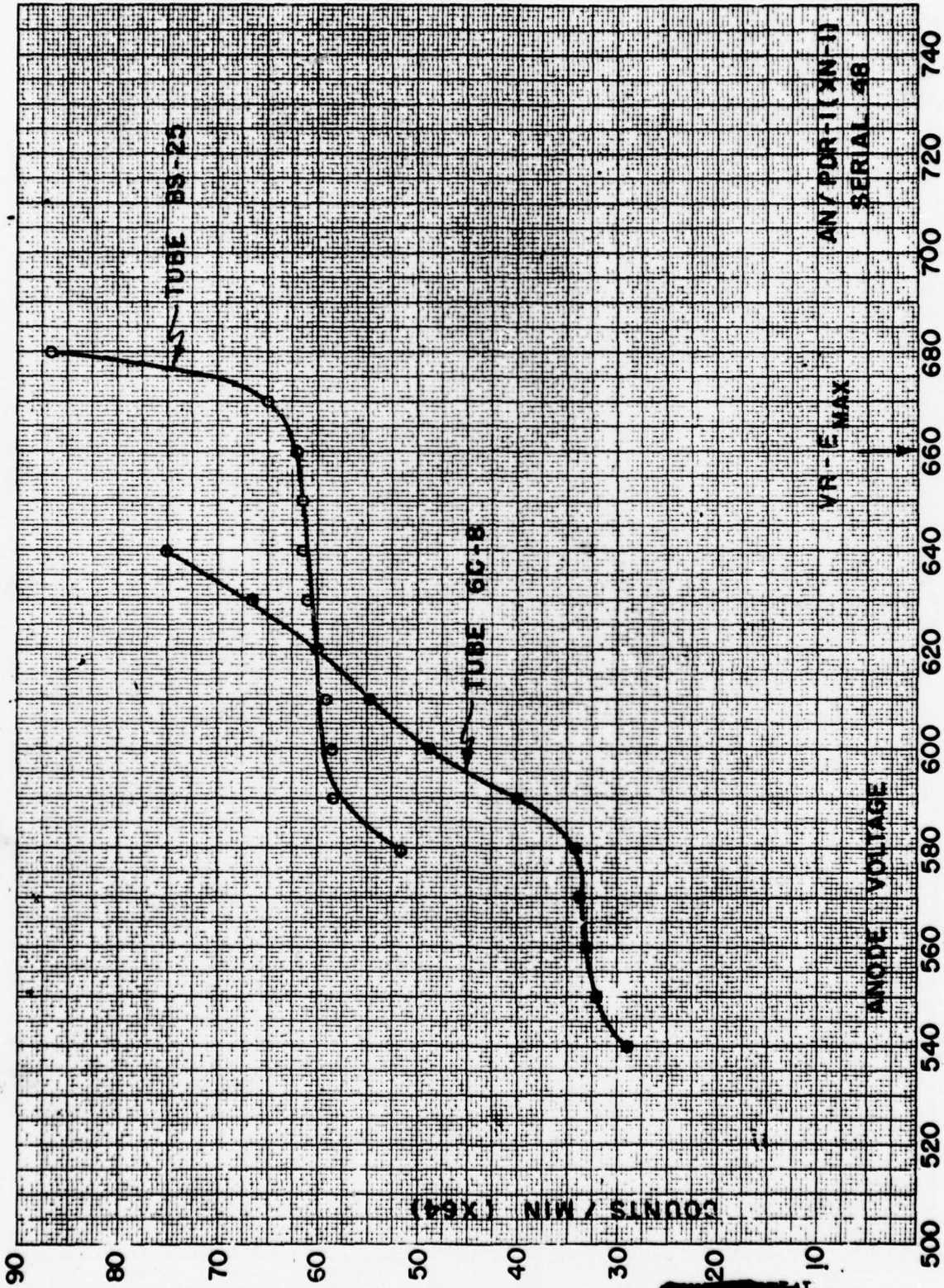

AN/PDR-1 (XN-1)
SERIAL 48

VR - E MAX

ANODE VOLTAGE

COUNTS / MIN (X64)

UNCLASSIFIED

UNCLASSIFIED

Chart 9³⁸ -

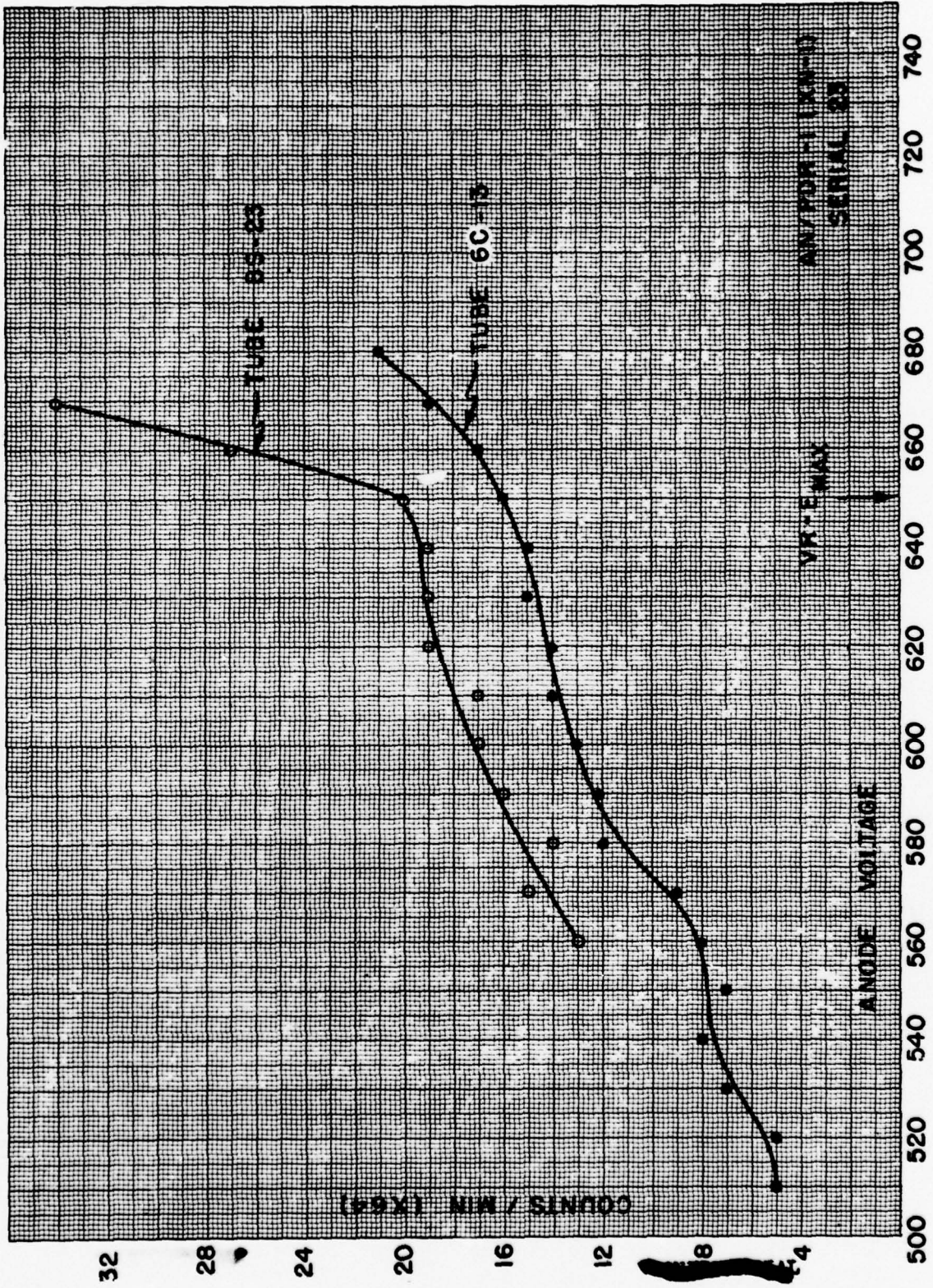

UNCLASSIFIED

UNCLASSIFIED

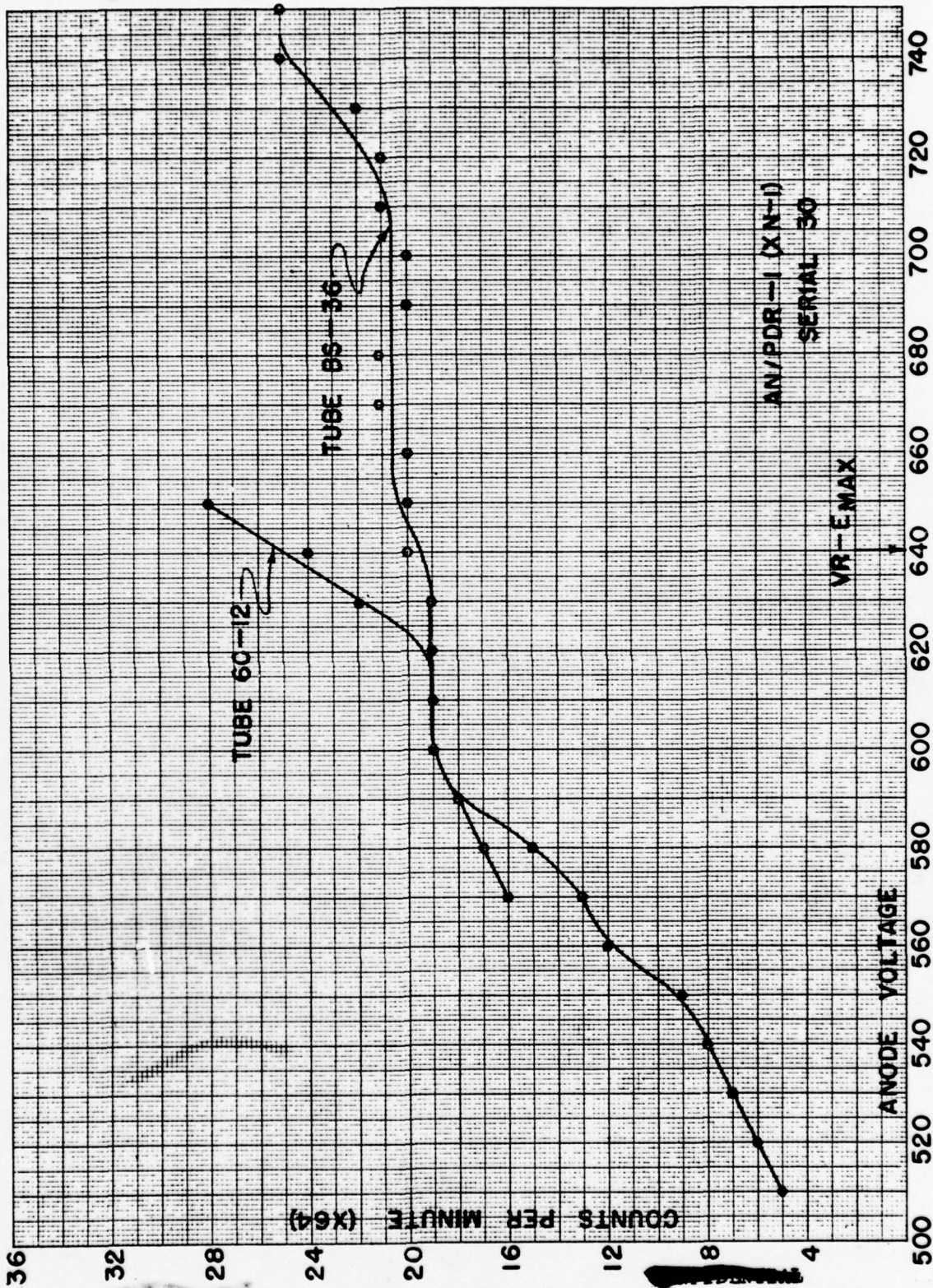

UNCLASSIFIED

UNCLASSIFIED

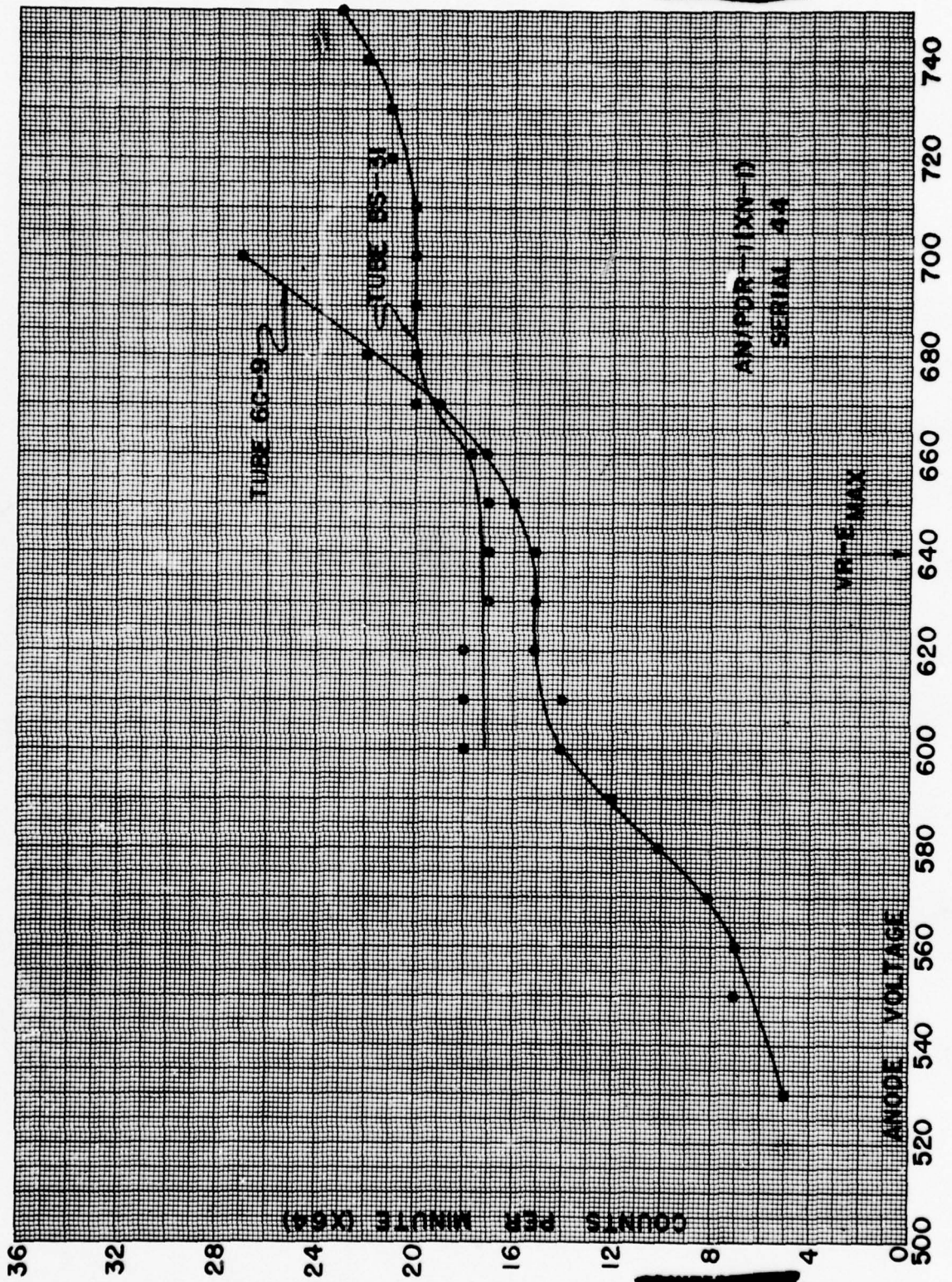

UNCLASSIFIED

~~CONFIDENTIAL~~

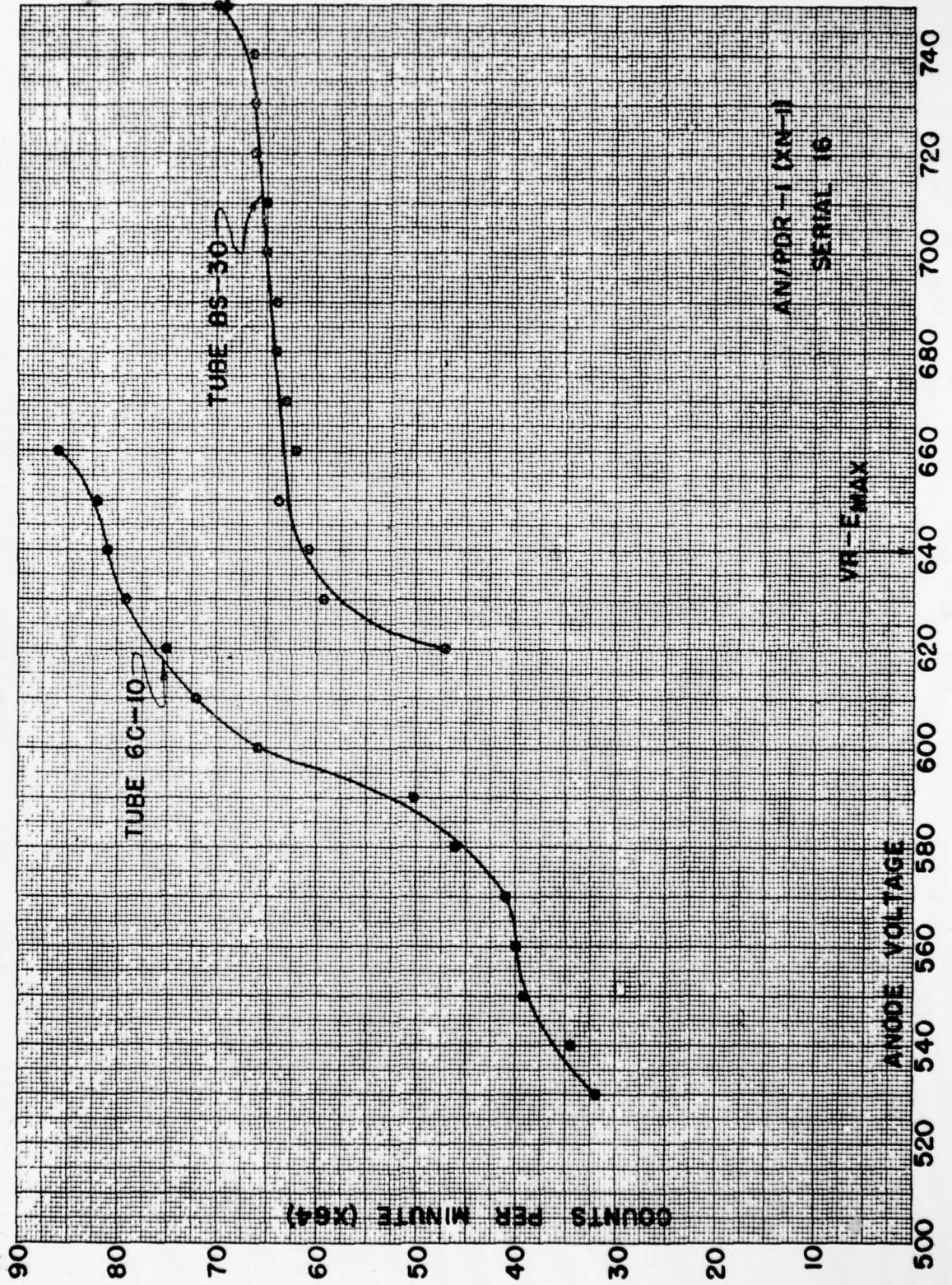

UNCLASSIFIED

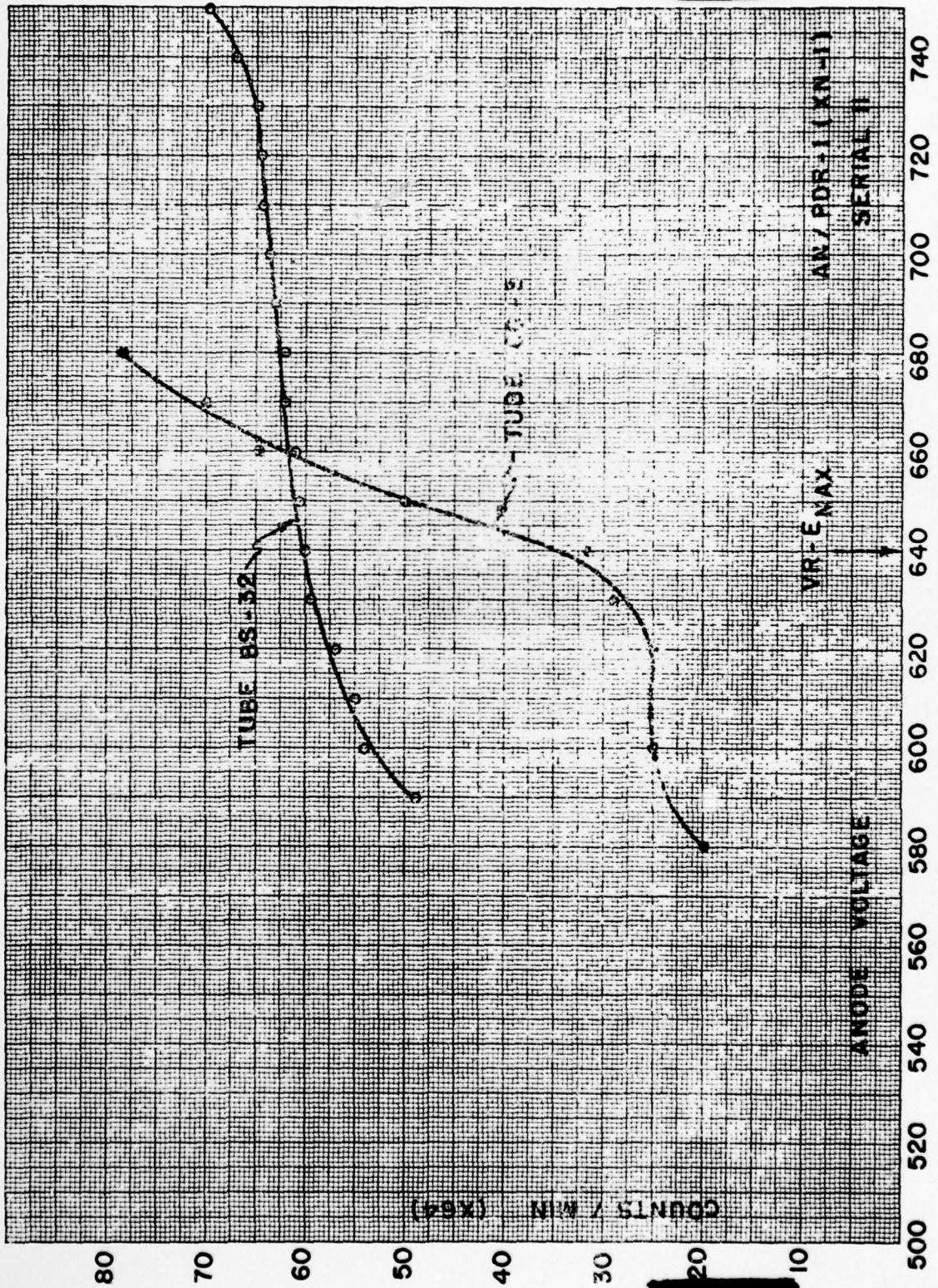

UNCLASSIFIED

~~CONFIDENTIAL~~

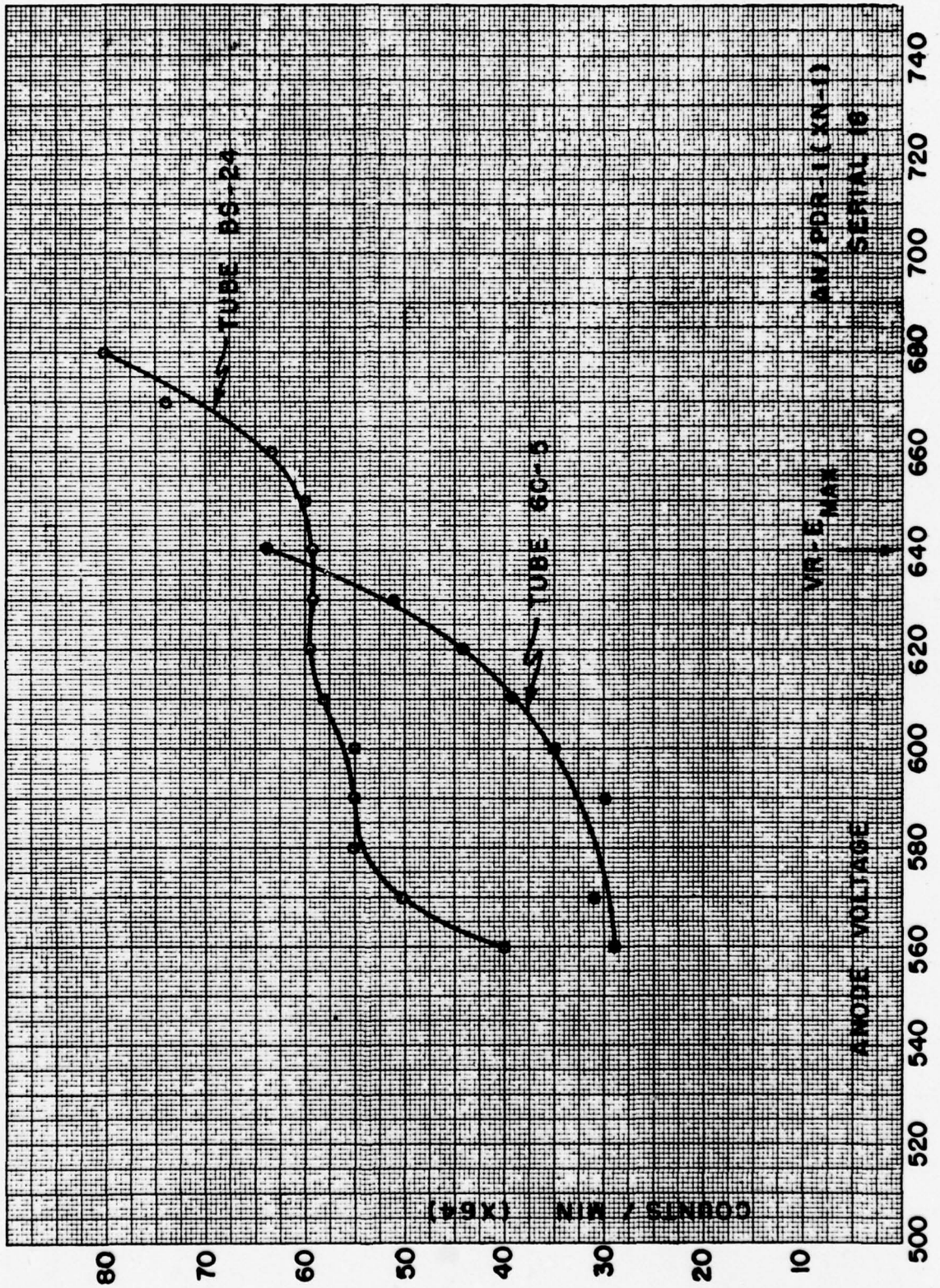

AN/PDR-1 (XN-1)
SERIAL 16

VR-E MAX

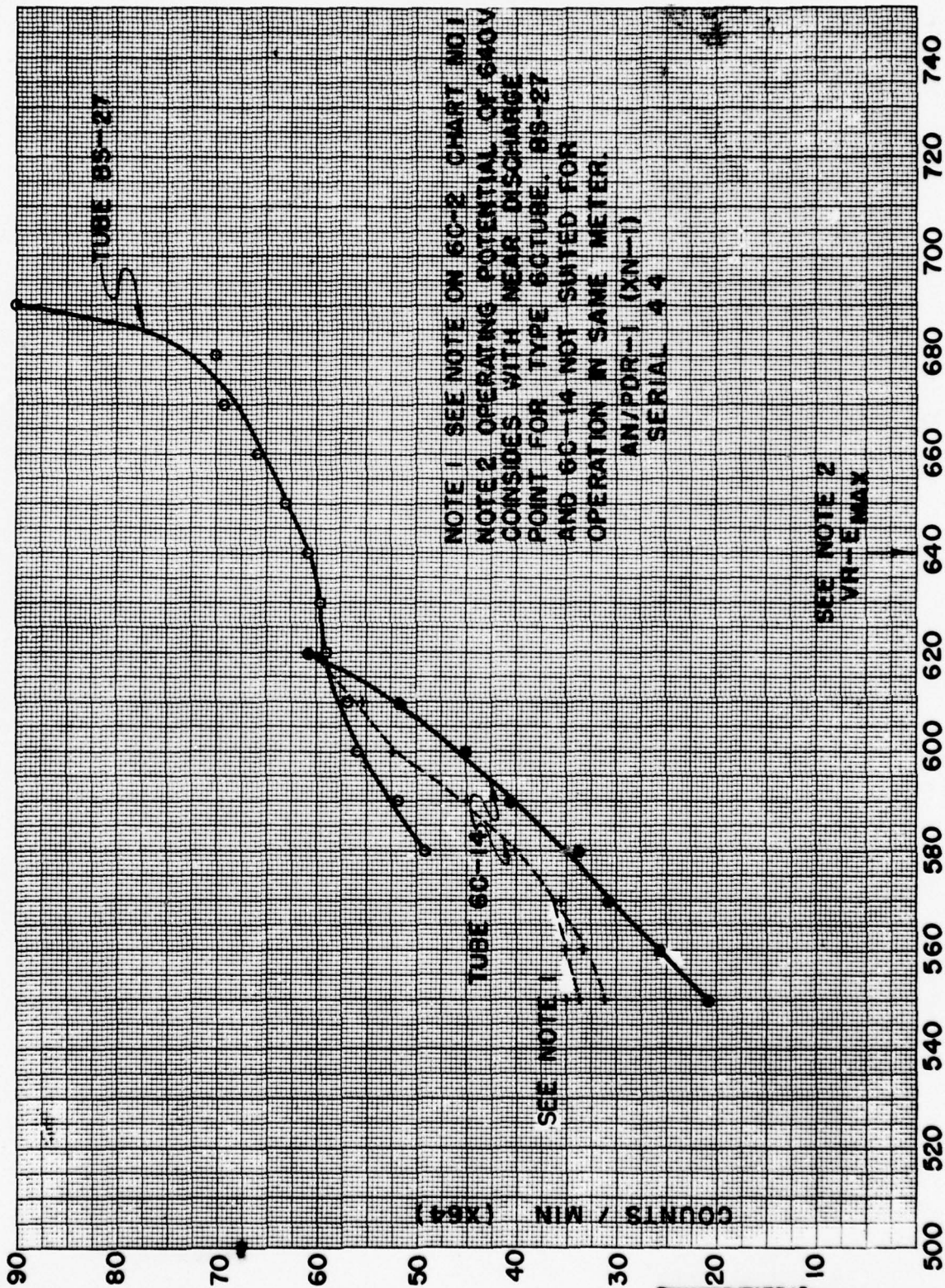

UNCLASSIFIED

~~CONFIDENTIAL~~

CHART NO. 16

GM and VR tube history and placement data

PDR-1 Ser. No.	VR tube No.	Emax	6C No.	BS No.	Remarks
8	20	640	6	26	
44	16	640	12	*31	*Broken in handling-mica window collapsed.
23	22	650	13	23	
16	9	640	*10	30	*End life reached in service.
30	7	640	9	36	
47	26	640	11	29	
48	18	660	8	25	
38	*13	640	15	28	*Cracked envelope-NG.
36	21	650	7	22	
34	24	640	*1	34	*Cracked envelope near cathode seal.
18	23	640	5	24	
12	12	640	14	*37	*Broken in installation at anode connection seal.
3	25	620	2	35	
11	15	640	3	32	
25	none	450	10-57	A-11	
Spare	+14	none	*4	*33	*Broken during handling. +No control on receipt.
PDR-8	460	450	5-15	*A-11	*Failed in service.

Note: GM tubes have been removed from their respective meters for further I and E tests and for additional plateau studies except in the case of PDR-1, Ser. No. 30 and PDR-8 both of which are in operating condition and to be used in future field surveys.

~~CONFIDENTIAL~~
UNCLASSIFIED

CHART 17

Table of comparisons of GM Tube current and voltage characteristics.

<u>TYPE</u>	<u>Current</u>	<u>Voltage</u>	<u>Applied E</u>
BS # 23	5 uA	15	645
29	13	54	"
34	3	10	"
32	3	9	"
35	2.5	7	"
30	0.5	3	"
6C # 14	1 uA	39	645
12	3	69	"
11	3	69	"
3	0.75	32	"
2	2	74	"
VG-13	1.5	3	945
HS Martin	3	7	"

RCL-MK1, Mod. 20B Leakage across base of tube-not satisfactory

FIGURE 2- Circuit For Determining E and I Values

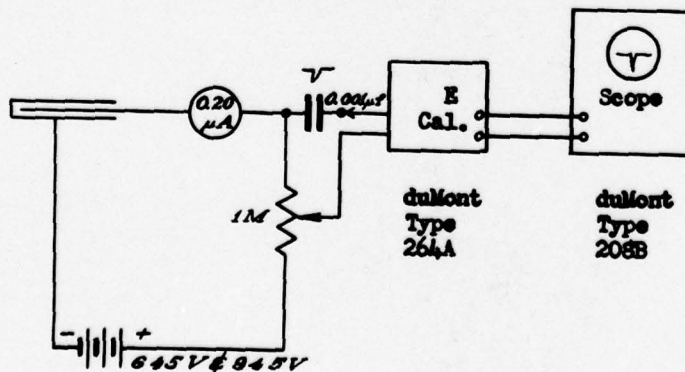

CHART No. 12

Battery complement for Model PDR-1

<u>TYPE</u>	<u>E Rating</u>	<u>I Drain</u>	<u>Use in Circuit</u>
EV. #467 (2)	67.5 v.	8 MA	Two in series for osc. plate supply in RF power supply.
Burg. #4F (1)	1.5 v.	150 MA	All filaments
EV. #412 (1)	22.5 v.	0.2 MA	Plate supply for (2) type CK570AX triodes in electrometer circuit.
Burg. #2 (2)	1.5 v.	Negligible	Bias supply to electrometer tubes.

Note 1- Weight of existing batteries combined equals 3 pounds, ± 2 ounces.

Weight of batteries required to supply all power direct is equal to 2.5 pounds ± 2 ounces. The space requirement will be approximately the same for both.

The latter provision for supplying power contemplates the use of EV. #493, 300 v. batteries for the GM tubes; (1) EV. #412, 22.5 v. battery for electrometer tube B+; (2) Mallory Bias cells, and (2) Mallory type RMB mercury cells in parallel for filament supply to electrometer tubes. It is noted that in the existing circuit the RF Osc. power supply tube requires approximately 4/5 of the current used in the filament circuit.

UNCLASSIFIED

Chart 19

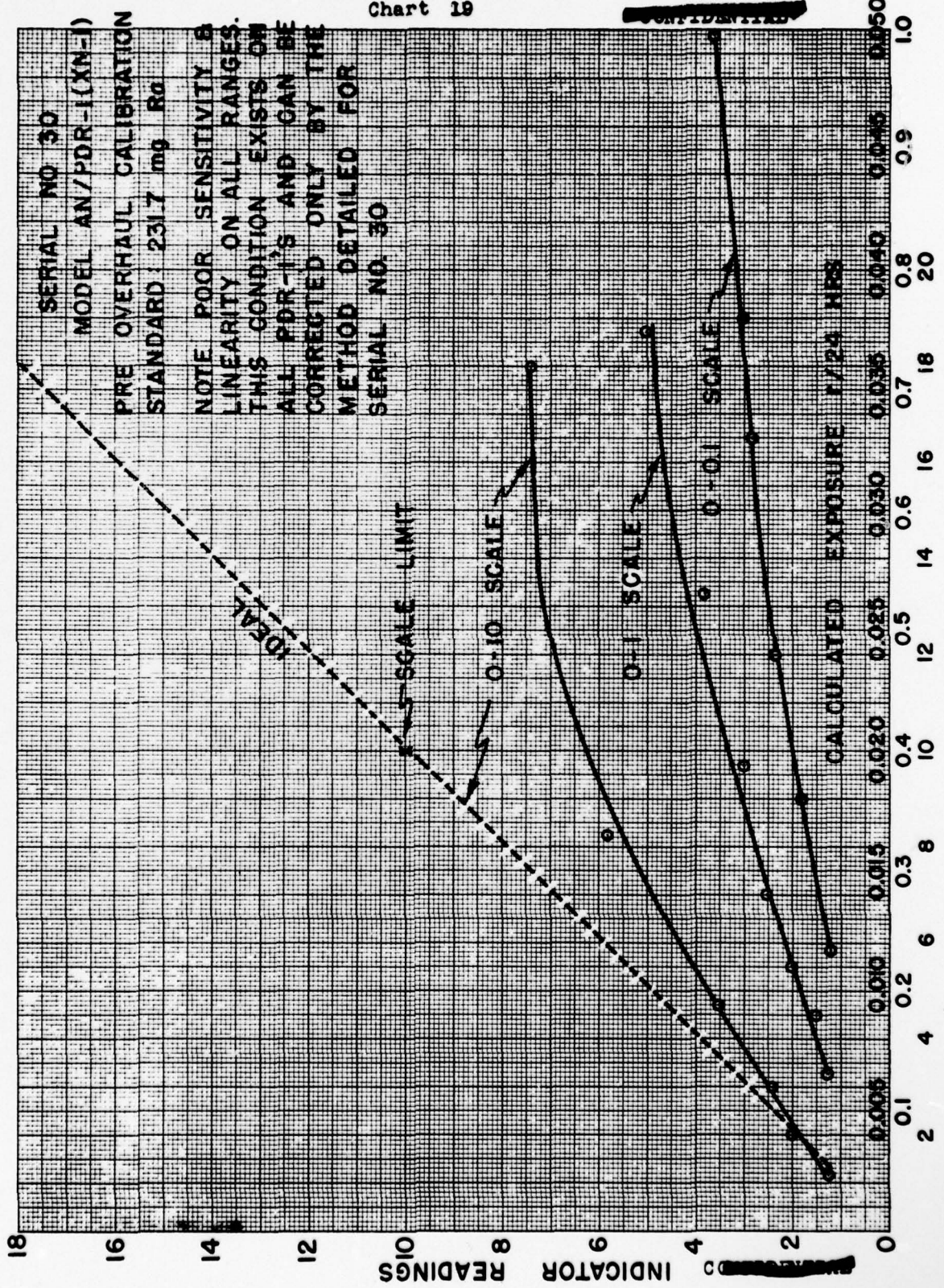

UNCLASSIFIED

UNCLASSIFIED

Chart 49-20

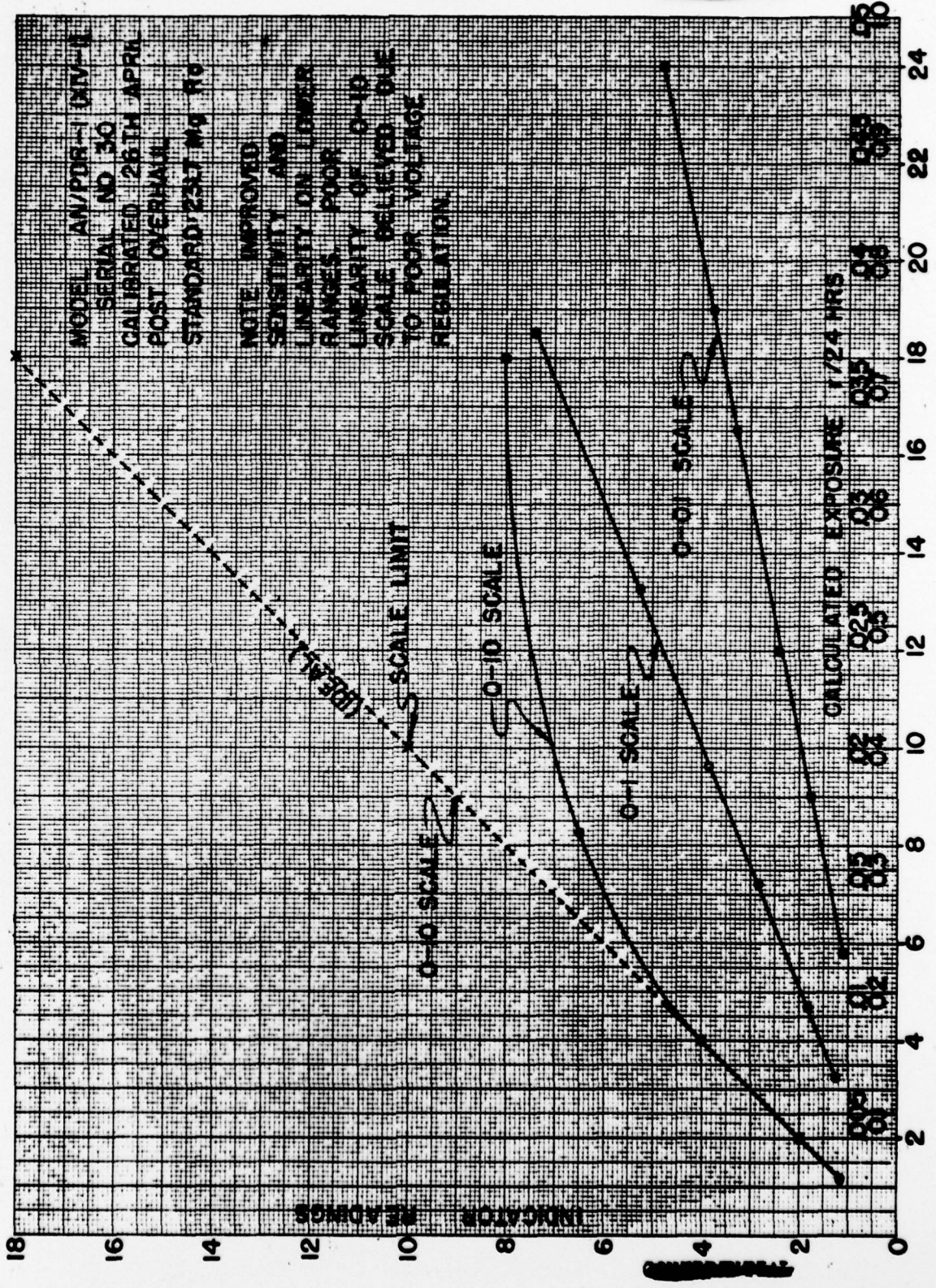

UNCLASSIFIED

UNCLASSIFIED

Chart 50 21

MODEL AN/PDR-11XN-11
SERIAL NO. 30

DRIED & SEALED WITH
SILICA-GEL INCLOSED - NOT
RECALIBRATED AFTER THAT
OF CHART 20. NOTE INCREASE
IN SENSITIVITY AND IMPROVED
LINEARITY REMAINS NON-
LINEAR ON LOG-SEN SCALE,
SAMPLE - SAME AS FOR CH 20

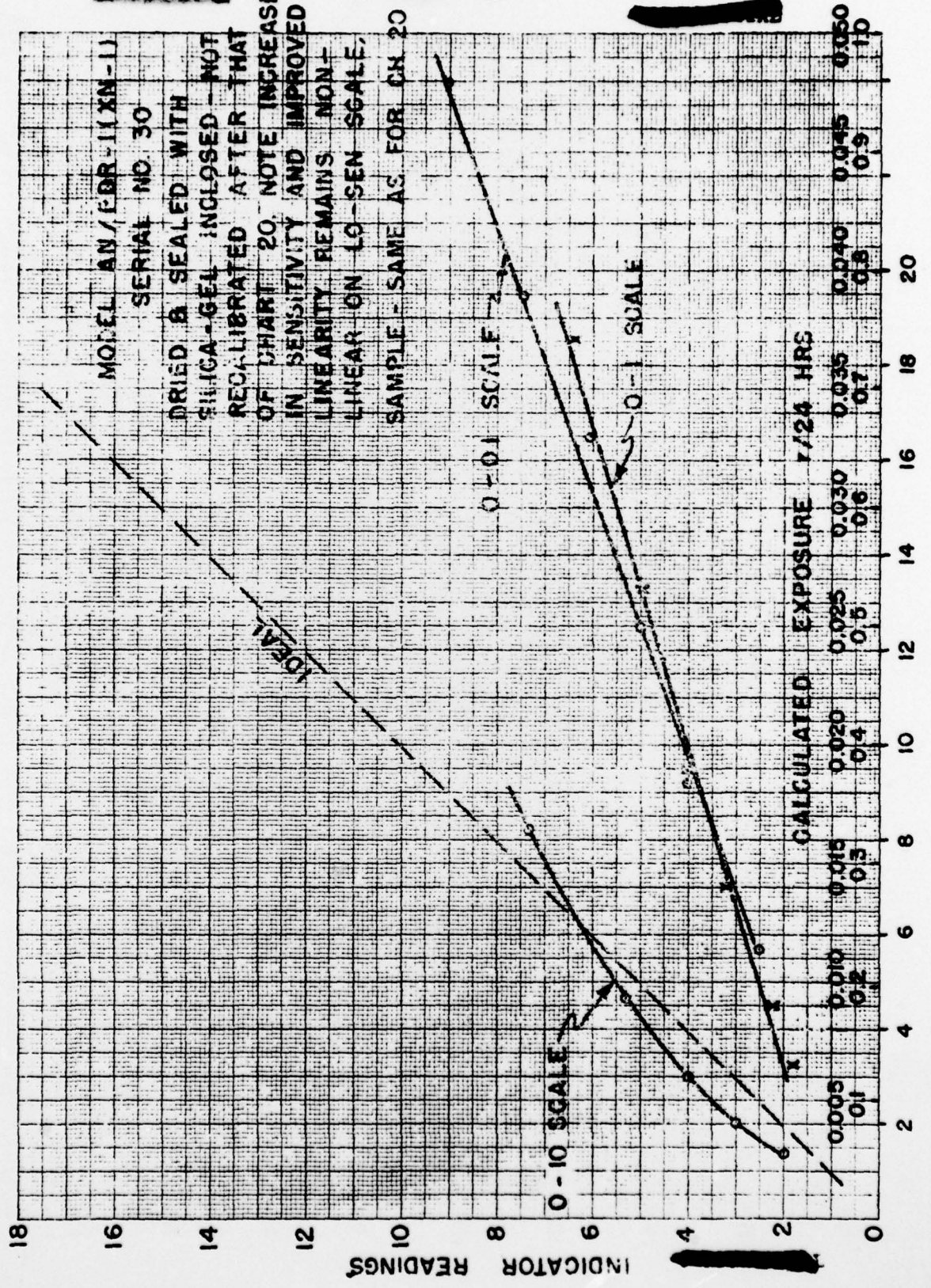

UNCL.

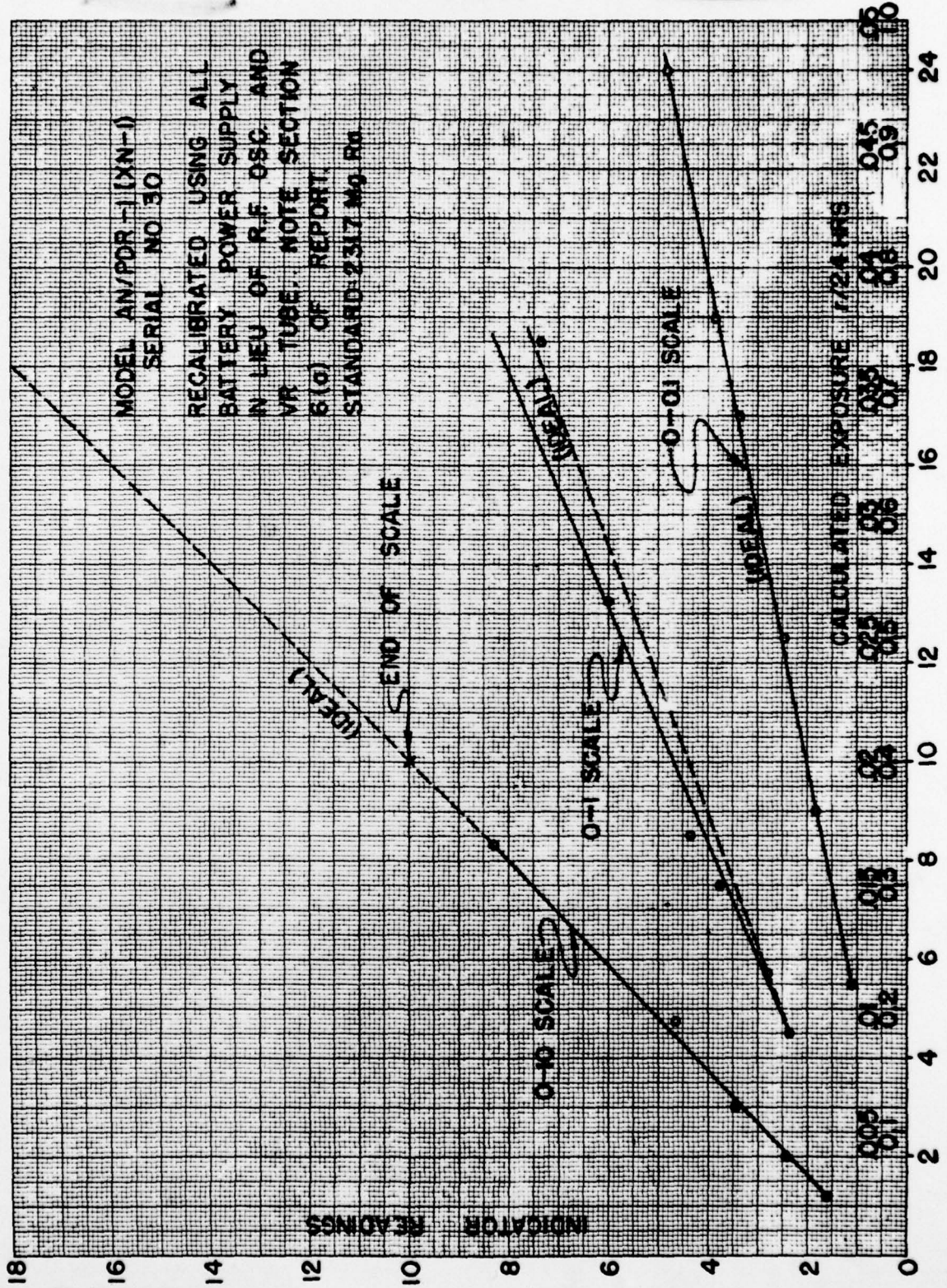

UNCLASSIFIED

- 52 -
Chart 23

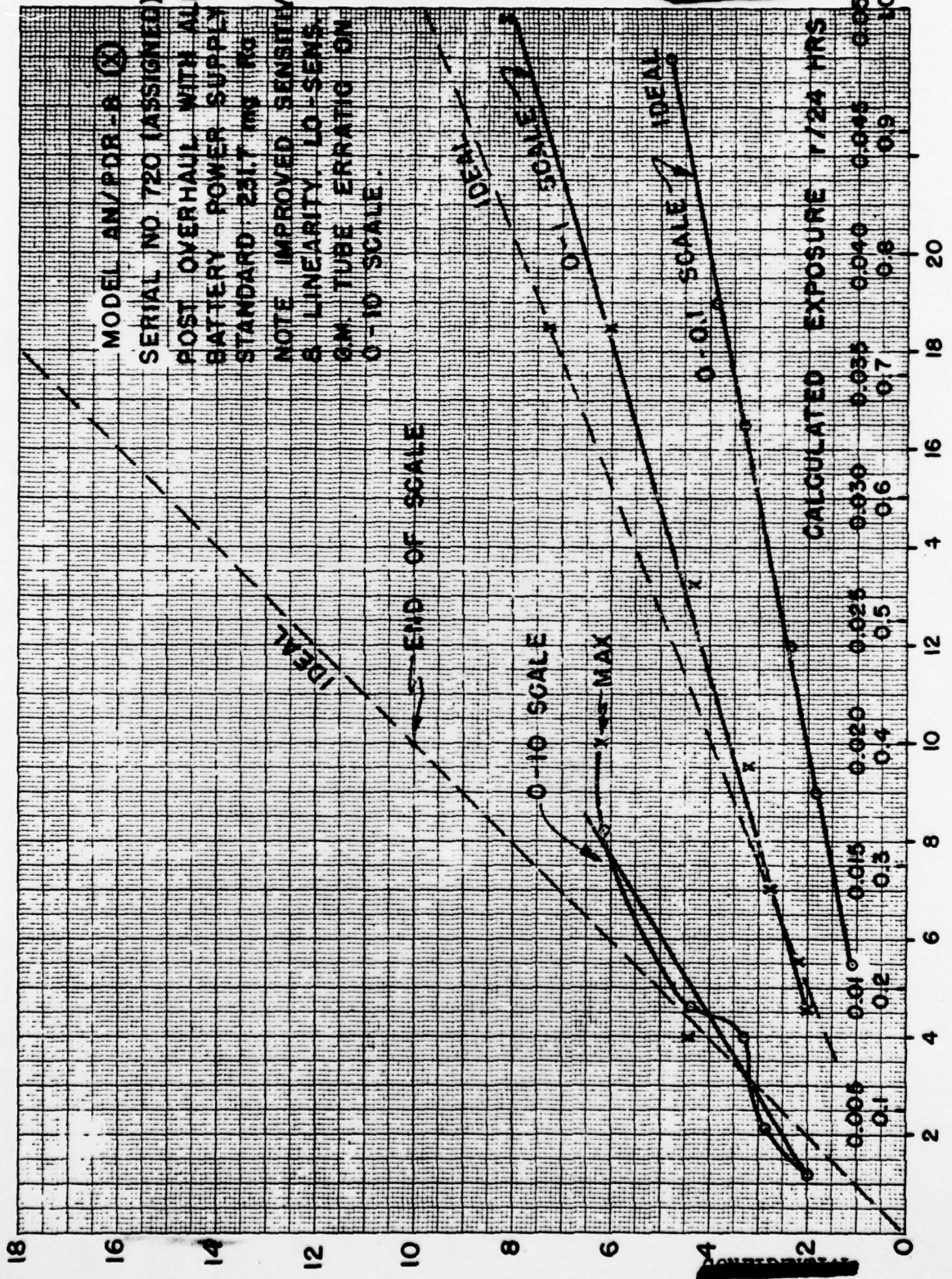

UNCLASSIFIED

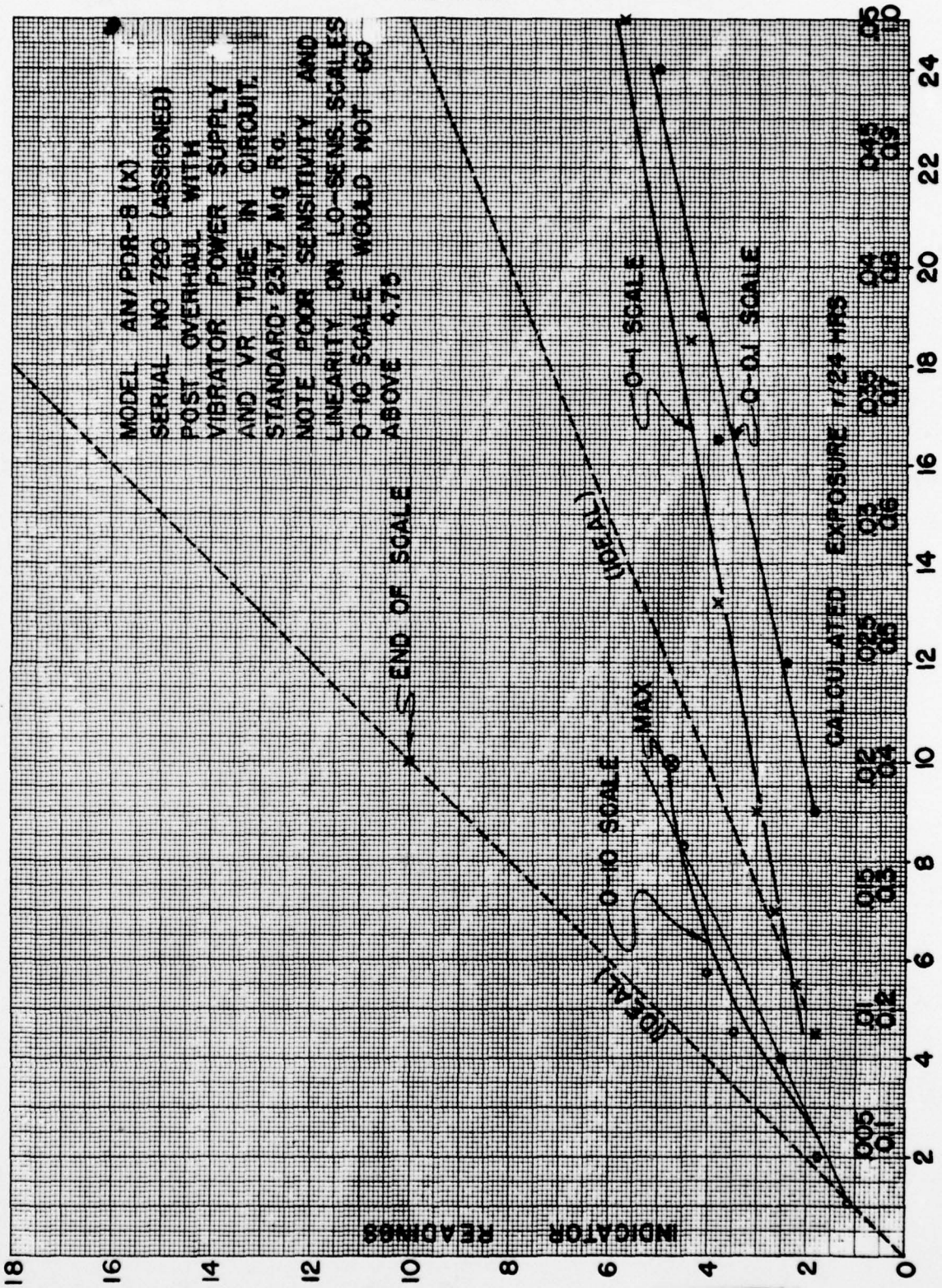

UNCLASSIFIED

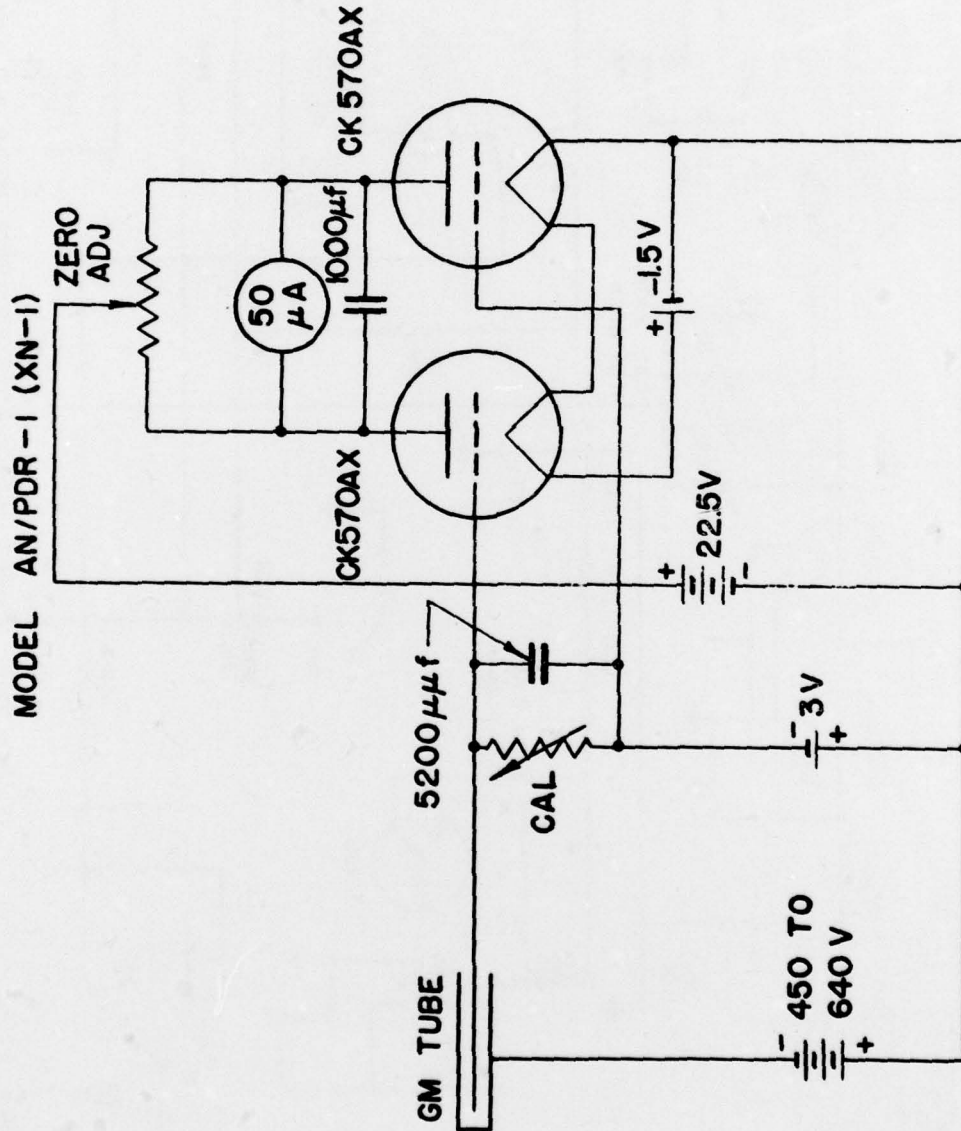

FIG 1

MODEL PDR-1 BASIC CIRCUIT SHOWING A BALANCED TYPE OF DIRECT CURRENT AMPLIFIER

UNCLASSIFIED

CONFIDENTIAL

UNCLASSIFIED

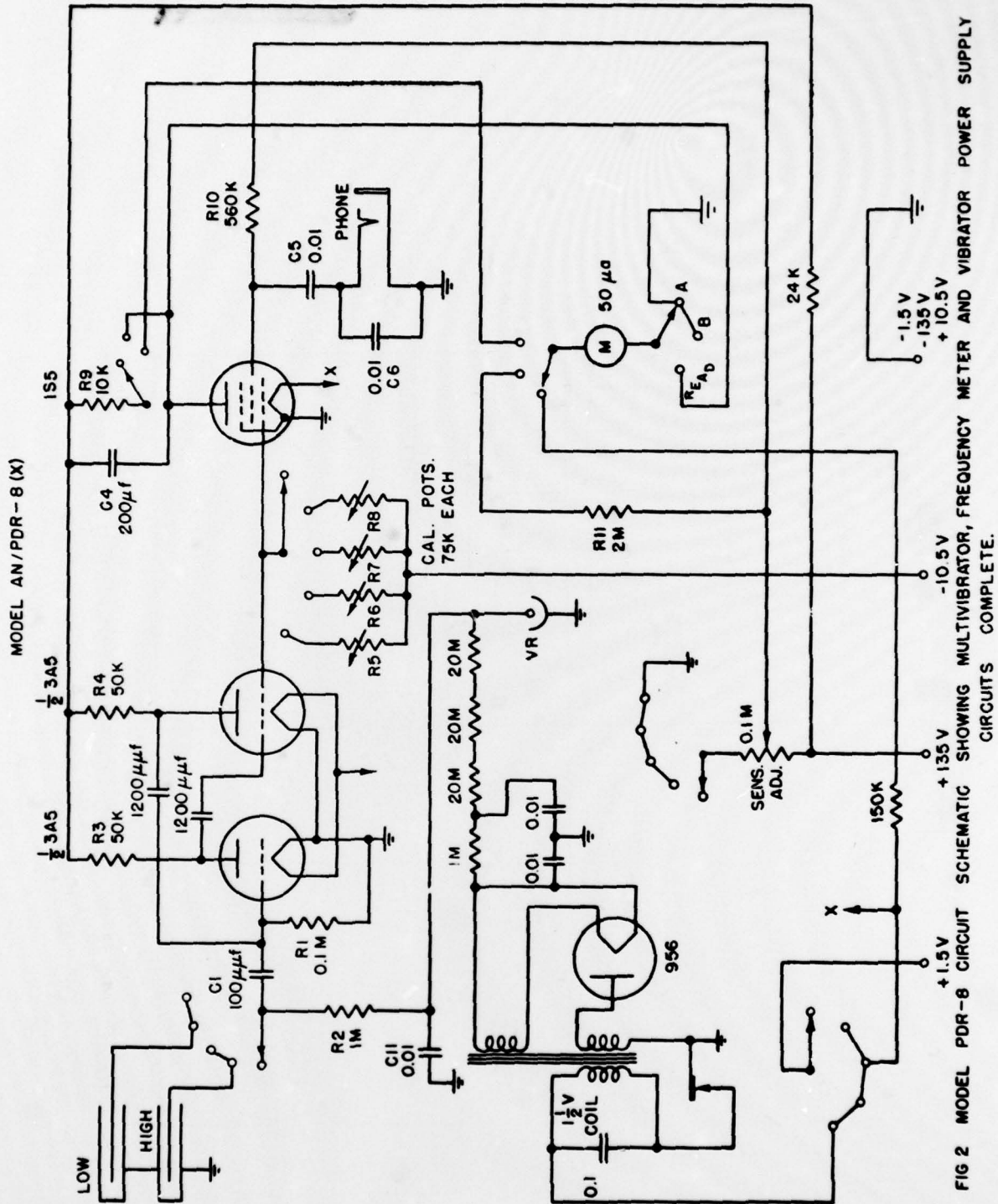

FIG 2 MODEL PDR-8 CIRCUIT SCHEMATIC SHOWING MULTIVIBRATOR, FREQUENCY METER AND VIBRATOR POWER SUPPLY CIRCUITS COMPLETE.

~~CONFIDENTIAL~~

CORONA DISCHARGE TYPE VR TUBE

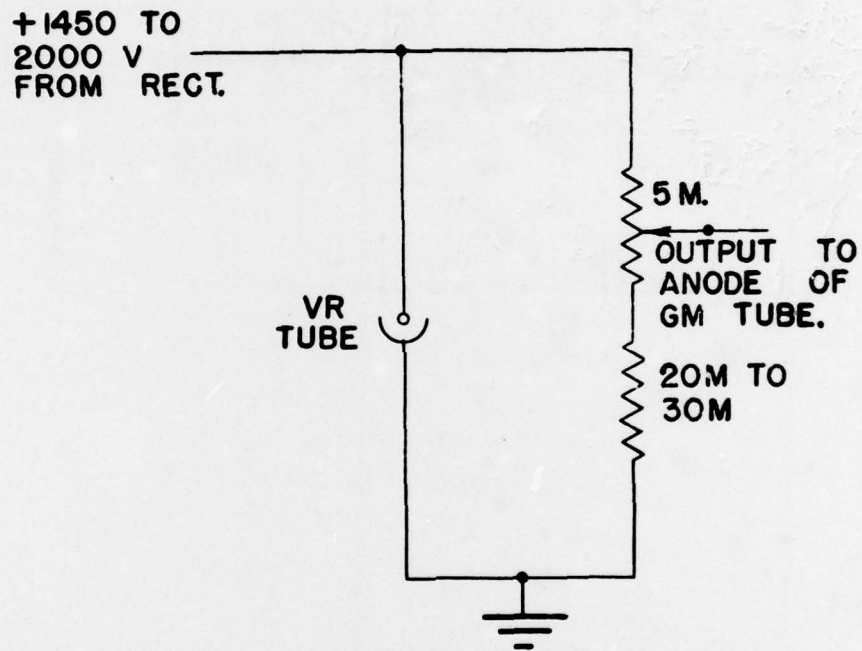
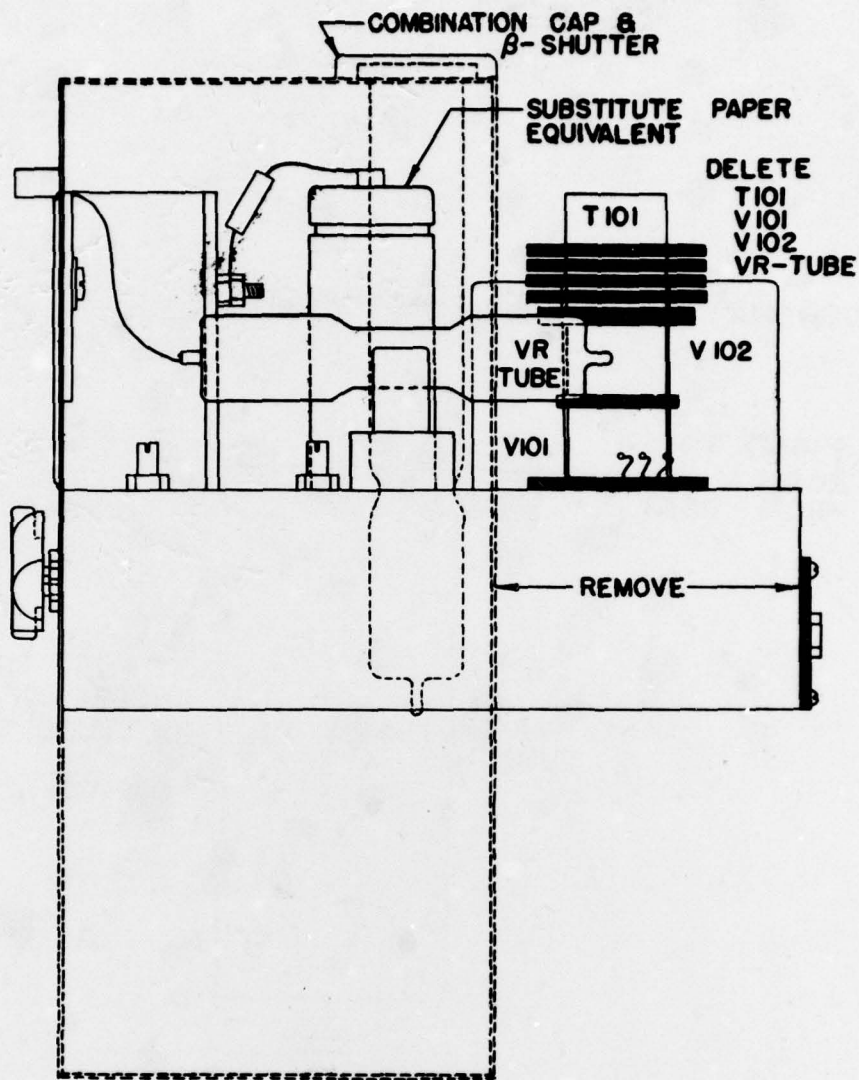

FIG 3

SUGGESTED CIRCUIT FOR LOWERING THE CONTROL VOLTAGE POINT OF A CORONA DISCHARGE TYPE VR TUBE

UNCLASSIFIED



SIDE VIEW

FIG 4 SUGGESTED RE DESIGN OF MODEL PDR-1&8 CASE
DIMENSIONS: 9 1/2" L X 5 1/2" W X 4" H WEIGHT: 9 LBS (APPROX)

NOTE: HEAVY DOTTED LINES & FRONT PANEL OF EXISTING
DENOTE OUTLINE OF NEW

SEE FIG 7 FOR DETAILS OF CARRYING HANDLE

UNCLASSIFIED

~~CONFIDENTIAL~~

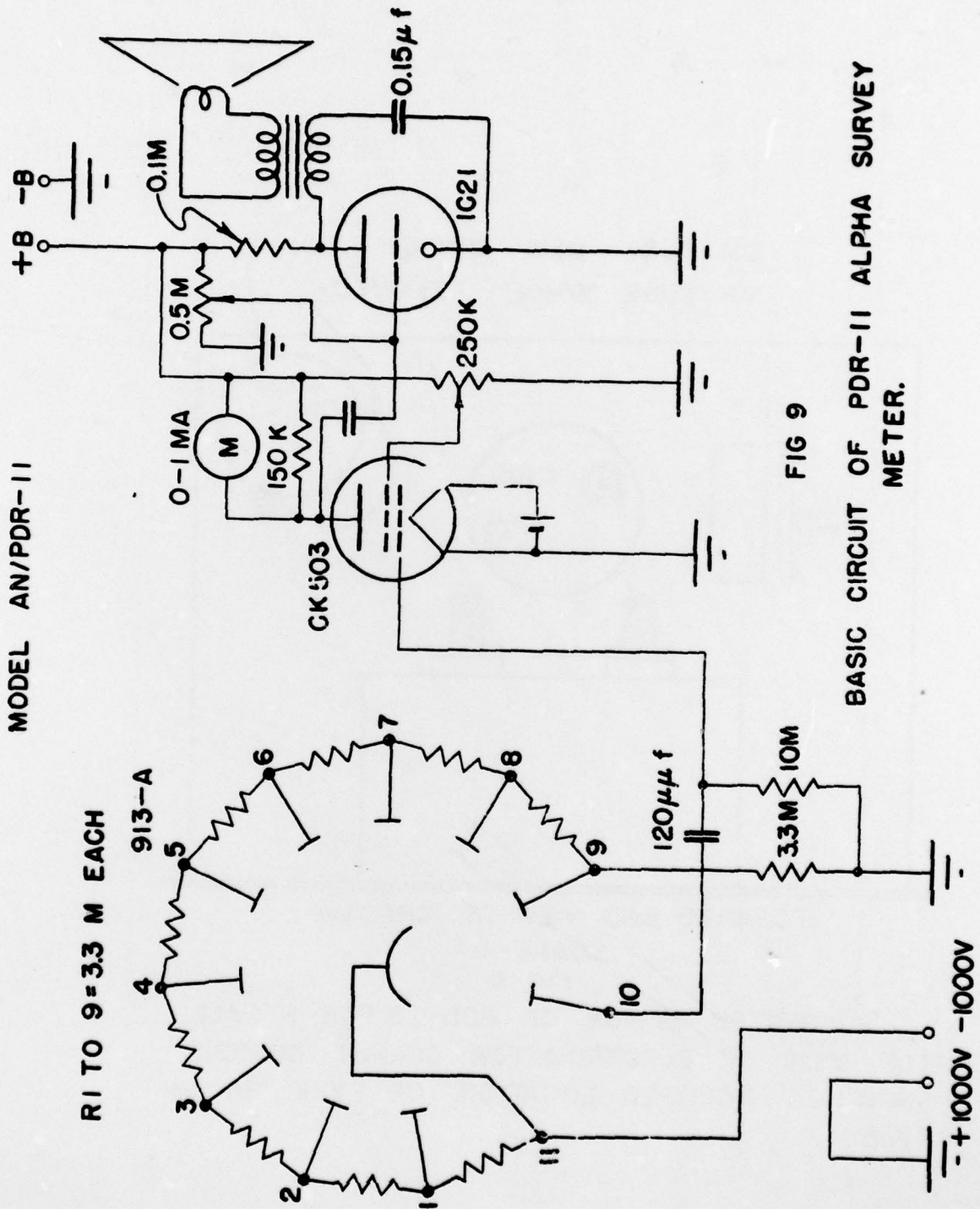

GM TUBE - MICA WINDOW END
VR TUBE MOUNT REMOVED

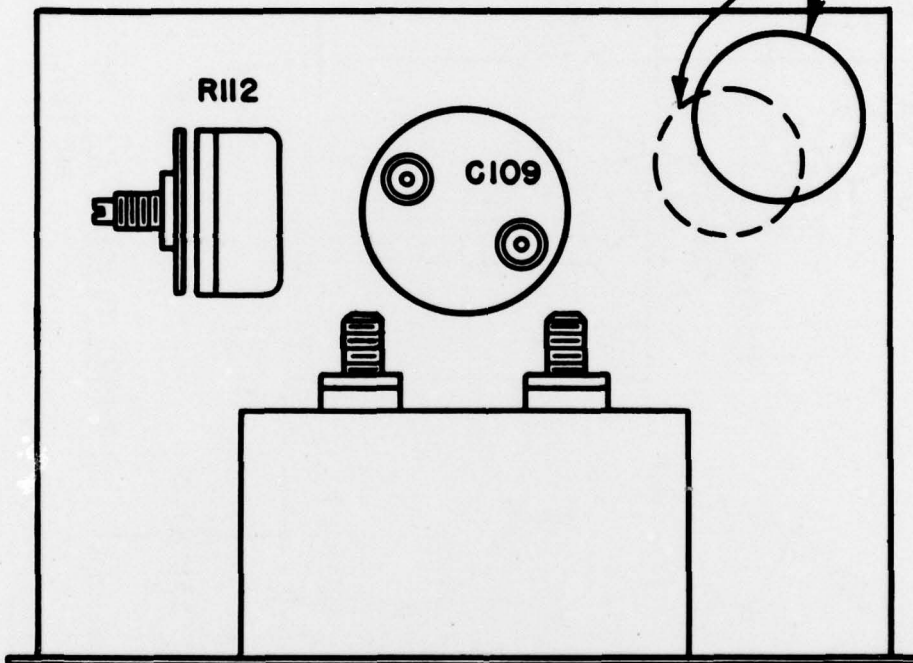

FORWARD END VIEW OF CHASSIS

SCALE = 1:1

FIG 5

SUGGESTED DESIGN OF PDR-1 & PDR-8 CASE.
TOP VIEW OF ELECTROMETER CIRCUIT CHASSIS
SHOWING PROPOSED LOCATION OF TYPE BS GM
TUBE.

UNCLASSIFIED

~~CONFIDENTIAL~~

- 60 -

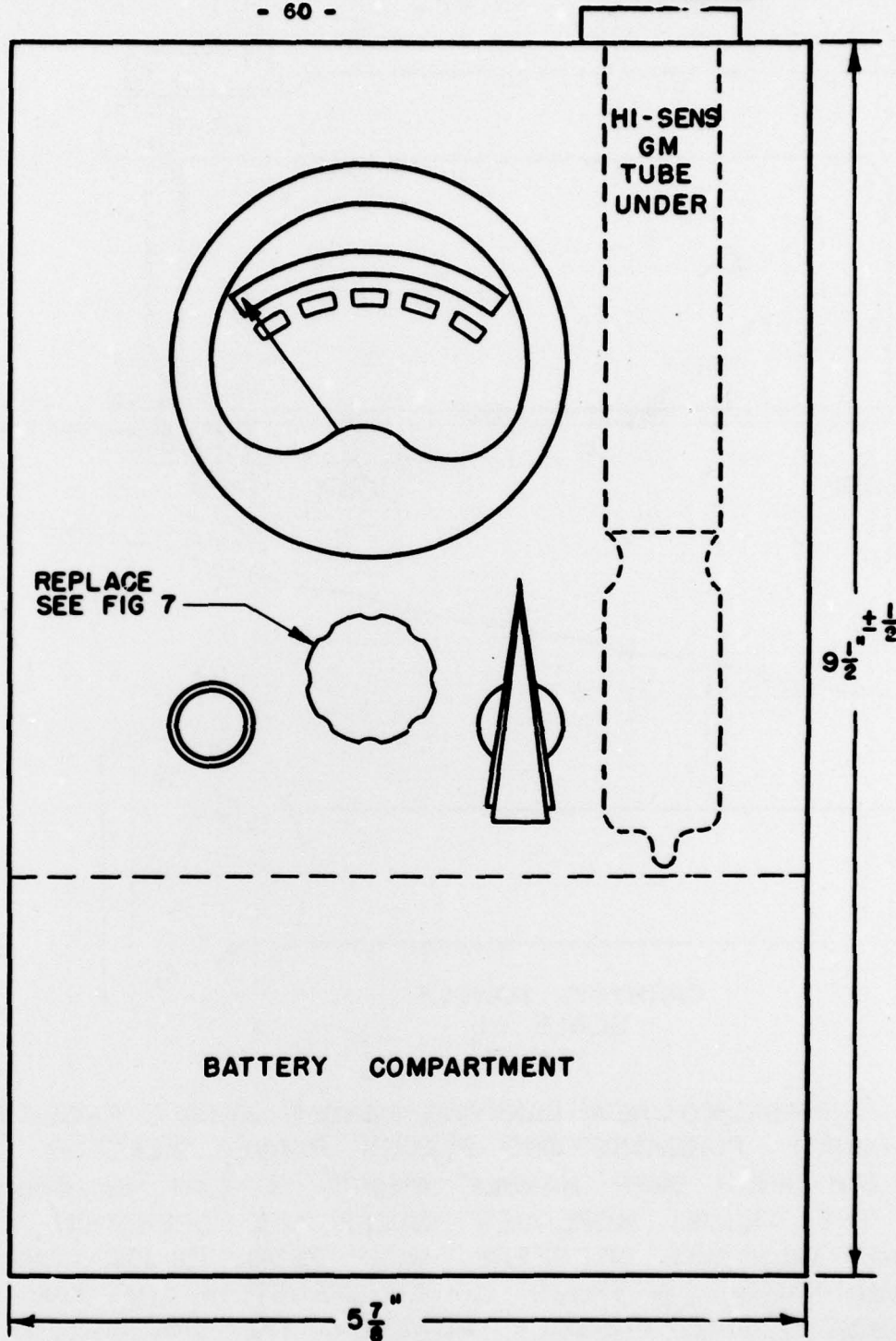

$9\frac{1}{2}$ "

REPLACE
SEE FIG 7

HI-SENS
GM
TUBE
UNDER

BATTERY COMPARTMENT

$5\frac{7}{8}$ "

SCALE = 1:1

FIG 6

TOP OF METER AS IT WILL APPEAR WITH ADDITION
OF POWER SUPPLY OR BATTERY COMPARTMENT

UNCLASSIFIED

- 61 -

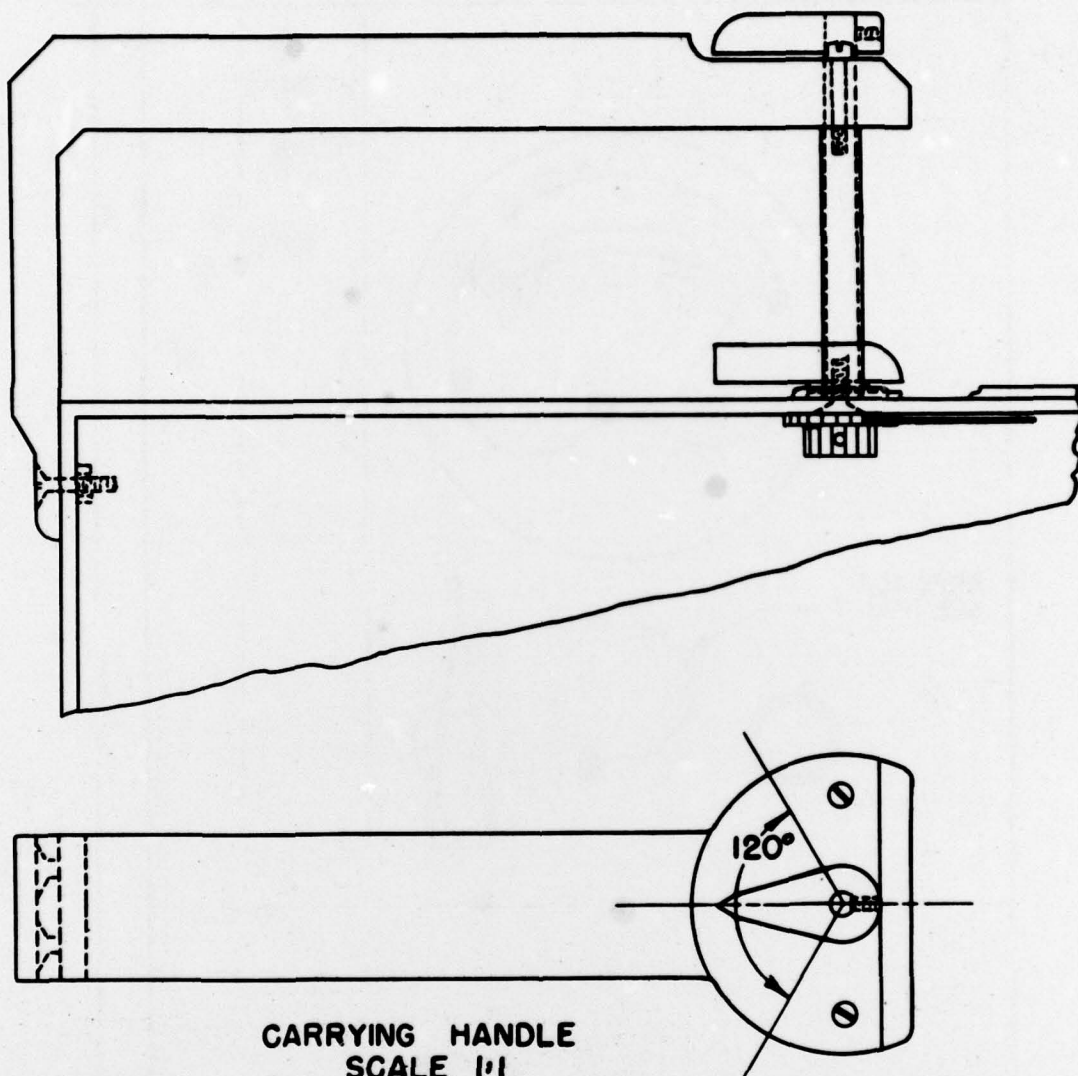

CARRYING HANDLE
SCALE 1/1
FIG 7

PROPOSED NEW CARRYING HANDLE ARR'G'T. PROVIDES ADEQUATE PURCHASE AND PLACES RANGE SELECTOR SWITCH KNOB OVER HANDLE WHERE IT CAN BE OPERATED BY THE THUMB; MOREOVER WHERE THE OPERATION OF SAME WILL NOT INTERFERE WITH ZERO ADJUST CONTROL KNOB. VARIOUS METHODS OF CONSTRUCTION OF THE FW'D PEDESTAL ARE POSSIBLE HOWEVER THE ONE SHOWN PERMITS READY REMOVAL OF HANDLE IN CASE IT BECOMES CONTAMINATED. METAL HANDLE AND CONTROL KNOB RECOMMENDED WITH SMOOTH FINISH ON BOTH.

~~CONFIDENTIAL~~
UNCLASSIFIED
~~CONFIDENTIAL~~

- 62 -

REDUCE LENGTH OF SPACERS TO PERMIT
HORIZONTAL MOUNTING OF TB ALSO MAKES
TUBES VERTICAL WHEN IN NORMAL USE.

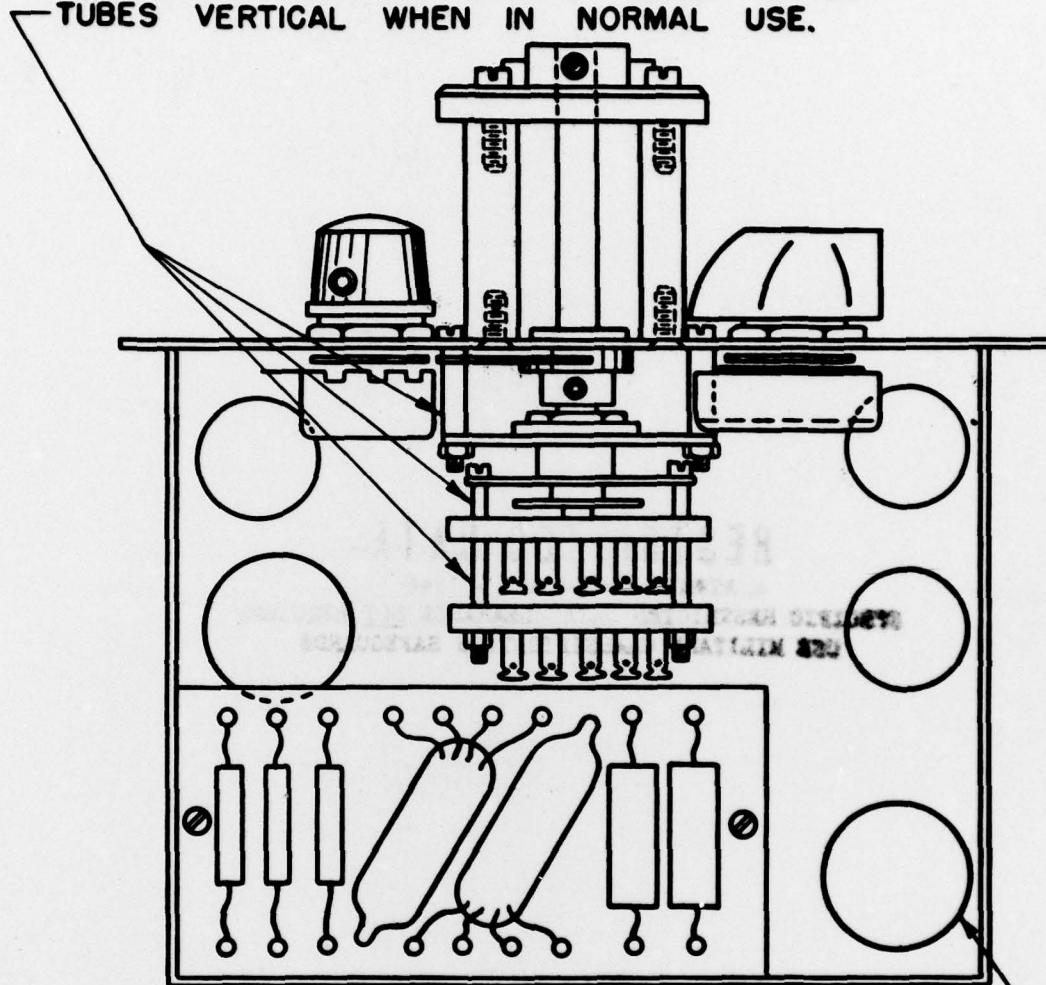

HOLE FOR GM TUBE
TYPE BS

ELECTROMETER CHASSIS
SCALE = 1:1
FIG 8

BOTTOM VIEW OF CHASSIS SHOWING
RELOCATION OF TERMINAL BOARD WITH EXISTING
COMPONENTS, AND FWD VIEW OF CARRYING
HANDLE MOUNT AS REVISED.

UNCLASSIFIED
~~CONFIDENTIAL~~