

AD-A078 564

NAVAL MEDICAL RESEARCH INST BETHESDA MD  
OPERATION SNAPPER, NEVADA PROVING GROUNDS, APRIL-JUNE 1952, PRO--ETC(U)  
DEC 52 R H DRAEGER , M EICHER , T S ELY

F/G 18/3

JNCLASSIFIED

AEC-WT-527

NL

| OF |

AD  
AD 78564



END  
DATE  
FILMED  
1-80  
DDC

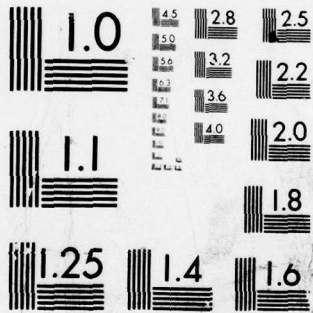

MICROCOPY RESOLUTION TEST CHART  
NATIONAL BUREAU OF STANDARDS-1963-A

PHOTOGRAPH THIS SHEET

AD-A078524

DTIC ACCESSION NUMBER



LEVEL



INVENTORY

AEC

WT-527

DOCUMENT IDENTIFICATION

**DISTRIBUTION STATEMENT A**

Approved for public release;  
Distribution Unlimited

DISTRIBUTION STATEMENT

ACCESSION FOR	
NTIS	GRA&I <input checked="" type="checkbox"/>
DTIC	TAB <input type="checkbox"/>
UNANNOUNCED	<input type="checkbox"/>
JUSTIFICATION	
Per Hr. on file	
BY	
DISTRIBUTION /	
AVAILABILITY CODES	
DIST	AVAIL AND/OR SPECIAL
A	

DISTRIBUTION STAMP

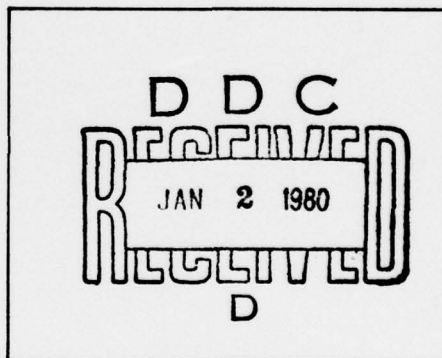

DATE ACCESSIONED

79 12 18 560

DATE RECEIVED IN DTIC

PHOTOGRAPH THIS SHEET AND RETURN TO DTIC-DDA-2

ADA078564

~~SECRET~~  
SECURITY INFORMATION

UNCLASSIFIED

This document contains information affecting the national defense of the United States within the meaning of the Espionage Laws, Title 18, U.S.C. Sections 793 and 794, the transmission or the revelation of its contents in any manner to an unauthorized person is prohibited by law.

~~SECRET~~  
SECURITY INFORMATION  
~~CANCELED~~

UNCLASSIFIED

 UNCLASSIFIED

This document consists of 81 pages  
No. 200 of 337 copies, Series A

OPERATION SNAPPER

Project 4.2

**BIOMEDICAL EXPOSURE EQUIPMENT**

*REPORT TO THE TEST DIRECTOR*

by

R. H. Draeger

M. Eicher

T. S. Ely

F. T. Harris

R. H. Lee

T. E. Shea

F. I. Whitten

December 1952

Naval Medical Research Institute  
National Naval Medical Center  
Bethesda, Maryland

   
UNCLASSIFIED

Reproduced Direct from Manuscript Copy by  
AEC Technical Information Service  
Oak Ridge, Tennessee

Inquiries relative to this report may be made to  
Chief, Armed Forces Special Weapons Project  
P. O. Box 2610  
Washington, D. C.

If this report is no longer needed, return to  
AEC Technical Information Service  
P. O. Box 401  
Oak Ridge, Tennessee

~~SECRET~~ UNCLASSIFIED

#### PREFACE

This publication describes and evaluates equipment designed for the exposure of animals and biological materials to certain effects of an atomic bomb explosion. In this sense the subject matter belongs in the same report, however, since there is considerable diversity in the effects considered, a single chapter has been devoted to each type of equipment.

The first chapter is concerned with exposure to direct air blast, the second deals with the production of flashburns, the third with exposure to ionizing radiation. Certain instruments are described in the fourth chapter which are applicable to more than one type of exposure equipment.

#### ACKNOWLEDGMENTS

The authors wish to acknowledge the valuable services of the following individuals to this project: A. C. Allen, J. S. Otto, N. J. Marbois, and T. P. Nordquist; and Miss Gertrude E. Brown for assistance in preparation of the report.

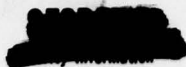

CONTENTS

PREFACE . . . . . 3

ACKNOWLEDGMENTS . . . . . 3

ILLUSTRATIONS . . . . . 7

TABLES . . . . . 9

CHAPTER 1 AIR BLAST EXPOSURE EQUIPMENT . . . . .

    1.1 Abstract . . . . . 11

    1.2 Objective . . . . . 11

    1.3 Introduction . . . . . 11

    1.4 Description of Equipment . . . . . 12

        1.4.1 Blast Barrier . . . . . 12

        1.4.2 Open Mesh Blast Exposure Cages . . . . . 12

        1.4.3 Cylindrical Blast Exposure Containers . . . . . 14

        1.4.4 Wooden Dog . . . . . 14

        1.4.5 Accelerometers . . . . . 15

        1.4.6 Peak Pressure Recorder . . . . . 17

        1.4.7 Pressure-time Recorders . . . . . 19

    1.5 Experimental Procedure . . . . . 22

    1.6 Results . . . . . 24

    1.7 Discussion . . . . . 28

    1.8 Conclusion . . . . . 30

CHAPTER 2 THERMAL EXPOSURE EQUIPMENT . . . . . 33

    2.1 Abstract . . . . . 33

    2.2 Objective . . . . . 33

    2.3 Introduction . . . . . 33

    2.4 Description of Equipment . . . . . 34

        2.4.1 Modification of Operation GREENHOUSE  
            Exposure Containers . . . . . 34

        2.4.2 Aperture Plates . . . . . 35

        2.4.3 Aperture Plate Timer . . . . . 36

        2.4.4 Animal Container . . . . . 38

        2.4.5 Ventilation and Housing . . . . . 38

        2.4.6 Batteries . . . . . 41

        2.4.7 A-frame Containers . . . . . 41

        2.4.8 Dust Covers . . . . . 41

    2.5 Experimental Procedure . . . . . 41

    2.6 Results . . . . . 44

    2.7 Discussion . . . . . 45

    2.8 Conclusion . . . . . 45

    2.9 Recommendations . . . . . 46



UNCLASSIFIED

~~SECRET~~  
Security Information

CHAPTER 3	RADIATION EXPOSURE EQUIPMENT . . . . .	47
3.1	Abstract . . . . .	47
3.2	Objective . . . . .	47
3.3	Introduction . . . . .	47
3.4	Description of Equipment . . . . .	48
3.5	Experimental Procedure . . . . .	49
3.6	Results . . . . .	50
3.7	Discussion . . . . .	51
3.8	Conclusions . . . . .	52
CHAPTER 4	INSTRUMENTATION . . . . .	58
4.1	Abstract . . . . .	58
4.2	Introduction . . . . .	58
4.3	Instruments . . . . .	58
4.3.1	Photoelectric Relay . . . . .	58
4.3.2	Air Blast Overpressure Relay . . . . .	61
4.3.3	Ground Shock Relays . . . . .	62
4.3.4	Silicone Oil Timer . . . . .	64
4.3.5	Magnetic Trip . . . . .	66
4.3.6	Time Delay Relay . . . . .	67
4.3.7	Oscillograph Record of Instrument Performance . . . . .	67
4.3.8	Motion Picture Cameras . . . . .	69
4.3.9	Battery Power Supply . . . . .	72
REFERENCES	. . . . .	74

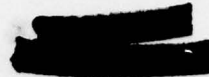

ILLUSTRATIONS

1.1 Blast Barrier With Open Mesh Blast Exposure Cage, Side View . . . . . 13

1.2 Blast Barrier With Open Mesh Blast Exposure Cage, Rear View . . . . . 14

1.3 Cylindrical Blast Exposure Container . . . . . 15

1.4 Mock Dog, Side View . . . . . 16

1.5 Mock Dog Showing Accelerometer In Place . . . . . 16

1.6 Accelerometer Mechanical Drawing . . . . . 17

1.7 Peak Pressure Recorder . . . . . 18

1.8 Shock-mounted Peak Pressure Recorder . . . . . 18

1.9 Mechanical Clock Pressure-Time Recorder . . . . . 19

1.10 Mechanical Clock Pressure-Time Recorder, Mechanical Drawing . . . . . 20

1.11 Electric Motor Pressure-Time Recorder . . . . . 21

1.12 Electric Motor Pressure-Time Recorder, Mechanical Drawing . . . . . 23

1.13 Calibration Curve for Peak Pressure Recorder . . . . . 24

1.14 Orientation of Accelerometer . . . . . 25

1.15 Photomicrograph of Air Pressure Records . . . . . 31

1.16 Photomicrograph of Air Pressure Records . . . . . 31

1.17 Photomicrograph of Air Pressure Records . . . . . 32

1.18 Photomicrograph of Air Pressure Records . . . . . 32

2.1 Cylindrical Thermal Exposure Unit , . . . . . 35

2.2 Cylindrical Thermal Exposure Unit with Shutter Housings Open Showing Animal Container, Ventilation Shutter, Mounting Plate, and Photoelectric Relay . . . . . 36

2.3 Aperture Plate Type I . . . . . 37

2.4 Aperture Plate Type II . . . . . 37

2.5 Graph of Effective Open Times of All the Apertures of a Pair of Aperture Plates . . . . . 38

2.6 Aperture Plate Timer with Bottom Cover Removed . . . . . 39

2.7 Animal Container . . . . . 39

2.8 Cylindrical Thermal Exposure Unit with Shutter Housings Open Showing Animal Container, Heater and Ventilation Fans. . 40

2.9 A-frame Thermal Exposure Units . . . . . 42

2.10 Cylindrical Thermal Exposure Unit with Dust Covers in Place . . . . . 42

2.11 Diagram of Locations of Thermal Exposure Equipment . . . . . 44

2.12 Block Diagram of Electrical Circuits of a Cylindrical Thermal Exposure Unit . . . . . 46

3.1 Single Layer Multicompartment Mouse Cage Positioned in Animal Exposure Container . . . . . 48

3.2 High Level Radiation Exposure Container . . . . . 49

3.3 Pattern of Dosimeters in Mouse Cage , . . . . . 50

4.1 Photoelectric Relay . . . . . 59

4.2 Circuit Diagram of Photoelectric Relay . . . . . 60

UNCLASSIFIED

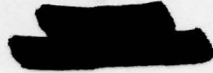

4.3	Air Blast Overpressure Relay . . . . .	61
4.4	Circuit Diagram of Air Blast Overpressure Relay . . . . .	62
4.5	Ground Shock Relay, Ball Type . . . . .	63
4.6	Ground Shock Relay, Ball Type, With Cap and Ball Removed . . . . .	63
4.7	Ground Shock Relay, Arm Type, With Cover Removed . . . . .	64
4.8	Silicone Oil Timer . . . . .	65
4.9	Sectional View of Silicone Oil Timer . . . . .	65
4.10	Magnetic Trip . . . . .	66
4.11	Magnetic Trip Attached to Shutter Bar . . . . .	67
4.12	Circuit Diagram of Time Delay Relay . . . . .	68
4.13	Motion Picture Camera with Cover Open . . . . .	70
4.14	Motion Picture Camera and Battery Box Mounted on Plank . . . . .	71
4.15	Typical Camera Installation . . . . .	71

~~UNCLASSIFIED DATA~~

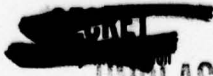

UNCLASSIFIED

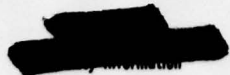

TABLES

1.1 Number of Brake Bars per Swinging Arm Cage  
at Each Station . . . . . 22

1.2 Accelerometer Readings, Shot 8 . . . . . 26

1.3 Peak Pressures, Shot 3 . . . . . 27

1.4 Peak Pressures, Shot 4 . . . . . 28

1.5 Approximate Phase Duration, Shots 3 and 4 . . . . . 29

2.1 Location of the Thermal Exposure Stations . . . . . 43

2.2 Specific Failures or Defects of Thermal Equipment . . . . . 45

3.1 Film and Glass Dosimeter Readings by Station  
and Location, Shot 3 . . . . . 52

3.2 Film and Glass Dosimeter Readings by Station  
and Location, Shot 4 . . . . . 53

3.3 Analysis of Variance, Glass Dosimeter Readings,  
Shots 3 and 4 . . . . . 54

3.4 Analysis of Variance, Glass Dosimeter Readings,  
Shots 3 and 4 . . . . . 55

3.5 Mean Dosimeter Readings, Shots 3 and 4 . . . . . 56

3.6 Vycor Glass Dosimeter Readings in High Level Radiation  
Exposure Containers, Shots 3 and 4 . . . . . 57

4.1 Oscillograph Record of Instrument Performance . . . . . 69

4.2 Camera Placement and Film Condition . . . . . 73



UNCLASSIFIED

CHAPTER 1

AIR BLAST EXPOSURE EQUIPMENT

1.1 ABSTRACT

Two methods of exposing animals to the direct effects of atomic bomb air blast were investigated. In the first, wooden dogs containing accelerometers were exposed in open mesh cages suspended above a protective barrier on swinging arms and slide wires so that animal and cage would accelerate together thus preventing indirect blast injuries. Difficulty was experienced in obtaining reliable "braking" action for deceleration of the cages without the development of excessive forces, while the situation was further complicated by the difference between predicted and experimental peak pressure values. The wooden dogs were also subjected to thermal radiation and flying missiles before reaching a safe position behind the protective barrier.

In the second method peak pressure and pressure-time recorders were exposed in Operation GREENHOUSE animal exposure containers with open ends. This afforded protection against thermal radiation and flying missiles but allowed free access to the pressure wave. The peak pressure and pressure-time records obtained, agree favorably with pressure data collected by other groups. Results of using this method indicate its usefulness for the exposure of animals to atomic bomb air blast overpressure.

1.2 OBJECTIVE

The objective of this phase of the project was to design, construct and evaluate instruments and equipment for the exposure of animals within the lethal to sublethal range to the direct effects of atomic bomb air blast with the minimum of injury from indirect effects.

1.3 INTRODUCTION

Atomic bomb air blast injuries in animals or man may be divided into direct and indirect effects. Direct effects are due to the shock front and the following period of over and under-pressure, while indirect effects result from the acceleration of the individual or his environment. This classification is useful from a practical standpoint since personnel in the open are subjected to both, while individuals in trenches, tanks, gun emplacements and buildings under certain conditions, would be subjected to direct effects, mostly overpressure.

UNCLASSIFIED

UNCLASSIFIED

~~SECRET~~

The investigation of direct atomic bomb air blast injuries in animals is largely dependent upon the design of exposure equipment to eliminate or minimize indirect air blast, thermal, and ionizing radiation effects. In this study two methods were investigated, one designed to expose animals to the full effects of the shock front and overpressure, the other to minimize the shock front while exposing animals to the effects of overpressure. In the first method, wooden dogs containing accelerometers were mounted above a protective barrier in open mesh cages on swinging arms and slide wires designed to have dog and cage accelerate together toward a sheltered position some distance behind this barrier. This method is an extension of the use of open mesh cages on slide wires used during Operation CROSSROADS 1/ in an attempt to evaluate the direct air blast effects of the Test Able atomic bomb detonation upon rats.

In the second method, Operation GREENHOUSE animal exposure containers 2/, modified by removal of the ventilation shutters, were evaluated as blast exposure containers by means of peak pressure and pressure-time recorders. These containers permitted the free entrance of air overpressure affording adequate protection against flying missiles and thermal radiation.

Peak pressure measurements were made by means of a pressure recorder designed and constructed by the Cornell Aeronautical Laboratory, Inc., 3/ for air pressure measurements within Operation GREENHOUSE animal exposure containers. Pressure-time measurements were made by the addition of a time base to this recorder.

#### 1.4 DESCRIPTION OF EQUIPMENT

##### 1.4.1 Blast barrier

Blast barriers, Figs. 1.1 and 1.2, were used in Shots 5 and 8 as a support and shelter for open mesh blast exposure cages. The width of the barrier was 12 feet, the height 6 feet, and the overall length 10 feet. The frame of the barrier was constructed of 8 x 8 fir timbers firmly bolted together. The front face and bottom were covered by 2 inch planks. The barriers were placed with their 6 x 12 foot front faces perpendicular to a line from ground zero and earth was bulldozed in front of the barrier to form a 30 degree slope. A total of six barriers were constructed.

##### 1.4.2 Open Mesh Blast Exposure Cages

Open mesh blast exposure cages, Figs. 1.1 and 1.2, were constructed of  $1/8$  x 1 x 1 inch steel wire mesh having a diameter of

~~SECRET~~

~~SECRET~~

UNCLASSIFIED

SECRET



Fig. 1.1 Blast Barrier with Open Mesh Blast Exposure Cage, Side View

18 inches and length of 22 inches. The ends were reinforced by 1 x 2 inch steel channel welded to the wire mesh, one end having an 11 x 14 inch door.

Four cages were mounted above each blast barrier. Two of the cages were supported by 3/8 inch steel cables about 40 feet long by means of steel rings welded to the end channels of the cages. The cables were supported about 30 inches above the top of the barrier by stanchions and were secured at each end by dead men buried in the ground in front of and behind the barrier. The purpose of these cables was to allow the cage when accelerated by air blast to slide down the cables to a sheltered position behind the barrier. Deceleration of the cage was accomplished by spreading the cables at their lower ends. For Shot 5 the length of the cables was about 40 feet which proved to be inadequate and was increased to about 50 feet for Shot 8.

The other two cages were supported above the barrier by pairs of steel arms pivoted at a position below the top of the barrier. This permitted the cages to move in an arc to a protected position behind the barrier after receiving the impulse of the shock wave. The 6 foot steel arms were welded to the end channels of the cage at their upper ends and to a 1 1/2 inch steel shaft at the lower end. The steel shaft was supported by two pillow blocks, bolted to the barrier frame 4 feet below the top of the barrier.

SECRET

SECRET

UNCLASSIFIED

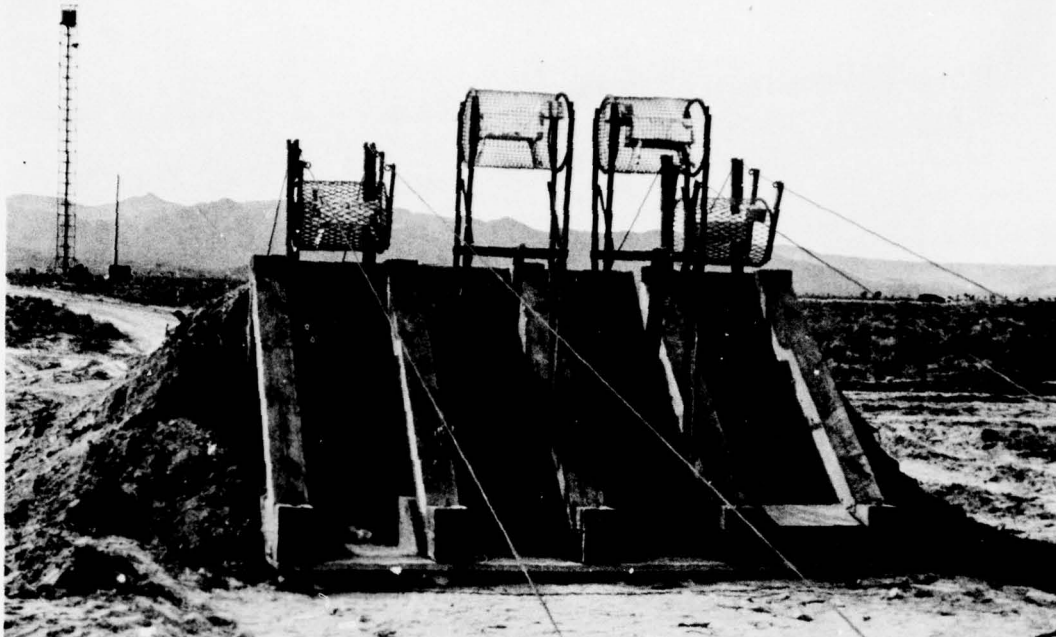

Fig. 1.2 Blast Barrier with Open Mesh Blast Exposure Cage, Rear View

Cold rolled steel bars attached to a cross member of the frame of the swinging arm cage passed in front of the pivot shaft to a slot in the base of the barrier. Deceleration to prevent the cages from striking the ground was accomplished by the bending of these steel bars.

#### 1.4.3 Cylindrical Blast Exposure Containers

Operation GREENHOUSE animal exposure containers were used in Shots 3 and 4 for blast pressure studies. These consisted of aluminum cylinders 26 inches in diameter and 48 inches long with end flanges to which shutter housings were attached. The shutter plates were omitted in order to allow the free access of air pressure. They were bolted to heavy timber skids and sandbagged in place.

The skids were rectangular in shape, constructed of two 8 x 12 inch timbers 10 feet long and two 4 x 12 inch timbers 5½ feet long securely bolted at the corners. The end flanges of the containers were bolted to ½ inch steel mounting plates which were in turn bolted to the 8 x 12 inch sides of the timber skids. Five of these units were constructed, Fig. 1.3.

#### 1.4.4 Wooden Dog

Mock dogs, Figs. 1.4 and 1.5, were constructed of wood,

UNCLASSIFIED

UNCLASSIFIED



Fig. 1.3 Cylindrical Blast Exposure Container

having a width of 6 inches, and length 19 inches. The body was provided with a hinged cover and divided into three compartments. Accelerometers were placed in the central compartment, and sufficient lead shot in the end compartments to increase the total weight to 30 pounds. The outside surface of the mock dog was covered with aluminum foil to minimize thermal damage. Twenty-four of these dogs were provided.

#### 1.4.5 Accelerometers

Accelerometers for use in the wooden dogs were designed and constructed in accordance with suggestions received from the Engineering Mechanics Division, Bureau of Standards.

As shown in Fig. 1.6, this device consists essentially of a support bar measuring  $\frac{1}{2} \times \frac{3}{4} \times 4\frac{1}{2}$  inches to one end of which was attached a 75 ST aluminum spring,  $\frac{1}{32}$  inch thick,  $\frac{1}{2}$  inch wide and approximately 3 inches long supporting a 47 gram weight on its free end. A phosphor bronze needle was attached to the free end in such a manner as to scribe a line on a smoked recording plate when subjected to acceleration. The undamped frequency of this system was 14 cycles per second. Damping was provided between the sides of the weight and two parallel plates attached to the support bar by a film consisting of a mixture of four parts of 12,500 and one part of 60,000 centistokes silicone oil. The damping remained constant for six days.

UNCLASSIFIED

UNCLASSIFIED

~~SECRET~~

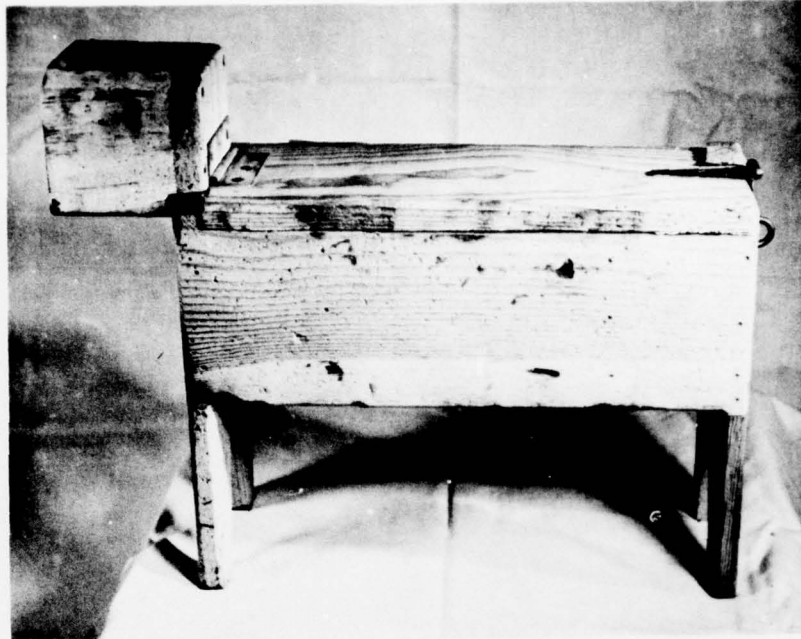

Fig. 1.4 Mock Dog, Side View



Fig. 1.5 Mock Dog showing Accelerometers in place

ATOMIC ~~SECRET~~

~~SECRET~~  
information  
UNCLASSIFIED

UNCLASSIFIED

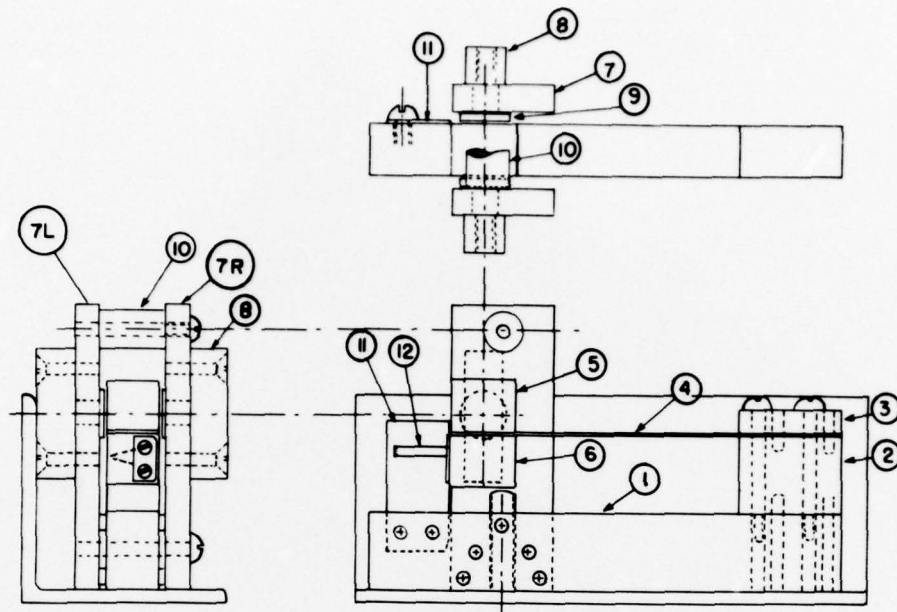

Fig. 1.6 Accelerometer Mechanical Drawing. 1. base; 2 & 3. spring support; 4. 75 ST aluminum spring; 5 & 6. weight; 7R & 7L right and left damper support plates; 8. damper plate adjustments; 9. damper plate; 10. tie bar; 11. recording plate; 12. phosphor bronze scribe.

#### 1.4.6 Peak Pressure Recorder

The peak pressure recorder consisted of a pressure-sensitive metal bellows 1 5/8 inches in diameter supporting a phonograph needle bearing against a smoked stainless steel plate 5/8 x 1 1/4 inches, Fig. 1.7. Pressure variations caused vertical deflections of the needle. The frequency of the bellows and needle support was 145 cycles per second. Since 23.1 psi produced 1 mm of travel, microscopic examination of the record was required. At the time the recording plate was inserted, a reference line was scribed by moving the plate at right angles to the needle travel. The system was contained in a perforated metal housing measuring 2 x 2 x 2 3/4 inches. This was rubber band shock-mounted from the corners of a 7 inch cubical frame, Fig. 1.8. This pressure recorder was designed and constructed by the Cornell Aeronautical Laboratory 3/ for use in connection with Operation GREENHOUSE animal exposure containers.

UNCLASSIFIED

UNCLASSIFIED

~~SECRET~~

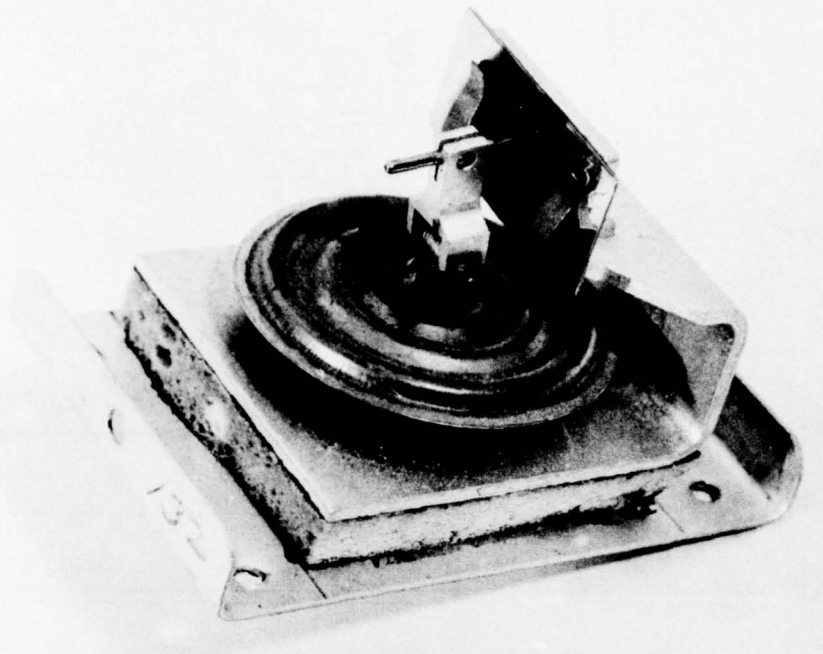

Fig. 1.7 Peak Pressure Recorder

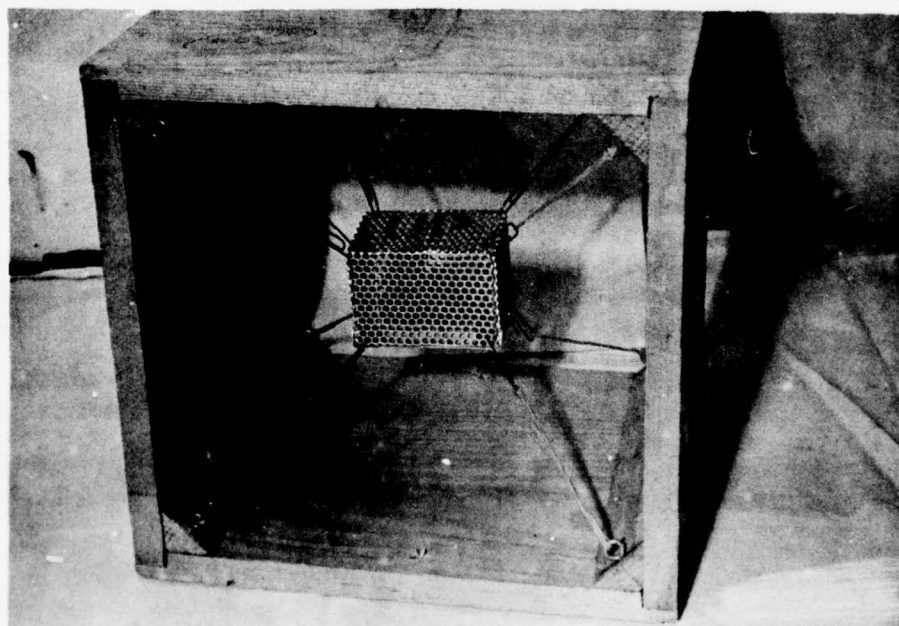

Fig. 1.8 Shock-mounted Peak Pressure Recorder

~~SECRET~~  
ATOMIC ENERGY ACT 1946

~~SECRET~~

UNCLASSIFIED

UNCLASSIFIED

#### 1.4.7 Pressure-time Recorders

Two types of pressure-time recorders were constructed for use in the evaluation of blast pressure exposure containers.

One pressure-time recorder was constructed using the identical bellows and needle assembly described in 1.4.6, the latter in contact with a smoked stainless steel recording disc 1 3/4 inches in diameter mounted on the shaft of the timing mechanism, used in the Mark 57 Mod. 2 time fuse, Figs. 1.9 and 1.10. A 24-volt relay solenoid was adapted to release the clock escapement allowing the record disc to rotate a half revolution in 27 seconds. A stationary needle was used to provide a reference line. The unit was mounted on a 3/16 x 3 x 5 1/2 inch brass plate supported at four corners by eight coil springs in the center of a wooden frame. These recorders were started by the minus 5 second timing signal or photoelectric relays.

The second type of pressure-time recorder was constructed by using the same metal bellows and needle mount previously described, the latter in contact with the outer curved surface of a smoked stainless steel drum 1 1/2 inches in diameter driven by an 18-volt 3 rpm Haydon

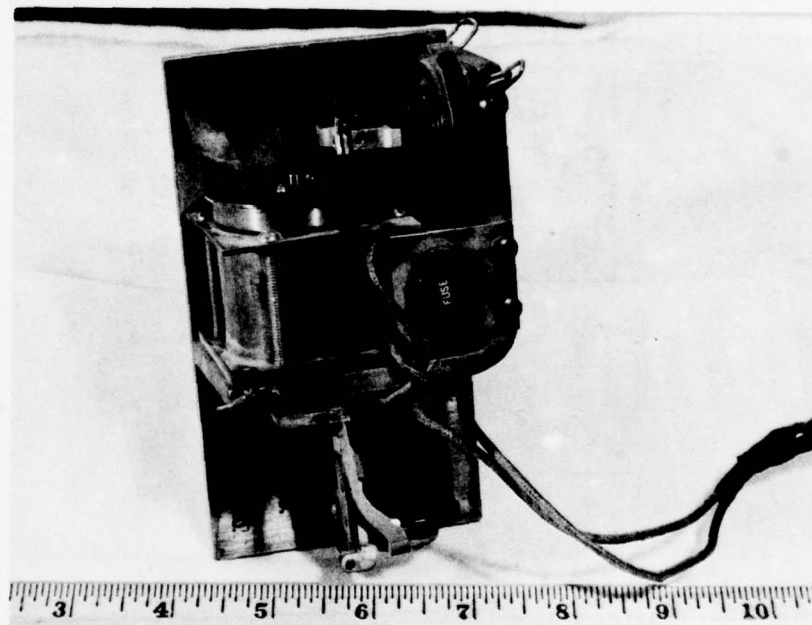

Fig. 1.9 Mechanical Clock Pressure-time Recorder

UNCLASSIFIED

UNCLASSIFIED

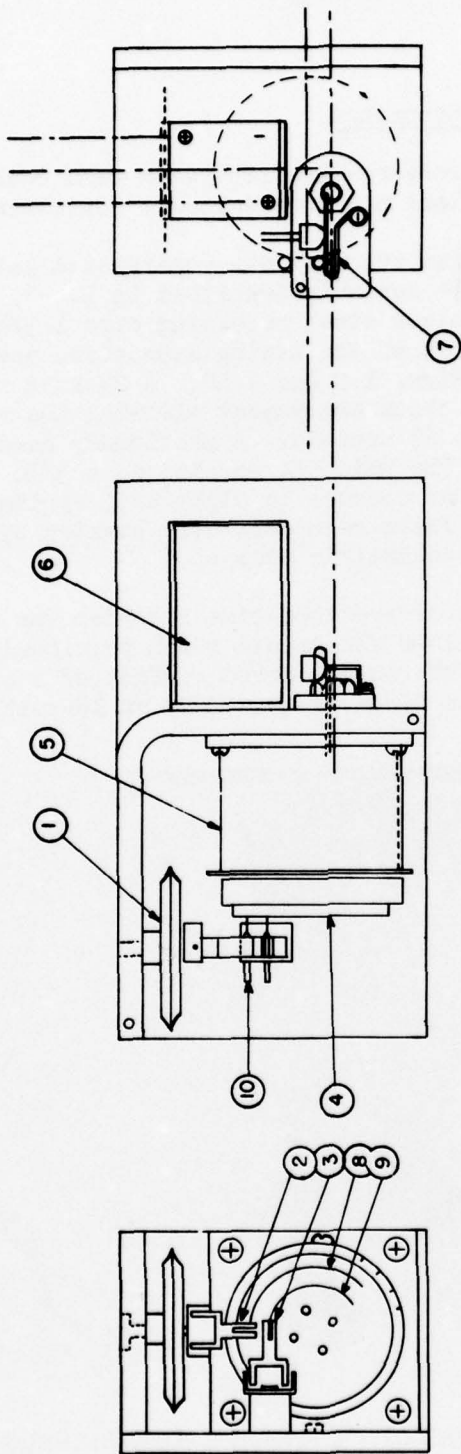

Fig. 1.10 Mechanical Clock Pressure-time Recorder, Mechanical Drawing. 1. metal bellows; 2. needle support; 3. needle support for base line; 4. recording disc; 5. clock mechanism; 6. solenoid; 7. starting mechanism; 8. pressure trace; 9. base line trace; 10. needle.

UNCLASSIFIED

timer motor, Fig. 1.11. A mechanical drawing of this recorder is shown in Fig. 1.12. A stationary needle was used to scribe a reference line. A microswitch cut-off limited the rotation of the recording drum to one revolution. The unit was mounted on a brass plate measuring  $1/4 \times 3 \times 3\frac{1}{2}$  inches and was shock-mounted as described above. These recorders were started by ground shock relays. Transcription of both types of pressure-time records was accomplished by means of a low power microscope with a calibrated mechanical stage.

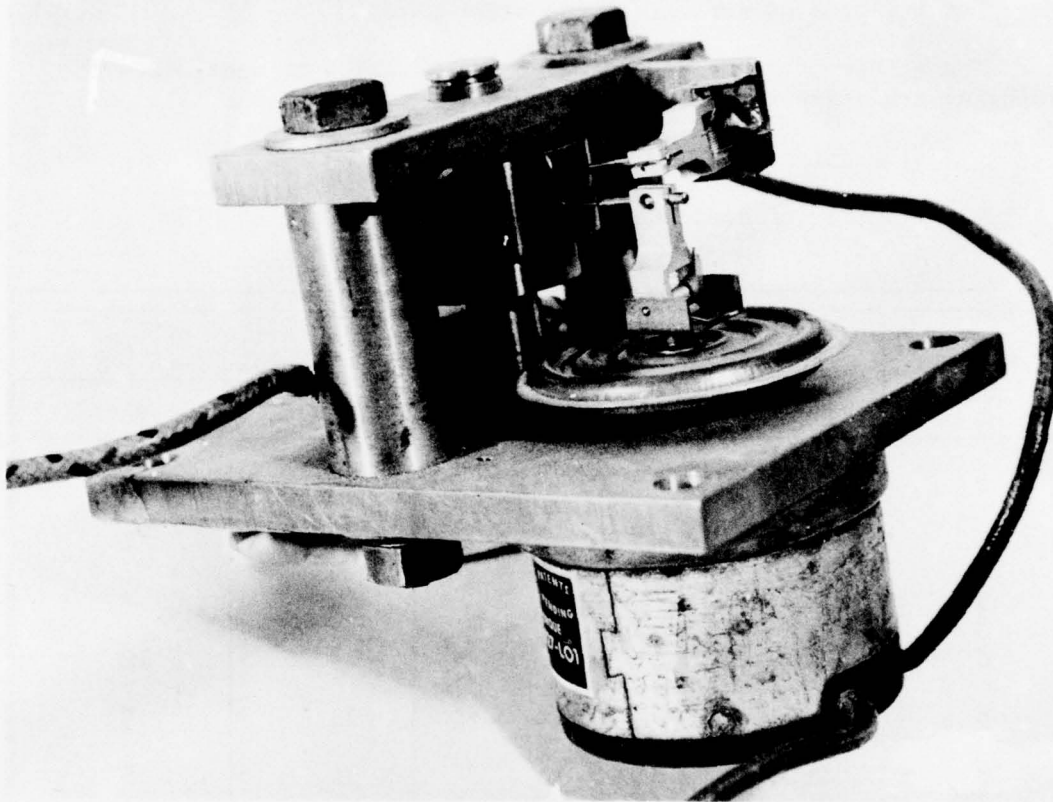

Fig. 1.11 Electric Motor Pressure-time Recorder

1.5 EXPERIMENTAL PROCEDURE

In Shot 5 wooden barriers were placed at 1100, 1400 and 2100 feet and in Shot 8 at 1800, 2100 and 2600 feet, the expected ground ranges for 30, 20 and 10 psi. Wooden dogs containing accelerometers were placed in the open mesh cages several days before the test.

Two movie cameras described in Chapter 4 were placed at one side of each wooden barrier in order to record the movement of the open mesh cages at the time of arrival of the blast wave.

The number of brake bars used at each station to decelerate the swinging arm cages varied with distance as given in Table 1.1.

TABLE 1.1

Number of Brake Bars per Swinging Arm Cage at Each Station

Shot No.	Distance (feet)	Expected psi	Number of Brake Bars	
			Cage 1	Cage 2
5	1100	30	6	4
5	1400	20	4	5
5	2100	10	2	3
8	1800	30	14	12
8	2100	20	11	9
8	2600	10	10	8

In Shot 3, five cylindrical exposure containers were placed at 845, 1114, 1394, 1682 and 1974 feet ground range. In Shot 4 the corresponding distances were 1126, 1625, 1913, 2796 and 4283 feet. These distances were chosen in an attempt to cover the range of 30 to 10 psi for each test.



UNCLASSIFIED

One or more peak pressure and three pressure-time recorders were placed in each container. The pressure-time recorders were connected electrically to battery boxes and timing signals. Several types of timing signals were used such as the minus 5 second signal, photo-electric relay and ground shock relay.

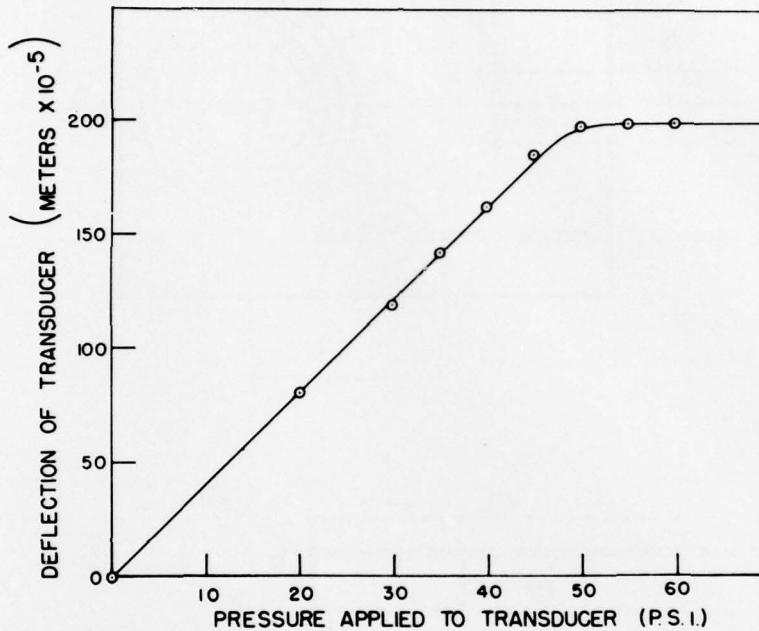

Fig. 1.13 Calibration Curve for Peak Pressure Recorder

Evaluation of the pressure-time records was based on the Cornell Laboratory calibration curve, Fig. 1.13. This curve was made for slow rise times with no allowance for overshoot. An attempt was made to determine the relation between rapid rise time and overshoot in the large shock tube at the Ballistics Research Laboratory, Aberdeen Proving Ground. This was unsuccessful due to superimposed reflections.

#### 1.6 RESULTS

The open mesh exposure cages tested in Shots 5 and 8 were not satisfactory in many respects. On the other hand the cylindrical exposure containers in Shots 3 and 4 proved to be very satisfactory.

In Shot 8 the expected pressure limits were not reached. The deceleration of the open mesh cages was satisfactory at the 30 and 20 psi stations but was excessive for the two swinging arm cages at the

UNCLASSIFIED

10 psi station so that these cages did not move behind the barrier. None of the wooden dogs was damaged. Accelerometer readings obtained are given in Table 1.2.

The accelerometers in the wooden dogs were oriented to measure starting, stopping and radial acceleration, Fig. 1.14. Not all measurements were made in each cage. Full scale deflection occurred at 6 g. The brake bars of cages B and C at 2600 feet did not bend appreciably and the records were undoubtedly caused by vibration of the swinging arms and movement of the dog inside the cage.

In Shot 3 all pressure recorders were recovered undamaged from the five cylindrical exposure containers. The pressure data obtained are given in Table 1.3. In Shot 4 the first station was completely destroyed. The pressure recorders were recovered undamaged from the other four stations. The pressure data obtained are given in Table 1.4. Approximate phase relations for Shots 3 and 4 are given in Table 1.5. Selected photomicrographs of air pressure changes are given in Figs. 1.15 through 1.18.

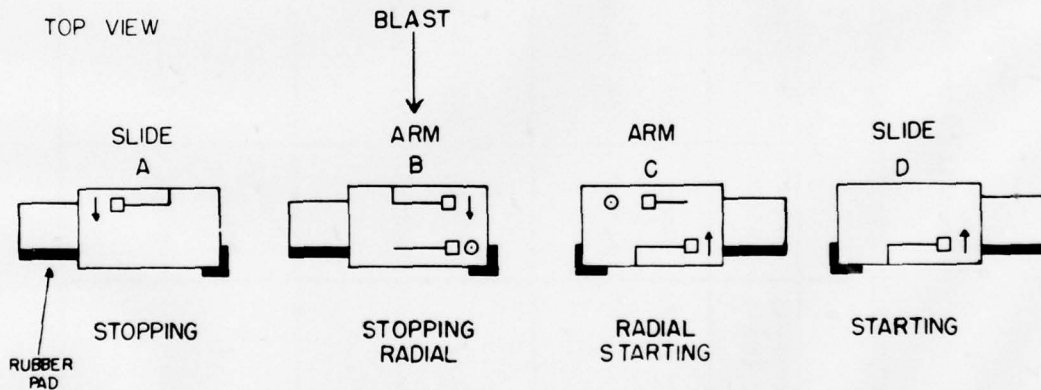

Fig. 1.14 Orientation of Accelerometers

UNCLASSIFIED



TABLE 1.2  
Accelerometer Readings, Shot 8

Ground Range (ft.)	Cage A		Cage B		Cage C		Cage D	
	Direction	Reading (g)	Direction	Reading (g)	Direction	Reading (g)	Direction	Reading (g)
1800	Stop	Off Scale	Stop	Off Scale	Start	Off Scale	Start	Off Scale
	--	--	Radial	Off Scale	Radial	Off Scale	--	--
2100	Stop	1.8	Stop	Off Scale	Start	Off Scale	Start	Off Scale
	--	--	Radial	Off Scale	Radial	Off Scale	--	--
2600	Stop	1.3	Stop	5.4	Start	Off Scale	Stop	Off Scale
	--	--	Radial	5.2	Radial	Off Scale	--	--

SECRET

SECRET

UNCLASSIFIED

UNCLASSIFIED

TABLE 1.3

Peak Pressures, Uncorrected To Sea Level, Shot 3

Ground Range (ft.)	Recorder	Positive Peak psi		Negative Peak psi	
		Reading	Average	Reading	Average
845	PPR 212	10.6		2.6	
845	EMR 3	11.0		1.3	
845			10.8		1.9
1114	PPR 122	9.3		1.7	
1114	MCR 12	10.4		1.6	
1114	EMR 1	11.4		1.7	
1114	EMR 4	13.1*		1.7	
1114			10.3		1.7
1394	PPR 22	9.8		2.6	
1394	MCR 6	9.8		1.7	
1394	EMR 5	10.7		1.7	
1394			10.0		2.0
1682	PPR 166	9.3		1.3	
1682	MCR 10	8.5		2.1	
1682	MCR 4	9.3		1.7	
1682	EMR 7	10.0		1.9	
1682	EMR 8	8.9		1.7	
1682			9.2		1.7
1974	EMR 9	8.1		0.7	
1974	EMR 10	8.5		1.7	
1974			8.3		1.3

PPR, Peak Pressure Recorder; MCR, Mechanical Clock Recorder; EMR, Electric Motor Recorder.

\*Note: This record appears to be grossly out of line for reasons unknown, not used in averages.

UNCLASSIFIED

TABLE 1.4

Peak Pressures, Uncorrected To Sea Level, Shot 4

Ground Range (ft.)	Recorder	Positive Peak psi		Negative Peak psi	
		Reading	Average	Reading	Average
1625	PPR 204	8.5		2.6	
1625	MCR 12	7.7		3.8	
1625	MCR 10	7.7		4.2	
1625	MCR 4	7.7		4.2	
1625			7.9		3.7
1913	PPR 22	7.7		1.7	
1913	MCR 9	6.9		3.8	
1913	MCR 1	6.8		1.7	
1913	MCR 5	6.8		2.9	
1913			7.0		2.6
2796	PPR 212	6.8		1.7	
2796	MCR 2	7.7		2.9	
2796	EMR 3	6.8		2.1	
2796			7.1		2.6
4283	PPR 166	5.5		No neg trace	
4283	MCR 6	5.5		0.82	
4283	EMR 1	5.5		1.7	
4283	EMR 7	5.9		0.82	
4283			5.6		1.1

PPR, Peak Pressure Recorder  
MCR, Mechanical Clock Recorder  
EMR, Electric Motor Recorder

1.7 DISCUSSION

A number of difficulties were encountered in the use of the open mesh blast exposure cages. Deceleration of the cages was critical and directly related to bomb yield and distance. In Shot 5 insufficient brake bars and cable spreading resulted in violent deceleration of the cages and smashing of most of the wooden dogs. In Shot 8 the swinging arm cages at the most distant station had too many brake bars and there-

TABLE 1.5

Approximate Phase Duration, Shots 3 and 4

Shot No.	Ground Range (ft.)	Positive Phase (sec.)	Negative Phase (sec.)
3	1114	0.7	3.7
3	1394	0.7	2.7
3	1682	0.7	(could not determine)
4	1625	0.6	1.3
4	1913	0.7	1.6
4	4283	1.2	1.6

fore did not move to a sheltered position behind the barrier.

Indirect blast injury due to flying missiles was also a serious hazard. It was hoped that the open mesh cages would proceed to a sheltered position behind the barriers before encountering many missiles. This was probably the case although a considerable number of small missiles were encountered as indicated by numerous indentations upon the surface of the wooden dogs.

Protection against thermal radiation was not attempted in this study. As shown by flashburn studies conducted at Operation GREENHOUSE, the thermal energy effective in producing burns was delivered in the first half second. A thermal shield would therefore be required if further use of this type of blast exposure equipment were attempted.

The low temperatures encountered at the Nevada Proving Grounds necessitated the provision of heat for animals. This was readily accomplished in the case of the cylindrical exposure containers as

UNCLASSIFIED

described in Chapter 2 but could not readily be provided in the case of open mesh cages.

The cylindrical exposure containers afforded protection against flying missiles and thermal radiation. Since animals were not used in these containers, shutters and heating equipment as described in Chapter 2 were not necessary.

The use of timber skids as portable mounting for the containers greatly increased their usefulness in contrast to the concrete slabs employed at Operation GREENHOUSE.

The peak pressure and pressure-time recorders were comparatively crude instruments which should now be improved in design and construction. For example, the open construction permitted the entrance of dust resulting in the partial obscuring of the pressure record.

Protection against ionizing radiation has not been considered since its effects are delayed while blast effects are immediately apparent. If desired, gamma ray and neutron shielding could be provided for the cylindrical exposure containers.

Since the degree and type of injury resulting from air blast depend markedly upon many factors such as peak pressure, rate of rise and duration, the measurement of the parameters of the blast wave to which animals are exposed appears to be of the utmost importance in the interpretation of the biological effects. Simple compact pressure-time recorders may be just as important in air blast studies as are dosimeters in ionizing radiation studies.

Up to the present, attention has been focused largely on the lethal effects of air blast. It is proposed that sublethal effects may be of considerable importance under combat conditions. Minor injuries such as ruptured ear drums, slight lung hemorrhage, or cerebral damage may temporarily incapacitate personnel rendering them ineffective.

#### 1.8 CONCLUSION

Open mesh exposure cages mounted either on swinging arms or slide wires appear to present many difficulties which make their usefulness for direct air blast studies questionable. The cylindrical exposure containers on the other hand appear to provide a relatively simple and effective means of studying the direct effects of air blast in partially protected locations.

UNCLASSIFIED  
ATOMS

UNCLASSIFIED

UNCLASSIFIED

[REDACTED]



Fig. 1.15 Photomicrograph of Air Pressure Changes Mechanical Clock Recorder No. 12, 1114 Feet Ground Range, Shot 3, about 21x

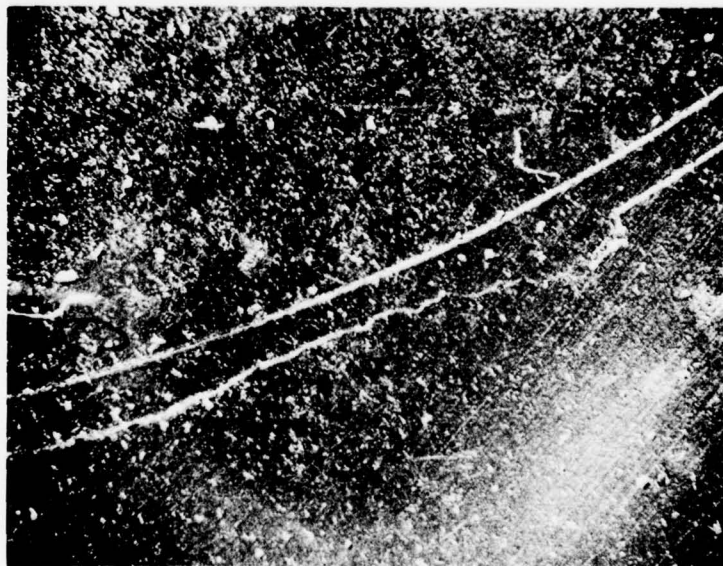

Fig. 1.16 Photomicrograph of Air Pressure Changes Mechanical Clock Recorder No. 1, 1913 Feet Ground Range, Shot 4, about 21x.

[REDACTED]

[REDACTED]

UNCLASSIFIED

UNCLASSIFIED

[REDACTED]

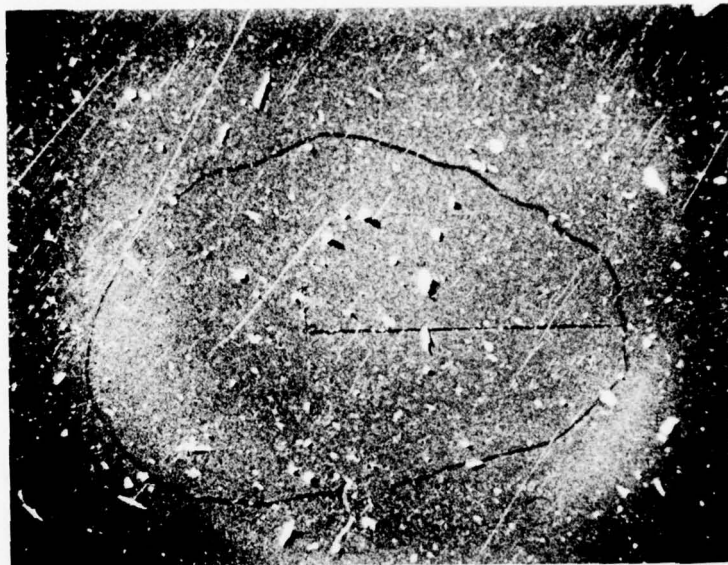

Fig. 1.17 Photomicrograph of Air Pressure Changes Peak Pressure Recorder No. 212, 2796 Feet Ground Range, Shot 4, about 21x

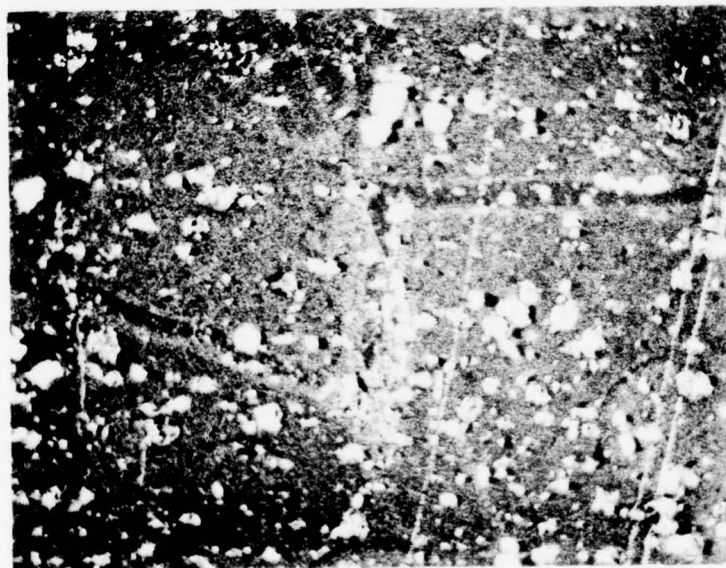

Fig. 1.18 Photomicrograph of Air Pressure Changes Mechanical Clock Recorder No. 10, 1682 Feet Ground Range, Shot 3, about 108x

[REDACTED] DATA  
ATOMIC ENERGY ACT 1946

[REDACTED]

UNCLASSIFIED

UNCLASSIFIED

CHAPTER 2

THERMAL EXPOSURE EQUIPMENT

2.1 ABSTRACT

Cylindrical exposure containers developed for Operation GREENHOUSE in connection with the study of total body irradiation of animals were modified to permit thermal radiation burns in swine. The animals were exposed behind multiple shutter-controlled apertures to provide an intensity vs time biological evaluation of the thermal energy. The equipment performed in a satisfactory manner. The series of burns obtained by the use of this equipment was studied under Project 4.6 conducted by the University of Rochester.

2.2 OBJECTIVE

The objectives of this part of the project were: (1) To modify Operation GREENHOUSE animal exposure containers for use in thermal burn field studies in swine and to test this equipment under actual field conditions; (2) To adapt this equipment for biological evaluation of the thermal intensity vs time relations during the first half second of exposure; (3) To develop equipment with which to compare large and small area burns on the same animal in order to determine the validity of the standard size (1.7 cm. diameter) carbon arc burn studied by the Thermal Burn Section, Atomic Energy Project, University of Rochester.

2.3 INTRODUCTION

During Operation GREENHOUSE the Naval Medical Research Institute and the University of Rochester cooperated in a thermal burn study. Eighty-two animals, swine and dogs, were exposed to thermal radiation in large concrete and wooden blockhouses. Ports covered by aperture plates provided both fast and slow time breakdown, plus broad-band wavelength subdivision of the thermal energy. It was shown that no burning occurred in the ultra-violet region or during the first maximum of the bomb's thermal flux, but did occur during the first half second. However the slow aperture plate which covered a period of 2 seconds was inadequate for detailed analysis of this short time interval.

Operation TUMBLER-SNAPPER provided the opportunity to extend these time-intensity studies and also make a comparison between large and small area burns since only single small area burns (1.7 cm. diameter) were used in control studies at the University of Rochester.

UNCLASSIFIED

UNCLASSIFIED

The cylindrical animal exposure container used during Operation GREENHOUSE for ionizing radiation studies proved to be very practical from the standpoint of blast resistance, internal environment, accessibility, and size  $2\frac{1}{2}$ . For this reason, it was decided to modify a sufficient number of containers into thermal exposure units. Accordingly, 12 cylinders and 12 liner-cages were modified by cutting a rectangular opening through one side in order to admit thermal radiation. Aperture plates containing 10 windows each, some of which were affected by magnetic shutters, were bolted over these rectangular openings. The cylinders were bolted together in pairs and fastened to timber skids and sand-bagged in position. The aperture plate shutters were actuated electrically by a timer, which was, in turn, initiated by a photoelectric relay described in Chapter 4. Each cylinder unit was fitted with heaters and ventilation shutters and fans.

The design and procurement of the animal exposure equipment was the responsibility of the Naval Medical Research Institute and is the subject of this chapter. The burn studies were conducted by the University of Rochester, and the results given in the report of Project 4.6 Operation SNAPPER.

#### 2.4 DESCRIPTION OF EQUIPMENT

##### 2.4.1 Modification of Operation GREENHOUSE Exposure Containers

Twelve Operation GREENHOUSE animal exposure containers with their liner-cages were returned from the Pacific Proving Grounds for modification into thermal exposure units, Fig. 2.1. This equipment consisted of a  $\frac{3}{16}$  inch thick pressure cylinder 26 inches in diameter and 48 inches long with welded end flanges for mounting. The liner-cages were double walled insulated cylinders which fitted into the pressure cylinders.

Through the wall of each cylinder and liner-cage a rectangular opening of 10 x 15 inches was cut. The long axis of the opening was parallel to that of the cylinder and was midway between its end flanges. The original spacers were removed from each liner-cage and four solid aluminum spacers substituted in order to increase its strength. This was necessary because the blast load of the aperture plate was borne entirely by the liner-cage. A heavy, welded steel frame with flanges to which the aperture plate could be bolted, was fitted in the opening in the liner-cage. Brackets were welded to the frame to support the animal exposure cage.

The 12 cylinders were bolted together into six pairs and each pair was attached to a heavy timber skid, Paragraph 1.4.3, by

UNCLASSIFIED

UNCLASSIFIED

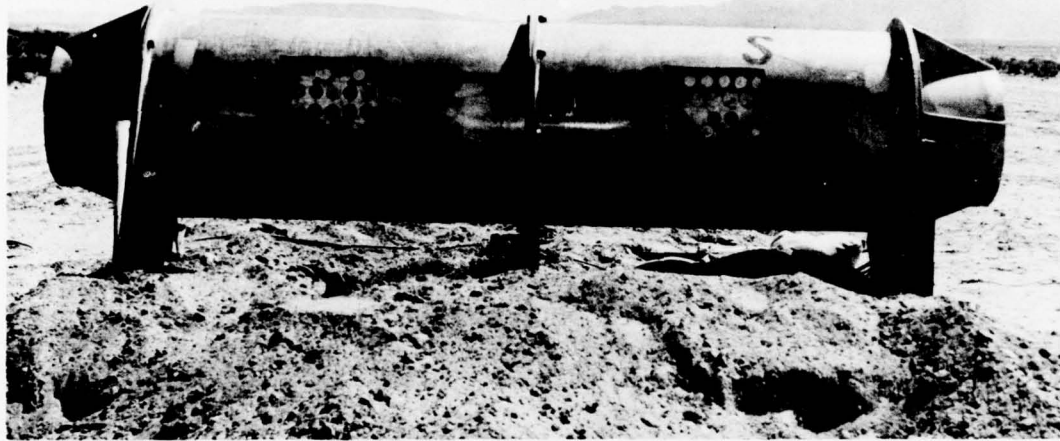

Fig. 2.1 Cylindrical Thermal Exposure Unit

means of steel mounting plates, Fig. 2.2. A series of mounting holes in these plates, plus a 12 degree freedom of rotational position of the liner-cage within the pressure cylinders, allowed the aperture plate to be adjusted to view a bomb elevated from 0 to 48 degrees above ground level.

#### 2.4.2 Aperture Plates

Aperture plates were designed to cover the rectangular opening in the side of each liner-cage, to subdivide the thermal energy temporally in order to produce distinct areas of burn on swine skin, each corresponding to a definite time interval. The plates were made of aluminum alloy 0.75 inches thick and 10 inches by 15 inches in size. Each contained 10 openings fitted with 1.50 inch diameter fused quartz windows, and several rotary solenoids which actuated shutters affecting most of the windows. The windows were necessary to prevent damage to the pigs from air blast and flying missiles. Fused quartz is the material of choice in this application because of its high transmission in bomb thermal wavelengths, high strength, and high thermal shock resistance.

The aperture plates were of two types as shown in Figs. 2.3 and 2.4. It can be seen that the shutters, in most cases, cover alternate windows, thus enabling maximum utilization of solenoids and space.

UNCLASSIFIED

UNCLASSIFIED

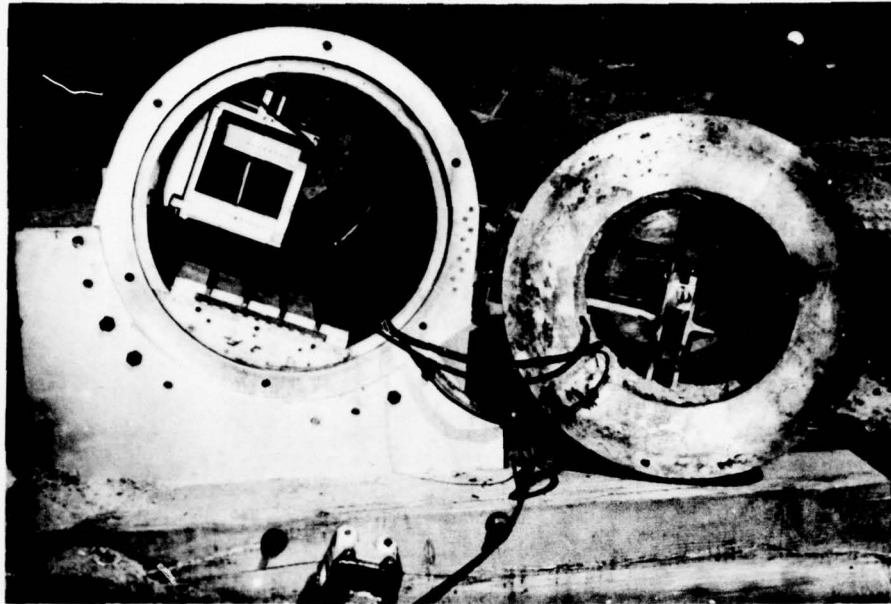

Fig. 2.2 Cylindrical Thermal Exposure Unit with Shutter Housings Open Showing Animal Container, Ventilation Shutter, Mounting Plate, and Photoelectric Relay

The time intervals provided by a pair of aperture plates yield a three-way breakdown of the first half second. Figure 2.5 represents in bargraph form the effective open times of all the apertures of a pair of aperture plates as used on each thermal exposure unit.

#### 2.4.3 Aperture Plate Timer

In order to provide the proper electrical signals to actuate the aperture plate solenoids a special timer was designed and constructed since no suitable commercial timer was available. This timer when initiated by an external signal provided separate electrical signals at 100, 200, 300, 400, 500 and 600 msec. plus or minus 5 per cent. It required no standby power and after maintaining the signals for 10 seconds disconnected all circuits and returned to a condition of no standby power. The timer was housed in a case measuring 3 x 10 x 12 inches, Fig. 2.6.

The timing function was performed by a gear-reduction, governor controlled, 120 RPM motor connected to a five point cam in contact with a roller actuated SPDT microswitch. This provided two square wave signals 180 degrees out of phase with a period of 100 msec. One signal was used to advance a stepping relay, and the other to apply power through the arm of the stepping relay to the rotary solenoids on the aperture

UNCLASSIFIED

UNCLASSIFIED

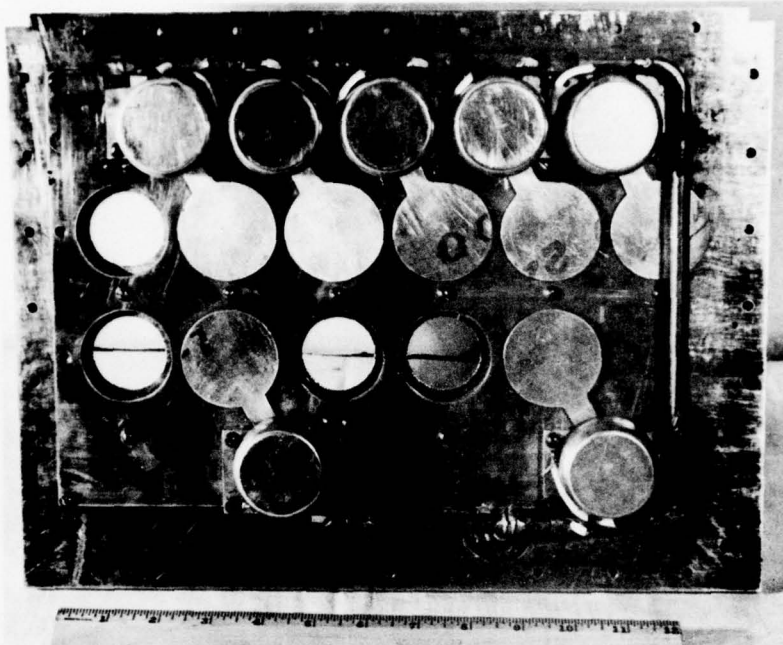

Fig. 2.3 Aperture Plate Type I

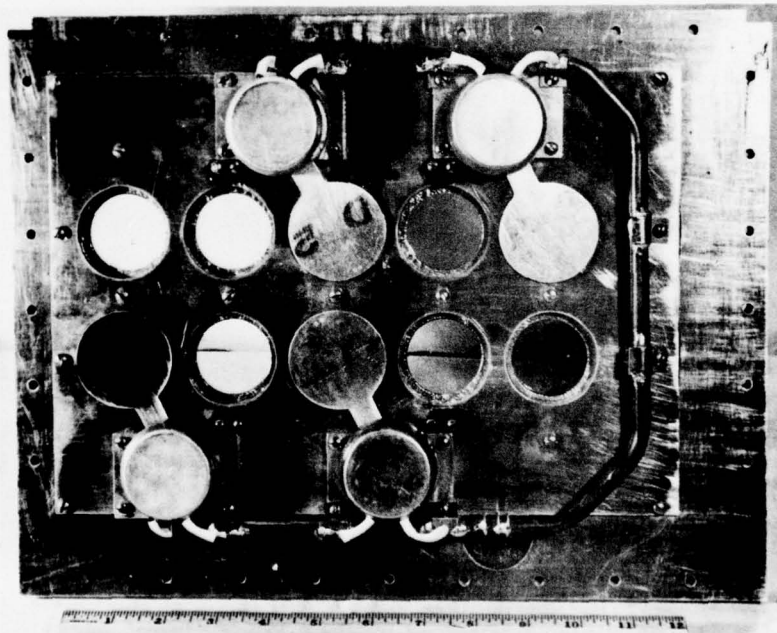

Fig. 2.4 Aperture Plate Type II

UNCLASSIFIED

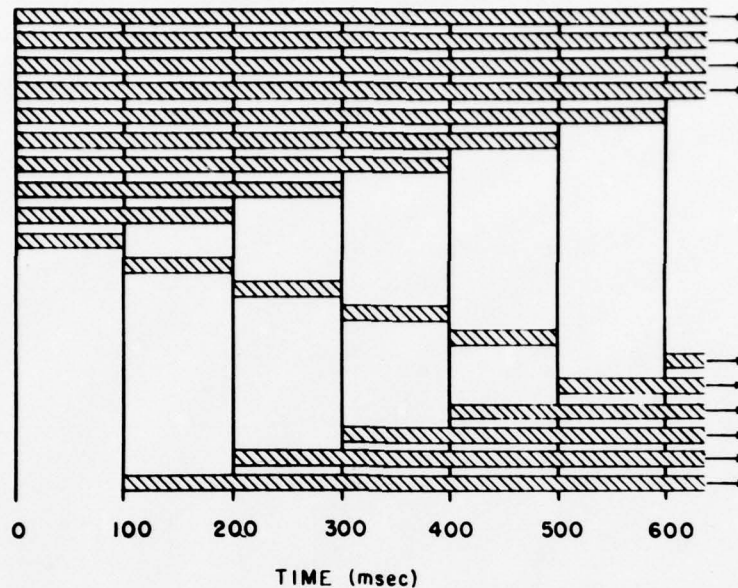

Fig. 2.5 Graph of Effective Open Times of All the Apertures of a Pair of Aperture Plates. Shaded area represents open time.

plates. In each circuit there was a relay connected in a holding circuit in order that the solenoid not be inactivated when the arm of the stepping relay moved to the next position. A thermal time delay relay disconnected all circuits 10 seconds following the initial signal. The stepping and holding relays took no part in determining the accuracy of the time signals, this being a function of the cam and motor only.

#### 2.4.4 Animal Container

The animal containers were rectangular boxes 9 inches wide, 9 inches high, and 40 inches long, which fitted into the brackets in the liner-cages, Fig. 2.7. The front face was of sheet aluminum and had a rectangular opening which allowed transmission of the thermal energy from the windows in the aperture plate to skin of the animal. The position of the rear face was adjustable so that the animal could be held against the aperture plate. Except for the greater length these containers were similar to those used at Operation GREENHOUSE.

#### 2.4.5 Ventilation and Heating

The ends of the double cylinders were closed with cast aluminum shutter housings having ventilation shutters which closed prior to the bomb detonation and reopened 2 to 3 minutes later. The shutter housing on one end of each unit was fitted with battery operated

UNCLASSIFIED

[REDACTED]

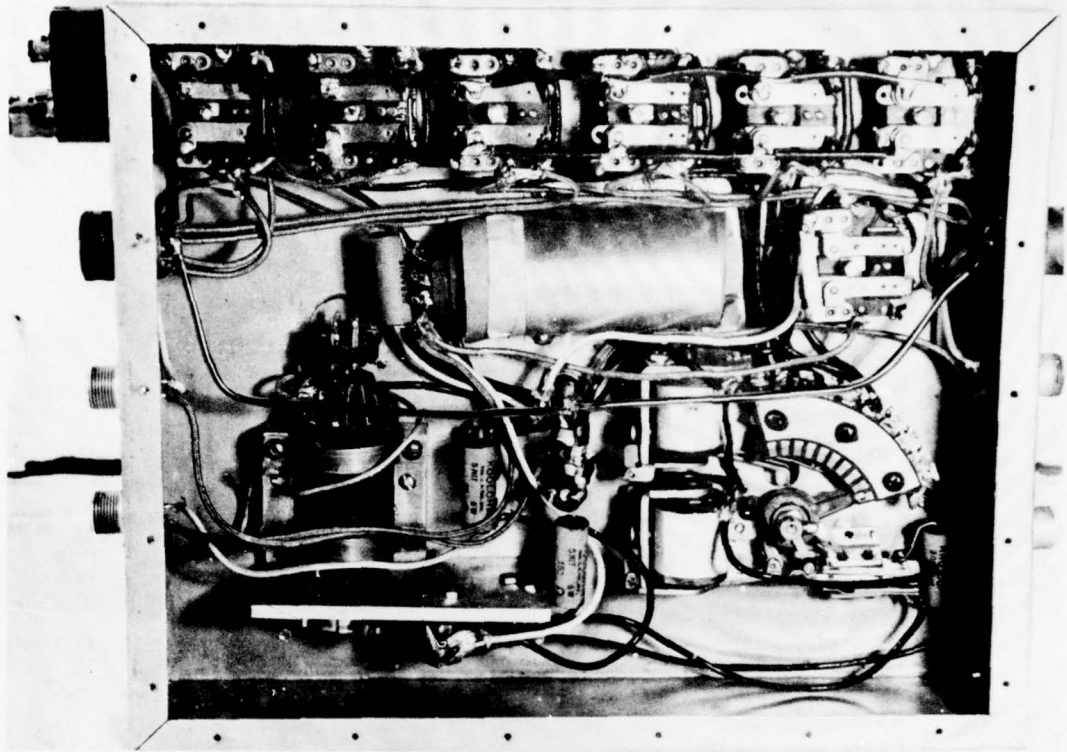

Fig. 2.6 Aperture Plate Timer with Bottom Cover Removed

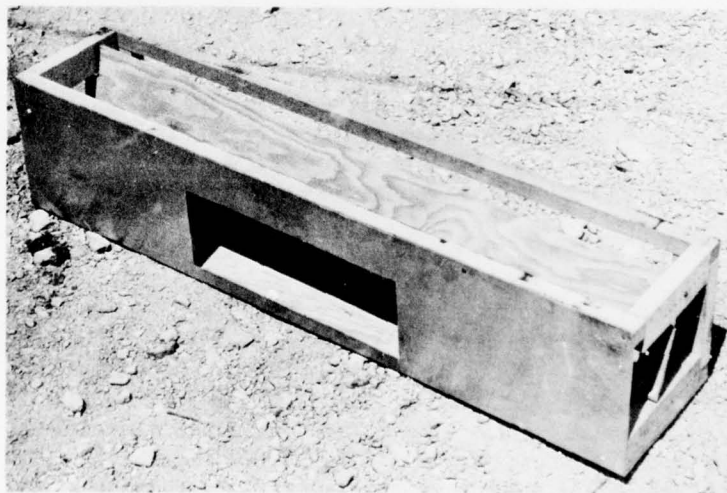

Fig. 2.7 Animal Container

[REDACTED]

[REDACTED]

UNCLASSIFIED

UNCLASSIFIED

~~CONFIDENTIAL~~  
information



Fig. 2.8 Cylindrical Thermal Exposure Unit with Shutter Housings Open Showing Animal Container, Heater and Ventilation Fans

ventilation fans which maintained a moderate flow of air through the exposure container, Fig. 2.8.

At the Pacific Proving Grounds where cooling was the only problem, the ventilation shutters were designed to provide the maximum airway both before and after the test. In Nevada, because of the low night temperature, the shutters were modified so that they were open only about  $\frac{1}{2}$  inch to restrict air flow until the minus 5 second signal at which time they were closed to protect the animal from blast. Following the blast they were ejected, as before, since by that time the ambient temperature had increased to a permissible level.

At night additional heating was provided by two 110-volt, 250-watt strip heaters secured directly to the inside of each liner-cage, and operated by central station power. One kilowatt of heating capacity was provided for each cylindrical thermal exposure unit, controlled by a thermostat which was set at 75 degrees F., and which held a differential of approximately 1 degree. The high thermal conductivity of the aluminum liner-cage distributed the heat effectively and improved its transfer to the air within the container. The ventilation fans produced sufficient mixing of the internal air to reduce the temperature differential between the top and bottom to about 1 degree.

~~CONFIDENTIAL~~  
ATOP

~~CONFIDENTIAL~~  
on

UNCLASSIFIED

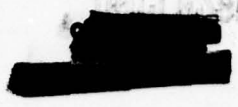

2.4.6 Batteries

Each double cylinder was treated as a separate unit so that failure of one component would not effect the others. Therefore each was supplied with its own 24-volt DC power supply to operate the ventilation fans and aperture plates. The ventilation shutters required about 1.5 amperes for many hours, requiring a minimum battery rating of 20 ampere-hours. The aperture plates required about 35 amperes for 10 seconds with good voltage regulation. Four 6-volt, 100 ampere-hour storage batteries were used to meet this requirement. The batteries were placed between the timbers of the skids, and covered with sand bags to avoid blast damage.

2.4.7 A-frame Containers

Comparison of large and small area burns on the same animal was achieved by suspending the animals in containers with openings in the front face. Two rugged A-frame supports were partially buried in the ground, and four of the animal exposure containers described in Paragraph 2.4.4 were suspended from them by steel cables. The front of each container (facing the bomb) was covered with a transite shield which had four 0.67 inch (1.7 cm) diameter round holes, and one 4 inch by 6 inch rectangular opening as shown in Fig. 2.9. At the time of placement of the animals, the containers were pulled forward until the front face was normal to the thermal radiation and held by light line. It was assumed that the line would burn or break allowing the cages to accelerate and absorb some of the energy due to the shock front.

2.4.8 Dust Covers

Because of the GREENHOUSE experience with dust collecting on the quartz windows of the aperture plate, it was thought desirable to take steps to protect against this in Operation SNAPPER. Accordingly, canvas covers were devised which were rigged under tension to cover the exterior of each aperture plate, Fig. 2.10. A magnetic trip described in Chapter 4 was connected to this dust cover and activated by a minus 5 second signal in such manner that the dust cover would be removed from the aperture plates before the bomb detonated.

2.5 EXPERIMENTAL PROCEDURE

Six cylindrical exposure units were placed two per station at three stations and two A-frame units at one station for Shots 3 and 4, Table 2.1 and Fig. 2.11.

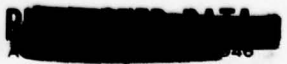
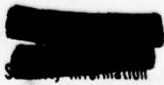

UNCLASSIFIED

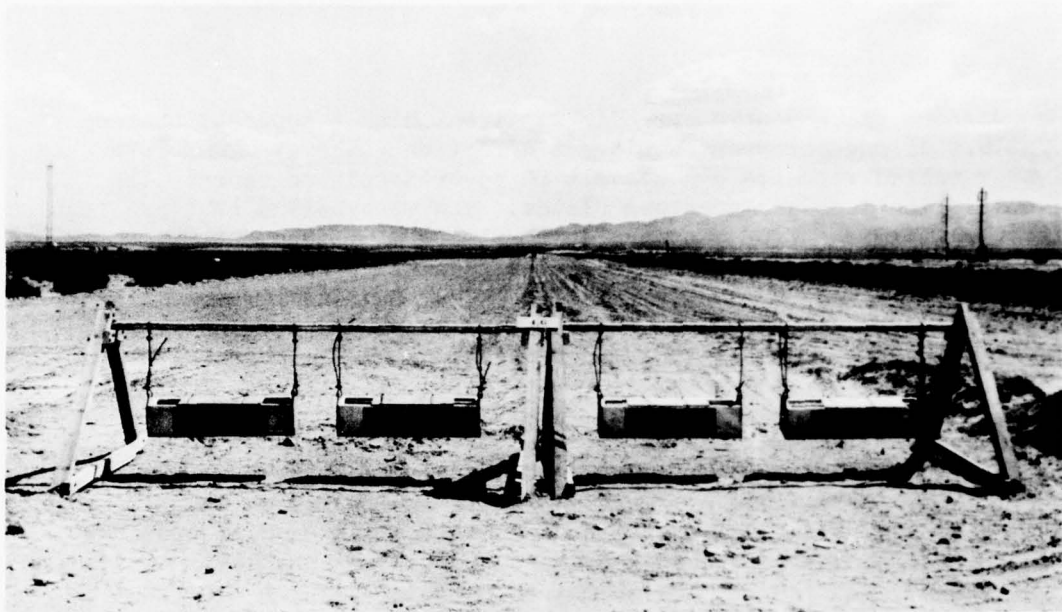

Fig. 2.9 A-frame Thermal Exposure Units

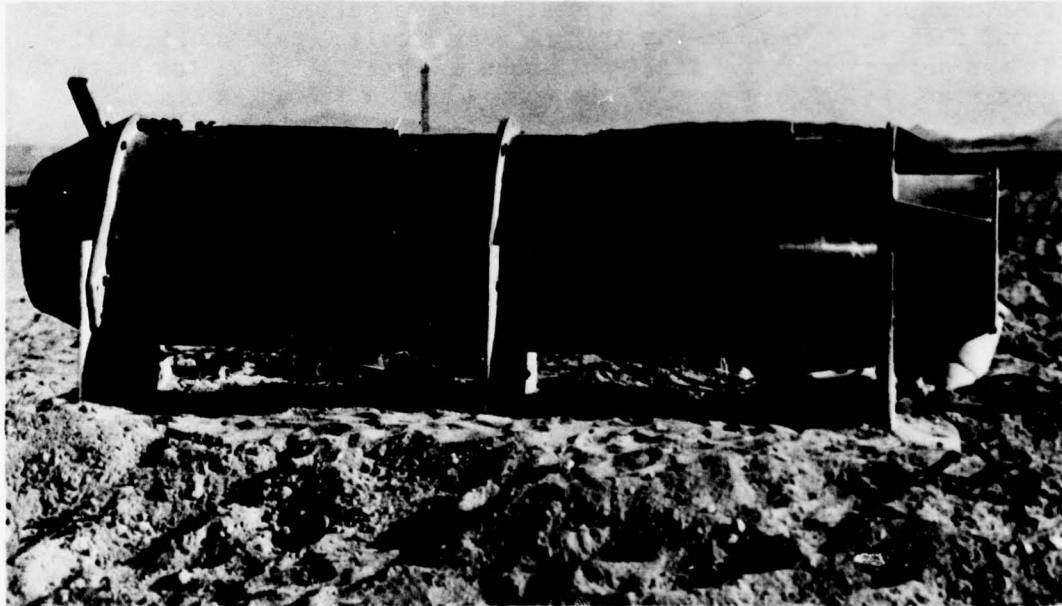
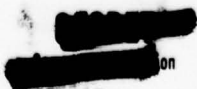
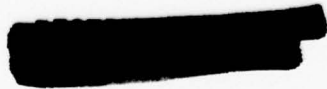

Fig. 2.10 Cylindrical Thermal Exposure Unit with Dust Covers in Place



UNCLASSIFIED

TABLE 2.1

## Location of Thermal Exposure Stations

Shot No.	Ground Range (feet)	Slant Range (feet)	Predicted Cal/cm <sup>2</sup>	Number of pigs used	Type of Container
3	3560	4955	30	4	Cylindrical
3	5150	6199	20	4	Cylindrical
3	7880	8601	10	4	Cylindrical
3	7880	8601	10	4	A-frame
4	3490	3642	30	4	Cylindrical
4	4200	4321	20	4	Cylindrical
4	5090	5195	14	4	Cylindrical
4	7780	7849	7	4	A-frame

Each aperture plate was adjusted to be normal to the direction of the bomb thermal radiation. The quartz windows were cleaned the day before the shot, and the dust covers then fitted. Due to last minute difficulties only two of these were used for Shot 3 and one failed to operate. In Shot 4, the covers were used until the time of placement of the animals and then removed manually.

All final preparations were made the afternoon before the shot with the exception of placing the animals and closing the battery circuit.

UNCLASSIFIED

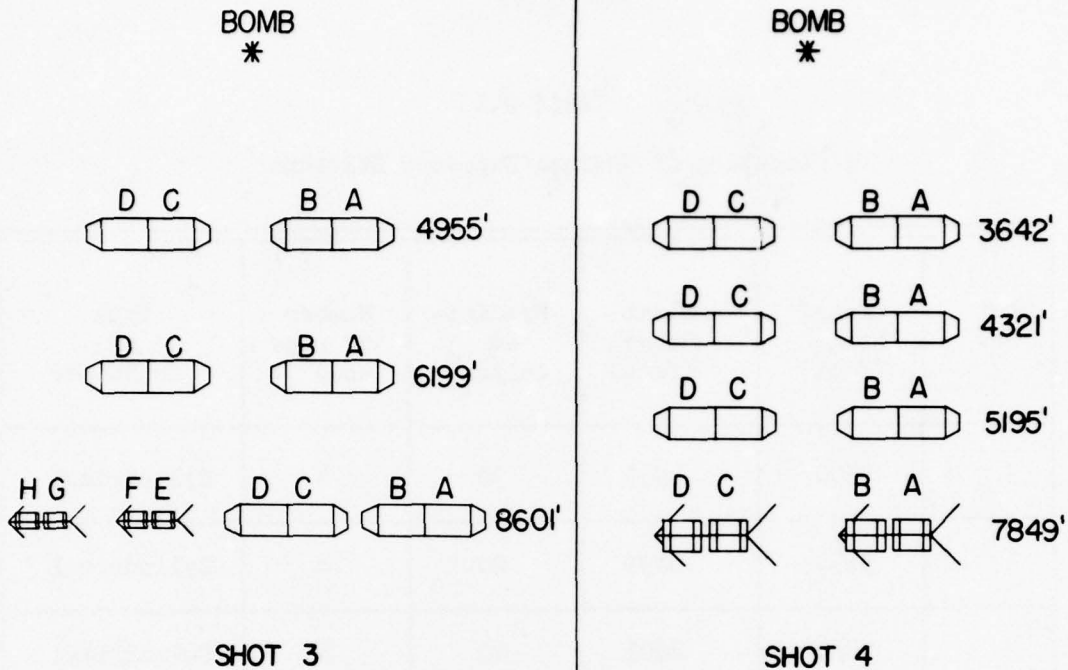

Fig. 2.11 Diagram of Locations of Thermal Exposure Equipment

Timers and ventilation shutters were set, and the 110-volt power was turned on in order that the containers would be warm at the time of animal placement.

Placement of animals was carried out at approximately 0400 on the day of the shot. At this time the batteries were connected, starting the ventilation fans, the dust covers were removed, and the quartz windows cleaned. Animal recovery was carried out as soon as the area was radiologically safe. Notes were made of evidence of damage, functioning, and non-functioning of equipment before anything was disturbed. The power was then disconnected and animals recovered. The general layout of a thermal container in block diagram style is shown in Fig. 2.12.

## 2.6 RESULTS

Performance of the thermal exposure equipment during the tests was generally satisfactory. The animals sustained no observable injury other than the flashburns. None of the equipment were damaged by blast or thermal radiation except for the sooting of some of the windows of two aperture plates. All heaters and fans and most of the ventilation shutters worked properly. All of the aperture plates and timers performed satisfactorily. Specific failures or defects are given in Table 2.2.

UNCLASSIFIED

TABLE 2.2

Specific Failures or Defects of Thermal Equipment

Specific Failure or Defect	Shot No.	Slant Range of Station (feet)	Number of Failures	Effect on Animals
1. Ventilation shutters failed to operate	3	6199	3	None
2. Dust cover failed to release	3	4955	1	No burns produced
3. Sooting of aperture plate windows	4	3642	2 aperture plates	Evaluation of burns unreliable

2.7 DISCUSSION

With the exception of one animal behind the dust cover which did not release, and the two animals behind the aperture plates which sooted, in which cases there is doubt of the validity of the burns, the biological results were satisfactory. The failure of several ventilating shutters to release did not effect the units since the outside temperature did not become high enough to produce any environmental stress.

Following Shot 3 the two most distant cylindrical exposure units were moved to new positions in preparation for Shot 4. This was accomplished with the minimum of time and labor confirming the practicability of mounting the exposure units on timber skids and sandbagging in position.

2.8 SUMMARY AND CONCLUSIONS

Twelve Operation GREENHOUSE cylindrical animal exposure containers were modified for use as thermal exposure units and substituted for the concrete and wooden shelters previously used. These units performed satisfactorily and had the additional advantage of portability.

UNCLASSIFIED

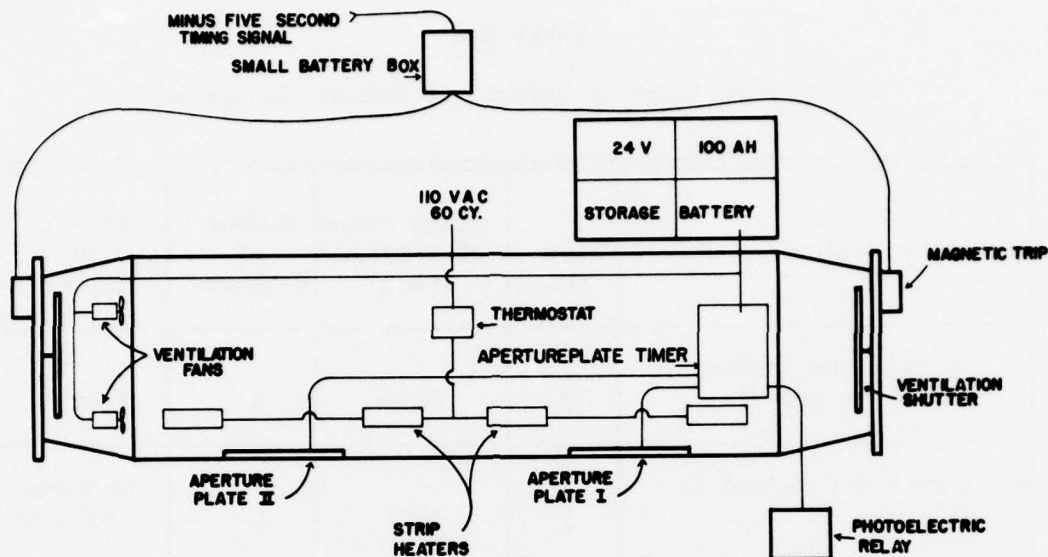

≠  
BOMB

Fig. 2.12 Block Diagram of Electrical Circuits of a Cylindrical Thermal Exposure Unit

Thirty-two young swine were exposed to thermal radiation on Shots 3 and 4 and a series of time vs intensity burns obtained.

## 2.9 RECOMMENDATIONS

Although the thermal exposure equipment discussed in this chapter functioned in a generally satisfactory manner, certain modifications are indicated if this type of equipment is to be used to perform a similar experiment.

It will be necessary to protect the gasketing of the quartz windows of the aperture plates from thermal damage. This could be accomplished by shielding the gaskets with a highly reflective material such as aluminum or making the gaskets from more thermally resistant material.

Automatically releasing dust covers would not be needed. The use of a dust cover up to the time of placement of animals proved to be entirely satisfactory.

UNCLASSIFIED

CHAPTER 3

RADIATION EXPOSURE EQUIPMENT

3.1 ABSTRACT

Single layered multiple compartment mouse cages, suitable for lethal dose type of study, have been designed and evaluated for variation in dose with position in the cage compartments by means of film and glass dosimeters.

These cages were exposed at five ranges each in Shots 3 and 4. The data have been treated by analysis of variance and no significant difference in dose was found.

High level exposure containers similar to the steel cylinders used at Operation GREENHOUSE were constructed of aluminum and tested at 300 to 600 feet in Shots 3, 4 and 5. These containers survived Shots 3 and 4 but collapsed at Shot 5 due to excessive pressure. Dosimeter readings of approximately 300,000 r maximum were recorded.

3.2 OBJECTIVE

It was the purpose of this study to measure the variation in gamma ray dose with position in a single layered multicompartment mouse cage which was a modification of the six layered multicompartment cage used in lethal dose studies during Operation GREENHOUSE.

A further objective was to determine the gamma ray dose in and blast resistance of aluminum high level radiation exposure containers which were a modification of the steel containers used during Operation GREENHOUSE.

3.3 INTRODUCTION

Lethal dose studies in mice during Operation GREENHOUSE were conducted in a 260 compartment multilayered mouse cage within cylindrical exposure containers 2/. Analysis of the mortality data indicated a variation in dose between front and rear layers. This variation was probably due to shielding of the rear layers by those in front.

In order to eliminate this source of error in gamma ray studies a single layered mouse cage was designed and evaluated by means of film and glass dosimeters for variation in dose within this layer.

At Operation GREENHOUSE biological materials were exposed to high

UNCLASSIFIED

UNCLASSIFIED

doses of gamma rays and neutrons in 6 inch diameter steel containers, embedded vertically in a concrete footing with 1 foot of their length above ground 2/.

In order to reduce the attenuation of radiation caused by the heavy steel walls of these containers they were redesigned and constructed entirely of aluminum. Vycor glass dosimeters were used to measure ionizing radiation.

#### 3.4 DESCRIPTION OF EQUIPMENT

Operation GREENHOUSE cylindrical animal exposure containers mounted on timber skids as described in 1.4 were used for the exposure of single layered mouse cages, Fig. 3.1

These cages were constructed of 1/4 inch plywood having perforated metal covers. The cage was divided into 96 separate compartments arranged in eight rows and 12 columns each having inside dimensions of 2 x 2 1/4 x 3 inches.



Fig. 3.1 Single Layer Multicompart ment Mouse Cage Positioned in Animal Exposure Container

UNCLASSIFIED

Two types of dosimeters were used to evaluate the gamma ray dose in various compartments of the mouse cage. Mouse "phantoms" were assembled by using two unshielded Adlux films alternately placed between three  $1\frac{1}{4} \times 1\frac{3}{4} \times 2\frac{1}{4}$  inch masonite blocks. The other type was the silver phosphate glass personnel dosimeter in its plastic locket 4/.

The high level radiation exposure containers were constructed of aluminum having roughly the same dimensions as the steel containers used at Operation GREENHOUSE. They were 6 inches in diameter and 30 inches long having a threaded aluminum cap. These cylinders were welded to a base plate and heavily braced. The plate was bolted to a timber frame and the unit buried in the ground having 1 foot of the cylinder exposed, Fig. 3.2.

### 3.5 EXPERIMENTAL PROCEDURE

Cylindrical exposure containers were placed at 1200, 1500, 2100, 2700 and 3300 feet from ground zero on the Bio-medical line in Shot 3, and at 3500, 4000, 4500, 5000 and 5500 feet in Shot 4. Placement of the mouse cages was accomplished on the day before each test and recovery effected a few hours after each shot. All of the dosimeters were sent



Fig. 3.2 High Level Radiation Exposure Container

UNCLASSIFIED

[REDACTED]

to the Naval Medical Research Institute where they were read at a later time. Each mouse cage within its exposure cylinder was inclined sufficiently to bring the front face normal to the direction of the bomb.

Due to the limited number of dosimeters available a pattern of three columns and four rows was selected for placing the films and two columns and four rows for the glass dosimeters. This pattern is shown in Fig. 3.3.

Four high level exposure containers were placed at 300, 400, 500 and 600 feet from ground zero for Shots 3, 4 and 5. Vycor rod dosimeters were placed in each of the containers several days before the tests. Since the dosimeters were not appreciably affected by remaining in the containers, recovery was delayed until the areas were radiologically safe.

3.6 RESULTS

Mouse phantom film and glass dosimeter data are given in Tables 3.1 and 3.2. Columns are designated by the symbol X, rows by Z, and stations by Y. Since two mouse phantoms were placed at each location

					X <sub>1</sub>		X <sub>2</sub>		X <sub>3</sub>	
Z <sub>1</sub>					Films	Glass	Films	Glass	Films	
Z <sub>2</sub>					Films	Glass	Films	Glass	Films	
Z <sub>3</sub>					Films	Glass	Films	Glass	Films	
Z <sub>4</sub>					Films	Glass	Films	Glass	Films	

Fig. 3.3 Pattern of Dosimeters in Mouse Cage

[REDACTED]

[REDACTED]

UNCLASSIFIED

the additional symbol A is employed to identify the two members of the pair.

An analysis of variance <sup>5/</sup> was carried out on the mouse phantom data using the variance between pairs as the error term. The results are given in Table 3.3. It will be noted that, with the exception of one interaction term, only the "F" ratios for station are significant. In other words, no significant variation in dose with location inside the mouse cage exists.

The same conclusions may be drawn from the glass dosimeter data, Table 3.4, although no pairs of readings were available for an error term and it was necessary to use the triple interactions variance for this purpose. It will be noted that some of the "F" ratios for both mouse phantom and glass dosimeters are smaller than predicted by theory. Analysis of the data, station by station, did not yield an explanation of the anomalies.

Mean values of the dose, standard error of the mean and degrees of freedom are given in Table 3.5. Comparison between film and glass dosimeter values indicates that the films in the phantom at the nearer stations were overexposed.

The high level vycor glass dosimeter readings are given in Table 3.6. This table includes data from Shots 3 and 4 only since Shot 5 dosimeters were lost due to the collapse of the containers, from excessive pressure.

### 3.7 DISCUSSION

The accuracy of individual film or dosimeter readings is relatively low but when all readings are properly grouped and appropriately treated the result is quite reliable. It is estimated that a variation in dose of 3 to 5 per cent could readily have been detected. This is within present requirements of biological research such as lethal dose studies. It is of interest to note that this "purely physical" data can best be handled by methods of analysis frequently applied in biology.

The attempt to design a high level exposure container of aluminum in order to increase its transparency to gamma rays was in general satisfactory. The data available does not permit accurate estimates of pressure at these close ranges. Rough extrapolation of the peak pressure curves given on page 5 of "Capabilities of Atomic Weapons" Revised Edition 1 October 1952 indicates that the steel containers at Operation GREENHOUSE Test Easy received about 200 psi at the 900-foot station. For Shot 4 at the 300-foot station the aluminum container received about

UNCLASSIFIED

UNCLASSIFIED

TABLE 3.1

Film and Glass Dosimeter Readings  
by Station and Location, Shot 3

Ground Range (feet)	Row Z	Column							
		Film						Glass	
		X <sub>1</sub>		X <sub>2</sub>		X <sub>3</sub>		X <sub>1</sub>	X <sub>2</sub>
1200	1	860	850	950	800	830	880	1704	1688
	2	780	815	835	860	870	860	1635	1698
	3	815	850	860	850	835	830	1615	1595
	4	825	880	835	850	770	835	1605	1685
1500	1	800	780	850	870	815	800	1505	1436
	2	815	815	835	780	835	815	1375	1471
	3	790	770	780	835	835	790	1456	1393
	4	790	740	790	800	830	800	1426	1436
2100	1	715	725	750	700	735	735	1096	1078
	2	735	750	760	740	750	740	1005	1062
	3	735	750	750	715	715	735	1151	1057
	4	760	750	735	725	740	750	1074	1091
2700	1	740	590	640	580	620	640	695	802
	2	650	650	600	650	660	650	798	762
	3	660	585	610	630	650	660	814	623
	4	610	590	610	610	600	620	676	762
3300	1	420	418	385	400	418	395	447	439
	2	420	430	418	400	408	418	466	459
	3	440	430	410	408	408	400	458	446
	4	408	385	408	400	390	395	516	442

100 psi and survived. At Shot 5 the most distant station at 600 feet received approximately 200 psi but the container did not survive.

3.8 CONCLUSIONS

Variation in gamma ray dose observed in Operation GREENHOUSE multi-layer, multicompart ment mouse cage has been eliminated by the substitu-

AT 1946

[REDACTED]

UNCLASSIFIED

UNCLASSIFIED

tion of a single layer multicompartiment cage.

The aluminum high level exposure containers were satisfactory at about 100 psi but collapsed at around 200 psi. No data are available for intermediate pressures.

TABLE 3.2

Film and Glass Dosimeter Readings  
by Station and Location, Shot 4

Ground Range (feet)	Row Z	Column							
		Film						Glass	
		X <sub>1</sub>		X <sub>2</sub>		X <sub>3</sub>		X <sub>1</sub>	X <sub>2</sub>
3500	1	900	870	860	930	980	930	1627	1682
	2	970	900	870	870	940	900	1452	1653
	3	940	890	920	940	870	890	1445	1665
	4	870	890	880	880	950	930	1625	1560
4000	1	700	670	770	735	660	680	800	829
	2	680	715	715	650	700	620	941	877
	3	680	680	690	715	630	660	745	852
	4	660	680	700	620	640	680	895	875
4500	1	395	385	420	418	440	430	456	444
	2	400	395	420	400	420	430	420	413
	3	408	430	395	408	410	430	473	473
	4	410	400	408	400	410	418	448	427
5000	1	220	228	220	215	218	215	173	227
	2	230	230	218	220	215	215	155	193
	3	232	235	218	208	220	218	170	216
	4	218	215	215	210	215	212	193	205
5500	1	108	107	113	108	115	112	75	121
	2	115	110	112	117	113	108	102	125
	3	112	108	117	113	107	107	125	122
	4	112	105	110	112	107	103	110	95

UNCLASSIFIED

UNCLASSIFIED

TABLE 3.3

Analysis of Variance, Film Dosimeter Readings, Shots 3 and 4

Factor	Symbol	Sum of Square Deviations	Degrees of Freedom	Variance	F	Significant
<u>Shot 3</u>						
Columns	X	470	2	235	0.30	No
Stations	Y	2,918,116	4	729,529	939.00	Yes
Rows	Z	6,780	3	2,260	2.91	No
Interactions:						
Double	XY	7,331	8	916	1.18	No
Double	XZ	2,371	6	395	0.51	No
Double	YZ	9,598	12	800	1.03	No
Triple	XYZ	13,849	24	577	0.74	No
Error	A	46,620	60	777	X	No
<u>Shot 4</u>						
Columns	X	21	2	11	0.03	No
Stations	Y	10,340,703	4	2,585,176	6,747.00	Yes
Rows	Z	2,747	3	916	2.39	No
Interactions:						
Double	XY	12,612	8	1,577	4.12	Yes
Double	XZ	6,771	6	1,129	2.95	No
Double	YZ	3,047	12	254	0.66	No
Triple	XYZ	15,262	24	636	1.66	No
Error	A	22,970	60	383	X	No

RECOMMENDED  
ATC

UNCLASSIFIED

UNCLASSIFIED

TABLE 3.4

Analysis of Variance, Glass Dosimeter Readings, Shots 3 and 4

Factor	Symbol	Sum of Square Deviations	Degrees of Freedom	Variance	F	Significant
<u>Shot 3</u>						
Columns	X	212	1	212	0.08	No
Stations	Y	7,647,763	4	1,911,941	757.00	Yes
Rows	Z	4,065	3	1,355	0.54	No
Interactions:						
Double	XY	2,904	4	726	0.29	No
Double	XZ	18,639	3	6,213	2.46	No
Double	YZ	19,824	12	1,652	0.65	No
Triple	XYZ	30,307	12	2,526	X	
<u>Shot 4</u>						
Columns	X	9,425	1	9,425	4.52	No
Stations	Y	7,775,613	4	1,943,903	931.00	Yes
Rows	Z	1,591	3	530	0.25	No
Interactions:						
Double	XY	15,003	4	3,751	1.80	No
Double	XZ	11,688	3	3,896	1.87	No
Double	YZ	33,900	12	2,825	1.35	No
Triple	XYZ	25,039	12	2,087	X	

UNCLASSIFIED

UNCLASSIFIED

TABLE 3.5

Mean Dosimeter Readings, Shots 3 and 4

Shot Number	Ground Range (feet)	Film			Glass		
		Mean (r)	Standard Error	Degrees Freedom	Mean (r)	Standard Error	Degrees Freedom
3	1200	843	7.3	23	1653	16	7
3	1500	807	5.9	23	1437	15	7
3	2100	737	3.1	23	1077	15	7
3	2700	631	7.2	23	742	24	7
3	3300	409	2.9	23	459	9	7
4	3500	907	7.1	23	1589	33	7
4	4000	680	7.3	23	852	21	7
4	4500	411	2.9	23	444	8	7
4	5000	219	1.4	23	193	8	7
4	5500	110	0.8	23	109	6	7

UNCLASSIFIED

TABLE 3.6

Vycor Glass Dosimeter Readings in High Level Radiation  
Exposure Containers, Shots 3 and 4

Ground Range (feet)	Roentgens (Equivalent to Cobalt <sup>60</sup> Gamma)	
	Shot 3	Shot 4
300	2840	Lost
400	1730	300,000
500	2060	220,000
600	1990	300,000

UNCLASSIFIED

UNCLASSIFIED

CHAPTER 4

INSTRUMENTATION

4.1 ABSTRACT

A number of instruments or devices for use with animal exposure equipment have been designed and prototypes tested for satisfactory performance. In most cases these devices were the outcome of observations or needs arising at Operation GREENHOUSE. These devices include photoelectric relay, air blast overpressure relay, ground shock relay, silicone timer, magnetic trip, oscillograph evaluation of instrument performance, motion picture camera, time delay relay, and battery power supply.

4.2 INTRODUCTION

The exposure of animals to atomic bomb effects including blast, thermal and ionizing radiation requires highly specialized exposure equipment which must be actuated, controlled and instrumented by various devices. A number of such devices were utilized for Operation GREENHOUSE at which time the need for several others became apparent. Since this project was largely concerned with the design of equipment rather than the exposure of animals, the opportunity was afforded to test prototypes of a variety of instruments and actuating devices without jeopardizing a biomedical program.

Advantage may be taken of the electromagnetic phenomena of the bomb including gamma rays, light, heat and radio waves to provide an immediate signal approximating zero time. Blast effects such as ground shock or air blast may be used for delayed signals within certain limits.

4.3 INSTRUMENTS

This chapter discusses the design, construction and performance of nine instruments. In order to avoid confusion, all information pertaining to each instrument is included under the title of that instrument instead of being divided into separate sections.

4.3.1 Photoelectric Relay

Photoelectric relays were used to initiate the aperture plate timers which needed a zero time signal with an accuracy of a few milliseconds, a requirement which could not be met by the wired timing signals. Other instruments such as blast recorders could also more readily be activated by this device in locations where wired timing

UNCLASSIFIED

UNCLASSIFIED

signals were difficult to provide since this unit was reliable, small, self-contained and did not require an external power supply.

Figure 4.1 shows the exterior appearance of the photoelectric relay. The housing was a heavy walled cast aluminum waterproof junction box, Navy issue number 17-B-29680. The circuit includes a small vacuum type phototube, a miniature cold-cathode thyatron, a subminiature sealed relay, and associated components, Fig. 4.2. All these components were potted in transparent plastic to improve waterproofing, and resistance to shock and handling. The power supply consisted of a 135-volt miniature B-battery. The potted unit and battery were housed in the junction box, and the reset button mounted on top. Light access was through a window in the side of the box and two pieces of fine metallic screen with a combined transmission of 4 per cent. The screen was necessary to prevent damage to the phototube by the high intensity flash and blocking by direct sunlight.

The circuit is sensitive only to high intensity light with a very short rise time, and not to steady illumination regardless of intensity. The input circuit of the thyatron has a time constant of 0.47 msec. In operation, the thyatron fires when it receives a sufficiently strong signal on the grid. This closes the relay, and the circuit remains conducting until the reset button is pushed. In the non-conduct-



Fig. 4.1 Photoelectric Relay

59

UNCLASSIFIED

UNCLASSIFIED

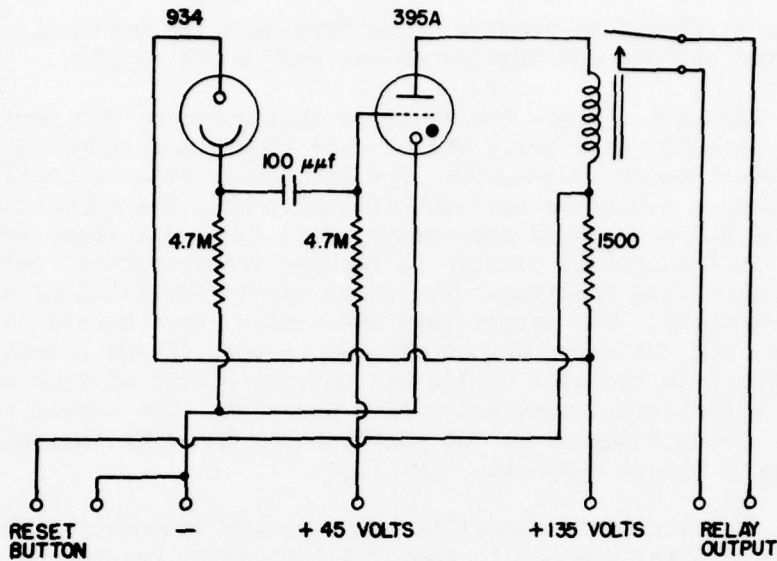

Fig. 4.2 Circuit Diagram of Photoelectric Relay

ing state, the only load on the battery is through the phototube, and therefore depends on ambient illumination. This drain is only about 5 microamperes under average illumination, and hence the life of the battery approaches shelf life. No switch is needed to disconnect the battery when the unit is not in use.

All units functioned properly. At the close-in stations, a hole was burned through the outer metallic screen but the phototube was not damaged. Since the area could not be entered for several hours the batteries were partially exhausted before the relay could be reset. This necessitated replacement of the batteries for successive tests.

Certain modifications of the phototube relay appear desirable. The circuit should be modified to be self-resetting after an appreciable fraction of a second if it would not add significantly to the complexity of the unit. This would obviate the need for a reset button, time and expense of replacing batteries, would permit simpler testing procedure, and reduce the chance of human error. If a hemispherical window of translucent material mounted in the top of the relay housing were substituted for the plane window in the side of the housing, orientation would be less critical and installation greatly simplified. If the material of the dome had a sufficiently low light transmission, the filter screens could be eliminated.

UNCLASSIFIED

UNCLASSIFIED

4.3.2 Air Blast Overpressure Relay

The air blast overpressure relay, Fig. 4.3, is a device for closing an electrical circuit upon the arrival of the air pressure wave. This relay was tested for performance but not used to actuate exposure equipment. It can be used to anticipate the arrival of the air pressure wave at a point beyond its location. This device could be used to initiate action temporarily related to the shock front.

The housing was the same as described for the photoelectric relay. The essential components of the relay include a pressure sensitive metal diaphragm, microswitch, latching relay, fuse, and battery. The diaphragm was attached to the housing cover by two brass rings. The microswitch was mounted beneath the diaphragm, and adjusted so that an increase in pressure of 1 psi closed the circuit. The electrical circuit of the relay is shown in Fig. 4.4. Current drain from the battery occurs only during the short interval between closing of the microswitch and operation of the latching relay. Resetting of the relay is necessary before reuse.

Overpressure relays were tested at Shots 4, 5 and 8 at ranges from 800 to 5700 feet. In general the performance was satisfactory when the sensitivity was adjusted to about 1 psi. Several of

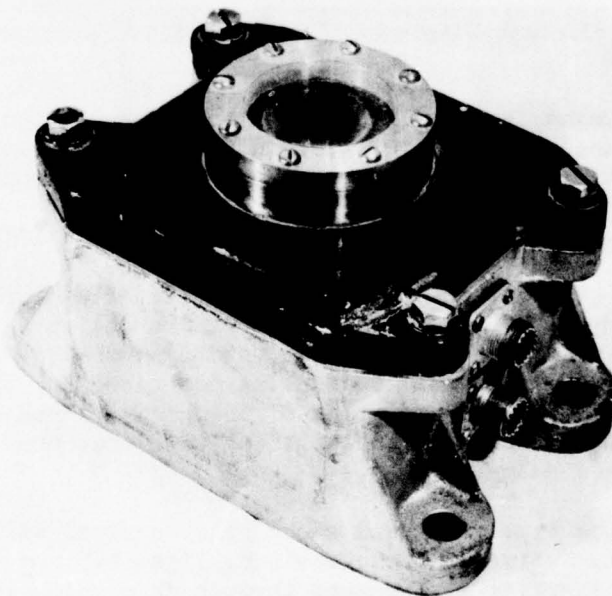
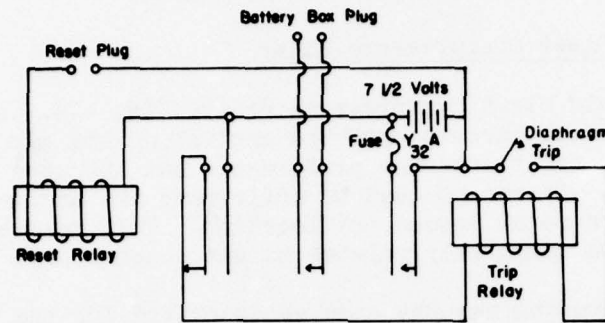

Fig. 4.3 Air Blast Overpressure Relay

UNCLASSIFIED

UNCLASSIFIED

OPEN LATCH-TYPE RELAY



CLOSED LATCH-TYPE RELAY

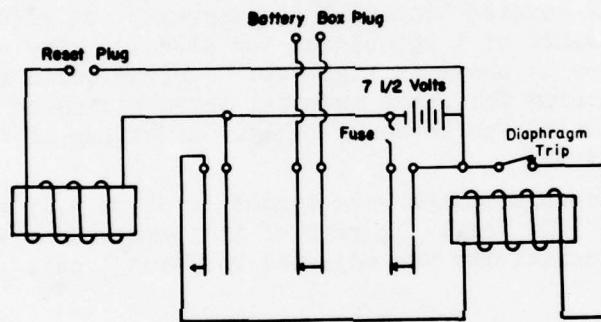

Fig. 4.4 Circuit Diagrams of Air Blast Overpressure Relay

the metal diaphragms, exposed to direct thermal radiation, were burned indicating the need for a thermal shield. The circuit would be improved by a self resetting feature as discussed under photoelectric relays.

4.3.3 Ground Shock Relays

The ground shock relays were devices for closing an electrical circuit upon the arrival of the ground shock wave. These relays were tested for performance and used to start several overpressure recorders. The housings were the same as described for the photoelectric relays. With the exception of the ground shock sensing mechanism, the electrical circuit is identical with that used for the air blast overpressure relay, Fig. 4.4.

In one type of ground shock relay a steel ball was supported in a cylindrical housing on a microswitch, Figs. 4.5 and 4.6. In the other, a weighted spring wire passed through an opening in a metal plate, Fig. 4.7. Acceleration of either mechanism caused a momentary closure of the electrical circuit.

UNCLASSIFIED

UNCLASSIFIED

[REDACTED]

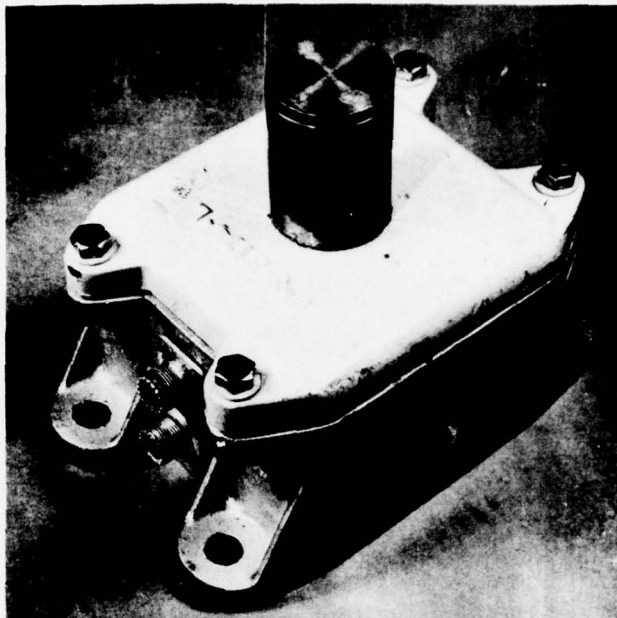

Fig. 4.5 Ground Shock Relay, Ball Type

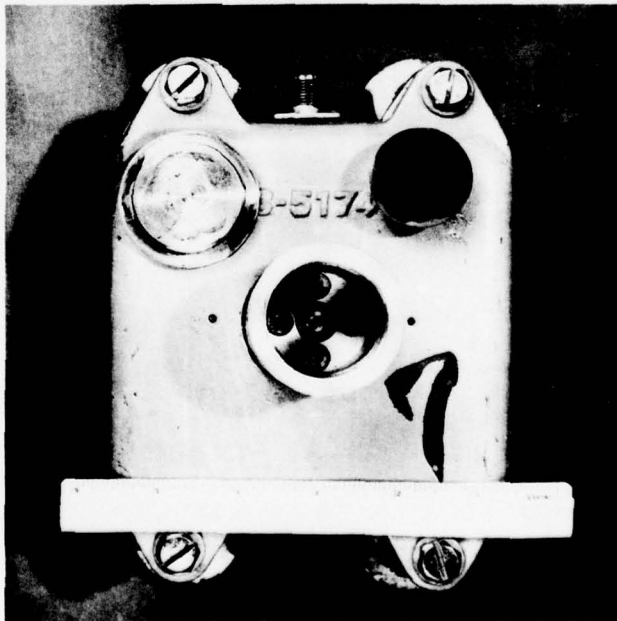

Fig. 4.6 Ground Shock Relay, Ball Type, With Cap and Ball Removed

[REDACTED]

[REDACTED]

UNCLASSIFIED

UNCLASSIFIED

~~Security Information~~

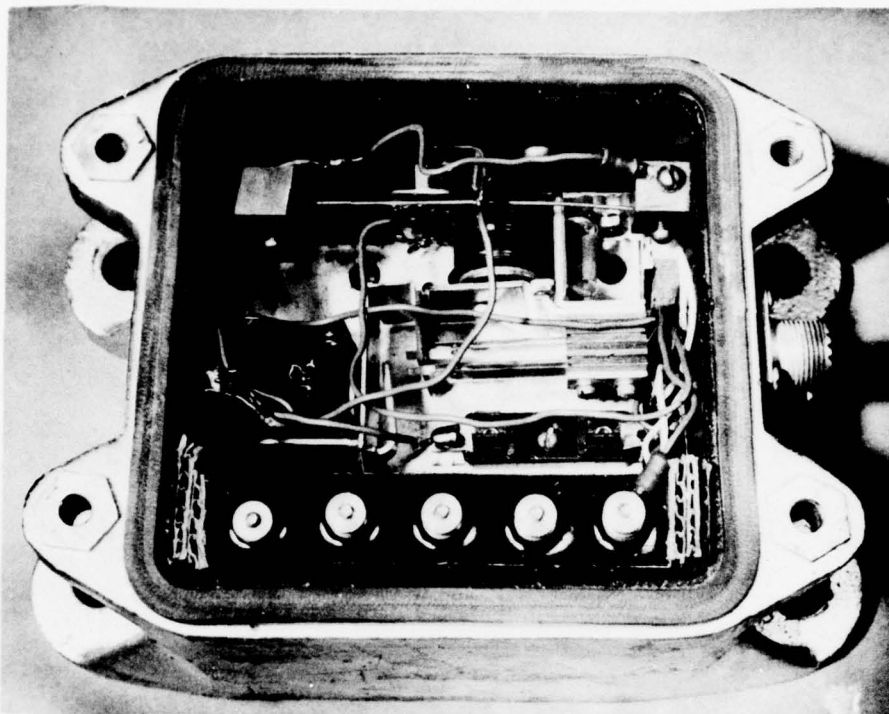

Fig. 4.7 Ground Shock Relay, Arm Type, With Cover Removed

The ground shock relays were tested at Shots 3, 5 and 8 between the ranges of 800 and 5700 feet. They did not operate reliably, particularly at the more distant stations, apparently due to lack of sensitivity. Increasing the sensitivity, however, is not a desirable feature since it increases the possibility of premature function due to local shock.

#### 4.3.4 Silicone Oil Timer

At Operation GREENHOUSE the timing of the reopening of the ventilation shutters for the cylindrical animal exposure containers was controlled by a lever which slowly cut through a viscous wax slug releasing the shutter in 1 to 2 minutes  $\frac{2}{3}$ . While this wax timer operated successfully in this situation, it had the undesirable feature of being temperature dependent. In order to overcome this defect, a silicone oil timer, Figs. 4.8 and 4.9, was designed and used for the thermal exposure units described in paragraph 2.4.5, for which application they performed satisfactorily.

This device consists of a hydraulic cylinder, piston, and piston rod, completely filled with silicone oil. A small aperture in

UNCLASSIFIED

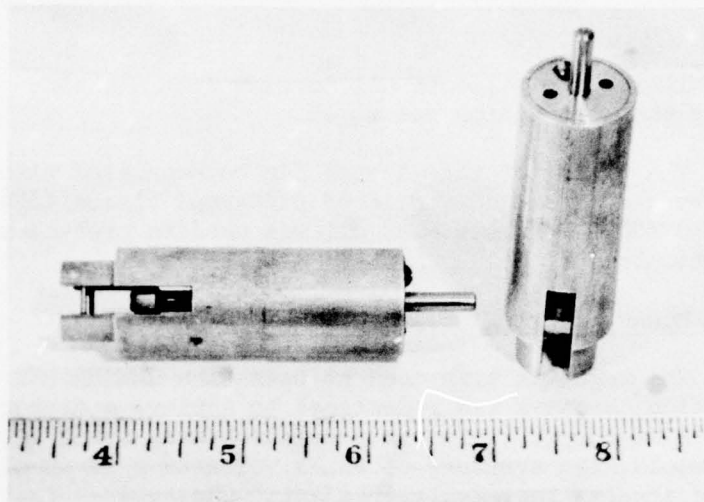

Fig. 4.8 Silicone Oil Timer

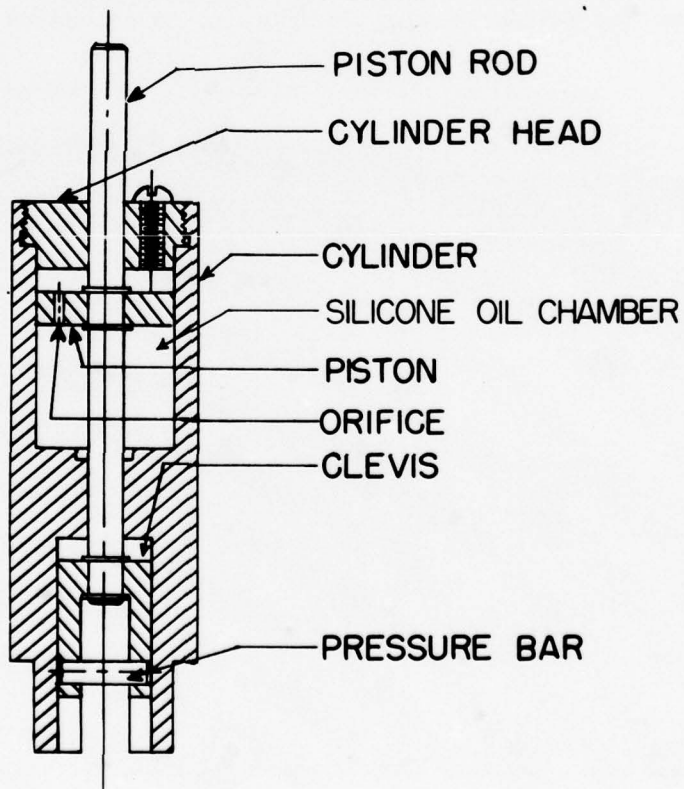

Fig. 4.9 Sectional View of Silicone Oil Timer

UNCLASSIFIED

UNCLASSIFIED

the piston allowed the silicone oil to flow from one side of the piston to the other when the piston was moved.

The timing of this device can be regulated within wide limits by the use of silicone oils of different viscosities. A mixture of 60,000 and 100,000 centistokes oil was used to produce a time delay of about 3 minutes.

#### 4.3.5 Magnetic Trip

The magnetic trip used at Operation GREENHOUSE to release the ventilation shutters was redesigned to achieve a higher impulse with lower input power. This was accomplished by means of a 0.1 ampere, 24-volt solenoid, the armature of which released a lever allowing a spring urged plunger forcefully to eject. The general features of this device are shown in Figs. 4.10 and 4.11. They were used to release the ventilation shutters of the thermal exposure units as described in 2.4.5. The open construction of these magnetic trips was not satisfactory at the Nevada Proving Grounds due to excessive dust.

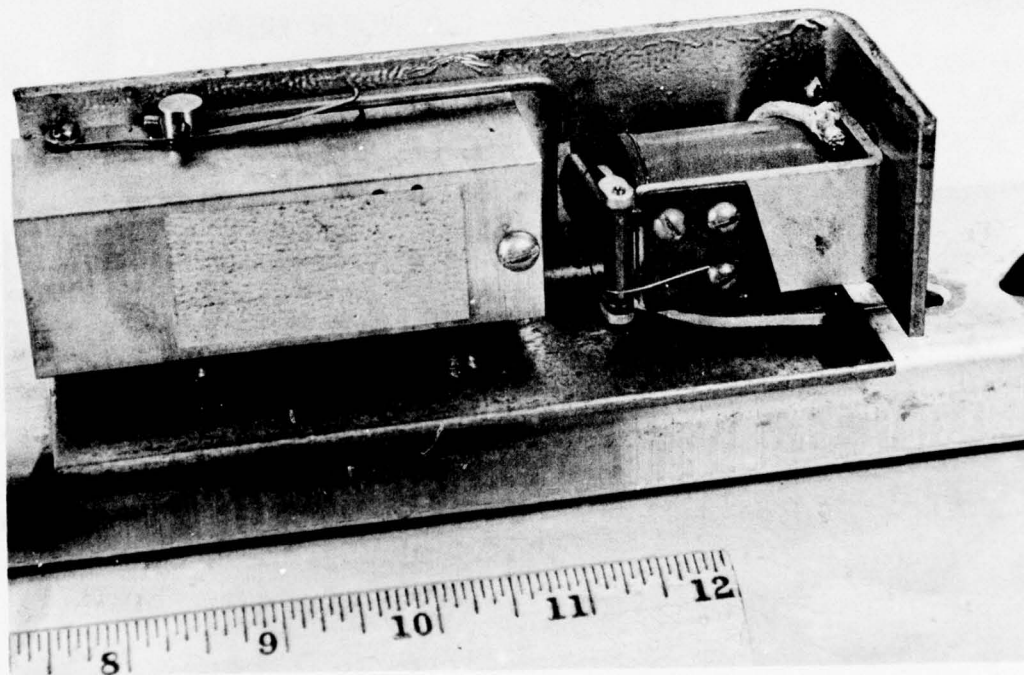

Fig. 4.10 Magnetic Trip

AT [REDACTED]

SECRET

UNCLASSIFIED

UNCLASSIFIED

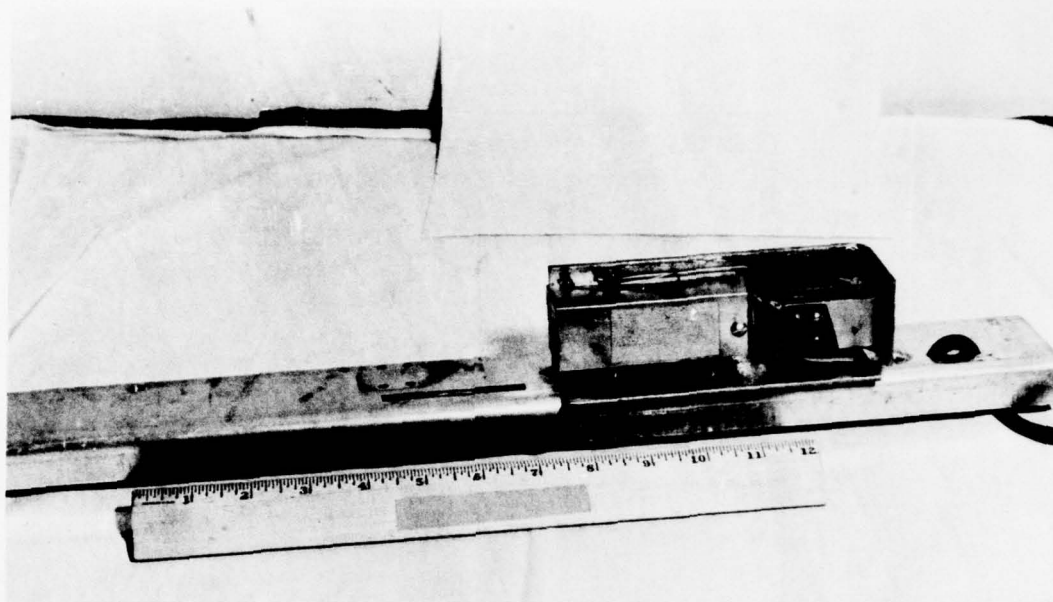

Fig. 4.11 Magnetic Trip Attached to Shutter Bar

#### 4.3.6 Time Delay Relay

Occasionally signals are needed at times between or beyond standard time signals in connection with the operation of biomedical equipment. A time delay relay was therefore included among the instruments evaluated.

This relay was housed in a cast aluminum case together with its power supply. Connections for input and output were provided. The electrical circuit is shown in Fig. 4.12. The range of the time delay was 0.1 to 10 seconds. An example of the operation of this relay is given in Table 4.1

#### 4.3.7 Oscillograph Record of Instrument Performance

Experience at Operation GREENHOUSE indicated that it is not always possible to properly evaluate the performance of remotely or automatically operated equipment when only the end result can be observed. In Operation SNAPPER it was decided to obtain a direct time-base record of the performance of various instruments described in this report.

A 14 channel recording oscillograph, Model 555A, having a paper speed of 10 inches per second and resolution time of 0.01 second, procured from the Midwestern Geophysical Laboratories. Nine channels

UNCLASSIFIED

UNCLASSIFIED

UNCLASSIFIED

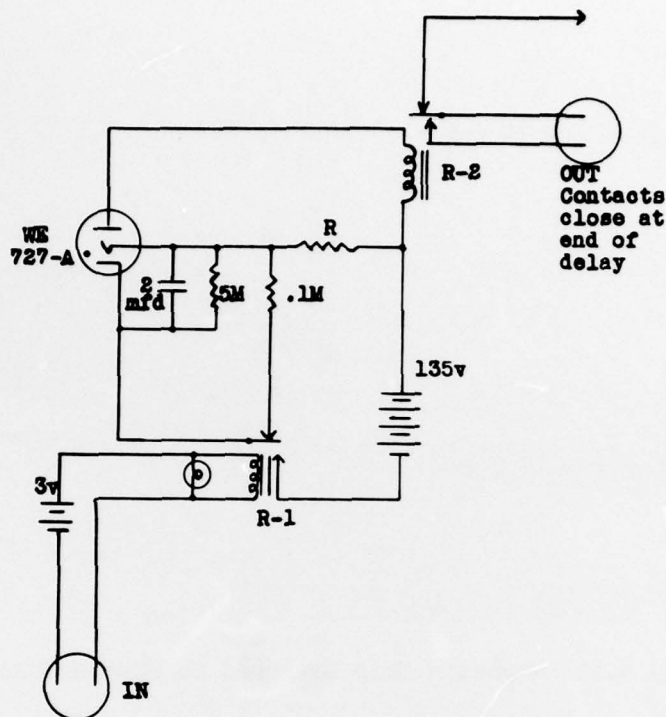

Fig. 4.12 Circuit Diagram of Time Delay Relay

were connected to the instruments listed in Table 4.1.

The oscillograph and power supply were placed in a heavy wooden box at 1500 feet ground range in Shot 3, buried in the ground and covered with 1 foot of sandbags and dirt. At this distance the gamma ray shielding was insufficient and the record was fogged beyond use.

In Shot 4 the oscillograph and power supply were buried in the ground and covered with 3 feet of sandbags and dirt at 4000 feet ground range. The record was only slightly fogged and could easily be read.

The results are given in Table 4.1. The response of the photoelectric relay being very rapid was assumed to indicate zero time from which all other signals were measured. The ground shock relays failed to operate at this distance. It will be noted that the over-pressure relays placed 200 feet apart recorded 0.20 second difference, which indicated a ground speed of 1000 feet per second for this air shock wave.

UNCLASSIFIED

TABLE 4.1

Oscillograph Record of Instrument Performance,  
4000 Feet Ground Range, Shot 4

Channel	Instrument	Actuated by	Response Time (Sec.)
1.	Photoelectric relay	Bomb flash	0.00
2.	Time delay relay (1.0 sec.)	Photoelectric relay	+ 0.98
3.	Shutter, thermal tripped <sup>2</sup>	Bomb flash	+2.18
4.	Shutter, solenoid tripped	Photoelectric relay	+0.04
5.	Ground shock relay (ball)	Ground shock	--
6.	Ground shock relay (arm)	Ground shock	--
7.	Overpressure relay at 4000 ft.	Overpressure	+2.20
8.	Overpressure relay at 4200 ft.	Overpressure	+2.40
9.	Time delay relay (4.0 sec.)	Minus 5 sec. signal	-1.03

#### 4.3.8 Motion Picture Cameras

Motion picture cameras were used to record the action of exposure equipment such as aperture plates, ventilation shutters and open mesh cages.

Gun synchronized aerial photographic cameras were modified by disconnecting the heater and mounting them in waterproof, cast aluminum junction boxes, Fig. 4.13. A 7/16 inch thick quartz window was provided opposite the camera lens. Each camera could be fitted with

UNCLASSIFIED

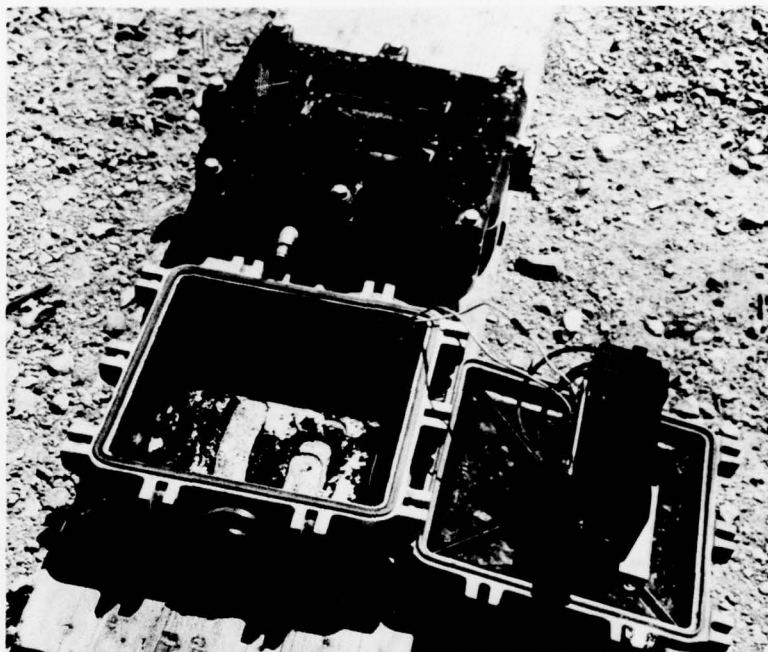

Fig. 4.13 Motion Picture Camera with Cover Open

a neutral density one, two, or three filter in order to provide proper exposure for any phase of the bomb illumination. Each camera was used in conjunction with a battery box containing a 30-volt dry battery and associated electrical components. The battery box was so connected that a momentary closure of the input circuit would start the camera, and this circuit would open approximately 30 seconds later. The camera used a 50-foot magazine of 16 millimeter film, and this was run at 64 frames per second, which resulted in approximately 30 seconds running time.

In use, a camera with battery box was bolted to the end of a 10-foot plank, Fig. 4.14. The front end of this plank was raised on sandbags to aim the camera. Sandbags were placed over the top of the camera, battery box, and remainder of the plank to a thickness of 2 feet and covered with dirt to prevent burning. The cameras were started by the minus 5 second timing signal. This allowed adequate time for the cameras to come up to operating speed, and also to record events before the shot in cases where exposure was made by natural illumination. In most instances the cameras were used in pairs, sometimes with one set for natural illumination and the other for bomb illumination, and in other cases with one camera exposing for early and the other for late bomb illumination. A typical camera installation is shown in Fig. 4.15. Film recovery was made as soon as possible after the shot in order to minimize radiation fogging.

UNCLASSIFIED

SECRET

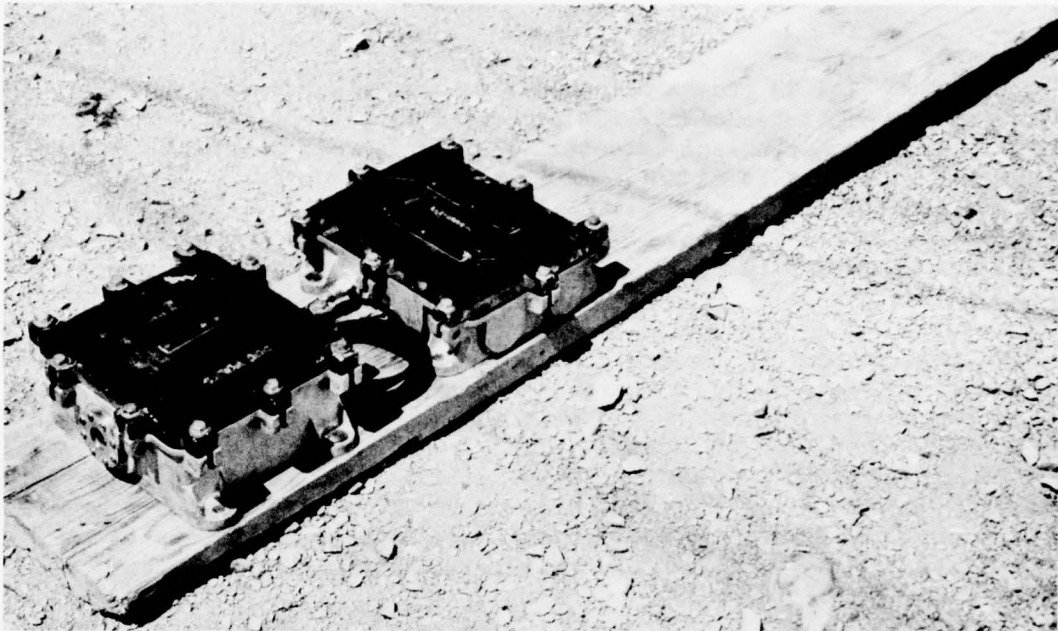

Fig. 4.14 Motion Picture Camera and Battery Box Mounted on Plank



Fig. 4.15 Typical Camera Installation

UNCLASSIFIED

ATOMIC ENERGY ACT 1954

UNCLASSIFIED

Thirty camera placements were made during the course of the operation. In three cases, the cameras failed to operate because of electrical or mechanical defects. In the other 27 placements the cameras performed on signal. Table 4.2 lists each film, where it was used, and its condition. Of the 27 cameras which ran, 11 films (40%) contained useful information. The 16 failures were due to fogging of the film by ionizing radiation.

The films which were exposed for daylight, gave good pictures prior to the bomb detonation, which almost completely obliterated the image. As the bomb light decreased the image gradually returned, but was completely obscured by the dust which accompanied the shock wave. In one of the daylight films the dust cleared quickly enough to catch a picture near the end of its 30 second run. The films which were exposed for bomb light showed nothing until the moment of bomb detonation and then gave pictures with rapidly varying density due to the rapidly changing bomb light intensity. Usable frames were produced until arrival of the dust.

The films contributed valuable information about the exposure equipment in spite of fogging, over and under exposure and dust. Improvements should be directed toward increasing the shielding against gamma rays.

#### 4.3.9 Battery Power Supply

Operation of several of the instruments required a power supply of 24 volts DC moderate current (0.1 ampere) capability. It was convenient to use small dry-batteries for these requirements.

A cast aluminum waterproof junction box identical to that used for the photoelectric relay was employed to house four 7.5 volt "C" dry batteries in series connected to one input and two paralleled output connectors. This allowed operation of two devices from one battery box and one signal source. The battery had nominal open circuit voltage of 30, and a short circuit current of over 2 amperes.

UNCLASSIFIED

UNCLASSIFIED

TABLE 4.2

## Camera Placement and Film Condition

Film No.	Shot No.	Approximate Range (feet)	Type of Station	Approximate r	Result
1	3	1500	Ionizing	1000	Fogged
2	3	2100	Ionizing	1000	Fogged
3	3	2700	Ionizing	650	Satisfactory
4	3	3300	Ionizing	425	Satisfactory
5	3	3700	Thermal	313	Satisfactory
6	3	3700	Thermal	313	Satisfactory
7	3	5300	Thermal	82	Satisfactory
8	3	5300	Thermal	82	Satisfactory
9	4	3500	Ionizing	1445	Fogged
10	3	8000	Thermal	10	Satisfactory
11	4	4000	Ionizing	838	Fogged
12	4	4500	Ionizing	453	Fogged
13	4	3700	Thermal	1200	Fogged
14	4	3700	Thermal	1200	Fogged
15	4	4400	Thermal	520	Satisfactory
16	4	4400	Thermal	520	Satisfactory
17	4	5300	Thermal	168	Satisfactory
18	4	5300	Thermal	168	Satisfactory
19, 20, 21) 23, 24, 25)	5	1100 to 2100	Blast	1000	All fogged
41, 42, 43) 44, 45, 46)	8	1800 to 2600	Blast	1000	All fogged

UNCLASSIFIED

UNCLASSIFIED

~~SECRET~~  
~~CONFIDENTIAL~~

REFERENCES

1. Air Blast Effects of An Atomic Bomb Explosion, Appendix II of Final Report Operation CROSSROADS.
2. Exposure Containers for the Biomedical Program, Annex 2.3, Operation GREENHOUSE.
3. Cornell Aeronautical Laboratory, Inc., Report No. IM-725-P-1 Instruction Manual, Temperature and Pressure Recorders.
4. Dosimetry of X-Rays and Gamma Rays by Radiophotoluminescence by J. H. Schulman, R. J. Ginther and C. C. Klick, NOL Progress Report July 1952.
5. Methods of Statistical Analysis, C. H. Goulden, Chapter XI, John Wiley & Sons, Inc., 1939.

~~SECRET~~

~~CONFIDENTIAL~~

UNCLASSIFIED

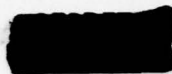

DISTRIBUTION

Copy No.

ARMY ACTIVITIES

Asst. Chief of Staff, G-1, D/A, Washington 25, D. C. ATTN: Human Relations and Research Board	1
Asst. Chief of Staff, G-2, D/A, Washington 25, D. C.	2
Asst. Chief of Staff, G-3, D/A, Washington 25, D. C. ATTN: DACofS, G-3, (RR&SW)	3
Asst. Chief of Staff, G-4, D/A, Washington 25, D. C.	4
Chief of Ordnance, D/A, Washington 25, D. C. ATTN: ORDIX-AR	5
The Surgeon General, D/A, Washington 25, D. C. ATTN: Chairman, Med. Research and Development Board	6- 8
Chief Chemical Officer, D/A, Washington 25, D. C.	9- 10
Chief of Engineers, D/A, Military Construction Division, Protective Construction Branch, Washington 25, D. C. ATTN: ENGEB	11
The Quartermaster General, CBR, Liaison Office, Research and Development Division, D/A, Washington 25, D. C.	12- 13
Office, Chief of Transportation, Military Planning and Intelligence Division, Bldg. T-7, Washington 25, D. C.	14
Chief, Army Field Forces, Ft. Monroe, Va.	15- 18
Army Field Forces Board #1, Ft. Bragg, N. C.	19
Army Field Forces Board #2, Ft. Knox, Ky.	20
Commanding General, First Army, Governor's Island, New York 4, N. Y. ATTN: G-1	21
Commanding General, First Army, Governor's Island, New York 4, N. Y. ATTN: G-2	22
Commanding General, First Army, Governor's Island, New York 4, N. Y. ATTN: G-3	23
Commanding General, First Army, Governor's Island, New York 4, N. Y. ATTN: G-4	24- 25
Commanding General, Second Army, Ft. George G. Meade, Md. ATTN: AIAME	26
Commanding General, Second Army, Ft. George G. Meade, Md. ATTN: AIACM	27
Commanding General, Third Army, Ft. McPherson, Ga. ATTN: ACofS, G-3	28- 29
Commanding General, Fourth Army, Ft. Sam Houston, Tex. ATTN: G-3 Section	30- 31

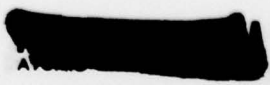
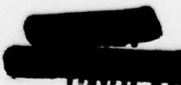

UNCLASSIFIED

DISTRIBUTION (Continued)

Copy No.

Commanding General, Fifth Army, 1660 E. Hyde Park Blvd., Chicago 15, Ill. ATTN: ALFMD-0	32- 35
Commanding General, Sixth Army, Presidio of San Francisco, Calif. ATTN: AMGCT-4	36
Commander-in-Chief, European Command, APO 403, c/o PM, New York, N. Y.	37
Commander-in-Chief, Far East Command, APO 500, c/o PM, San Francisco, Calif. ATTN: ACofS, G-3	38- 42
Commanding General, U. S. Forces Austria, APO 168, c/o PM, New York, N. Y. ATTN: ACofS, G-3	43
Commanding General, U. S. Army Alaska, APO 942, c/o PM, Seattle, Wash.	44
Commanding General, U. S. Army Caribbean, APO 834, c/o PM, New Orleans, La. ATTN: CG, USARCARIB	45
Commanding General, U. S. Army Caribbean, APO 834, c/o PM, New Orleans, La. ATTN: CG, USARFANT	46
Commanding General, U. S. Army Caribbean, APO 834, c/o PM, New Orleans, La. ATTN: Chemical Officer, USARCARIB	47
Commanding General, U. S. Army Caribbean, APO 834, c/o PM, New Orleans, La. ATTN: Surgeon, USARCARIB	48
Commanding General, U. S. Army Pacific, APO 958, c/o PM, San Francisco, Calif. ATTN: Chemical Officer	49- 50
Commanding General, U. S. Army Europe, APO 403, c/o PM, New York, N. Y. ATTN: OPOT Div., Combat Dev. Branch	51- 52
Commanding General, Trieste U. S. Troops, APO 209, c/o PM, New York, N. Y. ATTN: ACofS, G-3	53
Commandant, Command and General Staff College, Ft. Leaven- worth, Kan. ATTN: ALLIS(AS)	54
Commandant, The Infantry School, Ft. Benning, Ga. ATTN: C.D.S.	55- 56
Commandant, The Artillery School, Ft. Sill, Okla.	57
Commandant, The AA&GM Branch, The Artillery School, Ft. Bliss, Tex.	58
Commandant, The Armored School, Ft. Knox, Ky. ATTN: Clas- sified Document Section, Evaluation and Research Division	59- 60
Commanding General, Medical Field Service School, Brooke Army Medical Center, Ft. Sam Houston, Tex.	61
Commandant, Army Medical Service Graduate School, Walter Reed Army Medical Center, Washington 25, D. C. ATTN: Department of Biophysics	62
The Superintendent, U. S. Military Academy, West Point, N. Y. ATTN: Professor of Ordnance	63
Commandant, Chemical Corps School, Chemical Corps Training Command, Ft. McClellan, Ala.	64
Commanding General, Research and Engineering Command, Army Chemical Center, Md. ATTN: Special Projects Officer	65- 66

UNCLASSIFIED

[REDACTED]

UNCLASSIFIED

Security Information

DISTRIBUTION (Continued)

Copy No.

RD Control Officer, Aberdeen Proving Ground, Md. ATTN: Ballistics Research Laboratory	67- 68
Commanding General, The Engineer Center, Ft. Belvoir, Va. ATTN: Asst. Commandant, The Engineer School	69- 71
Commanding General, The Transportation Center and Ft. Eustis, Va. ATTN: Asst. Commandant, Military Sciences and Tactics	72
Chief of Research and Development, D/A, Washington 25, D. C.	73
Commanding Officer, Engineer Research and Development Laboratory, Ft. Belvoir, Va. ATTN: Chief, Technical Intelligence Branch	74
Commanding Officer, Picatinny Arsenal, Dover, N. J. ATTN: ORDBB-TK	75
Commanding Officer, Army Medical Research Laboratory, Ft. Knox, Ky.	76
Commanding Officer, Chemical Corps Chemical and Radio- logical Laboratory, Army Chemical Center, Md. ATTN: Technical Library	77- 78
Director, Technical Documents Center, Evans Signal Laboratory, Belmar, N. J.	79
Commanding Officer, Transportation Research and Develop- ment Station, Ft. Eustis, Va.	80
Director, Operations Research Office, Johns Hopkins Uni- versity, 6410 Connecticut Ave., Chevy Chase, Md. ATTN: Library	81

NAVY ACTIVITIES

Chief of Naval Operations, D/N, Washington 25, D. C. ATTN: OP-36	82- 83
Chief of Naval Operations, D/N, Washington 25, D. C. ATTN: OP-51	84
Chief of Naval Operations, D/N, Washington 25, D. C. ATTN: OP-53	85
Chief, Bureau of Medicine and Surgery, D/N, Washington 25, D. C. ATTN: Special Weapons Defense Division	86- 87
Chief, Bureau of Personnel, D/N, Washington 25, D. C. ATTN: Pers 15	88
Chief, Bureau of Ships, D/N, Washington 25, D. C. ATTN: Code 348	89
Chief, Bureau of Supplies and Accounts, D/N, Washington 25, D. C.	90
Chief, Bureau of Aeronautics, D/N, Washington 25, D. C.	91- 92
Commander-in-Chief, U. S. Atlantic Fleet, Fleet Post Office, New York, N. Y.	93- 94
Commander-in-Chief, U. S. Pacific Fleet, Fleet Post Office, San Francisco, Calif.	95- 96

UNCLASSIFIED



DISTRIBUTION (Continued)

Copy No.

Commandant, U. S. Marine Corps, Headquarters, USMC, Washington 25, D. C. ATTN: Code AO3H	97
President, U. S. Naval War College, Newport, R. I.	98
Superintendent, USN Postgraduate School, Monterey, Calif.	99
Commanding Officer, USN Schools Command, Naval Station, Treasure Island, San Francisco, Calif.	100-101
Director, USMC Development Center, USMC Schools, Quan- tico, Va. ATTN: Marine Corps, Tactics Board	102
Director, USMC Development Center, USMC Schools, Quan- tico, Va. ATTN: Marine Corps, Equipment Board	103
Commanding Officer, Fleet Training Center, Naval Base, Norfolk 11, Va. ATTN: Special Weapons School	104
Commanding Officer, Fleet Training Center (SFWP School), Naval Station, San Diego 36, Calif.	105
Commander, Operational Development Force, U. S. Atlantic Fleet, USN Base, Norfolk 11, Va. ATTN: Tactical Devel- opment Group	106
Commander, Air Force, U. S. Pacific Fleet, Naval Air Sta- tion, San Diego, Calif.	107
Commander, Training Command, U. S. Pacific Fleet, c/o Fleet Sonar School, San Diego 47, Calif.	108
Commanding Officer, Naval Damage Control Training Center, USN Base, Philadelphia 12, Pa. ATTN: ABC Defense Course	109
Commanding Officer, Naval Unit, Chemical Corps School, Ft. McClellan, Ala.	110
Joint Landing Force Board, Marine Barracks, Camp Lejeune, N. C.	111
Commander, USN Ordnance Test Station, Inyokern, China Lake, Calif.	112
Officer-in-Charge, USN Civil Engineering Research and Evaluation Laboratory, Construction Battalion Center, Port Hueneme, Calif. ATTN: Code 753	113-114
Commanding Officer, USN Medical Research Institute, National Naval Medical Center, Bethesda 14, Md.	115
Director, The Materiel Laboratory, New York Naval Ship- yard, New York, N. Y.	116
Commanding Officer and Director, USN Electronics Labo- ratory, San Diego 52, Calif. ATTN: Code 250	117
Commanding Officer and Director, USN Engineering Experi- ment Station, Annapolis, Md. ATTN: Code 155	118
Commanding Officer, USN Radiological Defense Laboratory, San Francisco, Calif. ATTN: Technical Information Division	119-122
Clothing Supply Office, USN Supply Activities, 3d Ave. and 29th St., Brooklyn 32, N. Y. ATTN: Research and Development	123

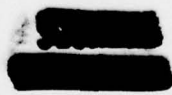
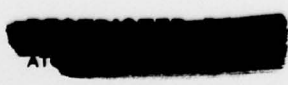

UNCLASSIFIED

UNCLASSIFIED

~~SECRET~~  
~~Security Information~~

UNCLASSIFIED

DISTRIBUTION (Continued)

Copy No.

Commander, Naval Air Development Center, Johnsville, Pa. 124  
Commanding Officer, Office of Naval Research Branch Officer, 1000 Geary St., San Francisco, Calif. 125-126

AIR FORCE ACTIVITIES

Asst. for Atomic Energy, Headquarters, USAF, Washington 25, D. C. ATTN: DCS/O 127  
Asst. for Atomic Energy, Headquarters, USAF, Washington 25, D. C. ATTN: BW&CW Division 128  
Asst. for Development Planning, Headquarters, USAF, Washington 25, D. C. 129-130  
Director of Operations, Headquarters, USAF, Washington 25, D. C. 131-132  
Director of Plans, Headquarters, USAF, Washington 25, D. C. ATTN: War Plans Division 133  
Directorate of Requirements, Headquarters, USAF, Washington 25, D. C. ATTN: AFDRQ-SA/M 134  
Directorate of Research and Development, Armament Division, DCS/D, Headquarters, USAF, Washington 25, D. C. 135  
Directorate of Intelligence, Headquarters, USAF, Washington 25, D. C. 136-137  
The Surgeon General, Headquarters, USAF, Washington 25, D. C. 138-139  
Commanding General, U. S. Air Forces Europe, APO 633, c/o FM, New York, N. Y. 140  
Commanding General, Far East Air Forces, APO 925, c/o FM, San Francisco, Calif. 141  
Commanding General, Alaskan Air Command, APO 942, c/o FM, Seattle, Wash. ATTN: AAOTN 142-146  
Commanding General, Northeast Air Command, APO 862, c/o FM, New York, N. Y. 147  
Commanding General, Strategic Air Command, Offutt AFB, Omaha, Neb. ATTN: Chief, Operations Analysis 148  
Commanding General, Tactical Air Command, Langley AFB, Va. ATTN: Documents Security Branch 149-151  
Commanding General, Air Defense Command, Ent AFB, Colo. 152-153  
Commanding General, Air Materiel Command, Wright-Patterson AFB, Dayton, Ohio 154-156  
Commanding General, Air Training Command, Scott AFB, Belleville, Ill. 157-158  
Commanding General, Air Research and Development Command, PO Box 1395, Baltimore 3, Md. ATTN: RDDN 159-161  
Commanding General, Air Proving Ground Command, Eglin AFB, Fla. ATTN: AG/TRB 162  
Commanding General, Air University, Maxwell AFB, Ala. 163-167  
Commandant, Air Command and Staff School, Maxwell AFB, Ala. 168-169

~~SECRET~~  
UNCLASSIFIED

~~SECRET~~  
DATA

**UNCLASSIFIED**

**UNCLASSIFIED**

DISTRIBUTION (Continued)

Copy No.

Commandant, Air Force School of Aviation Medicine, Randolph AFB, Tex.	170-171
Commanding General, Wright Air Development Center, Wright- Patterson AFB, Dayton, Ohio. ATTN: WCOESP	172-173
Commanding General, AF Cambridge Research Center, 230 Albany St., Cambridge 39, Mass. ATTN: Atomic War- fare Directorate	174
Commanding General, AF Special Weapons Center, Kirtland AFB, N. Mex. ATTN: Chief, Technical Library Branch	175-177
Commandant, USAF Institute of Technology, Wright-Patter- son AFB, Dayton, Ohio. ATTN: Resident College	178
Commanding General, Lowry AFB, Denver, Colo. ATTN: Depart- ment of Armament Training	179-180
Commanding General, 1009th Special Weapons Squadron, 1712 G St., NW, Washington 25, D. C.	181-183
The RAND Corporation, 1500-4th St., Santa Monica, Calif.	184-185

**OTHER DEPTS. OF DEFENSE ACTIVITIES**

Executive Secretary, Joint Chiefs of Staff, Washington 25, D. C. ATTN: Joint Strategic Plans Committee	186
Director, Weapons Systems Evaluation Group, Rm. 2E1006, Pentagon, Washington 25, D. C.	187
Asst. for Civil Defense, OSD, Washington 25, D. C.	188
Chairman, Research and Development Board, D/D, Washing- ton 25, D. C. ATTN: Technical Library	189
Executive Secretary, Committee on Atomic Energy, Research and Development Board, Rm. 3E1075, Pentagon, Washing- ton 25, D. C.	190-191
Executive Secretary, Military Liaison Committee, PO Box 1814, Washington 25, D. C.	192
Commandant, Armed Forces Staff College, Norfolk 11, Va. ATTN: Secretary	193
Commanding General, Field Command, AFSWP, PO Box 5100, Albuquerque, N. Mex.	194-199
Chief, AFSWP, PO Box 2610, Washington 13, D. C.	200-208

**ATOMIC ENERGY COMMISSION ACTIVITIES**

University of California Radiation Laboratory, PO Box 808, Livermore, Calif. ATTN: Margaret Folden	209
Division of Military Application, U. S. Atomic Energy Commission, 1901 Constitution Ave., Washington 25, D. C.	210-212
Los Alamos Scientific Laboratory, Report Library, PO Box 1663, Los Alamos, N. Mex. ATTN: Helen Redman	213-215

**UNCLASSIFIED**

**UNCLASSIFIED**

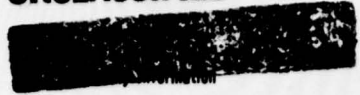

DISTRIBUTION (Continued)

Copy No.

Sandia Corporation, Classified Document Division, Sandia  
Base, Albuquerque, N. Mex. ATTN: Wynne K. Cox  
Weapon Test Reports Group, TIS  
Surplus in TISOR for DMA  
Surplus in TISOR for AFSWP

216-235  
236  
237-286  
287-336

**ADDITIONAL DISTRIBUTION**

Director, Special Weapons Developments, OCAFF, Fort  
Bliss, Texas

337

81



AEC, Oak Ridge, Tenn., A-33274

**UNCLASSIFIED**

D  
80