

AD-A078 593

AIRESEARCH MFG CO OF ARIZONA PHOENIX  
HOT ISOSTATIC PRESSING REJUVENATION OF DISKS.(U)  
JUL 79 D V SUNDBERG , D H COMEY

F/G 13/8

UNCLASSIFIED

21-3238

AFML-TR-79-4093

F33615-77-C-5113

NL

1 OF 2

AD  
A 078593



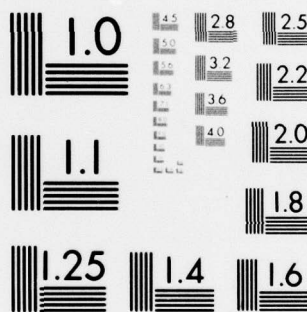

MICROCOPY RESOLUTION TEST CHART  
NATIONAL BUREAU OF STANDARDS-1963-A

ADA 078593

ML-TR-79-4093

**LEVEL II**

2 SC

21-3238

HOT ISOSTATIC PRESSING REJUVENATION OF DISKS

DDC  
RECEIVED  
DEC 27 1979  
E

AiResearch Manufacturing Company of Arizona  
111 South 34th Street  
Phoenix, Arizona 85010

July 1979

TECHNICAL REPORT AFML-TR-79-4093

Final Report for Period 1 September 1977 to 31 May 1979

Approved for public release; distribution unlimited.

DDC  
FILE COPY

AIR FORCE MATERIALS LABORATORY  
AIR FORCE WRIGHT AERONAUTICAL LABORATORIES  
AIR FORCE SYSTEMS COMMAND  
WRIGHT-PATTERSON AIR FORCE BASE, OHIO 45433

79 12 19 203

NOTICE

When Government drawings, specifications, or other data are used for any purpose other than in connection with a definitely related Government procurement operation, the United States Government thereby incurs no responsibility nor any obligation whatsoever; and the fact that the government may have formulated, furnished, or in any way supplied the said drawings, specifications, or other data, is not to be regarded by implication or otherwise as in any manner licensing the holder or any other person or corporation, or conveying any rights or permission to manufacture, use, or sell any patented invention that may in any way be related thereto.

This report has been reviewed by the Information Office (OI) and is releasable to the National Technical Information Service (NTIS). At NTIS it will be available to the general public, including foreign nations.

This technical report has been reviewed and is approved for publication.

*Attwell M. Adair*

ATTWELL M. ADAIR  
Project Engineer

FOR THE COMMANDER

*Henry C. Graham*

HENRY C. GRAHAM  
CHIEF

Processing and High Temperature Materials Branch  
Metals and Ceramics Division

If your address has changed, if you wish to be removed from our mailing list, or if the addressee is no longer employed by your organization please notify AFML/LLM WPAFB OH 45433 to help us maintain a current mailing list.

Copies of this report should not be returned unless return is required by security considerations, contractual obligations, or notice on a specific document.

Unclassified

SECURITY CLASSIFICATION OF THIS PAGE (When Data Entered)

REPORT DOCUMENTATION PAGE		READ INSTRUCTIONS BEFORE COMPLETING FORM
1. REPORT NUMBER AFML-TR-79-4093	2. GOVT ACCESSION NO.	3. RECIPIENT'S CATALOG NUMBER
4. TITLE (and Subtitle) Hot Isostatic Pressing Rejuvenation of Disks.	5. TYPE OF REPORT & PERIOD COVERED Final Technical Report 1 Sept. 1977-31 May 1979	6. PERFORMING ORG. REPORT NUMBER 21-3238
7. AUTHOR(s) D. V. Sundberg H. H. Comey	8. CONTRACT OR GRANT NUMBER(s) F33615-77-C-5113	
9. PERFORMING ORGANIZATION NAME AND ADDRESS AiResearch Manufacturing Co. of Arizona/ 111 South 34th Street Phoenix, Arizona 85034	10. PROGRAM ELEMENT, PROJECT, TASK AREA & WORK UNIT NUMBERS 62102F 24200106	
11. CONTROLLING OFFICE NAME AND ADDRESS Air Force Materials Laboratory Air Force Systems Command USAF Wright-Patterson AFB, Ohio 45433	12. REPORT DATE 11 July 1979	13. NUMBER OF PAGES
14. MONITORING AGENCY NAME & ADDRESS (if different from Controlling Office)	15. SECURITY CLASS. (of this report) Unclassified	15a. DECLASSIFICATION/DOWNGRADING SCHEDULE
16. DISTRIBUTION STATEMENT (of this report) <i>This document has been approved for public release and sale; its distribution is unlimited.</i>		
17. DISTRIBUTION STATEMENT (of the abstract entered in Block 20, if different from Report) Approved for public release; distribution unlimited.		
18. SUPPLEMENTARY NOTES		
19. KEY WORDS (Continue on reverse side if necessary and identify by block number) Waspaloy Disk, Ti-6Al-4V Disk, Hot Isostatic Pressing, Repair-Salvage, Life-Extension		
20. ABSTRACT (Continue on reverse side if necessary and identify by block number) Retired field-service Ti-6Al-4V compressor disks and Waspaloy turbine disks from Garrett-AiResearch auxiliary power units were secured for the program test material. They were given a thorough dimensional inspection, nondestructive evaluation (NDE) and metallurgical characterization including mechanical properties and evaluation of microstructures. Baseline low-cycle-fatigue (LCF) lives for these disks were determined by cyclic-spin testing and periodic inspection of new disks.		

DD FORM 1 JAN 73 1473 EDITION OF 1 NOV 65 IS OBSOLETE

Unclassified

SECURITY CLASSIFICATION OF THIS PAGE (When Data Entered)

404 796

Unclassified

SECURITY CLASSIFICATION OF THIS PAGE(When Data Entered)

Cleaning and crack bridging techniques were evaluated on the disk materials and reverse-sputter cleaning combined with ion plating was chosen for the preparation of cracked disks prior to hot isostatic pressing (HIP). The HIP parameters were selected for each alloy and the disks were fixtured, protected from excessive oxidation, and HIPped using pressurized argon gas. The Ti-6Al-4V compressor disks were evaluated in the HIPped condition, while the Waspaloy disks were given a post-HIP heat treatment.

The post-HIP evaluation included NDE, dimensional inspection, mechanical property determinations and microstructure determination. The results showed that the disks were out of blueprint tolerances and the NDE techniques selected were not effective in determining whether or not cracks were healed. The mechanical properties and metallurgical characteristics of the materials after HIP were equivalent to those determined prior to HIP with the exception of blade attachment dovetail or firtree LCF. While metallographic evidence indicated healing of service induced cracks, spin-testing to evaluate attachment LCF life disclosed approximately a 50-percent reduction in life for the Ti-6Al-4V disks compared to the baseline. The service-cracked Waspaloy disks were not rejuvenated (cracks did not bond); however, an uncracked, HIPped Waspaloy disk did show fatigue life equivalent to the new disk baseline, indicating that HIP rejuvenation of uncracked Waspaloy disks was successful.

The exploratory development program provided a number of facts related to rejuvenation of field-service hardware. The ion plate bridging technique utilized on the Ti-6Al-4V compressor disks was successful. However, a beta stabilized layer was produced on the disk surface. The elimination of the beta layer requires further investigation of alternate plating materials. The LCF life reduction after HIP also requires further investigation. The rejuvenation of an uncracked Waspaloy turbine disk was demonstrated. Additional work is required on cleaning of cracks and even with clean cracks diffusion bonding of Waspaloy may not occur. Fixturing of disks to maintain dimensions and improved NDE techniques are also required for a successful rejuvenation process.

Unclassified

SECURITY CLASSIFICATION OF THIS PAGE(When Data Entered)

PREFACE

This final technology report, submitted by AiResearch Manufacturing Company of Arizona, a division of The Garrett Corporation, documents the activities completed during the Hot Isostatic Pressing Rejuvenation of Disks Program conducted under Contract F33615-77-C-5113. This effort, covering the period from September 1977 to May 1979, was sponsored by the Air Force Materials Laboratory, Wright Patterson Air Force Base, Ohio, with Mr. A. M. Adair (AFML/LLM) as Project Engineer. The program was directed by Mr. Donal H. Comey, Propulsion Advanced Technology, and the principal investigator was Mr. David V. Sundberg, Advanced Materials and Processing. Technical Support was provided by Miss Patricia Thompson, Propulsion Advanced Technology, George Hoppin, III, Advanced Materials and Processing, Mr. Tom Peters, Test Laboratory, and Mr. William Spaulding, Quality Assurance. Metallurgical consultation and Transmission Electron Microscopy was performed by Dr. J. C. Williams of Carnegie-Mellon University, Pittsburgh.

Accession For	
NTIS GRA&I	<input checked="" type="checkbox"/>
DDC TAB	<input type="checkbox"/>
Unannounced	<input type="checkbox"/>
Justification	
By _____	
Distribution/_____	
Availability Codes	
Dist	Avail and/or special
A	

## TABLE OF CONTENTS

	<u>Page</u>
PREFACE	i
1.0 INTRODUCTION	1
2.0 TECHNICAL DISCUSSION	4
2.1 Task I - Disk Examination and Characterization	4
2.1.1 Secure Disks	4
2.1.1.1 Ti-6Al-4V Compressor Disks	4
2.1.1.2 Waspaloy Turbine Disks	8
2.1.2 Nondestructive Evaluation (NDE)	12
2.1.2.1 Ti-6Al-4V Compressor Disks	15
2.1.2.2 Waspaloy Turbine Disks	16
2.1.3 Dimensional Measurements	19
2.1.4 Metallurgical Evaluation	23
2.1.4.1 Ti-6Al-4V Compressor Disks	23
2.1.4.2 Waspaloy Turbine Disks	29
2.1.5 Cyclic-Spin Testing	36
2.1.5.1 Ti-6Al-4V Compressor Disks	36
2.1.5.2 Waspaloy Turbine Disks	40
2.2 Task II - Preparation for Hot Isostatic Pressing (HIP)	51
2.2.1 Cleaning Techniques	51
2.2.2 Bridging Techniques	52
2.2.2.1 Test Samples	53
2.2.2.2 Field-Service Disks	58
2.3 Task III - Hot Isostatic Pressing (HIP)	61
2.3.1 Ti-6Al-4V Compressor Disks	61
2.3.1.1 Ti-6Al-4V Compressor Disk Heat Treatment	62
2.3.2 Waspaloy Turbine Disks	69
2.3.2.1 Waspaloy Turbine Disk Heat Treatment	77
2.4 Task IV - Post-HIP Examination	80
2.4.1 Nondestructive Evaluation	80
2.4.1.1 Ti-6Al-4V Compressor Disks	80
2.4.1.2 Waspaloy Turbine Disks	82

TABLE OF CONTENTS (CONTD)

	<u>Page</u>
2.4.2 Dimensional Inspection	82
2.4.3 Metallurgical Evaluation	83
2.4.3.1 Ti-6Al-4V Compressor Disks	85
2.4.3.2 Waspaloy Turbine Disks	94
2.4.4 Whirlpit Testing	102
2.4.4.1 Ti-6Al-4V Compressor Disks	102
2.4.4.2 Waspaloy Turbine Disks	114
2.5 Environmental Consequences	117
3.0 CONCLUSIONS AND RECOMMENDATIONS	122
3.1 Ti-6Al-4V Compressor Disks	122
3.2 Waspaloy Turbine Disks	123

## LIST OF ILLUSTRATIONS

<u>Figure</u>	<u>Title</u>	<u>Page</u>
1	Program Progress Schedule	3
2	Retired First-Stage Compressor Disk from an AiResearch Model TSCP700 APU. Arrows Show Typical Locations of Fatigue Cracks	5
3	Cross Section of TSCP700 Engine Showing Location of Compressor and Turbine Disks Utilized in the HIP Program	6
4	Cross Section of GTCP660 Engine Showing Location of the Turbine Disks Utilized in the HIP Program	9
5	Retired Second-Stage Turbine Disk from an AiResearch Model GTCP660 APU	10
6	TSCP700 High-Pressure Turbine Disk	13
7	Eddy-Current Probe in TSCP700 Compressor Disk	17
8	Ti-6Al-4V Compressor Disk Showing a Relatively Large Crack Which Has Propagated to the Surface (Left, Arrow) and the Result of Prolonged Cycling with a Crack Evident (Right) on the Surface	18
9	Location of Dimensional Measurements Taken On Field-Service Compressor Disks	22
10	Location of Dimensional Measurements Taken on Field-Service Turbine Disks	25
11	Metallurgical Sample Locations from Field-Service Returned Ti-6Al-4V Alloy Compressor Disks	26
12	Low-Cycle-Fatigue Results for Ti 6Al-4V Compressor Disk Test Specimens	30
13	Typical Microstructure of Ti-6Al-4V Compressor Disks Returned from the Field	31
14	TEM Examination of Field-Service Compressor Disks in the Region of the Dovetails	32
15	Metallurgical Sample Locations from Waspaloy Turbine Disks	33

LIST OF ILLUSTRATIONS (CONTD)

<u>Figure</u>	<u>Title</u>	<u>Page</u>
16	Low-Cycle-Fatigue Results for Field-Service Waspaloy Turbine Disk Test Specimens	37
17	Typical Microstructure of a Waspaloy Turbine Disk	38
18	TEM Examination of Field-Service Turbine Disks in the Region of the Firtrees	39
19	Whirlpit Setup for Spin Testing Ti-6Al-4V TSCP700 Compressor Disk	41
20	Spin-Test Setup for GTCP660 Engine Waspaloy Turbine Disk	45
21	Spin-Test Setup for Spin Testing of Waspaloy TSCP700 Turbine Disks	47
22	Low-Cycle-Fatigue Crack Produced in 6070 Cycles by Cyclic Spin Testing at Room Temperature, Disk Serial No. 1799	49
23	Low-Cycle-Fatigue Cracks Detected in Field-Service Disk Serial No. 90149A.	50
24	Dovetail Crack in a Ti-6Al-4V Alloy Compressor Disk Test Sample Bridged by Ion Plating with Pure Titanium (A) and Pure Copper (B)	54
25	Dovetail Crack in a Ti-6Al-4V Alloy Compressor Disk Test Sample Bridged by Vacuum Plasma Spraying Pure Titanium (A), Pure Copper (B), and Followed by a Layer of Nickel (C) and a Layer of Copper (D) to Aid in Metallographic Sample Preparation	55
26	Cracks in Waspaloy Stress-Rupture Bar Cleaned and Bridged by Ion Plating Techniques. Ion-Plated Pure Nickel (A), Followed by a Flash of Copper (B), and Electroless Nickel (C). (B) and (C) Used as Sample Preparation Aids	56
27	Surface of Waspaloy Stress-Rupture Test Bar Before (Left) and After Grit Blasting, Transferred Arc Cleaning and Vacuum Plasma Spraying of Nickel A (Right). Copper B and Nickel C are for Metallographic Sample Preparation	57

LIST OF ILLUSTRATIONS (CONTD)

<u>Figure</u>	<u>Title</u>	<u>Page</u>
28	Five TSCP700 Compressor Disks Which Have Been Reverse-Sputter Cleaned and Ion Plated with Pure Titanium Followed by a Flash of Copper. MAG: 0.3X	59
29	Turbine Disks and Disk Sections Ion Plated with Pure Nickel Prior to HIP	60
30	Effect on Microstructure of Ti-6Al-4V of Four-Hour Exposure at Temperatures Indicated. Etchant: HF-HNO <sub>3</sub> MAG: 200X	63
31	Effect on Microstructure of Ti-6Al-4V, Four-Hour Exposure at Temperatures Indicated. Etchant: HF-HNO <sub>3</sub> Mag: 500X	64
32	Loading Arrangement of Compressor Disk in HIP Autoclave Showing Rig Support Tooling	66
33	Ti-6Al-4V Alloy Compressor Disks (and Sections) After HIP	67
34	Test Specimen/Tooling Arrangement	71
35	View Inside Chamber Showing Induction Coil and Susceptors. Top Tooling Removed	72
36	Photomicrographs Showing Grain Growth Experienced by 1900°F/4-hr/5-ksi Bond Specimen (After Heat Treatment)	75
37	SEM Photomicrographs of Typical Bond Joint Showing Aluminum/Titanium Oxide Interlayer. Note Recrystallization Adjacent to Bond	76
38	As-HIPped Waspaloy Disks and Disk Sections	78
39	Ti-6Al-4V Alloy Compressor Disk After HIP and Copper Plate Removal. Note corrosion (arrows)	81
40	Microstructure of HIP Rejuvenated Ti-6Al-4V Compressor Disk Dovetail Corner	86
41	Electron Microprobe Chemical Analysis Results of Stabilized Beta Phase Layer in Ti-6Al-4V	87
42	Surfaces of Disk S/N 1706 at the OD and at the Base of the Dovetail	88

LIST OF ILLUSTRATIONS (CONTD)

<u>Figure</u>	<u>Title</u>	<u>Page</u>
43	SEM Photomicrographs of OD Dovetail Corner Showing Stabilized Beta on the Side and the Absence of the Beta Layer on the OD (Arrows Indicate Positons of X-Ray Analyses)	89
44	Cracks in Ti-6Al-4V Alloy Compressor Disk	89
45	Surface of Unbridged and HIPped Ti-6Al-4V Compressor Disk S/N 4774	92
46	UnHIPped Versus HIPped Load Controlled LCF Curves of Ti-6Al-4V Disk at Room Temperature	95
47	TEM Photographs of Dislocation in Ti-6Al-4V Compressor Disks after HIP. Dislocation Densities are Approximately $10^7$ to $10^8$ Per Square Centimeter	96
48	Pre- and Post-HIP Microstructures of Waspaloy Disk Serial No. 1351. Etchant: Kallings	97
49	Base of Firtree in Waspaloy Turbine Disk after HIP and Heat Treatment. Cracks are bridged with Pure Nickel (Layer 1) which Formed a Bridge to Seal them During HIP	98
50	UnHIPped Versus HIPped Load Controlled LCF Properties of Waspaloy Turbine Disks at 1000°F	101
51	TEM Examinations of Waspaloy After HIP. The Dislocation Density is Estimated to be $10^6$ Per Square Centimeter (Mag: 2700X)	103
52	Ti-6Al-4V Alloy Compressor Disk S/N 717 Failure After 1410 Cycles in the Cyclic Spin Pit	105
53	Crack Extending from the Dovetail on the Face of HIPped Compressor Disk S/N 4843. (Arrows Show Crack)	107
54	Location of LCF Crack and SEM Image of Fatigue Striations. Disk S/N 4873 (New Disk Baseline)	110
55	SEM Analysis of Dovetail Surface Before and After HIP	112

LIST OF ILLUSTRATIONS (CONTD)

<u>Figure</u>	<u>Title</u>	<u>Page</u>
56	Cross Section of the Bases of Two Firtrees After Bridging with Nickel, HIP, Heat Treatment and Spin Testing. Etchant: Modified Kallings. Mag.: 100X. Arrows Indicate Nickel Bridge	116
57	Appearance of Fatigue Cracks at the Base of Firtrees in Field-Service Disk Serial No. 90149A and in Cyclic-Spin Tested HIPped Disk Serial No. 2909.	119
58	Appearance in the SEM, of Waspaloy Before and After HIP.	120

LIST OF TABLES

<u>Table</u>	<u>Title</u>	<u>Page</u>
1	Retired Compressor Disk Inspection and History	7
2	Retired GTCP660 Turbine Disk History and Inspection Results	11
3	Retired TSCP700 Turbine Disk History and Inspection Results	14
4	Eddy-Current Inspection Results of Field-Service Returned Waspaloy Turbine Disks for the GTCP660 Engine	20
5	Dimensions Measured on TSCP700 Compressor Disks Prior to HIP and Heat Treatment	21
6	Dimensions Measured on GTCP660 Turbine Disks Prior to HIP and Heat Treatment	24
7	Sample Identification for Field-Service Returned Compressor Disks	27
8	Ti-6Al-4V Tensile Properties at Room Temperature - Before HIP	28
9	Sample Identification for Field-Service Turbine Disks	34
10	Waspaloy Tensile Properties at 1000°F Generated from Field-Service Disks	35
11	Summary of New Ti-6Al-4V TSCP700 APU First-Stage compressor Disk Cyclic-Spin Testing	42
12	Summary of Field-Service Ti-6Al-4V TSCP700 APU First-Stage Compressor Disk Cyclic-Spin Testing	43
13	TSCP700 APU High-Pressure Turbine Disk Cyclic Spin Test Results	42
14	Purity of Argon Gas Used for HIP of Ti-6Al-4V Turbine Disks	65
15	As-HIPPed Room-Temperature Tensile Properties from Ti-6Al-4V Alloy Disk	68

LIST OF TABLES (CONTD)

<u>Table</u>	<u>Title</u>	<u>Page</u>
16	Waspaloy Surface Preparation	70
17	Bonding Parameters and Tensile Data for Waspaloy Cylinders.	74
18	Purity of Argon Gas Used for HIP of Waspaloy Turbine Disks.	79
19	Post-HIP Dimensional Analysis on Waspaloy Turbine Disks	84
20	Electron Microprobe Chemical Analysis Results of Stabilized Beta Phase Layer in Ti-6Al-4V	93
21	Comparison of Pre-HIP and Post-HIP Room-Temperature Tensile Properties of the Ti-6Al-4V Alloy Compressor Disks	100
22	Comparison of Pre-HIP and Post-HIP 1000°F. Tensile Properties of Waspaloy Turbine Disks	108
23	Summary of Ti-6Al-4V Compressor Disk Cyclic-Spin Testing After HIP Compared to New Disk Baseline	113
24	Auger Spectroscopy Chemical Analysis at a Depth of 0.000012 Inch Below the Surface. All Samples From Disk Serial No. 4774	113
25	Residual Gas Analyses of Samples Taken From Disk Serial No. 4774 Before and After HIP	118

## 1.0 INTRODUCTION

High thrust-to-weight ratios have been attained in advanced military aircraft engines by using highly stressed rotating parts of high-strength nickel- and titanium-base alloys. The life of disks made of these alloys is determined by low-cycle-fatigue (LCF) limits, to prevent catastrophic failures. Disks are retired because they have reached their LCF cyclic life limits, whether or not they exhibit cracks. Retirement of these disks increases engine ownership costs by requiring that they be replaced with new parts. If the retired parts could be rejuvenated and reused, significant cost savings would be realized. A completely analogous situation exists with the high-performance auxiliary power unit (APU) gas turbines employed in modern commercial aircraft. Similar part geometries and often identical materials are utilized in the APUs as in the large propulsion engines.

Rejuvenation through the use of Hot Isostatic Pressing (HIP) has been investigated. Battelle has performed AFML-sponsored programs on Ti-6Al-4V<sup>1</sup> and on IN-718<sup>2</sup> alloys utilizing test specimens to determine benefits from HIP. AiResearch<sup>3</sup> has shown evidence of healing internally initiated low-cycle-fatigue damage in a large radial turbine wheel by HIP. Others are investigating rejuvenation by thermal treatments.

In this program, the process of Hot Isostatic Pressing (HIP) was investigated as a means of rejuvenating retired field-service nickel-base and titanium-alloy engine disks. Waspaloy turbine disks and titanium compressor disks were cleaned, plated with appropriate materials, and HIPped. The disks were cyclic tested before and after HIPping to determine the extent of rejuvenation. The program consisted of five tasks:

- o Task I - Disk Examination/Characterization
- o Task II - Preparation for HIP
- o Task III - Hot Isostatic Pressing
- o Task IV - Post-HIP Examination
- o Task V - Final Processing Selection

In Task I, Waspaloy nickel-alloy turbine disks and Ti-6Al-4V titanium-alloy compressor disks were obtained from high-time auxiliary power units (APUs) in commercial airline service. These parts were exhaustively characterized using standard metallographic and nondestructive evaluation techniques to determine their pre-HIP properties. The disks were prepared for HIP in Task II by cleaning and bridging with appropriate materials to seal service-induced cracks. In Task III, the compressor and turbine disks were HIPped separately at temperatures, pressures, and times selected to minimize the chances of material property degradation. The disks were supported on special tooling to minimize dimensional distortion. Where necessary, a post-HIP heat treatment was performed on the disks to restore mechanical properties. After HIP, the disks were again characterized extensively in Task IV. Testing included whirlpit cycling to determine the useful life after the HIP process. In the final task, all of the data gathered in the first four tasks was evaluated and conclusions and recommendations were formulated. A summary briefing was presented to interested AFML personnel on April 24, 1979.

The tasks followed the program schedule shown in Figure 1. The following sections describe in detail the tasks of the program.

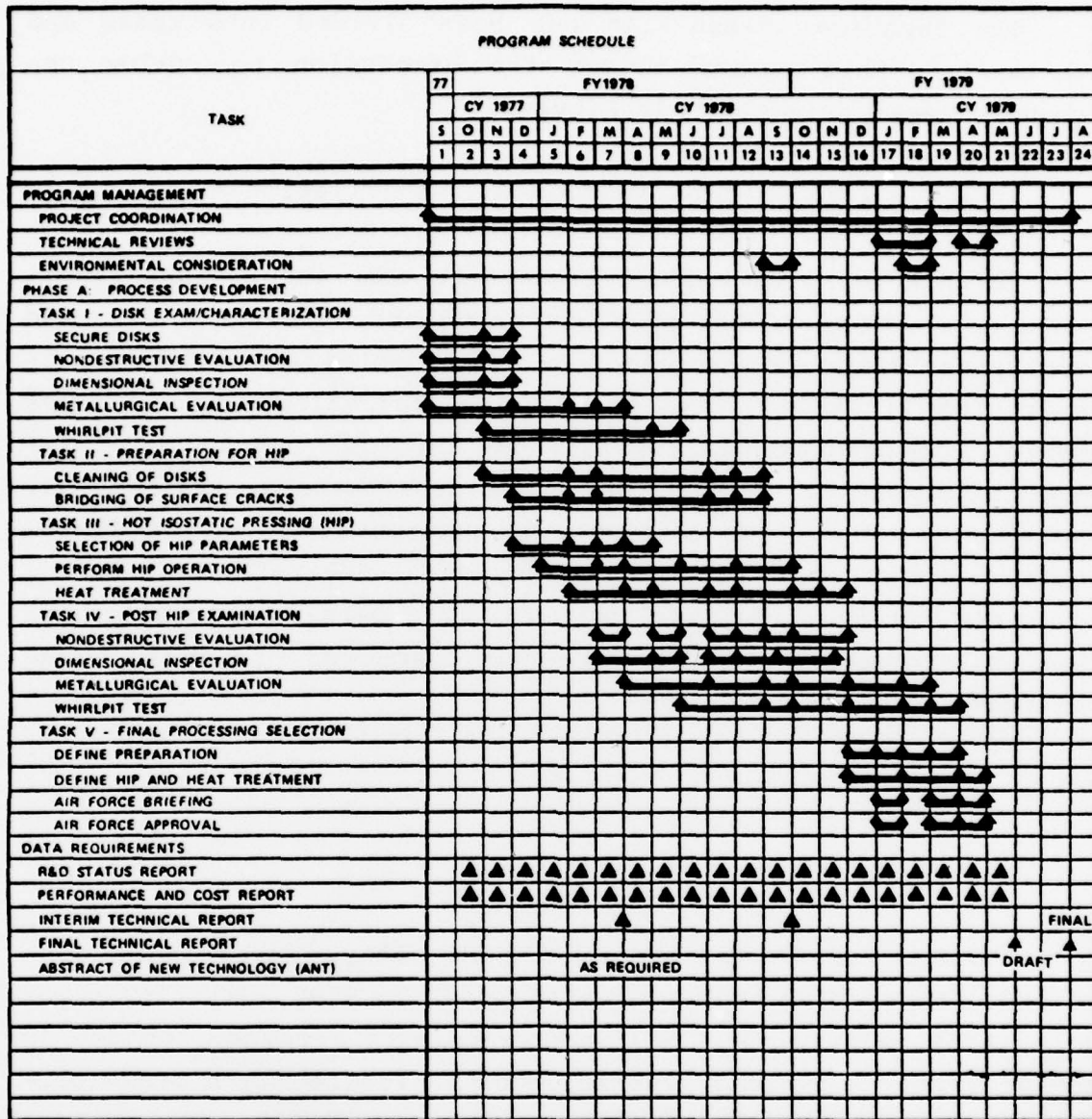

Figure 1. Program Progress Schedule.

## 2.0 TECHNICAL DISCUSSION

The technical discussion has been divided into tasks and sub-tasks. This format allows the discussion to follow the schedule previously shown in Figure 1.

### 2.1 Task I - Disk Examination and Characterization

In this task, retired field-service compressor disks fabricated from forged Ti-6Al-4V alloy, and turbine disks fabricated from forged Waspaloy were secured and characterized. The characterization included nondestructive evaluation for fatigue cracks, dimensional measurements in critical areas, determination of mechanical properties, and microstructural evaluations. In addition, new disks of the same configuration as the field-service disks were procured so that a dovetail or firtree low-cycle-fatigue life baseline could be generated by cyclic-spin testing. Progress on each sub-task is discussed in the following sections.

#### 2.1.1 Secure Disks

##### 2.1.1.1 Ti-6Al-4V Compressor Disks

A total of 24 retired Ti-6Al-4V alloy, first-stage compressor disks, from the AiResearch Model TSCP700 auxiliary power unit (APU) used in the DC-10 aircraft, were obtained for use in the program. A typical disk is shown in Figure 2. A cross section of the TSCP700 engine with an arrow identifying the subject disk is shown in Figure 3. All the disks were retired because of cracks in the dovetail (blade attachment) slots. The approximate number of service cycles for each retired disk along with approximate crack depth is shown in Table 1. The crack depths were

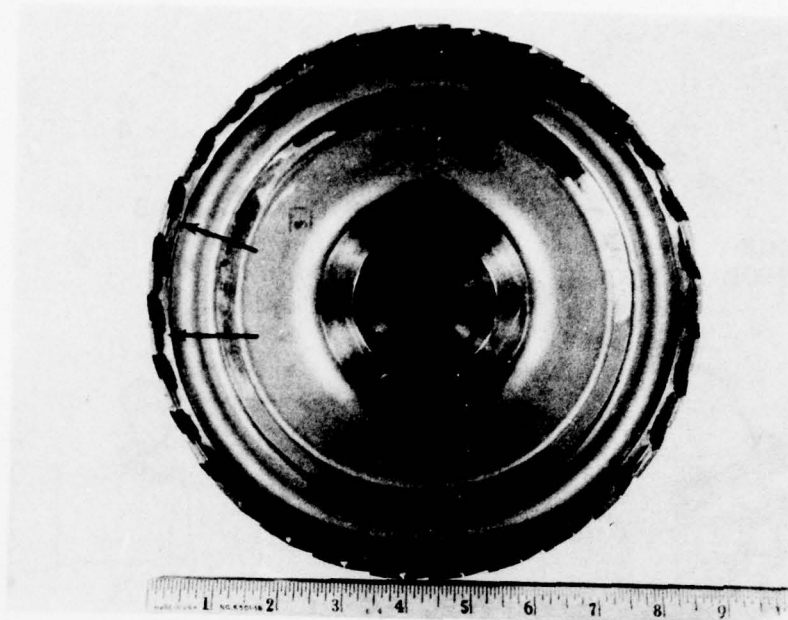

FORWARD SIDE

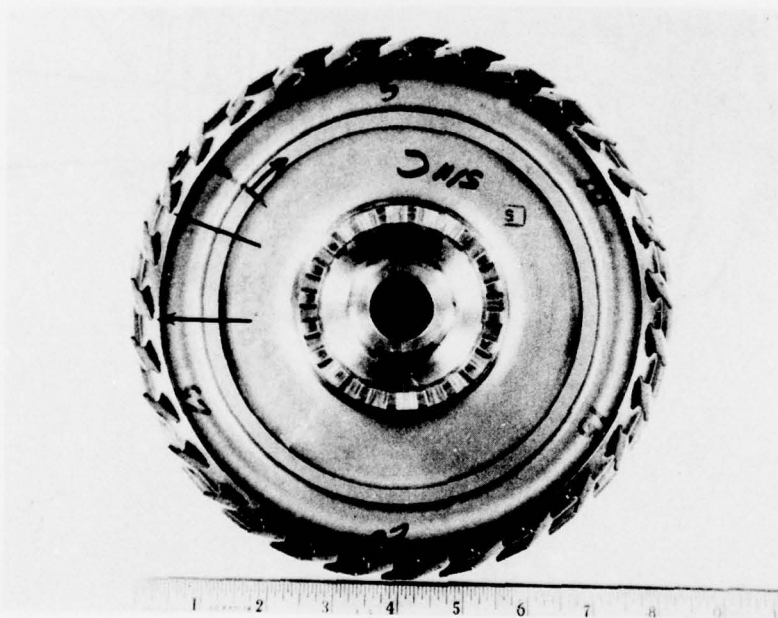

AFT SIDE

Figure 2. Retired First-Stage Compressor Disk from an AiResearch Model TSCP700 APU. Arrows Show Typical Locations of Fatigue Cracks.

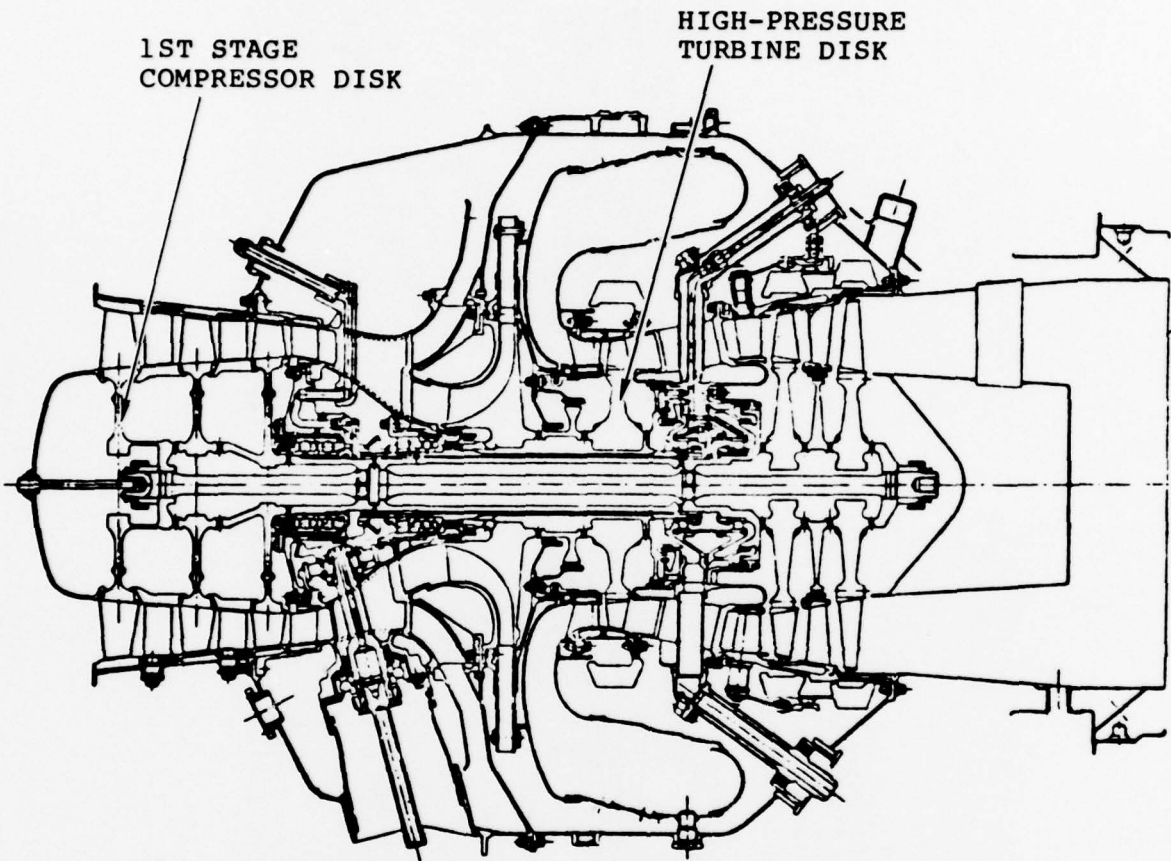

Figure 3. Cross Section of TSCP700 Engine Showing Location of Compressor and Turbine Disks Utilized in the HIP Program.

TABLE 1. RETIRED COMPRESSOR DISK INSPECTION AND HISTORY

Disk S/N	Approximate Number of Field-Cycles	Could Not Measure	Indicated Number of Cracks By Size Group (Inches) - Eddy-Current Method		
			0.000- 0.009	0.012- 0.018	0.021- Over
0-18040-1706	N/A*	0	57	0	1
-1728	1115	0	55	2	1
-1738	4975	3	46	9	0
1-18040-0799	2133	2	52	4	0
-1347	1550	0	56	2	0
-1356	N/A	1	7	12	38
-1427	N/A	0	58	0	0
-2551	N/A	0	56	2	0
-2561	4240	0	56	2	0
2-18040-0324	N/A	0	56	2	0
4-03501-0717	N/A	0	56	2	0
-4731	N/A	0	57	1	0
-4740	N/A	0	58	0	0
-4774	N/A	0	45	12	1
-4778	3574	0	58	0	0
-4802	N/A	0	57	1	0
-4804	N/A	0	57	1	0
-4829	N/A	0	53	5	0
-4831	N/A	2	50	6	0
-4843	N/A	0	57	1	0
-4845	N/A	0	55	3	0
7-03501-1883	N/A	0	58	0	0
-2606	N/A	0	58	0	0
-2718	N/A	0	57	1	0

\*Not available

determined using an eddy-current technique described in Section 2.1.2. In addition to the retired titanium disks, three new disks of the same configuration were obtained for the purpose of generating baseline low-cycle-fatigue data on the initiation and progression of dovetail cracks.

#### 2.1.1.2 Waspaloy Turbine Disks

The Waspaloy turbine disks originally secured for the program were first-stage and second-stage disks from the AiResearch Model GTCP660 APU used in the Boeing 747 aircraft. A cross section of the engine is shown in Figure 4 with the location of the turbine disks indicated. As will be discussed in Section 2.1.5, cracks were not found in these field-service turbine disks, and could not be generated by cyclic-spin testing. This resulted in a program redirection to secure Waspaloy high-pressure turbine disks from the TSCP700 APU, which did exhibit firtree low-cycle-fatigue (LCF) cracks in the field (refer to Figure 3 for location of disk). The GTCP660 disks were still utilized for metallurgical and dimensional evaluation before and after HIPping.

A total of eleven retired GTCP660 Waspaloy turbine disks were secured. Four of these were first-stage disks, and the remaining seven were second-stage disks. Figure 5 shows a typical second-stage disk. The two disks are similar in configuration and firtree detail; the only difference being a larger outside diameter on the first-stage disk. These disks were retired after approximately 15,000 hours of service. Table 2 gives the available documented data obtained on the retired disks. In addition to the retired disks, three new second-stage disks of the same configuration were obtained for the purpose of generating baseline low-cycle-fatigue data.

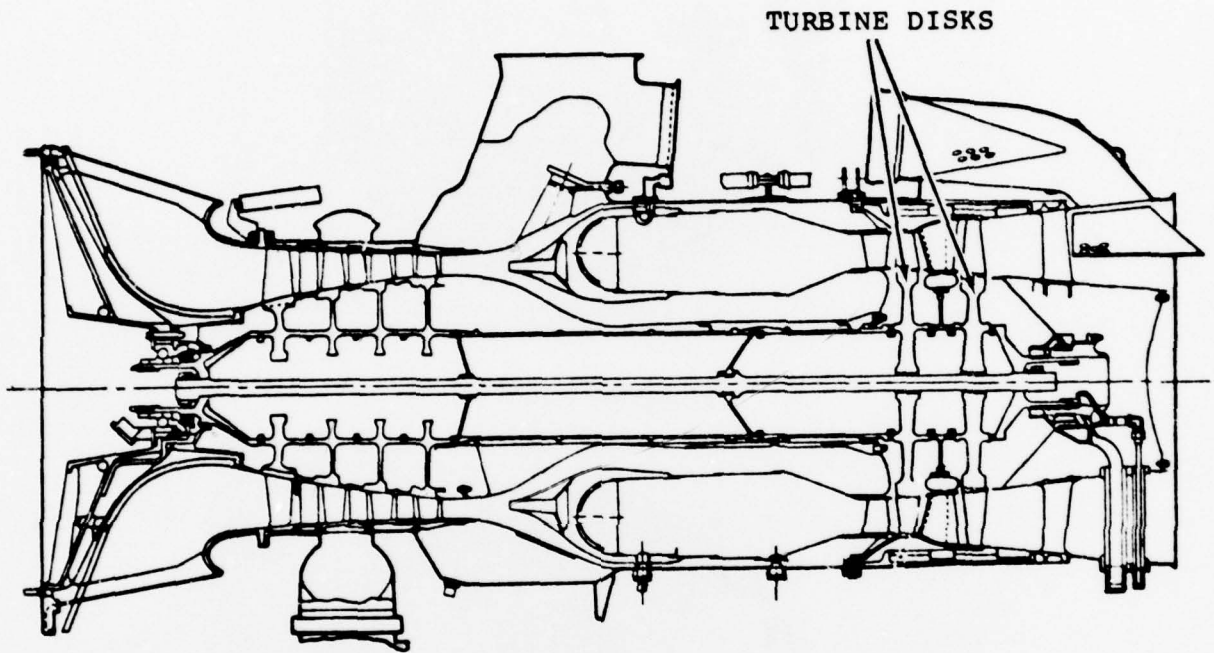
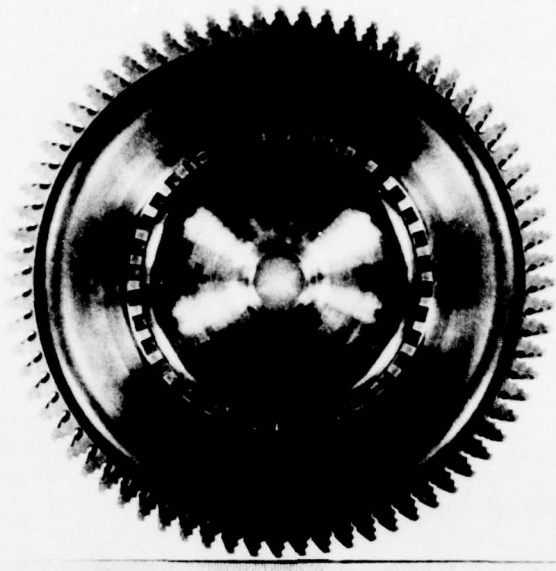
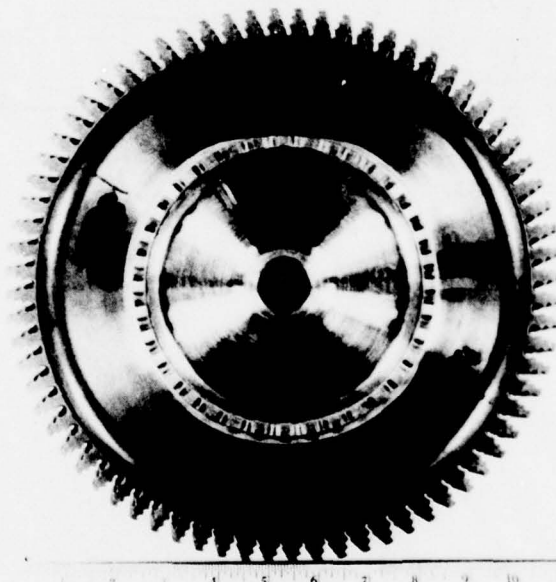

Figure 4. Cross Section of GTCP660 Engine Showing Location of the Turbine Disks Utilized in the HIP Program.



FORWARD SIDE



AFT SIDE

Figure 5. Retired Second-Stage Turbine Disk from an AiResearch Model GTCP660 APU.

TABLE 2. RETIRED GTC660 TURBINE DISK HISTORY AND INSPECTION RESULTS

Stage	Disk Serial No.	Reported Number of Service Hours	Number of Cracked Firtrees
First	1-18040-1351	13,587	None
	0-18040-255	14,035	None
	0-18040-320	13,601	None
	1-18040-2425	~15,000	None
Second	8-18040-813	~15,000	None
	0-18040-1140	15,064	None
	0-18040-1187	14,345	None
	0-18040-1190	~15,000	None
	0-18040-1316	~15,000	None
	8-18040-2370	13,601	None
	8-18040-2391	15,165	None

Four TSCP700 high-pressure turbine disks (Part Number 977156) were obtained from commercial airlines. Three of these disks exhibited LCF cracking in the firtrees. The fourth disk (Figure 6) was found to be crack free. Table 3 documents the disk service time and the results of the fluorescent-penetrant and visual inspections which detected the firtree cracks.

#### 2.1.2 Nondestructive Evaluation (NDE)

Four NDE techniques were originally proposed as candidates for detecting fatigue damage in the retired field-service disks. They were: (1) radiography and image enhancement; (2) ultrasonics, (3) sensitive fluorescent penetrants; and (4) eddy currents. Previous AiResearch experience with NDE techniques to detect cracks in the TSCP700 compressor disk dovetails had shown that X-ray and image enhancement techniques could be used only if the exact location and direction of the fatigue crack was known, and that X-ray was not a viable technique for locating tight cracks. Consequently, this approach was not pursued further in this program.

Ultrasonic inspection techniques to detect cracks in complex geometric shapes (such as dovetails and firtrees) have not been developed by AiResearch. Alternately, discussions were held in November, 1977, with personnel at the Rockwell Science Center, Thousand Oaks, California, to examine the possibility of employing ultrasonics for crack detection. The intent of these discussions was to ascertain the potential of existing or emerging ultrasonic methods for dovetail/firtree crack detection, and to estimate the degree of development required for the identified approaches. Several ultrasonic methods and an eddy-current technique were proposed as having potential to detect 0.003- to 0.005-inch long cracks in typical disk dovetail/firtree

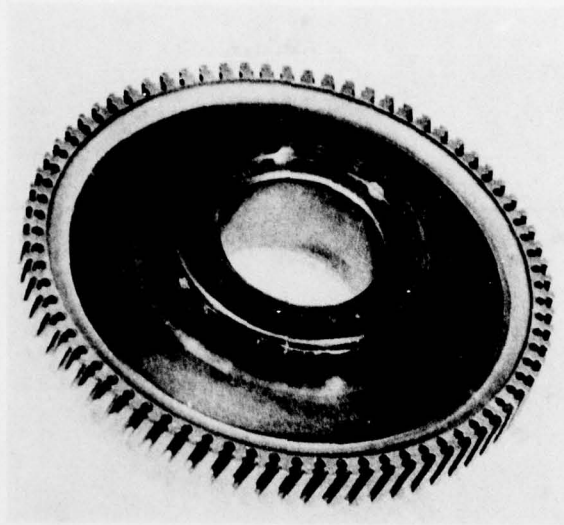

Figure 6. TSCP700 High-Pressure Turbine Disk.

TABLE 3. RETIRED TSCP700 TURBINE DISK  
HISTORY AND INSPECTION RESULTS.

Disk Serial No.	Reported Number Of Service Hours	Number of Cracked Firtrees
2909	3535	0
90309	6861	20
90149A	7055	47
727	954	56

geometries. These methods are ranked as follows in order of increasing developmental difficulty:

- o Ultrasonic scattering; frequency analysis using signal processing techniques.
- o Ultrasonic through-transmission; axially at the dovetail/firtree base.
- o Ultrasonic shear wave; incident on the platform inner diameter.
- o High-frequency eddy current; Yttrium Iron Garnet (YIG) probe sensitive to resonant frequency changes.

It was determined that no ultrasonic inspection procedures were currently available for immediate application to the dovetail/firtree crack problem. All the discussed methods required development that was beyond the scope of this program.

Fluorescent penetrants, especially the sensitive Group VI types, can be used to detect fatigue cracks in both Ti-6Al-4V and Waspaloy. However, there have been cases where this technique has failed to detect cracks that have been held closed by high compressive residual stresses. The sensitive penetrants were used throughout this program on the Waspaloy disks because the cracks were open, but not on the Ti-6Al-4V disks, since previous compressor disk experience had shown the cracks to be extremely tight and not always detectable due to their location within the slots.

#### 2.1.2.1 Ti-6Al-4V Compressor Disks

Eddy-current NDE techniques were considered for use both on the compressor disks and the turbine disks. Prior to the inception

of this program, AiResearch had developed an eddy-current technique to detect cracks and to measure their severity (depth) in the TSCP700 compressor disk dovetails. Basically, the technique uses a formed probe which fits the dovetail slot and has coils located in the regions most apt to contain a crack.

The eddy-current probe is shown in the disk in Figure 7. The probe is pushed through the slot in the disk and its output is measured on an oscilloscope. The output can be read directly in units that are related to linear crack depth. This correlation with approximate crack depth has been established through the sectioning of numerous disks and visually measuring the actual crack depth. The technique is most accurate in the 0.012- to 0.040-inch depth range with accuracy falling off at both extremes.

The twenty-four field-service Ti-6Al-4V disks were examined by this eddy-current technique. Since each of the 29 dovetail slots can have two cracks (one on each side), the maximum number detectable is 58. Table 1 (previously shown) gives the disk serial number, the approximate number of cycles (if available), and the number of cracks detected at various depths.

Figure 8 shows a large crack, which has grown to the face of the disk. The cracks usually grow to depths greater than 0.040-inch before appearing on the disk face. If disks are cycled beyond crack detection on the faces, a failure mode, as illustrated in Figure 8, results.

#### 2.1.2.2 Waspaloy Turbine Disks

Although AiResearch did not have prior experience in measuring crack depths in turbine disk firtree slots by eddy current, it was felt that a technique similar to that used on

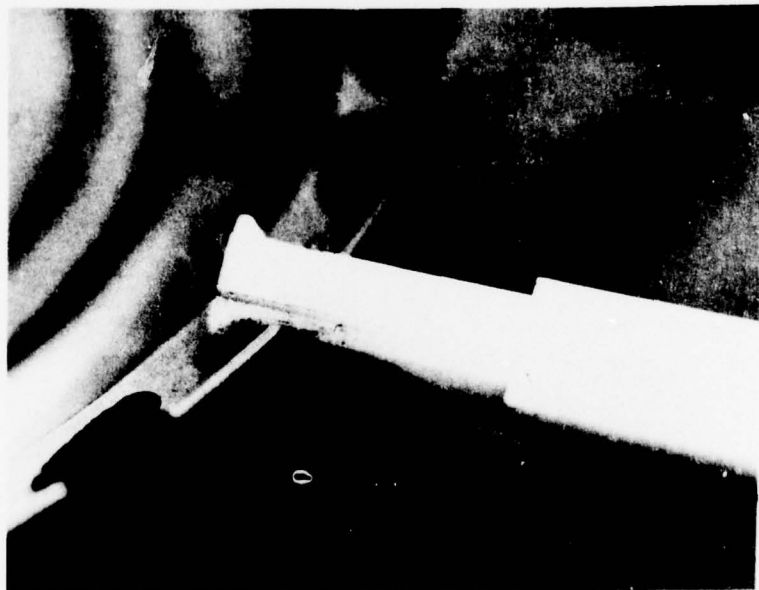

Figure 7. Eddy-Current Probe in TSCP700 Compressor Disk.

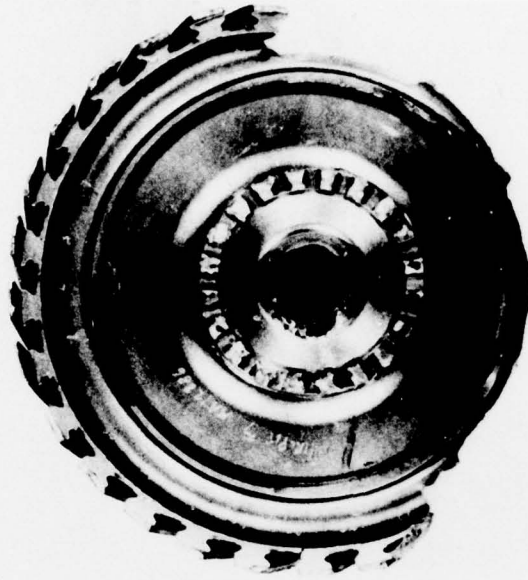

Figure 8. Ti-6Al-4V Compressor Disk Showing a Relatively Large Crack which has Propagated to the Surface (Left, Arrow) and the Result of Prolonged Cycling with a Crack Evident (Right) on the Surface.

compressor disk dovetail slots could be perfected. Probes were made (containing eddy-current coils) to fit into the firtree slots of the GTCP660 disks. The eleven field-service retired disks and the three new disks were checked. The results for the field-service returned disks are given in units of eddy-current oscilloscope output in Table 4. All of the disks were also inspected by fluorescent penetrants (sensitive Group VI) and visual (40X), with the result that none of the 72 firtrees in any of the 11 disks inspected showed a crack. Since there was no eddy-current crack depth standard developed for the firtrees, it was assumed that all the readings indicated a zero crack depth, and the difference in units may have reflected damage in the firtree region from rivet removal or from the original broaching operation. It was also assumed that any fatigue damage, at the base of the firtrees, was subsurface.

When the TSCP700 Waspaloy turbine disks were used in place of the GTCP660 disks, the decision was made not to use eddy-current techniques since the cracks were readily detected by fluorescent penetrants.

### 2.1.3 Dimensional Measurements

All twenty-four TSCP700 compressor disks and all eleven GTCP660 turbine disks returned from field-service were dimensionally inspected in critical locations. The objective was to establish a baseline for comparing the same dimensions to be taken after HIP and heat treatment. Table 5 gives the critical dimensions measured in the compressor disks. (Dimension locations are shown in Figure 9). Note that only one dimension of the disk runout measurements is out of original blueprint tolerance.

The critical dimensions on the Waspaloy GTCP660 turbine disks were measured when fixtured on the curvic couplings.

TABLE 4. EDDY-CURRENT INSPECTION RESULTS OF FIELD-SERVICE RETURNED WASPALOY TURBINE DISKS FOR THE GTCP660 ENGINE.

Disk S/N	Number of Firtrees Having Indicated Eddy-Current Readings*			
	0	1	2	3 and above
1-18040-1351	57	14	1	0
0-18040-255	61	10	1	0
0-18040-320	64	8	0	0
1-18040-2425	64	8	0	0
8-18040-813	64	7	1	0
0-18040-1140	54	16	2	0
0-18040-1187	62	9	1	0
0-18040-1190	62	10	0	0
0-18040-1316	54	16	2	0
8-18040-2370	58	11	2	1
8-18040-2391	62	9	1	0

\* Eddy-current readings are in dimensionless units.

o It is assumed that all readings indicate zero crack depth since cracks were not located by fluorescent penetrants or visually.

TABLE 5. DIMENSIONS MEASURED ON TSCP700 COMPRESSOR DISKS  
PRIOR TO HIP AND HEAT TREATMENT.

Location	Perpendicularity (1)		Radial Runout B (2)	Face Runout C (2)	Dia. Across Dovetails D (Variation from REF)
	Face to Bore A	Within 0.002 Inch			
Drawing Limits	Within 0.002 Inch		0.001 Inch Max.	0.001 Inch Max.	
Disk S/N					
-1706	0.002		0.0002	0.0002	-0.002
-1728	0.002		0.0008	0.0002	0.000
-1738	0.002		0.0004	0.0002	-0.002
-0799	0.0005		0.0004	0.0002	-0.001
-1347	0.001		0.0003	0.0002	-0.002
-1356	0.001		0.0004	0.0002	-0.002
-1427	0.001		0.0008	0.0002	-0.002
-2551	0.001		0.0002	0.0001	-0.002
-2561	0.001		0.0001	0.0001	0.000
-0324	0.003(3)		0.001	0.0006	-0.002
-0717	0.001		0.0006	0.0002	-0.003
-4731	0.001		0.0003	0.0001	-0.002
-4740	0.002		0.0003	0.0003	-0.002
-4774	0.001		0.0004	0.0002	-0.002
-4778	0.001		0.0004	0.0001	-0.002
-4802	0.001		0.0005	0.0002	-0.002
-4804	0.001		0.001	0.0003	-0.002
-4829	0.002		0.0005	0.0004	-0.001
-4831	0.001		0.0004	0.0003	-0.004
-4843	0.001		0.0003	0.0001	-0.001
-4845	0.001		0.0005	0.0001	-0.002
-1883	0.001		0.0004	0.0001	-0.004
-2606	0.000		0.0009	0.0001	-0.003
-2718	0.000		0.0006	0.0002	-0.004

(1) Refer to dimension locations shown in Figure 9.

(2) Located from curvic coupling.

(3) Out of drawing tolerance.

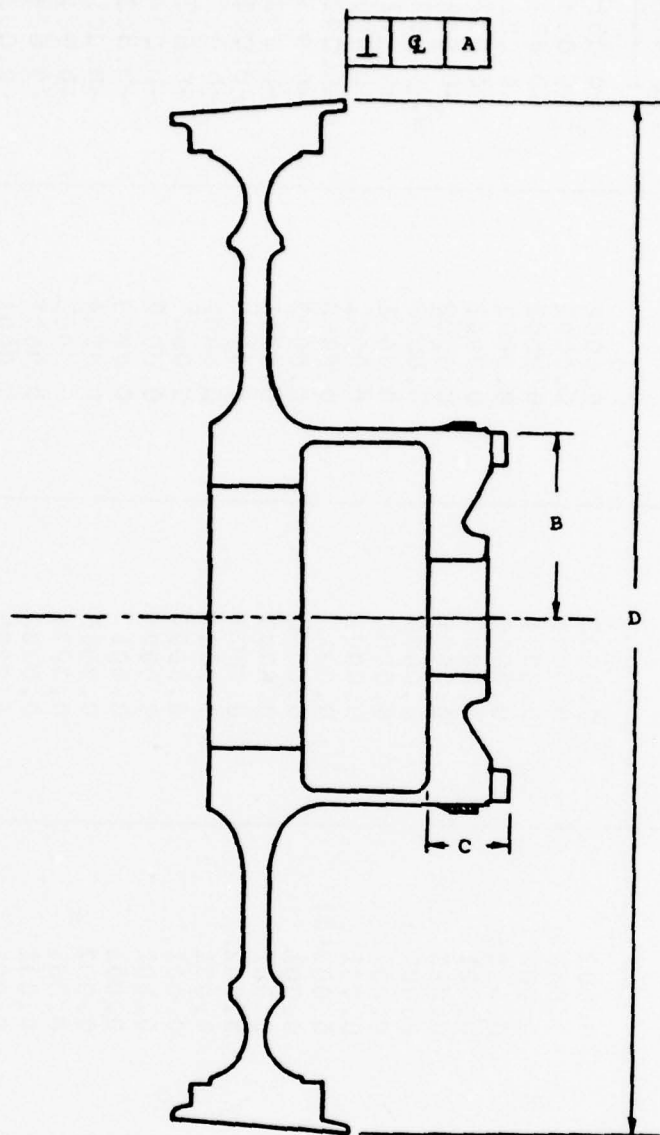

Figure 9. Location of Dimensional Measurements Taken On Field-Service Compressor Disks.

The results are given in Table 6. (Dimension locations are shown in Figure 10). Two disks exceed print limits on radial runout and three disks exceed print limits on face runout. The TSCP700 turbine disks did not have dimensional measurements taken.

#### 2.1.4 Metallurgical Evaluation

The metallurgical evaluation of the field-service compressor and turbine disks for this program consisted of microstructural examinations and mechanical property determinations. Transmission electron microscopy (TEM) was performed on selected samples taken from blade attachment regions of the disks. The purpose was to determine dislocation densities present in field-service material for comparison later with HIPped material. The work was performed by Dr. J.C. Williams and associates at Carnegie-Mellon University in Pittsburgh.

##### 2.1.4.1 Ti-6Al-4V Compressor Disk

Figure 11 shows how five compressor disks were sectioned for metallurgical samples, and the approximate locations of the mechanical property samples taken. Three halves of disks, S/N 4740, 4774, and 4845 were retained and were subjected to HIP. They subsequently were sectioned for metallurgical samples with the results being compared to the original condition (refer to Section 3.4). Both halves of disks S/N 1347 and 2551 were used for samples. Table 7 gives the specimen code numbers and their use.

Table 8 gives the room-temperature tensile test results on the Ti-6Al-4V samples removed from the disks and compared to

TABLE 6. DIMENSIONS MEASURED ON GTCP660 TURBINE DISKS PRIOR TO HIP AND HEAT TREATMENT.

Location Drawing Limits Disk S/N	Radial Runout A (1)	Face Runout B	Reference C O.D. (REF)	Dia. Across Firtrees D (Variation from REF.)
	0.0006 Inch Max.	0.0004 Inch Max.		
-1351	0.0012 (2)	0.0010 (2)	11.202 11.200	+0.0010
-255	0.0004	0.0008 (2)	11.205 11.204	0.0000
-320	0.0005	0.0005 (2)	11.206 11.200	+0.0010
-2425	0.0003	0.0002	11.205 11.203	+0.0010
-813	0.0003	0.0003	10.4820	+0.0021
-1140	0.0002	0.0001	10.4865	+0.0024
-1187	0.0007 (2)	0.0003	10.476 10.474	+0.0020
-1190	0.0003	0.0001	10.488 10.487	+0.0010
-1316	0.0004	0.0004	10.4825	+0.0036
-2370	0.0004	0.0002	10.490	+0.0010
-2391	0.0006	0.0004	10.4895 10.4800	-0.0038

(1) Refer to dimension locations shown in Figure 10.

(2) Out of drawing tolerance.

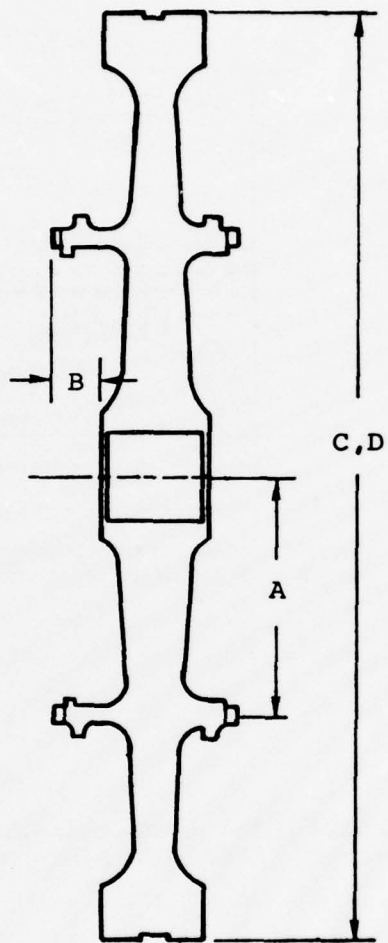

Figure 10. Location of Dimensional Measurements Taken on Field-Service Turbine Disks.

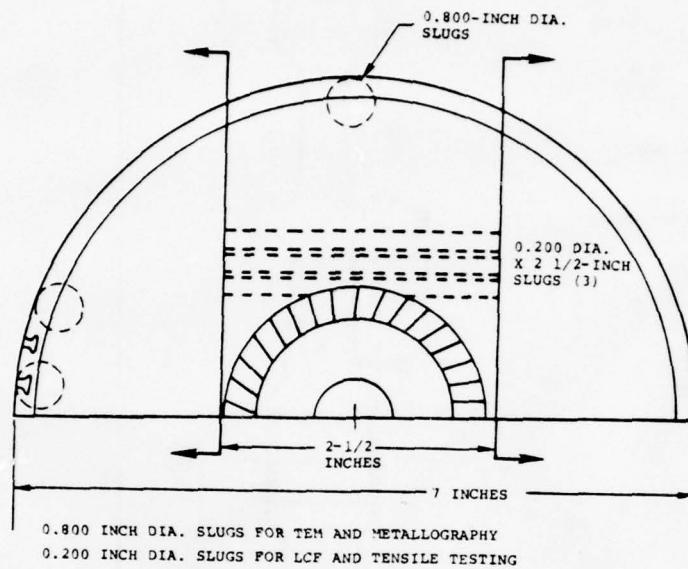

Figure 11. Metallurgical Sample Locations from Field-Service Returned Ti-6Al-4V Alloy Compressor Disks.

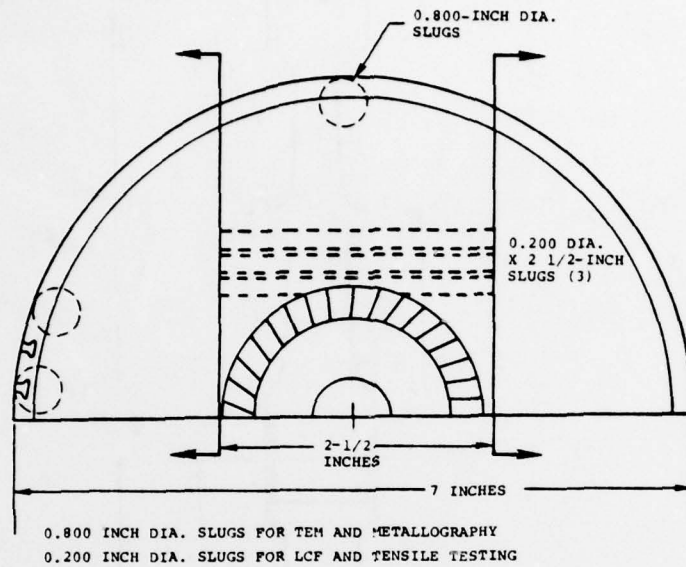

Figure 11. Metallurgical Sample Locations from Field-Service Returned Ti-6Al-4V Alloy Compressor Disks.

TABLE 7. SAMPLE IDENTIFICATION FOR FIELD-SERVICE RETURNED COMPRESSOR DISKS.

Disk S/N	Sample Number	Use	Dovetail Crack Depth - Eddy-Current NDE*
4740	40A	Metallography	0.009 Inch Crack
	40B	TEM+Metallography	0.006 Inch Crack
	40-1	LCF	-
	40-2	LCF	-
	40-3	Tensile	-
4774	74-A	Metallography	0.009 Inch Crack
	74-B	Metallography	0.006 Inch Crack
	74-1	LCF	-
	74-2	LCF	-
4845	74-3	Tensile	-
	45-A	TEM+Metallography	0.015 Inch Crack
	45-B	Metallography	0.000 Inch Crack
	45-1	LCF	-
2551	45-2	Extra	-
	45-3	Tensile	-
	51-A	Metallography	0.018 Inch Crack
	51-B	TEM+Metallography	0.015 Inch Crack
	51-1	LCF	-
	51-2	LCF	-
	51-3	Tensile	-
1347	51-4	LCF	-
	51-5	LCF	-
	51-6	Tensile	-
	47-A	Metallography	0.012 Inch Crack
	47-B	Extra	0.012 Inch Crack
	47-1	LCF	-
	47-1A	LCF	-
47-2	Tensile	-	
	47-2A	LCF	-

\*Readings of 0.000 through 0.009 inch do not conclusively indicate a crack.

TABLE 8. Ti-6Al-4V TENSILE PROPERTIES AT ROOM TEMPERATURE - BEFORE HIP.

Test Bar No.	0.2% Y.S. (ksi)	Ultimate Tensile Strength, (ksi)	Percent Elongation	Percent R of A
40-3	128.0	138.5	11.6	45.5
45-3	127.9	137.8	10.2	37.6
47-2A	136.7	146.3	11.8	36.9
51-3	139.4	148.4	12.8	49.0
51-6	139.1	147.9	12.0	41.8
74-3	132.8	142.6	13.6	38.8
AiResearch Specification and AMS4928 Minimums	120.0	130.0	10.0	25.0

AiResearch Standards and the AMS 4928 Specification. All values exceed the specification minimums

To obtain baseline LCF data test bars were machined from the Ti-6Al-4V compressor disks and tested under load control (bar under tension at all times) at room temperature and at calculated stresses ranging from 85 to 145 ksi. The bars were notched and the  $K_T$  was approximately 2.0. (The calculated stresses do not utilize the stress concentration factors.) Figure 12 is a plot of the data obtained. The LCF test results after HIP were compared to this curve. Metallographic samples were prepared, and typical photomicrographs are shown in Figure 13. The microstructures varied in the amount of primary alpha and grain size as would be expected in the mill-annealed starting product.

The TEM analysis of dislocation densities centered around the dovetail corner region of the disks. Three disks were sectioned and thin films were produced. Typical TEM photographs are shown in Figure 14. The field-service dislocation density was estimated to be in the range of  $10^9$  to  $10^{10}$  per square centimeter.

#### 2.1.4.2 Waspaloy Turbine Disk

Figure 15 shows how three GTCP660 turbine disks were sectioned for metallurgical samples, and the approximate locations of the samples taken. As in the case of the compressor disk, one half of each disk was saved for post-HIP and heat-treatment evaluation. Table 9 gives the specimen code numbers and their use. Since none of the firtrees were cracked, the metallographic samples were selected at random.

Table 10 gives the 1000°F tensile test results on the Waspaloy samples removed from the field-service disks and

- ROOM TEMPERATURE
- LOAD CONTROL,  $A = 1.0$
- NOTCH BAR,  $K_T = 2$
- WEB SECTIONS

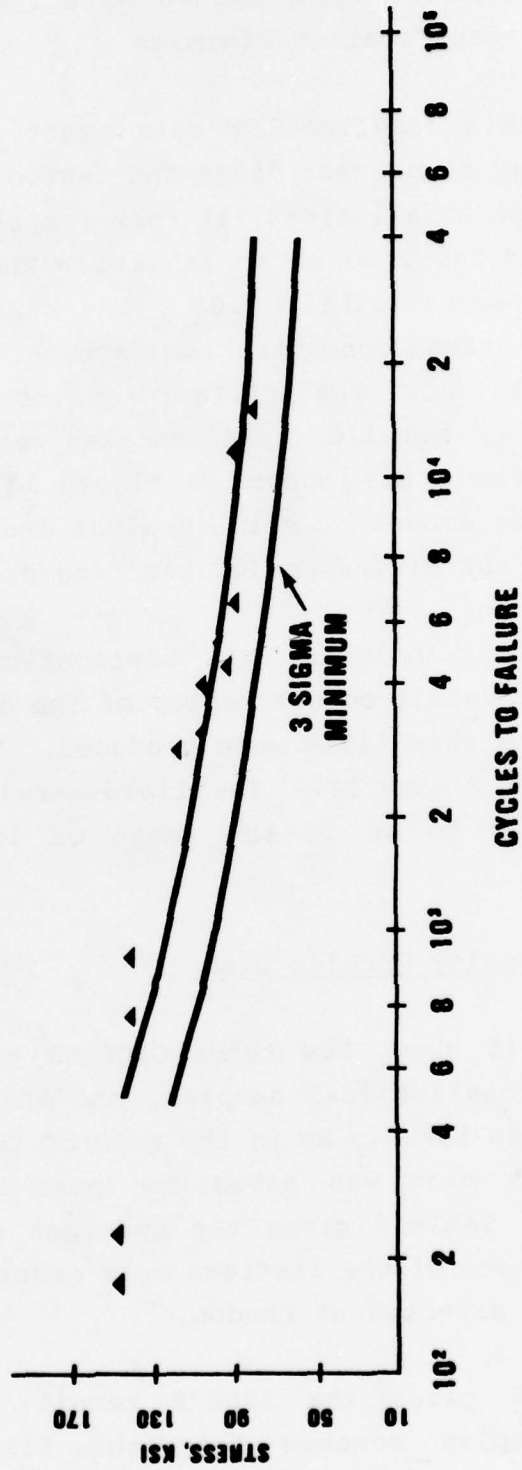
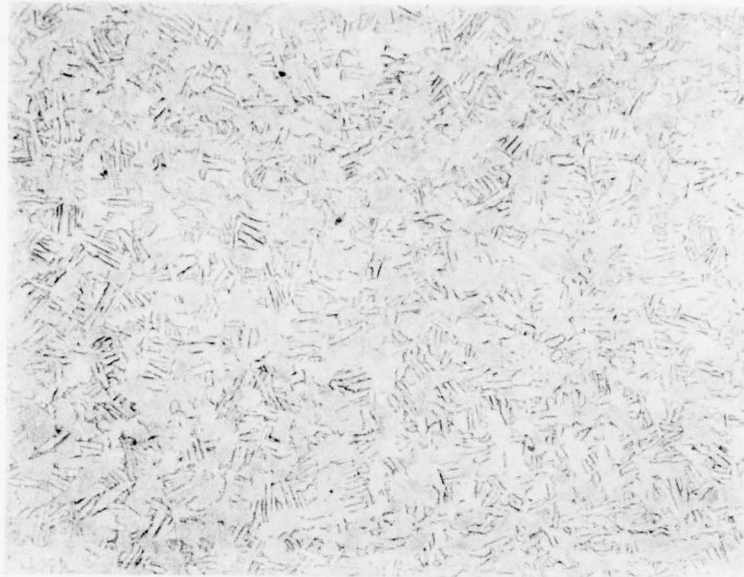

Figure 12. Low-Cycle-Fatigue Results for Ti-6Al-4V Compressor Disk Test Specimens.



DISK S/N 4845

MAG: 250X

ETCHANT: HF + HNO<sub>3</sub>

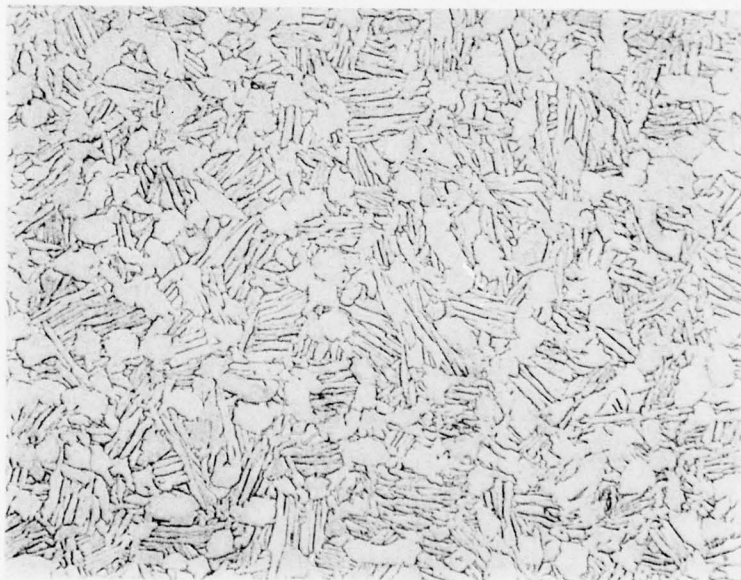

DISK S/N 1347

MAG: 250X

ETCHANT: HF + HNO<sub>3</sub>

Figure 13. Typical Microstructures of Ti-6Al-4V Compressor Disks Returned from the Field.

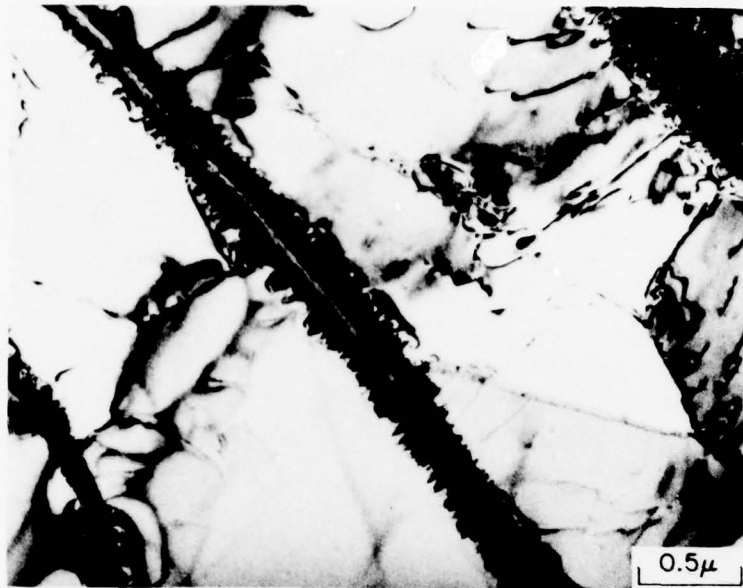

DISK S/N 4740

MAG: 17,000X



DISK S/N 4845

MAG: 17,000X

Figure 14. TEM Examination of Field-Service Compressor Disks in the Region of the Dovetails.

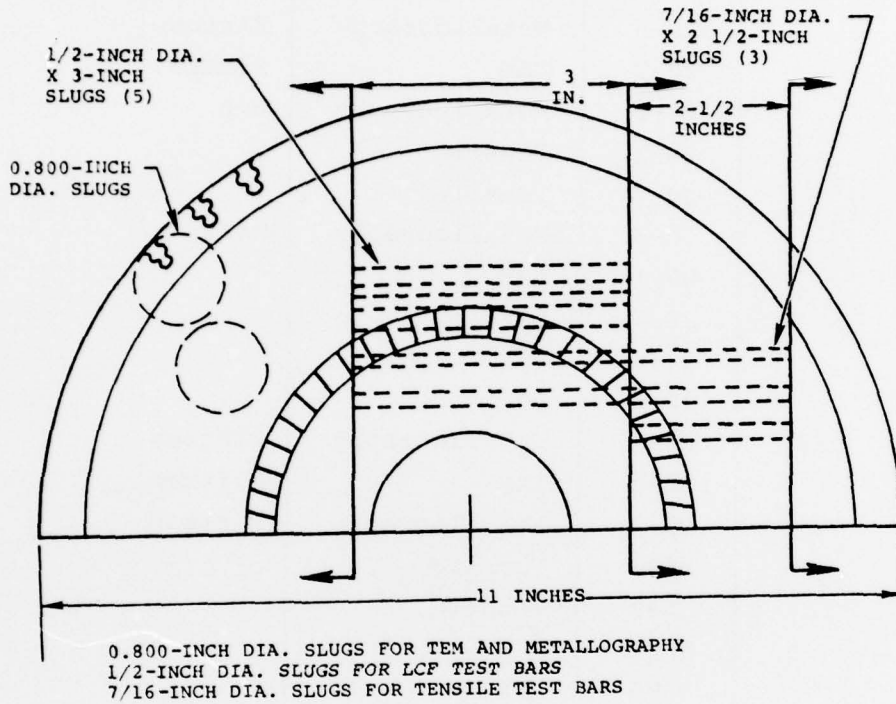

Figure 15. Metallurgical Sample Locations from Waspaloy Turbine Disks.

TABLE 9. SAMPLE IDENTIFICATION FOR FIELD-SERVICE TURBINE DISKS.

Disk S/N	Sample I.D.	Use	Remarks
320	20-A	Metallography	Firtree
	20-B	Metallography	Firtree
	20-C	TEM	Firtree
	20-D	Metallography	Web
	20-1	Tensile	
	20-2	Tensile	
	20-3	Metallography	Web
	20-4	LCF	
	20-5	LCF	
	20-6	LCF	
255	55-A	Metallography	Firtree
	55-B	TEM	Firtree
	55-C	Metallography	Firtree
	55-1	Tensile	
	55-2	Tensile	
	55-4	LCF	
	55-5	LCF	
	55-6	LCF	
1351	55-7	LCF	
	55-8	Metallography	Web
	51-A	Metallography	Firtree
	51-B	TEM	Firtree
	51-C	Metallography	Firtree
	51-1	Tensile	
	51-2	Tensile	
	51-4	LCF	
51-5	LCF		
51-6	LCF		
51-7	LCF		

TABLE 10. WASPALOY TENSILE PROPERTIES AT 1000°F GENERATED FROM FIELD-SERVICE DISKS.

Test Bar Number	0.2% Y.S. (ksi)	Ultimate Strength (ksi)	Percent Elongation	Percent R of A
20-1	110.7	158.6*	18.4	24.9
20-2	113.1	162.4	20.9	19.6
51-1	112.5	164.4	18.7	23.2
55-1	113.7	165.0	18.8	22.6
55-2	114.1	163.7	15.4	19.0
AiResearch Specification Minimums	110.0	160.0	12.0	15.0

\* Below minimum value.

compared to the AiResearch Specification minimums. Only one ultimate strength value does not exceed the minimum.

The LCF test bars machined from the GTCP660 APU Waspaloy turbine disks were tested under load control (bar under tension at all times) at 1000°F and at calculated stresses ranging from 120 to 155 ksi. The bars were notched and the  $K_T$  was approximately 2.0. (The calculated stresses do not utilize the stress concentration factor.) Figure 16 shows the results obtained. These curves were used as the basis for comparison of field-retained disks after HIP processing. Metallographic samples were prepared and typical photomicrographs are shown in Figure 17. The structures from disk to disk were fairly uniform and grain size variations were small.

The TEM analysis of dislocation densities centered around the base of the disk firtrees. Three disks were sectioned and thin films prepared. Typical TEM photographs are shown in Figure 18. The dislocation density was estimated to be  $10^8$  per square centimeter.

#### 2.1.5 Cyclic-Spin Testing

Cyclic-spin testing in an ambient temperature evacuated whirlpit has a two-fold purpose. The first is to establish the blade attachment dovetail low-cycle-fatigue (LCF) life of new disks, and second, to determine the residual life of field-service retired disks. The spin testing of the compressor and turbine disks is covered separately in the following paragraphs.

##### 2.1.5.1 Ti-6Al-4V Compressor Disks

The test conditions for the TSCP700 APU first-stage compressor disks were previously developed by AiResearch through

- 1000°F TEST TEMPERATURE
- LOAD CONTROL, A = 1.0
- NOTCH BAR,  $K_T = 2$
- WEB SECTIONS

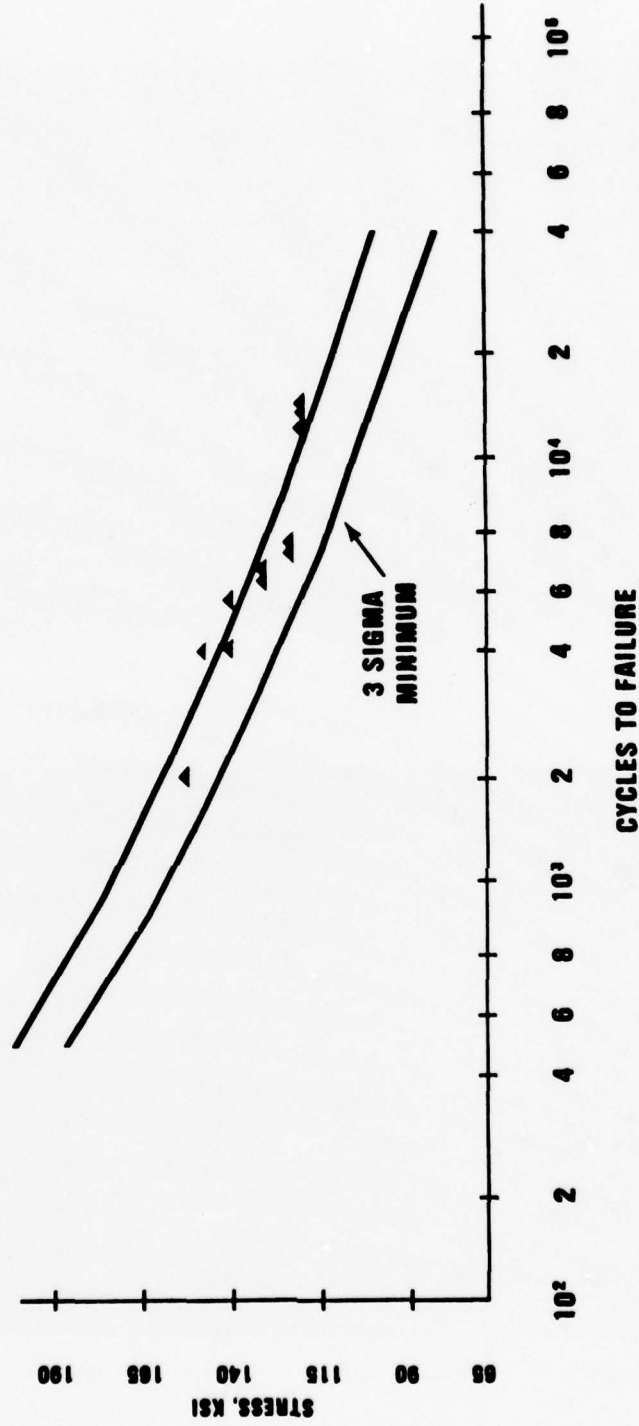
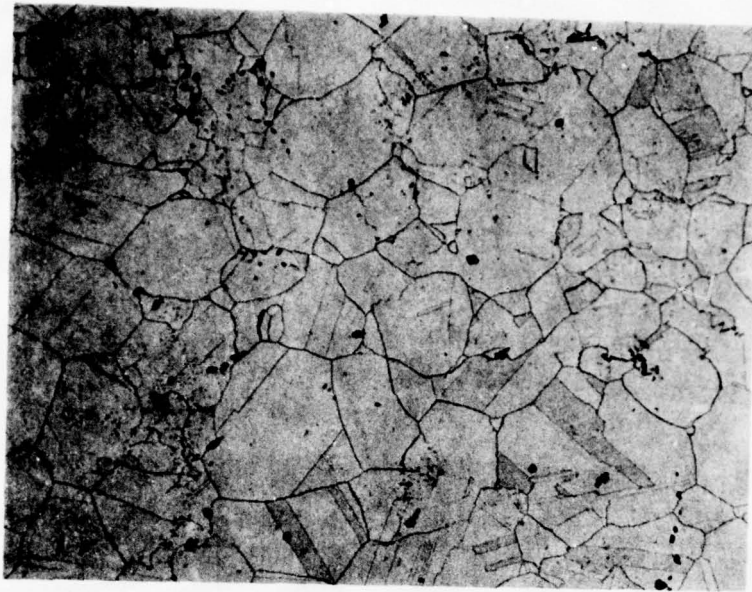
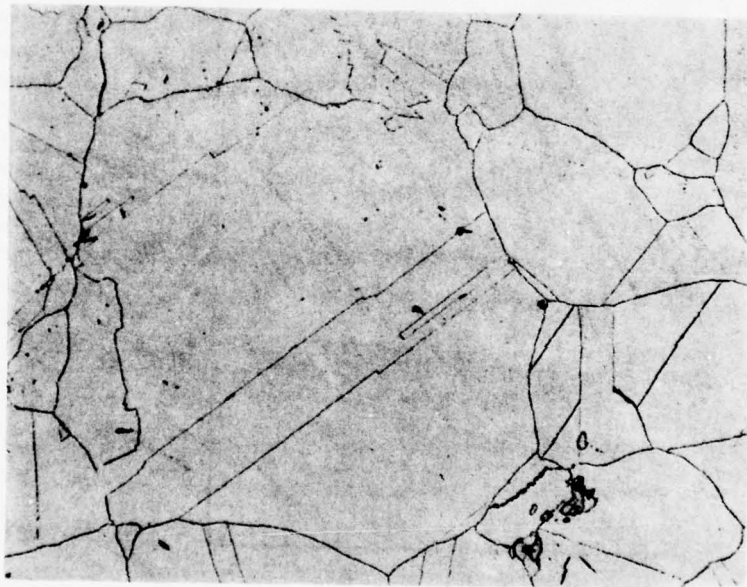

Figure 16. Low-Cycle-Fatigue Results for Field-Service Waspaloy Turbine Disk Test Specimens.



DISK S/N 320

ETCHANT: KALLINGS



DISK S/N 320

MAG: 250X

ETCHANT: KALLINGS

Figure 17. Typical Microstructures of a Waspaloy Turbine Disk.

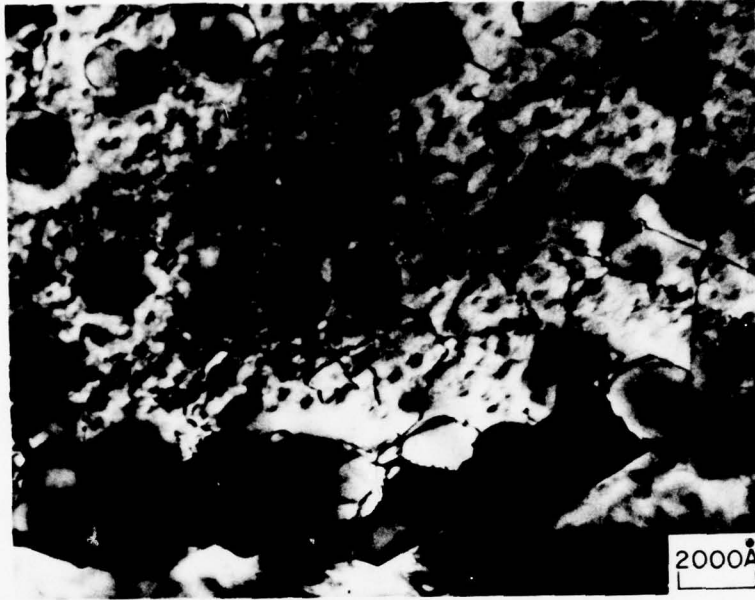

DISK S/N 320

MAG: 27,000X

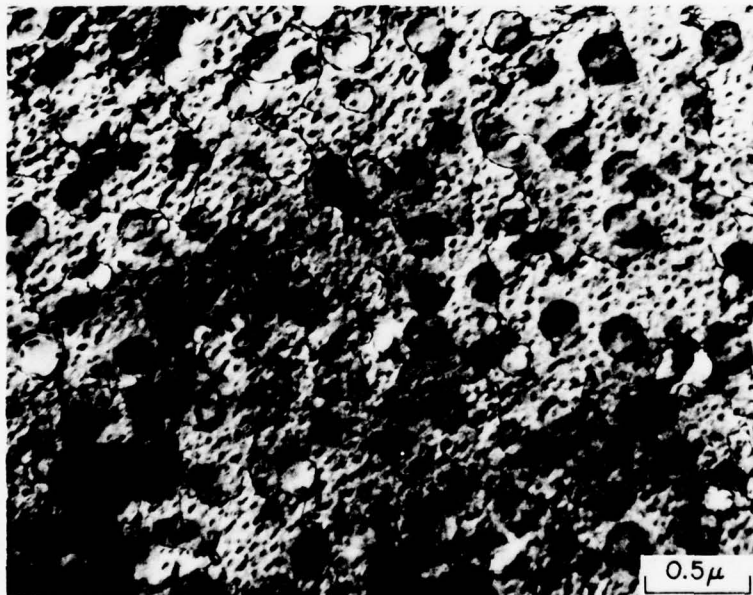

DISK S/N 1351

MAG: 17,000X

Figure 18. TEM Examination of Field-Service Turbine Disks in the Region of the Firtrees.

the testing of numerous new and field-service fully bladed disks. The maximum speed selected is 100 percent of normal operating speed (temperature corrected) and the minimum is 10 percent of normal operating speed. Spinning from physical speeds of 3000 rpm to 29,800 rpm and back to 3000 rpm constitutes one cycle.

Three new compressor disks were sequentially whirlpit cycled, with periodic shutdowns for deblading and eddy-current inspection of the dovetails to detect cracks. Figure 19 shows the whirlpit setup for the compressor disk. Table 11 summarizes the testing and shows the three disks were suspended from further testing at 5000, 6500, and 10,500 cycles, respectively. The disks did not burst or fracture, but Disks A and C were rapidly approaching catastrophic failure.

Prior to the initiation of this program, four field-service retired disks had been cyclic-spin tested to determine the LCF life remaining. This testing eliminated the need to perform additional testing under the contract. Two disks were cycled to 100-percent operating speed, and two disks were cycled to 91 percent of operating speed. Table 12 summarizes the testing and demonstrates a spread in life remaining from 145 cycles to 12,232 cycles, depending on the maximum test speed.

The results of spin testing the new and field-service retired disks constituted the baseline for comparison of the whirlpit testing performed on the HIPped and heat-treated disks.

#### 2.1.5.2 Waspaloy Turbine Disks

The cyclic-spin testing of the Waspaloy turbine disks consisted of two parts. The GTCP660 APU second-stage disk was spun initially, and since cracks could not be induced, it was decided

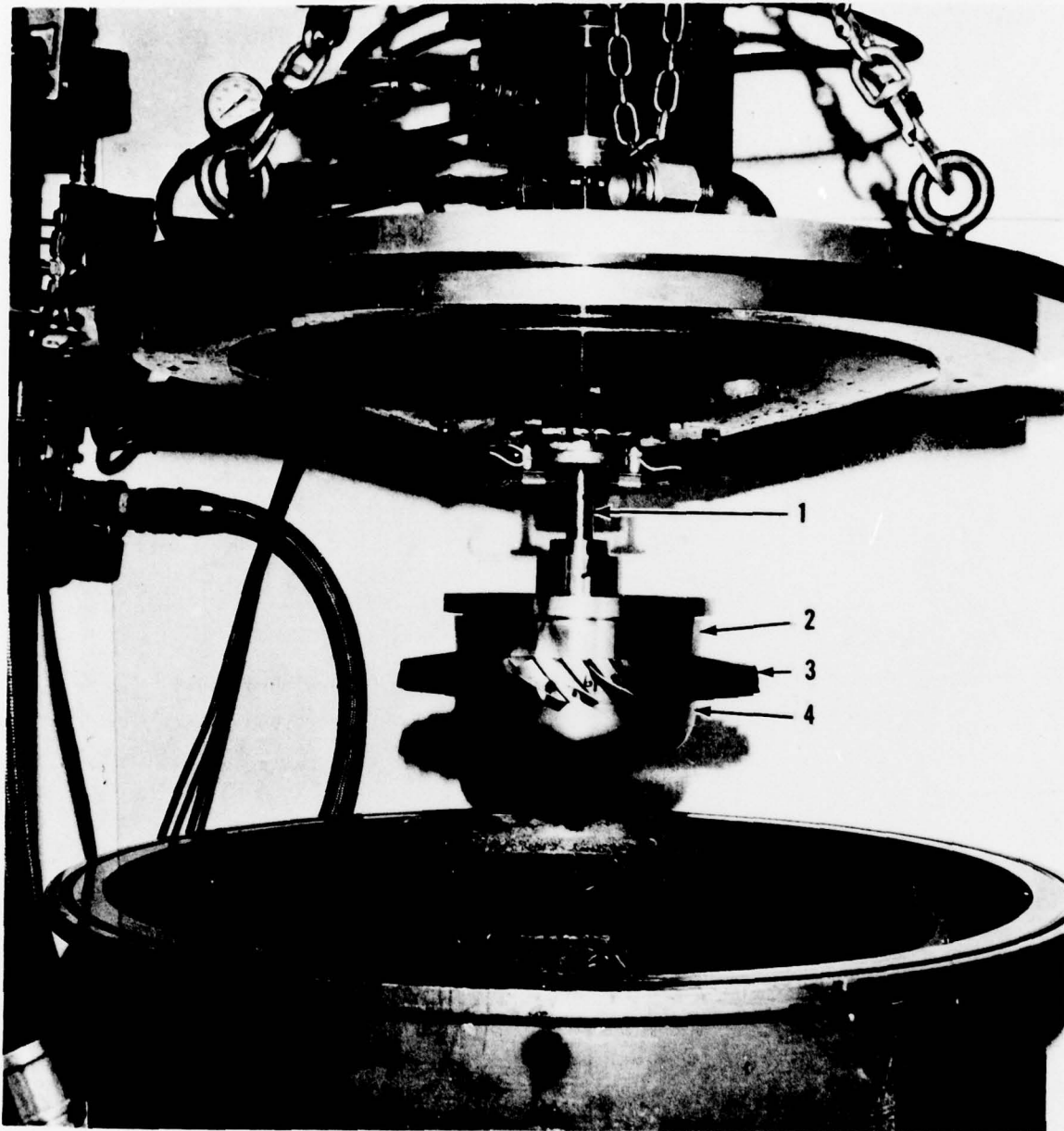

- 1 - ARBOR
- 2 - DUMMY SECOND STAGE COMPRESSOR DISK
- 3 - FIRST STAGE COMPRESSOR DISK
- 4 - SPINNER

Figure 19. Whirlpit Setup for Spin Testing Ti-6Al-4V TSCP700 Compressor Disk.

TABLE 11. SUMMARY OF NEW Ti-6Al-4V TSCP700 APU FIRST-STAGE COMPRESSOR DISK CYCLIC-SPIN TESTING.

No. Cycles	Range of Dovetail Crack Depths, Inches as Determined by Eddy Current Technique		
	Disk A	Disk B	Disk C
0	0.000-0.009*	0.000-0.009*	0.000-0.009*
2000	0.000-0.012	0.000-0.012	0.000-0.012
3250	-	0.003-0.012	-
3500	0.003-0.040	-	0.003-0.015
4000	0.006-0.051	0.003-0.015	-
4250	-	-	-
4500	-	-	0.003-0.018
5000	0.006-0.100+ 12 of 29 dove- tails cracked (disk retired)	-	-
5500	-	0.003-0.015	-
6000	-	-	0.003-0.039
6500	-	-	0.003-0.054 23 of 29 dove- tails cracked (disk retired)
7000	-	0.003-0.015	-
8500	-	0.003-0.021	-
10,500	-	0.003-0.090 18 of 29 dove- tails cracked (disk retired)	-

\*Eddy current readings from 0.000 to 0.009 inch do not necessarily indicate cracks.

TABLE 12. SUMMARY OF FIELD-SERVICE Ti-6Al-4V TSCP700 APU FIRST-STAGE COMPRESSOR DISK CYCLIC-SPIN TESTING.

Disk S/N and Maximum Percent Rated Speed	Field-Service Hours*	Field-Service Crack Depth (Max.)	No. Cycles in Whirlpit Until Failure	Total Cycles
4 (100%)	7360	0.075 Inch	145	7,505
7 (100%)	8718	0.040 Inch	2,510	11,228
5 (91%)	7331	0.040 Inch	4,512	11,843
8 (91%)	6899	Approx. 0.020 Inch	12,232	19,131

\*1 hour is considered one cycle.

to use the field service TSCP700 high-pressure turbine disk instead.

The cyclic test conditions for the GTCP660 turbine disks were previously developed by AiResearch during the progressive life extension of the disk up to a maximum of 15,000 hours. The maximum speed selected was 150 percent of normal operating speed (30,000 rpm) and the minimum selected was 3000 rpm. As in the case of the compressor disk, one cycle is defined as 3000 rpm to 30,000 rpm and back to 3000 rpm.

Since the field-service Waspaloy disks were not cracked, three disks were selected for spin testing with a two-fold purpose: (1) to generate fatigue cracks at the bottom of the fir-trees that subsequently could be oxidized, cleaned, bridged, and HIPped; and (2) to establish the fir-tree LCF baseline for used disks. Figure 20 shows the spin-test setup for these disks. The three disks were cycled to 1570, 3500, and 4500 cycles, respectively, with periodic inspections of the fir-trees by eddy current and Group VI fluorescent penetrants. Eddy-current readings increased somewhat, but cracks could not be detected by fluorescent penetrants or by a 40-power visual inspection. At that time, it appeared the eddy-current reading increase was due to scratches at the fir-tree base resulting from the removal and replacement of rivets at each inspection. Initially, the blades were retained in the fir-tree slot with O-ring cord stock for ease of blade removal. However, the O-ring cord tended to fatigue as cycles were accumulated, and riveting had to be used. Spin testing of these disks was stopped since detectable cracks were not generated.

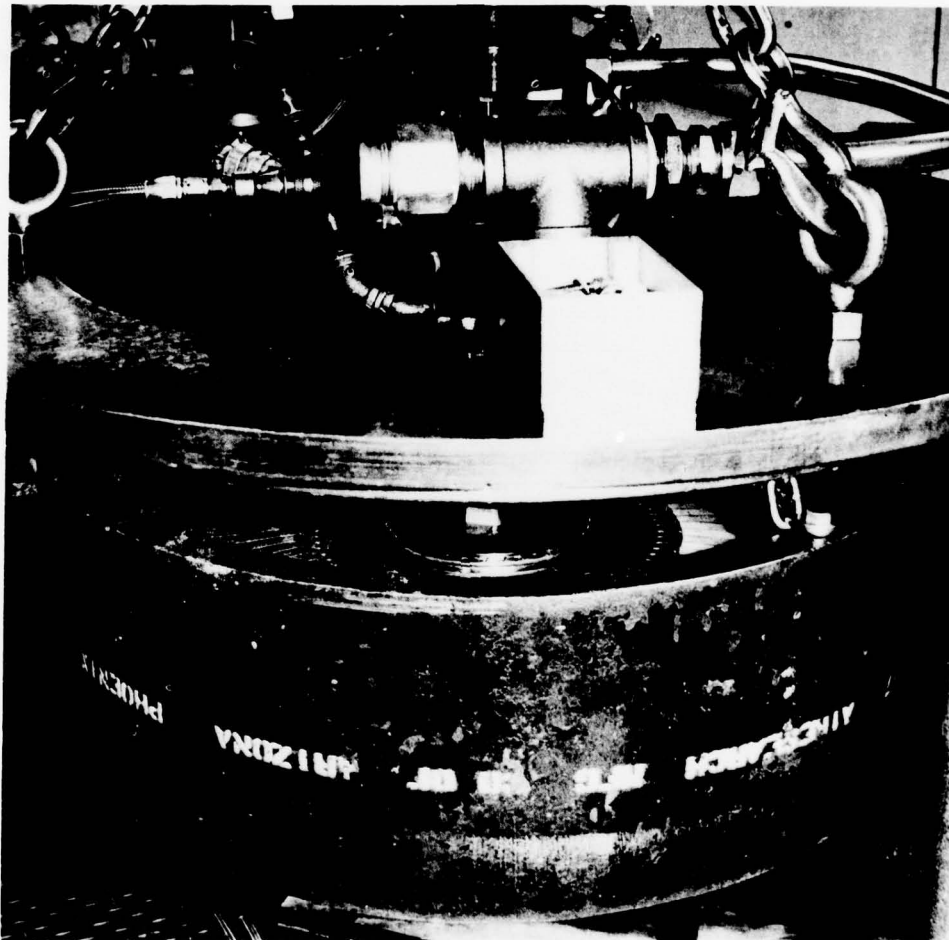

Figure 20. Spin-Test Setup for GTCP660 Engine  
Waspaloy Turbine Disk.

The TSCP700 APU Waspaloy turbine disks were available from field service, and a number had small cracks originating in the firtrees. These disks were not spin tested to establish a field-service baseline, but new disks were tested to determine the LCF baseline so that a baseline would exist when the HIP-rejuvenated disks were fatigue tested.

The test setup for the cyclic spin-testing of three new TSCP700 APU turbine disks is shown in Figure 21. The disk was spun without blades since stress calculations showed that the contribution of the blades to the total rim loading was small at overspeed conditions. Table 13 shows the results obtained on the three disks. Disk Serial No. 2911, with 7000 cycles, was examined carefully and sectioned; no cracks were found. Disk Serial No. 1799 exhibited 12 cracked firtrees (using fluorescent penetrant inspection) after 6070 cycles, and this disk was also sectioned. Figure 22 is a metallographic examination of one of these cracked firtrees, which shows a crack having both intergranular and transgranular modes. This is compared to Figure 23, which metallographically shows cracks in a field-service disk, Serial No. 90149A. These cracks are similar in appearance and mode to the cyclic spin-induced cracks, indicating that a technique exists to produce cracks in the cyclic whirlpit that resemble field-service low-cycle-fatigue cracks.

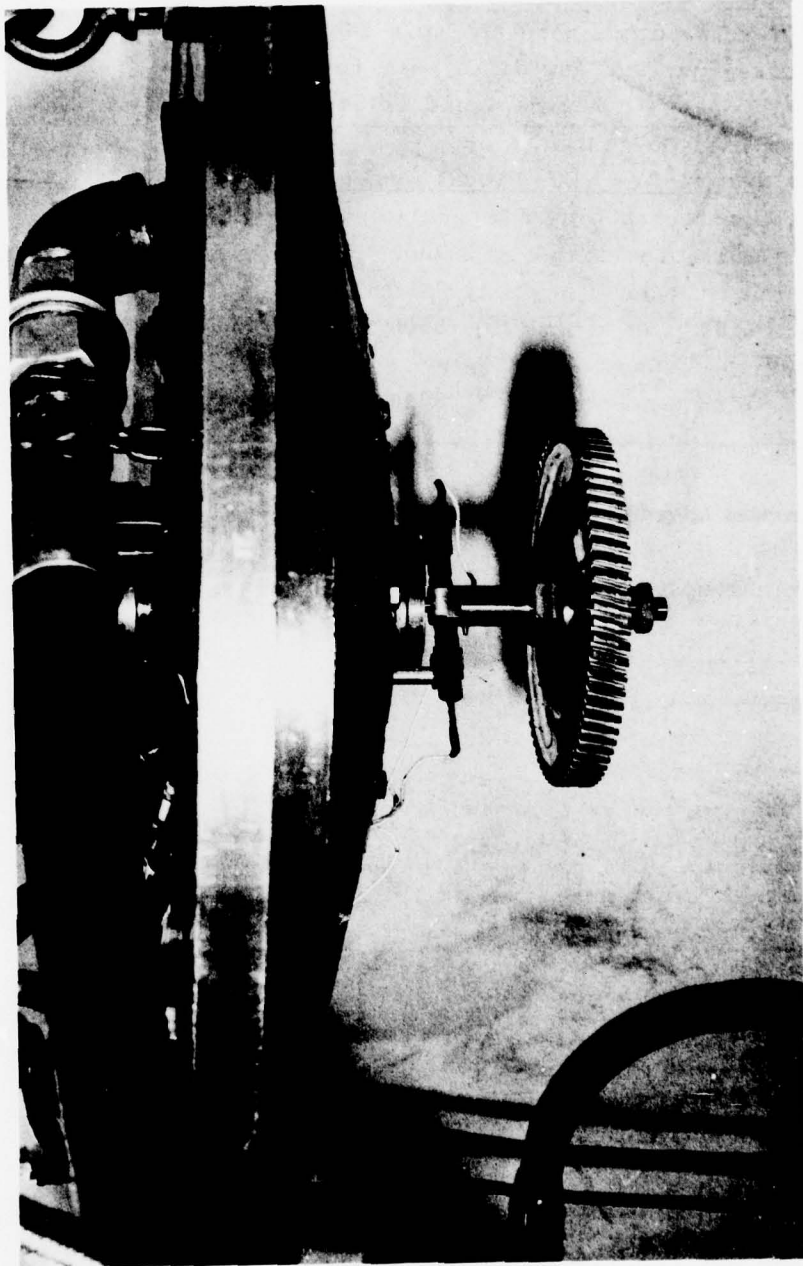

Figure 21. Spin Test Setup for Spin Testing of Waspaloy TSCP700 Turbine Disks.

TABLE 13. TSCP700 APU HIGH-PRESSURE TURBINE DISK CYCLIC-SPIN TEST RESULTS (THREE DISKS).

Disk Serial No.	Total Cycles	Number of Cracked Firtrees
2911	7000	0
2685	5500	14
1799	6070	12

Minimum speed - 52,600 rpm

Maximum speed - 52,800 rpm

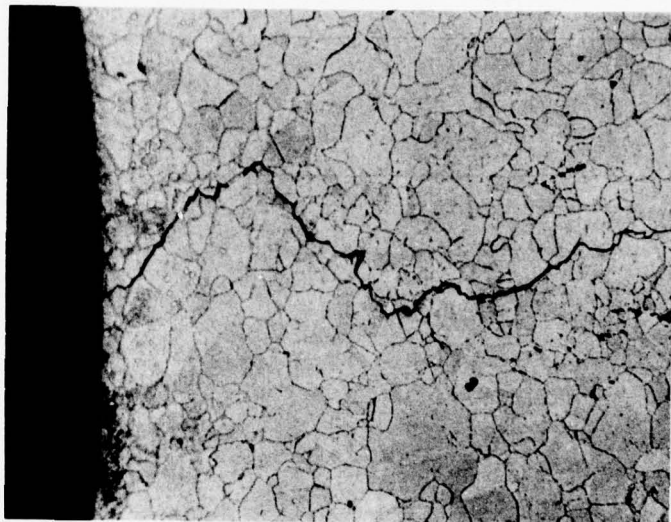

ETCHANT: KALLINGS  
MAG: 200X

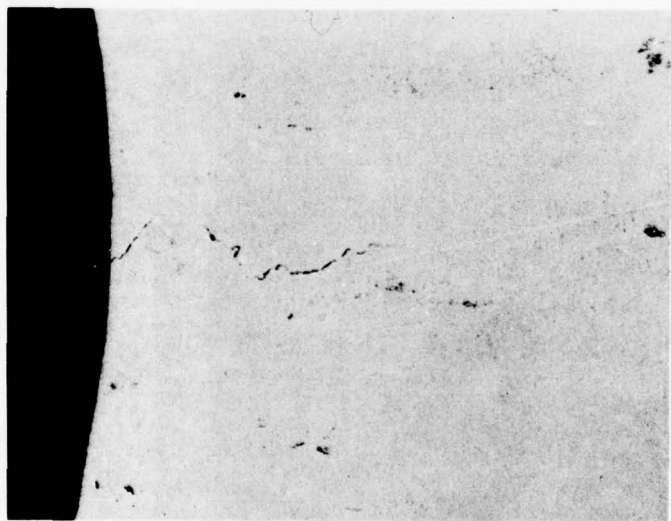

UNETCHED  
MAG: 100 X

Figure 22. Low-Cycle-Fatigue Crack Produced in 6070 Cycles by Cyclic-Spin Testing at Room Temperature, Disk Serial No. 1799.

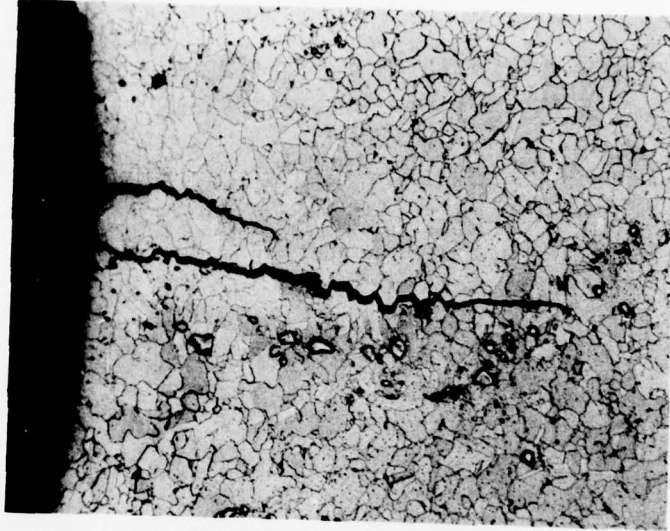

ETCHANT: KALLINGS  
MAG: 200X

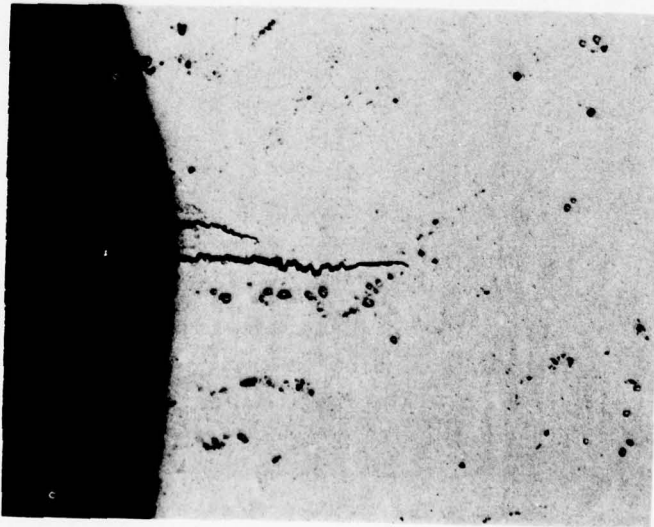

UNETCHED  
MAG: 100X

Figure 23. Low-Cycle-Fatigue Cracks Detected in Field-Service Disk Serial No. 90149A.

## 2.2 Task II - Preparation for Hot Isostatic Pressing (HIP)

Compressor disks and turbine disks selected for HIP rejuvenation require overall cleaning and bridging of fatigue cracks connected to the surface. Cleaning and bridging is required to minimize further surface contamination of the finished disks due to existing contaminants, and to prepare the crack surfaces for diffusion bonding during the subsequent HIP operation.

### 2.2.1 Cleaning Techniques

The cleaning of the field-service titanium compressor disks and the Waspaloy turbine disks differed. The compressor disk runs relatively cool (300°F maximum) and oxide scales are not found. On the other hand, the rims of the Waspaloy disks run at approximately 1200°F, and after long service times, a tenacious oxide film is exhibited.

Sample pieces of the compressor disks were sent to two sources for cleaning in conjunction with bridging of surface connected cracks. One was Koral Laboratories, Inc., St. Paul, Minnesota, who performed reverse sputtering prior to ion plating. In reverse sputtering, the part to be cleaned is heated in a high vacuum and bombarded with ionized argon gas that essentially "boils off" surface oxide and contamination. The second source was Electro-Plasma Inc., Irvine, California, where, through the use of a transferred arc in a vacuum plasma spray chamber, cleaning similar to reverse sputtering occurs.

As previously noted, cracks were not found in field-service returned GTCP660 Waspaloy turbine disks. As a result, the cleaning (and subsequent bridging) experiments were initiated on previously tested (1350° and 1500°F) Waspaloy stress-rupture bars, all of which contained multiple cracks. A number of bars were

sent to the above sources for oxide film removal by the reverse sputtering and transferred-arc processes.

An additional cleaning technique for Waspaloy was investigated. The University of Dayton Research Institute was contracted to investigate a gaseous fluorine cleaning technique that had been effective in cleaning some oxidized cast superalloys. The investigation was performed on oxidized (and cracked) Waspaloy stress-rupture bars due to the unavailability of fatigue-cracked turbine disks. The conclusions of the investigations are summarized below:

- (a) Waspaloy reacted differently to the cleaning atmosphere than other superalloys investigated previously; the other alloys were higher in gamma-prime-forming elements (Al, Ti).
- (b) The exposure to the cleaning atmosphere resulted in denuding of the gamma prime near the surface, the diffusion of the denuded layer inward, and formation of unknown surface phases.
- (c) A foreign phase (different from the original oxide) appeared in the cracks after cleaning.

The resulting recommendation from the University of Dayton was that additional work should be performed prior to using the technique on finished turbine disks. The investigation was discontinued since it was beyond the scope of this contract.

#### 2.2.2 Bridging Techniques

The fatigue crack bridging techniques investigated in this program were ion plating and vacuum plasma spraying. Ion plating is not line-of-sight dependent, and has the advantage of applying

thin, uniform, tenacious coatings on unmasked surfaces in a vacuum. Vacuum plasma spraying is line-of-sight dependent, but applies a more dense coating than normal plasma spraying.

#### 2.2.2.1 Test Samples

The Ti-6Al-4V and Waspaloy test samples, cleaned and bridged by vacuum plasma spraying at Electro-Plasma, Inc. and by ion plating at Koral Laboratories, were extensively examined by light metallography to determine the effectiveness of the coatings as potential crack seals (bridges). Figure 24 shows a crack in the dovetail of a Ti-6Al-4V compressor disk which has been bridged by ion plating. The titanium layer of plating is not well bonded to the substrate in the region of the crack, but different dovetails coated at the same time appeared to have the titanium layer well bonded to the substrate without the oxide film or gap. Figure 25 shows a comparable cracked dovetail bridged by vacuum plasma spraying pure titanium followed by pure copper. The titanium layer appears oxidized and quite porous compared to the ion-plated bridge. The copper layer also appears cracked and porous and probably would not act as an effective seal.

Waspaloy stress-rupture bars previously tested were used as test samples to evaluate bridging effectiveness in the absence of field-cracked turbine disks. Figure 26 shows the surface of a bar cleaned by reverse sputtering and bridged by ion plating with pure nickel. The cleaning appeared very effective on the surface but not in the cracks. The ion-plated layer does, in effect, bridge the crack. A thin copper plate followed by a thick layer of nickel aided in metallographic sample preparation. Figure 27 shows a before-and-after surface of a Waspaloy stress-rupture bar that was subjected to vacuum plasma spraying. The sample was lightly grit-blasted prior to being placed in the vacuum chamber for transferred-arc cleaning and plasma spraying with pure

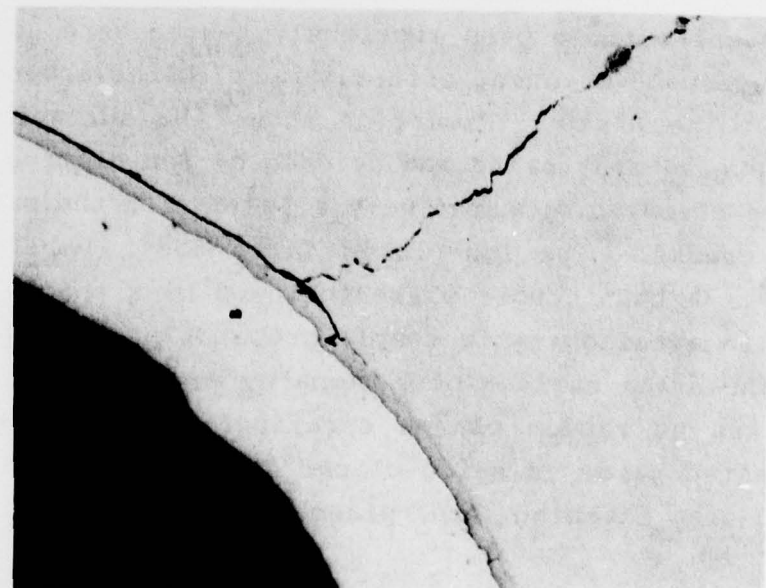

UNETCHED      MAG: 200X

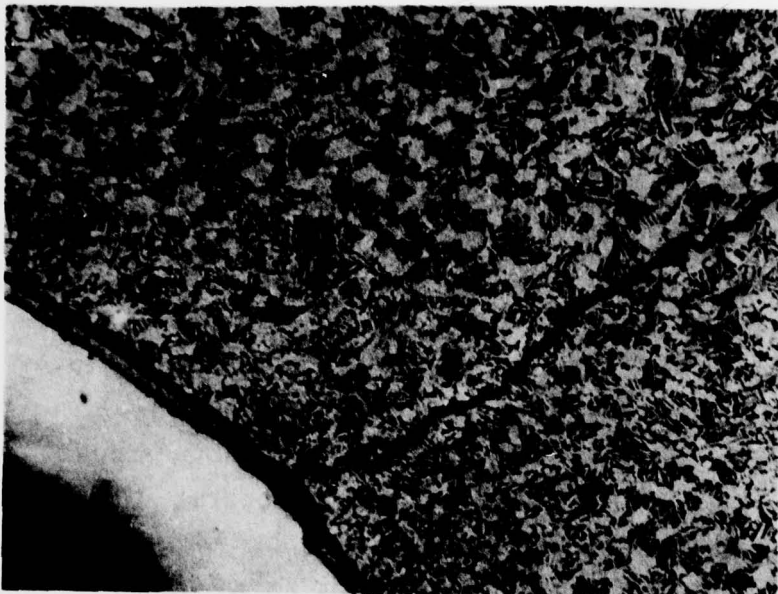

KROLLS ETCH      MAG: 200X

Figure 24. Dovetail Crack in a TI-6Al-4V Alloy Compressor Disk Test Sample Bridged by Ion Plating with Pure Titanium (A) and Pure Copper (B).

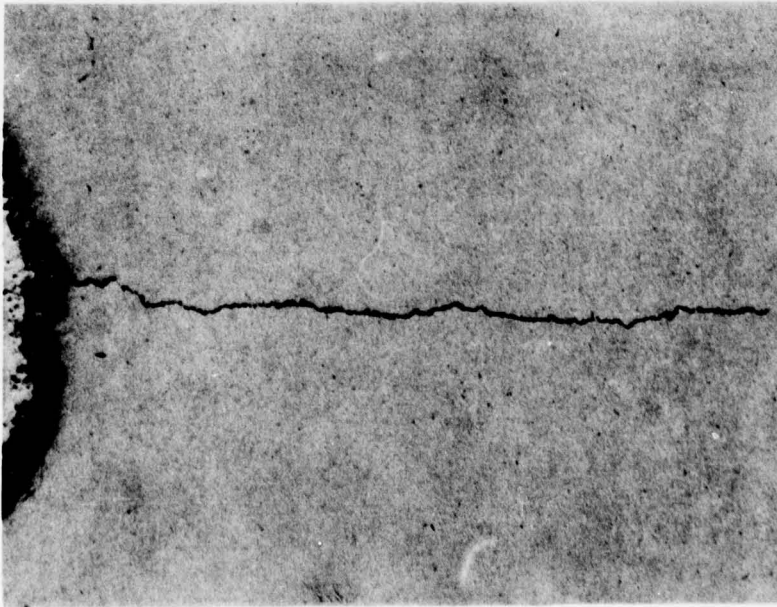

MAG: 100X

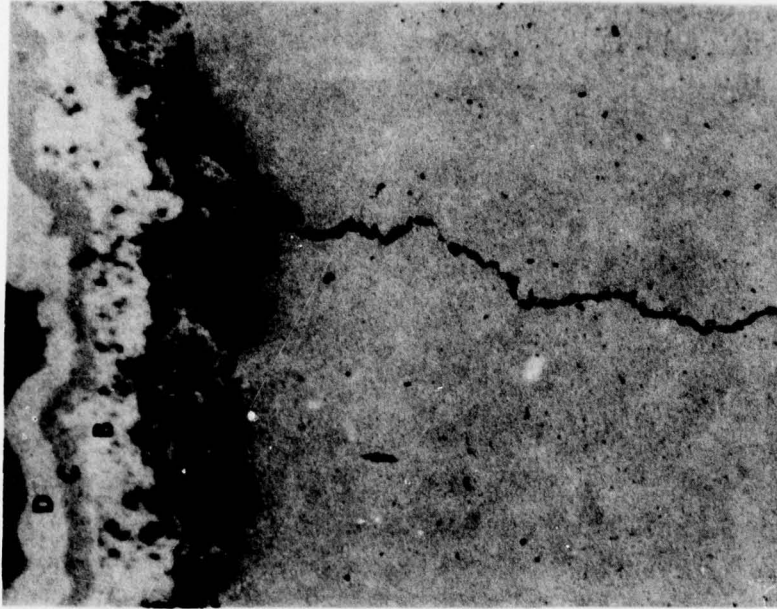

MAG: 500X

Figure 25. Dovetail Crack in a Ti-6Al-4V Alloy Compressor Disk Test Sample Bridged by Vacuum Plasma Spraying Pure Titanium (A), Pure Copper (B) and Followed by a Layer of Nickel (C) and a Layer of Copper (D) to Aid in Metallographic Sample Preparation.



UNETCHED      MAG: 200X

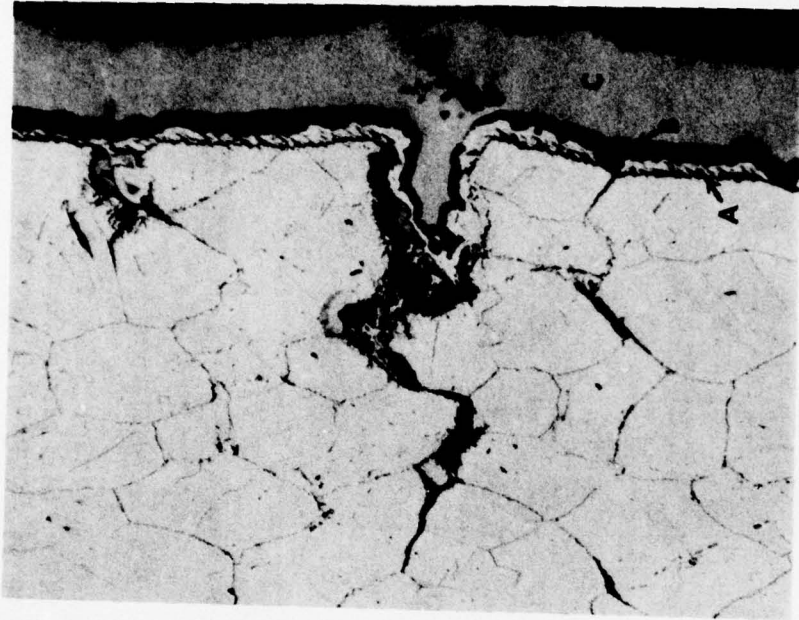

KALLINGS ETCH      MAG: 200X

Figure 26. Cracks in Waspaloy Stress-Rupture Bar Cleaned and Bridged by Ion Plating Techniques. Ion-Plated Pure Nickel (A) followed by a Flash of Copper (B) and Electroless Nickel (C). (B) and (C) Used as Sample Preparation Aids.

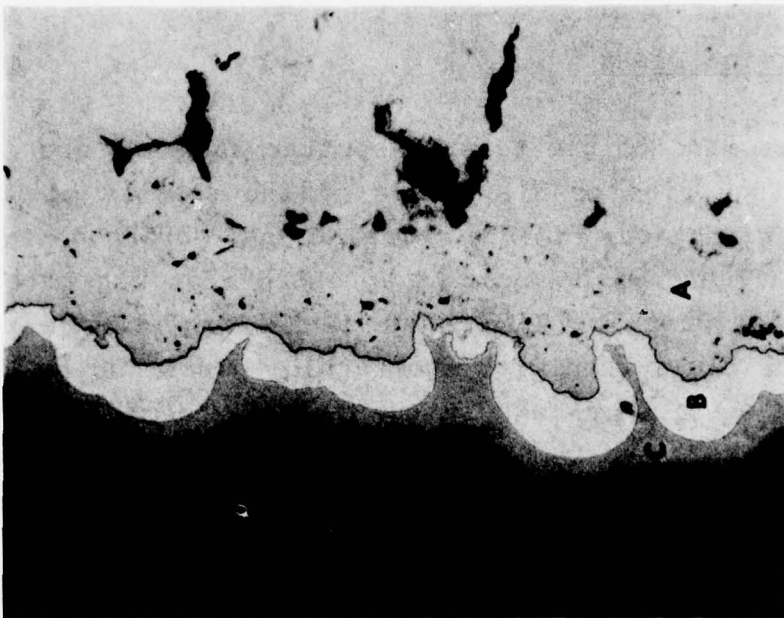

UNETCHED      MAG: 200X

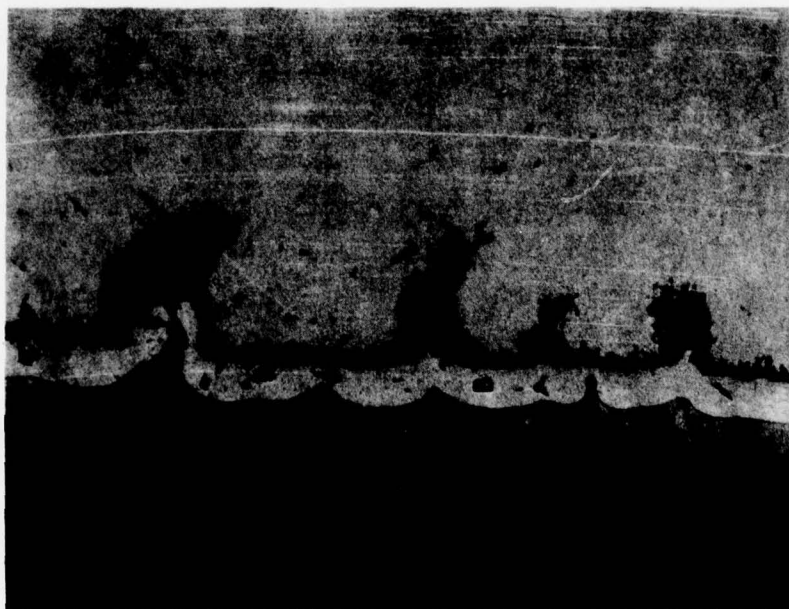

UNETCHED      MAG: 200X

Figure 27. Surface of Waspaloy Stress-Rupture Test Bar Before (Left) and After Grit Blasting, Transferred-Arc Cleaning and Vacuum Plasma Spraying of Nickel A (Right). Copper B and Nickel C are for Metallographic Sample Preparation.

nickel. As in the case of ion plating, the surface appeared clean, but the cracks remained oxidized.

#### 2.2.2.2 Field-Service Disks

A decision was made to use reverse-sputter cleaning and ion plating for bridging prior to HIP, based on the results of the metallographic examination of the cleaned and bridged test samples of Ti-6Al-4V and Waspaloy. It appeared that the probability of success of crack bridging and HIP healing was greater with the compressor disks than with the turbine disks due to the inability to clean oxidized cracks in the Waspaloy disks.

The Ti-6Al-4V alloy compressor disks were ion plated with a 0.001- to 0.002-inch thick layer of pure titanium followed by a 0.001-inch thick layer of copper on the blade attachment dovetails of five field-service compressor disks. Reverse sputtering was employed prior to plating to clean the surfaces. The work was accomplished at Koral Laboratories, St. Paul, Minnesota. Figure 28 shows the five compressor disks after bridging. The light-colored regions encompassing the dovetails and part of the web are the copper plate which was applied over the layer of pure titanium. Additional copper was subsequently electroplated over the flash of copper shown here prior to shipment for HIP.

Six Waspaloy turbine disks and disk sections were ion plated with approximately 0.002-inch of pure nickel at Koral Laboratories. The disks and disk sections are shown in Figure 29. Additional nickel (0.003 to 0.005 inch) was electroplated over the ion plate layer to build up the bridge over the fatigue cracks.

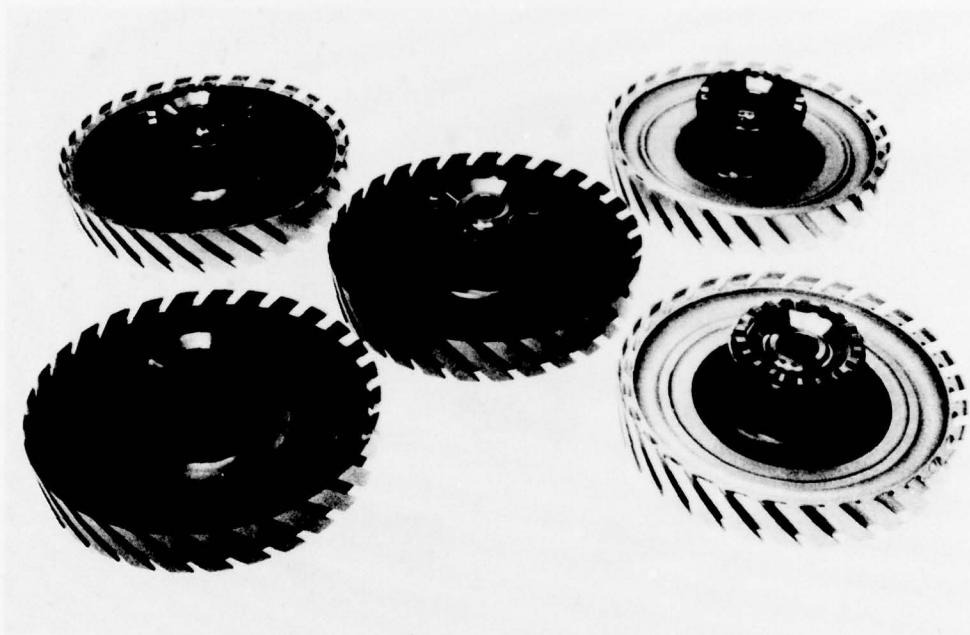

Figure 28. Five TSCP700 Compressor Disks Which Have Been Reverse-Sputter Cleaned and Ion Plated with Pure Titanium Followed by a Flash of Copper. MAG:  $\sim 0.3X$ .



Figure 29. Turbine Disks and Disk Sections Ion Plated with Pure Nickel Prior to HIP.

### 2.3 Task III - Hot Isostatic Pressing (HIP)

HIP of the cleaned and bridged compressor disks and the turbine disks was performed (separately) at Industrial Materials Technology, Woburn, Massachusetts. The Ti-6Al-4V compressor disks were packed in titanium clips (oil-free stamping scrap) to prevent oxidation, and the Waspaloy turbine disks were double wrapped in stainless steel foil to act as an oxygen getter. New argon gas was used for each run to minimize the possibility of contamination from previous runs. Each disk was supported to minimize distortion and undue loads from other disks. Heat treatments, subsequent to HIP, were performed on the Waspaloy turbine disks to restore mechanical properties that were deteriorated during slow cooling from the maximum HIP temperature.

#### 2.3.1 Ti-6Al-4V Compressor Disks

HIP cycles for Ti-6Al-4V alloy were previously developed under both government and private investigations. The temperature range utilized has been from 1550°F to 1750°F, with 1650°F the most commonly used. At 1550°F, the defect closure is slow, and the time for diffusion bonding is increased. At 1750°F, the strict maintenance of disk dimensions would be difficult due to distortion, and the beta transus of the Ti-6Al-4V alloy is approached, leading to possible metallurgical changes during HIP processing. Pressures from 10 to 15 ksi for periods of two to four hours had been used. It was thought that 1650°F would have a high probability of success without causing undue dimensional changes in the finished disks. However, the Battelle investigation<sup>1</sup> on rejuvenation of fatigue-test samples of Ti-6Al-4V recommends HIP temperatures below 1600°F to minimize microstructural coarsening. To determine the effect of the HIP thermal treatment on AiResearch compressor disks, samples from a field-service disk were exposed for four hours at 1550°F, 1650°F,

and 1750°F and examined metallographically. Figures 30 and 31 show the resulting etched microstructures at 200X and 500X magnifications, respectively. It appears that 1550°F shows the least change from the original microstructure, thus confirming the Battelle results. Based on these results and on the assumption that a lower exposure temperature should minimize dimensional changes in the finished hardware, the HIP temperature chosen was 1550°F with the pressure and hold time set at 15 ksi and four hours, respectively.

The compressor disks and disk sections were HIPped as one lot at Industrial Materials Technology (I.M.T.) Woburn, Massachusetts. New gas was used with the measured contamination levels shown in Table 14. The parts were packed in titanium clips to reduce the potential for oxygen contamination on the surfaces. The parts were also supported on ring-shaped tooling to prevent contact with each other and to minimize dimensional changes (refer to sketch in Figure 32). Figure 33 shows the HIP load upon removal from the autoclave. The not-bridged disks are clean and on the bridged disks, the copper electroplate is blistered in regions that were not previously ion plated.

#### 2.3.1.1 Ti-6Al-4V Compressor Disk Heat Treatment

One compressor disk, designated for metallurgical evaluation, was sectioned and room-temperature tensile properties were determined in the as-HIPped condition. Table 15 shows the values obtained compared to AiResearch Specification minimums. The properties were within the acceptable range for mill-annealed Ti-6Al-4V, and it was deemed unnecessary to repeat the solution and age heat-treat cycle on the disks, since they are normally used in the mill-annealed condition.

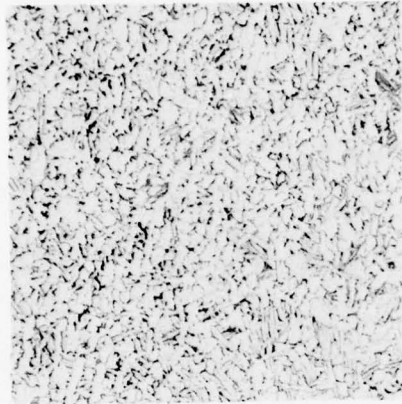

ORIGINAL DISK

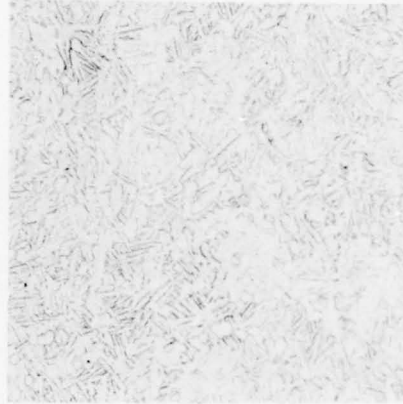

1550°F

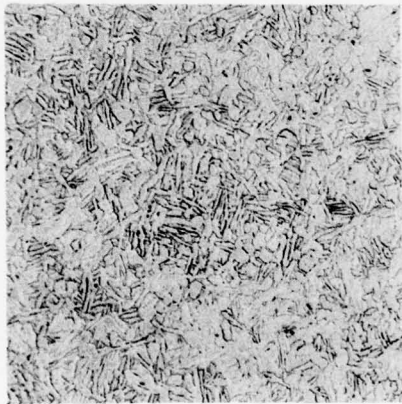

1650°F



1750°F

Figure 30. Effect on Microstructure of Ti-6Al-4V of Four-Hour Exposure at Temperatures Indicated. Etchant: HF-HNO<sub>3</sub> MAG: 200X

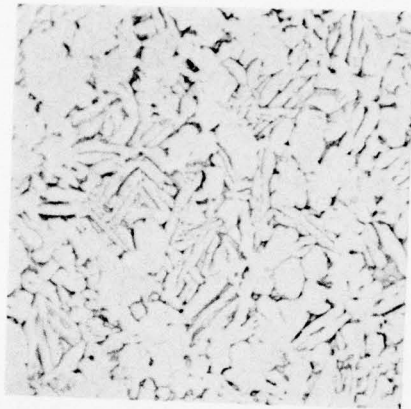

ORIGINAL DISK

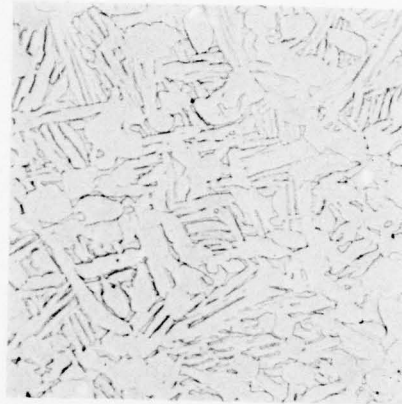

1550°F



1650°F

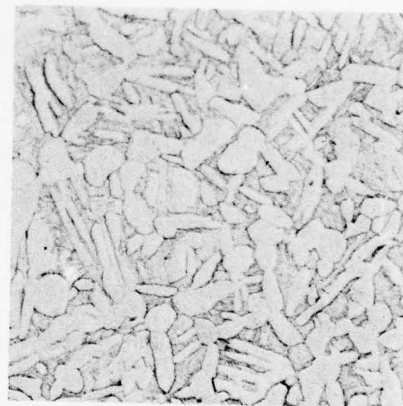

1750°F

Figure 31. Effect on Microstructure of Ti-6Al-4V, Four-Hour Exposure at Temperatures Indicated. Etchant: HF-HNO<sub>3</sub> MAG: 500X.

TABLE 14. PURITY OF ARGON GAS USED FOR HIP OF  
Ti-6Al-4V ALLOY COMPRESSOR DISKS.

Argon Gas Analysis, Parts Per Million

<u>Gas</u>	<u>Inlet</u>	<u>Outlet</u>
O <sub>2</sub>	4	1.1
H <sub>2</sub> O	10.4	6.3
H <sub>2</sub>	9.6	24.3
THC*	ND**	5.0
CO	ND	7.4
CH <sub>4</sub>	ND	4.6
CO <sub>2</sub>	2.0	3.0
N <sub>2</sub>	ND	ND
Argon	Balance	Balance

\*THC = Total hydrocarbons (analyzed as methane)

\*\*ND = None detected

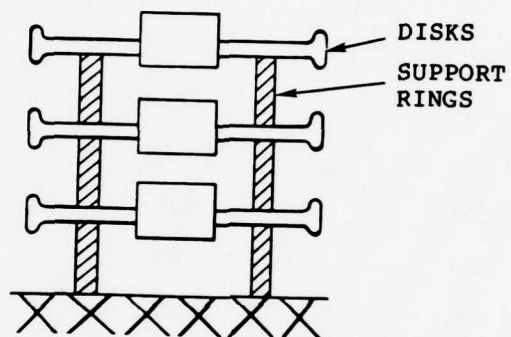

Figure 32. Loading Arrangement of Compressor Disk in HIP Autoclave Showing Rig Support Tooling.

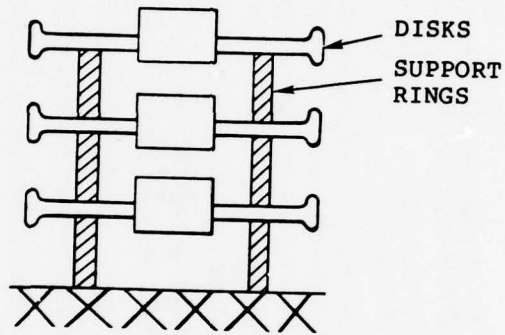

Figure 32. Loading Arrangement of Compressor Disk in HIP Autoclave Showing Rig Support Tooling.



Figure 33. Ti-6Al-4V Alloy Compressor Disks  
(And Sections) After HIP.

TABLE 15. AS-HIPPED ROOM-TEMPERATURE TENSILE PROPERTIES FROM Ti-6Al-4V ALLOY DISK.

Sample No.	0.2 Percent Y.S. (ksi)	UTS (ksi)	Percent Elongation	Percent Reduction Of Area
1	127.3	136.4	21.5	48.0
2	128.0	137.8	17.6	48.0
3	127.6	137.5	17.1	46.5
AiResearch Spec and AMS4928 Minimums	120.0	130.0	10.0	25.0

### 2.3.2 Waspaloy Turbine Disks

The HIP cycle for Waspaloy required detailed consideration, because if the normal solution heat-treatment temperature range of 1800°F to 1850°F is exceeded during HIP, the grain size would be increased with a reduction in mechanical properties. In contrast, at 1800° to 1850°F, diffusion bonding to heal cracks in a reasonable length of time probably would not be effective due to the high flow stress of the alloy at these temperatures. A literature survey made prior to this study revealed little work had been done in the area of diffusion bonding of gamma-prime-forming nickel-base alloys with no filler metal present. Therefore, a diffusion-bonding study was required to assess the effects of time, temperature, and pressure on the microstructure, grain size, and bond strength of Waspaloy components to be HIPped.

Half-inch diameter Waspaloy test specimens were prepared for bonding, as shown in Table 16. The lapped and cleaned surfaces were then brought into contact and strips of INCO-600 foil were tack welded to the outside surface of the specimens to assure proper alignment in the test fixture. Figure 34 shows the test specimen/tooling arrangement within the vacuum chamber. A water-cooled hydraulic ram transmitted the required compressive load through the tooling to the induction-heated bond specimen. Figure 35 shows the induction coil in place together with the graphite susceptors which surrounded the specimens to promote temperature uniformity. The outer susceptor was wrapped in a layer of insulating ceramic to prevent heat losses to the chamber walls. A vacuum level of  $10^{-5}$  to  $10^{-7}$  Torr was maintained throughout the bond cycle and a heating rate of 12 to 15°F/minute was observed. Temperature was monitored both optically and with thermocouples.

TABLE 16. WASPALOY SURFACE PREPARATION.

o Machining

Grind ends flat and parallel to within 0.002 inch.  
Lap to 6-8 AA

o Cleaning

Vapor degrease  
Alkaline clean (2-5 min)  
Cold water rinse  
HCL pickle (2-3 min)  
Cold water rinse  
Distilled/deionized water rinse  
Dry

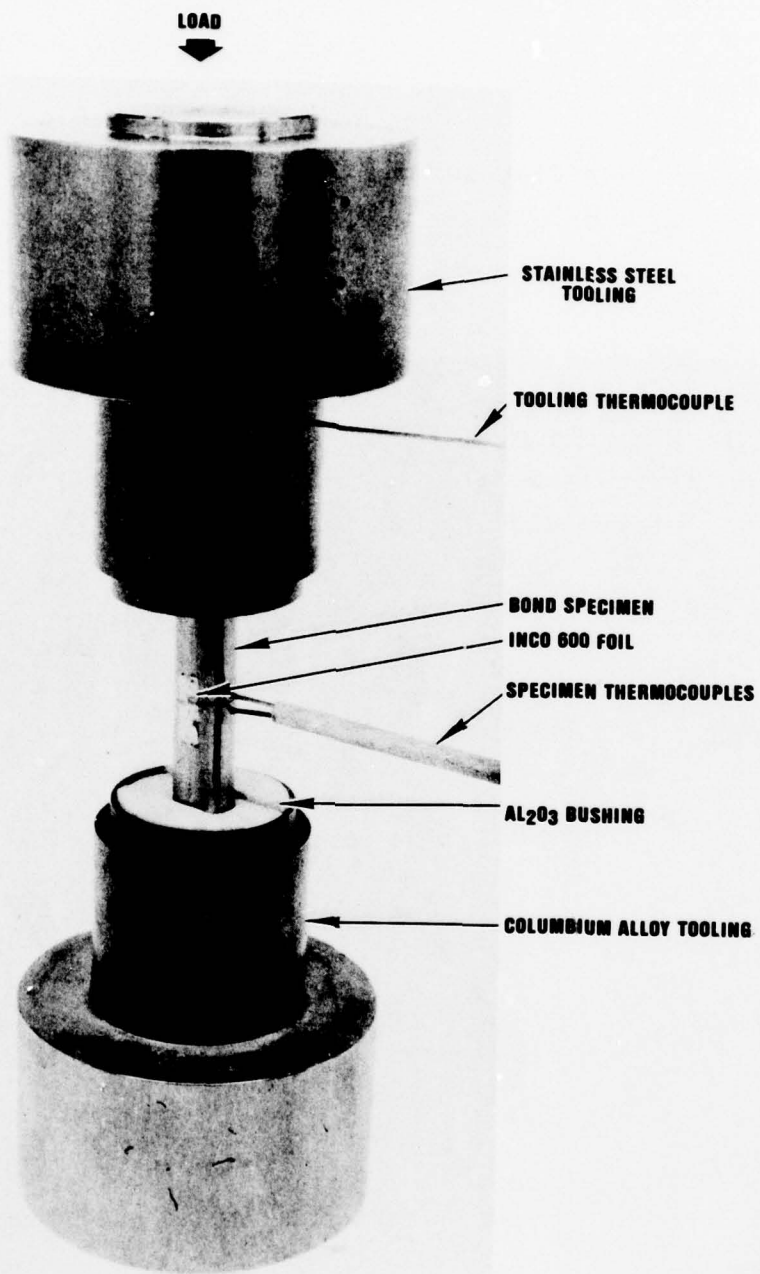

Figure 34. Test Specimen/Tooling Arrangement.



Figure 35. View Inside Chamber Showing Induction Coil and Susceptors. Top Tooling Removed.

Problems encountered with the induction heating and vacuum systems reduced the number of tests initially planned, although meaningful data was generated with a series of five successful runs. A bond cycle of 1800°F/4 hours/15 ksi yielded the best microstructural and mechanical properties. Table 17 shows the bonding parameters for each run and the 1000°F tensile properties of 0.070-inch gauge-diameter test specimens removed from the bonded samples. Bond specimens given the above cycle exhibited an average yield strength of 115.9 ksi compared to 116.5 ksi for the baseline unbonded specimens. Ultimate strength and elongation are lower for the bonded specimen compared to the baseline indicating less than optimum bonding was produced.

At bonding temperatures above 1800°F, grain growth was observed which contributed to the reduced strength of samples bonded under these conditions. Figure 36 is a photomicrograph showing the increase in grain size exhibited by the 1900°F/4-hours/5-ksi specimens over those bonded at 1800°F. The latter specimens experienced essentially no grain growth.

The apparent reason for the observed decrease in ductility of the bonded specimens, versus the baseline unbonded specimens, was the presence of a continuous oxide film at the bond interface (refer to Figure 37). Scanning-Electron-Microscope (SEM) analysis of the film revealed it to be high in aluminum and titanium. Another feature of the bond area was the presence of a narrow band of recrystallized grains denuded of gamma prime. This apparently resulted from the cold work introduced during the grinding and lapping of the bond specimen surfaces prior to joining, and should not occur in cracked and rejuvenated hardware.

The depletion of gamma prime in the grains adjacent to the bond line indicated that aluminum and titanium in this area reacted with available oxygen to form the observed oxide interlayer. Since a high vacuum was maintained during the bond cycle,

TABLE 17. BONDING PARAMETERS AND TENSILE DATA FOR WASPALOY CYLINDERS.\*

Bonding Parameters**				1000°F Tensile Data				
Bond Run	Temp (°F)	Time (hr)	Stress (ksi)	Test Bar	UTS (ksi)	0.2% YS (ksi)	% EL	% RA
1	1950	1/2	7.6	1-1	Lost during machining			
2	1800	2	28	2-1	Lost during machining			
3	1800	4	15	3-1	96.1	--	1.7	3.6
	1800	4	15	3-2	124.2	119.5	1.6	4.0
4	1800	4	15	4-1	115.8	111.7	1.1	2.8
	1800	4	15	4-2	122.8	116.6	1.7	3.9
	1800	4	15	4-3	Lost during set up			
5	1900	4	5	5-1	101.8	100.8	2.0	5.9
				5-2	95.9	95.9	1.1	4.3
Baseline specimens (no bond)				6-1	162.6	117.8	21.7	34.2
				6-2	162.7	114.6	24.0	36.8
				6-3	162.7	117.1	24.5	36.8
AirResearch material specification minimums					160.0	110.0	12.0	15.0

\*All specimens were given the following heat treatment: 1850°F (4 hrs)  
1550°F (4 hrs)  
1400°F (16 hrs)

\*\*Vacuum:  $10^{-5}$  -  $10^{-7}$  Torr

Heating rate 12 - 15°F/min

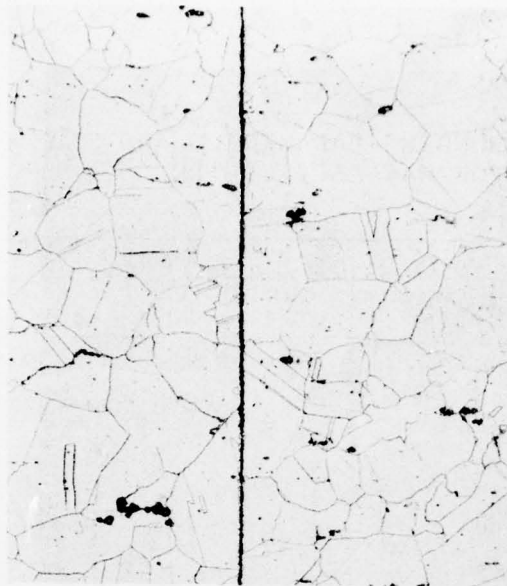

RUN #4 - 1800°F/4 Hr/15 Ksi

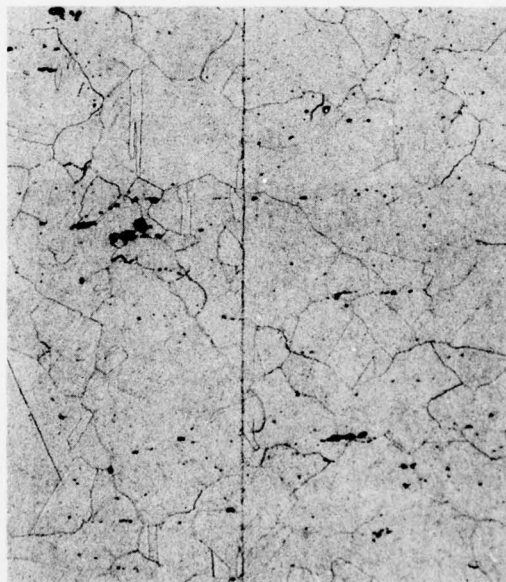

RUN #5 - 1900°F/4 Hr/5 Ksi

Figure 36. Photomicrographs Showing Grain Growth Experienced by 1900°F/4-hr/5-ksi Bond Specimen (After Heat Treatment).

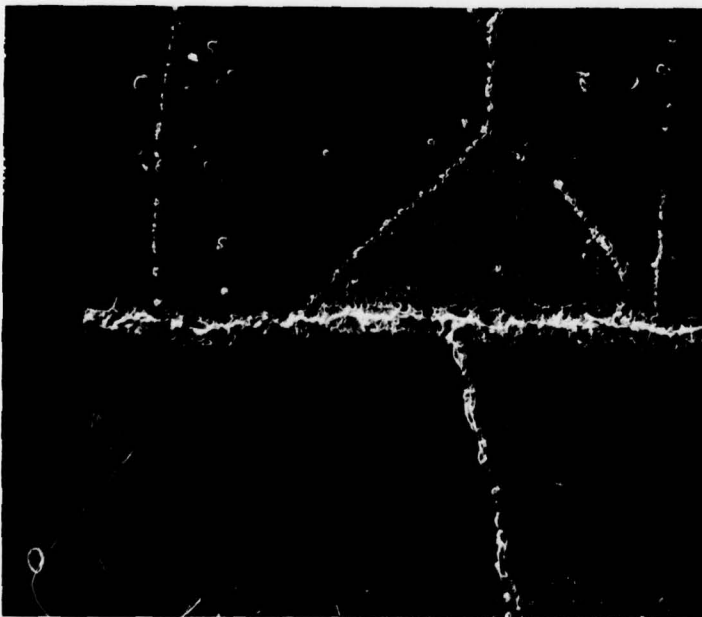

1000X

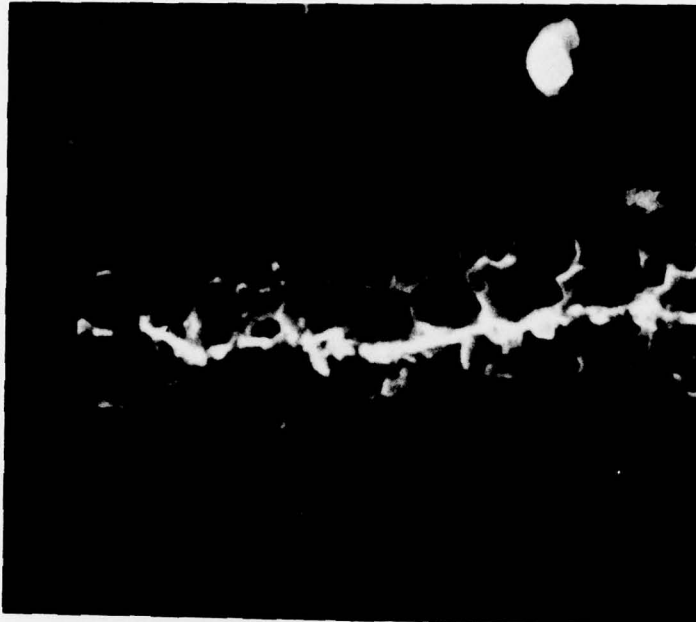

5000X

Figure 37. SEM Photomicrographs of Typical Bond Joint Showing Aluminum/Titanium Oxide Interlayer. Note Recrystallization Adjacent to Bond.

the problem appears to be related to the surface preparation process and the low free energy of formation of aluminum and titanium oxides.

The high yield strength and stable grain structure of the samples processed with the 1800°F/4-hour/15-ksi cycle made this the first choice for HIP of the Waspaloy turbine disks. The relatively low temperature was also desirable so that dimensional changes would be kept to a minimum.

The contents of the load of Waspaloy turbine disks and disk sections HIPped at Industrial Materials Technology are shown in Figure 38. The HIP parameters were 1800°F ±25°F for four hours and at 15,000 psi argon. New argon gas was used and the measured inlet and outlet contamination levels are shown in Table 18. The parts were double wrapped in stainless-steel foil to minimize contamination, and were supported on ring-shaped tooling to prevent contact with each other and with the vessel walls.

#### 2.3.2.1 Waspaloy Turbine Disk Heat Treatment

The HIPped Waspaloy turbine disks and disk sections were vacuum heat treated with the following cycle:

- o Solution: 1850°F ±25°F, 4 hours, argon gas fan quench
- o Stabilize: 1550°F ±25°F, 4 hours, argon gas fan quench
- o Age: 1400°F ±25°F, 16 hours, argon gas cool

The disks were supported on ring tooling to minimize distortion throughout the process.

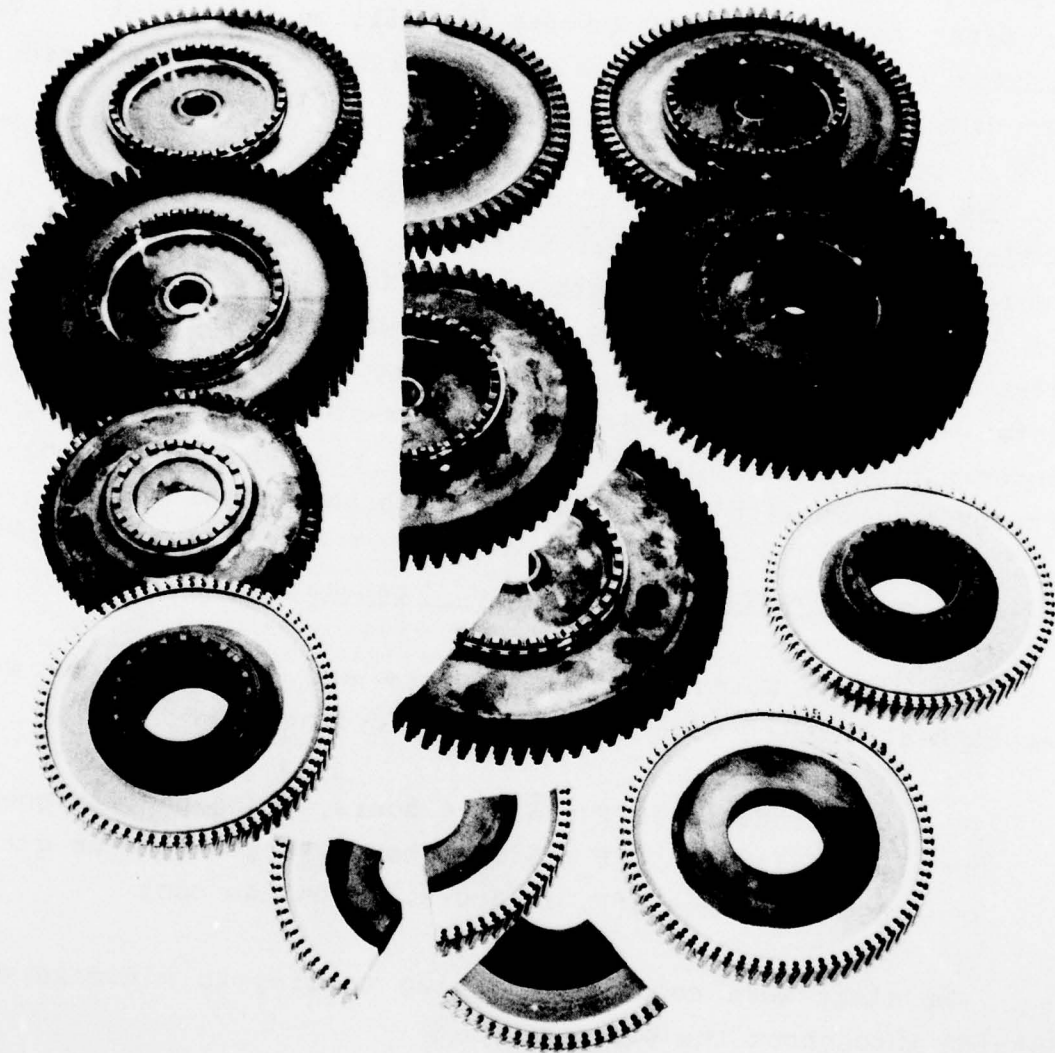

Figure 38. As-HIPped Waspaloy Disks and Disk Sections.

TABLE 18. PURITY OF ARGON GAS USED FOR  
HIP OF WASPALLOY TURBINE DISKS.

Argon Gas Analysis,  
Parts Per Million

<u>Gas</u>	<u>Inlet</u>	<u>Outlet</u>
O <sub>2</sub>	0.3	2.3
H <sub>2</sub> O	3.6	3.6
H <sub>2</sub>	16.4	1.3
THC*	ND**	0.1
CO	ND	6.4
CH <sub>4</sub>	ND	0.1
CO <sub>2</sub>	ND	5.1
N <sub>2</sub>	ND	ND
Argon	Balance	Balance

\* THC = Total hydrocarbons (analyzed as methane)

\*\* ND = None detected

## 2.4 Task IV - Post-HIP Examination

### 2.4.1 Nondestructive Evaluation

#### 2.4.1.1 Ti 6Al-4V Compressor Disks

Eight of the nine HIPped whole Ti-6Al-4V alloy compressor disks were subjected to nondestructive inspection including visual, eddy current, and fluorescent penetrant. The four disks (of the eight), which had been bridged, had the copper layer stripped using nitric acid prior to inspection. The ninth whole disk, which had also been bridged, was sectioned for metallurgical examination with all layers of plating remaining and will be discussed in Section 2.4.3 1.

The eddy-current evaluation of the blade dovetails showed that the readings of the post-HIP crack depths essentially remained unchanged when compared to the pre-HIP crack depths. The large crack indications documented before HIP still tended to show up as large crack indications after HIP. The disks were also subjected to fluorescent-penetrant inspection. Only one crack was found, and had been noted from visual inspections both before and after HIP. Fluorescent penetrants had not been successful in the initial inspection in detecting dovetail cracks, since these cracks are extremely tight.

A pitting-type corrosion was noted in regions that had been electroplated with copper but had not been first ion plated. Figure 39 shows this corrosion in the region of the curvic coupling. The possibility exists that electroplating solution was trapped between the disk surface and the heavy copper plate due to poor adherence, and upon heating, corrosion of the Ti-6Al-4V occurred.

AD-A078 593

AIRESEARCH MFG CO OF ARIZONA PHOENIX  
HOT ISOSTATIC PRESSING REJUVENATION OF DISKS.(U)  
JUL 79 D V SUNDBERG , D H COMEY

F/6 13/8

UNCLASSIFIED

21-3238

AFML-TR-79-4093

F33615-77-C-5113

NL

2 OF 2

AD  
A 078593

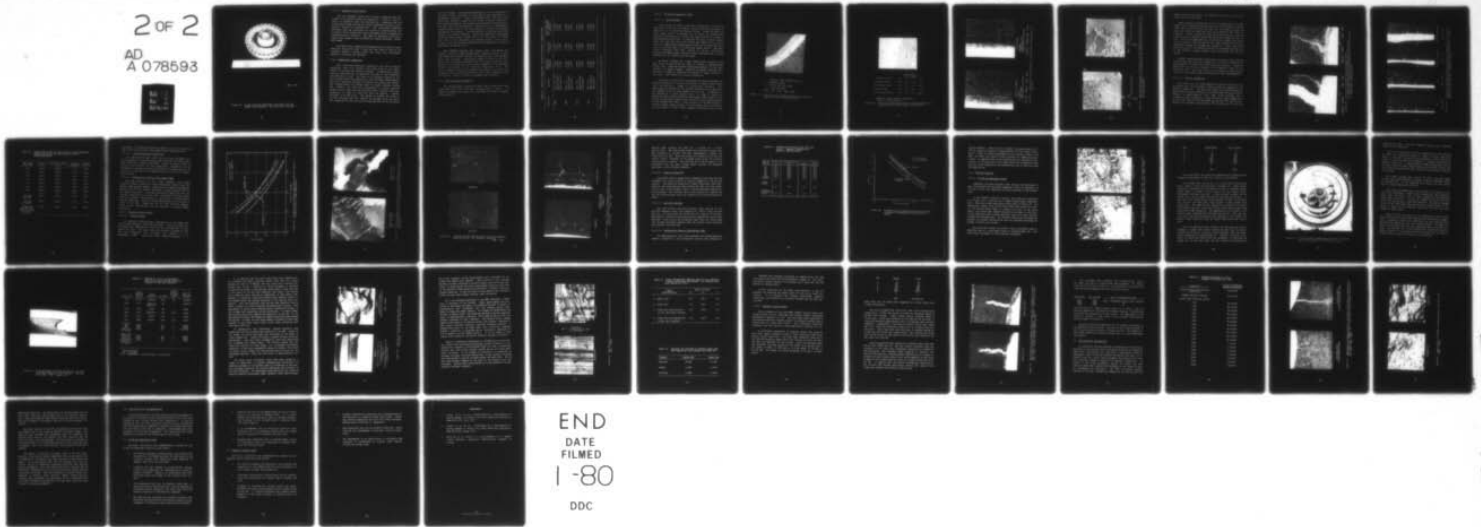

END  
DATE  
FILMED  
1-80  
DDC

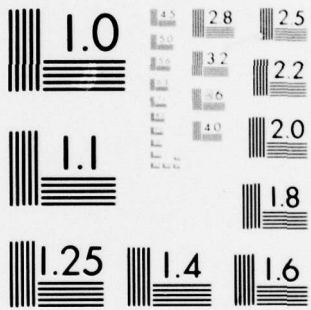

MICROCOPY RESOLUTION TEST CHART  
NATIONAL BUREAU OF STANDARDS-1963-A

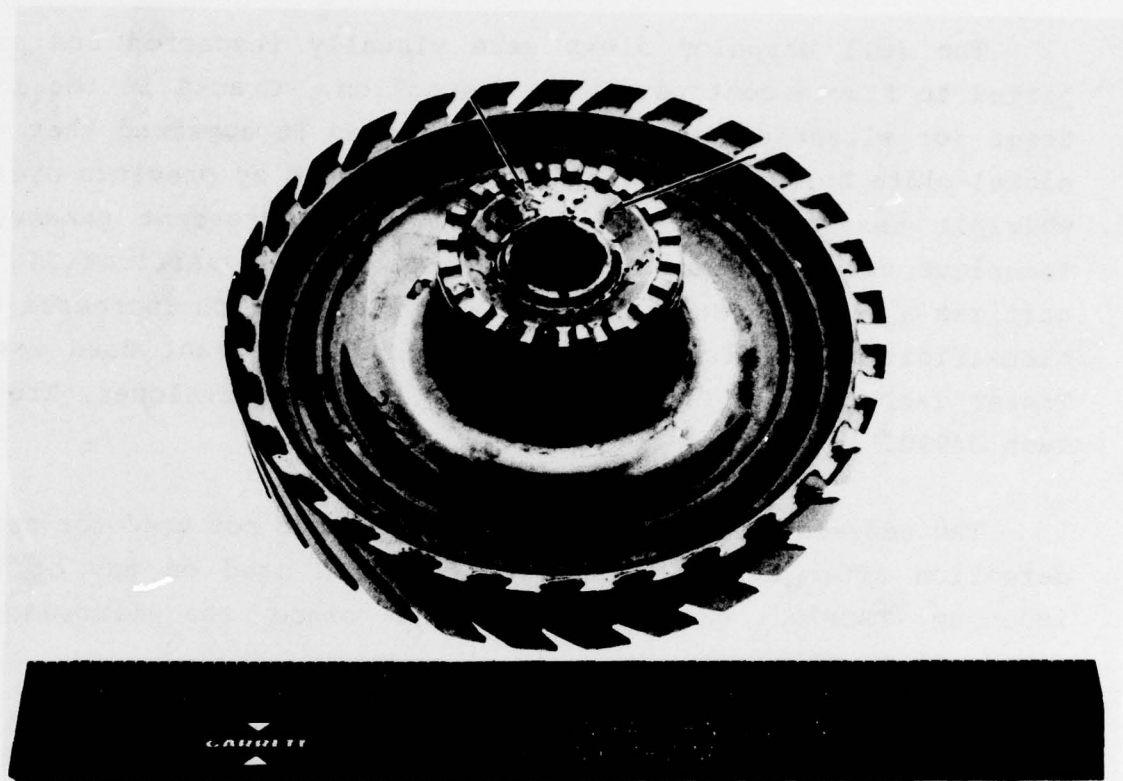

MAG: 1/2X

Figure 39. Ti-6Al-4V Alloy Compressor Disk After HIP and Copper Plate Removal. Note Corrosion (arrows).

#### 2.4.1.2 Waspaloy Turbine Disks

The full Waspaloy disks were visually inspected and subjected to fluorescent penetrant inspection. Cracks in the fir-trees (or elsewhere) were not observed, and it appeared that the nickel-plate bridge covered the cracks induced by previous cyclic whirlpit testing or field-service. The fluorescent penetrant technique used was equivalent to a Group VI classification but utilizes a Group V penetrant plus a developer which increases the classification to Group VI. The specific penetrant used was a Tracer Tech Shannon P133A followed by a spray developer, Tracer Tech D499C.

The eddy-current inspection technique was not used for crack detection after HIP since it had not been used on any of the incoming TSCP700 turbine disks, and since the fluorescent penetrant technique was adequate.

#### 2.4.2 Dimensional Inspection

After fluorescent-penetrant inspection, the eight Ti-6Al-4V compressor disks were cleaned using glass beads at low impact speeds to minimize any material removal. A dimensional inspection was performed and a comparison was made to the dimensions obtained prior to HIP. The layer of ion plated titanium on the four bridged disks was detected in disk thickness measurements. The curvic couplings (method of transmitting torque) were acceptable dimensionally but showed signs of slight movement during HIP. However, the disks were unacceptable in runout measured between the OD faces and the locating curvic coupling with discrepancies as large as 0.048 inch from the nominal. (Normal tolerance is  $\pm 0.003$  inch). The method of loading the disks in the HIP autoclave does not explain the warpage since the parts were supported so that the curvic couplings and the OD rim would

not be stressed. One possible explanation is the relaxation of residual stresses produced in the original disk manufacture or developed in-service. (This first-stage disk runs less than 300°F and, therefore, would not be stress relieved in-service). Mill-annealed material can contain high residual stresses due to the fact that the processing is carried out at a temperature (1300°F-1350°F) that is not high enough to relieve the stresses induced by hot working. Inconsistencies in cooling could also account for residual stresses. While the observed disk warpages would preclude further engine service for the parts, the disks were able to be rebalanced and fatigue tested in the cyclic whirlpit with the existing dimensional discrepancies, as will be discussed in Section 2.4.4.

Four GTCP660 Waspaloy APU turbine disks (P/N 892812 and 892813), which had been dimensionally inspected prior to HIP, were glass bead cleaned and were re-inspected after HIP and again after heat treatment. Dimensional changes occurred on all four disks that would make them unsuitable for further engine service. However, the changes were slight when compared to the movement observed previously in the Ti-6Al-4V compressor disks. The curvic couplings (method of transmitting torque) were out of tolerance, as well as the parallelism of the curvic coupling to the OD rim face. Table 19 lists the changes that occurred.

#### 2.4.3 Metallurgical Evaluation

The metallurgical evaluation after HIP utilized the half disks from each alloy that were characterized in Task I. In addition, HIPped full disks were sectioned and used as supplemental material.

TABLE 19. POST-HIP DIMENSIONAL ANALYSIS ON WASPALOY TURBINE DISKS.

Serial No.	Location	Blueprint Dimension (inches)	Before HIP (inches)	After HIP and Heat Treatment (inches)
2425	Ref. O.D. C <sup>(1)</sup>	11.202	11.202	11.2025
	Radial Runout A	0.0006	0.0012	0.0011
	Face Runout B	0.0004	0.0010	0.0021
1190	Ref. O.D.	10.488	10.489	10.487
	Radial Runout	0.0006	0.0003	0.0012
	Face Runout	0.0004	0.0001	0.0013
2370	Ref. O.D.	10.488	10.536	10.533
	Radial Runout	0.0006	0.0004	0.0016
	Face Runout	0.0004	0.0002	0.0016
1316	Ref. O.D.	10.488	10.484	10.481
	Radial Runout	0.0006	0.0004	0.0019
	Face Runout	0.0004	0.0004	0.0035

(1) Designates location of dimensions in Figure 10.

### 2.4.3.1 Ti-6Al-4V Compressor Disks

#### 2.4.3.1.1 Metallography

Disk Serial No. 4829, which was bridged prior to HIP, was sectioned for tensile bar removal (results reported previously in Section 2.3.1.1) and microstructure study. Figure 40 shows the acute angle corner of dovetail No. 16 which, by eddy-current analysis techniques prior to HIP, was found cracked to a depth of approximately 0.020 inch. A crack did not exist in that location after HIP and must have been closed and bonded during rejuvenation. Eddy-current measurements could not be taken after HIP due to the heavy layer of titanium and copper plates. Two additional dovetails that were cracked in service (previously detected by eddy-current analysis) were sectioned and, as with dovetail No. 16, cracks were not found.

As shown in Figure 40, a dark etching layer existed in the base alloy of disk Serial No. 4829 to a depth of approximately 0.0015 inch. Scanning electron microscope analysis of the layer showed it to contain copper. Electron microprobe analyses were performed at AFML to determine the amount of copper present in the layer. The results are given in Figure 41.

The layer was identified, using TEM thin-film techniques, as stabilized beta with a fine distribution of small alpha and/or  $Ti_2Cu$  precipitates. Copper is a strong beta stabilizer. This beta layer was present on the internal surfaces of the dovetails but changed on the outside diameter of the disk. It appeared to be replaced by a white etching layer, as shown in Figure 42. Figure 43 shows Scanning Electron Microscope (SEM) images of the corner of a dovetail showing this transition from stabilized beta to the unidentified layer. X-ray analysis in the SEM detected a slightly higher copper content in the OD layer than in the beta, but was unable to detect other chemical differences due to the

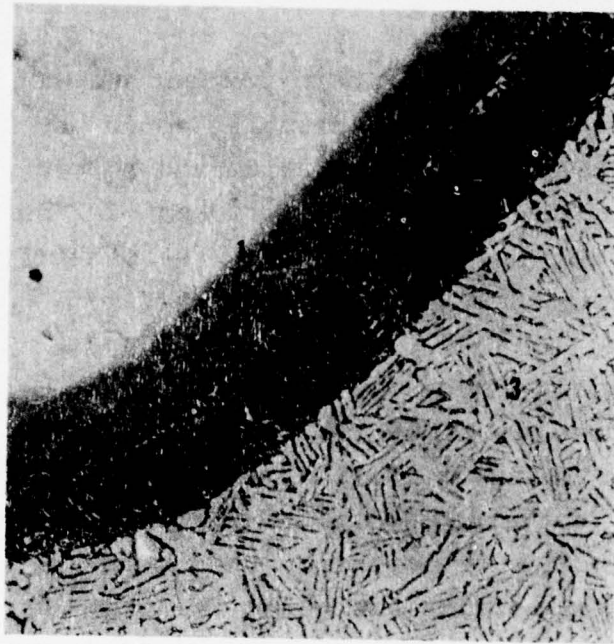

DISK NO. 4829 DOVETAIL NO. 16

1 - BRIDGED LAYERS

2 - STABILIZED BETA PHASE

3 - Ti-6Al-4V DISK

ETCH: HF - HNO<sub>3</sub> MAG: 400X

Figure 40. Microstructure of HIP Rejuvenated Ti-6Al-4V Compressor Disk Dovetail Corner.

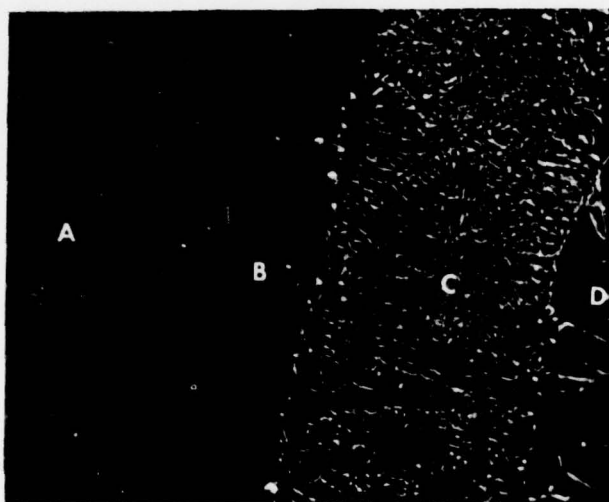

Analysis Point	Approximate Wt Percent*			
	Cu	V	Al	Ti
A Copper Plate	99.4	0.0	0.3	1.1
B Titanium Plate	62.5	0.5	0.2	33.9
C Beta Phase	13.6	4.2	4.9	73.5
D Ti-6Al-4V Matrix	0.0	1.9	6.1	88.4

\*Element totals do not necessarily  
add up to 100 percent.

Figure 41. Electron Microprobe Chemical Analysis Results of  
Stabilized Beta Phase Layer in Ti-6Al-4V.

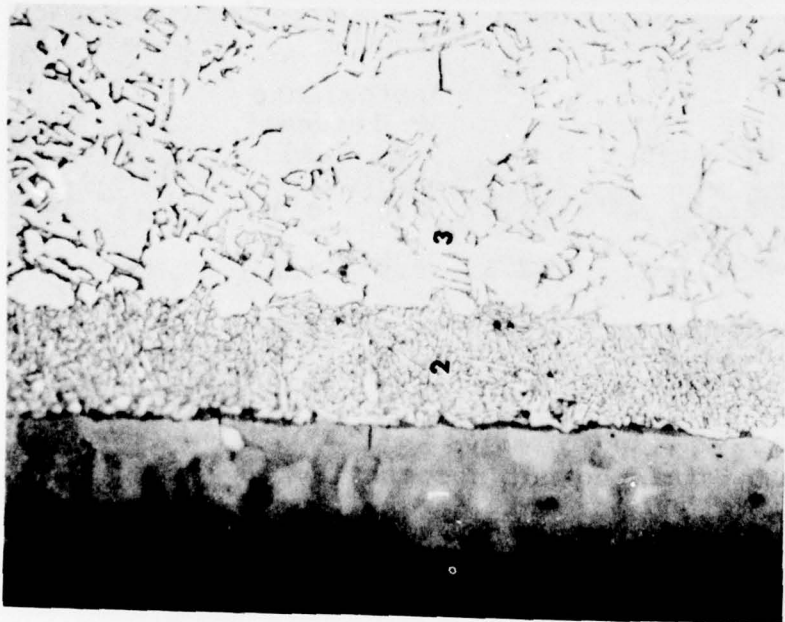

BASE OF DOVETAIL

- 1 BRIDGE
- 2 BETA LAYER
- 3 BASE ALLOY Ti-6Al-4V

ETCHANT: KROLLS MAG: 500X

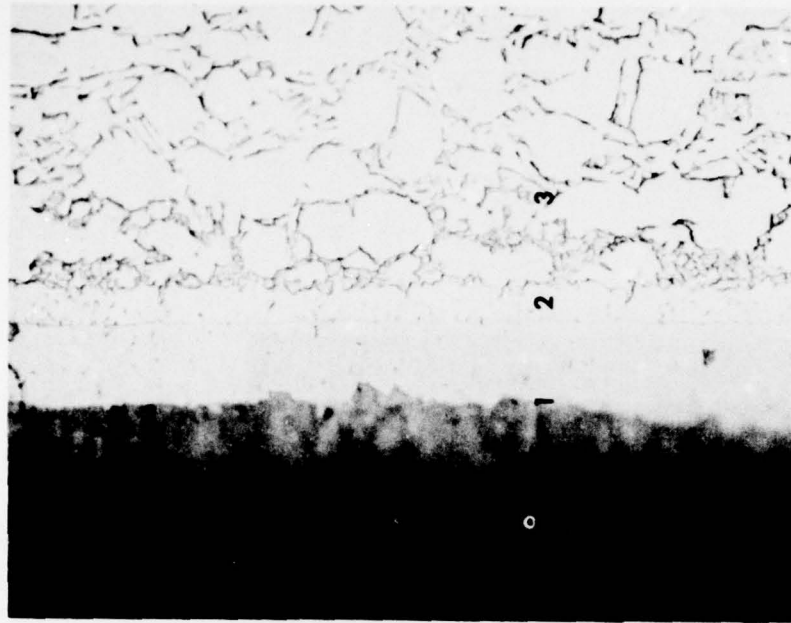

OD OF DISK

- 1 BRIDGE
- 2 UNKNOWN LAYER
- 3 BASE ALLOY Ti-6Al-4V

ETCHANT: KROLLS MAG: 500X

Figure 42. Surfaces of Disk S/N 1706 at the OD and at the Base of the Dovetail.

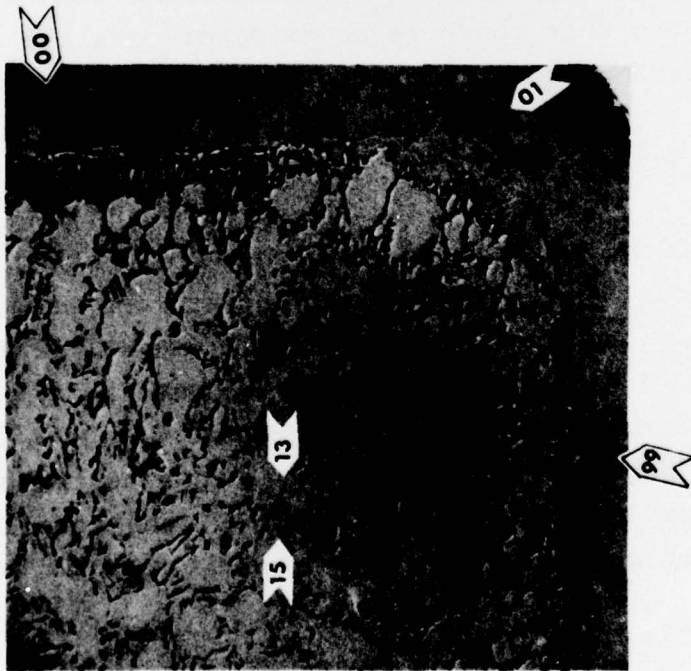

Mag.: 500X

Side of Dovetail

OD

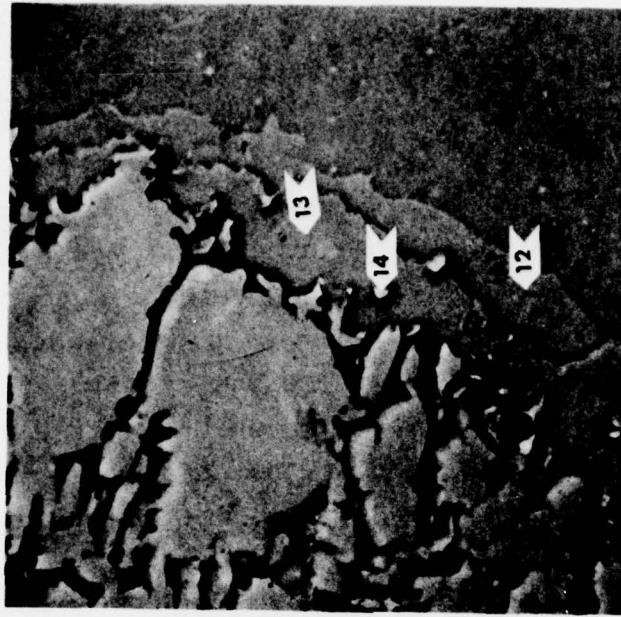

Mag.: 2000X

Side of Dovetail

OD

Figure 43. SEM Photomicrographs of OD Dovetail Corner Showing Stabilized Beta on the Side and the Absence of the Beta Layer on the OD (Arrows Indicate Positions of X-Ray Analyses).

capabilities of the system. An explanation for this loss of beta layer was not formulated.

Metallographic evaluations of both bridged and non-bridged HIPped disks indicated that the majority of the dovetail fatigue cracks were healed during HIP, when the ion plating bridge was used, and cracks in disks that were not bridged did not close (as expected). Figure 44 shows a large crack that was not closed by bridging and an adjacent crack that had been bridged but did not heal. Note the bridge material (titanium plus copper) was forced into the smaller crack during HIP but crack closure did not occur (probably because the bridge was ruptured). These cracks had been visible prior to bridging and did not represent the majority of the dovetail fatigue cracks, which are tight and are not visible.

Careful metallographic examination was given to the surface of the disks that were not bridged prior to HIP to determine if contamination or stabilized alpha case had occurred. Figure 45 shows both the OD and a portion of the dovetail base of disk Serial No. 4774. Note that there is no evidence of alpha case or visible surface deterioration indicating an inert HIP atmosphere.

#### 2.4.3.1.2 Tensile Properties

The results of the room-temperature tensile testing of the Ti-6Al-4V after HIP are shown in Table 20 and are compared to the pre-HIP properties. The post-HIP properties exceed AiResearch Specification minima and differ from those measured before HIP by showing an approximately 3 ksi lower yield strength and a 6 percent higher elongation. Since the beta transus temperature of the bulk alloy was not exceeded during HIP, the tensile properties are probably controlled by the cooling rate in the HIP

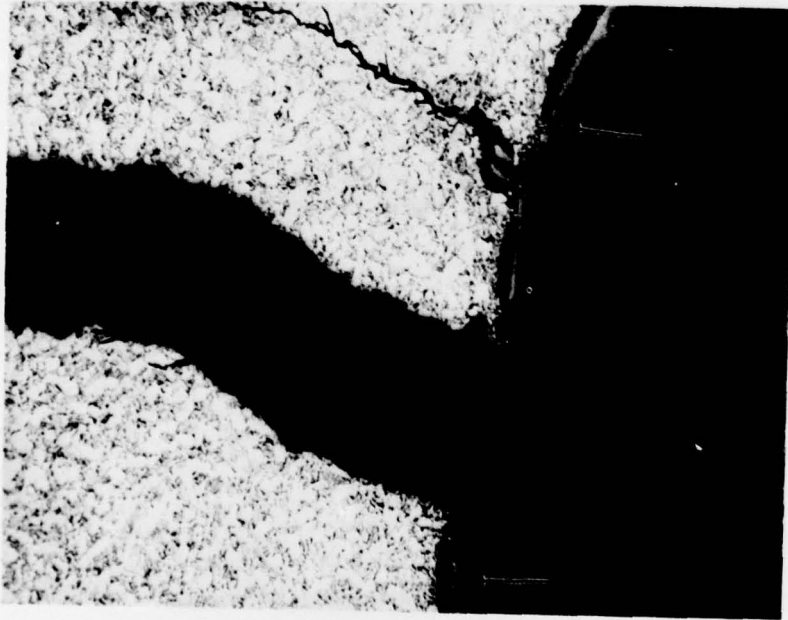

(A)

ETCHANT: KROLLS      MAG: 100X

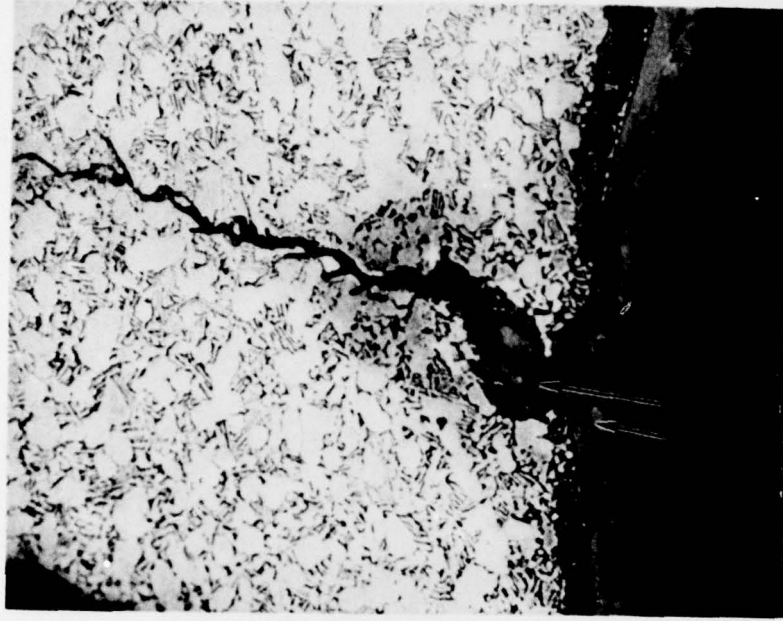

(B)

ETCHANT: KROLLS      MAG: 200X

Figure 44. Cracks in Ti-6Al-4V Alloy Compressor Disk.  
A - Large Crack that was not Bridged Plus Small Crack.  
B - Small Crack from A with Bridge Material Forced into Crack.  
- Arrows Show Bridge Material.

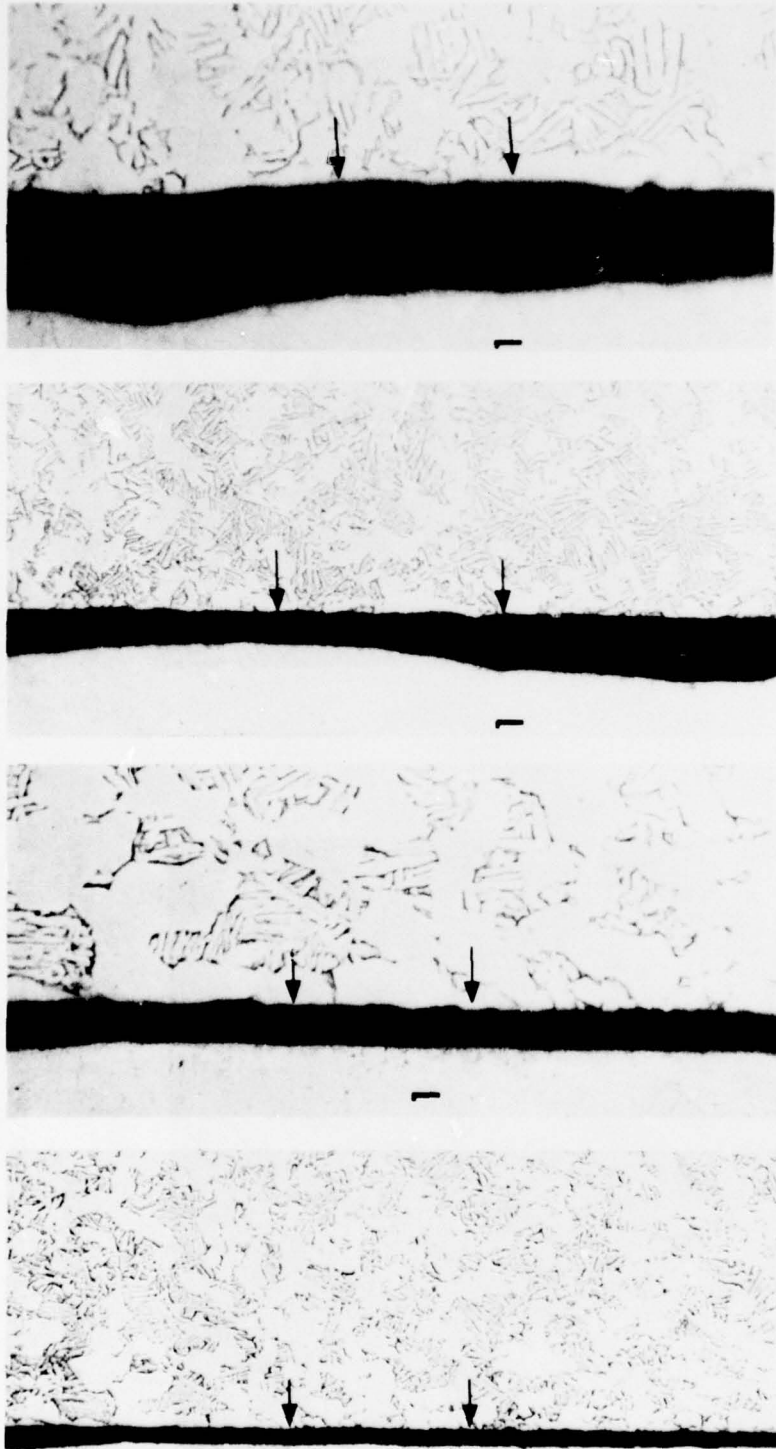

OD

MAG: 200X

MAG: 500X

BASE OF DOVETAIL

MAG: 200X

MAG: 500X

Figure 45. Surface of Unbridged and HIPped Ti-6Al-4V Compressor Disk S/N 4774. 1 Indicates Plating Used in Metallographic Preparation. Arrows Indicate Surface of Disk. Etchant: Krolls

TABLE 20. COMPARISON OF PRE-HIP AND POST-HIP ROOM-TEMPERATURE TENSILE PROPERTIES OF THE Ti-6Al-4V ALLOY COMPRESSOR DISKS.

Test Part (Post-HIP)	0.2% Y.S. (ksi)	Ultimate Strength (ksi)	Percent Elongation	Percent R of A
0-2	124.8	140.9	15.7	48.6
4-3	129.5	142.9	19.3	43.6
4-7	133.4	147.0	15.3	43.2
5-3	127.9	137.8	18.3	38.3
6-3	134.1	145.7	18.5	39.9
6-4	136.0	147.0	17.4	45.4
74-2	129.4	142.0	18.4	38.0
Average Post-HIP	130.7	143.3	17.6	42.4
Average Pre-HIP	134.0	143.6	12.0	41.6
AiResearch AND AMS 4928 Specification Minimums	120.0	130.0	10.0	25.0

autoclave. The properties measured suggest a fairly slow cooling rate, which was the case (rate measured was 160°F per hour).

#### 2.4.3.1.3 Low-Cycle-Fatigue Properties

The low-cycle-fatigue (LCF) test bars were prepared in a similar manner to those machined before HIP and the load control test conditions remained unchanged. Figure 46 shows a plot of the pre- and post-HIP LCF data generated. Comparison of the estimated  $3\sigma$  minimum properties indicates the HIPped material to be better in LCF than the un-HIPped material, but not by a significant amount.

#### 2.4.3.1.4 Transmission Electron Microscopy (TEM)

The TEM analysis on thin films produced from HIPped Ti-6Al-4V showed a reduction in the dislocation density when compared to the pre-HIP samples. Densities were reduced from approximately  $10^9$ - $10^{10}$  per square centimeter to approximately  $10^7$ - $10^8$  per square centimeter. Post HIP dislocation densities were not greatly reduced due to the fact that a two-phase structure (alpha and beta) produces dislocations on cooling due to differential thermal expansion. Figure 47 shows photographs of the structure taken in the TEM. Comparison of Pre- and Post-HIP samples, under careful examination, did not disclose a fatigue damage mechanism.

#### 2.4.3.2 Waspaloy Turbine Disks

##### 2.4.3.2.1 Metallography

An extensive metallographic examination of the HIPped and heat-treated Waspaloy disks was performed. Figure 48 shows the microstructure comparison of both the pre- and post-HIP of disk Serial No. 1351. The grain size was slightly enlarged by the HIP and subsequent heat treatment but remained in the acceptable range. Figure 49 shows photomicrographs of a

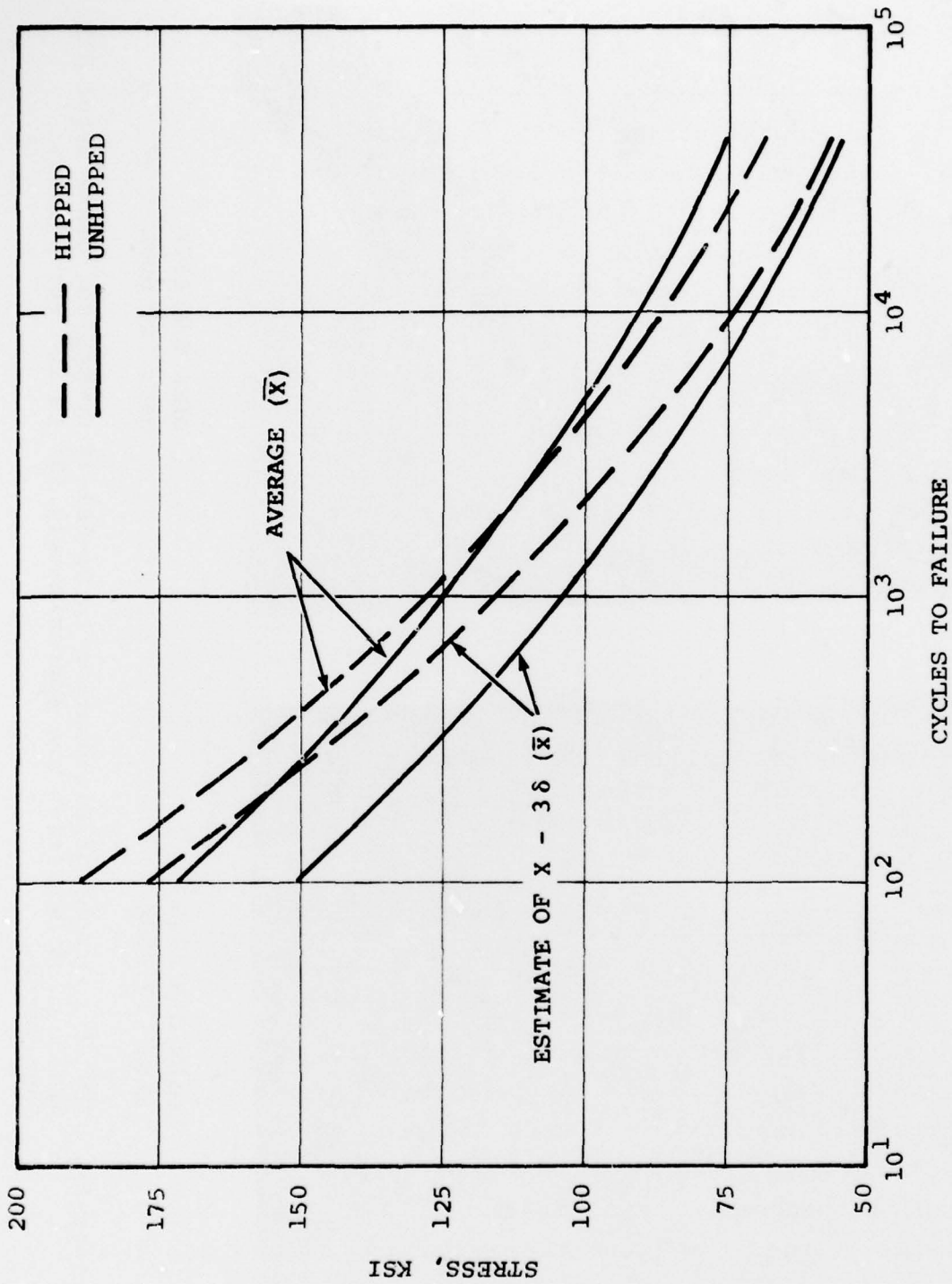
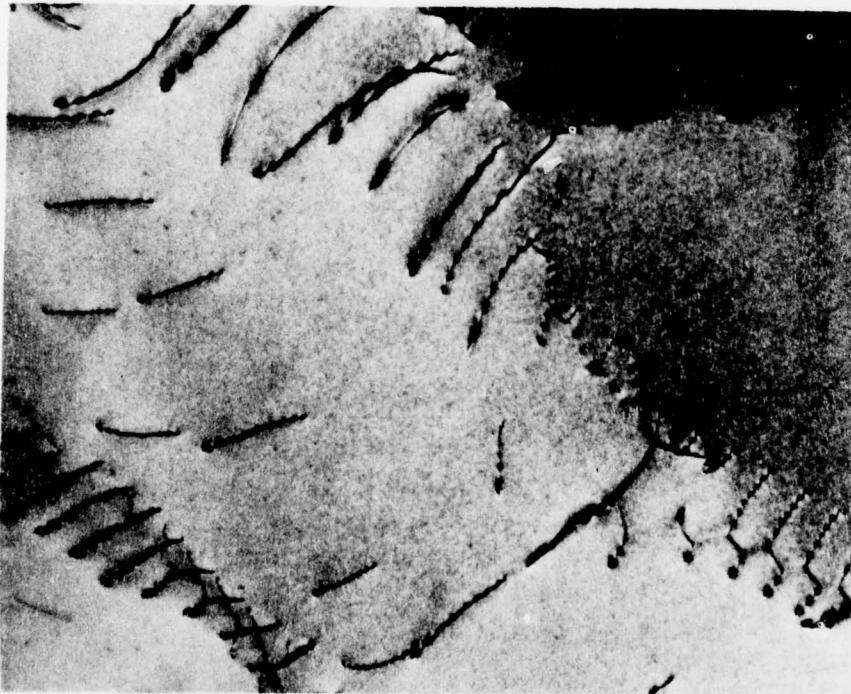
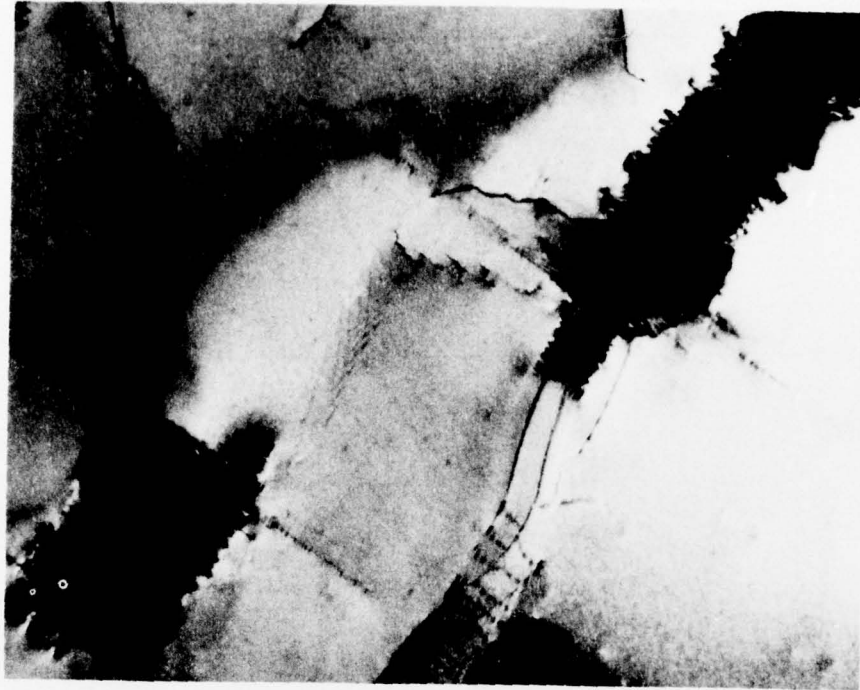

Figure 46. UnHIPped Versus HIPped Load Controlled LCF Curves of Ti-6Al-4V Disk at Room Temperature.



DISK S/N 4740  
MAG: 17,000X



DISK S/N 4774  
MAG: 17,000X

Figure 47. TEM Photographs of Dislocation in Ti-6Al-4V Compressor Disks after HIP. Dislocation Densities are Approximately  $10^7$  to  $10^8$  Per Square Centimeter.

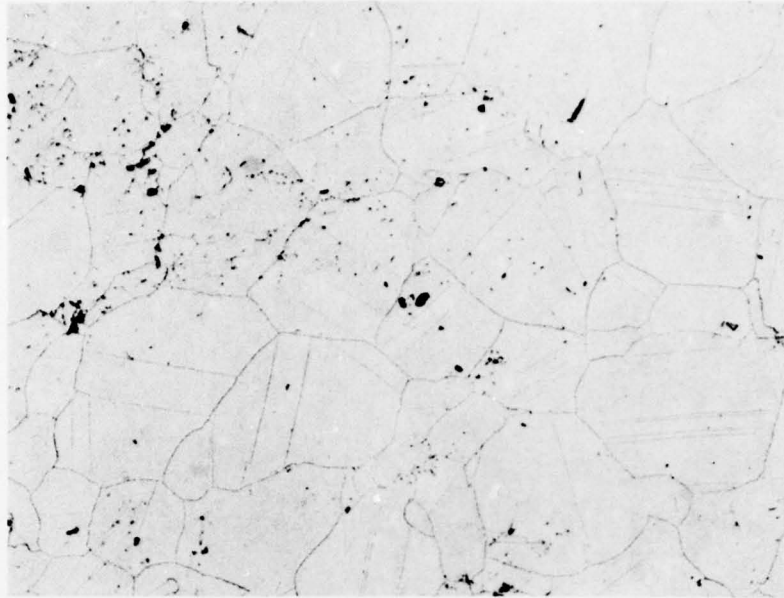

POST-HIP

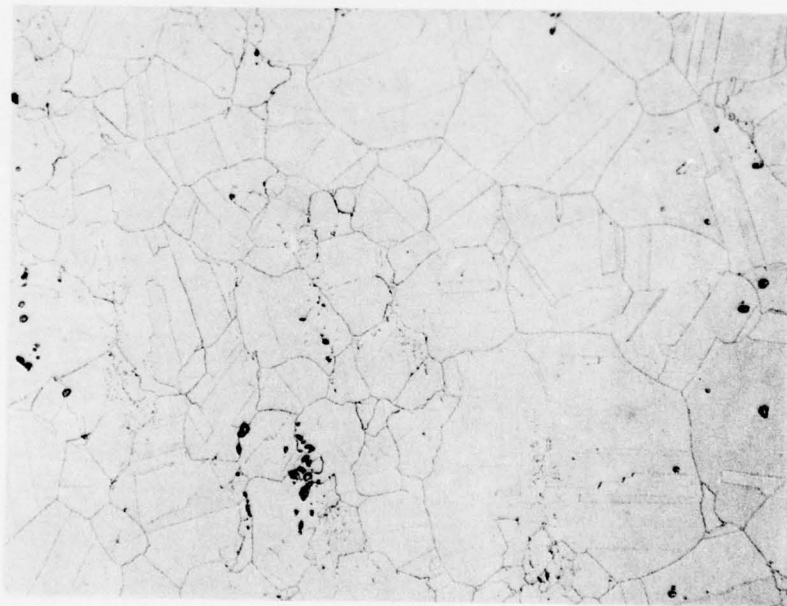

PRE-HIP

Figure 48. Pre-HIP and Post-HIP Microstructures of Waspaloy  
Disk Serial No. 1351 Etchant: Kallings  
MAG: 100X

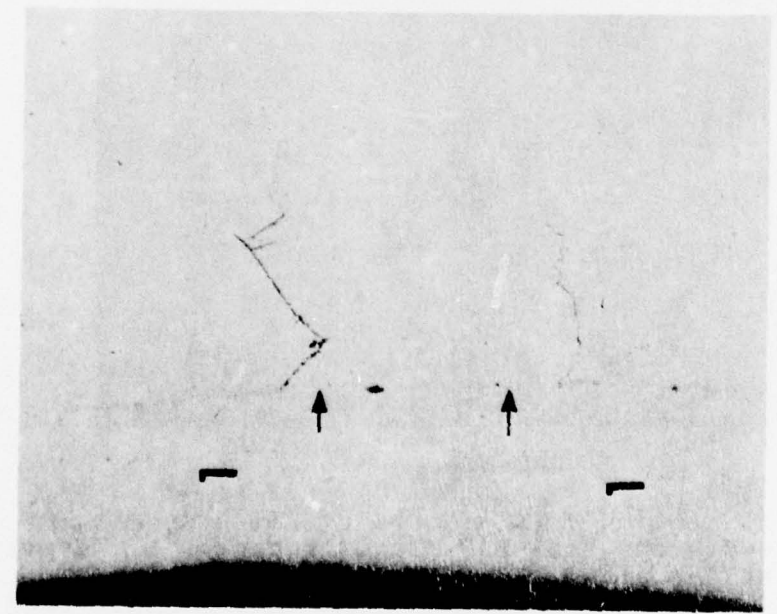

UNETCHED

ARROWS DENOTE ORIGINAL DISK SURFACE

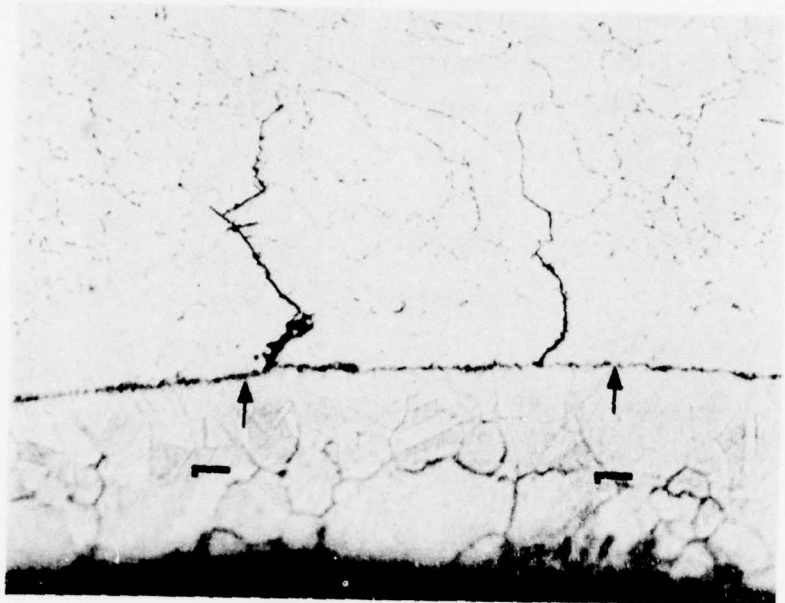

KALLINGS ETCH

Figure 49. Base of Firtree in Waspaloy Turbine Disk after HIP and Heat Treatment. Cracks are Bridged with Pure Nickel (Layer 1) Bridge to Form a Seal During HIP. Mag.: 400X

section made through the base of a firtree of a field-service disk. This particular blade slot exhibited cracks that were produced in service and were subsequently bridged with nickel prior to HIP. Note the cracks are bridged but HIP did not create a bond. Denuding of the gamma prime below the original disk surface is evident. The aluminum and titanium appear to be diffusing into the pure nickel plate leaving the Waspaloy deficient in the alloying elements.

#### 2.4.3.2.2 Tensile Properties

The 1000°F tensile properties of Waspaloy after HIP and heat treatment are given in Table 21 and are compared to the pre-HIP results. The post-HIP properties closely duplicate those measured on the field-service disks before HIP and, with the exception of one yield strength result, exceed AiResearch specification minimums. The fracture face of the tensile bar showing the one low yield-strength value was examined but nothing unusual was noted.

#### 2.4.3.2.3 Low-Cycle Fatigue

The load control low-cycle-fatigue (LCF) testing on the post-HIP Waspaloy disks was conducted at 1000°F using notched bars ( $K_t \approx 2$ ) and cycled in tension ( $A=1.0$ ), similar to the pre-HIP testing. Figure 50 shows the results compared to the pre-HIP baseline. Both curves are extremely close with the three sigma ( $3\sigma$ ) minimum estimates showing that the pre-HIP tests exhibited less scatter than post-HIP.

#### 2.4.3.2.4 Transmission Electron Microscopy (TEM)

The TEM analysis on thin films produced from HIPped Waspaloy showed a reduction in the dislocation density when compared to

TABLE 21. COMPARISON OF PRE-HIP AND POST-HIP  
1000°F. TENSILE PROPERTIES OF  
WASPALOY TURBINE DISKS.

Specimen (Post HIP)	0.2% YS (ksi)	Ultimate Strength (ksi)	% Elongation	Percent R of A
1H	121.2	165.3	23.9	29.4
01H	110.7	160.1	24.9	27.7
2H	117.1	165.0	19.6	25.3
02H	102.2	161.7	25.0	25.6
03H	110.3	164.7	24.9	29.3
51H	114.9	163.6	17.8	24.2
52H	111.8	163.5	21.7	27.5
53H	<u>112.7</u>	<u>162.0</u>	<u>20.0</u>	<u>27.3</u>
Average Post-HIP	112.7	163.2	22.2	27.0
Average Pre-HIP	113.1	163.0	18.2	22.0
AIResearch Specification Minimum	110.0	160.0	12.0	15.0

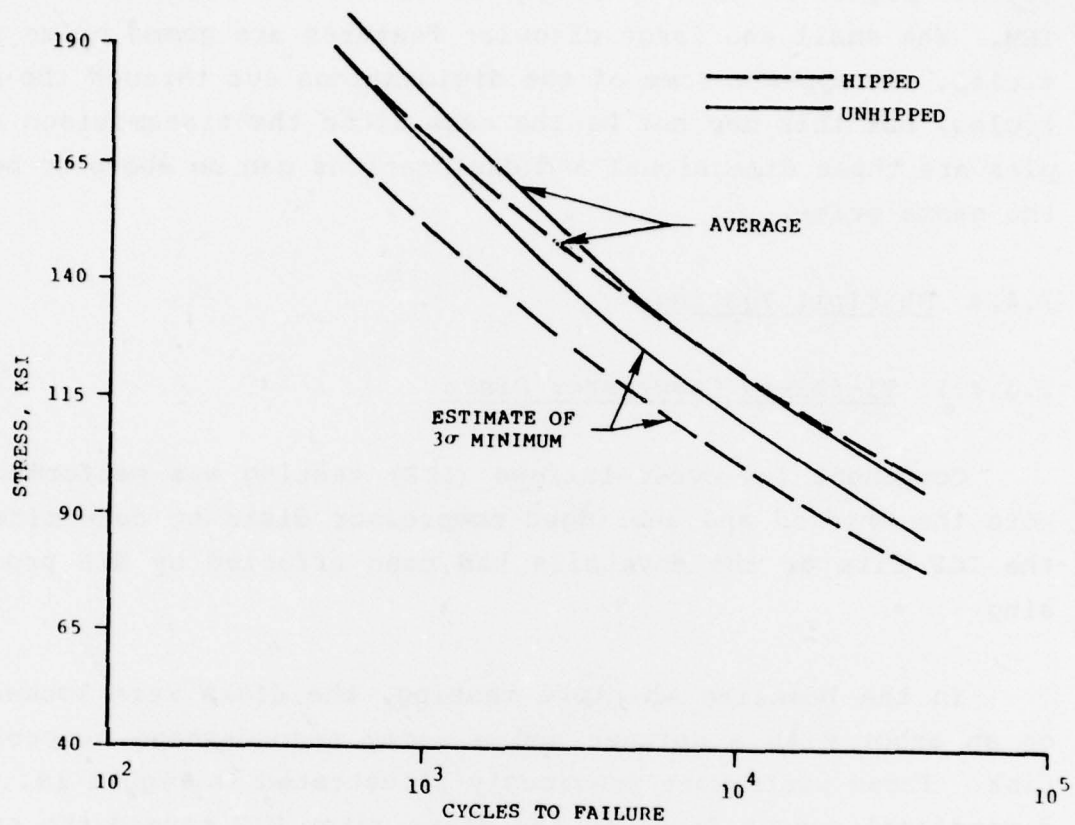

Figure 50. UnHipped Versus Hipped Load Controlled LCF Properties of Waspaloy Turbine Disks at 1000°F.

pre-HIP samples. Densities were reduced from approximately  $10^7$ - $10^8$  per square centimeter to approximately  $10^6$  per square centimeter. Figure 51 shows photographs of the structure taken in the TEM. The small and large circular features are gamma prime particles. It appears some of the dislocations cut through the particles, but this may not be the case since the transmission samples are three dimensional and dislocations can be above or below the gamma prime.

#### 2.4.4 Whirlpit Testing

##### 2.4.4.1 Ti-6Al-4V Compressor Disks

Component low-cycle-fatigue (LCF) testing was performed on both the bridged and unbridged compressor disks to determine if the LCF life of the dovetails had been affected by HIP processing.

In the baseline whirlpit testing, the disks were locked-up on an arbor with a spinner and a dummy second-stage compressor disk. These parts were previously illustrated in Figure 19. The dimensional runout found on the disks after HIP caused the spinner and second-stage dummy to contact the disk in the wrong areas. This would have induced unrealistic stresses in the disk, so the disks were spun without spinners, and in one case, without a dummy second-stage disk. The stresses induced by the dummy and spinner in a normal configuration were not considered substantial enough to affect the results.

The disks were cycled (as before) from a low-speed range of 3000-3500 rpm to a high-speed range of 29,600-29,800 rpm. The cycles were performed in the following increments:

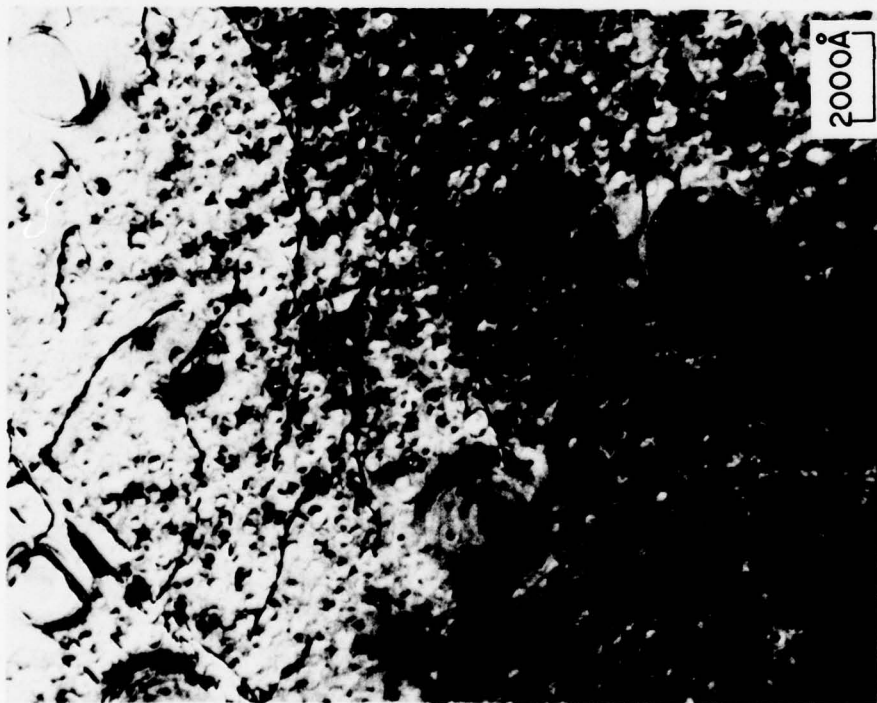

DISK S/N 320

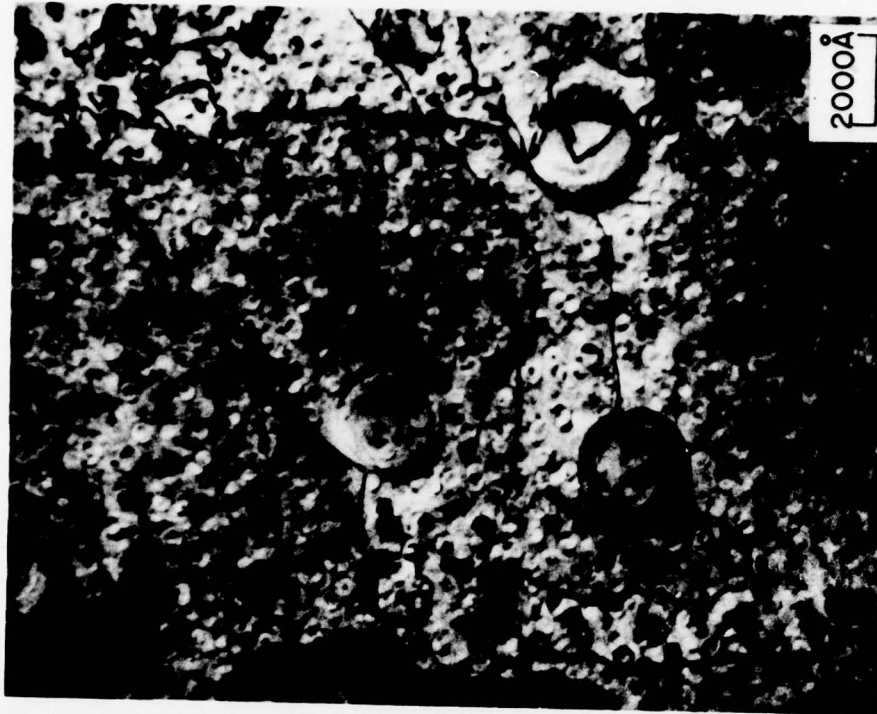

DISK S/N 255

Figure 51. TEM Examination Of Waspaloy After HIP. The Dislocation Density is Estimated to be  $10^8$  per Square Centimeter (Mag: 27000X).

<u>Test</u>	<u>Cycles/Test</u>	<u>Total Cycles</u>
1	1	1
2	9	10
3	40	50
4	50	100
5	150	250
6	250	500
7	500	1000
.	.	.
.	.	.
.	.	.
.	500	5000

After each test, the disks were debladed and an eddy-current inspection performed to check for cracks in the dovetail.

The bridged disk, Serial No. 717, failed after 1410 cycles and is shown in the cyclic whirlpit in Figure 52. Eddy-current inspection performed at 1000 cycles failed to indicate cracks large enough to effect a disk burst, yet 410 cycles later, catastrophic failure occurred. A metallurgical analysis of the failed disk, was performed to determine the cause of failure. It was found that large fatigue cracks existed in many of the dovetail corners and most were large enough to have caused disk separation. The eddy-current inspection correlation to actual crack depths was poor, with most of the cracks being larger than predicted by NDE inspection. The appearance of the cracks in the surface layer indicated that the disk was brittle. This was logical since the stabilized beta layer present on the surface can exhibit lower ductility than the normal alpha plus beta structure.

Prior to additional spin testing, the decision was made to attempt to remove the brittle stabilized beta layer by either chemically milling or utilizing a heat treatment that could possibly homogenize the microstructure. However, solution treatments at 1650°F and 1825°F were not successful in diffusing the copper out of the beta layer and the resultant microstructure

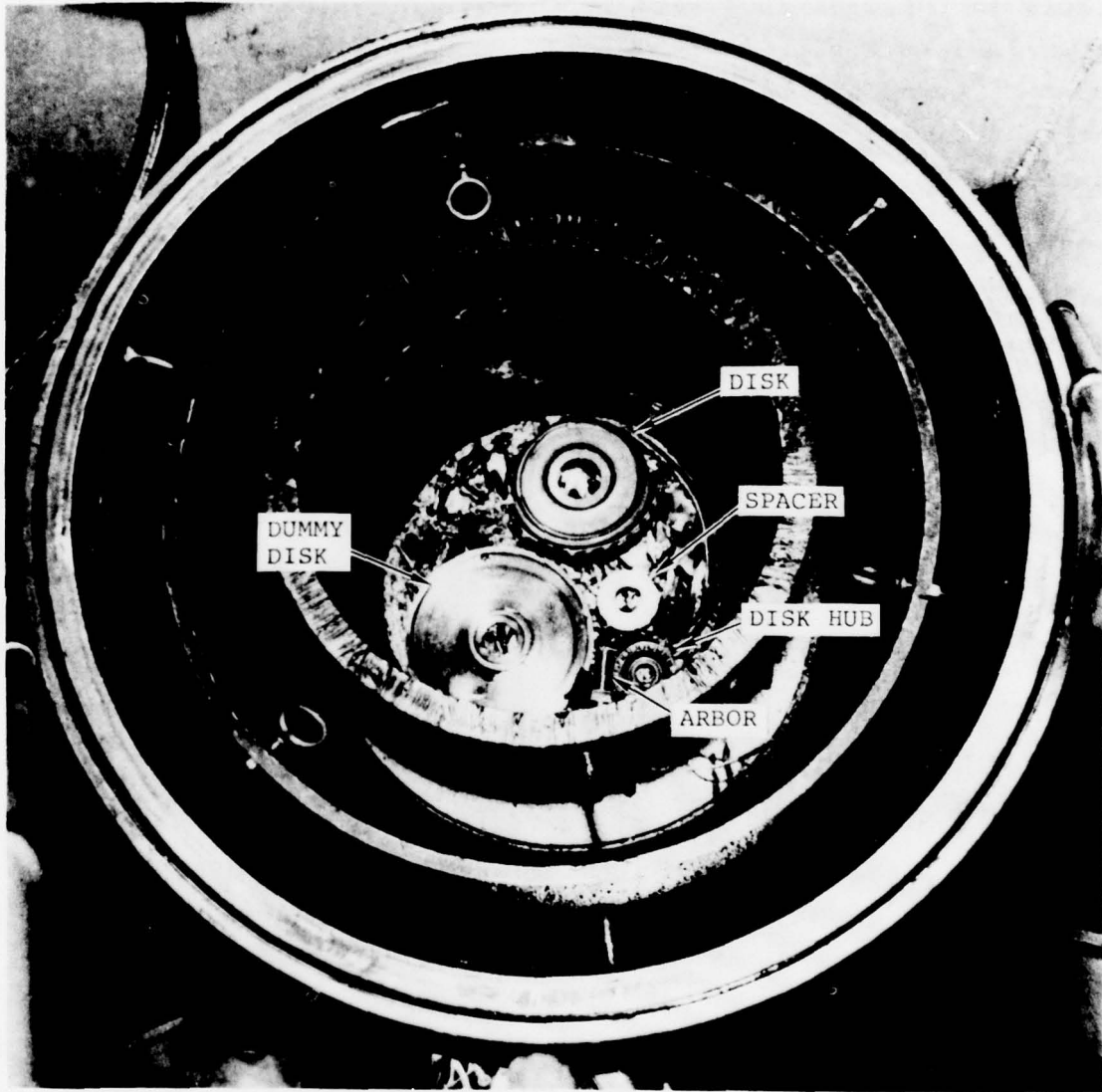

Figure 52. Ti-6Al-4V Alloy Compressor Disk S/N 717 Failure After 1410 Cycles in the Cyclic Whirlpit.

remained the same. The heat-treatment process was eliminated from further evaluation.

One of the disks that had been bridged prior to HIP (Serial No. 4802) was chemically milled to remove the beta stabilized layer. It was spin tested and was suspended at 3200 cycles when cracks in the disk face were detected. A typical face crack is shown in Figure 53. A metallographic sample showed that all of the beta layer had been removed during the chemical milling and the surface microstructure was similar to the internal structure of the disk.

The other bridged disk (Serial No. 2561) was also chem-milled, and vacuum annealed to remove traces of hydrogen caused by chem-milling. It was suspended from testing at 3510 cycles due to cracks detected on the face.

The three unbridged disks were cycled until cracks on the faces were discovered. Eddy-current inspections were conducted after every 500 cycles, and a visual inspection was performed after each 100 cycles. Cycling was stopped on Serial No. 4843 after 2200 cycles when a crack was detected. Cycling was stopped on Serial No. 4778 after 2900 cycles when a crack similar to that shown in Figure 53 was detected; and Serial No. 1427 was suspended at 3800 cycles.

Table 22 shows the results of the compressor disk whirlpit spin testing with the new disk baseline data included for comparison. Included on Table 22 is additional new disk baseline data generated by AiResearch from an in-house program. As noted, the data is consistent with the data generated during the HIP program. The average life of the bridged and chem-milled disks is about 50 percent of the baseline and the average life of the non-bridged disks is about 40 percent of the baseline.

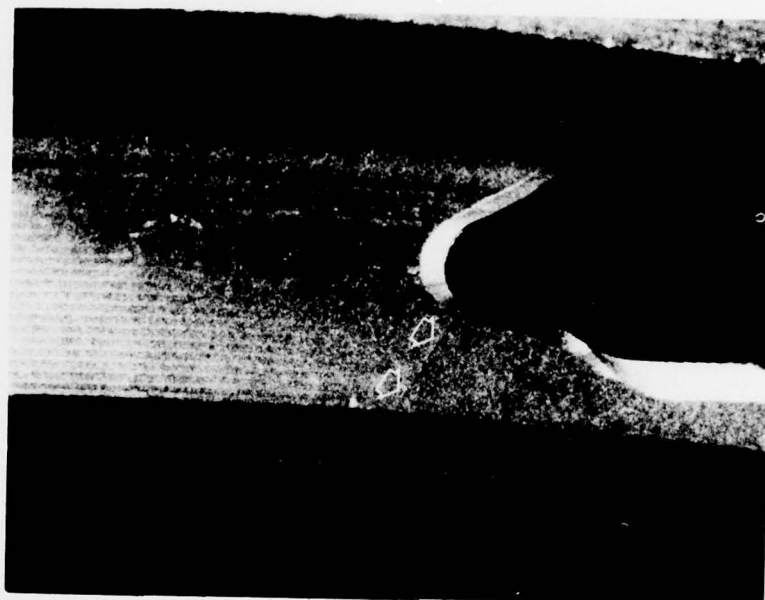

Figure 53. Crack Extending from the Dovetail on the Face of HIPped Compressor Disk S/N 4843. (Arrows Show Crack) MAG: Approx. 3X.

TABLE 22. SUMMARY OF Ti-6Al-4V COMPRESSOR  
DISK CYCLIC SPIN TESTING AFTER HIP  
COMPARED TO NEW DISK BASELINE.

Disk S/N	Field-Service Cycles	Crack Severity	Bridged	Chem-Milled Bridged Layer	No. of Whirlpit Cycles
717	N.A.*	Severe	Yes	No	1410F**
4843	N.A.	Light-to-Moderate	No	--	2200S***
4778	3275	Light	No	--	2900S
4802	N.A.	Moderate	Yes	Yes	3200S
1427	N.A.	Light	No	--	3800S
2561	4240	Severe	Yes	Yes	3510S
Original New Disk Baseline (3 Disks)	None		No	--	5000S
	None		No	--	6500S
	None		No	--	10,500S
Additional New Disk Baseline (AiResearch Generated-3 Disks)	None		No	--	6960S
	None		No	--	7500S
	None		No	--	9100S

\*Not Available  
 \*\*F = Fractured  
 \*\*\*S = Suspended - Cracks Evident in Disk Face

It is possible that the three disks which were HIPped without bridging had small existing cracks (that were not healed because of lack of bridging) and the cyclic-spin testing continued their growth. Addition of these estimated or recorded field-service cycles to the whirlpit cycles gave a total that was in the range of the new disk baseline, and hence, the fatigue life remaining after HIP may be comparable to that before HIP. However, it should be noted that nearly every dovetail corner of the HIPped disks was cracked severely at the time of test suspension. This was different from the new disk baseline testing where a number of corners remained uncracked after cycling. This phenomenon of nearly every dovetail being cracked was evident on the bridged and chemically milled disks also. On these disks, the milling would have removed the majority, if not all, of the pre-existing cracks, and those not removed would have been bonded during HIP. In order for the large number of corners to have been cracked in such short cycle lives, early crack initiation must have been occurring.

To substantiate this hypothesis, cracked dovetails were broken open and the surfaces were examined on the SEM. Counts of the number of cycles were made and correlated to the depth of crack propagation. (Figure 54 shows a typical fatigue striation photograph.) From this data, propagation rates were determined for un-HIPped and HIPped disks. The results showed that the rates were similar for both cases, i.e., un-HIPped and HIPped. Therefore, if the crack propagation rates are similar, then crack initiation occurs sooner for the post-HIP material than for the un-HIPped material, since the life ratio is approximately one-half.

The early crack initiation could have been caused by a number of conditions; (1) surface contamination during HIP, (2) chemistry changes on the surface, and (3) relaxation of the residual stresses caused by the original machining and broaching of the disk dovetails. To investigate these possibilities, detailed Scanning Electron Microscope (SEM) analyses, Auger Spectroscopy,

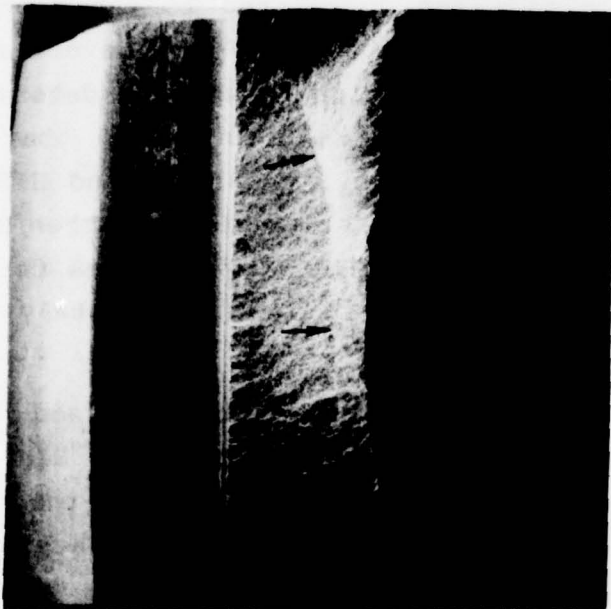

IMAGE 1

Crack in Dovetail No. 15.

A Designates Location  
Of Image 2.

Arrows Show Progression of  
Fatigue Crack.



IMAGE 2

Fatigue Striations  
Estimated at 75,000/inch

MAG: 10000X

Figure 54. Location of LCF Crack and SEM Image of Fatigue Striations. Disk S/N 4873 (New Disk Baseline).

and X-ray residual stress measurements were performed on un-HIPped and HIPped disk samples. SEM analysis of the broached dovetail surface indicated a surface change occurred during HIP. Figure 55 shows before and after photographs indicating that most of the residual broach marks were removed by a thermal etching or thermal faceting. It was not known to what degree this thermally etched surface might affect fatigue crack initiation.

The X-ray analyses performed in the SEM indicated a reduction in aluminum on the surface. Auger spectroscopy was performed to determine the amount of aluminum loss, and to detect if contamination was introduced into the surface during HIP. Table 23 shows the Auger results. At a depth of 3000Å below the surface (0.000012 inch), the aluminum was down from the 6-percent level to approximately 4 percent. The vanadium was up from the nominal 4 percent to over 7 percent. The results from a HIPped sample cross section (0.100-inch below the surface) indicated a near normal 6-percent vanadium, 4-percent aluminum analysis. A chem-milled piece of the same disk (with 0.004-inch removed) showed a reduction in aluminum and an increase in vanadium but not as drastic as the HIPped surface. It is not known to what extent these chemistry variations affected fatigue initiation.

Based on AiResearch experience in attempting to find dovetail cracks with fluorescent penetrants (refer to Section 2.1.2), compressive stresses in as-broached disks are high in magnitude because they hold cracks tightly closed and do not allow penetrant intrusion. In an attempt to determine if relaxation of residual stresses occurred during HIP, X-ray residual stresses were determined on the OD of disks before and after HIP. The OD was used because samples at the base of the dovetail were not available. Results were inconclusive as to any reduction in compressive residual stresses.



AFTER HIP

DIRECTION OF  
BROACHING

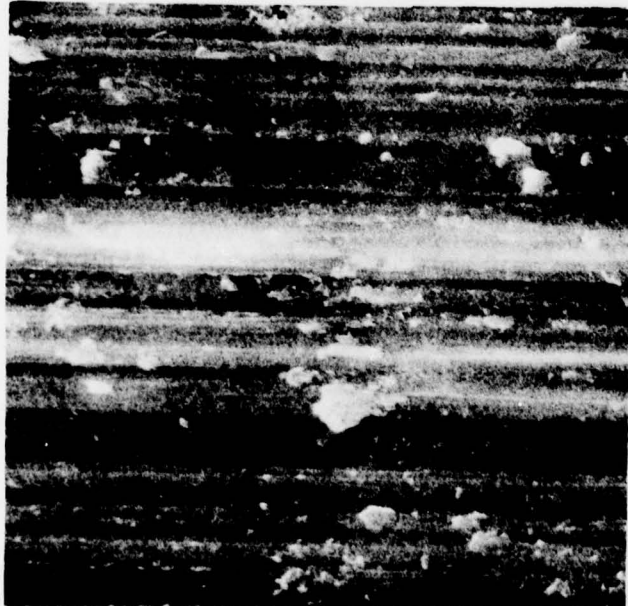

BEFORE HIP

Figure 55. SEM Analysis of Dovetail Surface Before and After HIP.  
Mag.: 5000X

TABLE 23. AUGER SPECTROSCOPY CHEMICAL ANALYSIS AT A DEPTH OF 0.000012 INCH BELOW THE SURFACE. ALL SAMPLES FROM DISK SERIAL NO. 4774.

Sample Identification	Weight Percent		
	Al	Ti	V
1. Before HIP	6.0	88.8	3.8
2. After HIP	4.1	86.7	7.6
3. After HIP Cross Section (0.100 inch below surface)	5.8	89.6	3.0
4. After HIP and Chem-Milled (0.004 inch removed)	4.6	86.9	4.8

TABLE 24. RESIDUAL GAS ANALYSES OF SAMPLES TAKEN FROM DISK SERIAL NO. 4774 BEFORE AND AFTER HIP.

<u>Element</u>	<u>Before HIP</u>	<u>After HIP</u>
Hydrogen	40 ppm	47 ppm
Oxygen	0.144%	0.155%
Nitrogen	0.004%	0.003%

Residual gas analyses performed on samples from the same disk before and after HIP are presented in Table 24. The analyses show a slight increase in the oxygen level after HIP, but the amount is insignificant.

At the conclusion of the above investigation, it was not possible to establish the exact cause for the early crack initiation. It is possible that surface alterations, chemical variations, and relaxation of residual stresses may all have contributed.

#### 2.4.4.2 Waspaloy Turbine Disks

Three bridged and one unbridged HIPped turbine disks were cycled without curvic couplings and without blades (technique discussed in Section 2.1.5.2). All four disks were subjected to fluorescent-penetrant inspection prior to whirlpit testing, and no indications of cracks were found. The fluorescent penetrant technique used was similar to that described in Section 2.1.2.2.

As previously determined on baseline disks when reaching spin test speed, Waspaloy turbine disks exhibited additional plastic growth after HIP. The disks were gradually taken up to the desired operating speed while the tooling on which the disk was spun was adjusted for this growth. After the maximum speed was attained, the plan called for the disks to be cycled from a low speed of 5000 to 5500 rpm to a high speed of 52,900 to 53,100 rpm. The number of cycles scheduled to be spun is shown below.

<u>Run</u>	<u>Cycles</u>	<u>Total</u>
1	10	10
2	40	50
3	50	100
4	150	250
5	250	500
6	500	1000
	.	.
	.	.
	.	.
	500	10,000 est.

After each run, the disks were inspected for cracks using fluorescent penetrants.

The first bridged disk, Serial No. 2685, which had been spin tested prior to HIP, was cycled in steps of increasing speed to monitor bore growth. After eleven cycles (maximum speed of 53,100 rpm), cracks were detected at the base of the firtrees in locations matching those present prior to bridging, HIP, and heat treatment. Subsequently, field-service disks (Serial Nos. 90309 and 727), which had exhibited cracks prior to bridging and HIP, were spun. These two disks were only spun to maximum speeds of 51,800 rpm and 52,200 rpm, respectively, (the minimum was 52,900 rpm) before cracks at the base of the firtree were detected and the disks were retired.

Tensile properties were measured in samples taken from disk Serial Nos. 90309 and 727, and the results indicated that the strengths of the disks were acceptable according to AiResearch specifications, and exceeded those reported in Table 21 for the post-HIP material. Metallographic examination of a number of cracked firtrees showed large cracks which appeared to have been bridged by the nickel plate but were not bonded during HIP (Figure 56). It appears that the plastic deformation occurring at the firtree base during cyclic-spin testing has ruptured the bridge and exposed the existing cracks below.

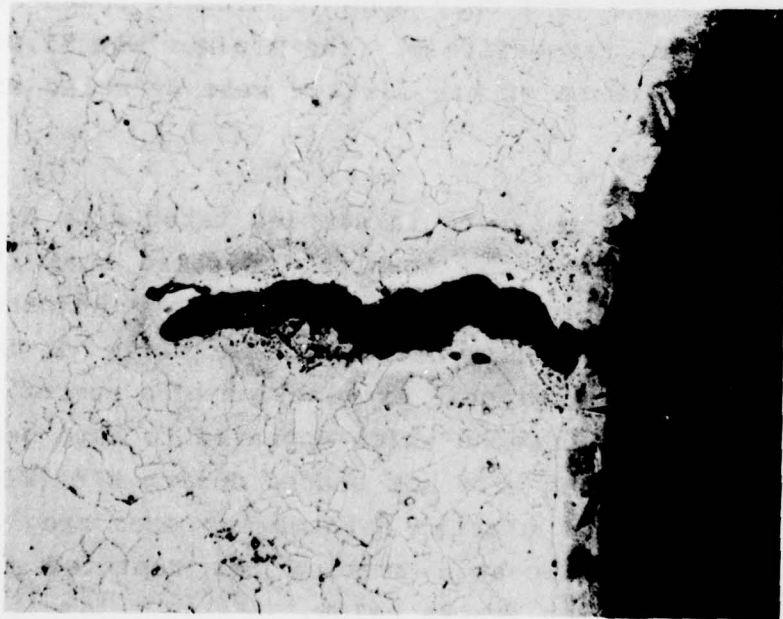

DISK S/N 727

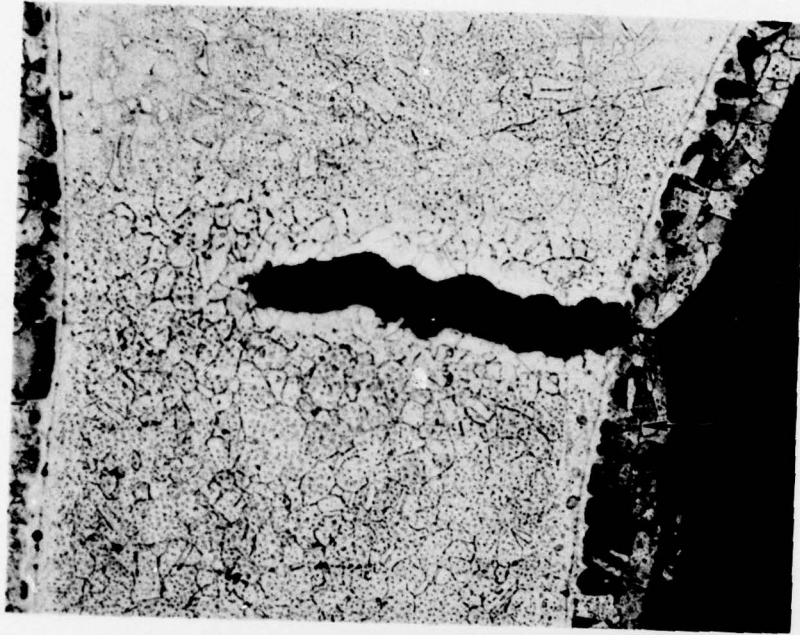

DISK S/N 90309

Figure 56. Cross Section of the Bases of Two Firtrees After Bridging with Nickel, HIP, Heat Treatment, and Spin Testing. Etchant: Modified Kallings. Mag.: 100X. Arrows Indicate Nickel Bridge.

The unbridged disk returned from field-service (Serial No. 2909) was spun to 10,000 cycles and suspended. The inspection record is shown in Table 25. For comparison, three new disk baseline fatigue samples had the following results:

<u>Serial No.</u>	<u>No. Cycles</u>	<u>No. of Cracked Firtrees</u>
2911	7000	None - Suspended from further testing
2685	5500	14
1799	6070	12

The post-HIP test sample appears equal to or better than the baseline samples in resistance to fatigue cracking. The disk was sectioned for examination of the cracks. The appearance of the cracks is similar to that found in the cracked field-service disks as shown in Figure 57.

Figure 58 shows the appearance of the surface of Waspaloy in the SEM before and after HIP. The area is just below the base of the firtree and was oxidized in engine service. The HIPped surface shows additional oxidation present but it is not considered detrimental.

## 2.5 Environmental Consequences

In evaluating the environmental consequences of the HIP program both in this project and in potential scale-up to production quantities, the process that each disk is subjected to must be addressed. After a disk has reached the design life limit, it is removed from the turbine engine assembly and receives the standard cleaning procedure required for detailed inspection. If cracks in the blade attachment regions are found, the disk requires additional cleaning and bridging of the cracks to make the subsequent HIP effective. The disk is reverse sputter cleaned in a vacuum, followed by bridging by ion plating with the

**TABLE 25. INSPECTION RECORD OF HIPPED  
TURBINE DISK SERIAL NO. 2909**

<u>Condition</u>	<u>Group VI Penetrant Inspection Results</u>
Returned from Field Service 3535 hours	No Cracks
HIPPed and Heat Treated	No Cracks
Cyclic Spin Testing; Cycles	
500	No Cracks
1000	No Cracks
1500	No Cracks
2000	No Cracks
2500	No Cracks
3000	No Cracks
3500	No Cracks
4000	No Cracks
4500	No Cracks
5000	No Cracks
5500	No Cracks
6000	1 Crack
6500	2 Cracks
7500	4 Cracks
8000	4 Cracks
8500	4 Cracks
9500	4 Cracks
10000	Retired

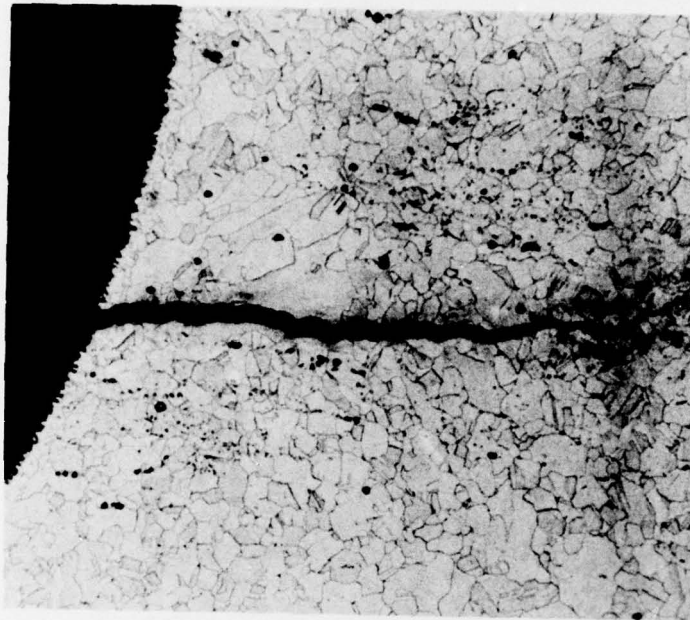

KALLINGS ETCH  
HIPPED SPIN TESTED DISK

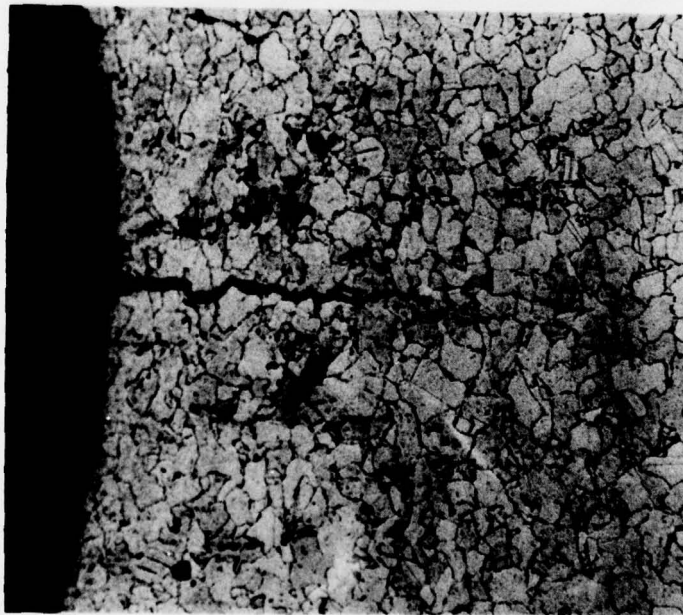

KALLINGS ETCH  
FIELD-SERVICE DISK

Figure 57. Appearance of Fatigue Cracks at the Base of Firtrees in Field-Service Disk Serial No. 90149A and in Cyclic-Spin Tested HIPped Disk Serial No. 2909. Mag.: 200X



BEFORE HIP

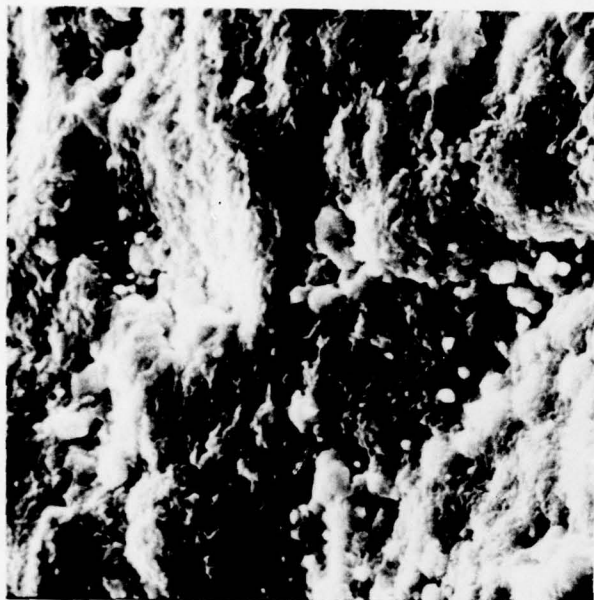

AFTER HIP

Figure 58. Appearance in the SEM, of Waspaloy Before and After HIP.  
Mag.: 5000X

appropriate material. The HIP process is now performed with the disk under high argon gas pressure and at an elevated temperature. Material property requirements generally mean that a post-HIP heat treatment is necessary, and this is also performed in a vacuum.

The main contacts of the HIP rejuvenation process with the environment are in the areas of material and power usage. The material used includes the substances used for bridging, the cooling water used in ion plating and heat treating, and the argon gas used in the HIP process. The only material released to the environment is the unreclaimed portion of the argon gas used in HIPping. This is an inert gas that is not harmful to the environment.

The amount of material and power used in the HIP rejuvenation of gas turbine engine compressor and turbine disks must be compared to the amount that would be used to manufacture new disks. It is anticipated that the HIP process will have the overall effect of conserving strategic materials and reducing energy consumption, since the energy required to perform HIP and heat-treat rejuvenation will be far less than the energy required to produce new disks. New disk production involves energy consumption in mining, metal refining, double vacuum melting, forging, heat treatment, and machining; while a successful HIP plus heat-treatment rejuvenation will only have these two main sources of energy consumption.

### 3.0 CONCLUSIONS AND RECOMMENDATIONS

The HIP Rejuvenation of Disks Program has been analogous to an exercise to salvage finish processed metallic parts that were improperly heat treated during their manufacture. It was not surprising that the same successes and difficulties encountered with HIP processing are expected in production salvage situations with new parts, since HIP is basically a high-temperature heat treatment at circa 1000 atmospheres. The conclusions and recommendations given below are broken down by alloy type.

#### 3.1 Ti-6Al-4V Compressor Disks

The major conclusions and recommendations reached for the Ti-6Al-4V compressor disks are given below:

- o The tensile strength, microstructure, and uniaxial LCF properties of the HIPped material are equivalent to the original wrought disk properties when measured on samples taken from the disk webs.
- o Bridging and HIP bonding of field-service fatigue cracks was accomplished as demonstrated by metallographic evidence. However, an undesirable beta case was found below the bridge on the original disk surface.
- o Disk dimensions were out of blueprint after HIP. A controlled initial microstructure, such as produced by recrystallization annealing, and rigid disk fixturing would be required to overcome this movement.
- o The eddy-current technique for dovetail fatigue crack detection was effective on field-service disks, but was inadequate to determine crack closure by HIP bonding.

- o Dovetail LCF life of the HIPped disks was 40 to 50 percent of the baseline un-HIPped disks. It is recommended that shot peening be used to introduce compressive stresses in the titanium disks to improve their life after HIPping.
- o It is recommended that ion plating be used for crack bridging, but a satisfactory substitution for copper must be identified to eliminate the beta case.
- o Emerging NDE techniques such as advanced eddy current or ultrasonics need to be evaluated to examine dovetails for fatigue cracks.

### 3.2 Waspaloy Turbine Disks

The major conclusions and recommendations reached for the Waspaloy turbine disks are given below:

- o The tensile strength, microstructure, and uniaxial LCF properties of the HIPped material were equivalent to the original wrought disk properties.
- o Uncracked field-service retired disks can be successfully HIP rejuvenated to restore their original LCF life.
- o Bridging of field-service fatigue cracks was accomplished, but crack surface bonding was not demonstrated during HIP. A cleaning technique that removes oxides present on the crack surfaces is required prior to bridging.

- o Cracked field-service disks were not rejuvenated due to the difficulty in removing oxides from cracks. Oxides make bonding impossible but even with clean surfaces, bonding may be difficult or impossible.
  
- o Disk dimensions were out of blueprint after HIP. Rigid fixtures are recommended to maintain critical dimensions.
  
- o The development of an eddy-current or ultrasonic NDE technique is recommended to evaluate crack bonding through the bridge layer.

## REFERENCES

1. Clauer, A. H., et al., "Investigation of Rejuvenation of Fatigue Damage in Ti-6Al-V" Air Force Materials Laboratory, AFML-TR-77-107, July, 1977.
2. Clauer, A. H., et al., "Investigation of Rejuvenation of Fatigue Damage in IN-718" Air Force Materials Laboratory, AFML-TR-78-90, August 1976.
3. Marttila, R. H., Giard, J. R., and Sundberg, D. V., Unpublished Research, AiResearch Manufacturing Company of Arizona.