

AD-A078 637

AERONAUTICAL RESEARCH LABS MELBOURNE (AUSTRALIA)
A SUMMARY OF DAMAGE TOLERANCE SPECIFICATIONS WITH EMPHASIS ON M--ETC(U)
FEB 79 J Q CLAYTON
ARI/MAT. 126

F/G 1/3

NL

UNCLASSIFIED

OF 1

AD
A078637



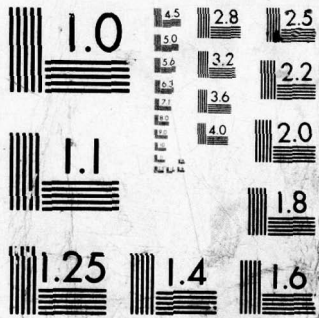
END

DATE

FILMED

80

DDC



MICROCOPY RESOLUTION TEST CHART
NATIONAL BUREAU OF STANDARDS-1963-A

LEVEL

(12)

F



ADA 078637

**DEPARTMENT OF DEFENCE
DEFENCE SCIENCE AND TECHNOLOGY ORGANISATION
AERONAUTICAL RESEARCH LABORATORIES**

MELBOURNE, VICTORIA

MATERIALS NOTE 126

**A SUMMARY OF
DAMAGE TOLERANCE SPECIFICATIONS WITH
EMPHASIS ON MATERIALS AND NDI REQUIREMENTS**

by

J. Q. CLAYTON

Approved for Public Release.



DDC
RECEIVED
DEC 27 1979
REGISTRY
A

DDC FILE COPY

© COMMONWEALTH OF AUSTRALIA 1979

COPY No 12

FEBRUARY, 1979

79 12 27 091

THE UNITED STATES NATIONAL
TECHNICAL INFORMATION SERVICE
IS AUTHORISED TO
REPRODUCE AND SELL THIS REPORT

APPROVED
FOR PUBLIC RELEASE

DEPARTMENT OF DEFENCE
DEFENCE SCIENCE AND TECHNOLOGY ORGANISATION
AERONAUTICAL RESEARCH LABORATORIES

14 ARL 9 MATERIALS NOTE 126

6
**A SUMMARY OF
DAMAGE TOLERANCE SPECIFICATIONS WITH
EMPHASIS ON MATERIALS AND NDI REQUIREMENTS**

11 Feb '79

by

10 J. Q. CLAYTON 12 26

14 ARL/MAT. 126

SUMMARY

Specifications for USAF military aircraft now include damage tolerance and durability as basic structural requirements. The introduction of these requirements into the design and development of future aircraft is briefly described.

The new design analysis assumes the existence of flaws in the structure and considers their growth, at calculable rates, by appropriate cracking processes. Non-destructive inspection (NDI) intervals are then specified according to limits of safe crack growth. Airframe rework and repair requirements are similarly established for a period greater than the design life. Details of damage tolerance requirements, including flaw size assumptions, NDI intervals, etc., are summarized and illustrated.

Under the new requirements, many existing aircraft are considered to be of uncertain structural integrity. The USAF is currently assessing damage tolerance and durability on a wide range of service aircraft. Application of the new requirements and methods of assessing damage tolerance in operational aircraft are described.

CONTENTS

	Page No.
1. INTRODUCTION	1
2. STRUCTURAL INTEGRITY AND GENERAL REQUIREMENTS FOR DAMAGE TOLERANCE AND DURABILITY	1
2.1 Structural Integrity	1
2.2 Definitions	2
2.3 General Damage Tolerance and Durability Requirements	2
2.4 Damage Tolerance Design Concepts	2
2.5 Durability Design Concepts	2
2.6 Damage Tolerance and Durability Design Procedures	3
3. DETAILED DAMAGE TOLERANCE REQUIREMENTS	4
3.1 Initial Flaw Size Assumptions	4
3.2 Flaw Growth and Damage Assumptions	4
3.3 In-Service Flaw Assumptions	5
3.4 Residual Strength Requirements	5
3.5 Specific Damage Tolerance Requirements	5
4. APPLICATION OF REQUIREMENTS TO EXISTING FLEET AIRCRAFT	7
4.1 Introduction	7
4.2 Fleet Assessment	8
4.3 Individual Aircraft Assessment	11
REFERENCES	
TABLES	
FIGURES	
DOCUMENT CONTROL DATA	
DISTRIBUTION	

Accession For	
NTIS GRA&I	<input checked="" type="checkbox"/>
DDC TAB	
Unannounced Justification	
By _____	
Distribution/	
Availability Codes	
Dist	Avail and/or special
A	

1. INTRODUCTION

Several years ago the USAF undertook an extensive review of the design requirements for military aircraft. The review was prompted by a number of severe service failures which had occurred in F-4, F-111 and F-5 aircraft. Many of the failures were due to fabrication defects or other pre-existing damage not considered in the initial design analysis. The assumption of a defect-free structure and the inadequate consideration of material property variations and environmental effects were held to be major shortcomings in the design specifications [1]. The aim of the review was to develop new specifications, based on fracture mechanics and non-destructive testing, which would be within the capabilities of the aircraft industry. The concept of an 'economic life' was introduced and the specifications were broadened to meet the requirements of the military services for aircraft of greater all-round durability. Improved standards of strength, safety and durability were incorporated and the result was a comprehensive and consistent policy now documented in various US military standards and specifications.

The essence of the new approach is the introduction of a 'damage-tolerant' design philosophy which recognizes the possible presence of defects and offers significant improvements in safety and reliability. These improvements result largely from the elimination of so-called 'critical areas' present in the structure of traditionally designed aircraft (see Section 4). Although much experience has still to be gained, damage-tolerant design concepts have now been adopted by the US military aircraft industry and the new specifications have been successfully employed in the design and development of the most recent USAF aircraft (A-10, B-1, F-15, F-16, etc.). In addition, a number of older service aircraft are being assessed, either in full or part, using the new concepts. The main purpose of these assessments is to provide a basis for improved life estimation procedures and life extension plans. According to some predictions all USAF operational aircraft will eventually be assessed and re-evaluated using damage tolerance and durability concepts.

The purpose of the present paper is to outline the basic damage tolerance and durability concepts and to summarise the main requirements used in the design of new aircraft. Some discussion is included concerning the application of these requirements to existing fleet aircraft, since these aspects are particularly relevant to Australian Defence requirements.

2. STRUCTURAL INTEGRITY AND GENERAL REQUIREMENTS FOR DAMAGE TOLERANCE AND DURABILITY

The requirements appearing in this Section are specified in MIL-STD-1530A [2].

2.1 Structural Integrity

The new concepts are being introduced into the design of new USAF aircraft through the Aircraft Structural Integrity Program (ASIP). The Program is intended to provide new aircraft with the required structural characteristics together with a minimum guaranteed economic life. Four main factors are considered to be important in determining the structural integrity of the aircraft:

1. Airframe Strength
2. Rigidity
3. Damage Tolerance, and
4. Durability.

The ASIP functions by evaluating these factors during the design and development of the aircraft, so that progressive comparisons can be made with the design objectives. Emphasis is placed on the early detection and elimination of problems which could otherwise impair the

operational effectiveness of the aircraft and involve severe cost penalties. The detailed requirements of the ASIP are divided into five tasks, extending from the design stage to fleet management (Table 1). It is clear that the success of the ASIP, and thus the success of the new requirements, relies largely on the ability to specify service conditions (mission/environment spectra, etc.), comprehensively design to that specification, and maintain operation of the aircraft within the design envelope.

2.2 Definitions

2.2.1 Damage Tolerance

Damage tolerance is defined as the ability of the airframe to resist failure due to the presence of flaws, cracks or other damage for a specified period of service.

2.2.2 Durability

Durability is defined as the ability of the airframe to resist cracking (including stress-corrosion and hydrogen-induced cracking), corrosion, thermal degradation, delamination, wear, and the effects of foreign object damage (FOD) for a specified time.

An important aspect of the durability concept is that *time*-dependent (rather than *service*-dependent) deterioration processes occurring in the airframe (i.e. forms of corrosion, etc.) are acknowledged.

2.3 General Damage Tolerance and Durability Requirements

The new concepts place certain general requirements on the airframe. The airframe should incorporate materials, stress levels, and structural configurations which:

1. Allow routine in-service inspections.
2. Reduce the risk of aircraft loss due to the propagation of undetected cracks, flaws or other damage to an acceptable level.
3. Minimize deterioration due to cracking (including stress-corrosion and hydrogen-induced cracking), corrosion, delamination, wear and the effects of FOD.

2.4 Damage Tolerance Design Concepts

The damage tolerance design concepts are specified in MIL-A-83444 [3] (see Section 3) and apply only to *safety-of-flight** structure. The primary requirement is that structural designs be categorized into two general types:

(1) Failsafe

Where unstable crack propagation is locally contained using multiple load paths or crack arrest designs.

(2) Slow Crack Growth (SCG)

Where flaws or defects growing by slow crack growth processes can be tolerated, but cracks must not be permitted to attain a size for rapid unstable crack propagation.

Both designs assume the presence of undetected flaws or damage and must have specified residual strength levels throughout specified periods of service.

2.5 Durability Design Concepts

The durability design concepts are specified in MIL-A-8866 [4] and apply to the whole airframe, including safety-of-flight structure. The basic requirement is that the economic life be greater than the design service life for the particular operational requirements (as specified).

The aim is to minimize all degradation which would result in excessive maintenance or functional problems (e.g. fuel leakage, etc.).

The structure classification and the application of the new concepts are shown in Figure 1.

* Safety-of-flight structure is defined as that structure in which failure could cause direct loss of the aircraft, or in which failure, if it remained undetected, could result in loss of the aircraft.

2.6 Damage Tolerance and Durability Design Procedures

Procedures are included in the specifications to ensure that the final airframe design fully complies with damage tolerance and durability requirements. The main steps are:

2.6.1 Prepare Control Plans

The purpose of the plans is to identify and define the tasks required in producing a basic design that will comply with the specifications. Apart from damage tolerance and durability, a control plan is required for corrosion prevention (in accordance with MIL-STD-1568 [5]).

2.6.2 Prepare Detailed Analyses

These analyses must demonstrate that the detailed specifications will be fully met by the particular structural design.

Damage Tolerance Analysis:

Flight-by-flight stress/environment spectra (based on design load spectra and environment) should be used in crack growth analyses and verification tests. Calculations of critical flaw sizes, residual strengths, safe crack growth periods and inspection intervals are required. The effect of variability in fracture properties should be accounted for.

Durability Analysis:

Flight-by-flight stress/environment spectra should also be used in the durability analysis and verification tests. The analysis is required to account for cracks or damage leading to uneconomical functional problems, repair, etc. Manufacturing quality variations, material property variations and analytical uncertainties should also be considered. The analysis provides a basis for development of test load spectra used in design, development and full scale durability testing.

2.6.3 Perform Damage Tolerance and Durability Tests

Damage Tolerance Tests:

The tests, carried out in accordance with MIL-A-8867 [6] and MIL-A-83444, must demonstrate the damage tolerant design of safety-of-flight components or regions of components. Existing components and assemblies (used in development, full scale static and durability tests), should be employed where possible in the damage tolerance tests, but additional components and assemblies are to be fabricated for testing where necessary.

Durability Tests:

The tests, carried out in accordance with MIL-A-8867, consist of repeated applications of flight-by-flight design service load/environment spectra and since durability requirements apply to the whole airframe, emphasis is placed on full-scale testing. The objectives of the full-scale tests are to:

1. Demonstrate that the economic life is equal to or greater than the design service life.
2. Identify critical areas of the airframe not previously identified.
3. Provide a basis for establishing special inspection and modification requirements for fleet aircraft.

Importance is placed on the lead-time achieved in the durability program. One lifetime of testing should be completed before a production go-ahead decision is made; two lifetimes of testing should be completed before delivery of the first aircraft. The test program includes major inspections during testing, and tear-down inspections at the completion of testing. Structural problems encountered during testing should be fully interpreted and evaluated.

The minimum test duration is specified in MIL-A-8867. At the request of the USAF, testing may be continued for two additional lifetimes beyond the minimum requirement in order to determine life extension capabilities and life capability for severe service conditions.

A flow chart representing the main damage tolerance and durability design procedures is shown in Figure 2.

3. DETAILED DAMAGE TOLERANCE REQUIREMENTS

The damage tolerance requirements appearing below are specified in MIL-A-83444. Defects or flaws are assumed to be present *ab initio* in each element of the safety-of-flight structure. The main purpose of the specification is to impose limits on the minimum flaw sizes that may be assumed in the design or inspection of the structure. The limitations ensure that design flaw sizes are kept to realistic levels, within both inspection and manufacturing capabilities. Furthermore, the requirement for 'flawed strength' encourages the development and use of materials with both high strength and toughness (i.e. damage tolerant materials).

3.1 Initial Flaw Size Assumptions

Radius corner flaws (RCFs), 0.12 mm (0.005") deep are assumed to exist at each hole in every element of safety-of-flight structure.

In addition, each element is assumed to contain two major defects; one at the most critical (i.e. highly stressed) hole, and one at the most critical location other than a hole. The flaw sizes depend on whether the particular element is of SCG or fail safe design (see Fig. 3). The smaller permitted sizes in the fail safe case represent the benefit of a design where unstable fracture would be contained. Smaller flaw sizes may be approved only for SCG designs, and only if it can be demonstrated that all larger flaw sizes have at least 90% probability of detection at the 95% confidence level.

3.2 Flaw Growth and Damage Assumptions

3.2.1 Continuing Damage (SCG and Fail Safe Structures)

The specifications contain assumptions for design and analysis work which provide for continuing crack growth in cases where a primary crack terminates due to structural discontinuities or element failure. These are:

1. Where cracking originates at a fastener hole and terminates prior to member or element failure, the continuing damage assumed is a new 0.12 mm RCF, diametrically opposite the initial flaw (Fig. 4(a)).
2. Where cracking terminates due to member or element failure the continuing damage assumed is a 0.12 mm RCF in the most critical location on the remaining element or structure, or a semi-circular surface flaw (0.5/0.25 mm). In both cases, the incremental crack growth from the prior load history (Δa) must be added to the new flaw size (Fig. 4(b)).
3. Where cracking terminates at a fastener hole, the continuing damage assumed is a 0.12 mm RCF emanating from the diametrically opposite side of the hole. The incremental crack growth from the prior history must be added to the new flaw (Fig. 4(c)).

3.2.2 Remaining Structure Damage (Fail Safe Structure)

3.2.2.1 Fail Safe Multiple Load Path Structure

Multiple load path structures consist of segments whose main function is to contain damage. Following the failure of any one segment or load path the structure must remain functional. Damage assumed to exist in adjacent load paths subsequent to a load path failure is as specified below:

(1) Path Dependent Structure:

In this type of structure common sources of cracking may exist in adjacent panels (e.g. by having adjacent panels rivetted together). The damage is that specified in the initial flaw assumptions (Section 3.1), plus an amount of crack growth, Δa , resulting from prior history.

(2) Path Independent Structure:

In this structure no common source of cracking can be permitted in adjacent panels and damage is that specified in Section 3.2.1 (Pt. 2).

3.2.2.2 Fail Safe Crack Arrest Structure

The damage assumed depends on the particular form of crack arrest geometry. Primary damage is assumed to be total failure of the structure between the crack arrest points (i.e. tear-resistant straps, stringers, etc.).

Continuing damage assumed to be in adjacent structure is the same as specified in Section 3.2.1 (Pts. 2 and 3).

3.3 In-Service Flaw Assumptions

The in-service flaw assumptions specify the *smallest* flaw that can be assumed to exist after an inspection. A depot or base level inspection utilizes one or more selected NDI techniques such as penetrant, X-ray, ultrasonics, etc. (X-ray inspection alone is not considered capable of reliably detecting tight sub-critical cracks). All NDI must be in accordance with procedures specified in MIL-I-6870 [7] and associated specifications.

(1) Depot or Base Level Inspection:

(a) Inspection after Component Removal:

If the component is removed from the aircraft and completely inspected using the original NDI procedures then the initial assumed flaw sizes (Section 3.1, Fig. 3) are applicable.

(b) Inspection without Component or Fastener Removal:

The minimum assumed flaw sizes at holes and cutouts, and at other locations are shown in Figure 5. For other surface flaw shapes, flaw sizes with the same value of stress intensity factor are appropriate.

(2) Visual Inspection:

Where only close visual inspection (including visual aids) is possible, the minimum assumed crack size is a through-the-thickness crack, 50 mm in length.

(3) Non-Inspectable or Limited Access:

Where accessibility and other factors preclude close visual or NDI inspection then:

(a) SCG structure is considered non-inspectable.

(b) Fail safe structure is considered inspectable for major damage only.

3.4 Residual Strength Requirements

The residual strength required in a structural component is determined, in part, by the design loads, and further by the degree to which the component can be inspected for damage (i.e. by accessibility). Thus non-inspectable components are designed to withstand higher loads and readily inspectable components are designed for lower loads. The actual design loads (i.e., the minimum residual strengths) are based on the aircraft loading spectrum in the following manner:

Design Load (for inspection interval) = Max. Load occurring in M inspection intervals

where M , the magnification factor, is between 20 and 100, depending on the particular inspection interval.

Thus a margin of safety is provided by magnifying the inspection interval. For example, the magnification factor for single flight inspections is specified as 100, and thus the design load must exceed the maximum load occurring in 100 flights of typical load spectra. The basic load spectra for various manoeuvres and missions are specified in MIL-A-8866.

For fail safe structure there is an additional requirement to sustain a minimum load at the instant of load path fracture (i.e. during any load redistribution), as well as a requirement to sustain a residual strength over the specified inspection interval.

3.5 Specific Damage Tolerance Requirements

The specific requirements state the degrees of inspectability and frequencies of inspection that are appropriate for safety-of-flight structure. Six degrees of inspectability are identified as follows:

(1) *In-Flight Evident Inspectable:*

Applies to structure in which damage is immediately evident to the flight crew and the mission is discontinued.

(2) *Ground Evident Inspectable:*

Applies to structure in which damage is immediately obvious to ground personnel without specific inspection.

(3) *Walkaround Inspectable:*

Applies to structure in which damage is evident in a visual inspection of the aircraft exterior, without removal of access panels or doors.

(4) *Special Visual Inspectable:*

Applies to structure in which damage is revealed during a detailed visual inspection, including removal of panels and using simple visual aids.

(5) *Depot or Base Level Inspectable:*

Applies to structure in which damage is detected using one or more selected NDI procedures.

(6) *In-Service Non-Inspectable:*

Applies to structure in which either the required resolution or accessibility precludes detection by the above inspections.

3.5.1 Slow Crack Growth Structure

SCG structure may only be classified as depot or base level inspectable, or in-service non-inspectable. The inspection frequencies, unless otherwise specified, are:

1. Depot or Base Level Inspectable—once every one quarter of the design lifetime.
2. In-Service Non-Inspectable—at the end of one design lifetime.

If the structure is depot or base level inspectable then the damage existing in the structure after a service inspection is specified in Section 3.3. These flaws are not permitted to grow to cause failure due to the application of the design load* in *two* inspection intervals (Fig. 6(a)).

If not depot or base level inspectable (i.e. in-service non-inspectable) then the initial damage specified in Section 3.1 is assumed to exist. These flaws are not permitted to grow to cause failure due to the application of the design load in *two* design service lifetimes (Fig. 6(b)).

For in-service non-inspectable SCG structures the new requirements may appear to resemble those of the traditional safe life philosophy. In fact, the design safety factor of 2 lifetimes represents a 50% decrease over the commonly used design safety factor of 4 lifetimes for safe life design. However, this does not necessarily imply a reduction in safety since the assumptions of initial damage in the new requirements provide a greater confidence in the life of SCG structures.

3.5.2 Fail Safe Multiple Load Path Structure (FSMLP)

The degrees of inspectability and the inspection frequencies (unless otherwise specified) applicable to this structure are:

INSPECTABILITY	INSPECTION FREQUENCY
1. In-flight evident	once per flight
2. Ground evident	once per flight
3. Walkaround evident	once per 10 flights
4. Special visual	not more than once per year
5. Depot or base level	once per quarter lifetime

3.5.2.1 Intact FSMLP Structure (prior to a load path failure)

Certain requirements are specified for damage less than a load path failure. If the structure is depot or base level inspectable for sub-critical flaws then the in-service damage in Section 3.3 is assumed to exist. These flaws are not permitted to grow to cause failure due to the application of the design load in *one* inspection interval (Fig. 7(a)).

* All design loads depend on the inspection interval involved; see Section 3.4.

If not depot or base level inspectable then the damage specified in Section 3.1 is assumed to exist. These flaws are not permitted to grow to cause failure of the load path due to the application of the design load in *one* design lifetime (Fig. 7(b)).

3.5.2.2 Remaining FSMLP Structure (subsequent to a load path failure)

The structure must be able to withstand dynamic load redistribution as in Section 3.4 without loss of the aircraft. In addition, the failed load path plus damage assumed in Section 3.2.2.1 are not permitted to grow to cause loss of the aircraft due to the application of the design load, within a specified period of service (Fig. 7(c)).

3.5.3 Fail Safe Crack Arrest Structure (FSCA)

The degrees of inspectability and frequencies of inspection for FSCA structures are the same as those specified for FSMLP structures.

3.5.3.1 Intact FSCA Structure (prior to crack growth and arrest)

If the structure is depot or base level inspectable for sub-critical flaws then the smallest flaws that can be assumed to exist are the in-service flaws in Section 3.3. These flaws are not permitted to grow to cause unstable crack growth due to the application of the design load in *one* inspection interval (Fig. 7(a)).

If not depot or base level inspectable then the initial damage specified in Section 3.1 is assumed to exist. These flaws are not permitted to grow to cause unstable cracking due to the application of the design limit load in *one* design lifetime (Fig. 7(b)).

3.5.3.2 Remaining FSCA Structure (subsequent to unstable crack growth and arrest)

The structure must be able to withstand the dynamic load redistribution in Section 3.4 without loss of the aircraft. In addition, after crack growth and arrest, remaining structure damage as specified in Section 3.2.2.2 is not permitted to grow to cause loss of the aircraft due to the application of the design load within a specified period of service (Fig. 7(c)).

As shown above the in-service flaw assumptions for fail safe structure are generally similar to those of SCG structures. The main benefit obtained in fail safe designs is a relaxation in inspection requirement. In SCG structures the design load must be maintained for two inspection intervals (for depot or base level inspectable and in-service non-inspectable structure), but this is reduced to one interval for fail safe structures.

4. APPLICATION OF REQUIREMENTS TO EXISTING FLEET AIRCRAFT

4.1 Introduction

The new Aircraft Structural Integrity Program (Section 2) is regarded by the USAF as an important advance in the design of military aircraft. A number of recent papers (e.g., References [8-12]) have discussed damage tolerance concepts in relation to new aircraft. However, there has also been considerable interest in the application of the concepts to existing service aircraft designed to meet traditional (safe life) requirements. In many cases these aircraft are now considered to be of uncertain structural integrity because the original design analysis did not adequately account for damage tolerance and durability factors. For example, the traditional approach does not contain a requirement to design for crack growth from a flaw, or to base inspection intervals on safe crack growth limits. Similarly, durability is uncertain because deterioration and repair have not been evaluated. Moreover, no specific determination of the economic life of the airframe has been made.

To offset these deficiencies the USAF has initiated damage tolerance and durability assessments for a number of service aircraft. At this stage at least five aircraft have been assessed (C-5A, F-4C/D, F-4E, A-7D and C-141A), and at least fifteen other aircraft, including trainers,

fighters and transports, are currently being assessed [13]. Among the assessments recently completed are those for the F-5E/F twin-engined fighter, for which the service life estimate has now been extended from 4000 hrs to 8000 hrs [14]. The main aims of these assessments are:

(a) *Damage Tolerance Assessment:*

To Determine:

1. Damage tolerance in critical areas of the airframe (i.e. where failure would severely affect the safety of the aircraft).
2. Safe crack growth limits and the inspection intervals based on appropriate crack growth rates.
3. Non-destructive inspection procedures required and the costs involved in inspections.
4. Modification and repair requirements for critical areas of the structure, including inspection requirements for repaired or modified areas.

(b) *Durability Assessment:*

To Determine:

1. Durability critical areas of the airframe (i.e. where failure or damage would involve severe economic penalties).
2. The economic life of the airframe when subjected to the design load/environment spectra (the economic life is the stage where damage, which is uneconomical to repair, would begin to cause functional and operational problems).
3. Maintenance, repair and modification procedures for the airframe and factors affecting these procedures, including environment and material property variations.

The detailed aims depend not only on aircraft type, but also on the in-service record and period of service prior to commencement of the assessments. To satisfactorily perform the assessments, a considerable amount of basic test data is required. This is generally provided by the testing programs associated with the original design work together with programs of additional testing and verification carried out at the time of the assessment. In some cases handbook data may be relied on.

The damage tolerance and durability assessments for USAF aircraft are generally performed under a contract lodged with the manufacturer of the particular aircraft. The assessment group consists of the manufacturer's engineers, familiar with the design details and test history, plus USAF engineers, familiar with the new requirements and the service history of the aircraft. Depending on the complexity of the airframe, assessments for whole aircraft may involve between 20 and 100 man-years effort [13].

4.2 Fleet Assessment

The fleet assessment consists of both damage tolerance and durability and is the basic assessment carried out on the aircraft. The primary assumption is that the aircraft will be operated within prescribed baseline load/environment spectra. The main input results required for damage tolerance assessment are:

4.2.1 Identification of Critical Areas

Large scale fatigue tests are required using load/environment spectra obtained from flight load analysis and in-service experience. The tests should incorporate appropriate high-resolution NDI procedures to assist in early identification of critical areas of the structure. Local stresses obtained by finite element methods such as NASTRAN (NASA Structural Analysis Program) should be verified by strain gauge data.

Only the areas of the structure where failure would jeopardize the safety of the aircraft can be classified as damage tolerance critical areas. To qualify as a major critical area, at least one of the following conditions must also be satisfied:

1. The area identified is non-inspectable for slow crack growth (i.e. not depot or base level inspectable) or,
2. The critical crack size is found to be below acceptable damage tolerance requirements (Section 3) or,
3. Crack growth significantly exceeds damage tolerance allowances (Section 3.5.1), causing inspection intervals to be reduced.

As might be expected, many areas of the structure are semi-critical (e.g. causing operational malfunctions, etc.) and a prudent evaluation is required. Fail safe areas of the multiple load path or crack arrest type are classified as non-critical. Typically, 100-300 critical areas are identified per aircraft, depending largely on aircraft size. However, further evaluation and grading of the critical areas may be required during the assessment.

4.2.2 Post-Test Analysis of Critical Areas

A detailed post-test analysis of the critical areas of the structure is required. This normally involves fractographic studies together with computer analyses in order to obtain rates of crack growth. These rates should be verified as far as possible by the NDI measurements made during the large scale tests.

Generally it is desirable to independently confirm the measured rates of crack growth by computer modelling. One of the difficulties is to obtain da/dn (or da/dt) data which can be considered accurate for the prescribed baseline load/environment spectra. Often a separate fatigue test program is required to generate basic da/dn data, which is then used to correlate cracking in the various critical areas of the aircraft. In performing such correlations, procedures such as the Willenborg or Wheeler model are used to describe spectrum retardation effects.

4.2.3 Initial Flaw Distribution

The influence of the initial flaw distribution on crack growth in the critical areas is required. This involves statistical analyses of positional and size distributions of flaws in critical components. Reference is usually made to the manufacturer's quality control standards. The growth of the initial flaw into a crack should be considered. Often this involves large changes in crack shape; a recent study indicating some analytical difficulties is given in Reference [12].

Some of the main studies used to identify and examine flaws in components are:

1. Studies of flaws and fastener hole finish in intact components, using NDI, metallographic techniques, etc.
2. Detailed fractographic studies of origins of cracking to identify initial flaw characteristics.
3. Computer studies of fracture surfaces which use 'reverse cracking' procedures to obtain information about the probable initial flaw size.

The effects of baseline operating environments and material variability on crack initiation and growth in the critical areas should also be determined.

4.2.4 Residual Strength

Values of residual strength are required for components in critical areas. Normally the plane strain fracture toughness (K_{IC}) would be used for thick sections, with appropriate corrections applied for thinner or intermediate sections where mixed mode fracture occurs. The effects of material variability on residual strength should be determined. An example of the magnitude of these effects is given in Reference [15].

In general, residual strength estimates would involve finite element stress analyses to account for non-standard loading and geometric effects. Computed strengths should be verified by tests on components from critical areas.

4.2.5 NDI Requirements

In the assessments, considerable importance is placed on the proven capabilities of various NDI techniques. This arises because some of the critical areas of traditionally designed aircraft have smaller than desirable critical crack sizes or undesirably rapid crack propagation rates. To reduce inspection frequencies to an economical level, reasonably large margins of allowable crack growth are required. Much of the success of the assessments seems to depend on whether or not these margins can be obtained with available NDI field detection capabilities. This problem is exemplified by recent assessments on the F-5 E/F [14] where it was concluded that cracks smaller than 5.0 mm in fastener-filled holes could not be reliably detected with existing NDI and operator capabilities. This detection capability imposes limitations on the assessments; a capability to detect smaller cracks in the range down to 0.5 mm would have enabled safety

limits on the aircraft to be considerably extended. The operation of NDI techniques under the constraints of field depot conditions should be considered as an important factor which can adversely affect detection capabilities. Clearly there is a need to improve NDI techniques and capabilities for use in future assessments.

Special attention must be paid to critical areas of the structure which are classified as non-inspectable. If the requirements for non-inspectable structures are not met then special NDI techniques may need to be developed to suit the particular structure. Alternatively, a form of structural modification or redesign may be necessary.

It should be noted that the damage tolerance requirements for new aircraft are intended to reduce or eliminate the dependence of flight safety on NDI capabilities. Under the new requirements, the maximum frequency for NDI is once per quarter design lifetime. Furthermore, the detection capabilities required are not particularly severe, thus enabling a choice of techniques.

4.2.6 Modification and Repair

Detailed modification and repair requirements for the critical areas must be established. The main requirements are:

1. The various stages in the life of the aircraft where modifications and repairs are required.
2. The options available at each modification or repair stage, including cost analyses.
3. The inspection requirements for modified or repaired structure.

The availability of this data at an early stage should reduce aircraft down-time, inspection requirements and servicing costs. It is particularly important to know just when to undertake various modifications and repairs, since penalties in cost and reliability could be involved.

A large part of the repair and modification work is associated with fastener systems. The fastener holes are sites for fatigue cracking and the standard repair is often some form of oversizing operation. However, USAF experience has shown that, due to the wide distribution in crack sizes, a small number of cracks often remain after an oversizing operation. To eliminate these cracks would require oversizing to be performed at an uneconomic time, much earlier in the life of the aircraft. A modification has therefore been developed by the Boeing Company in which the fastener holes are cold-worked to generate residual compressive stresses, thereby retarding the growth of any smaller cracks remaining after the oversizing operation. Compared with standard installation methods, this system is reported to increase total fatigue life by up to a factor of five, due apparently to a reduction in the effective initial flaw size [13, 14].

Repair or modification by reinforcement may also be required, usually as a cost-saving alternative to replacement of the part or local redesign. Techniques employed to correct large-scale problems include bracing and strengthening by the attachment of additional structure. Adhesively bonded metallic and fibre composite patches, fittings, etc., are widely used for local reinforcement. Radiusing, blending and other fine-scale material removal operations are employed for the repair of cracks and corrosion, and for fitting and misalignment problems.

Local redesign may be required to overcome severe structural or material deficiencies. Poor resistance to stress-corrosion cracking (e.g. 7079-T6 aluminium alloy), hydrogen embrittlement and corrosion fatigue (e.g. AISI 4340 and D6AC steels, in the ultra-high strength condition) are common problems. Poor fracture toughness and low resistance to fatigue crack propagation are further causes for material redesign. Major structural redesign is expensive and is seldom undertaken unless aircraft performance or safety is severely affected.

4.2.7 Final Analysis

Together with the main factors outlined above, a considerable amount of analysis and correlation work is required to complete the damage tolerance assessment. Each critical area is usually assigned an operational limit and an inspection interval before the aircraft is studied as a whole. Critical areas may then be graded according to the detailed consequences of failure. Special attention, perhaps involving modification or reinforcement, is given to problem areas where, for example, inspection at very short intervals would be required. Before the final operational limits and inspection intervals are set, consideration must also be given to the durability assessment and the particular requirements in the durability critical areas. Baseline fleet maintenance plans are then developed from these considerations.

4.3 Individual Aircraft Assessment

This assessment is a modification of the fleet assessment to allow for deviations from baseline operation in individual aircraft or in small groups of aircraft. The main factors considered are:

1. Different combinations of flight missions (i.e. air-to-air combat, air-to-ground combat, combat training, etc.).
2. Differences in the load severity for the same type of flight mission (e.g. from base-to-base, or country-to-country).
3. Variations in the operating environment (e.g. naval or air force use).

The assessments rely on recorded flight load data obtained from operational aircraft. However, the usual load exceedance data are generally insufficient to satisfactorily define flight loads and additional flight parameter measurements are required. In the case of the USAF/USN F-5 E/F [14], about 20% of the fleet are fitted with sophisticated multi-channel recorders to supply the necessary supplementary data. For these aircraft, the data are statistically processed to give averaged flight loads for each mission and operating base.

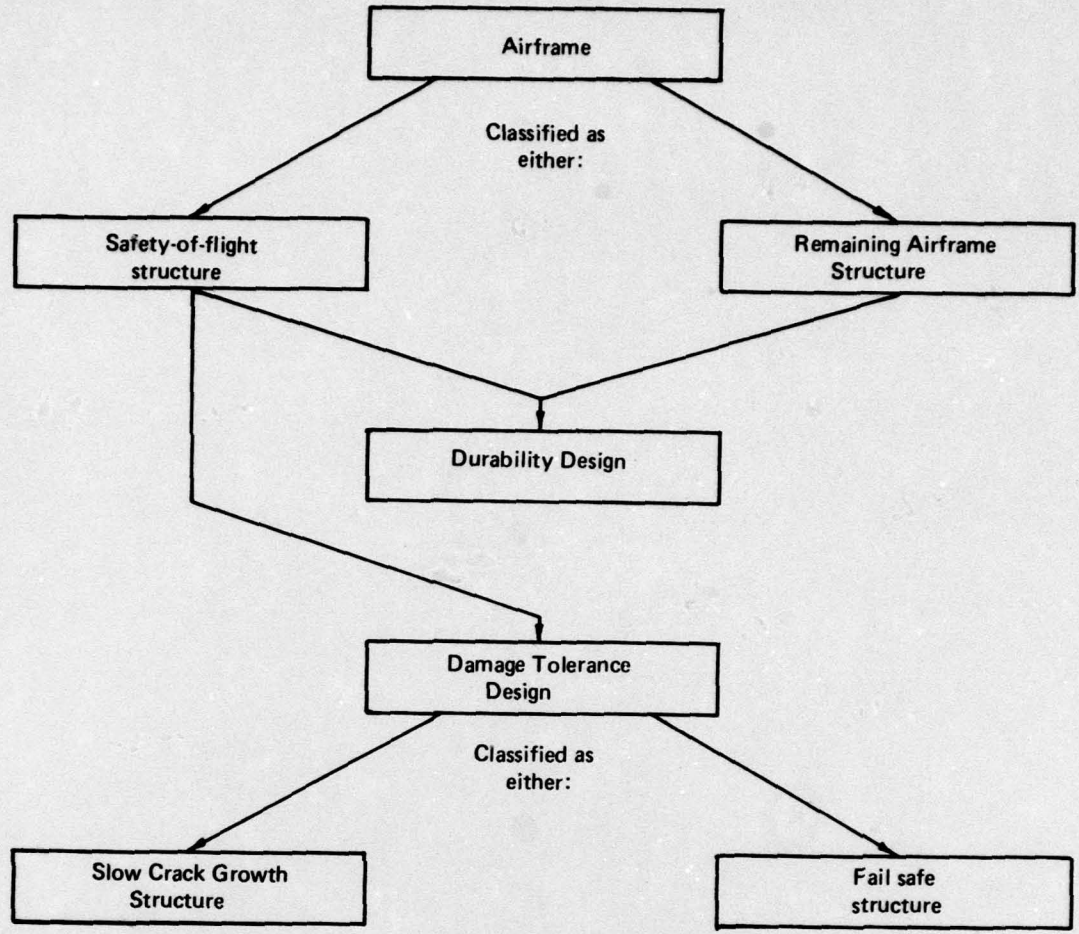
The effects of flight loads on crack growth rates in the critical areas are determined by computer analysis. Finite element models enable stresses within the various critical areas to be correlated for different sets of flight load conditions. Also, USAF experience with the F-4 [13] has shown that once crack growth in one area is analysed, then simple scaling can be used to provide a useful measure of the relative damage in other critical areas. Finally, the severity of damage in each critical area, for each flight load condition, is related to the limit set under the baseline operating condition.

REFERENCES

1. Coffin, M. D., and Tiffany, C. F.—*J. Aircraft*, **13**, Feb. 1976, pp. 93-98.
2. Military Standard, MIL-STD-1530 A (11).—*Aircraft Structural Integrity Program, Airplane Requirements*, USAF, 1975.
3. Military Specification, MIL-A-83444.—*Airplane Damage Tolerance Requirements*, USAF, 1974.
4. Military Specification, MIL-A-8866B.—*Airplane Strength and Rigidity, Reliability Requirements, Repeated Loads and Fatigue*, USAF, 1975.
5. Military Standard, MIL-STD-1568.—*Materials and Processes for Corrosion Prevention and Control in Aerospace Weapons Systems*, USAF, 1975.
6. Military Specification, MIL-A-8867B.—*Airplane Strength and Rigidity, Ground Tests*, USAF, 1975.
7. Military Specification, MIL-I-6870C.—*Inspection Program Requirements, Non-destructive, for Aircraft and Missile Materials and Parts*, USAF, 1973.
8. McHenry, H. I., and Hensley, E. K.—*J. Aircraft*, **12**, Feb. 1975, pp. 93-99.
9. Wood, H. A.—*Eng. Frac. Mech.*, **7**, 1975, pp. 557-564.
10. Kaplan, M. P., and Reiman, J. A.—*J. Aircraft*, **13**, Feb. 1976, pp. 99-103.
11. Hoepfner, D. W., Krupp, W., and Pettit, D.—*ibid.*, **14**, Nov. 1977, pp. 1070-1075.
12. Pike, V. J., and King, W. T.—*R.A.E. Tech. Rpt. No. TR77026*, 1977.
13. Tiffany, C. F.—'Durability and Damage Tolerance Assessments of USAF Aircraft', in Notebook on 'Analysis of USAF Aircraft—Structural Durability and Damage Tolerance' by C. F. Tiffany et al., Aeronautical Systems Divn., USAF.
14. Murnane, S. R., Voorhees, L. F., and Davenport, O. B.—In 'Fracture Mechanics', ed. N. Perrone et al., Univ. Press of Virginia, 1978, pp. 17-42.
15. Schultz, W.—*Proc. AGARD Conf. (C.P. 221) on 'Fracture Mechanics Design Methodology'*, London, Sept. 1976.

TABLE 1
USAF Aircraft Structural Integrity Program Tasks [2]

TASK I	TASK II	TASK III	TASK IV	TASK V
Design Information	Design Analyses and Development Tests	Full Scale Testing	Fleet Management Data Package	Fleet Management
ASIP Master Plan	Materials and Joint Allowables	Static Tests	Final Analyses	Loads/Environment Spectra Survey
	Load Analysis	Durability Tests	Strength Summary	
Structural Design Criteria	Design Service Loads Spectra			Individual Aircraft Tracking Data
	Design Chemical/Thermal Environment Spectra	Damage Tolerance Tests	Fleet Structural Maintenance Plan	
Damage Tolerance & Durability Plans	Stress Analysis			Individual Aircraft Maintenance Times
	Damage Tolerance Analysis	Flight & Ground Operations Tests	Loads/Environment Spectra Survey	
Selection of Materials, Processes, and Joining Methods	Durability Analysis	Sonic Tests	Individual Aircraft Tracking Program	Structural Maintenance Records
	Sonic Analysis			
	Vibration Analysis	Flight Vibration Tests		
Design Service Life and Design Usage	Flutter Analysis			
	Nuclear Weapons Effects Analysis	Flutter Tests		
	Non-Nuclear Weapons Effects Analysis			
	Design Development Tests	Interpretation & Evaluation of Test Results		



All single load path structure without crack arrest features plus Multiple load path structure or crack arrest structure where inspectability level invalidates fail safe requirements.

Multiple load path or crack arrest structure

FIG. 1. STRUCTURE CLASSIFICATION AND DAMAGE TOLERANCE AND DURABILITY DESIGN CONCEPTS.

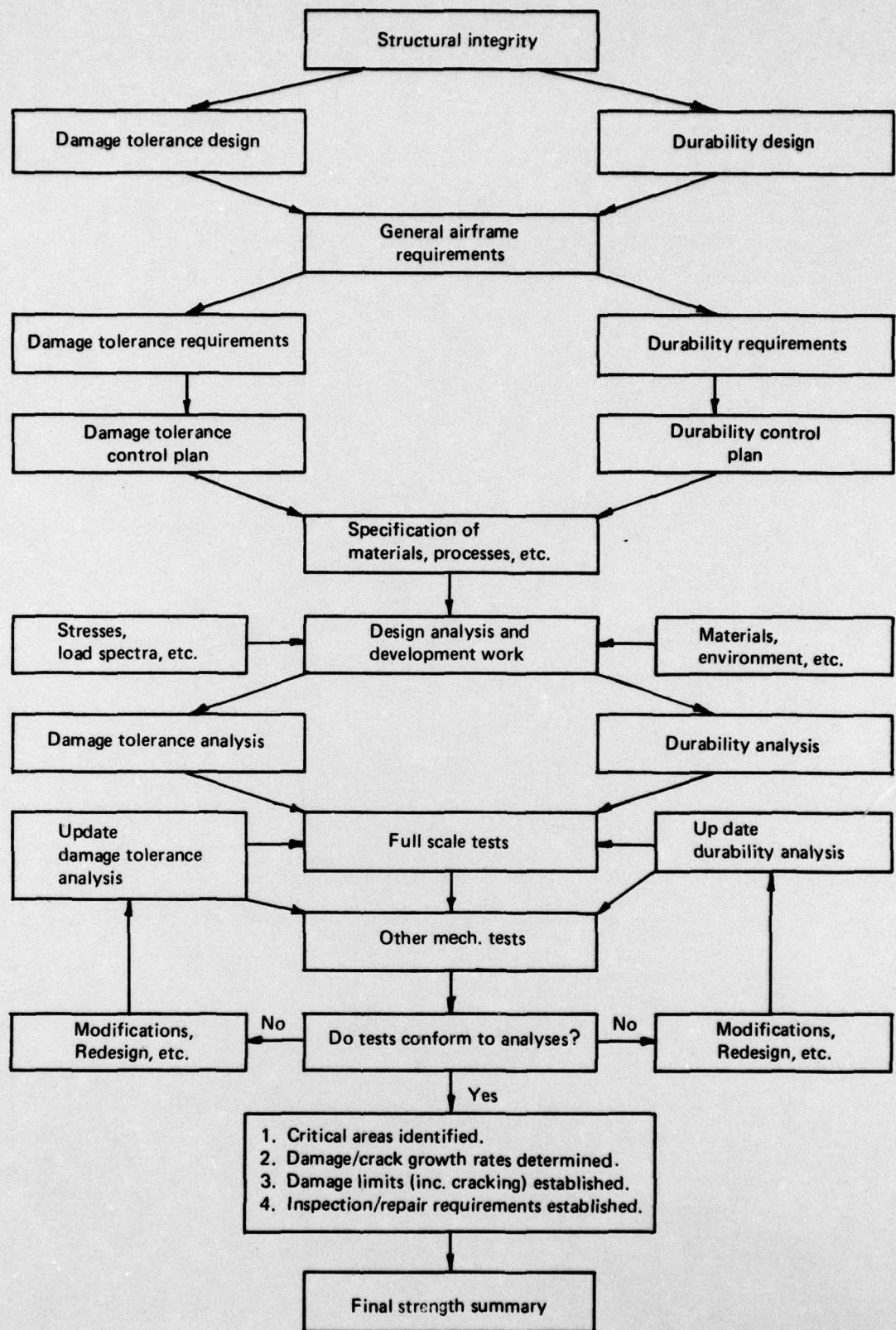
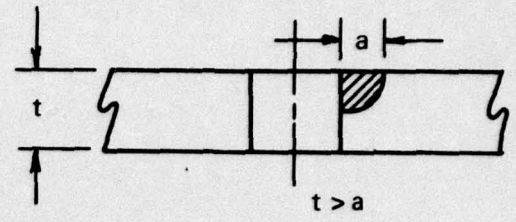
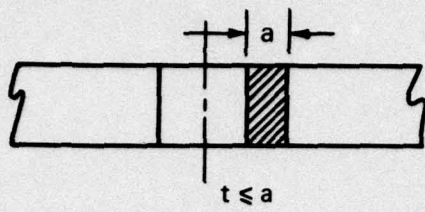
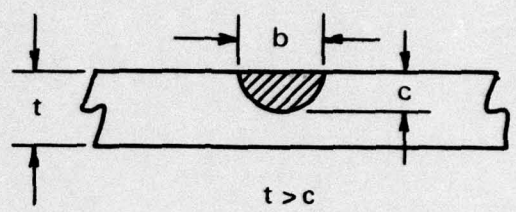
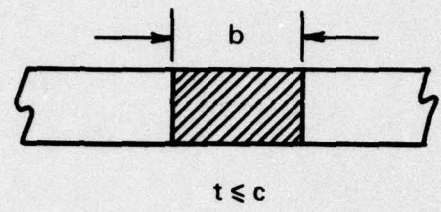


FIG. 2. FLOW CHART OF DAMAGE TOLERANCE AND DURABILITY DESIGN PROCEDURES.



At holes and cutouts



At locations other than holes

(i) One radius corner flaw, 0.12 mm deep, at every hole, plus

(ii) Two major flaws, one at holes and cutouts and one at locations other than holes:

	SCG (mm)	Fail safe (mm)
a	1.3	0.5
b	6.4	2.5
c	3.2	1.3

FIG. 3. INITIAL FLAW ASSUMPTIONS.

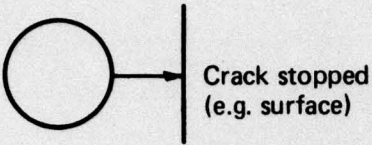
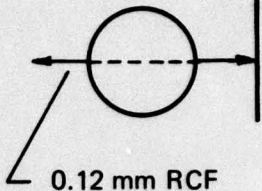
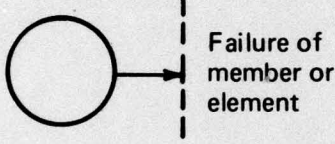
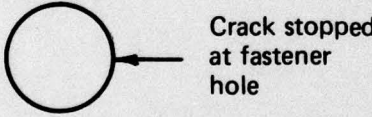
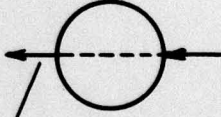
Terminating damage	Continuing damage
<p>(a)</p>  <p>Crack stopped (e.g. surface)</p>	 <p>0.12 mm RCF</p>
<p>(b)</p>  <p>Failure of member or element</p>	<p>0.12 mm RCF in most critical location or semi-circular surface flaw (0.5/0.25 mm)</p> <p>Plus</p> <p>Crack growth due to prior history</p>
<p>(c)</p>  <p>Crack stopped at fastener hole</p>	 <p>0.12 mm RCF plus crack growth due to prior history</p>

FIG. 4. CONTINUING DAMAGE ASSUMPTIONS.

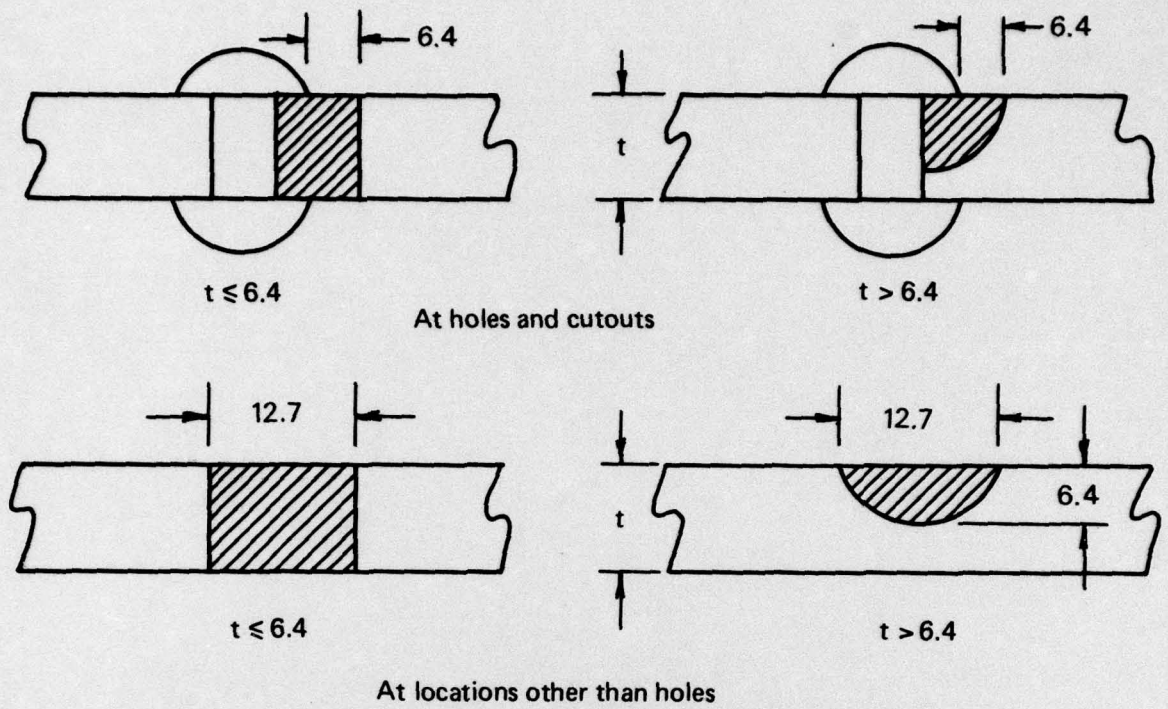
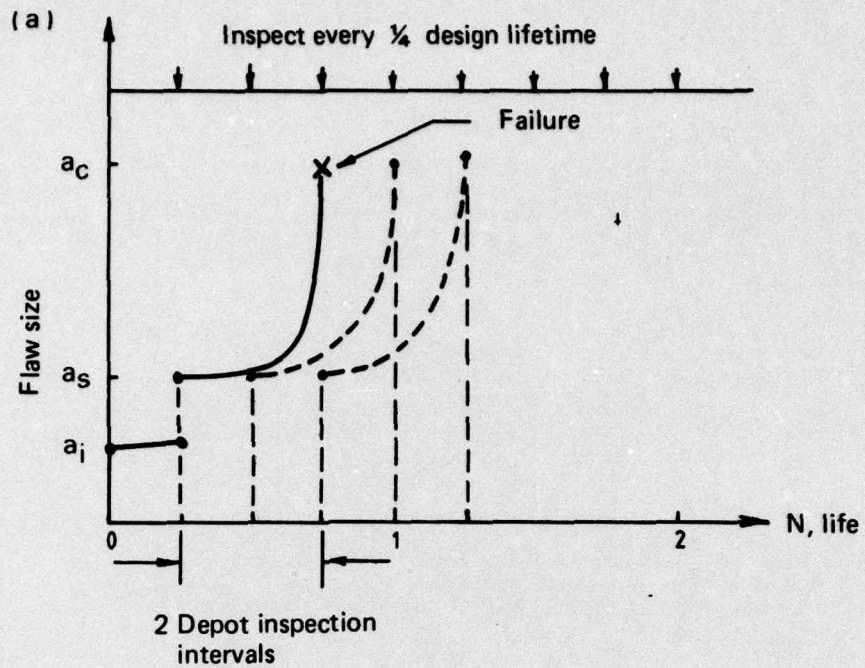


FIG. 5. FLAW SIZE ASSUMPTIONS FOR IN-SERVICE INSPECTIONS. DIMENSIONS ARE IN MM.



a_i — initial flaw size
 a_s — in-service flaw size
 a_c — critical flaw size

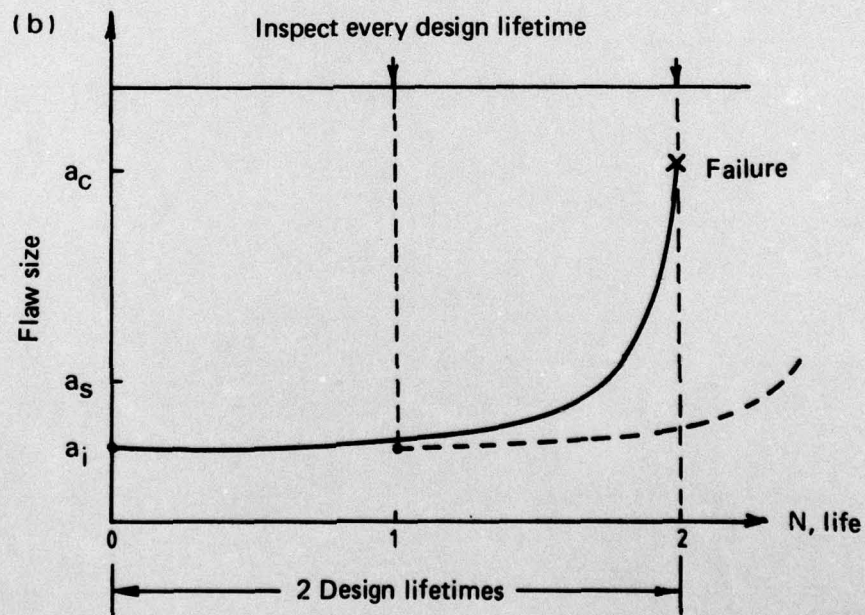


FIG. 6. SAFE CRACK GROWTH AND INSPECTION REQUIREMENTS FOR SLOW CRACK GROWTH STRUCTURE:
 (a) depot or base level inspectable, and
 (b) in-service non-inspectable.

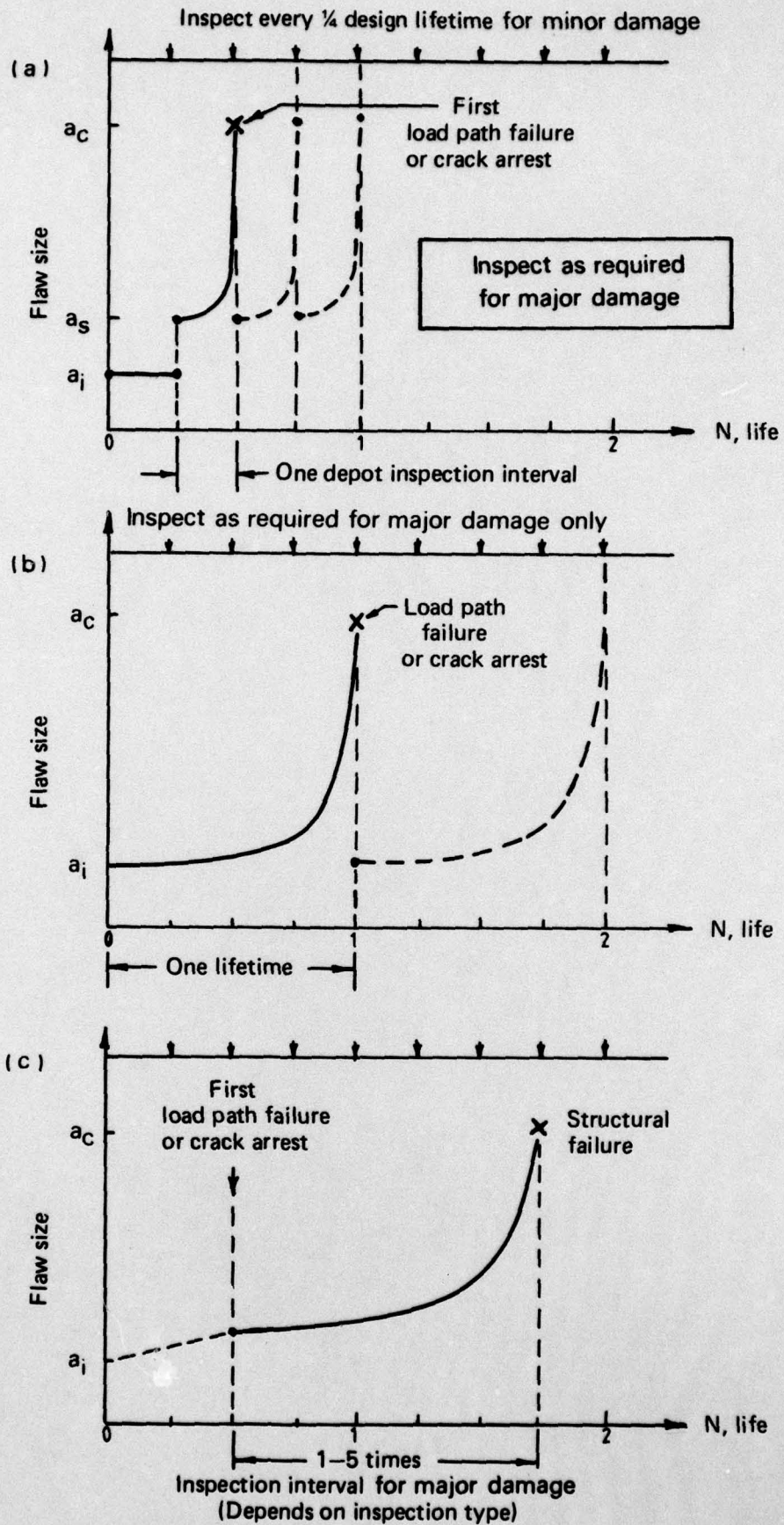


FIG. 7. SAFE CRACK GROWTH AND INSPECTION REQUIREMENTS FOR FAIL SAFE STRUCTURE:

- (a) depot or base level inspectable,
- (b) inspectable for major damage only, and
- (c) subsequent to load path failure or crack arrest.

DOCUMENT CONTROL DATA SHEET

Security classification of this page: Unclassified

<p>1. Document Numbers (a) AR Number: AR-001-344 (b) Document Series and Number: Materials Note 599 (c) Report Number: ARL-Mat-Note-126</p>	<p>2. Security Classification (a) Complete document: Unclassified (b) Title in isolation: Unclassified (c) Summary in isolation: Unclassified</p>									
<p>3. Title: A SUMMARY OF DAMAGE TOLERANCE SPECIFICATIONS WITH EMPHASIS ON MATERIALS AND NDI REQUIREMENTS</p>										
<p>4. Personal Author(s): J. Q. Clayton</p>	<p>5. Document Date: February, 1979</p>									
<p>6. Type of Report and Period Covered:</p>										
<p>7. Corporate Author(s): Aeronautical Research Laboratories</p>	<p>8. Reference Numbers (a) Task: 72/08 (b) Sponsoring Agency: AIR</p>									
<p>9. Cost Code: 33 1610</p>	<p>11. Computer Program(s) (Title(s) and language(s)):</p>									
<p>10. Imprint Aeronautical Research Laboratories, Melbourne</p>										
<p>12. Release Limitations (of the document) Approved for Public Release</p>										
<table border="1" style="width: 100%; border-collapse: collapse;"> <tr> <td style="width: 25%;">12-0. Overseas:</td> <td style="width: 5%;">N.O.</td> <td style="width: 5%;">P.R.</td> <td style="width: 5%;">I</td> <td style="width: 5%;">A</td> <td style="width: 5%;">B</td> <td style="width: 5%;">C</td> <td style="width: 5%;">D</td> <td style="width: 5%;">E</td> </tr> </table>		12-0. Overseas:	N.O.	P.R.	I	A	B	C	D	E
12-0. Overseas:	N.O.	P.R.	I	A	B	C	D	E		
<p>13. Announcement Limitations (of the information on this page): No Limitation</p>										
<p>14. Descriptors: Design standards Military aircraft Service life Crack propagation</p>	<p>15. Cosati Codes: Nondestructive tests 0103 Airframe materials 1113 Aircraft reliability Aircraft safety</p>									

16. *ABSTRACT*

Specifications for USAF military aircraft now include damage tolerance and durability as basic structural requirements. The introduction of these requirements into the design and development of future aircraft is briefly described.

The new design analysis assumes the existence of flaws in the structure and considers their growth, at calculable rates, by appropriate cracking processes. Non-destructive inspection (NDI) intervals are then specified according to limits of safe crack growth. Airframe rework and repair requirements are similarly established for a period greater than the design life. Details of damage tolerance requirements, including flaw size assumptions, NDI intervals, etc., are summarized and illustrated.

Under the new requirements, many existing aircraft are considered to be of uncertain structural integrity. The USAF is currently assessing damage tolerance and durability on a wide range of service aircraft. Application of the new requirements and methods of assessing damage tolerance in operational aircraft are described.

DISTRIBUTION

Copy No.

AUSTRALIA

Department of Defence

Central Office

Chief Defence Scientist	1
Deputy Chief Defence Scientist	2
Superintendent, Science and Technology Programs	3
Australian Defence Scientific and Technical Representative (U.K.)	4
Counsellor, Defence Science (U.S.A.)	5
Defence Library	6
Joint Intelligence Organisation	7
Assistant Secretary, D.I.S.B.	8-23

Aeronautical Research Laboratories

Chief Superintendent	24
Library	25
Superintendent, Materials Division	26
Divisional File, Materials Division	27
Superintendent, Mechanical Engineering Division	28
Divisional File, Mechanical Engineering Division	29
Superintendent, Structures Division	30
Divisional File, Structures Division	31
Author: J. Q. Clayton	32

Materials Research Laboratories

Library	33
---------	----

Defence Research Centre, Salisbury

Library	34
---------	----

Central Studies Establishment

Information Centre	35
--------------------	----

Engineering Development Establishment

Library	36
---------	----

RAN Research Laboratory

Library	37
---------	----

Defence Regional Office

Library	38
---------	----

Navy Office

Navy Scientific Adviser	39
-------------------------	----

Army Office

Army Scientific Adviser	40
Royal Military College Library	41
US Army Standardisation Group	42

Air Force Office		
Aircraft Research and Development Unit		43
Air Force Scientific Adviser		44
Engineering (CAFTS) Library		45
D. Air Eng.-AF		46
HQ Support Command (SENGSO)		47
RAAF Academy Point Cook		48
Department of Productivity		
Government Aircraft Factories		
Manager/Library		49
Department of National Resources		
Secretary		50
Department of Transport		
Secretary/Library		51
Airworthiness Group, Mr K. O'Brien		52
Statutory, State Authorities and Industry		
CSIRO Mechanical Engineering Division, Chief		53
CSIRO Materials Science Division, Director		54
Qantas, Library		55
Trans Australia Airlines, Library		56
BHP Melbourne Research Laboratories		57
Commonwealth Aircraft Corporation, Manager		58
Commonwealth Aircraft Corporation, Manager of Engineering		59
Hawker de Havilland Pty Ltd, Librarian, Bankstown		60
Hawker de Havilland Pty Ltd, Manager, Lidcombe		61
Rolls Royce of Australia Pty Ltd, Mr Mosley		62
Ansett Airlines of Australia, Library		63
Universities and Colleges		
Adelaide	Barr Smith Library	64
Australian National	Library	65
Flinders	Library	66
James Cook	Library	67
La Trobe	Library	68
Melbourne	Engineering Library	69
Monash	Library	70
Newcastle	Library	71
New England	Library	72
Sydney	Engineering Library	73
	Professor G. A. Bird	74
	The Head, School of Civil Engineering	75
	Professor R. I. Tanner	76
New South Wales	Professor R. A. A. Bryant	77
	Physical Sciences Library	78
	Assoc. Professor R. W. Traill-Nash	79
Queensland	Library	80
Tasmania	Engineering Library	81
Western Australia	Library	82
	Professor Allen-Williams	83
RMIT	Library	84
	Mr H. Millicer	85
	Mr Pugh, Mechanical Engineering	86

80