

AD-A078 803

PACIFIC MISSILE TEST CENTER POINT MUGU CA
MINICOMPUTER CONTROLLED SYSTEM FOR TESTING TELEMETRY RECEIVING --ETC(U)
OCT 79 E L LAW , G J HARBOLD
PMTc-TP-79-30

F/G 19/6

UNCLASSIFIED

NL

1 OF 1
AD
A078803



END
DATE
FILMED
1-80
DDC

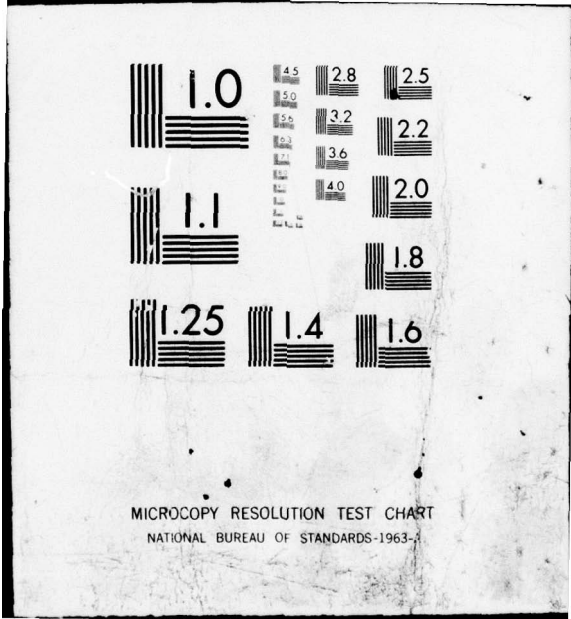



12
E

Technical Publication TP-79-30

LEVEL #

**MINICOMPUTER CONTROLLED SYSTEM FOR
TESTING TELEMETRY RECEIVING AND
RECORDING SYSTEMS**

(AIRTASK A6306302-054D-9W06040000)

By

E. L. LAW and G. J. HARBOLD, JR
Weapons Instrumentation Division

10 October 1979

DDC
RECEIVED
DEC 31 1979
RESERVED
A

APPROVED FOR PUBLIC RELEASE; DISTRIBUTION UNLIMITED.

PACIFIC MISSILE TEST CENTER

Point Mugu, California

79 12 31 030

ADA 078803

DDC FILE COPY



14 PMTC-TP-79-30

64208N

UNCLASSIFIED

SECURITY CLASSIFICATION OF THIS PAGE (When Data Entered)

REPORT DOCUMENTATION PAGE		READ INSTRUCTIONS BEFORE COMPLETING FORM
1. REPORT NUMBER TP-79-30	2. GOVT ACCESSION NO.	3. RECIPIENT'S CATALOG NUMBER
4. TITLE (and Subtitle) MINICOMPUTER CONTROLLED SYSTEM FOR TESTING TELEMETRY RECEIVING AND RECORDING SYSTEMS		5. TYPE OF REPORT & PERIOD COVERED
7. AUTHOR(s) E. L. Law and G. J. Harbold, Jr		6. PERFORMING ORG. REPORT NUMBER
9. PERFORMING ORGANIZATION NAME AND ADDRESS Pacific Missile Test Center Point Mugu, California 93042		8. CONTRACT OR GRANT NUMBER(s) 12 53
11. CONTROLLING OFFICE NAME AND ADDRESS Naval Air Systems Command Washington, DC 20361		10. PROGRAM ELEMENT, PROJECT, TASK AREA & WORK UNIT NUMBERS AIRTASK A6306302-054D-9W06040000
14. MONITORING AGENCY NAME & ADDRESS (if different from Controlling Office) 9 Technical publication		12. REPORT DATE 11 10 October 1979
16. DISTRIBUTION STATEMENT (of this Report) Approved for public release; distribution unlimited.		13. NUMBER OF PAGES 44
17. DISTRIBUTION STATEMENT (of the abstract entered in Block 20, if different from Report)		15. SECURITY CLASS. (of this report) UNCLASSIFIED
18. SUPPLEMENTARY NOTES		15a. DECLASSIFICATION/DOWNGRADING SCHEDULE
19. KEY WORDS (Continue on reverse side if necessary and identify by block number) Telemetry ground station testing Antenna figure-of-merit Noise power ratio (NPR) PCM tests Minicomputer controlled tests Automated test equipment Instrument interfacing		16 W0604
20. ABSTRACT (Continue on reverse side if necessary and identify by block number) This report describes a minicomputer controlled system for testing telemetry receiving and recording stations and presents sample test results. Details of the interface between the minicomputer and the test equipment are also presented. The system can test a telemetry receiving and recording station in about one/fifth the time it takes to manually test the station. The test results are printed out and can be stored on the computer for trend analysis and other statistical analyses. The system accuracy is ± 1.0 dB or better for all tests. The results of the various tests correlate well with each (Continued) → next page		

DD FORM 1473 1 JAN 73

EDITION OF 1 NOV 65 IS OBSOLETE

UNCLASSIFIED

SECURITY CLASSIFICATION OF THIS PAGE (When Data Entered)

+ or -

409 248

JOB

UNCLASSIFIED

SECURITY CLASSIFICATION OF THIS PAGE(When Data Entered)

20. ABSTRACT (Concluded)

other and with manually performed tests. It has been demonstrated that a minicomputer controlled system can perform a good, fast, accurate test on a telemetry receiving and recording station.

UNCLASSIFIED

SECURITY CLASSIFICATION OF THIS PAGE(When Data Entered)

ACKNOWLEDGMENT

The authors wish to express their gratitude to the people who helped make this project a success. Their technical expertise and cooperation were vital to this project. **Mr. D. A. King** designed most of the interfaces between the minicomputer and the test equipment. He also debugged the interfaces and was instrumental in the development of the various tests. **Mr. H. H. Mansnerus** designed the programmable amplifier. **Mr. R. A. Wallston** developed the operational SCATS software package. **Mr. D. H. Cronin** wrote the initial SCATS routines and the instrument drivers. **Mr. K. J. Clark** and **Mr. J. N. Mayo** performed the software modification necessary to get SCATS running on the operational site minicomputer. **Mr. W. L. Blayney**, **Mr. A. E. Hopwood**, and **Mr. C. L. Monroe** provided many helpful suggestions on ways to make the SCATS more useful for the checkout of operational telemetry ground stations. **Mr. E. M. De Jong** provided many useful ideas during the conceptual system design. **Mr. E. C. Nicholson** and **Mr. C. C. Nily** did an excellent job of wiring and constructing SCATS. **Mr. R. V. Moon** was in charge of moving SCATS from the laboratory to the operational ground station. **Mr. R. A. Reed** was in charge of coordination within the Range Directorate.

Accession For	
NTIS GRA&I	<input checked="" type="checkbox"/>
DDC TAB	<input type="checkbox"/>
Unannounced	<input type="checkbox"/>
Justification	
By _____	
Distribution/	
Availability Codes	
Dist.	Avall and/or special
A	

CONTENTS

	Page
SUMMARY	1
INTRODUCTION	3
SYSTEM DESCRIPTION	4
EQUIPMENT DESCRIPTION	6
Minicomputer and Peripherals	6
Interface Between Minicomputer and Test Equipment	6
RF Signal Generator, Telemetry Receiver, and Associated Equipment	6
BEP and NPR Test Equipment	7
Other Equipment	8
SCATS SOFTWARE	8
TEST PARAMETER ENTRY	9
ANTENNA FIGURE OF MERIT TEST	9
INTERMEDIATE FREQUENCY SNR TEST	16
PULSE CODE MODULATION BIT ERROR PROBABILITY TEST	18
NOISE POWER RATIO TEST	23
TAPE RECORDER FREQUENCY RESPONSE TEST	25
INSTRUMENT TESTS	25
CONCLUSIONS	26
RECOMMENDATIONS	26
REFERENCES	27
APPENDIX	
A. Interface Between Minicomputer and Test Equipment	A-1

CONTENTS (Concluded)

	Page
TABLES	
1. Antenna Solar Calibration Test Output	13
2. Antenna Solar Calibration, S-Band, Antenna 1	13
3. Antenna Solar Calibration, S-Band, Antenna 4	14
4. Antenna Solar Calibration, Lower L-Band, Antenna 4	14
5. Antenna Solar Calibration, Upper L-Band, Antenna 4	15
6. Solar Calibration Data Summary, S-Band, Antenna 4	15
7. Solar Calibration Means and Standard Deviations, 2250.5 MHz	16
8. SCATS IF SNR Test Output	17
9. IF SNR Repeatability	18
10. Comparison Between Results of IF SNR Test and G/T Test	18
11. Bit Error Probability Test Output	21
12. Comparison of IF SNR Calculated From BEP Test Results With IF SNR Calculated From Measured Noise Temperature	22
13. Noise Power Ratio Test Output (5 dB RF Power Steps)	24
14. Noise Power Ratio Test Results at Recorder/Reproducer Input	24
15. Noise Power Ratio Test Results at Recorder/Reproducer Output	25
16. Functional Noise Power Ratio Test Results (Back-to-Back Test)	25
17. SCATS TR FR Test Output	26
FIGURES	
1. SCATS Block Diagram	5
2. SCATS Log-In and Parameter Entry	10
3. Antenna Figure of Merit (G/T) Configuration	11
4. Antenna Figure of Merit (Solar Calibration) Data Entry	11
5. Receiving System Sensitivity Test (IF SNR) Configuration	16
6. Bit Error Probability Test Configuration	19
7. Bit Error Probability Test Data Entry	19
8. Bit Error Probability Versus IF SNR	21
9. Bit Error Probability Versus IF SNR for Several Bit Rate to IF BW Ratios	22
10. Noise Power Ratio (NPR) Test Configuration	23

TP-79-30
10 October 1979

PACIFIC MISSILE TEST CENTER
Point Mugu, California 93042

MINICOMPUTER CONTROLLED SYSTEM FOR TESTING
TELEMETRY RECEIVING AND RECORDING SYSTEMS

(AIRTASK A6306302-054D-9W06040000)

By
E. L. LAW and G. J. HARBOLD, JR.

SUMMARY

This report describes a minicomputer controlled system for testing telemetry receiving and recording stations. Self-Check Automated Telemetry System (SCATS) can test a telemetry receiving and recording station in about one-fifth the time it takes to manually test the station. The test results are printed out and can be stored on the computer for trend analysis and other statistical analyses. The SCATS accuracy is ± 1.0 dB or better for all tests. The results of the various tests correlate well with each other and with manually performed tests. It has been demonstrated that a minicomputer controlled system such as SCATS can perform a good, fast, accurate test on a telemetry receiving and recording station.

Publication UNCLASSIFIED.

Approved for public release; distribution unlimited.

INTRODUCTION

This report describes a minicomputer controlled system for testing telemetry receiving and recording stations. This system is called the Self-Check Automated Telemetry System (SCATS). SCATS is also a prototype telemetry receiving and recording station. SCATS uses the standard Inter-Range Instrumentation Group (IRIG) document number 118 tests. The tests implemented are:

1. Antenna figure of merit (gain/temperature (G/T))
2. Intermediate frequency (IF) signal-to-noise ratio (SNR)
3. Bit error probability (BEP)
4. Noise power ratio (NPR)
5. Tape recorder frequency response

SCATS performs the first two tests using the SCATS computer controlled receiver but can perform the last three tests on any manually controlled receiver and/or recorder/reproducer.

SCATS can also be patched to test one of the Pacific Missile Test Center's operational telemetry ground stations. The operational telemetry ground station has four dual-polarization, 32-foot dish, tracking antennas; 24 dual-channel telemetry receivers with built-in combiners; and 12 analog magnetic tape recorders. Radio frequency (RF) signals can be inserted into the preamplifier inputs of the antennas. The antenna outputs can be patched to either the SCATS receiver or the ground station receivers. The receiver outputs can be patched to either the tape recorders or the SCATS data inputs. The tape recorder outputs can be patched to the SCATS data inputs. SCATS accepts video signals and 450- and 900-kHz frequency modulated predetection carrier signals as inputs.

The use of a computer controlled system to test telemetry ground stations has the following advantages:

1. Test results are more repeatable because the operator is not in the set-up, adjustment, and meter reading loop and the computer does the same things each time.
2. Tests take much less time to perform, which is very important in a busy ground station.
3. A quick, accurate test can be run immediately before a mission, which will increase the probability of receiving and recording good data during the mission.
4. The tests are easy to do; this makes it more likely that they will be done.
5. Test results can be stored and also recalled for comparisons between tests run under the same conditions.

The disadvantage of a computer-controlled test system is the higher initial cost. This should be more than offset by the overall improved data quality, problem detection capability, and decreased down-time for testing.

The work reported herein was conducted under AIRTASKS: A5355352-054D-5W47410030, A06R06R1-054D-6WSL770000, A6306302-054D-7WSL770000, A6306302-054D-8W06040000, and A6306302-054D-9W06040000, Missile Flight Evaluation Systems, and was jointly funded by the Naval Air Systems Command and the Pacific Missile Test Center.

SYSTEM DESCRIPTION

A simplified block diagram of SCATS is presented in figure 1. SCATS contains the following equipment:

1. Minicomputer with 16K of core memory, 48K semiconductor memory.
2. Two 5-Megabyte disk drives plus one dual floppy disk drive (250 Kilobytes each drive).
3. Typewriter terminal plus CRT terminal.
- *4. Interface between minicomputer and test equipment.
5. Radio frequency signal generator, L- and S-band, 1 dB step attenuator, frequency, and phase modulation (FM and PM).
6. Frequency synthesizer.
7. RF power meter.
8. RF counter.
- *9. RF distribution unit.
10. Dual-channel telemetry receiver with synthesized tuner.
11. Diversity combiner.
- *12. Predetection discriminators (450- and 900-kHz).
- *13. Programmable gain amplifier.
14. Pulse code modulation (PCM) test set.
15. Noise generator and receiver (for NPR test).
16. RMS meter.
17. Function generator.
18. Counter.
19. Ten discrete relays and two 10 x 10 matrices.
- *20. Controller for amplifier, relays, and matrices.
21. PCM bit synchronizer.
22. S-band to P-band down converter.
23. Oscilloscope (not under computer control).
24. RF spectrum analyzer (not under computer control).

The RF distribution unit, the discrete relays, and the matrices are used to interconnect the SCATS equipment and also to connect the SCATS equipment with the operational telemetry ground station.

* Indicate equipment designed and built by Pacific Missile Test Center (PACMISTESTCEN); all other equipment is commercially available.

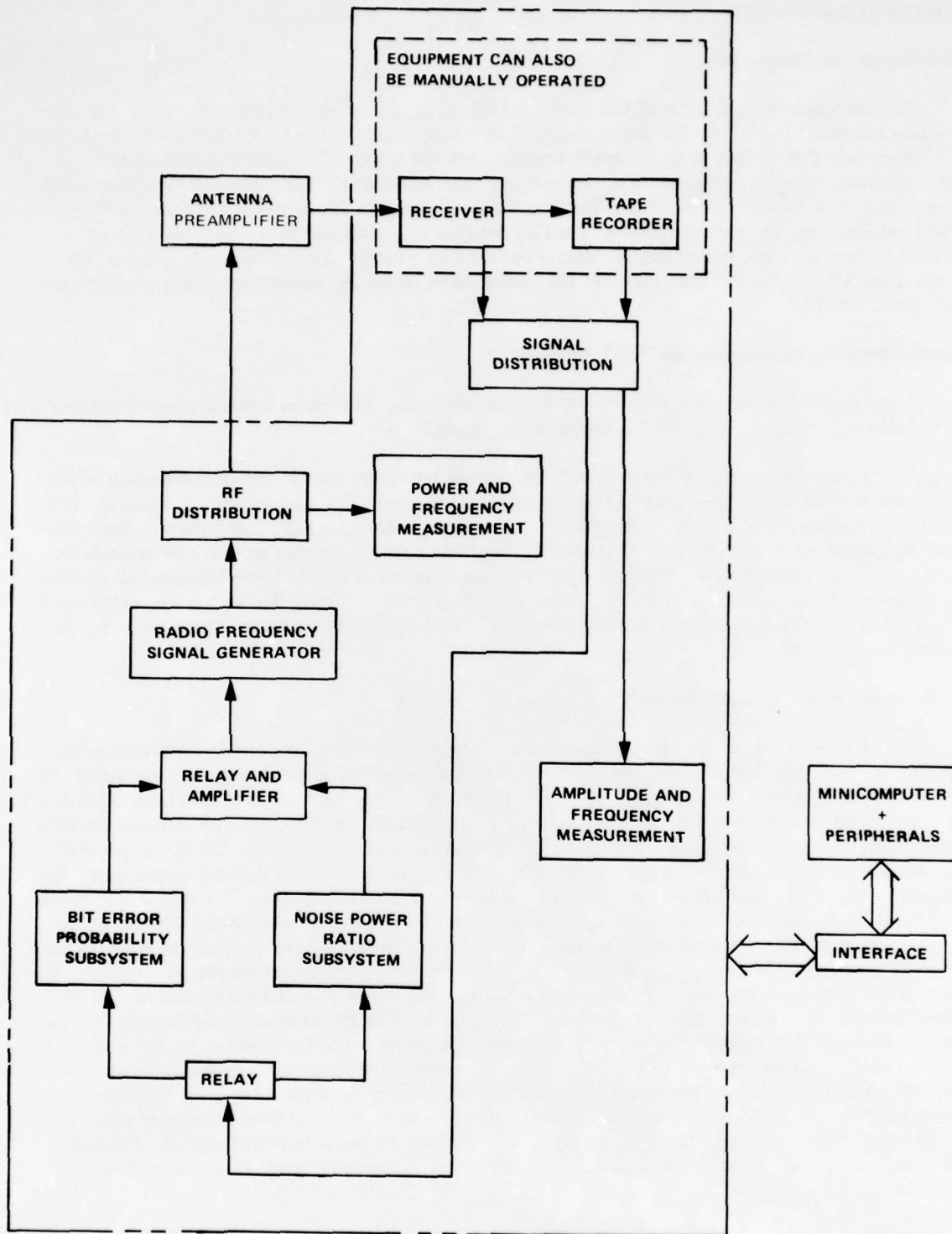

Figure 1. SCATS Block Diagram.

EQUIPMENT DESCRIPTION

Minicomputer and Peripherals

The minicomputer used in the SCATS system is a Digital Equipment Corporation PDP-11/34. The main peripherals include: two RL-01 disk drives, an RX-01 dual floppy disk drive, an LA36 teletypewriter, a VT52 cathode ray tube (CRT) terminal, an IEEE-488 interface card, and a DR-11C instrument interface card. The operating system currently being used is RT-11 version 3. The RL-01 disk drives contain the operating system, library routines, and the SCATS software. The floppy disks are used for the storage of test data. Both soft (CRT) and hard copy displays are available. The CRT terminal is portable and several interface plugs are available in the operational ground station. This allows the CRT terminal to be moved to the antenna console to run antenna figure of merit tests, etc. The test results can be stored and a hard copy output produced at a later time if desired.

Interface Between Minicomputer and Test Equipment

Communication between the minicomputer and the test equipment is via an in-house designed and fabricated "Port Expander" interface. This interface is described in appendix A.

One of the major expense and time items in SCATS was the design, construction, and debugging of the special interfaces for the various pieces of equipment. Most of the SCATS equipment was purchased in 1975 and the interfaces are mostly unique. Since that time, the IEEE-48 Interface has gained wide acceptance, and much equipment is now available with this interface. IEEE-488 Interface adaptors are also now available for many instruments which are not available with this interface. The use of the IEEE-488 Interface will minimize the hardware interface development but may transfer the effort to the software. The software problems can be minimized by selecting a controller which is optimized for use the IEEE-488 Interface. The in-house interfaces have worked very well.

RF Signal Generator, Telemetry Receiver, and Associated Equipment

The RF signal generator is a Microdyne Corporation Model 7100 SL(P). The output frequencies of this generator are 1435-1540 and 2200-2300 MHz. The generator can be either phase or frequency modulated. The peak deviations are $\pm 600^\circ$ and ± 6 MHz. The modulation frequency response is within ± 1 dB from DC to 3 MHz for phase modulation and from DC to 4 MHz for frequency modulation. This is more than sufficient for PCM bit rates up to 3 megabits per second (Mb/s) (current maximum capability of SCATS). The RF output level is controllable in 1 dB steps from -129 dBm to +10 dBm. The RF frequency can be remotely controlled by the selection of one of 20 crystals or by the insertion of an external reference frequency. The normal SCATS mode of operation is to insert a reference frequency from the Fluke 8160B frequency synthesizer. This allows the programming of the RF output frequency to within 100 Hz of any desired frequency within the operating range of the RF generator. The RF output power is measured using a Boonton 42BD autoranging power meter. This power meter has an accuracy of ± 0.3 dB for power levels from -50 to +10 dBm and a resolution of 0.01 dB. The RF generator output is connected to the RF distribution unit. The RF distribution unit contains isolated power dividers and RF switches. The RF signal is continuously connected to the power meter, RF counter, and spectrum analyzer for monitoring, and the RF signal is also connected to either an S- to P-band down converter or to the antenna patch panel. The P-band signal is sent to the receiver patch panel for direct insertion into the operational telemetry receivers (this telemetry ground station converts the L- and S-band telemetry signals to P-band in the antenna pedestals, therefore, the operational receivers operate with P-band signals). The normal test mode is to split the L- or S-band signal into two equal parts and apply these signals to the antenna preamplifiers.

The telemetry receiver is a Microdyne 2200R(N) dual-channel receiver with a 2212-VT(N) synthesized RF tuner. The synthesized tuner operates over the frequency range of 215 to 320 MHz. The frequency is remotely

programmable with a step size of 100 kHz. The receiver has six remotely selectable second IF bandwidths: 100, 300, 500, 1000, 1500, and 3300 kHz. The demodulator bandwidth is slaved to the IF bandwidth. Twelve video bandwidths are available for remote selection. The automatic gain control (AGC) voltage can be remotely "frozen" at any time. This allows measurement of signal plus noise and noise with the same gain. This is vital to the antenna figure of merit and IF SNR tests. The receiver is connected to a diversity combiner which contains remotely controllable predetection down converters (the predetection output frequency is selectable) as well as a predetection or postdetection combiner (switch selectable).

The most critical features of the equipment in the RF section of SCATS are the frequency and output power stability of the RF generator, the frequency stability of the frequency synthesizer, the accuracy of the RF power meter, the frequency and gain stability of the telemetry receiver, and the linearity and bandwidth of the frequency and phase modulators and demodulators.

BEP and NPR Test Equipment

The current SCATS PCM test set is an International Data Sciences Model 1000. This test set generates/receives the standard IRIG 2047-bit pseudo-noise sequence. However, this PCM test set only generates the non-return-to-zero-level (NRZ-L) code and has a maximum bit rate of 1 Mb/s. It will be replaced by a Decom Systems Incorporated Model 7193 PCM test set. The model 7193 generates all of the standard IRIG codes, uses either an internal or external clock, and handles bit rates up to 5 Mb/s. A Wavetek Model 159 function generator is used to provide the transmitter clock. The PCM test set also detects errors in the received pseudo-noise pattern. The ratio of bits in error to bits transmitted is measured using a Dana Model 8010B counter.

A programmable gain amplifier is used to control the RF deviation during the BEP tests. The programmable gain amplifier has a bandwidth (-3 dB) of DC to 2.0 MHz. The gain can be varied from 0.006 to 1.0 (gain = 0.995^X where $0 \leq X \leq 1023$). The PCM input to the programmable gain amplifier goes through two 2-input NAND gates. The PCM data can be set to the high level ("1"), reset to the low level ("0"), or passed through unaltered. This feature is used in setting the frequency deviation in the BEP and NPR tests. An Electro-Mechanical Research Model 720-02 PCM bit synchronizer is used to synchronize and reconstruct the input PCM data. This bit synchronizer accepts all the standard IRIG codes, bit rates from 1 bit per second to 5 Mb/s, and provides selectable output polarity and reconstructed NRZ-L and clock outputs.

The white noise generator is a Marconi Instruments Model 2091C. The output power is variable from -59.9 to +19.9 dBm in 0.1 dB steps. The noise bandwidth can be varied by the insertion of various high- and low-pass filters. The current capabilities are 12 to 108 kHz and 12 to 252 kHz. The band-stop frequencies can be varied by the insertion of various filters. The current band-stop frequencies are: 16, 40, 70, 98, 140, and 185 kHz. The output noise level is automatically level controlled, that is, when a band-stop filter is selected the noise power at all other frequencies is increased by the amount required to keep the total output power at the selected level. The noise output can also be turned completely off.

The noise receiver is a Marconi Instruments Model 2090C. The noise receiver has band-pass filters matched to the noise generator band-stop filters. The noise powers with the band-stop filter "out" and "in" are measured with a resolution of 0.5 dB. The difference in the two values is the NPR.

The predetection discriminators are pulse-averaging discriminators. Every zero crossing is detected and a constant width and amplitude pulse is generated. This produces a pulse train at twice the input frequency. This pulse train is then low-pass filtered (the low-pass filter bandwidth is approximately one-half the discriminator center frequency). The output voltage is directly proportional to the number of pulses which is directly proportional to the input frequency. This demodulation technique was selected because of its excellent linearity. The main limitation is in maximum data rate. PCM data (NRZ-L) at bit rates above 65 percent of the center frequency are degraded by the interference between the data and the sidebands of the pulse train. Signals with higher bit rates should be demodulated before being applied to SCATS (the demodulation should be done at 10 MHz for best performance).

Other Equipment

The amplitude of all signals between 10 Hz and 20 MHz is measured using an autoranging Boonton 93 AD true RMS voltmeter. This meter has a resolution of 0.01 dB and an accuracy of approximately ± 0.2 dB. All amplitudes are read in dBm. A second Boonton 93 AD is available for exchange when the first must be calibrated or repaired.

The frequency of all signals below 150 MHz is measured using a Dana 8010B counter. This counter has remote control of all functions including trigger level. The time base is variable from 1 microsecond to 100 seconds. The frequency ratio mode has a range of 10^0 to 10^9 . This allows bit error probability measurements to be made over any number of bits (in powers of 10) up to 10^9 bits. The usual interval is 10^6 bits.

A Wavetek 159 function generator is used to provide the clock for the PCM generator; the various frequency sine waves to measure tape recorder frequency response, etc. The frequency, amplitude, and offset, are selectable to three digits and sine, triangle, and square waves can be generated.

SCATS uses eight discrete relays to interconnect instruments. The relays have either five or eight throws, greater than 60 dB of isolation at 10 MHz, and a DC to 300 MHz bandwidth. SCATS also contains two 10 x 10 relay matrices which are used to interconnect instruments and also to connect SCATS to the operational ground station equipment. The matrices have a bandwidth of DC to 20 MHz.

The controller for the programmable gain amplifier, the relays, and the matrices allows for either manual or computer control. The programmable gain amplifier is manually controlled by a series of two-position switches. The relays are manually controlled by two 10-position thumbwheel switches as are the matrices. The last setting (could be manual or computer) of any relay is held until the relay is set to a different position.

SCATS SOFTWARE

The SCATS software provides for operator selection of tests to be run; execution of the tests; monitoring of equipment during the test; analysis, display, and storage of test results. The software provides extensive guidance indicating the options available, responses required at each step, and informing the operator of any manual steps that must be performed. The operator has full control in selecting the sequence in which tests are run, the parameters to be used in conducting the test, and whether the results are to be saved.

The software for the SCATS has been written primarily in FORTRAN with only a few assembly language subroutines used as drivers to interface with nonstandard external equipment. Four major programs provide all of the testing and data retrieval capabilities. An additional group of small programs provides supporting functions such as maintenance of equipment characteristic files, initialization of archive files, self-test capabilities, etc.

Due to their size, some programs have been overlaid in order to fit within the available memory. However, overlaying aided the program development inasmuch as each overlay represented a more or less independent block of code which could be worked with individually.

Four files constitute the SCATS data base. Two of these files contain information used by the system in executing test sequences, and the remaining two are used to archive test results. One input file contains cable loss values and noise figures associated with various equipment to which the SCATS can be connected. The second file is used to input test parameters such as IF bandwidth, peak deviation, center frequency, etc. Up to ten test parameter setups can be generated and saved by name in this file. This feature permits convenient operator specification of repeatedly used sets of test parameters.

One of the output files generated is used to archive the results of the BEP, NPR, IF SNR, and solar calibration tests. The second output file is unique to solar calibrations and contains for each antenna and

frequency band the statistical data summarizing past performance. A data retrieval program is available which permits review of the file contents, printout of specific data, and the summarization of data. The capability has been provided to permit data retrieval by specifying desired combinations of equipment number, date period, and many of the test parameters.

TEST PARAMETER ENTRY

The test operator can create a data file which contains the following data:

1. RF center frequency
2. IF bandwidth (SCATS receiver)
3. Video bandwidth (SCATS receiver)
4. Predetection carrier frequency
5. Counter time base exponent (BEP test measurement interval in bits)
6. PCM bit rate
7. Peak RF frequency deviation (for BEP test)
8. rms RF frequency deviation (for NPR test)

This data file can then be called any time the operator wants to run a test with these parameter values. Any data entry in the file can be changed individually. A sample SCATS log-in and IF bandwidth change is shown in figure 2. The data entered by the test operator is underlined.

ANTENNA FIGURE OF MERIT TEST

This test determines the antenna figure of merit which is ten times the logarithm of the ratio of the antenna gain to the system noise temperature (G/T). The G/T is measured at ten frequencies at S-band and three frequencies at both upper and lower L-band and for both antenna polarizations. The SCATS equipment used in this test are: telemetry receiver, rms meter, RF distribution unit, and discrete relays (see figure 3). The antenna outputs are manually patched into the SCATS receiver and the solar flux, flux measurement frequency, Julian date, and Greenwich Mean Time are entered into the computer terminal. The sun position is calculated and printed out. The antenna is then manually pointed at the sun and put into autotrack mode. A data entry example is shown in figure 4.

The program first determines if the largest signal is received at the low or high end of the passband with the antenna tracking the sun. The gain is set (for each receiver channel independently) at the frequency with the largest signal. The rms value of the receiver linear 10 MHz is then measured at each frequency for both receiver channels. A check is made to verify that the receiver gain (or something else) has not changed by remeasuring the signal at the lowest frequency and comparing it to the value measured earlier. The antenna is then pointed at the cold sky (30° in *elevation* from the sun) and the rms values are again measured. The figure of merit is calculated from the following equation (see reference 1).

$$10 \log G/T = 10 \log \frac{8\pi K L \left(\frac{P_2}{P_1} - 1 \right)}{F_o \left(\frac{f}{f_o} \right)^2 \lambda^2} \quad (1)$$

¹Range Commanders Council IRIG Document, 118-73, Revised July 1975, "Test Methods for Telemetry Systems and Subsystems," Secretariat, White Sands Missile Range.

• R SCATS

SELF CHECK AUTOMATED TELEMETRY SYSTEM (SCATS)

YEAR 79

JULIAN DAY 147

HOUR 23

MINUTE 20

TYPE:

1 = LIST DATA SET NAMES
2 = READ DATA SET NAME FILE
3 = WRITE DATA SET FILE
4 = INPUT OR EDIT DATA SET
5 = RETURN TO SCATS MONITOR 2

TYPE DATA SET NAME: LAW

DATA SET: LAW

CENTER FREQ = 2250.5 IF BW =1500 VIDEO BW =1000
PRE-D = 450 TIMEBASE EXP = 6 BIT RATE = 240000.
RF PEAK DEV(BEP) = 84000. RF RMS DEV(NPR) = 100000.

TYPE:

1 = LIST DATA SET NAMES
2 = READ DATA SET NAME FILE
3 = WRITE DATA SET FILE
4 = INPUT OR EDIT DATA SET
5 = RETURN TO SCATS MONITOR 4

INPUT DATA, TYPE:

1 = CENTER FREQ
2 = IF BW
3 = VIDEO BW
4 = PRE-D FREQ
5 = COUNTER TIME BASE EXP
6 = BIT RATE
7 = RF DEVIATION(BEP)
8 = RF DEVIATION(NPR)
9 = TERMINATE INPUT

NUMBER: 2

RECEIVER IF BANDWIDTH(KHZ): 500

NUMBER: 9

TYPE:

1 = LIST DATA SET NAMES
2 = READ DATA SET NAME FILE
3 = WRITE DATA SET FILE
4 = INPUT OR EDIT DATA SET
5 = RETURN TO SCATS MONITOR 5

Figure 2. SCATS Log-In and Parameter Entry.



COLD
SKY

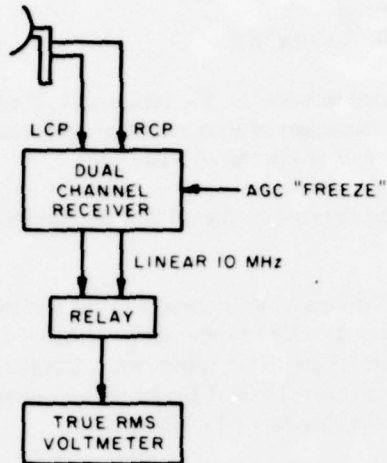

Figure 3. Antenna Figure of Merit (G/T) Configuration.

J. R. SUNCAL

SOLAR CALIBRATION TEST

ENTER FREQUENCY BAND:

1=LOWER L-BAND
2=UPPER L-BAND
3=S-BAND 3

ENTER ANTENNA NUMBER: 1

CHECK THAT RECEIVER CHANNEL 1 IS PATCHED TO RHC.
CHECK THAT RECEIVER CHANNEL 2 IS PATCHED TO LHC.
MOUNT SUN.DAT FLOPPY IN DX1.
TYPE CARRIAGE RETURN.

ENTER SOLAR FLUX (REAL): 152

ENTER SUN MEASUREMENT FREQUENCY IN MHZ (REAL): 2800

YEAR 79

ENTER JULIAN DAY: 145

ENTER GMT HOUR: 22

ENTER MINUTE: 37

261.25 AZIMUTH OF SUN IN DEGREES.
51.66 ELEVATION OF SUN IN DEGREES.

OBTAIN SUN AUTOTRACK.
TYPE CARRIAGE RETURN.

POINT ANTENNA AT COLD SKY.
TYPE CARRIAGE RETURN.

Figure 4. Antenna Figure of Merit (Solar Calibration) Data Entry.

where L = antenna beam-width correction factor = $1 + 0.38 \left(\frac{0.5^\circ}{\text{Antenna beam-width}} \right)^2$

- P_2 = Sun power
- P_1 = Cold sky power
- F_0 = Solar flux (watts/m²/Hz)
- f_0 = Solar flux measurement frequency
- f = Test frequency
- λ = Test frequency wavelength (meters)
- K = Boltzmann's constant = $1.38 \cdot 10^{-23}$ watts/°K/Hz

A typical figure of merit test output is presented in table 1. The measured G/T values as well as the prior cumulative averages, maximums, minimums, percentages of time exceeding specification, and standard deviations are displayed. The test operator has three options at the end of a G/T test:

1. He can archive the data. This means that the data is entered into the statistical file for that antenna and is also saved for later recall.
2. He can save the data. This means that the data is not entered into the statistical file at this time but the data is saved for later recall. The data can be added to the statistical file at a later time. The saved data can also be modified by correcting inaccurate solar flux entries, etc. This is especially useful if a current solar flux value is not available at the test time. The test can be performed with an estimated solar flux, the data can be saved, and the correct solar flux entered when available.
3. The test operator also has the option of not storing the data in any data file. This is useful if the results are not valid because of interfering frequencies, patching errors, etc.

The main sources of error are: The latest solar flux value may have been measured several hours ago and the solar flux may have changed since then, the extrapolation from the flux measurement frequency to the antenna measurement frequency is not exact, the rms meter has a specified accuracy of ± 0.2 dB, the antenna system and receiver introduce errors because of gain changes during the test and amplitude nonlinearities, and there may have been unnoticed interfering signals present. However, the SCATS system gives G/T results which are quite repeatable (within ± 0.3 dB at S-band for tests which are run within a few minutes of each other) and agree very well with measurements made manually using the calibrated attenuator method. The overall accuracy is estimated to be better than ± 1.0 dB at S-band.

The difference between the maximum and minimum measured S-band G/T values (at each frequency) varies from 1.5 to 2.4 dB for antenna 1 and from 1.2 to 1.8 dB for antenna 4 (see tables 2 and 3). The standard deviations are approximately 0.5 dB for antenna 2 and 0.35 dB for antenna 4. Seventy percent of the LCP G/T values and 84 percent of the RCP G/T values are within ± 0.5 dB of the average for antenna 1 at 2250.5 MHz. The lower L-band G/T standard deviations for antenna 4 are about 0.35 dB (see table 4). The upper L-band G/T standard deviations for antenna 4 are about 0.5 dB (see table 5). The statistical data presented in tables 2, 3, 4, and 5 represent data taken between May 1978 and February 1979. The statistical data in table 1 represent data taken between March 1979 and May 1979.

Since the G/T values are stored on a floppy diskette, various analyses can be performed on the data by writing the necessary software. One existing program prints out the overall statistical data along with the results of all G/T tests that meet the conditions specified:

- | | |
|----------------------------------|------------------------------------|
| 1. Antenna number | 5. Low solar flux |
| 2. Frequency band | 6. High solar flux |
| 3. Start year, day, hour, minute | 7. Low flux measurement frequency |
| 4. End year, day, hour, minute | 8. High flux measurement frequency |

Table 1. Antenna Solar Calibration Test Output

ANTENNA SOLAR CALIBRATION
 YEAR=79 JULIAN DAY=145 GMT HOUR=22 MINUTE=37
 SOLAR FLUX= 152.0 AT 2800.0 MHZ
 ANTENNA# = 1 RHC

NUMBER OF TESTS 5

FREQ (MHZ)	RMS-MEIER (DB)		THIS TEST	G/I (DB)			Z GE	
	SUN	COLD SKY		AVE	MAX	MIN	15 DB	S.D.
2200.5	-16.6	-32.7	17.9	18.0	18.2	17.8	100.00	0.14
2210.5	-14.3	-30.4	17.9	18.0	18.3	17.8	100.00	0.14
2220.5	-13.9	-30.1	18.0	18.1	18.3	17.9	100.00	0.15
2230.5	-13.5	-29.6	18.0	18.0	18.3	17.8	100.00	0.14
2240.5	-14.0	-30.2	18.1	18.2	18.4	18.1	100.00	0.12
2250.5	-14.4	-30.5	18.0	18.1	18.3	17.9	100.00	0.13
2260.5	-16.1	-31.8	17.7	17.8	18.1	17.5	100.00	0.17
2270.5	-17.4	-32.9	17.5	17.6	17.9	17.3	100.00	0.20
2280.5	-18.4	-34.4	18.0	18.0	18.4	17.8	100.00	0.21
2290.5	-18.3	-34.3	18.1	18.1	18.3	17.9	100.00	0.15

ANTENNA# = 1 LHC

FREQ (MHZ)	RMS-MEIER (DB)		THIS TEST	G/I (DB)			Z GE	
	SUN	COLD SKY		AVE	MAX	MIN	15 DB	S.D.
2200.5	-15.5	-31.5	17.8	17.8	18.0	17.6	100.00	0.15
2210.5	-14.8	-30.8	17.9	18.0	18.2	17.9	100.00	0.12
2220.5	-13.1	-29.0	17.8	18.0	18.1	17.8	100.00	0.10
2230.5	-13.4	-29.2	17.6	17.8	18.0	17.6	100.00	0.11
2240.5	-14.5	-30.3	17.7	17.7	17.8	17.6	100.00	0.08
2250.5	-14.3	-30.0	17.6	17.6	17.8	17.5	100.00	0.08
2260.5	-14.3	-29.9	17.6	17.6	17.8	17.5	100.00	0.10
2270.5	-16.5	-32.2	17.7	17.7	18.0	17.5	100.00	0.20
2280.5	-17.1	-32.8	17.8	17.7	18.1	17.5	100.00	0.23
2290.5	-18.3	-33.9	17.6	17.6	17.9	17.4	100.00	0.22

COMMENTS:

Table 2. Antenna Solar Calibration, S-Band, Antenna 1

ANTENNA SOLAR CALIBRATION
 YEAR=78 JULIAN DAY=151 GMT HOUR=22 MINUTE=50
 SOLAR FLUX= 148.0 AT 2800.0 MHZ
 ANTENNA# = 1 RHC

NUMBER OF TESTS 38

FREQ (MHZ)	THIS TEST	G/I (DB)			Z GE	
		AVE	MAX	MIN	15 DB	S.D.
2200.5	18.5	18.0	18.9	17.2	100.0	0.38
2210.5	18.7	18.1	19.1	17.2	100.0	0.42
2220.5	18.8	18.2	19.2	17.4	100.0	0.47
2230.5	18.6	18.0	19.0	17.3	100.0	0.48
2240.5	18.5	18.0	19.1	17.4	100.0	0.41
2250.5	18.4	18.0	19.0	17.2	100.0	0.41
2260.5	18.3	17.8	18.8	17.2	100.0	0.41
2270.5	18.3	17.8	18.6	17.1	100.0	0.46
2280.5	18.5	18.0	18.9	17.3	100.0	0.41
2290.5	18.3	18.0	18.9	17.4	100.0	0.38

ANTENNA# = 1 LHC

FREQ (MHZ)	THIS TEST	G/I (DB)			Z GE	
		AVE	MAX	MIN	15 DB	S.D.
2200.5	18.3	18.0	19.1	17.2	100.0	0.48
2210.5	18.6	18.1	19.3	17.3	100.0	0.49
2220.5	18.2	18.0	19.4	17.2	100.0	0.50
2230.5	17.7	17.8	19.1	17.2	100.0	0.50
2240.5	18.3	17.9	19.0	17.0	100.0	0.54
2250.5	18.4	17.8	19.0	17.0	100.0	0.52
2260.5	18.0	17.7	19.0	17.0	100.0	0.51
2270.5	17.8	17.8	19.2	17.0	100.0	0.53
2280.5	18.0	17.9	19.4	17.0	100.0	0.54
2290.5	18.4	17.8	19.1	16.9	100.0	0.56

Table 3. Antenna Solar Calibration, S-Band, Antenna 4

ANTENNA SOLAR CALIBRATION
 YEAR=78 JULIAN DAY=151 GMT HOUR=22 MINUTE=43
 SOLAR FLUX= 148.0 AT 2800.0 MHZ
 ANTENNA# = 4 RHC

FREQ (MHZ)	IBIS TEST	G/T (DB)			Z GE	
		AVE	MAX	MIN	15 DB	S.D.
2200.5	17.9	17.5	18.2	16.8	100.0	0.37
2210.5	18.3	17.8	18.5	17.0	100.0	0.41
2220.5	18.3	17.9	18.5	17.0	100.0	0.36
2230.5	18.1	17.7	18.3	17.1	100.0	0.33
2240.5	18.0	17.8	18.4	17.0	100.0	0.32
2250.5	18.1	17.8	18.3	17.0	100.0	0.35
2260.5	18.0	17.6	18.3	16.8	100.0	0.37
2270.5	17.7	17.4	18.1	16.7	100.0	0.33
2280.5	17.8	17.5	18.2	16.9	100.0	0.31
2290.5	17.6	17.4	18.2	16.7	100.0	0.34

ANTENNA# = 4 LHC

FREQ (MHZ)	IBIS TEST	G/T (DB)			Z GE	
		AVE	MAX	MIN	15 DB	S.D.
2200.5	17.8	17.4	18.4	16.6	100.0	0.44
2210.5	17.9	17.8	18.6	17.0	100.0	0.32
2220.5	18.1	17.9	18.6	17.2	100.0	0.29
2230.5	18.0	17.7	18.3	17.1	100.0	0.31
2240.5	18.1	17.8	18.4	17.1	100.0	0.32
2250.5	18.1	17.8	18.4	17.0	100.0	0.32
2260.5	17.8	17.7	18.4	16.8	100.0	0.36
2270.5	17.8	17.5	18.2	16.5	100.0	0.36
2280.5	17.8	17.5	18.2	16.7	100.0	0.34
2290.5	17.6	17.4	18.1	16.3	100.0	0.36

Table 4. Antenna Solar Calibration, Lower L-Band, Antenna 4

ANTENNA SOLAR CALIBRATION
 YEAR=78 JULIAN DAY=152 GMT HOUR=22 MINUTE=37
 SOLAR FLUX= 145.0 AT 2800.0 MHZ
 ANTENNA# = 4 RHC

FREQ (MHZ)	IBIS TEST	G/T (DB)			Z GE	
		AVE	MAX	MIN	11 DB	S.D.
1435.5	14.2	13.9	14.6	13.1	100.0	0.33
1485.5	14.1	13.8	14.5	13.1	100.0	0.38
1535.5	13.8	13.8	14.1	13.4	100.0	0.19

ANTENNA# = 4 LHC

FREQ (MHZ)	IBIS TEST	G/T (DB)			Z GE	
		AVE	MAX	MIN	11 DB	S.D.
1435.5	14.2	13.6	14.5	12.7	100.0	0.62
1485.5	13.9	13.8	14.3	12.5	100.0	0.32
1535.5	14.0	13.7	14.2	13.1	100.0	0.31

Tables 2, 3, 4, and 5 were generated using this program. Another program prints out all G/T values for specified frequencies which meet the conditions specified above. This program also calculates the averages and standard deviations of the printed G/T values. Table 6 lists all G/T values for 2250.5 MHz on antenna 4 with a solar flux between 120 and 170 and a flux measurement frequency of 2800 MHz. Table 7 shows the average G/T values and the standard deviations for antennas 1 and 4 at 2250.5 MHz separated by solar flux value. Usually the sun is less stable as the solar flux increases, therefore the standard deviations should be larger for increasing solar flux. However, the standard deviations in table 7 decrease for increasing solar flux. The G/T values also decrease for increasing solar flux; however, the decrease is small (0.2 dB for three of the four cases).

SCATS performs an S-band G/T test in about seven minutes (this includes the time it takes to enter data and manually point the antenna). It would take at least 30 minutes to manually measure the sun and cold sky powers and calculate the 20 G/T values. Any manual statistical data analysis would be extremely time consuming.

Table 5. Antenna Solar Calibration, Upper L-Band, Antenna 4

ANTENNA SOLAR CALIBRATION
 YEAR=78 JULIAN DAY=153 GMT HOUR=21 MINUTE=27 NUMBER OF TESTS 15
 SOLAR FLUX= 145.0 AT 2800.0 MHZ
 ANTENNA# = 4 RHC

FREQ (MHZ)	THIS TEST	G/T (DB)			Z. AGE	
		AVE	MAX	MIN	13 DB	S.D.
1750.5	16.2	16.0	16.7	15.5	100.0	0.36
1800.5	16.5	16.3	17.0	15.9	100.0	0.54
1850.5	16.9	16.6	17.6	16.0	100.0	0.55

ANTENNA# = 4 LHC

FREQ (MHZ)	THIS TEST	G/T (DB)			Z. AGE	
		AVE	MAX	MIN	13 DB	S.D.
1750.5	16.2	15.9	16.9	15.3	100.0	0.48
1800.5	16.4	16.3	17.1	15.6	100.0	0.43
1850.5	17.1	16.6	17.5	15.6	100.0	0.58

Table 6. Solar Calibration Data Summary, S-Band, Antenna 4

INPUT COMMAND LINE
 S-1-4-----3-120-170-2800-2800-2250.5-----
 SOLAR CALIBRATION DATA SUMMARY

ANTENNA 4		MEASUREMENT FREQUENCY 2250.5				
YEAR	JULIAN DAY	HOUR	FLUX FREQ.	•FLUX	LH	RH
78	129	16	2800.0	141.0	17.2	17.1
78	129	19	2800.0	141.0	17.6	17.6
78	130	22	2800.0	127.0	17.9	17.9
78	132	20	2800.0	131.0	17.6	17.7
78	132	19	2800.0	135.0	17.9	17.5
78	133	17	2800.0	135.0	18.1	18.0
78	133	20	2800.0	137.0	18.1	18.2
78	133	22	2800.0	137.0	18.1	18.1
78	135	18	2800.0	143.0	18.0	17.9
78	136	18	2800.0	149.0	17.7	17.8
78	138	16	2800.0	150.0	17.0	17.4
78	142	18	2800.0	135.0	18.1	17.7
78	144	23	2800.0	145.0	17.9	17.9
78	151	22	2800.0	148.0	18.1	18.1
78	152	22	2800.0	145.0	18.0	18.1
78	179	22	2800.0	168.0	17.7	17.7
78	181	21	2800.0	149.0	17.4	17.2
78	201	23	2800.0	141.0	17.8	17.5
78	338	23	2800.0	169.0	17.7	17.9
78	354	22	2800.0	143.0	17.6	18.0

IF MORE DATA MOUNT NEXT FLOPPY AND TYPE Y
 OTHERWISE TYPE N
 N

NUMBER OF RUNS=	20	AVERAGE	17.8	17.8
		STANDARD DEVIATION	0.29	0.30

Table 7. Solar Calibration Means and Standard Deviations, 2250.5 MHz
(All Averages (AVE) and Standard Deviations (SD) Are in Decibels)

Solar Flux Range (2800 MHz)	No. of Tests	ANT 1				No. of Tests	ANT 4			
		LCP		RCP			LCP		RCP	
		AVE	SD	AVE	SD		AVE	SD	AVE	SD
102-119	13	18.0	0.54	18.1	0.42	8	17.9	0.34	17.9	0.35
120-170	14	17.9	0.48	17.9	0.41	20	17.8	0.29	17.8	0.30
171-207	6	17.4	0.26	17.9	0.25	6	17.7	0.11	17.7	0.27

INTERMEDIATE FREQUENCY SNR TEST

This test determines the RF powers which give SNRs in the receiver second IF of 0 and 10 dB. This data is then used to calculate the effective system noise temperature from the equation:

$$N = KTB \text{ or } T = \frac{N}{KB} \quad (2)$$

where

- N = noise power = signal power at 0 dB IF SNR
- K = Boltzmann's constant
- T = Effective system noise temperature (°K)
- B = IF bandwidth in hertz

The system noise figure is then calculated from

$$F = 1 + \frac{T}{290^{\circ}} \quad (3)$$

This test uses the RF signal generator, RF power meter, counter, telemetry receiver, rms meter, RF distribution unit, and the discrete relays (see figure 5). The IF SNR test can be performed at lower L-band and at S-band.

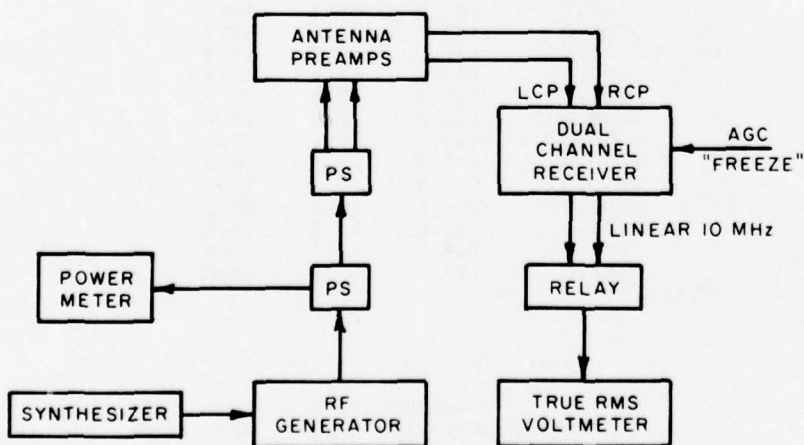

Figure 5. Receiving System Sensitivity Test (IF SNR) Configuration.

The test procedure is to insert a known RF power into the antenna preamplifier, measure the IF SNR, and then extrapolate to the 0 and 10 dB IF SNR power levels. The RF generator is then set to the expected power level and the IF SNR is measured. If it is within 1.0 dB of the desired IF SNR, the RF power for the desired SNR is calculated by subtracting the SNR error from the measured RF power.

If the measured value is not within 1.0 dB of the desired value, a new estimate of RF power for the desired SNR is made, the RF generator output power is changed, and the measurement repeated. The measurement procedure is:

1. Point antenna at cold sky (away from sun and other signal sources).
2. Set RF generator to desired power.
3. Measure power with RF power meter.
4. "Freeze" gain of receiver.
5. Measure rms voltage in receiver linear 10 MHz output of both receiver channels (S + N).
6. Set RF generator output to minimum power.
7. Measure rms voltage in receiver linear 10 MHz output of both receiver channels (N).
8. Calculate IF SNR from: $IF\ SNR = \frac{(S + N)^2 - N^2}{N^2}$.
9. Display: $10 \log (IF\ SNR)$.

The sources of error are the same as for the antenna figure of merit test except that the errors due to solar flux inaccuracies are replaced by errors due to inaccuracies in cable loss, connector loss, power meter errors, etc. The IF SNR accuracy is about ± 0.5 dB.

A typical IF SNR test output is shown in table 8. The output includes the time, RF frequency, IF bandwidth, and antenna number. The RF power which gives a 0 and a 10 dB SNR for each receiver channel is displayed along with the calculated noise figure, noise temperature, and estimated G/T. The short-term IF SNR repeatability is shown in table 9. Four tests were performed in a span of about 12 minutes. The results with a -10 dBm RF generator output are displayed. The data spread is ± 0.01 dB. This experiment has been repeated several times with similar results. A comparison between the results of an IF SNR test and a G/T test performed within a few minutes of each other is shown in table 10. The estimated G/T agrees with the measured G/T

Table 8. SCATS IF SNR Test Output

```

YEAR=79 JULIAN DAY=159 HOUR=22 MINUTE=49
FREQ(MHZ)=2250.5 IFBW(KHZ)=1500 VIDEO BW(KHZ)=1000
ANTENNA NUMBER 3

```

CHANNEL 1						EST. G/T(DB)
IFSNR(DB)	RF GEN(DB)	RF POWER(DBM)	NOISE FIGURE(DB)	NOISE TEMP(K)		(G=42.5 DB)
0	-38.0	-111.7	3.3	324.		17.4
10	-27.0	-101.5	3.4	343.		17.1
CHANNEL 2						EST. G/T(DB)
IFSNR(DB)	RF GEN(DB)	RF POWER(DBM)	NOISE FIGURE(DB)	NOISE TEMP(K)		(G=42.5 DB)
0	-38.0	-111.9	3.2	310.		17.6
10	-28.0	-101.7	3.3	324.		17.4

COMMENTS:

Table 9. IF SNR Repeatability (Antenna 1, 1.5 MHz IF BW)

Run	RF Power (dBm)	LCP SNR (dB)	RCP SNR (dB)
1	-85.75	26.85	26.48
2	-85.75	26.86	26.49
3	-85.75	26.86	26.50
4	-85.75	26.86	26.50

Table 10. Comparison Between Results of IF SNR Test and G/T Test

IF SNR (dB)	RF Power (dBm)	System Noise Temp. ($^{\circ}$ K)	G = 42.5 dB EST. (G/T) (dB)	G/T Test (dB)	
				11/6/78	Ave.
0	-112.3	285	17.95	17.8	18.0
10	-102.3	286	17.94		

ANTENNA 1 RCP 11/6/78
 2250.5 MHz 1.5 MHz IF BW (IF SNR TEST)

within 0.15 dB. The average agreement of the two tests is better than ± 0.5 dB. Since the G/T test uses the entire receiving system and the IF SNR test only uses the part of the receiving system starting with the preamplifier, the two tests can be used together to isolate a failure in either the hardware in front of the preamplifier or the equipment starting with the preamplifier. The IF SNR test results can also be used to calibrate the AGC voltages of the receivers. The operator can set the IF SNR to 42 dB, to noise (no RF signal), or can start a calibration in 6-dB steps.

PULSE CODE MODULATION BIT ERROR PROBABILITY TEST

This test determines the bit error probability (BEP) versus RF power performance of the equipment under test. The BEP test can currently be performed only for nonreturn-to-zero-level (NRZ-L) FM formats but will be expanded to include at least Manchester and PM formats. The BEP test can be performed by inserting an RF signal into either an antenna preamplifier or directly into a telemetry receiver. The antenna system output (if an antenna is used) is patched to the receiver(s) to be tested and the antenna is pointed at the cold sky. The receiver output is either connected to one of the SCATS data inputs or to a tape recorder (or both). If a tape recorder is used, its output is patched to one of the SCATS data inputs. SCATS accepts 450- and 900-kHz FM predetection and video signals at its data inputs. The predetection signals are first demodulated using a pulse-averaging discriminator and then applied to the PCM bit synchronizer. The video signals are applied directly to the bit synchronizer. The reconstructed data and clock from the bit synchronizer are connected to the PCM test set for error detection. The counter displays the ratio of bit errors to bits received (bit error probability). A block diagram of the equipment interconnections for this test is shown in figure 6. The test sequence is:

1. The test operator first loads the proper SCATS data file. The RF frequency, PCM bit rate, peak RF deviation, and counter time base exponent are set using the data from this file. The operator then enters the number of the antenna being used (if one is used), the data type, the receiver IF bandwidth, the receiver number

and channel, the tape recorder number and track (if a recorder is used), and the RF power step size (1, 2, 3, 4, etc., dB). A sample data entry is shown in figure 7. The data entered by the test operator is underlined.

2. The RF generator and the telemetry receivers are set to the desired frequency and the necessary manual patching is done.
3. The RF generator frequency deviation is set to the proper value as follows: The PCM data stream is connected to the programmable gain amplifier and the amplifier output is applied to the modulation input of the RF generator. This amplifier includes two 2-input NAND gates through which the PCM data passes. The amplifier gain is first set to unity (the gain of the amplifier can be set to any gain between 0.006 and

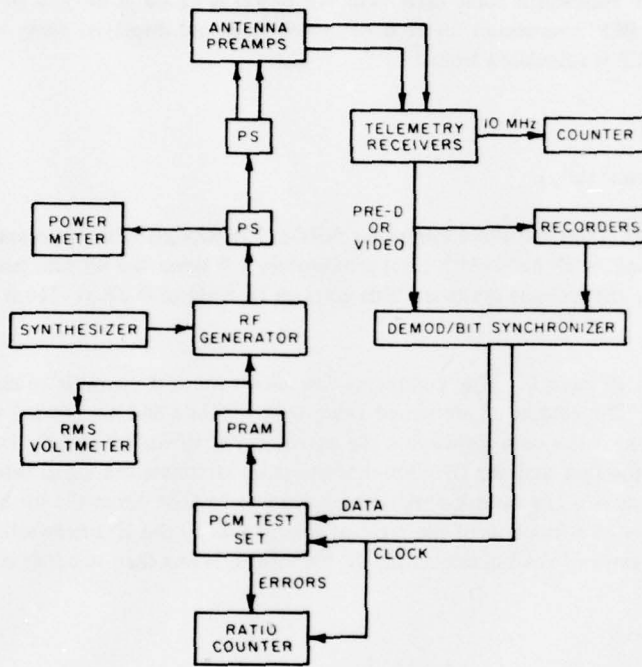

Figure 6. Bit Error Probability Test Configuration.

```

IS AN ANTENNA TO BE USED? (Y OR N) Y
TYPE ANTENNA NUMBER 1
WILL EXTERNAL EQUIPMENT BE TESTED? TYPE Y OR N: Y
FOR SCATS EXTERNAL INPUT 2

ENTER DATA TYPE:
  0 = VIDEO.
  1 = PRE-D 450.
  2 = PRE-D 900. 0
ENTER RECEIVER I.F. BANDWIDTH(KHZ) 1500
ENTER EXTERNAL RECEIVER NUMBER USED WITH INPUT 2: 99
ENTER CHANNEL NUMBER (1, 2, OR 3 FOR COMBINED): 1
WILL AN EXTERNAL TAPE RECORDER BE USED WITH INPUT 2? TYPE Y OR N: N
CABLE LOSS= -72.90 NOISE FIG.= 3
RF POWER STEP, IN DB: 1
INPUT 2 -RECEIVER 99 CH 1
  
```

Figure 7. Bit Error Probability Test Data Entry.

1.0 by the following formula, $\text{gain} = 0.995^X$; $0 < X < 1023$). The data output is set to the high state and the RF frequency is counted. The data output is then reset to the low state and the RF frequency again counted. The gain of the amplifier is then set to the ratio of the desired peak-to-peak frequency deviation to the difference between the above counter readings. The deviation is checked by setting and resetting the data output and determining the actual frequency deviation. If it is within a predetermined tolerance, the test continues; if not, a new gain is calculated and the deviation is again checked, etc.

4. The necessary interconnections to measure the BEP are made and the RF generator is set to a power level which should produce no errors. The error probability is measured and the test continues if the BEP is less than 10^{-5} . If there are too many errors an error message to that effect appears and the test is stopped until the problem is corrected.
5. If the system passes the initial BEP test, the RF power is set to give about a 13 dB IF SNR for a specified system noise temperature and the IF bandwidth being used. The RF power is varied in integral steps (step size determined by operator). The BEP is measured for each RF power level and displayed along with the theoretical BEP. The theoretical BEP is calculated from:²

$$\text{Theoretical BEP} = 0.5 e^{-\rho} \quad (4)$$

where ρ = IF SNR (expressed as power ratio).

This equation is only an approximation but is quite accurate for NRZ-L FM formats with optimum frequency deviation ($\Delta f \approx 0.35$ times the bit rate) and an IF bandwidth of approximately 1.5 times the bit rate (see figure 8). A noise figure of 3 dB is assumed for the antenna systems. This gives an IF SNR of 0 dB at -114.0 dBm when using a 1.0 MHz IF bandwidth.

A sample BEP test output is shown in table 11. The comments line allows the test operator to enter any supplemental information about the test. The comments are stored along with the data and are printed when the data is recalled from storage. Examination of this data shows that the experimental values are slightly better than the theoretical values. This is caused by the fact that the IF filter characteristics attenuate the signal sidebands more when the bit rate to IF bandwidth ratio is large (peak deviation assumed to be 0.35 times the bit rate). Therefore, the theoretical equation changes as a function of the ratio of the bit rate to the IF bandwidth. A better equation for conditions where the ratio of the bit rate to the IF bandwidth is less than one-half is:³

$$\text{Theoretical BEP} = 0.35 e^{-\rho} \quad (5)$$

Figure 9 shows the two theoretical curves overlaid on BEP test results with bit rate to IF bandwidth ratios of 0.25, 0.5, 0.75, and 1.0. Table 12 compares the IF SNR calculated from the measured system noise temperature (310° K) and from the measured BEP using equation (5). The IF SNR's calculated from the noise temperatures and from the BEP data agree within 0.3 dB.

The absolute accuracy of the BEP test is better than ± 0.5 dB and the short term repeatability is about ± 0.1 dB (for 100 or more bit errors per measurement interval). The time it takes to run a BEP test is a function of the RF power step size and the ratio of the bit rate to the measurement interval in bits. A typical BEP test can be performed in three minutes or less. The PCM test set output can also be connected directly to the PCM bit synchronizer to test the PCM subsystem alone.

²Mischa Schwartz, William R. Bennett, and Seymour Stein. "Communication Systems and Techniques," McGraw-Hill, New York, NY, 1966, p. 338.

³Nichols, M. H. "Analysis and Test Results of a Hybrid PCM/FM Subcarrier Baseband Multiplex on an FM Carrier," International Telemetry Conference, 1974, p. 230-6.

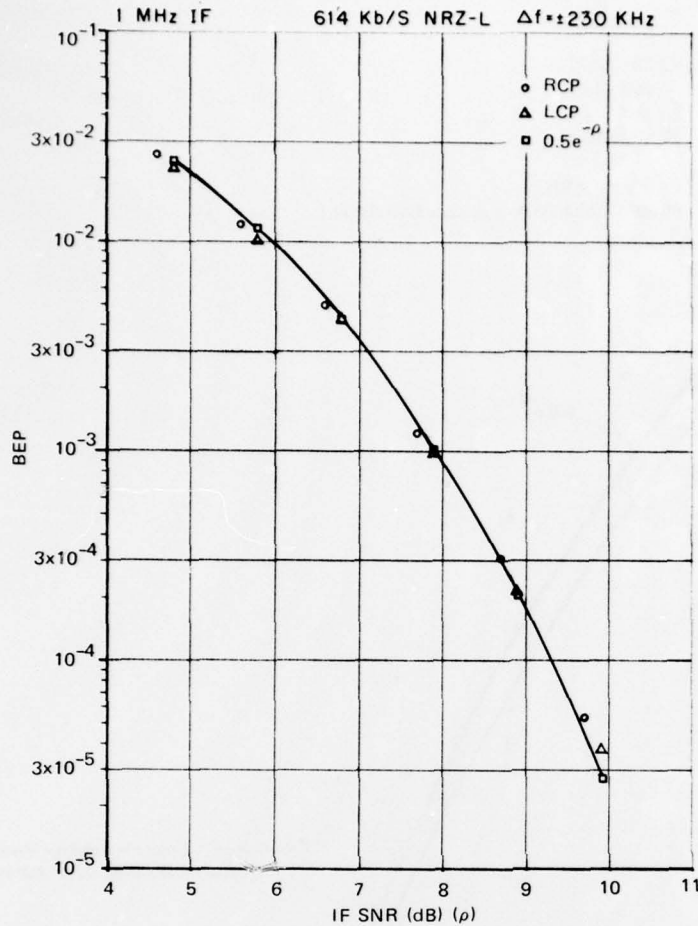

Figure 8. Bit Error Probability Versus IF SNR.

Table 11. Bit Error Probability Test Output

YEAR=79 JULIAN DAY=152 HOUR=22 MINUTE=43

BIT RATE: 615.7 KBS/SEC PEAK DEV: 227.7 KHZ CENTER FREQ:2250.5 MHZ
 I.F. BANDWIDTH: 1500 KHZ
 RECEIVER VIDEO

RECEIVER NUMBER 99 CHANNEL 1
 ANTENNA NUMBER 1

POWER (DBM.)	TEST RESULT	THEOR. (3 DB NF)
-107.6	2.25E-02	2.76E-02
-106.6	1.05E-02	1.29E-02
-105.6	3.99E-03	5.18E-03
-104.7	1.19E-03	1.61E-03
-103.6	2.55E-04	3.58E-04
-102.7	4.20E-05	6.21E-05
-101.7	7.00E-06	6.54E-06
-100.8	5.00E-06	3.93E-07
-99.8	0.00E-01	1.03E-08
-98.8	0.00E-01	1.29E-10

COMMENTS:

ARCHIVE DATA? Y

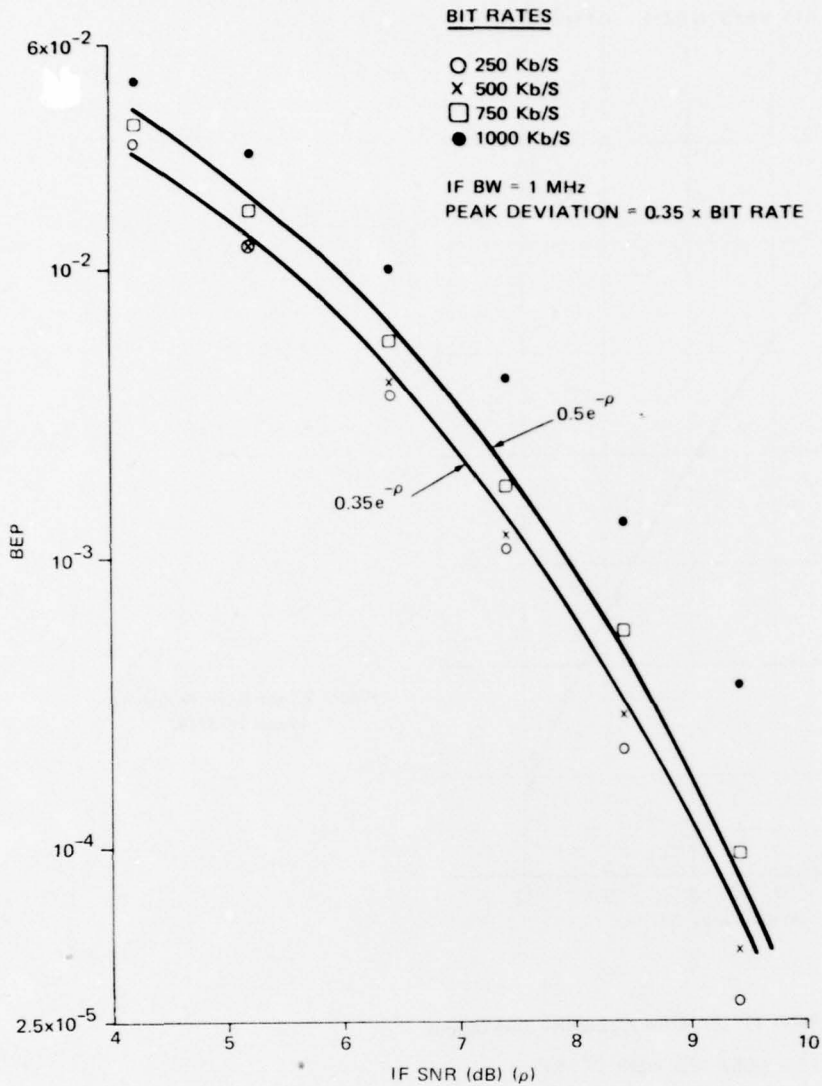

Table 12. Comparison of IF SNR Calculated From BEP Test Results With IF SNR Calculated From Measured Noise Temperature

RF Power (dBm)	Calculated IF SNR (dB)	
	From BEP Data	From Noise Temperature
-107.6	4.38	4.33
-106.6	5.45	5.34
-105.6	6.51	6.31
-104.7	7.55	7.30
-103.6	8.59	8.31

NOISE POWER RATIO TEST

This test measures the noise power ratio of the telemetry system under test. The noise power ratio is determined by the video SNR and intermodulation distortion at a particular frequency and can be used to estimate the data quality of an FM/FM multiplex.⁴ The noise power ratio test is very sensitive to certain types of nonlinearities and also to noise.

The telemetry system is tested using a noise generator and a noise receiver. The noise generator modulates the RF generator and video data is applied to the noise receiver. The noise generator has several notch (band-reject) filters and the noise receiver has narrow band-pass filters at the same center frequencies. A band-pass filter is selected and the power in the passband is measured. The matching notch filter is then inserted in the noise generator and the power in the passband is again measured. The ratio of these powers (expressed in dB) is the NPR. Next, the noise generator is turned off and the power in the passband is again measured. The ratio of the first power measurement to this power is called the noise power ratio floor (NPRF). This test displays the NPR and NPRF at predetermined frequencies in the video spectrum. The test conditions are entered by the same process used in the BEP tests.

The NPR test uses all of the SCATS equipment except the PCM test set (see figure 10). The rms RF frequency deviation is set by a procedure which is an extension of the RF deviation routine of the BEP test. The rms deviation is used because the rms voltage of a gaussian signal is easy to measure. The RF deviation routine sets the peak-to-peak frequency deviation of the RF generator equal to twice the desired rms deviation. The fact that the rms and peak of a two-valued waveform (where each value is equally probable) are equal is then used. The PCM data rate is set to 100 kilobits per second and the rms value of the RF generator modulation input is measured. The noise generator is then applied to the RF generator modulation input (the PCM is removed from

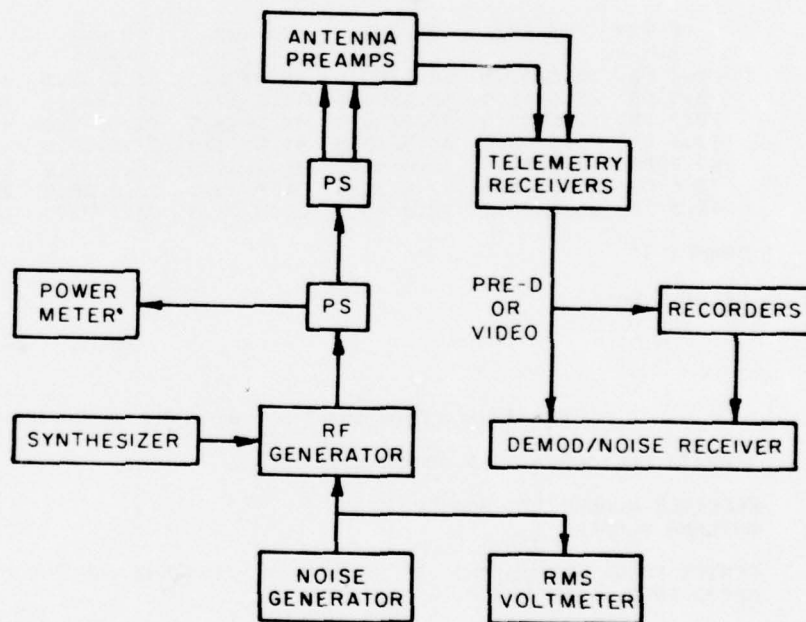

Figure 10. Noise Power Ratio (NPR) Test Configuration.

⁴ E. L. Law, E. T. Kimball, and M. H. Nichols. "Relationship of Noise Power Ratio to Subcarrier Discriminator Output Signal-to-Noise Ratio (Analysis of Test Results)," Pacific Missile Test Center, Point Mugu, CA. TP-75-21, 1 August 1975.

the modulation input) and the rms value of the noise is set equal to the rms of the PCM data. This sets the rms deviation with the noise equal to the peak deviation with the PCM as was desired. The RF generator is then set to maximum output power and the NPR and NPRF of the system under test are measured. Two RF power options are available for the NPR test:

1. Maximum RF power only.
2. RF power varied in 5 dB steps.

Table 13 shows a sample NPR test output with the RF power varied in 5 dB steps. The RF power for a 0 dB IF SNR is about -112 dBm. One of the important features of this test is that it can show how much noise and distortion a tape recorder is adding to the system. This is done by running NPR tests (at maximum RF power) on both the input and output of the tape recorder. Table 14 shows the NPRs at the input to the recorder and table 15 shows the NPRs at the output of the recorder. The NPRs at the recorder/reproducer output are 9- to 13-dB worse than the NPRs at the input. Since the NPR values are only about 1 dB lower than the NPRF values, the tape recorder noise dominates the distortion. Since the tape recorder SNR is in the neighborhood of 25 dB, the NPRs should be about the same as the NPRs at -88.8 dBm in table 13. They agree within 3 dB.

Table 13. Noise Power Ratio Test Output (5 dB RF Power Steps)

YEAR=79 JULIAN DAY=152 HOUR=22 MINUTE=13

RECEIVER NUMBER 99 CHANNEL 1
ANTENNA NUMBER 1

CENTER FREQ= 2250.5 MHZ IF BANDWIDTH= 1500 KHZ RF RMS DEV= 124.7 KHZ
RECEIVER VIDEO

NFR/NPRF (DB.)

RF PWR	16 KHZ	40 KHZ	70 KHZ	98 KHZ	140 KHZ	185 KHZ
-68.7 DB	53.5/62.5	50.5/55.5	48.0/51.0	46.0/48.5	43.5/46.0	42.5/44.5
-73.3 DB	53.0/61.5	50.0/53.5	46.5/49.0	45.0/46.5	42.0/43.5	41.0/41.5
-78.7 DB	52.5/59.0	48.0/50.5	44.5/45.5	42.0/43.0	39.0/39.0	37.5/37.5
-83.6 DB	51.5/55.0	44.5/45.5	41.0/41.0	37.5/38.0	35.0/35.0	32.0/32.0
-88.8 DB	48.5/50.5	40.5/41.0	36.5/36.5	32.5/33.0	30.0/29.5	27.5/27.5
-93.6 DB	45.0/45.5	37.0/36.0	31.5/32.0	28.0/28.5	25.0/25.0	23.0/22.5
-98.8 DB	40.5/40.5	31.0/30.5	25.5/26.0	23.0/23.0	20.5/20.5	17.5/17.5

COMMENTS:

ARCHIVE DATA? Y

Table 14. Noise Power Ratio Test Results at Recorder/Reproducer Input

YEAR=79 JULIAN DAY=155 HOUR=23 MINUTE= 6

RECEIVER NUMBER 99 CHANNEL 1
ANTENNA NUMBER 1

CENTER FREQ= 2250.5 MHZ IF BANDWIDTH= 1500 KHZ RF RMS DEV= 123.2 KHZ
PRE-D FREQ = 900 KHZ

NFR/NPRF (DB.)

RF PWR	16 KHZ	40 KHZ	70 KHZ	98 KHZ	140 KHZ	185 KHZ
-68.7 DB	54.0/61.0	50.0/53.5	46.5/49.0	43.5/46.0	41.5/43.5	39.0/41.0

COMMENTS:

ARCHIVE DATA? Y

Table 15. Noise Power Ratio Test Results at Recorder/Reproducer Output

YEAR=79 JULIAN DAY=155 HOUR=23 MINUTE= 6
 RECEIVER NUMBER 99 CHANNEL 1
 ANTENNA NUMBER 1
 TAPE RECORDER 3010 TRACK 2
 CENTER FREQ= 2250.5 MHZ IF BANDWIDTH= 1500 KHZ RF RMS DEV= 123.2 KHZ
 PRE-D FREQ = 900 KHZ

NPR/NPRF (DB.)						
RF PWR	16 KHZ	40 KHZ	70 KHZ	98 KHZ	140 KHZ	185 KHZ
-68.7 DB	45.0/45.5	39.5/40.5	34.5/36.0	32.5/33.0	29.0/29.5	26.0/27.0

COMMENTS:

ARCHIVE DATA? Y

The test data shown in table 13 took about 12 minutes to generate. The data shown in table 14 took about three minutes to generate. This is about one-fifth of the time it would take to perform the test manually. The test results can also be stored for later retrieval. The NPR is displayed in 0.5 dB increments and the accuracy is about ± 1.0 dB. The noise generator can be connected directly to the noise receiver to test the NPR subsystem. The results of a back-to-back NPR test are shown in table 16.

Table 16. Functional Noise Power Ratio Test Results (Back-to-Back Test)

YEAR=79 JULIAN DAY=159 HOUR=22 MINUTE=49

NPR/NPRF (DB.)					
16 KHZ.	40 KHZ.	70 KHZ.	98 KHZ.	140 KHZ.	185 KHZ.
74./ 79.	77./104.	78./105.	81./105.	77./105.	78./105.

TAPE RECORDER FREQUENCY RESPONSE TEST

SCATS can also measure the frequency response of a tape recorder/reproducer channel. First, the output of the function generator is connected to both the rms meter and the recorder input. The frequency is varied and the amplitude measured at each frequency. The rms meter is then connected to the reproducer output, the recorder is started and placed in record mode, the frequency is varied, and the recorder/reproducer output voltage is measured at each frequency. The ratio of the output voltage to the input voltage is calculated for each frequency. The frequency response is the ratio of the output/input ratio divided by the output/input ratio at 10 percent of upper bandedge. This is displayed in decibels along with the input frequencies and the input and output voltages. A sample tape recorder/reproducer frequency response output is shown in table 17.

INSTRUMENT TESTS

SCATS also has the capability of writing data to or reading data from each piece of test equipment. This is used for equipment troubleshooting. The instrument interface cards can also be written to and read by this routine. The interface had three integrated circuit failures in about 3,000 hours of operation. The problems

Table 17. SCATS TR FR Test Output

YEAR=79 JULIAN DAY=110 HOUR=18 MINUTE=23
 TAPE CHANNEL 2 PRE-D 900 TAPE SPEED 120

VOLTS			
FREQ(HZ)	INPUT	OUTPUT	OUTPUT/INPUT (dB)
400.	0.622	0.734	1.180
1000.	0.620	0.883	2.820
5000.	0.620	0.695	0.740
10000.	0.622	0.688	0.620
50000.	0.627	0.626	-0.280
100000.	0.628	0.623	-0.330
200000.	0.633	0.652	0.000
500000.	0.621	0.616	-0.330
750000.	0.591	0.558	-0.760
1000000.	0.552	0.515	-0.860
1400000.	0.477	0.467	-0.430
1800000.	0.414	0.390	-0.760
2000000.	0.402	0.314	-2.400

were quickly traced down and the bad integrated circuits found and replaced. There have been several failures of the commercial test equipment. There were two failures between 1 April and 31 December 1978. A relay in the attenuator driver of the RF generator failed and was replaced, and the rms meter failed and was replaced by the back-up unit. The 5-volt AC to DC power supply in the telemetry receiver failed in late July 1979. The receiver was kept operational by the substitution of a 5-volt laboratory power supply. SCATS has been quite reliable but additional spare equipment is needed to increase the probability of SCATS being available whenever it is needed.

CONCLUSIONS

The conclusions reached after analyzing the SCATS performance are:

1. SCATS provides a fast, accurate test of the operational status of telemetry ground station receiving and recording equipment.
2. The speed and accuracy advantages of automated testing over manual testing make automated testing very cost-effective in a "busy" telemetry ground station.

RECOMMENDATIONS

1. Systems similar to SCATS should be installed at all telemetry receiving and recording stations where fast, accurate tests of the station's operational status are necessary.
2. The IEEE-488 Interface should be used whenever possible. The system controller should be optimized for use with the IEEE-488 Interface.
3. Spares should be available for all essential equipment.

REFERENCES

1. Range Commanders Council IRIG Document, 118-73, Revised July 1975, "*Test Methods for Telemetry Systems and Subsystems*," Secretariat, White Sands Missile Range.
2. Mischa Schwartz, William R. Bennett, and Seymour Stein. "*Communication Systems and Techniques*," McGraw-Hill, New York, NY, 1966, p. 338.
3. Nichols, M. H. "*Analysis and Test Results of a Hybrid PCM/FM Subcarrier Baseband Multiplex on an FM Carrier*," International Telemetry Conference, 1974, p. 230-6.
4. E. L. Law, E. T. Kimball, and M. H. Nichols. "*Relationship of Noise Power Ratio to Subcarrier Discriminator Output Signal-to-Noise Ratio (Analysis of Test Results)*," Pacific Missile Test Center, Point Mugu, CA. TP-75-21, 1 August 1975.

APPENDIX A
INTERFACE BETWEEN MINICOMPUTER AND TEST EQUIPMENT

GENERAL DESCRIPTION

Communications between the Digital Equipment Corporation (DEC) PDP-11 minicomputer and the instruments is via an in-house designed and fabricated "Port Expander" interface. A standard DEC DR11-C General Purpose Parallel Interface Card is installed in the computer, which provides a single 16-bit parallel digital input/output port plus some status and control signals (bits). The Port Expander expands this to a maximum of 256 16-bit parallel TTL-Compatible interface ports, each with its own interrupt and trigger-out signals, arranged in a 16 x 16 matrix structure. Physically, these ports are small individual printed cards, called register cards, which are installed in a rack-mounted card cage. Standard test instruments with TTL interface capability (BCD, binary, or otherwise) can then be interfaced to these register cards. By this approach, the computer can communicate with a large number and wide variety of test instruments, and unique interfaces are physically removed from the restricted space of the computer mainframe.

The Port Expander is thus a large digital, two-way multiplexer between many instruments and one computer. The following were primary goals in the design of the Port Expander:

- Easy expansion capability.
- Ability to interface to a wide variety of test instruments, including relays.
- Fast response to any register card in the matrix.
- Ability to detect errors.
- Easy repair of any failures.

The Port Expander can be implemented as a full 16 block, 16 cards-per-block (total of 256 cards) matrix, or any subset (fewer blocks, partial blocks). A partial matrix can be built initially, and can be expanded at any later time. All register cards are identical and may interface directly to the instrument, or via Instrument Interface Cards (IIC's), for which there is also room in the card cage. The IIC's are individually designed for any unique requirements, such as high current drive, level changes, or inversions, etc. There are two features in the Port Expander of special interest: the Interrupt Request (IREQ) system and the Interrupt Read Gate (IRG) system. The IREQ system provides a hardware vectored interrupt from any register card in the matrix in equal time, and includes a stack for multiple interrupts. Thus, no software polling is required, and every interrupt is handled with equal response time. The IRG system provides a hardware check on addressing and reading data from the register cards. It continuously monitors those operations, and raises a flag to the computer if and only if there is an error; otherwise, the IRG system is transparent and causes no delay to the Port Expander operation. Because the Expander is modular in design, the register cards are identical, and error detection is built into the system, any failures are easily located and repairs are usually in the form of card swapping.

Two Port Expander systems have been built, and have been in continuous operation since 1976. They are the Automated Test System (ATS) in the Instrumentation Division, Code 1174, and the Self-Check Automated Telemetry System (SCATS) installed in the PACMISTESTCEN's operational telemetry receiving and recording station located in Building 738. Their operation has demonstrated a high degree of reliability and the attainment of all design goals.

BLOCK DIAGRAM DESCRIPTIONS

Figure A-1 is an overall block diagram of the Port Expander system, and applies to both ATS and SCATS. ATS is a larger implementation, consisting of five blocks contained in two card cages; SCATS presently consists of three blocks within one card cage, but can be expanded if necessary as noted above. The Master Control is a large printed circuit board assembly located in one of the card cages. The DR11-C I/O Card is located within the PDP-11 computer, and communicates with Master Control via two 40-conductor flat cables (Connectors #1 and #2). The Master Control communicates with the register cards via the various signal paths (READ Bus, WRITE Bus, etc.) which will be described below. Not shown in this diagram are the test instruments, which would be outside the card cages. Communication with them is via cables between the cages and individual instruments.

Figure A-2 describes the Master Control section, which handles all communications between the DR11-C and the register cards. The DR11-C I/O card provides the following signals:

Output

- 16 data output bits
- 2 programmable control bits (CSR0 and CSR1)
- New Data Ready (NDR) pulse (data ready on output lines)
- Data Transferred (DT) pulse (input data accepted)
- A Reset signal (INIT)

Input

- 16 data input bits
- 2 interrupt lines (REQ A and REQ B)

Under software control, the output bits contain two types of information at different times: data to be sent to a register card, and the register card address (in the lower 8 bits only). The input bits contain data coming in from a register card. The control bits (CSR0 and CSR1) are used in conjunction with the data pulses (NDR and DT) to form internal control signals which steer the data to the proper places at the proper times. The four basic operations defined from the viewpoint of the Port Expander, and the control signals they use, are as follows:

- Write operation - Master Data Register Enable (MDRE) and Write Command (WC)
- Read operation - Read Gate (RG) and Quiet (QT)
- Trigger operation (provides a trigger pulse out from an addressed Register Card) - Trigger (TR)
- Reset (clears all Register Cards) - Master Reset (MR)

Figure A-3 details the timing and control for the first three operations; Reset is immediate upon transmission of the INIT signal from the computer, or if the manual reset button is pushed.

In the Write operation, the first output word is the data, which is stored in the Master Data Register, whose output is buffered and sent to the register cards. The second output word is the coded address information (4 bits for Block Address, 4 bits for Card Address) which is applied to the dual 1-of-16 Address Decoder and sent to the register cards, which are logically arranged in an X-Y matrix, as Block Selects and Card Selects. The WC pulse actually loads the data into the selected register card. In the Read operation, the address information is sent out to the Address Decoder, the RF pulse is transmitted, causing the selected register card to apply its data to the input lines, the computer accepts the data, and the QT pulse is sent to signify the end of the operation. In the Trigger operation, the address information is decoded and the TR pulse is transmitted, which causes the selected register card to output a trigger pulse.

The two signals, Interrupt Request (IREQ) and Interrupt Read Gate (IRG), are active only during the Write and Read operations. Whenever a register card is written to, it causes the IREQ signal to go true. This activates the IREQ system which raises REQ A to the computer and loads a "vector," or address of the card which was

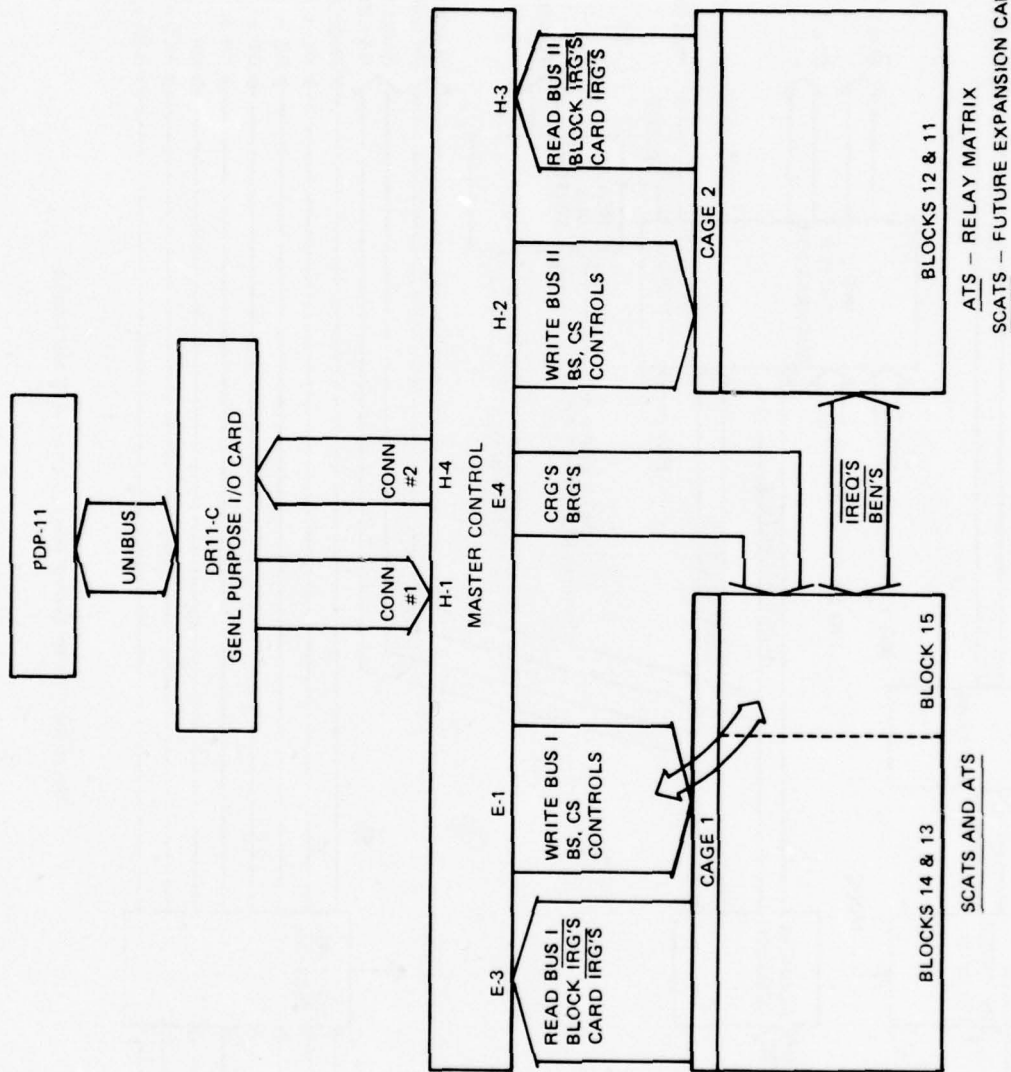

Figure A-1. Port Expander Block Diagram/Interconnections.

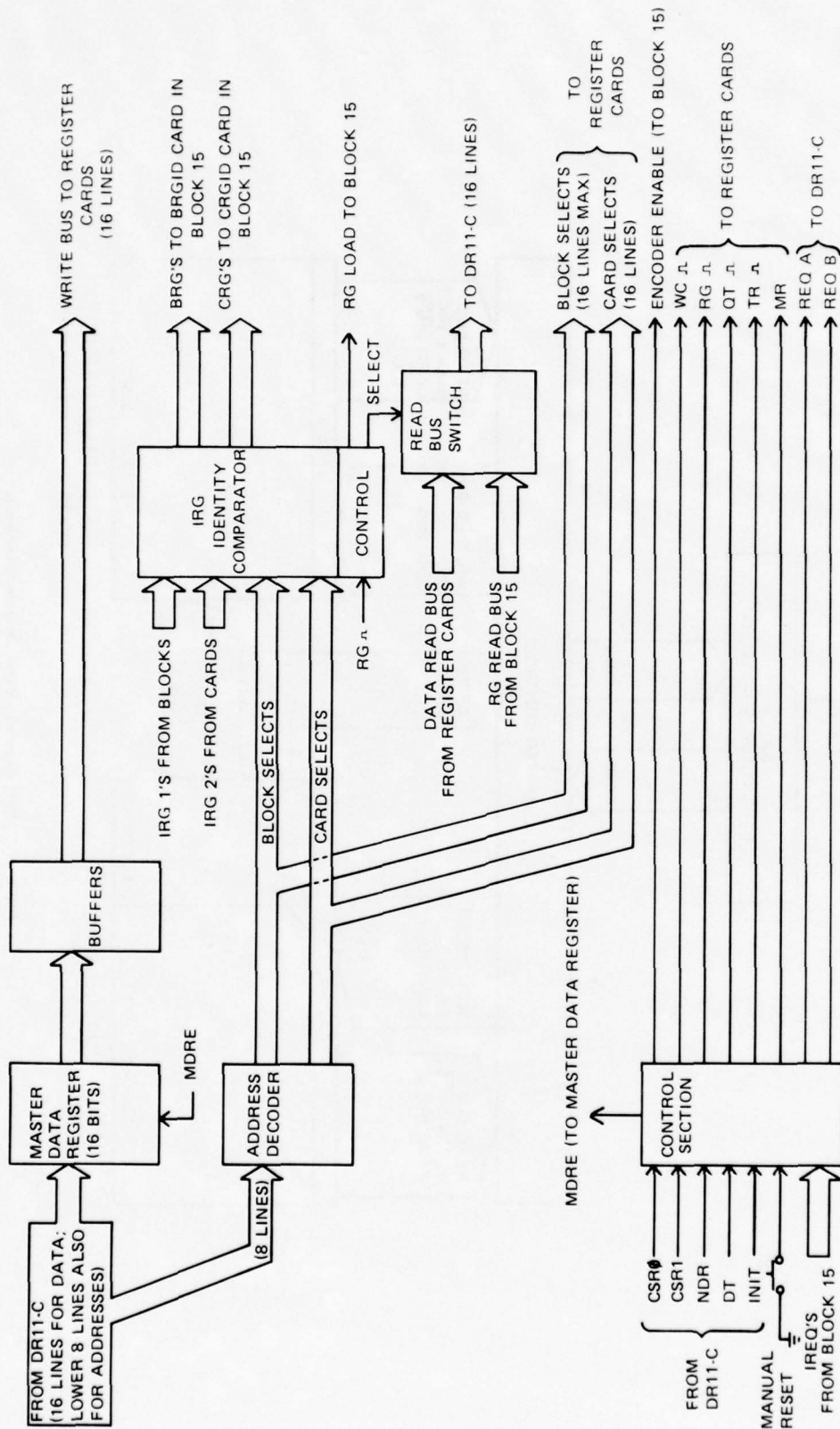

Figure A-2. Master Control Block Diagram ATS and SCATS.

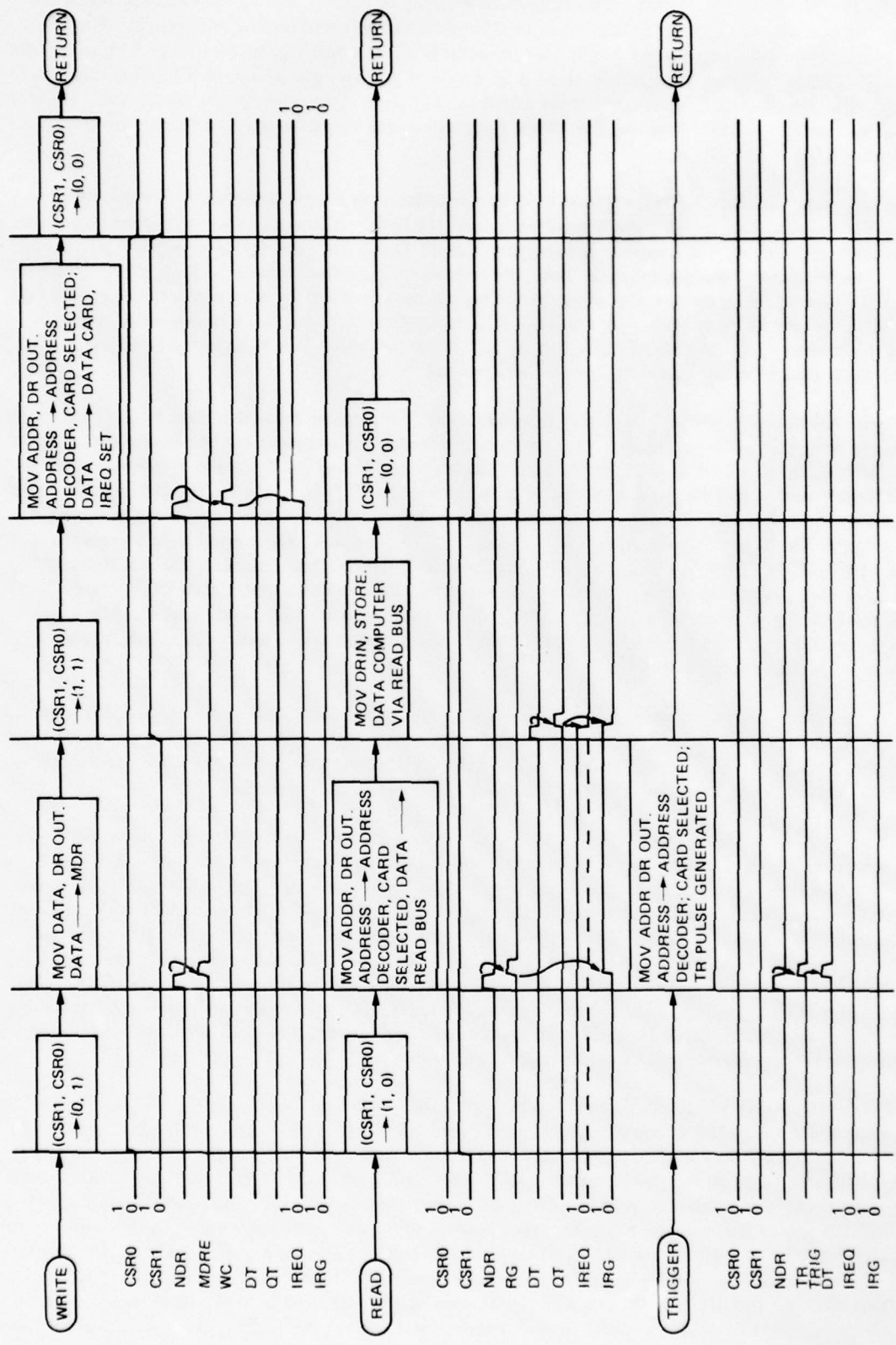

Figure A-3. Master Control Card Timing Diagram.

written to, into a special register card. (This system will be detailed below.) During the Read operation, the IRG signal is asserted, which gates the data onto the Read Bus, and also activates the IRG system. The IRG system compares the Address Decoder output with the address of the actual register card being read, as encoded from the IRG signals. If they are identical, there is no action; if not, an error is implied, REQ B is raised to the computer, and under software control, corrective action can be taken. Two other special register cards are loaded with read gate vectors to assist in this action. When a successful read operation is accomplished, the QT signal clears both the IREQ and IRG signals.

An important corollary to the definition of these operations is that every Write must be followed by a Read, due to the fact that the QT pulse is required to clear the IREQ. There are two sources from which the register cards receive data: the computer and the instruments. In the first case, the computer is sending information to an instrument via a register card. Here, the mandatory Write-Read sequence allows the computer to compare the data sent with the actual contents of the register card to check for any errors. In the second case, an instrument is sending data to the computer via a different register card, and this External Write operation informs the computer (via the IREQ-REQ A signals) that data is available. This initiates the Read operation, whereby the computer receives the data from the register card.

Figure A-4 illustrates the register card architecture. The card contains a 16-bit storage register, two 16-bit buffers, and some control logic. Input to the register is from either the computer (via the Master Data Register in the Master Control section) or from an instrument, depending on the application. The upper buffer, always enabled, follows the register output and is used to drive instruments, IIC's, relays, etc. The gated buffer output is enabled by the IRG signal only during a Read operation, and is used to send data back to the computer via Master Control. Both buffers have active low, open-collector TTL outputs. The control logic accepts the commands WC, RG, QT, and TR only when its select lines (BSX and CSX) are asserted. The MR command is overriding at all times. If the register card is used to accept data from an instrument, then WC is not used; instead, the EXT input accepts a load command from the instrument to asynchronously load the data into the register, independent of the select lines. The control logic also generates the necessary IREQ and IRG signals, plus the selected TRIG signal output.

The next four diagrams (figures A-5 to A-8) illustrate how the various signal paths are routed through the Port Expander matrix. Figure A-5, Register Card Addressing, shows how the Block Selects are connected to all cards within a block to which the computer writes, and the Card Selects connect across the blocks. Note that when an instrument writes to a card, the EXT input is used instead of BSX and CSX.

In figure A-6, the data paths (Write Bus and Read Bus) are shown. The Write Bus goes from Master Control to all register cards to which the computer writes data; those cards to which instruments write are not on the Write Bus. However, all register cards are on one of two types of Read Busses. The BRGID (Block Read Gate Identification) and CRGID (Card Read Gate Identification) cards in Block 15 are on a special RG (Read Gate) Read Bus which is accessed in Master Control only when the IRG system detects an error while reading data from somewhere else in the Port Expander matrix. All other cards are on the Data Read Bus. The wired-OR Read Bus connects the open-collector outputs of the register cards and is collected in the buffer section of the encoder/buffer cards at the top of each block. The wired-OR ENC/BUF card outputs are then collected in the Master Control section. In Block 14, there is an example of a register card connected simultaneously to the read bus and to an instrument, using the two output ports available.

The wired-OR read bus allows easy expansion of the Port Expander system; however, if more than one register card is gated onto the Bus at any given time, invalid data will result. For that reason, the IRG system was developed, and figure A-7 illustrates its connections. The (open-collector) $\overline{\text{IRG1}}$ signals on the register cards are collected across all cards within a block and sent to Master Control, while the $\overline{\text{IRG2}}$'s are collected from the N'th card across all blocks and also sent to Master Control. These are converted to the BRG and CRG signals and sent to the BRGID and CRGID cards in Block 15. They are also compared, in Master Control, to the output of the Address Decoder, which contains the address of the card selected for the Read operation. If they are identical, no action occurs, thus causing no delay to the Port Expander operation. However, if the comparison fails then the RG LOAD loads the BRGID/CRGID cards with the location of all cards gated onto the Read Bus, and interrupts the computer via REQ B. Under software control, the isolated RG Read Bus is then read, and corrective action can then be taken.

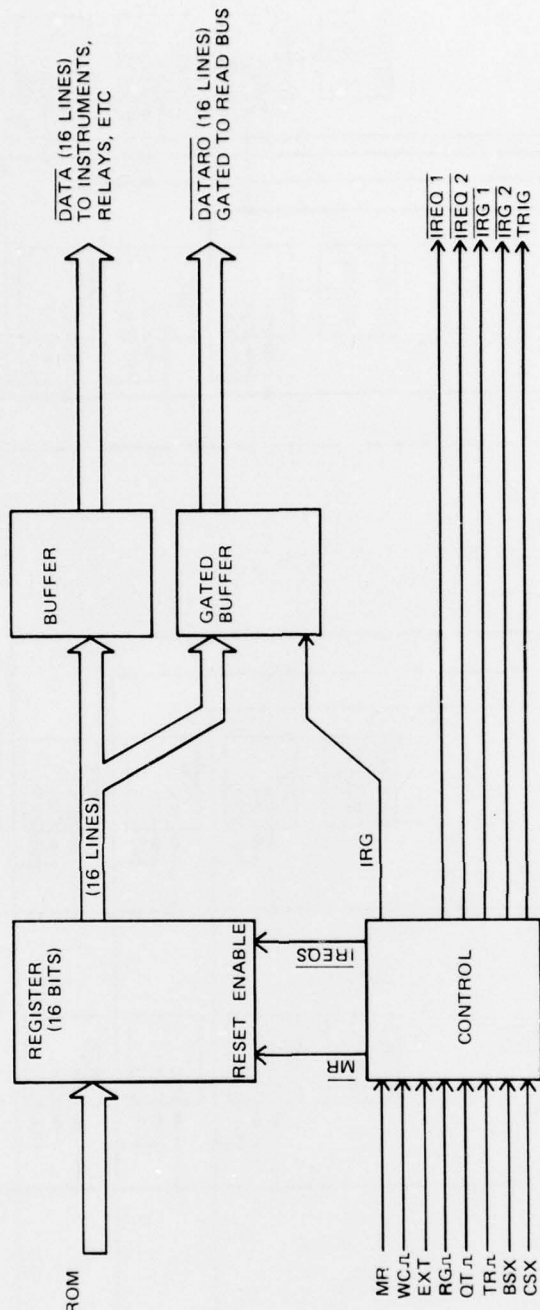

Figure A-4. Register Card Block Diagram.

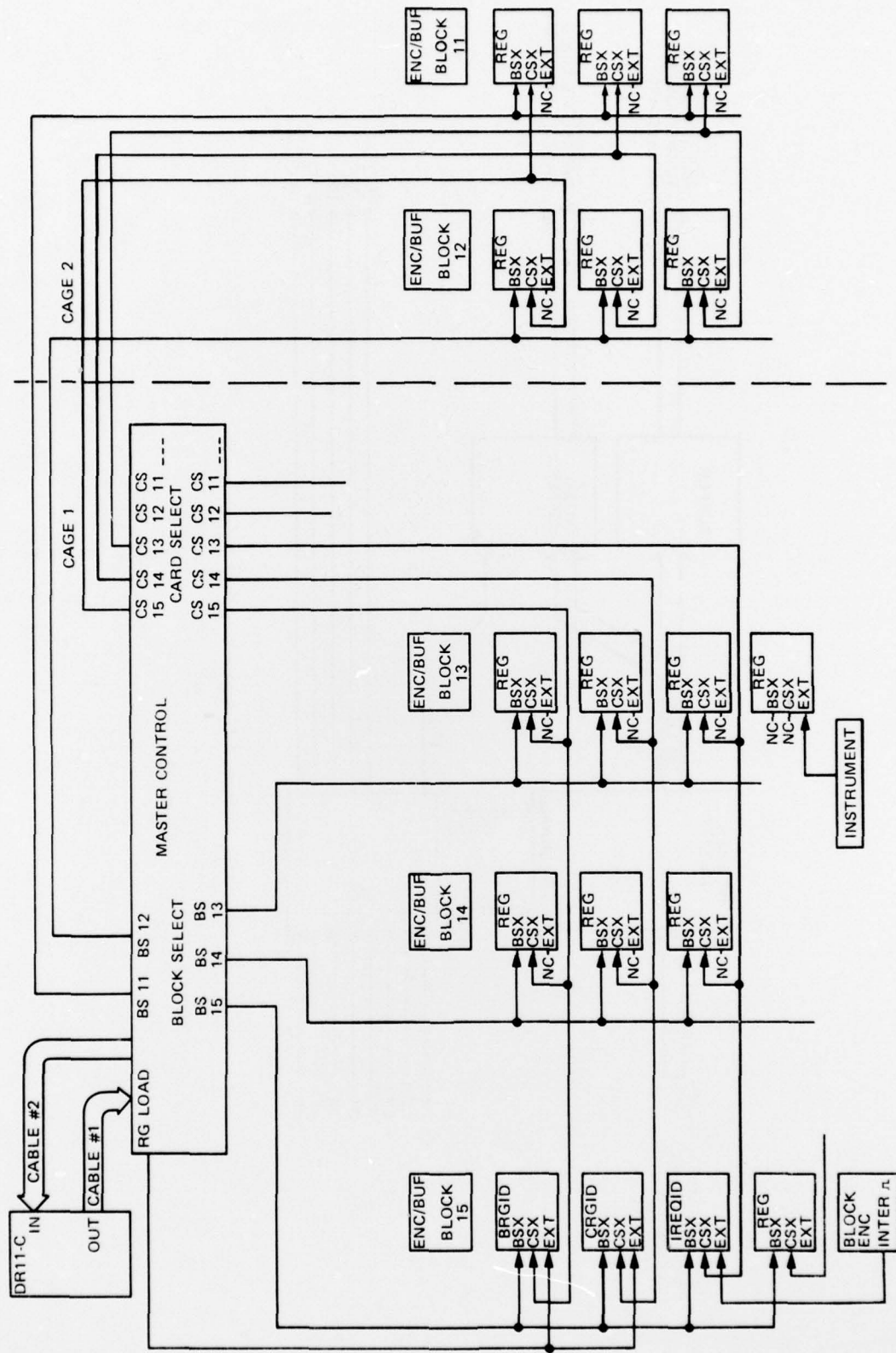

Figure A-5. Register Card Addressing.

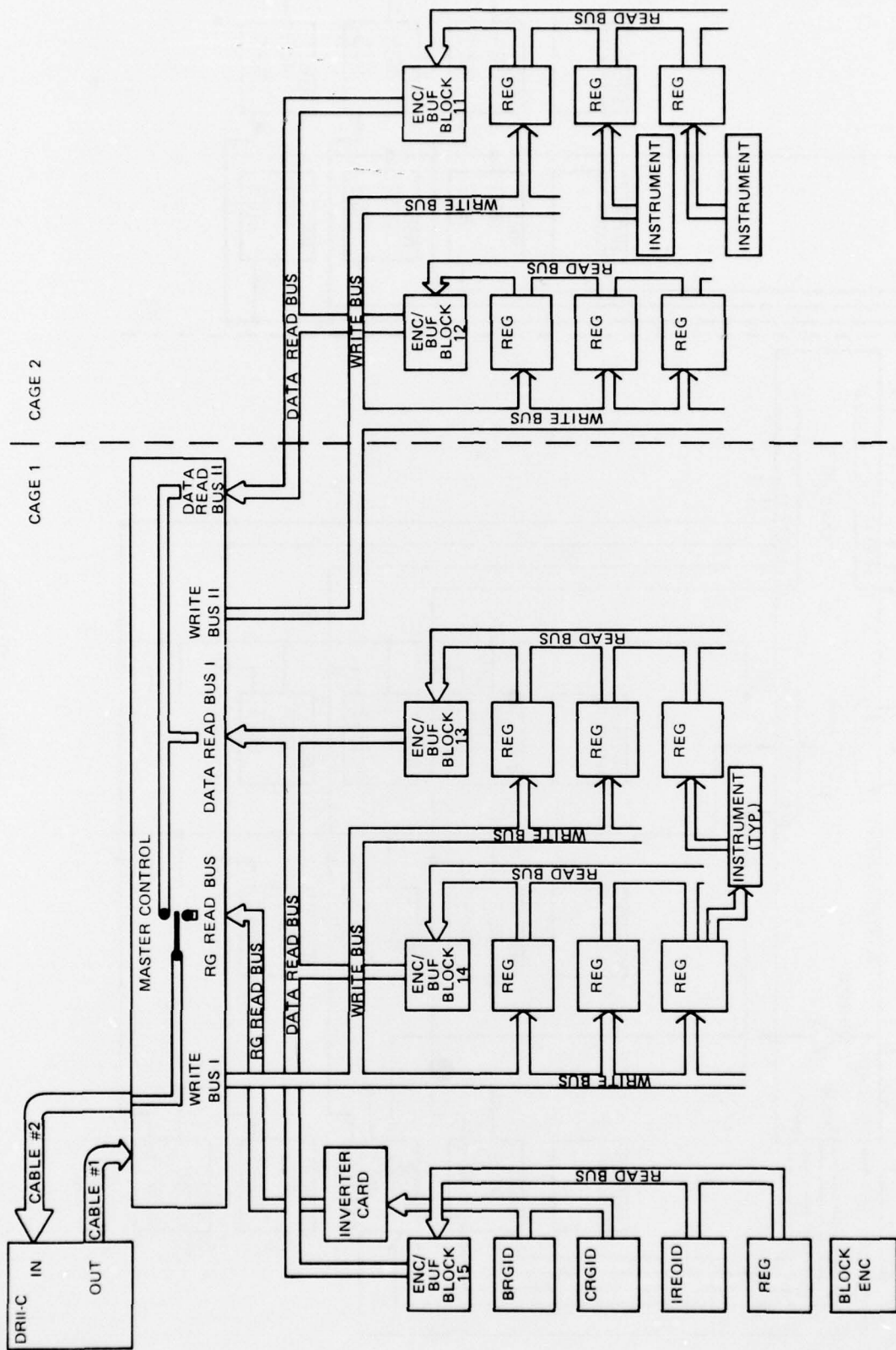

Figure A-6. Routing, Read Bus/Write Bus.

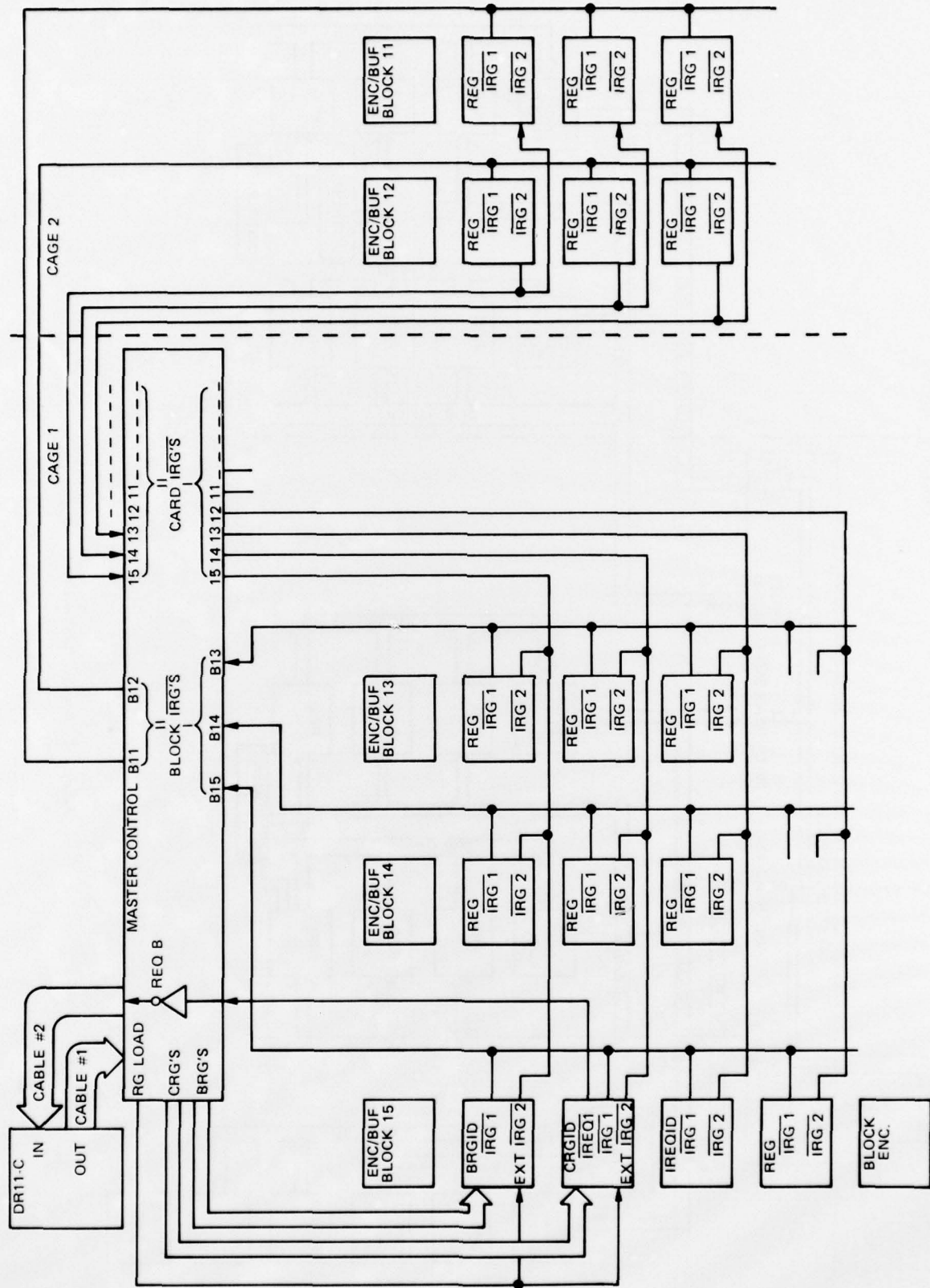

Figure A-7. IRG System.

The IREQ system provides a hardware vectored priority interrupt system with equal response time from any register card, with no software polling required. Figure A-8 shows the system interconnections, and figure A-9 details the system operation on a simplified (two block, two cards per block) Port Expander system. Similarly to the IRG system, the $\overline{\text{IREQ1}}$'s are collected across the blocks and sent to the special Block Encoder card in Block 15. The $\overline{\text{IREQ2}}$'s are collected at the Encoder/Buffer card within each block, and encoded onto the IREQ Address Bus, which also goes to the Block Encoder card, along with a Group Signal ($\overline{\text{GS}}$). When a register card is written to, either from the computer or from an instrument, its $\overline{\text{IREQ1}}$ is encoded to the block number in which the card resides, the Block Enable ($\overline{\text{BEN}}$) signal is sent to the ENC/BUF card of the proper block, which enables the $\overline{\text{IREQ2}}$ to be encoded to the card number and applied via the IREQ Card Address Bus to the Block Encoder card. The $\overline{\text{GS}}$ then triggers a one-shot, which loads the encoded block and card number into the IREQID card, whose $\overline{\text{IREQ1}}$ signal interrupts the computer via REQ A. This entire operation sounds quite involved, but actually occurs in less than one microsecond (10^{-6} sec.). In order to acquire data from the register card, the computer would first read the IREQID card, whose contents are the address of the register card (or vector), and then read the vectored register card. Due to the type of circuits used in the IREQ system, higher block numbers have higher priority than lower block numbers (i.e., will be serviced first in the case of simultaneous interrupts), and likewise, higher card numbers have higher priority within a block. Note that the highest priority goes to the BRGID/CRGID cards, followed by the IREQID card, and then all other register cards. Figure A-9 presents a simplified schematic diagram of the IREQ system, along with a flowchart of the operation sequence. In the event of multiple interrupts, the highest priority is serviced first while the others are held at the Register Card IREQ's until serviced. Thus, an interrupt "stack" is effectively formed within the IREQ system.

PHYSICAL DESCRIPTION

The Port Expander consists of one or more rack-mounted card cages. The Master Control section is a large printed circuit (P. C.) board assembly mounted on the top of the first card cage. The register, ENC/BUF, Block Encoder Relay and Instrument Interface Cards (IIC's) are all 4.5" by 6.5" P.C. boards with 72 pin edge connectors. The card cage has a wire-wrapped backplane. On the back of the cage are electrical connectors, from which cables go to the instruments. The two 40-conductor flat cables between the computer and Port Expander and the cables to the instruments can be up to approximately 25 feet long.

In the ATS, a special relay card has been designed which contains sixteen TTL-compatible SPST reed relays, with all relay contacts available on the edge connector and provisions for jumper wires on the card. A large number of these have been interconnected in a separate card cage, and driven directly by the register cards, to form a large computer controlled crossbar relay matrix for switching analog signals between the test instruments and the Unit Under Test (UUT).

Some instruments are designed to accept active low TTL control signals, and even have internal pull-up resistors. These instruments can be interfaced directly to the register card outputs. Others require different logic levels, increased drive, or special formatting. In these cases, the register cards interface to the instruments via the IIC's which are individually designed for each specific application.

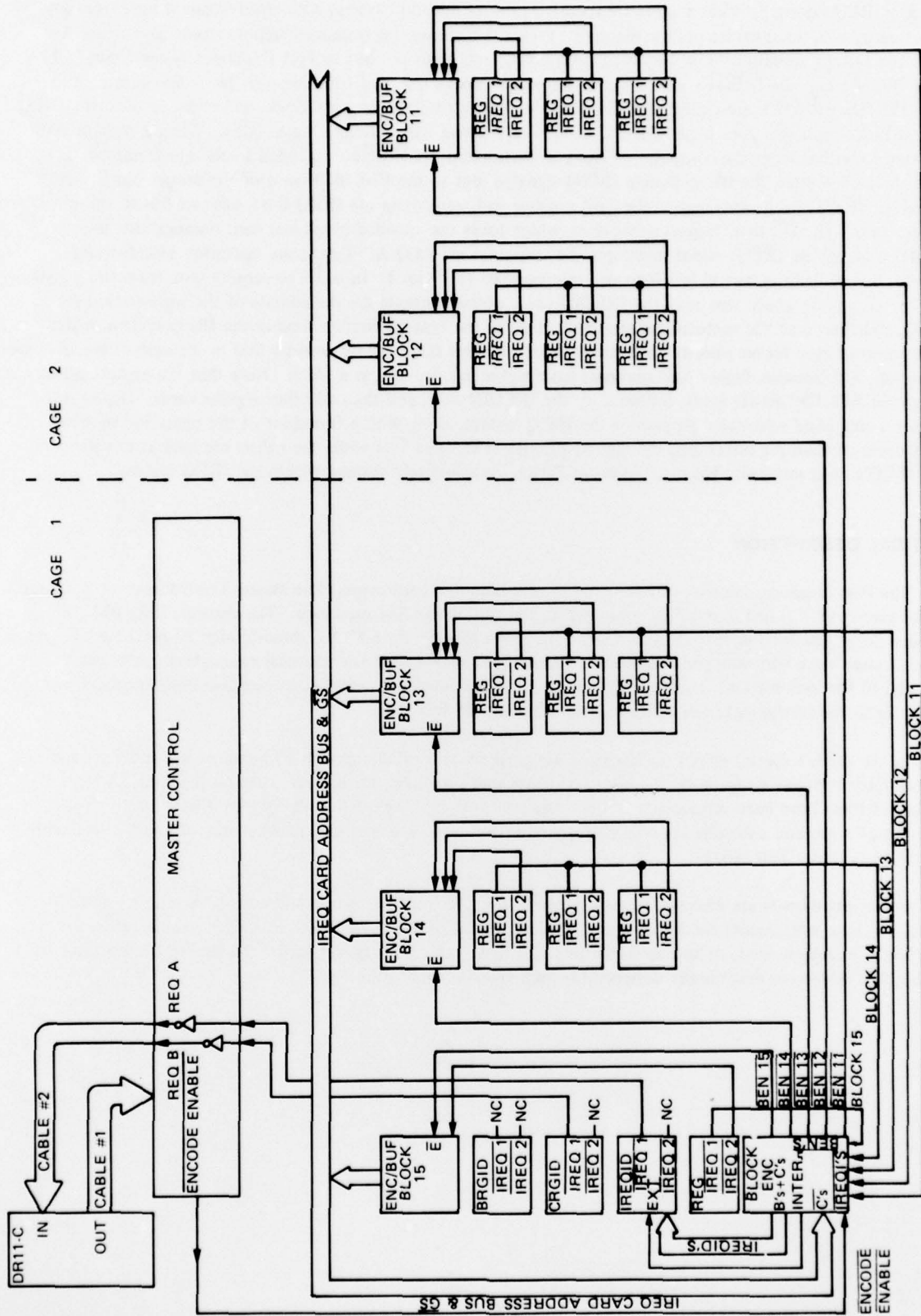
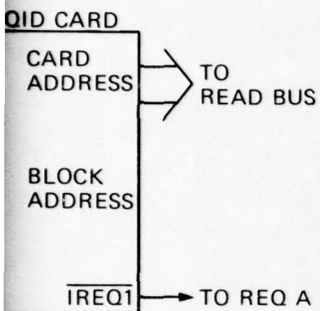

Figure A-8. IREQ System.

$\overline{\text{IREQ}}$ OUTPUTS AND * OUTPUTS ARE
 IN COLLECTOR.
 RESISTORS TERMINATE TO +5 VOLTS.
 HIGHEST NUMBERED BLOCK HAS PRIORITY;
 HIGHEST NUMBERED CARD WITHIN BLOCK
 HAS PRIORITY.
 FLOW CHART FOR OPERATION.
 CS0, CS1, CS2, CS3 ARE 74148 PRIORITY ENCODER;
 CS4 IS 9311 A 4 - TO - 16 DECODER.



CS0 ACTIVATES $\overline{\text{IREQXX}}$

$\overline{\text{IREQ}} = (\overline{\text{CS0}} \cdot \overline{\text{CS1}}) = (\text{CS0} + \text{CS1})$ WILL
 TURN OFF INTERRUPTS BY DISABLING 74148 UNTIL
 INTERRUPT SERVICE COMPLETES. THEN $\overline{\text{IREQ1XX}}$ GOES
 HIGH. CS0 ENCODER; CS1 ENABLES 9311 WHICH ENA-
 BLES 9311 CARD ENCODER IN THAT BLOCK TO FORM CARD
 ADDRESS. CS2 CAUSES BLOCK AND CARD ADDRESS TO
 BE ADDED INTO $\overline{\text{IREQID}}$ CARD.

ON $\overline{\text{IREQID}}$ CARD RAISES REQ A TO COMPUTER.

CS1 SETS CS1 TO INHIBIT OTHER INTERRUPTS,
 SENDS ADDRESS TO COMPUTER VIA READ BUS AND
 RAISES REQ A.

CS1 IS MAINTAINED ACTIVE HERE TO PRE-
 VENT OTHER INTERRUPTS DURING AN INTERRUPT SERVICE
 OPERATION.

CS2 STILL INHIBITS OTHER INTERRUPTS; THEY ARE
 HANDLED ON THE DATA CARD.

Figure A-9. IREQ System Simplified Operation.

2

INITIAL DISTRIBUTION

EXTERNAL	Copies	EXTERNAL	Copies
Commander Naval Air Systems Command Headquarters Washington, DC 20361 Attn: AIR-954	2	Officer-in-Charge Fleet Analysis Center Naval Weapons Station, Seal Beach Corona, CA 91720 Attn: Code 84	1
Defense Documentation Center Cameron Station Alexandria, VA 22314 Attn: TIOG	12	Code 85 Code 854 Code 8541 (B. P. Wagner) Code 8543	1 1 1 1
Commander Naval Sea Systems Command Headquarters Washington, DC 20362 Attn: SEA-6541	1	Director Mobile Sea Range Port Hueneme, CA 93041 Attn: PMS 404-70	1
SEA-6542	1	Commander Naval Air Systems Command Target and Range Division Point Mugu, CA 93042 Attn: AIR-630	1
SEA-6543	1	AIR-630C	1
SEA-06N	1	AIR-6302E	3
Commander Naval Weapons Center China Lake, CA 93555 Attn: Code 3060	1	DDR&E AD TR The Pentagon Washington, DC 20301 Attn: D. Greenlee	1
Code 6213	1	Commanding Officer Naval Ordnance Missile Test Facility White Sands Missile Range, NM 88002 Attn: Code 503 (W. W. Bohn)	1
Code 6242	1	Commander White Sands Missile Range, NM 88002 Attn: STEWS-ID-DH (A. Gavay)	1
Code 6243	1	STEWS-ID-DT (C. Malone)	1
Commanding Officer Naval Avionics Center Indianapolis, IN 46218 Attn: Code 906	1	STEWS-ID-S (E. Bejarano)	1
Code 811 (J. Brining)	1	(P. Sharp)	1
(K. Burgess)	1	STEWS-ID-IT (B. Chin)	1
Commander Naval Air Test Center Patuxent River, MD 20670 Attn: Code TS21 (W. D. Anderson)	1	Commanding Officer Box 23, U.S. Naval Station Atlantic Fleet Weapons Training Facility FPO Miami, FL 34051 Attn: C. Wilks	1
Code TS02 (H. O. Norfolk, Jr.)	1		
Commanding Officer Naval Ship Weapon Systems Engineering Station Port Hueneme, CA 93043 Attn: Code 4521 (H. Morris)	1		
Code 6310 (L. Bates)	1		

EXTERNAL	Copies	EXTERNAL	Copies
AFTTC Edwards AFB, CA 93523 Attn: 6510 TESTW/TEESD, Stop 239 (J. Ramos, III)	1	ADTC Eglin AFB, FL 32542 Attn: 3246th TESTW/TEERS (E. J. Poschel)	1
6510 TESTW/TEEDO, Stop 200 (A. Yamaguchi)	1	3246th TESTW/TEEPE (R. W. Horne)	1
Commanding Officer Yuma Proving Ground Yuma, AZ 85364 Attn: STEYP-MDP (R. Gourley)	1	ADTC Holloman AFB, NM 88330 Attn: 6585th TESTG/TKI (C. Kern)	1
SAMTEC Patrick AFB, FL 32925 Attn: DET #1 ETR/TOEI (H. E. Beckner, Jr.)	1	USAAR&DC Dover, NJ 07801 Attn: DRDAR-TSI-T (L. H. Glass)	1
ADTC Holloman AFB, NM 88330 Attn: 6585th TESTG/TKIA (J. A. Haden, Jr.)	1	AFGL L. G. Hanscom Field Bedford, MA 01730 Attn: AFGL-LCR (R. Wilton)	1
AFSCF Sunnyvale AFS, CA 94086 Attn: Aerospace Corp., Bldg. 1003 (D. Stevenson)	1	SAMSO P. O. Box 92957 Aerospace Corp., Bldg. A-2, Rm 1077 Los Angeles, CA 90009 Attn: N. F. Lantz M. H. Nichols	1 1
SAMTEC/ROIS Vandenberg AFB, CA 93437 Attn: D. K. Manoa K. O. Schoeck	3 1	Lawrence Livermore Laboratories P. O. Box 808 Livermore, CA 94550 Attn: R. T. Hasbrouck	1
Test Squadron/TEJS Tyndall AFB, FL 32401 Attn: CAPT A. Hudson, USAF	1	Sandia Laboratories Kirtland AFB - East Division 1535 Albuquerque, NM 87115 Attn: R. S. Reynolds	1
Missile Research & Development Command Redstone Arsenal, AL 35809 Attn: DRSMI-RTA, Bldg. 7855 (R. D. Bibb)	1	Sandia Laboratories Division 1584, Box 5800 Albuquerque, NM 87115 Attn: H. O. Jeske	1
Commanding Officer U.S. Army Electronic Proving Ground Fort Huachuca, AZ 85613 Attn: STEEP-MT-I (W. T. Lyon)	1	National Aeronautics and Space Administration Goodard Space Flight Center Greenbelt, MD 20771 Attn: Code 730.4 (W. B. Poland, Jr.) Code 734 (R. M. Muller) (C. Tevathan)	1 1 1
ADTC Eglin AFB, FL 32542 Attn: Vitro Services (D. Crumpler)	1		

EXTERNAL	Copies	EXTERNAL	Copies
Sandia Laboratories Tonopah Test Range P. O. Box 871 Tonopah, NV 89049 Attn: Division 1172 (R. Beasley)	1	McDonnell-Douglas Astronautics 5301 Bolsa Avenue Huntington Beach, CA 92647 Attn: A3-833-BBSO (D. R. Andelin) A3-250-AG30 (R. M. Frahm)	1 1
NPTR El Centro, CA 92243 Attn: Code 331A (J. T. Doerr)	1	Federal Electric Corporation Vandenberg AFB, CA 93437 Attn: V. Shibota	3
National Bureau of Standards Washington, DC 20234 Attn: Division 425.03 (P. S. Lederer)	1	Grumman Aerospace Corporation Instrumentation PLT 6 Calverton, NY 11933 Attn: R. S. McElhiney E. Charland	1 1
National Bureau of Standards Magnetic Surfaces Laboratory Bldg. 225, Rm A-105 Gaithersburg, MD 20760 Attn: FSA-FSS (J. J. Fiori)	1	Harris Electronic Systems Division P. O. Box 37 Melbourne, FL 32935 Attn: C. Curry	1 1
AFFDL/FBG Wright-Patterson AFB, OH 45433 Attn: C. E. Thomas	1	Martin-Marietta Corporation P. O. Box 179 Denver, CO 80201 Attn: MS 8200 (C. M. Kortman) (S. Hurst)	1 1
University of Southern California Olin Hall, University Park Los Angeles, CA 90007 Attn: Dr. W. C. Lindsey	1	Teledyne Telemetry Company 1901 South Bundy Drive Los Angeles, CA 90025 Attn: H. F. Pruss	1
National Aeronautics and Space Administration 1520 H Street N. W. Washington, DC 20546 Attn: Code MF (W. E. Miller, Jr.)	1	Kentron International Box 1207 APO San Francisco 96555 Attn: Telemetry Supervisor	1
Marshall Space Flight Center Huntsville, AL 35811 Attn: Code S&E-ASTR-I (W. Threlkeld)	1	Kentron International 22003 Byrdspring Road Huntsville, AL 35802 Attn: C. Vernon	1
Boeing Company, ASG Systems Instrumentation and Telemetry Seattle, WA 98124 Attn: Org. 2-5180 MH 8H-07 (V. A. Jennings)	1	Commander Kwajalein Missile Range Box 26 APO San Francisco 96555 Attn: RKT-I	1
Jet Propulsion Laboratory 4800 Oak Grove Drive (156-142) Pasadena, CA 91103 Attn: R. Piereson	1		

EXTERNAL	Copies	INTERNAL	Copies
Microdyne Corporation 627 Lofstrand Land Rockville, MD 20850 Attn: G. Gallup	1	Commander PACMISTESTCEN Code 0000 RADM F. H. Baughman	1
Scientific - Atlanta Inc. 3845 Pleasantdale Road Atlanta, GA 30340 Attn: G. Rosenblatt	1	Technical Director Code 0002 Thad Perry	1
Harman Systems P. O. Box 3117 Anaheim, CA 92803 Attn: R. Catterlin	1	Project Management Group Code 0100 CAPT N. A. Deam Code 0141-1 M. H. Cain Code 0143 F. Ballinger	1 1 1
		Systems Evaluation Directorate Code 1001 CAPT R. L. Berg Code 1002 N. F. Rohn	 1 1
		Weapons System Test Department Code 1100 CAPT J. M. Hickerson	 1
		PATE Division Code 1142 E. F. Sandy	 1
		Electronic Warfare Division Code 1150 E. R. Hill	 1
		Weapons Instrumentation Division Code 1170 V. E. Orris Code 1171 M. Beckmann D. R. Hust C. M. Kaloi E. L. Law D. H. Rilling Code 1172 J. Hallerman E. T. Kimball D. R. Knight F. R. Hartzler	 1 1 1 1 30 1 1 1 1

INTERNAL	Copies	INTERNAL	Copies
Weapons Instrumentation Division		Range Instrumentation Systems Department	
Code 1172		Code 3400	
A. Seter	1	J. C. Wilson	1
J. Tedder	1		
M. Wechsler	1	Data Collection Division	
Code 1173		Code 3410	
J. E. Scheid	1	J. R. Scott	1
Code 1174		Code 3411	
J. D. Martin	1	J. Bryant	1
G. J. Harbold	1	B. Casserly	1
D. H. Cronin	1	A. E. Gillaspy	1
		W. L. Blayney	1
Fleet Weapons Engineering Directorate		A. E. Hopwood	1
Code 2002		C. L. Monroe	1
G. R. Wachold	1	R. H. Wymore	1
		W. T. Norton	1
Range Directorate		Data Control Division	
Code 3001		Code 3440	
CAPT H. M. J. Lewis, Jr.	1	W. F. Tolman	1
Code 3002			
W. L. Miller	1	Data Processing Division	
Capabilities Development Department		Code 3450	
Code 3100		L. A. Hynds	1
J. F. Donlan	1	Code 3455	
		F. W. Greenway	1
Development Integration Division		R. A. Wallston	1
Code 3120			
H. J. Crawford	1	Engineering Applications Directorate	
Measurement Systems Development Division		Code 4001	
Code 3140		R. S. Walker	1
T. R. Carr	1	Technical Information Division	
Code 3141		Code 4230-1	
R. W. Lytle	1	M. Hayes	10
Code 3142			
G. E. Deakins	1	Library Systems Office	
C. G. Ashley	1	Code 6862	
J. Anderson	1	Technical Reports Library	2
R. A. Reed	1		
Code 3143		Patent Counsel	
M. A. Bondelid	1	Code PC	
Control Systems Development Division		Dr. J. M. St. Amand	1
Code 3151			
J. L. Weblemoe	1		
Code 3154			
P. M. Newton	1		

D
80

