

AD-A078 975

BRADDOCK DUNN AND MCDONALD INC EL PASO TEX
NET-2 NETWORK ANALYSIS PROGRAM, RELEASE 9. USER'S MANUAL, (U)
SEP 73 A F MALMBERG

F/G 9/5

DAAG39-70-C-0050

UNCLASSIFIED

HDL-050-1

NL

1 OF 3
AD
A078975



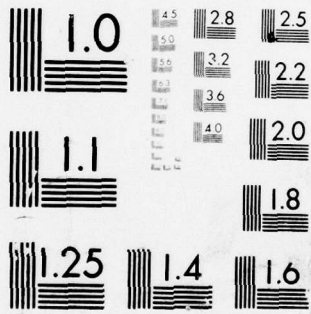

MICROCOPY RESOLUTION TEST CHART
NATIONAL BUREAU OF STANDARDS-1963-A

H74-0010

AD A 078975

cy 2

12 APR 1974

DDC FILE COPY

①

PROPERTY OF
U. S. ARMY
United States Army Materiel
HARRY DIAMOND LABORATORIES

AD

LEVEL #

HDL-050-1

USER'S MANUAL

IET-2 NETWORK ANALYSIS PROGRAM

RELEASE 9

Prepared by:

Allan F. Malmberg

Braddock, Dunn and McDonald, Inc.

6500 Convair Road
El Paso, Texas 79925

addendum
A078-976

September 1973

DDC
RECEIVED
DEC 26 1979
A

Prepared for:

U.S. ARMY MATERIEL COMMAND

HARRY DIAMOND LABORATORIES

WASHINGTON, D.C. 20438

Under Contract No. DAAG39-70-C-0050

This work was sponsored by the Defense Nuclear Agency under Subtask TC022.

79-12 21 030

Approved for public release; distribution unlimited.

A078

The findings in this report are not to be construed as an official Department of the Army position, unless so designated by other authorized documents.

Destroy this report when it is no longer needed. Do not return it to the originator.

V.V.

DNA MIPR 73-531
AMCMS Code: 691000.22.10714

HDL PROJ: 213328

AD

752
650

18 HDL 19 050-1

USER'S MANUAL

6 NET-2 NETWORK ANALYSIS PROGRAM, RELEASE 9. Users Manual,

Prepared by:

10 Allan F. Malmberg
Bredbeck, Dunn and McDonald, Inc.
6500 Convair Road
El Paso, Texas 79925

11 September 1973

12 230

Prepared for:

U.S. ARMY MATERIEL COMMAND

HARRY DIAMOND LABORATORIES

WASHINGTON, D.C. 20438

15 Under Contract No. DAAG39-70-C-0050
MIPR-73-531

This work was sponsored by the Defense Nuclear Agency under Subtask TC022.

Approved for public release; distribution unlimited.

062 150

gm

ABSTRACT

NET-2 is a general purpose computer program which solves the nonlinear time domain response and linearized frequency domain response of arbitrary networks composed of electric circuit elements and system operational elements. NET-2 performs parameter variation studies, statistical studies, and network performance optimization. Models are included for gamma rate and neutron dose radiation effects. A topological network description is utilized using a free form user oriented input language.

Accession For	
NTIS GRA&I	<input checked="" type="checkbox"/>
DOC TAB	<input type="checkbox"/>
Unannounced	<input type="checkbox"/>
Justification	<input type="checkbox"/>
By _____	
Distribution/	
Availability Codes	
Dist.	Avail and/or special
A	

PREFACE

This report constitutes the User's Manual for the Release 9 version of the NET-2 Network Analysis Program. It supersedes the User's Manual for Release 8 which was published in September, 1972.

Release 9 differs significantly from Release 8. New features which have been added to the program are summarized below:

1. Several new system elements have been added. Computation using these elements is handled using nonlinear simultaneous methods. Both time and frequency domain solutions are available for networks containing these elements. The new system elements include square root, absolute value, sign function, maximum function, minimum function, natural logarithm, exponential function, exponentiation, inverse sine, inverse cosine, inverse tangent, hyperbolic tangent, Euclidean norm, root mean square function, modulo function, quantizer, time delay, sample and hold, hysteresis, Boolean functions of AND, OR, and Exclusive OR, RST flipflop, synchronous clock, digital differential analyzer accumulator, output file interface, and input file interface.
2. Several new circuit elements have been added. These include a nonlinear voltage controlled current source, transmission line model, core winding model, and magnetic core model.
3. A data reduction feature has been included to permit modeled device parameters to be extracted from measured or published data.
4. The usage of mathematical expressions has been greatly extended. Many restrictions on the construction of mathematical expressions, function definitions, and table references have been removed.
5. Several additional mathematical functions are now available for use in constructing mathematical functions. These include four-quadrant inverse tangent, maximum function, minimum function, modulo function, and sign function.
6. Additional global quantities have been made available to the user. These include the current value of the time step and the accumulated neutron dose. All global quantities may now be referenced by the user.

There have been several modifications to NET-2 which will require revision of input decks which were prepared for use with Release 8. Although the revision of decks may be a painful process, it is felt that the increased flexibility offered by Release 9 will be worth the effort expended over the long term. The differences between Release 8 and Release 9 which may require deck revision are listed below:

1. Numerical constants which contain an exponent must include the character E before the exponent portion (see 1.2.2.2).
2. The character * must be used to denote multiplication in mathematical expressions (see 1.2.2.4.1).
3. Arguments of mathematical functions must be enclosed by parentheses (see 1.2.2.4.3).
4. The Release 8 mathematical function ARCTAN has been changed to ATAN (see 1.2.2.4.3).
5. The Release 8 mathematical function LN has been changed to LOG (see 1.2.2.4.3).
6. Network elements which have multiple values specified must have commas inserted to separate the values.
7. User defined functions without arguments may not be used. The X variable notation should be used instead (see 1.2.2.5 and 1.2.2.6).
8. The INITIAL Entry has been discontinued. Initial conditions available through this entry in Release 8 have now been incorporated into the respective element formats.
9. The INT (time integral) element format has been modified to include the specification of initial value (see 3.10).
10. The mathematical formulation for the capacitor, radiation effects capacitor, inductor, and coefficient of coupling have been modified to include the effects of time varying capacitance and inductance values (see 2.3, 2.4, and 2.5).
11. The formats for the MAXSTEP Entry and the TERMINATE Entry have been modified to include the = character (see 1.3.2.1 and 1.3.3).
12. The format for the GAMMA, GAMDOT, and NEUT Entries have been modified to include the = character. In addition, the order for specifying the neutron rate and the initial accumulated neutron dose for the NEUT Entry has been interchanged. (See 1.3.4.1 and 1.3.4.2).

13. The prefix for the Zener diode has been changed from D to ZD (see 2.16).
14. The prefix for the MOSFET has been changed from T to MFET. The MOSFET substrate node now appears as an external terminal. The exponential form of the slope of the MOSFET drain-source curve in region B has been replaced with a quadratic form; this modification may require the parameters K1, K2, and K3 to be redetermined. (See 2.19).
15. The prefix for the JFET has been changed from T to JFET. The exponential form of the slope of the JFET drain-source curve in the saturation region has been replaced by a quadratic form; this modification may require the parameters S1, S2, and S3 to be redetermined. (See 2.20).
16. Release 9 provides default values for all device model parameters which are not specified by the user. Many of these default values are nonzero. All default values provided by Release 8 for device parameters were zero. (See Tables 2-1, 2-3, 2-5, 2-7, 2-9, 2-11, 2-13, and 2-14).
17. The internal structure of the device parameter library has been revised. It will be necessary to regenerate the device parameter library.
18. Since the stored model library contains subnetwork descriptions using the NET-2 input language, it may be necessary to revise certain stored models in that library because of modifications in the input language.
19. Specification of an AC small signal variable in a PRINT or PLOT statement will provide only the magnitude or phase of that variable as specified. In Release 8 both magnitude and phase were automatically provided upon specification of either one. (See 6.1.4.1, 6.1.4.2, and 7.2.2).

The author wishes to acknowledge the contributions of Dr. Larry D. Ray for his work in the areas of the device parameter data reduction, the magnetic core model, the transmission line model, and several of the system element models, and Bill Kirkwood for his programming assistance in many areas. The continued support of Robert E. McCoskey, H. J. Matthews, and Robert Puttcamp of the Harry Diamond Laboratories is gratefully acknowledged.

The contributions of the Naval Ordnance Laboratory and the Los Alamos Scientific Laboratory through independently funded development efforts are acknowledged. The results of some of this independent work have been included in Release 9.

TABLE OF CONTENTS

	<u>Page</u>
ABSTRACT	iii
PREFACE	v
1. GENERAL	1
1.1 Introduction	1
1.1.1 Language Structure	1
1.2 Network Description	1
1.2.1 Element Specification	2
1.2.1.1 Circuit Elements	2
1.2.1.2 Modeled Devices	2
1.2.1.3 Linvill Elements	3
1.2.1.4 System Elements	4
1.2.2 Value Specification	4
1.2.2.1 Units	4
1.2.2.2 Numerical Constants	5
1.2.2.3 Symbolic Constants	5
1.2.2.4 Mathematical Expressions	6
1.2.2.4.1 Arithmetic Operations	6
1.2.2.4.2 Parentheses	7
1.2.2.4.3 Mathematical Functions	8
1.2.2.4.4 Tables	8
1.2.2.4.4.1 One-Dimensional Tables	9
1.2.2.4.4.2 Two-dimensional Tables	10
1.2.2.5 X Variables	12
1.2.2.6 Functions	13
1.2.2.7 Computational Delay	13
1.2.3 Modification of Values	14
1.2.3.1 PARAMETER Entry	15
1.2.4 Parallel Segments	15
1.3 Time Domain Response	16
1.3.1 Time Variable	16
1.3.2 Time Step Control	17
1.3.2.1 MAXSTEP Entry	18
1.3.2.2 Time Step References	18
1.3.3 TERMINATE Entry	18
1.3.4 Nuclear Radiation Effects	19
1.3.4.1 Gamma Radiation Source	19
1.3.4.2 Neutron Radiation Source	20
1.3.5 Time Domain Response Variables	21
1.4 Frequency Domain Response	21
1.4.1 Frequency Specification	21
1.4.2 AC Small Signal Variables	21

	<u>Page</u>
1.4.2.1 AC Small Signal Voltage Gain	22
1.4.2.2 AC Small Signal Current Gain	23
1.4.2.3 AC Small Signal Impedance	23
1.4.2.4 AC Small Signal Admittance	24
2. ELECTRICAL CIRCUIT ELEMENTS	25
2.1 Resistor	26
2.2 Voltage Controlled Conductance	27
2.3 Capacitor	28
2.4 Radiation Effects Capacitor	29
2.5 Inductor	30
2.6 Coefficient of Coupling	31
2.7 Switch	32
2.8 Voltage Source	33
2.9 Voltage Controlled Voltage Source	34
2.10 Current Source	35
2.11 Voltage Controlled Current Source	36
2.12 Nonlinear Voltage Controlled Current Source	37
2.13 Primary Photocurrent Generator	38
2.14 Transmission Line	41
2.15 Junction Diode	42
2.15.1 Equivalent Circuit	42
2.15.2 Junction Diode References	44
2.15.3 Junction Diode Data Reduction	46
2.16 Zener Diode	47
2.16.1 Equivalent Circuit	47
2.16.2 Zener Diode References	49
2.16.3 Zener Diode Data Reduction	51
2.17 Tunnel Diode	52
2.17.1 Equivalent Circuit	52
2.17.2 Tunnel Diode References	54
2.17.3 Tunnel Diode Data Reduction	56
2.18 Bipolar Transistor	57
2.18.1 Equivalent Circuit	58
2.18.2 Bipolar Transistor References	62
2.18.3 Bipolar Transistor Data Reduction	65
2.19 MOS Field Effect Transistor	68
2.19.1 Equivalent Circuit	68
2.19.2 MOSFET References	72
2.19.3 MOSFET Data Reduction	75
2.20 Junction Field Effect Transistor	76
2.20.1 Equivalent Circuit	76
2.20.2 JFET Parameter Symbols	81
2.20.3 JFET Data Reduction	84
2.21 Core Winding	86
2.22 Magnetic Core	88

	<u>Page</u>
2.22.1 Elastic ϕ Components	89
2.22.2 Inelastic ϕ Components	90
2.22.3 Static $\phi(F)$ Curve Model	90
2.22.3.1 General $\phi(F)$ Curve	91
2.22.3.2 Simplified $\phi(F)$ Curves	94
2.22.4 $\phi_p(F)$ Curve Model	95
2.22.5 Magnetic Core Parameter Data	98
2.22.5.1 $\phi(F)$ Curve Parameter Data	98
2.22.5.2 $\phi_p(F)$ Curve Parameter Data	99
2.22.6 Magnetic Core References	100
2.23 Combinance	103
2.24 Storance	104
2.25 Diffusance	105
2.26 Driftance	106
2.27 Linvill pn Junction	107
2.27.1 Linvill pn Junction References	108
2.28 Current Controlled Nodal Variable	110
 3. SYSTEM ELEMENTS	 111
3.1 SUM Element	111
3.2 GAIN Element	112
3.3 MULT Element	112
3.4 SQRT Element	113
3.5 ABS Element	113
3.6 SIGN Element	113
3.7 MAX Element	114
3.8 MIN Element	114
3.9 TABF Element	114
3.10 INT Element	115
3.11 DERIV Element	115
3.12 Transfer Functions in the s-plane	116
3.13 LOG Element	117
3.14 EXP Element	117
3.15 EXPN Element	117
3.16 SINCOS Element	118
3.17 ASIN Element	118
3.18 ACOS Element	118
3.19 ATAN Element	119
3.20 TANH Element	119
3.21 LIM Element	119
3.22 LIMINT Element	120
3.23 RNGEN Element	121
3.24 NORM Element	121
3.25 MOD Element	122
3.26 QUANT Element	122

	<u>Page</u>
3.27 DELAY Element	123
3.28 SAMPL Element	123
3.29 HYST Element	124
3.30 AND Element	125
3.31 ØR Element	126
3.32 EØR Element	127
3.33 RSTFF Element	128
3.34 ØUTFL Element	130
3.35 INPFL Element	131
3.36 SNCLK Element	132
3.37 DDACC Element	132
3.38 RMS Element	134
4. DEFINED SUBNETWORKS	135
4.1 DEFINE Entry	135
4.2 Referencing Nodes In The Nest	137
4.3 Referencing Network Parameters	140
4.4 Function and Table Definitions and References	141
5. STORED MODELS	143
5.1 Definition of Models	143
5.1.1 Restrictions on Function Definitions	145
5.2 Using Stored Models	146
6. STATE SOLUTION	147
6.1 STATE Entry	147
6.1.1 Network Parameter Value Changes	147
6.1.1.1 Constant Values	148
6.1.1.2 Varying Values	148
6.1.1.3 Topology Changes	149
6.1.2 Specification of DC Steady State and Transient Calculation	149
6.1.3 Device Modes	150
6.1.4 Output Statements	150
6.1.4.1 Print Statement	150
6.1.4.2 Plot Statement	151
6.1.5 Special Requirements for Output in Transient Calculations	152
6.1.5.1 Examples of Legal Forms for Transient Calculations	155
7. MONTE CARLO SOLUTION	159
7.1 Distribution Entry	160
7.2 MONTECARLO Entry	161
7.2.1 Parameter Values	161
7.2.2 Output Statements	162
7.2.3 Time Point of Sampling	162
7.2.4 Number of Monte Carlo Cases	162

	<u>Page</u>
8. OPTIMIZATION SOLUTION	163
8.1 OPTIMIZE Entry	163
8.1.1 Network Parameter Ranges	163
8.1.2 Network Parameter Constraints	164
8.1.3 Operational States	164
8.1.3.1 Objective Function Statements	165
8.2 CURVE Entry	167
8.3 Optimization Results	167
9. DEVICE PARAMETER AND STORED MODEL LIBRARY MAINTENANCE	169
9.1 LIBRARY Entry	169
9.1.1 Device Parameter Library Print	169
9.1.2 Device Parameter Library Modification	170
9.1.2.1 Device Parameter Data Reduction	171
9.1.3 Deletion of Devices	174
9.1.4 Copy Device Parameter Library	174
9.1.5 Stored Model Library Print	175
9.1.6 Deletion of Stored Models	176
9.1.7 Copy Stored Model Library	176
10. INPUT PREPARATION	177
10.1 Order of Entries	177
10.2 Representation of Indentation Levels	177
10.3 Card Continuation	177
10.4 Comment Cards	178
10.5 Punching of Entries	178
10.6 Time Limit Specification and Checkpoint/Restart Option	178
10.7 END Card	179
10.8 Multiple Runs	179
11. EXAMPLE PROBLEMS	181
REFERENCES	191
APPENDIX A: FORTRAN LOGICAL UNIT ASSIGNMENTS	193
APPENDIX B: SPECIAL WORDS AND PREFIXES IN NET-2	194

1. GENERAL

1.1 Introduction

The NET-2 Network Analysis Program is a general purpose digital computer program which solves the nonlinear time domain response and the linearized small signal frequency domain response of an arbitrary network described to the program.

NET-2 is capable of handling a variety of network components and can be applied to problems arising in several engineering fields, including electronics, control systems, heat flow, mechanical structures and systems, systems of nonlinear equations, and digital logic. The network elements may be freely intermixed permitting interdisciplinary problems to be solved.

NET-2 is able to perform parameter variation studies, statistical studies, and network performance optimization. The program has nuclear radiation effects modeling capability for studying the effects of gamma radiation and neutrons on circuit and system response.

1.1.1 Language Structure

The NET-2 language is organized into a series of entries, with each entry composed of one or more lines. The various lines are written at specified indentation levels, so that the complete input has the appearance of an outline form. The term indentation level is used throughout this report to indicate the relative positions of the various lines to the left margin when writing the input on paper. The left margin is always indentation level 0. Lines with indentation levels greater than zero are indented to the right of the left margin, with the amount of indentation proportional to the indentation level specified, e.g., a line at indentation level 2 is displaced further to the right than a line at indentation level 1. The first line of any entry always starts at indentation level 0, and subsequent lines of the entry, if any, begin at indentation level 1 or greater.

1.2 Network Description

A network consists of a set of elements interconnected through a set of network nodes. The network can be described by individually describing each element and how it is connected to the network node system.

The description of each network element requires specification of the element type, the names of the nodes to which it is connected, and the values to be attached to the parameters which control the element behavior. Values may be described either numerically or symbolically in terms of other quantities unless otherwise noted.

Every network element is assigned a name or ID which consists of a prefix and a suffix. The prefix is composed of alphabetic characters only and denotes the element type. The suffix must always begin with a numeric character, followed by any combination of alphabetic and numeric characters. The suffix is always denoted by the small letter n immediately following the prefix in this report. Each network element should be assigned a unique name to prevent confusion when references are made to the elements. Examples of acceptable element names are R378 and TLINE7AB for a resistor and a transmission line, respectively.

The network nodes are assigned arbitrary names. Any combination of alphabetic and numeric characters may be used. All node voltages are measured with respect to a datum or ground node. The datum node is designated by the integer 0. It is recommended that all networks include a datum node. A network may exist in several isolated parts; NET-2 will automatically choose one of the nodes in each isolated part as the datum node unless node 0 is already included in that isolated part.

1.2.1 Element Specification

NET-2 accommodates a large variety of network elements of different types. The following sections discuss the general classes of elements available in the program. Chapters 2 and 3 give specific details for circuit and system elements, respectively.

1.2.1.1 Circuit Elements

NET-2 contains a set of circuit elements from which electrical and electronic circuits can be constructed. When these elements are interconnected voltages may appear at the element terminal nodes and currents may flow through the element terminals. The nodes to which such elements are connected are called circuit nodes, and the nodal quantities associated with the nodes are the node voltages.

1.2.1.2 Modeled Devices

NET-2 contains a subset of circuit elements which are called modeled devices. They include the semiconductor devices and the magnetic core. They are distinguished by complex nonlinear models and usually require many numerical parameters to control their behavior.

Each modeled device has a model number associated with it. By means of the model number, a specific equivalent circuit and a set of controlling equations are entered into the network calculation to represent that modeled device.

The user must also specify a type name for the modeled device. The type name is limited to a maximum of eight alphanumeric characters. The type name enables NET-2 to locate and retrieve a set of numerical values for the device parameters from the Device Parameter Library. These values are then used by the device model equations to represent a particular device in the calculation. The device parameters must always be represented as numerical constants. The user may reference and modify any device parameter value during the calculation. NET-2 supplies default values for all device parameter values which are not specified by the user.

Radiation effects behavior is included for many of the modeled devices. The inclusion of radiation effects requires many additional parameters and additional computation. However, NET-2 is written in such a way that the additional parameters and calculations are required only if a neutron or gamma radiation source is specified in the input. Thus, the user with no interest in radiation effects behavior is not penalized in speed and network size capability.

Certain devices permit the user to specify optional mode information to assist NET-2 in obtaining the desired network solution. The mode information specifies which operational mode the device is to assume in situations where the network response is multistable in the DC steady state solution.

1.2.1.3 Linvill Elements

NET-2 contains special circuit elements to represent the Linvill elements of capacitance, inductance, diffusive, drift, and the pn junction. Radiation effects are not specifically included but can be added through the general nonlinear capabilities of NET-2.

The availability of these elements as individual building blocks permits one to construct Linvill models of any complexity by suitably interconnecting these elements. With such an approach entire microcircuits can be constructed and studied with NET-2.

A special kind of node is utilized in connection with Linvill elements. It is called a carrier node and is used to represent excess carrier density (as opposed to the circuit node which represents node voltage). Current may flow into and out of carrier nodes in much the same way as for circuit nodes. However, the only components which may be connected to carrier nodes are current sources, primary photocurrent sources, and the carrier node terminals of Linvill elements.

A carrier node may represent either electron or hole excess density, as distinguished by the sign of the excess carrier density associated with the node. Excess carrier density at a carrier node is analogous to voltage at a circuit node; thus, the notation $N(x)$ will always refer to the excess carrier density at carrier node x . $N(x)$ is positive for holes and negative for electrons.

1.2.1.4 System Elements

NET-2 includes a set of network elements which are called system elements. These elements perform operational functions on variables which appear on their input nodes, delivering the result as a nodal variable at the output node. The output node of a system element is called a system node.

A system element may be viewed as a specialized electrical element. The input nodes of a system element have infinite input impedance, i.e., the system element does not extract any energy from the network. The voltages on the input nodes are transformed by the system element with the result appearing on the system element output node as a node voltage. The system element output is always referred to node 0 and has zero output impedance, i.e., it is capable of delivering an infinite amount of energy to the network.

The user must never connect two system element outputs to the same node since it is not physically possible to obtain a solution which satisfies both system elements simultaneously except under special conditions. Also, since the input nodes have infinite input impedance, the user must always insure that an impedance path exists from every system element input node to network ground to avoid solution of a singular system of equations. This impedance path is always present if a system element input is connected to a system node.

The nodal variable at a system node x is referenced by using the symbolic name $N(x)$.

1.2.2 Value Specification

The network element descriptions and other elements of the NET-2 descriptive language require the user to specify values for purposes of calculation. These values may be specified either as numerical constants or in symbolic form using mathematical expressions and/or symbolic constants.

1.2.2.1 Units

Any self-consistent set of units may be used with the NET-2 program. Care must be taken when using modeled devices and stored models in a circuit since these circuit elements already have numerical values attached to them as they exist in their respective libraries. Since these numerical values presuppose a particular set of units, the user must be careful to employ the same set of units in his own circuit description.

It is wise to use a set of units such that the magnitudes involved tend to center about unity. The range of magnitudes should be confined between 10^{-10} and 10^{10} if possible.

A set of units which works well for electronic circuit calculations is the following:

Voltage	volts
Current	milliamperes
Charge	picocoulombs
Flux	nanowebers
Energy	picojoules
Power	milliwatts
Resistance	kilohms
Capacitance	picofarads
Inductance	microhenries
Time	nanoseconds
Frequency	gigahertz
Impedance	kilohms
Admittance	millimhos

1.2.2.2 Numerical Constants

Numerical constants are composed of a string of digits, optional sign and decimal point, and an optional exponent. The plus sign is optional for positive constants. The decimal point is not required if it occurs to the right of the last magnitude digit. The exponent, if used, must always follow immediately after the magnitude and begin with the letter E. The exponent value is expressed as a signed integer, representing a power of ten, with the plus sign optional for positive exponents.

Examples of legal numerical constants are:

25
+2.34
-35.78
4.E+6
9.789E-3
65E7

1.2.2.3 Symbolic Constants

The user may define constants in symbolic form. The format is:

Pn Value

where Pn = symbolic name
Value = numerical value of constant

A symbolic constant may be referenced by using its symbolic name. The value of the constant may be altered in any of the NET-2 operational modes, such as in a State solution.

The symbolic constant is normally defined at indentation level 0 (exceptions may occur in defined subnetworks and stored models).

1.2.2.4 Mathematical Expressions

Mathematical expressions have many uses in NET-2. They may be used for element values, function definitions, and objective function statements.

Quantities used in constructing the expression include numerical constants, symbolic constants, function references, table references, response variables, global variables, X variables, and element values and parameters. When the mathematical expression is used in the definition of functions containing dummy arguments, the expression may also contain the names of the dummy arguments. Also available are a variety of mathematical symbols and several mathematical functions.

The expression is written using constructions similar to those used in FORTRAN.

1.2.2.4.1 Arithmetic Operations

The arithmetic symbols +, -, *, /, and **, are used to denote addition, subtraction or negativity, multiplication, division, and exponentiation, respectively.

All arithmetic operators must explicitly appear in mathematical expressions. No operations are assumed by juxtaposition of quantities.

In division, only the quantity immediately following the division sign is considered to be in the denominator. Compound denominators must be enclosed in parentheses. These examples illustrate the point:

$X6 = R1/.5*R3$ is interpreted as $X6 = \frac{R1 R3}{.5}$

$X7 = R1/(.5*R3)$ is interpreted as $X7 = \frac{R1}{.5R3}$

The minus sign may be used to indicate the negative of a quantity:

$X9 = -N(1)$

Exponentiation is indicated by the symbol **, where the quantity appearing immediately after the symbol is the exponent. Exponents may be constant or variable. Compound exponents must be enclosed in parentheses. Exponents consisting only of integer constants should be written without the decimal point. Examples are:

V(R6)**2
 I(C1)**N(45)
 R6**(C1/C2)
 2**R9

An expression such as A**B**C is ambiguous and parentheses must be used to indicate the proper grouping.

1.2.2.4.2 Parentheses

Left and right parentheses are available for grouping purposes. As many levels of parentheses may be employed as necessary. It is important to check for proper pairing of left and right parentheses so that ambiguous or incorrect groupings are avoided. Examples of correct usage are:

$$X1 = R1/(R2*(N(1) + R3))$$

which represents the expression

$$X1 = \frac{R1}{R2(N(1) + R3)}$$

A more complicated example is

$$X2 = .0026*((N(1)+12/(I(R3)+R2))/(R3+T3.BN/((N(GT6.FY7.T5.4)+3.5)*R7)))$$

which represents the expression

$$X2 = .0026 \frac{. N(1) + \frac{12}{I(R3) + R2}}{R3 + \frac{T3.BN}{(N(GT6.FY7.T5.4) + 3.5) R7}}$$

1.2.2.4.3 Mathematical Functions

The following mathematical functions are available for use in mathematical expressions:

ABS(x)	Absolute value of x
ATAN(x)	Inverse tangent of x, result in radians
ATAN2(x,y)	Inverse tangent of x/y, result in radians
COS(x)	Cosine of x, x in radians
EXP(x)	Exponential function of x
LOG(x)	Natural logarithm of x
MAX(x,y)	Maximum value of x and y
MIN(x,y)	Minimum value of x and y
MOD(x,m)	x modulo m
SIGN(x,y)	Magnitude of x with sign of y
SIN(x)	Sine of x, x in radians
SQRT(x)	Square root of x, x positive
TAN(x)	Tangent of x, x in radians
U(x)	Unit step function of x

The unit step function is defined as follows:

$$\begin{aligned}U(x) &= 0 & x < 0 \\U(x) &= 1/2 & x = 0 \\U(x) &= 1 & x > 0\end{aligned}$$

Function arguments must be enclosed in parentheses. Examples are:

```
U(N(56))
SQRT(R6/R7)
COS(-2)
SIN(-R6)
SIN(COS(R6))
```

1.2.2.4.4 Tables

Tables are used to describe arbitrary nonanalytic functional relations. Both one-dimensional and two-dimensional tables are available, having one and two arguments, respectively.

Definition of a table requires several lines. The first line generally occurs at indentation level 0 (exceptions will be noted in Chapter 5) and includes the table ID. Subsequent lines occur on the next indentation level, usually level 1, each line specifying numerical information.

Arguments which may be used in table references may be any mathematical expression. If the table reference is part of the definition of a function, the table arguments may include dummy arguments of the function being defined.

1.2.2.4.4.1 One-dimensional Tables

The one-dimensional table is referenced using a single argument and may represent an empirical relation which is either periodic or nonrepetitive. The first line consists of the table ID, written as TABLEn, where n is the suffix. Subsequent lines specify number pairs which define the empirical relation. The format is:

TABLEn

```
x1 y1
x2 y2
.
.
.
xm ym
```

where: x_k = the kth coordinate value corresponding to the table argument

y_k = the kth value of the table corresponding to x_k

Periodic or repetitive tables may be specified by inserting the letter R for the value of y_m . This indicates that the table is to be repeated indefinitely with a period $x_m - x_1$. Otherwise, the table will terminate and produce a value of y_m for all arguments greater than x_m .

Regardless of whether the table is repetitive or not, for values of argument less than x_1 , the table will furnish a value of y_1 .

References to one-dimensional tables occur at some other point in the NET input, for example, as circuit element values:

```
V7 5 9 TABLE8(TIME)
```

This indicates that the value of V7 is an arbitrary function of TIME, as given by TABLE8.

Values between the specified points are determined by straight line interpolation.

An example of a periodic table definition corresponding to the curve shown in Fig. 1-1 is:

```
TABLE43
2      3
2.5    4
3      5
4      1.5
4.5    1
5      R
```

Note that the initial value of 3 is maintained for all values of independent variable less than 2, and that the table has a period of 3 for all values of independent variable greater than 2.

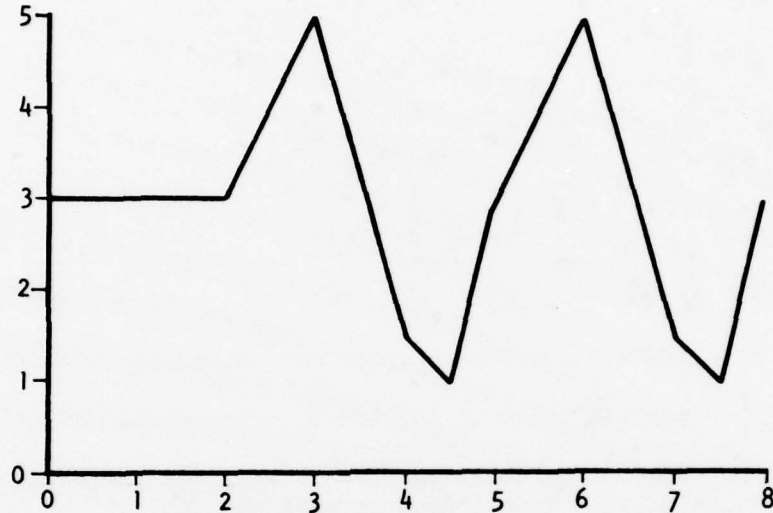

Figure 1-1. Curve for TABLE Entry Example

1.2.2.4.4.2 Two-dimensional Tables

The two-dimensional table is referenced using two arguments and may represent an empirical function of two variables which is nonperiodic. The first line of the table definition consists of the table ID, written as TABLEn, where n is the suffix, followed by an integer which specifies the number of values of the second argument which is to be used in defining the table. The second line is indented and contains the values of the second argument. Subsequent lines are also indented and specify the value of the first argument and values of the empirical function.

The format for two-dimensional table definition is:

TABLEn m

y_1	y_2	y_m
x_1	z_{11}	z_{12} z_{1m}
x_2	z_{21}	z_{22} z_{2m}
.	.	.	.
x_k	z_{k1}	z_{k2} z_{km}

where: TABLEn is the table ID
m is an integer specifying the number of columns in the array of table values (i.e., the number of values specified for the second argument)
 y_1, y_2, \dots, y_m are the numerical values of the second argument used to define the table values z
 x_1, x_2, \dots, x_k are the numerical values of the first argument used to define the table values z
 z_{ij} is the numerical table value corresponding to the specified values of x_i and y_j

Interpolation between specified table values is done linearly. The intervals between the successive x and y values used to define the table values do not need to be uniform.

A reference to a two-dimensional table can be thought of as evaluating the relation $z = F(x,y)$. The format for a reference is

TABLEn(x,y)

where: TABLEn is the ID of the desired two-dimensional table
x and y are the symbolic names of the arguments x and y, respectively

If the argument values used in the table lookup fall outside the defined range of the table, the table value at the closest point on the edge of the table will be used.

1.2.2.5 X Variables

The user may define variables by means of mathematical expressions. These variables may in turn be referenced in other mathematical expressions and used for output purposes. The variables are called X variables and are represented symbolically by Xn. For example, a definition of X45 might be

$$X45 = \text{SIN}(\text{SQRT}(\text{N}(\text{OUTPUT}))) + 3.5)$$

X45 can then be referenced in the same manner as any other variable in NET-2:

```
X32 = 5.7*X45/(TIME + 2)
STATE3
  PLOT X32 VS X45
```

The user may also define and reference the time derivatives of X variables. These are distinguished from X variables by the symbolic form X'n where Xn is the related X variable.

$$X'789 = 12*R1 + 3$$
$$X5 = X'789/2.5$$

NET-2 will automatically integrate all X' variables and differentiate all X variables. Thus, the corresponding X and X' quantities that have been automatically determined by NET-2 are available for reference. For example:

$$X45 = \text{SIN}(\text{SQRT}(\text{N}(\text{OUTPUT}))) + 3.5)$$
$$X'789 = 12*R1 + 3$$
$$X3 = X'45/X789$$

The user is not permitted to define both a particular X variable and its corresponding time derivative.

There are restrictions on the usage of X and X' variables. These are:

- a. They may not be involved in simultaneous relationships.
- b. They are not available for frequency domain calculations.

1.2.2.6 Functions

There are certain mathematical relationships whose form is used over and over again. These relationships may be expressed as functions.

A function definition consists of the function name, a set of dummy arguments, and a defining mathematical expression. The mathematical expression is written in terms of the dummy arguments and may include other quantities as well.

The names for the dummy arguments may be of any length and composed at will from the alphanumeric characters, provided there is not any conflict between the name chosen and sequences of characters which have other meanings to NET-2. The dummy argument name must begin with an alphabetic character.

Examples of legal names for dummy arguments are A1, AFG, AFG23, A2B, A2B56, etc.

A function definition is generally written on indentation level 0 (exceptions will be noted in later chapters). It begins with the function name (always of the form Fn), immediately followed by an ordered set of dummy arguments enclosed in parentheses. The dummy arguments are separated by commas. Next comes an equal sign, followed by the defining mathematical expression. For example:

$$F56(A,B,C) = A * C / S(P1) + B / TIME + C$$

At some other point in the NET-2 input there occurs a function reference which is of the same form as the left side of the function definition equation, except that the dummy arguments may be replaced by known quantities, including numerical constants and mathematical expressions.

An example of a reference to the function F56 defined above is:

```
C23 6 9 F56(3,N(3),F2(TABLE2(X13/I(C5))))
```

Arguments in a function reference may be written as any mathematical expression. If the function reference is part of the definition of another function, the arguments of the referenced function may include dummy arguments of the function being defined.

1.2.2.7 Computational Delay

NET is not yet capable of handling all user specified mathematical relationships in truly simultaneous fashion. Whenever simultaneity cannot be observed a warning message will be printed to inform the user that computational delay may be present in the computed results.

Computational delay occurs when previous values of a computed quantity are used to evaluate a mathematical expression instead of current values. NET will perform simultaneous computations whenever possible in which case computational delay will not occur.

The user may request NET to abort a run in the event computational delay occurs. This is done by including the card:

```
DEBUG 43
```

An example of a situation in which computational delay presently occurs is:

```
R6 5 9 SQRT(V(C7))
```

In this example the value of R6 depends upon the voltage across C7. However, the voltage across C7 depends upon the network solution and thus upon the value of R6. A computational delay will be introduced such that R6 will be evaluated first, using the voltage across C7 at the previous time point. Then the network solution will be calculated using this value for R6. This leads to a new value of the voltage across C7 which may not simultaneously satisfy the R6 relationship. Thus a computational delay has been introduced due to the nonsimultaneity of the solution.

The validity of frequency domain calculations cannot be guaranteed for networks which have computational delay.

1.2.3 Modification of Values

Initially, all element values are determined by the values associated with the network element descriptions and by the device parameter values read from the Device Parameter Library. Any of these initial values which have been defined as numerical constants may be permanently altered before any calculation begins by means of the PARAMETER Entry which reads in new values for specific elements and device parameters. The final values in use after modification by the PARAMETER Entry are called the nominal values, and all calculations proceed from these nominal values unless subsequently altered by the Optimization calculation.

In the network description, all parameter values are prescribed as either numerical constants or some symbolic expression. They must remain in this prescribed form throughout the calculation, i.e., numerical constants cannot be swapped for symbolic expressions and vice versa. In this connection, note that all device parameters are entered as numerical constants from the device library. They must remain as numerical constants (although there is no restriction on changing their values).

1.2.3.1 PARAMETER Entry

Any network parameter value which has been defined by a numerical constant may be changed in the PARAMETER Entry. The ID for the parameter is listed followed by the new value. The new value may be given either as an actual value or as a relative value. Relative values are suffixed with an asterisk; the actual value is then the product of the initial value and the relative value.

The nominal values for network parameters not listed in the PARAMETER Entry are the same as the initial values.

Device modes can be changed by using the word MØDE as a device parameter name. A previously assigned mode can be removed by using the word NØNE.

An example of a PARAMETER Entry is:

```
PARAMETER
  R12 390
  C13 .85*
  T2.BN 150
  T3.MØDE ØFF
  T5.MØDE NØNE
```

The PARAMETER Entry is always constructed with two or more lines. The first line contains only the word PARAMETER and always starts at indentation level 0. Subsequent lines list the ID and nominal value information and always start at indentation level 1.

1.2.4 Parallel Segments

Parallel segments exist whenever a network contains several identical segments, and these segments have all connection points into the rest of the network in common (i.e., the segments are in parallel with each other). NET-2 element description formats have special provisions for describing such parallel segments. This feature should be used whenever possible in order to minimize computing time.

In describing parallel segments to NET, node names and ID's are assigned within only one of the segments. The element descriptions for that segment are then tagged with a number in parentheses to indicate how many parallel segments are represented.

The values specified for the elements and device parameters in parallel segments are for a single element only. Similarly, all response variables

associated with a given element represent a single element only. NET internally scales the numbers to account for the parallel nature of the network during the calculation.

The parallel segment designation when used is always placed immediately following the ID. Examples are:

```
L2 (4) 5 8 .45
R3 (6) 6 2 39
C7 (2) 5 9 15.5
T3 (3) 2 7 5 2N1509
D7 (2) 4 8 IN784
I34 (7) 2 7 .75
```

The use of parallel segment designation with certain elements is meaningless. The inadvertent use of the parallel segment designation in a meaningless situation does not cause any harm, however.

1.3 Time Domain Response

NET-2 has the capability of calculating the nonlinear time domain response of any arbitrary network configuration which can be described to the program. The time domain response includes both the DC steady state solution and the transient solution. The steady state solution is always calculated first, and serves as the initial conditions for the transient solution.

The time domain response is controlled by user specification of the time variable. This is accomplished in several alternative ways to provide flexibility for the user. In addition, NET-2 may exert internal control on the time variable in nonlinear network calculations for purposes of maintaining solution accuracy.

1.3.1 Time Variable

The independent variable in the time domain calculation is time. This quantity may be specified by the user for purposes of indicating the time at which certain action is to be taken, such as delivering output or evaluating objective functions in an OPTIMIZE solution. The time variable is always specified symbolically by TIME and any value assigned to it by the user must always be expressed as a numerical constant. The user may refer to the current value of TIME at any point in a calculation.

TIME has a value of zero during the DC steady state calculation.

1.3.2 Time Step Control

NET calculates the transient solution by using a trapezoidal implicit integration method which involves advancing the solution from one time point to the next through a series of time steps. The size of these time steps generally affects the accuracy of the transient solution.

A general rule of thumb is that the time step size must be small enough so that any response which is changing in the network is followed adequately. This implies that if the response is changing very slowly or not changing at all a large time step may be used. Since the integration method in the program is stable such a large time step is useable under these conditions.

In estimating time step size let us imagine the solution as being available at only discrete points in time, these points corresponding to the end of each time step. Let the solution points be connected by straight line segments. If this representation adequately describes the solution, then the time step size is probably of the right magnitude.

Two points should be kept in mind when applying the preceding rule. First, there will be some integration error introduced (generally evident as a time lag) and this error may cause appreciable inaccuracies in the solution as a function of time for large values of time (i.e., the time lag errors can become cumulative). Secondly, all variables involved in the solution (i.e., all node voltages and element currents) must be considered in making the time step estimate, not just those quantities which are to be delivered as output.

The user is required to impose some form of time step control whenever a transient solution is requested. This may be done by specifying a maximum time step constraint (MAXSTEP Entry), by specifying particular values of TIME, or both.

The MAXSTEP Entry specifies an upper bound for the time step size during the transient solution. This entry is mandatory if there is no nonzero value of TIME specified and a transient solution is required. If nonzero TIME values are specified, the entry is optional.

The user may specify nonzero values of time using TIME as a swept variable in a State or Optimization solution. This type of specification informs NET of the points in time where output is required; the program must obviously take time steps no larger than the interval between two successive time point requests. However, since this interval may be too large for desired computational accuracy, the MAXSTEP Entry may be employed in conjunction with the TIME swept variable specification to control the maximum time step size. In any event, if both MAXSTEP and TIME swept variable control are present, NET will use the smaller of the time steps imposed by each as the actual time step at a given point in the transient solution.

If the network contains nonlinear elements, NET may employ a time step smaller than that imposed by the user to insure convergence of the nonlinear network element response. NET contains provisions for halving the time step whenever satisfactory convergence of nonlinear elements cannot be achieved in ten iterations. If the time step is halved twenty times in succession without achieving convergence, the run is aborted with an error message. On the other hand, if convergence is obtained in less than three iterations and the time step controls imposed by the user permit, NET will double the time step. This automatic halving and doubling of time step is controlled internally by NET and is subject to all time step constraints imposed by the user.

1.3.2.1 MAXSTEP Entry

It is possible to constrain the maximum time step size during the transient solution with the MAXSTEP Entry. The format is:

MAXSTEP = Value

where Value may be a numerical constant or any mathematical expression. If the MAXSTEP Entry is not specified but the circuit contains nonlinear elements the program will automatically employ a maximum time step consistent with internal convergence criteria.

There is only one MAXSTEP Entry permitted and it must appear at indentation level 0.

The user may reference the value of MAXSTEP by using the symbolic name MAXSTEP.

1.3.2.2 Time Step References

During the transient solution the time step in use may be referenced by the user through the symbolic name DELTAT. The DELTAT variable may be used in any mathematical expression. During the DC steady state solution DELTAT will have a value of unity.

1.3.3 TERMINATE Entry

The user always specifies the value of time at which termination of the transient solution occurs. This time value can be expressed either as a specific numerical value or it may be specified indirectly, i.e., termination occurs as soon as a prescribed condition occurs.

The TERMINATE Entry permits the user to specify the prescribed condition for termination. The format is:

TERMINATE = Value

where Value is any mathematical expression. Termination occurs as soon as the value of the mathematical expression becomes greater than zero. Note that termination can occur at zero time. If numerical values are specified for the time variable in a particular calculation, the word FINAL will be required to activate the TERMINATE feature (See 6.1.5).

There is only one TERMINATE Entry permitted and it must appear at indentation level 0.

The user can reference the value of the mathematical expression by using the symbolic name TERMINATE.

1.3.4 Nuclear Radiation Effects

NET-2 contains facilities for studying the effects of gamma and neutron radiation on network performance. The effects are calculated only when the NET-2 input contains either a gamma radiation source or a neutron radiation source.

In addition to specific radiation effects behavior which is included in many of the modeled devices, NET-2 contains a primary photocurrent generator circuit element which may be used both to augment existing radiation effects models and as a separate photocurrent generator for providing basic radiation effects behavior.

1.3.4.1 Gamma Radiation Source

The user may include a gamma radiation source in the NET-2 input for purposes of studying the effects of gamma radiation on network performance. The gamma radiation source provides either the gamma rate or the gamma dose as a function of time for all gamma radiation effects included in the modeled devices and for the primary photocurrent generator circuit element.

The format for specifying the gamma radiation source as a gamma rate is:

GAMDØT = Value

where Value = gamma rate as a function of time.

Alternatively, the user may wish to specify the gamma radiation source as a gamma dose. The format is:

GAMMA = Value

where Value = gamma dose as a function of time.

The user may specify either the GAMDØT Entry or the GAMMA Entry but not both. NET-2 will automatically integrate the gamma rate or differentiate the gamma dose so that both rate and dose information are available internally to the program.

The GAMDØT Entry may specify a nonzero gamma rate at time zero to permit DC steady state gamma rate effects to be calculated; in such event the time zero gamma dose is assumed to be zero. Similarly, the GAMMA Entry may specify a nonzero gamma dose at time zero to permit DC steady state gamma dose effects to be calculated; in such event the time zero gamma rate is assumed to be zero.

Only one gamma radiation source may be specified and it must occur at indentation level 0.

The user may reference both the gamma radiation source values by using the symbolic names GAMMA and GAMDØT.

1.3.4.2 Neutron Radiation Source

The user may include a neutron radiation source in the NET-2 input for purposes of studying the effects of neutron radiation on network performance. The neutron radiation source provides the neutron rate as a function of time for all neutron radiation effects included in the modeled devices. Provisions are also included for specifying initial accumulated neutron dose to permit automatic degradation of modeled device parameters due to previous neutron damage. The DC steady state solution includes all effects due to initial accumulated neutron dose.

The format for the neutron radiation source is:

NEUT = Value, ϕ_0

where: ϕ_0 = initial accumulated neutron dose at TIME = 0

Value = neutron rate as a function of time

The total neutron dose or fluence at time t is automatically calculated. by NET-2 as

$$\phi(t) = \phi_0 + \int_0^t \phi(\lambda) d\lambda$$

where $\phi(\lambda)$ is the instantaneous value of the NEUT Entry at time λ .

The NEUT Entry is written at indentation level 0. There may be only one NEUT Entry specified.

The user may reference the neutron rate and the neutron dose by using the symbolic names NRATE and NDØSE, respectively.

1.3.5 Time Domain Response Variables

The user may reference the voltage at any node in the network with respect to the global network ground node, including nodes inside of modeled devices, by using the symbolic notation $N(x)$ where x is the node name.

The user may reference the value of any quantity in the value field of a network element using the notation specified in the description for that element in this report. Many elements also have response variables which may be referenced using notation described elsewhere in this report for specific elements.

1.4 Frequency Domain Response

NET-2 has the capability of calculating the small signal linearized frequency domain response of any network which is described to it, provided that the network does not contain computational delays. The frequency domain response may be calculated at one or more values of frequency, including zero frequency.

The frequency domain response is always evaluated at one or more points in time, using the nonlinear time domain solution as a basis for establishing the linearized equivalent network for the frequency domain. In the absence of a time value specification, NET-2 will assume the DC steady state network condition as a basis.

1.4.1 Frequency Specification

The value of frequency to be used in the AC small signal calculation is specified by the FREQ variable. The format is:

FREQ Value

where Value is always a numerical constant. If FREQ is not specified a default value of zero will be used.

The FREQ entry occurs at indentation level 0 and is in effect except as modified in a particular State, Monte Carlo, or Optimization solution.

1.4.2 AC Small Signal Variables

The AC small signal variables include voltage and current gain, transfer and self-impedance, and transfer and self-admittance. They are calculated as complex quantities, consisting of a magnitude and phase, at the frequency specified by FREQ. If the circuit is nonlinear, the circuit operating point is determined first, then the small signal values of the circuit elements are evaluated at that operating point for use in the AC small signal calculations. These quantities may be evaluated at zero frequency if desired.

The AC small signal variables are defined through the use of input and output ports, where each port consists of a pair of nodes. One node of each pair is designated as a reference node. Let the output port be defined by nodes p and q (q is the reference node) and let the input port be defined by nodes r and s (s is the reference node). NET-2 then determines the desired AC small signal variable by effectively connecting either a zero impedance voltage source or a zero admittance current source across the input port, and either a zero admittance voltmeter or a zero impedance ammeter across the output port. The response variable is then taken to be the ratio of the measured response to the exciting signal. The exciting signal is of infinitesimal amplitude and is a sinusoid at the specified frequency.

In reality, NET does not actually connect sources and meters into the circuit, but calculates the variables directly from the circuit impedance matrix. However, the results obtained are identical to applying the above measuring technique to the circuit.

Phase is represented in radians for all internal calculations and is printed or plotted in degrees.

The DC steady state and transient calculations must not depend in any way upon the AC small signal calculation.

1.4.2.1 AC Small Signal Voltage Gain

The AC small signal voltage gain is determined by effectively connecting a voltage source across the input port and a voltmeter across the output port. This operation causes the input port to be short circuited for the small signal only --- the operating point is not disturbed.

The notation for the magnitude of the voltage gain is:

$$A(p-q/r-s)$$

The notation for the phase angle of the voltage gain is:

$$A'(p-q/r-s)$$

where p, q, r, and s are the names of the nodes comprising the ports.

1.4.2.2 AC Small Signal Current Gain

The AC small signal current gain is determined by effectively connecting a current source across the input port and an ammeter across the output port. This operation causes the output port to be short circuited for the small signal only --- the operating point is not disturbed.

The notation for the magnitude of the current gain is:

$$B(p-q/r-s)$$

The notation for the phase angle of the current gain is:

$$B'(p-q/r-s)$$

where p, q, r, and s are the names of the nodes comprising the ports.

1.4.2.3 AC Small Signal Impedance

The AC small signal impedance is determined by effectively connecting a current source across the input port and a voltmeter across the output port.

If the input and output ports are different, the transfer impedance will result; if the ports are the same, the port self-impedance will result.

The notation for the magnitude of the impedance is:

$$Z(p-q/r-s)$$

The notation for the phase angle of the impedance is:

$$Z'(p-q/r-s)$$

where p, q, r, and s are the names of the nodes comprising the ports.

1.4.2.4 AC Small Signal Admittance

The AC small signal admittance is determined by effectively connecting a voltage source across the input port and an ammeter across the output port. This operation causes both the input and output ports to be short circuited for the small signal only --- the operating point is not disturbed.

If the input and output ports are different, the transfer admittance will result; if the ports are the same, the port self-admittance will result. It should be noted that in general the transfer admittance is not the same as the reciprocal of the transfer impedance.

The notation for the magnitude of the admittance is:

$$Y(p-q/r-s)$$

The notation for the phase angle of the admittance is:

$$Y'(p-q/r-s)$$

where p, q, r, and s are the names of the nodes comprising the ports.

2. ELECTRICAL CIRCUIT ELEMENTS

This chapter describes the electrical circuit elements available in NET-2. For each circuit element information is included on the element description format, the mathematical relationships which describe the behavior of the element, and the response variables associated with the element.

The parallel segment designation is shown in the element format whenever it is applicable to the element. The inadvertent use of parallel segment designation with an element to which it is not applicable does no harm. The parallel segment designation is always optional.

Value fields in the description format may be expressed as either numerical constants or mathematical expressions. Multiple values must always be separated by commas. The values of device parameters must always be expressed as numerical constants since they are stored in and retrieved from a Device Parameter Library which does not have the capability of handling mathematical expressions.

2.1 Resistor

The format for a resistor is:

Rn (p) a b Rvalue

where: Rn = element ID
p = optional parallel segment designation
a and b = node names
Rvalue = resistance value

The resistor must not assume a value of zero.

The resistor voltage v is given by

$$v = e_a - e_b$$

where e_a and e_b are the node voltages at nodes a and b, respectively.

The resistor current i is given by

$$i = v/R$$

where R is the resistance value.

The power dissipation P is given by

$$P = iv$$

The user may reference the resistance value, the resistor voltage, the resistor current, and the power dissipation by using the symbolic names R_n , $V(R_n)$, $I(R_n)$, and $P(R_n)$, respectively.

2.2 Voltage Controlled Conductance

A special element is available for describing a resistor whose conductance is proportional to the voltage across a node pair.

The format for the element is:

VCGn (p) f g a b K

where: VCGn = element ID

p = optional parallel segment designation

f and g = node pair node names

a and b = node names for element connection points

K = value of proportionality factor

The conductance is inserted into the network between nodes a and b. The conductance value G is given by

$$G = K(e_f - e_g)$$

where e_f and e_g are the node voltages at nodes f and g, respectively.

The voltage v across the conductance is given by

$$v = e_a - e_b$$

where e_a and e_b are the node voltages at nodes a and b, respectively.

The current i flowing through the conductance is given by

$$i = Gv$$

The power dissipation P of the conductance is given by

$$P = iv$$

The user may reference the proportionality factor K, the voltage across the conductance, the current through the conductance, and the power dissipation in the conductance by using the symbolic names VCGn, V(VCGn), I(VCGn), and P(VCGn), respectively.

2.3 Capacitor

The format for a capacitor is:

Cn (p) a b Cvalue

where: Cn = element ID
p = optional parallel segment designation
a and b = node names
Cvalue = capacitance value

The capacitor voltage v is given by

$$v = e_a - e_b$$

where e_a and e_b are the node voltages at nodes a and b, respectively.

The capacitor current i is given by

$$i = C \frac{dv}{dt} + v \frac{dC}{dt}$$

where C is the capacitance value.

The electric charge Q on the capacitor is given by

$$Q = Cv$$

The energy E stored in the electric field of the capacitor is given by

$$E = Cv^2/2$$

The user may reference the capacitance value, the capacitor voltage, the capacitor current, the electric charge, and the stored energy by using the symbolic names Cn, V(Cn), I(Cn), Q(Cn), and E(Cn), respectively.

2.4 Radiation Effects Capacitor

A special capacitor element is available for representing the effects of discharge and charge buildup due to gamma radiation effects. The format is:

RADCn (p) a b Cvalue, Dvalue, Bvalue

where: RADCn = element ID
p = optional parallel segment designation
a and b = node names
Cvalue = capacitance value
Dvalue = discharge coefficient value
Bvalue = charge buildup coefficient value

The capacitor voltage v is given by

$$v = e_a - e_b$$

where e_a and e_b are the node voltages at nodes a and b, respectively.

The voltage change Δv on the capacitor due to an incremental gamma dose $\Delta\gamma$ is given by

$$\Delta v = (-Dv + B)\Delta\gamma$$

where D is the discharge coefficient, B is the charge buildup coefficient, and v is the capacitor voltage before the discharge occurs. The incremental gamma dose is obtained automatically by NET from the user specified GAMMA or GAMDOT entries.

The capacitor current i is given by

$$i = C \frac{dv}{dt} + v \frac{dC}{dt}$$

where C is the capacitance value.

The electric charge Q on the capacitor is given by

$$Q = Cv$$

The energy E stored in the electric field of the capacitor is given by

$$E = Cv^2/2$$

The user may reference the capacitance value, the discharge coefficient value, the charge buildup coefficient value, the capacitor voltage, the capacitor current, the electric charge, and the stored energy by using the symbolic names RADCn, RADCn.1, RADCn.2, V(RADCn), I(RADCn), Q(RADCn), and E(RADCn), respectively.

2.5 Inductor

The inductor element consists of an inductance in series with a resistance. The format is:

Ln (p) a b Lvalue, Rvalue

where: Ln = element ID
p = optional parallel segment designation
a and b = node names
Lvalue = inductance value
Rvalue = resistance value

The resistance value is optionally specified; if it is not specified, NET-2 will supply .0001 as a default value. The resistance value may not assume a value of zero in the DC steady state solution, and the inductance value and the resistance value may not simultaneously assume a value of zero in transient solution or in an AC small signal calculation.

The inductor voltage v is given by

$$v = e_a - e_b$$

where e_a and e_b are the node voltages at nodes a and b, respectively.

The inductor current i is related to the voltage by the differential equation

$$v = L \frac{di}{dt} + i \frac{dL}{dt} + Ri$$

where L is the inductance value and R is the resistance value.

The magnetic flux F in the inductor is given by

$$F = Li$$

The energy E stored in the inductor is given by

$$E = Li^2/2$$

The user may reference the inductance value, the resistance value, the inductor voltage, the inductor current, the magnetic flux, and the stored energy by using the symbolic names Ln, Ln.l, V(Ln), I(Ln), F(Ln), and E(Ln), respectively.

2.6 Coefficient of Coupling

The coefficient of coupling entry is used if, and only if, mutual inductance exists between two inductors. This feature enables NET to handle circuits involving transformers. The format is:

Kn i j Value

where: Kn = coefficient of coupling ID
i and j = ID's of the inductors involved
Value = coefficient of coupling value. The magnitude of this value must always be less than one.

The value may be positive or negative, depending upon the manner in which the connections are specified in the description of the two inductors involved. To determine the proper sign, the inductors should be imagined as being connected in series with the b connection point of one joined to the a connection point of the other. If the resulting connection is such as to be aiding (i.e., inducing an in-phase voltage from one to the other and increasing the total inductance of the series pair), a positive sign is given to the value of the coefficient of coupling. Otherwise, the value is negative.

If the circuit includes several inductors with coupling among them, there must be a Coefficient of Coupling Entry for each pair combination.

An example involving three mutually coupled inductors is illustrated in Fig. 2-1. The phasing of the individual windings is indicated by the dots on the windings. A correct NET-2 description (using default series resistance in the inductors) is:

```
L1 1 2 35.6
L2 3 4 2.5
L3 5 6 4.8
K12 L1 L2 .985
K13 L1 L3 -.83
K23 L3 L2 -.75
```

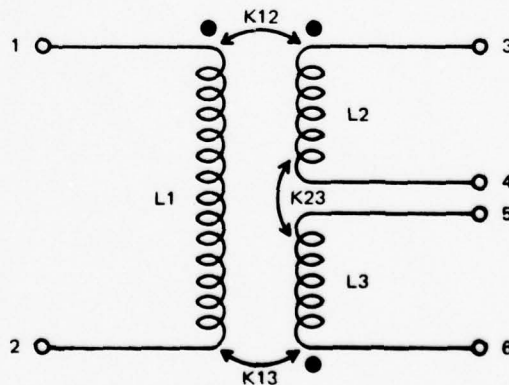

Figure 2-1. Mutual Inductance Example

The user may reference the coefficient of coupling value by using Kn as the symbolic name.

2.7 Switch

The switch is an ideal, zero impedance, single throw device. The format is:

Sn a b Value

where: Sn = switch ID
a and b = node names
Value = switch value

The switch is open when its value is zero or negative. It is closed when its value is greater than zero. The values of zero and one are useful because of their relationship to Boolean algebra.

The voltage v across the switch is given by

$$v = e_a - e_b$$

where e_a and e_b are the node voltages at nodes a and b , respectively.

The user may reference the switch value and the switch voltage by using the symbolic names S_n and $V(S_n)$, respectively.

2.8 Voltage Source

The voltage source consists of a zero impedance voltage generator in series with a resistance. The format for the voltage source is:

Vn (p) a b Evalue, Rvalue

where: Vn = element ID
p = optional parallel segment designation
a and b = node names
Evalue = voltage generator value
Rvalue = resistance value

The resistance value is optionally specified; if it is not specified NET-2 will supply .0001 as a default value. The resistance value may not assume a value of zero during any calculation.

The terminal voltage v of the voltage source element is given by

$$v = e_a - e_b$$

where e_a and e_b are the node voltages at nodes a and b, respectively.

The current i flowing in the voltage source is given by

$$i = \frac{E - v}{R}$$

where E is the voltage generator value and R is the resistance value.

The power dissipation P is given by

$$P = iv$$

The user may reference the voltage generator value, the resistance value, the terminal voltage, the current flow, and the power dissipation by using the symbolic names Vn, Vn.l, V(Vn), I(Vn), and P(Vn), respectively.

2.9 Voltage Controlled Voltage Source

A special element is available for describing a voltage source whose value is proportional to the voltage appearing across a node pair. This element consists of a zero impedance voltage generator in series with a resistance. The format is:

VCVSn (p) f g a b K, R

where: VCVSn = element ID

p = optional parallel segment designation

f and g = node pair node names

a and b = node names for element connection points

K = value of proportionality factor

R = resistance value

The resistance value is optionally specified; if it is not specified, NET-2 will supply .0001 as a default value. The resistance value may not assume a value of zero during any calculation.

The voltage controlled voltage source is inserted into the network between nodes a and b. The voltage generator value E is given by

$$E = K(e_f - e_g)$$

where e_f and e_g are the node voltages at nodes f and g, respectively.

The terminal voltage of the element is given by

$$v = e_a - e_b$$

where e_a and e_b are the node voltages at nodes a and b, respectively.

The current i flowing in the element is given by

$$i = \frac{E - v}{R}$$

The power dissipation P is given by

$$P = iv$$

The user may reference the value of the proportionality factor K, the resistance value R, the terminal voltage v, the current i, and the power P by using the symbolic names VCVSn, VCVSn.1, V(VCVSn), I(VCVSn), and P(VCVSn), respectively.

2.10 Current Source

The format for the current source is:

In (p) a b Value

where: In = element ID
p = optional parallel segment designation
a and b = node names
Value = current source value

The value of the source is always referred to node b. Thus, if a resistor with nodes a and b is connected across a positive valued source with the same nodes a and b, the voltage at node a will be more positive than the voltage at node b.

Current sources have zero internal admittance.

Care must be taken to avoid current source cutsets which violate Kirchhoff's current law. A current source cutset is present whenever any node has only current sources connected to it. Such configurations are automatically detected by NET-2. A diagnostic message is provided.

The voltage v across the current source is given by

$$v = e_a - e_b$$

where e_a and e_b are the node voltages at nodes a and b, respectively.

The power dissipation P is given by

$$P = iv$$

where i is the value of the current source.

The user may reference the current source value, the voltage v , and the power P by using the symbolic names In , $V(In)$, and $P(In)$, respectively.

2.11 Voltage Controlled Current Source

A special element is available for describing a current source whose value is proportional to the voltage appearing across a node pair. The format is:

VCCSn (p) f g a b K

where: VCCSn = element ID
p = optional parallel segment designation
f and g = node pair node names
a and b = node names for element connection points
K = value of proportionality factor

The current i flowing in the source is given by

$$i = K(e_f - e_g)$$

where e_f and e_g are the node voltages at nodes f and g , respectively.

The current flow value is always referred to node b . Thus, if a resistor with nodes a and b is connected across a source with positive current with the same nodes a and b , the voltage at node a will be more positive than the voltage at node b .

Care must be taken to avoid current source cutsets which violate Kirchhoff's current law. A current source cutset is present whenever any node has only current sources connected to it. Such configurations are automatically detected by NET. A diagnostic message will be provided.

The voltage v across the current source is given by

$$v = e_a - e_b$$

where e_a and e_b are the node voltages at nodes a and b , respectively.

The power dissipation P is given by

$$P = iv$$

The user may reference the value of the proportionality factor K , the current i , the voltage v , and the power dissipation P by using the symbolic names VCCSn, I(VCCSn), V(VCCSn), and P(VCCSn), respectively.

2.12 Nonlinear Voltage Controlled Current Source

A special element is available for describing a current source whose value is an empirical function of the voltage appearing across the current source. The format is:

NLVCCSn (p) TABLEm a b

where: NLVCCSn = element ID
p = optional parallel segment designation
TABLEm = ID for one-dimensional table involved
a and b = node names

The empirical nonlinear relationship is expressed by TABLEm. The current i flowing in the source is given by

$$i = \text{TABLEm}(e_a - e_b)$$

where e_a and e_b are the node voltages at nodes a and b, respectively.

The current flow value is always referred to node b. Thus, if a resistor with nodes a and b is connected across a source with positive current with the same nodes a and b, the voltage at node a will be more positive than the voltage at node b.

The voltage v across the current source is given by

$$v = e_a - e_b$$

The power dissipation P is given by

$$P = iv$$

The user may reference the current i , the voltage v , and the power dissipation P by using the symbolic names $I(\text{NLVCCSn})$, $V(\text{NLVCCSn})$, and $P(\text{NLVCCSn})$, respectively.

2.13 Primary Photocurrent Generator

NET-2 includes a primary photocurrent generator as a circuit element. Many of the modeled devices already include this element as part of the model. The availability of this circuit element enhances the radiation effects capability of NET-2. The element has zero admittance.

The format for the primary photocurrent generator is:

IPPn (p) a b A_1, A_2, A_3

where: IPPn = element ID
 p = optional parallel segment designation
 a and b = node names
 A_1, A_2, A_3 = coefficient values

The value of the photocurrent generator i for a single carrier type (usually minority carriers) is given by theory as

$$i(t) = A_1 g(t) + A_2 \int_0^t g(t-\lambda) \frac{e^{-\lambda/A_3}}{\sqrt{\pi\lambda}} d\lambda$$

where $g(t)$ is the rate at which energy from gamma radiation is received as a function of time. In practice it is very laborious to compute this convolution integral. Accordingly, the integral is approximated in NET-2 as follows: Let $g(t)$ be discretized as a series of step functions g_j at time T_j

$$g(t) = \sum_j g_j u(t-T_j)$$

$$\text{where } g_j = g(T_j^+) - g(T_{j-1}^+)$$

$$\text{and } g(t) = g(0) \text{ for } t \leq 0.$$

The current i is then given by

$$i(t) = A_1 g(t) + A_2 \sum_j g_j u(t-T_j) \operatorname{erf} \sqrt{\frac{t-T_j}{A_3}}$$

NET-2 approximates the error function as

$$\operatorname{erf} \sqrt{x} \approx 1 - e^{-2x}$$

The error introduced in using this approximation is shown in Fig. 2-2. The relative error is greatest for small values of x , which corresponds to small values of time or large values of A_3 .

The quantity $g(t)$ is specified by the GAMDOT Entry (or equivalently, the time derivative of the GAMMA Entry). If the duration of the gamma radiation pulse is short compared to t/A_3 in the above approximation, errors in the amplitude of i will result. The user can compensate for this error by modifying the value of coefficient A_2 .

The time step used in integrating the transient response will also be used in forming the discrete steps for the $g(t)$ radiation pulse. Thus, a time step of 1 nanosecond causes $g(t)$ to be approximated as a series of step functions, with an interval of 1 nanosecond between steps. The error function approximation given above leads to a first order differential equation which is integrated by NET-2 to give the primary photocurrent value.

The value of the primary photocurrent generator is always referred to node b. Thus, if a resistor with nodes a and b is connected across a positive valued photocurrent generator with the same nodes a and b, the voltage at node a will be more positive than the voltage at node b.

Care must be taken to avoid current source cutsets which violate Kirchoff's current law. A current source cutset is present whenever any node has only current sources connected to it. Such configurations are automatically detected by NET-2. A diagnostic message is provided.

The voltage across the current source is given by

$$v = e_a - e_b$$

where e_a and e_b are the node voltages at nodes a and b, respectively.

The power dissipation P is given by

$$P = iv$$

The user may reference the coefficient A_1 , the coefficient A_2 , the coefficient A_3 , the current i , the voltage v , and the power dissipation P by using the symbolic names IPPn, IPPn.1, IPPn.2, I(IPPn), V(IPPn), and P(IPPn), respectively.

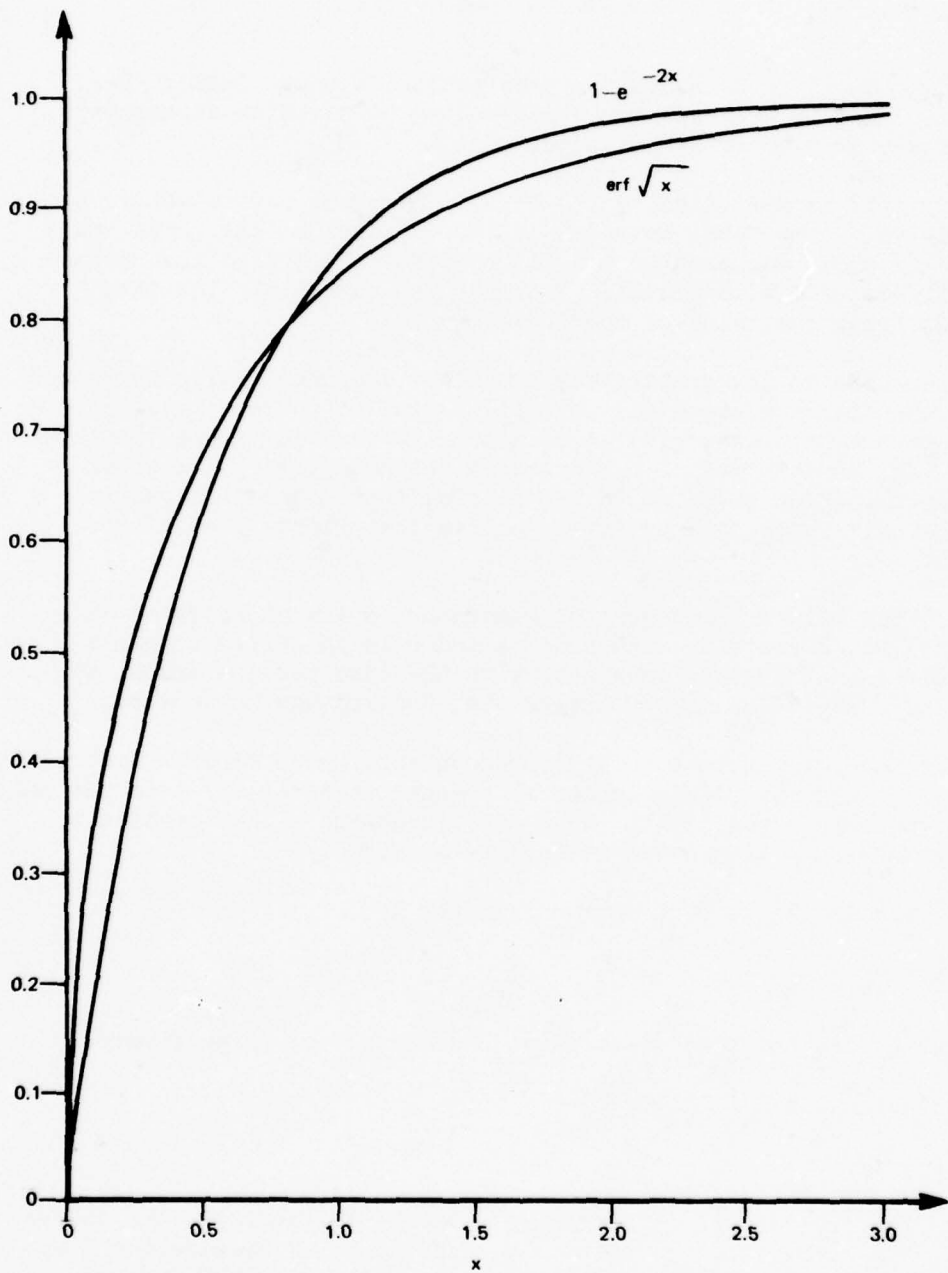

Figure 2-2. Error Function Approximation

2.14 Transmission Line

NET-2 contains a model for a two-wire uniform transmission line. The format is:

TLINEn (p) a b c m Z, T, R

where: TLINEn = element ID
p = optional parallel segment designation
a = node name for terminal node a
b = node name for terminal node b
c = node name for common terminal node
m = internal buffer size (must be an integer numerical constant)
Z = value of characteristic line impedance
T = delay time value for a one-way traversal of line
R = value of series line resistance between nodes a and b

The transmission line model can be considered to be equivalent to a lumped parameter LC section line containing m sections. The total series resistance R can be considered to be distributed along the line so that each inductor in the LC equivalent has a series resistance of R/m. The series resistance must not assume a value of zero during the DC steady state calculation. The series line resistance is ignored (i.e., a zero value is assumed) in the AC small signal calculation. The series resistance specification is optional; NET-2 will supply .0001 as a default value.

The transmission line has two ports, formed by nodes a and c on one end of the line, and by nodes b and c on the other end of the line. Nodes a and b are completely interchangeable.

Information is stored in the line at successive values of time, where the average time between successive information values is T/m. The element contains an internal buffer for purposes of storing the information. The internal buffer size m specifies the maximum number of time points which may be stored in the element at any one time. Increasing the buffer size requires additional computer core storage space but does not appreciably alter the computation time.

The transmission line model may be coupled to any kind of load, including nonlinear and reactive loads. It may also be connected to other transmission line elements. The model exhibits the proper reflection and transmission behavior.

The user may reference the characteristic impedance Z, the time delay T, the series resistance R, the terminal current flowing into node a, the terminal current flowing into node b, and the terminal current flowing into node c by using the symbolic names TLINEn, TLINEn.1, TLINEn.2, IA(TLINEn), IB(TLINEn), and IC(TLINEn), respectively.

2.15 Junction Diode

NET-2 contains a model for a junction diode with optional radiation effects. The model may be considered to be either Ebers-Moll or charge control in form, since these are merely equivalent ways of representing the same equations. Radiation effects are included automatically whenever a neutron or gamma radiation source is specified in the input.

The model exhibits normal forward conduction and reverse cutoff behavior. Storage time effects are included.

The model does not include junction breakdown at large reverse voltages. Conductivity modulation of the base region is not included.

The junction diode is a modeled device and requires device parameters in the Device Parameter Library. The model number is 1.

The format for the junction diode is:

Dn (p) A K Type

where: Dn = diode ID
p = optional parallel segment designation
A = anode node name
K = cathode node name
Type = alphanumeric type name

2.15.1 Equivalent Circuit

The diode model is represented by the equivalent circuit shown in Fig. 2-3.

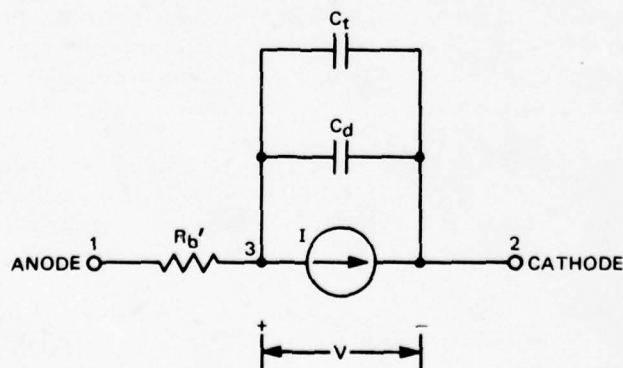

Figure 2-3. Junction Diode Equivalent Circuit

The current generator I depends upon junction voltage v as

$$I = I_s (1 + K_{Is} \phi(t)) (e^{\Theta v} - 1) - I_{pp}(t) + G_c v$$

where $\phi(t)$ is the total neutron dose received by time t as specified by the time integral of the neutron rate specified by the NEUT Entry.

The primary photocurrent $I_{pp}(t)$ is given as

$$I_{pp}(t) = I_{p1} g(t) \left(1 - \min \left(\frac{v}{V_z}, .9 \right) \right)^N + I_{p2} \int_0^t g(t-\lambda) \frac{e^{-\frac{\lambda}{T}}}{\sqrt{\pi\lambda}} d\lambda$$

where $g(t)$ is the gamma rate due to the gamma radiation source, and the convolution integral is approximated in the same manner as for the primary photocurrent generator circuit element (see 2.13).

The transition capacitance C_t is given by

$$C_t = C \left(1 - \min \left(\frac{v}{V_z}, .9 \right) \right)^{-N}$$

The diffusion capacitance is given by

$$C_d = \frac{\Theta I_s (1 + K_{Is} \phi(t)) e^{\Theta v}}{\omega + K_{\omega} \phi(t)}$$

The resistance R'_b is given by

$$R'_b = R_b e^{K_{Rb} \phi(t)}$$

2.15.2 Junction Diode References

The symbols used by NET to represent the junction diode circuit elements and parameters are given in Table 2-1. The user may control and reference any quantity for which a NET symbol has been assigned. Certain indicated parameters are not required by NET unless radiation effects behavior is being calculated. Only numerical constants may be used for parameter values.

Reference to a device parameter within the LIBRARY Entry is accomplished by simply using the symbolic parameter name. References in all other entries are made using the symbolic name Dn.x where x is the parameter name.

Node 3 in the diode model is available for connection purposes using Dn.3 as the node name. The node voltage may be referenced by using N(Dn.3) as the symbolic name.

The user may reference the anode-cathode voltage, anode terminal current, and diode power dissipation by using the symbolic names V(Dn), I(Dn), and P(Dn), respectively.

Table 2-1
Junction Diode Symbols (Model 1)

Equation Symbol	Name	NET Symbol	NET Units	Default Value	Comments
C	Transition capacitance at $v = 0$	C	pf	5	
G_c	Ohmic leakage admittance	GC	mmhos	1E-6	
I_{p1}	Photocurrent constant	IP1	pc/pj	0	Reqd for rad effects only
I_{p2}	Photocurrent constant	IP2	ma \sqrt{ns} /pj	0	Reqd for rad effects only
I_s	Saturation current	IS	ma	1E-9	IS > 0
K_{Is}	Saturation current damage constant	KIS	neut ⁻¹	0	Reqd for rad effects only
K_{Rb}	Bulk resistance damage constant	KRB	neut ⁻¹	0	Reqd for rad effects only
K_w	Diffusion capacitance damage constant	KW	neut ⁻¹	0	Reqd for rad effects only
N	Grading constant	N	none	0.3	
R_b	Bulk resistance	RB	kohms	1E-4	
T	Minority carrier lifetime	T	ns	0	
θ	Emission constant	TH	v ⁻¹	30	Reqd for rad effects only T > 0
V_z	Contact potential	VZ	v	1	VZ > 0
ω	Diffusion capacitance constant	W	ns ⁻¹	0.1	W > 0

2.15.3 Junction Diode Data Reduction

The user is referred to Section 9.1.2.1 for a general discussion of the data reduction feature. Specific details for the junction diode are given below.

NET-2 contains data reduction capability for obtaining parameters which describe the DC steady state characteristics of the junction diode and the diode transition capacitance.

The two types of data reduction available are summarized in Table 2-2. This table lists the data reduction type code, the symbols for the parameter values which are calculated, and the quantities which must be specified for each data reduction type.

drtype	Description	Input Data Sequence	Parameters Calculated
DC	DC characteristic	V, I, Wgt	IS, RB, TH, GC
CT	Transition Capacitance Curve	V, Ct, Wgt	C, N, VZ

Table 2-2. Junction Diode Data Reduction Types

In the input data a positive voltage corresponds to a forward bias on the diode junction and is associated with a positive terminal current. If reverse bias data is not provided for the DC data reduction, the value of parameter GC will not be calculated.

Any of the applicable parameter symbols may be used in the fixedparams and startparams fields on the DATA card for a given type of data reduction. However, specification of GC in the startparams field will be ignored by NET-2.

2.16 Zener Diode

NET-2 contains a model for the Zener diode with optional radiation effects. The model is an extension of the junction diode model. Radiation effects are automatically included whenever a neutron or gamma radiation source is specified in the input.

This model exhibits normal forward conduction, reverse cutoff, and Zener breakdown behavior and includes storage time effects. Conductivity modulation of the base region is not included.

The Zener diode is a modeled device and requires device parameters in the Device Parameter Library. The model number is 2.

The format for the Zener diode is:

ZDn (p) A K Type

where: ZDn = diode ID
p = optional parallel segment designation
A = anode node name
K = cathode node name
Type = device type name

2.16.1 Equivalent Circuit

The Zener diode model is represented by the equivalent circuit shown in Fig. 2-4.

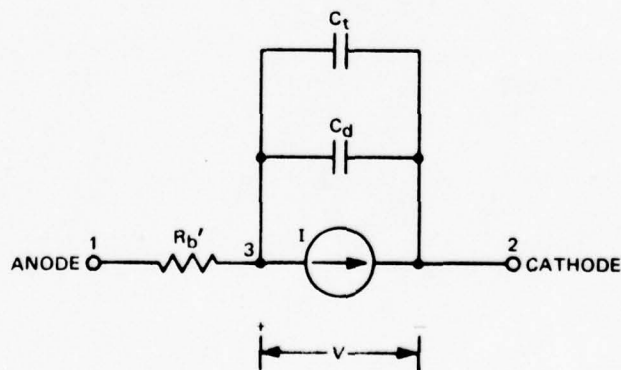

Figure 2-4. Zener Diode Equivalent Circuit

The current generator I depends upon junction voltage v as

$$I = I_s(1 + K_{Is}\phi(t))(e^{\Theta v} - 1) - e^{\frac{A(V_b - Bv)}{V_z}} - I_{pp}(t) + G_c v$$

where $\phi(t)$ is the total neutron dose received by time t as specified by the time integral of the neutron rate specified by the NEUT Entry.

The primary photocurrent $I_{pp}(t)$ is given as

$$I_{pp}(t) = I_{p1}g(t) \left(1 - \min\left(\frac{v}{V_z}, .9\right)\right)^N + I_{p2} \int_0^t g(t-\lambda) \frac{e^{-\frac{\lambda}{T}}}{\sqrt{\pi\lambda}} d\lambda$$

where $g(t)$ is the gamma rate due to the gamma radiation source, and the convolution integral is approximated in the same manner as for the primary photocurrent generator circuit element (see 2.13).

The transition capacitance C_t is given by

$$C_t = C \left(1 - \min\left(\frac{v}{V_z}, .9\right)\right)^{-N}$$

The diffusion capacitance is given by

$$C_d = \frac{\Theta I_s(1 + K_{Is}\phi(t))e^{\Theta v}}{\omega + K_{\omega}\phi(t)}$$

The resistance R'_b is given by

$$R'_b = R_b e^{K_{Rb}\phi(t)}$$

2.16.2 Zener Diode References

The symbols used by NET to represent the Zener diode device parameters are given in Table 2-3. The user may control and reference any quantity for which a NET symbol has been assigned. Certain indicated parameters are not required by NET unless radiation effects behavior is being calculated. Only numerical constants may be used for parameter values.

Reference to a device parameter within the LIBRARY Entry is accomplished by simply using the symbolic parameter name. References in all other entries are made using the symbolic name ZDn.x where x is the parameter name.

Node 3 in the Zener diode model is available for connection purposes using ZDn.3 as the node name. The node voltage may be referenced by using N(ZDn.3) as the symbolic name.

The user may reference the anode-cathode voltage, anode terminal current, and diode power dissipation by using the symbolic names V(ZDn), I(ZDn), and P(ZDn), respectively.

Table 2-3
Zener Diode Symbols (Model 2)

Equation Symbol	Name	NET Symbol	NET Units	Default Value	Comments
A	Zener breakdown constant	A	v ⁻¹	15	A > 0
B	Zener breakdown constant	B	none	1	B > 0
C	Transition capacitance at v = 0	C	pf	5	
G _c	Ohmic leakage admittance	GC	mmho	1E-6	
I _{p1}	Photocurrent constant	IP1	pc/pj	0	Reqd for rad effects only
I _{p2}	Photocurrent constant	IP2	ma \sqrt{ns} /pj	0	Reqd for rad effects only
I _s	Saturation current	IS	ma	1E-9	IS > 0
K _{Is}	Saturation current damage constant	KIS	neut ⁻¹	0	Reqd for rad effects only
K _{Rb}	Bulk resistance damage constant	KRB	neut ⁻¹	0	Reqd for rad effects only
K _w	Diffusion capacitance damage constant	KW	neut ⁻¹	0	Reqd for rad effects only
N	Grading constant	N	none	0.3	
R _b	Bulk resistance	RB	kohms	1E-4	RB \neq 0
T	Minority carrier lifetime	T	ns	0	Reqd for rad effects only T > 0
θ	Emission constant	TH	v ⁻¹	30	
V _b	Zener breakdown voltage	VB	v	-10	VB \leq 0
V _Z	Contact potential	VZ	v	1	VZ > 0
w	Diffusion capacitance constant	W	ns ⁻¹	0.1	W > 0

2.16.3 Zener Diode Data Reduction

The user is referred to Section 9.1.2.1 for a general discussion of the data reduction feature. Specific details for the Zener diode are given below.

NET-2 contains data reduction capability for obtaining parameters which describe the DC steady state characteristics of the Zener diode and the diode transition capacitance.

The two types of data reduction available are summarized in Table 2-4. This table lists the data reduction type code, the symbols for the parameter values which are calculated, and the quantities which must be specified for each data reduction type.

drtype	Description	Input Data Sequence	Parameters Calculated
DC	DC characteristic	V, I, Wgt	IS, RB, TH, GC, A, B, VB
CT	Transition Capacitance Curve	V, Ct, Wgt	C, N, VZ

Table 2-4. Zener Diode Data Reduction Types

In the input data a positive voltage corresponds to a forward bias on the diode junction, and is associated with a positive terminal current.

Any of the applicable parameter symbols may be used in the fixedparams and startparams fields on the DATA card for a given type of data reduction. However, specification of GC, A, B, or VB in the startparams field will be ignored by NET-2.

If data in the forward region is not included for the DC data reduction type, the parameters IS, TH, and RB will not be calculated; similarly, if data in the reverse region is not included, the parameters A, B, VB, and GC are not calculated. Data in the breakdown region must be supplied if meaningful values for A, B, and VB are to be calculated.

2.17 Tunnel Diode

NET-2 contains a model for a tunnel diode with optional radiation effects. These radiation effects are included automatically whenever a neutron or gamma radiation source is specified in the input.

This model exhibits the normal forward tunnel diode behavior with the familiar negative resistance region. Reverse region behavior is also represented.

The tunnel diode is a modeled device and requires device parameters in the Device Parameter Library. The model number is 3.

Stable solutions will be found only in the positive slope region for cases when the circuit load line intersects both the positive slope and the negative slope regions.

The format for the tunnel diode is:

TDn (p) A K Type

where: TDn = tunnel diode ID
p = optional parallel segment designation
A = anode node name
K = cathode node name
Type = tunnel diode type name

2.17.1 Equivalent Circuit

The tunnel diode model is represented by the equivalent circuit shown in Fig. 2-5.

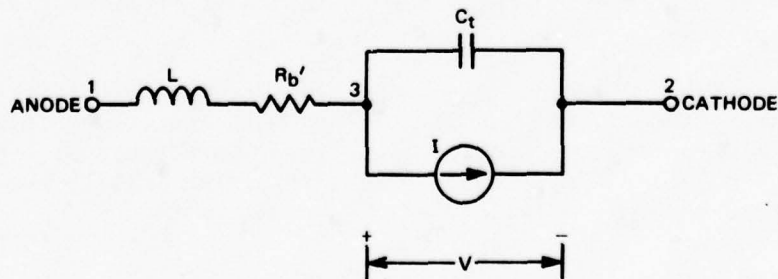

Figure 2-5. Tunnel Diode Equivalent Circuit

The current generator I depends upon junction voltage v as

$$I = A v e^{a_1 v} + B \left(e^{b_1 v} - e^{-b_2 v} \right) + C(1 + K_c \phi(t)) \left(e^{c_1 v} - 1 \right) - I_{pp}(t)$$

where $\phi(t)$ is the total neutron dose received at time t as specified by the time integral of the neutron dose specified by the NEUT Entry.

The primary photocurrent $I_{pp}(t)$ is given as

$$I_{pp}(t) = I_{p1} g(t) \left(1 - \min \left(\frac{v}{V_z}, .9 \right) \right)^N + I_{p2} \int_0^t g(t-\lambda) \frac{e^{-\frac{\lambda}{T}}}{\sqrt{\pi \lambda}} d\lambda$$

where $g(t)$ is the gamma rate due to the gamma radiation source, and the convolution integral is approximated in the same manner as for the primary photocurrent generator circuit element (see 2.13).

The transition capacitance is given by

$$C_t = C_o \left(1 - \min \left(\frac{v}{V_z}, .9 \right) \right)^{-N}$$

The resistance R'_b is given by

$$R'_b = R_b e^{K_{RB} \phi(t)}$$

The value of the inductance L is constant.

The node between the series inductance L and the series resistance R_b cannot be accessed by the user.

2.17.2 Tunnel Diode References

The symbols used by NET-2 to represent tunnel diode device parameters are given in Table 2-5. The user may control and reference any quantity for which a NET symbol has been assigned. Certain indicated parameters are not required by NET unless radiation effects behavior is being calculated. Only numerical constants may be used for parameter values.

Reference to a device parameter within the LIBRARY Entry is accomplished by simply using the symbolic parameter name. References in all other entries are made using the symbolic name TDn.x where x is the parameter name.

Node 3 in the tunnel diode model is available for connection purposes using TDn.3 as the node name. The node voltage may be referenced by using N(TDn.3) as the symbolic name.

Table 2-5
Tunnel Diode Symbols (Model 3)

Equation Symbol	Name	NET Symbol	NET Units	Default Value	Comments
A	Current generator coefficient	A	mmho	40	
a ₁	Current generator coefficient	A1	v ⁻¹	15	
B	Current generator coefficient	B	ma	0.1	
b ₁	Current generator coefficient	B1	v ⁻¹	2.5	
b ₂	Current generator coefficient	B2	v ⁻¹	2.5	
C	Current generator coefficient	C	ma	1E-9	
C ₀	Transition capacitance at v = 0	CO	pf	1	
c ₁	Current generator coefficient	C1	v ⁻¹	30	
I _{p1}	Photocurrent constant	IP1	pc/pj	0	Reqd for rad effects only
I _{p2}	Photocurrent constant	IP2	ma/ns/pj	0	Reqd for rad effects only
K _C	Saturation current damage constant	KC	neut ⁻¹	0	Reqd for rad effects only
K _{Rb}	Bulk resistance damage constant	KRB	neut ⁻¹	0	Reqd for rad effects only
L	Series inductance	L	ph	1E-4	
N	Grading constant	N	none	0.3	
R _b	Bulk resistance	RB	kohms	1E-3	RB ≠ 0
T	Minority carrier lifetime	T	ns	0	Reqd for rad effects only T > 0
V _Z	Contact potential	VZ	v	1	VZ > 0

2.17.3 Tunnel Diode Data Reduction

The user is referred to Section 9.1.2.1 for a general discussion of the data reduction feature. Specific details for the tunnel diode are given below.

NET-2 contains data reduction capability for obtaining parameters which describe the DC steady state characteristics of the tunnel diode and the diode transition capacitance.

The two types of data reduction available are summarized in Table 2-6. This table lists the data reduction type code, the symbols for the parameter values which are calculated, and the quantities which must be specified for each data reduction type.

drtype	Description	Input Data Sequence	Parameters Calculated
DC	DC forward characteristic	V, I, Wgt	A, A1, B, B1, B2, C, C1, RB
CT	Transition Capacitance Curve	V, Ct, Wgt	CO, N, VZ

Table 2-6. Tunnel Diode Data Reduction Types

In the input data a positive voltage corresponds to a forward bias on the diode junction and is associated with a positive terminal current. Reverse bias data is not used for the DC steady state characteristic.

Ideally, the DC steady state characteristic curve should consist of closely-spaced points, beginning near the origin and extending well into the normal diode region. As a minimal requirement, the curve should include four data points in each of the three regions of the forward characteristic curve.

Data in the negative resistance region is desirable but not mandatory. In the absence of information in this region, the calculated characteristic curve will be smooth, but may not accurately approximate the device in the vicinity of the negative resistance region.

Any of the applicable parameter symbols may be used in the fixedparams and startparams fields on the DATA card for a given type of data reduction.

2.18 Bipolar Transistor

NET-2 contains a model for a bipolar transistor with optional radiation effects. This model may be considered to be either an Ebers-Moll or charge control model, since these are merely equivalent ways of representing the same equations. Radiation effects are included automatically whenever a neutron or gamma radiation source is specified in the input.

This model includes behavior in the active normal, active inverted, saturated and cutoff region. Storage time effects are included. There is no breakdown of emitter-base or collector-base junction with reverse voltage. The base spreading resistance is constant and there is no dependence of emitter-base or collector-base diffusion capacitance with collecting voltage. The normal and inverted current gains may be functions of emitting junction voltage.

The same model is used for both PNP and NPN devices. Specification of PNP or NPN is made by setting a device parameter.

The bipolar transistor is a modeled device and requires device parameters in the Device Parameter Library. The model number is 4.

The format for the bipolar transistor is:

Tn (p) E B C Type Mode

where: Tn = transistor ID
p = optional parallel segment designation
E = emitter node name
B = base node name
C = collector node name
Type = device type name
Mode = optional mode designation

The optional mode designation may be used to assist NET-2 in obtaining the correct DC steady state solution when a bipolar transistor is involved in a bistable circuit configuration. The word OFF is the only legal mode designation available for this element; it is used to instruct NET-2 to maintain the specified transistor in the cutoff condition during the DC steady state solution. The cutoff constraint is automatically removed during the transient solution. The mode designation may be superseded in a specific State, Monte Carlo, or Optimization calculation. Blind use of the word OFF in unnecessary situations can lead to serious computational errors since transistor cutoff is always enforced by NET-2 in such situations.

2.18.1 Equivalent Circuit

The transistor model is represented by the equivalent circuit shown in Fig. 2-6, with polarities shown for an NPN device:

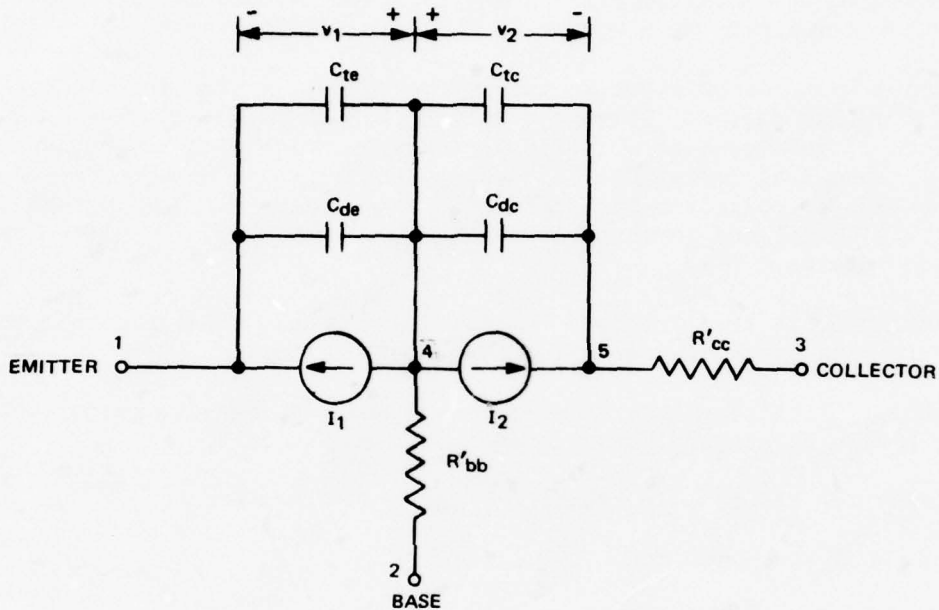

Figure 2-6. Bipolar Transistor Equivalent Circuit

The common emitter normal current gain β_n is given by a third degree polynomial in the emitter-base junction voltage v_1 (note that v_1 is proportional to the logarithm of the emitter current I_{ef} defined below)

$$\beta_n = B_n [A_1 + A_2 v_1 + A_3 (v_1)^2 + A_4 (v_1)^3] \quad 0 \leq v_1 \leq A$$

The constant A is the maximum value of v_1 for which the above polynomial expression is valid. For values of v_1 greater than A and for negative v_1 :

$$\beta_n = B_n [A_1 + A_2 A + A_3 A^2 + A_4 A^3] \quad v_1 > A$$

$$\beta_n = B_n A_1 \quad v_1 < 0$$

Similarly, the common collector inverted current gain β_i is given by a third degree polynomial in the collector-base junction voltage v_2 :

$$\beta_i = B_1 [B_1 + B_2 v_2 + B_3 (v_2)^2 + B_4 (v_2)^3] \quad 0 \leq v_2 \leq A$$

Again the constant A specifies the maximum value of v_2 for which the polynomial expression is valid. For values of v_2 greater than A and for negative v_2 :

$$\beta_i = B_i [B_1 + B_2 A + B_3 A^2 + B_4 A^3] \quad v_2 > A$$

$$\beta_i = B_i B_1 \quad v_2 < 0$$

The common base normal and inverted current gains may now be computed as

$$\alpha_n = \frac{\beta_n}{\beta_n (1 + K_{\alpha n} \phi(t)) + 1}$$

$$\alpha_i = \frac{\beta_i}{\beta_i (1 + K_{\alpha i} \phi(t)) + 1}$$

where the effects of neutron damage have now been incorporated. $\phi(t)$ is the total neutron dose received at time t as specified by the time integral of the neutron dose specified by the NEUT Entry.

The current emitted by the emitter, I_{ef} , is given by

$$I_{ef} = \frac{I_{es}}{1 - \alpha_n \alpha_i} (1 + K_e \phi(t)) \left(e^{\theta_1 v_1} - 1 \right)$$

Similarly, the current emitted by the collector, I_{cf} , is given by

$$I_{cf} = \frac{I_{cs}}{1 - \alpha_n \alpha_i} (1 + K_c \phi(t)) \left(e^{\theta_2 v_2} - 1 \right)$$

Assuming the emitter collects I_{cf} with an efficiency α_i we have for the current generator I_1

$$I_1 = I_{ef} - \alpha_i I_{cf} - I_{pp1}(t) + G_e v_1$$

where $I_{pp1}(t)$ is a primary photocurrent term given by

$$I_{pp1}(t) = I_{p11} g(t) \left(1 - \min \left(\frac{v_1}{V_{ze}}, .9 \right) \right)^{N_e} + I_{p12} \int_0^t g(t-\lambda) \frac{e^{-\lambda/T}}{\sqrt{\pi\lambda}} d\lambda$$

Similarly, assuming that the collector collects I_{ef} with an efficiency α_n we have for the current generator I_2

$$I_2 = I_{cf} - \alpha_n I_{ef} - I_{pp2}(t) + G_c v_2$$

where $I_{pp2}(t)$ is a primary photocurrent term given by

$$I_{pp2}(t) = I_{p21} g(t) \left(1 - \min \left(\frac{v_2}{V_{zc}}, .9 \right) \right)^{N_c} + I_{p22} \int_0^t g(t-\lambda) \frac{e^{-\lambda/T}}{\sqrt{\pi\lambda}} d\lambda$$

In the definition of primary photocurrents $g(t)$ is the gamma rate due to the gamma radiation source, and the convolution integral is approximated in the same manner as for the primary photocurrent generator circuit element (see 2.13).

The emitter transition capacitance is given by

$$C_{te} = C_e \left(1 - \min \left(\frac{v_1}{V_{ze}}, .9 \right) \right)^{-N_e}$$

Similarly, the collector transition capacitance is given by

$$C_{tc} = C_c \left(1 - \min \left(\frac{v_2}{V_{zc}}, .9 \right) \right)^{-N_c}$$

The emitter diffusion capacitance is given by

$$C_{de} = \frac{\frac{\theta_1 I_{es}}{1 - \alpha_n \alpha_i} (1 + K_e \phi(t)) e^{\theta_1 v_1}}{\omega_1 + K_{\omega 1} \phi(t)}$$

Similarly, the collector diffusion capacitance is given by

$$C_{dc} = \frac{\frac{\theta_2 I_{cs}}{1 - \alpha_n \alpha_i} (1 + K_c \phi(t)) e^{\theta_2 v_2}}{\omega_2 + K_{\omega 2} \phi(t)}$$

The resistances R'_{bb} and R'_{cc} are given as

$$R'_{bb} = R_{bb} e^{K_{Rb} \phi(t)}$$

$$R'_{cc} = R_{cc} e^{K_{Rc} \phi(t)}$$

The equations and equivalent circuit shown above refer to polarities for the NPN device. However, identical equations may be used for a PNP device if the polarities of v_1 and v_2 are reversed and the directions of current flow for I_1 and I_2 are reversed on the equivalent circuit. This reversal is done automatically by NET-2 so that the user needs only to specify whether an NPN or a PNP device is desired by appropriately setting the polarity parameter S in the device library. The signs of all parameter values except S remain unchanged when going from NPN to PNP.

2.18.2 Bipolar Transistor References

The symbols used by NET to represent the bipolar transistor device parameters are given in Table 2-7. The user may control and reference any quantity for which a NET symbol has been assigned. Certain indicated parameters are not required by NET unless radiation effects behavior is being calculated. Only numerical constants may be used for parameter values.

Reference to a device parameter within the LIBRARY Entry is accomplished by simply using the symbolic parameter name. References in all other entries are made using the symbolic name Tn.x where x is the parameter name.

The mode designation for a transistor may be altered from its original status using the name Tn.MODE followed by the word OFF or NONE. OFF establishes the cutoff mode for the transistor during the DC steady state calculation; NONE removes a previously established OFF mode.

Internal nodes 4 and 5 in the bipolar transistor model are available for connection purposes using Tn.y as the node name, where y is 4 or 5. The node voltage may be referenced by using N(Tn.y) as the symbolic name.

The user may reference the base-emitter voltage, the base-collector voltage, the collector-emitter voltage, the emitter current, the base current, the collector current, and the total transistor power dissipation by using the symbolic names VBE(Tn), VBC(Tn), VCE(Tn), IE(Tn), IB(Tn), IC(Tn), and P(Tn), respectively.

Table 2-7
Bipolar Transistor Symbols (Model 4)

Equation Symbol	Name	NET Symbol	NET Units	Default Value	Comments
A	Maximum voltage for gain polynomial	A	v	0	A > 0
A ₁	Normal current gain coefficient	A1	none	1	
A ₂	Normal current gain coefficient	A2	v ⁻¹	0	
A ₃	Normal current gain coefficient	A3	v ⁻²	0	
A ₄	Normal current gain coefficient	A4	v ⁻³	0	
B ₁	Inverted current gain coefficient	B1	none	1	
B ₂	Inverted current gain coefficient	B2	v ⁻¹	0	
B ₃	Inverted current gain coefficient	B3	v ⁻²	0	
B ₄	Inverted current gain coefficient	B4	v ⁻³	0	
B _i	Inverted current gain scale factor	B1	none	1	
B _n	Normal current gain scale factor	Bn	none	100	
C _c	Collector-base transition capacitance at v ₂ = 0	Cc	pf	5	
C _e	Emitter-base transition capacitance at v ₁ = 0	Ce	pf	5	
G _c	Collector-base ohmic leakage admittance	Gc	mmho	1E-6	
G _e	Emitter-base ohmic leakage admittance	Ge	mmho	1E-6	
I _{cs}	Collector-base saturation current	ICS	ma	1E-9	ICS > 0
I _{es}	Emitter-base saturation current	IES	ma	1E-9	IES > 0
I _{p11}	Emitter photocurrent constant	IP11	pc/pj	0	Reqd for rad effects only
I _{p12}	Emitter photocurrent constant	IP12	ma [√] ns/pj	0	Reqd for rad effects only
I _{p21}	Collector photocurrent constant	IP21	pc/pj	0	Reqd for rad effects only
I _{p22}	Collector photocurrent constant	IP22	ma [√] ns/pj	0	Reqd for rad effects only

Table 2-7

(Continued)

Equation Symbol	Name	NET Symbol	NET Units	Default Value	Comments
K_{ai}	Inverted current gain damage constant	KAI	neut ⁻¹	0	Reqd for rad effects only
K_{an}	Normal current gain damage constant	KAN	neut ⁻¹	0	Reqd for rad effects only
K_c	Collector saturation current damage constant	KC	neut ⁻¹	0	Reqd for rad effects only
K_e	Emitter saturation current damage constant	KE	neut ⁻¹	0	Reqd for rad effects only
K_{Rb}	R_{bb} damage constant	KRB	neut ⁻¹	0	Reqd for rad effects only
K_{Rc}	R_{cc} damage constant	KRC	neut ⁻¹	0	Reqd for rad effects only
$K_{\omega 2}$	Collector diffusion capacitance damage constant	KWC	neut ⁻¹	0	Reqd for rad effects only
$K_{\omega 1}$	Emitter diffusion capacitance damage constant	KWE	neut ⁻¹	0	Reqd for rad effects only
N_c	Collector-base grading constant	NC	none	0.3	
N_e	Emitter-base grading constant	NE	none	0.3	
R_{bb}	Base spreading resistance	RBB	kohm	1E-3	RBB \neq 0
R_{cc}	Collector bulk resistance	RCC	kohm	1E-4	RCC \neq 0
none	Device polarity constant	S	none	1	+1 for NPN, -1 for PNP
T	Minority carrier lifetime	T	ns	0	Reqd for rad effects only T > 0
θ_2	Collector current generator constant	THC	v ⁻¹	30	
θ_1	Emitter current generator constant	THE	v ⁻¹	30	
V_{zc}	Collector-base contact potential	VZC	v	1	VZC > 0
V_{ze}	Emitter-base contact potential	VZE	v	1	VZE > 0
ω_2	Collector diffusion capacitance constant	WI	ns ⁻¹	.01	WI > 0
ω_1	Emitter diffusion capacitance constant	WN	ns ⁻¹	0.1	WN > 0

2.18.3 Bipolar Transistor Data Reduction

The user is referred to Section 9.1.2.1 for a general discussion of the data reduction feature. Specific details for the bipolar transistor are given below.

NET-2 contains data reduction capability for obtaining parameters which describe the DC steady state characteristics of the bipolar transistor in cutoff, normal, inverted, and saturated regions of operation, and parameters which describe the emitter-base and collector-base transition capacitance.

The six types of data reduction available are summarized in Table 2-8. This table lists the data reduction type code, the symbols for the parameter values which are calculated, and the quantities which must be specified as data for each data reduction type.

drtype	Description	Input Data Sequence	Parameters Calculated
DCN	Normal DC characteristic	Vbe, Ib, Ic, Wgt	A, A1, A2, A3, A4, BN, GE, IES, RBB, THE
DCN1	Same as for DCN	Vbe, β_n , Ie, Wgt	Same as for DCN
DCI	Inverted DC characteristic	Vbc, Ib, Ie, Wgt	B1, B2, B3, B4, BI, GC, ICS, RCC, THC
DCI1	Same as for DCI	Vbc, β_i , Ic, Wgt	Same as for DCI
CTE	Emitter-base transition capacitance curve	Vbe, Cte, Wgt	CE, NE, VZE
CTC	Collector-base transition capacitance curve	Vbc, Ctc, Wgt	CC, NC, VZC

Table 2-8. Bipolar Transistor Data Reduction Types

The DCN and DCN1 data reduction types are identical except for the quantities which are required as input data. Similarly, the DCI and DCI1 types are identical except for the input data quantities. If DCN (or DCN1) and DCI (or DCI1) data reductions are both specified, reduction of the two sets of data will be performed alternately in order to obtain a consistent set of parameter values. The CTE and CTC data reductions are handled independently.

Due to the interdependence of the normal and inverted data reductions, special cases result if both sets of data are not submitted together. If only normal data is submitted, a value must be available for BI. Similarly, if only inverted data is submitted, a value must be available for both BN and RBB.

In the input data a positive voltage corresponds to a forward bias on the semiconductor junction and is associated with a positive terminal current. Inverted data is measured by operating the transistor with the emitter and collector leads exchanged. There is no distinction between PNP and NPN transistors in the input data sign conventions.

The user should attempt to supply data over as wide a range as is feasible. If data is not supplied near $v = 0$, the calculated beta polynomial may be negative or have a negative slope at small voltage values. When this happens, NET-2 will recalculate the coefficients using a method which constrains A1 and A2 to be non-negative, and an informative diagnostic will be printed, provided A1 (or B1) has not been specified in the startparams field.

Many options are available to the user for controlling the parameters A, A1, A2, A3, A4, B1, B2, B3, and B4. All specifications for these parameters in the startparams field are ignored by NET-2 except for the parameter A1 (or B1). The following general rules apply:

The parameter A is always equated to the most positive value of the internal junction voltage. If both normal and inverted DC calculations are made, A will be the lesser of the values calculated from the two sets of data. The parameter A cannot be fixed unless all other parameters A1, A2, A3, A4, B1, B2, B3, and B4 are also fixed.

The A1, A2, A3, and A4 coefficients (or B1, B2, B3, and B4 coefficients) must be fixed, in order, from one end of the polynomial or the other, but not both. For example, one cannot fix both A1 and A4; the result would be that A1 is fixed, A4 is not fixed.

If A1 (or B1) is fixed, then A2 (or B2) is the only other coefficient that may be fixed. If A2, A3, or A4 (or, alternatively, B2, B3, or B4) are fixed singly or in combination, the order of the polynomial curve fit is reduced; for example, A2 fixed implies $A3 = A4 = 0$.

A more detailed exposition of the above general rules follows below:

If A1 (or B1) is specified in the fixedparams field the final parameter value for A1 (or B1) will be that which was specified. If A1 (or B1) is specified in the startparams field, the final value for A1 (or B1) will be that required by the least squares fitting process. If the final value of either A1 (or B1) or A2 (or B2) is negative (implying a negative dip in the beta curve near the origin) a warning message will be printed but the values will not be recalculated. This is in contrast to the action which occurs when A1 (or B1) is not specified in the startparams field, whereby the parameters are recalculated to constrain A1 and A2 (or B1 and B2) to be non-negative if the normal least squares process causes either of them to be negative.

If A2 (or B2) is fixed, one of two actions may occur. If A1 (or B1) is also fixed, then the user is specifying a slope and intercept for the curve and the values of A3 and A4 (or B3 and B4) will be chosen to be consistent with the fixed values. If, however, A1 (or B1) is not fixed then the parameters A2, A3, and A4 (or B2, B3, and B4) will be set to zero and the arithmetic average for the beta curve will result.

If A3 (or B3) is fixed then NET-2 will set A3 and A4 (or B3 and B4) to zero, giving a linear fit, provided A1 (or B1) is not fixed. If A1 (or B1) is also fixed, then the fixed values of A3 (or B3) will be ignored.

If A4 (or B4) is fixed, then NET-2 will set A4 (or B4) to zero, giving a quadratic fit, provided A1 (or B1) is not also fixed. If A1 (or B1) is also fixed, then the fixed value of A4 (or B4) will be ignored.

The parameters IES, RBB, THE, ICS, RCC, and THC are calculated by an iterative linearized least squares analysis. Normally, NET-2 calculates initial values for these parameters by a linear approximation. However, the user may supply starting values for any or all of these parameters. These starting values will be used if the appropriate parameter symbol is included in the startparams field on the DATA card.

In general, it is recommended that the user permit NET-2 to calculate initial values, unless convergence problems are encountered.

2.19 MOS Field Effect Transistor

NET-2 contains a model for the MOS field effect transistor (MOSFET) with optional radiation effects. Radiation effects are automatically included whenever a neutron or gamma radiation source is specified in the input.

This model exhibits the very high gate input impedance normally found in MOSFETs. The model may represent either PNP or NPN structures, and may be operated in both the enhancement and depletion modes. Symmetric characteristics with respect to drain-source voltage polarity are observed.

The MOSFET is a modeled device and requires device parameters from the Device Parameter Library. The model number is 5.

The format for the MOSFET is:

MFETn (p) S G D SS Type

where: MFETn = MOSFET ID
 p = optional parallel segment designation
 S = source node name
 G = gate node name
 D = drain node name
 SS = substrate node name
 Type = MOSFET type name

2.19.1 Equivalent Circuit

The MOSFET model is represented by the equivalent circuit shown in Fig. 2-7.

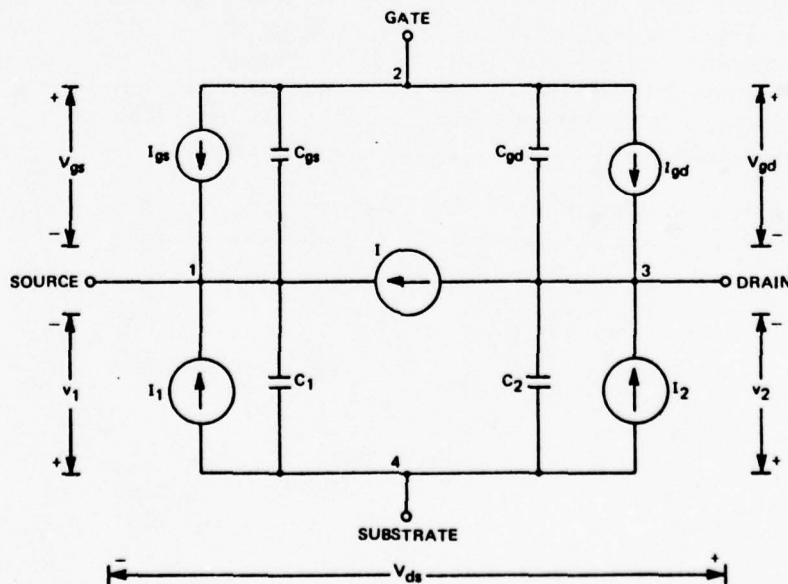

Figure 2-7. MOSFET Equivalent Circuit

The junction capacitances depend upon the gate-source voltage V_{gs} and the gate-drain voltage V_{gd} :

$$C_{gs} = C_{gs1}$$

$$V_{gs} < V_{g1}$$

$$= \frac{\sqrt{2} C_{gs1}}{\sqrt{1 + \frac{V_{gs}}{V_{g1}}}}$$

$$V_{g1} \leq V_{gs} \leq V_{g2}$$

$$= \frac{\sqrt{2} C_{gs1}}{\sqrt{1 + \frac{V_{g2}}{V_{g1}}}}$$

$$V_{gs} > V_{g2}$$

Similarly,

$$C_{gd} = C_{gd1}$$

$$V_{gd} < V_{gd1}$$

$$= \frac{\sqrt{2} C_{gd1}}{\sqrt{1 + \frac{V_{gd}}{V_{gd1}}}}$$

$$V_{gd1} \leq V_{gd} \leq V_{gd2}$$

$$= \frac{\sqrt{2} C_{gd1}}{\sqrt{1 + \frac{V_{gd2}}{V_{gd1}}}}$$

$$V_{gd2} < V_{gd}$$

The controlling equation for the current generator I is a function of the gate-source voltage V_{gs} and the drain-source voltage V_{ds} . Fig. 2-8 shows the V - I characteristic for the MOSFET (the characteristic is mirrored in the third quadrant for inverted operation). It is seen that the curve at constant V_{gs} consists of a rounded portion (region A) in the low V_{ds} region, and a flat almost constant current curve (region B) in the higher V_{ds} region.

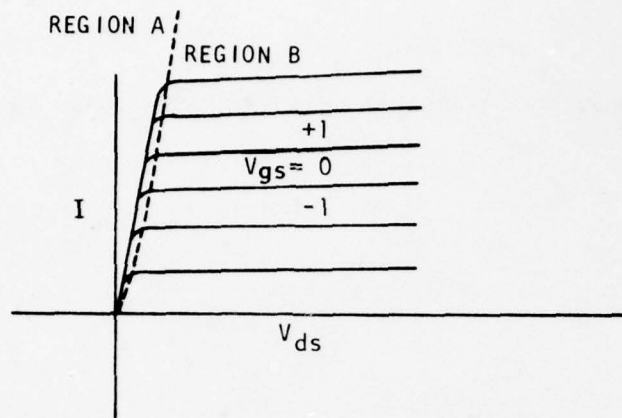

Figure 2-8. MOSFET Drain-Source Characteristics

Let the slope in region B be given by the general expression

$$\frac{\partial I}{\partial V_{ds}} = K_1 + K_2 V_{gs} + K_3 V_{gs}^2$$

Let the current in region A be given by

$$I = V_{ds} [A_1 + A_2 \sqrt{V_{ds}} + A_3 V_{ds} + V_{gs} (A_4 + A_5 V_{gs})]$$

Now define a locus of points, corresponding to different values V_{gs} , where the slope of the region A equation is equal to the slope in region B. This locus will occur at a value of $V_{ds} = V_0$, for a given value of V_{gs} , and is the boundary line between regions A and B. Thus, in region B:

$$I = (V_{ds} - V_o)(K_1 + K_2 V_{gs} + K_3 V_{gs}^2) + V_o [A_1 + A_2 \sqrt{V_o} + A_3 V_o + V_{gs} (A_4 + A_5 V_{gs})]$$

The current generators I_1 and I_2 correspond to conventional pn junction models, and are functions of the substrate-source voltage v_1 and substrate-drain voltage v_2 , respectively:

$$I_1 = I_{s1} (1 + K_{Is1} \phi(t)) \left(e^{\theta_1 v_1} - 1 \right) - I_{pp1}(t)$$

$$I_2 = I_{s2} (1 + K_{Is2} \phi(t)) \left(e^{\theta_2 v_2} - 1 \right) - I_{pp2}(t)$$

where $\phi(t)$ is the total neutron dose received by time t as specified by the time integral of the neutron rate specified by the NEUT Entry.

The primary photocurrents $I_{pp1}(t)$ and $I_{pp2}(t)$ are given by

$$I_{pp1}(t) = I_{p11} g(t) \left(1 - \min \left(\frac{v_1}{V_{z1}}, .9 \right) \right)^{N_1} + I_{p12} \int_0^t g(t-\lambda) \frac{e^{-\lambda/T}}{\sqrt{\pi\lambda}} d\lambda$$

$$I_{pp2}(t) = I_{p21} g(t) \left(1 - \min \left(\frac{v_2}{V_{z2}}, .9 \right) \right)^{N_2} + I_{p22} \int_0^t g(t-\lambda) \frac{e^{-\lambda/T}}{\sqrt{\pi\lambda}} d\lambda$$

where $g(t)$ is the gamma rate due to the gamma radiation source, and the convolution integral is approximated in the same manner as for the primary photocurrent generator circuit element (see 2.13).

The capacitances C_1 and C_2 contain both depletion and diffusion terms and are given by

$$C_1 = C_{01} \left(1 - \min \left(\frac{v_1}{V_{z1}}, .9 \right) \right)^{-N_1} + \frac{\theta_1 I_{s1} (1 + K_{Is1} \phi(t)) e^{\theta_1 v_1}}{\omega_1 + K_{\omega 1} \phi(t)}$$

$$C_2 = C_{02} \left(1 - \min \left(\frac{v_2}{V_{z2}}, .9 \right) \right)^{-N_2} + \frac{\theta_2 I_{s2} (1 + K_{Is2} \phi(t)) e^{\theta_2 v_2}}{\omega_2 + K_{\omega 2} \phi(t)}$$

The current generators I_{gs} and I_{gd} represent gate-source and gate-drain ionization from gamma radiation and are given by

$$I_{gs} = K_{gs} V_{gs} g(t)$$

$$I_{gd} = K_{gd} V_{gd} g(t)$$

The MOSFET model as described corresponds to an n channel device. NET-2 uses voltage polarities corresponding to normal operation of an n channel device for the MOSFET model. However, the user may specify either a p channel or an n channel device and NET-2 will automatically adjust the signs of the voltages and currents to account for the type of channel and also for inverted operation. The user need not be concerned with this sign manipulation.

2.19.2 MOSFET References

The symbols used by NET-2 to represent the MOSFET device parameters are given in Table 2-9. The user may control and reference any quantity for which a NET symbol has been assigned. Certain indicated parameters are not required by NET unless radiation effects behavior is being calculated. Only numerical constants may be used for parameter values.

Reference to a device parameter within the LIBRARY Entry is accomplished by simply using the symbolic parameter name. References in all other entries are made using the symbolic name MFETn.x where x is the parameter name.

Table 2-9
MOSFET Symbols (Model 5)

Equation Symbol	Name	NET Symbol	NET Units	Default Value	Comments
A ₁	Conductance parameter	A1	mmho	2	May be negative for enhancement device
A ₂	Conductance parameter	A2	$v^{-3/2}$ ma	0	
A ₃	Conductance parameter	A3	v^{-2} ma	-.25	
A ₄	Conductance parameter	A4	v^{-2} ma	.5	
A ₅	Conductance parameter	A5	v^{-3} ma	0	
C ₀₁	Substrate-source depletion capacitance at $v_1 = 0$	C01	pf	5	
C ₀₂	Substrate-drain depletion capacitance at $v_2 = 0$	C02	pf	5	
C _{gd1}	C _{gd} value at $v_{gs} = v_{gd}$	CGD1	pf	1	
C _{gs1}	C _{gs} value at $v_{gs} = v_{gs1}$	CGS1	pf	1	
I _{pl1}	Photocurrent constant	IP11	pc/pj	0	Reqd for rad effects only
I _{pd1}	Photocurrent constant	IP12	ma \sqrt{ns} /pj	0	Reqd for rad effects only
I _{pd2}	Photocurrent constant	IP21	pc/pj	0	Reqd for rad effects only
I _{pd2}	Photocurrent constant	IP22	ma \sqrt{ns} /pj	0	Reqd for rad effects only
I _{s1}	Substrate-source saturation current	IS1	ma	1E-9	IS1 > 0
I _{s2}	Substrate-drain saturation current	IS2	ma	1E-9	IS2 > 0
K ₁	Conductance parameter	K1	none	1E-4	
K ₂	Conductance parameter	K2	v^{-1}	0	
K ₃	Conductance parameter	K3	v^{-2}	0	
K _{gd}	Gate-drain ionization constant	KGD	mmhos/mv	0	Reqd for rad effects only

Table 2-9
(Continued)

Equation Symbol	Name	NET Symbol	NET Units	Default Value	Comments
K_{gs}	Gate-source ionization constant	XGS	mmhos/mv	0	Reqd for rad effects only
K_{Is1}	Saturation current damage constant	KIS1	neut ⁻¹	0	Reqd for rad effects only
K_{Is2}	Saturation current damage constant	KIS2	neut ⁻¹	0	Reqd for rad effects only
K_{w1}	Diffusion capacitance damage constant	KW1	neut ⁻¹	0	Reqd for rad effects only
K_{w2}	Diffusion capacitance damage constant	KW2	neut ⁻¹	0	Reqd for rad effects only
N_1	Substrate-source grading constant	N1	none	0.3	
N_2	Substrate-drain grading constant	N2	none	0.3	
none	Device polarity constant	S	none	1	+1 for N channel, -1 for P channel
T	Lifetime	T	ns	0	Reqd for rad effects only T > 0
θ_1	Substrate-source emission constant	TH1	v ⁻¹	30	
θ_2	Substrate-drain emission constant	TH2	v ⁻¹	30	
V_{g1}	C_{gs} voltage parameter	VG1	v	1	VG1 ≠ 0
V_{g2}	C_{gs} voltage parameter	VG2	v	1	
V_{gd1}	C_{gd} voltage parameter	VG1	v	1	VG1 ≠ 0
V_{gd2}	C_{gd} voltage parameter	VG2	v	1	
V_{z1}	Substrate-source contact potential	VZ1	v	1	VZ1 > 0
V_{z2}	Substrate-drain contact potential	VZ2	v	1	VZ2 > 0
ω_1	Substrate-source diffusion capacitance constant	W1	ns ⁻¹	0.1	W1 > 0
ω_2	Substrate-drain diffusion capacitance constant	W2	ns ⁻¹	0.1	W2 > 0

2.19.3 MOSFET Data Reduction

The user is referred to Section 9.1.2.1 for a general discussion of the data reduction feature. Specific details for the MOSFET are given below.

NET-2 contains data reduction capability for obtaining parameters which describe the DC steady state drain-source characteristic for the MOSFET. The data reduction is summarized in Table 2-10. This table lists the data reduction type code, the symbols for the parameter values which are calculated, and the quantities which must be specified for each data reduction type.

drtype	Description	Input Data Sequence	Parameters Calculated
DC	Drain-source DC characteristic	Vgs, Vds, Id, Wgt	A1, A2, A3, A4, A5, K1, K2, K3

Table 2-10. MOSFET Data Reduction Types

The polarity of the data must correspond to that for an n channel device as illustrated in Fig. 2-8. Complete drain-source characteristics should be supplied for at least three values of V_{gs} . It is important that the data be closely spaced about each knee so that the shapes are adequately described in these regions.

Any of the applicable parameter symbols may be used in the fixedparams field on the DATA card. All entries in the startparams field are ignored by NET-2.

If A1 is fixed, the calculation for A1, A4, and A5 will be omitted. If A2 is fixed, the calculation for A2 and A3 will be omitted. If A3 is fixed, the fixing of A3 will be ignored and a value will be calculated for A3. If A4 is fixed, values of zero will be used for A4 and A5. If A5 is fixed, a value of zero will be used for A5.

If K1 is fixed, the calculation for K1, K2, and K3 will be omitted. If K2 is fixed, a value of zero will be used for K2 and K3. If K3 is fixed, a value of zero will be used for K3.

2.20 Junction Field Effect Transistor

NET-2 contains a model for the junction field effect transistor (JFET) with optional radiation effects. Radiation effects are automatically included whenever a neutron or gamma radiation source is specified in the input.

The model may represent either PNP or NPN structures. Assymmetric characteristics are available with respect to drain-source voltage polarity.

The JFET is a modeled device and requires device parameters from the Device Parameter Library. The model number is 6.

The format for the JFET is:

JFETn (p) S G D Type

where: JFETn = JFET ID
p = optional parallel segment designation
S = source node name
G = gate node name
D = drain node name
Type = JFET type name

2.20.1 Equivalent Circuit

The JFET model is represented by the equivalent circuit shown in Fig. 2-9.

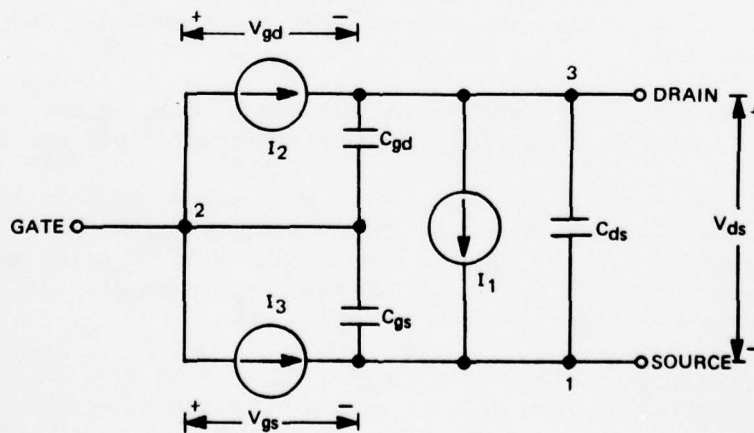

Figure 2-9. JFET Equivalent Circuit

The current generator I_1 represents the drain-source volt-ampere characteristic, where I_1 is a function of V_{ds} and V_{gs} . NET-2 uses voltage polarities corresponding to normal operation of an n channel device in the JFET model. Thus, the equations developed below represent normal n channel operation. NET-2 automatically adjusts the signs of voltages and currents to account for inverted operation and for p channel devices and the user need not be concerned with this sign manipulation.

The drain-source characteristic for normal n channel operation is shown in Fig. 2-10. The characteristic is divided into two regions, a low voltage "channel on" region where the current depends upon V_{ds} according to a power law, and a saturation region where the channel is pinched off and the characteristic is essentially resistive.

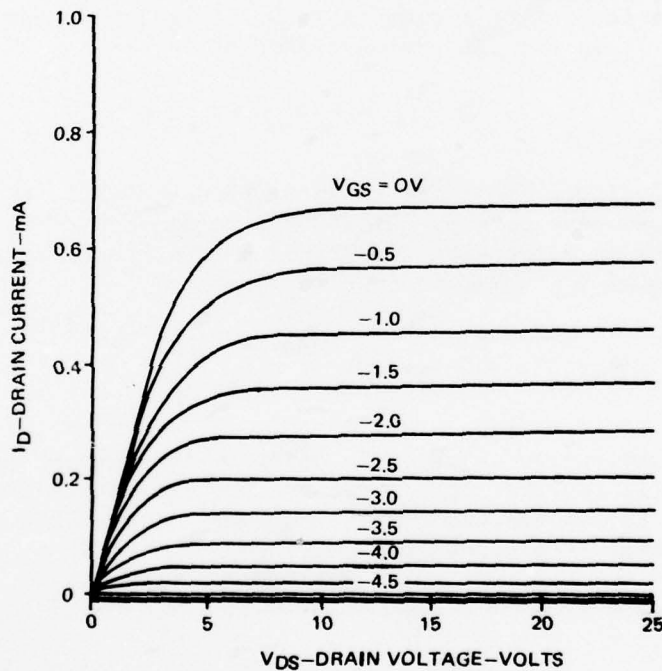

Figure 2-10. JFET Drain-Source Characteristics

The "channel on" conductance is defined as $G_o = \partial I_1 / \partial V_{ds}$ at $V_{ds} = 0$, and is given by a quadratic of the form

$$G_o = \left[G_{cc} + A_1(V_{gs} - V_{rc}) + A_2(V_{gs} - V_{rc})^2 \right] e^{-K_G \phi(t)}$$

where G_{cc} is the measured conductance at $V_{ds} = 0$ for $V_{gs} = V_{rc}$, and A_1 and A_2 are fitting parameters. $\phi(t)$ is the total neutron dose received by time t as specified by the time integral of the neutron rate specified by the NEUT Entry.

The conductance in the saturation region is modeled as an expression of the form

$$G_s = (S_1 + S_2 V_{gs} + S_3 V_{gs}^2) e^{-K_G \phi(t)}$$

where S_1 , S_2 , and S_3 are fitting parameters.

Let us now define the current I_1 as having a value I_{ds} at some fixed voltage $V_{ds} = V_{dst}$ which is well into the saturation region. Since the conductance of the saturation region is known to be G_s , we can now write an expression for I_1 in the saturation region as

$$I_1 = I_{ds} + G_s (V_{ds} - V_{dst})$$

This expression simply shows the linear dependence of I_1 on V_{ds} for a given value of V_{gs} . We have already defined the dependence of G_s on V_{gs} ; however, we still require an expression for I_{ds} as a function of V_{gs} , where I_{ds} is the value of I_1 at $V_{ds} = V_{dst}$. This is given by

$$I_{ds} = \left[G_1 + G_2 V_{gs} + G_3 V_{gs}^2 \right] e^{-K_{I_{ds}} \phi(t)}$$

We now have equations which uniquely describe the current in the saturation region. We still require expressions for the current in the channel "on" region as well as a definition of the boundary between the channel "on" region and the saturation or pinchoff region.

Let us define a pinch-off voltage V_p . Theoretically, the channel should pinch off right at this voltage. In practice, however, the actual value of V_{ds} where pinch off occurs can be greater than V_p . For this reason, a voltage called V_{sat} is introduced to represent that voltage at which the characteristic becomes resistive, governed by the conductance G_s . The expression for V_{sat} is

$$V_{sat} = V_k (V_{gs} - V_p)$$

where V_k is a fitting parameter. Thus V_{sat} depends upon V_{gs} , and a locus of values of V_{sat} exists for different V_{gs} values.

Finally, the expression for I_1 in the channel "on" region is given by

$$I_1 = G_o V_{ds} + B_1 V_{ds}^{B_2}$$

where the constants B_1 and B_2 are fitting parameters. Note that the slope of the characteristic at $V_{ds} = 0$ is equal to the channel "on" conductance G_o as required. The constants B_1 and B_2 are chosen by NET-2 such that I_1 and $\partial I_1 / \partial V_{ds}$ are continuous at $V_{ds} = V_{sat}$.

The quantities developed above are indicated in Fig. 2-11 to illustrate the concepts involved.

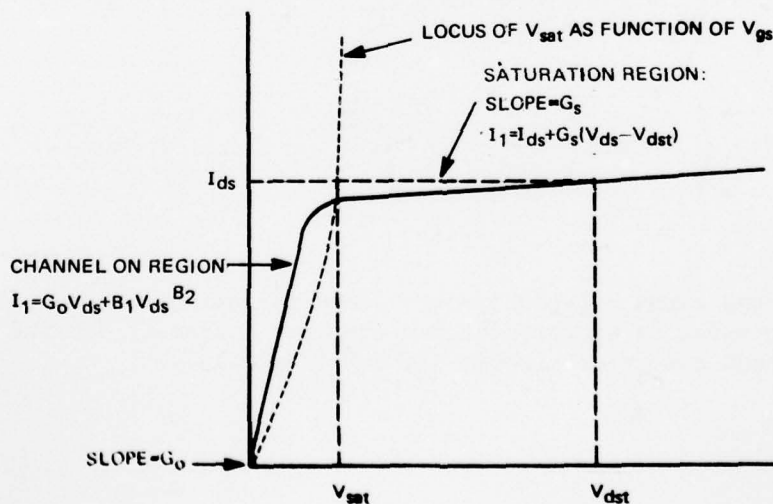

Figure 2-11. Illustration of JFET Model Parameters and Equations

Actually, NET-2 has the ability to represent different curves for the JFET in the normal and inverted modes of operation. This is accomplished by storing pairs of parameters for the constants V_p , V_k , G_1 , G_2 , G_3 , and V_{dst} . The selection of the correct value from the pair is done automatically by NET-2.

A capacitance C_{ds} exists across the drain-source terminals in the model. The value of this capacitance is constant.

The JFET model also contains two pn junctions. These junctions are modeled in a conventional manner, similar to the diode model.

The current generators I_2 and I_3 are given by

$$I_2 = I_{gdo} (1 + K_{Igd} \phi(t)) \left(e^{\theta_2 V_{gd}} - 1 \right) - I_{pp2}(t)$$

$$I_3 = I_{gso} (1 + K_{Igs} \phi(t)) \left(e^{\theta_3 V_{gs}} - 1 \right) - I_{pp3}(t)$$

The primary photocurrents $I_{pp2}(t)$ and $I_{pp3}(t)$ are given by

$$I_{pp2}(t) = I_{p21} g(t) \left(1 - \min \left(\frac{v_{gd}}{V_{zgd}}, .9 \right) \right)^{N_{gd}} + I_{p22} \int_0^t g(t-\lambda) \frac{e^{-\frac{\lambda}{T}}}{\sqrt{\pi\lambda}} d\lambda$$

$$I_{pp3}(t) = I_{p31} g(t) \left(1 - \min \left(\frac{v_{gs}}{V_{zgs}}, .9 \right) \right)^{N_{gs}} + I_{p32} \int_0^t g(t-\lambda) \frac{e^{-\frac{\lambda}{T}}}{\sqrt{\pi\lambda}} d\lambda$$

where $g(t)$ is the gamma rate due to the gamma radiation source, and the convolution integral is approximated in the same manner as for the primary photocurrent generator circuit element (see 2.13).

The capacitances C_{gd} and C_{gs} represent both depletion and diffusion effects and are given by

$$C_{gd} = C_{gdo} \left(1 - \min \left(\frac{V_{gd}}{V_{zgd}}, .9 \right) \right)^{-N_{gd}} + \frac{\theta_2 I_{gdo} (1 + K_{Igd} \phi(t)) e^{\theta_2 V_{gd}}}{\omega_2 + K_{\omega 2} \phi(t)}$$

$$C_{gs} = C_{gso} \left(1 - \min \left(\frac{V_{gs}}{V_{zgs}}, .9 \right) \right)^{-N_{gs}} + \frac{\theta_3 I_{gso} (1 + K_{Igs} \phi(t)) e^{\theta_3 V_{gs}}}{\omega_3 + K_{\omega 3} \phi(t)}$$

2.20.2 JFET Parameter Symbols

The symbols used by NET-2 to represent the JFET device parameters are given in Table 2-11. The user may control and reference any quantity for which a NET symbol has been assigned. Certain indicated parameters are not required by NET unless radiation effects behavior is being calculated. Only numerical constants may be used for parameter values.

Reference to a device parameter within the LIBRARY Entry is accomplished by simply using the symbolic parameter name. References in all other entries are made using the symbolic name JFETn.x where x is the parameter name.

Table 2-11

JFET Symbols (Model 6)

Equation Symbol	Name	NET Symbol	NET Units	Default Value	Comments
A ₁	Channel on conductance parameter	A1	v ⁻¹	0.4	
A ₂	Channel on conductance parameter	A2	v ⁻²	0	
C _{ds}	Drain-source capacitance	CDS	pf	5	
C _{gdo}	Gate-drain transition capacitance parameter	CGDO	pf	5	
C _{gso}	Gate-source transition capacitance parameter	CGSO	pf	5	
G ₁	Saturation current parameter	GLI	ma	5	Inverted operation
G ₁	Saturation current parameter	GLN	ma	5	Normal operation
G ₂	Saturation current parameter	G2I	mmhos	2	Inverted operation
G ₂	Saturation current parameter	G2N	mmhos	2	Normal operation
G ₃	Saturation current parameter	G3I	ma-v ⁻²	0.2	Inverted operation
G ₃	Saturation current parameter	G3N	ma-v ⁻²	0.2	Normal operation
G _{cc}	Channel on conductance at V _{gs} = V _{rc} , V _{ds} = 0	GCC	mmhos	2	
I _{gdo}	Gate-drain junction saturation current	IGDO	ma	1E-9	IGDO > 0
I _{gso}	Gate-source junction saturation current	IGSO	ma	1E-9	IGSO > 0
I _{p21}	Photocurrent constant	IP21	pc/pj	0	Reqd for rad effects only
I _{p22}	Photocurrent constant	IP22	ma \sqrt{ns} /pj	0	Reqd for rad effects only
I _{p31}	Photocurrent constant	IP31	pc/pj	0	Reqd for rad effects only
I _{p32}	Photocurrent constant	IP32	ma \sqrt{ns} /pj	0	Reqd for rad effects only
K _G	Channel conductance damage constant	KG	neut ⁻¹	0	Reqd for rad effects only
K _{Ids}	Saturation current damage constant	KIDS	neut ⁻¹	0	Reqd for rad effects only
K _{Igd}	Saturation current damage constant	KIGD	neut ⁻¹	0	Reqd for rad effects only
K _{Igs}	Saturation current damage constant	KIGS	neut ⁻¹	0	Reqd for rad effects only

Table 2-11
(Continued)

Equation Symbol	Name	NET Symbol	NET Units	Default Value	Comments
K_{w2}	Diffusion capacitance damage constant	KW2	neut ⁻¹	0	Reqd for rad effects only
K_{w3}	Diffusion capacitance damage constant	KW3	neut ⁻¹	0	Reqd for rad effects only
N_{gd}	Gate-drain transition capacitance parameter	NGD	none	0.3	
N_{gs}	Gate-source transition capacitance parameter	NGS	none	0.3	
none	Polarity parameter	S	none	1	+1 for n channel, -1 for p channel
S_1	Saturation conductance parameter	S1	empirical	1E-4	
S_2	Saturation conductance parameter	S2	empirical	0	
S_3	Saturation conductance parameter	S3	empirical	0	
T	Lifetime of minority carriers	T	ns	0	Reqd for rad effects only $T > 0$
θ_2	Gate-drain junction emission constant	TH2	v ⁻¹	30	
θ_3	Gate-source junction emission constant	TH3	v ⁻¹	30	
Vdst	Saturation voltage parameter	VDSI	v	5	Inverted operation
Vdst	Saturation voltage parameter	VDSN	v	5	Normal operation
V_k	V_{sat} parameter	VK1	none	1	Inverted operation
V_k	V_{sat} parameter	VKN	none	1	Normal operation
Vp	Pinch off voltage	VPI	v	-5	Inverted operation
Vp	Pinch off voltage	VPN	v	-5	Normal operation
Vrc	V_{gs} voltage for measuring G_{cc}	VRC	v	0	
Vzgd	Gate-drain transition capacitance parameter	VZGD	v	1	VZGD > 0
Vzgs	Gate-source transition capacitance parameter	VZGS	v	1	VZGS > 0
ω_2	Gate-drain diffusion capacitance parameter	W2	ns ⁻¹	0.1	W2 > 0
ω_3	Gate-source diffusion capacitance parameter	W3	ns ⁻¹	0.1	W3 > 0

2.20.3 JFET Data Reduction

The user is referred to Section 9.1.2.1 for a general discussion of the data reduction feature. Specific details for the JFET are given below.

NET-2 contains data reduction capability for obtaining parameters which describe the DC steady state drain-source characteristics in both the normal and inverted mode of operation.

The two types of data reduction available are summarized in Table 2-12. This table lists the data reduction type code, the symbols for the parameter values which are calculated, and the quantities which must be specified for each data reduction type.

drtype	Description	Input Data Sequence	Parameters Calculated
DCN	Normal drain-source DC characteristic	Vgs, Vds, Id, Wgt	G1N, G2N, G3N, VPN, VKN, VDSN, VRC, GCC, S1, S2, S3
DCI	Inverted drain-source DC characteristic	Vgs, Vds, Id, Wgt	G1I, G2I, G3I, VPI, VKI, VDSI

Table 2-12. JFET Data Reduction Types

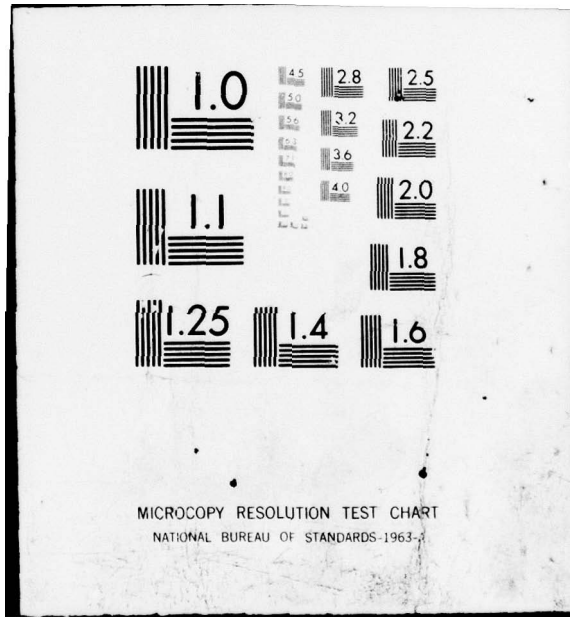

MICROCOPY RESOLUTION TEST CHART
NATIONAL BUREAU OF STANDARDS-1963-A

For the DCN data reduction, the input should be a complete set of first quadrant drain-source characteristic curves for at least three values of V_{gs} . The polarity must be that of an n-channel device as illustrated in Fig. 2-10. It is important that the digitized data be closely spaced about V_{sat} for each curve, unless the user supplies values for VPN and VKN, and fixes them by including them in the fixedparams field.

For the DCI data reduction, the input is a set of third quadrant drain-source characteristic curves. However, the signs of the numerical data must be the same as for an n-channel device operating in the first quadrant such as illustrated in Fig. 2-10. The comments for the DCN data reduction apply to the analogous parameter evaluations in the inverted mode. There is no analysis of data in the "on" region in the DCI data reduction. However, data must be supplied about V_{sat} unless the values of VPI and VKI are supplied by the user.

The parameters VKI, VKN, VPI, VPN, VDSI, VDSN, and VRC may be fixed, either singly or in combination.

The JFET model includes four polynomials specified by the parameters GCC, A1, and A2, the parameters G1N, G2N, and G3N, the parameters G1I, G2I, and G3I, and the parameters S1, S2, and S3. Each of these polynomials is a quadratic in form, composed of a zero order coefficient, a first order coefficient, and a second order coefficient. For each polynomial the following rules apply in regard to fixing parameter values: If the zero order coefficient is fixed, then the calculation for all three coefficients of that polynomial are omitted; if the first order coefficient is fixed, then a value of zero is used for the first and second order coefficients; if the second order coefficient is fixed, then a value of zero is used for the second order coefficient.

All entries in the startparams field are ignored by NET-2.

2.21 Core Winding

The core winding is a circuit element which is magnetically coupled to an associated magnetic core element through a specified number of turns. The format is:

CWn a b MCn N, R

where: CWn = core winding ID
a and b = core winding terminal node names
MCn = magnetic core ID for core linked by winding
N = number of winding turns on magnetic core
R = resistance of winding

The winding resistance must not assume a value of zero. The winding resistance specification is optional; NET-2 will supply .0001 as a default value.

Current flowing through the core windings associated with a particular magnetic core produces a magnetomotive force F on the core. The core undergoes a change in magnetic flux as a result of the application of the magnetomotive force. This change in flux induces a switching signal back into the various core windings. The switching is electrically represented in the core winding by a series impedance and voltage source.

The equivalent circuit for the core winding is shown in Fig. 2-12.

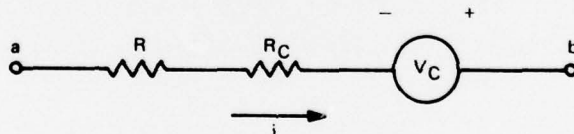

Figure 2-12. Core Winding Equivalent Circuit

The circuit elements R_c and V_c represent the Thevenin equivalent circuit of the magnetic core and are given by:

$$R_c = N^2 \dot{\phi}'$$

$$V_c = N\dot{\phi} - R_c i$$

where: $\dot{\phi} = \frac{d\phi}{dt}$, the time rate of flux change,

ϕ = the flux in the magnetic core linked by the winding due to currents flowing in all windings linking that core,

$\dot{\phi}' = \frac{\partial \dot{\phi}}{\partial F}$, where F is the magnetomotive force producing the flux ϕ ,

N = the number of turns of core winding linking magnetic core,

R = core winding resistance,

i = current through core winding.

Details concerning the derivation of the core winding model may be found in the MTRAC report by Nitzan and Herndon¹⁴.

The voltage v across the core winding is given by

$$v = e_a - e_b$$

where e_a and e_b are the node voltages at nodes a and b , respectively.

The current i flowing through the winding is given by

$$i = \frac{v - V_c}{R + R_c}$$

The power dissipation P is given by

$$P = iv$$

The user may make reference to the number of turns N , the series resistance R , the voltage v across the winding, the current i through the winding, and the power dissipation P of the winding by using the symbolic names CWn , $CWn.l$, $V(CWn)$, $I(CWn)$, and $P(CWn)$, respectively.

2.22 Magnetic Core

NET-2 contains a model for a square loop magnetic core linked with an arbitrary number of windings. The model was developed by Nitzan and is similar to the core model used in the MTRAC program.^{14,15} The core model in NET-2 accepts only $\phi(F)$ curve data, as opposed to the MTRAC model which also accepts $B(H)$ curve data. The magnetic core model is applicable to ferrite cores and to slowly switching tape-wound metallic cores with different $\phi(F)$ characteristics.

The magnetic core model has no electrical terminals. Linkage to the electrical circuit is accomplished through core windings which are associated with a particular magnetic core. The format is:

MCn (p) Type ϕ_0

where: MCn = magnetic core ID

p = optional parallel segment designation (including associated windings)

Type = type name for magnetic core

ϕ_0 = initial remanent magnetization of core, expressed as a signed fraction of the remanent magnetization parameter ϕ_r

The specification of ϕ_0 is optional; NET-2 will supply 0 as a default value.

The magnetic core requires device parameters from the Device Parameter Library. The model number is 9.

The core model accounts for both elastic and inelastic switching components of flux. The total $\dot{\phi}$ is the sum of these two components:

$$\dot{\phi} = \dot{\phi}_\epsilon + \dot{\phi}_i$$

Since $\dot{\phi}' = \frac{\partial \dot{\phi}}{\partial F}$ we must also have

$$\dot{\phi}' = \frac{\partial \dot{\phi}_\epsilon}{\partial F} + \frac{\partial \dot{\phi}_i}{\partial F} = \dot{\phi}'_\epsilon + \dot{\phi}'_i$$

Models for $\dot{\phi}_\epsilon$ and $\dot{\phi}_i$ are described in 2.22.1 and 2.22.2.

2.22.1 Elastic $\dot{\phi}$ Components

The quantity $\dot{\phi}_\epsilon$ is given by

$$\dot{\phi}_\epsilon = \epsilon \dot{F}$$

where

$$\epsilon = p_1 \left[|F| \left(\frac{1}{|F| + p_2} - \frac{1}{|F| + p_3} \right) + \ln \left(\frac{|F| + p_2}{|F| + p_3} \right) \right]$$

$$p_1 = \frac{\phi_s - \phi_r}{(L_o - L_i) H_a}$$

$$p_2 = H_a L_o$$

$$p_3 = H_a L_i$$

The quantity $\dot{\phi}'_\epsilon$ is given by

$$\dot{\phi}'_\epsilon = \frac{\epsilon}{\Delta t} + \epsilon' \dot{F}$$

where

$$\epsilon' = s p_1 \left(\frac{1}{|F| + p_2} - \frac{1}{|F| + p_3} \right) \left[2 - |F| \left(\frac{1}{|F| + p_2} + \frac{1}{|F| + p_3} \right) \right]$$

and $s \equiv \text{sign}(F)$.

The calculation of $\dot{\phi}_\epsilon$ and $\dot{\phi}'_\epsilon$ may be bypassed if desired (2.22.5).

2.22.2 Inelastic $\dot{\phi}$ Components

The quantity $\dot{\phi}_i$ is given by

$$\dot{\phi}_i = s\dot{\phi}_p \left[1 - \left(\frac{2s\phi + \phi_s - \phi_d}{\phi_s + \phi_d} \right)^2 \right]$$

where $s = \text{sign}(F)$.

By differentiating $\dot{\phi}_i$ with respect to F we obtain $\dot{\phi}_i'$ as

$$\dot{\phi}_i' = \left[1 - \left(\frac{2s\phi + \phi_s - \phi_d}{\phi_s + \phi_d} \right)^2 \right] \dot{\phi}_p' + 4\dot{\phi}_p \left[\frac{(2s\phi + \phi_s - \phi_d)(s\phi + \phi_s)}{(\phi_s + \phi_d)^3} \right] \phi_d'$$

where $\dot{\phi}_p' = d\dot{\phi}_p(F)/dF$ and $\phi_d' = d\phi_d(F)/dF$.

Models for ϕ_d , ϕ_d' , $\dot{\phi}_p$, and $\dot{\phi}_p'$ are described in 2.22.3 and 2.22.4

2.22.3 Static $\phi(F)$ Curve Model

The equations which describe in piecewise fashion the $\phi(F)$ curve are presented in this section. First a general model is given, encompassing all regions of the curve. Then, certain portions of the curve are deleted, leading to simplified curves requiring fewer device parameters to describe the curve shape.

2.22.3.1 General $\phi(F)$ Curve

Fig. 2-13(a) illustrates the general $\phi(F)$ curve shape, representing the quantity ϕ_d as a function of magnetomotive force F . The curve consists of six regions.

Regions 1, 4, and 5 describe $\phi_d(F)$ of ferrite cores with no ϕ_d jump at the threshold $F = F_{d1}$. Regions 2 and 3 extend the ϕ_d behavior to ferrite cores with ϕ_d jumps and to tape-wound metallic cores of various types.

Region 1 is an extension of the region of negative saturation. It is described by the function

$$\phi_d = \frac{\phi_s - \phi_r}{(L_o - L_i)H_a} F \ln \left(\frac{F - H L_o}{F - H L_i} \right) - \phi_r$$

where L_i and L_o are inside and outside circumferential lengths and H_a is a material saturation constant.

Region 2 accounts for a possible curvature in $\phi_d(F)$, such as may be found in tape-wound cores. This curvature is described by a four-parameter function of the form $p_5 + p_6(F - F_{d1}) + p_8(F - F_{d1})^{p_7}$ which satisfies the following requirements: It is tangent to $\phi_d(F)$ of Region 1 at the point (F_{d1}, ϕ_{d1}) , thus fixing p_5 and p_6 , and it passes through the points (F_{d2}, ϕ_{d2}) and $[F_{dz}, 1/2(\phi_{d1} + \phi_{d2})]$, where $1/2(F_{d1} + F_{d2}) \leq F_{dz} \leq F_{d2}$, thus fixing p_7 and p_8 . Note that F_{dz} affects the curvature of $\phi_d(F)$ and that if $F_{dz} = 1/2(F_{d1} + F_{d2})$, then $\phi_d(F)$ becomes a straight line connecting the points (F_{d1}, ϕ_{d1}) and (F_{d2}, ϕ_{d2}) . Region 2 may, alternatively, be used to approximate a jump in $\phi_d(F)$ at $F = F_{d1}$ by a monotonically increasing $\phi_d(F)$ (usually, a straight line of a high slope) in order to prevent computational oscillations.

Region 3 is a straight line between the points (F_{d2}, ϕ_{d2}) and (F_{d3}, ϕ_{d3}) . This region is included because a large portion of the static $\phi(F)$ curve of a tape-wound core, whose static $B(H)$ loop is square, is linear. The larger the ratio OD/ID of the core, the lower the slope of Region 3.

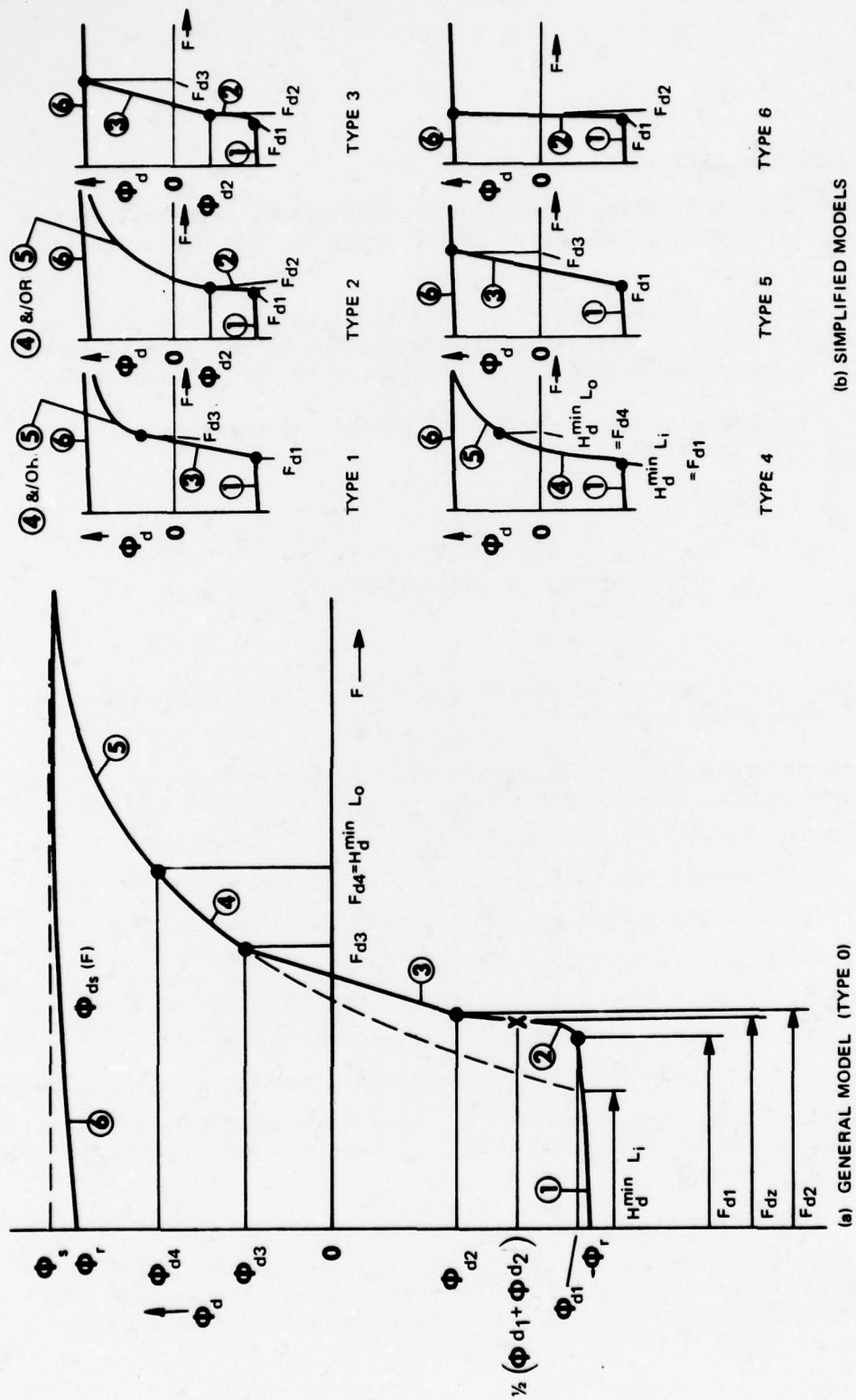

Figure 2-13. Static $\phi(F)$ Curve Models

Regions 4 and 5 (or Region 5 alone) describe the nonlinear portion of $\phi_d(F)$ from nonsaturation to saturation. These regions cover most of the static $\phi(F)$ curve of a ferrite core. In the case of a tape-wound core, the $\phi_d(F)$ "wing" that approaches saturation is likely to be described by Region 5 alone. Region 4 is described by the function

$$\phi_d = \frac{(\phi_s + \phi_r)H_q}{(L_o - L_i)H_n} \left\{ \frac{F}{H_d^{\min}} - L_i + F \left(\frac{1}{H_n} - \frac{1}{H_q} \right) \ln \left[\frac{F \left(1 - \frac{H_n}{H_d^{\min}} \right)}{F - H_n L_i} \right] \right\} - \phi_r$$

and Region 5 is described by the function

$$\phi_d = \frac{(\phi_s + \phi_r)H_q}{(L_o - L_i)H_n} \left[L_o - L_i + F \left(\frac{1}{H_n} - \frac{1}{H_q} \right) \ln \left(\frac{F - H_n L_o}{F - H_n L_i} \right) \right] - \phi_r$$

in which H_n and H_q are material nonsaturation constants and

$$H_d^{\min} = \frac{1}{4} \left[H_s - \sqrt{H_s^2 - 8 \left(1 + \frac{\phi_r}{\phi_s} \right) H_a H_q} \right]$$

where

$$H_s = H_a + H_q + H_n + \frac{\phi_r}{\phi_s} (H_a + H_q - H_n)$$

Region 6 describes $\phi_d(F)$ in the positive saturation region. It is anti-symmetric to Region 1 if the latter were extended to the region of negative

F. Because of the antisymmetric relation $\phi_d(F) = -\phi_d(-F)$, Region 6 is described by the function

$$\phi_{ds} = \frac{\phi_s - \phi_r}{(L_o - L_i)H_a} F \ln \left(\frac{F + H_a L_o}{F + H_a L_i} \right) + \phi_r$$

where $\phi_{ds}(F)$ denotes $\phi_d(F)$ in Region 6.

The quantity ϕ'_d is given by $\frac{d\phi_d}{dF}$ and is the slope of the $\phi_d(F)$ curve.

2.22.3.2 Simplified $\phi(F)$ Curves

The general curve for $\phi(F)$ described in 2.22.3.1 can frequently be simplified for specific cores, depending upon the material, dimensions, and the temperature of these cores. Assuming that Regions 1 and 6 are nonlinear, six simplified models, referred to as Types 1 through 6, are distinguished in Fig. 2-13(b). Note that no distinction is made between the case of both Regions 4 and 5 and the case of Region 5 alone because the two cases are related. Usually, polycrystalline ferrite cores are characterized by Types 2 and 4, whereas gain-oriented tape-wound cores may exhibit any type.

These simplified curves are obtained by eliminating one or more regions from the general curve as follows:

- Type 1 -- Region 2 is eliminated.
- Type 2 -- Region 3 is eliminated.
- Type 3 -- Regions 4 and 5 are eliminated.
- Type 4 -- Regions 2 and 3 are eliminated.
- Type 5 -- Regions 2, 4, and 5 are eliminated.
- Type 6 -- Regions 3, 4, and 5 are eliminated.

2.22.4 $\dot{\phi}_p(F)$ Curve Model

Fig. 2-14 shows the dependency of $\dot{\phi}_p$ upon F . The equations which describe this curve are:

$$\dot{\phi}_p = \begin{cases} 0 & \text{for } 0 \leq F \leq F_{d1} \\ \lambda_d (F - F_{d1})^{\nu_d} & \text{for } F_{d1} \leq F \leq F_{dB} \\ \lambda (F - F_0)^\nu & \text{for } F_{dB} \leq F \leq F_B \\ \rho_p (F - F_0) & \text{for } F_B \leq F \leq F_{B1} \\ \rho_{p1} (F - F_{01}) & \text{for } F_{B1} \leq F \end{cases}$$

This model includes a linear $\dot{\phi}_p(F)$ region for $F \geq F_{B1}$. This region has been observed with some tape-wound metallic cores. For most cases, however, this additional region is unnecessary and will be avoided automatically by assigning a zero value to F_{B1} .

Differentiation with respect to F of the equations for $\dot{\phi}_p$ lead to a set of equations for $\dot{\phi}'_p$:

$$\dot{\phi}'_p = \begin{cases} 0 & \text{for } 0 \leq F \leq F_{d1} \\ \nu_d \lambda_d (F - F_{d1})^{\nu_d - 1} & \text{for } F_{d1} \leq F \leq F_{dB} \\ \nu \lambda (F - F_0)^{\nu - 1} & \text{for } F_{dB} \leq F \leq F_B \\ \rho_p & \text{for } F_B \leq F \leq F_{B1} \\ \rho_{p1} & \text{for } F_{B1} \leq F \end{cases}$$

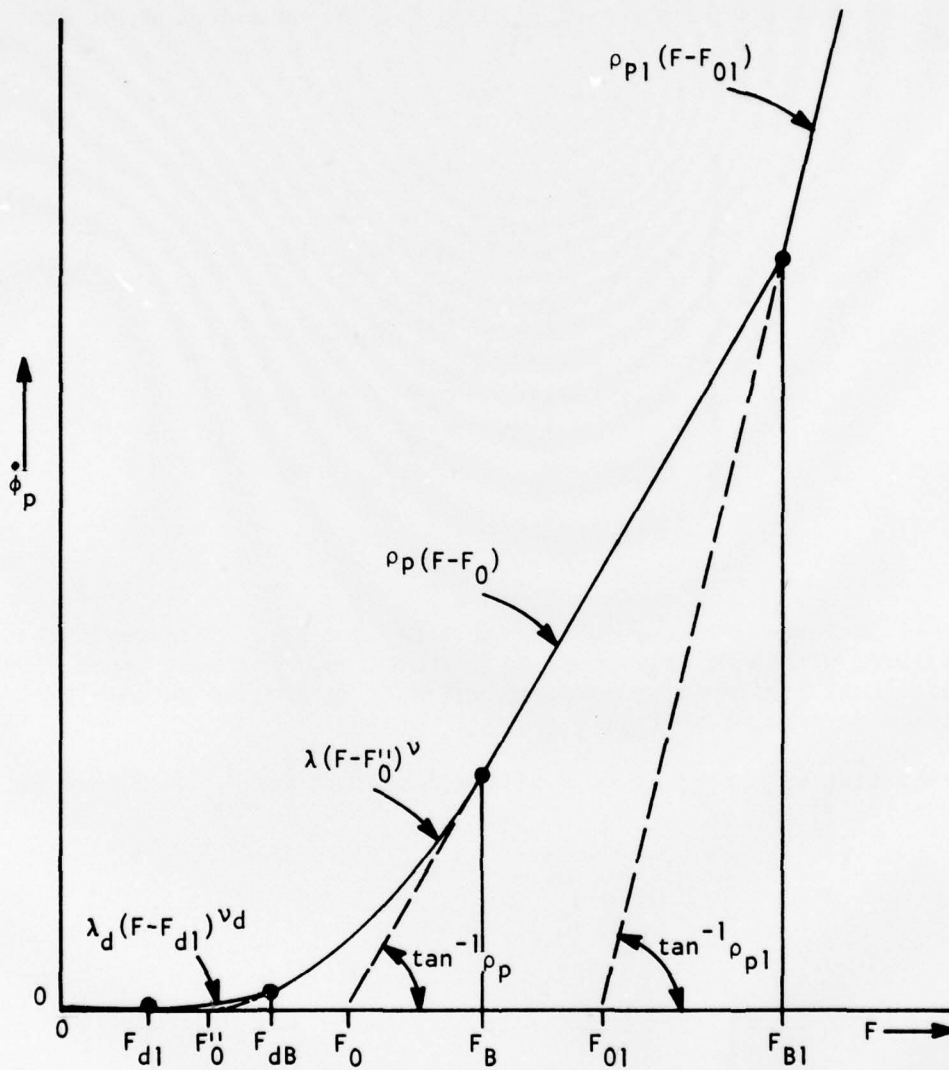

Figure 2-14. $\dot{\phi}_p(F)$ Curve Model

Nine parameters (λ_d , ν_d , F_{dB} , F_0'' , λ , ν , F_B , F_0 , and ρ_p) define the first four regions of the $\dot{\phi}_p(F)$ curve. However, the values of some of these parameters may be approximated quite closely from the values of the remaining parameters.

For continuity, the expressions for $\dot{\phi}_p(F)$ and $d\dot{\phi}_p(F)/dF$ of neighboring regions must be equal at the borders $F = F_{dB}$ and $F = F_B$.

$$\nu_d = \nu \frac{F_{dB} - F_{d1}}{F_{dB} - F_0''}$$

$$\lambda_d = \lambda \frac{(\nu/\nu_d)^\nu}{(F_{dB} - F_{d1})^{\nu_d - \nu}}$$

Continuity at $F = F_B$ imposes the relations

$$\nu = \frac{F_B - F_0''}{F_B - F_0}$$

$$\lambda = \frac{\rho_p}{\nu(F_B - F_0'')^{\nu-1}}$$

These relations impose four constraints on the nine parameters required. Hence, only five parameters are needed to completely specify $\dot{\phi}_p$ vs F .

In addition, the parameter F_{dB} can be obtained from the empirical relation

$$F_{dB} \approx 1.15 F_0''$$

Thus, if the values of F_0'' , F_B , F_0 , and ρ_p are known, the remaining parameters required for the $\dot{\phi}_p(F)$ curve may be determined.

2.22.5 Magnetic Core Parameter Data

Since the magnetic core model may be used in several optional forms, it is useful to summarize the parameter subsets which are required for each of the options.

Basically the core model consists of two parts, namely, a model for elastic flux switching and a model for inelastic flux switching. The inelastic model, in turn, is derived from two characteristic curves, $\phi_d(F)$ and $\phi_p(F)$, shown in Figs. 2-13 and 2-14, respectively.

NET permits the user to bypass the elastic model completely for any particular core, if desired. This is done by setting the device parameter $ELAS = 0$. When the elastic switching is bypassed NET sets $\phi_\epsilon = \phi'_\epsilon = 0$.

NET also provides a parameter for each magnetic core to assist in convergence of the currents in the individual core windings which link that core. This parameter, PSTEP, normally has a value of zero, in which case Aitken's formula is used to smooth the core winding currents. An alternate value of unity for PSTEP accomplishes smoothing by a simple averaging technique, based on present and immediate past values of currents.

2.22.5.1 $\phi(F)$ Curve Parameter Data

The $\phi(F)$ curve in its most general form (Type 0) requires the quantities ϕ_s , ϕ_r , F_{d1} , F_{dz} , F_{d2} , F_{d3} , ϕ_{d2} , L_i , L_o , H_a , H_q , and H_n to be specified. However, if Region 2 is linear (with either finite or infinite slope), the quantity $F_{dz} = 0$ is specified. If Region 2 is linear and has an infinite slope (jump), the quantity $F_{d2} = 0$ is specified.

When simplified models are used for $\phi(F)$ curve, certain parameters may be omitted. These are summarized below:

- Type 1 -- Omit F_{dz} , F_{d2} , ϕ_{d2}
- Type 2 -- Omit F_{d3}
- Type 3 -- Omit H_q , H_n
- Type 4 -- Omit F_{d1} , F_{dz} , F_{d2} , F_{d3} , ϕ_{d2}
- Type 5 -- Omit F_{dz} , F_{d2} , ϕ_{d2} , H_q , H_n
- Type 6 -- Omit F_{d3} , ϕ_{d2} , H_q , H_n

In types 0, 2, 3, and 6 the quantities F_{dz} and F_{d2} may or may not be required depending upon whether or not Region 2 is linear and has finite or infinite slope, as described above.

2.22.5.2 $\dot{\phi}_p(F)$ Curve Parameter Data

The $\dot{\phi}_p(F)$ curve in its most general form requires specification of the quantities $\lambda_d, \nu_d, F_{dB}, F_0'', \lambda, \nu, F_B, F_0, \rho_p, F_{B1}, F_{01}, \rho_{p1}$.

If Region 2 is unknown, set $F_{dB} = \lambda_d = \nu_d = 0$ (NET will approximate these as indicated below. If Region 5 ($F_{B1} \leq F$) is absent, set $F_{B1} = 0$ (F_{01} and ρ_{p1} need not be specified).

NET provides default values automatically for certain quantities whose values are entered as zero by the user. The default values are given below:

$$\text{If } \phi_s = 0, \phi_s = 1.1\phi_r$$

$$\text{If } \nu = 0, \nu = \frac{F_B - F_0''}{F_B - F_0}$$

$$\text{If } \lambda = 0, \lambda = \frac{\rho_p}{\nu(F_b - F_0'')^{\nu-1}}$$

$$\text{If } \nu_d = 0, \nu_d = \nu \frac{F_{dB} - F_{d1}}{F_{dB} - F_0''}$$

$$\text{If } \lambda_d = 0, \lambda_d = \lambda \frac{(\nu/\nu_d)^\nu}{(F_{dB} - F_{d1})^{\nu_d-\nu}}$$

$$\text{If } F_{dB} = 0, F_{dB} = 1.15F_0''$$

$$\text{If } F_{dz} < \frac{1}{2}(F_{d1} + F_{d2}), F_{dz} = \frac{1}{2}(F_{d1} + F_{d2})$$

2.22.6 Magnetic Core References

The symbols used by NET-2 to represent the magnetic core parameters are given in Table 2-13. The user may control and reference any quantity for which a NET symbol has been assigned. Only numerical constants may be used for parameter values.

Reference to a device parameter within the LIBRARY Entry is accomplished by simply using the symbolic parameter name. References in all other entries are made using the symbolic name MCn.x where x is the parameter name.

The user may also reference the initial remanent magnetization factor ϕ_0 by using MCn as the symbolic name.

Table 2-13

Magnetic Core Symbols (Model 9)

Equation Symbol	Name	NET Symbol	NET Units	Default Value	Comments
none	Outside diameter	$\emptyset D$	cm	0.4	$L_o = \pi(\emptyset D)$
none	Inside diameter	ID	cm	0.2	$L_i = \pi(ID)$
ϕ_s	Saturation flux	PHIS	nwebers	0	Optional (See 2.22.5.2)
ϕ_r	Maximum remanent flux	PHIR	nwebers	.03	
none	$\phi(F)$ curve option type	TYPE	none	2	Value = 0,1,2,3,4,5, or 6 (See 2.22.3 and 2.22.5.1)
F_{d1}	Threshold mmf	FD1	ma-turns	200	Optional for Type 4 (See 2.22.5.1)
F_{dz}	$\phi(F)$ curve mmf value	FDZ	ma-turns	0	Optional under various conditions (See 2.22.5.1)
F_{d2}	$\phi(F)$ curve mmf value	FD2	ma-turns	0	Optional under various conditions (See 2.22.5.1)
F_{d3}	$\phi(F)$ curve mmf value	FD3	ma-turns	0	Optional for Types 2,4, and 6 (See 2.22.5.1)
ϕ_{d2}	$\phi(F)$ curve flux value	PHID2	nwebers	-.01	Optional for Types 1,4,5, and 6 (See 2.22.5.1)
H_a	Material saturation parameter	HA	ma-turns/cm	1000	
H_q	Material nonsaturation parameter	HQ	ma-turns/cm	200	Optional for Types 3,5, and 6 (See 2.22.5.1)
H_n	Material nonsaturation parameter	HN	ma-turns/cm	100	Optional for Types 3,5, and 6 (See 2.22.5.1)
λ_d	$\phi_p(F)$ curve parameter	LMDAD	empirical	0	Optional (See 2.22.5.2)
ν_d	$\phi_p(F)$ curve parameter	NUD	empirical	0	Optional (See 2.22.5.2)
F_{dB}	$\phi(F)$ curve mmf value	FDB	ma-turns	0	Optional (See 2.22.5.2)

Table 2-13
(Continued)

Equation Symbol	Name	NET Symbol	NET Units	Default Value	Comments
F_0''	ϕ_p (F) curve mmf value	FOPP	ma-turns	300	
λ	ϕ_p (F) curve parameter	LAMDA	empirical	0	Optional (See 2.22.5.2)
ν	ϕ_p (F) curve parameter	NU	empirical	0	Optional (See 2.22.5.2)
F_b	ϕ_p (F) curve mmf value	FB	ma-turns	1000	
F_0	ϕ_p (F) curve intercept mmf value	FO	ma-turns	500	
ρ_p	ϕ_p (F) curve parameter	RØP	empirical	1	
F_{B1}	ϕ_p (F) curve mmf value	FB1	ma-turns	0	Optional (See 2.22.5.2)
F_{O1}	ϕ_p (F) curve intercept mmf value	F01	ma-turns	0	Optional (See 2.22.5.2)
none	Elastic calculation bypass parameter	ELAS	none	0	ELAS = 1 for elastic calculation (See 2.22.5)
none	Core winding current smoothing formula selector	PSTEP	none	0	PSTEP = 0 for Aitken formula (See 2.22.5)
ρ_{p1}	ϕ_p (F) curve parameter	RØP1	empirical	0	Optional (See 2.22.5.2)

2.23 Combinance

The combinance is a two terminal Linvill element connected between a carrier node and a circuit node. The carrier node may represent either holes or electrons. The format is:

HCn (p) F J Value

where: HCn = combinance ID
p = optional parallel segment designation
F = circuit node name
J = carrier node name
Value = combinance value

The combinance is represented schematically as shown in Fig. 2-15.

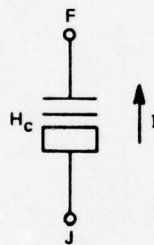

Figure 2-15. Schematic Representation of Combinance

If p_J is the excess carrier density at carrier node J, the conventional current flow I is given as

$$I = H_c p_J$$

The user may reference the combinance value and the combinance current by using the symbolic names HCn and I(HCn), respectively.

2.24 Storance

The storage is a two terminal Linvill element connected between a carrier node and a circuit node. The carrier node may represent either holes or electrons. The format is:

STn (p) F J Value

where: STn = storance ID
p = optional parallel segment designation
F = circuit node name
J = carrier node name
Value = storance value

The storance is represented schematically as shown in Fig. 2-16.

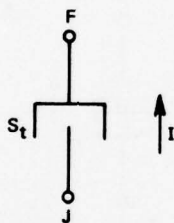

Figure 2-16. Schematic Representation of Storance

If p_J is the excess carrier density at carrier node J, the conventional current flow I is given as

$$I = S_t \frac{dp_J}{dt}$$

The user may reference the storance value and the storance current by using the symbolic names STn and $I(STn)$, respectively.

2.25 Diffusance

The diffusance is a two terminal Linvill element connected between two carrier nodes. The carrier nodes may represent either holes or electrons, and in general each node will represent a different excess carrier density in the same type of material. The format is:

HDn (p) J K Value

where: HDn = diffusance ID
p = optional parallel segment designation
J = carrier node name
K = carrier node name
Value = diffusance value

The diffusance is represented schematically as shown in Fig. 2-17.

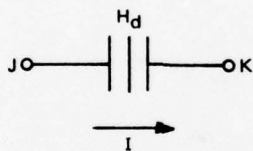

Figure 2-17. Schematic Representation of Diffusance

If p_J and p_K are the excess carrier densities at carrier nodes J and K, respectively, the conventional current flow I is given as

$$I = H_d(p_J - p_K)$$

The user may reference the diffusance value and the diffusance current by using the symbolic names HDn and I(HDn), respectively.

2.26 Driftance

The driftance is a two terminal Linvill element connected between two carrier nodes. The carrier nodes may represent either holes or electrons, and in general each node will represent a different excess carrier density in the same type of material. The format is

DFn (p) J K Value

where: DFn = driftance ID
p = optional parallel segment designation
J = carrier node name
K = carrier node name
Value = driftance value

The driftance is represented schematically as shown in Fig. 2-18.

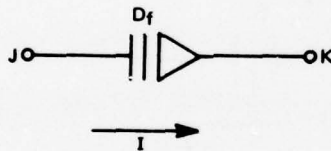

Figure 2-18. Schematic Representation of Driftance

If p_J and p_K are the excess carrier densities at carrier nodes J and K respectively, the conventional current flow I is given by

$$I = D_f(p_J + p_K)$$

The user may reference the driftance value and the driftance current by using the symbolic names DFn and I(DFn), respectively.

2.27 Linvill pn Junction

The Linvill pn junction is a modeled device consisting of two circuit nodes and two carrier nodes. A nonlinear depletion capacitance is connected across the circuit nodes, and a nonlinear expression relates carrier densities at the two carrier nodes to the voltage between the circuit nodes.

The Linvill pn junction is a modeled device and requires device parameters from the Device Parameter Library. The model number is 8.

The format for the pn junction is:

PNn (p) F G J K Type

where: PNn = pn junction ID
p = optional parallel segment designation
F = circuit node in p material
G = circuit node in n material
J = carrier node in p material
K = carrier node in n material
Type = pn junction type name

The equivalent circuit for the Linvill pn junction is shown in Fig. 2-19.

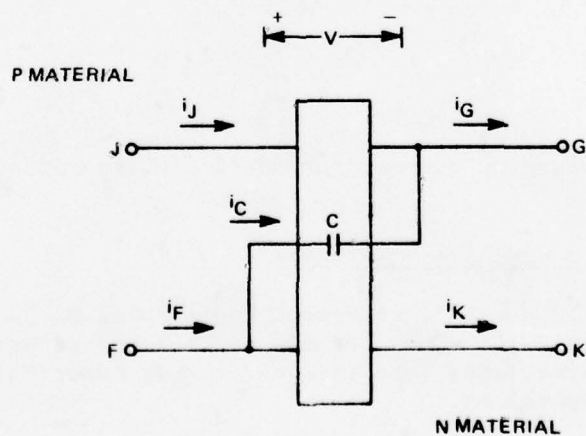

Figure 2-19. Schematic Representation of Linvill pn Junction

Associated with carrier node J is an excess electron density n_J which is given by

$$n_J = -n_{pc} (e^{\theta v} - 1)$$

where v is the junction voltage.

Similarly, there is associated with carrier node K an excess hole density p_K which is given by

$$p_K = p_{no} (e^{\theta v} - 1)$$

The quantities n_J and p_K are represented in the calculation as the node voltages at nodes J and K, respectively.

The depletion capacitance C is given by

$$C = C_o \left(1 - \min \left(\frac{v}{V_z}, .9 \right) \right)^{-N}$$

Kirchhoff's current law is observed through the following relations

$$i_K = i_F - i_C$$

$$i_G = i_J + i_C$$

where i_C is the charging current for the depletion capacitance.

2.27.1 Linvill pn Junction References

The symbols used by NET-2 to represent the Linvill pn junction parameters are given in Table 2-14. The user may control and reference any quantity for which a NET symbol has been assigned. Only numerical constants may be used for parameter values.

References to a device parameter within the LIBRARY Entry is accomplished by simply using the symbolic parameter name. References in all other entries are made using the symbolic name PNN.x where x is the parameter name.

Table 2-14
 Linvill pn Junction Symbols (Model 8)

Equation Symbol	Name	NET Symbol	NET Units	Default Value	Comments
C_o	Depletion capacitance parameter	C	pf	5	
N	Grading constant	N	empirical	0.3	
n_{po}	Equilibrium electron density in p material	NPO	pc/cm ³	1000	
p_{no}	Equilibrium hole density in n material	PNO	pc/cm ³	1000	
θ	Emission constant	TH	v ⁻¹	30	
V_z	Contact potential	VZ	v	1	VZ > 0

2.28 Current Controlled Nodal Variable

NET-2 contains a special element which sets the nodal voltage at a specified node r equal to the current flowing in a resistance inserted into the network. The format is:

CCNVn (p) a b r R

where: CCNVn = element ID
p = optional parallel segment designation
a and b = node names for connecting resistance
r = node name for nodal variable
R = resistance value

The node voltage e_r at node r is given by

$$e_r = \frac{e_a - e_b}{R}$$

where e_a and e_b are the node voltages at nodes a and b, respectively.

The resistance R must not assume a value of zero. The resistance is completely specified by this element format and the user is not required to include a separate resistor entry to describe the resistance.

The user may reference the resistance value and the nodal variable by using the symbolic names CCNVn and N(r), respectively.

3. SYSTEM ELEMENTS

This chapter describes the system elements available in NET-2. For each system element information is included on the element description format, the function performed by the element, and symbolic names for all parameters which may be associated with the element. The element parameters may be designated by numerical constants or mathematical expressions. Multiple values must always be separated by commas.

Unless otherwise noted, there are no computational delays associated with the system elements when their parameter values are specified by numerical constants.

3.1 SUM Element

The SUM element forms the algebraic sum of quantities appearing at the input nodes. There may be as many input nodes as desired. Each input node name may be prefixed with a minus sign to indicate that the negative of the quantity at that node is to be used in the algebraic sum. The format is:

SUMn ØUT IN1 IN2

where: SUMn = element ID

ØUT = output node name

IN1, IN2, etc. = input node names (a minus sign may prefix the node name to indicate subtraction).

An example of the use of this element is

SUM35 A 34 -G3 57 -2

In this example the sum appears at node A and is formed by adding the quantities at nodes 34 and 57 and subtracting the quantities at nodes G3 and 2.

3.2 GAIN Element

The GAIN element multiplies the quantity at the input node by a factor K to form the output quantity. The format is:

GAINn IN ØUT K

where: GAINn = element ID
IN = input node name
ØUT = output node name
K = gain value

The user may reference the value of K by using GAINn as the symbolic name.

3.3 MULT Element

The MULT element forms the product (including quotients) of quantities appearing at the input nodes. There may be as many input nodes as desired. The format is:

MULTn ØUT IN1 IN2

where: MULTn = element ID
ØUT = output node name
IN1, IN2, etc. = input node names

Any input node name may be prefixed with a minus sign to indicate that division by the quantity appearing at that node is desired instead of multiplication. Division by zero value is prohibited.

An example of the use of this element is

MULT46 J -5 98 25 -67

The output quantity which appears at node J is formed by the product of the quantities at nodes 98 and 25 divided by the product of the quantities at nodes 5 and 67.

3.4 Sqrt Element

The Sqrt element delivers a quantity at the output node which is the positive square root of the quantity at the input node. The format is:

SQRtn IN ØUT

where: SQRtn = element ID
IN = input node name
ØUT = output node name

Care must be taken to avoid a negative quantity at the input node.

3.5 ABS Element

The ABS element delivers a quantity at the output node which is the absolute value of the quantity at the input node. The format is:

ABSn IN ØUT

where: ABSn = element ID
IN = input node name
ØUT = output node name

3.6 SIGN Element

The SIGN element delivers a quantity at the output node which is formed by combining the magnitude of the quantity at the first input node with the sign of the quantity at the second input node. The format is:

SIGNn IN1 IN2 ØUT

where: SIGNn = element ID
IN1 = input node name for magnitude quantity
IN2 = input node name for sign quantity
ØUT = output node name

3.7 MAX Element

The MAX element delivers a quantity at the output node which is the algebraic maximum of the quantities which appear at the input nodes. There may be as many input nodes as desired. The format is:

MAXn ØUT IN1 IN2 IN3

where: MAXn = element ID
ØUT = output node name
IN1, IN2, IN3, etc. = input node names

3.8 MIN Element

The MIN element delivers a quantity at the output node which is the algebraic minimum of the quantities which appear at the input nodes. There may be as many input nodes as desired. The format is:

MINn ØUT IN1 IN2 IN3

where: MINn = element ID
ØUT = output node name
IN1, IN2, IN3, etc. = input node names

3.9 TABF Element

The TABF element delivers a quantity at the output node which is an empirical function of one or two input node quantities. The empirical functional relationship is defined by a one- or two-dimensional table, using the input node quantities as arguments for the table lookup. There are two formats, depending upon whether a one- or two-dimensional table is involved:

TABFn TABLEm ØUT IN
TABFn TABLEm ØUT IN1 IN2

where: TABFn = element ID
TABLEm = table ID
ØUT = output node name
IN = input node name for a one-dimensional table
IN1 and IN2 = input node names for the first and second arguments, respectively, for a two-dimensional table

3.10 INT Element

The INT element delivers a quantity at the output node which is the time integral of the quantity at the input node. The format is:

INTn IN ØUT K, Initial

where: INTn = element ID
IN = input node name
ØUT = output node name
K = value of the integrator gain factor
Initial = initial value of the integrator output at zero time

The initial value specification is optional. If it is omitted a default value of zero will be used.

The function performed by this element can be expressed mathematically as

$$e_o(t) = \int_0^t K e_i(t) dt + e_o(0)$$

where $e_o(t)$ is the output nodal quantity, $e_i(t)$ is the input nodal quantity, t is the time variable, K is the integrator gain factor, and $e_o(0)$ is the initial value of the integrator output at zero time. This function is represented as K/s in the AC small signal calculation.

The user may reference the integrator gain factor K and the initial value by using the symbolic names INTn and INTn.1, respectively.

3.11 DERIV Element

The DERIV element delivers a quantity at the output node which is the time derivative of the quantity at the input node. The format is:

DERIVn IN ØUT

where: DERIVn = element ID
IN = input node name
ØUT = output node name

The DERIV element is represented by the transfer function s in the AC small signal calculation.

3.12 Transfer Functions in the s-plane

NET-2 has a group of system elements which accomplish the basic s-plane transfer function operations. Each element has an input and output node and one or more values to represent the quantities in the transfer function.

In each of the elements the quantity at the output node is equal to the appropriate transfer function operating on the input node quantity.

In the formats given below, IN is the input node name, ØUT is the output node name, and a, b, c, and d are values in the transfer function expression.

The transfer function $1/(s+a)$ is available through the format

XFPn IN ØUT a

The transfer function $(s+a)/(s+b)$ is available through the format

XFZPn IN ØUT a, b

The transfer function $s/(s+a)$ is available through the format

XFSPn IN ØUT a

The transfer function $1/(s^2+as+b)$ is available through the format

XFCPn IN ØUT a, b

The transfer function $(s+a)/(s^2+bs+c)$ is available through the format

XFZCPn IN ØUT a, b, c

The transfer function $(s^2+as+b)/((s+c)(s+d))$ is available through the format

XFCZDPn IN ØUT a, b, c, d

The transfer function $(s^2+as+b)/(s^2+cs+d)$ is available through the format

XFCZCPn IN ØUT a, b, c, d

The user may reference the values of a, b, c, and d where they are applicable by symbolic names of the form XXXn, XXXn.1, XXXn.2, and XXXn.3, respectively, where XXX is the appropriate transfer function element prefix. For example, the value of c in element XFCZDP35 is referenced by XFCZDP35.2.

3.13 LOG Element

The LOG element delivers a quantity at the output node which is the natural logarithm of the quantity at the input node. The format is:

LOGn IN OUT

where: LOGn = element ID
IN = input node name
OUT = output node name

Care must be taken to avoid a negative or zero quantity at the input node.

3.14 EXP Element

The EXP element delivers a quantity at the output node which is the exponential function of the quantity at the input node. The format is:

EXPn IN OUT

where: EXPn = element ID
IN = input node name
OUT = output node name

3.15 EXPN Element

The EXPN element delivers a quantity at the output node which is the quantity at the first input node raised to a power given by the quantity at the second input node. The format is:

EXPNn IN1 IN2 OUT

where: EXPNn = element ID
IN1 = node name for first input node
IN2 = node name for second input node (the exponent node)
OUT = output node name

The function performed by this element can be expressed mathematically as

$$e_o = e_1^{e_2}$$

where e_o is the output nodal quantity, e_1 is the nodal quantity at the first input node, and e_2 is the nodal quantity at the second input node.

This element is restricted to non-negative values of e_1 , even though the exponentiation process is defined for negative e_1 when e_2 assumes integer values.

3.16 SINCØS Element

The SINCØS element generates the sine and cosine functions of an input quantity. The format is:

SINCØSn IN SIN CØS

where: SINCØSn = element ID
IN = input node name
SIN = output node name for sine function
CØS = output node name for cosine function

The input quantity is expressed in radians. Either or both output nodes may be used for connection to other parts of the network. Node names must be assigned to both output nodes even though only one is used.

3.17 ASIN Element

The ASIN element delivers a quantity at the output node which is the inverse sine function of the quantity at the input node. The format is:

ASINn IN ØUT

where: ASINn = element ID
IN = input node name
ØUT = output node name

The output quantity is expressed in radians. The input quantity e_i must be in the range $-1 \leq e_i \leq +1$, and the output quantity e_o is constrained to the range $-\pi/2 \leq e_o \leq \pi/2$.

3.18 ACØS Element

The ACØS element delivers a quantity at the output node which is the inverse cosine function of the quantity at the input node. The format is:

ACØSn IN ØUT

where: ACØSn = element ID
IN = input node name
ØUT = output node name

The output quantity is expressed in radians. The input quantity e_i must be in the range $-1 \leq e_i \leq +1$, and the output quantity e_o is constrained to the range $0 \leq e_o \leq \pi$.

3.19 ATAN Element

The ATAN element delivers a quantity at the output node which is the inverse tangent function of the quantity at the input node. The format is:

ATANn IN ØUT

where: ATANn = element ID
IN = input node name
ØUT = output node name

The output quantity e_o is expressed in radians and is constrained to the range $-\pi/2 \leq \pi/2$.

3.20 TANH Element

The TANH element delivers a quantity at the output node which is the hyperbolic tangent of the quantity at the input node. The format is:

TANHn IN ØUT

where: TANHn = element ID
IN = input node name
ØUT = output node name

The input quantity is expressed in radians.

3.21 LIM Element

The LIM element performs symmetric limiting on the input node quantity and delivers the result to the output node. The format is:

LIMn IN ØUT Limit

where: LIMn = element ID
IN = input node name
ØUT = output node name
Limit = value of the upper (positive) limit

The LIM element clips the input quantity at the positive and negative limits. If the input quantity is between the limits, the output quantity is equal to the input quantity.

The user may reference the limit value by using LIMn as the symbolic name.

3.22 LIMINT Element

The LIMINT element performs the function of limit integration of the quantity at the input node and delivers the result to the output node. The LIMINT output quantity is the time integral of the input quantity provided that the magnitude of the output quantity does not exceed a specified limit value. If the limit value is reached and integration of the input quantity is such as to try to increase the output quantity magnitude, the output quantity is held at the appropriate limit value. However, if the output is at a limit value and the input is such as to try to decrease the magnitude of the output, the output will immediately decrease in magnitude and normal integration will resume. The format is:

LIMINTn IN ØUT K, Limit, Initial

where: LIMINTn = element ID
IN = input node name
ØUT = output node name
K = value of integrator gain factor
Limit = value of the upper (positive) limit
Initial = initial value of the integrator output at zero time

The initial value specification is optional. If it is omitted a default value of zero will be used.

The function performed by this element in the absence of limiting can be expressed mathematically as

$$e_o(t) = \int_0^t K e_i(t) dt + e_o(0)$$

where $e_o(t)$ is the output nodal quantity, $e_i(t)$ is the input nodal quantity, t is the time variable, K is the integrator gain factor, and $e_o(0)$ is the initial value of the integrator output at zero time. This function is represented as K/s in the AC small signal calculation.

The user may reference the integrator gain factor K , the limit value, and the initial value by using the symbolic names LIMINTn, LIMINTn.1, and LIMINTn.2, respectively.

3.23 RNGEN Element

The RNGEN element generates random values at its output node. It does not have an input node. The format is:

RNGENn ØUT Type

where: RNGENn = element ID

ØUT = output node name

Type = integer value specifying random number distribution type

If Type = 0 the random numbers are uniformly distributed between 0 and 1. If Type = 1 the random numbers are distributed according to a Gaussian or normal distribution, with a mean value of 0 and a standard deviation of 1.

A new random number is generated for each unique solution point, i.e., for every steady state solution point and for every time step during the transient solution.

The user may reference the value of Type by using RNGENn as a symbolic name.

3.24 NØRM Element

The NØRM element calculates the square root of the sum of the squares of the quantities at the input nodes and delivers the result to the output node. There may be as many input nodes as desired. The format is:

NØRMn ØUT IN1 IN2

where: NØRMn = element ID

ØUT = output node name

IN1, IN2, etc. = input node names

The function performed by this element may be expressed mathematically as

$$e_o = \sqrt{\sum_i e_i^2}$$

where e_o is the output nodal quantity and e_i is the ith input nodal quantity.

3.25 MOD Element

The MOD element performs a modulo reduction on the input nodal quantity and delivers the result to the output node. The format is:

MODn IN ØUT Modulus

where: MODn = element ID
IN = input node name
ØUT = output node name
Modulus = value of the modulus

The input value and the modulus may have any real value. The output value is given by

$$e_o = e_i - [e_i/m]m$$

where e_o is the output value, e_i is the input value, m is the modulus, and $[e_i/m]$ is the greatest signed integer whose value is not greater than e_i/m .

The user may reference the value of the modulus by using MODn as the symbolic name.

3.26 QUANT Element

The QUANT element performs quantization of the input nodal quantity and delivers the result to the output node. The format is:

QUANTn IN ØUT a, b

where: QUANTn = element ID
IN = input node name
ØUT = output node name
a = value of quantization step width
b = value of quantization step height

The mathematical function performed by this element may be expressed as

$$e_o = [e_i/a]b$$

where e_o is output value, e_i is the input value, and $[e_i/a]$ is the greatest signed integer whose value is not greater than e_i/a .

The user may reference the values of a and b by using the symbolic names QUANTn and QUANTn.1, respectively.

3.27 DELAY Element

The DELAY element introduces a time delay between the input node and the output node. The format is:

DELAYn IN ØUT m T

where: DELAYn = element ID
IN = input node name
ØUT = output node name
m = internal buffer size (must be an integer numerical constant)
T = value of time delay

The DELAY element stores successive values of the input nodal quantity and delivers them to the output node after a delay time T has elapsed. The element contains an internal buffer for purposes of storing the delayed information. The internal buffer size m specifies the maximum number of time points which may be stored in the element at any one time. Increasing the buffer size requires additional computer core storage space but does not appreciably alter the computation time.

The user may reference the delay time T using DELAYn as the symbolic name.

3.28 SAMPL Element

The SAMPL element accomplishes the function of sample and hold. It has two input nodes and one output node. The format is:

SAMPLn IN1 IN2 ØUT

where: SAMPLn = element ID
IN1 = node name for input node
IN2 = node name for control node
ØUT = output node name

The output of the SAMPL element is identical to the input whenever the quantity at the control node is greater than zero. If the control node quantity is zero or negative, the output node retains the last value at the input node before the control node became zero or negative. If the control node value is zero or negative during the DC steady state calculation, the output node value is zero.

3.29 HYST Element

The HYST element is used to represent hysteresis effects. It consists of an input and output node and three parameters which define the shape of the major hysteresis loop. The format is:

HYSTn IN ØUT K, a, b

where: HYSTn = element ID
IN = input node name
ØUT = output node name
K = value of slope of side of the hysteresis loop
a = value of the positive intercept on the abscissa
b = value of the positive intercept on the ordinate

The relation between the input and output nodal quantities are illustrated in Fig. 3-1 where the abscissa represents the input and the ordinate represents the output. The hysteresis loop is symmetric about the origin. Minor cycles may be traversed within the loop as shown by the dashed lines in the figure. The magnitude of the output is limited by the value of b.

The user may reference the values of K, a, and b by using the symbolic names HYSTn, HYSTn.1, and HYSTn.2, respectively.

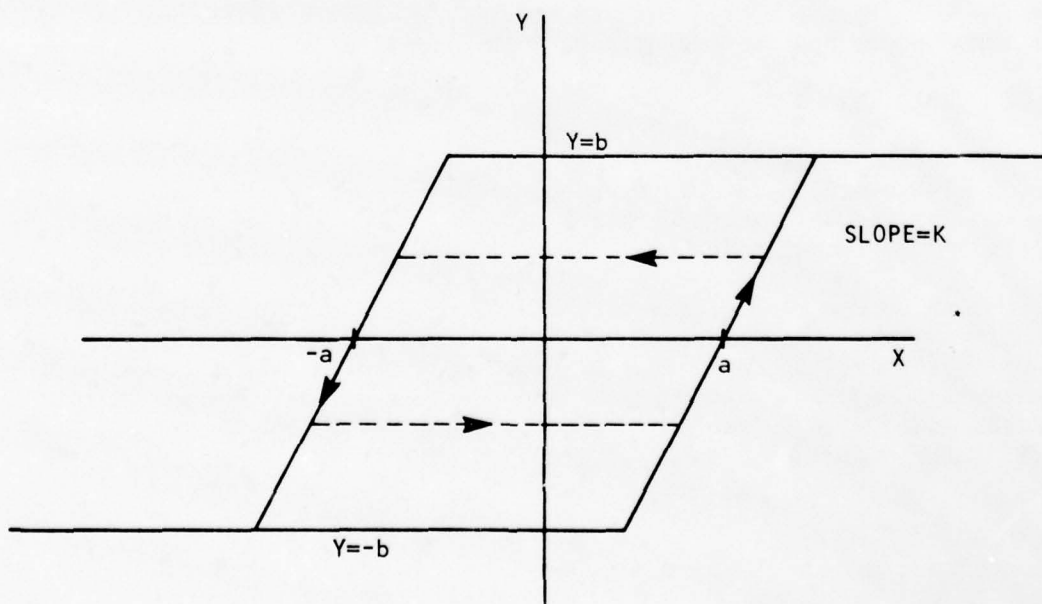

Figure 3-1. Hysteresis Element

3.30 AND Element

The AND element accomplishes the Boolean function of logical AND. It has one output and as many inputs as desired. The format is:

ANDn ØUT IN1 IN2

where: ANDn = element ID
ØUT = output node name
IN1, IN2, etc. = input node names

A maximum of 60 input nodes can be accommodated. Any of the node names (including the output node name) may be prefixed with a minus sign to indicate that the definition of the Boolean values of 0 and 1 are to be interchanged at that node. This permits logical complements to be represented at the input nodes without the need for a separate NOT function, and permits the output to be logically inverted if desired. An example is

AND67 -ØUT 56 -67

which implements the following truth table

<u>56</u>	<u>67</u>	<u>ØUT</u>
0	0	1
0	1	1
1	0	0
1	1	1

Under normal conditions (i.e., no minus sign prefixes on the nodes) a zero or negative value at an input node represents a logical 0, and a value greater than zero at an input node represents a logical 1; a logical 0 at the output node is represented by a value of 0, and a logical 1 at the output node is represented by a value of 1.

3.31 \emptyset R Element

The \emptyset R element accomplishes the Boolean function of logical OR. It has one output and as many inputs as desired. The format is:

\emptyset Rn \emptyset UT IN1 IN2

where: \emptyset Rn = element ID
 \emptyset UT = output node name
IN1, IN2, etc. = input node names

A maximum of 60 input nodes can be accommodated. Any of the node names (including the output node name) may be prefixed with a minus sign to indicate that the definition of the Boolean values of 0 and 1 are to be interchanged at that node. This permits logical complements to be represented at the input nodes without the need for a separate NOT function, and permits the output to be logically inverted if desired. An example is

\emptyset R67 - \emptyset UT 56 -67

which implements the following truth table

<u>56</u>	<u>67</u>	<u>\emptysetUT</u>
0	0	0
0	1	1
1	0	0
1	1	0

Under normal conditions (i.e., no minus sign prefixes on the nodes) a zero or negative value at an input node represents a logical 0, and a value greater than zero at an input node represents a logical 1; a logical 0 at the output node is represented by a value of 0, and a logical 1 at the output node is represented by a value of 1.

3.32 EOR Element

The EOR element accomplishes the Boolean function of Exclusive OR. It has one output and as many inputs as desired. The format is:

EORn ØUT IN1 IN2

where: EORn = element ID
ØUT = output node name
IN1, IN2, etc. = input node names

A maximum of 60 input nodes can be accommodated. Any of the node names (including the output node name) may be prefixed with a minus sign to indicate that the definition of the Boolean values of 0 and 1 are to be interchanged at that node. This permits logical complements to be represented at the input nodes without the need for a separate NOT function, and permits output to be logically inverted if desired. An example is

EOR67 -ØUT 56 -67

which represents the following truth table

<u>56</u>	<u>67</u>	<u>ØUT</u>
0	0	0
0	1	1
1	0	1
1	1	0

Under normal conditions (i.e., no minus sign prefixes on the nodes) a zero or negative value at an input node represents a logical 0, and a value greater than zero at an input node represents a logical 1; a logical 0 at the output node is represented by a value of 0, and a logical 1 at the output node is represented by a value of 1.

3.33 RSTFF Element

The RSTFF element is a logical model of an RST flipflop. The format is:

RSTFFn R S T RESET SET State

where: RSTFFn = element ID
R = reset input node name
S = set input node name
T = trigger input node name
RESET = reset output node name
SET = set output node name
State = initial value of flipflop state

If the value of State is zero or negative, the flipflop is initially in the reset state; if the State value is greater than zero, the flipflop is initially in the set state. The State value is optional. If it is not specified a default value of 0 will be assigned.

When the flipflop is in the reset state, the RESET output will have a value of 1 and the SET output will have a value of 0; when the flipflop is in the set state the RESET output will have a value of 0 and the SET output will have a value of 1.

Values which appear on the R and S inputs are interpreted as follows: if the value is zero or negative, the input value is interpreted as a logical 0; if the value is greater than zero, the input value is interpreted as a logical 1.

If a logical 1 is applied to the R input, the flipflop will assume the reset state, provided that the S input has a logical 0. Similarly, if a logical 1 is applied to the S input, the flipflop will assume the set state, provided that the R input has a logical 0. If neither the R or S input has a logical 1 and the trigger input is quiescent, the flipflop will maintain its previous state. If a logical 1 is applied to both the R and S inputs, both the RESET and SET outputs will have a value of 1. If both the R and S inputs simultaneously return to a logical 0 value, the flipflop will assume the reset state.

If either the R or S inputs have a logical 1 value, the trigger input will have no effect. In the absence of a logical 1 on the set and reset inputs the trigger input will have the following characteristics: If the trigger input value becomes greater than 0.5 the flipflop will reverse its state. The trigger input will have no further effect on the flipflop until the trigger value has decreased to a value of 0.1 or lower, then later becomes greater than 0.5 again, at which time the flipflop will again reverse its state. Thus, the trigger input can be viewed as having a trigger threshold value of 0.5 and a reset value of 0.1, with a requirement that the trigger must be reset before it can be used for triggering purposes again.

If the flipflop state in the DC steady state calculation is inconsistent with the user specified State value, a diagnostic message is provided. The user specified value of State will be ignored in such circumstances.

The user may reference the State value by using RSTFFn as the symbolic name.

3.34 ØUTFL Element

The ØUTFL element provides the user with a means of writing any NET-2 quantity capable of being referenced onto an external file. This element has no nodes. The format is:

ØUTFLn File, S1 S2

where: ØUTFLn = element ID
File = FORTRAN logical unit number for the external file as a numerical integer
S1, S2, etc. = symbolic NET-2 names of quantities whose values are to be written on the external file.

The values of the denoted quantities are written onto the external file along with the value of TIME during the time domain response calculation at every time step. The AC small signal variables at a single frequency may also be included at each time step.

The external file may be read during a subsequent NET-2 run by the INPFL element.

The FORTRAN logical unit number must be chosen so as not to conflict with logical unit numbers utilized for other purposes during the NET-2 run. Logical unit numbers and their assigned function in NET-2 are given in Appendix A. Any logical unit number in Appendix A which is not required by the NET-2 run may be used for the ØUTFL element.

An example of the use of the ØUTFL element is

ØUTFL65 10, R32 GAMDOT X39 I(L27) N(45) L29.1

The ØUTFL entry must not contain any mathematical expressions.

3.35 INPFL Element

The INPFL element provides the user with a means of reading information from an external file for the purpose of driving a NET-2 calculation. The quantities which are stored on the external file appear as nodal quantities in the network. The format is:

```
INPFLn File, IN1 IN2 IN3 .....
```

where: INPFLn = element ID
File = FORTRAN logical unit number for the external file as
a numerical integer
IN1, IN2, IN3, etc. = input node names

The external file must have been written in a format which is compatible with that produced by the \emptyset UTFL element. The number of input nodes must agree with the number of quantities specified in the \emptyset UTFL element description which generated the external file. There is a one-to-one correspondence between the symbolic names in the \emptyset UTFL element which generated the external file and the node names in the associated INPFL element.

As the time domain response is calculated, values of the quantities from the external file will appear in time sequence at the designated nodes. Synchronization of the time variable between the network calculation and the external file is automatically handled. The user need not be concerned with details of time step size. Linear interpolation between values on the external file is used when necessary.

If the external file information is exhausted before termination of the transient calculation, the last set of values in the external file will be utilized until transient termination occurs. If multiple transient solutions are specified, the external file will automatically repeat its set of values for each transient solution.

The FORTRAN logical unit number must be chosen so as not to conflict with logical unit numbers utilized for other purposes during the NET-2 run. Logical unit numbers and their assigned function in NET-2 are given in Appendix A. Any logical unit number in Appendix A which is not required by the NET-2 run may be used for the INPFL element.

An example of the use of the INPFL element which is compatible with the example for the \emptyset UTFL element is

```
INPFL45 11, ASD G45 76 1 34F 5
```

We see that R32 will appear at node ASD, GAMD \emptyset T will appear at node G45, X39 will appear at node 76, I(L27) will appear at node 1, N(45) will appear at node 34F, and L29.1 will appear at node 5.

3.36 SNCLK Element

The SNCLK element is a synchronous clock capable of multiphase operation. The element has only an output node. The format is:

SNCLKn ØUT T, N

where: SNCLKn = element ID
ØUT = output node name
T = value of major time period
N = number of phases

The specification of N is optional. If N is omitted a default value of 2 will be used. The value of N must be a positive integer not less than 2.

During the DC steady state calculation the output value will be N. At the start of the transient solution, the output value will be reset to 1, and will count through the integers up through N, with each successive value appearing for a time interval T/N. At every integral multiple of T the output value restarts at 1 and the counting sequence is repeated.

The user may reference the value of T and N by using SNCLKn and SNCLKn.1 as symbolic names, respectively.

NET-2 chooses its time steps so that they are always coincident with the initiation of successive phases of the clock output.

3.37 DDACC Element

The DDACC element is a digital element which performs the function of an accumulator in a digital differential analyzer. It has two input nodes and three output nodes. It may be used in both synchronous and asynchronous logic applications. The format is:

DDACCn CLK DZ Z CRY RDY Modulus, Δt , Decode, Encode, Zo

where: DDACCn = element ID
CLK = input node name for the clock input
DZ = input node name for the increment quantity Δz
Z = output node name for the modulo sum z
CRY = output node name for the carry c
RDY = output node name for the ready signal
Modulus = value of the accumulator modulus
 Δt = element time delay value
Decode = Value of signal required to activate clock input
Encode = Value of ready output when element is in ready state
Zo = initial value of modulo sum z at time zero

The Decode, Encode, and Z_0 specifications are optional. If they are omitted NET-2 will use default values of 1, 1, and 0, respectively.

The DDACC element produces a modulo sum z and a carry c at time t provided it has been clocked and was in the ready state at time $t - \Delta t$. At time $t - \Delta t$ the applied increment was Δz . The operation can be expressed mathematically as

$$z(t) + mc(t) = z(t-\Delta t) + \Delta z(t-\Delta t)$$

where m is the modulus of the accumulator.

The accumulator has a clock input and a decode value assigned to that input. A transition on the clock input to the decode value from any other value constitutes a clock pulse. If a clock pulse occurs when the ready output is in the ready state, the element is clocked. The element is also clocked if the clock input already is at the decode value and the ready output makes a transition from the not ready state to the ready state.

When the element is in the ready state, the ready output will be set to the encode value. The element is always in the ready condition during the DC steady state calculation. When input clocking occurs, the ready output goes to a zero value, indicating a not ready state, and the quantity Δz at the DZ input node is captured by the element. After a time delay Δt has elapsed, the ready output again assumes the encode value to indicate that the element is ready, and the outputs for the modulo sum z and the carry c appear with their new values reflecting the modulo addition process. These outputs are maintained until a new sum and carry are generated by a subsequent clocking and time delay for the element.

NET-2 chooses its time steps so that they are always coincident with the appearance of the ready condition. This permits the element to be used in asynchronous logic applications.

The user may reference the values of the modulus m , the time delay Δt , the decode value, the encode value, and the initial value Z_0 by using the symbolic names DDACCn, DDACCn.1, DDACCn.2, DDACCn.3 and DDACCn.4, respectively.

3.38 RMS Element

The RMS element calculates the root mean square value of a time series of values of a quantity appearing at the input node. The format is:

RMSn IN ØUT Fo, To

where: RMSn = element ID
IN = input node name
ØUT = output node name
Fo = estimated initial RMS value
To = time interval associated with Fo

The quantities Fo and To are optional. If they are not specified a value of zero will be used.

The quantity $e_o(t)$ at the output node is the root mean square value and is calculated as

$$e_o(t) = \left[\frac{\int_0^t e_i(t)^2 dt + F_o^2 T_o}{t + T_o} \right]^{\frac{1}{2}}$$

where $e_i(t)$ is the quantity appearing at the input node. The RMS value at early times may be influenced appreciably by the estimated value F_o . The estimated value and its associated time interval T_o are included to assist the user in converging to the long term RMS value over a short time interval for periodic or quasi-constant input values. The trapezoidal rule is used for the time integration process.

The user may reference the quantities Fo and To by using the symbolic names RMSn and RMSn.l, respectively.

4. DEFINED SUBNETWORKS

This chapter and Chapter 5 present some conveniences available to the user in describing certain network configurations to NET-2. The casual user of NET-2 may wish to omit these chapters. However, the serious user will wish to take advantage of the flexibility contained in the following pages. The price of this flexibility is a complication in the language.

In developing the material on the following pages, we shall refer to the main network description. By this we mean the network description which is described starting at indentation level 0. The subnetworks which will be defined may become part of the main network or part of some other subnetwork which is also defined.

The naming of nodes and network parameters in defined subnetworks can become quite involved. However, there is a general rule which should be kept in mind: When defining any subnetwork, remember that the subnetwork and any subnetworks nested within it must form a completely specified system and include all necessary definitions of quantities with the exception of tables and functions. All names are written as though the subnetwork were actually the main network.

4.1 DEFINE Entry

The DEFINE Entry is used to define a subnetwork in terms of other network elements known to NET-2. The first line of the entry appears at indentation level 0 and specifies the word DEFINE, the prefix used to designate the subnetwork, and dummy node names which represent terminal nodes in the subnetwork. The prefix may contain only alphabetic characters. Only prefixes which do not already have meaning to NET-2 may be used (see Appendix B for a list of names and prefixes which already have specified meaning to NET-2). Subsequent lines are indented and describe the subnetwork. Subnetwork element descriptions are listed on indentation level 1 according to standard NET-2 formats.

An example of a DEFINE Entry is:

```
DEFINE TR IN ØUT V2 0
      R1 IN 1 10
      C1 IN 1 25
      R2 (2) V2 1 150
      T1 0 1 ØUT 2N645
```

In this example a network element with prefix TR is defined. Network element TR has four dummy terminal nodes: IN, ØUT, V2, and 0. These node names are chosen from the names used in the subnetwork definition in the DEFINE Entry, and the names are treated as distinct from the nodes in the main network to which the subnetwork is connected. Thus, the same names may be used for nodes and network element ID's in both the main network and the defined subnetwork without confusion. Note that all nodes which connect to the main network (including ground) must be included as terminal nodes. System element inputs and outputs are automatically referred to node 0 in the main network.

This defined subnetwork may now be used freely as part of the main network or as part of another defined subnetwork. An example of main network use is:

```
TR35 IN 4 7 0
TR5 (3) 3 16 8 5
```

Note that a numerical suffix is appended to the subnetwork prefix, so that now the subnetwork ID has the appearance of an ordinary network element ID. The connection points are listed in the same order as in the corresponding DEFINE Entry, except that now the node names of the network of which the subnetwork is a part are used. These node names may be the same as or different from the dummy terminal node names in the DEFINE Entry.

Note that the parallel segment designation may be used in both the network element usage in the DEFINE Entry and the defined subnetwork usage.

When a subnetwork is included as part of a larger network or subnetwork, that included subnetwork is said to be nested inside the larger network. Subnetworks may be nested up to a maximum level of sixteen. An example of nesting to a level of four occurs when A, B, C, and D are subnetworks, and the main network contains A (level 1), A contains B (level 2), B contains C (level 3), and C contains D (level 4).

Subnetwork definitions may not be cyclic, as, for example, when A contains B and B contains A.

Figure 4-1 shows the nesting concept in pictorial form. In this illustration, we see subnetworks TQ, SB, HB, and PY have been defined. Their interconnections can be represented by the following excerpt from a complete network description:

```
TQ1 1 3
PY3 3 5 5 6
HB5 2 9
SB3 7 9 9
.....
DEFINE TQ 1 2
        SB2 1 2 7
        .....
DEFINE PY 1 2 3 4
        HB5 2 3
        .....
DEFINE HB 1 2
        .....
DEFINE SB 1 2 3
        HB6 6 3
        .....
```

The dots indicate additional network description which is irrelevant for purposes of this illustration. From this illustration, it is easy to see the nesting concept. We can also see that a defined subnetwork may be used anywhere, but when used it automatically carries all other subnetworks nested inside of it along with it.

We can always refer to a subnetwork nested inside a given subnetwork (or the main network) by composing a compound name constructed of the names of the subnetworks in the order of nesting, starting at the given subnetwork level and proceeding to the desired subnetwork nested inside. For example, the name TQ1.SB2 is a main network reference which refers to subnetwork SB2 which is contained within subnetwork TQ1. The name TQ1.SB2 automatically includes subnetwork TQ1.SB2.HB6 since it is nested inside of TQ1.SB2.

4.2 Referencing Nodes In The Nest

In a given subnetwork definition, it is always possible to refer to nodes which belong to that subnetwork (including the dummy terminal nodes using their dummy names) or to any node in a subnetwork nested inside the subnetwork being defined. All other nodes are inaccessible for reference purposes.

Such a reference is made for purposes of writing a mathematical expression or for interconnecting network elements.

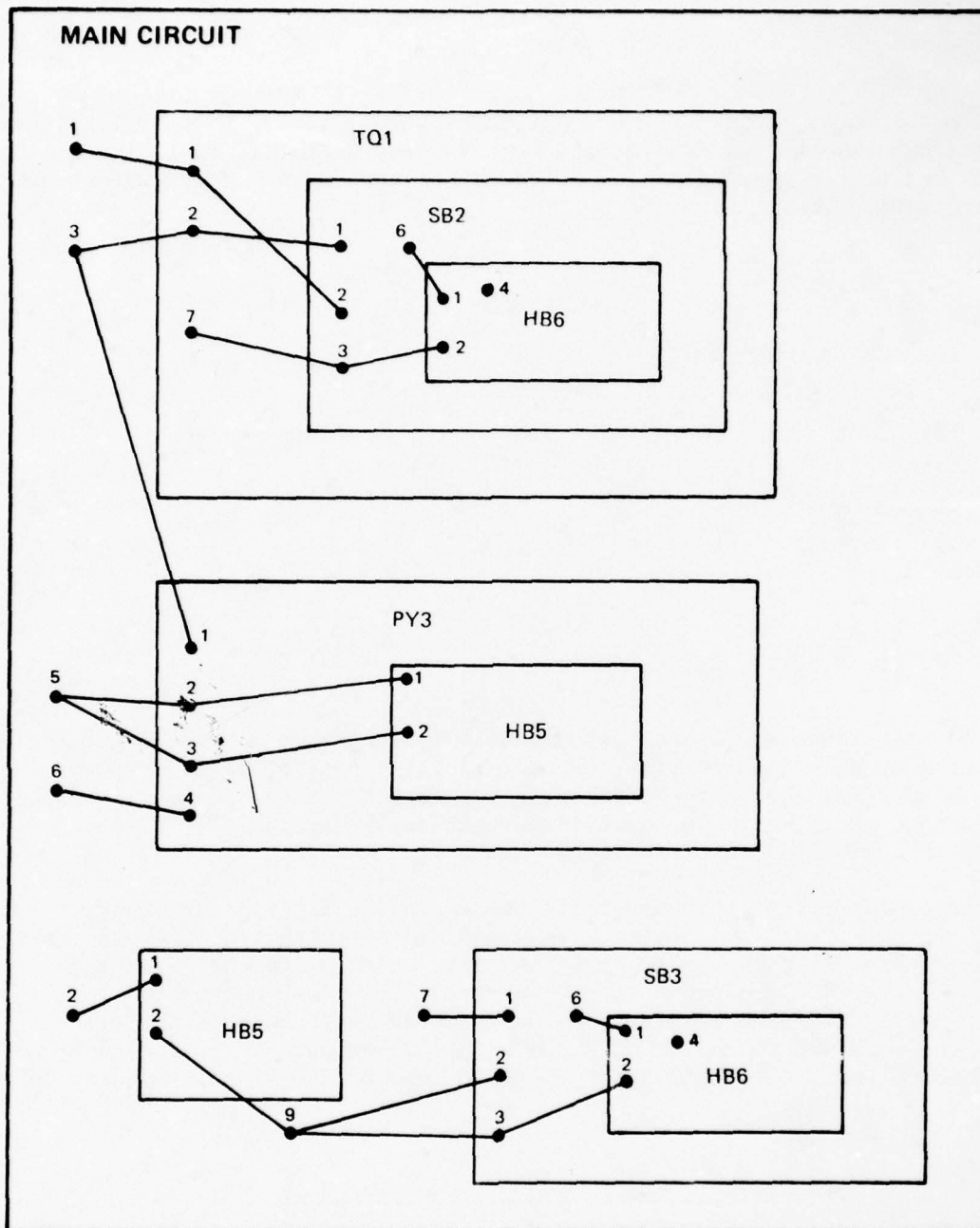

Figure 4-1. Nested Subnetworks

The node name of interest is constructed by starting at the defined subnetwork level and building up a compound name which traces the nesting process. For example, suppose we are defining subnetwork SB and we wish to connect a resistor R23 between node 6 of SB and node 4 of HB6 which is nested within SB (see Fig. 4-1). Then the DEFINE Entry for SB would include the following items:

```
DEFINE SB 1 2 3
        HB6 6 3
        R23 6 HB6.4 39
```

Since the main network can be thought of as the outermost network in the nest, it is seen that in the main network description we can refer to any node. For example, if we wished to insert the same resistor R23 between the indicated nodes, as seen from the main network, we would be forced to use two different resistors since in Fig. 4-1 the network element SB is used twice in the main network. Calling these two resistors R23 and R123, we would then have this equivalent designation in the main network description:

```
R23 TQ1.SB2.6 TQ1.SB2.HB6.4 39
R123 SB3.6 SB3.HB6.4 39
```

In other words, the actual name used to designate the node depends upon where in the network description the reference to that node is being made.

One always has more than one node name available for a subnetwork terminal node when that node is referenced from outside of the subnetwork itself. The user must always refer to the outermost form of the name under such conditions, i.e., he must never use the dummy terminal node name for the subnetwork unless there is no other alternative (there is always an alternative except when the dummy terminal node name referenced is on the same nest level as that from which the reference is being made).

An example using Fig. 4-1 illustrates this point. Let us assume that we wish to define a resistor R5 in subnetwork TQ. This resistor will be connected between node 1 of TQ and node 6 of SB2. We see that we have a choice of node names available for connecting R5, i.e., node names 1 and SB2.2 for one node, and node names SB2.6 and SB2.HB6.1 for the other node. We must always use the node name which is nearest to the referencing nest level. Thus, the legal node names for R5 are 1 and SB2.6 and the use of either of the other two node names is not permissible.

Note that nodes inside of modeled devices can be referred to. For example, if we wish internal node 4 of transistor T4 which is included in the subnetwork TQ1.SB2.HB6, we write TQ1.SB2.HB6.T4.4. In other words, modeled devices are treated like subnetworks for reference purposes.

4.3 Referencing Network Parameters

In a given subnetwork definition, it is always possible to refer to network parameters which have been introduced or defined in that subnetwork or any subnetwork nested inside the subnetwork being defined. All other network parameters are inaccessible for reference purposes. Such a reference is always made for purposes of writing a mathematical expression.

Since the main network can be thought of as the outermost network in the nest, it is seen that in the main network description we can reference any network parameter.

The technique of specifying the correct name for the reference is identical to that used for specifying node names in nested networks. The name is constructed by starting at the defined subnetwork level and building up a compound name which traces the nesting process. This compound name is terminated with the actual name of the quantity of interest.

Let us again use Fig. 4-1 as an illustration. We will introduce a time varying resistor R_6 in the subnetwork definition for SB. In so doing, we must be sure that all quantities used in the mathematical expression for R_6 are defined either in SB or in a subnetwork nested inside SB (with the exception of function and table references which are defined as part of the main network description; see 4.4). We may now refer to this particular R_6 either in the definition of SB or in any subnetwork (including the main network) which contains SB. However, we cannot refer to it in the HB definition since HB is nested inside of SB. Thus, in the main network, we refer to TQ1.SB2. R_6 or to SB3. R_6 , while in the definition of TQ we refer to SB2. R_6 .

4.4 Function and Table Definitions and References

There are special rules which apply to function and table references which may appear in mathematical expressions in a subnetwork definition. The definition of the function or table must be given as a part of the main network description.

An example is:

```
DEFINE LCA A B C
      LC1 A 1 C
      LC2 A B C
      R3 1 C TABLE9(TIME)
TABLE9
  0 0
  1 3
  5 10
DEFINE LC A B C
      L1 A 1 F9(C2)
      C2 B C TABLE7(TIME)
P21 1.68
F9(A) = EXP(A) + 10
LCA1 1 5 7
LCA2 1 3 4
LC1 4 6 3
TABLE7
  3 2
  5 1
  7 0
```

Note that the definitions for TABLE7 and F9 are given as part of the main network description.

Note that there is no modification of the names of functions or tables, such as occurred for nodes and network parameters. However, the arguments may have modified names since they may involve nodes and network parameters.

5. STORED MODELS

The language and rules for defining and using stored models are similar to those for defined subnetworks. Therefore, it is imperative that the details in Chapter 4 be well in hand. Since a knowledge of Chapter 4 is assumed, it will be sufficient only to refer to the principles detailed there in the present discussion.

The models are stored in a library on a permanent storage medium. The capacity of the library is 500 stored models.

5.1 Definition of Models

A stored model may be defined and permanently entered as part of a NET-2 computer run. The model may then be retrieved at any later time by merely referring to it. Since the model may be used in any context, it is important that its definition be completely self-contained.

A stored model is defined by a MØDEL Entry. The first line of the entry appears at indentation level 0 and specifies the word MØDEL, the model prefix, and the dummy terminal node names. The prefix may contain only alphabetic characters and is limited to a maximum of 7 characters. Subsequent lines contain the complete network description, written in exactly the same manner as described in other chapters, only beginning at indentation level 1 instead of indentation level 0. Thus, all indentation levels are increased by one over a normal network description. The DEFINE Entry may be used at will as part of the stored model description, and reference may be made to any other stored model in the library.

An example of a stored model is:

```
MØDEL TR J K L ØUT 0
  LCB1 J 5 0
  LCB2 5 3 0
  C1 3 1 50
  R1 3 1 10
  R2 K 1 100
  T1 0 1 2 2N639
  R3 2 L 2.2
  TG1 2 0 ØUT 0
  F9(A) = A**2*EXP(-ABS(A/50))+35
  DEFINE LCB 1 3 0
    LCA1 1 2 0
    LCA2 2 3 0
  DEFINE LCA A C 0
    C1 B 0 TABLE3(SQRT(TIME))
    C2 C 0 5.67
  TABLE3
    0 20
    5 25
    10 35
    15 36
  L1 A B F9(LCB1.LCA2.C1)
  L2 B C 45.8
```

In this example note that TG1 is specified but not defined. Since the prefix TG has not been defined, NET-2 assumes it is another stored model in the model library. If TG cannot be located in the model library, NET-2 will indicate an error to the user.

If, in the example, the main network description also included a definition of a subcircuit LCA or LCB, no harm would be done. The names used inside the model definition are completely private and will not conflict with any definitions introduced outside of the model definition.

On the other hand, the user has complete freedom to refer to the model from the main network. The model is completely equivalent to a defined subnetwork for this purpose, and can be included as part of the main network or as part of a defined subnetwork nested in the main network or another defined subnetwork. The normal rules for nesting apply and any node or network parameter may be referred to using the normal nesting rules. Thus, if the main network contained network element TR35, then the main network could refer to a specific node or network parameter in the model, e.g., TR35.T1.BN or TR35.LCB2.LCA1.C1.

If the library already contains a model with the same name as that specified in the MØDEL Entry, a warning message will be printed and the original library model will be printed for reference. The new model will then be stored into the library and used.

5.1.1 Restrictions on Function Definitions

The mathematical expression which is used in the definition of a function in a MØDEL Entry must not depend in any way upon particular nodes, response variables, or network parameters, i.e., the mathematical expression must not be written explicitly in terms of any of these quantities. This does not restrict the generality of function definitions in any way since these forbidden quantities may be inserted through the dummy arguments.

Thus, the quantities which may explicitly appear in the mathematical expression for a function definition within a MØDEL Entry are numerical constants, table references, global variables, dummy arguments, and other function references.

These restrictions apply only to function definitions within a MØDEL Entry.

5.2 Using Stored Models

A model being stored or already stored in the library is available for use in a network description as though it were a defined subnetwork. All of the rules regarding defined subnetwork usage apply in this case.

For example, to use model TR in a network involves assigning a numerical suffix to produce a legitimate network element ID and connecting the terminal nodes to the desired nodes in the network:

TR35 (2) 66 76 78 9 0

Note that the parallel segment designation can be used if desired.

If the prefix chosen for a defined subnetwork appearing in the network description is identical with the prefix of a stored model in the library, the defined subnetwork will be used.

6. STATE SOLUTION

There are three types of calculations available in NET-2: State solutions, Monte Carlo solutions, and Optimization solutions. This chapter describes the State solution.

The State solution consists of one or more network response calculations corresponding to a prescribed set of numerical values of network parameters. The nominal network parameter values are used in the calculation except where specifically superseded in a given State solution.

The STATE Entry is used to convey information to the program for State solutions. Within the STATE Entry, there are several types of information statements possible.

Only quantities which have been defined as numerical constants may be changed in the State solution. Thus, it is not possible to alter the forms of tables, functions, or mathematical expressions. However, this restriction does not limit the scope of the State solution in any way. Sufficient flexibility is available in the NET-2 language to permit any situation to be handled.

6.1 STATE Entry

Each State solution is specified by a STATE Entry which consists of two or more lines. The STATE Entry must include an output specification. The first line of any STATE Entry begins at indentation level 0 and has the format:

```
STATEn
```

This line is followed by one or more lines at indentation level 1 which specify output, changes in value of numerical constants, and other information as discussed below.

In referring to various network quantities in a STATE Entry, the same names are used as would be used when referring to these quantities in the main network description.

6.1.1 Network Parameter Value Changes

Network parameter values may be changed by either holding them at a new constant value throughout the State solution or varying them over a specified range in discrete steps during the solution.

6.1.1.1 Constant Values

Each network parameter to be changed to a different constant value is specified by listing its ID and the new value. The new value may be either an actual value or a relative value (suffixed by an asterisk). In the case of relative values, the actual value is the product of the nominal value and the relative value. Examples are:

```
STATE3
  R12 350
  C23 .85*
  D2.TH 1.89
  GT6.FY7.T35.BN .55*
  FREQ 367
```

6.1.1.2 Varying Values

There are two kinds of varying values available. One of them is called the swept variable. Only one quantity may serve as a swept variable.

The other type is the parametric variable. There may be as many parametric variables as desired. The parametric variables are held at a particular value while the swept variable is swept through its range. Then the parametric variables are stepped to their next value and the swept variable is again swept through its range. In this way, a family of curves may be generated through the use of these two types of variables.

An example of a swept variable and two parametric variables is given by:

```
STATE7
  FREQ .005 (25*) 1.5*
  *R12 1 (3) 4 10 (2*) 20 35
  *R34 10 (2) 15 20 50 100 (2) 200
```

Parametric variables are distinguished from swept variables by prefixing them with an asterisk. Thus, in the above example, the swept variable is FREQ and the parametric variables are R12 and R34.

Note that some numbers are enclosed by parentheses while others are not. The numbers which are not enclosed by parentheses represent specific values to be assumed by the variable. If these numbers are suffixed with an asterisk, the relative value is indicated; the actual value is then the product of the nominal value and the relative value.

The number in parentheses indicates a step number, which is the number of steps involved when incrementing from the preceding value to the succeeding value. Normally, linear steps are used; however, if the number in parentheses has an asterisk suffix, logarithmic steps are used. The written number sequence may not begin or end with step numbers, and two step numbers may not occur in succession in the sequence.

When more than one parametric variable is used, the total number of values which will be assumed for each must be the same.

Thus, in the example shown above, R12 assumes the values of 1, 2, 3, 4, 10, 14.14, 20, and 35; while R34 assumes the values of 10, 12.5, 15, 20, 50, 100, 150, and 200.

If TIME is specified as either a swept or parametric variable, the user must insure that the sequence of time values which he specifies is monotonically increasing.

6.1.1.3 Topology Changes

Since switches may have numerical values, it is possible to change network topology in a deliberate manner in a State solution.

6.1.2 Specification of DC Steady State and Transient Calculation

In general NET-2 will perform both the DC steady state calculation and the transient calculation whenever a TERMINATE Entry is included in the input and the termination condition is not satisfied by the DC steady state response. The exception to this rule occurs only when contrary instructions are given in a particular State solution. An example which produces only the DC steady state calculation is:

```
TERMINATE = N(35)-57
STATE6
    TIME 0
    PRINT N(46)
```

Similarly, if the TERMINATE Entry is missing, the transient calculation will never be performed unless specifically requested by a nonzero value of TIME in a particular State solution:

```
STATE7
    TIME 0 35 80
```

6.1.3 Device Modes

Modes of devices may be specified during the initial DC steady state calculation by using the word `MØDE` as a device parameter name for a specific device followed by a desired mode, starting at indentation level 1 in a STATE Entry. For example:

```
STATE3
  T1.MØDE ØFF
```

6.1.4 Output Statements

The output statements specify which response variables are to be calculated, and how the results are to be presented. Since it is possible to vary network parameters over a range of values, the output statements can include plotting specifications.

Quantities which may appear as output include all network parameters, X variables, symbolic constants, and response variables. The output statement must not include mathematical expressions, numerical constants, function references, or table references.

6.1.4.1 Print Statement

This statement begins on indentation level 1 and specifies the quantities which are to be printed. An example is:

```
STATE3
  PRINT R1 HT5.T35.BN N(1) A'(1-0/2-0) N(2) FREQ
```

This statement causes the printing of the quantities which are named in the statement. Phase angle of AC small signal variables is printed in degrees. It is not necessary to include parametric variables in the print statement since they are automatically printed as headings. The swept variable is also automatically printed.

A maximum of 10 quantities may be specified in each print statement, including the swept variable.

6.1.4.2 Plot Statement

This statement begins on indentation level 1 and specifies the quantities to be plotted as well as the coordinate system to be used in plotting. The independent variable is specified last, following the word VS. If no coordinate system is specified, a linear system is used. Each plot statement produces a separate graph. Examples of plot statements are:

STATE3

```
  PLOT N(L) VS R3
  PLOT LINLOG A(1-0/2-0) Z(1-0/1-0) VS FREQ
```

As many dependent variables as desired may be listed before the word VS. Obviously, only one independent variable may be named. The phase angle of AC small signal variables is plotted in degrees.

Coordinate systems are specified after the word PLOT. Choices are:

No specification	Linear in both dependent and independent variables.
LINLOG	Linear dependent and logarithmic independent variables.
LOGLIN	Logarithmic dependent and linear independent variables.
LOGLOG	Logarithmic in both dependent and independent variables.
POLAR	Dependent variable is plotted on polar coordinates (linear magnitude and phase) as a sequence of points corresponding to the swept variable values.

For POLAR plots an independent variable is never specified because both coordinates refer to the dependent variable. The format is shown by this example:

```
PLOT POLAR A(3-0/2-4) Z(2-0/3-5)
```

Obviously, the usage of POLAR coordinates is restricted to the AC small signal variables. The magnitude of the AC small signal variable is always specified when using POLAR coordinates.

In order to produce a meaningful graph there must be either a transient calculation requested or a swept variable specified.

If no independent variable is specified for a given graph, the swept variable will be used automatically. Thus,

```
STATE3
  R3 1 (10) 20
  PLØT I(L3)
```

will produce a plot of I(L3) versus R3.

Each curve in a given PLØT statement will use a different plotting symbol. The symbols used, in order, are X123456789ABCDEFGHIJKLMNØPQRSTUVWXYZ. The first curve is the first dependent variable specified in the PLØT statement using the first set of parametric variable values; this is followed by the next dependent variable specified, etc., until all dependent variables have been plotted for the first set of parametric variable values. The sequence is then repeated using the next set of parametric values until all sets of parametric variable values have been exhausted.

6.1.5 Special Requirements for Output in Transient Calculations

When a transient calculation is indicated, it is possible to generate a multidimensional set of data points. Since display of multidimensional graphs is not feasible, special provisions must be made to reduce the display to two-dimensional form.

An example of multidimensional output is given by the following example, which involves AC small signal evaluation throughout the transient response:

```
*R5 1 (10) 5
FREQ 1 (25*) 50
PLØT A(1-0/3-0) VS FREQ
```

We have here the normal two-dimensional solution variation, given by changes in FREQ and R5. However, since the transient solution is being calculated, we have a large number of solution points generated for each of the specified calculations, each at a different value of time. If each transient solution consists of 1000 points in time, the overall output for each dependent variable consists of a set of 10x25x1000 or 250,000 data points! Even if the display could be implemented, it would contain far too many points to be readable. Similar difficulties arise when the output is printed instead of plotted. Note that this problem can never arise in DC steady state calculations.

The solution to the above problem is to hold one of the variables at a constant value for a given graph, thus reducing the problem to a family of two-dimensional displays.

Generally, one desires to fix the value of time and then sample the transient calculation at that particular time. This can be done by merely specifying a numerical value for TIME for example:

```
TIME 600
```

If one wishes to sample at the termination of the transient response, as specified by the TERMINATE Entry, the word FINAL is specified for the time value:

```
TIME FINAL
```

The word FINAL must never be used unless there is also a TERMINATE Entry supplied.

Similarly, one may wish to specify TIME as the swept variable. In this way, the user controls the value and number of points in time where output is taken. The final value of time is indicated by the word FINAL. Since the final value of time may not be known in advance by the program, the word FINAL may not be immediately preceded by a step number in parentheses. An example is:

```
TIME 0 (3) 600 FINAL
```

Finally, the user may wish to specify TIME as the parametric variable, thus producing a series of curves, one for each value of TIME specified:

```
*TIME 0 (3) 600 FINAL
```

Again, the word FINAL may be used but it cannot be immediately preceded by a step number in parentheses.

If, in the above examples, the termination condition is satisfied before TIME reaches 600, termination will not occur until TIME reaches 600.

Note that the above rules are applied only when it is required that the values of TIME be restricted to particular values. In the case where one merely wishes to plot all the data corresponding to every time point in the transient calculation, the above technique is not used.

Instead, the swept variable is not even specified. In this event, TIME is automatically the swept variable and every value of TIME is used. Naturally, TIME cannot be used as a parametric variable in such a case. An example is:

```
*R5 1 (3) 5  
PLOT N(1) VS TIME
```

which would plot the requested information with a separate curve for each value of R5.

One may also specify some other quantity as the independent variable. In this case, the various points in the curve would correspond to successive values of TIME, but the curve would be a function of the two quantities specified:

```
PLOT N(1) VS I(L5)
```

An independent variable is never specified for plots in polar coordinates.

6.1.5.1 Examples of Legal Forms for Transient Calculations

In the following examples, a parametric variable is usually included, even though in practice it is optional. Although all the examples are plotted, the appropriate PRINT expression may also be used.

1. A series of curves corresponding to different values of TIME is required. Each curve represents a plot of voltage gain versus frequency. The values of frequency to be used are specified:

```
STATE1
  *TIME 3 (7*) 550 600
  FREQ 1 (10*) 50
  PLOT A(1-0/3-0) VS FREQ
```

2. A series of curves corresponding to different values of TIME is required. Each curve is a polar plot of voltage gain, with the individual points in the curve representing particular frequency values. The values of frequency used are specified:

```
STATE2
  *TIME 35 FINAL
  FREQ 1 (10*) 50 60
  PLOT POLAR A(1-0/2-8)
```

3. A series of curves corresponding to different values of TIME is required. Each curve represents a plot of one node voltage versus another node voltage, with the individual points in the curve corresponding to different values of R5. The values of R5 to be used are specified:

```
STATE3
  *TIME 0 FINAL
  R5 3 7 10
  PLOT N(1) VS N(3)
```

4. A single curve at a specific value of TIME is required. The curve is a plot of voltage gain versus frequency. The values of frequency to be used are specified:

```
STATE4
  TIME FINAL
  FREQ 1 (10*) 50
  PLOT A(2-0/4-0) VS FREQ
```

5. A series of curves corresponding to different values of R6 is required. Each curve is a plot of the value of a node voltage at a specific value of TIME versus R5. The values of R5 to be used are specified:

```
STATE5
  *R6 3 7 9
  TIME 57
  R5 3 (20) 70
  PLOT N(1) VS R5
```

6. A series of curves corresponding to different values of R6 is required. Each curve is a plot of a node voltage versus another node voltage, where both node voltages are sampled at a specific value of TIME. The points in the curve correspond to different values of R5. The values of R5 are specified:

```
STATE6
  TIME 89
  *R6 3 5 10
  R5 2 (15) 20
  PLOT N(1) VS N(2)
```

7. A series of curves corresponding to different values of R5 is required. Each curve is a plot of a node voltage versus TIME. Specific values of TIME are specified:

```
STATE7
  TIME 3 (10) 500
  *R5 2 5 8
  PLOT N(1) VS TIME
```

8. A series of curves corresponding to different values of frequency is required. Each curve is a polar plot of voltage gain. The individual points in each plot correspond to specific values of TIME. These TIME values are specified:

```
STATE8
  TIME 1 34 (20) 89 FINAL
  *FREQ 1 4 9
  PLOT POLAR A(1-0/3-0)
```

9. A series of curves corresponding to different values of R6 is required. Each curve is a plot of a node voltage versus another node voltage. The individual points in the curve correspond to specific values of TIME. These TIME values are specified:

STATE9

```
TIME 7 (20) 30 (40) 100
*R6 5 8 9 10
PLOT N(1) VS N(2)
```

10. A series of curves corresponding to different values of FREQ is required. Each curve is a polar plot of a voltage gain. The individual points in each curve correspond to successive values of TIME, but these values are not specified (i.e., all TIME values are needed):

STATE10

```
*FREQ 3 6 8
PLOT POLAR A(5-0/5-6)
```

11. A series of curves corresponding to different values of R7 is required. Each curve is a plot of a node voltage versus TIME. All values of TIME are used in the curve:

STATE11

```
*R7 4 8
PLOT N(1) VS TIME
```

12. A series of curves corresponding to different values of R7 is required. Each curve is a plot of a node voltage versus another node voltage. The individual points in each curve correspond to successive values of TIME, but these values are not specified (i.e., all values of TIME are needed):

STATE12

```
*R7 5 8 15
PLOT N(1) VS N(2)
```

7. MONTE CARLO SOLUTION

NET has the capability of synthetically constructing a large number of networks, each composed of network parameters with different values, analyzing the performance of each of these networks, and then summarizing the results as a set of performance statistics. Such a calculation is known as a Monte Carlo solution.

The Monte Carlo solution randomly picks network parameters whose spread in value have known population distributions. The resultant networks will then have response variable population distributions which are statistically identical to the actual network in mass production.

NET requires information regarding the shape of the distribution curves for the network parameters and the limit values for these curves.

7.1 Distribution Entry

The user may specify the shape of any distribution curve by means of the Distribution Entry. The format is:

```
DISTn
  v1 n1
  v2 n2
  .
  vn nn
```

where: v_k = value of the curve at point n_k .

n_k = value of an arbitrary point on a linear scale.

Both ends of the curve must be included (the zero value points). These two ends correspond to the limit values of the distribution. Note that n_1 corresponds to the minimum magnitude value point and n_n to the maximum magnitude value point.

The n_k items may be omitted if they are equally spaced.

Examples of Distribution Entries are:

```
DIST65
  0 3
  5 6
  7 10
  3 12
  0 15
```

```
DIST34
  3
  6
  12
  13
  9.5
  3
```

7.2 MONTECARLO Entry

The MONTECARLO Entry specifies the limit values for the network parameters (including TIME and FREQ) and the distribution shape to be applied between these limits. An output statement is also included to indicate which quantities are to be tabulated.

7.2.1 Parameter Values

Each parameter of interest is specified by an indented line containing the parameter ID, the distribution shape, and the limit values. The available distribution shapes include rectangular, Gaussian, triangular, and arbitrary shapes (as specified by a corresponding Distribution Entry). In addition, specific parameters may be set to new constant values (as in the State solution), and topology may be changed. An example of a MONTECARLO Entry is:

```
MONTECARLO35
  R6 GAUSS .9*
  S3 0
  T1.RBB RECT .05 .09
  LC3.V2 TRI -24 1.1*
  FREQ GAUSS 45.7
  TIME 45
  R35 DIST5* .5* 2*
  S14 RECT -.7 .3
  T1.MODE OFF
```

If the limit value is suffixed by an asterisk, a relative value is specified. The actual value is then the product of the relative value and the nominal value.

The GAUSS shape is a Gaussian curve with the limit values specified at the 3σ points. Since the shape is symmetric, only one limit value is required.

The RECT shape is a constant value distribution between the two limit values.

The TRI shape is a triangular distribution with the limit values corresponding to the bottom corners of the triangle, and the nominal value corresponding to the apex of the triangle. Obviously, the nominal value must fall between the two limit values.

The DIST shape specifies an arbitrary shape corresponding to the named Distribution Entry. The first limit value corresponds to the minimum value, the second to the maximum value in the appropriate Distribution Entry.

If any shape word is suffixed with an asterisk, the distribution is taken in logarithmic space between the limit values instead of linear space.

7.2.2 Output Statements

The MØNTECARLØ Entry includes lines on indentation level 1 which specify quantities to be tabulated and the means of tabulation. Output quantities may include any network parameter, time, frequency, X variable, symbolic constant, and response variable. The output statement must not include mathematical expressions, numerical constants, function references, or table references.

Tabulation may be done either by printing or plotting. If printing is specified, the tabulation includes each individual network calculation. Plotted information is presented in histogram form. Only one output quantity may be named in each PLØT statement. Examples of output statements are:

```
MØNTECARLØ89
  PRINT R1 N(1)
  PLØT T1.RBB
  PLØT A(1-0/3-0)
```

The phase angle of AC small signal variables is printed and plotted in degrees.

7.2.3 Time Point of Sampling

The Monte Carlo solution must sample the values of the output quantities at one and only one point in time. If a TERMINATE Entry is included in the input this sampling will occur whenever the terminate condition is satisfied, unless the specific MØNTECARLØ Entry contains either a statistical or constant specification of TIME, in which case sampling will occur at that value of TIME. If there is no TERMINATE Entry and no TIME specification, the sampling will be done at the conclusion of the DC steady state calculation.

7.2.4 Number of Monte Carlo Cases

The total number of networks to be constructed by NET during each Monte Carlo solution is given by a line containing the word CASES and the specified number. This line is included under the MØNTECARLØ Entry at indentation level 1. An example is:

```
MØNTECARLØ78
  CASES 150
```

8. OPTIMIZATION SOLUTION

The Optimization solution is probably the most powerful feature of NET-2. With this type of solution, it is possible to optimize network response to achieve a particular design goal.

The Optimization solution attempts to attain the desired optimum by a minimization process which varies specific network parameters within an allowable parameter space. The optimum attained is not guaranteed to be a global optimum, but may be only a local one.

The values of the network parameters which produce the optimum condition automatically replace the nominal values of these parameters for all subsequent solutions (unless further changed by a subsequent Optimization solution). This is done to permit the user to find a set of optimum network parameters and then perform State, Monte Carlo, or further Optimization solutions on the optimized network.

8.1 OPTIMIZE Entry

The OPTIMIZE Entry specifies the network parameters which may be varied and their ranges, constraints imposed between network parameters, and a series of operational states for the network configuration. Within each operational state a number of additional items may be specified.

The OPTIMIZE Entry begins with a line on indentation level 0 of the format:

```
OPTIMIZEn
```

This line indicates a specific Optimization solution. All lines pertaining to this particular solution follow this line and are indented.

8.1.1 Network Parameter Ranges

A series of lines at indentation level 1 specify various network parameters (including FREQ) and the lower and upper limits for their values. In achieving the optimum solution only values of these parameters which fall between the limits specified may be used. An example is:

```
OPTIMIZE46  
  R5 .005 .016  
  FREQ 1 1.5*
```

Note that relative values may be indicated by suffixing the value with an asterisk. The actual value is then the product of the relative value and the nominal value.

8.1.2 Network Parameter Constraints

It is possible to impose constraints on network parameters which do not have ranges specified. These constraints are expressed by mathematical expressions which are written in terms of network parameters which have ranges specified. For example:

```
ØPTIMIZE75  
  R5 .005 .016  
  R6 = R5/2
```

This insures that no matter what value R5 assumes in the optimization, R6 will always be half of R5 in value. These constraints are always written at indentation level 1.

8.1.3 Operational States

The operational state information is very similar to the information specified under the STATE Entry. It specifies any additional information pertaining to network parameter values, lists the objective function(s) to be minimized, and permits the transient calculation to be bypassed if desired. There may be many different operational state entries, each corresponding to a different mode of operation for the network.

Each operational state is introduced by a line containing the word STATE on indentation level 1. This is then followed by one or more lines on indentation level 2 which give the details for that particular operational state.

In the actual optimization process all of the operational states are considered "simultaneously." Thus the optimized network gives the "best" performance in each of the states specified.

The usage of the operational state is best explained by referring to an extended example:

```
ØPTIMIZE18
  STATE
    V6 -7
    S12 0
    TIME 0
    ØBJ = N(1)/I(L5)
  STATE
    ØBJ = I(L5)**2 VS CURVE3 .25
    S12 1
    ØBJ = N(1) VS CURVE5 .50
  STATE
    ØBJ = A(1-0/3-4) VS CURVE2 .35 X
    TIME 47
    FREQ 10 (20*) 100
    TL.MØDE ØFF
```

Note the similarity to the STATE Entry. The basic differences are:

1. The indentation level is increased by one.
2. The word STATE does not have a numerical suffix.
3. The output statements have been replaced by objective function statements.
4. No parametric variable is permitted.

8.1.3.1 Objective Function Statements

Two different forms of objective function statements are permitted. One form, called the point form, is usable when only a single value for each network response variable is calculated; the other form, called the curve form, is used in conjunction with a swept variable.

The point form is shown in the first operational state in the example above. It consists of the word ØBJ, an equal sign, and a mathematical expression whose value is to be minimized. This mathematical expression is evaluated only once during a particular response calculation. If the DC steady state response is specified, then it is evaluated at the DC operating point. If the transient response is specified, it is evaluated at the termination of the transient calculation. There is no restriction on the form of the mathematical expression.

The curve form is shown in the second and third operational states in the above example. It requires a series of values for some mathematical expression for various values of a swept variable. If the swept variable is TIME, a set of time values must be supplied.

The curve form is specified, in order, by the word OBJ, an equal sign, any mathematical expression, the word VS, the name of a curve, a weighting constant, and an optional fitting parameter.

The curve form actually specifies a curve fitting process. The curve name refers to the definition of a specific curve shape which is included somewhere else in the NET-2 input. It is required to fit the values of the mathematical expression as closely as possible to the curve values in the least squares sense. The independent variable for the mathematical expression values and the curve is always the swept variable.

The curve is normally required to be fit as exactly as possible in the least squares sense. However, by including the optional character X at the end of the curve form statement, it is possible to do the fitting to within a linear transformation. This transformation will be chosen by NET-2, and generally its value is of no interest to the user.

The value of the curve form objective function is given by the following expression:

$$\text{Value} = W \frac{\sum_{i=1}^n w_i \left(a Z(x_i) + b - Y(x_i) \right)^2}{\sum_{i=1}^n w_i}$$

- where W = the objective function weight
 n = the number of sample points
 w_i = the weight for value $Y(x_i)$ on the curve
 x_i = the value of the swept variable at the i th sample point
 $Z(x_i)$ = the value of the mathematical expression at the i th sample point
 $Y(x_i)$ = the value of the curve at the i th sample point
 a = constant for linear transformation (a = 1 if optional character X not included)
 b = constant for linear transformation (b = 0 if optional character X not included)

There is no restriction on the number of objective functions which may appear under a given operational state. Both point form and curve form objective functions may not be used in the same operational state.

The Optimization solution minimizes the sum of the values of all objective functions for all specified operational states.

8.2 CURVE Entry

The CURVE Entry specifies the shape and weights for the curve required by the curve form objective functions. The CURVE Entry consists of several lines, with the first line beginning at indentation level 0, and subsequent lines beginning at indentation level 1. The format is:

CURVEN

```
x1 y1 w1
x2 y2 w2
.
.
xm ym wm
```

where: CURVEN = curve ID
x₁, x₂, etc. = values of the swept variable
y₁, y₂, etc. = values of the curve corresponding to x₁, x₂, etc.
w₁, w₂, etc. = values of the curve weights corresponding to
x₁, x₂, etc.

The specification of the weights for any point is optional. If the weight w_i is not specified, it is assumed w_i = 1.

8.3 Optimization Results

When the minimum of the sum of the objective functions has been attained, the value of the minimum is printed. Also printed are the values of all network parameters which have been varied to produce the minimum. The values then become the nominal values for these network parameters for subsequent calculations.

9. DEVICE PARAMETER AND STORED MODEL LIBRARY MAINTENANCE

NET-2 includes facilities for the maintenance of the device parameter library and the stored model library. This maintenance is specified by entries which may be part of the NET-2 network description. Alternatively, maintenance may be accomplished as a separate NET-2 run.

9.1 LIBRARY Entry

The LIBRARY Entry may appear as part of the NET-2 input. This entry consists of the word LIBRARY on indentation level 0, followed by several indented subentries which specify printing, modification, copying and deletion of library contents.

The library contents are manipulated in the same order as the various subentries are listed. All library maintenance is accomplished immediately after the input has been read, so that all calculations of network response will use the updated library contents.

Only one LIBRARY Entry is permitted in the NET-2 input.

9.1.1 Device Parameter Library Print

The word PRINT on indentation level 1, followed by the word DPL, may be used as a subentry heading to indicate that a listing of the device parameters for specified modeled devices is desired. The lines which follow indicate which modeled devices are desired. An example is:

LIBRARY

```
  PRINT  DPL
    D  1N279
    T  2N1307
```

Note that the lines specifying the desired modeled devices appear on indentation level 2. There may be as many such lines as desired, with the order of printing the same as the order in which the lines are listed. Each line must specify the appropriate prefix for the device (e.g., D for diode, T for transistor) followed by the device type name.

A copy of the device parameter library master list is always printed first.

If more than one set of listings is desired, the number of copies of the printout may be specified by an integer following the word PRINT and DPL. A space must intervene between the word DPL and the integer. For example:

```
LIBRARY
  PRINT DPL 5
    D 1N279
```

If a printout of the entire library is desired, the word ALL may be used in place of the device specification lines:

```
LIBRARY
  PRINT DPL
    ALL
```

9.1.2 Device Parameter Library Modification

It is possible to add new devices to the device parameter library or modify parameter values of existing devices in the device parameter library. A device specification line is used on indentation level 1 to indicate which device is involved. For example:

```
LIBRARY
  D 1N279 1
    RB .005
    IS .00013
```

The device specification line shows, in order, the device prefix, the device type name, and the model number for the device. If the device is already in the library the model number may be omitted; for new devices the model number must be included.

Following the device specification line, a series of device parameter specification lines on indentation level 2 are listed, one for each parameter value of interest. These lines give the parameter value symbol followed by the numerical value of the parameter. If the device is already in the library, the listed parameter values replace the original values in the library. If the device is not in the library, the listed parameter values become the device parameter values in the library, with NET-2 providing default values for any device parameter values which are not listed.

It is not possible to change the type name or model number of a device already in the library except by first deleting the existing device (see below) and then adding a new device to the library.

A listing of all parameter values of the device involved in the library modification will be produced automatically.

9.1.2.1 Device Parameter Data Reduction

NET-2 contains facilities for automatically determining certain modeled device parameters from measurement data supplied in numerical form. Information for this data reduction feature always appears as a subentry under a device specification line in the Library Entry. The general format is:

```
LIBRARY
  devspec
    paramspec
      DATA drtype fixedparams / startparams
          dataset1
          dataset2
          .
          .
          .
```

where: devspec = device specification line
paramspec = device parameter specification line
drtype = data reduction type code
fixedparams = list of parameter symbols whose values are to be fixed at prescribed values
startparams = list of parameter symbols whose prescribed values are to be used as starting values for data reduction
dataset1, dataset2, etc. = sets of numerical values for data points.

NET-2 will modify the parameter values in the library according to any device parameter specification lines which may be included for a given device before the data reduction process is started. Then, using these parameter values, NET-2 will enter the data reduction phase, generating additional parameter values as required.

The DATA card always starts at indentation level 2 and specifies the type of data reduction and any constraints and/or initial starting values desired by the user. Sets of numerical data including optional weighting values always follow the DATA card at indentation level 3.

The user may elect to have certain parameter values held constant during the data reduction process (normally these values would be calculated as part of the data reduction). This can be done by including the symbols for these parameters in the optional fixedparams field on the DATA card. Only parameters which are calculated by the specified data reduction type may be included in the fixedparams field. The values of the remaining parameters are calculated so as to be consistent with the fixed parameter values.

The user may also wish to specify a set of starting values to assist NET-2 in the data reduction process. This can be done by including the symbols for these parameters in the optional startparams field. The startparams field must be prefixed with a slash when it is used. NET-2 will then begin the data reduction process using the specified values for these parameters, but as the data reduction progresses, these values will be modified so as to give an optimal fit to the data points. Only parameters which are calculated by the specified data reduction type may be included in the startparams field.

The data reduction type code (drtype) specifies the type of data reduction which is required and the quantities which are to be supplied in the datasets following the DATA card. The last member of each dataset is an optional weighting factor; if omitted, NET-2 will automatically supply a value of unity. The data points are not required to be ordered, although machine sort time can be saved if they are in ascending order. The number of data points supplied must exceed the number of parameters to be calculated for a given data reduction type.

When the calculated parameter values are printed, standard error values will also be printed in parentheses for those values which have been extracted from the data point information.

There may be more than one data reduction associated with a given modeled device. The final set of device parameter values after all data reduction steps have been completed are entered into the device parameter library and used for subsequent calculations.

An example of the format for data reduction is:

```
LIBRARY
  T 2N4598 4
    RBB .001
    IES 1E-9
    DATA DCN1 RBB THE/IES
      .15 12 1E-10 .3
      .25 14 2.3E-10 .35
      .
      .
    THE 38
```

In this example data reduction for a bipolar transistor (type name 2N4598) is performed using the numerical data which is included at indentation level 3 following the DATA card. The code DCN1 specifies the data reduction type desired, in this case the normal forward emitter-base characteristic for DC operation. DCN1 also specifies the meaning of the numerical entries which are supplied as data; in this example each dataset card specifies, in order, base-emitter voltage, normal common emitter current gain β_n , emitter current, and the weighting factor associated with the data point.

The parameter values for RBB and THE which are normally calculated by the DCN1 type of data reduction have been declared as fixed value parameters. Their values will thus be held constant at the values of .001 and 38, respectively, as specified by the appropriate device parameter specification lines.

The parameter symbol IES appears in the startparams field. Thus, a value of 1E-9 for IES as specified in the device parameter specification line will be used as a starting value for IES in the data reduction process.

Details of the various types of data reduction are included in the modeled device descriptions in Chapter 2.

9.1.3 Deletion of Devices

A device in the device parameter library may be deleted by including the word DELETE, followed by DPL, as a subentry heading on indentation level 1.

Device specification lines then follow on indentation level 2 to indicate which devices are to be deleted. The device specification lines list, in order, the device prefix and the type name. For example:

```
LIBRARY
  DELETE DPL
        D 1N279
        D 1N645
```

9.1.4 Copy Device Parameter Library

A copy of the device parameter library may be made at any point in the library maintenance operation by including the word COPY, followed by DPL, as a subentry heading on indentation level 1. For example:

```
LIBRARY
  COPY DPL
```

The COPY subentry may be preceded and followed by other library maintenance subentries if desired. The library copy will reflect the status of the device parameter library as it exists at that point in the maintenance sequence. This copy is made on FORTRAN logical unit 11.

9.1.5 Stored Model Library Print

The word PRINT on indentation level 1, followed by the word SML, may be used as a subentry heading to indicate that a listing of the descriptions of specified stored models is desired. The lines which follow indicate which stored models are desired. An example is:

```
LIBRARY
  PRINT SML
        PQ
        WTH
```

Note that the lines specifying the modeled devices appear on indentation level 2. There may be as many such lines as desired, with the order of printing the same as the order in which the lines are listed.

A copy of the stored model library master list is always printed first.

If more than one set of listings is desired, the number of copies of the printout may be specified by an integer following the words PRINT and SML. A space must intervene between the word SML and the integer. For example:

```
LIBRARY
  PRINT SML 5
        RHTY
```

If a printout of the entire library is desired, the word ALL may be used in place of the stored model specification lines:

```
LIBRARY
  PRINT SML
        ALL
```

9.1.6 Deletion of Stored Models

A stored model may be deleted from the stored model library by including the word DELETE, followed by the word SML, as a subentry heading on indentation level 1. The names of the stored models which are to be deleted are then listed, one per line, on indentation level 2. For example:

```
LIBRARY
  DELETE SML
    PQ
    RHTY
```

It is not possible to add new stored models or modify existing stored models in the stored model library through the LIBRARY Entry. This is accomplished with the MØDEL Entry as described in Chapter 5.

9.1.7 Copy Stored Model Library

A copy of the stored model library may be made at any point in the library maintenance operation by including the word CØPY, followed by SML, as a subentry heading on indentation level 1. For example:

```
LIBRARY
  CØPY SML
```

The CØPY subentry may be preceded and followed by other library maintenance subentries if desired. The library copy will reflect the status of the stored model library as it exists at that point in the maintenance sequence. This copy is made on FORTRAN logical unit 10.

10. INPUT PREPARATION

Input to the NET-2 program consists of a deck of punched cards. Preparation of the cards is done on a standard printing card punch. Columns 1 through 72 are available for punching NET-2 input. Columns 73 through 80 may be used for any other purpose such as card sequence number or identification.

10.1 Order of Entries

In general, the order in which the various entries are listed in the input is immaterial, except for the STATE Entry, MONTECARLO Entry, and OPTIMIZE Entry. The sequence of calculation for the STATE, MONTECARLO, and OPTIMIZE Entries is in the same order as these entries are listed in the input. The user should remember that after each Optimize solution, the nominal circuit values will have been changed (see chapter 8).

10.2 Representation of Indentation Levels

The user may specify which columns correspond to the start of the various indentation levels, other than indentation level 0.

Indentation level 0 always begins in column 1. Other indentation levels are assigned a starting column by the user and punched accordingly. It is not necessary to adhere to the same starting column for a given indentation level except within the same entry.

10.3 Card Continuation

Many times it will not be possible to punch a complete NET-2 line on one card, particularly when long mathematical expressions are used. A continuation symbol may be punched whenever a space would normally occur. The line is then continued on the next card. If the second card does not have adequate space to complete the line, a continuation symbol is punched in lieu of a space and a third card used, and so on, up to a maximum of five cards per line. It is not necessary to observe the indentation rules when starting new cards following the continuation symbol. These cards may be started in any column. Of course, when the punching of the line has been completed, the next card must observe the proper indentation rules for the next line.

The symbol \$ is used for the continuation symbol. It will be interpreted as a space by NET-2.

10.4 Comment Cards

The user may insert comment cards in his NET circuit description deck. Each comment card must have an asterisk punched in column 1. These comment cards will be listed as part of the NET circuit description listing but will not affect network response calculation. Since comment cards are written on indentation level 0 they must not be inserted in the middle of an indented sequence of cards such as a Table Entry.

NET will use the first card in every input deck as a title for labeling output. It is recommended that this first card in the deck be a comment card.

An example of a comment card is:

*NEGATIVE IMPEDANCE AMPLIFIER, STATISTICAL STUDY

10.5 Punching of Entries

The NET-2 input which describes the network configuration and the control and output requests is punched, following the rules set forth above for indentation and continuation, and using the formats described in this report. The IBM 360/370 version of NET-2 will accept both BCD and EBCDIC punched cards.

NOTE: The prime symbol is not a valid symbol on the CDC 6000 system. However, NET-2 is written so that the 6000 version will interpret an 8-4 punch (BCD input) or an 8-5 punch (EBCDIC input) as a prime symbol. The prime symbol will be represented by the symbol † on the printed listing.

10.6 Time Limit Specification and Checkpoint/Restart Option

Both the IBM 360/370 and CDC 6000 operating systems require that the user specify a time limit for all jobs submitted (in the absence of such specification a default value is assigned). When this time limit is reached the system will terminate the job automatically. In the event that calculation has not been completed at the expiration of the allotted time it is desirable to be able to obtain any available output and to save the status of the run to permit continuation from that point at a later time.

NET-2 contains optional checkpoint/restart facilities to permit automatic recovery in the event of time limit expiration. Checkpoint/restart will be provided only if the NET-2 deck contains the card:

DEBUG 1

and the time limit is greater than 60 decimal seconds for the IBM 360/370 version, or 100 octal seconds for the CDC 6000 version.

The CDC 6000 version is able to capture time limit specification automatically. However, the user must supply a time limit card in the NET-2 deck for the IBM 360/370 version if time limit checking is required. The format for this entry is:

TLIM Time

where Time = time limit in decimal seconds.

10.7 END Card

The input deck is concluded by punching a card with the word END, beginning in column 1.

10.8 Multiple Runs

NET-2 will accommodate a series of unrelated network analysis runs if desired. The individual input decks, each concluding with an END card, are placed one after another with no intervening cards to form a multiple run input deck. The various input decks are then processed in the same order as they appear.

The use of this feature produces a more efficient execution of NET-2 in the batch processing mode. However, the entire multiple run will be terminated if the operating system encounters an unrecoverable error of any type, such as an arithmetic overflow.

11. EXAMPLE PROBLEMS

This chapter presents five NET-2 example problems. The first four problems are self contained and should be able to be run with NET-2. The fifth example illustrates the use of mathematical expressions and is not designed to actually run on NET-2; it is included only for illustrative purposes.

The Video Amplifier Example features the use of the Library Entry, the Define Entry, neutron radiation effects, frequency domain transfer functions evaluated during the transient solution, and parametric variables. Note the use of the switch S1 which is connected between interior nodes of a defined subcircuit. The listing for this example is:

*VIDEØ AMPLIFIER EXAMPLE LIBRARY

```
ZD 1N758A 2
  RB 15E-5
  GC 1.12E-7
  W 4.01E-3
  C 350
  VZ .9
  N .412
  TH 37.7
  IS 1.6E-11
  A 15
  B 1
  VB -8.2
D 1N914 1
  RB 8E-3
  GC 2.857E-7
  IS 2.1E-6
  VZ .5
  N .5
  W 6.28E-2
  TH 22.639
  C 3.98
```

T 2N2857 4
GE 1E-4
GC 1E-4
A1 1
A1 1
B1 1
BN 64.6
BI .53
IES 1.35E-12
ICS 3.31E-12
THE 36.1
THC 35.9
WN 3.78
WI .0278
CE 1
VZE 2
NE .22
CC 1.22
VZC 2
NC .251
S 1
RBB .0183
RCC 4.28E-3
KAN 7.998E-17
KAI 4.573E-17

C1 V1 1 220E3
C2 6 0 1E6
C3 5 0 1E6
C4 4 0 10
R1 1 2 2.2
R2 4 0 2.2
R3 5 6 .1
R4 V2 5 .075
S1 NHD2.8 NHD2.13 1

```

DEFINE NHD 2 16 13 0
  R1 3 6 200
  R2 6 0 1E3
  R4 4 5 1
  R5 5 7 390
  R6 7 0 5.1
  R7 2 7 82
  R8 2 8 82
  R9 7 9 5.1
  R10 10 0 12
  R11 8 10 27
  R12 11 0 12
  R13 13 8 .1
  R14 14 15 .1
  R15 13 12 2
  R16 15 0 1.3
  C2 3 4 220E3
  C3 8 0 1E6
  C4 9 10 .2E6
  C6 15 0 .33E6
  C7 12 16 .2E6
  D1 2 3 1N914
  D2 5 0 1N914
  ZD5 0 6 1N758A
  T1 9 2 8 2N2857
  T2 11 10 12 2N2857
  T3 14 11 12 2N2857
NHD1 2 3 6 0
NHD2 3 4 5 0
V1 V1 0 U(TIME-.001)
V2 V2 0 22
P1 0
NEUT = P1, 0
STATE3
  TIME 1
  *P1 0 5E13 1E14 5E14
  FREQ .00001 (50*) .02
  PLOT LINLOG A(4-0/V1-0)
  PLOT LINLOG Z(2-0/2-0)
  PLOT LINLOG Z(3-0/3-0)
  PLOT LOGLOG A'(4-0/V1-0) Z'(2-0/2-0) Z'(3-0/3-0)
END

```

The Montecarlo Example shows the use of various distribution shapes, the use of linear and logarithmic distributions, and the use of actual and relative limits on the distributions. The listing for this example is:

```
*MONTECARLO EXAMPLE
R1 V1 1 1
R2 1 0 2
V1 V1 0 1
R3 1 0 2
MONTECARLO1
  R1 DIST1 .5* 1.5
  R2 TRI* .5 1.5*
  R3 GAUSS .5*
  V1 RECT .5 1.5
  CASES 10
  PRINT I(R1) N(1) P(R2)
  PLOT N(1)
  PLOT I(R1)
DIST1
  0
  .3
  1.0
  0
END
```

AD-A078 975

BRADDOCK DUNN AND MCDONALD INC EL PASO TEX F/G 9/5
NET-2 NETWORK ANALYSIS PROGRAM, RELEASE 9. USER'S MANUAL, (U)
SEP 73 A F MALMBERG DAAG39-70-C-0050

UNCLASSIFIED

HDL-050-1

NL

3 of 3
AD
A078975



END
DATE
FILMED
2-80
DDC

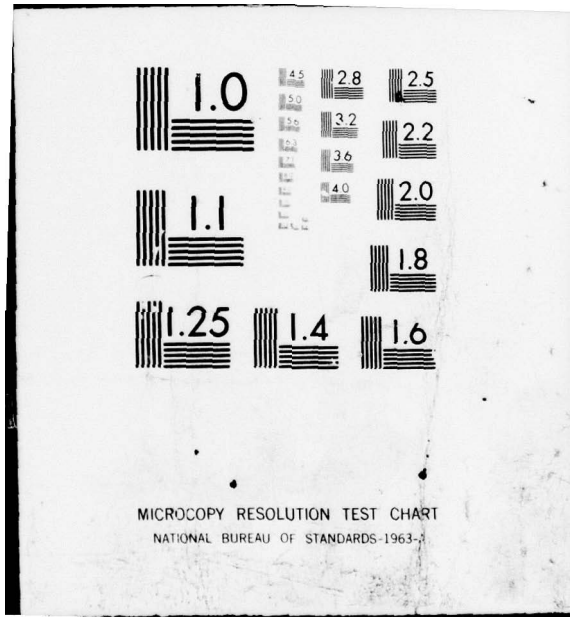

The AC Bridge Optimization Example illustrates the optimization of a circuit in the frequency domain. In this example it is desired to minimize the voltage gain transfer function, i.e., balance the bridge, by varying the exciting frequency. The optimization is followed by a state solution which explores the variation of the voltage gain with the inductance L1 using resistor R1 as a parametric variable. This exploration is done using the bridge balance frequency found by the optimization. The listing for this example is:

```
*AC BRIDGE OPTIMIZATION EXAMPLE
```

```
C1 1 4 10
```

```
C2 4 5 10
```

```
C3 4 0 1100.1
```

```
C4 3 0 9.99
```

```
C5 1 3 10
```

```
R1 2 4 .005
```

```
R2 3 5 31.9435
```

```
L1 2 0 13.7E3
```

```
FREQ 1
```

```
OPTIMIZE6
```

```
  FREQ 40E-6 41E-6
```

```
  STATE
```

```
    OBJ=A(5-0/1-0)
```

```
STATE3
```

```
  PLOT A(5-0/1-0) VS L1
```

```
  L1 13.3E3 (6) 14.1E3
```

```
  *R1 .004 (2) .006
```

```
END
```

The next example illustrates the use of system elements to represent a nonlinear coupled system of differential equations in the time variable. The equation system involving the dependent variables $f(t)$, $g(t)$, and $v(t)$ is given by:

$$f' = (p_2 - v)g$$

$$g' = (p_1 - v)f - 2g/t$$

$$g'' = v - 2v'/t - 2(f^2 + g^2)$$

where $0 \leq t \leq 2$
 $f(0) = 1.8$
 $g(0) = 0$
 $v(0) = 7$
 $v'(0) = 0$
 $p_1 = 15$
 $p_2 = 1$

In the above notation $f' = df/dt$, etc. We note that there is an indeterminate form of $0/0$ for $t = 0$ in the equations for g' and g'' . The solution of the equations is well behaved at $t = 0$, and we can avoid the apparent singularity with no appreciable effect on the solution accuracy by replacing t with $t + \epsilon$ whenever t occurs in the denominator of these equations (ϵ is chosen to be arbitrarily small, positive, and nonzero).

This system of equations can be solved in simultaneous fashion using a network of system elements. Let us assign a value of $1E-6$ to ϵ and associate nodes with variables as follows:

<u>Variable</u>	<u>Node</u>
$f(t)$	F
$f'(t)$	DF
$g(t)$	G
$g'(t)$	DG
$v(t)$	V
$v'(t)$	DV
$v''(t)$	DDV

The network which corresponds to the system of equations is shown in Figure 11-1.

The NET-2 description of this network is:

```
*NONLINEAR EQUATION SYSTEM
INT1 DDV DV 1
INT2 DV V 1, 7
GAIN1 DV 1 2/(TIME+1E-6)
SUM1 DDV V -1 3
INT3 DF F 1, 1.8
MULT1 FSQ F F
SUM2 2 FSQ GSQ
INT4 DG G 1
MULT2 GSQ G G
SUM3 4 -V P2
MULT3 DF 4 G
GAIN3 G 7 2/(TIME+1E-6)
SUM4 5 V P1
MULT6 6 F 5
SUM5 DG 6 -7
V1 P1 0 15
V2 P2 0 1
GAIN2 2 3 -2
STATE1
  TIME 0 (100) 2
  PLOT N(V)
  PLOT N(G)
  PLOT N(F)
END
```

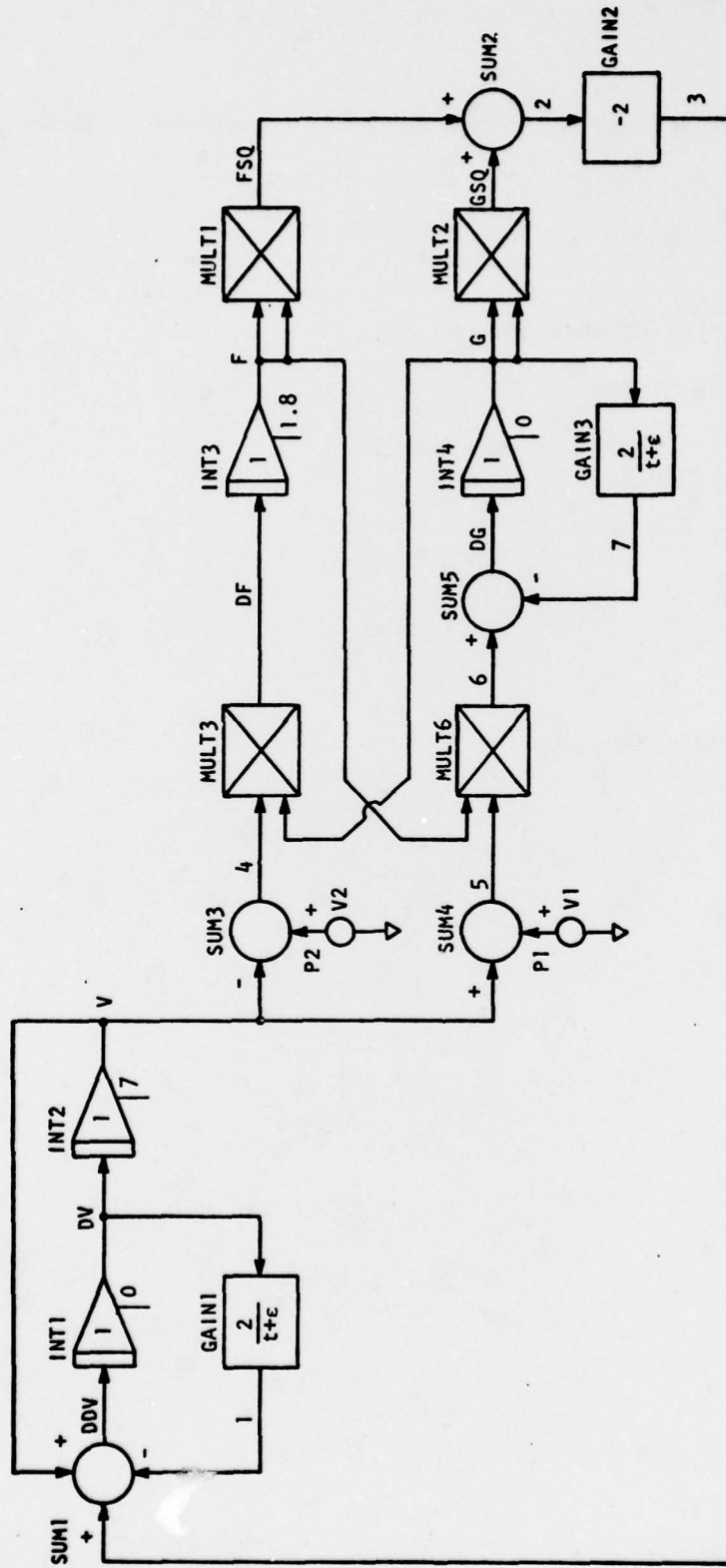

Figure 11-1. Nonlinear Coupled Differential Equation System

The final example illustrates the various ways in which mathematical expressions may be used in NET-2. The example is self consistent but does not represent a meaningful physical situation and is not intended to be run on NET-2. Note that TABLE6 is defined twice, once for model KB and once for the rest of the circuit description. The listing for this example is:

```

*MATHEMATICAL EXPRESSION EXAMPLE
MODEL KB A B
  TABLE6
    5 3
    7 1
  X1=TABLE6(TIME)*COS(TIME)/ALOG(SQRT(FREQ**(4433**(7+5/TABLE6(FREQ))))
  F9(A,C24)=SIN(45*FREQ**A+C24/6+3.97)
  WT3 A 2
  R5 2 3 I(WT3.V5)
  L1 B 2 X1+13*S3*F9(R5,I9)*L1*C7**2
  C7 A 2 N(WT3.7)/N(WT3.D)+N(WT3.C)
  S3 B 2 ABS(X1)
MODEL WT C D
  P2 -3
  R3 7 D U(I3/V5)*TAN(I3)/ATAN(3*P2+I3)
  I3 C D EXP(TIME)
  V5 D 7 R3E7
KB2 2 5
L3 5 KB2.WT3.C 39
K6 L3 KB2.L1 X1/R20+R2
F3=TIME+L3*ABS(COS(ABS(L3)+7))
F9(A,B,C,D)=A*B-C/D
R1 2 0 F9(TABLE6(F(L3)),2,R20,P2)**TABLE6(R2)
R20 5 0 3*R2
TERMINATE=TIME/2-100*P2
MAXSTEP=TABLE6(TIME)
OPTIMIZE2
  STATE
    OBJ=R2/P2+7 VS CURVE2
    L3=SQRT(R3)
  R3 1 12
TABLE6
  1 2
  4 3
P2 -5
R2 1 2 6
R3 1 0 7
R20 1 5 7E3
CURVE2
  0 5
  50 6
END

```

REFERENCES

1. A.F. Malmberg and F.L. Cornwell, "NET-1 Network Analysis Program," Report LA-2853, Los Alamos Scientific Laboratory, Los Alamos, N.M.
2. A.F. Malmberg, F.L. Cornwell, and F.N. Hofer, "NET-1 Network Analysis Program, 7090/94 Version," Report LA-3119, Los Alamos Scientific Laboratory, Los Alamos, N.M. (1964).
3. E.D. Johnson, L.R. McMurray, E.L. Steele, C.T. Kleiner, and F.A. Vassallo, "Transient Radiation Analysis by Computer Program (TRAC), Volume I, User's Guide," Autonetics Division of North American Rockwell Corporation, Anaheim, California (1968).
4. E.D. Johnson, L.R. McMurray, C.T. Kleiner, and F.A. Vassallo, "Transient Radiation Analysis by Computer Program (TRAC), Volume II, Theory and Flow Graphs," Autonetics Division of North American Rockwell Corporation, Anaheim, California (1968).
5. John G. Linvill, "Lumped Models of Transistors and Diodes," Proc. IRE, Volume 46, No. 6, pp. 1141-1152 (June 1958).
6. M.E. Daniel, "Development of Mathematical Models of Semiconductor Devices for Computer-Aided Circuit Analysis," Proc. IEEE, Volume 55, No. 11, pp. 1913-1920 (Nov. 1967).
7. L.D. Milliman, W.A. Massena, and R.H. Dickhaut, "CIRCUS, A Digital Computer Program for Transient Analysis of Electronic Circuits, User's Guide," Report 346-1, The Boeing Company, Seattle, Washington (January 1967).
8. J.L. Wirth and S.C. Rogers, "The Transient Response of Transistors and Diodes to Ionizing Radiation," IEEE Trans. on Nuclear Science, Vol. NS-11, pp. 24-38 (Nov. 1964).
9. W.H. Dierking, G.E. Katz, and E.L. Steele, "Transient Radiation Current Generator Model for Semiconductor Devices," Report X9-1294/571, Autonetics Division, North American Rockwell Corporation (1969).
10. Martin G. Buehler, "Design Curves for Predicting Fast-Neutron-Induced Resistivity Changes in Silicon," Proc. IEEE, pp. 1741-1743 (Oct. 1968).
11. M.C. Chow, J.L. Azarewicz, and C.A. Goben, "Recombination Statistics for Neutron Bombarded Silicon Transistors," IEEE Trans. on Nuclear Science, Vol. NS-15, No. 6 (1968).

12. L.S. Su, G.E. Gassner, and C.A. Goben, "Radiation and Annealing Characteristics of Neutron Bombarded Silicon Transistors," IEEE Trans. on Nuclear Science, Vol. NS-15, No. 6 (1968).
13. Joseph J. Kalinowski and Richard K. Thatcher, "TREE Handbook," DASA 1420, Battelle Memorial Institute (Sept. 1969).
14. D. Nitzan and J.R. Herndon, "MTRAC - A Computer Program for Analysis of Circuits Including Magnetic Cores, Volume I, Computation, Program, and Application," Report 6, Stanford Research Institute, Menlo Park, California (June 1969).
15. D. Nitzan and J.R. Herndon, "MTRAC - A Computer Program for Analysis of Circuits Including Magnetic Cores, Volume II, Input Data and Program Listing," Report 6, Stanford Research Institute, Menlo Park, California (June 1969).
16. Allan F. Malmberg, "User's Manual, NET-2 Network Analysis Program," Braddock, Dunn and McDonald, Inc., El Paso, Texas (Sept. 1972).

APPENDIX A: FORTRAN LOGICAL UNIT ASSIGNMENTS

The FORTRAN logical unit numbers employed by NET-2 are listed below along with their function in the program. Any logical unit which is not required in a particular NET-2 run may be used in conjunction with the INPFL or OUTFL system elements (see 3.34 and 3.35). The IBM 360/370 version is not restricted to these unit numbers.

<u>Unit</u>	<u>Function</u>
1	Stored model library master copy. Used if MØDEL Entry included, stored model referenced, or LIBRARY Entry references stored model library.
3	Device parameter library master copy. Used if modeled device specified in network or LIBRARY Entry references device parameter library.
4	Output data file. Always used.
5	Input file containing network description deck. Always used.
6	Output file containing NET-2 printed output information. Always used.
7	Reserved for punch output file in IBM 360/370 version. Not available in CDC 6000 version.
8	Internal file for dynamic storage allocation. Always used.
9	Device parameter library internal working file. Always used when unit 3 is used.
10	User specified copy of stored model library. Always used when LIBRARY Entry includes a CØPY Entry for the stored model library.
11	User specified copy of device parameter library. Always used when LIBRARY Entry includes a CØPY Entry for the device parameter library.

APPENDIX B: SPECIAL WORDS AND PREFIXES IN NET-2

The following words have special meaning to NET-2 and may not be used as names for subnetworks. However, they may be freely used for node names and function dummy arguments, and they may be included in the text for comments. A reference to the section number in this report is given for those words which are currently operational.

ABS	3.5
ACØS	3.18
ALL	9.1.1, 9.1.5
AND	3.30
ASIN	3.17
ATAN	3.19
C	2.3
CASES	7.2.4
CCNV	2.28
CØPY	9.1.4, 9.1.7
CURVE	8.2
CW	2.21
D	2.15
DATA	9.1.2.1
DDACC	3.37
DEBUG	1.2.2.7, 10.6
DEFINE	4.
DELAY	3.27
DELETE	9.1.3, 9.1.6
DERIV	3.11
DF	2.26
DIST	7.1
END	10.7
EØR	3.32
EXP	3.14
EXPN	3.15
F	1.2.2.6
FREQ	1.4.1
GAIN	3.2
GAMDØT	1.3.4.1
GAMMA	1.3.4.1
HC	2.23
HD	2.25
HYST	3.29
I	2.10
INITIAL	Reserved
INPFL	3.35
INT	3.10
IPP	2.13
JFET	2.20
K	2.6

L	2.5
LIBRARY	9.
LIM	3.21
LIMINT	3.22
LØG	3.13
MAX	3.7
MAXSTEP	1.3.2.1
MC	2.22
MFET	2.19
MIN	3.8
MINSTEP	Reserved
MØD	3.25
MØDEL	5.
MØNTECARLØ	7.
MULT	3.3
NEUT	1.3.4.2
NLVCCS	2.12
NØRM	3.24
ØBJ	8.1.3.1
ØPTIMIZE	8.
ØR	3.31
ØUTFL	3.34
P	1.2.2.3
PARAMETER	1.2.3.1
PLØT	6.1.4.2, 7.2.2
PN	2.27
PRINT	6.1.4.1, 7.2.2, 9.1.1, 9.1.5
QUANT	3.26
R	2.1
RADC	2.4
RMS	3.38
RNGEN	3.23
RSTFF	3.33
S	2.7
SAMPL	3.28
SCR	Reserved
SET	Reserved
SIGN	3.6
SINCØS	3.16
SNCLK	3.36
SQRT	3.4
ST	2.24
STATE	6., 8.1.3
SUM	3.1
T	2.18
TABF	3.9
TABLE	1.2.2.4.4
TANH	3.20
TD	2.17
TERMINATE	1.3.3

TIME	1.3.1
TLIM	10.6
TLINE	2.14
V	2.8
VCCS	2.11
VCG	2.2
VCVS	2.9
X	1.2.2.5
XFCP	3.12
XFCZCP	3.12
XFCZDP	3.12
XFP	3.12
XFSP	3.12
XFZCP	3.12
XFZP	3.12
XMØD	Reserved
YMØD	Reserved
ZD	2.16

DISTRIBUTION LIST

Commander in Chief
Continental Air Defense Command
ENT AFB
Colorado Springs, Colorado 80912
ATTN: DCS/C&E (CESA)

Defense Civil Preparedness Agency
Washington, D. C. 20301
ATTN: TS(AED), Room 1C 535

Director
Defense Communications Agency
Washington, D. C. 20305
ATTN: Code 470
Code 540.5
Code 962, LTC James M. Johnson
Code H810, James W. Mclean
Code 350, Mr. Joseph A. Kreck
Code 931, Monte I. Burgett, Jr.
Code 350, Nicholas A. Sica
Code 340, Mr. William H. Dix

Defense Documentation Center
Cameron Station, 5010 Duke Street
Alexandria, Virginia 22314
ATTN: TC (2 copies)
DDC-TCA (12 copies)

Director
Defense Intelligence Agency
Washington, D. C. 20301
ATTN: DI-7D, Mr. Edward O'Farrell
DTICI, Robert I. Rubinstein

Director
Defense Nuclear Agency
Washington, D. C. 20305
ATTN: DDST, Mr. Peter H. Haas
2 CY APTL, Technical Library
RAEV
STVL
APSI (Archives)

Commander
Field Command
Defense Nuclear Agency
Kirtland AFB, New Mexico 87115
ATTN: FCTA-C

Chief
Livermore Division, Field Command DNA
Lawrence Livermore Laboratory
P.O. Box 808
Livermore, California 94550
ATTN: Document Control for L-395

Director
National Security Agency
Ft. George G. Meade, Maryland 20755
ATTN: O. O. Van Gunten - R-425

Office of Joint Chiefs of Staff
Washington, D. C. 20301
ATTN: J-6 ESD-2
J-5 Plans and Policy (R&D Division)

Assistant Chief of Staff for
Communications-Electronics
Department of the Army
Washington, D. C. 20314
ATTN: CEED-7, Mr. Wesley T. Heath, Jr.

Chief of Research and Development
Department of the Army
Washington, D. C. 20310
ATTN: DARD-DDM

Commander
Harry Diamond Laboratories
Washington, D. C. 20438
ATTN: AMXDO-EM, Mr. Ron Bostak
AMXDO-EM, Mr. R. Wong
AMXDO-RBF, Dr. Robert Oswald, Branch 270
AMXDO-RB, Dr. Edward E. Contrad, Chief Lab 200
AMXDO-TI, Technical Library
AMXDO-RBG, Mr. Robert E. McCoskey Chief, BR-280
AMXDO-NP, Mr. F. Wimenitz, Chief NWEPC
AMXDO-NP, Mr. Stuart Marcus
AMXDO-RBF, Mr. John Rosado
AMXDO-EM, J. R. Miletta
AMXDO-EM, M. D. Calderazzo
AMXDO-EM, Mr. Adam F. Renner
Technical Reports Branch, 013
Library (2 copies)

Commander
Redstone Scientific Information Center
U.S. Army Missile Command
Redstone Arsenal, Alabama 35809
ATTN: Chief, Documents

Commander
Safeguard Communications Agency
Special Scientific Activities Directorate
Fort Huachuca, Arizona 85613
ATTN: SCCX-SSA

Commander
Safeguard System Evaluation Agency
White Sands Missile Range, New Mexico 88002
ATTN: SSEA-EAB (Francis N. Winans)

Commander
Safeguard System Site Activation Command
Grand Forks
P. O. Box 631
Langdon, North Dakota 58249
ATTN: Chief Activation Division

Commander
U.S. Army Aberdeen Research and Development Center
Aberdeen Proving Ground, Maryland 21005
ATTN: AMXRD-BVL, J. H. McNeilly

Commander
U.S. Army Air Defense Command
ENT AFB
Colorado Springs, Colorado 80912
ATTN: ADGEP, Mr. Barnes

Chief
U.S. Army Communications Systems Agency
Fort Monmouth, New Jersey 07703
ATTN: SCCM-AD-SV (Library)

Commander
U.S. Army Electronics Command
Fort Monmouth, New Jersey 07703
ATTN: AMSEL-NL-D
AMSEL-TL-IR, Dr. Edwin T. Hunter
AMSEL-GG-TD, W. R. Werk
AMSEL-TL-NT, Dr. H. A. Bomke
AMSEL-WL-D
AMSEL-TL-ME, Mr. M. W. Pmerantz

Commander
U.S. Army Electronics Proving Ground
Fort Huachuca, Arizona 85613
ATTN: STEEP-MT-M, Mr. Durbin

Division Engineer
U.S. Army Engineer District, Missouri River
P.O. Box 103 Downtown Station
Omaha, Nebraska 68101
ATTN: MRDED-MC, Mr. Floyd L. Hazlett, R&I Coord.

Headquarters
U.S. Army Europe and Seventh Army
APO New York 09403
ATTN: ODCSE-E, AEAGE-PI

Commander
U.S. Army Foreign Science and Technology Center
220 7th Street NE
Charlottesville, Virginia 22901
ATTN: AMXST-ISI (Mr. D. McCallum)

Commander
U.S. Army Materials & Mechanics Research Center
Watertown, Massachusetts 02172
ATTN: AMXMR-HH, Mr. John Dignam

Commander
U.S. Army Materiel Command
5001 Eisenhower Avenue
Alexandria, Virginia 22304
ATTN: AMCRD-WN, Mr. John J. F. Corrigan
AMCDL

Commander
U.S. Army Missile Command
Redstone Arsenal
Huntsville, Alabama 35809
ATTN: AMCPM-MD, SAM-D Project Manager
AMCPN-PE-EA, Mr. Scott D. Cozby
AMCPM-MDEI, CPT Joe A. Sims
AMSMI-RGP, Mr. Hugh Green
AMCPM-LCES, Howard Henbiksen
AMSMI-RGP, Mr. Vic Ruwe

Commander
U.S. Army Mobility Equipment R and D Center
Fort Belvoir, Virginia 22060
ATTN: STSFB-HHD, Mr. F. P. Good
STSFB-XN, Mr. W. J. Hass
STSFB-RN, D. B. Dinger
STSFB-MW, Dr. J. W. Bond

Commander
U.S. Army Munitions Command
Picatinny Arsenal
Dover, New Jersey 07801
ATTN: NDB 300, Bldg. 95, Arthur Nichols

Commander
U.S. Army Nuclear Agency
Fort Bliss, Texas 79916
ATTN: CDCNU-W

Chief
U.S. Army Nuclear and Chemical Surety Group
Bldg. 2073, North Area
Fort Belvoir, Virginia 22060
ATTN: FDSG-ND, Bldg. 2073, North Area

Commander
U.S. Army Picatinny Arsenal
Dover, New Jersey 07801
ATTN: SMUPA-NC-W, Philip Zirkind
SMUPA-TS-I-E, A. Grinoch
SMUPA-ND-D-C-2
Hyman Posternak
SMUPA-ND-C-S, Dr. Amina Nordic
SMUPA ND-N-E

Commander
U.S. Army Safeguard System Command
P. O. Box 1500
Huntsville, Alabama 35807
ATTN: SSC-DEM
SSC-STE

Commander
U.S. Army Strategic Communications Command
Fort Huachuca, Arizona 85613
ATTN: Safeguard Communications Agency, J. MCADOO

Commander
U.S. Army Tank Automotive Command
Warren, MI 48089
ATTN: AMCPM-GCM-SW, L. A. Wolcott

Commander
U.S. Army Test and Evaluation Command
Aberdeen Proving Ground, Maryland 21005
ATTN: AMSTE-NB, R. R. Galasso
AMSTE-EL, R. I. Kolchin

Commander
White Sands Missile Range
White Sands Missile Range, New Mexico 88002
ATTN: STENS-TE-N, Mr. Marvin P. Squires

Chief of Naval Operations
Navy Department
Washington, D. C. 20350
ATTN: OP-621E, Robert A. Blaise

Chief of Naval Research
Department of the Navy
Arlington, Virginia 22217
ATTN: Code 418, Dr. T. P. Quinn
Code 427

Commanding Officer
Naval Ammunition Depot
Crane, Indiana 47522
ATTN: Code 7024, Mr. James L. Ramsey

Commander
Naval Electronic Systems Command
Headquarters
Washington, D. C. 20360
ATTN: Code 05124, Bert Fox
PME 117-T

Commander
Naval Electronics Laboratory Center
San Diego, California 92152
ATTN: Code 3100, Mr. E. E. McCown

Commanding Officer
Naval Intelligence Support Center
4301 Suitland Road
Washington, D. C. 20390
ATTN: NISC-41

Commander
Naval Ordnance Laboratory
White Oak, Silver Spring, Maryland 20910
ATTN: (6 CY) Technical Library & Info Srv Div
Code 121
Code 431, Mr. Edwin B. Dean

Commander
Naval Ordnance Systems Command
National Center Building 2
Washington, D. C. 20360
ATTN: ORD-0523, Mr. R. Lane
ORD-034C, Mr. S. Barham
NAVORD-05221A, Melvin B. Landis

Director
Naval Research Laboratory
Washington, D. C. 20375
ATTN: Code 2627, Doris R. Folen
Code 6633, James C. Ritter
Code 4004, Dr. E. L. Brancato
Code 6603F, Richard L. Statler

Commander
Naval Ship Engineering Center
Center Building
Prince Georges Center
Hyattsville, Maryland 20782
ATTN: Code 617402, Edward F. Duffy

Commander
Naval Weapons Center
China Lake, California 93555
ATTN: Code 753, Technical Library

Commanding Officer
Naval Weapons Evaluation Facility
Kirtland Air Force Base
Albuquerque, New Mexico 87117
ATTN: L. Oliver
Code ATG, Mr. Stanley

Commanding Officer
Navy Astronautics Group
Point Mugu, California 93042
ATTN: Mr. T. Smith

Director
Strategic Systems Project Office
Crystal Mall No. 3
Washington, D. C. 20390
ATTN: NSP-230, Mr. David Gold
SP-234, R. Coleman
SP 2701, Mr. John W. Pitsenberger, Branch Eng.

Commander
Aeronautical Systems Division, AFSC
Wright-Patterson AFB, Ohio 45433
ATTN: ASD-YH-EX, MAJ. R. Leverette

Commander
Aerospace Defense Command
ENT AFB, Colorado 80912
ATTN: DEEDS, Joseph C. Brannan

Aerospace Research Laboratories, AFSC
Wright-Patterson AFB, Ohio 45433
ATTN: ARL/LS-2
ARL/LS, Y. S. Park

AF Armament Laboratory, AFSC
Eglin AFB, Florida 32542
ATTN: DLOSL - LIB

AF Institute of Technology, AU
Wright-Patterson AFB, Ohio 45433
ATTN: ENP, Dr. Charles J. Bridgman

AF Weapons Laboratory, AFSC
Kirtland AFB, New Mexico 87117
ATTN: SUL Technical Library
ELC
SAB
EL
ELP, MAJ. Walker
ELA
ELP, Dr. Carl Baum

AFTAC/TAE
Patrick AFB, Florida 32925
ATTN: TND
TAE

Air Force Avionics Laboratory, AFSC
Wright-Patterson AFB, Ohio 45433
ATTN: AFAL (TEA), Dr. Hans J. Hennecke
AFAL(NVS), Mr. Robert Conklin

Chief of Staff
U.S. Air Force
Washington, D. C. 20330
ATTN: RDQPN (S/V & Nuclear Programs Division)

Headquarters
Electronic Systems Division, (AFSC)
L. G. Hansom Field
Bedford, Maryland 01730
ATTN: MCAE, LTC Davis Sparks
DCD/SATIN IV
YWES

Commander
Foreign Technology Division, AFSC
Wright-Patterson AFB, Ohio 45433
ATTN: PDTN, Mr. Ballard

Space and Missile Systems Organization
P.O. Box 92960
Worldway Postal Center
Los Angeles, California 90009
ATTN: I. J. Judy (IND)
SZH, CAPT Marion F. Schneider
SKT, Peter H. Stadler
RSSG, Guidance Control & Elect Div
RSP, System Defn. & Assessment, LTC Gilbert
DYS (MAJ Heilman)
SZJ CAPT E. T. Dejonckheere, Jr.
DYJB, CAPT Glenn Ingram

Commander in Chief
Strategic Air Command
Offutt AFB, Nebraska 68113
ATTN: NRI-STINFO LIBRARY

Los Alamos Scientific Laboratory
P.O. Box 1663
Los Alamos, New Mexico 87544
ATTN: Document Control for J. Arthur Freed
Document Control for Donald R. Westervelt
Document Control for Bruce W. Noel
Document Control for Terry R. Gibbs, WX-7
Document Control for Dr. John S. Malik

Sandia Laboratories
P.O. Box 5800
Albuquerque, New Mexico 87115
ATTN: Document Control for Dennis L. Mangan, 2115
Document Control for ORG. 1935, J. E. Gover
Document Control for ORG. 2110, J. A. Hood
Document Control for J. A. Cooper, 2126
Document Control for ORG. 5223, C. N. Vittitoe
Document Control for Technical Library
Document Control for Albert A. Limieux
Document Control for ORG. 9353, R. L. Parker

Sandia Laboratories
Livermore Laboratory
P.O. Box 969
Livermore, California 94550
ATTN: J. A. Mogford, Div 8341
Kenneth A. Mitchell, 8157

University of California
Lawrence Livermore Laboratory
P.O. Box 808
Livermore, California 94550
ATTN: Donald J. Meeker, L-153
L-24 Miles L. Loyd
Technical Information Department L-3
L-24 Hans Kruger
L-156 Robert A. Anderson
L-24 CDR Gerald A. Fulk
Joseph E. Keller, Jr.

Central Intelligence Agency
ATTN: RD/SI RM 5G48 HQ Bldg
Washington, D. C. 20505
ATTN: William A. Decker

Administrator
Defense Electric Power Administration
Department of Interior
Interior South Bldg. 312
Washington, D. C. 20240
ATTN: Document Control

Department of Commerce
National Bureau of Standards
Washington, D. C. 20234
ATTN: Judson C. French, Chief, Electron Tech Div

Federal Aviation Administration
Headquarters Security Branch, ASE-210
800 Independence Avenue, S.W.
Washington, D. C. 20591
ATTN: F. S. Sakate (RD 650)

National Academy of Sciences
2101 Constitution Avenue, N.W.
Washington, D. C. 20418
ATTN: Dr. R. S. Shane Nat Materials Advisory BO

National Aeronautics and Space Administration
Lewis Research Center
21000 Brookpark Road
Cleveland, Ohio 44135
ATTN: Library

Aerojet Electro-Systems Co. Div.
Aerojet-General Corporation
P.O. Box 296
Azusa, California 91702
ATTN: Thomas D. Hanscome, B170/D6711

Aerospace Corporation
P.O. Box 92957
Los Angeles, California 90009
ATTN: Nuclear & Environmental Staff, N. D. Stockwell
Mr. I. M. Garfunkel-Bldg 115, Rm 2076
Mark S. Cooper
Dr. C. B. Pearlston, Bldg A2, Rm 2020
Library
Dr. Jerry Comisar
Dr. William W. Willis
S. P. Bower
J. Benveniste
Off of Tech., Surviv. Dir (D.A. McPherson)

Analog Technology Corporation
3410 East Foothill Boulevard
Pasadena, California 91107
ATTN: John Joseph Baum

AVCO
Government Products Group
201 Lowell Street
Wilmington, Maryland 01887
ATTN: Research Library, A680, Room 2201

Battelle Memorial Institute
505 King Avenue
Columbus, Ohio 43201
ATTN: Richard K. Thatcher

Bell Aerospace Company
Division of Textron, Inc.
P.O. Box 1
Buffalo, New York 14240
ATTN: Martin A. Henry, Mail Stop F-11
Carl B. Schoch, Weapons Effects M.S. I-85

Bell Telephone Laboratories, Inc.
Mountain Avenue
Murray Hill, New Jersey 07974
ATTN: R. Sherman, Rm 2A-259
R. D. Taft, Room 2B-181
Mr. I. G. Durand
E. C. Snyder, Room WH-2B-170
Ronald F. Baruzzi, Rm 2B-182
Norman G. Ziesse, Rm 2D-192A
H. A. Jarrell, Room WH-2F-153

Bell Telephone Laboratories, Inc.
Interstate 85N
at Mt. Hope Church Road-Guilford Center
P.O. Box 21447
Greensboro, North Carolina 27420
ATTN: John L. Gilmer, 1J-207

Bendix Corporation, The
Aerospace Systems Division
3300 Plymouth Road
Ann Arbor, Michigan 48107
ATTN: R. H. Pizarek

Bendix Corporation, The
Research Laboratories Division
Bendix Center
Southfield, MI 48075
ATTN: Mgr., Program Devel., Mr. Donald J. Niehaus

Bendix Corporation, The
Navigation and Control Division
Teterboro, New Jersey 07608
ATTN: E. E. Lademann

Boeing Company, The
P.O. Box 3707
Seattle, Washington 98124
ATTN: H. W. Wicklein, M.S. 17#11
A. R. Lowrey M.S. 2R-00

Booz-Allen and Hamilton, Inc.
SED Division
106 Apple Street
New Shrewsbury, New Jersey 07724
ATTN: Frederick Newton

Braddock, Dunn and McDonald, Inc.
1920 Aline Avenue
Vienna, Virginia 22180
ATTN: J. J. Kalinowski

Braddock, Dunn and McDonald, Inc.
P.O. Box 8885, Station C
Albuquerque, New Mexico 87108
ATTN: Dr. Robert B. Buchanan

Brown Engineering Company, Inc.
Research Park
Huntsville, Alabama 35807
ATTN: David Lambert, M.S. 18
John M. McSwain, M.S. 18

Calspan Corporation
P.O. Box 235
Buffalo, New York 14221
ATTN: R. H. Dickhaut, Bldg 10, Rm 341

Charles Stark Draper Laboratory, Inc.
68 Albany Street
Cambridge, Maryland 02139
ATTN: Kenneth Fertig
Paul Kelly

Collins Radio Company
5225 C Avenue, N.E.
Cedar Rapids, Iowa 52406
ATTN: A. R. Langenfeld, Bldg 107-150
M. Lahr, Librarian, Bldg. 106-216

Computer Sciences Corporation
P.O. Box 530
6565 Arlington Blvd.
Falls Church, Virginia 22046
ATTN: Mr. John D. Illgen

Cutler-Hammer, Inc.
AIL Division
Comac Road
Deer Park, New York 11729
ATTN: Central Technical Files, Anne Anthony
Richard J. Mohr

Dikewood Corporation, The
1009 Bradbury Drive, S.E.
University Research Park
Albuquerque, New Mexico 87106
ATTN: L. Wayne Davis

Douglas Aircraft Corporation
3855 Lakewood Blvd.
Long Beach, California 90846
ATTN: Tech Lib. CL 290/36-84 Auto-Witten

E-Systems, Inc.
Greenville Division
P.O. Box 1056
Greenville, Texas 75401
ATTN: Library 8-51910

Effects Technology, Inc.
5383 Holister Avenue
Santa Barbara, California 93105
ATTN: Edward John Steele

EG&G, Inc.
Albuquerque Division
P.O. Box 10218
Albuquerque, New Mexico 87114
ATTN: Hilda H. Hoffman

Experimental and Mathematical Physics Consultants
P.O. Box 66331
Los Angeles, California 90066
ATTN: Thomas M. Jordan

Fairchild Camera and Instrument Corporation
464 Ellis Street
Mountain View, California 94040
ATTN: Security Dept. for 2-233 Mr. David K. Myers

Fairchild Industries, Inc.
Sherman Fairchild Technology Center
20301 Century Boulevard
Germantown, Maryland 20767
ATTN: William Metzger

Franklin Institute, The
20th Street and Parkway
Philadelphia, Pennsylvania 19103
ATTN: Ramie H. Thompson

Garrett Corporation
9851 Sepulveda Blvd.
Los Angeles, California 90009
ATTN: Robert Weir, Dept. 93-9

General Electric Company
Space Division
Valley Forge Space Center
P.O. Box 8555
Philadelphia, Pennsylvania 19101
ATTN: Radiation Eff. Lab., Mr. John L. Andrews
Larry Chasen
Joseph C. Peden, CCF 8301
J. P. Spratt, Room M9549

General Electric Company
Re-Entry & Environmental Systems Division
P.O. Box 7722
3198 Chestnut Street
Philadelphia, Pennsylvania 19101
ATTN: Ray E. Anderson, Room 5330A
Robert V. Benedict

General Electric Company
Ordnance Systems
100 Plastics Avenue
Pittsfield, Maryland 01201
ATTN: David Corman Mail No. 2171

General Electric Company
Aerospace Electronics Systems
French Road
Utica, New York 13502
ATTN: Mail Sta 624, Mr. Fred Nicotera
W. J. Patterson, OROP 233

General Electric Company
P.O. Box 1122
Syracuse, New York 13201
ATTN: Hmes, Bldg 1, Rm N1, J. R. Greenbaum
CSP 6-7, L. H. Dee

General Electric Company
AEG-TECH Info Center
Evendale Plant
Cincinnati, Ohio 45215
ATTN: John A. Ellerhorst, E 2

General Electric Company
Tempo-Center for Advanced Studies
816 State Street (P.O. Drawer QQ)
Santa Barbara, California 93102
ATTN: DASIAC (REF. File)
Dr. Royden R. Rutherford

General Research Corporation
P.O. Box 3587
Santa Barbara, California 93105
ATTN: Dr. Robert D. Hill

General Research Corporation
1501 Wilson Blvd., Suite 700
Arlington, Virginia 22209
ATTN: David K. Osias

Georgia Institute of Technology
Office of Research Administration
Atlanta, Georgia 30332
ATTN: Res and Sec Coordinator for Mr. Hugh Denny

Goodyear Aerospace Corporation
Arizona Division
Litchfield Park, Arizona 85340
ATTN: Mr. B. Manning

Grumman Aerospace Corporation
South Oyster Bay Road
Bethpage, New York 11714
ATTN: Dept 533, PT 35, J. Rogers

GTE Sylvania, Inc.
Electronics Systems Group - Eastern Division
77 A Street
Needham, Maryland 02194
ATTN: Elect. Syst. Div., Leonard L. Blaisdell
S/V Eng. Dept., J. A. Waldron
Librarian, Mr. C. Thornhill

GTE Sylvania, Inc.
189 B Street
Needham Heights, Maryland 02194
ATTN: D. P. Flood
A.S.M. Dept Mr. S. E. Perlman
H&V Group, Mario A. Nurefora
Comm Syst Div. Emil P. Motchok
Herbert A. Ullman

Harris Semiconductor
A Division of Harris-Intertype Corporation
P.O. Box 883
Melbourne, Florida 32901
ATTN: T. L. Clark, M.S.-4040
A. Corvan

Hazeltine Corporation
Pulaski Road
Green Lawn, New York 11740
ATTN: J. B. Colombo

Hercules, Inc.
Bacchus Plant
P.O. Box 98
Magna, Utah 84044
ATTN: 100K-26-W. R. Woodruff

Honeywell Incorporated
Radiation Center
2 Forbes Road
Lexington, Maryland 02173
ATTN: Technical Library

Honeywell Incorporated
Aerospace Division
13350 U.S. Highway 19
St. Petersburg, Florida 33733
ATTN: M.S. 724-5, Mr. James D. Allen, Adv. Dev.

Hughes Aircraft Company
Ground Systems Group
1901 West Malvern Avenue
Fullerton, California 92634
ATTN: Lib. Bldg 600, M.S. C-222

Hughes Aircraft Company
Space Systems Division
P.O. Box 92919
Los Angeles, California 90009
ATTN: Harold A. Boyte, Bldg 366, M.S. A1080
Edward C. Smith, Bldg 366, M.S. C624
William W. Scott, Bldg 366, M.S. A1080

Hughes Aircraft Company
Centinella Avenue and Teale Streets
Culver City, California 90230
ATTN: B. W. Campbell, M.S. 6-E110
Dr. Dan Binder, M.S. 6/D147
M.S. D157, Ken Walker
R&D Div. Dr. John Singletary, M.S. D157

ITT Research Institute
10 West 35th Street
Chicago, Illinois 60616
ATTN: Mr. Jack E. Bridges
I. Mindel

Institute for Defense Analyses
400 Army-Navy Drive
Arlington, Virginia 22202
ATTN: Classified Library

Intelcom Rad Tech
P.O. Box 81087
San Diego, California 92138
ATTN: James A. Naber
Leo D. Cotter
R. L. Mertz
Ralph Stahl
Dr. V. J. J. Van Lint

International Business Machines Corporation
Route 17C
Owego, New York 13827
ATTN: Mr. Fred C. Tietze, Dept L 99, Bldg 002A
Frank Frankovsky
William K. Mead, Dept L 99,/102-1

International Telephone and
Telegraph Corporation
500 Washington Avenue
Nutley, New Jersey 07110
ATTN: Defense-Space Group, Smts. Frank Johnson

ION Physics Corporation
South Bedford Street
Burlington, Maryland 01803
ATTN: Mr. C. Hauer
Mr. R. Evans
Dr. H. Milde

Johns Hopkins University
Applied Physics Laboratory
8621 Georgia Avenue
Silver Spring, Maryland 20910
ATTN: Mr. Peter E. Partridge
Leroy Walters, Jr.

Human Sciences Corporation
P.O. Box 7463
Colorado Springs, Colorado 80933
ATTN: Dr. Albert P. Bridges
W. Foster Rich
W. Ware
Orlando Lopez
N-Gamma Lab., Dr. Don Bryce
Dr. Frank H. Shelton

Litton Systems, Inc.
Guidance & Control Systems Division
5500 Canoga Avenue
Woodland Hills, California 91364
ATTN: R. W. Maughmer
Dr. Val J. Ashby, Bldg 31/MS 67
John P. Retzler

Litton Systems, Inc.
Data Systems Division
8000 Woodley Avenue
Van Nuys, California 91406
ATTN: Mr. Sam Sternbach, Data Systems Division

Lockheed Missiles and Space Company
3251 Hanover Street
Palo Alto, California 94304
ATTN: Dr. Clarence F. Kooi, Dept. 52-11, Bldg. 204
Tech Info Ctr, G. R. Evans 0-52-52, Bldg 201

Lockheed Missiles and Space Company, Inc.
P.O. Box 504
Sunnyvale, California 94088
ATTN: H. Schneemann Org. 81-62
Dept. 81-01, Bldg. 154, Mr. D. M. Tellep
Benjamin T. Kimura, Dept 81-14, Bldg 154
M-365, Dept 81-23, Bldg 154

LTV Aerospace Corporation
Vought Systems Division
P.O. Box 6267
Dallas, Texas 75222
ATTN: Technical Data Center

M.I.T. Lincoln Laboratory
P.O. Box 73
Lexington, Maryland 02173
ATTN: Leona Loughlin, Librarian

Martin Marietta Aerospace
Orlando Division
P.O. Box 5837
Orlando, Florida 32805
ATTN: Eng Library, Mrs. Mona C. Griffith Lib., MP-30
Mr. William W. Mras, MP-413
Jack M. Ashford, MP-537
William W. Gargaro, MP 537

Martin Marietta Corporation
Denver Division
P.O. Box 179
Denver, Colorado 80201
ATTN: Special Projects Mail 0130
J. E. Goodwin Mail 1620

Maxwell Laboratories, Inc.
9244 Balboa Avenue
San Diego, California 92123
ATTN: Dr. V. Fargo

McDonnell Douglas Corporation
2600 North Third Street
St. Charles, Maryland 63301
ATTN: Chester G. Polak E411-107-1-D2

McDonnell Douglas Corporation
P.O. Box 516
St. Louis, Missouri 63166
ATTN: Library

McDonnell Douglas Corporation
5301 Bolsa Avenue
Huntington Beach, California 92647
ATTN: Mr. Dallas Petty SafeGD./SPRIN. Dept GPJC10
J. Logna
Stanley Schneider
Paul H. Duncan
Raymond J. DeBattista

Mission Research Corporation
P.O. Box 8693, Station C
Albuquerque, New Mexico 87108
ATTN: Larry D. Scott
James R. Hill

Mission Research Corporation
735 State Street
Santa Barbara, California 93101
ATTN: William Hart
Dr. Conrad L. Longmire

Mitre Corporation, The
Route 62 and Middlesex Turnpike
P.O. Box 208
Bedford, Maryland 01730
ATTN: Theodore Jarvis

Mitre Corporation, The
2343 East Broadway
Tucson, Arizona 85719
ATTN: L. D. Bickmoke

Motorola, Inc.
Government Electronics Division
8201 East McDowell Road
Scottsdale, Arizona 85257
ATTN: Technical Inf. Center - A.J. Kordalewski

Northrop Corporation
Electronic Division
2301 West 120th Street
Hawthorne, California 90250
ATTN: John M. Reynolds

Northrop Corporation
Electronic Division
1 Research Park
Palos Verdes Peninsula, California 90274
ATTN: George H. Towner, Dept 6113, Bldg T30
T6114, V. Demartino
Boyce T. Ahlport

Northrop Corporation
Northrop Research and Technology Center
3401 West Broadway
Hawthorne, California 90250
ATTN: David N. Pocock
Library
Mr. James P. Raymond
Dir. Solid St. Elec. Dr. Orlie L. Curtis Jr.

Perkin-Elmer Corporation
Main Avenue
Norwalk, Connecticut 06856
ATTN: Thomas D. Jones, Jr.

Philco-Ford Corporation
Aerospace & Communications Operations
Aeronutronic Division
Ford & Jamboree Roads
Newport Beach, California 92663
ATTN: Dr. L. H. Linder
K. C. Attinger
E. R. Poncelet, Jr.

Philco-Ford Corporation
Western Development Laboratories Division
3939 Fabian Way
Palo Alto, California 94303
ATTN: J. T. Mattingly, M.S. X-22
Library
D. R. McMorrow M/S G30

Physics International Company
2700 Merced Street
San Leandro, California 94577
ATTN: Document Control for Dr. Frank Ford

Pulsar Associates, Inc.
7911 Herschel Avenue
La Jolla, California 92037
ATTN: Carleton Jones

R & D Associates
P.O. Box 3580
Santa Monica, California 90403
ATTN: Mr. Richard R. Schaefer
Mr. Robert A. Poll
Dr. William R. Graham
Dr. William J. Karzas
Mr. S. Clay Rogers

Rand Corporation, The
1700 Main Street
Santa Monica, California 90406
ATTN: Dr. Cullen Crain

Raytheon Company
528 Boston Post Road
Sudbury, MA 01776
ATTN: Harold L. Flescher
J. R. Weckback

Raytheon Company
Hartwell Road
Bedford, MA 01730
ATTN: Gajanan Joshi, Radar Systems Lab

RCA Corporation
Camden Complex
Front & Cooper Streets
Camden, New Jersey 08102
ATTN: E. Van Keuren 13-5-2

RCA Corporation
Government & Commercial Systems
Astro Electronics Division
P.O. Box 800, Locust Corner
Princeton, New Jersey 08540
ATTN: Dr. George Brucker

RCA Corporation
Government & Commercial Systems
Missile & Surface Radar Division
Marne Highway and Borton Landing Road
Moorestown, New Jersey 08057
ATTN: Mrs. Eleanor Daly
Mr. A. L. Warren

Research Triangle Institute
P.O. Box 12194
Research Triangle Park, North Carolina 27709
ATTN: Eng. Div. Dr. Mayrant Simons, Jr.

Rockwell International Corporation
4300 East Fifth Avenue
Columbus, Ohio 43216
ATTN: Engineering Data Services (J. F. Roberts)

Rockwell International Corporation
5701 West Imperial Highway
Los Angeles, California 90009
ATTN: Donald J. Stevens, BB33
T. B. Yates, BA08
TIC, BA08

Rockwell International Corporation
3370 Miroloma Avenue
Anaheim, California 92803
ATTN: J. F. Sexton, CA31
J. Bell, HA 10
R. A. Hubbs, FB 46

Sanders Associates, Inc.
95 Canal Street
Nashua, New Hampshire 03060
ATTN: James L. Burrows, Rm 3236
I-6270, R. G. Despathy Sr, P.E.
M. L. Aitel
Jack Schwartz

Science Applications, Inc.
P.O. Box 2351
La Jolla, California 92037
ATTN: Dr. J. Robert Beyster
Dr. R. Parkinson

Science Applications, Inc.
Huntsville Division
2109 West Clinton Avenue
Suite 700
Huntsville, Alabama 35805
ATTN: Noel R. Byrn

Singer Company, The
M/S 12-5820
150 Totowa Road
Wayne, New Jersey 07470
ATTN: Dr. A. A. Witteles - M/S 12-5820

Sperry Rand Corporation
Sperry Gyroscope Division
Great Neck, New York 11020
ATTN: Paul Marraffino
Mr. C. Craig, EV

Sperry Rand Corporation
Univac Division
Defense Systems Division
P.O. Box 3525 Mail Station 1931
St. Paul, Minnesota 55101
ATTN: Mr. J. A. Inda, M.S. 5451

Sperry Rand Corporation
Sperry Flight Systems Division
P.O. Box 21111
Phoenix, Arizona 85027
ATTN: D. A. Schow, Room 104C

Stanford Research Institute
306 Wynn Drive, N.W.
Huntsville, Alabama 35805
ATTN: Harold Carey

Stanford Research Institute
333 Ravenswood Avenue
Menlo Park, California 94025
ATTN: Mr. Arthur Lee Whitson
William C. Taylor
Mr. Philip Dolan
Dr. Robert A. Armistead

Sundstrand Corporation
4751 Harrison Avenue
Rockford, Illinois 61101
ATTN: Dept 763SW, Curt White

Systron-Donner Corporation
1090 San Miguel Road
Concord, California 94518
ATTN: Harold D. Morris

Texas Instruments, Inc.
P.O. Box 5474
Dallas, Texas 75222
ATTN: R&D Proj. Man., Dr. Donald J. Manus, M.S. 72
Rad Effects Prog Mgr, Mr. Gary F. Hanson

Texas Tech University
P.O. Box 5404 North College Station
Lubbock, Texas 79417
ATTN: Travis L. Simpson

TRW Systems Group
One Space Park
Redondo Beach, California 90278
ATTN: Dr. R. D. Jortner
Mr. R. Kingsland, R1-2154
Dr. A.M. Liebschutz, R1-2154
Robert M. Webb, M.S. R1-1071
Jerry I. Lubell
Arron H. Narevsky, R1-2144
William H. Robinette Jr.
Robert M. Webb, M.S. R1-1071
Dr. Lillian Singletary R1/1070
Technical Information Center/S-1930

TRW Systems Group
San Bernardino Operations
P.O. Box 1310
San Bernardino, California 92402
ATTN: E. W. Allen
J. E. Dahnke
H. S. Jensen

United Aircraft Corporation
Hamilton Standard Division
Bradley International Airport
Windsor Locks, CT 06069
ATTN: Raymond G. Gignere

University of Denver
Colorado Seminary
Denver Research Institute
University Park
Denver, Colorado 80210
ATTN: Security Officer for Mr. Fred P. Venditti

Westinghouse Electric Corporation
Research and Development Center
1310 Beulah Road, Churchill Borough
Pittsburgh, Pennsylvania 15235
ATTN: William E. Newell

Westinghouse Electric Corporation
Defense and Electronic Systems Center
P.O. Box 1693
Friendship International Airport
Baltimore, Maryland 21203
ATTN: Henry P. Kalapaca, M.S. 3525

Westinghouse Electric Corporation
Astronuclear Laboratory
P.O. Box 10864
Pittsburg, Pennsylvania 15236
ATTN: P. W. Dickson

REPORT DOCUMENTATION PAGE		READ INSTRUCTIONS BEFORE COMPLETING FORM
1. REPORT NUMBER HDL-050-1 /	2. GOVT ACCESSION NO.	3. RECIPIENT'S CATALOG NUMBER
4. TITLE (and Subtitle) NET-2 Network Analysis Program Release 9		5. TYPE OF REPORT & PERIOD COVERED User Manual
		6. PERFORMING ORG. REPORT NUMBER
7. AUTHOR(s) Allan F. Malmberg		8. CONTRACT OR GRANT NUMBER(s) DAAG39-70-C-0050
9. PERFORMING ORGANIZATION NAME AND ADDRESS Braddock, Dunn and McDonald, Inc. 6500 Convair Road El Paso, Texas 79925		10. PROGRAM ELEMENT, PROJECT, TASK AREA & WORK UNIT NUMBERS AMCMS Code: 691000.22.10714
11. CONTROLLING OFFICE NAME AND ADDRESS Harry Diamond Laboratories Washington, D. C. 20438		12. REPORT DATE September 1973
		13. NUMBER OF PAGES 234
14. MONITORING AGENCY NAME & ADDRESS (if different from Controlling Office)		15. SECURITY CLASS. (of this report) Unclassified
		15a. DECLASSIFICATION/DOWNGRADING SCHEDULE
16. DISTRIBUTION STATEMENT (of this Report) Approved for public release; distribution unlimited.		
17. DISTRIBUTION STATEMENT (of the abstract entered in Block 20, if different from Report)		
18. SUPPLEMENTARY NOTES		
19. KEY WORDS (Continue on reverse side if necessary and identify by block number) Network analysis, systems analysis, electronic circuit analysis, nuclear radiation effects, optimization, transient response, frequency response, computer program, NET-2		
20. ABSTRACT (Continue on reverse side if necessary and identify by block number) NET-2 is a general purpose computer program which solves the nonlinear time domain response and linearized frequency domain response of arbitrary networks composed of electric circuit elements and system operational elements. NET-2 performs parameter variation studies, statistical studies, and network performance optimization. Models are included for gamma rate and neutron dose radiation effects. A topological network description is utilized using a free form user oriented input language.		

SECURITY CLASSIFICATION OF THIS PAGE(When Data Entered)

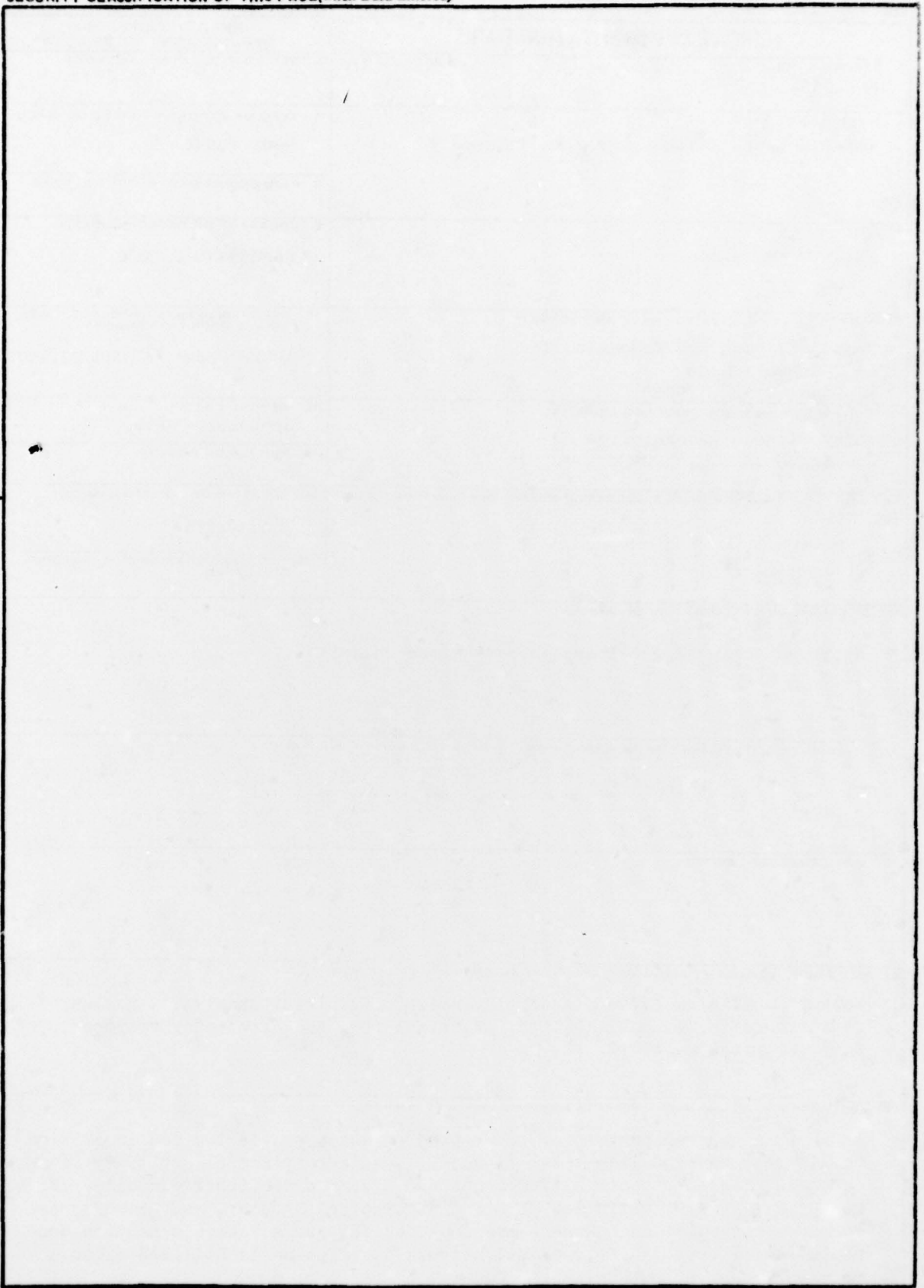

SECURITY CLASSIFICATION OF THIS PAGE(When Data Entered)