

AD-A079 049

GAI CONSULTANTS INC MONROEVILLE PA F/6 13/13
NATIONAL DAM INSPECTION PROGRAM. PA-657 DAM (ACME DAM) (NDI I.D--ETC(U)
JUN 79 B M MIHALCIN DACW31-79-C-0013

NL

UNCLASSIFIED

[1 of 1]
AD-A079 049



END
DATE
FILMED
2 80
EDC

6

ADA 079049

OHIO RIVER BASIN
JACOBS CREEK, WESTMORELAND COUNTY, Pennsylvania

6 National Dam Inspection Program

PA-657 DAM
(ACME DAM)

LEVEL

Number

(NDI ID. PA-00828
PENNDER ID. 65-133)

Number

PHASE I INSPECTION REPORT,
NATIONAL DAM INSPECTION PROGRAM

11

Jun 79

1287

ORIGINAL CONTAINS COLOR PLATES: ALL
REPRODUCTIONS WILL BE IN BLACK AND WHITE

10

Bernard M. Mihalcin

Distribution Unlimited
Approved for Public Release
Contract No./DACW31-79-C-0013

PREPARED FOR

DEPARTMENT OF THE ARMY
Baltimore District, Corps of Engineers
Baltimore, Maryland 21203

UDC FILE COPY

PREPARED BY

GAI CONSULTANTS, INC.
570 BEATTY ROAD
MONROEVILLE, PENNSYLVANIA 15146

DDC
RECEIVED
JAN 9 1980
REGISTRY
A

JUNE 1979

1 072

411 002

PREFACE

This report is prepared under guidance contained in the Recommended Guidelines for Safety Inspection of Dams, for Phase I investigations. Copies of these guidelines may be obtained from the Office of Chief of Engineers, Washington, D. C. 20314. The purpose of a Phase I investigation is to identify expeditiously those dams which may pose hazards to human life or property. The assessment of the general condition of the dam is based upon available data and visual inspections. Detailed investigation, and analyses involving topographic mapping, subsurface investigations, testing, and detailed computational evaluations are beyond the scope of a Phase I investigation; however, the investigation is intended to identify any need for such studies.

In reviewing this report, it should be realized that the reported condition of the dam is based on observations of field conditions at the time of inspection along with data available to the inspection team.

It is important to note that the condition of a dam depends on numerous and constantly changing internal and external conditions, and is evolutionary in nature. It would be incorrect to assume that the present condition of the dam will continue to represent the condition of the dam at some point in the future. Only through frequent inspections can unsafe conditions be detected and only through continued care and maintenance can these conditions be prevented or corrected.

Phase I inspections are not intended to provide detailed hydrologic and hydraulic analyses. In accordance with the established guidelines, the spillway design flood is based on the estimated "Probable Maximum Flood" for the region (greatest reasonably possible storm runoff), or fractions thereof. The spillway design flood provides a measure of relative spillway capacity and serves as an aid in determining the need for more detailed hydrologic and hydraulic studies, considering the size of the dam, its general condition, and the downstream damage potential.

PHASE I REPORT
NATIONAL DAM INSPECTION PROGRAM

ABSTRACT

PA-657 Dam (Acme Dam): NDI I.D. No. PA-00828

Owner: Westmoreland County Commissioners
State Located: Pennsylvania
County Located: Westmoreland
Stream: Jacobs Creek
Inspection Date: 4 May 1979
Inspection Team: GAI Consultants, Inc.
570 Beatty Road
Monroeville, Pennsylvania 15146

Based on a visual inspection, past performance, and available engineering data, the facility is considered to be in good condition. The size classification of the facility is intermediate and the hazard classification is considered to be high. The emergency spillway is capable of discharging the peak inflow resulting from a storm of PMF intensity and is, therefore, considered adequate.

It is recommended that the owner:

(a) Repair the damaged pond drain gate control and replace the missing manhole cover atop the service spillway riser. Consideration should be given to redesigning the gate control mechanism to protect it from future vandalism.

b) Consult with the U.S.D.A., Soil Conservation Service, to assess the erosion on the upstream slope in the area of the service spillway riser and implement any remedial measures deemed necessary.

c. Curtail the unauthorized vehicular travel across the embankment and repair and reseed any damaged (bare) areas. If control of unauthorized travel is not practical, some provision should be made to protect the embankment from rutting and erosion by placing a layer of gravel or stone across the crest.

d! Develop a formal operation and maintenance manual to ensure the continued proper care of the facility. In addition, a formal warning system should be implemented which provides detailed procedures to protect the lives and property of downstream residents. Included in the plan should be provisions for around-the-clock surveillance of the facility during periods of unusually heavy precipitation.

GAI Consultants, Inc.

Approved by:

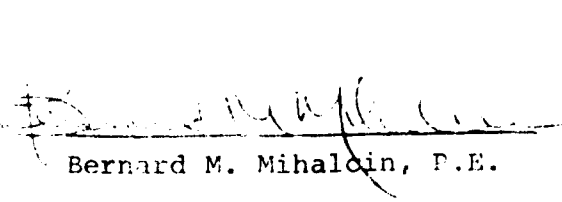

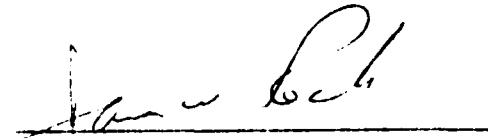
Bernard M. Mihalcin, P.E.

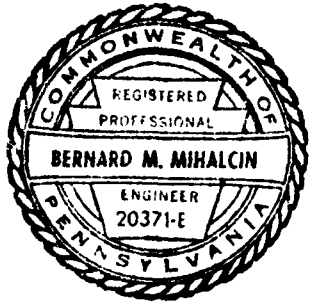
JAMES W. PECK
Colonel, Corps of Engineers
District Engineer

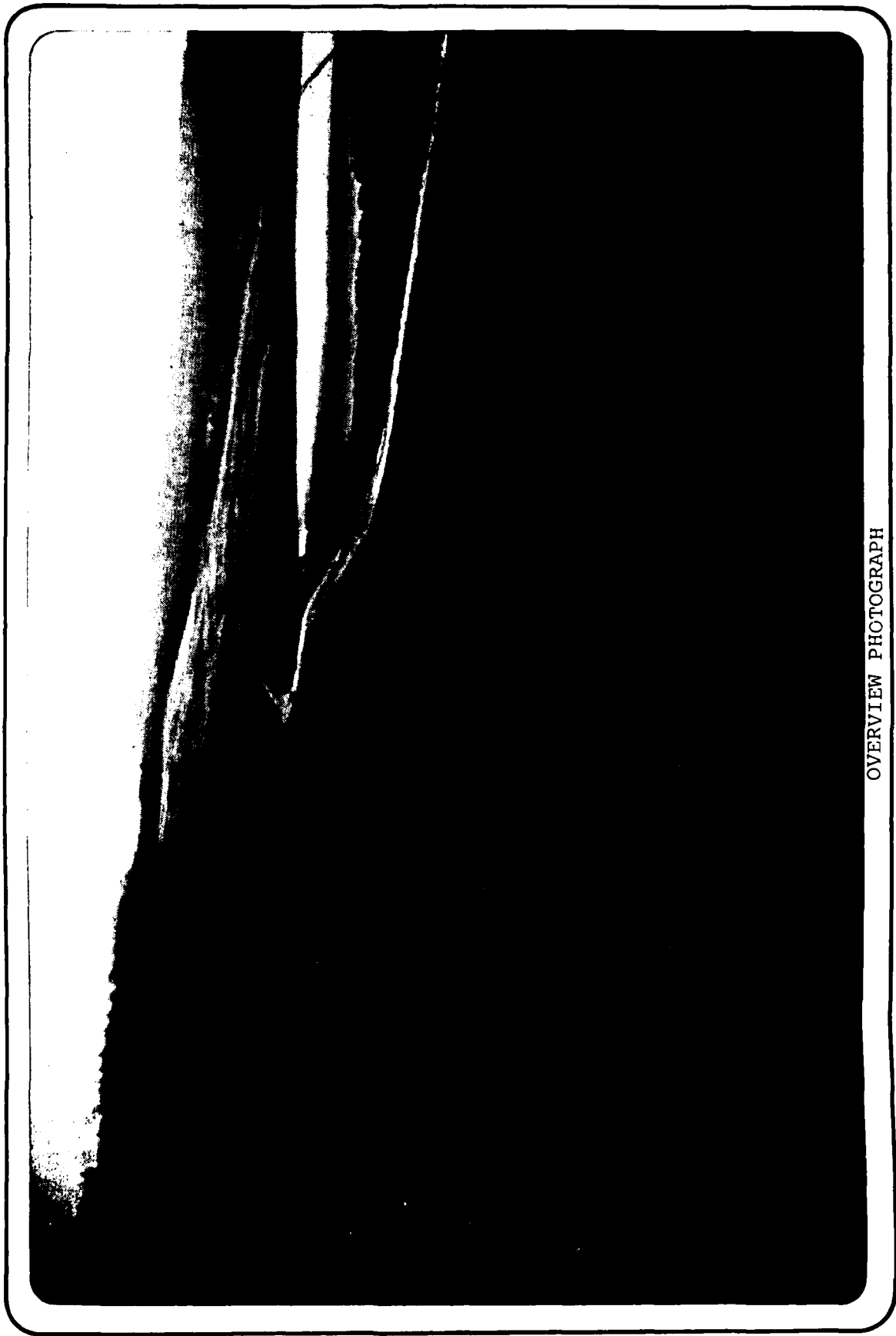

Date 11 Aug 1979

Date 13 August 1979



OVERVIEW PHOTOGRAPH

TABLE OF CONTENTS

	<u>Page</u>
PREFACE	i
ABSTRACT.	ii
OVERVIEW PHOTOGRAPH	v
TABLE OF CONTENTS	vi
SECTION 1 - GENERAL INFORMATION	1
1.0 Authority	1
1.1 Purpose	1
1.2 Description of Project.	1
1.3 Pertinent Data.	2
SECTION 2 - ENGINEERING DATA.	6
2.1 Design.	6
2.2 Construction Records.	8
2.3 Operational Records	8
2.4 Other Investigations.	8
2.5 Evaluation.	8
SECTION 3 - VISUAL INSPECTION	9
3.1 Observations.	9
3.2 Evaluation.	10
SECTION 4 - OPERATIONAL PROCEDURES.	11
4.1 Normal Operational Procedures	11
4.2 Maintenance of Dam.	11
4.3 Maintenance of Operating Facilities	12
4.4 Warning Systems	12
4.5 Evaluation.	12
SECTION 5 - HYDROLOGIC/HYDRAULIC EVALUATION	13
5.1 Design Data	13
5.2 Experience Data	14
5.3 Visual Observations	14
5.4 Method of Analysis.	14
5.5 Summary of Analysis	14
5.6 Spillway Adequacy	15
SECTION 6 - EVALUATION OF STRUCTURAL INTEGRITY.	16
6.1 Visual Observations	16
6.2 Design and Construction Techniques.	16
6.3 Past Performance.	16
6.4 Seismic Stability	17
SECTION 7 - ASSESSMENT AND RECOMMENDATIONS FOR REMEDIAL MEASURES	18
7.1 Dam Assessment.	18
7.2 Recommendations/Remedial Measures	18

TABLE OF CONTENTS

APPENDIX A - CHECK LIST - ENGINEERING DATA
APPENDIX B - CHECK LIST - VISUAL INSPECTION
APPENDIX C - HYDROLOGY AND HYDRAULICS
APPENDIX D - PHOTOGRAPHS
APPENDIX E - GEOLOGY
APPENDIX F - FIGURES
APPENDIX G - REGIONAL VICINITY AND WATERSHED BOUNDARY MAP

PHASE I INSPECTION REPORT
NATIONAL DAM INSPECTION PROGRAM
PA-657 DAM (ACME DAM)
NDI# PA-828, PENNDER# 65-133

SECTION 1
GENERAL INFORMATION

1.0 Authority.

The Dam Inspection Act, Public Law 92-367, authorized the Secretary of the Army, through the Corps of Engineers, to initiate a program of inspection of dams throughout the United States.

1.1 Purpose.

The purpose is to determine if the dam constitutes a hazard to human life or property.

1.2 Description of Project.

a. Dam and Appurtenances. PA-657 Dam, locally known as Acme Dam, is an earth embankment approximately 500 feet in length with a maximum field measured height of 33 feet. The structure is essentially a standard U. S. Department of Agriculture, Soil Conservation Service (SCS) design and is equipped with both service and emergency spillways (see Overview Photograph and Figure 3). The service spillway is located on the upstream face near the center of the embankment. It is a single-stage, reinforced concrete drop inlet, vertical riser connected to a 30-inch diameter, horizontal concrete conduit at its base. The emergency spillway is a vegetated earth channel of trapezoidal cross-section with a base width of 100 feet excavated in the left abutment. The facility is provided with a pond drain consisting of a 16-foot long section of 18-inch diameter reinforced concrete pipe with intake at the upstream toe and discharge outlet at the base of the service spillway riser (see Figures 7 and 8).

b. Location. PA-657 Dam is located across Jacobs Creek in Mount Pleasant Township, Westmoreland County, Pennsylvania. The community of Acme, Pennsylvania, is located about one mile northwest of the facility along Pennsylvania Route 31, three miles west of Pennsylvania Turnpike Interchange 9 at Donegal, Pennsylvania. The dam, reservoir, and watershed are contained within the Donegal,

Pennsylvania, U.S.G.S. 7.5 minute topographic quadrangle (see Appendix G). The coordinates of the dam are N40° 7.8' and W79° 25.4'.

c. Size Classification. Intermediate (33 feet high, 1,540 acre-feet total storage capacity at top of dam).

d. Hazard Classification. High (see Section 3.1.e).

e. Ownership. Westmoreland County Commissioners
Court House
Greensburg, Pennsylvania 15601

f. Purpose of Dam. Recreation and flood retardation.

g. Historical Data. PA-657 Dam was designed by the U. S. Department of Agriculture, Soil Conservation Service, as part of a flood control system in the Jacobs Creek Watershed, which was to consist of three dams and a stream channel improvement project. Construction of the facility began in July 1972. Correspondence indicates that four contractors managed the project until it was finally completed in July 1975, by Five-R Excavating, Inc., from New Florence, Pennsylvania. No major modifications have been made to the structure since its completion. Plans to develop the area surrounding the facility into a park have not been finalized; however, boating and fishing are presently allowed. Thus, the facility currently is used for both flood control and recreation.

1.3 Pertinent Data.

a. Drainage Area (square miles). 2.6

b. Discharge at Dam Site. Daily records of reservoir levels and discharges are not recorded at this facility. The owner is obligated by contract with the SCS to inspect the facility annually and after major storms and to report on any damage incurred. An estimate of high water is usually included. Discussions with the local SCS representative, present during the inspection, indicated that, to this date, the emergency spillway has never discharged.

Discharge Capacity of the Service Spillway (pool at top of dam elevation 1844.1) \approx 120 cfs (design value).

Discharge Capacity of the Emergency Spillway (pool at top of dam elevation 1844.4) \approx 10,450 cfs (see Appendix C, Sheet 7).

c. Elevation (feet above mean sea level). The following elevations are based on available drawings by the U.S.D.A., Soil Conservation Service, dated 10-71. These elevations have been roughly verified by field measurements; however, no formal survey was performed (see Appendix F).

Top of Dam	1844.4 (field)
	1844.1 (design)
Maximum Design High Water	1838.2
Maximum Pool of Record	Not known
Normal Pool	1827.5
Service Spillway Crest	1827.5
Emergency Spillway Crest	1835.0
Pond Drain Upstream Invert	1815.6
Pond Drain Downstream Invert	1815.6
Streambed at Dam Center	1815.0
Streambed at Downstream Toe	1811.4 (field)
Maximum Tailwater	Not known

d. Reservoir Length (feet).

Top of Dam	5000
Normal Pool	3000

e. Storage (acre-feet).

Top of Dam	1540
Normal Pool	93
Emergency Spillway Crest	460
Design Surcharge	1080

f. Reservoir Surface (acres).

Top of Dam	145
Normal Pool	25
Emergency Spillway Crest	75

g. Dam.

Type	Zoned earth
Length	500 feet
Height	33 feet (field measured - crest to downstream toe)
Top Width	12 feet (field measured) 14 feet (design)

Upstream Slope	2.5H:1V
Downstream Slope	2.5H:1V
Zoning	Four zones described in detail on Figure 4.
Impervious Core	Zone I material; carried to elevation 1835.0; 1H:1V side slopes with a 10-foot top width.
Cutoff	Provided along embankment centerline; 1H:1V side slopes with a 12-foot bottom width.
Grout Curtain	None indicated.
h. <u>Pond Drain.</u>	
Type	18-inch diameter reinforced concrete pipe with intake at the upstream toe and discharge outlet at the base of the service spillway riser.
Length	16 feet
Closure	Provided by an 18-inch diameter slide gate mounted on the inside face of the service spillway riser.
Access	Located at the base of the service spillway riser, the pond drain is accessible through the riser itself. However, no ladder or other means of reaching the riser base is provided by the design.

i. Service Spillway.

Type	Single-stage, reinforced concrete, drop inlet, vertical riser connected to a 30-inch diameter reinforced concrete discharge conduit which discharges into a standard SCS reinforced concrete impact basin.
Crest Elevation	1827.5
Upstream Channel	Not applicable.
Downstream Channel	20-foot long, riprap-lined, trapezoidal-shaped channel.

j. Emergency Spillway.

Type	Unlined vegetated channel excavated in the left abutment.
Crest Elevation	1835.0
Channel Width	100 feet
Breadth of Control Section	30 feet
Upstream Channel	Curved, unlined channel with 2 percent slope.
Downstream Channel	Discharge from the emergency spillway is directed over the left abutment hillside and into the natural stream several hundred feet downstream of the embankment toe.

SECTION 2
ENGINEERING DATA

2.1 Design.

a. Design Data Availability and Sources.

1. Hydrology and Hydraulics. Hydrologic and hydraulic design data are contained within a comprehensive design report prepared by the SCS and available at their Harrisburg and Washington, Pennsylvania offices.

2. Embankment. Comprehensive design data are contained within the SCS report mentioned above.

3. Appurtenant Structures. Same as above.

b. Design Features. Available construction drawings and design data indicate that the dam is a zoned earthfill structure consisting of approximately 26,000 cubic yards of fill. The structure is comprised of four zones as shown in Figure 4.

Zone I is composed of impervious material placed at the core and carried up to elevation 1835.0. Zone II material is slightly more pervious and makes up the shells on either side of Zone I. The outer shells of the fill are composed of Zone III material which consists of sandstone excavated from the emergency spillway and oversized material raked from Zones I and II. Zone IV material consists of topsoil placed on the exposed outer slopes.

The plans indicate the embankment has been constructed with a cutoff trench located along the centerline of the embankment foundation. The design calls for the trench to have been excavated between Station 3+65 and Station 7+10 with 1H:1V side slopes and a 12-foot bottom width.

A drainage system has been designed under the downstream portion of the earth fill to control the phreatic line and seepage (see Figures 4 and 6).

2. Appurtenant Structures.

a) Service Spillway. The service spillway is a single-stage, drop inlet structure consisting of a reinforced concrete riser and a 30-inch diameter reinforced concrete discharge conduit (see Figures 7, 8, 9, and 10).

b) Emergency Spillway. The emergency spillway is a trapezoidal channel cut into the left abutment. The control section has a crest length of 100 feet and is 30 feet wide (see Figures 3 and 5).

c) Pond Drain. The lake can be drained via an 18-inch diameter reinforced concrete pipe that discharges into the base of the service spillway riser and ultimately through the 30-inch diameter discharge conduit. The pond drain is regulated by means of an 18-inch diameter slide gate mounted on the inside face of the riser and operated manually from atop the riser (see Figures 7 and 8).

c. Specific Design Data and Criteria.

1. Hydrology and Hydraulics. The hydrologic and hydraulic design of this facility was based on criteria, data, and methods established in the "National Engineering Handbook" of the U. S. Department of Agriculture, Soil Conservation Service. Specific data and criteria are listed in Section 5, herein.

2. Embankment. All aspects of the embankment design were prepared by the Soil Conservation Service. Available design information includes all the basic elements of earth dam design. Embankment materials and local soils classifications, moisture-density relationship, consolidation, permeability, and shear strength are all discussed in various memoranda and correspondence contained in SCS files.

Stability analysis was performed using the SCS stability computer program. The dam was analyzed with a center core section using total stress shear strength parameters of $\phi = 14.5^\circ$ and $C = 700$ psf and effective stress parameters of $\bar{\phi} = 33.5^\circ$ and $\bar{C} = 0$ psf. The shell section had shear parameters of $\phi = 35^\circ$ and $C = 0$ psf. Shear parameters of $\phi = 35.5^\circ$ and $C = 875$ psf were used for the surface 6 feet of the foundation.

No data were available that could confirm the above design parameters were indeed attained during construction.

A full drawdown analysis of the upstream 2.5H:1V slope with a 10-foot berm at elevation 1827.5 gave a safety factor of 2.2. The steady seepage analysis of the downstream slope, assuming free draining material in the shell, gave a safety factor of 1.94.

3. Appurtenant Structures. The appurtenant structures incorporated into the facility are, for the most part, proven standard SCS designs. Design data are presented within the design report available from the SCS.

2.2 Construction Records.

Construction records including bi-weekly construction status reports, dated photographs and memorandum, and pertinent correspondence are contained in PennDER files. A daily construction narrative prepared by the on-site representative of the SCS is available at the SCS Harrisburg office.

2.3 Operational Records.

No records of the day-to-day operation of this facility are maintained.

2.4 Other Investigations

No formal investigations have been performed on this facility subsequent to its construction.

2.5 Evaluation.

Engineering data were provided by the Pennsylvania Department of Environmental Resources and the U. S. Department of Agriculture, Soil Conservation Service. Sufficient data are available to indicate the structure was formally designed and constructed in accordance with accepted modern engineering practice.

SECTION 3
VISUAL INSPECTION

3.1 Observations.

a. General. The general appearance of this project suggests the dam and its appurtenances are currently in good condition.

b. Embankment. Observations made during the visual inspection reveal the embankment to be in good condition. Some minor erosion was observed along the upstream embankment face directly behind the service spillway riser (see Photograph 3). Unauthorized vehicular traffic across the embankment has left an unprotected rutted strip, void of vegetative cover, along the crest and across the emergency spillway channel (see Photograph 1). Otherwise, no evidence of sloughing, seepage, animal burrows, excess settlements or signs of maintenance neglect were observed.

c. Appurtenant Structures.

1. Service Spillway. The drop inlet, reinforced concrete riser appears to be in excellent condition. No cracks or signs of weathering were observed on either the interior or exterior concrete surfaces of the structure (see Photograph 3). The cover over the manhole that provides access to the interior of the structure from atop the riser was found missing on the day of the inspection.

2. Pond Drain. The pond drain was observed discharging during the inspection. The gate valve controlling flow through the pond drain is apparently stuck in a partially open position and cannot be closed as the valve control located atop the service spillway riser has been recently vandalized and rendered inoperable (see Photograph 4).

d. Reservoir Area. The general area surrounding the reservoir is characterized by gentle to moderate slopes that are partially wooded. PA-657 Dam is designed to be a multi-purpose recreational and flood control facility and is intended to eventually include various picnic and boating facilities along the shoreline.

e. Downstream Channel. The channel downstream of PA-657 Dam is characterized as a broad valley with steep wooded slopes to the right and gentle grassy slopes to the left. Jacobs Creek, in this area, is a small winding stream. At a distance approximately 1/2 mile downstream of the embankment, Jacobs Creek passes through a culvert beneath PA

Route 31. Two commercial establishments are located in this area sufficiently close to the streambed to possibly be affected by an embankment breach. The number of persons which could be potentially involved is dependent on the day and time of failure; however, more than a few can be reasonably assumed. Thus, the hazard classification of the facility is considered "high".

3.2 Evaluation.

The overall condition of the facility is considered good. Immediate repairs to the gate valve control are needed along with a replacement of the missing manhole cover. Consideration should be given to redesigning the present gate valve control to make it more vandalproof and to locking the manhole cover in place. Positive measures should be taken to curtail unauthorized vehicular travel across the crest and through the emergency spillway. All bare areas should be repaired and reseeded.

SECTION 4
OPERATIONAL PROCEDURES

4.1 Normal Operational Procedures.

PA-657 Dam, in its flood control role, is essentially a self-regulating facility. Excess inflow passes through the service spillway and is discharged into the stream below. Inflows in excess of the capacity of the service spillway are stored and/or discharged through the emergency spillway.

According to the PennDER permit for the facility, the owner, via accurate measuring devices, is to maintain a continuous flow in Jacobs Creek immediately below the dam of not less than 0.39 cubic feet per second (252,000 gallons per day). When inflow to the reservoir is less than 252,000 gallons per day, outflow to Jacobs Creek can be reduced to equal reservoir inflow.

Under normal pool conditions a 6-inch diameter outflow line provides cold water discharge (see Figure 10). At the time of inspection, the slide gate on the pond drain was in an open position and the downstream discharge was estimated at 3 to 4 cubic feet per second.

No formal operating manual is available.

4.2 Maintenance of Dam.

The dam as designed requires only limited maintenance which is performed by Westmoreland County personnel in accordance with an agreement with the U.S.D.A., Soil Conservation Service; however, no formal maintenance program has been established. The agreement contains provisions requiring the annual inspection and maintenance of the entire facility and surrounding reservoir area. The owner is required to prepare a report after each inspection and to furnish a copy to the SCS. In addition, a record of all maintenance work performed is required to be readily available for review by the SCS or other authorized agency.

Review of SCS files indicate that yearly inspections have been performed by the SCS and/or owner's personnel during which the condition of the facility was found to be satisfactory.

4.3 Maintenance of Operating Facilities.

Maintenance of the operating facilities is carried out by Westmoreland County personnel on an informal basis and in accordance with the provisions of the agreement discussed in Section 4.2. It is reported that the gate valve is opened several times a year to insure its operability; however, on the day of the inspection, it was found to be inoperable, having recently been vandalized.

4.4 Warning Systems.

There are no formal warning systems in effect.

4.5 Evaluation.

The facility is designed to be self-regulating and requires minimal maintenance. There are no established formal operation and/or maintenance procedures; however, provisions for such procedures are contained within the standard agreement between the SCS and the owner. Nevertheless, formal manuals are recommended to ensure the continued proper care of the facility. A formal warning system should be incorporated into the manuals providing detailed procedures to protect downstream residents and provisions for around-the-clock surveillance during periods of unusually heavy precipitation.

SECTION 5
HYDROLOGIC/HYDRAULIC EVALUATION

5.1 Design Data.

A complete hydrologic/hydraulic analysis as prepared by the U.S.D.A., Soil Conservation Service, is available from SCS files. The report includes design criteria and procedures, stage curves, hydrograph data, and complete routing analysis.

According to this report, the crest of the service spillway is set at elevation 1827.5, which is the elevation required to store 100 years of wet sediment (33 acre-feet) plus recreation storage (60 acre-feet). PennDER's "C" Curve criteria (explained in PennDER Publication No. 41, "Construction or Repair of Dams" 1975) establishes that the dam should have spillway facilities capable of discharging a flow of 3120 cfs.

The dam was designed in accordance with the principles outlined in the National Engineering Handbook of the U. S. Department of Agriculture, Soil Conservation Service. The following is a synopsis of the hydrologic principles developed for this project.

a. The crest of the riser was set at elevation 1827.5 to provide for a 25-acre recreation pool and sediment storage.

b. The crest of the emergency spillway, 1834.9 (field measured to be 1835), was established by routing the runoff from the 100-year frequency, one-day and ten-day storm rainfalls. This resulted in a storage capacity for flood-water retardation of 3.65 acre-feet equivalent to 2.60 inches of runoff.

c. The design high water elevation, 1838.2, was established by routing the runoff from a rainfall of 10.0 inches. This runoff was 7.27 inches with a maximum discharge of 1565 cubic feet per second.

d. The top of dam elevation, 1844.1 (field measured to be 1844.4), was established by routing the runoff from a rainfall of 26.0 inches. Maximum discharge realized in this routing was 8,650 cubic feet per second.

5.2 Experience Data.

No data pertaining to emergency spillway performance are available as it is reported that the emergency spillway has never discharged. The general appearance of the facility indicates adequate past performance of the service spillway.

5.3 Visual Observations.

On the date of the inspection, no conditions were observed that would indicate either the service or emergency spillways could not operate satisfactorily during a flood event. It is noted that the pond drain valve control has been recently rendered inoperable by vandals and left in a partially open position.

5.4 Method of Analysis.

The facility has been analyzed in accordance with the procedures and guidelines established by the U. S. Army, Corps of Engineers, Baltimore District, for Phase I hydrologic and hydraulic evaluations. The analysis has been performed utilizing a modified version of the HEC-1 program developed by the U. S. Army, Corps of Engineers, Hydrologic Engineering Center, Davis, California. Analytical capabilities of the program are briefly outlined in the preface contained in Appendix C.

5.5 Summary of Analysis.

a. Spillway Design Flood (SDF). In accordance with procedures and guidelines contained in the National Guidelines for Safety Inspection of Dams, for Phase I investigations, the SDF for this facility is the PMF (Probable Maximum Flood). That is, based on the relative size (intermediate) and hazard potential (high) of PA-657 Dam, the facility is required to have sufficient spillway and storage capabilities to safely discharge the PMF without overtopping the embankment.

b. Results of Analysis. PA-657 Dam was evaluated under near normal operating conditions. That is, the PA-657 Dam reservoir was initially at its normal or recreation pool elevation of 1827.5 feet (MSL) prior to the inflow of the PMF, with the service spillway assumed to be non-functional for the purpose of analysis. Design information concerning the reservoir's elevation-storage relationship was available and used in the evaluation. Design information was also

available regarding the elevation-discharge relationship of the emergency spillway, but this data was felt to be too conservative for analysis and was not used. The emergency spillway is a vegetated chute channel with a flat, vegetated critical control crest. All pertinent engineering calculations relative to the evaluation of this facility are provided in Appendix C.

Overtopping analysis (using the Modified HEC-1 Computer Program) showed that the discharge/storage capacity of PA-657 Dam can safely accommodate the PMF. That is, the peak PMF inflow of about 5580 cfs (Appendix C, Summary Input/Output Sheets, Sheet B) can be safely discharged and/or stored without overtopping the earth embankment. The peak PMF outflow of about 4760 cfs raises the reservoir water level to approximately elevation 1840.8 feet (Summary Input/Output Sheets, Sheet C). This reservoir level corresponds to about 3.6 feet below the field measured low top of the dam elevation of 1844.4 feet.

5.6 Spillway Adequacy.

Since the emergency spillway of PA-657 Dam is capable of discharging the inflow resulting from a storm of PMF magnitude, the spillway is deemed adequate.

SECTION 6
EVALUATION OF STRUCTURAL INTEGRITY

6.1 Visual Observations.

a. Embankment. Based on visual observations, the embankment appears to be in good structural condition. No evidence of seepage or structural deficiencies were detected during the inspection. Some minor erosion was observed along the upstream embankment face directly behind the service spillway riser. Conversations with the local SCS representative, who accompanied the field team during the inspection, revealed that no riprap was placed along the upstream slope as the material comprising the outer shell (Zone III) was considered sufficiently coarse and did not warrant further protection. It is noted that the Zone III material was covered with topsoil (Zone IV) and the erosion, as observed, may be confined to the Zone IV layer (see Figure 4). Nevertheless, the condition should be assessed and corrected if necessary.

b. Appurtenant Structures. The appurtenant structures of this facility appear to be well designed. All were found in excellent condition during the inspection except for the pond drain operator located atop the service spillway riser. The exposed portion of the mechanism was apparently the recent object of vandalism and was found to be inoperable by the field team.

6.2 Design and Construction Techniques.

Available design data and information obtained from SCS and PennDER files indicate that, for the most part, the facility has been adequately designed in conformance with modern accepted engineering practice. Many of its features have been repeatedly incorporated into similar SCS designs and proven their reliability.

Review of construction progress reports contained in PennDER files indicate that although the duration of construction was lengthy, the work was performed in accordance with the plans and specifications. SCS representatives monitored the work on a full-time basis.

6.3 Past Performance.

According to SCS personnel, the facility has operated virtually problem-free and has functioned as designed.

6.4 Seismic Stability.

The dam is located within Seismic Zone No. 1 and it is thought that the static stability of the structure is sufficient to withstand minor earthquake induced dynamic forces. However, no calculations, and/or investigations, were performed to confirm this belief.

SECTION 7
ASSESSMENT AND RECOMMENDATIONS FOR REMEDIAL MEASURES

7.1 Dam Assessment.

a. Safety. The visual inspection, operational history, and available engineering data suggest that the facility is adequately maintained and in good condition.

Hydraulic and hydrologic calculations indicate that the spillway is capable of discharging the peak flow resulting from a storm of PMF intensity and, therefore, the spillway is considered adequate.

b. Adequacy of Information. The available data are considered sufficient to make an accurate assessment of the facility.

c. Urgency. It is suggested that the recommendations listed below be implemented as soon as possible.

d. Necessity for Additional Investigations. No additional investigations are deemed necessary at this time.

7.2 Recommendations/Remedial Measures.

It is recommended that the owner:

a. Repair the damaged pond drain gate control and replace the missing manhole cover atop the service spillway riser. Consideration should be given to redesigning the gate control mechanism to protect it from future vandalism.

b. Consult with the U.S.D.A., Soil Conservation Service, to assess the erosion on the upstream slope in the area of the service spillway riser and implement any remedial measures deemed necessary.

c. Curtail the unauthorized vehicular travel across the embankment and repair and reseed any damaged (bare) areas. If control of unauthorized travel is not practical, some provision should be made to protect the embankment from rutting and erosion by placing a layer of gravel or stone across the crest.

d. Develop a formal operation and maintenance manual to ensure the continued proper care of the facility. In addition, a formal warning system should be implemented which provides detailed procedures to protect the lives and property of downstream residents and provisions for around-the-clock surveillance during periods of unusually heavy precipitation.

APPENDIX A
CHECK LIST - ENGINEERING DATA

CHECK LIST
ENGINEERING DATA
PHASE I

NAME OF DAM: PA-657 Dam (Acme Dam)
 NDID#: PA-828 PENNDE# : 65-133

ITEM	REMARKS
PERSONS INTERVIEWED AND TITLE	NDID# PA - 828 Bill Bowers (U.S.D.A., Soil Conservation Service, Washington, Pennsylvania office).
REGIONAL VICINITY MAP	See Appendix G (U.S.G.S. 7.5 minute topographic quadrangle Donegal, Pennsylvania).
CONSTRUCTION HISTORY	Mr. Bowers represented the SCS during construction of this facility. Conversations with him indicated that four general contractors were used before the structure was finally completed. However, he also stated that strict specification compliance was achieved.
AVAILABLE DRAWINGS	Complete drawing sets by the SCS are available from both the PennDER and SCS offices in Harrisburg and Washington, Pennsylvania.
TYPICAL DAM SECTIONS	See Figures 4, 6, and 7, Appendix F.
OUTLETS: PLAN DETAILS DISCHARGE RATINGS	See Figure 3, Appendix F. See Figure 7, Appendix F. None available.

ENGINEERING DATA (CONTINUED)

ITEM	REMARKS	NDI# PA - 828
<p>SPELLWAY: PLAN SECTION DETAILS</p>	<p>See Figure 3, Appendix F. See Figures 5 and 7, Appendix F. See Figures 8, 9 and 10, Appendix F.</p>	
<p>OPERATING EQUIPMENT PLANS AND DETAILS</p>	<p>See Figures 9 and 10, Appendix F.</p>	
<p>DESIGN REPORTS</p>	<p>Complete design folder as prepared by the U.S.D.A., Soil Conservation Service is available from SCS offices in Harrisburg and Washington, PA.</p>	
<p>GEOLOGY REPORTS</p>	<p>Contained in design folder (see above)</p>	
<p>DESIGN COMPUTATIONS: HYDROLOGY AND HYDRAULICS STABILITY ANALYSES SEEPAGE ANALYSES</p>	<p>Contained in design folder (see above)</p>	
<p>MATERIAL INVESTIGATIONS: BORING RECORDS LABORATORY TESTING FIELD TESTING</p>	<p>Contained in design folder (see above) Also, see Figures 2 and 5, Appendix F. Also, see drawings 27-30 (not included in Appendix F).</p>	

ENGINEERING DATA (CONTINUED)

ITEM	REMARKS
BORROW SOURCES	<p>See Figure 2, Appendix F. Note: Drawing 1 of 30 "Cover Sheet" (not included in Appendix F) indicates total volume of fill equal to approximately 26,000 cubic yards.</p>
POST CONSTRUCTION DAM SURVEYS	None.
POST CONSTRUCTION ENGINEERING STUDIES AND REPORTS	Yearly inspection reports prepared by the owner (Westmoreland County Commissioners) are available from PennDER.
HIGH POOL RECORDS	No formal records. Mr. Bowers estimated highest pool to date at about 2 or 3 feet above normal pool.
MONITORING SYSTEMS	None.
MODIFICATIONS	None.

NDI# PA - 828

ENGINEERING DATA (CONTINUED)

ITEM	REMARKS	NDI#	PA -828
PRIOR ACCIDENTS OR FAILURES	Recent vandalism evident by the present condition of the pond drain gate control.		
MAINTENANCE: RECORDS MANUAL	None		
OPERATION: RECORDS MANUAL	None		
OPERATIONAL PROCEDURES	No formal procedures. See "Operation and Maintenance Agreement" available from owner, SCS, and PennDER.		
WARNING SYSTEM AND/OR COMMUNICATION FACILITIES	No formal warning systems are in effect.		
MISCELLANEOUS			

CHECK LIST
HYDROLOGIC AND HYDRAULIC
ENGINEERING DATA

NDI ID # PA-828
PENN DER ID # 65-133
PAGE 5 OF 5

SIZE OF DRAINAGE AREA: 2.6 square miles

ELEVATION TOP NORMAL POOL: 1827.5 STORAGE CAPACITY: 93 acre-feet

ELEVATION TOP FLOOD CONTROL POOL: 1835.0 STORAGE CAPACITY: 460 acre-feet

ELEVATION MAXIMUM DESIGN POOL: 1838.2 STORAGE CAPACITY: 850 acre-feet

ELEVATION TOP DAM: 1844.4 STORAGE CAPACITY: 1540 acre-feet

SPILLWAY DATA

CREST ELEVATION: (service) 1827.5; (emergency) 1835.0

TYPE: (service) single-stage drop inlet; (emergency) vegetated
earth channel

CREST LENGTH: (emergency) 100 feet

CREST LENGTH: (service) 13.3 feet

SPILOVER LOCATION: (service) embankment center; (emergency) left
abutment

NUMBER AND TYPE OF GATES: None

Pond Drain

TYPE: 18-inch diameter reinforced concrete pipe

LOCATION: intake at upstream toe, outlet at base of service
spillway riser.

ENTRANCE INVERTS: 1815.6

EXIT INVERTS: 1815.6

EMERGENCY DRAWDOWN FACILITIES: 18-inch diameter slide gate mounted
on inside face of service spillway riser.

HYDROMETEOROLOGICAL GAGES

TYPE: None

LOCATION: --

RECORDS: --

MAXIMUM NON-DAMAGING DISCHARGE: Not known

APPENDIX B
CHECK LIST - VISUAL INSPECTION

CHECK LIST
VISUAL INSPECTION
PHASE 1

NAME OF DAM PA-657 Dam (Acme Dam) STATE Pennsylvania COUNTY Westmoreland
NDI# PA - 828 PENNDR# 65-133
TYPE OF DAM Zoned earth SIZE Intermediate HAZARD CATEGORY High
DATE(S) INSPECTION 4 May 1979 WEATHER overcast with drizzle TEMPERATURE 45° @ 10:00 a.m.
POOL ELEVATION AT TIME OF INSPECTION 1827.5 M.S.L.
TAILWATER AT TIME OF INSPECTION N/A M.S.L.

INSPECTION PERSONNEL

B. M. Mihalcin

W. J. Veon

D. L. Bonk

OWNER REPRESENTATIVES

W. Bowers (U.S.D.A. Soil

Conservation Service -

Washington, PA office)

OTHERS

L. Busack (PennDR)

RECORDED BY D. L. Bonk

EMBANKMENT

ITEM	OBSERVATIONS AND/OR REMARKS	NDI# PA - 828
SURFACE CRACKS	None observed.	
UNUSUAL MOVEMENT OR CRACKING AT OR BEYOND THE TOE	None observed.	
SLOUGHING OR EROSION OF EMBANKMENT AND ABUTMENT SLOPES	Minor erosion of upstream face at about normal pool level directly behind service spillway riser. Unauthorized vehicular travel has resulted in a bare rutted roadway across the entire crest and through the emergency spillway.	
VERTICAL AND HORIZONTAL ALIGNMENT OF THE CREST	Vertical - Good. Horizontal - Good.	
RIPRAP FAILURES	No riprap.	
JUNCTION OF EMBANKMENT AND ABUTMENT, SPILLWAY AND DAM	Good.	

EMBANKMENT

ITEM	OBSERVATIONS AND/OR REMARKS	NDI# PA - 828
DAMP AREAS IRREGULAR VEGETATION (LUSH OR DEAD PLANTS)	None observed along the embankment or the immediate downstream toe.	
ANY NOTICEABLE SEEPAGE	None observed.	
STAFF GAGE AND RECORDER	None.	
DRAINS	12-inch diameter corrugated metal toe drains located in wingwalls of impact basin. Left drain dry; right drain discharging at about 1 gpm. Rock drain located approximately 10 feet below impact basin serves to drain right abutment hillside.	

OUTLET WORKS

ITEM	OBSERVATIONS AND/OR REMARKS	NDIT# PA - 828
INTAKE STRUCTURE	Submerged, not observed.	
OUTLET CONDUIT (CRACKING AND SPALL- ING OF CONCRETE SURFACES)	18-inch diameter reinforced concrete pond drain (submerged, not observed). 30-inch diameter reinforced concrete outlet conduit discharges at downstream toe. No signs of deterioration were observed on exposed surfaces.	
OUTLET STRUCTURE	Standard SCS impact basin design. Good condition, no signs of cracking or spalling of concrete surfaces.	
OUTLET CHANNEL	Trapezoidal-shaped channel riprap lined for 20 feet beyond impact basin.	
GATE(S) AND OPERA- TIONAL EQUIPMENT	18-inch diameter slide gate mounted on the inside face of the service spillway riser and manually operated from atop the riser. Gate control mechanism has been subjected to recent vandalism and presently is inoperable. The gate was observed to be partially open during the inspection allowing the pond drain to discharge at an estimated rate of 3-4 cfs.	

EMERGENCY SPILLWAY

PAGE 5 OF 8

ITEM	OBSERVATIONS AND/OR REMARKS	NDI# PA - 828
TYPE AND CONDITION	Unlined vegetated earth channel with a trapezoidal cross-section cut into the left abutment.	
APPROACH CHANNEL	Curved section of the above described channel.	
SPILLWAY CHANNEL AND SIDEWALLS	Good condition.	
STILLING BASIN PLUNGE POOL	Not applicable.	
DISCHARGE CHANNEL	Discharge is diverted over the left abutment hillside and into the stream located at the base of the valley downstream.	
BRIDGE AND PIERS	None.	
EMERGENCY GATES	None.	

SERVICE SPILLWAY

PAGE 0 OF 8

ITEM	OBSERVATIONS AND/OR REMARKS
TYPE AND CONDITION	Standard SCS single-stage, drop inlet riser. Good condition. No visible signs of concrete deterioration observed.
APPROACH CHANNEL	Not applicable.
OUTLET STRUCTURE	Standard SCS impact basin design. Good condition. No visible signs of concrete deterioration observed.
DISCHARGE CHANNEL	See Sheet 4 of 8 "Outlet Channel".

INSTRUMENTATION
OBSERVATIONS AND/OR REMARKS

NDJH PA - 828

ITEM	OBSERVATIONS AND/OR REMARKS
MONUMENTATION SURVEYS	None observed.
OBSERVATION WELLS	None observed.
WEIRS	None observed.
PIEZOMETERS	None observed.
OTHERS	

RESERVOIR AREA AND DOWNSTREAM CHANNEL

NDI# PA - 828

OBSERVATIONS AND/OR REMARKS

ITEM	
SLOPES: RESERVOIR	Gentle to moderate and partially wooded. Partial agricultural development in evidence within the watershed.
SEDIMENTATION	None observed.
DOWNSTREAM CHANNEL (OBSTRUCTIONS, DEBRIS, ETC.)	About 1/2 mile and 1-1/2 miles downstream of PA-657 Dam, Jacobs Creek passes beneath PA Route 31 and the Pennsylvania Turnpike, respectively.
SLOPES: CHANNEL VALLEY	The valley downstream of PA-657 Dam is broad and thickly vegetated with small trees and brush. The valley side slopes are steep and wooded to the right and gentle and grassy to the left.
APPROXIMATE NUMBER OF HOMES AND POPULATION	Two commercial establishments are located along the stream about 1/2 mile downstream of the embankment at PA Route 31. They are sufficiently close to the stream to likely be affected by an embankment breach. The number of persons who could be potentially involved is dependent on the day and time of failure; however, more than a few can be reasonably assumed.

APPENDIX C
HYDROLOGY AND HYDRAULICS

PREFACE

The modified HEC-1 program is capable of performing two basic types of hydrologic analyses: (1) the evaluation of the overtopping potential of the dam; and (2) the estimation of the downstream hydrologic-hydraulic consequences resulting from assumed structural failures of the dam. Briefly, the computational procedures typically used in the dam overtopping analysis are as follows:

- a. Development of an inflow hydrograph(s) to the reservoir.
- b. Routing of the inflow hydrograph(s) through the reservoir to determine if the event(s) analyzed would overtop the dam.
- c. Routing of the outflow hydrograph(s) from the reservoir to desired downstream locations. The results provide the peak discharge(s), time(s) of the peak discharge(s), and the maximum stage(s) of each routed hydrograph at the downstream end of each reach.

The evaluation of the hydrologic-hydraulic consequences resulting from an assumed structural failure (breach) of the dam is typically performed as outlined below.

- a. Development of an inflow hydrograph(s) to the reservoir.
- b. Routing of the inflow hydrograph(s) through the reservoir.
- c. Development of a failure hydrograph(s) based on specific breach criteria and normal reservoir outflow.
- d. Routing of the failure hydrograph(s) to desired downstream locations. The results provide estimates of the peak discharge(s), time(s) to peak, and maximum water surface elevation(s) of the failure hydrograph(s) for each location.

SUBJECT DAM SAFETY INSPECTION
PA-257 DAM
 BY WJV DATE 5-16-79 PROJ. NO. 79-117-400
 CHKD. BY DLB DATE 5-24-79 SHEET NO. 1 OF 5



DAM STATISTICS

HEIGHT OF DAM \approx 33 FT (FIELD MEASUREMENTS)
 MAXIMUM POOL STORAGE CAPACITY \approx 1510 AC-FT (SEE SHEET 3)
 @ TOP OF DAM
 NORMAL POOL STORAGE CAPACITY \approx 93 AC-FT (SEE NOTE 1)
 @ TOP OF RECREATION POOL
 DRAINAGE AREA \approx 2.6 SQ MI.
 [PLANIMETRICALLY DERIVED FROM 7.5 MINUTE DUNELONG, PA. MAP]

NOTE 1: NORMAL POOL STORAGE CAPACITY OBTAINED FROM THE "REPORT UPON THE APPLICATION OF THE COMMONWEALTH OF WESTMORELAND COUNTY [TO CONSTRUCT AND MAINTAIN A DAM ACROSS JACOB'S CREEK IN MOULTON BOROUGHS TOWNSHIP, WESTMORELAND COUNTY]" (1974) WHICH IS TO BE FOUND IN FILES; AND ALL OTHER RELEVANT INFORMATION IS AS PRESENTED ON SHEET 3

DAM CLASSIFICATION

DAM SIZE - INTERMEDIATE (SEE NOTE 1)
 (DUE TO STORAGE CAPACITY)
 HAZARD CLASSIFICATION - HIGH
 REGULATORY BODY - PAWE (SEE NOTE 1)

SUBJECT DAM SAFETY INSPECTION

PA-657 DAM

BY WJV DATE 5-21-79 PROJ. NO. 78-617-329

CHKD. BY DLB DATE 5-25-79 SHEET NO. 2 OF 8



Engineers • Geologists • Planners
Environmental Specialists

HYDROGRAPH PARAMETERS

LENGTH OF LONGEST WATERCOURSE \approx 3.0 MI

$L_{CA} \approx$ 1.4 MI (MEASURED ALONG THE LONGEST WATERCOURSE FROM THE DAM CREST TO THE CENTER OF THE BASIN)

NOTE 2: VALUES OF L AND L_{CA} ARE MEASURED FROM THE USGS 7.5 MINUTE DONEGAL, PA QUAD. ALL HYDROGRAPH VARIABLES ARE DEFINED IN REF. 2 TO THE SECTION ENTITLED "SNYDER SYNTHETIC UNIT HYDROGRAPH".

$C_+ \approx$ 1.0
 $C_p \approx$ 0.45

[SUPPLIED BY CCE, ZONE 25
OHIO RIVER BASIN]

$T_p =$ UNIFIED STANDARD LAG \approx $1.0 (L_{CA})^{0.7}$

$\therefore T_p = 1.0 (3.0 \times 1.4)^{0.7} \approx$ 1.54 HRS

RESERVOIR ELEVATION-STORAGE RELATIONSHIP

THE ACTUAL DESIGN RELATIONSHIP FOR THE DAM WAS OBTAINED FROM THE SDC DESIGN FILES AND IS PROVIDED ON SHEET 3. THIS RELATIONSHIP WILL BE USED IN THE ANALYSIS.

DA-657
Jacobs Creek

WDC
Feb 16, 1955

SHEET 3 OF 9

Stage vs Storage

EA - DAM IN PLACE

NOTE - CHANGE TO EB INSIGNIFICANT 2/15/55
(SEE OFFICE COPY OF MAP)

(THIS PLOT WAS OBTAINED FROM THE DESIGN FILES FOR THE DAM THROUGH THE WASHINGTON, PA OFFICE OF THE SCS)

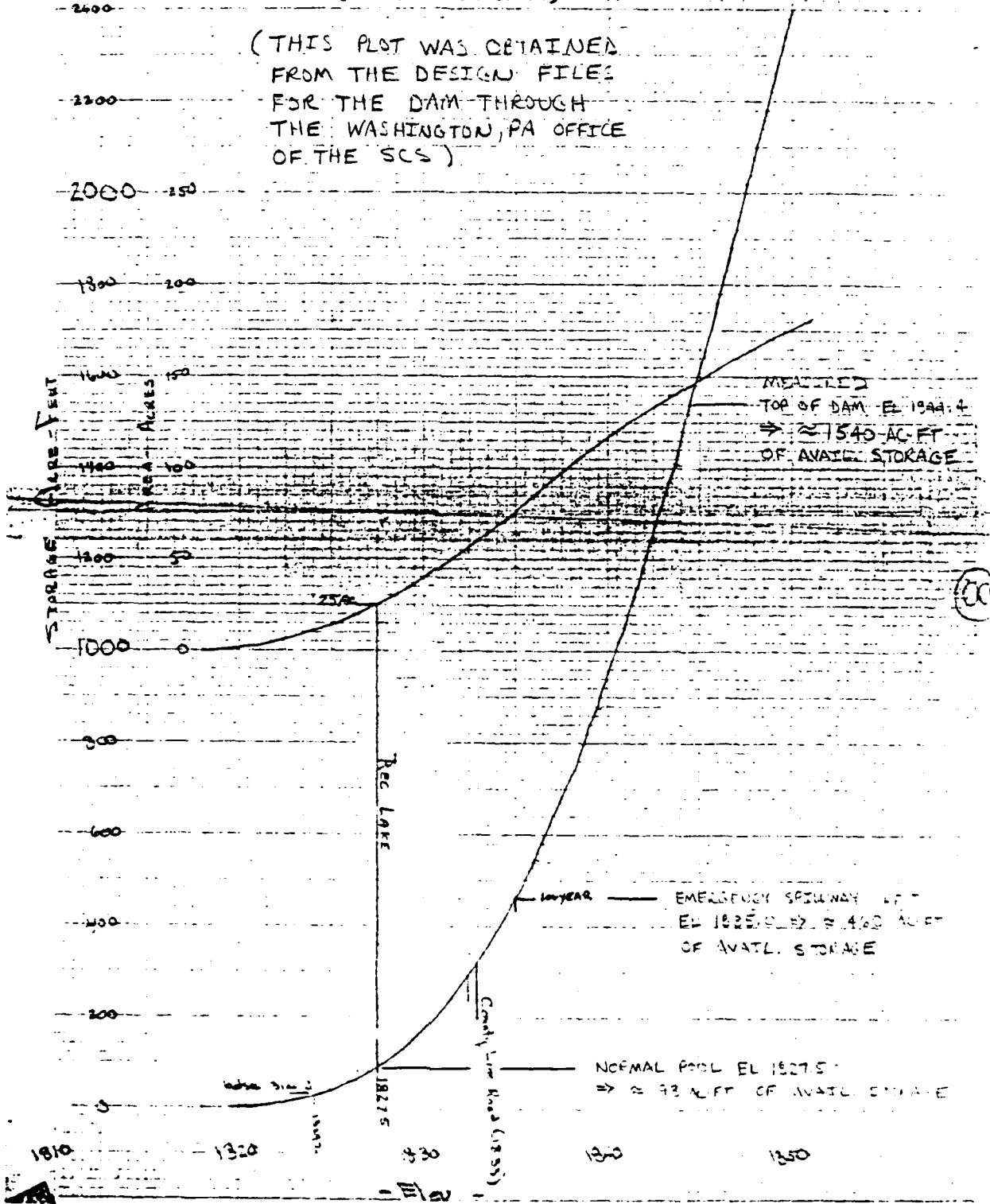

SUBJECT DAM SAFETY INSPECTION

PA-657 DAM

BY WJV DATE 5-21-79 PROJ. NO. 73-17-928

CHKD. BY DLB DATE 5-25-79 SHEET NO. 4 OF 8



Engineers • Geologists • Planners
Environmental Specialists

PMP CALCULATION:

- APPROXIMATE RAINFALL INDEX = 24 IN (REF 3, FIG 1)
(CORRESPONDING TO A DURATION OF 24 HOURS AND AN AREA OF 200 SQ MI IN SOUTHWESTERN PENNSYLVANIA)
- DEPTH-AREA-DURATION ZONE #7 (REF 3, FIG 1)
- DRAINAGE AREA = 2.6 SQ MI \Rightarrow ASSUME THAT DATA CORRESPONDING TO A 10 SQ MI AREA IS REPRESENTATIVE OF THIS BASIN:

DURATION (HR)	PERCENT OF INDEX RAINFALL (%)
6	102
12	120
24	130
48	140

- HOB SPILL FACTOR (ADJUSTMENT FOR BASIN SHAPE AS WELL AS FOR THE LESSEER LIKELIHOOD OF A SEVERE STORM CENTERING OVER A SMALLER BASIN) CONSIDERED AS 1.0 FOR A DAM 2.6 SQ MI (< 10 SQ MI) \Rightarrow 0.8 (REF 1, FIG 1)

THIS PAGE IS BEST QUALITY REPRODUCIBLE
BY THE USE OF MICROFILM

SUBJECT DAM SAFETY INSPECTION
PA-657 DAM
 BY WJV DATE 5-21-79 PROJ. NO. 72-117 020
 CHKD. BY JLR DATE 5-25-79 SHEET NO. 5 OF 8



SPILLWAY CAPACITY (SERVICE)

THE PRINCIPAL SPILLWAY IS A CONVENTIONAL SCS DROP-INLET, VERTICAL RISER STRUCTURE W/ A 30" OUTLET PIPE. ACCORDING TO DESIGN INFORMATION (OBTAINED FROM THE SCS), THE CAPACITY OF THE SERVICE OR PRINCIPAL SPILLWAY IS ONLY ABOUT 120 CFS PRIOR TO OVERTOPPING OF THE EMBANKMENT ⇒ IGNORE THE EFFECTS OF THE SERVICE SPILLWAY.

SPILLWAY CAPACITY (EMERGENCY)

- PROFILE OF EMERGENCY SPILLWAY: (NOT TO SCALE)
 (BASED ON FIELD MEASUREMENT AND DELEVATION; AND FIG.)

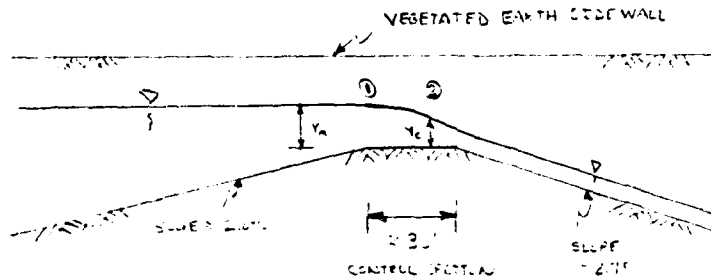

- CROSS-SECTION OF EMERGENCY SPILLWAY: (NOT TO SCALE)
 (BASED ON FIELD MEASUREMENT AND DELEVATION; AND FIG.)

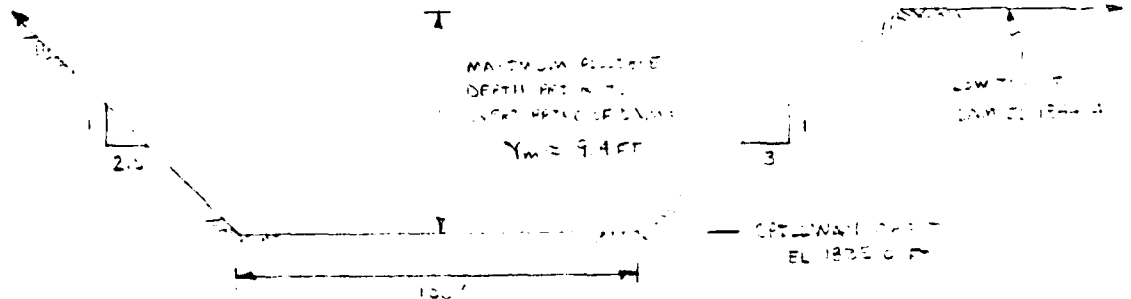

SPILLWAY TRACED LOOKING DOWNSTREAM @ EMBANKMENT SPILLWAY

SUBJECT DAM SAFETY INSPECTION
PA-657 DAM
 BY WJV DATE 5-21-79 PROJ. NO. 73-117-824
 CHKD. BY DLB DATE 5-25-79 SHEET NO. 6 OF 8



- ASSUME THAT THE WATER SURFACE PROFILE PASSES THROUGH CRITICAL DEPTH @ ② (AS SHOWN ON SKETCH ON SHEET 5):
 ENERGY BALANCE BETWEEN ① AND ② \Rightarrow

$$Y_m + \frac{V_1^2}{2g} + Z_1 = Y_c + \frac{V_c^2}{2g} + Z_2 + H_L \quad \text{(REF 7, PG 41)}$$

WHERE V_1 = RESERVOIR APPROACH VELOCITY @ ①
 Z_1 = ELEVATION @ ① IN FT,
 V_c = CRITICAL VELOCITY @ ② IN FT/SEC,
 Z_2 = ELEVATION @ ② IN FT, AND
 H_L = HEAD LOSS BETWEEN ① AND ② IN FT

SINCE $Z_1 - Z_2 \approx 0$ (ESTIM LOCATIONS ON FLAT CONTROL SECTION)

$$\therefore Y_m \approx 9.4 \text{ FT} = Y_c + \frac{V_c^2}{2g}$$

- FOR A TRIANGULAR SHAPED CONTROL SECTION W/ CRITICAL DEPTH $\Rightarrow \frac{V_c^2}{2g} = \frac{A_c}{W_c}$ (REF 7, PG 42)

WHERE A_c = HYDRAULIC DEPTH = FLOW AREA @ CRITICAL DEPTH = $A_c = W_c Y_c$

$$A_c = 100 Y_c + \frac{1}{2} (3 Y_c \times Y_c) + \frac{1}{2} (2.5 Y_c \times Y_c)$$

$$= 100 Y_c + 2.75 Y_c^2$$

$$W_c = 100 + 3 Y_c + 2.5 Y_c = 100 + 5.5 Y_c$$

FROM GEOMETRY ON SHEET 5

$$\therefore 9.4 = Y_c + \frac{A_c}{W_c} = Y_c + \frac{100 Y_c + 2.75 Y_c^2}{2(100 + 5.5 Y_c)}$$

SOLVE FOR $Y_c \Rightarrow$

$$9.4 (200 + 11 Y_c) = Y_c (200 + 11 Y_c) + (100 Y_c + 2.75 Y_c^2)$$

$$0 = 12.75 Y_c^2 - 13.4 Y_c - 1892$$

THIS PROJECT IS EAST QUALITY PRACTICE
 AND I PROMISE TO DO

SUBJECT DAM SAFETY INSPECTION
PA-157 DAM
 BY WJV DATE 5-21-79 PROJ. NO. 78-617-928
 CHKD. BY DLB DATE 5-25-79 SHEET NO. 7 OF 8

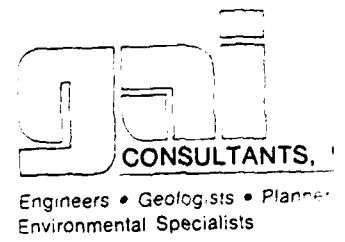

⇒ $Y_c \approx 3.6 \text{ FT}$ (VIA THE QUADRATIC EQUATION)
 $A_c \approx 730 \text{ FT}^2$
 $\frac{V_c^3}{g Y_c} \approx 2.0 \text{ FT}$
 $V_c \approx 13.4 \text{ FPS}$

∴ $Q = A_c V_c \approx (730 \text{ FT}^2)(13.4 \text{ FPS}) \approx 10430 \text{ CFS}$

- CHECK TO SEE IF CRITICAL FLOW ACTUALLY DOES CONTROL
 ⇒ CHANNEL SLOPE DS FROM CONTROL SECTION SHOULD BE A SUPERCRITICAL SLOPE (> CRITICAL SLOPE)

CRITICAL SLOPE CAN BE DEFINED BY MANNING'S EQUATION (REF 13, PG 143):

$$S_c \approx \left(\frac{n V_c}{1.49 R_c^{2/3}} \right)^2$$

WHERE S_c = CRITICAL SLOPE CORRESPONDING TO A FLOW WITH VELOCITY V_c .

n = ROUGHNESS FACTOR ≈ 0.032 BARS ON
 $V_c R_c$ PRODUCT = 75.0 AND VEGETATIVE
 RETARDANCE CLASSIFICATION "C" (REF 13, PG 143)

R_c = HYDRAULIC RADIUS = FLOW AREA / NETTED PERIMETER
 $= 730 \text{ FT}^2 / (100 + \sqrt{3600 + 4(730)(100)}) \approx 5.0 \text{ FT}$

∴ $S_c = \left[\frac{(0.032)(13.4)}{1.49(5.0)^{2/3}} \right]^2 \approx 0.01 \text{ FT/FT}$
 < 0.02 FT/FT
 (A-10)

⇒ CRITICAL FLOW CONTROLS AND ENERGY
 SPILLWAY CAPACITY $\approx 10430 \text{ CFS}$ (OR 10430 CFS
 AND ABOVE BY NOT EXCEEDING

THIS PAGE IS BEST QUALITY REPRODUCTION OF ORIGINAL DRAWING FROM COPY SENT TO YOU

SUBJECT DAM SAFETY INSPECTION

FA-657 DAM

BY WJV DATE 5-21-79 PROJ. NO. 79-017-829

CHKD. BY DLB DATE 5-25-79 SHEET NO. 3 OF 8



Engineers • Geologists • Planners
Environmental Specialists

SPILLWAY RATING CURVE (EMERGENCY)

COMPUTED INTERNALLY BY HEC-1 VIA THE TRAPEZOIDAL RATING CURVE ROUTINE, BASED ON THE SPILLWAY GEOMETRY AS PRESENTED ON SHEET 5. THE TRAPEZOIDAL ROUTINE CALCULATES CRITICAL CONTROL DISCHARGES IN A WAY SIMILAR TO THAT OUTLINED ON SHEETS 6 AND 7 (SEE SUMMARY INPUT/OUTPUT SHEETS)

SUBJECT DAM SAFETY TUSSE TUND
PA-657 DAM
 BY WJV DATE 6-4-79 PROJ. NO. 73-617-220
 CHKD. BY DLB DATE 6-5-79 SHEET NO. A OF C

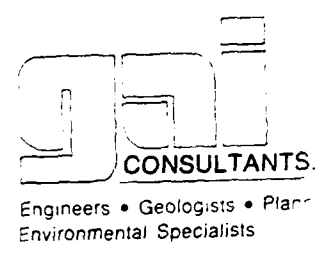

SUMMARY INPUT/OUTPUT SHEETS

DAM SAFETY INSPECTION
 PA-657 (SCS DAM) ***** OVERTOPPING ANALYSIS *****
 10-MINUTE TIME STEP AND 48-HOUR STORM DURATION

NO NHH NHIN IDAY IHR IMIN HEIKC IPRT NSIAN
 288 0 10 0 0 0 0 0 0 0
 JOPEL NWT LRUPT TRACE
 5 0 0 0

JOB SPECIFICATION
 MULTI-PLAN ANALYSES TO BE PERFORMED
 NPLAN= 1 NRTIO= 1 LRTIO= 1

NTIOS= 1.00

SUB-AREA RUNOFF COMPUTATION

INFLOW INTO RESERVOIR

ISTAQ 1 ICOMP 0 IECOM 0 ITAPE 0 JPLT 0 JPRT 0 INAME 1 ISAGE 1 AUTO 0

HYDG 1 IUNG 1 TAHEA 2.60 TRSDA 2.60 TRSPC 0.00 0.00 0.00 0.00
 SNRP 0.00 0.00 0.00 0.00 0.00 0.00 0.00 0.00 0.00 0.00
 R48 R72 R96
 140.00 0.00 0.00

PRECIP DATA
 H12 H24 R48 R72 R96
 120.00 130.00 140.00 0.00 0.00

INITIAL AND CONSTANT NATURAL LOSS RATE
 OBTAINED FROM THE GAITHORE DISTRICT
 COE

LOSS DATA
 STRTL CNSTL ALSHX RTIMP
 1.00 .05 0.00 0.00

UNIT HYDROGRAPH DATA
 TP= 1.54 CP= .40 NTA= 0

BASE FLOW PARAMETERS
 REVISION DATA
 STRFO= -1.50 ORCSN= -.05 NTIOR= 2.00

APPROXIMATE CLARK COEFFICIENTS FROM GIVEN SWYDER CP AND TP ARE TC= 9.67 AND R=17.26 INTERVALS

TRSPC COMPUTED BY THE PROGRAM IS .800

SUBJECT

LAM SAFETY INSPECTION

PA-657 LAM

BY WJV

DATE

3-4-79

PROJ. NO.

73-617-823

CHKD. BY DLB

DATE

6-5-79

SHEET NO.

P OF C



Engineers • Geologists • Planners
Environmental Specialists

UNIT	HYDROGRAPH	97	END-OF-PERIOD	UNDINATES,	LAGS	1.55	HOURS,	CP	.40	VOLUME	1.00
13.	50.	103.	166.	237.	306.	365.	410.	437.	442.		
424.	400.	378.	356.	316.	317.	300.	283.	267.	252.		
238.	224.	212.	200.	188.	178.	168.	158.	149.	141.		
135.	126.	119.	114.	100.	100.	74.	81.	64.	79.		
15.	70.	66.	59.	56.	53.	53.	50.	47.	44.		
42.	39.	37.	35.	33.	31.	29.	28.	26.	25.		
23.	22.	21.	20.	19.	18.	17.	16.	15.	14.		
13.	12.	11.	10.	10.	9.	9.	9.	8.	8.		
7.	7.	6.	6.	6.	5.	5.	5.	5.	4.		
4.	4.	3.	3.	3.	3.	3.	3.	3.	4.		

END-OF-PERIOD FLOW

NO. DA	HR. MM	PERIOD	RAIN	EACS	LUSS	COMP Q
SUN	26.88	24.45	2.42	2.42	2.42	2.42
	(683.)	(621.)	(61.)	(61.)	(6459.84)	

TOTAL VOLUME 227624.

6446.

22.62

574.60

3135.

3867.

PMF

RESERVOIR

NO. DA	HR. MM	PERIOD	RAIN	EACS	LUSS	COMP Q
6-HOUR	4110.	1536.	790.			
24-HOUR	43.	22.				
72-HOUR	21.98	22.62				
PEAK	5583.	158.				
CFS	116.					
CMS	14.70	373.48	574.60	3135.	3867.	
INCHES	2038.	2514.				
MM						
AC-FT						
THOUS CU M						

HYDROGRAPH ROUTING

ROUTE THROUGH RESERVOIR

ISIAQ	ICOMP	IECON	ITAPE	JPLT	JPRT	INAME	ISTAGE	IAUTO
101	1	0	0	0	0	1	0	0
ROUTING DATA								
IRES	AVG	IRES	ISAME	IOPT	IPMP		LSTR	
0.0	0.00	1	1	0	0		0	
NSTPS	NSTDG	LAG	AMSKK	X	TSK	STORA	ISPRAT	
1	0	0	0.000	0.000	0.000	93.	1	
93.	140.	240.	360.	460.	740.	1100.	1540.	
1828.	1829.	1832.	1831.	1835.	1838.	1841.	1844.	
CREL	SPWID	COON	EXPW	ELEVEL	COUL	CAREA	EXPL	
1835.0	100.0	0.0	0.0	0.0	0.0	0.0	0.0	
IABCOA	ISPITW	ISPCTW						
0	0	0						

SUBJECT DAM SAFETY INSPECTION

PA-657 DAM

BY WJV DATE 6-4-79 PROJ. NO. 72-617-523

CHKD. BY JLB DATE 6-5-79 SHEET NO. C OF C

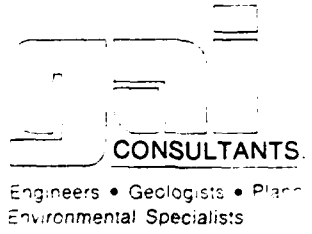

	SS	MGATES	DESHD	APEL	APWID	APLOSS	DPPTH
	2.75	1	9.4	0.0	0.0	0.0	0.0
1818.00	0.	0.	0.	0.	0.	0.	0.
1827.50	93.	0.	0.	0.	0.	0.	0.
1829.30	140.	0.	0.	0.	0.	0.	0.
1831.50	240.	0.	0.	0.	0.	0.	0.
1833.50	360.	0.	0.	0.	0.	0.	0.
1835.00	460.	0.	0.	0.	0.	0.	0.
1838.20	740.	1864.	0.	1864.	1864.	1864.	0.
1841.20	1100.	5242.	0.	5242.	5242.	5242.	0.
1844.40	1540.	10182.	0.	10182.	10182.	10182.	0.

DAM DATA
 TOPEL 1844.4
 CUOD 0.0
 EXPD 0.0
 DAMWID 0.

PEAK OUTFLOW IS 4758. AT TIME 42.67 HOURS

PEAK OUTFLOW
 WIDE-SCAPE

	6-HOUR	24-HOUR	72-HOUR	TOTAL VOLUME
PEAK	4758.	1272.	636.	183193.
CFS	3856.	36.	18.	5197.
CMH	109.	18.21	18.21	16.21
INCHES	13.80	462.44	462.44	462.44
MM	350.46	2523.	2523.	2523.
AC-FT	1912.	3112.	3112.	3112.
THOUS CU H	2359.			

PMF

SUMMARY OF DAM SAFETY ANALYSIS

	INITIAL VALUE	SPILLWAY CREST	TOP OF DAM
ELEVATION	1827.50	1835.00	1844.40
STORAGE	93.	460.	1540.
OUTFLOW	0.	0.	10182.

RATIO OF PMF	MAXIMUM DEPTH OVER DAM	MAXIMUM STORAGE AC-FT	MAXIMUM OUTFLOW CFS	DURATION OVER TOP HOURS	TIME OF FAILURE HOURS
1.00	0.00	1098.	4758.	0.00	42.67
					0.00

LIST OF REFERENCES

1. "Recommended Guidelines for Safety Inspection of Dams," prepared by Department of the Army Office of the Chief of Engineers, Washington, D. C. (Appendix D).
2. "Unit Hydrograph Concepts and Calculations," by Corps of Engineers, Baltimore District (L-519).
3. "Seasonal Variation of Probable Maximum Precipitation East of the 105th Meridian for Areas from 10 to 1,000 Square Miles and Duration of 6, 12, 24, and 48 Hours," Hydrometeorological Report No. 33, prepared by J. T. Riedel, J. F. Appleby and R. W. Schloemer Hydrologic Service Division Hydrometeorological Section, U. S. Department of the Army, Corps of Engineers, Washington, D. C., April 1956.
4. Design of Small Dams, U. S. Department of the Interior, Bureau of Reclamation, Washington, D. C., 1973.
5. Handbook of Hydraulic, H. W. King and E. F. Brater, McGraw-Hill, Inc., New York, 1963.
6. Standard Handbook for Civil Engineers, F. S. Merritt McGraw-Hill, Inc., New York, 1968.
7. Open-Channel Hydraulics, V. T. Chow, McGraw-Hill, Inc., New York, 1959.
8. Weir Experiments, Coefficients, and Formulas, R. E. Horton, Water Supply and Irrigation Paper No. 200, Department of the Interior, United States Geological Survey, Washington, D. C., 1907.
9. "Probable Maximum Precipitation Susquehanna River Drainage Above Harrisburg, Pennsylvania," Hydrometeorological Report 40, prepared by H. V. Goodyear and J. T. Riedel, Hydrometeorological Branch Office of Hydrology, U. S. Weather Bureau, U. S. Department of Commerce, Washington, D. C., May 1965.
10. Flood Hydrograph Package (HEC-1) Dam Safety Version, Hydrologic Engineering Center, U. S. Army Corps of Engineers, Davis, California, July 1978.
11. "Simulation of Flow Through Broad Crest Navigation Dams with Radial Gates," R. W. Schmitt, U. S. Army Corps of Engineers, Pittsburgh District.

12. "Hydraulics of Bridge Waterways," BPR, 1970, Discharge Coefficient Based on Criteria for Embankment Shaped Weirs, Figure 24, page 46.
13. Applied Hydraulics in Engineering, Morris, Henry M. and Wiggert, James N., Virginia Polytechnic Institute and State University, 2nd Edition, The Ronald Press Company, New York, 1972.
14. Standard Mathematical Tables, 21st Edition, The Chemical Rubber Company, 1973, page 15.
15. Engineering Field Manual, U. S. Department of Agriculture, Soil Conservation Service, 2nd Edition, Washington, D. C. 1969.

APPENDIX D
PHOTOGRAPHS

PHOTOGRAPH 1

View of the embankment as seen from the left abutment atop the left channel wall of the emergency spillway. Note the unprotected vehicle path that runs across the emergency spillway and embankment crest.

PHOTOGRAPH 2

View of the embankment as seen from the right abutment hillside.

PHOTOGRAPH 3

View of the service spillway riser and upstream face of embankment. Note the minor erosion of the unprotected slope behind the riser.

PHOTOGRAPH 4

Close-up view of the pond drain gate control situated atop the service spillway riser. The mechanism was the apparent object of recent vandalism which has rendered it inoperable.



1



2



4

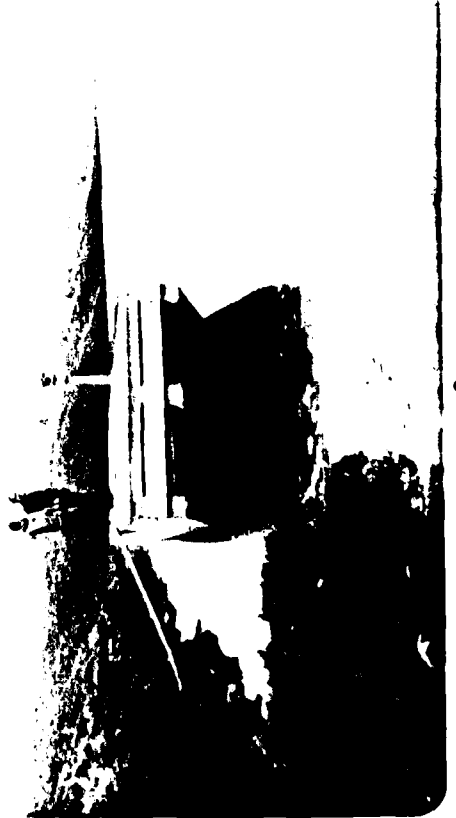

3

PHOTOGRAPH 5

View through the manhole opening of the interior of the service spillway riser. The manhole cover was missing on the day of the inspection.

PHOTOGRAPH 6

View of the impact basin energy dissipator located at the downstream embankment toe at the outlet end of the service spillway discharge conduit.

PHOTOGRAPH 7

View looking downstream from the crest of the embankment.

PHOTOGRAPH 8

View of the embankment as seen from several hundred feet downstream.



6



8



5



7

APPENDIX E

GEOLOGY

Geology¹

PA-657 Dam is located in the Allegheny Mountain Section of the Appalachian Plateaus Physiographic Province of western Pennsylvania. In this area, the Allegheny Mountain Section is characterized by gently folded sedimentary rock strata of Pennsylvanian age. Major structural axes strike from southwest to northeast with flanking strata dipping northwest and southeast.

The dam site is located about 0.5 mile east of the crest of the Chestnut Ridge Anticline. The rock strata at the dam site dip east-southeast at approximately 6 degrees. The site is underlain by sandstone, siltstone, clays, shales, and coals of the Allegheny Group of Pennsylvanian age. Drilling and test pit data² indicate a residual sandy silt and silty sand blanket on both abutments, being 3 to 9 feet thick on the left abutment and 1 to 2 feet thick on the right abutment.

Bedrock was encountered in all of the foundation drill-holes and consists of interbedded sandstone, siltstone, and clay. Sandstone is the predominant rock type present and weathering depths range from about 10 feet on the left abutment to about 25 feet on the right abutment. About 5 percent of the original left abutment slope was covered with boulders in excess of one cubic yard in size.

The Jacobs Creek floodplain is covered with interbedded alluvial sediments classified as silts, clays, and sandy

silts with occasional large boulders. Permeability tests in the alluvial sediments generally showed permeability rates to be less than 1.0 foot per day.

¹Shaffner, Marchant N., "Geology and Mineral Resources of the Donegal Quadrangle, Pennsylvania," Harrisburg: Topographic and Geologic Survey, Atlas No. 48, 1963.

²Engineering data presented in this section have been taken from the "Jacobs Creek Watershed Project (Design Manual)," prepared by the U. S. Department of Agriculture, Soil Conservation Service, 1971.

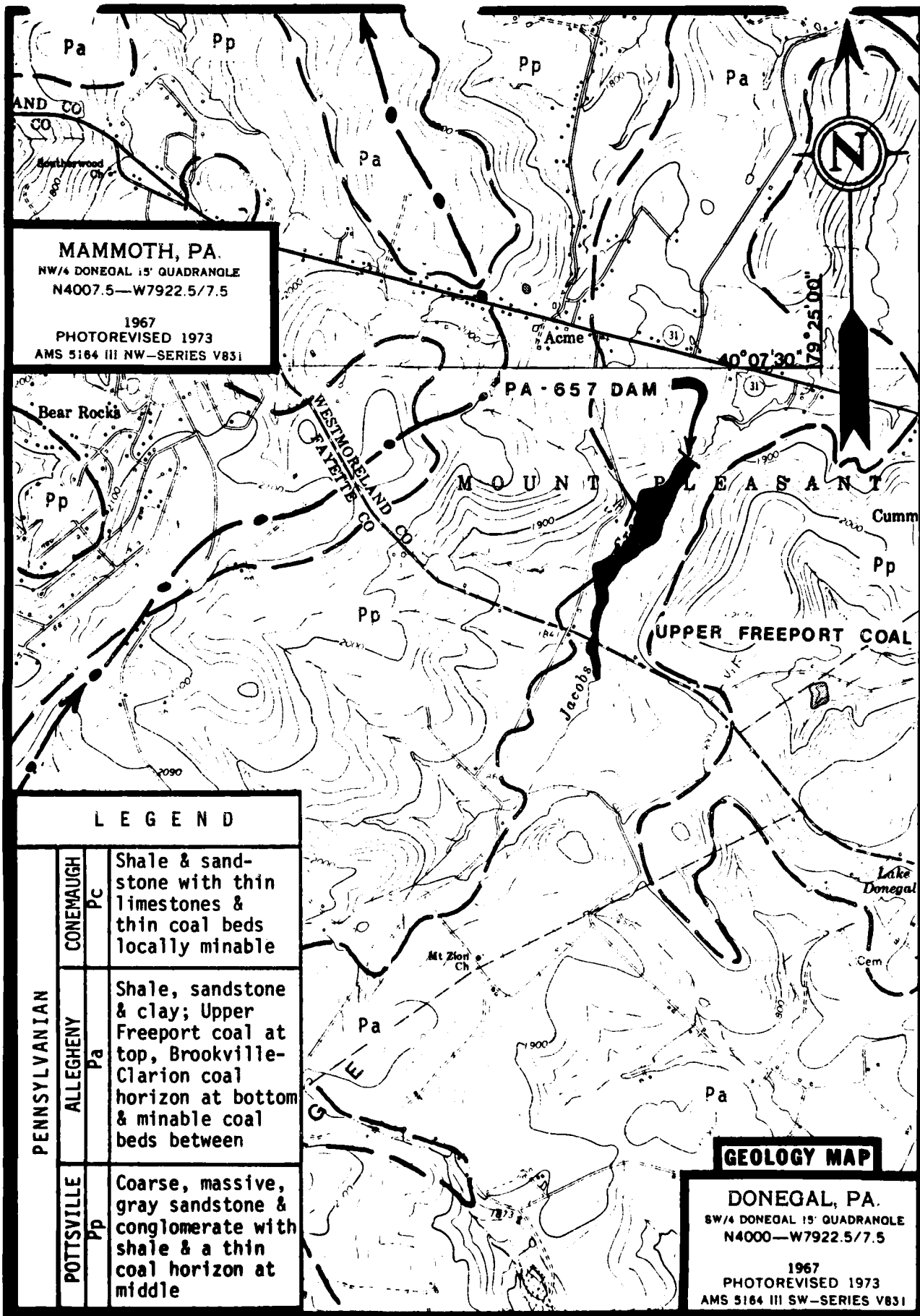

MAMMOTH, PA.
 NW 1/4 DONEGAL 15' QUADRANGLE
 N4007.5—W7922.5/7.5

1967
 PHOTOREVISED 1973
 AMS 5164 III NW—SERIES V831

PENNSYLVANIAN		LEGEND
	CONEMAUGH Pc	Shale & sandstone with thin limestones & thin coal beds locally minable
	ALLEGHENY Pa	Shale, sandstone & clay; Upper Freeport coal at top, Brookville-Clarion coal horizon at bottom & minable coal beds between
	POTTSVILLE Pp	Coarse, massive, gray sandstone & conglomerate with shale & a thin coal horizon at middle

GEOLOGY MAP

DONEGAL, PA.
 SW 1/4 DONEGAL 15' QUADRANGLE
 N4000—W7922.5/7.5

1967
 PHOTOREVISED 1973
 AMS 5164 III SW—SERIES V831

APPENDIX F

FIGURES

LIST OF FIGURES

<u>Figure</u>	<u>Description/Title</u>
1	General Plan (field inspection notes)
2	Plan of Storage Area
3	Plan of Structural Works
4	Field Placement
5	Profile Along Centerline of Dam
6	Drainage
7	Service Spillway
8	Riser Details
9	Riser Accessories
10	Cold Water Release

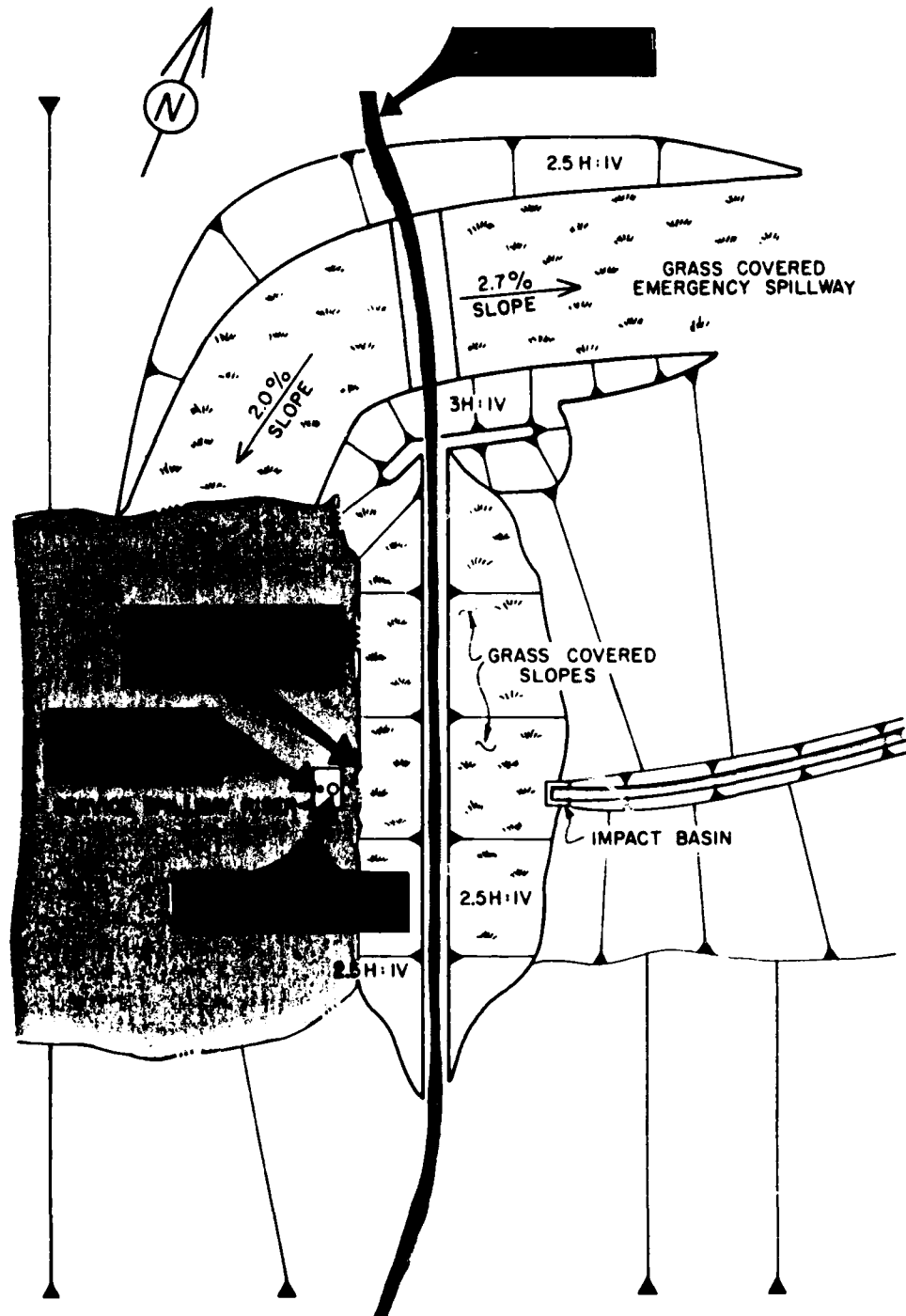

FIGURE 1 - PA - 657 DAM
 GENERAL PLAN
 FIELD INSPECTION NOTES

Match Line
650
640
650

Match Line
650
640
650

Permanent Pool El. 18275

CLEARING & GRUBBING AREA

SPOIL AREA

Diversion

Dirt Rd

6" (approx)

3' max

SP

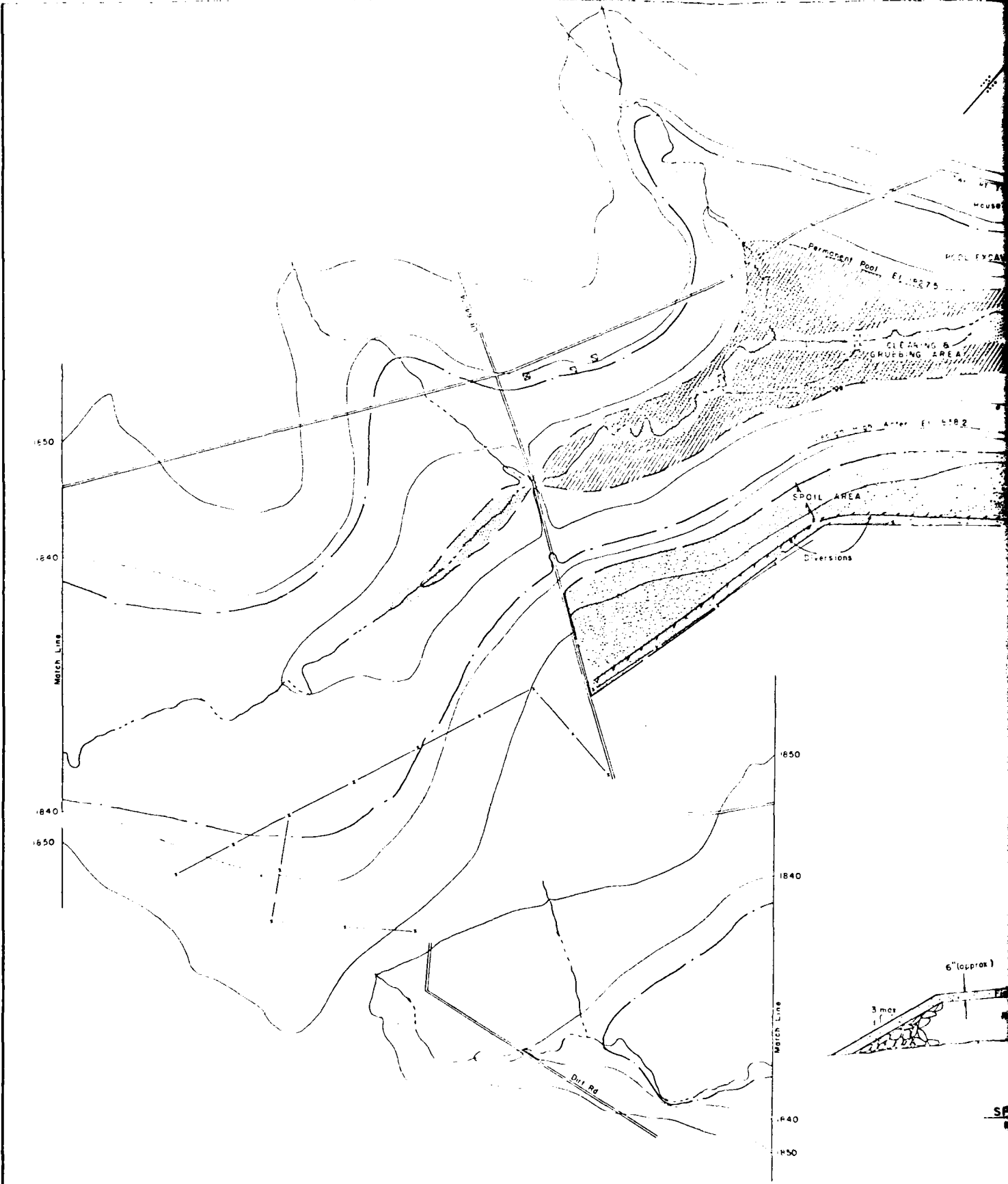

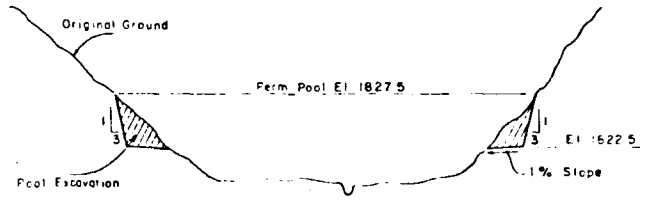
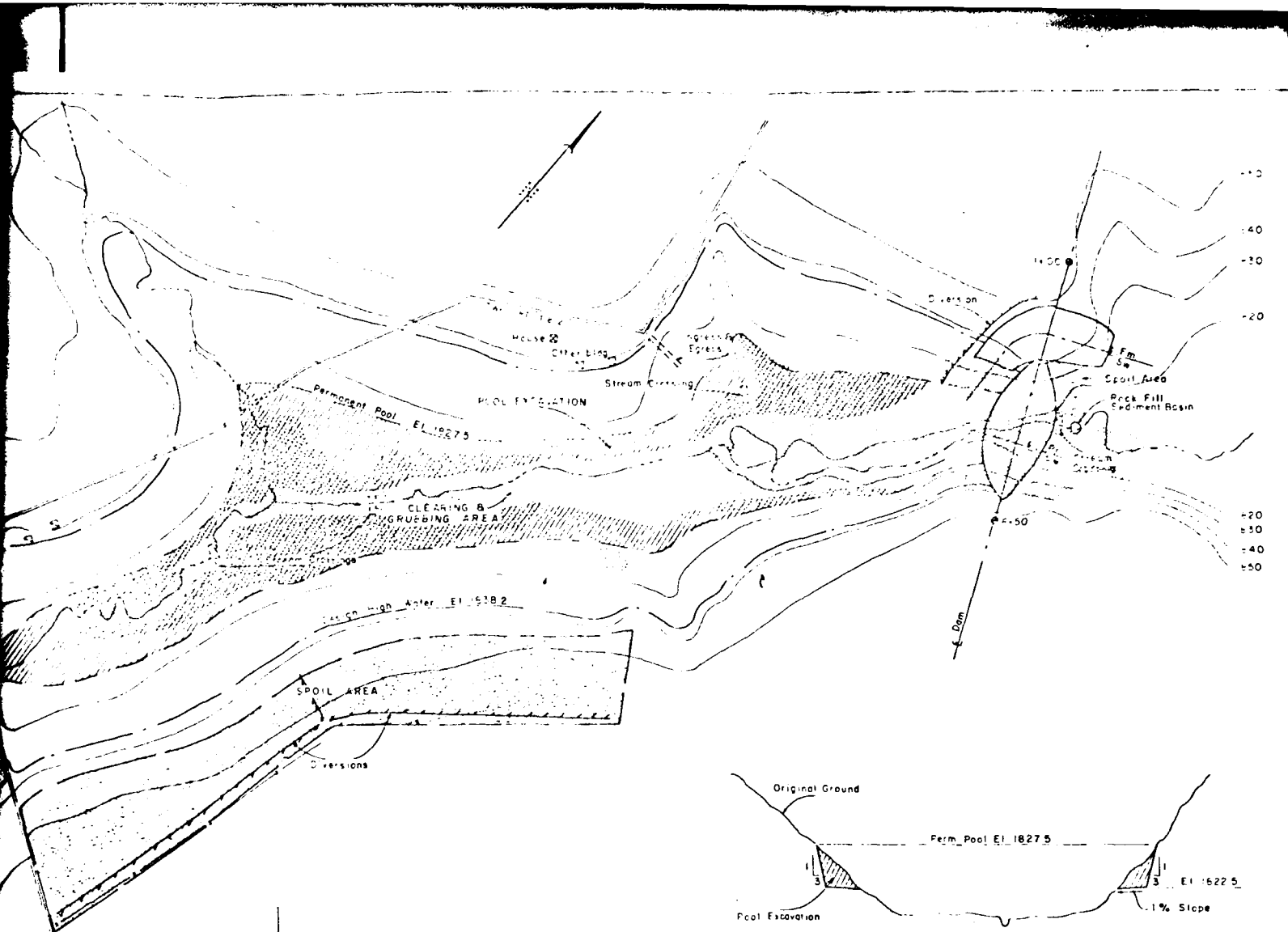

TYPICAL SECTION
POOL EXCAVATION
FROM 300' US E DAM TO (LR 64074)

CONSTRUCTION NOTES

- 1 Borrow to be obtained from within the pool excavation limits
- 2 Locations of stream crossings & rock fill sediment basins are approx
- 3 Clearing & grubbing as directed by the Engineer

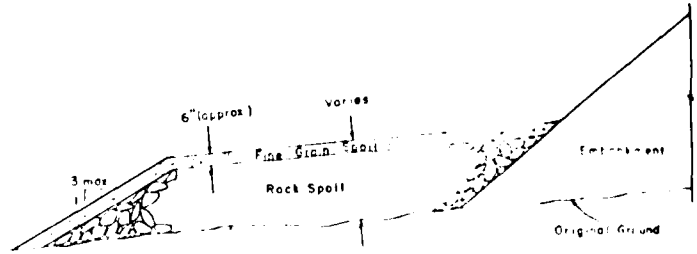

SPOIL DETAIL
NOT TO SCALE

Note: All spoil to be placed as directed by the Engineer

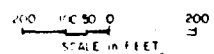

JACOBS CREEK WATERSHED
MULTIPLE PURPOSE DAM PA-657
WASHINGTON & FAYETTE COUNTIES, PENNSA
PLAN OF STORAGE AREA
U.S. DEPARTMENT OF AGRICULTURE
SOIL CONSERVATION SERVICE

DATE: 9-71
DRAWN BY: MERR
PA-657-P

FIGURE 2

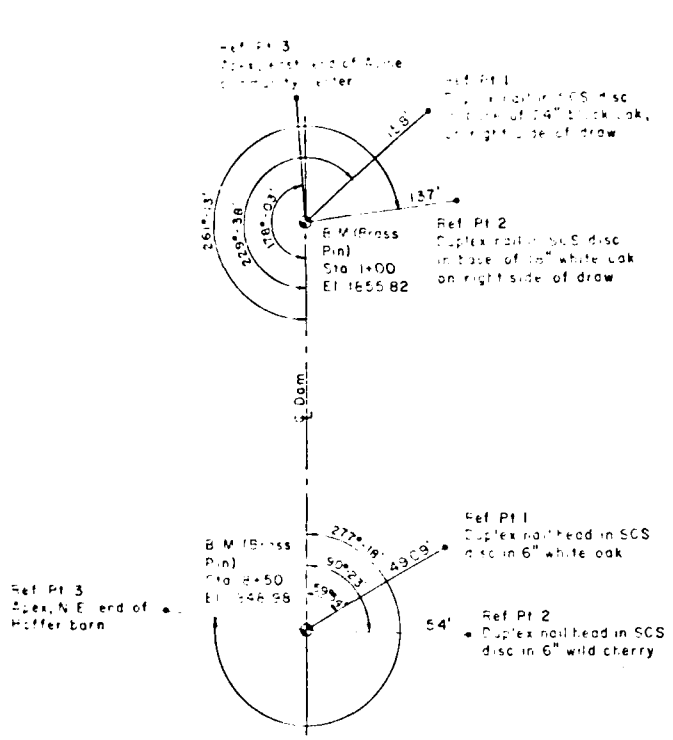

DAM LAYOUT

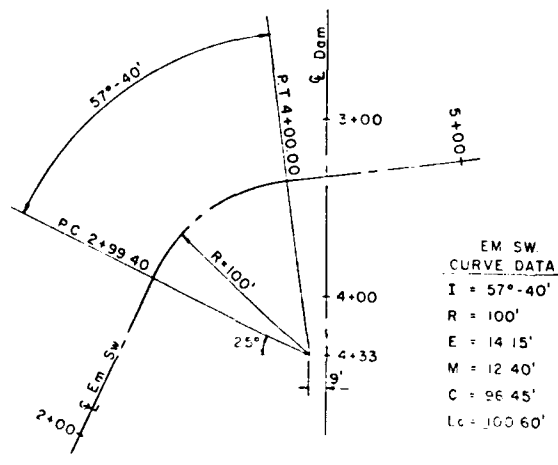

EMERGENCY SPILLWAY LAYOUT

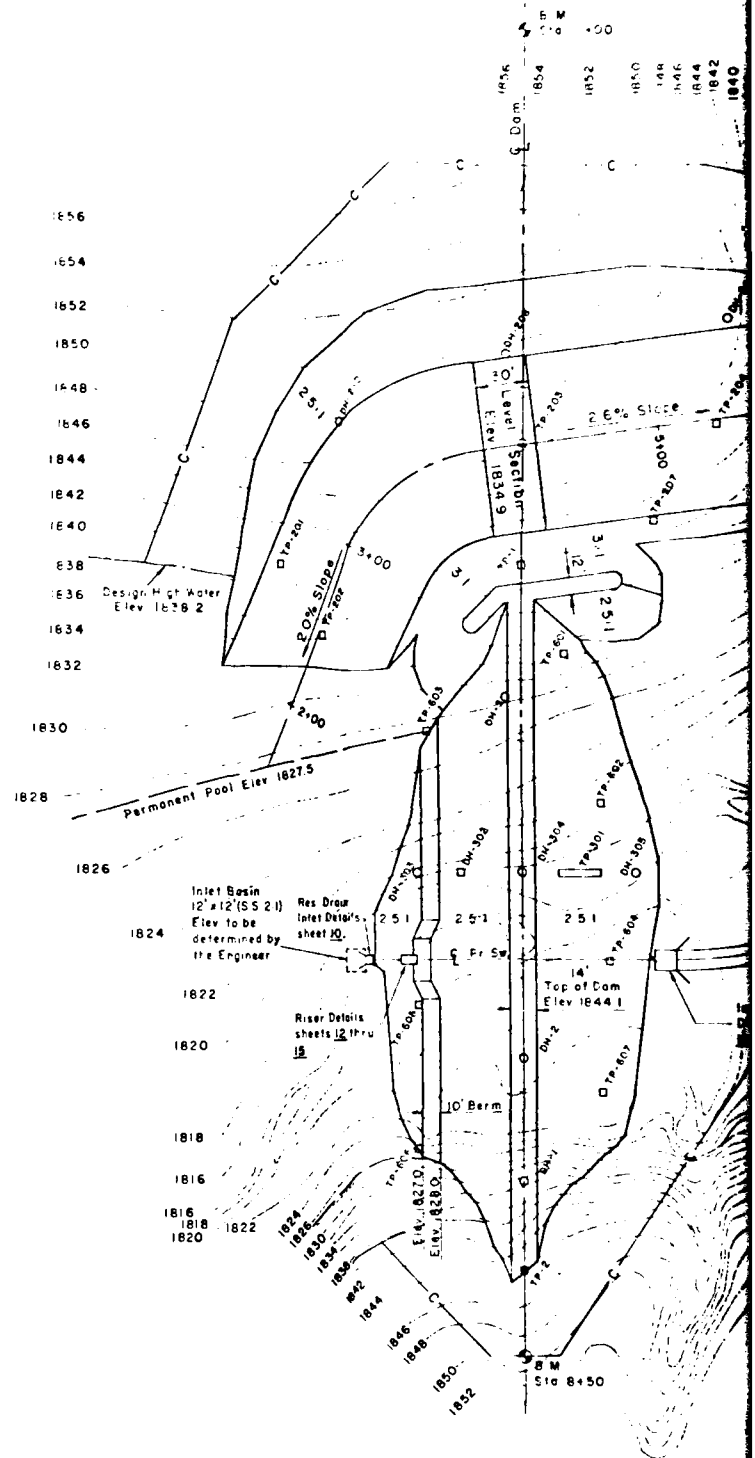

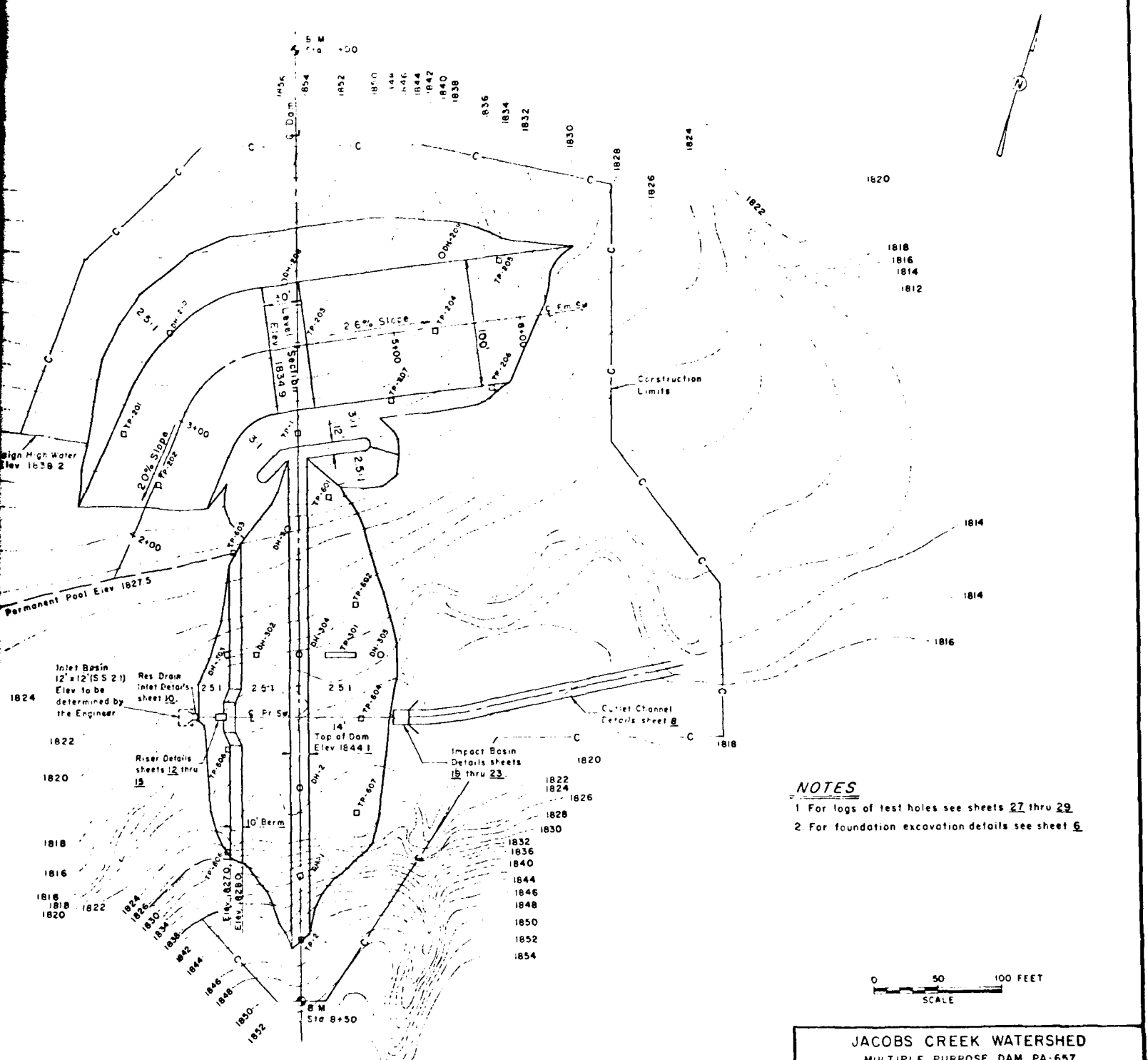

NOTES
 1 For logs of test holes see sheets 27 thru 29
 2 For foundation excavation details see sheet 6

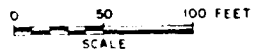

JACOBS CREEK WATERSHED
 MULTIPLE PURPOSE DAM PA-657
 WELLMORELAND & FAYETTE COUNTIES, PENNA
PLAN OF STRUCTURAL WORKS
 U. S. DEPARTMENT OF AGRICULTURE
 SOIL CONSERVATION SERVICE

Project	DATE	ASSIGNED BY
Drawn	TIME	
Checked		
Approved		
PA-657-P		

FIGURE 3

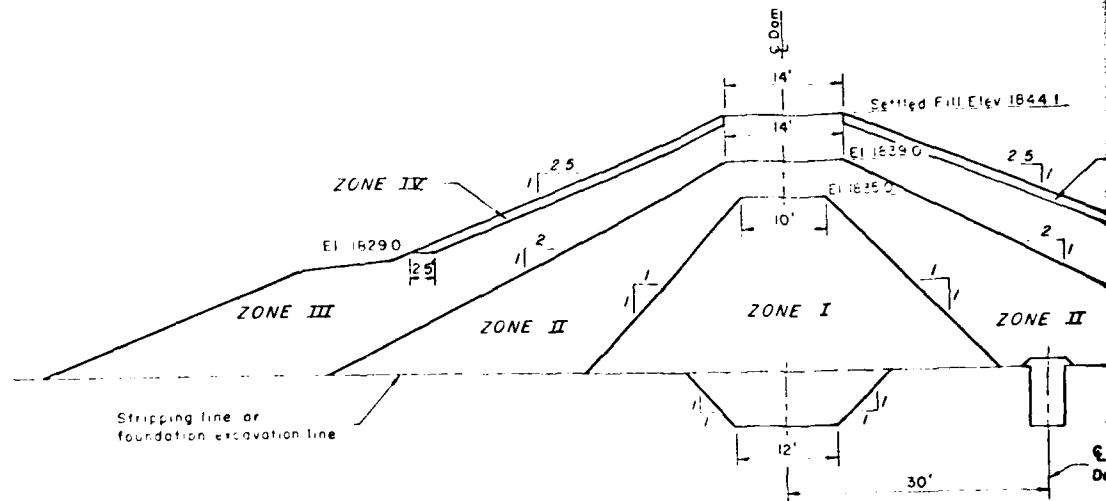

TYPICAL SECTION OF DAM

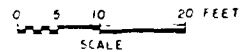

SELECTIVE PLACEMENT	MATERIAL	MAX ¹⁴ ROCK SIZE	MAX ¹¹ LIFT ¹⁴	REQ'D WATER CONTENT ¹²	COMPACTION ¹³	
					CLASS	DEFINITION
ZONE I	Material as represented by Lab. sample 71W1189, TP-102 (CL-ML)	6"	9"	Optimum - 1% to + 2%	A	95% Max. density by ASTM D-698, Method "A"
ZONE II	Material as represented by Lab. sample 71W1188, TP-201 (GM)	6"	9"	Optimum - 2% to + 2%	A	95% Max. density by ASTM D-698, Method "A"
ZONE III	Sandstone excavated from Emergency Spillway and oversized material raked from Zones I and II	12"	18"	As designated by the Engineer	C	Compact with min. six passes of 450 p.s.i. tamping roller per lift
ZONE IV	Topsoil	-	12"	As designated by the Engineer	C	Compact with at least one pass of 450 p.s.i. tamping roller or by an approved equivalent method

- ¹¹ Maximum permissible lift thickness before compaction
- ¹² Water content of fill matrix at time of compaction. Variation from water content shown may be approved by the Engineer
- ¹³ For typical compaction curves, see sheet 30
- ¹⁴ For hard compacted backfill, the max. rock size and lift thickness shall not exceed one half of the size and thickness shown

CONS

1 Con

2 For see

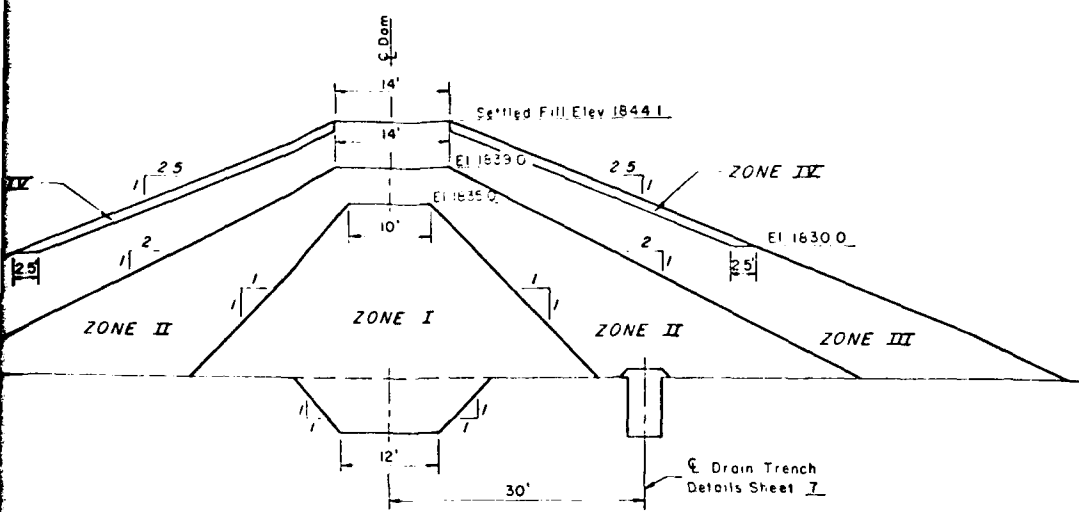

TYPICAL SECTION OF DAM

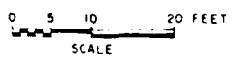

REQ'D WATER CONTENT	COMPACTION	
	CLASS	DEFINITION
Optimum - 1% ± 2%	A	95% Max density by ASTM D-698, Method "A"
Optimum - 2% ± 2%	A	95% Max density by ASTM D-698, Method "A"
Designated by the Engineer	C	Compact with min. six passes of 450 p.s.i. tamping roller per lift
Designated by the Engineer	C	Compact with at least one pass of 450 p.s.i. tamping roller or by an approved equivalent method

CONSTRUCTION NOTES

- Constructed Slopes are:
2.43:1 Upstream
2.43:1 Downstream
- For constructed fill elevations see sheet 6.

JACOBS CREEK WATERSHED
 MULTIPLE PURPOSE DAM PA-657
 WESTMORELAND & FAYETTE COUNTIES, PENNA.
 FILL PLACEMENT

U. S. DEPARTMENT OF AGRICULTURE
 SOIL CONSERVATION SERVICE

Designed	Date	Approved by
Drawn RAS	8-71	
Checked		
Project		
Project No.		
PA-657-P		

FIGURE 4

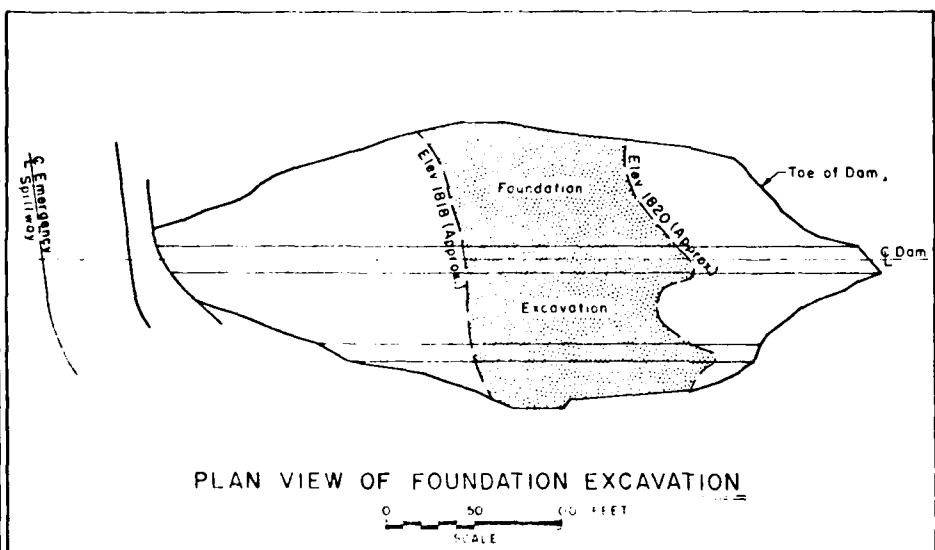
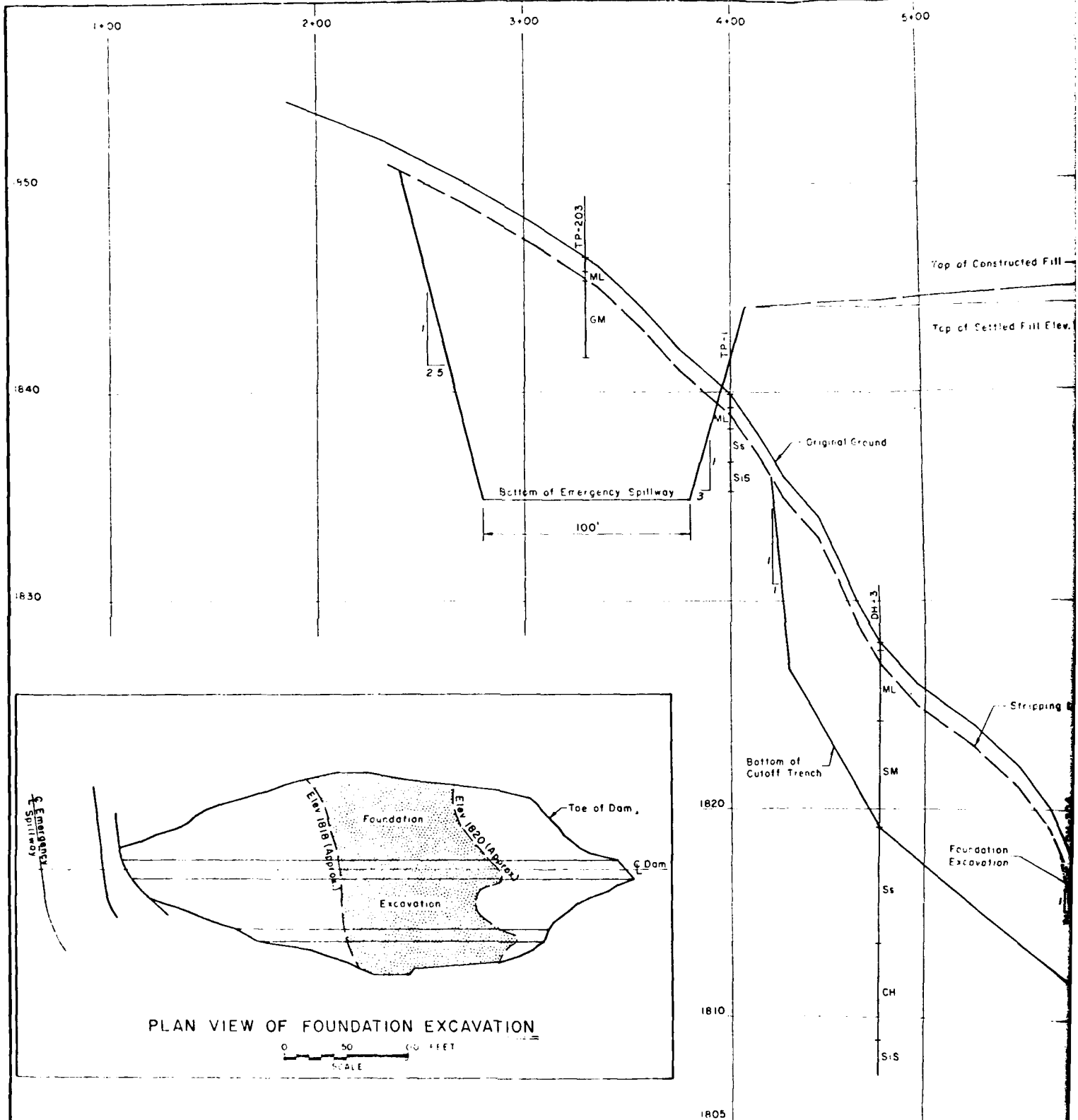

CONSTRUCTION NOTES

1. For logs of test holes see sheet 27 thru 29
2. E Dam = E Cutoff trench
3. For foundation excavation limits see plan view on this sheet

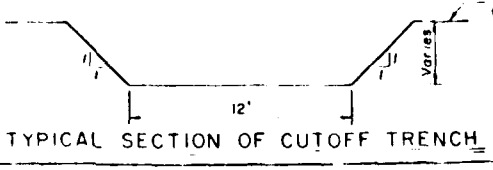

PROFILE ALONG

Stripping line or foundation excavation line

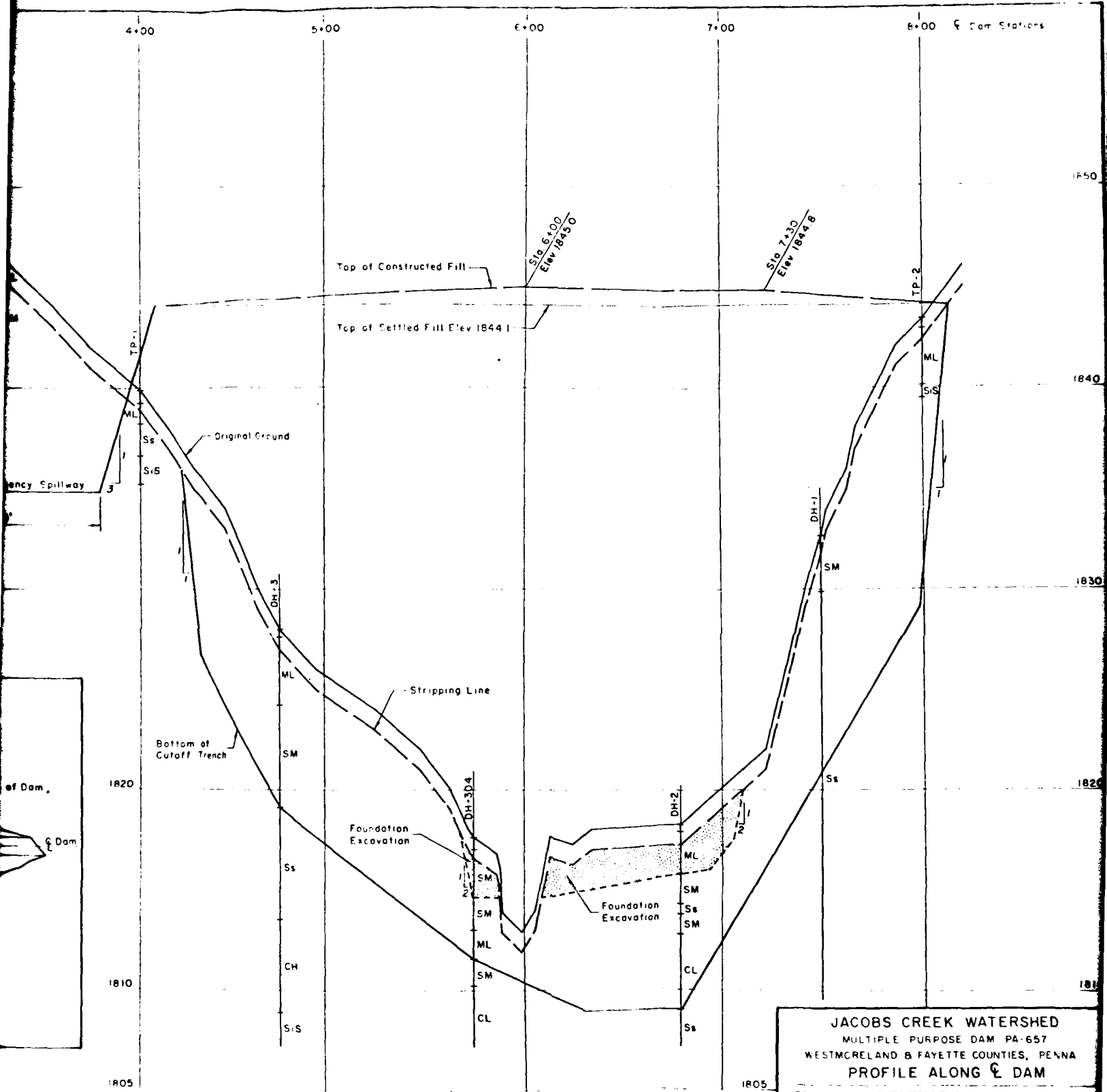

PROFILE ALONG CENTERLINE OF DAM

JACOBS CREEK WATERSHED
 MULTIPLE PURPOSE DAM PA-657
 WESTMORELAND & FAYETTE COUNTIES, PENNA.
 PROFILE ALONG C.D. DAM

U. S. DEPARTMENT OF AGRICULTURE
 SOIL CONSERVATION SERVICE

Designed	Date	Approved
Drawn RAS	8-71	Title
Checked		Scale
Drawn		Sheet No.
		Project No.
		PA-657-P

APRIL

FIGURE 5

GRADATION LIMITS FOR DRAIN FILL

SEIVE NO.	% PASSING (Based on Dry Weight)
1/2"	100
3/8"	75 - 100
no. 4	10 - 30
no. 8	0 - 10
no. 16	0 - 5
no. 200	< 3

SEIVE NO.	% PASSING (Based on Dry Weight)
3/8"	100
no. 4	90 - 100
no. 8	70 - 92
no. 16	50 - 80
no. 30	30 - 65
no. 50	10 - 30
no. 100	1 - 8
no. 200	< 3

QUANTITY SUMMARY

- 2 - 6' Sections
- 12 - 20' Sections
- 2 - 1' x 1' Elbows, 90°
- 2 - 3'-5" x 2'-10" Elbows, 90°
- 2 - 1' x 2' Elbows, 90°
- 2 - 1'-1" x 2'-6" Elbows, 90°
- 2 - Small Animal Guards (sh. 16.)
- 2 - Metal End Caps

281' - 8" - Total

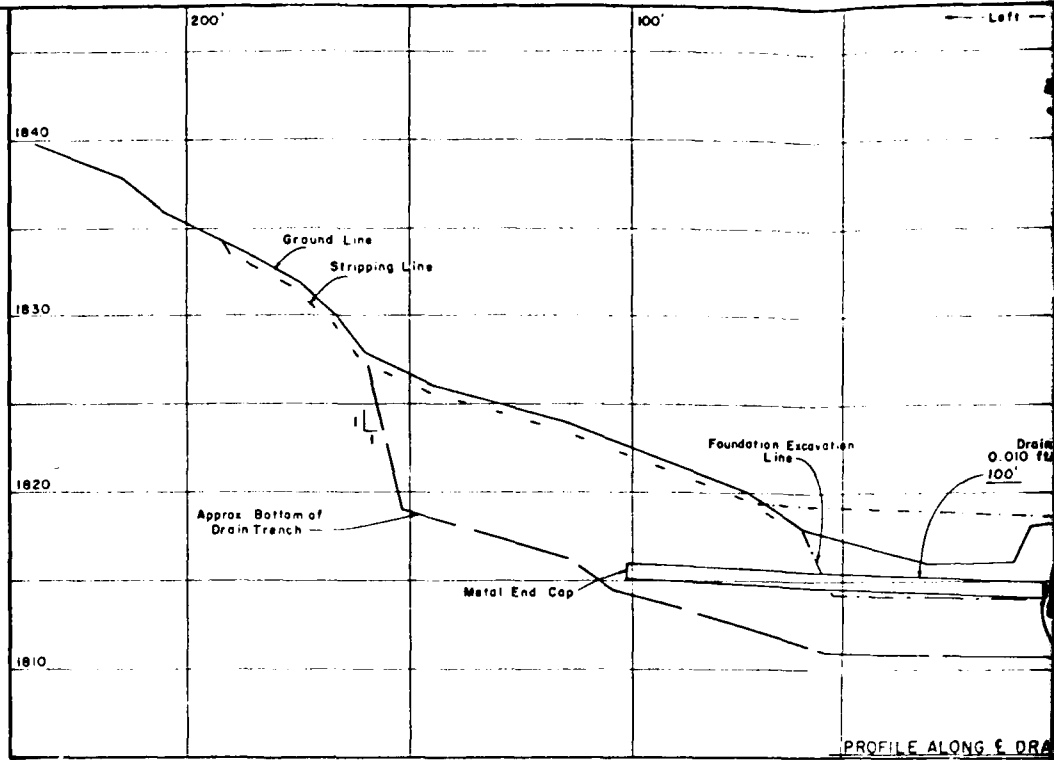

PROFILE ALONG CENTERLINE OF DRAIN

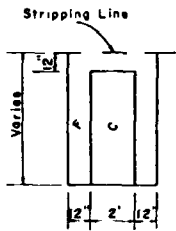

SECTION A-A

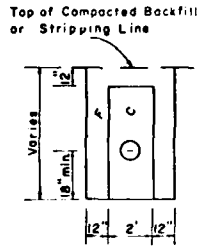

SECTION B-B

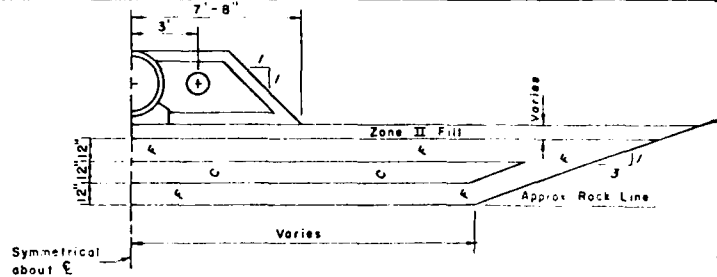

Symmetrical about centerline

SECTION C-C

Typical from Sta 6+26 92 to Sta 6+74 42 @ Principal Spillway

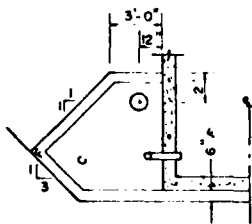

SECTION D-D

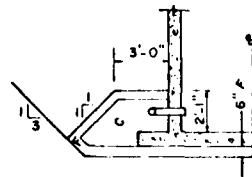

SECTION E-E

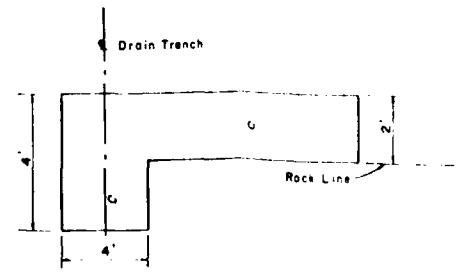

TYPICAL SECTION - BLANKET DRAIN

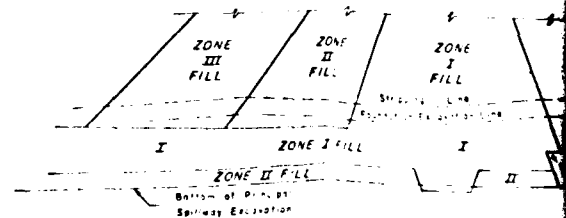

SECTION F-F

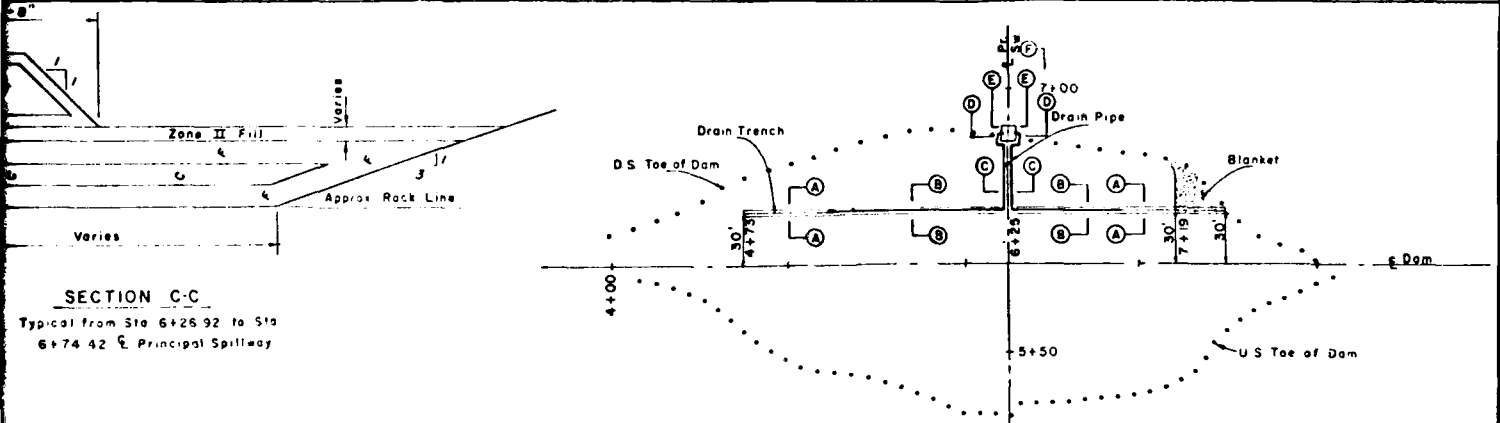
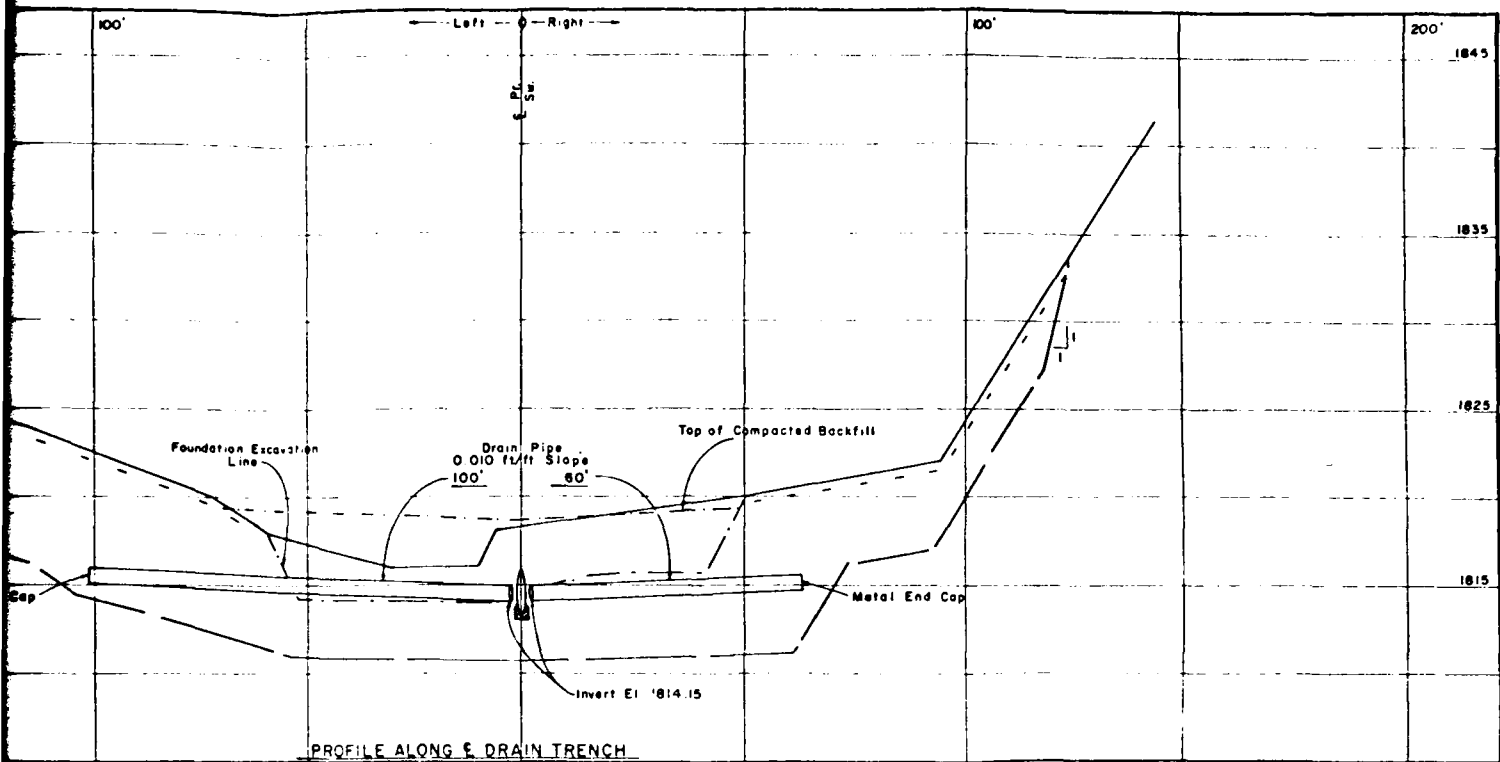

SECTION C-C
 Typical from Sta 6+26.92 to Sta
 6+74.42 of Principal Spillway

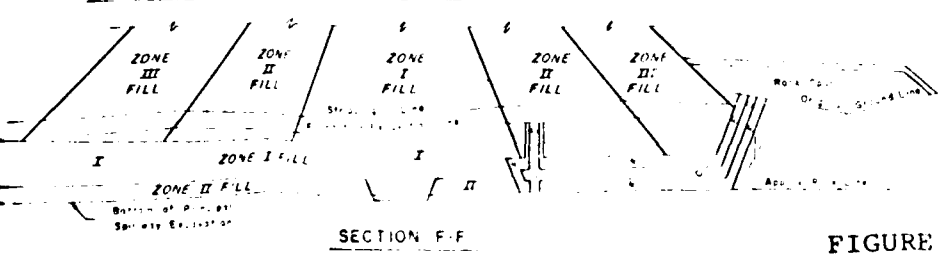
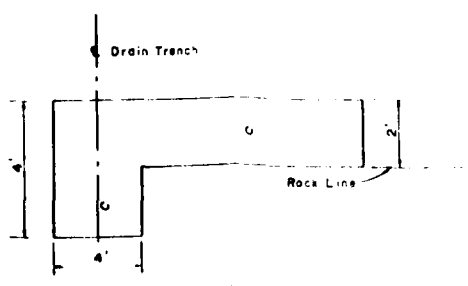

CONSTRUCTION NOTE
 G = Coarse Drain Fill
 & = Fine Drain Fill
 All drain pipe shall 12" dia., Class I, Shape I,
 Coating G, 16 Gage, Perforated (Spec 551)

REVISIONS		
Date	Item	Approved
9-21-73	Replaces Sheet 7 of 30	<i>[Signature]</i>

**JACOBS CREEK WATERSHED
 MULTIPLE PURPOSE DAM PA-657
 WESTMORELAND & FAYETTE COUNTIES, PENNA
 DRAINAGE**

**U. S. DEPARTMENT OF AGRICULTURE
 SOIL CONSERVATION SERVICE**

Date	10-71
Drawn	CHISH
Checked	<i>[Signature]</i>
Date	10-71
Approved	<i>[Signature]</i>
Project No.	PA-657-P

FIGURE 6

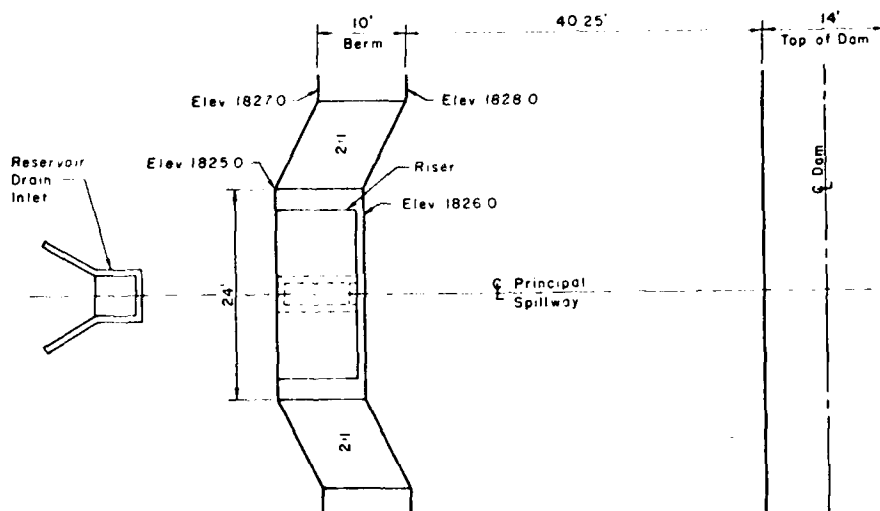

PLAN

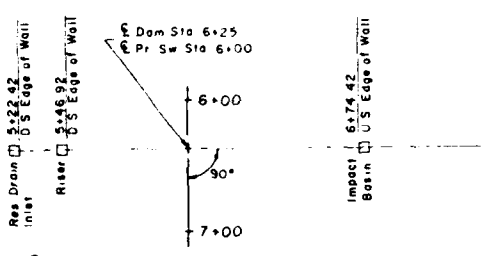
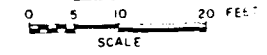

PRINCIPAL SPILLWAY LAYOUT

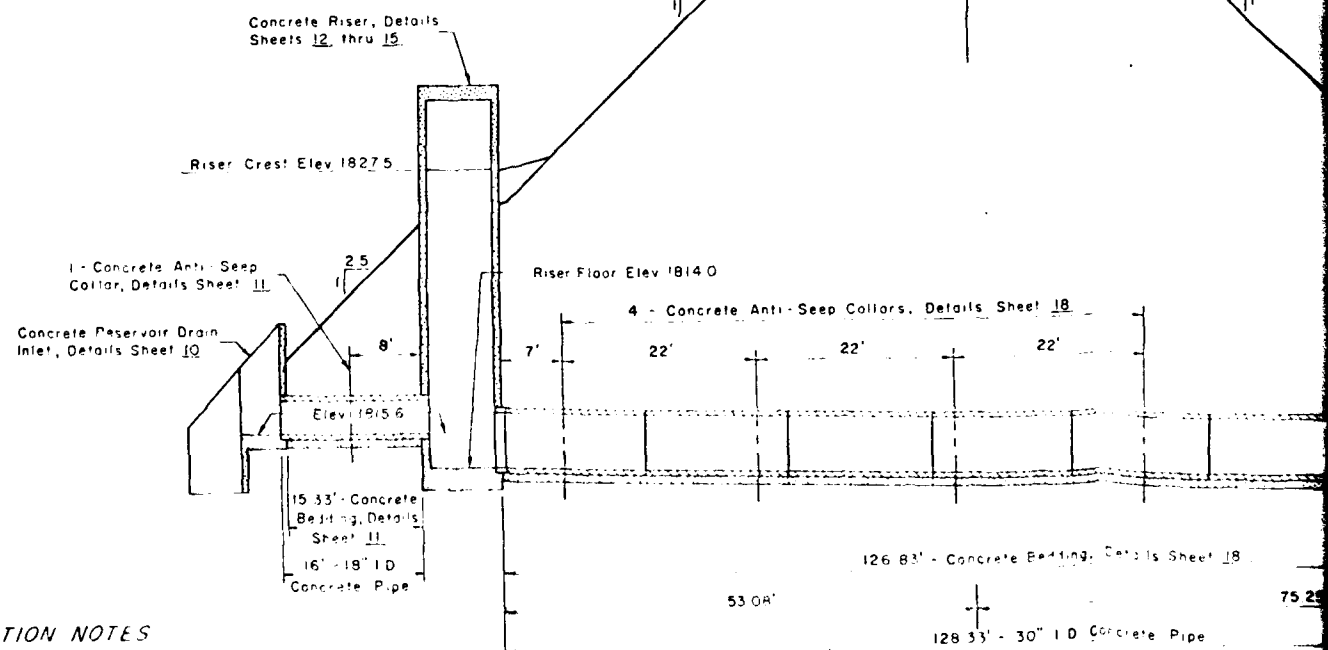

CONSTRUCTION NOTES

- Outlet end of 30" pipe (up joint end) and inlet end of 18" pipe (down joint end) to be finished so that no materials exposed.
- Pipe layout data will be furnished by the Engineer.
- Riser bedding shall meet fine drain fill gradation limits. (Sheet 7)
- Layout sketches for 16" and 18" sections of 2" sections are used, quantities and some dimensions will change.



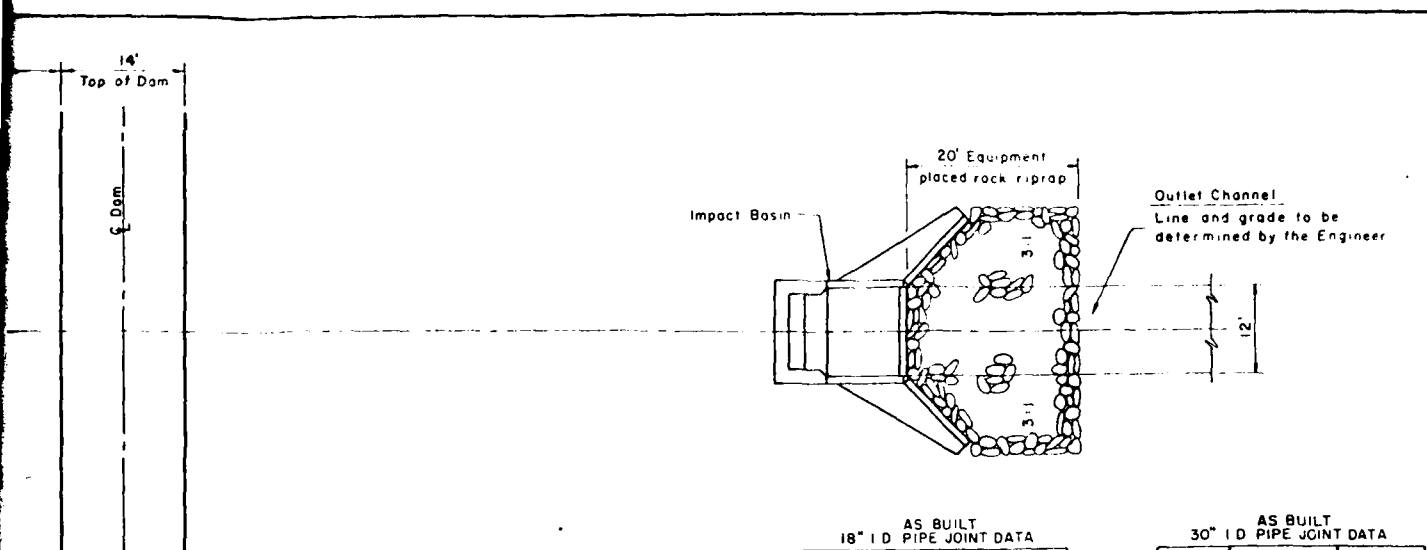

PLAN

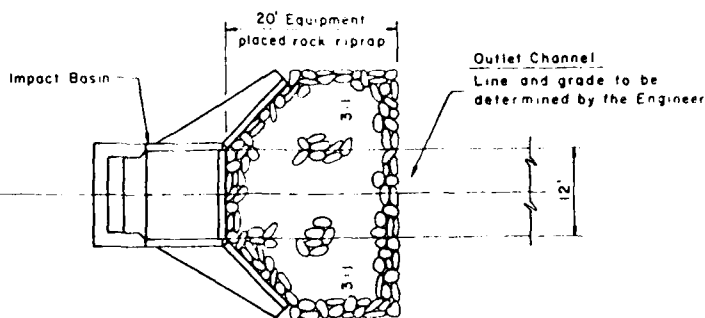
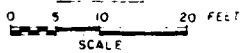

**AS BUILT
18" I.D. PIPE JOINT DATA**

JOINT	DIST FROM RISER WALL	INVERT EL

**AS BUILT
30" I.D. PIPE JOINT DATA**

JOINT	DIST FROM RISER WALL	INVERT EL

**AS BUILT COLLAR DATA
FOR 18" I.D. PIPE**

COLLAR	DIST FROM RISER WALL	INVERT EL

**AS BUILT COLLAR DATA
FOR 30" I.D. PIPE**

COLLAR	DIST FROM RISER WALL	INVERT EL

18" I.D. Reinforced Concrete Pressure Pipe, Steel Cylinder Type, Spec 541 (AWWA C-300 or C-301)

- 16' - Straight section
- 1 - Bell and flange wall fitting (for 10" wall)
- 16' - TOTAL

30" I.D. Reinforced Concrete Pressure Pipe, Steel Cylinder Type, Spec 541 (AWWA C-300 or C-301)

- 128' - Straight sections
- 1 - Spigot ring wall fitting
- 128'33" - TOTAL

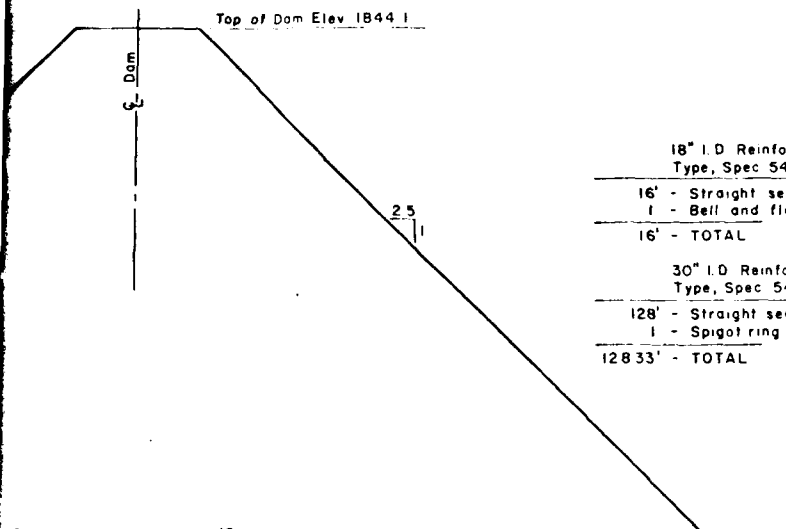

Collars, Details Sheet 18

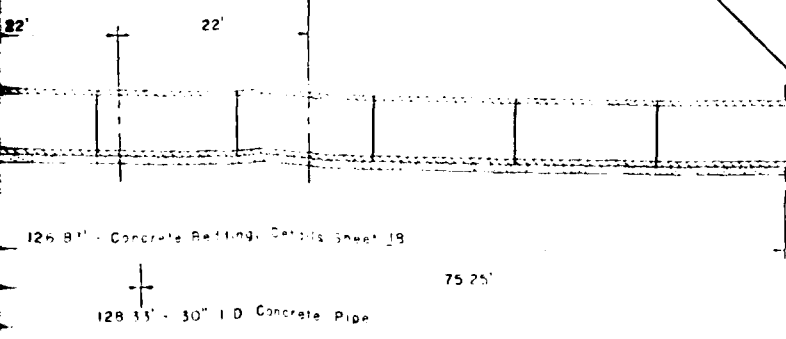

Concrete Impact Basin, Details Sheets 19, thru 23

Invert Elev 1813.2

126.81' - Concrete Bell, Details Sheet 19

128'33" - 30" I.D. Concrete Pipe

ONG CENTERLINE PRINCIPAL SPILLWAY

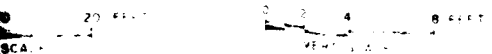

JACOBS CREEK WATERSHED
 MULTIPLE PURPOSE DAM PA 657
 WESTMORELAND & FAYETTE COUNTIES, PENNA
PRINCIPAL SPILLWAY
 U. S. DEPARTMENT OF AGRICULTURE
 SOIL CONSERVATION SERVICE

DATE: 7-71
 BY: R. A. STALTER

PA-657-P

FIGURE 7

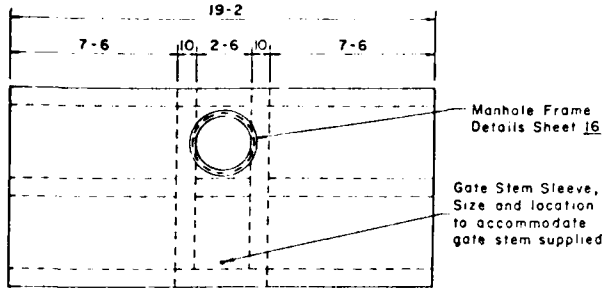

PLAN-TOP

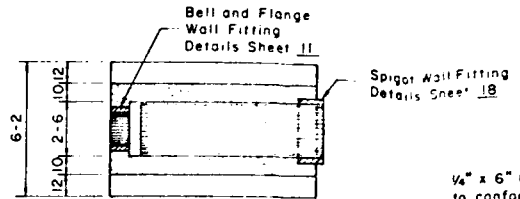

SECTION B-B

1/4" x 6" Carbon steel plate to conform to Spec 581. Continuous thru constr. joint

Splices shall be either
 1. Butt welded
 2. Lapped 3" and bolted.
 3. Lapped 3" and fillet welded

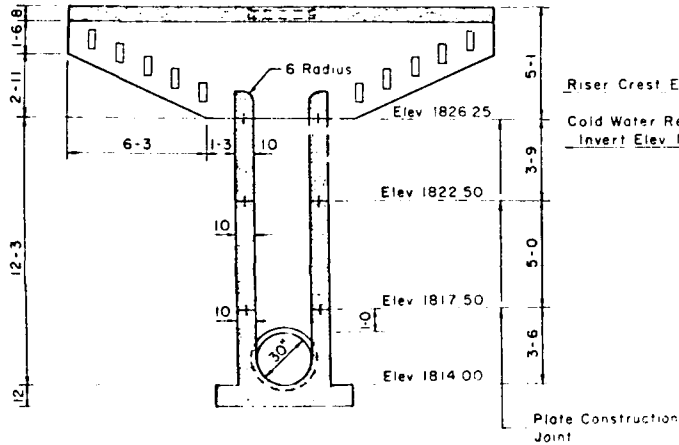

SECTION A-A

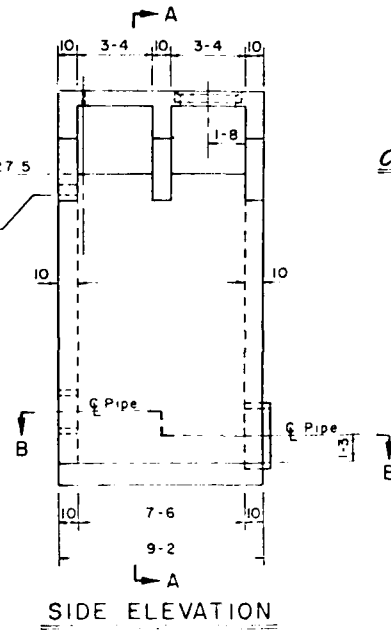

SIDE ELEVATION

PLATE CONSTR JOINT

1
2
3
4
5
6
7
8

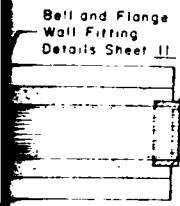

Bell and Flange Wall Fitting Details Sheet 11
Spigot Wall Fitting Details Sheet 18

1/4" x 6" Carbon steel plate, to conform to Spec. 181 Continuous thru constr. joint.
Splices shall be either
1 Butt welded
2 Lapped 3" and bolted
3 Lapped 3" and fillet welded

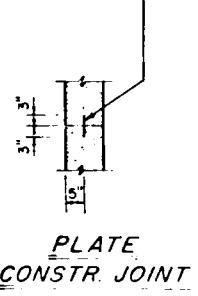
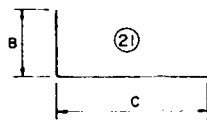
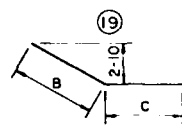
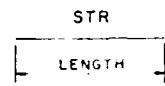

PLATE CONSTR. JOINT



BAR TYPES

QUANTITIES (Riser Only)

STEEL

No 5 Bars 3089.5 Ft = 3221.3 Lbs
No 7 Bars 157.5 Ft = 321.9 Lbs
3543.2 Lbs

CONCRETE

Class 4000 22.2 Cu Yds Reinforced

NOTES

- 1 Portland Cement type I-A or I with an air-entraining admixture shall be used.
- 2 When not otherwise shown, thickness of concrete over reinforcing steel shall be 2" in formed surfaces and 3" in unformed surfaces.
- 3 All exposed edges of concrete to have a 1" chamfer unless otherwise noted.
- 4 Bar dimensions are out to out of bar.
5. Trash rack details sheet 16.
6. Cold water release details sheet 17.
7. Slide gate notes sheet 15.
8. Round bottom of riser to stop 5" from inside of upstream endwall.

RISER STEEL SCHEDULE

MARK	SIZE	QUANTITY	LENGTH	TYPE	B	C	TOTAL LENGTH
B 1	5	10	5-9	STR			57-6
B 2	5	7	8-9	STR			61-3
B 3	7	18	8-9	21	3-0	5-9	157-6
B 4	5	6	8-9	STR			52-6
B 5	5	1	8-0	STR			8-0
B 6	5	9	5-3	STR			51-9
B 7	5	2	2-3	STR			4-6
B 8	5	5	6-9	21	1-0	5-9	33-9
B 9	5	17	6-9	21	1-0	5-9	114-9
B 10	5	8	8-3	STR			66-0
B 11	5	4	3-3	STR			13-0
B 12	5	3	2-3	STR			6-9
B 13	5	3	2-3	STR			6-9
B 14	5	8	5-9	21	0-6	5-3	46-0
B 15	5	12	8-0	21	2-9	5-3	96-0
B 16	5	8	2-9	STR			22-0
R 1	5	40	6-9	STR			270-0
R 2	5	18	8-3	STR			148-6
R 3	5	14	3-3	STR			45-6
R 4	5	48	8-0	21	2-9	5-3	384-0
R 5	5	12	5-6	STR			66-0
R 6	5	14	4-10	STR			67-8
R 7	5	14	4-8	STR			65-4
T 1	5	6	7-0	STR			42-0
T 2	5	6	12-6	STR			75-0
T 3	5	6	18-0	STR			108-0
T 4	5	6	18-9	STR			112-6
T 5	5	12	8-6	19	1-9	6-9	102-0
T 6	5	12	2-3	STR			27-0
T 7	5	12	3-0	STR			36-0
T 8	5	12	3-6	STR			42-0
T 9	5	12	4-3	STR			51-0
T 10	5	20	4-6	STR			90-0
T 11	5	16	4-9	STR			76-0
T 12	5	6	8-9	STR			52-6
T 13	5	32	8-3	STR			280-0
T 14	5	4	5-0	STR			20-0
T 15	5	12	18-3	STR			225-0
T 16	5	8	7-3	STR			62-0

SECTION B-B

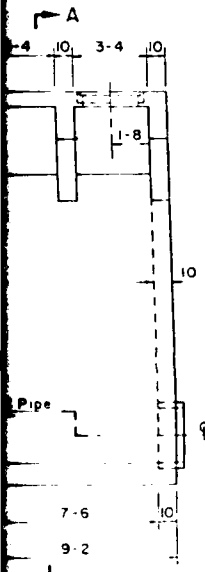

ELEVATION

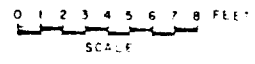

JACOBS CREEK WATERSHED
MULTIPLE PURPOSE DAM PA 657
WESTMORELAND AND FAYETTE COUNTIES, PENNSA
RISER STRUCTURAL DETAILS
U. S. DEPARTMENT OF AGRICULTURE
SOIL CONSERVATION SERVICE

PA-657-P

FIGURE 8

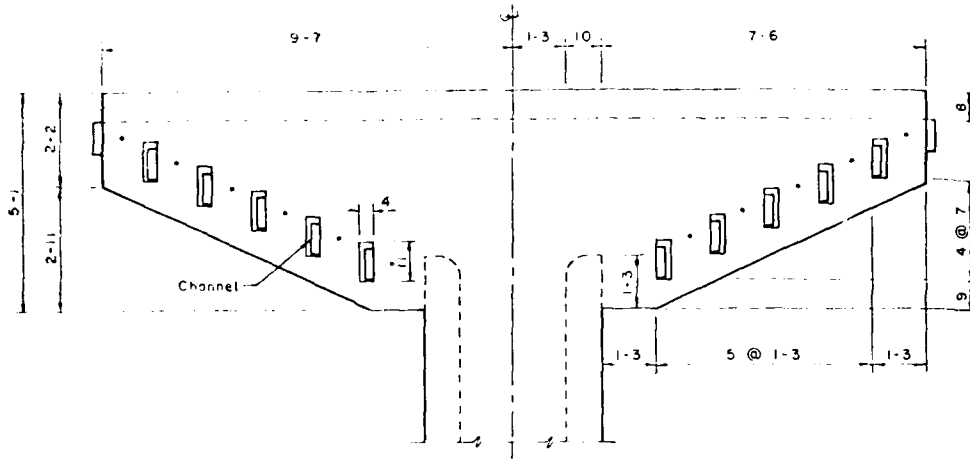

SPLITTER WALL ELEVATION

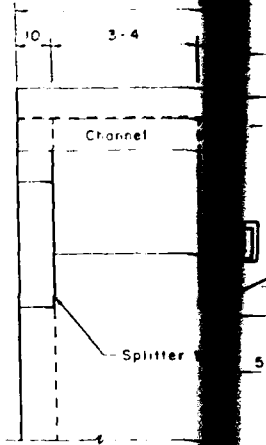

ENDWALL

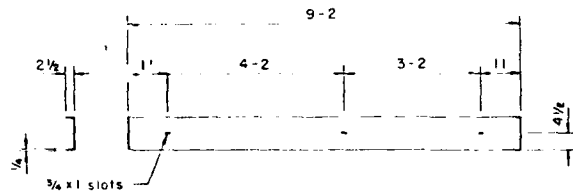

CHANNEL

BILL OF	
ITEM	QTY
Channel	2 1/2
Pipe Sleeves	3/4"
"L" Bolt	3/4"

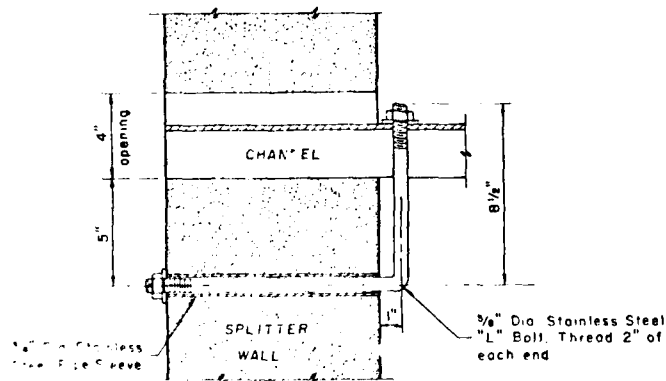

"L" BOLT DETAIL

SUPPLY WITH HEX NUTS AND FLAT WASHERS ASTM A-276

CONSTRUCTION

1. Channel in track Spec 581 for
2. Aluminum surface with crests of an alkali-res before install

RISER TRASH

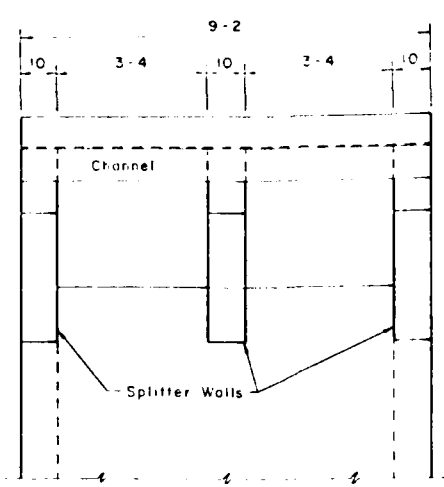
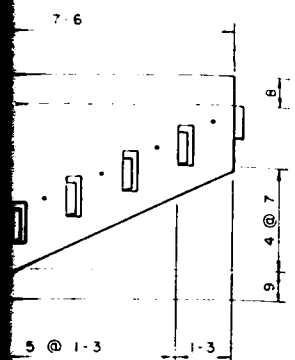

ENDWALL ELEVATION

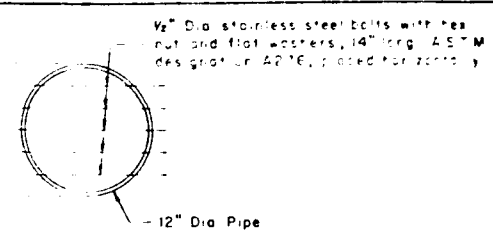

Note
Drill holes for bolts
3" from end of pipe

SMALL ANIMAL GUARD
2 REQUIRED

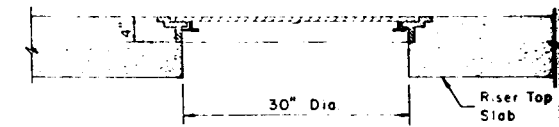

MANHOLE ASSEMBLY

1. THE ASSEMBLY SHALL BE GREY IRON CASTING, CLASS 30, WITH A 30" OPENING.
2. THE LIFTING DEVICE SHALL CONSIST OF A 1" DIA. HOLE AFFR X, 3" FROM THE OUTSIDE PERIMETER OF THE LID.
3. THE LOCKING DEVICE SHALL CONSIST OF TWO ROTATING BARS WITH HEX BOLTS LOCATED UNDER OPPOSITE EDGES OF THE LID.
4. PAINT IN ACCORDANCE WITH PAINT SYSTEM A. (SPEC. 82)

BILL OF MATERIAL			
ITEM	SIZE	LENGTH	QUANTITY
Channel	2 1/2" x 9"	9'-2"	12
Pipe Sleeve	3/4" Dia	0'-10"	36
"L" Bolt	3/8" Dia	8 1/2" x 12"	36

CONSTRUCTION NOTES

1. Channel in trash rack shall conform to Spec 581 for aluminum alloy.
2. Aluminum surfaces to be placed in contact with concrete, shall be given a heavy coat of an alkali-resistant bituminous paint before installation.

SLIDE GATE NOTES

1. SLIDE GATE, 18" DIA., TYPE MMS-2 (MATERIAL SPEC. 572)
2. CLASS 5-15, FLAT BACK FRAME.
3. BELL AND FLANGE, WALL FITTING, 10" DEEP, ROUND OPENING. DRAW AN TAP TO ACCOMMODATE GATE.
4. FULLY ADJUSTABLE STEM GUIDES.
5. NON-RISING, STAINLESS STEEL STEM. STEM GUIDES AND GATE LIFT DEVICE SIZE AND SPACED ACCORDING TO MANUFACTURERS RECOMMENDATIONS.
6. PAINT IN ACCORDANCE WITH PAINT SYSTEM A. (SPEC. 82)
7. DISTANCE FROM CENTERLINE OF GATE TO TOP OF RISER COVER SLAB = 15.08'

RISER TRASH RACK

3/8" Dia Stainless Steel
"L" Bolt Thread 2" of each end

JACOBS CREEK WATERSHED
MULTIPLE PURPOSE DAM PA-657
WESTMORELAND AND FAYETTE COUNTIES, PENNA.
RISER ACCESSORIES
U. S. DEPARTMENT OF AGRICULTURE
SOIL CONSERVATION SERVICE

Designed	Date	Approved By
Drawn R. A. STALTER	8-71	Title
Checked	Date	Checked By
Checked John Featherman 10/7/71		
Drawing No.		PA-657-P

FIGURE 9

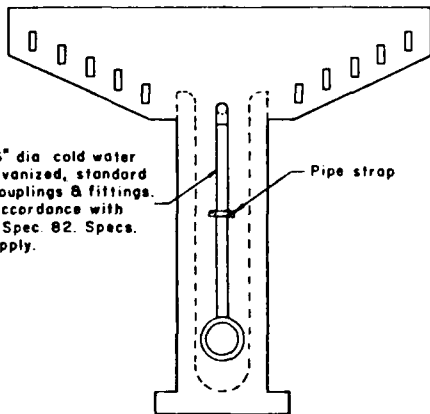

Approx. 1125' of 6" dia cold water release pipe, galvanized, standard weight, flanged couplings & fittings. Paint outside in accordance with paint system G - Spec. 82. Specs. 553 and 582 apply.

Pipe strap

UPSTREAM ELEVATION

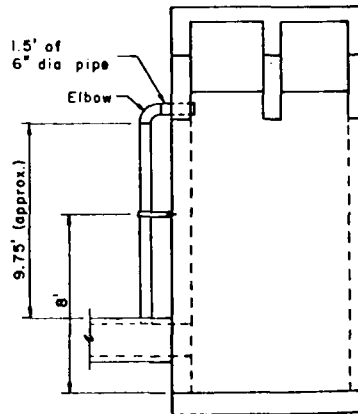

1.5' of 6" dia pipe

Elbow

9.75' (approx.)

8'

SIDE ELEVATION

PIP
1 P
co
2 A
3 St
in
wi
4 P

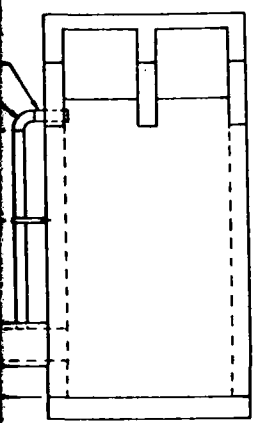

SIDE ELEVATION

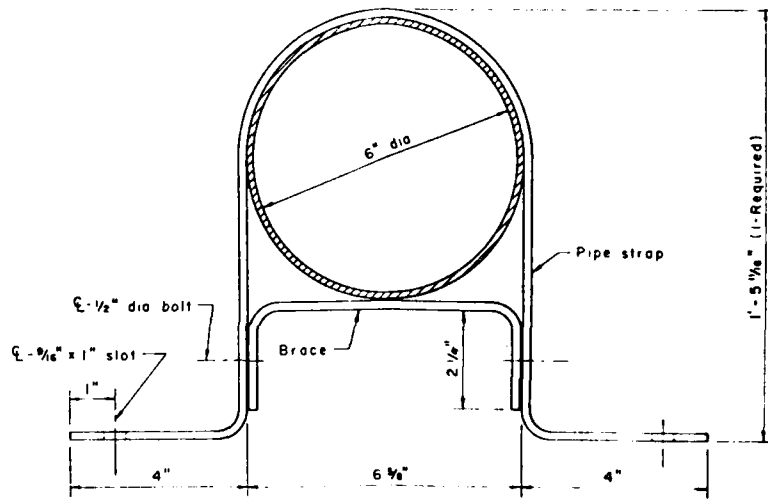

STRAP DETAIL

PIPE STRAP NOTES

1. Pipe straps and braces are $\frac{3}{8}$ " x 3" and shall conform to Spec 581 for structural carbon steel plates
2. All 90° bends are $\frac{1}{2}$ " radius
3. Straps, braces, bolts, nut and washers to be galvanized in accordance with Spec 582, and painted in accordance with paint system G - Spec 82
4. Pipe straps fastened to riser by $\frac{1}{2}$ " dia expansion bolts

NOT TO SCALE

JACOBS CREEK WATERSHED
 MULTIPLE PURPOSE DAM PA-657
 WESTMORELAND & FAYETTE COUNTIES, PENNA
COLD WATER RELEASE
U. S. DEPARTMENT OF AGRICULTURE
SOIL CONSERVATION SERVICE

R. A. STALTER 9-71
 PA-657-P

FIGURE 10

APPENDIX G
REGIONAL VICINITY
AND
WATERSHED BOUNDARY MAP

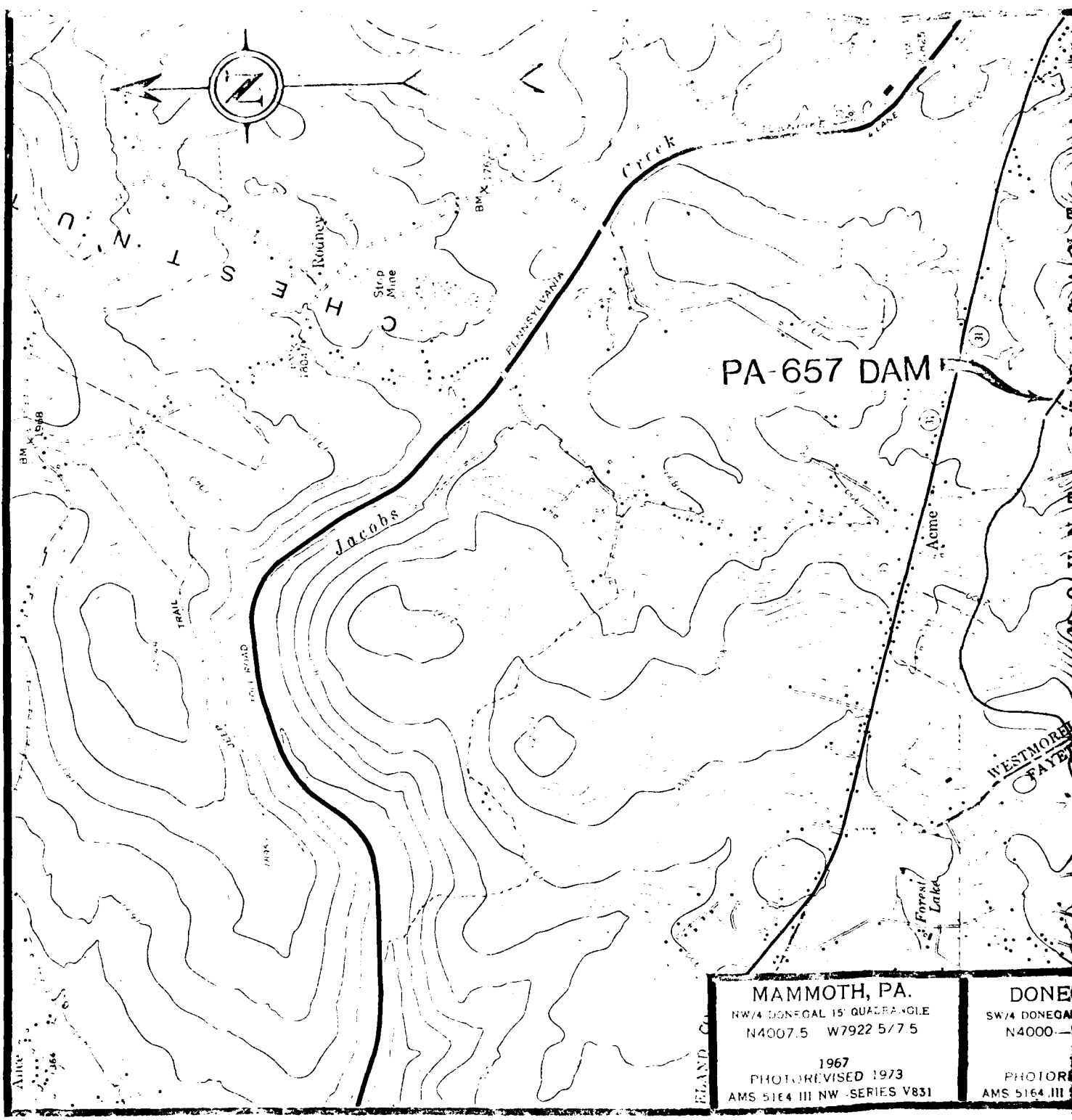

PA-657 DAM

<p>MAMMOTH, PA. NW/4 DONEGAL 15' QUADRANGLE N4007.5 W7922 5/7 5</p> <p>1967 PHOTO REVISÉD 1973 AMS 51E4 III NW -SERIES V831</p>	<p>DONEGAL SW/4 DONEGAL N4000—</p> <p>PHOTO AMS 51E4.III</p>
--	--

PA-657 DAM

MOUNT PLEASANT

WESTMORELAND CO
FAYETTE CO

WATERSHED BOUNDARY

MAMMOTH, PA.

NW/4 DONEGAL 15' QUADRANGLE
N4007.5 W7922.5/7.5

1967
PHOTO REVISÉD 1973
AMS 5164 III NW SERIES V831

DONEGAL, PA.

SW/4 DONEGAL 15' QUADRANGLE
N4000 W7922.5/7.5

1967
PHOTO REVISÉD 1973
AMS 5164 III SW SERIES V831

--- LONGEST WATERCOURSE

⊙ CENTROID OF DRAINAGE AREA

2