

AD-A079 403

AIR FORCE OCCUPATIONAL MEASUREMENT CENTER RANDOLPH AFB TX F/6 5/9  
CORROSION CONTROL CAREER LADDER. AFSC 427X1.(U)  
NOV 79

UNCLASSIFIED

NL

[ of ]  
AD-A  
079403

END  
DATE  
FILMED  
2 -80  
DPC

LEVEL II  
OCCUPATIONAL SURVEY REPORT

ADA 079403



DDO  
REGISTRATION  
JAN 15 1980  
E

DDC FILE COPY

CORROSION CONTROL CAREER LADDER  
AFSC 427X1

AFPT 90-427-385

NOVEMBER 1979

12681

OCCUPATIONAL SURVEY BRANCH  
USAF OCCUPATIONAL MEASUREMENT CENTER  
RANDOLPH AFB TEXAS 78148

APPROVED FOR PUBLIC RELEASE; DISTRIBUTION UNLIMITED

408887

80 1 - 9 336

TABLE OF CONTENTS

	PAGE NUMBER
PREFACE .....	111
SUMMARY OF RESULTS .....	iv
INTRODUCTION .....	1
SURVEY METHODOLOGY .....	1
CAREER LADDER STRUCTURE .....	7
ANALYSIS OF DAFSC GROUPS .....	18
ANALYSIS OF EXPERIENCE (TAFMS) GROUPS .....	25
COMPARISON OF SURVEY DATA TO AFR 39-1 SPECIALTY DESCRIPTIONS .....	32
ANALYSIS OF CONUS VERSUS OVERSEAS GROUPS .....	33
ANALYSIS OF TASK DIFFICULTY .....	35
ANALYSIS OF TRAINING EMPHASIS .....	41
WRITE-IN COMMENTS .....	45
COMPARISON TO PREVIOUS SURVEY .....	46
IMPLICATIONS .....	47
APPENDIX A .....	48

Accession For	
NTIS GRA&I	<input checked="" type="checkbox"/>
DDC TAB	<input type="checkbox"/>
Unannounced	<input type="checkbox"/>
Justification	
By _____	
Distribution/ _____	
Availability Codes	
Dist	Avail and/or special
A	

## PREFACE

This report presents the results of a detailed Air Force Occupational Survey of the Corrosion Control (AFS 427X1) specialty. The report was prepared for HQ ATC/TTQ in response to their request for occupational data on the tasks and jobs performed by 427X1 personnel and the overall morale of the career field. Authority for conducting occupational surveys is contained in AFR 35-2. Computer outputs from which this report was produced are available for use by operating and training officials.

Computer programs for analyzing the occupational data were designed by Dr. Raymond E. Christal, Manpower and Personnel Division, Air Force Human Resources Laboratory (AFHRL), and were written by the Computer Programming Branch, Technical Services Division, AFHRL.

The Air Force occupational survey program has been in existence since 1956 when initial research was undertaken by AFHRL (Air Force Systems Command) to develop a methodology for gathering and analyzing occupational information. In 1967, an occupational survey program was established within the Air Training Command and surveys were produced annually for 12 enlisted specialties. In 1972, the program was expanded to conduct occupational surveys covering 51 career fields annually. In late 1976, the program was again expanded to include the survey of officer utilization fields, to permit special management applications projects, and to support interservice or joint service occupational analysis.

The survey instrument used in the present project was developed by Captain Harry A. Trask, Inventory Development Specialist. Second Lieutenant Gordon J. Curphy analyzed the survey data and wrote the final report. This report has been reviewed and approved by Lieutenant Colonel Jimmy L. Mitchell, Chief, Airman Career Ladders Analysis Section, Occupational Survey Branch, USAF Occupational Measurement Center, Randolph AFB, Texas 78148.

Copies of this report are available to air staff sections, major commands, and other interested training and management personnel upon request to the USAF Occupational Measurement Center, attention to the Chief, Occupational Survey Branch (OMY), Randolph AFB, Texas 78148.

This report has been reviewed and is approved.

BILLY C. McMASTER, Col, USAF  
Commander  
USAF Occupational Measurement  
Center

WALTER E. DRISKILL, Ph.D.  
Chief, Occupational Survey Branch  
USAF Occupational Measurement  
Center

## SUMMARY OF RESULTS

1. Survey Coverage: Inventory booklets were administered to Corrosion Control (AFSC 427X1) personnel from March to July 1979. Survey results are based on the responses from 1,122 AFS 427X1 incumbents (83 percent of assigned). A majority of the incumbents surveyed (78 percent) were assigned to TAC, SAC, MAC, or USAFE.

2. Career Ladder Structure: Five clusters and three independent job types were identified. The five clusters were Experienced Craftsmen, Applications and Removal Personnel, Missile Corrosion Personnel, Aircraft Washer Personnel, and Corrosion Control Supervisors. The three independent job types were Camouflage Applicators, Spray Painters, and Corrosion Removal Personnel.

The Applications and Removal cluster made up 63 percent of the total sample, with respondents involved with removing protective coatings, applying protective coatings, maintaining corrosion control equipment, and performing general corrosion control functions.

3. Career Ladder Progression: Maintenance of corrosion control equipment, applying protective coatings, and corrosion removal tasks were indicative of AFS 42731 personnel. AFS 42751 personnel also performed primarily a technical job involving corrosion removal and applying protective coatings, but also spent a small amount of their job time (nine percent) on supervisory tasks. Seven-skill level incumbents performed primarily technical or administrative tasks, but reported spending a somewhat larger percentage of job time (36 percent) on supervisory tasks.

4. AFMS Groups: The typical trend of increasing percentage of time spent on supervisory tasks with increasing months TAFMS was noted. However, only the sixth enlistment group (241+ months TAFMS) reported spending a majority of their time on supervisory tasks.

5. AFR 39-1 Evaluation: AFR 39-1 provided a clear overview of the 427X1 career ladder. However, the 3-, 5-, and 7-skill level incumbents all reported spending time washing aircraft or AGE, but no mention of these tasks was found in the Specialty Descriptions. Also, 7-skill level incumbents spent 45 percent of their job time on technical tasks, yet the Specialty Description for this skill level was found to not adequately cover these technical tasks.

6. Analysis of CONUS Versus Overseas Groups: Very few differences were noted between these groups. Both CONUS and overseas incumbents reported spending a majority of their time applying protective coatings, removing corrosion and protective coatings, maintaining corrosion control equipment, and performing general corrosion control functions. However, a larger percentage of CONUS respondents reported performing decal related tasks while a larger percentage of overseas respondents reported washing or decontaminating aircraft.

Generally, overseas respondents averaged greater months of TAFMS, greater average paygrade, and performed four less tasks than CONUS respondents.

7. Write-In Comments: Generally the write-in comments reflected that the morale for the 427X1 career ladder was fair. Comments about problem areas in the field include the lack of actual corrosion control performed at some bases, "cosmetic painting," and the possibility of having 541X0G personnel assume Minuteman corrosion control tasks.

8. Implications: The 427X1 career ladder should remain fairly stable in the near future. Lower than normal reenlistment intentions and the possibility of eliminating duplication of training on Minuteman corrosion control should have little if any impact on the career ladder. Also, the allegation of "cosmetic painting" should be investigated to reduce the chances of occupational hazards occurring.

OCCUPATIONAL SURVEY REPORT  
CORROSION CONTROL CAREER LADDER  
(AFSC 427X1)

INTRODUCTION

↘ This is a report of an occupational survey of the Corrosion Control career ladder (AFSC 427X1) completed by the Occupational Survey Branch, USAF Occupational Measurement Center, in October 1979. A previous survey for the 427X1 career ladder was published in March 1975.

Historically, the Corrosion Control career ladder was authorized in March 1965 and was designated as AFSC 535X0. In May 1975, it was redesignated AFSC 531X4 and held this designation until 30 April 1977. Since April 1977, the current AFSC 427X1 designation has been used.

↘ The basic job of these personnel, ~~as described by AFR 39-1~~, is to perform all aspects of corrosion control associated with aircraft, missiles, or AGE. Generally this would involve applying protective coatings, removing corrosion or protective coatings, and servicing corrosion control equipment. Because of the technical nature of corrosion control, all incumbents in this career ladder complete the six week J3ABR42731 corrosion control course taught at Sheppard AFB, Texas. This is a Category "A" training and approximately 350 incumbents per year successfully complete the course.

The current project was requested by HQ ATC/TTQ in order to update occupational data about the tasks and jobs performed by AFS 427X1 personnel. Topics discussed in this report include: (1) survey methodology; (2) job structure within the ladder; (3) an analysis of skill level groups; and (4) a comparison of the results of the current survey with the previous survey.

SURVEY METHODOLOGY

Inventory Development

The data collection instrument for this occupational survey was USAF Job Inventory AFPT 90-427-385. As a starting point, tasks from the 1975 inventory were reviewed for inclusion in a new AFS 427X1 task list. A tentative task list was then formulated which included new tasks obtained from a thorough research of specialty publications and directives. This tentative task list was taken out into the field to be validated by subject matter specialists working in operational units as well as by personnel at the Technical Training school.

APPROVED FOR PUBLIC RELEASE; DISTRIBUTION UNLIMITED

From this review process, a final inventory was developed consisting of 461 tasks grouped under 16 duty headings. Also included in the inventory was a background section about the respondent's grade, duty title, job interest, etc.

### Survey Administration

Job inventories were administered to all DAFSC 427X1 personnel at operational units both in CONUS and overseas during the period March to July 1979 by local consolidated base personnel offices. Personnel were selected from Uniform Airman Record (UAR) data tapes generated by AFMPC and maintained by the Air Force Human Resources Laboratory (AFHRL).

A job inventory consists of two sections. A background and identification section includes questions about such items as job satisfaction, equipment used, or the reenlistment intentions of the survey respondents. A task section lists all tasks which can be performed by career ladder personnel. Incumbents first check the tasks they perform and then rate the relative amount of time spent on each task as compared to all other tasks checked. This relative rating is accomplished using a scale ranging from one (very small amount of time spent) to nine (very large amount of time spent). A rating of five represents an average amount of time spent performing a task on the scale.

To determine the relative amount of time an incumbent spends on each task, all of the incumbent's ratings are assumed to account for 100 percent of his or her time spent on the job. The ratings are then summed and each task rating is then divided by the total number of task responses and the quotient is multiplied by 100. This procedure provides a basis for comparing tasks, not only in terms of percent members performing, but also in terms of average percent time spent.

### Survey Sample

Personnel were selected to participate in this survey so as to insure an accurate representation across all MAJCOM and DAFSC groups. Eighty-three percent (1,122) of the 1,353 incumbents assigned to the DAFSC 427X1 career field were sampled. Table 1 lists the distribution of the sample by MAJCOM, and reveals the sample was an accurate representation of the MAJCOMs. Table 2 lists DAFSC group distributions and Table 3 lists the sample distribution by Total Active Federal Military Service (TAFMS) groups. Both tables reveal the survey had a balanced distribution across DAFSC and TAFMS groups. As can be seen from Table 3, almost 60 percent of the personnel in this specialty were in their first enlistment (1-48 months TAFMS).

TABLE 1

## COMMAND REPRESENTATION OF SAMPLE SURVEY

<u>COMMAND</u>	<u>PERCENT OF ASSIGNED</u>	<u>PERCENT OF SAMPLE</u>
TAC	26	24
SAC	22	24
MAC	20	20
USAFE	11	10
PACAF	7	7
ATC	7	6
AFSC	2	1
OTHER	<u>5</u>	<u>8</u>
TOTAL	100	100
TOTAL ASSIGNED - 1,353		
TOTAL SAMPLED - 1,122		
PERCENT SAMPLED - 83%		

TABLE 2

## SKILL LEVEL REPRESENTATION OF SAMPLE SURVEY

<u>SKILL LEVEL</u>	<u>PERCENT OF ASSIGNED*</u>	<u>PERCENT OF SAMPLE</u>
3	15	14
5	63	64
7	<u>22</u>	<u>22</u>
TOTAL	100	100

\* AS OF OCTOBER 1979

TABLE 3

## TAFMS DISTRIBUTION OF SURVEY SAMPLE

	<u>MONTHS TIME IN SERVICE</u>					
	<u>1-48</u>	<u>49-96</u>	<u>97-144</u>	<u>145-192</u>	<u>193-240</u>	<u>241+</u>
NUMBER IN AFS 427X1 SAMPLE	649	189	151	53	60	14
PERCENT OF AFS 427X1 SAMPLE	58%	17%	14%	5%	5%	1%

### Task Factor Administration

In addition to completing a job inventory booklet, selected senior 427X1 personnel were also asked to complete a second booklet for either training emphasis or task difficulty. The task difficulty and training emphasis rating booklets are processed separately from the job inventories and these ratings may be used in a number of different analyses discussed in more detail within the report.

Task Difficulty. Each individual completing a task difficulty booklet was asked to rate all of the tasks on a nine-point scale from extremely low to extremely high difficulty, with difficulty defined as the length of time it takes an average incumbent to learn to do the task. Ratings were then adjusted so that tasks of average difficulty have a rating of 5.00.

Task difficulty data was independently collected from 52 experienced 7- or 9-skill level personnel stationed worldwide (see Table 4). The interrater reliability (as assessed through components of variance of standardized group means) of .93 for these 427X1 raters is considered useable. The resulting data is a relative ordering of tasks indicating the relative degree of difficulty for each task in the inventory.

After computing the task difficulty index for each item, it is then possible to compute a Job Difficulty Index (JDI) for the job groups identified in the survey analysis. This index provides a relative measure of which jobs, when compared to other jobs identified, are more or less difficult. An equation using the number of tasks performed and the average difficulty per unit time spent as variables are the basis for the JDI. The index ranges from one for very easy jobs to 25 for very difficult jobs. The indices are adjusted so that the average job difficulty index is 13.00. Thus, the more time a group spends on difficult tasks, and the more tasks they perform, the higher will be their job difficulty index. The JDI ratings for the 427X1 career ladder are found in the CAREER LADDER STRUCTURE section.

Training Emphasis. Individuals completing training emphasis booklets were asked to rate all of the tasks on a ten-point scale ranging from no training required to extremely heavy training. Training emphasis is a rating of tasks indicating where emphasis should be placed on structured training for first-term personnel. Structured training is defined as training provided at resident technical schools, Field Training Detachments (FTD), Mobile Training Teams (MTT), Formal OJT, or any other organized training method.

Training emphasis data was independently collected from 50 experienced 7- or 9- skill level personnel stationed worldwide (see Table 5). The interrater reliability (as assessed through components of variance of standard group means) for these raters was high (.96), indicating

there was good agreement among raters as to which tasks required some form of structured training and which did not. In this specialty, tasks rated highest in training emphasis have ratings of 4.6 or above; the average training emphasis rating is 2.7; and those tasks with ratings of less than 1.0 can be considered as requiring very little emphasis in training.

When used in conjunction with other factors, such as percent members performing, the task difficulty and training emphasis ratings can provide an insight into the appropriate method of training. This may help validate the lengthening or shortening of specific units of instruction in various training programs.

TABLE 4

## COMMAND REPRESENTATION OF 427X1 TASK DIFFICULTY RATERS

<u>COMMAND</u>	<u>PERCENT ASSIGNED</u>	<u>PERCENT SAMPLED</u>
TAC	26	26
SAC	22	40
MAC	20	7
USAFE	11	5
PACAF	7	14
ATC	7	5
AFSC	2	*
OTHER	<u>5</u>	<u>3</u>
TOTAL	100	100

\* DENOTES LESS THAN ONE PERCENT

TABLE 5

## COMMAND REPRESENTATION OF 427X1 TRAINING EMPHASIS RATERS

<u>COMMAND</u>	<u>PERCENT ASSIGNED</u>	<u>PERCENT SAMPLED</u>
TAC	26	16
SAC	22	28
MAC	20	24
USAFE	11	14
PACAF	7	4
ATC	7	6
AFSC	2	1
OTHER	<u>5</u>	<u>7</u>
TOTAL	100	100

## CAREER LADDER STRUCTURE

A key aspect of the occupational survey program is to examine the job structure of the career ladder on the basis of what people are actually doing in the field, rather than on the basis of how official career ladder documents say they are structured. This analysis of actual job structure is made possible by the use of the Comprehensive Occupational Data Analysis Programs (CODAP). By using CODAP, job functions are identified on the basis of similarity in tasks performed and relative time spent performing the tasks.

The specialty structure analysis process consists of determining the functional job structure of career field personnel in terms of job types, clusters, and independent job types. A job type is a group of individuals who perform many of the same tasks and also spend similar amounts of time performing them. When there is a substantial degree of similarity between different job types, they are grouped together and labeled as clusters. Finally, there are often cases of specialized job types that are too dissimilar to be grouped into any cluster. These unique groups are labeled independent job types.

### Specialty Structure Overview

The corrosion control career ladder was found to be fairly homogeneous. In other words, a large majority of the personnel in the career ladder reported performing a common core of tasks. Table 6 reveals a representative list of those tasks which at least 70 percent of the 427X1 sample performed. This common core of tasks involves primarily corrosion removal and applying protective coatings, such as preparing primers for application, applying enamels to surfaces using spray methods and removing corrosion using hand wire brushes. All of the job types, clusters, and independent job types reported performing these tasks to some extent; the varying amount of time spent on these tasks or the emphasis in other aspects of corrosion control differentiated the clusters and independent job types.

The job structure of the corrosion control specialty consists of five clusters and three independent job types. Based on task similarity and the amount of time spent performing each task, the jobs performed by the 427X1 respondents are listed below and illustrated in Figure 1. (GRP numbers are shown with each group as a cross reference to computer printed summaries used in the analysis of the survey data.)

FIGURE 1

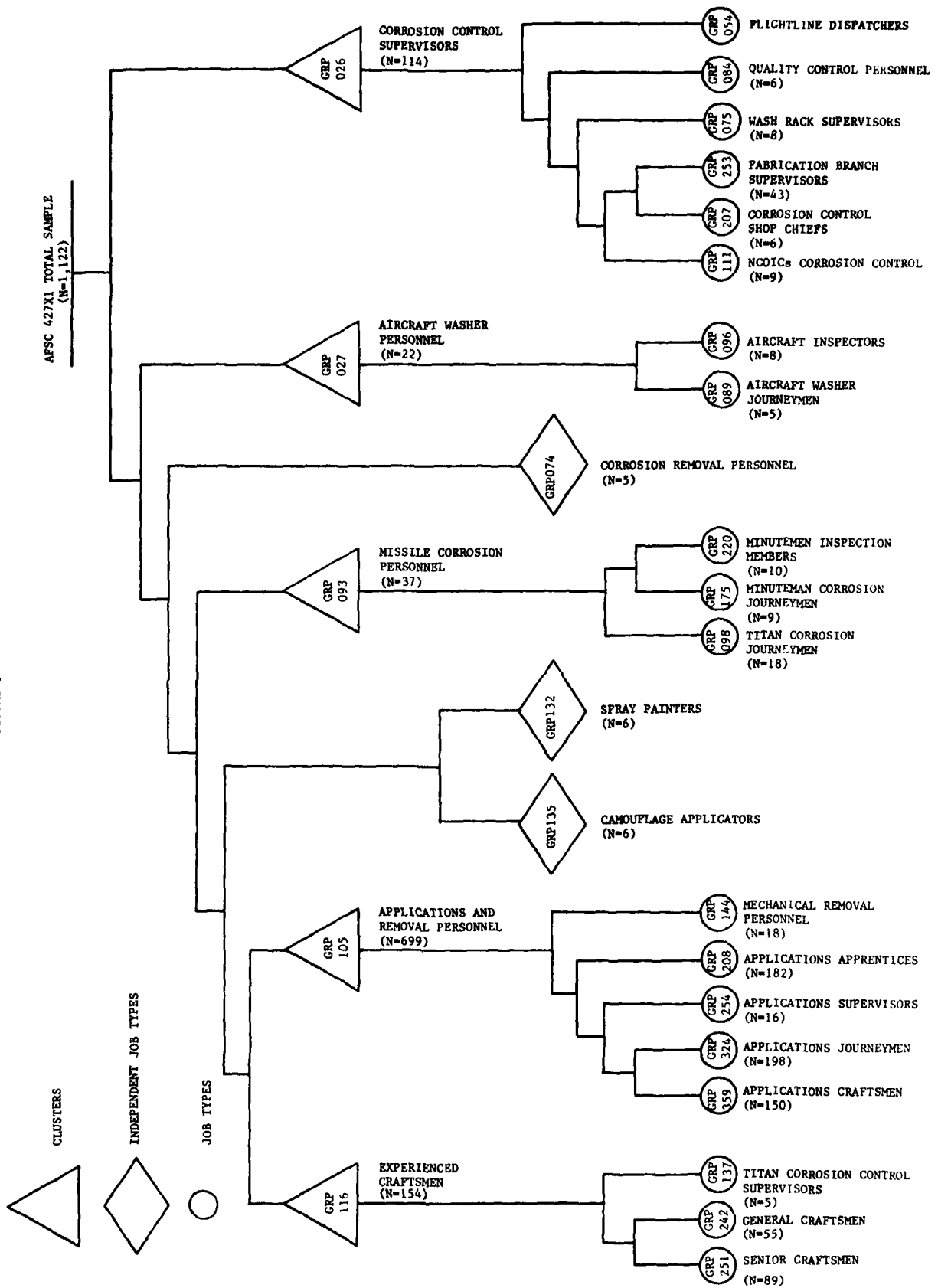

- I. EXPERIENCED CRAFTSMEN (GRP116, N=154)
  - a. Senior Craftsmen (GRP251, N=89)
  - b. General Craftsmen (GRP242, N=55)
  - c. Titan Corrosion Control Supervisors (GRP137, N=5)
- II. APPLICATIONS AND REMOVAL PERSONNEL (GRP105, N=699)
  - a. Applications Craftsmen (GRP359, N=150)
  - b. Applications Journeymen (GRP324, N=198)
  - c. Applications Supervisors (GRP254, N=16)
  - d. Applications Apprentices (GRP208, N=182)
  - e. Mechanical Removal Personnel (GRP144, N=18)
- III. CAMOUFLAGE APPLICATORS (GRP135, N=6)
- IV. SPRAY PAINTERS (GRP132, N=6)
- V. MISSILE CORROSION PERSONNEL (GRP093, N=37)
  - a. Titan Corrosion Journeymen (GRP098, N=18)
  - b. Minuteman Corrosion Journeymen (GRP175, N=9)
  - c. Minuteman Inspection Members (GRP220, N=10)
- VI. CORROSION REMOVAL PERSONNEL (GRP074, N=5)
- VII. AIRCRAFT WASHER PERSONNEL (GRP027, N=22)
  - a. Aircraft Washer Journeymen (GRP089, N=5)
  - b. Aircraft Inspectors (GRP096, N=8)
- VIII. CORROSION CONTROL SUPERVISORS (GRP026, N=114)
  - a. NCOICs Corrosion Control (GRP111, N=9)
  - b. Corrosion Control Shop Chiefs (GRP207, N=6)
  - c. Fabrication Branch Supervisors (GRP253, N=43)
  - d. Wash Rack Supervisors (GRP075, N=8)
  - e. Quality Control Personnel (GRP084, N=6)
  - f. Flightline Dispatchers (GRP054, N=8)

Ninety-three percent of the respondents in the sample perform jobs that are identified in this analysis. The remaining seven percent of the sample consists of individuals whose jobs were not similar to the groups outlined above. Examples of the job titles of the remaining seven percent include 15 NCOICs of various aspects of corrosion control, three Quality Control Inspectors, 21 Corrosion Control Specialists, and one Dorm Manager. While some of these titles appear similar to the clusters and job types listed above, these individuals perform unique jobs and did not group with the more distinct job types.

TABLE 6

SOME COMMON CORE TASKS PERFORMED BY 427X1 PERSONNEL  
(PERCENT MEMBERS PERFORMING)

TASKS	DAFSC 427X1 (N=1,122)
APPLY MASKING MATERIALS TO SURFACES	89
CLEAN WORK AREAS	88
APPLY PRIMERS TO SURFACES USING SPRAY METHODS	86
PAINT OR STENCIL SIGNS	86
REMOVE MASKING MATERIALS FROM SURFACES	85
APPLY POLYURETHANE COATINGS TO SURFACES USING SPRAY METHODS	83
PREPARE PRIMERS FOR APPLICATION	82
APPLY IACQUERS TO SURFACES USING SPRAY METHODS	82
APPLY ENAMELS TO SURFACES USING SPRAY METHODS	81
PREPARE POLYURETHANE COATINGS FOR APPLICATION	81
WIPE DOWN SURFACES WITH THINNERS PRIOR TO PAINTING	81
SET UP OR TEAR DOWN CONVENTIONAL SPRAY EQUIPMENT	80
REMOVE PROTECTIVE COATINGS USING PAINT REMOVERS	80
REMOVE CORROSION USING HAND WIRE BRUSHES	77
REMOVE PROTECTIVE COATINGS USING PNEUMATIC SANDERS	73

## Group Descriptions

Brief descriptions of the major job groups which encompass the important functions of the Corrosion Control specialty are given below. The relative percent time spent on each duty by each of the clusters and independent job types is shown in Table 7, with selected background information for each of these groups listed in Table 8. Table 9 reveals the perceptions of each of these groups in terms of how interesting they find their job, the degree to which they perceive their talents and training are being utilized, and whether or not they plan to reenlist. Discussions within this section relating to the difficulty of a particular job group refer to an index which reflects the relative difficulty of one job as compared to other jobs identified in the analysis. A detailed discussion of the job difficulty index can be found in the Task Factor Administration section in this report.

I. EXPERIENCED CRAFTSMEN (GRP116). Approximately half of these 154 respondents held DAFSC 42771, the remainder possessing DAFSC 42751. These respondents performed an average of 237 tasks, and had a Job Difficulty Index (JDI) of 20.5, both of which were the highest found for all of the clusters and independent job types. Generally, these incumbents were differentiated by the wide variety and the large number of corrosion control tasks they performed, since incumbents were responsible for performing virtually all aspects of corrosion control. Table 7 reveals these incumbents, with the exception of the missile corrosion duties, spend roughly an equal amount of time on the supervision, administrative, corrosion removal, and applying protective coatings duties. Typical tasks for these incumbents include: preparing AFTO Forms 349, preparing primers for application, and directing corrosion shop equipment. Table 9 reveals 79 percent of these incumbents perceived their training was being utilized at least fairly well, and 58 percent planned to reenlist. There were three job types identified in this cluster, and include: (1) Senior Craftsmen; (2) General Craftsmen; and (3) Titan Corrosion Control Supervisors. These job types were differentiated by the supervisory, technical, and missile tasks they performed. (Tables I, II, and III in Appendix A provide various background and duty information about each of these job types).

II. APPLICATIONS AND REMOVAL PERSONNEL (GRP105). This cluster of 699 respondents was the largest group found in the analysis. Table 8 reveals 91 percent of these incumbents held DAFSC 42731 or 42751, and the remainder were 7-skill level incumbents. These incumbents seem to be the people on the flightline or shop who perform primarily aircraft corrosion control. Table 9 reveals these incumbents spend 79 percent of their job time on four duties, these being performing general corrosion control functions; removing corrosion; applying protective coatings; and maintaining corrosion control equipment. Common tasks include removing protective coatings using paint removers, painting or stenciling signs, disposing of protective coatings materials, and cleaning or oiling pneumatic powered tools. Five job

types were identified in the cluster, these being Applications Craftsmen, Applications Journeymen, Applications Supervisors, Applications Apprentices, and Mechanical Removal Personnel. Generally, the tasks performed by members of all of these job types were the same; only the number of tasks or supervisory or removal tasks performed differentiated these job types (see Tables IV, V and VI in Appendix A).

III. CAMOUFLAGE APPLICATORS (GRP135). Table 8 reveals five of these six incumbents held DAFSC 42751, with the other individuals holding DAFSC 42731. Only 33 percent of these incumbents plan to reenlist, while 67 percent felt their training was being utilized at least fairly well. Table 7 reveals these respondents are fairly similar to the previous cluster, spending a majority of their job time on aircraft corrosion control duties. Common tasks for these incumbents include applying primers to surfaces using spray methods and applying camouflage coatings to aircraft or AGE. The low number of tasks performed by these incumbents (42 versus 95 for Applications and Removal Personnel) is probably a key differentiating factor for this group.

IV. SPRAY PAINTERS (GRP132). These six respondents primarily performed a job involving the application of protective coatings using spray guns. Table 7 reveals these respondents spend almost 50 percent of their job time on the applications of protective coatings. Common tasks for these incumbents were setting up and tearing down conventional spray equipment, applying polyurethane coatings or lacquers to aircraft, and painting or stenciling signs. Table 8 reveals all of these respondents hold DAFSC 42731 or 42751, and 83 percent were in their first enlistment. Table 9 shows 83 percent of these incumbents do not plan to reenlist.

V. MISSILE CORROSION PERSONNEL (GRP093). These 37 respondents were all assigned to SAC, and seemed to be responsible for the corrosion control of the Titan and Minuteman missile systems. Table 7 reveals these incumbents spend 25 percent of their job time on missile related duties such as Titan or Minuteman corrosion control. Common tasks include coordinating with missile crew members on maintenance to be performed, inspecting Minuteman launcher level 1 for corrosion, and inspecting Titan solo level 4 facilities for corrosion. Table 8 reveals these incumbents performed an average of 91 tasks and had an average paygrade of 3.5. Table 9 reveals 51 percent of these respondents plan to reenlist but only 38 percent perceive their job as interesting. Within this cluster were the three job types of Titan Corrosion Journeyman, Minuteman Corrosion Journeymen, and Minuteman Inspection Members. The incumbents of these job types were differentiated by either the missile system they were responsible for, or the amount of time spent evaluating protective coatings or corrosion damage. (See Tables VII, VIII, and IX in Appendix A for more information about these job types.)

VI. CORROSION REMOVAL PERSONNEL (GRP074). These five incumbents were all assigned to MAC, and seemed to be responsible for various corrosion control tasks associated with MAC aircraft. Table 7 reveals these incumbents spend 32 percent of their job time removing protective coatings or corrosion, which was the highest percentage for all clusters and independent job types. Common tasks include applying walkway coatings, painting or stenciling signs, and removing protective coatings using solvents or thinners. Table 8 reveals all of these incumbents were in their first enlistment and performed an average of 39 tasks. Table 9 reveals 40 percent of these respondents plan to reenlist and 40 percent perceive their job as interesting.

VII. AIRCRAFT WASHER PERSONNEL (GRP027). These 22 respondents were responsible for washing or decontaminating various aircraft. Table 7 reveals these incumbents spend 29 percent of their time on washing tasks, such as setting up aircraft washing equipment, inspecting aircraft for cleanliness prior to refurbishment, and preparing aircraft cleaning solutions prior to application. Table 8 reveals that 14 percent of these incumbents hold DAFSC 42731, 64 percent were 5-skill level personnel, and the remainder possessed DAFSC 42771. Table 9 reveals only 18 percent plan to reenlist. Aircraft Washer Journeymen and Aircraft Washer Inspectors were the job types identified in this cluster. These incumbents were differentiated on the percentage of time spent performing general corrosion control functions and evaluating aircraft cleanliness. (For further information about these job types see Tables X, XI, and XII in Appendix A.)

VIII. CORROSION CONTROL SUPERVISORS (GRP026). These 114 respondents seem to be the supervisors of the various activities associated with corrosion control. Table 7 reveals these incumbents spend 48 percent of their job time on supervisory tasks, such as supervising Corrosion Control Specialists (DAFSC 42751), planning or scheduling work assignments, and preparing APRs. Table 8 reveals this heterogeneous cluster of 114 incumbents had the second highest JDI (16.4) and averaged supervising 4.8 personnel. Only 20 percent were 5-skill level respondents, with the remainder holding the 7-skill level. Table 9 reveals 80 percent of these incumbents perceived they utilized their training at least fairly well, and 70 percent planned to reenlist. This cluster was fairly heterogeneous, and six distinct job types were found. These job types include: NCOICs Corrosion Control; Corrosion Control Shop Chiefs; Fabrication Branch Supervisors; Wash Rack Supervisors; Quality Control Personnel; and Flightline Dispatchers. Generally, the amount of time spent on supervision and the type of technical tasks performed, such as directing aircraft washing, separated the job types. (For further information about these job types refer to Tables XIII, XIV, and XV in Appendix A.)

### Structure Summary

Overall, the Corrosion Control specialty was found to be fairly homogeneous, with a common core of tasks performed, to some extent, by the total sample. This core of tasks seems to involve various aspects of the application of protective coatings or corrosion removal, such as applying primers to surfaces using spray methods and removing protective coatings using hand wire brushes.

Five main clusters and three independent job types were identified in the 427X1 specialty. Generally, all of the incumbents in these clusters performed a common core tasks; differentiating factors were the number of tasks performed, the percentage of time spent on the core tasks, the type of equipment worked upon (AGE, aircraft, or missiles), or the percentage of time spent on other aspects of the job, such as administrative and supervisory tasks.

The independent job types were Camouflage Applications, Spray Painters, and Corrosion Removal Personnel. Generally, these incumbents perform fewer tasks, have lower reenlistment intentions, and tend to perform tasks which focus on only one or two aspects of corrosion control, such as applying protective coatings using spray methods, or applying camouflage to AGE. However, most of these incumbents perform a majority of the common core of tasks, indicating the career field is fairly homogeneous.

TABLE 7

RELATIVE PERCENT TIME SPENT ON DUTIES BY JOB CLUSTERS AND INDEPENDENT JOB TYPES

DUTIES	EXPERIENCED CRAFTSMEN (N=154)		APPLICATIONS AND REMOVAL PERSONNEL (N=699)		CAMOUFLAGE APPLICATORS (N=6)		SPRAY PAINTERS (N=6)		MISSILE CORROSION PERSONNEL (N=37)		CORROSION REMOVAL PERSONNEL (N=5)		AIRCRAFT WASHER PERSONNEL (N=22)		CORROSION CONTROL SUPERVISORS (N=114)	
	GRP116	GRP105	GRP135	GRP132	GRP093	GRP074	GRP027	GRP026								
ORGANIZING AND PLANNING	6	2	2	1	1	3	5	15								
DIRECTING AND IMPLEMENTING	5	2	*	2	2	3	7	13								
INSPECTING AND EVALUATING	5	2	*	*	*	2	4	12								
TRAINING	4	*	*	*	1	1	*	8								
WORKING WITH FORMS, RECORDS, REPORTS, DIRECTIVES AND TECHNICAL DATA	10	4	*	2	3	3	6	22								
PERFORMING GENERAL CORROSION CONTROL FUNCTIONS	12	20	28	21	21	35	24	6								
WASHING AIRCRAFT AND AEROSPACE GROUND EQUIPMENT (AGE)	6	5	*	3	*	2	29	3								
INSPECTING AIRCRAFT, AEROSPACE GROUND EQUIPMENT (AGE) AND MISSILES	4	4	7	*	5	6	3	5								
REMOVING CORROSION AND PROTECTIVE COATINGS	14	16	17	13	17	32	6	*								
TREATING AND PREPARING METAL SURFACES	3	2	1	1	3	3	2	4								
APPLYING PROTECTIVE COATING SYSTEMS	19	32	34	49	15	7	6	*								
PERFORMING AND PRACTICING DISASTER PREPAREDNESS FUNCTIONS	*	*	*	*	*	3	1	*								
MAINTAINING CORROSION CONTROL EQUIPMENT	10	11	6	5	6	*	4	4								
PERFORMING MISSILE DISPATCH FUNCTIONS	*	*	*	*	6	*	*	*								
PERFORMING MINUTEMAN CORROSION CONTROL FUNCTIONS	*	*	*	*	9	*	*	*								
PERFORMING TITAN MISSILE CORROSION CONTROL FUNCTIONS	*	*	*	*	10	*	*	*								

\* DEMOTES LESS THAN ONE PERCENT

TABLE 8  
BACKGROUND INFORMATION BY CLUSTERS AND INDEPENDENT JOB TYPES

	EXPERIENCED CRAFTSMEN	APPLICATIONS AND REMOVAL PERSONNEL		CAMOUFLAGE APPLICATORS	SPRAY PAINTERS	MISSILE CORROSION PERSONNEL	CORROSION REMOVAL PERSONNEL	AIRCRAFT WASHER PERSONNEL	CORROSION CONTROL SUPERVISORS
		95	42						
AVERAGE NUMBER OF TASKS PERFORMED	237	95	42	43	91	39	41	103	
AVERAGE PAY GRADE	4.7	3.5	3.3	3.0	3.5	3.2	4.0	5.8	
AVERAGE NUMBER OF PERSONNEL SUPERVISED	3.6	.5	0	0	.3	0	1.2	4.8	
JOB DIFFICULTY INDEX (JDI)	20.5	11.7	7.1	7.6	11.8	7.6	7.5	16.4	
DAFSC:									
42731	7%	16%	17%	33%	16%	40%	14%	0%	
42751	48%	75%	83%	67%	81%	60%	64%	20%	
42771	45%	9%	0%	0%	3%	0%	22%	80%	
AVERAGE MONTHS IN CAREER LADDER									
AVERAGE MONTHS TAFTS	83	40	44	26	42	28	58	119	
PERCENT IN FIRST ENLISTMENT	96	44	45	28	46	30	70	158	
	28%	72%	83%	83%	70%	100%	41%	5%	

TABLE 9

JOB INTEREST AND RELATED DATA BY CLUSTERS AND INDEPENDENT JOB TYPES  
(PERCENT RESPONDING)

	EXPERIENCED CRAFTSMEN	APPLICATIONS AND REMOVAL PERSONNEL		CAMOUFLAGE APPLICATORS	SPRAY PAINTERS	MISSILE CORROSION PERSONNEL		CORROSION REMOVAL PERSONNEL		AIRCRAFT WASHER PERSONNEL		CORROSION CONTROL SUPERVISORS	
		PERSONNEL	PERSONNEL			PERSONNEL	PERSONNEL	PERSONNEL	PERSONNEL	PERSONNEL	PERSONNEL		
<u>I FIND MY JOB:</u>													
NO RESPONSE	5	2	0	0	0	0	0	20	0	0	0	3	
DULL	18	27	33	83	11	18	11	0	18	11	17	17	
SO-SO	20	35	17	17	32	64	17	40	64	17	17	17	
INTERESTING	57	36	50	50	0	18	38	40	18	69	69	69	
<u>MY JOB UTILIZES MY TALENTS:</u>													
NO RESPONSE	0	1	0	0	0	0	3	0	0	0	0	2	
NOT AT ALL TO VERY LITTLE	18	38	33	57	43	50	49	60	50	21	21	21	
FAIRLY WELL TO VERY WELL	70	57	67	43	48	50	48	40	50	68	68	68	
EXCELLENTLY TO PERFECTLY	12	4	0	0	0	0	0	0	0	9	9	9	
<u>MY JOB UTILIZES MY TRAINING:</u>													
NO RESPONSE	3	1	0	0	0	0	0	0	0	0	0	0	
NOT AT ALL TO VERY LITTLE	18	34	33	33	33	40	43	40	40	55	55	20	
FAIRLY WELL TO VERY WELL	64	61	67	50	54	60	54	60	60	45	66	66	
EXCELLENTLY TO PERFECTLY	15	4	0	17	3	0	3	0	0	0	14	14	
<u>I PLAN TO REENLIST:</u>													
NO RESPONSE	3	2	0	0	0	0	0	0	0	0	0	4	
NO	23	36	67	50	33	50	22	60	50	18	18	18	
PROBABLY NO	16	22	0	33	27	0	27	0	9	9	9	9	
PROBABLY YES	19	21	17	17	22	17	22	40	22	17	17	17	
YES	39	19	16	16	0	29	29	0	16	53	53	53	

## ANALYSIS OF DAFSC GROUPS

An analysis of DAFSC groups forms a part of each occupational analysis. The DAFSC analysis helps to identify differences among skill level groups within the 427X1 specialty. It also aids in the analysis of career ladder documents, such as AFR 39-1 Specialty Descriptions and the Specialty Training Standard (STS).

The DAFSC analysis of the 427X1 career field will discuss the duties and tasks common to the DAFSC groups, as well as discussing the tasks which best differentiate the 3-, 5-, and 7-skill level incumbents.

### DAFSC 427X1 Skill Level Comparisons

Table 10 reveals 42731 incumbents spend 35 percent of their job time applying protective coatings systems, with the remainder being spent performing corrosion removal, general corrosion control functions, and maintaining corrosion control equipment. Table 11 lists the tasks performed by the largest percentages of 42731 personnel. These tasks are primarily technical in nature and involve some aspect of corrosion control, such as preparing primers for application and applying enamels to surfaces using spray methods.

Table 12 reflects a listing of those tasks common to 42751 personnel. Like the 3-skill level incumbents, these are generally technical corrosion control tasks, such as wiping down surfaces with thinners prior to painting and applying masking materials to surfaces. Table 10 reveals these incumbents spend nine percent of their job time performing supervisory duties, with the remainder being spent performing technical duties involving general corrosion control functions, and applying or removing protective coatings.

In the comparison of 42731 and 42751 incumbents, Table 10 reveals the greatest duty differences between the two skill level groups occur in the supervision duties. The 42751 incumbents spent nine percent of their job time on supervisory duties, while 3-skill level respondents spent less than one percent of their job time on each of these duties. Table 13 lists those tasks which best distinguish the two skill level groups. Technical tasks, such as rinsing passivated metals and removing protective coatings using metallic wools are performed by larger percentages of 42731 personnel, while supervisory tasks, such as clearing red diagonal conditions or planning work assignments are performed by larger percentages of 5-skill level incumbents.

An examination of the duties performed by 42771 personnel reveals these incumbents spend 36 percent of their job time on supervisory duties, with the 64 percent spent on administrative or technical corrosion control duties, such as applying and removing protective coatings. However, Table 14 indicates supervisory tasks, such as

preparing APRs or counselling personnel on military related matters, are performed by the greatest percentage of 7-skill level incumbents. The data indicates these incumbents are probably the first-line supervisors for the career field.

Differences in both the duties and tasks performed by 5- and 7-skill level incumbents were noted. As stated previously, 42751 incumbents spend only nine percent of their job time on supervisory duties, while Table 10 also reveals 7-skill level incumbents spend 36 percent of their job time on the same duties. The technical duties involving general control functions and applying protective coatings, also separated the two groups. Five-skill level respondents spent 20 and 28 percent of their job time on these two duties while 7-skill level personnel only spent nine and 12 percent of their job time on these same duties.

Table 15 lists the tasks which best distinguish the 5- and 7-skill level groups. Supervisory tasks, such as assigning personnel to duty positions and scheduling leaves or passes seems to be more indicative of 7-skill level incumbents. A larger percentage of 42751 personnel perform technical tasks, such as applying and removing masking materials from surfaces than do 7-skill level incumbents.

#### Summary

In the analysis of skill level groups, maintenance and corrosion control tasks were indicative of 42731 personnel. 42751 personnel performed primarily maintenance and corrosion control tasks, but also spent nine percent of their job time performing supervisory tasks. Seven-skill level incumbents spent much less time on corrosion control and maintenance tasks, and much more time (36 percent) on supervisory tasks.

TABLE 10  
PERCENT TIME SPENT ON DUTIES BY DAFSC GROUPS

DUTIES	DAFSC 42731 (N=142)	DAFSC 42751 (N=722)	DAFSC 42771 (N=246)
A ORGANIZING AND PLANNING	*	3	11
B DIRECTING AND IMPLEMENTING	*	3	10
C INSPECTING AND EVALUATING	*	2	9
D TRAINING	*	1	6
E WORKING WITH FORMS, RECORDS, REPORTS, DIRECTIVES AND TECHNICAL DATA	2	5	16
F PERFORMING GENERAL CORROSION CONTROL FUNCTIONS	23	20	9
G INSPECTING AIRCRAFT, AEROSPACE GROUND EQUIPMENT (AGE), AND MISSILES	4	4	4
H WASHING AIRCRAFT AND AEROSPACE GROUND EQUIPMENT (AGE)	5	5	4
I REMOVE CORROSION AND PROTECTIVE COATINGS	18	15	8
J TREATING AND PREPARING METAL SURFACES	2	2	1
K APPLYING PROTECTIVE COATING SYSTEMS	35	28	12
L PERFORMING AND PRACTICING DISASTER PREPAREDNESS FUNCTIONS	*	*	*
M MAINTAINING CORROSION CONTROL EQUIPMENT	9	10	6
N PERFORMING MISSILE DISPATCH FUNCTIONS	*	*	*
O PERFORMING MINUTEMAN CORROSION CONTROL FUNCTIONS	*	*	*
P PERFORMING TITAN MISSILE CORROSION CONTROL FUNCTIONS	*	*	*

\* DENOTES LESS THAN ONE PERCENT

TABLE 11

## TASKS PERFORMED BY THE GREATEST PERCENTAGES OF 42731 RESPONDENTS

TASKS	PERCENT OF 3-SKILL LEVEL MEMBERS PERFORMING (N=142)
APPLY MASKING MATERIALS TO SURFACES	94
CLEAN WORK AREAS	92
REMOVE MASKING MATERIALS FROM SURFACES	91
APPLY PRIMERS TO SURFACES USING SPRAY METHODS	90
PAINT OR STENCIL SIGNS	89
APPLY POLYURETHANE COATINGS TO SURFACES USING SPRAY METHODS	87
APPLY LACQUERS TO SURFACES USING SPRAY METHODS	86
PREPARE PRIMERS FOR APPLICATION	86
PREPARE POLYURETHANE COATINGS FOR APPLICATION	85
ASSEMBLE CORROSION CONTROL MATERIALS PRIOR TO JOB PERFORMANCE	83
PERFORM DETAILS	83
PREPARE LACQUERS FOR APPLICATION	83
APPLY ENAMELS TO SURFACES USING SPRAY METHODS	82
SET UP OR TEAR DOWN CONVENTIONAL SPRAY EQUIPMENT	82
APPLY EPOXY COATINGS TO SURFACES USING SPRAY METHODS	82

TABLE 12

## TASKS PERFORMED BY THE GREATEST PERCENTAGES OF 42751 RESPONDENTS

TASKS	PERCENT OF 5-SKILL LEVEL MEMBERS PERFORMING (N=722)
CLEAN WORK AREAS	93
APPLY MASKING MATERIALS TO SURFACES	92
PAINT OR STENCIL SIGNS	90
APPLY PRIMERS TO SURFACES USING SPRAY METHODS	89
REMOVE MASKING MATERIALS FROM SURFACES	88
APPLY ENAMELS TO SURFACES USING SPRAY METHODS	85
APPLY POLYURETHANE COATINGS TO SURFACES USING SPRAY METHODS	84
PREPARE PRIMERS FOR APPLICATION	84
APPLY LACQUERS TO SURFACES USING SPRAY METHODS	84
PERFORM DETAILS	84
WIPE DOWN SURFACES WITH THINNERS PRIOR TO PAINTING	84
REMOVE PROTECTIVE COATINGS USING PAINT REMOVERS	83
PREPARE ENAMELS FOR APPLICATION	83
ASSEMBLE CORROSION CONTROL MATERIALS PRIOR TO JOB PERFORMANCE	82

TABLE 13

TASKS WHICH BEST DISTINGUISH DAFSC 42731 AND DAFSC 42751 PERSONNEL  
(PERCENT MEMBERS PERFORMING)

TASKS	DAFSC 42731	DAFSC 42751	DIFFERENCE
REMOVE PROTECTIVE COATINGS USING METALLIC WOOLS	34	26	+8
PREPARE STRIPPABLE COATING COMPOUNDS FOR APPLICATION	43	36	+7
PLACE PASSIVATING SOLUTIONS IN STORAGE	41	34	+7
DISPOSE OF CORROSION REMOVING COMPOUNDS	68	62	+6
RINSE PASSIVATED METALS	26	20	+6
APPLY ELASTOMERIC COATINGS USING SPRAY METHODS	41	36	+5
REMOVE PROTECTIVE COATINGS USING SCRAPERS	70	65	+5
SUPERVISE APPRENTICE CORROSION CONTROL SPECIALISTS (AFSC 42731)	11	38	-27
CLEAR RED DIAGONAL CONDITIONS	36	61	-25
MAKE ENTRIES ON MAINTENANCE DISCREPANCY AND WORK DOCUMENT FORMS (AFTO FORM 781A)	12	36	-24
DRIVE GOVERNMENT VEHICLES	20	44	-24
COORDINATE WITH DOCK CHIEFS OR CREW CHIEFS ON MAINTENANCE ACTIVITIES	18	41	-23
PLAN OR SCHEDULE WORK ASSIGNMENTS	2	24	-22
COORDINATE WITH PRODUCTION SCHEDULING ON IN-SHOP WORK PROGRESS	12	33	-21
FILE MAINTENANCE DATA COLLECTION RECORD FORMS (AFTO FORM 349)	23	42	-19

TABLE 14

## TASKS PERFORMED BY THE GREATEST PERCENTAGES OF 42771 RESPONDENTS

TASKS	PERCENT OF 7-SKILL LEVEL MEMBERS PERFORMING (N=246)
PREPARE APRs	84
SUPERVISE CORROSION CONTROL SPECIALISTS (AFSC 42751)	83
PREPARE AFTO FORMS 349	79
COORDINATE WITH MAINTENANCE OR JOB CONTROL ON FLIGHTLINE DISPATCH WORK	76
COUNSEL PERSONNEL ON PERSONAL OR MILITARY RELATED PROBLEMS	75
REVIEW AFTO FORMS 349	74
PLAN OR SCHEDULE WORK ASSIGNMENTS	74
IDENTIFY TYPES OF CORROSION	72
ASSIGN PERSONNEL TO DUTY POSITIONS	71
DIRECT UTILIZATION OF CORROSION SHOP EQUIPMENT	70
INSPECT AREAS FOR CORROSION USING HAND EQUIPMENT, SUCH AS FLASHLIGHTS, PROBES, OR MIRRORS	69
COORDINATE WITH DOCK CHIEFS OR CREW CHIEFS ON MAINTENANCE ACTIVITIES	68
INSPECT CONDITION OF PROTECTIVE COATINGS	65
CLEAR RED X CONDITIONS	65
FILE MAINTENANCE DATA COLLECTION RECORD FORMS (AFTO FORM 349)	65

## ANALYSIS OF EXPERIENCE (TAFMS) GROUPS

Survey respondents were also analyzed on the basis of months TAFMS. As expected, no major deviations from the usual pattern of increasing time spent on supervisory tasks with increasing months TAFMS were noted. As expected, more junior airmen spent a greater percentage of their time on technical duties, such as applying protective coatings and maintaining corrosion control equipment, while more senior incumbents spent less time performing these duties (see Table 16).

Senior incumbents typically spent more time on supervisory tasks, such as counselling personnel on personal or military related problems, or conducting staff meetings. However, not until the sixth enlistment (241+ months TAFMS) do supervisory tasks make up a majority of their job time. Incumbents in the third through fifth enlistment groups (97-240 months TAFMS) reported spending at least 39 percent of their job time performing technical duties involving various aspects of corrosion control. The senior incumbents in this career field seem to be working supervisors, i.e., perform both technical and supervisory tasks.

### First Enlistment Personnel

First enlistment personnel (1-48 months TAFMS) were also examined on the basis of most common tasks performed and equipment and materials utilized. Table 17 lists the tasks most common to the 427X1 first-term incumbents. These tasks seem to primarily involve the preparation and application of various types of corrosion control coatings, such as preparing lacquers for application and applying polyurethane coatings to surfaces using spray methods. The most common pieces of equipment utilized by the 427X1 first enlistment respondents, such as aerosol paint cans and conventional spray guns, are listed in Table 18. Table 19 reveals that thinners, primers, and enamels are the most common materials used by first job corrosion control personnel. Overall, tasks, equipment, and materials used by these incumbents reflect a majority of job time spent on applying protective coatings or removing corrosion.

### Job Satisfaction Data

Job interest, perceived utilization of talents and training, and reenlistment intentions for 427X1 first-term respondents are presented in Table 20, along with comparative sample of first enlistment personnel from all mission equipment maintenance career ladders surveyed in 1978 (these sample career ladders included ones in the following fields: 30XXX, 31XXX, 32XXX, 34XXX, 36XXX, 40XXX, 42XXX, 43XXX, 44XXX, and 46XXX). When compared with the mission equipment maintenance sample group, a much lower percentage of 427X1 first-term

respondents find their job as interesting (35 percent) as the 1978 sample. A slightly lower percentage of these first-term respondents reported utilizing their talents (60 percent) and training (64 percent) at least fairly well. Finally, the 29 percent of the 427X1 first-term respondents that planned to reenlist was also a slightly lower percentage than the comparative sample reported.

Overall, 427X1 first-term respondents perceive their job as much less interesting, do not utilize their talents and training quite as well, and a smaller percentage planned to reenlist than the 1978 comparative sample.

TABLE 15

TASKS WHICH BEST DISTINGUISH DAFSC 42751 AND DAFSC 42771 PERSONNEL  
(PERCENT MEMBERS PERFORMING)

TASKS	DAFSC 42751	DAFSC 42771	DIFFERENCE
PERFORM DETAILS	84	51	+33
APPLY ENAMELS TO SURFACES USING SPRAY METHODS	85	53	+32
CLEAN WORK AREAS	93	62	+31
REMOVE PROTECTIVE COATINGS USING PAINT REMOVERS	83	52	+31
APPLY MASKING MATERIALS FROM SURFACES	92	62	+30
REMOVE MASKING MATERIALS FROM SURFACES	88	59	+29
APPLY PRIMERS TO SURFACES USING SPRAY METHODS	89	60	+29
PAINT OR STENCIL SIGNS	90	61	+29
SUPERVISE CORROSION CONTROL SPECIALISTS (AFSC 42751)	31	83	-52
PLAN OR SCHEDULE WORK ASSIGNMENTS	24	74	-50
ASSIGN SPONSORS FOR NEWLY ASSIGNED PERSONNEL	8	58	-50
INDORSE AIRMAN PERFORMANCE REPORTS (APRS)	9	58	-49
SCHEDULE LEAVES OR PASSES	8	55	-47
ASSIGN PERSONNEL TO DUTY POSITIONS	24	71	-47
REVIEW DAILY DOCUMENT REGISTERS	12	58	-46

TABLE 16  
 PERCENTAGE TIME SPENT ON DUTIES BY 427X1 AFMS GROUPS

DUTIES	MONTHS AFMS					
	1-48	49-96	97-144	145-192	193-240	241+
ORGANIZING AND PLANNING	1	4	9	10	12	21
DIRECTING AND IMPLEMENTING	1	5	8	9	11	15
INSPECTING AND EVALUATING	1	4	6	10	12	19
TRAINING	*	3	4	6	6	7
WORKING WITH FORMS, RECORDS, REPORTS, DIRECTIVES, AND TECHNICAL DATA	4	7	14	16	20	23
PERFORMING GENERAL CORROSION CONTROL FUNCTIONS	21	17	12	10	8	2
WASHING AIRCRAFT AND AEROSPACE GROUND EQUIPMENT (AGE)	6	6	5	4	4	3
INSPECTING AIRCRAFT, AEROSPACE GROUND EQUIPMENT, (AGE), AND MISSILES	4	4	4	5	5	5
REMOVING CORROSION AND PROTECTIVE COATINGS	16	14	10	9	6	2
TREATING AND PREPARING METAL SURFACES	2	2	2	2	1	*
APPLY PROTECTIVE COATING SYSTEMS	31	23	16	12	8	*
PERFORMING AND PRACTICING DISASTER PREPAREDNESS FUNCTIONS	*	*	1	1	*	*
MAINTAINING CORROSION CONTROL EQUIPMENT	10	10	8	7	5	2
PERFORMING MISSILE DISPATCH FUNCTIONS	*	*	*	*	*	*
PERFORMING MINUTEMAN CORROSION CONTROL FUNCTIONS	*	*	*	*	*	*
PERFORMING TITAN MISSILE CORROSION CONTROL FUNCTIONS	*	*	*	*	1	*

\* DENOTES LESS THAN ONE PERCENT

TABLE 17

## COMMON TASKS PERFORMED BY FIRST-TERM RESPONDENTS IN AFS 427X1

TASK	PERCENT MEMBERS PERFORMING (N=649)
APPLY MASKING MATERIALS TO SURFACES	94
CLEAN WORK AREAS	94
APPLY PRIMERS TO SURFACES USING SPRAY METHODS	90
PAINT OR STENCIL SIGNS	90
REMOVE MASKING MATERIALS FROM SURFACES	89
PERFORM DETAILS	88
PREPARE PRIMERS FOR APPLICATION	85
APPLY POLYURETHANE COATINGS TO SURFACES USING SPRAY METHODS	85
APPLY ENAMELS TO SURFACES USING SPRAY METHODS	85
APPLY LACQUERS TO SURFACES USING SPRAY METHODS	85
PREPARE POLYURETHANE COATINGS FOR APPLICATION	84
WIPE DOWN SURFACES WITH THINNERS PRIOR TO PAINTING	83
SET UP OR TEAR DOWN CONVENTIONAL SPRAY EQUIPMENT	83
PREPARE LACQUERS FOR APPLICATION	82
FABRICATE STENCILS BY MACHINE	82

TABLE 18

MOST COMMON EQUIPMENT UTILIZED BY FIRST TERM RESPONDENTS IN AFS 427X1

<u>EQUIPMENT</u>	<u>PERCENT MEMBERS UTILIZING (N=649)</u>
AEROSOL SPRAY CANS	94
CONVENTIONAL SPRAY PAINT GUNS	92
STENCIL CUTTING MACHINES	93
ABRASIVE PAPERS	89
HAND WIRE BRUSHES	88
PAINT BRUSHES	85
MAINTENANCE STANDS	85
PAINTING SHAKERS	85
PNEUMATIC SANDERS	84
FLASHLIGHTS	82
AIR COMPRESSORS	82
STENCIL KNIVES	77

TABLE 19

MOST COMMON MATERIALS UTILIZED BY FIRST ENLISTMENT  
RESPONDENTS IN AFS 427X1

<u>MATERIALS</u>	<u>PERCENT MEMBERS PERFORMING (N=649)</u>
THINNERS	95
PRIMERS	93
ENAMELS	93
LACQUERS	92
POLYURETHANE COATINGS	89
EPOXY	88
SOLVENTS	81
WALKWAY COATINGS	70
ELASTOMERIC COATINGS	64
STRIPPING TANKS	57
CORROSION PREVENTION COMPOUND (CPC)	55
DRY CLEAN SOLVENT P-D-680	54

TABLE 20

EXPRESSION OF JOB INTEREST, PERCEIVED UTILIZATION OF TALENTS AND TRAINING, AND REENLISTMENT INTENTIONS OF PERSONNEL WITH 1-48 MONTHS TAFMS

	<u>427X1 FIRST-TERM RESPONDENTS (N=649)</u>	<u>1978 COMPARATIVE SAMPLE MISSION EQUIPMENT MAINTENANCE (N=5,881)</u>
<u>I FIND MY JOB:</u>		
NOT REPORTED	1%	3%
DULL	30%	18%
SO-SO	34%	19%
INTERESTING	35%	60%
<u>MY JOB UTILIZES MY TALENTS:</u>		
NOT REPORTED	1%	1%
NOT AT ALL OR VERY LITTLE	39%	33%
FAIRLY WELL TO VERY WELL	57%	61%
EXCELLENTLY OR PERFECTLY	3%	5%
<u>MY JOB UTILIZES MY TRAINING:</u>		
NOT REPORTED	1%	1%
NOT AT ALL OR VERY LITTLE	35%	29%
FAIRLY WELL OR VERY WELL	61%	63%
EXCELLENTLY OR PERFECTLY	3%	7%
<u>DO YOU PLAN TO REENLIST:</u>		
NOT REPORTED	2%	3%
NO OR PROBABLY NO	69%	61%
YES OR PROBABLY YES	29%	36%

## COMPARISON OF SURVEY DATA TO AFR 39-1 SPECIALTY DESCRIPTIONS

Survey data for the 427X1 career ladder were compared to the AFR 39-1 Specialty Descriptions, dated 1 June 1977. These descriptions are intended to give a broad overview of the duties and tasks required to be performed by the various skill level personnel.

Overall, the 3- and 5-skill level descriptions were found to provide a clear, concise overview of the major duties and task performed by these incumbents. However, tasks related to aircraft washing and decontamination were not specifically covered.

The 7-skill level description was found to be a general overview also; however, some discrepancies were discovered. First, there was no specific mention of those tasks related to aircraft washing and decontamination. Second, these incumbents reported spending 45 percent of their job time on technical tasks, while the Specialty Description did not describe the technical tasks these incumbents reported performing in any detail.

Those tasks involving aircraft washing and decontamination for all skill levels and the large percentage of technical tasks performed by 7-skill level incumbents should be reviewed for possible inclusion in the next AFR 39-1 Specialty Description revision.

## ANALYSIS OF CONUS VERSUS OVERSEAS GROUPS

A comparison was made of the tasks performed and the background data for DAFSC 42751 respondents assigned to CONUS versus those in overseas locations. Generally the tasks performed and time spent on those tasks by both groups were the same and involved applying protective coatings, removing corrosion, maintaining corrosion control equipment, and performing general corrosion control functions. However, a larger percentage of overseas incumbents reported spending time on washing contaminated aircraft while a larger percentage of CONUS personnel reported removing, applying, or trimming aircraft decals. CONUS respondents reported performing an average of 106 tasks and had a JDI of 12.2, while overseas personnel performed an average of 102 tasks and had a JDI of 12.1. Table 21 lists those tasks which best differentiate between CONUS and overseas DAFSC 42751 respondents.

A comparison of background data indicated that overseas respondents averaged more time in the service (50 months versus 39 months for CONUS respondents), had a slightly higher average pay-grade (3.8 versus 3.6 for CONUS respondents) and their reenlistment intentions were higher (54 percent planning to reenlist versus 36 percent for CONUS respondents).

The percent members utilizing equipment and materials associated with corrosion control were generally found to be the same. The largest differences were found with a greater percentage (18 percent difference) of overseas respondents utilizing aircraft surface mops and aircraft washing hand brushes than the CONUS respondents.

TABLE 21  
 TASKS WHICH BEST DISTINGUISH BETWEEN DAFSC 42751  
 CONUS AND OVERSEAS GROUPS  
 (PERCENT MEMBERS PERFORMING)

TASKS	CONUS (N=542)	OVERSEAS (N=177)	DIFFERENCE
REMOVE DECALS FROM AIRCRAFT	76	53	+23
APPLY DECALS TO AIRCRAFT	81	66	+15
LIFT OR MOVE EQUIPMENT USING PERMANENT CEILING HOISTS	20	6	+14
CLEAN OR OIL PNEUMATICALLY POWERED TOOLS	73	60	+13
TRIM DECALS WITH EDGE SEALER	72	59	+13
REMOVE CORROSION USING METALLIC WOOLS	37	25	+12
CLEAN DRY SPRAY BOOTHS	29	17	+12
WASH OR PRACTICE WASHING CONTAMINATED AIRCRAFT USING BRUSHES	8	33	-25
APPLY CLEANING SOLUTIONS TO AIRCRAFT	26	46	-20
RINSE AIRCRAFT	20	39	-19
DIRECT OR PRACTICE DIRECTING AIRCRAFT DECONTAMINATION OPERATIONS	7	25	-18
VISUALLY INSPECT AIRCRAFT OR PARTS TO DETERMINE TYPE OF CLEANING SOLUTION NEEDED	20	36	-16
DIRECT WASHING OF AIRCRAFT	27	42	-15
WASH OR PRACTICE WASHING CONTAMINATED AIRCRAFT BY USING FIRE HOSES	7	21	-14
APPLY WASH PRIMERS TO SURFACES USING SPRAY METHODS	32	46	-14

## ANALYSIS OF TASK DIFFICULTY

The relative difficulty of each task in the task inventory was assessed through ratings by 52 experienced 7- and 9-skill level Corrosion Control NCOs. These ratings were processed to produce an ordered listing of all tasks in terms of their relative difficulty and were standardized to have an average difficulty of 5.0 (Standard Deviation equals 1.0). (For a more complete description of these ratings, see the Task Factor Administration section in the INTRODUCTION.)

Table 22 lists those tasks rated the most difficult by 427X1 personnel. All of these tasks were supervisory in nature; however, those tasks related to training or financial management and contracting, such as developing CDCs or reviewing corrosion control contracts, were consistently rated among the most difficult tasks performed. It was interesting to note that none of these more difficult tasks were performed by more than 12 percent of the total 427X1 sample.

Most of the tasks rated average in task difficulty seemed to be related to protective coatings applications or removal (see Table 23). Some of these tasks include preparing wash primers for application and removing protective coatings using paint removers. Generally, these tasks are performed by a larger percentage of the 427X1 sample than the more difficult tasks.

Table 24 lists those tasks rated the least difficult by 427X1 personnel. These tasks primarily involved facilities or corrosion control equipment maintenance, such as adding oil to compressors or draining shop air lines. Tasks consistently rated the easiest were the house-keeping tasks, such as cleaning and waxing of government vehicles.

### Job Difficulty Index (JDI)

The Job Difficulty Index (JDI) for each job type, cluster, or independent job type is listed in both the CAREER LADDER STRUCTURE section and Appendix A. For clarity, Table 25 lists the functional jobs found in the CAREER LADDER STRUCTURE with their associated JDIs. Experienced Craftsmen had a JDI of 20.5, the highest found for any cluster or independent job type. These incumbents reported performing 130 more tasks than the other groups. This fact plus the difficult supervisory tasks these incumbents performed would explain the high JDI.

Corrosion Control Supervisors had a JDI of 16.4 and performed a variety of technical and supervisory tasks, many of which were rated above average in difficulty. These respondents performed an average of 103 tasks, the second highest for clusters and independent job types.

Generally, the lowest JDIs were associated to the Aircraft Washer Personnel cluster and the independent job types. These groups reported performing less than 45 tasks which was somewhat less than the other cluster personnel performed. Also, many of the tasks performed usually involved general corrosion control functions, washing aircraft, or applying protective coatings, which were typically rated below average in difficulty.

TABLE 22

## TASKS RATED MOST DIFFICULT BY 427X1 PERSONNEL

TASKS	TASK DIFFICULTY	PERCENT MEMBERS PERFORMING (N=1,122)
DRAFT TITAN PAINT PLANS	7.55	5
CONDUCT RESIDENT COURSE CLASSROOM TRAINING	7.43	4
ACT AS A TRAINING ADVISOR AT STAFF LEVEL	7.36	5
DEVELOP CAREER DEVELOPMENT COURSES (CDCs)	7.34	5
DEVELOP RESIDENT COURSE CURRICULUM MATERIALS	7.27	3
ADVISE TECHNICAL REPRESENTATIVES OF CONTRACT OFFICE (TRCO) PROCUREMENT OFFICIALS DURING CORROSION CONTRCT DISPUTES	7.14	7
DRAFT CORROSION CONTROL CONTRACTS	7.12	5
DRAFT BUDGET OR FINANCIAL REQUIREMENTS	7.09	7
ESTABLISH ORGANIZATION POLICIES, OFFICE INSTRUCTIONS (OIs) OR STANDING OPERATING PROCEDURES (SOPs)	7.02	11
CONDUCT STAFF MEETINGS	7.00	6
ASSIGN RESIDENT COURSE INSTRUCTORS	7.00	4
EVALUATE BUDGETING OR FINANCIAL REQUIREMENTS	6.98	6
REVIEW CORROSION CONTROL CONTRACTS	6.85	10
DEVELOP PHASE TESTS	6.81	5
CONDUCT TITAN SITE SUPERVISORY VISITATIONS	6.80	3
DEVELOP SPECIALTY TRAINING STANDARDS (STs)	6.80	6
INTERPRET CORROSION CONTROL CONTRACTS	6.77	7

TABLE 23

## TASKS RATED ABOUT AVERAGE IN DIFFICULTY BY 427X1 PERSONNEL

TASKS	TASK DIFFICULTY	PERCENT MEMBERS PERFORMING (N=1,122)
MAINTAIN CONTRACTOR MAINTENANCE RECORDS	5.05	8
APPLY CHROMATE CONVERSION COATINGS USING SPRAY METHODS	5.03	25
PERFORM OPERATOR MAINTENANCE ON ELECTROSTATIC SPRAY EQUIPMENT	5.03	7
PREPARE WASH PRIMERS FOR APPLICATION	5.03	35
APPLY LACQUERS TO SURFACES USING BRUSHES	5.02	28
RESEARCH TECHNICAL DATA TO IDENTIFY PROTECTIVE COATINGS	5.02	43
PERFORM OPERATOR MAINTENANCE ON AIRLESS SPRAY EQUIPMENT	5.00	19
ASSIGN OJT TRAINERS	4.99	14
LIFT OR MOVE EQUIPMENT USING FORKLIFTS	4.99	15
SCORE TESTS	4.99	6
REMOVE PROTECTIVE COATINGS USING PAINT REMOVERS	4.99	76
REVIEW PERSONNEL EVALUATION REPORT FORMS	4.99	14
APPLY ENAMELS TO SURFACES USING SPRAY METHODS	4.97	78
PREPARE MIL-M-10578 METAL CONDITIONER OR RUST REMOVER FOR FERROUS METALS, STAINLESS STEEL, OR COPPER	4.97	17
APPLY PRIMERS TO SURFACES USING SPRAY METHODS	4.94	82

TABLE 24

## TASKS RATED LEAST DIFFICULT BY 427X1 PERSONNEL

TASKS	TASK DIFFICULTY	PERCENT MEMBERS PERFORMING (N=1,122)
WASH GOVERNMENT VEHICLES	1.74	25
EMPTY VACUUM CLEANERS	1.98	15
WAX GOVERNMENT VEHICLES	2.28	17
ATTACH OR REMOVE STATIC GROUNDS	2.36	61
REMOVE OR REPLACE VACUUM CLEANER BAGS	2.41	8
SKIM MATERIALS OFF WET SPRAY BOOTH WATER	2.44	38
DRAIN SHOP AIR LINES	2.58	48
ASSIGN SPONSORS FOR NEWLY ASSIGNED PERSONNEL	2.69	18
ADD OIL TO COMPRESSORS	2.83	27
WASH DOWN AIRCRAFT WASHING AREAS	2.87	27
INITIATE TEMPORARY ISSUE RECEIPT FORMS (AF FORM 1297)	2.89	29
TIGHTEN LOOSE NUTS OR BOLTS	2.91	23
REPLENISH CHARCOAL IN CHARCOAL FILLED AIR SEPARATORS	2.96	10
APPLY TRAFFIC PAINT TO CHOCKS USING BRUSHES	2.98	15
CLEAN WORK AREAS	3.01	86
REPLENISH SAND IN VACUUM BLASTERS	3.06	14

TABLE 25  
JOB DIFFICULTY INDICES FOR CAREER LADDER GROUPS

<u>CLUSTERS/JOB TYPES/INDEPENDENT JOB TYPES</u>	<u>JOB DIFFICULTY INDEX</u>
EXPERIENCED CRAFTSMEN (GRP116)	20.5
SENIOR CRAFTSMEN (GRP251)	22.6
GENERAL CRAFTSMEN (GRP242)	19.1
TITAN CORROSION CONTROL SUPERVISORS (GRP137)	19.8
APPLICATIONS AND REMOVAL PERSONNEL (GRP105)	11.7
APPLICATIONS CRAFTSMEN (GRP359)	14.9
APPLICATIONS JOURNEYMEN (GRP324)	11.7
APPLICATIONS SUPERVISORS (GRP254)	16.9
APPLICATIONS APPRENTICES (GRP208)	8.9
MECHANICAL REMOVAL PERSONNEL (GRP144)	9.0
CAMOUFLAGE APPLICATORS (GRP135)	7.1
SPRAY PAINTERS (GRP132)	7.6
MISSILE CORROSION PERSONNEL (GRP093)	11.8
TITAN CORROSION JOURNEYMEN (GRP098)	12.8
MINUTEMAN CORROSION JOURNEYMEN (GRP175)	8.2
MINUTEMAN INSPECTION MEMBERS (GRP220)	13.4
CORROSION REMOVAL PERSONNEL (GRP074)	7.6
AIRCRAFT WASHER PERSONNEL (GRP027)	7.5
AIRCRAFT WASHER JOURNEYMEN (GRP089)	7.1
AIRCRAFT INSPECTORS (GRP096)	7.2
CORROSION CONTROL SUPERVISORS (GRP026)	16.4
NCOICs CORROSION CONTROL (GRP111)	14.7
CORROSION CONTROL SHOP CHIEFS (GRP207)	19.1
FABRICATION BRANCH SUPERVISORS (GRP253)	19.2
WASH RACK SUPERVISORS (GRP075)	13.2
QUALITY CONTROL PERSONNEL (GRP084)	15.7
FLIGHTLINE DISPATCHERS (GRP054)	9.6

## ANALYSIS OF TRAINING EMPHASIS

The relative training emphasis of each task in the inventory was assessed through ratings of 50 experienced 7- and 9-skill level Corrosion Control NCOs. These ratings were processed to produce an ordered listing of all tasks in terms of their recommended emphasis in training of first enlistment personnel. These ratings had an average of 2.7 and a standard deviation of 1.9. (For a more complete description of these ratings see the section on TASK FACTOR ADMINISTRATION in the INTRODUCTION.) Training emphasis becomes important when evaluating specialty training documents, such as the Specialty Training Standard (STS) and specialty Plan of Instruction (POI).

Table 26 lists those tasks rated highest in training emphasis by 427X1 personnel. These tasks seem to involve either corrosion or protective coating removal, or protective coating application. It was interesting to note that most of these tasks were performed by a majority of the total 427X1 group.

Table 27 lists those tasks that were rated about average by 427X1 personnel. These tasks seem to involve two areas of corrosion control, these being corrosion control administration and equipment operation or maintenance. Generally, these tasks are performed by a smaller percentage of 427X1 personnel than the tasks rated high in training emphasis.

Finally, Table 28 lists those tasks rated low in training emphasis. These tasks seem to be related to either general housekeeping or corrosion control equipment maintenance. It is interesting to note that very few technical tasks involving applying or removing protective coatings were rated low in training emphasis. Also, these tasks seem to be performed by smaller percentages of 427X1 personnel than either those tasks rated high or average in training emphasis.

TABLE 26

TASKS RATED HIGHEST IN TRAINING EMPHASIS BY 427X1 PERSONNEL

TASKS	TRAINING EMPHASIS	PERCENT OF FIRST ENLISTMENT PERSONNEL PERFORMING (N=649)
IDENTIFY TYPES OF CORROSION	7.5	69
PREPARE AFTO FORMS 349	7.3	58
IDENTIFY CAUSES OF CORROSION	7.0	51
APPLY PRIMERS TO SURFACES USING SPRAY METHODS	6.9	90
IDENTIFY CAUSES OF PROTECTIVE COATING FAILURES	6.9	52
APPLY POLYURETHANE COATINGS TO SURFACES USING SPRAY METHODS	6.9	86
PREPARE POLYURETHANE COATINGS FOR APPLICATION	6.8	84
SET UP OR TEAR DOWN CONVENTIONAL SPRAY EQUIPMENT	6.7	83
PREPARE PRIMERS FOR APPLICATION	6.7	85
REMOVE PROTECTIVE COATINGS USING PAINT REMOVERS	6.6	83
IDENTIFY TYPES OF PROTECTIVE COATING FAILURES	6.5	45
APPLY DECALS TO AIRCRAFT	6.5	78
APPLY EPOXY COATINGS TO SURFACES USING SPRAY METHODS	6.4	80
APPLY LACQUERS TO SURFACES USING SPRAY METHODS	6.4	85
IDENTIFY METALS BY RESEARCHING TECHNICAL DATA	6.3	25

TABLE 27

## TASKS RATED AVERAGE IN TRAINING EMPHASIS BY 427X1 PERSONNEL

TASKS	TRAINING EMPHASIS	PERCENT OF FIRST ENLISTMENT PERSONNEL PERFORMING (N=649)
FINISH SAND SURFACES USING ELECTRIC BUFFERS OR GRINDERS	2.9	10
PERFORM ACCEPTANCE INSPECTIONS OF AIRCRAFT OF WHICH CONTRACT WORK WAS PERFORMED	2.8	10
INSPECT CHEMICAL TANKS	2.8	10
ESTABLISH BENCH STOCK REQUIREMENTS	2.8	13
IMPLEMENT SAFETY PROGRAMS	2.8	5
REPLENISH SAND IN SAND BLASTERS	2.8	31
COORDINATE WITH ENVIRONMENTAL ENGINEERING ON CHEMICAL DISPOSAL	2.8	8
INITIATE PERSONNEL AVAILABILITY FORECAST FORMS (AF FORM 2405)	2.8	6
EVALUATE NEW EQUIPMENT	2.8	8
INSPECT AREAS FOR CORROSION USING BORESCOPES	2.7	10
EVALUATE RED X CONDITIONS	2.7	8
OPERATE HIGH REACHES OR CHERRY PICKERS	2.7	19
TEAR DOWN AIRCRAFT WASHING EQUIPMENT	2.7	15

TABLE 28

## TASKS RATED LOW IN TRAINING EMPHASIS BY 427X1 PERSONNEL

TASKS	TRAINING EMPHASIS	PERCENT OF FIRST ENLISTMENT PERSONNEL PERFORMING (N=649)
HAND WIPE MISSILE SURFACES	.4	5
WRAP NONDRIP TAPE AROUND PIPES	.5	3
FILL BOILERS	.6	3
APPLY RUNWAY MARKINGS	.7	10
SET UP OR TEAR DOWN AGE	.8	17
WASH GOVERNMENT VEHICLES	1.2	26
BURY OR PRACTICE BURYING CONTAMINATED ITEMS	1.2	4
STEAM OUT TANKS OR BARRELS	1.3	4
REMOVE OR REPLACE AIRCRAFT PANELS	1.3	11
WASH AGE	1.3	9
MAINTAIN REQUISITION FILES	1.4	3

## WRITE-IN COMMENTS

Generally, the write-in comments reflected a fair state of morale in the 427X1 career ladder. However, some comments centered around frustrations from primarily three areas: (1) the lack of corrosion control actually done at certain bases; (2) safety and T.O. violations, and (3) the possibility of DAFSC 541X0G personnel assuming Minuteman corrosion control tasks.

A large number of write-in comments stated 427X1 personnel did not perform actual corrosion control on aircraft, AGE, or missiles, but instead painted trucks, signs, garbage cans, etc. These statements may have some validity, since 86 percent of the total 427X1 sample reported painting or stenciling signs.

A few comments stated that "aircraft are shoved into the hangar with no notice and needed to be painted by the next day... the T.O. and safety rules can't possibly be adhered to." Another respondent wrote in about "cosmetic" corrosion control which he felt had potential safety hazards.

Finally, some 427X1 personnel associated with the Minuteman missile system stated the corrosion control tasks they performed could easily be accomplished by DAFSC 541X0G personnel. The 541X0G STS has a corrosion control section in it, and comments from the field state this section would cover all of the corrosion control tasks 427X1 personnel currently perform on the Minuteman missile system.

As stated previously, the majority of the write-in comments reflected a fair state of morale in the 427X1 career field. However, some problem areas were identified, and should be taken into consideration when changes are made in the career field.

## COMPARISON TO PREVIOUS SURVEY

The results of this 427X1 survey were compared to those of Occupational Survey Report, AFPT-90-535-149 dated 1 March 1975. Generally, both studies were very similar; only slight differences were found in three areas.

First-term respondents were compared on their perceptions of their job, and slightly more of the current respondents perceived their job as interesting (35 percent versus 32 percent) and more perceived they utilized their talents and training (63 percent versus 52 percent). However, fewer of the current first-term respondents plan to reenlist (29 percent versus 34 percent).

There were some task differences noted between the two studies. Seventeen percent of the job time of the previous 427X1 sample was spent washing or inspecting aircraft or age. Currently 427X1 personnel spend about eight percent of their job time on these tasks.

There are several explanations for this trend. One possible explanation is that some aircraft washing is currently being contracted, therefore, 427X1 personnel would spend less time in these areas. Another explanation could be the reduced number of 427X1 personnel overseas compared to the previous survey. As stated in the CONUS/Overseas section, overseas personnel were differentiated because of the larger percentage of these incumbents performing wash related tasks. Therefore, if a smaller percentage of the current career field is overseas, then overall percentage of time spent on washing will be smaller.

The career ladder structure appeared to be very stable, and only one slight difference was noted. Technical Training Instructors identified in the previous survey did not cluster together in the current survey. Instead, 427X1 personnel were found in both the Experienced Craftsmen and Corrosion Control Supervisors cluster; and did not group into a single separate job type.

## IMPLICATIONS

While the tasks and jobs involved in Air Force corrosion control activities have remained relatively stable in recent years, there are several trends which have emerged in the course of this survey which could impact on the career field. These include low numbers of first enlistment personnel who intend to reenlist, potential hazards resulting from alleged "cosmetic" painting, and possible duplication of Minutemen corrosion control training between this specialty and AFS 541X0G.

The lower than normal reenlistment intent of first-term corrosion control specialists could lead to manning problems in the career field in the future if this trend is not closely monitored. However, some commands appear to enjoy manning of 100 percent or more in this specialty, so that the impact of possible low reenlistment may be small. Overall, the morale in the career field appears good (judging from write-in comments).

Several write-in comments by members of the specialty involved the amount of "cosmetic" painting being done (which is alleged to include painting trucks, signs, garbage cans, etc). Participants suggest that this unnecessary "cosmetic" painting was a safety hazard.

Another potential problem area is the possible duplication of training between this specialty and AFS 541X0G for corrosion control for the Minuteman missile system. Write-ins by several 427X1 personnel pointed out that STS 541X0G contains a section on corrosion control tasks normally performed on the Minuteman missile by 427X1 specialists. If this is accurate, it may be possible to reduce training in one specialty or the other through a management decision as to which AFSC should have responsibility for these Minuteman tasks.

With these few exceptions, there appears to be no major problems or issues involving the 427X1 career field at this time. Overall, morale appears good, career field documents (AFR 39-1, STS) appear realistic, and training is supported by survey data.

APPENDIX A

TABLE I

RELATIVE TIME SPENT ON DUTIES BY THE JOB TYPES IN THE EXPERIENCED CRAFTSMEN CLUSTER

DUTIES	SENIOR CRAFTSMEN (GRP251, N=89)	GENERAL CRAFTSMEN (GRP242, N=55)	TITAN CORROSION CONTROL SUPERVISORS (GRP137, N=5)
ORGANIZING AND PLANNING	9		2
DIRECTING AND IMPLEMENTING	7	2	7
INSPECTING AND EVALUATING	8	2	10
TRAINING	5	2	9
WORKING WITH FORMS, RECORDS, REPORTS, AND, TECHNICAL DATA	14	4	12
PERFORMING GENERAL CORROSION CONTROL FUNCTIONS	10	15	11
WASHING AIRCRAFT AND AEROSPACE GROUND EQUIPMENT (AGE)	5	7	*
INSPECTING AIRCRAFT, AEROSPACE GROUND EQUIPMENT (AGE) AND MISSILES	4	4	3
REMOVING CORROSION AND PROTECTIVE COATINGS	11	18	12
TREATING AND PREPARING METAL SURFACES	2	4	2
APPLYING PROTECTIVE COATING SYSTEMS	14	25	8
PERFORMING AND PRACTICING DISASTER PREPAREDNESS FUNCTIONS	*	*	*
MAINTAINING CORROSION CONTROL EQUIPMENT	9	13	6
PERFORMING MISSILE DISPATCH FUNCTIONS	9	*	4
PERFORMING MINUTEMAN CORROSION CONTROL FUNCTIONS	*	*	1
PERFORMING TITAN MISSILE CORROSION CONTROL FUNCTIONS	*	*	9

\* DENOTES LESS THAN ONE PERCENT

TABLE II  
BACKGROUND INFORMATION BY JOB TYPES IN THE EXPERIENCED CRAFTSMEN CLUSTER

	<u>SENIOR CRAFTSMEN</u>	<u>GENERAL CRAFTSMEN</u>	<u>TITAN CORROSION CONTROL SUPERVISORS</u>
AVERAGE NUMBER OF TASKS PERFORMED	287	207	166
AVERAGE PAY GRADE	5.4	3.8	5.8
AVERAGE NUMBER OF PERSONNEL SUPERVISED	5.2	1.2	6.4
JOB DIFFICULTY INDEX (JDI)	22.6	19.1	19.8
DAFSC:			
42731	1%	16%	0%
42751	32%	70%	0%
42771	67%	14%	100%
AVERAGE MONTHS IN CAREER LADDERS	110	54	133
AVERAGE MONTHS TAFMS	124	59	173
PERCENT IN FIRST ENLISTMENT	12%	51%	0%

TABLE III

JOB INTEREST AND RELATED DATA BY JOB TYPES IN THE EXPERIENCED CRAFTSMEN CLUSTER  
(PERCENT RESPONDING)

	<u>SENIOR CRAFTSMEN</u>	<u>GENERAL CRAFTSMEN</u>	<u>TITAN CORROSION CONTROL SUPERVISORS</u>
<u>I FIND MY JOB:</u>			
NO RESPONSE	6	4	0
DULL	17	16	20
SO-SO	11	31	20
INTERESTING	66	49	60
<u>MY JOB UTILIZES MY TALENTS:</u>			
NO RESPONSE	18	22	20
NOT AT ALL TO VERY LITTLE	64	71	80
FAIRLY WELL TO VERY WELL	18	7	0
EXCELLENTLY TO PERFECTLY			
<u>MY JOB UTILIZES MY TRAINING:</u>			
NO RESPONSE	2	4	20
NOT AT ALL TO VERY LITTLE	18	16	20
FAIRLY WELL TO VERY WELL	62	62	60
EXCELLENTLY TO PERFECTLY	18	18	0
<u>I PLAN TO REENLIST:</u>			
NO RESPONSE	3	0	0
NO	18	26	20
PROBABLY NO	14	16	20
PROBABLY YES	11	26	20
YES	54	32	60

TABLE IV

RELATIVE PERCENT TIME SPENT ON DUTIES BY THE JOB TYPES IN THE APPLICATIONS AND REMOVAL PERSONNEL CLUSTER

DUTIES	APPLICATIONS CRAFTSMEN (GRP359, N=150)	APPLICATIONS JOURNEYMEN (GRP324, N=198)	APPLICATIONS SUPERVISORS (GRP254, N=16)	APPLICATIONS APPRENTICES (GRP208, N=182)	MECHANICAL REMOVAL PERSONNEL (GRP144, N=18)
ORGANIZING AND PLANNING	3	1	5	*	1
DIRECTING AND IMPLEMENTING	3	1	7	*	2
INSPECTING AND EVALUATING	2	1	4	*	2
TRAINING	1	*	3	*	*
WORKING WITH FORMS, RECORDS, DIRECTIVES, AND TECHNICAL DATA	5	3	13	2	2
PERFORMING GENERAL CORROSION CONTROL FUNCTIONS	16	20	13	2	2
WASHING AIRCRAFT AND AEROSPACE GROUND EQUIPMENT (AGE)	8	4	6	3	*
INSPECTING AIRCRAFT, AEROSPACE GROUND EQUIPMENT (AGE); AND MISSILES	5	5	4	3	4
REMOVING CORROSION AND PROTECTIVE COATINGS	16	18	12	16	21
TREATING AND PREPARING METAL SURFACES	3	2	2	1	2
APPLYING PROTECTIVE COATING SYSTEMS	25	34	21	40	21
PERFORMING AND PRACTICING DISASTER PREPAREDNESS FUNCTIONS	*	*	*	*	*
MAINTAINING CORROSION CONTROL EQUIPMENT	12	11	9	9	14
PERFORMING MISSILE DISPATCH FUNCTIONS	*	*	*	*	*
PERFORMING HINUTEMAN CORROSION CONTROL FUNCTIONS	*	*	*	*	*
PERFORMING TITAN MISSILE CORROSION CONTROL FUNCTIONS	*	*	*	*	*

\* DEMOTES LESS THAN ONE PERCENT

TABLE V  
 BACKGROUND INFORMATION BY JOB TYPES IN THE APPLICATIONS AND REMOVAL PERSONNEL CLUSTER

	APPLICATIONS CRAFTSMEN	APPLICATIONS JOURNEYMEN	APPLICATIONS SUPERVISORS	APPLICATIONS APPRENTICES	MECHANICAL REMOVAL PERSONNEL
AVERAGE NUMBER OF TASKS PERFORMED	132	94	146	65	67
AVERAGE PAY GRADE	3.7	3.3	4.8	3.1	3.7
AVERAGE NUMBER OF PERSONNEL SUPERVISED	.6	.2	3.8	.1	0
JOB DIFFICULTY INDEX (JDI)	14.9	11.7	16.9	8.9	9.0
DAFSC:					
42731	11%	16%	0%	28%	0%
42751	79%	81%	44%	71%	94%
42771	10%	13%	56%	1%	6%
AVERAGE MONTHS IN CAREER LADDER					
AVERAGE MONTHS TAFMS	46	30	94	24	39
PERCENT IN FIRST ENLISTMENT	50	34	99	28	43
	63%	84%	13%	89%	83%

TABLE VI

JOB INTEREST AND RELATED DATA BY JOB TYPES IN THE APPLICATIONS AND REMOVAL PERSONNEL CLUSTER  
(PERCENT MEMBERS RESPONDING)

	APPLICATIONS CRAFTSMEN	APPLICATIONS JOURNEYMEN	APPLICATIONS SUPERVISORS	APPLICATIONS APPRENTICES	MECHANICAL REMOVAL PERSONNEL
<u>I FIND MY JOB:</u>					
NO RESPONSE	1	3	6	3	0
DULL	21	26	19	34	28
SO-SO	38	36	19	35	33
INTERESTING	40	35	56	28	39
<u>MY JOB UTILIZES MY TALENTS:</u>					
NO RESPONSE	0	0	0	2	0
NOT AT ALL TO VERY LITTLE	29	36	12	45	55
FAIRLY WELL TO VERY WELL	66	61	82	51	34
EXCELLENTLY TO PERFECTLY	5	3	6	2	11
<u>MY JOB UTILIZES MY TRAINING:</u>					
NO RESPONSE	0	1	0	2	0
NOT AT ALL TO VERY LITTLE	23	31	25	39	66
FAIRLY WELL TO VERY WELL	69	66	75	57	23
EXCELLENTLY TO PERFECTLY	8	2	0	2	11
<u>I PLAN TO REENLIST:</u>					
NO RESPONSE	2	2	0	2	6
NO	26	39	6	45	44
PROBABLY NO	19	25	6	26	11
PROBABLY YES	27	22	19	18	17
YES	26	12	69	9	??

TABLE VII

RELATIVE PERCENT TIME SPENT ON DUTIES BY THE JOB TYPES IN THE MISSILE CORROSION PERSONNEL CLUSTER

DUTIES	TITAN CORROSION JOURNEYMEN (GRP098, N=18)	MINUTEMAN CORROSION JOURNEYMEN (GRP175, N=9)	MINUTEMAN INSPECTION MEMBERS (GRP220, N=10)
ORGANIZING AND PLANNING	1	*	2
DIRECTING AND IMPLEMENTING	2	1	3
INSPECTING AND EVALUATING	*	*	2
TRAINING	1	*	3
WORKING WITH FORMS, RECORDS, REPORTS, DIRECTIVES, AND TECHNICAL DATA	2	2	4
PERFORMING GENERAL CORROSION CONTROL FUNCTIONS	21	22	20
WASHING AIRCRAFT AND AEROSPACE GROUND EQUIPMENT (AGE)	*	*	*
INSPECTING AIRCRAFT, AEROSPACE GROUND EQUIPMENT (AGE), AND MISSILES	5	5	5
REMOVING CORROSION AND PROTECTIVE COATINGS	17	16	18
TREATING AND PREPARING METAL SURFACES	4	2	2
APPLYING PROTECTIVE COATING SYSTEMS	14	17	16
PERFORMING AND PRACTICING DISASTER PREPAREDNESS FUNCTIONS	*	*	*
MAINTAINING CORROSION CONTROL EQUIPMENT	5	4	8
PERFORMING MISSILE DISPATCH FUNCTIONS	6	7	5
PERFORMING MINUTEMAN CORROSION CONTROL FUNCTIONS	*	22	12
PERFORMING TITAN MISSILE CORROSION CONTROL FUNCTIONS	21	*	*

\* DENOTES LESS THAN ONE PERCENT

TABLE VIII

## BACKGROUND INFORMATION BY JOB TYPES IN THE MISSILE CORROSION PERSONNEL CLUSTER

	TITAN CORROSION JOURNEYMEN	MINUTEMAN CORROSION JOURNEYMEN	MINUTEMAN INSPECTION MEMBERS
AVERAGE NUMBER OF TASKS PERFORMED	92	61	114
AVERAGE PAY GRADE	2.9	3.7	4.4
AVERAGE NUMBER OF PERSONNEL SUPERVISED	.3	0	.4
JOB DIFFICULTY INDEX (JDI)	12.8	8.2	13.4
DAFSC:			
42731	28%	11%	0%
42751	72%	89%	90%
42771	0%	0%	10%
AVERAGE MONTHS IN CAREER LADDER			
AVERAGE MONTHS TAFMS	30	34	71
PERCENT IN FIRST ENLISTMENT	35	35	77
	83%	78%	40%

TABLE IX  
 JOB INTEREST AND RELATED DATA BY JOB TYPES IN THE MISSILE CORROSION PERSONNEL CLUSTER  
 (PERCENT RESPONDING)

	TITAN CORROSION JOURNEYMEN	MINUTEMAN CORROSION JOURNEYMEN	MINUTEMAN INSPECTION MEMBERS
<u>I FIND MY JOB:</u>			
NO RESPONSE			
DULL	0	0	0
SO-SO	28	55	10
INTERESTING	28	22	50
	44	23	40
<u>MY JOB UTILIZES MY TALENTS:</u>			
NO RESPONSE			
NOT AT ALL TO VERY LITTLE	0	0	10
FAIRLY WELL TO VERY WELL	61	67	10
EXCELLENTLY TO PERFECTLY	39	33	80
<u>MY JOB UTILIZES MY TRAINING:</u>			
NO RESPONSE			
NOT AT ALL TO VERY LITTLE	0	0	0
FAIRLY WELL TO VERY WELL	33	89	20
EXCELLENTLY TO PERFECTLY	67	11	70
	0	0	10
<u>I PLAN TO REENLIST:</u>			
NO RESPONSE			
NO	0	0	0
PROBABLY NO	28	22	10
PROBABLY YES	22	33	30
YES	28	22	10
	22	23	50

TABLE X  
RELATIVE PERCENT TIME SPENT ON DUTIES BY JOB TYPES IN THE  
AIRCRAFT WASHER PERSONNEL CLUSTER

DUTIES	AIRCRAFT WASHER JOURNEYMEN (GRP089, N=5)	AIRCRAFT INSPECTORS (GRP096, N=8)
ORGANIZING AND PLANNING	2	3
DIRECTING AND IMPLEMENTING	4	8
INSPECTING AND EVALUATING	2	4
TRAINING	2	*
WORKING WITH FORMS, RECORDS, REPORTS, DIRECTIVES AND TECHNICAL DATA	6	6
PERFORMING GENERAL CORROSION CONTROL FUNCTIONS	47	23
WASHING AIRCRAFT AND AEROSPACE GROUND EQUIPMENT (AGE)	25	33
INSPECTING AIRCRAFT, AEROSPACE GROUND EQUIPMENT (AGE), AND MISSILES	5	2
REMOVING CORROSION AND PROTECTIVE COATINGS	6	7
TREATING AND PREPARING METAL SURFACES	*	2
APPLYING PROTECTIVE COATING SYSTEMS	*	6
PERFORMING AND PRACTICING DISASTER PREPAREDNESS FUNCTIONS	*	*
MAINTAINING CORROSION CONTROL EQUIPMENT	*	5
PERFORMING MISSILE DISPATCH FUNCTIONS	*	*
PERFORMING MINUTEMAN CORROSION CONTROL FUNCTIONS	*	*
PERFORMING TITAN MISSILE CORROSION CONTROL FUNCTIONS	*	*

\* DENOTES LESS THAN ONE PERCENT

TABLE XI

BACKGROUND INFORMATION OF JOB TYPES IN THE AIRCRAFT WASHER PERSONNEL CLUSTER

	<u>AIRCRAFT WASHER JOURNEYMEN</u>	<u>AIRCRAFT INSPECTORS</u>
AVERAGE NUMBER OF TASKS PERFORMED	44	46
AVERAGE PAY GRADE	3.8	3.9
AVERAGE NUMBER OF PERSONNEL SUPERVISED	0	6
JOB DIFFICULTY INDEX (JDI)	7.1	7.2
<hr/>		
DAFSC:		
42731	20%	12%
42751	80%	75%
42771	0%	13%
<hr/>		
AVERAGE MONTHS IN CAREER LADDER	47	56
AVERAGE MONTHS TAFMS	48	62
PERCENT IN FIRST ENLISTMENT	40%	38%

TABLE XII

JOB INTEREST AND RELATED DATA BY JOB TYPES IN  
THE AIRCRAFT WASHER PERSONNEL CLUSTER  
(PERCENT RESPONDING)

	<u>AIRCRAFT WASHER JOURNEYMEN</u>	<u>AIRCRAFT INSPECTORS</u>
<u>I FIND MY JOB:</u>		
NO RESPONSE	0	0
DULL	20	0
SO-SO	60	87
INTERESTING	20	13
<u>MY JOB UTILIZES MY TALENTS:</u>		
NO RESPONSE	0	0
NOT AT ALL TO VERY LITTLE	40	38
FAIRLY WELL TO VERY WELL	60	62
EXCELLENTLY TO PERFECTLY	0	0
<u>MY JOB UTILIZES MY TRAINING:</u>		
NO RESPONSE	0	0
NOT AT ALL TO VERY LITTLE	40	50
FAIRLY WELL TO VERY WELL	60	50
EXCELLENTLY TO PERFECTLY	0	0
<u>I PLAN TO REENLIST:</u>		
NO RESPONSE	0	0
NO	40	38
PROBABLY NO	20	0
PROBABLY YES	40	25
YES	0	37

TABLE XIII

RELATIVE PERCENT TIME SPENT ON DUTIES BY THE JOB TYPES IN THE CORROSION CONTROL SUPERVISORS CLUSTER

DUTIES	NCOLCS CORROSION CONTROL (GRF11, N=9)	CORROSION CONTROL SHOP CHIEFS (GRP207, N=6)	FABRICATION BRANCH SUPERVISORS (GRP253, N=43)	WASH RACK SUPERVISORS (GRP075, N=8)	QUALITY CONTROL PERSONNEL (GRP084, N=6)	FLIGHTLINE DISPATCHERS (GRP055, N=8)
ORGANIZING AND PLANNING	12	11	16	9	8	20
DIRECTING AND IMPLEMENTING	11	11	14	12	4	17
INSPECTING AND EVALUATING	8	10	15	8	18	10
TRAINING	6	9	9	8	10	7
WORKING WITH FORMS, RECORDS, REPORTS, DIRECTIVES AND TECHNICAL DATA	22	17	26	6	18	37
PERFORMING GENERAL CORROSION CONTROL FUNCTIONS	9	12	4	11	6	6
WASHING AIRCRAFT AND AEROSPACE GROUND EQUIPMENT (AGE)	2	4	3	13	*	*
INSPECTING AIRCRAFT, AEROSPACE GROUND EQUIPMENT (AGE) AND MISSILES	9	3	5	7	6	2
REMOVING CORROSION AND PROTECTIVE COATINGS	6	6	2	6	3	*
TREATING AND PREPARING METAL SURFACES	*	1	*	2	*	*
APPLYING PROTECTIVE COATING SYSTEMS	8	10	1	12	*	2
PERFORMING AND PRACTICING DISASTER PREPAREDNESS FUNCTIONS	*	*	*	*	*	*
MAINTAINING CORROSION CONTROL EQUIPMENT	6	5	4	6	2	*
PERFORMING MISSILE DISPATCH FUNCTIONS	*	*	*	*	6	*
PERFORMING MINUTEMAN CORROSION CONTROL FUNCTIONS	*	*	*	*	9	*
PERFORMING TITAN MISSILE CORROSION CONTROL FUNCTIONS	*	*	*	*	8	*

\* DENOTES LESS THAN ONE PERCENT

TABLE XIV

BACKGROUND INFORMATION BY THE JOB TYPES IN THE CORROSION CONTROL SUPERVISORS CLUSTER

	<u>NCOICs</u>	<u>CORROSION</u>	<u>FABRICATION</u>	<u>WASH RACK</u>	<u>QUALITY</u>	<u>FLIGHTLINE</u>
	<u>CORROSION</u>	<u>CONTROL</u>	<u>BRANCH</u>	<u>SUPERVISORS</u>	<u>CONTROL</u>	<u>DISPATCHERS</u>
	<u>CONTROL</u>	<u>SHOP CHIEFS</u>	<u>SUPERVISORS</u>	<u>SUPERVISORS</u>	<u>PERSONNEL</u>	<u>DISPATCHERS</u>
AVERAGE NUMBER OF TASKS PERFORMED	88	159	125	75	76	30
AVERAGE PAY GRADE	5	6	6.4	5.2	5.3	4.9
AVERAGE NUMBER OF PERSONNEL SUPERVISED	2.3	2.6	6.7	4.5	3.0	2.3
JOB DIFFICULTY INDEX (JDI)	14.7	19.1	19.2	13.2	15.7	9.6

DAFSC:

42731	0%	0%	0%	0%	0%	0%
42751	67%	17%	8%	25%	17%	50%
42771	33%	83%	92%	75%	83%	50%

AVERAGE MONTHS IN CAREER FIELD

84	124	133	94	106	116
114	165	188	121	116	135
11%	0%	0%	0%	33%	25%

AVERAGE MONTHS TAFMS

PERCENT IN FIRST ENLISTMENT

TABLE XV

JOB INTEREST AND RELATED DATA BY JOB TYPES IN THE CORROSION CONTROL SUPERVISORS CLUSTER  
(PERCENT RESPONDING)

	NCOICs CORROSION CONTROL	CORROSION CONTROL SHOP CHIEFS	FABRICATION BRANCH SUPERVISORS	WASH RACK SUPERVISORS	QUALITY CONTROL PERSONNEL	FLIGHTLINE DISPATCHERS
<u>I FIND MY JOB:</u>						
NO RESPONSE	11	17	2	0	0	0
DULL	22	17	9	25	0	12
SO-SO	0	0	14	25	0	12
INTERESTING	67	66	75	50	100	76
<u>MY JOB UTILIZES MY TALENTS:</u>						
NO RESPONSE	0	0	5	0	0	0
NOT AT ALL TO VERY LITTLE	22	17	14	37	17	25
FAIRLY WELL TO VERY WELL	78	83	70	63	66	62
EXCELLENTLY TO PERFECTLY	0	0	11	0	17	13
<u>MY JOB UTILIZES MY TRAINING:</u>						
NO RESPONSE	0	0	0	0	0	0
NOT AT ALL TO VERY LITTLE	22	17	9	38	33	12
FAIRLY WELL TO VERY WELL	78	66	72	62	34	63
EXCELLENTLY TO PERFECTLY	0	17	19	0	33	25
<u>I PLAN TO REENLIST:</u>						
NO RESPONSE	11	0	7	0	0	0
NO	11	33	16	38	17	12
PROBABLY NO	0	0	9	12	0	12
PROBABLY YES	0	0	14	38	17	38
YES	78	67	54	12	66	38