

AD-A079 714

SEAWARD INTERNATIONAL INC FALLS CHURCH VA
OIL POLLUTION RESPONSE PLANNING GUIDE FOR EXTREME WEATHER, (U)
NOV 79

F/G 6/6

DOT-CG-80372-A

UNCLASSIFIED

USCG-D-3-80

NL

1 OF 3

AD
A079714



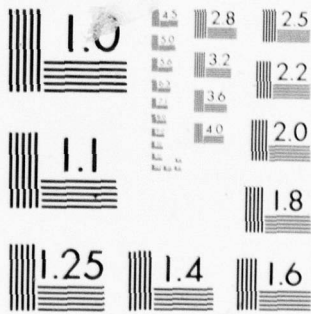

MICROCOPY RESOLUTION TEST CHART
NATIONAL BUREAU OF STANDARDS-1963-A

Report No. CG-D-3-80

LEVEL III

12
B.S.

ADA 079714

OIL POLLUTION RESPONSE PLANNING GUIDE
FOR EXTREME WEATHER



Document is available to the public through the
National Technical Information Service,
Springfield, Virginia 22151

DDC
RECEIVED
JAN 22 1980
D

DDC FILE COPY

Prepared for

**U.S. DEPARTMENT OF TRANSPORTATION
United States Coast Guard
Office of Research and Development
Washington, D.C. 20590**

80 1 22 017

1. Report No. CG-D-3-80	2. Government Accession No. USCG	3. Recipient's Catalog No.	
4. Title and Subtitle OIL POLLUTION RESPONSE PLANNING GUIDE FOR EXTREME WEATHER		5. Report Date November 16, 1979	6. Performing Organization Code
7. Author(s)		8. Performing Organization Report No.	
9. Performing Organization Name and Address Seaward International, Inc. 6269 Leesburg Pike Falls Church, Virginia 22044		10. Work Unit No. (TRAIS) 4113	11. Contract or Grant No. DOT-CG-80372-A
12. Sponsoring Agency Name and Address Department of Transportation United States Coast Guard Office of Research and Development Washington, DC 20593		13. Type of Report and Period Covered	
15. Supplementary Notes		14. Sponsoring Agency Code G-DMT-4	
16. Abstract <p>This Guide is intended to provide the On-Scene Coordinator with information and guidance useful in developing action plans and contingency plans for conducting oil pollution response operations in open water. The Guide considers two general categories of response operations at sea:</p> <ol style="list-style-type: none"> 1. Prevention of (further) spillage from tanker and other vessel casualties. 2. Oil spill mitigation and cleanup . <p>The following types of information are presented in the guide:</p> <ol style="list-style-type: none"> 1. Outlines for Action Plans. 2. Planning guidance. 3. Requirements for initial casualty assessment. 4. Roles of ship's master, Salvor, other key personnel. 5. Description of response system and equipment options. 6. Data needs for use in selecting appropriate response approach. 7. Selection criteria for deciding between alternative response approaches. 8. Checklists for various types of the response operations. 9. Sources for additional information. 			
17. Key Words		18. Distribution Statement Document is available to the U. S. public through the National Technical Information Service, 5285 Port Royal Road, Springfield, Virginia 22161	
19. Security Classif. (of this report) Unclassified	20. Security Classif. (of this page) Unclassified	21. No. of Pages 240	22. Price

410 055

net

METRIC CONVERSION FACTORS

Approximate Conversions to Metric Measures

Symbol	When You Know	Multiply by	To Find	Symbol
	LENGTH			
in	inches	2.5	centimeters	cm
ft	feet	30	centimeters	cm
yd	yards	0.9	meters	m
mi	miles	1.6	kilometers	km
	AREA			
sq ft	square inches	6.5	square centimeters	cm ²
sq ft	square feet	0.09	square meters	m ²
sq yd	square yards	0.8	square meters	m ²
sq mi	square miles	2.6	square kilometers	km ²
	acres	0.4	hectares	ha
	MASS (weight)			
oz	ounces	28	grams	g
lb	pounds	0.45	kilograms	kg
	short tons (2000 lb)	0.9	tonnes	t
	VOLUME			
teaspoon	teaspoons	5	milliliters	ml
Tablespoon	tablespoons	15	milliliters	ml
fluid ounce	fluid ounces	30	milliliters	ml
cup	cup	0.24	liters	l
pt	pints	0.47	liters	l
qt	quarts	0.95	liters	l
gal	gallons	3.8	liters	l
cu ft	cubic feet	0.03	cubic meters	m ³
cu yd	cubic yards	0.76	cubic meters	m ³
°F	Fahrenheit temperature	5/9 (after subtracting 32)	Celsius temperature	°C

Approximate Conversions from Metric Measures

Symbol	When You Know	Multiply by	To Find	Symbol
	LENGTH			
mm	millimeters	0.04	inches	in
cm	centimeters	0.4	inches	in
m	meters	3.3	feet	ft
km	kilometers	1.1	yards	yd
		0.6	miles	mi
	AREA			
cm ²	square centimeters	0.16	square inches	sq in
m ²	square meters	1.2	square yards	sq yd
km ²	square kilometers	0.4	square miles	sq mi
ha	hectares (10,000 m ²)	2.5	acres	acres
	MASS (weight)			
g	grams	0.035	ounces	oz
kg	kilograms	2.2	pounds	lb
t	tonnes (1000 kg)	1.1	short tons	short tons
	VOLUME			
ml	milliliters	0.03	fluid ounces	fl oz
l	liters	2.1	pints	pt
l	liters	1.06	quarts	qt
l	liters	0.26	gallons	gal
m ³	cubic meters	35	cubic feet	ft ³
m ³	cubic meters	1.3	cubic yards	yd ³
°C	Celsius temperature	9/5 (then add 32)	Fahrenheit temperature	°F

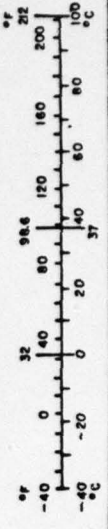
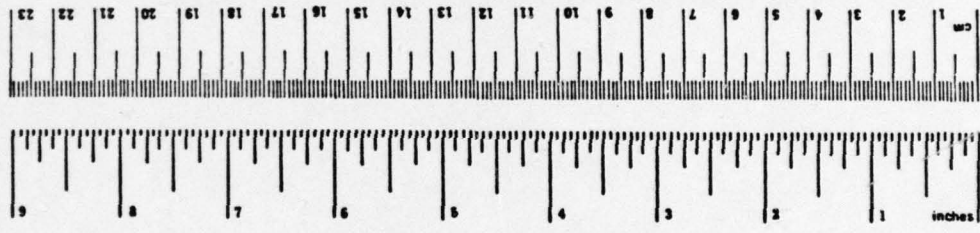

* 1 in = 2.54 (exact). For other exact conversions and more detailed tables, see NBS Misc. Publ. 286, Units of Weights and Measures, Price \$1.25, SO Catalog No. C13.10286.

TABLE OF CONTENTS

<u>Section Number</u>	<u>Page Number</u>
1.0 INTRODUCTION	1
2.0 GENERAL	4
2.1 Action Plan	4
2.2 Effect of Weather on General Pollution Response Operations	8
2.3 Time Plans	9
2.4 Initial Assessment of Casualty Situation.	10
2.5 Other Information Sources	12
3.0 PREVENTION OF OIL SPILLAGE FROM VESSEL CASUALTIES.	24
3.1 Response Guidelines for Tanker Casualties	25
3.2 Response Alternatives	27
3.3 Response System Descriptions	31
3.3.1 Approach: Off-Load Cargo to a Receiving Vessel	33
3.3.2 Approach: Jettison Part of Cargo	46
3.3.3 Approach: Bomb the Vessel and Burn the Cargo In-Situ	52
3.3.4 Approach: Cargo Gelling	57
4.0 OIL SPILL MITIGATION AND CLEAN-UP	59
4.1 Response System Selection	61
4.2 Response System Descriptions	64
4.2.1 Approach: Vessel-of-Opportunity Skimming System (VOSS)	65
4.2.2 Approach: Container Barrier Assisted Skimming	75
4.2.3 Approach: Dedicated Skimmer	88
4.2.4 Approach: Dispersants, Vessel Applied	95
4.2.5 Approach: Dispersants, Aircraft Applied	105
4.2.6 Approach: Microbial Elimination of Oil Spills	113
4.2.7 Approach: Slick Burning	115

Accession For	
NTIS GRA&I	<input checked="" type="checkbox"/>
DDC TAB	<input type="checkbox"/>
Unannounced Justification	<input type="checkbox"/>
By _____	
Distribution/ _____	
Availability Codes	
Dist.	Avail and/or special
A	

LIST OF FIGURES

Figure No.	Title	Page No.
3.1	Time Effects on Casualty Life and Response Approach	26
3.2	Example of Cumulative Effects of Response Time and Casualty Life	28
3.3	Mooring System for Off-Loading Stranded Tanker in Higher Sea States	38
3.4	Time Plans for Cargo Off-Loading and Ship Ballasting	40
3.5	Decision Process for Determining the Feasibility of Off-Loading	41
3.6	Decision Process for Determining the Feasibility of Ballasting and Stabilizing	42
3.7	Decision Process for Determining the Feasibility of Jettisoning	49
4.1	Selection of a Spill Response Approach	62
4.2	Time Plans for Vessel-of-Opportunity Skimming System (VOSS) and Dedicated Skimmer	70
4.3	Vessel-of-Opportunity Skimming System (VOSS) Considerations	71
4.4	Independent Skimmer and Barrier with Distant Ship Support - Before Launching	77
4.5	Independent Skimmer and Barrier with Distant Ship Support - Fully Deployed	79
4.6	Barrier Use Considerations	83
4.7	Time Plan for Skimmer Independent of Barrier	84
4.8	Dedicated Skimmer Considerations	92
4.9	Dispersant System - Vessel Approach	96

LIST OF FIGURES (Cont'd)

Figure No.	Title	Page No.
4.10	Time Plans for Vessel-Applied Dispersant System and Aircraft-Applied Dispersant System . . .	100
4.11	Vessel-Applied Dispersant System Considerations . .	101
4.12	Aircraft-Applied Dispersant System Considerations .	109

LIST OF TABLES

Table No.	Title	Page No.
2.1	Action Plan Guidelines	5
2.2	Significant Wave Height Ranges for Various Sea States	9
2.3	Scenarios for Example Time Plan Diagrams	11
2.4	Casualty Situation and Spill Assessment	13
3.1	Sea State Operational Limits for Response Approaches	32
3.2	Off-Loading -- Planning Checklist	43
3.3	Jettisoning -- Planning Checklist	50
3.4	Bombing and/or Explosives -- Planning Checklist	55
4.1	Spill Mitigation and Cleanup	60
4.2	VOSS -- Planning Checklist	72
4.3	Barrier Systems -- Planning Checklist	85
4.4	Dedicated Skimmer -- Planning Checklist	93
4.5	Dispersants, Vessel-Applied -- Planning Checklist	102
4.6	Dispersants, Aircraft-Applied -- Planning Checklist	110
5.1	Emergency Cargo Pumps	118
5.2	Flow Handling Capabilities of Various Hose Sizes (gpm).	119
5.3	Oil Skimmer Capabilities	121
5.4	Oil Boom Capabilities	126
5.5	Dispersant System Capabilities	134
5.6	Typical Oil Receiving Vessels	136
5.7	Typical Workboats	138

1.0 INTRODUCTION

This Guide is intended to provide the On-Scene Coordinator (OSC) with information and guidance useful in developing action plans and contingency plans for conducting oil pollution response operations in open water. The Guide considers two general categories of response operations at sea:

1. Prevention of (further) spillage from tanker and other vessel casualties.
2. Oil Spill mitigation and cleanup.

The following types of information are presented in the guide:

1. Outlines for Action Plans.
2. Planning guidance.
3. Requirements for initial casualty assessment.
4. Roles of ship's Master, Salvor, other key personnel.
5. Description of response system and equipment options.
6. Data needs for use in selecting appropriate response approach.
7. Selection criteria for deciding between alternative response approaches.
8. Checklists for various types of the response operations.
9. Sources for additional information.

Background is provided on state-of-the-art (SOA) techniques and systems that can be employed in pollution response situations. This document also provides a decision-making guide in certain cases for selecting the preferred approach in view of the sea state, casualty parameters, and other environmental conditions. The examples given and the criteria stated may be combinations of parameters that may be encountered in actual operations. Therefore, the action of the OSC must be based on the actual conditions that exist, or that are expected to exist within the time frame of the response operation.

Likewise, no hard and fast rules exist on how to deploy and operate the various systems discussed. In many cases the details of the possible system components are unknown at this time (tow vessels, receiving and other containers, mooring systems, etc.), and procedures for integrating the components into efficient systems have not been developed. The OSC must determine what is available to him in the event of an emergency, and probably develop some of his own methods for using them. The Strike Teams and the U.S. Navy Supervisor of Salvage (SUPSALV) can be valuable in assisting the OSC in this area, and practice operations should be undertaken whenever possible. Cleanup contractors in some cases, as well as operators of nearby Navy oil spill cleanup equipment, can also be helpful in establishing satisfactory procedures.

Although this Guide summarizes many of the considerations in responding to real or potential oil spill incidents, it will not ensure the OSC of making the correct response decision in all cases. This Guide does not provide a cookbook approach to handling a pollution incident, and it is not a handbook of pollution response details to pull out and use only when an incident occurs. It will be most valuable as a planning tool, presenting items that an OSC should consider in the event of an incident, and general approaches to planning operations and making basic decisions. Many of these decisions should also incorporate the advice of other people, such as salvors, equipment operators, EPA and other government regulatory officials, Strike Team members, and other pollution experts.

As new response systems become available, this Guide should be updated to include discussions of these systems, and an effort should be made to evaluate their sea state and weather capabilities with respect to existing systems. New information on the capabilities of existing systems should also be factored into periodic updatings. Unfortunately, operating or test data are lacking or are subject to various interpretations in many of the

existing approaches considered, and therefore, the extremes in the system capabilities discussed in this Guide represent more engineering and operational judgments than actual operating experience. (1) Realistic appraisals of system performance, on the part of the users and developers or manufacturers, will be to everyone's benefit in oil pollution response planning and operation.

2.0 GENERAL

This section deals with general considerations in planning for an open-water, high-sea-state oil pollution response operation, whether it be an actual spill, or a potential spill involving a stricken oil carrier. Topics covered include:

- . Action Plans
- . Extreme weather effects
- . Time Plans
- . Initial assessment of casualty situations
- . Information sources

2.1 Action Plans

Plans to deal with spills or potential spills at specific locations within the OSC's area of responsibility should be included in local contingency plans as directed by COMDTINST 16465.10. These Action Plans should anticipate the probable types of incidents and the areas that should be protected in the event of a spill. They should also outline the steps that should be taken to combat a hypothetical spill at this location.

The purpose of Action Plans is to minimize the delays involved in planning and executing control and cleanup operations when an accident does occur. Although no individual plan can hope to anticipate all aspects of a situation, by careful examination of prevailing environmental conditions (by season), location of environmentally sensitive areas, and examination of potential accident sites, much can be done to increase the probability of achieving a successful response with minimal time delay.

No format is specified for Action Plans, although several types of information should be included, and some common procedures can be practiced. An example of the information types and common procedures that can be included in an Action Plan is given in Table 2.1. To avoid unnecessary duplication, specific Action

TABLE 2.1
ACTION PLAN GUIDELINES

1. Region covered by specific plan
2. Type(s) of pollution incidents covered in this plan
 - a. Passive responses likely to be required (booming of sensitive areas, booming around stricken vessel, booming around shoreside discharge point, etc.)
 - b. Active responses likely to be required (skimming, beach cleanup for un-boomed areas, casualty vessel off-loading, etc.)
3. Location(s) of pollution incident - likely accident areas, etc.
4. Sensitive areas requiring protection - primary, secondary.
5. Prevailing environmental conditions (by season - winds, currents, etc.) at all locations of interest.
6. Probable effects on sensitive areas from accidents at specific locations - matrix format (resource location vs. accident location, for various seasons if significant, and for various accident types or magnitudes). Based on probable combinations of accidents and sensitive area locations, estimate:
 - a. Time available to establish protection of sensitive areas
 - b. Most effective command post locations - primary, secondary
 - c. Equipment and personnel needs
 - d. Location of nearest sources of required containment/control equipment, boats, and personnel (including commercial and other governmental sources)
 - e. Location of most suitable mobilization and deployment sites
 - f. Tentative booming plans for initial protection of sensitive areas
7. Initial response procedures
 - a. Upon notification of an actual or impending casualty:
 - Make required notifications and establish lines of communications (see local contingency plans - include polluter, owner, etc.)
 - Make on-site assessment of the situation - utilize consultants, if necessary.
 - Prepare to assume command of the incident
 - Commence monitoring the situation
 - b. If command of the incident is assumed (or is imminent) the following steps should be taken; not necessarily in this order:

TABLE 2.1 (Continued)

- Review status of personnel, equipment, and systems available to be deployed to the scene (military and commercial).
 - Review alternative courses of action based on continuing assessment and preplanned responses.
 - Make decision on course of action, including location of command post, mobilization/deployment sites, and initial allocation of response resources.
- c. Upon selecting the course of action to be taken, perform the following actions, not necessarily in this order:
- Mobilize and deploy government and contractor equipment.
 - Arrange for emergency charters of appropriate floating plant (barges, tugs, etc.), aircraft, etc.
 - Establish a command post to include the functions called for in the local contingency plans and pollution response bill.
 - Prepare and carry out operations orders, as required.
 - Perform other functions, as necessary.

Plans should minimize the amount of information already contained in local Contingency Plans. See enclosure (14) to COMDTINST 16465.10 for guidance in developing the inputs to Action Plans.

Both "active" and "passive" responses should be included in Action Plans. "Active responses" are defined as those in which an effort is made to remove the pollutant from the environment before it reaches sensitive areas. "Passive responses" are defined as those in which a sensitive area is protected from pollution damage by booming off the area. Obviously, in the presence of a spill both types of action may be required. Active responses may involve booming to contain the spread of oil and aid in skimming before shore areas are affected. Active responses for slick control may also include slick dispersion, in-situ burning, and other techniques discussed in Section 4 of this Guide. An active response that is not discussed is beach cleanup, where existing methods involving intensive manual labor must be applied.

In the event of a vessel casualty, where there is a potential for stopping or preventing spillage, active responses may involve pumping the cargo or bunkers to other tanks or another vessel, jettisoning cargo (to save the bulk of the cargo from spilling), or other techniques to be discussed in Section 3. In this case, a passive response may involve booming around the casualty to contain any oil spilled during transfer operations.

Most elements of Action Plans will depend on the local situation and conditions, and on the equipment locally available. However, where major pollution incidents are possible, such as in areas of open water and heavy tanker or barge traffic, and/or where extreme weather conditions exist, plans should reach beyond local sources to include Strike Teams, Navy Supervisor of Salvage (SUPSALV), and commercial operators of specialized equipment. One of the purposes of this Guide is to provide background information on the types

of response approaches and equipment that may be considered for emergency use, especially in extreme weather, but which may not be available locally.

Where it is feasible, Action Plans should include Time Plans (See Section 2.3) that indicate the scheduling problems, key events, and potential bottlenecks that can occur in carrying out a response operation. Time Plans, when compared with the time available to respond (before severe damage is done), will help to determine whether or not a particular response method is worth using in the case at hand. Example Time Plans are presented for several response approaches in Sections 3 and 4.

Checklists will also be valuable in ensuring preparedness for utilizing a particular approach. These lists indicate the important information that must be on hand or quickly obtainable before decisions are made, the equipment selections that have to be made, sub-plans for carrying out specific operations within the scope of the overall response method, and contingency plans in case of failure of the principal approach.

2.2 Effect of Weather on General Pollution Response Operations

Bad weather can halt or delay any type of response operation. In the case of small spills the failure of a response operation because of bad weather can usually be tolerated if the ensuing cleanup operation is not too difficult. Where spills are large, or potentially large, the effects of bad weather can be far more serious, and the problems of dealing with or working around the weather should be given special attention. Providing guidance for dealing with the weather problem is one of the aims of this Guide.

Generally, the most difficult problem imposed by bad weather is the wave conditions (Sea State) generated in open water. High waves will make most boom and skimming devices ineffective. Waves and wind can cause difficulty in off-loading casualty vessels, as well as threatening the remaining integrity of the casualty. Sea states, for purposes of this Guide, are defined by significant wave height ($H_{1/3}$) ranges, as shown in Table 2.2, for fully-developed, wind-driven seas (see also Reference 2). The term "extreme weather" will

be used to refer to Sea State 4 and above. Other aspects of bad weather, such as cold, precipitation, wind, etc., can also reduce the effectiveness of pollution responses, but these can usually be dealt with in conventional ways not unique to open water situations.

TABLE 2.2. SIGNIFICANT WAVE HEIGHT RANGES FOR VARIOUS SEA STATES

<u>Sea State</u>	<u>Range of $H_{1/3}$, feet</u>
0	0 - 0.1
1	0.1 - 1.2
2	1.2 - 3.1
3	3.1 - 5.4
4	5.4 - 7.5
5	7.5 - 12.5
6	12.5 - 20.0

In extended operations where the weather could be a problem, the equipment selected for use in response operations should be capable of operating, or at least surviving, in the sea conditions anticipated. In an actual response operation, updated local weather forecasts should be obtained continuously. Navy meteorologists and the National Weather Service can provide this information. The OSC may access information from Navy meteorologists via the Regional Response Team. Private (commercial) weather forecasting services can also be utilized. For planning purposes, statistical information is available on the persistence of favorable or unfavorable seas at various points along the U.S. coastline. (3) The operating limits for equipment and systems are estimated in later sections.

2.3 Time Plans

The Time Plans referred to in Section 2.1 can be prepared as time-line diagrams similar to Critical Path Method (CPM) or PERT charts. Examples are shown throughout the Guide for specific response methods.

Although other methods of estimating response time requirements can be used, the time-line approach has several advantages:

- a. The interrelationship of all of the significant steps in performing the response can be shown.
- b. Steps that must be completed before subsequent steps can be taken are indicated.
- c. After the estimated times to complete the steps are placed on the diagram, a "critical path" can be mapped, indicating the sequence that requires the greatest total time to complete the response. Ways to reduce the time requirements along the critical path steps can then be investigated. (Note: The length of the step line or its location on the page has no significance.)
- d. Changes in the critical path can be determined if variations or ranges for the time estimate for various steps are assumed.
- e. Any degree of complexity can be used in the diagram. However, because of the number of variables involved in a typical response operation, a relatively simple diagram is recommended for planning purposes, showing only the major steps.
- f. Progress during an actual operation can be monitored with the aid of this type of time plan.

The Time Plan examples shown in the response examples are based on a representative scenario, which is described in Table 2.3. The times shown are only rough estimates. For example, if tugs and barges are readily available near the site of an anticipated casualty, a relatively short response time could be utilized, based on actual estimates by the owner/operator. Sequences of events and special approaches should also be based on what the OSC determines will function best in his area of responsibility.

2.4 Initial Assessment of Casualty Situation

A rapid and thorough assessment of the casualty situation or spill is necessary in order to aid in initial decision making. The assessment should generally include determination of the casualty type, casualty vessel characteristics, oil characteristics (cargo data), damage estimate, and environmental data.

TABLE 2.3

SCENARIOS FOR EXAMPLE TIME PLAN DIAGRAMS

For a grounded tanker that is leaking oil:

1. Oil Viscosity: Medium crude - 30 cs (0.87 s.g.)
2. Sea Conditions: Operate: 19 knot wind, $H_{1/3} = 6.9$ ft.
Survive: 29 knot wind, $H_{1/3} = 15.7$ ft.
3. Oil Quantity: 100,000-DWT Tanker
4. Other Casualty Features:
 - . Location: 25 miles offshore, 50 miles from nearest staging area, 200 miles from nearest major supply center.
 - . Vessel grounded - holed and leaking - speed at grounding approx. 8 knots.
 - . Vessel power systems inoperative
 - . List 10°
 - . Trim negligible
5. Oil leakage Rate: 1000 gpm average outflow rate
6. Slick features:
 - . At 1 mile from source: thin slick, 2000 ft. wide, with thickness 0.03mm; 400 ft. wide windrow in center of slick, containing elongated oil pancakes 5mm thick and 100x200 ft. in area (90% of oil).
 - . Wind/wave driven slick velocity 0.7 kts, in addition to tidal current of 2 kts. max.
7. Other Environmental Features;
 - . Diurnal tidal current of 2 kts maximum
 - . Tide range is 3 ft.
 - . Sea Temperature 4°C
 - . Air Temperature 0°C
 - . Intermittent precipitation
 - . Minimal debris present

This information will be useful to the salvor as well as the OSC and his staff. The information must be collected and reported rapidly and accurately. Some information can be obtained through a phone patch with the ship's Master,⁽⁸⁾ but the fullest information cannot be obtained this way.

Response personnel conducting the assessment should be thoroughly trained in the techniques required. Several types of personnel may be called upon to perform this function, such as:

- Officer from the Marine Safety Office (MSO) or the Captain of the Port (COTP), delivered by helicopter. This person is likely to be the first person on board the stricken vessel, other than the ship's Master and crew.
- A knowledgeable MSO/Marine Inspection Office (MIO) inspector. This person should be immediately dispatched to the casualty even though intervention has not taken place.
- Strike Team personnel. However, to wait for a Strike Team may take too long.
- Search and Rescue (SAR) vessel Damage Control Officer. Such a vessel may not be nearby, however.

Table 2.4 presents a listing of assessment items that could be important in a casualty situation. Not every item would be significant in every likely response approach; however, having all of the information available will aid in evaluating alternative responses. The information should be relayed to the OSC as it is developed. As the casualty situation changes, either because of changing environmental conditions or through progression of the response operation, the situation should be reassessed, and updated information should be relayed to the OSC.

2.5 Other Information Sources

Each casualty situation can be expected to differ in some way from any others, and the OSC will probably require outside assistance in dealing with a potential vessel spill situation. Some of the more important inputs to come from outside the Coast Guard chain of command will include:

TABLE 2.4. CASUALTY SITUATION AND SPILL ASSESSMENT

INFORMATION	PURPOSE	SOURCE	COMMENTS
CASUALTY (SHIP) SITUATION			
<u>Casualty Type</u>	General information	Ship's Master	Language barrier is a problem
<u>Vessel Data</u>	Mainly for salvage considerations (Appendices C & D)	Ship's drawings/data	Builder/owner may have additional information
Type of vessel	"	"	"
Length	"	"	"
Beam	"	"	"
Draft (actual, before damage)	"	Ship's log	Accuracy may be questionable
Freeboard (actual, before damage)	"	"	"
Trim (actual, before damage)	"	"	"
Structural details	"	Ship's drawings/data	Builder/owner may have additional information
Air pressure capacity of tank tops	"	"	"
Tank/piping layout	"	"	"
Pump location/performance features (head, capacity)	"	"	"
Type/location of auxiliary power	"	"	"
Hoses, emergency gear on hand	Salvage/pump-off considerations	Crew	
Hydrostatic data	Ground reaction/Salvage calculations	Ship's records/calculations	Check builder/owner
Tons per inch immersion (TPI)	Estimates, grounding point	"	"
Moment to change trim one inch (MIT)	Damage estimates/salvage calculations	"	"
Damage stability curves	Estimating losses	Ship's data	
Tank capacities as function of trim/list and depth or ullage			

TABLE 2.4. (Cont'd)

INFORMATION	PURPOSE	SOURCE	COMMENTS
<p>Data on Cargo (Tankers), Fuel Oil, and/or Lube Oil</p>	<p>Help in confirming properties (Appendix E)</p>	<p>Ship log/sampling</p>	<p>Bad weather may make sampling hazardous or difficult</p>
<p>Oil type in each tank</p>	<p>Estimate of loss; salvage calculations</p>	<p>Ship's log</p>	<p>Loss of power can cause temperature drop</p>
<p>Initial Quantity in each tank</p>	<p>Help in confirming viscosity</p>	<p>Measurement</p>	<p>Increases with temperature drop</p>
<p>Temperature</p>	<p>For pumping calculations</p>	<p>Data/Measurement</p>	
<p>Viscosity</p>	<p>For salvage calculations</p>	<p>Data/Measurement</p>	
<p>Density</p>	<p>Estimate of loss; salvage calculations</p>	<p>Ship's Log</p>	
<p>Initial liquid depth</p>	<p>Estimate of loss; salvage calculations</p>	<p>"</p>	
<p>Initial Ullage</p>	<p>For protective equipment requirements, precautions</p>	<p>Ship's log/CIIRIS data/HACS</p>	
<p>Hazardous properties</p>			
<p><u>Damage Estimate</u></p>	<p>Determine grounding point and force (Appendix D)</p>	<p>1) Visual waterline marks 2) Freeboard measurements</p>	<p>Difficult and unsafe in bad weather Waves need to be compensated (electrical wave gauge) Bow or stern decks could be awash</p>
<p>Actual drafts upon grounding</p>	<p>Aid in determining grounding point, degree of damage and tank contents</p>	<p>Gauges on vessel</p>	
<p>Trim</p>	<p>"</p>	<p>"</p>	
<p>List</p>	<p>"</p>	<p>"</p>	
<p>Ullage in all tanks (or depth of liquid)</p>	<p>Determine change in cargo, volume, and therefore damage indication</p>	<p>Direct measurement, probably by crew</p>	<p>May vary if vessel shifts with waves on the strand</p>

TABLE 2.4. (Cont'd)

INFORMATION	PURPOSE	SOURCE	COMMENTS
Depth of oil/water interface (if any)	Determining which tanks have damage (including piping), and degree of oil loss and water intrusion	Thieving paste, electronic gauges	Gauges may not be readily available
Rate of level change	Indicates leakage or ingress rate	Direct measurements at time intervals	Change divided by time interval gives approximate rate
Location of breached tanks, or tanks with damaged piping	Salvage input, determining which tanks to pump off first	1) Air velocity through ullage connection (indicating direct tank opening to waves) 2) Deductions from other measurements and calculations	
Amount of hog/sag	Indicates load condition on ship and degree of stress/strain on critical structural components	1) Taut line from bow to pilot house 2) Strain gauges 3) Deck wrinkle 4) Paint Distortion	Measurements must be continued during salvage operations
Status of ship's components: Engine room and engines Emergency generator Steering gear Cargo pumps Piping Pilot house Inerting system	Planning response " " " " "	Inspection by crew " " " " "	
Location of grounding point	Salvage planning	Estimate (calculation)/diver inspection "	
Ground reaction	"	Inspection - probably underwater	Difficult to ascertain in rough weather. Diver inspection probably required.
Type of grounding (impalement or otherwise)	Indicates type of salvage approach required	Direct observations	Ship can change position
Orientation of ship (heading with respect to compass, seas, winds, current)	Planning salvage-type operations		

TABLE 2.4. (Cont'd)

INFORMATION	PURPOSE	SOURCE	COMMENTS
<p>Size/location of holes</p> <p>Permissible approach distance (fire, explosion, hazard, etc.)</p> <p><u>Environmental Data</u> (Present and projected, where applicable)</p> <p>Time/date of casualty</p> <p>Position</p> <p>Tidal cycle/height</p> <p>Currents</p> <p>Wind speed and direction</p> <p>Precipitation/visibility</p> <p>Temperature</p> <p>Sea conditions (sea state)</p> <p>Proximity of environmentally sensitive areas</p> <p>Bottom topography</p> <p><u>Oil Slick Data</u></p> <p>Oil Rate</p>	<p>Planning pumping/salvage operations</p> <p>To determine safe operating limits (Appendix A)</p> <p>Estimating conditions at time of casualty</p> <p>Affects salvage approach (Appendix F)</p> <p>"</p> <p>"</p> <p>"</p> <p>"</p> <p>"</p> <p>"</p> <p>Affects salvage cleanup approach</p> <p>May help to determine reaction force around stranded vessel</p> <p>Planning cleanup approach (Appendices B & H)</p>	<p>Inspection/Calculations</p> <p>Overall evaluation of cargo, damage, and situation</p> <p>Crew</p> <p>Crew</p> <p>Weather service, charts</p> <p>"</p> <p>Direct observation/weather service</p> <p>"</p> <p>"</p> <p>"</p> <p>Contingency plans</p> <p>Charts/diver inspection/soundings around vessel/bottom samples</p> <p>Measurement/estimation</p>	<p>Difficult to determine underwater</p> <p></p> <p></p> <p></p> <p></p> <p></p> <p></p> <p></p> <p></p> <p></p> <p></p> <p></p> <p>These areas should be identified independently of any casualties</p> <p>Most all of these sources may be necessary to determine conditions. Diving may be hazardous.</p> <p>Only an average rate can probably be determined</p>

TABLE 2.4. (Cont'd)

INFORMATION	PURPOSE	SOURCE	COMMENTS
Oil Type (viscosity on water, amount of weathering)	Planning oil cleanup and disposal	Slick sampling and measurement	May be hazardous in bad weather
Thickness	Planning cleanup approach	Direct measurement/sampling	"
Area covered	"	Aerial and vessel observation	Poor visibility of bad weather may complicate
Wind or wave driven velocity and direction	Slick trajectory prediction	Measurement or forecasting	Coast Guard oceanographic unit can provide spill trajectory forecasting
Existence of windrows, pools, etc.	Planning cleanup approach	Aerial or vessel observation	Poor visibility of bad weather may complicate
Spreading and break-up of slick (description of state of slick)	"	Direct observation and trajectory forecasting	Forecasting by Coast Guard oceanographic unit
Volume in slick at any time	Planning cleanup and estimating potential environmental damage	Estimation based on spilled and recovered amounts	Only a gross estimate is possible
Debris present	Planning cleanup approach	Direct Observation	

- Ship's Master and owner
- Salvor
- Owners and operators of commercial or other government response equipment

Ship's Master and owner: The ship's Master and owner are the most knowledgeable parties regarding the vessel's cargo, equipment, and current condition. Thus, the OSC should pay particular attention to their recommendations and encourage the Master's direct participation in the casualty response. However, should the Master and the OSC disagree on a course of action, and if there is an imminent threat of a major pollution incident as a result of the casualty, the OSC may override the objections of the Master under authority of the Intervention on the High Seas Act (33 USC 1476) and the Clean Water Act Amendments of 1977, section 311(c) (33 USC 1321). Final authority for action under the Intervention on the High Seas Act is retained by the Commandant. Guidance on the use of the Act may be found in COMDTINST 16453.1.

The Master and crew are invaluable sources of information in a vessel-related incident, by virtue of the following:

- They are intimately familiar with the layout and working of the vessel.
- They should know what the events were leading to the casualty, and what actions have been taken up to the present.
- They can be helpful in developing additional data needed for planning the pollution response and/or salvage operations.
- The Master has access to the ship's plans and data carried on board. Also, all of the cargo information is accessible to him.
- The crew can have initiated response operations, such as transferring cargo, etc., before anyone else has gotten involved.
- Many subsequent response operations can be performed by, or with the assistance of, the crew, such as operating the ship's pumps and systems, etc.

One problem in dealing with the Master or crew is the language barrier, which, with foreign crews, can result in real communications problems. Further information on the ship's Master's role during an accident at sea can be found in Reference 8.

Salvor: By the term "salvor" is meant any and all people with special knowledge and skills in the field of ship salvage and rescue towing. It is sometimes said that "Ship Masters are trained in the business of keeping vessels off the rocks; salvors in the business of getting vessels off the rocks." There is a great deal of truth in this saying and one will be wise to keep it in mind. Few ship masters have any experience at all in ship salvaging techniques.

"Salvors" in the broad sense of the term may include surveyors (though not all surveyors are salvage-experienced) from U.S. Salvage Association or the Salvage Association of London; specialist salvage consultants who may be dispatched by underwriters or owners to survey the situation; employees of the salvage company with whom the Ship's Master, the owners or underwriters or the Coast Guard have contracted to attend to the situation at hand; or to representatives of the Navy's Supervisor of Salvage or from the Fleet's Salvage Forces.

Two general types of information may be available from salvors-- that which can best be described as "operational" or "special seamanship"; and that which is primarily "special engineering" dealing with damaged stability, residual hull strength, ground reaction and the like.

In general, two types of specialists are needed to provide the full spectrum of this information: the Salvage Master and the Salvage Engineer. A special caution is appropriate towards evaluating these information sources: just as the Ship's Master handles "normal seamanship," the Salvage Master handles "distressed seamanship." Likewise, the average naval architect/ naval engineer is seldom expert or pre-trained to handle damaged or distressed ship stability and structural matters; this is the realm of the Salvage Engineer. Rarely is the same person to be relied on for expert advice in both these general areas.

While it is a truism that no two salvage incidents are alike and that the usual salvage operation is ad hoc in nature, it will

nonetheless in many cases be found that salvors have previously had to cope with similar exercises. The experience factors which they bring to the effort can be vital in either saving the distressed vessel or in mitigating pollution. Of particular note is the growing trend for tanker companies, and particularly owners/operators of vessels which carry hazardous cargoes (such as LNG; anhydrous ammonia, etc.), to have prepared special contingency plans wherein actual salvage situations have been postulated and pre-gamed. These contingency plans often include salvors who have been a part of the pre-gaming and, hence, are well "up on the step" as regards working out the problems--both operational and engineering--involved in the particular distress situation; that is, in making the salvage/pollution control exercise less ad hoc than it might otherwise have to be.

Salvors may be able to supply information such as the following:

- Availability of salvage tugs, mooring support craft, lighters or other floating plant which may be required to commence the salvage job.
- Availability of fire fighting personnel and equipment, as well as pollution control equipment and people.
- Local weather and sea conditions including tide, current anomalies and sea bottom conditions as they relate to scouring and to anchor holding.
- Evaluation of time factors to bring into play salvage forces for lightening, extraction from strand or other "real-time" evolutions.
- Analysis of damage state of ship and evaluations of time-criticality of the situation as it may relate to jettisoning cargo; placing out moorings, ballasting down, emergency use of engines, etc.
- Emergency Damage Control measures.
- Analysis of hull girder strength and likelihood of ship breaking up.
- Various options as to means to salvage -- along with forces required, engineering needed, and chances of success.
- Safety aspects of the situation.

Equipment Owners/Operators: Owners/operators of response equipment can provide useful information in the contingency planning stages and during operations. Information from these sources can usually be obtained in the areas of:

- . Equipment (pumps, salvage gear, etc.)
 - . Capacities and limitations
 - . Size/weight
 - . Handling provisions (helicopter deployable, etc.)
 - . Availability (location, quantity on hand, time for delivery)
 - . Deployment and setup recommendations
 - . Operation (on contract)
 - . Leasing requirements
- . Floating equipment
 - . Types of vessels (workboats, barges, tugs, cranes, etc.)
 - . Size/capacity (including speed, duration at sea)
 - . Availability (location, number on hand, time to arrive on site)
 - . Chartering requirements

In addition to direct contacts with owners/operators, information on equipment availability can be obtained through SKIM (Spill Cleanup Equipment Inventory System). SKIM is a computer based inventory of equipment available for pollution response in the U. S. The inventory includes public equipment (USCG, USN, etc.) and equipment maintained by contractors, cooperatives, and private companies. Information may be extracted from the inventory on the basis of location, equipment type or equipment operator. The system is currently being accessed and updated by Coast Guard Marine Safety Offices using dataphone terminals. Instructions for utilizing SKIM may be found in the Marine Safety Manual, (CG-495).

Typical equipment owners/operators include such organizations as:

- . Coast Guard Strike Teams: Atlantic, Gulf, and Pacific

Coast teams are available for large or unusual casualty response operations. Principal response tools are the ADAPTS pumping system, OWOCS high-seas barrier, and the skimming barrier. However, many other equipment items are available, and the Strike Team personnel are highly trained in their use. Most equipment is packaged and maintained for quick response via tractor-trailer, C-130 aircraft and helicopter.

U. S. Navy Supervisor of Salvage (SUPSALV): SUPSALV maintains two major equipment bases in the continental U. S. at Cheatham Annex, Virginia, and Stockton, California. Considerable quantities of oil spill control equipment are stored at both bases, principally inflatable booms (Goodyear) and Marco Class V skimmers. Many other equipment items are included, also, such as pumping equipment, heaters (Clayton boilers), mooring equipment, beach gear, and ship fenders. SUPSALV policy is to send out supervisory personnel with their oil spill control equipment, but most of the operating labor must be provided by the user. Most of the equipment is maintained in a ready-for-issue (RFI) state, but response time can be expected to be greater than that of the Strike Teams. Much equipment can be airlifted but this involves more preparation than if truck transport is used.

In addition to the equipment pools, SUPSALV maintains contracts with commercial organizations to conduct oil spill cleanup services and salvage operations. These organizations operate their own as well as Navy assets. These assets include salvage vessels, which could be useful in many pollution response operations. SUPSALV can be contacted at NAVSEA headquarters in Washington, D.C.

Various Navy commands: Various shoreside and fleet commands have specific oil spill cleanup responsibilities, which are generally implemented through contract organizations or other groups. Much of the equipment utilized is provided by the Naval Facilities Engineering Command (NAVFAC). Primarily, this equipment is designed for harbor or protected water operation.

In addition, various types of Navy vessels, such as tugs, and salvage and rescue ships, would be useful in assisting in offshore response operations. Certain tankships could also be used for off-loading or for recovered oil storage. Typical vessel characteristics are listed in Section 5.5.

- . Cleanup contractors: Cleanup contractors in the local areas usually have equipment to deal with only small protected-water spills (harbor boom, small skimmers, vacuum trucks, sorbents, etc.). However, they do have access to labor pools that can be utilized in many cases. Larger contractors may have specialized equipment that can be valuable in certain cases. Contractual arrangements, using the Coast Guard Basic Ordering Agreement (BOA), should be made in advance to ensure quick response when necessary.
- . Equipment dealers and manufacturers: Dealers and/or manufacturers may have equipment available that can be purchased quickly, but this is unlikely except for small items (small skimmers, harbor boom, etc.) suitable only for harbor use. These facilities can be monitored for equipment availability, however.
- . Spill cleanup co-ops: Several co-ops have a considerable inventory of oil spill cleanup equipment suitable for open water and in-shore use. Maintenance and operation are performed by contractors, so that a trained cadre is available to operate the equipment. In many cases the equipment on-hand is designed for use in a specific area and is not easily transportable to distant locations on a fast-response basis (large dedicated skimmers, large off-shore boom systems, barges, etc.).
- . Transportation companies: In certain areas transportation and offshore service companies can provide tugs, barges, tankships, workboats, and other vessels that could be useful in pollution response operations. Various applications of these vessels are discussed in other sections. The management of these companies can provide recommendations on the utilization of their vessels, and on limitations and other operational characteristics.

3.0 PREVENTION OF OIL SPILLAGE FROM VESSEL CASUALTIES

Various types of casualties fit into this category, as outlined below:

1. Grounding:
 - a. sand
 - b. mud
 - c. coral
 - d. rocks
 - e. impalement
 - (1) rocks
 - (2) wreckage or other structure
2. Collision:
 - a. between ships
 - b. with structure (bridge, nav. aid, piers, icebergs)
3. Hull rupture:
 - a. from external cause (other than grounding or collision)
 - b. from internal cause (structural failure - hogging, sagging, corrosion, fatigue, etc.)
4. Fire
5. Explosion
6. Sinking
7. Loss of command (steering)
8. Flooding
9. Breakup in heavy seas

This guide will concentrate on the grounding cases, as groundings occur frequently and involve most of the response options that the other casualty types would. These cases usually involve the interaction of salvage personnel, pollution abatement personnel, and the ship's owners/underwriters/operator. Although the Coast Guard will be active in following any casualty situation involving potential pollution, in offshore grounding cases, especially in heavy weather, there is a good probability of having to assume command of the overall operation.

Although this Guide is oriented toward oil tanker casualties, the pollution abatement approaches will generally apply to any other large ship casualty whose fuel oil, lube oil, and day tank contents could constitute a major oil spill threat.

Frequently, the OSC will first become involved in the casualty situation through a search and rescue (SAR) mission. From this vantage point, monitoring and assessment of the situation can begin. In many cases, however, progression of a casualty incident to the SAR stage before the OSC becomes involved indicates that it is probably too late to perform certain time-critical operations, such as jettisoning, which could possibly save the ship and the bulk of the cargo. Assessment and surveillance should begin as soon as possible after any casualty occurs in which pollution could be a threat.

3.1 Response Guidelines for Tanker Casualties

In the event of a ship casualty, the pollution danger can be classified in two ways:

1. Ship is damaged and spillage is occurring
2. Ship is in danger of (additional) damage that can cause spillage

In the first case the obvious solution is to stop any further spillage by one of the following approaches:

1. Plug the leak (difficult-to-impossible to accomplish in time to prevent maximum leakage from the tank unless the leak is very small) ⁽⁹⁾
2. Remove the cargo from the leaking tank (store in other tanks or off-load)

In the latter case, where spillage is not occurring but may be imminent, several approaches can be taken, depending on the probability of additional damage occurring and on the magnitude of damage anticipated. The extreme case of damage would be a breakup of the ship, which can occur in heavy weather and cause spillage of the entire cargo.

Each response operation can be characterized by the length of time it takes to perform the operation, as influenced by the effects of the weather and sea conditions. Unfortunately, worsening weather and sea conditions can also shorten the time that the casualty will remain intact without further damage. Figure 3.1 indicates how these time factors interact to determine whether a particular response approach is viable or not.

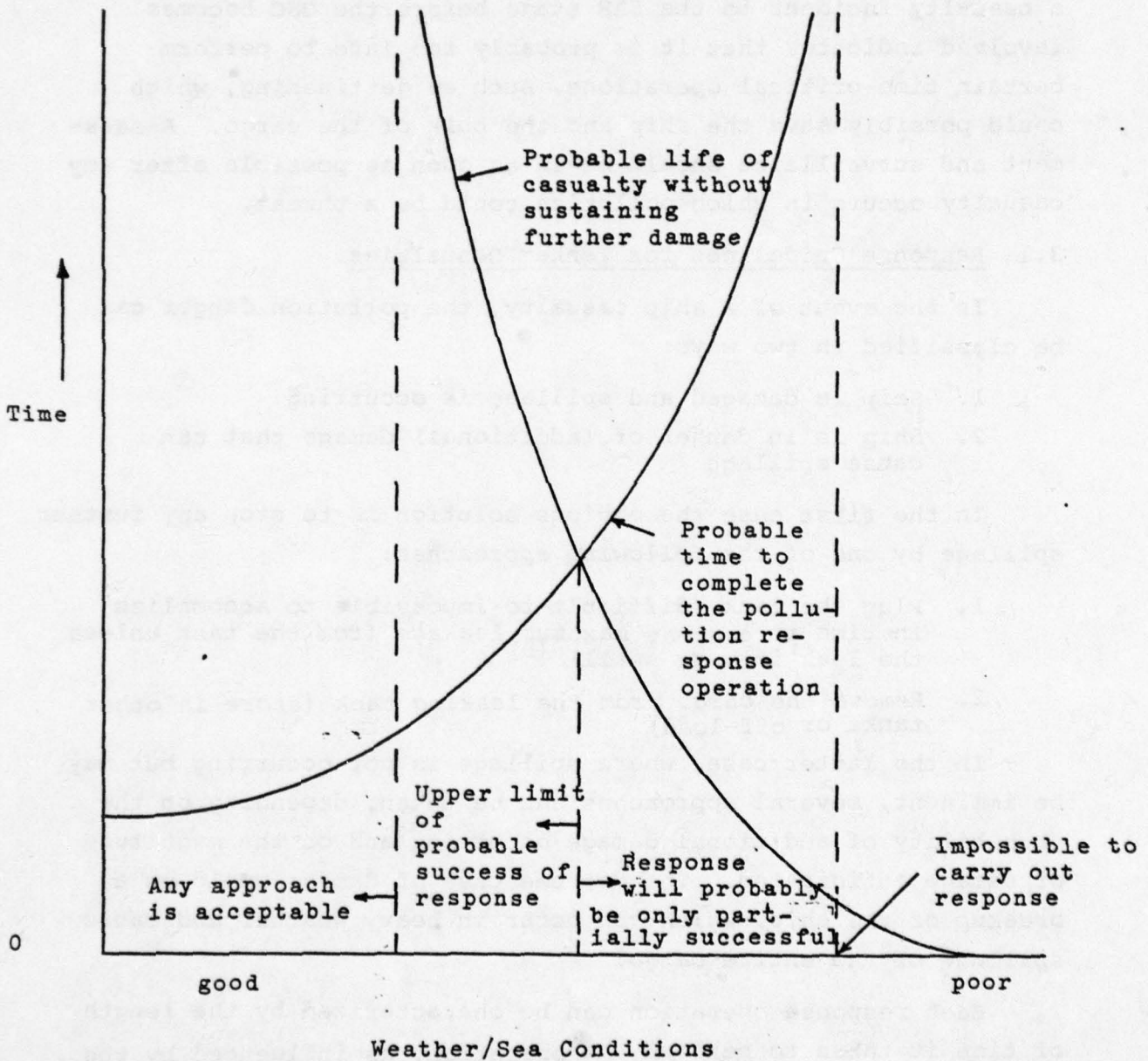

FIGURE 3.1 TIME EFFECTS ON CASUALTY LIFE AND RESPONSE APPROACH

The most difficult factor to estimate in Figure 3.1 is the life of the casualty as a function of the weather. This will depend on the type of casualty, the amount of damage already sustained, the characteristics of the vessel, and certain environmental conditions (for example, sea bottom characteristics in the case of a grounding). At best, the subjective opinion of a salvor, who has examined the vessel and the information collected during the initial assessment, may provide the only realistic estimate of the remaining life as a function of the anticipated weather.

One problem with the effect of weather and sea conditions on the casualty life is that the effects can be cumulative; i.e. a series of storms can weaken the structure in successive increments resulting in eventual break-up, whereas little weakening is likely to occur during the calm periods between the storms. The same holds true for the response time, where the rate of task accomplishment may be zero during storms and proceed at maximum rate during calm. Figure 3.2 shows a simple example of these points. In this case, the vessel breaks up before the response is finished; however, 80% of the work is accomplished, resulting in only 20% cargo loss.

The conclusions that can be drawn from the above discussion are that:

1. Where extended periods of bad weather are forecast, the most rapid response method available should probably be utilized.
2. If relatively good weather is anticipated almost any response approach can be utilized successfully, depending on the casualty type, and elimination of all pollution should be attempted.

3.2 Response Alternatives

The response alternatives can take several general approaches as outlined below:

1. Save the ship first, thereby containing the cargo
2. Save the cargo first and deal with the empty ship later

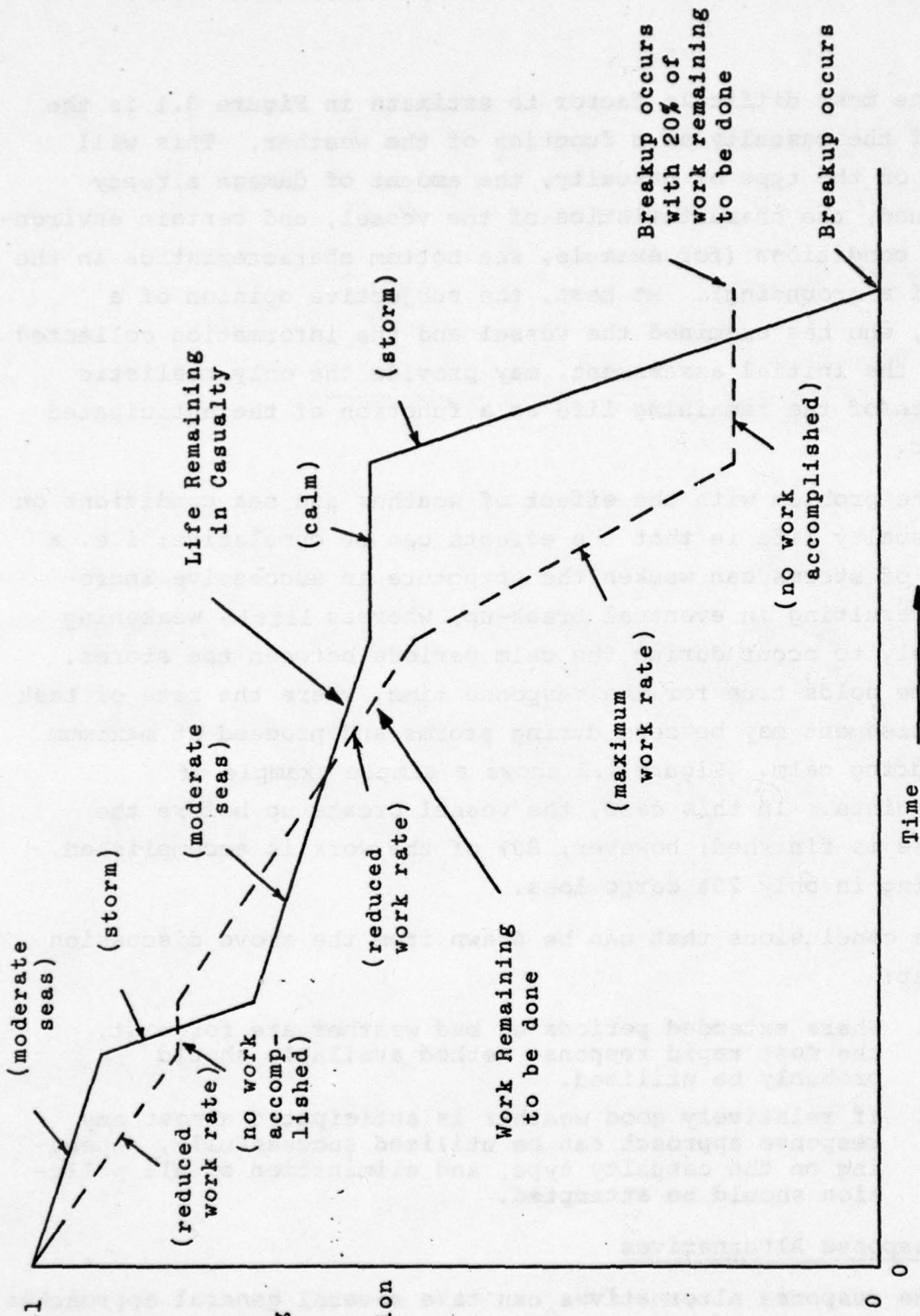

Fraction of
Life Remaining
and
Fraction of
Response Operation
Remaining to
be Done

FIGURE 3.2 EXAMPLE OF CUMULATIVE EFFECTS OF RESPONSE TIME AND CASUALTY LIFE

3. Destroy the cargo while it is still on the ship, and deal with the ship later.
4. Destroy the ship and cargo.

Depending on the casualty type, one or more of these approaches could be pursued. For an all around best approach, the first alternative is preferred, as both the vessel and cargo are saved, and minimum handling of the cargo is required. The second alternative can have the same end result as the first (both cargo and ship saved), and it may be the only viable alternative in many cases (groundings). The third alternative only attempts to minimize pollution, probably destroying the vessel in the process (burning), and is only recommended as a last resort. The fourth alternative infers sinking the ship in deep water with cargo aboard (probably burning) and can only be done with a floating casualty. This action is usually the result of not being able to do anything else other than towing the casualty away from sensitive areas where its ultimate break-up will cause the least amount of environmental harm. In general, as much cargo off-loading as can be safely performed should be done before a ship is sunk. By closing off openings on the cargo and fuel tanks the risk of subsequent leakage may be minimized; however, this could be an extremely hazardous undertaking on a burning ship or on one in imminent danger of sinking.

Specific techniques applicable to each of the first three general approaches are listed below:

1. Save the ship
 - a. Strandings
 - Shift cargo to empty tanks and pull the ship off the strand
 - Portable pumps
 - Ships pumps (if operable)
 - Pump part of cargo to flaring burner (portable pumps), and pull off strand

- Pump part of cargo to another vessel and pull the ship off the strand
 - Portable pumps
 - Ship's pumps (if operable)
- Jettison part of cargo
- Gel the cargo in vulnerable tanks
- b. Collision, hull rupture, explosion
 - Shift cargo from damaged tanks to sound tanks
 - Portable pumps
 - Ship's pumps (if operable)
 - Pump part of the cargo to other vessels
 - Portable pumps
 - Ship's pumps (if operable)
 - Gel the cargo in vulnerable tanks
- 2. Save the cargo first, then deal with the vessel
 - a. Off-load all cargo to barges, tankships, portable containers
 - Ship's pumps (if operable)
 - Portable pumps
- 3. Destroy the remaining cargo
 - a. Bomb the vessel and burn the cargo in-situ
 - b. Use explosives to open up the vessel and burn the cargo in-situ

Note that the principal difference between approach 1 and 2 as far as off-loading is concerned is that all of the cargo is removed in approach 2, but only part of the cargo (enough to permit towing the ship) is removed in approach 1. Approach 2 would apply more to cases in which the ship is badly damaged and/or a major salvage job would be required before she could be moved. In general, if rough weather is anticipated, it is best to refloat the vessel as soon as possible and then tow it to calm water for further off-loading. Many ports and harbors would be adverse to permitting a damaged but laden tanker to enter their jurisdictions, and the problem of finding a safe haven can be a problem. This problem should be addressed during contingency planning.

In any particular situation, some of the above techniques may not be feasible, because the time required to perform them in the anticipated weather conditions may be greater than the life expectancy of the casualty.

A summary of the estimated sea state working ranges or limits for the state-of-the-art response approaches discussed later appears in Table 3.1. The potential for success of each approach is noted as good, fair, or poor depending on the sea state existing during operations. These ratings were arrived at by engineering judgments and are at best subjective.

3.3 Response System Descriptions

In the following sections, descriptions of the approaches are given, showing Time Plan diagrams that may be used to estimate the response time requirements for specific areas, and providing decision diagrams for deciding if the approach is feasible. Of the feasible approaches, the ones that in the opinion of the OSC, best meet the priorities below should be considered for implementation:

1. Low pollution risk
2. Low risk to personnel and response equipment
3. Fast response time
4. Low risk to casualty vessel
5. Low overall cost (including hull and cargo value and beach cleanup costs)

Details of specific equipment items and support systems are presented in Section 5.

TABLE 3.1 SEA STATE OPERATIONAL LIMITS FOR
RESPONSE APPROACHES

RESPONSE APPROACHES	SEA STATE					
	1	2	3	4	5	6
Jettison-ship's pump portable pumps	good good	good good	good good	good fair	good fair	good poor
Stabilize the vessel with seawater ballast and moorings for delayed off-loading	good	good	good	good	fair	poor- fair
Stabilize the vessel with moorings for off-loading in existing conditions	good	good	good	good	fair- good	poor- fair
Off-load cargo without stabilization	good	fair- good	poor- fair			
Burn cargo in tank by bombing	good	fair	poor- fair			
Burn cargo in tank by planting explosives	good	fair	poor- fair			
Cut up the vessel for towing	fair	poor				

3.3.1

Approach: Off-load Cargo to a Receiving Vessel

A. Applications

1. Change trim or list and lighten vessel to remove from strand.
2. Remove cargo from holed or damaged tanks, or from tanks where failure is imminent.

B. Description of Approach

1. The following components are required:
 - a. Pumping system: If the ship's pumps are operable, and piping or any on-board hoses will permit, this equipment should be utilized. Otherwise, ADAPTS or similar high-capacity portable pumps will be required (see Section 5.1).
 - b. Salvage vessel: In the case of a grounding, one or more salvage vessels should be available to take the vessel in tow upon freeing. These vessels may also be used to assist in the actual freeing operation if beach gear is employed. Salvors should be consulted for utilization of beach gear and salvage vessels.
 - c. Receiving (lightening) vessels for off-loaded oil: A variety of receiving vessels can be utilized, ranging in size from barges or tankships to flexible (rubber or plastic) towable containers (see Section 5.4). The size should be compatible with the amount of cargo to be off-loaded, to minimize the number of transfer operations required. A small draft may be required for grounding cases. Extra hoses may be required, also.
 - d. Fenders to place between the casualty and the receiving vessel: Either foam-filled or pneumatic rubber floating fenders can be used. Foam-filled fenders offer the advantage that they will not lose their energy absorption capacity if punctured by a damaged casualty. Usually three or more fenders are required. The size should be selected according to the size of the vessel involved.

2. In a grounding case, determine the ground reaction, the point of stranding, the change in trim and displacement required to reduce the ground reaction sufficiently to free the ship, the amount of cargo to be shifted, and and from where the cargo should be removed. See Appendix D for typical grounding calculations and examples. The input data can be obtained from the casualty assessment step.
3. Determine the number of pumping systems and receivers required. Procure the necessary equipment.
4. Bring receiving vessel and fenders alongside and secure.
5. Prepare salvage ships with beach gear for pulling (if necessary) and initial towing (grounding situation). The vessel should be taken in tow when propulsion or steering systems are inoperable in cases other than groundings.
6. Off-load the cargo. Time the operation so that the ship can be pulled off at high tide in grounding situations.

C. Variations on Basic Approach

1. In a grounding situation, to minimize working of the hull on the strand while the ship is light, the oil off-loading can be accompanied by equivalent ballasting with sea water to keep the ship heavy. After the oil is safely removed, the ballast water can then be pumped rapidly overboard using all available pumping capacity to free the ship at the proper time (high tide). This approach is especially recommended in rough seas or when all of the cargo is to be off-loaded.
2. If a grounding is not too severe, or if only one or two tanks are leaking in a non-grounding situation, it may be possible to merely shift cargo within the vessel, utilizing unused tanks, ballast tanks, ullage space, or other available spaces. Again, either ship's pumps or portable pumps may be used. Pillow tanks laid on deck may also be used if available, but vessel stability is decreased by this approach. The general calculations for changing trim by shifting cargo are given in Appendix D.
3. Flaring (burning) of cargo: This technique is for all practical purposes, unavailable at this time, although the Coast Guard does have a portable flaring burner system under development. In principle, the cargo would be pumped to the burner mounted on the casualty's deck, rather than to an off-loading vessel. The advantages are that no oil spill pollution would be incurred, while at the same time the need for a receiving vessel for off-loading would be avoided. However, the time requirement for on-board flaring could be much greater than for off-loading. For example, a 100,000-DWT tanker has

a pumping system capable of discharging on the order of 50,000 gpm, while a state-of-the-art flaring system (of the type used for testing offshore oil wells) has a maximum capacity of less than 500 gpm -- a factor of 100 difference. Even a single ADAPTS pump has a capacity three times that of a flaring burner. In addition to the problem of slow burning rates, a considerable mobilization and setup time would be required, with bad weather compounding the difficulties. After emergency flaring systems become available, their use will probably be limited to small tankships and barges. Consideration should be given to flaring cargo when a suitable lightening vessel is not available, particularly if only one or two leaking tanks are to be off-loaded.

4. Pressurizing a breached tank with air is a technique commonly used for displacing water to lighten a vessel during salvage operations. The deck openings must be sealed, and the allowable pressure that can be applied to the tank must be known. If cargo is displaced, the technique becomes a form of jettisoning. Air pressure can also be used for off-loading cargo through the ship's piping if the tanks are sound. However, the pressure required to force the oil from even a nearly full tank up to the deck piping could endanger the structural integrity of the tank (maximum pressure on the order of 4 to 6 psig). Pressure drop in the transfer piping and hoses requires additional pressure in the tank, thus limiting the applicability of the technique to a relatively small amount and rate of offloading. Portable air compressors are common, and the smaller sizes could be transported by helicopter to the casualty.
5. The use of water pumped into the tank to displace oil is similar to the technique discussed in 4. above. This approach suffers from the same over-pressure problem, although in this case the pressure on the tank top does not change as the oil is displaced. However, a tank top opening into the piping system is required, which is normally not available on tankers, and any unsecured openings will leak oil and not air. Again, this will only work in a sound tank.

D. Advantages

1. Lightens a ship or stops leakage with no loss of cargo.
2. If off-loading is complete, then the pollution problem is minimized no matter what happens to the ship (breakup, etc.).

E. Disadvantages

1. Process can be slow if the tanker is large, and if:
 - . Ship's pumps are inoperable (portable pumps must be used exclusively).
 - . The grounding is hard.
 - . The ship is impaled through the bottom (rock pinnacle, old wreck, etc.).
 - . The weather is bad in Sea State 3 and above.
2. It can be difficult and hazardous for a receiving vessel to approach alongside and moor if the water is shallow and if the sea state is high.
3. Availability of suitable off-loading vessels may be limited, and obtaining such vessels can cause delays.
4. Handling of hoses between vessels can be difficult, particularly if:
 - . Hoses are heavy (ships cargo hoses) and power on the casualty is lost, limiting lifting capability.
 - . Hoses have to be provided with flotation, or if floating hoses are used.
 - . Un-manned receivers, such as Dracones, are used in higher sea states.

F. Special Problems/Techniques for Extreme Weather

1. Mooring receiving vessel alongside stranded tanker:

Rough seas can make conventional fendering or anchoring of a lightering vessel an unsafe operation. A dynamic station-keeping system would be desirable but no typical lightering vessels have this capability, and the shallow water in the vicinity of a stranded vessel could make this approach infeasible.

One system that is presently in use for securing off-shore supply boats to drilling rigs uses two synthetic mooring lines to tie the vessels together. Power is then applied by the supply boat to maintain tension in the lines. The synthetic ropes have significant stretch and act as springs to absorb

the dynamic loads. The shock to the platform and vessel is significantly reduced and extreme weather transfer of cargo can be carried out. These systems are limited to 12-foot seas. Figure 3.3 shows how this system might be applied to an off-loading operation using a receiving barge and tug. Separations of 50-100 feet can probably be safely maintained. Mooring line sizes should be selected on the basis of tug/barge size and sea conditions. Provisions for supplying and handling heavy and bulky floating hoses must be considered in planning operations.

2. Stabilizing a grounding casualty:

In a grounding situation where a large amount of cargo must be removed and a considerable length of time is involved, consider stabilizing the vessel during the off-loading process. The purpose is to prevent movement of the ship due to wind, current, tide and wave forces, thus minimizing further damage to the hull until an off-loading or salvage operation can be completed.

Two techniques may be useful:

- a. Fill all available ullage and unused space in a stranded vessel with seawater to increase the ground reaction, by seating the vessel firmly on the strand.
- b. Provide additional moorings on the casualty vessel.

Special considerations for stabilizing:

- . Consider all spaces for flooding - ballast tanks, double bottoms, even the engine room (if inoperable).
- . Bottom beneath ship must be fairly smooth and not steeply sloped.
- . Ship should be oriented in direction of least natural force when ballasting or mooring.
- . Casualty's anchors must be placed by another vessel because they are located at the bow where the grounding usually occurs.

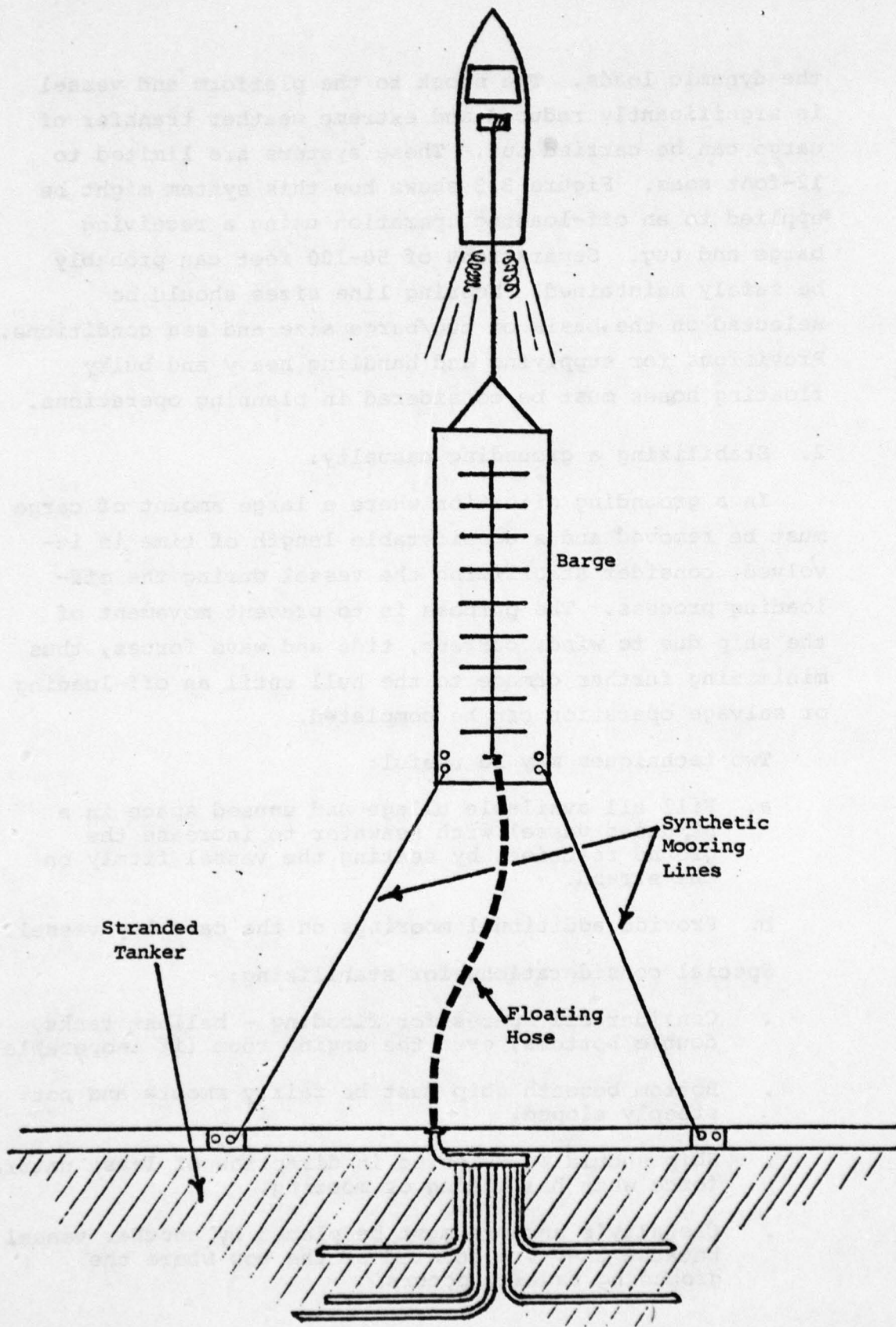

FIGURE 3.3 MOORING SYSTEM FOR OFF-LOADING STRANDED TANKER IN HIGHER SEA STATES

- Stern moorings have to be procured, deployed by a separate vessel, and tensioned from the casualty deck. Special aircraft-deployed, self-powered winches may be required for tensioning.
- The natural forces (wind, current, waves) must be estimated to determine the necessary ballasting and moorings.
- Ideal ballasting pumps are of the low head, high volume, low weight, centrifugal type. Agricultural irrigation pumps (well-point) are well suited, as are salvage water pumps (ADAPTS may be too slow for a large vessel).
- Deck wash may increase as operations proceed and the freeboard is reduced.

G. Planning Considerations

1. Time Plans: Figure 3.4 shows an example Time Plan for the case where the cargo from a stranded tanker is to be offloaded into a barge moored for rough-sea conditions (Figure 3.3). Also, portable pumping systems are used, which are delivered by helicopter. In this example, obtaining a barge is shown to be a critical operation.

Figure 3.4 also shows an example Time Plan for the situation where a grounded tanker is stabilized by ballasting, using portable sea water pumping systems. This operation could be conducted in parallel with the off-loading operation.

2. Decision Process: Figures 3.5 and 3.6 show the general decision process to determine if off-loading and ballasting/stabilizing are viable techniques for a given situation. Similar considerations would be made for other casualty situations besides groundings.
3. Planning Checklist: See Table 3.2.

FIGURE 3.4 TIME PLANS FOR CARGO OFF-LOADING AND SHIP BALLASTING

Vertical column of text on the right edge of the page, possibly a page number or index.

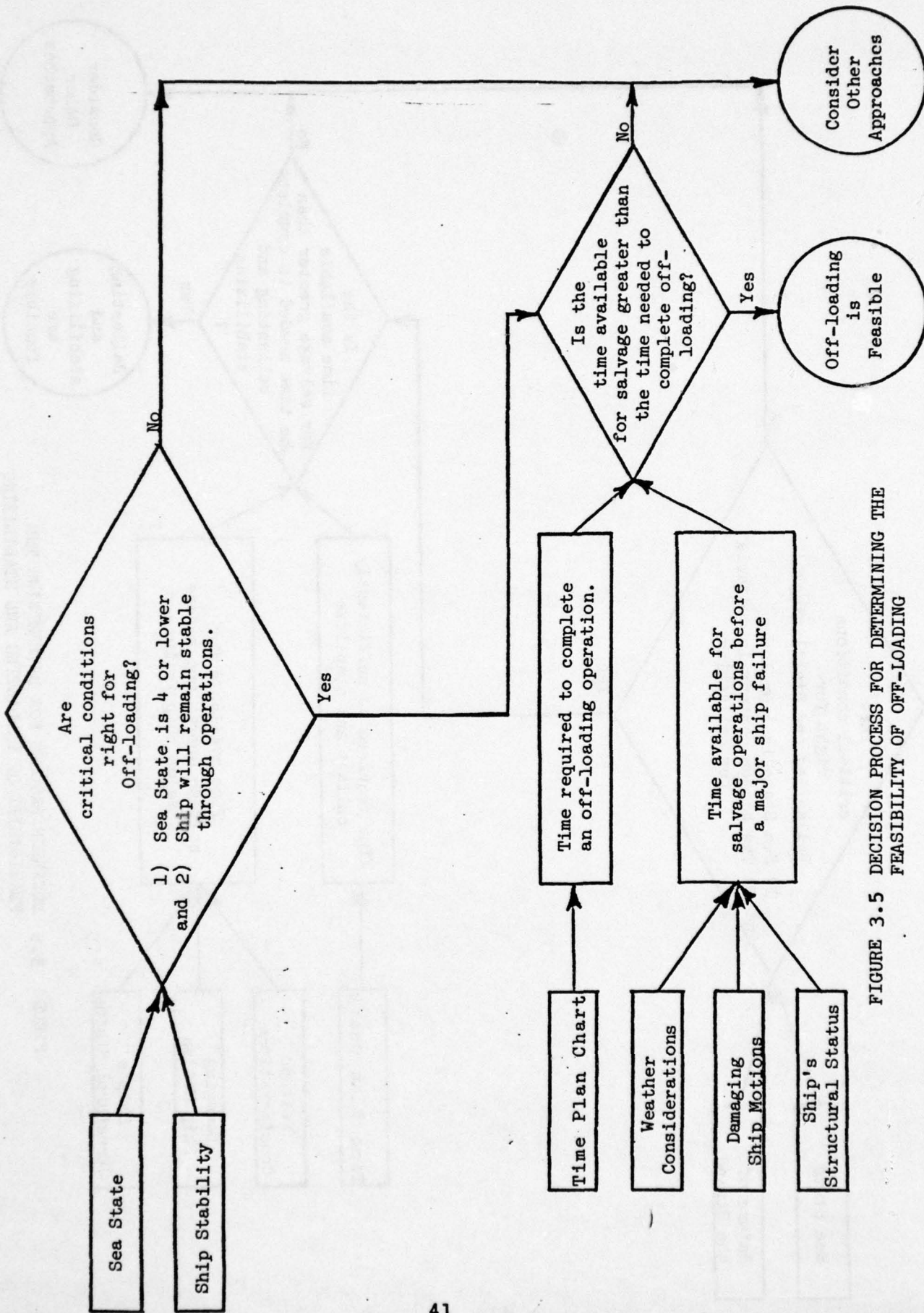

FIGURE 3.5 DECISION PROCESS FOR DETERMINING THE FEASIBILITY OF OFF-LOADING

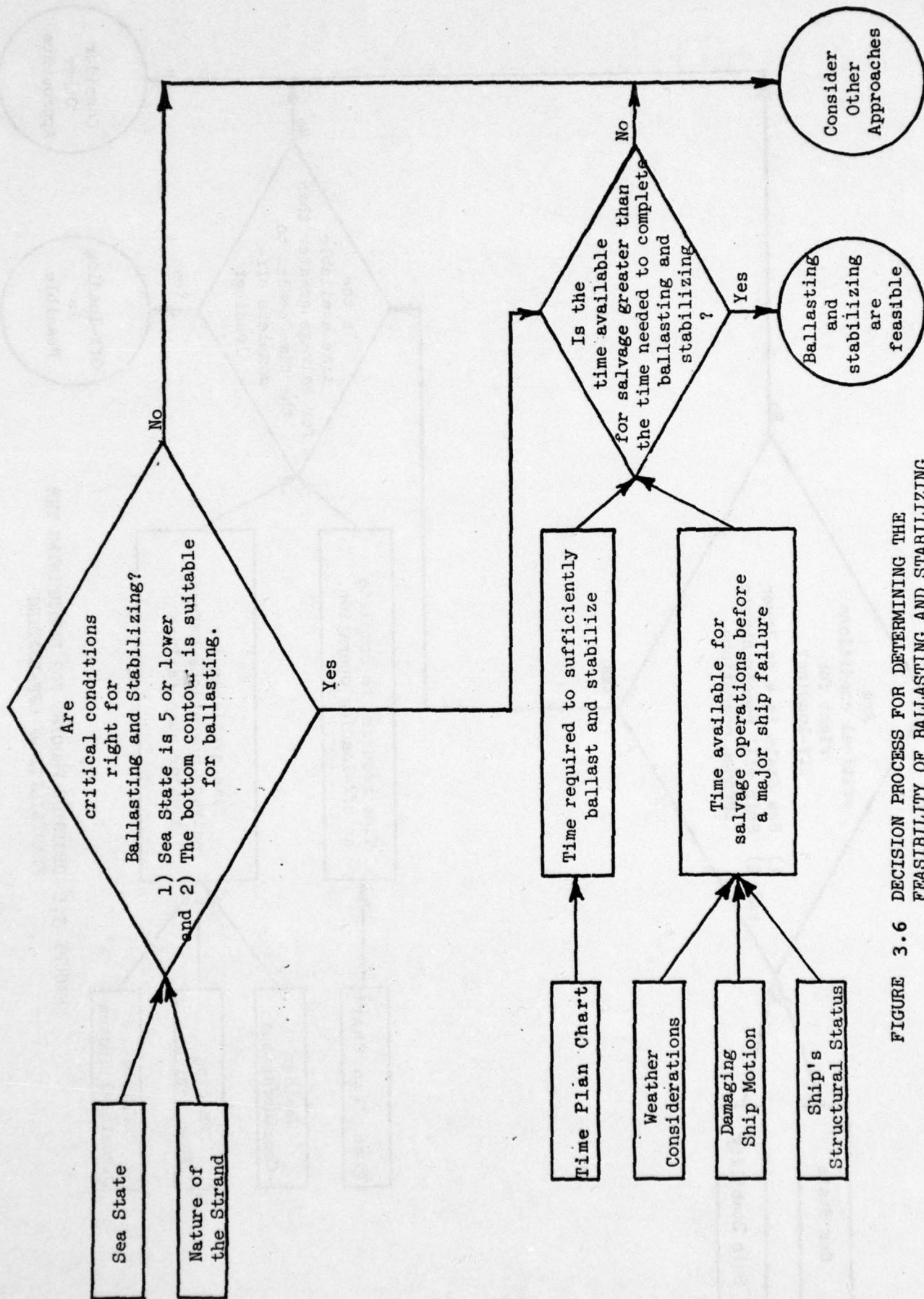

FIGURE 3.6 DECISION PROCESS FOR DETERMINING THE FEASIBILITY OF BALLASTING AND STABILIZING

TABLE 3.2

OFF-LOADING -- PLANNING CHECKLIST

1. Assessment completed (See Section 2.4)?
Special considerations in assessment:
 - a. Damaged or holed tanks?
 - b. Impalement?
 - c. Water depth around casualty?
 - d. Weather forecasts?
 - e. Operability of ship's pumping system?
 - f. Trim and list? Stability?
 - g. Oil properties and temperature?
2. Estimates made for:
 - a. Ground reaction (Appendix D)?
 - b. Location of grounding (on hull -- Appendix D)?
 - c. Quantities of oil to be removed, and from which tanks (Appendix D)?
 - d. Stability predictions (Appendix C)?
 - e. Structural integrity?
 - f. Desired pumping rate?
 - g. Towing power requirements (Appendix G)?
3. Information available on:
 - a. Ship's pumping/piping system:
 - . can they be used?
 - . capacities?
 - . adequate hoses available?
 - b. Steering/propulsion system:
 - . force that can be developed in backing the ship off the strand.
 - . additional pulling required by beach gear/salvage tug.
 - c. Emergency pumping or air-pressurizing systems:
 - . number available and location?
 - . response times (delivery systems, personnel)?
 - . availability of extra or special hoses (floating)?
 - . can they be used for pumping ballast water?

- d. Receiving vessels (with tugs, if necessary):
 - . type, sizes available?
 - . response times?
 - . unloading facilities (on-shore)?
 - . mooring methods and equipment?
 - . availability of fenders?
 - . chartering procedures?
 - e. Towing/salvage vessels for standby or pulling:
 - . type, sizes, available?
 - . response times?
 - . anchor handling and mooring capabilities?
 - . chartering procedures?
4. Selections made for:
- a. Pumping systems and hoses?
 - b. Receiving vessels and support craft?
 - c. Fenders?
 - d. Special moorings?
 - e. Standby tugs/salvage vessels?
 - . towing gear?
5. Plans made for:
- a. Casualty stabilizing for rough weather?
 - b. Receiver mooring to casualty?
 - . calm water (fendering approach)
 - . rough water (synthetic-line-standoff approach)
 - c. Mobilization and delivery of pumping equipment?
 - d. Pumping plan?
 - e. Pulling casualty off a strand?
 - f. Casualty towing and other tug/salvage vessel operation?
 - . setting casualty moorings
 - . employment of beach gear
 - g. Handling of off-loaded cargo?
 - h. Replacing off-loaded cargo with sea water?
 - i. Cargo shifting within the vessel confines?
 - j. Personnel protection?
 - k. Receiving the casualty vessel at a port?

6. Contingency plans prepared for:

- a. Emergency stabilizing?
- b. Equipment/personnel removal from the casualty?
- c. Oil spill control in event of breakup?
- d. Scuttling vessel if it cannot be towed?
- e. Bombing and burning (as a last resort)?
- f. Gelling certain cargo tanks before towing?

7. Safety considerations (See Appendix A)?

3.3.2

Approach: Jettison Part of Cargo

A. Applications

1. Immediate change of trim and lightening to remove from stranding during bad weather.
2. Final lightening of vessel during off-loading process, when bad weather is imminent and receiving vessel cannot remain alongside.

B. Description of Approach

1. The following components are required:
 - a. Ship's cargo pumps: These are an integral part of the ship's machinery, but all piping, power, and control systems must be in working order before the pumps can be used. Short hose lengths or ducting may be desirable to keep oil off the deck during discharge.
 - b. Tug/salvage vessel: One or more tugs or salvage vessels should be available to take the vessel in tow upon freeing until steerageway is attained. These vessels may also be used to assist in the actual freeing operation if beach gear is employed. Salvors should be consulted for utilization of beach gear and salvage vessels.
 - c. Spill control and cleanup equipment: Although it is not absolutely necessary to have this equipment operating at the beginning of the jettisoning process, it should be mobilized and deployed as soon as possible. The size and type of equipment needed will depend on several conditions. (See Section 4 for details.) Barrier (boom) systems may be preferred, as jettisoning will probably be performed at a rate much higher than any skimmer is capable of handling continuously.
2. Determine ground reaction, the point of stranding, and the change in trim/displacement required to reduce the ground reaction sufficiently to back off the ship using ship's power. (See Appendix D for calculations.)
3. Determine the amount of cargo to be jettisoned and from which tanks.

Arrange for the tug to stand by and assist the vessel after backing off the strand.
4. Arrange to have spill containment/recovery equipment brought to the scene to control the jettisoned oil.
5. Jettison the cargo using the high-volume ship's pumps, so that the vessel will back off the strand at high tide.
6. Clean up the resulting oil slick.

C. Variations on Approach

1. Although ship's pumps provide the highest jettisoning rate (on the order of 10 percent of the cargo per hour), it is possible to use portable pumping systems. The problem with this approach is that if the rate is too slow the strand may become worse in time, and only unnecessary pollution will result from jettisoning.
2. Pressurizing certain tanks with air can force cargo out through the piping system and into the water. Also, if a tank is breached, air pressure in the tank will force water and cargo out the hole, thereby increasing the buoyancy. In either case the deck openings must be sealed, and the allowable pressure on the tank top must be known. Portable air compressors are common and many sizes can be easily transported to the casualty by helicopter.

D. Advantages

1. Lightens a vessel and removes it from the strand potentially faster than any other method. Assessment, calculations, and tug procurement are still required, however.
2. Saves the bulk of the cargo from causing pollution, at the expense of a relatively smaller amount of pollution.
3. Provides the best chance of maintaining the hull and ship systems intact.
4. Could be accomplished (with adequate tug assistance) in sea conditions up to Sea State 5 or 6.

E. Disadvantages

1. Causes deliberate pollution
2. If performed without the aid of an adequate tug in bad weather, the vessel can reground before it can maintain steerageway.
3. The decision to jettison, even though successful, leaves the OSC open for criticism from those who may feel that the salvage job could probably have been performed without causing any pollution.
4. If the vessel is impaled, and this is not detected during the assessment, much more cargo may have to be jettisoned than originally anticipated. This could lead to far more pollution than estimated, with the possibility of not being able to free the vessel after all.

F. Special Problems/Techniques for Extreme Weather

The technique of jettisoning is in itself a special technique for extreme weather. If bad weather is imminent or exists, jettisoning may be the only technique that will save the bulk of the cargo. However, the worse the weather the more important it is to have an adequate tug or tugs standing by to prevent further grounding as the vessel lightens. When in doubt, stabilizing by ballasting or moorings can be considered (See Off-Loading).

G. Planning Considerations

1. Time Plans: A Time Plan diagram for jettisoning can be prepared similar to the off-loading case, although a much simpler diagram would result. Contingency plans for stabilizing would require a diagram similar to Figure 3.4. One of the skimming/dispersing Time Plans should be utilized for planning cleanup operations.
2. Decision Process: Figure 3.7 shows a general decision diagram for determining the feasibility of jettisoning. Several key steps are involved. The final decision should be made on a priority basis considering other feasible systems (off-loading, others).
3. Planning Checklist: See Table 3.3.

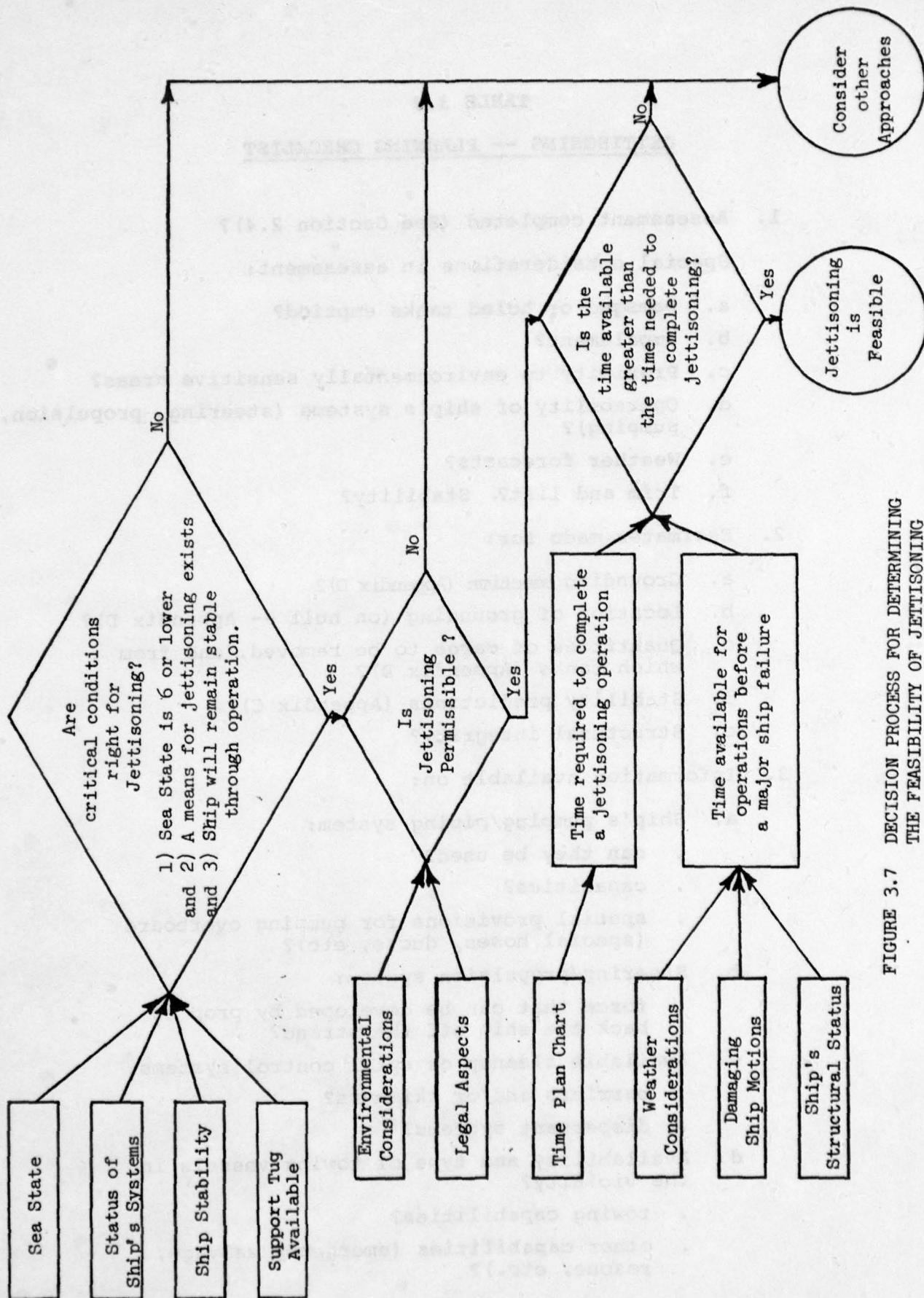

FIGURE 3.7 DECISION PROCESS FOR DETERMINING THE FEASIBILITY OF JETTISONING

TABLE 3.3

JETTISONING -- PLANNING CHECKLIST

1. Assessment completed (See Section 2.4)?

Special considerations in assessment:

- a. Damaged or holed tanks emptied?
- b. Impalement?
- c. Proximity to environmentally sensitive areas?
- d. Operability of ship's systems (steering, propulsion, pumping)?
- e. Weather forecasts?
- f. Trim and list? Stability?

2. Estimates made for:

- a. Grounding reaction (Appendix D)?
- b. Location of grounding (on hull -- Appendix D)?
- c. Quantities of cargo to be removed, and from which tanks (Appendix D)?
- d. Stability predictions (Appendix C)?
- e. Structural integrity?

3. Information available on:

- a. Ship's pumping/piping system:
 - . can they be used?
 - . capacities?
 - . special provisions for pumping overboard (special hoses, ducts, etc)?
- b. Steering/propulsion system:
 - . force that can be developed by prop to back the ship off the strand?
- c. Available cleanup or spill control systems:
 - . barriers and/or skimmers?
 - . dispersant systems?
- d. Availability and type of towing vessels in the vicinity?
 - . towing capabilities?
 - . other capabilities (emergency salvage, rescue, etc.)?

4. Selections made for:
 - a. Auxiliary towing vessel?
 - . towing gear?
 - . mooring systems?
5. Plans made for:
 - a. Jettisoning procedure?
 - . tanks to be jettisoned and order of jettisoning
 - . quantities to be jettisoned
 - . pumping or tank pressurization (blowing)
 - . timing for freeing at high tide
 - b. Tug assistance?
 - . tug-vessel interaction (passing tow lines, tow points)
 - . direction of tow
 - . stabilization during jettisoning (prevention of broaching, hardening on the strand, etc.)
 - . backup or supplemental towing vessel utilization.
 - c. Spill cleanup?
 - d. Protection of shorelines and critical areas?
 - e. Special provisions for the case of emergency jettisoning at the end of an off-loading operation:
 - . emergency jettisoning plan prepared?
 - . plans for rapid casting off of mooring lines, anchors, etc., prepared?
 - . are tugs/salvage vessels prepared for emergency towing?
 - . cleanup/dispersant equipment and plans ready, with proper EPA approvals?
6. Contingency plans prepared for:
 - a. Stabilization (ballasting, mooring) and off-loading if jettisoning is not proving successful?
 - b. Flaring cargo?
7. Safety considerations (See Appendix A)?

3.3.3

Approach: Bomb the Vessel and Burn the Cargo In-Situ

A. Application

1. Consider as a last resort when off-loading is unsuccessful and breakup is imminent. Bombing will probably destroy the ship.
2. Can be used on floating casualties if the risks in sinking the ship are acceptable (very deep water, away from land, etc.)

B. Description of Approach

1. The following components are required:
 - a. Bombs or missiles to open up the deck plating. Bombs can be two-part devices such as used on the Torrey Canyon: the initial impact to open the hull plating, with a time-delayed explosion occurring after the penetration to ignite the cargo. Special missiles would probably improve effectiveness, however. Depth charges are not recommended.
 - b. Aircraft to deliver the bombs or missiles. Air Force or Navy planes would be required.
 - c. Military vessels or combat helicopters, to provide fire-power to opening up holes in the side of the vessel (wing tanks) to promote more complete burning.
 - d. Spotter vehicles to report on damage incurred.
2. Planes would bomb the deck, opening up holes and igniting the cargo. Approximately 10-percent of the deck above a specific tank must be opened to ensure maximum combustion.
3. After sufficient oil is burned off to lower the tank level, fire-power should be used to open vent holes in the side of the tank to enhance combustion. A 10-percent opening is desirable.
4. Observations must be made to observe changes in vessel draft, additional oil spillage, and other indications of effectiveness.
5. After burning is completed conventional salvage operations can be undertaken.

C. Variations on Basic Approach

1. Explosives (cutting charges) could be planted on the vessel by explosives experts, thus ensuring that adequate openings were made. However, the presence of girders and other structural members below the deck could make this a difficult task, and would call for careful and time consuming planning. Side openings could also be made with planted explosives, or else shelling could be used. Incendiary charges or bombs could be used to ignite the cargo.
2. Homing devices placed on specific deck locations might improve the accuracy of missiles, particularly when smoke obscures the view. Special missiles would be required for this, however.
3. Incendiary bombs could be used to enhance ignition if the initial bombing fails to ignite the cargo.

D. Advantages

1. Effects of operations or weather on personnel are small because nobody can be present on the casualty during burning.
2. Bombing may be the only thing that can be done in certain circumstances, and even though it may be largely ineffective it indicates that an effort is being made.
3. No logistical problems such as providing receiving vessels for off-loaded oil.

E. Disadvantages

1. After initial ignition, smoke may obscure visibility for making additional bomb or missile hits (not a problem with planted explosives).
2. Openings of 10-percent in a tank represent extremely large areas for a large tanker. Projectiles tend to open up a small hole and depend on the explosion to open up larger areas.
3. The risk of causing more damage and pollution than might be saved is great in the case of bombing.
4. Certain viscous cargos may not burn (on the order of 5,000 cs or greater).

5. Air pollution could be a problem.
6. Burning rates are fairly slow, at best. For a fully vented tank (10-percent on side and top) and a 12-knot wind feeding the flame, a burning rate of 7 inches per hour might be obtained under optimum conditions.
7. Center tanks are not amenable to side venting by gun fire or planted explosives.
8. Monitoring burning effectiveness is not easy compared to offloading.
9. Burning is uncontrollable after ignition.
10. With planted explosives, initial detonation and/or heat may cause disruption of electrical (denotation) circuits and other problems. All charges may have to be set off at once.
11. Bad weather could make planting explosives very hazardous, especially along the sides of the vessel.
12. Mobilization times for planting explosives could be long.
13. Bombing may sink a floating ship (desirable in certain cases).
14. The vessel will probably be destroyed.

F. Special Problems/Techniques for Extreme Weather

1. Setting explosives can be difficult in bad weather.
2. Poor visibility in bad weather can limit bombing or shelling operations.

G. Planning Considerations

1. Time Plans: Diagrams similar to other Time Plans can be prepared for this operation. Planting explosives appears to be the preferred means to success for opening up the deck, but this requires the most planning and preparation. Much of this planning effort must be performed after the casualty occurs, thus making this a slow response operation.
2. Planning checklist: See Table 3.4.

TABLE 3.4

BOMBING AND/OR EXPLOSIVES -- PLANNING CHECKLIST

1. Assessment completed (See Section 2.4)?
Special considerations in assessment:
 - a. Condition of vessel
 - b. Vessel structural data and tank layout
 - c. Cargo condition (quantities, estimated viscosity)
 - d. Vessel/cargo condition as a result of any other response techniques that have been attempted (off-loading, jettisoning, etc.)
2. Estimates made for:
 - a. Ground reaction?
 - b. Location of grounding?
 - c. Quantities of cargo to be removed, from which tanks?
 - d. Damage probability as result of burning and bombing (structural weakening, etc.)?
 - e. Explosives/ordnance required?
3. Information available on:
 - a. Location and availability of suitable aircraft? Gunboats? Combat Helicopters?
 - b. Location and availability of suitable ordnance (special -- bombs, missiles)?
 - c. Supply of explosives (special configurations of shaped charges, mounting hardware, detonating equipment)?
 - d. Structural drawings of ship, showing deck reinforcing, tank locations, etc.
 - e. Status of all cargo compartments amenable to bombing/explosives (oil quantity remaining, oil type and viscosity)
 - f. Response times
4. Selection made for:
 - a. Combat aircraft
 - . quantity?
 - . type?
 - . source?
 - . function (bombing, missile launching)

- b. Ordnance and explosives
 - . type?
 - . quantity?
 - c. Gun boats
 - . quantity?
 - . ordnance capabilities?
 - d. Staging sites?
 - e. Evaluation techniques?
 - f. Surveillance methods?
 - g. Personnel?
 - . aircraft and vessel crews
 - . explosives experts (special contractor or military)
 - . system design group for planning explosives layout and evaluating effects of explosives (or bombs) on ship structure
 - . evaluation crews (post burning)
5. Plans prepared for:
- a. Contracting with explosives/ordnance consultants (commercial and/or military)?
 - b. Mobilizing aircraft and vessels?
 - c. Bombing/missile pattern?
 - d. Layout of explosives and detonation sequence?
 - e. Delivery of explosives (ordnance, explosives) to vessel?
 - f. Vessel inspections before and after burning?
 - g. Towing or salvage of remains of vessel?
 - h. Documenting questions?
6. Contingency plans prepared for:
- a. Oil spill control and cleanup?
 - b. Additional burning or explosives setting where initial failures occur?
7. Safety considerations (See Appendix A)

3.3.4

Approach: Cargo Gelling

A. Application

1. Where a vessel tank is in danger of opening and oil could be spilled.
2. Before towing a casualty, to minimize spillage if further damage occurs.

B. Description of Approach

1. The following components are required:
 - a. Gelling agent: Although several types of agents will form gels with oil, only certain polymer forming organic reagents will work at reasonable ratios of agent-to-oil. Even then, quantities of 3 to 10 percent of the oil weight are required to provide adequate shear strength (e.g., the center tanks on a 100,000 DWT tanker could contain 7,700 tons of oil and would require as much as 770 tons of gelling agent).
 - b. Mixing equipment: The gelling agent must be thoroughly mixed with the oil, at an energy input of approximately 1 Hp-minute/1,000 gallons. Mixing could be provided by circulating oil through an eductor, using an ADAPTS pump.
 - c. Test equipment to measure the shear strength of the gel (1.2 psi shear strength necessary to prevent extrusion through all but very large holes).
 - d. Cargo heating equipment: Low temperatures will cause lower shear strengths to develop for a given quantity of gelling agent (at 4°C shear strength for 3% agent is 0.7 psi; at 15°C shear strength increases to 1.2 psi). To reliquefy the gel, it must be heated to approximately, 54°C, but this would be done in port. Heat transfer to a gelled, semi-solid cargo would be a problem.
2. Mix the gelling agent thoroughly with the oil at the recommended energy input. If any water is present a good gel will not form. (However, a formed gel is stable in the presence of water.)
3. Allow the mixture to react for 8 to 24 hours until the proper shear strength is achieved.

4. Tow the vessel to port for off-loading the cargo.

C. Advantages

1. The possibility of oil leakage and pollution is reduced if the cargo is gelled.
2. Free-surface effects on vessel stability are reduced if the cargo is gelled.

D. Disadvantages

1. Providing 3 to 10 percent gelling agent to a casualty presents a logistics problem almost as severe as direct off-loading of liquid cargo.
2. Gelling agents are expensive.
3. The cargo is contaminated by the addition of the gelling agent.
4. The presence of water is detrimental to gel formation; therefore, holed tanks cannot be treated effectively.
5. Heating equipment is difficult to mobilize and deploy.
6. Cleaning or disposing of the vessel after gelling would be a problem.

E. Planning Considerations

Because of the serious drawbacks to the use of gelling as a response method, no planning guidelines have been developed.

4.0 OIL SPILL MITIGATION AND CLEANUP

The objective of responses in the event of a spill is to minimize the resultant environmental pollution. The techniques discussed are applicable to spills from tankers, oil well blow-outs, pipeline ruptures and other sources. Although several response approaches are possible, they fall into one of the two following categories:

1. Skim the oil from the water surface and remove it from the environment.
2. Redistribute the oil or its decomposition products throughout the environment.

Category 2 can be further subdivided as follows:

1. The use of chemical dispersants to remove oil from the water surface and suspend it as droplets in the water column.
2. In-situ slick burning to remove the oil from the water surface.
3. Sinking of the oil slick by adding suitable materials.

Only the first of the Category 2 techniques is considered to be viable at this time. Burning is not well developed, and sinking is not permitted in U.S. waters.

Response approaches can also be categorized in other ways. Table 4.1 categorizes the response approaches as "system types", for both skimming and redistribution approaches. These system types represent basic functional approaches that may be available to the OSC in planning a skimming or dispersant operation. Within each of the skimming system types, for example, the skimming devices and the basic skimming mechanisms (the means of actually removing the oil from the sea surface) may differ considerably. Appendix H presents a summary of the basic skimming mechanisms that are employed in various skimming devices.

TABLE 4.1. SPILL MITIGATION AND CLEANUP

I. SKIMMING APPROACHES

A. Barrier Systems. Variations include:

1. Skimmer operates independently inside the apex of the barrier.
 - a. Skimmer tethered in the apex of the barrier, and umbilical-supported by a vessel some distance away.
 - b. Skimmer supported from a boom which is mounted on a vessel located adjacent to the apex of the barrier.
 - c. Self-propelled skimmer, remote-controlled from a nearby vessel.
2. Skimmer part of the barrier envelope
 - a. Skimming mechanism built into the barrier
 - b. Skimmer with herding barriers attached to the hulls

B. Direct-Acting Skimmers (No Long Barriers)

1. Dedicated, independent skimmers
2. Vessel-of-Opportunity Skimming Systems (VOSS)

II. REDISTRIBUTION APPROACHES

A. Dispersant Systems

1. Aircraft applied dispersants
2. Vessel applied dispersants

B. In-Situ Slick Burning

C. Slick Sinking

4.1 Response System Selection

Figure 4.1 describes a general outline for deciding the best course of action for a spill response, along with several of the principal factors to be considered. Several of the key questions listed on the diagram are discussed below:

. Does the Coast Guard have geographic jurisdiction for removing the discharged oil? Coast Guard geographic jurisdiction for responding to an oil spill is cited in the Clean Water Act Amendments of 1977, 33 USC 1321(c)(1). It states that removal is authorized if the discharge occurs into or upon the navigable waters of the U. S., the contiguous zone, adjoining shorelines, or in connection with activities under the Outer Continental Shelf Lands Act, the Deepwater Port Act of 1974, or the Fishery Conservation and Management Act of 1976. A removal operation is also authorized if the spill poses a substantial threat to these waters.

. Can skimmers be used? If the spill occurs in, or threatens, waters for which the Coast Guard has responsibility for removal actions, the OSC should determine if skimmers can be utilized. From an environmental standpoint, skimming is preferred to other treatment methods because it removes the pollution from the environment. It is usually desirable to utilize skimmers when the following conditions exist:

1. A thick (1-5mm) oil slick exists (near the spill source or in windrows).
2. The slick covers an area where environmental risks from dispersed oil are great (for example, near shell fishing areas).
3. Sea and weather conditions are expected to be within operational or survival limits.

If skimmers cannot be used, because the oil is too thin or weather conditions preclude skimming, then dispersants will have to be considered. If skimming is possible, then an examination of system availability should be made. A likely case is that skimmers can be utilized on part of the slick but not on all of it. In this case, different areas of the slick should be considered separately in the decision making process.

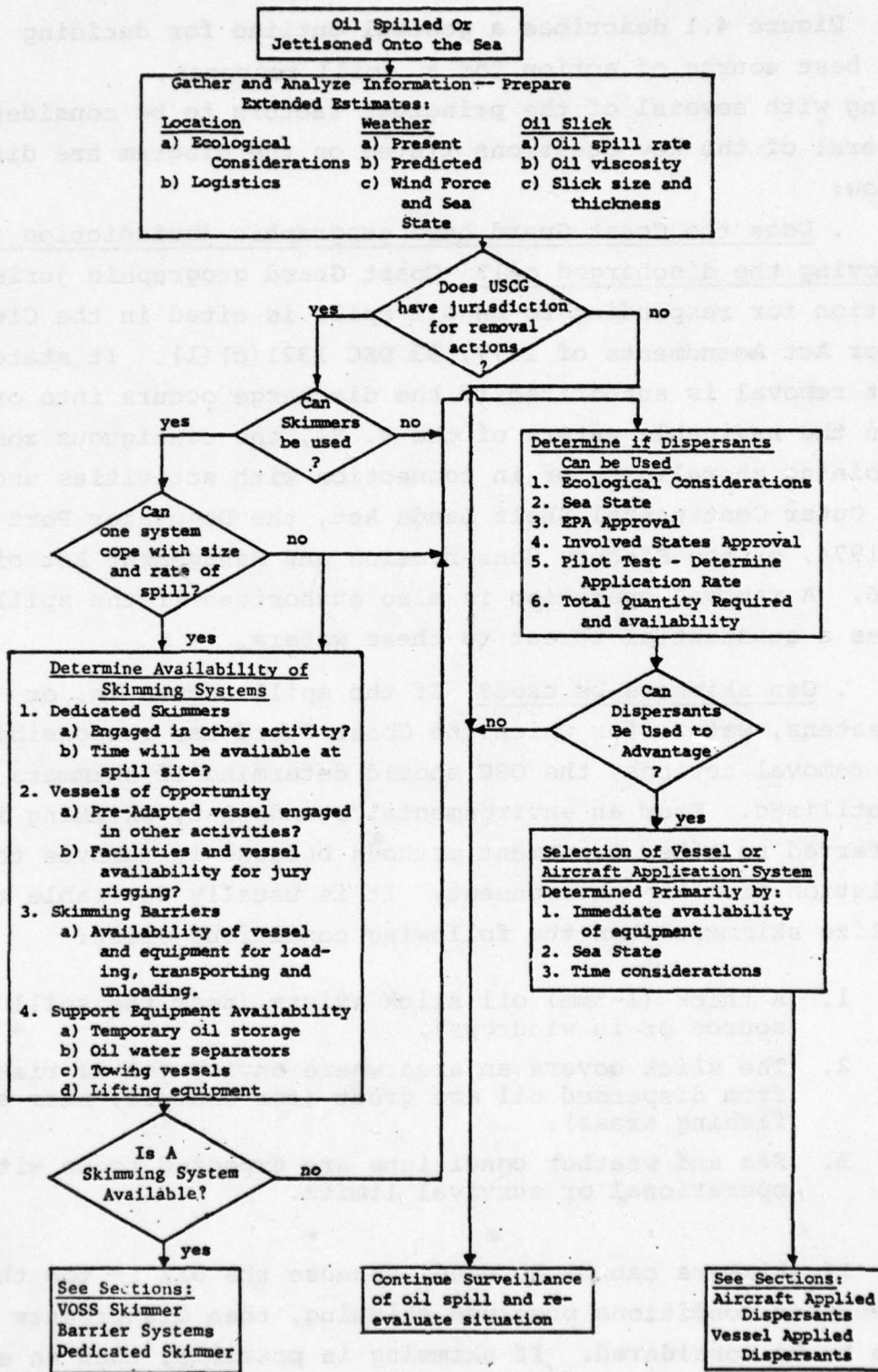

FIGURE 4.1 SELECTION OF A SPILL RESPONSE APPROACH

. Is a skimming system available? Later sections in this guide discuss the types of skimming systems that can be used. Prior planning by the OSC will determine what specific systems and equipment are available to him. An estimate of the spill and environmental conditions will then narrow the choice. A final choice would be made considering the best response time, ease of control, and other factors. For a large spill several systems may be required, and possibly not enough skimmers can be made available. In this case, consideration of dispersants is again required.

. Can dispersants be used to advantage? In general, it is simpler to apply dispersants to the oil than it is to skim it. From Tables 5.3 and 5.5, the sea state capabilities of dispersant techniques exceed the capabilities of available skimming approaches, although logistics and operational problems are not simple. Details of the various dispersant techniques are discussed later. It may be desirable to utilize dispersants when the following conditions exist:

1. A thin (<1mm) wide-area slick exists.
2. The oil slick covers an area where environmental risks are minimal (offshore, favorable current, deep water, etc.).
3. Conditions are too extreme for skimming techniques, but aircraft or vessel application of dispersants can be utilized.

The second condition above is most critical, and regulations are in force to ensure that dispersants are not used in an indiscriminate manner that might harm aquatic life. Some of the considerations in these regulations are shown in Figure 4.1. Annex 10 of the "National Oil and Hazardous Substances Pollution Contingency Plan" gives full details. At the present time a study is being performed by the EPA to develop better guidelines for the use of dispersants.

4.2 Response System Descriptions

The following sections describe in more detail the basic system approaches that can be considered in planning operations. Time plan diagrams are shown in many cases, and diagrams are presented outlining the general considerations to be made in determining if the approach is feasible. Of the feasible approaches, the ones that, in the opinion of the OSC, best meets the priorities below should be pursued:

1. Low residual pollution (pollution that cannot be controlled by the response method, or that is a result of the response method, e.g. dispersants).
2. Low risk to personnel and response equipment
3. Fast response time

Details of specific equipment items and support systems are presented in Section 5.

4.2.1

Approach: Vessel-of-Opportunity Skimming System (VOSS)

A. Applications

1. Relatively thick slicks (1-5mm or greater) in windrows and patches, in sea conditions up to Sea State 4 to 5 depending on the design.
2. Where higher maneuverability than can be provided with large sweeping barrier systems is required.

B. Description of Approach

1. The following components are required:

- a. Vessel of opportunity

Some criteria for vessel selection for rough weather use are:

- . seaworthy in Sea State 4 and above (implies 160 feet or longer).
- . large open deck area for support equipment (such as power modules, lifting gear, pumps, manifolds, etc.).
- . capable of operating continuously at less than 3 knots.
- . some on-board oil storage capability is necessary, whether it be from integral or portable tankage.

The likelihood of acquiring a suitable vessel on short notice, without prior arrangements, could be low. The OSC must identify suitable vessels within his area of responsibility, and be prepared to obtain them when necessary.

Potential vessels may include:

- . Commercial vessels:
 - . offshore supply boats
 - . towed small barges
 - . small tankers
 - . tugboats
 - . dredges
 - . fishing vessels

- . Coast Guard vessels:
 - . WLB 180-foot buoy tenders
 - . WMEC 210-foot medium endurance cutters
 - . Other Government vessels:
 - . ASR
 - . ARS
 - . ATF
 - . smaller AGORs
 - . small tankships.
- b. A skimming device that can be placed over the side of of the vessel and operated from the vessel. At the present time several promising VOSS skimming devices for rough water include:
- . sorbent rope concepts (under development)
 - . loose sorbent systems (none available at this time).
 - . the SOCK skimmer (under development).
 - . the Spring Sweep skimmer (Warren Spring Laboratory design - under development)
- Table 5.3 describes other devices that may be used for VOSS application in the lower sea states.
- c. Handling and lifting system for the skimming apparatus. Separate equipment may have to be provided, although some skimmers may be equipped with their own integral handling system.
 - d. Storage tanks for recovered oil.
 - e. Slick surveillance function for directing the vessel to new patches of oil (other vessels, aircraft).
2. Vessels of opportunity would be obtained and the equipment would be installed on it at the time of a spill.
 3. Surveillance vehicles (boats, aircraft) would proceed to the spill site to direct the VOSS to the thicker regions of the slick. Slick trajectory forecasting would be utilized, also.
 4. VOSS system would proceed to the spill site, deploy skimmers, and commence skimming operations.
 5. Recovered oil, would be transferred off the VOSS periodically.

C. Variations on Basic Approach

1. Various means of storing and handling recovered oil can be utilized. (Interim storage of skimmed oil/water mixtures can be provided by:
 - a. Integral tankage on-board the VOSS (some supply boats, tank ships, towed barges).
 - b. Temporary deck-mounted tankage (steel tanks, rubber pillow tanks -- vessel stability must be considered).
 - c. Towed vessels (Dracones or other bladders, small barges -- restricts maneuverability of VOSS).

Bulk storage can be provided in two ways:

- a. At-sea transfers from interim storage to large barges or tankers maintained in the vicinity of the spill (difficult operations in extreme weather).
 - b. Transfers to shore-side tankage (or direct to disposal facilities) via pipelines, tank trucks, or vacuum trucks brought to pier-side (time-consuming for remote spill).
2. Vessels of opportunity could be obtained in various states of readiness:
 - a. Pre-adapted, with special fittings, etc., already installed to receive specific skimming equipment in the event of a spill (needs outfitting at a pier, or possibly via helicopter delivery).
 - b. Pre-adapted, with skimming equipment permanently stored on-board for rapid assembly (can outfit in-transit to the spill).
 - c. Random vessels with no pre-adapting (most common, but most difficult and time-consuming to outfit).

Types (a) and (b) require advanced planning, and probably long-term contractual arrangements if non-military vessels are involved.

D. Advantages

1. Provides a relatively small, self-contained, and highly maneuverable skimming system.
2. Provides a seaworthy vessel for personnel and support, while allowing the skimmer/boom apparatus to be small and light to conform with the wave profiles.
3. Reduces overall cost of a complete skimming system (over a dedicated skimmer).
4. Provides a quick response potential if vessels are properly equipped ahead of time.

5. Skimming apparatus is relatively small, portable, and can be stored at several locations.
6. Survivability of system is high because the skimming apparatus can be pulled back on deck.
7. Because large containment booms are not involved, skimming speed in some cases can be increased from 1 to 3 knots.

E. Disadvantages

1. Success depends on having the right vessels available when needed. Previous commitments by vessels can make them unavailable.
2. Vessel crews may be untrained in skimming operations.
3. Installation of equipment can be time consuming on a random vessel -- slow response speed.
4. Lack of interim oil storage tanks can limit operational times.
5. Good setups are not commonly available.
6. Skimming rates are relatively low (compared to barrier systems).

F. Special Problems/Techniques for Extreme weather

1. If bulk oil storage is provided by a barge that has been towed to the vicinity of the spill, transfers from the VOSS may be more easily made in higher sea states if the barge is first taken in tow by the VOSS itself. Transfers can be made by pumping the oil through a floating or suspended hose.
2. Downwind skimming may improve skimming efficiency, because the frequency of wave encounter is reduced and adverse skimmer and vessel motions are minimized.

G. Planning Considerations

1. Time Plans: Figure 4.2 shows an example Time Plan for the situation where a supply boat is outfitted with a skimmer at a pier (staging area). The VOSS then proceeds to the spill area where it takes a barge in tow to provide for interim storage during skimming operations. A considerable amount of time is shown for obtaining and outfitting the supply boat. Careful planning can help to minimize the delays in this step.

2. Decision Diagram: Figure 4.3 shows a general Decision Diagram for determining if the VOSS approach will provide an adequate response time in the event of a spill.
3. Planning Checklist: See Table 4.2.

FIGURE 4.3 TIME PLANE FOR VOSS OF OPPORTUNITY EXISTING SYSTEM
(VOSS) AND DEDICATED SYSTEM

Decision Diagram: Figure 4.3 shows a general Decision Diagram for determining if the VOSS approach will provide an adequate response time in the event of a spill.
Planning Checklist: See Table 4.5.

FIGURE 4.2 TIME PLANS FOR VESSEL-OF-OPPORTUNITY SKIMMING SYSTEM (VOSS) AND DEDICATED SKIMMER

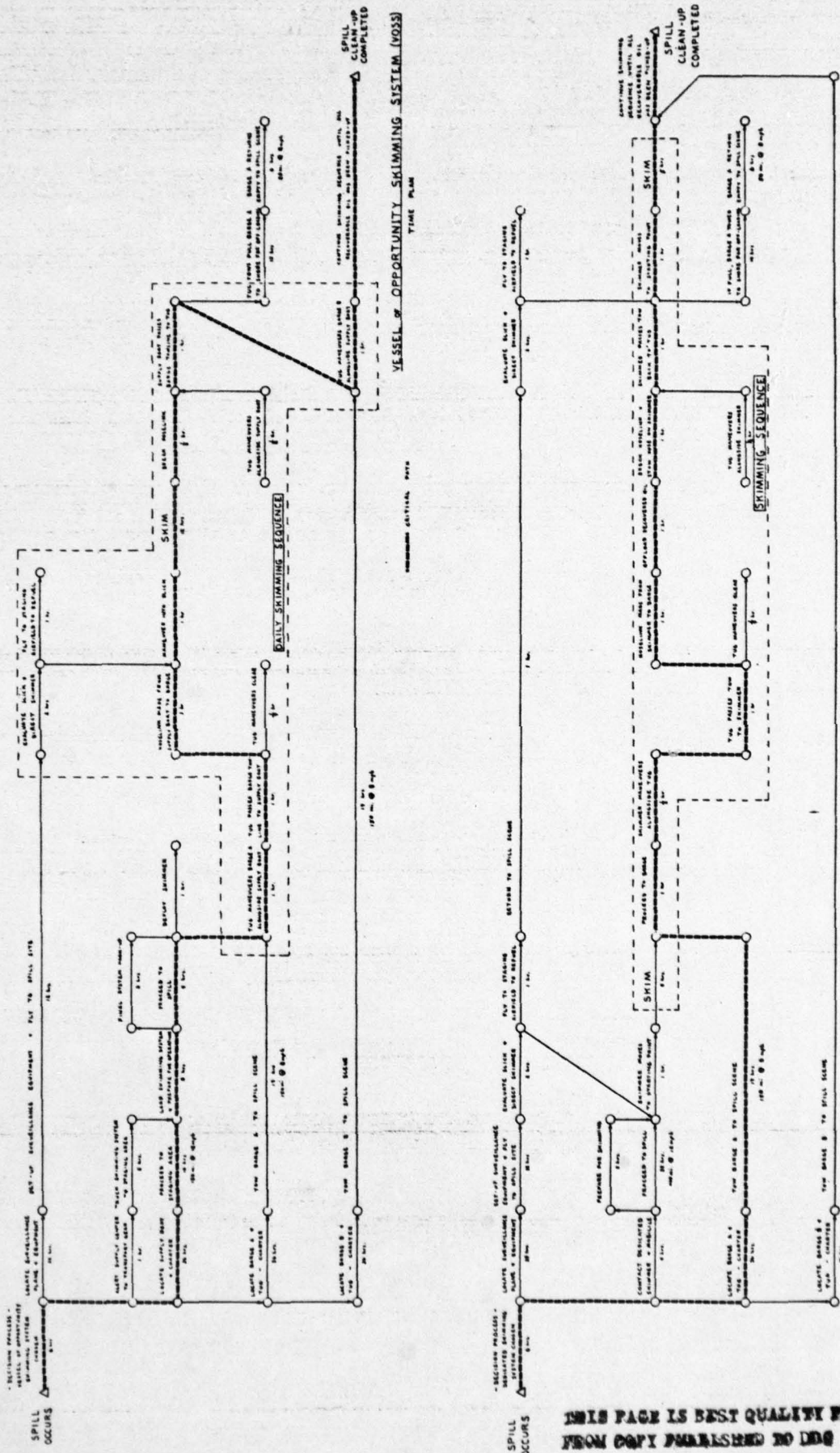

THIS PAGE IS BEST QUALITY PRACTICAL FROM COPY FURNISHED TO DDC

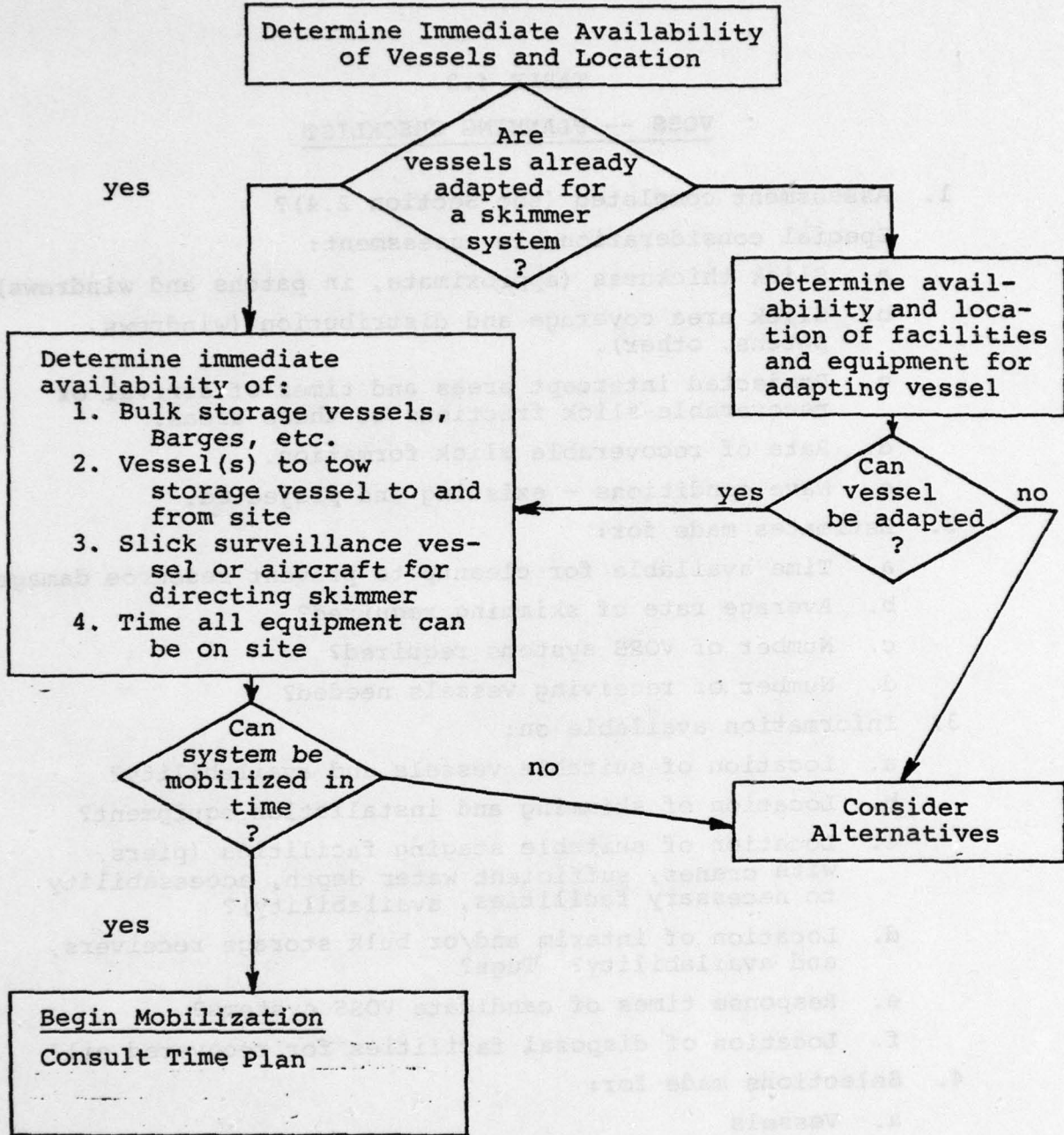

FIGURE 4.3
VESSEL OF OPPORTUNITY SKIMMING SYSTEM (VOSS) CONSIDERATIONS

TABLE 4.2

VOSS -- PLANNING CHECKLIST

1. Assessment completed (see Section 2.4)?
Special considerations in assessment:
 - a. Slick thickness (approximate, in patches and windrows).
 - b. Slick area coverage and distribution (windrows, patches, other).
 - c. Projected intercept areas and times of arrival of recoverable slick fractions at these areas.
 - d. Rate of recoverable slick formation.
 - e. Wave conditions - existing and projected.
2. Estimates made for:
 - a. Time available for cleanup to prevent resource damage?
 - b. Average rate of skimming required?
 - c. Number of VOSS systems required?
 - d. Number of receiving vessels needed?
3. Information available on:
 - a. Location of suitable vessels and availability?
 - b. Location of skimming and installation equipment?
 - c. Location of suitable staging facilities (piers with cranes, sufficient water depth, accessibility to necessary facilities, availability)?
 - d. Location of interim and/or bulk storage receivers, and availability? Tugs?
 - e. Response times of candidate VOSS systems?
 - f. Location of disposal facilities for recovered oil?
4. Selections made for:
 - a. Vessels
 - . number?
 - . type?
 - . additional interim storage requirements?
 - . extra on-board handling equipment?

- b. Appropriate skimming equipment for above vessels?
 - . delivery system (truck, helicopter)
 - c. Barges or other towable bulk storage receivers?
 - . pumps and/or hoses?
 - . personnel protection aboard barge?
 - d. Staging sites
 - . loading equipment?
 - . suitable for vessel draft?
 - e. Recovered oil off-loading sites?
 - . supplementary pumping equipment?
 - . tank trucks?
 - . storage tanks?
 - . disposal sites?
 - . debris handling?
 - f. Surveillance methods?
 - . aircraft?
 - . vessels?
 - . special equipment for estimating slick thickness?
 - g. Personnel
 - . skimmer crews?
 - . surveillance crews?
 - . barge crews?
 - . other?
5. Plans made for:
- a. Chartering vessels?
 - b. Arranging for access to staging areas, off-loading piers?
 - c. Delivery of skimming equipment?
 - d. Skimming patterns?
 - e. Cargo transfers (VOSS to other receivers)?
 - f. Surveillance patterns?

- g. Documenting operations?
 - . operations log
 - . determining cleanup effectiveness
 - . updating slick location and configuration
 - . photography
- h. Schedule for refueling? crew changes?
- 6. Contingency plans prepared for:
 - a. Booming of environmentally sensitive areas?
 - b. Dispersant application if skimming is ineffective?
 - c. Survival operations?
- 7. Safety considerations. (see Appendix A)?

- g. Documenting operations?
 - . operations log
 - . determining cleanup effectiveness
 - . updating slick location and configuration
 - . photography
- h. Schedule for refueling? crew changes?
6. Contingency plans prepared for:
 - a. Booming of environmentally sensitive areas?
 - b. Dispersant application if skimming is ineffective?
 - c. Survival operations?
7. Safety considerations. (see Appendix A)?

4.2.2

Approach: Containment Barrier Assisted Skimming

A. Application

1. Relatively widespread slicks, either thick or thin, in sea conditions up to State 3 or possibly 4 depending on the system components.
2. For open water, where high maneuverability is not required.
3. Where high skimming rates are desired.

B. Description of Approach

1. The following components are required:
 - a. Containment barrier: Various types can be used depending on the sea conditions. For the highest sea state capability (3 to 4), the Coast Guard OWOCS should be utilized. Characteristics of other barriers are given in Table 5.4. The length required may depend on the size of the slick and other factors, but in general, approximately 600 feet will be satisfactory, deployed with a 400-foot opening.
 - b. Skimmer: Various types of skimmers can be utilized. All types are designed to operate in the thick (4-6 inches) pool of oil that accumulates in the apex of the barrier. Table 5.3 gives characteristics of the various types of skimmers that can be used, including the Coast Guard skimming barrier.
 - c. Storage vessel for recovered oil: The skimmers for this service have essentially no on-board oil storage capacity, and all of the oil must be stored in a barge or tankship. Dracones or other unmanned receivers could be difficult to work with in the higher sea states.
 - d. Vessels for towing the barrier, skimmer and recovered oil receiver. The vessels should be capable of:
 - . sustained towing at speeds of 1 knot or less
 - . operation and survival in the sea states expected
 - . capable of extended operation at sea

Vessels suitable for towing operations in the higher sea states include but are not limited to:

- . Offshore supply boats (commercial) with controllable pitch (CP) propellers and bow thrusters.
 - . WLB buoy tenders
 - . Certain coastal buoy tenders
 - . WMEC cutter (possibly)
 - . Navy ATF tugs
- e. Delivery system for equipment: This will depend on the equipment to be used and may possibly be accomplished by one of the towing vessels.

Probably the best delivery system for the higher sea states is a 160-foot or larger offshore supply boat, equipped with an A-frame and a stern roller. The size of such a vessel makes it a good platform to work from in assembling a skimmer and/or in preparing a barrier for launching. An entire system could possibly be preassembled on deck, even to the point of starting the skimmer mechanism (unless remotely startable) and passing the transfer hose beneath the barrier. A possible layout utilizing the OWORS skimmer and OWOCS barrier just before launching is shown in Figure 4.4.

Use of the Coast Guard sled (FDS) in higher sea states could possibly be utilized, but would offer no advantages over the supply boat delivery method. Transport speeds would be limited by towing vessel motions and motions of the sled itself. At the work site, assembly would have to be done in the water, which would be undesirable in heavy weather. In lower sea states, the FDS would be a good vehicle for delivering both the OWOCS barrier (which can be used to corral the oil initially) and the OWORS skimmer. The skimmer could also be delivered and deployed by a 180-foot WLB in very low sea states (3-foot waves or less).

- f. Slick surveillance function: Because of the limited maneuverability of barrier systems, a continuous slick spotting function is not necessary.
2. The barrier would be loaded onto a delivery vessel, transported to the spill, and deployed.
 3. Towing vessels would be obtained, dispatched to the spill, and take the barrier in tow. Other vessels would also be dispatched to perform other required functions, depending on the system.

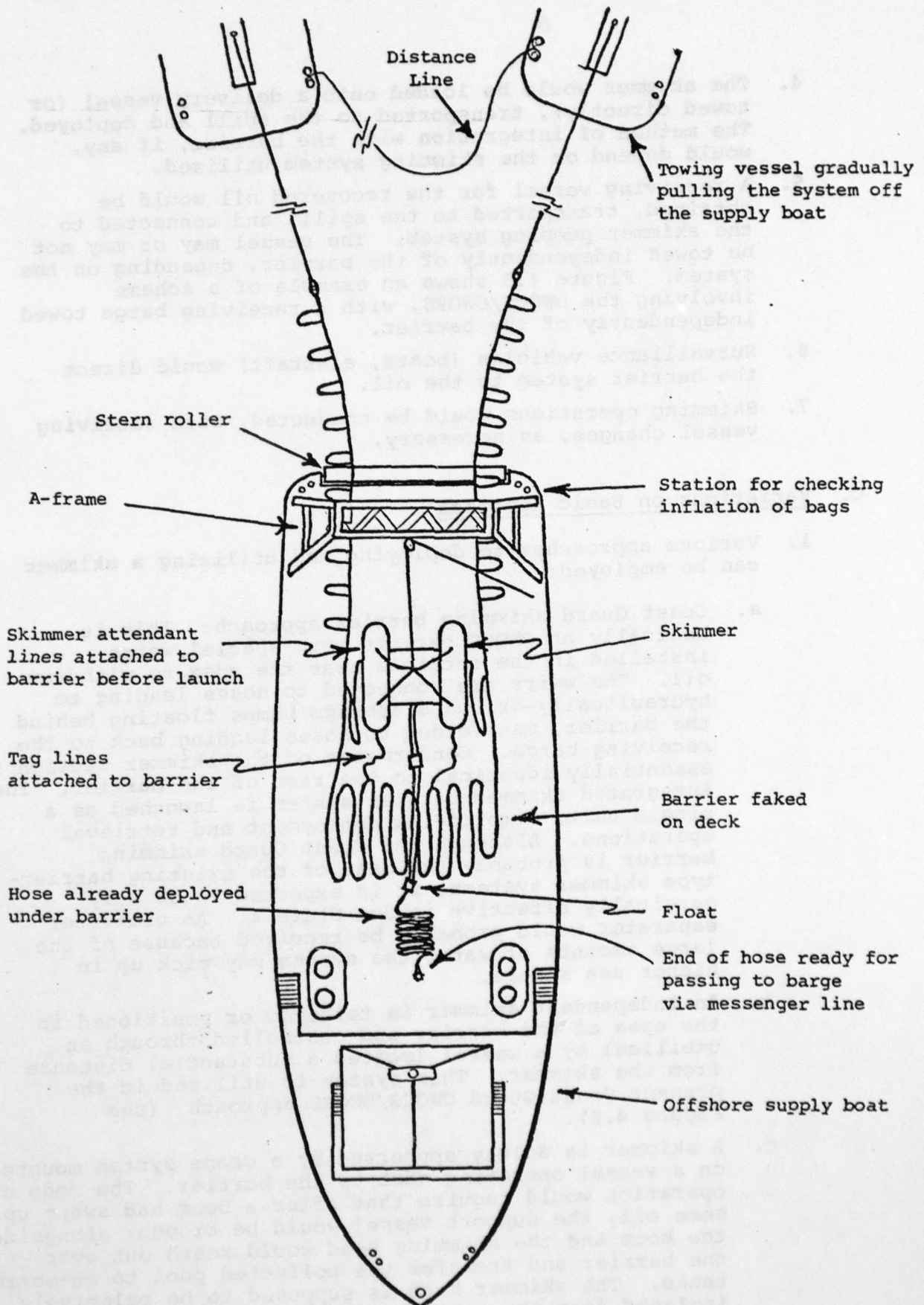

FIGURE 4.4 INDEPENDENT SKIMMER AND BARRIER WITH DISTANT SHIP SUPPORT -BEFORE LAUNCHING

4. The skimmer would be loaded onto a delivery vessel (or towed directly), transported to the spill and deployed. The method of integration with the barrier, if any, would depend on the skimming system utilized.
5. A receiving vessel for the recovered oil would be obtained, transported to the spill, and connected to the skimmer pumping system. The vessel may or may not be towed independently of the barrier, depending on the system. Figure 4.5 shows an example of a scheme involving the OWOCS/OWORS, with a receiving barge towed independently of the barrier.
6. Surveillance vehicles (boats, aircraft) would direct the barrier system to the oil.
7. Skimming operations would be conducted, with receiving vessel changes, as necessary.

C. Variations on Basic Approach

1. Various approaches to deploying and utilizing a skimmer can be employed:
 - a. Coast Guard skimming barrier approach: This is basically an OWOCS barrier with special weirs installed in the sections near the apex to withdraw oil. The weirs are connected to hoses leading to hydraulically-driven diaphragm pumps floating behind the barrier, manifolded to hoses leading back to the receiving barge. Conformance of the skimmer section is essentially identical to the rest of the barrier. The integrated skimmer-barrier system is launched as a single unit, simplifying deployment and retrieval operations. Although the Coast Guard skimming barrier is probably the best of the existing barrier-type skimmer systems, it is expected to be only marginally effective in Sea State 4. An oil-water separator would probably be required because of the large amounts of water the system may pick up in higher sea states.
 - b. An independent skimmer is tethered or positioned in the apex of the barrier and controlled through an umbilical by a vessel located a substantial distance from the skimmer. This system is utilized in the present Coast Guard OWOCS/OWORS approach (see Figure 4.5).
 - c. A skimmer is solely supported by a crane system mounted on a vessel operating next to the barrier. The mode of operation would require that after a boom had swept up some oil, the support vessel would be brought alongside the boom and the skimming head would reach out over the barrier and transfer the collected pool to on-board tanks. The skimmer head is supposed to be relatively isolated from the support vessel and free to conform

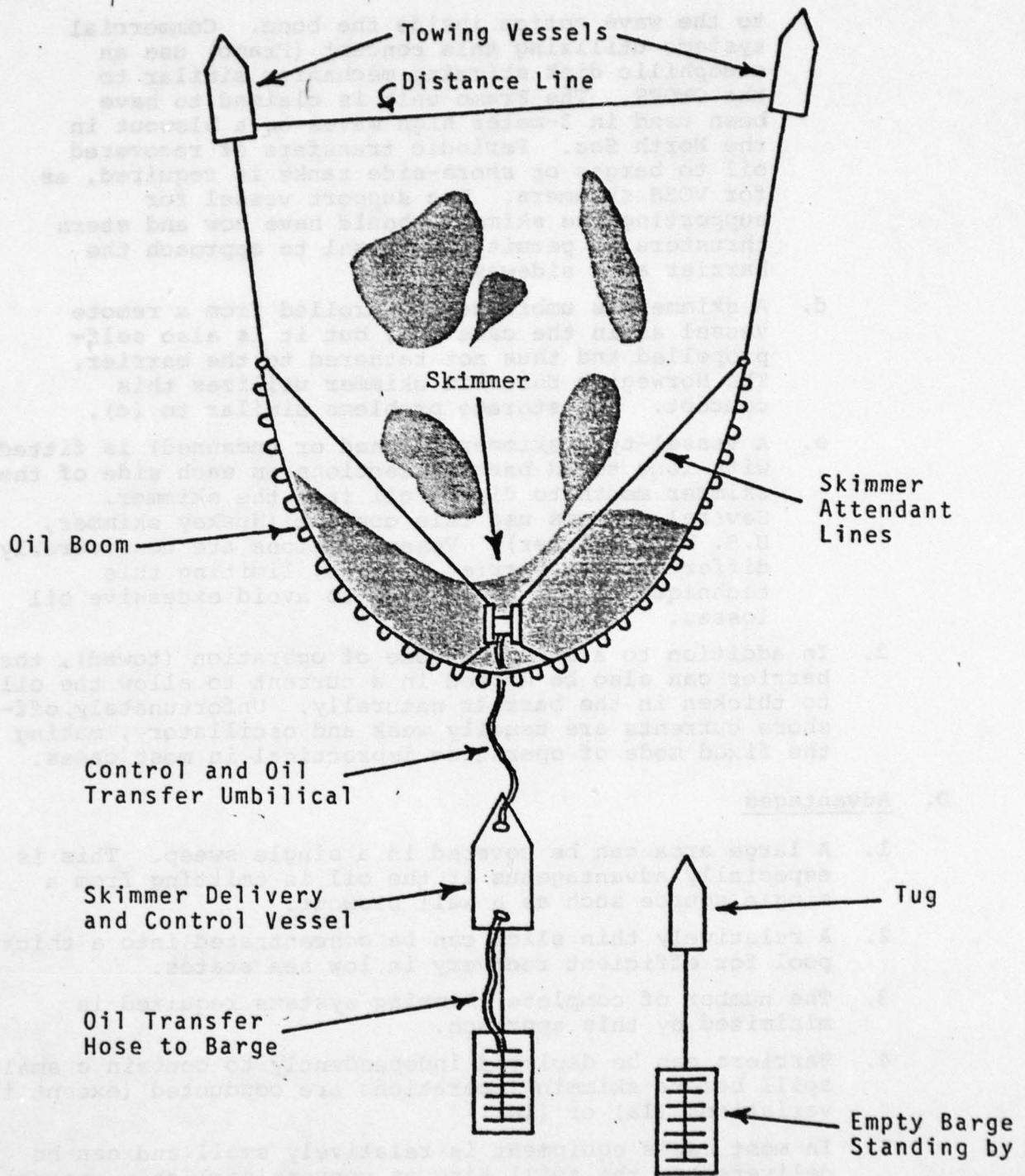

FIGURE 4.5 INDEPENDENT SKIMMER AND BARRIER WITH DISTANT SHIP SUPPORT — FULLY DEPLOYED

to the wave motion inside the boom. Commercial systems utilizing this concept (Framo) use an oleophilic disk skimming mechanism similar to the OWORS. The Framo unit is claimed to have been used in 3-meter high waves on a blowout in the North Sea. Periodic transfers of recovered oil to barges or shore-side tanks is required, as for VOSS skimmers. The support vessel for supporting the skimmer should have bow and stern thrusters to permit the vessel to approach the barrier apex sideways.

- d. A skimmer is umbilical-controlled from a remote vessel as in the case (b), but it is also self-propelled and thus not tethered to the barrier. The Norwegian Euroskim skimmer utilizes this concept. Oil storage problems similar to (c).
 - e. A vessel-type skimmer (manned or unmanned) is fitted with long towed barrier sections on each side of the skimmer mouth to direct oil into the skimmer. Several systems use this concept (Huskey skimmer, U.S. Navy skimmer). Vessel motions are considerably different than barrier motions, limiting this technique to low sea states to avoid excessive oil losses.
2. In addition to a sweeping mode of operation (towed), the barrier can also be moored in a current to allow the oil to thicken in the barrier naturally. Unfortunately, off-shore currents are usually weak and oscillatory, making the fixed mode of operation impractical in most cases.

D. Advantages

1. A large area can be covered in a single sweep. This is especially advantageous if the oil is emitting from a single source such as a well blowout.
2. A relatively thin slick can be concentrated into a thick pool for efficient recovery in low sea states.
3. The number of complete skimming systems required is minimized by this approach.
4. Barriers can be deployed independently to contain a small spill before skimming operations are conducted (except in variations (1a) or (1e)).
5. In most cases equipment is relatively small and can be delivered to the spill site at conventional ship speeds.

E. Disadvantages

1. System utilization is complicated and requires careful coordination between several vessels and equipment items. This is particularly difficult in extreme weather.
2. Barriers are limited to 1-knot tow speeds to avoid heavy oil losses.
3. Deployment of systems is more difficult than with other approaches (VOSS, dedicated skimming, dispersants). Hook-ups in the water (divers) may be difficult to impossible in extreme weather.
4. Maneuvering capability is limited.
5. Slow skimmer response in most cases. However, with good planning, reasonably rapid response with some systems can be obtained (USCG skimming barrier). The need to obtain several vessels at once is a disadvantage.
6. With variation (c) the close proximity of the skimmer vessel to the barrier makes this operation hazardous to the barrier and uncomfortable to the operator in higher sea states.
7. Survival potential of the equipment is reduced because of the difficulty of recovering it in bad weather and the need to leave it deployed in most cases.

F. Special Problems/Techniques for Extreme Weather

1. Downwind skimming may improve skimming efficiency, because the frequency of wave encounters is reduced and adverse skimmer and vessel motions are minimized.
2. Deployment/launching operations can be difficult to impossible to carry out safely. Systems may have to be assembled in calm water and towed to the site. This can slow the response speed significantly. Launching methods where devices can be pulled off a low, flat deck (work boat stern, barge deck) may be better than crane and boom launching methods.
3. Changing out a recovered oil barge could be difficult if it is being towed directly by the barrier or barrier towing vessels. In heavy weather, independent towing of the barge by a separate tug would permit faster break-away in an emergency, and, also provide continuous control of the barge. Because the barge towing vessel could also be functioning as the support platform for the skimmer machinery (power units, control panels, etc.), a transfer of a full barge to another towing vessel (and vice versa for the empty replacement barge) would be required.

G. Planning Considerations

1. **Time Plan:** Figure 4.7 shows an example Time Plan for a case similar to variation (b), where an independent skimmer is tethered in the apex of the barrier. The situation at the start of the launch sequence is shown in Figure 4.4. Figure 4.5 shows the setup after the receiving barge has been positioned and the skimming operation has commenced.

Figure 4.7 also shows steps in the launch sequence that would not be required if the Coast Guard skimmer-barrier was being utilized in a similar operation.

Other variations would have similar Time Plans, which would have to be developed around available equipment.

2. **Decision Diagrams:** Figure 4.6 shows a general Decision Diagram for considering the utilization of a barrier system for spill control, assuming sea state conditions are within limits for the system.
3. **Planning Checklist:** See Table 4.3.

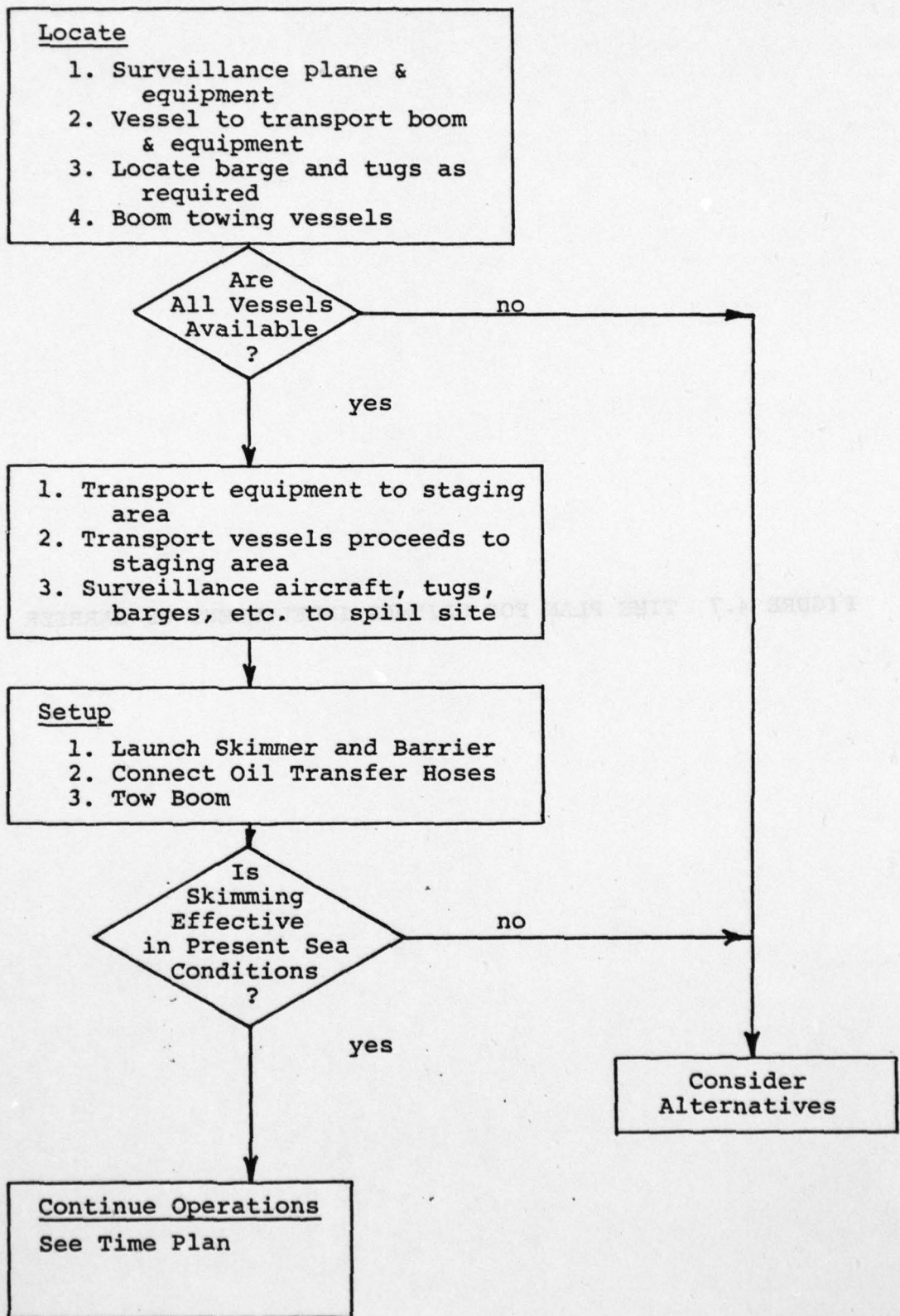

FIGURE 4.6 BARRIER USE CONSIDERATIONS

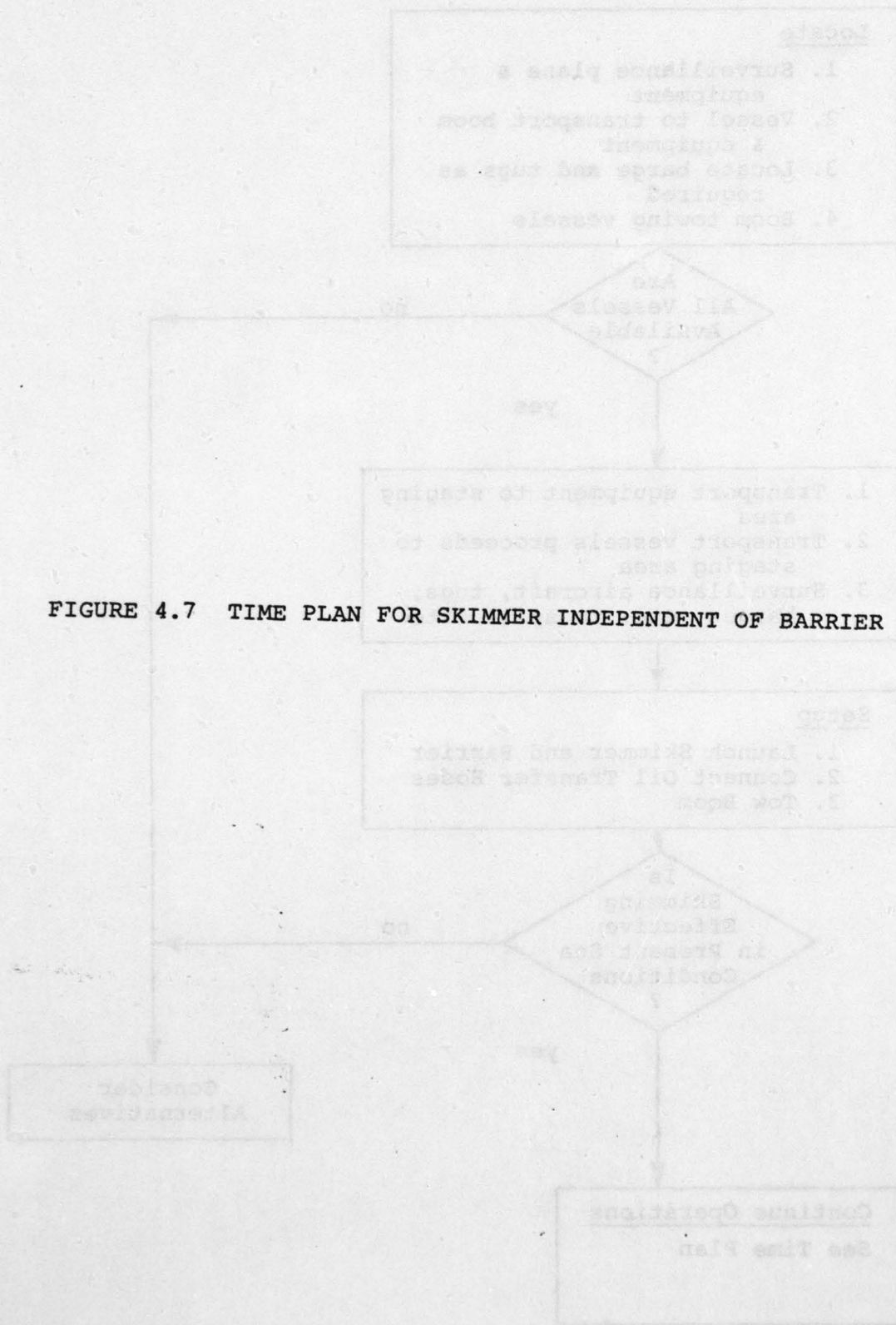

FIGURE 4.7 TIME PLAN FOR SKIMMER INDEPENDENT OF BARRIER

FIGURE 4.8 SKIMMER HAS CONSTRAINTS

AD-A079 714

SEAWARD INTERNATIONAL INC FALLS CHURCH VA
OIL POLLUTION RESPONSE PLANNING GUIDE FOR EXTREME WEATHER. (U)

F/G 6/6

NOV 79

DOT-CG-80372-A

NL

UNCLASSIFIED

USCG-D-3-80

2 OF 3

AD
A079714



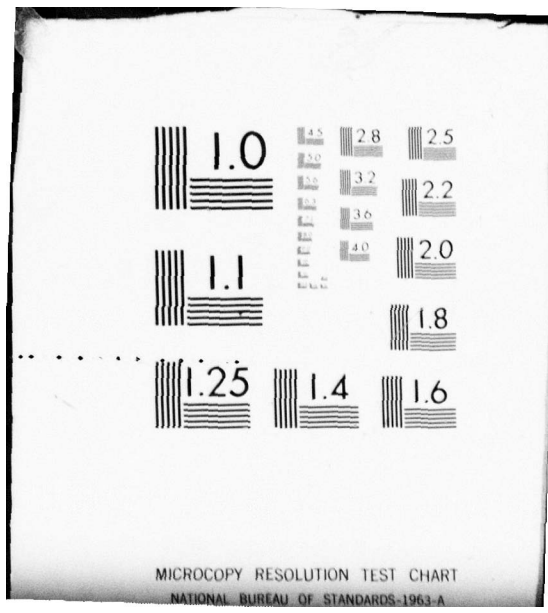

MICROCOPY RESOLUTION TEST CHART
NATIONAL BUREAU OF STANDARDS-1963-A

TABLE 4.3

BARRIER SYSTEMS -- PLANNING CHECKLIST

1. Assessment completed (see Section 2.4)?
Special considerations in assessment:
 - a. Slick area coverage and distribution of thicker patches of oil.
 - b. Locations where collecting the slick would be most desirable.
 - c. Rate of recoverable slick formation.
 - d. Wave conditions existing and projected.
 - e. Distance from support facilities.

2. Estimates made for:
 - a. Time available for cleanup to prevent resource damage?
 - b. Average rate of skimming required?
 - c. Number of systems necessary?
 - d. Number of receiving vessels needed?
 - e. Number of support vessels needed?

3. Information available on:
 - a. Location of suitable vessels and availability? Support gear?
 - b. Location of skimmers and barriers?
 - c. Location of suitable staging facilities?
 - d. Location of receiving barges or tankships, and availability? Tugs?
 - e. Location of disposal facilities for recovered oil?

4. Selections made for:
 - a. Vessels
 - . number?
 - . type?
 - . on-board equipment for launch assist? towing? other?

- b. Barriers
 - . length?
 - . sized for expected conditions?
 - . launching facilities? FDS sled?
- c. Skimmers
 - . type compatible with the approach variation to be used?
 - . launching facilities?
 - . support platforms for power units, control stations?
- d. Barge or other oil receivers
 - . towing vessels?
 - . auxiliary vessels for towing?
 - . oil-water separators?
 - . pumps or hoses?
 - . personnel protection aboard barge?
- e. Staging sites
 - . loading equipment?
 - . suitable for vessel draft?
- f. Recovered oil off-loading sites
 - . supplementary pumping equipment?
 - . tank trucks?
 - . storage tanks?
 - . disposal sites?
 - . debris handling?
- g. Surveillance methods
 - . aircraft?
 - . vessels?
- h. Personnel
 - . skimmer operating crews?
 - . surveillance crews?
 - . barge crews?
 - . supplementary crews for manning other support or towing vessels?
 - . other?

5. Plans made for:

- a. Chartering vessels?
- b. Outfitting vessels with support equipment (launching equipment, towing)?
- c. Delivery of skimming equipment and barriers?
- d. System assembly plan?
- e. Skimming plan (sweeping; mooring)?
- f. Surveillance patterns
- g. Receiver barge change-out?
- h. Documenting operations?
 - . operations log
 - . determining cleanup effectiveness?
 - . photography?
 - . updating slick location and configuration?
- i. Schedule for crew changes? Refueling?

6. Contingency plans prepared for:

- a. Booming of environmentally sensitive areas?
- b. Dispersant application if skimming system is ineffective?
- c. Use of VOSS or dedicated skimmers for escaping oil?
- d. Survival operations?

7. Safety considerations (see Appendix A)?

4.2.3

Approach: Dedicated Skimmer

A. Applications

1. Relatively thick slicks (1-5mm or greater) in windrows and patches, in sea condition up to State 3 or 4, depending on the design.
2. Where higher maneuverability than can be provided with large sweeping barrier systems is required.
3. Where fast response is required.

B. Description of Approach

1. The following components are required:
 - a. Dedicated skimming vessel: This is a skimming vessel designed specifically for skimming operations, and usually includes a fixed skimming mechanism, integral herding boom arms (to increase sweep width), recovered oil tankage, and support equipment (pumps, hoses, crew facilities, etc.). Other pollution control functions are sometimes included in the design to increase operating flexibility.

For rough weather use, a dedicated skimmer should have, in addition to the above, the following characteristics:

- . The vessel should provide a stable working platform for personnel. This implies a length of 160 feet or more for Sea State 4 or higher.
- . The skimming mechanism should have a high encounter rate with the oil. This implies a wide beam since herding boom arms become impractical in higher sea states.
- . The skimming mechanism should have minimum relative motion with the water. Non-surface-piercing concepts are more likely to be successful.

See Table 5.3 for characteristics of specific dedicated skimmer models.

- b. Bulk storage facilities for recovered oil/water mixtures.
 - c. Slick surveillance function for directing the vessel to new patch of oil (other vessels, aircraft).
2. Upon notification of a spill, the skimmer would be dispatched immediately to the vicinity of the spill.
 3. Surveillance vehicles (boat, aircraft) would proceed to the spill site to direct the skimmer to the thicker regions of the slick. Slick trajectory forecasting would be utilized also.
 4. Recovered oil would be periodically off-loaded to bulk storage facilities.

C. Variations on Basic Approach

1. Bulk storage can be provided in two ways:
 - a. At-sea transfers from onboard storage to large barges or tankers maintained in the vicinity of the spill (difficult operation in extreme weather), or direct to disposal facilities.
 - b. Transfers to shore-side tankage, via pipelines, tank trucks, or vacuum trucks brought to pier-side (time-consuming for remote spill).
2. In relatively calm conditions the skimmer could be utilized with long containment barriers attached to increase the sweep width (see Section 4.2.2).

D. Advantages

1. Provides a relatively small, self-contained, and highly maneuverable skimming system.
2. Rapid response. All required facilities are onboard and ready to operate.
3. Good availability. Priority is to emergency skimming.
4. Simple to mobilize because no equipment must be installed.

5. Crews are well trained in conducting skimming operations.
6. Skimming speeds from 1 to 3 knots may be feasible (special designs not available at this time may be capable of 6 to 10 knot skimming. Slick encounter rates may still be small, however, because of the limited width of the skimming mechanism and the inability to use herding boom arms).

E. Disadvantages

1. Almost all skimmers of this type located in U.S. waters are too small to be seaworthy in extreme weather operations.
2. Because of their specific designs, available skimmers are limited in the other work they can do, and therefore costs may be high.
3. Skimming mechanisms are generally fixed to the hull, and therefore have poor conformance with wave profiles in higher sea states.
4. Rigid sweeping boom arms typically present on many skimmers are not effective in higher wave conditions.
5. Onboard oil storage is generally limited, possibly limiting effectiveness in large spills.
6. Skimming rates are relatively low (compared to barrier systems).
7. Transit speeds may be lower than for other skimming methods because of the peculiar shape of the hull in many cases.

F. Special Problems/Techniques for Extreme Weather

1. Adequately sized and properly outfitted skimming vessels are mandatory. The skimming mechanism should be designed from the motions of the vessel, or else recovery and/or throughput efficiencies will be low (effective oil-water separators will help improve recovery efficiency).

2. If bulk oil storage is provided by a barge that has been towed to the vicinity of the spill, transfers from a dedicated skimmer may be more easily made in higher sea states if the barge is first taken in tow by the skimmer itself. Transfers can then be made by pumping the oil through a floating or suspended hose.
3. Downwind skimming may improve skimming efficiency, because the frequency of wave encounter is reduced and also skimmer vessel motions are minimized.

G. Planning Considerations

1. Time Plans: Figure 4.2 (Section 4.2.1) shows an example Time Plan for the case when a skimmer can be dispatched directly to a slick, and transfers of recovered oil to bulk storage are made to a large barge at sea. This example shows how the time in obtaining a bulk storage facility can limit the effectiveness of a rapid response technique such as a dedicated skimmer.
2. Decision Process: If dedicated skimmers are available, and are capable of operating (and surviving) in the environment at the spill site, they should be dispatched immediately whether or not other response techniques are also being considered for use. Figure 4.8 shows a brief outline of the more significant considerations in deciding to utilize sweeping barriers and skimmers, assuming sea conditions are satisfactory for the system under consideration.
3. Planning Checklist: See Table 4.4.

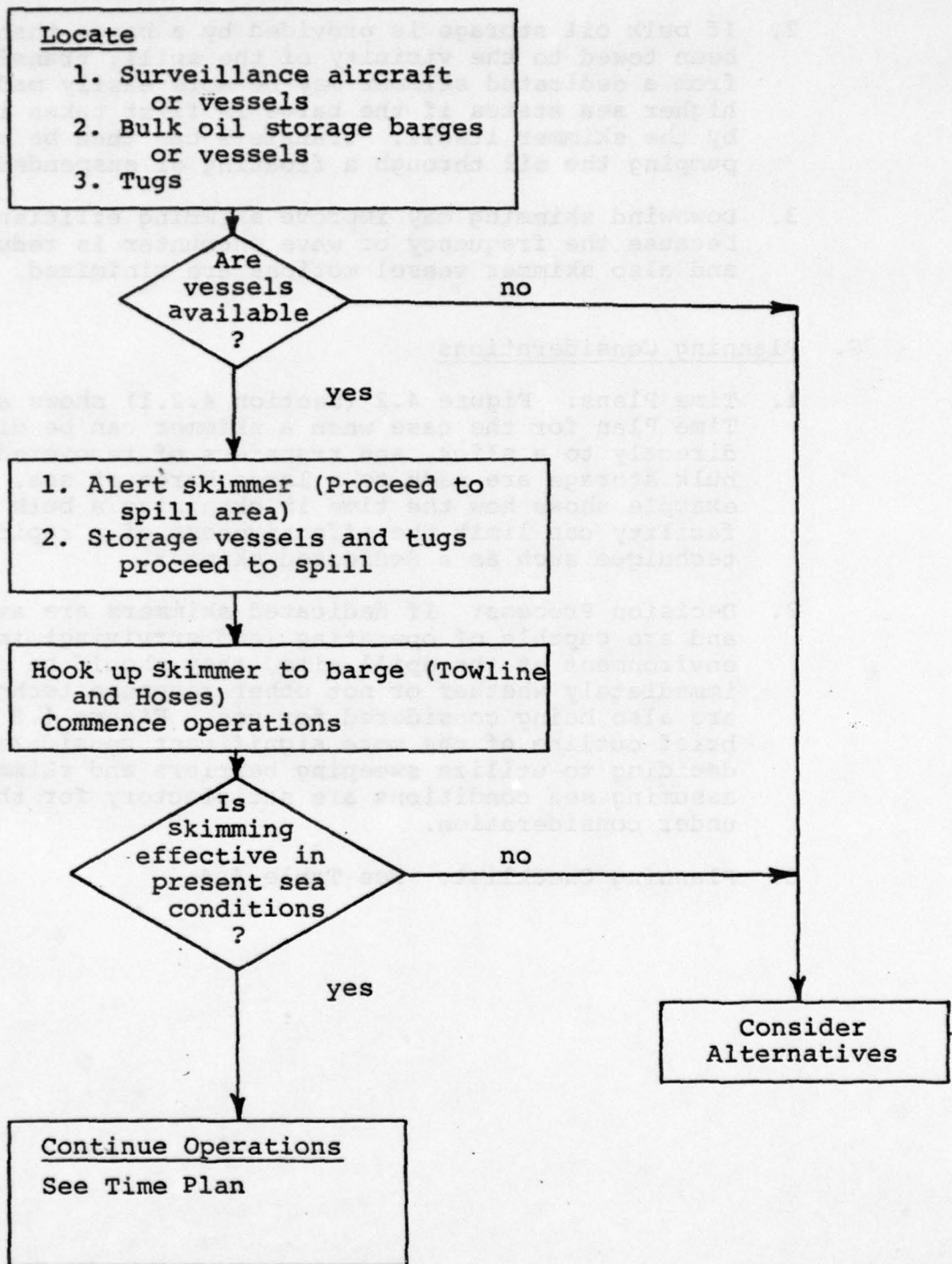

FIGURE 4.8 DEDICATED SKIMMER CONSIDERATIONS

TABLE 4.4

DEDICATED SKIMMER -- PLANNING CHECKLIST

1. Assessment completed (see Section 2.4)?
Special consideration in assessment:
 - a. Slick thickness (approximate, in patches and windrows)
 - b. Slick area coverage and distribution (windrows, patches, etc.).
 - c. Projected intercept areas and times of arrival of recoverable slick fractions at these areas.
 - d. Rate of recoverable slick formation.
 - e. Wave conditions.
 - f. Distance from port.
2. Estimates made for:
 - a. Time available for cleanup to prevent resource damage?
 - b. Average rate of skimming required?
 - c. Number of skimming systems required?
 - d. Number of receiving vessels needed?
3. Information available on:
 - a. Location of skimmer?
 - b. Location of bulk receivers and availability? Types?
 - c. Response times?
 - d. Location of disposal facilities for recovered oil?
4. Selections made for:
 - a. Skimmers?
 - b. Barge or other towable bulk storage receivers?
 - . pumps and/or hoses?
 - . personnel protection aboard barge?

- c. Recovered oil off-loading sites
 - . supplementary pumping equipment?
 - . tank trucks?
 - . storage tanks?
 - . disposal sites?
 - . debris handling?
 - d. Surveillance methods
 - . aircraft?
 - . vessels?
 - . special equipment for estimating slick thickness?
 - e. Personnel
 - . additional skimmer crews?
 - . surveillance crews?
 - . barge crews?
 - . other?
5. Plans made for:
- a. Contacting/mobilizing skimmers? Barges and tugs?
 - b. Arranging access to oil off-loading piers?
 - c. Skimming patterns?
 - d. Surveillance patterns?
 - e. Documenting operations?
 - . operations log
 - . determining cleanup effectiveness
 - . updating slick location and configuration
 - . photography
 - f. Schedule for refueling? Crew changes?
6. Contingency plans made for:
- a. Booming of environmentally sensitive areas?
 - b. Dispersant application if skimming is ineffective?
 - c. Survival operations?
7. Safety considerations (see Appendix A)?

4.2.4

Approach: Dispersants, Vessel Applied

A. Applications

1. For thin, wide-spread slicks where skimming is likely to be ineffective.
2. Where the combination of ecological, social, and economic damage caused by dispersed oil would be less than that caused by untreated oil.

B. Description of Approach

1. Permission must be obtained in accordance with Annex X of the National Contingency Plan.
2. The following components are required:
 - a. Bulk supplies of concentrated self-mixing dispersants. See Table 5.5 for a list of EPA accepted dispersants. Consult manufacturers for specific properties.
 - b. Dispersant storage and bulk transport system.
 - c. Spraying system to apply the dispersant, including pumps, hoses, spray booms, and support hardware. A typical setup is shown in Figure 4.9 based on the Warren Spring Laboratory (WSL) system (see Table 5.5 for comparative features of this and similar systems). This system consists of spray booms, approximately 15 feet long, which are suspended over each side of the vessel with a supporting and deploying framework. Towed breaker-boards (pallets) can be used to provide additional turbulence. A typical spraying system mounted on a vessel can spray a swath 60 feet wide at a speed of 8 knots. This will provide a coverage of approximately 67 acres/hour per vessel.
 - d. Vessels suitable for conducting spraying operation: General requirements for a vessel suitable for operations in rough weather are:
 - . 160 feet or longer (for Sea State 4 and greater).
 - . Capable of maneuvering in sea states from 4 to 6 (for extreme weather use).
 - . An open deck for mounting spray booms.
 - . On-board storage for dispersant (36,000 gallons would permit 30 hours of spraying at 20 gpm), or open deck space for portable tanks.

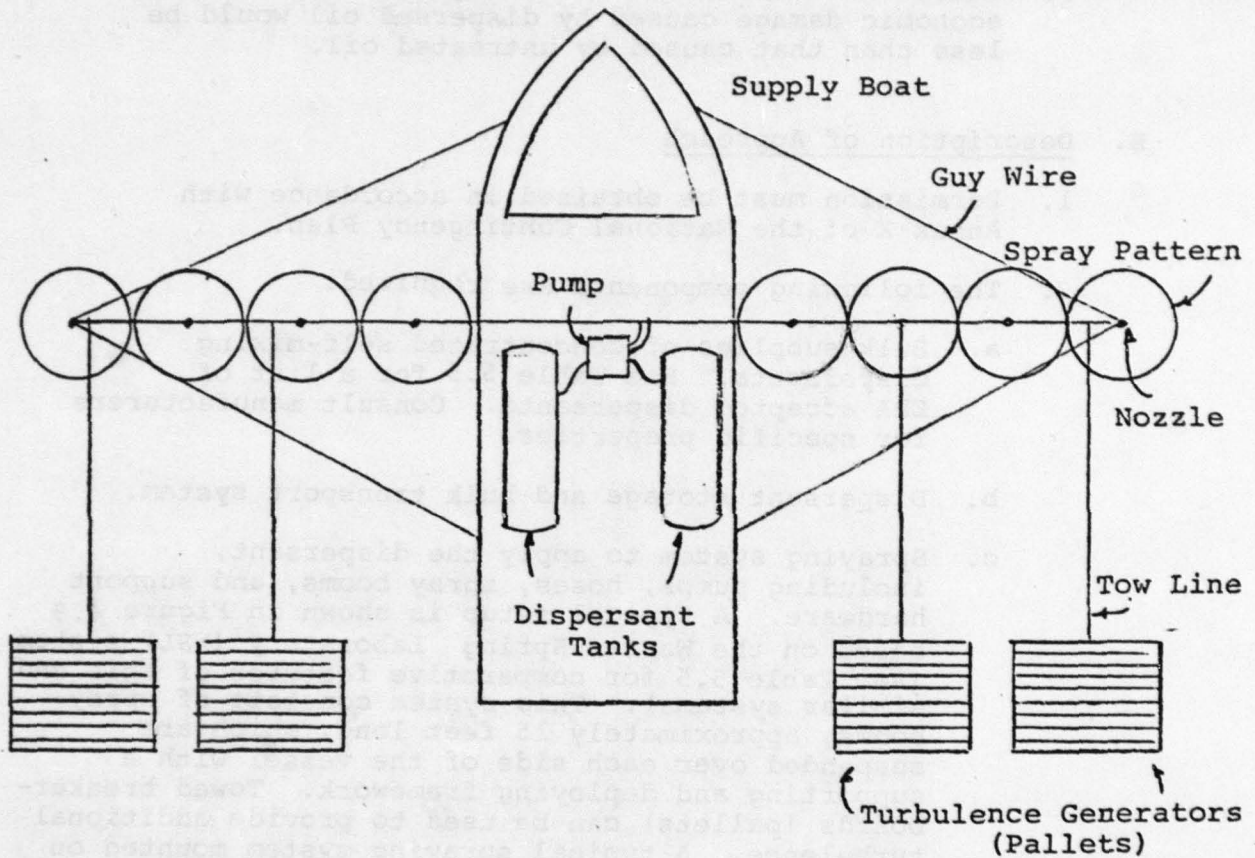

FIGURE 4.9 DISPERSANT SYSTEM - VESSEL APPROACH

Some vessels that might be suitable include buoy tenders, some Navy ships, fishing vessels and offshore supply boats.

- e. Surveillance system for directing spray boats to the slick (spotter aircraft or patrol boats)
3. Spray vessels would be obtained, outfitted for the operation, and dispatched to the staging area for dispersant loading.
4. Surveillance aircraft would be obtained and flown to the spill area as soon as possible. Slick surveillance might be supplemented by computer forecasting of oil trajectory. Vessel surveillance should be conducted, also.
5. Bulk dispersant supplies would be provided to the staging area for loading onto the spray boats.
6. Spray boats would conduct spraying operations as directed by surveillance vehicles and/or planned patterns. Resupply vessels as necessary.
7. Record results of operations.

C. Variations on Basic Approach

1. Bulk supplies of dispersant can be provided in several ways. Because of the large quantities that may be required careful planning is required for logistic support.
 - . Use tank trucks to bring dispersant from remote storage to dockside, and then fill on-board tanks
 - . Provide bulk storage in a barge, which is towed to the spill site for at-sea transfer to tanks onboard the spraying vessels (limited to less severe sea states)
 - . Provide dispersant in drums directly to the vessel (limited to small spills)

D. Advantages

1. Wind drift of slick is reduced if slick is dispersed.
2. Biodegradation of oil is enhanced.
3. Dispersed oil has less tendency to stick to solids.

4. Sea state capability is high compared to most skimming methods (less than aircraft application, however).
5. Can provide a quick-response capability if vessels are pre-adapted for spraying equipment.
6. Efficiencies can be better than for aircraft-applied dispersants because of slower and more controlled rate of application.

E. Disadvantages

1. Unless the OSC and the RRT have conducted the necessary contingency planning for the use of chemical agents, the U.S.E.P.A. approval process specified in Annex X of the National Contingency Plan may prove to be too time-consuming to permit the use of dispersants.
2. Long-term environmental effects of dispersants and dispersed oil are not well understood.
3. Bulk supplies of dispersants are not normally available, nor are the tankage and facilities that are required to handle them.
4. Dispersants are generally not as effective on thick slicks and viscous oils.
5. High costs of dispersants.
6. Vessels may not be available when needed, or may lack sufficient storage capacity for dispersants.
7. Generally a slower response potential than aerial techniques, depending on the amount of pre-adaptation of planes.

F. Special Problems/Techniques for Extreme Weather

1. The use of breaker boards (turbulence generators) will probably not be necessary in higher sea states, even when non-self-mixing dispersants (concentrates) are utilized.
2. If bulk dispersant supply is provided by a barge that has been towed to the vicinity of the spill, transfers to the spraying vessel may be more easily made in higher sea states if the barge is first taken in tow by the spraying vessel itself. Transfers can then be made by pumping the dispersant through a floating or suspended hose.

G. Planning Considerations

1. Time Plans: Figure 4.10 shows a representative Time Plan for a vessel-applied dispersant operation. This case is comparable to the aircraft-applied case, in which dispersant replenishment is provided by a barge towed to the site of the spill.

The principal time constraints, other than the approval (permission) process, will probably be in obtaining and preparing the spraying vessels for operation, and in replenishing the vessels if on-board capacities are limited. Several vessels will be required if the spill covers a wide area.

2. Decision Diagram: Assuming that application of dispersants by vessel is desirable, the general considerations to be made in determining if it is feasible are outlined in Figure 4.11. A decision guide for determining the desirability of using dispersants is being prepared by the EPA.
3. Planning Checklist: See Table 4.5.

2. Planning Considerations

1. Time Plans: Figure 4.10 shows a representative time plan for a vessel-applied dispersant operation. This case is comparable to the aircraft-applied case, in which dispersant requirement is provided by a barge towed to the site of the spill.

The principal time constraints, other than the approval process, will probably be in obtaining and preparing the spray-nozzle vessels for operation, and replenishing the vessels if on-board capacities are limited. Several vessels will be required if the spill covers a wide area.

2. Decision Diagram: Assuming that application of dispersant by vessel is desirable, the general considerations to be made in determining if it is feasible are outlined in Figure 4.11. A decision guide for determining the desirability of using dispersant is being prepared by the EPA.

3. Planning Checklist: See Table 4.8.

FIGURE 4.10 TIME PLANS FOR VESSEL-APPLIED DISPERSANT SYSTEM AND AIRCRAFT-APPLIED DISPERSANT SYSTEM

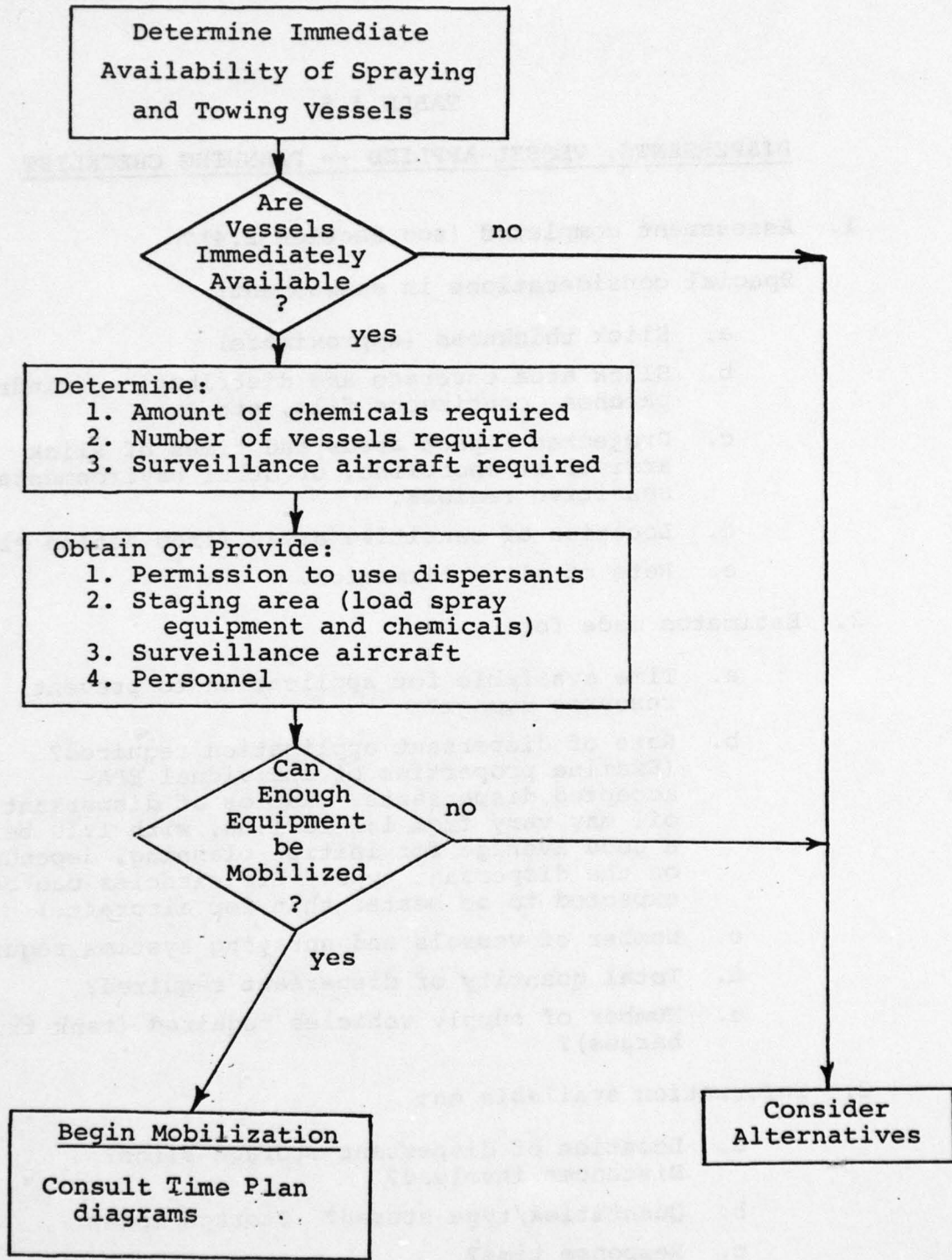

FIGURE 4.11 VESSEL APPLIED DISPERSANT SYSTEM CONSIDERATIONS

TABLE 4.5

DISPERSANTS, VESSEL-APPLIED -- PLANNING CHECKLIST

1. Assessment completed (see Section 2.4)?
Special considerations in assessment:
 - a. Slick thickness (approximate)
 - b. Slick area coverage and distribution (windrows, patches, continuous film, etc.)
 - c. Projected impact areas and times of slick arrival at shoreline, or other environmentally sensitive regions.
 - d. Location of sensitive areas (from Action Plans)
 - e. Rate of slick formation.

2. Estimates made for:
 - a. Time available for application to prevent resource damage?
 - b. Rate of dispersant application required? (Examine properties of individual EPA-- accepted dispersants. Ratios of dispersant to oil may vary from 1:1 to 1:50, with 1:10 being a good average for initial planning, depending on the dispersant type. Efficiencies can be expected to be better than for aircraft.)
 - c. Number of vessels and spraying systems required?
 - d. Total quantity of dispersant required?
 - e. Number of supply vehicles required (tank trucks, barges)?

3. Information available on:
 - a. Location of dispersant storage sites? Distances involved?
 - b. Quantities/type stored? Storage mode?
 - c. Response time?
 - d. Location of suitable docks? Other vessel loading facilities?

4. Selections made for:
 - a. Surveillance vehicles
 - . number and type - aircraft and/or vessels?
 - b. Spraying vessels
 - . number?
 - . type?
 - . storage capacity? Does extra storage capacity have to be installed?
 - c. Spraying equipment
 - . number?
 - . type? (see Figure 4.9 for representative type)
 - d. Staging locations
 - . docks/piers?
 - . airstrips (surveillance aircraft)
 - e. Logistics support
 - . tank trucks - capacity and number?
 - . barges - capacity and number?
 - f. Personnel requirements
 - . spraying system operators?
 - . barge/loading crews?
 - . spotters?
 - . other?
5. Plans made for:
 - a. Obtaining required equipment?
 - b. Pattern for applying dispersant on slick?
 - c. Schedule for resupply? Refueling? Crew changes?
 - d. Documenting operations?
 - . operations log
 - . mapping treated areas
 - . recording dosages
 - . updating slick location and configuration
 - . determining effectiveness of treatment (visual, water samples, infrared and other electronic techniques by CG surveillance planes)
 - . photography

- e. Obtaining required permission to apply dispersants (EPA)
 - . sampling oil
 - . determining effect of specific dispersant
6. Contingency plans prepared for:
 - a. Booming of environmentally sensitive areas?
 - b. Use of spraying aircraft?
 - c. Cleanup operations in case slick proves to be sufficiently unaffected by dispersant treatment?
 - d. Survival operation?
7. Safety consideration (see Appendix A)

4.2.5

Approach: Dispersants, Aircraft Applied

A. Applications

1. For thin, wide-spread slicks where application by vessel, or the use of skimmers, would be too slow or ineffective.
2. For the sea state range where vessel application (or skimming) is impractical but where a slick will continue to exist and pose a threat to the coastline or other environmentally sensitive area.
3. Where the combination of ecological, social and economic damage caused by dispersed oil would be less than that caused by untreated oil.

B. Description of Approach

1. Permission must be obtained in accordance with Annex X of the National Contingency Plan.
2. The following components are required:
 - a. Bulk supplies of concentrated self-mixing dispersant (see Table 5.5 for presently available types.).
 - b. Dispersant storage and bulk transport system.
 - c. Aircraft for spraying. Various types of aircraft can be used, but all must be specially outfitted for dispersant spraying, and preparations must be made well ahead of time to be able to obtain the aircraft on short notice.

Typical aircraft (commercially available) include:

- . Helicopters, utilizing an externally-slung crop spraying apparatus with special nozzles (for large droplet formation) -- low capacity (100 to 600 gallons)
- . Light planes equipped for crop spraying, with special nozzles (e.g. Piper Pawnee) -- low capacity (100 to 150 gallons).
- . DC-4 (C54) with special apparatus installed in plane - 2,500-3,000 gallon capacity.
- . DC-6 with special apparatus -- 2,500-3,000 gallon capacity.
- . Super Constellation with special apparatus - 3,500 gallon capacity.

- d. Surveillance aircraft equipped with oil detection equipment or spotters.
3. Spray planes would be obtained, prepared for operation and flown to the staging airfield.
4. Surveillance aircraft would be obtained and flown to the spill area as soon as possible. Slick surveillance might be supplemented by computer forecasting of oil trajectory.
5. Dispersants would be loaded onto tank trucks and transported to the staging airport.
6. Trucks and spray planes would continually shuttle dispersant from storage areas to the oil spill until complete dispersion of the oil had been effected, or until further application was no longer practical or effective.
7. Record results of operations.

C. Variations on Basic Approach

Supplies of dispersants can be provided in several ways. Careful planning is required to be able to obtain, deliver, and store the dispersants at convenient airports in the quantities needed for a particular spill. Possibilities include:

- Permanent field storage tanks of dispersant at preselected airports, with shuttle tank trucks for filling aircraft.
- Storage at other remote locations with a fleet of tank trucks for delivery direct to aircraft.
- Large capacity centralized barge storage that can be towed to nearby unloading site, with shuttle tank trucks for delivery to aircraft.

D. Advantages

1. Wind drift of slick is reduced if slick is dispersed.
2. Biodegradation of slick is enhanced.
3. Dispersed oil has less tendency to stick to solids.
4. Aircraft and personnel are not subject to sea conditions.
5. Provides rapid coverage of wide area, thin slicks.
6. Provides highest sea state operating capability.

E. Disadvantages

1. Unless the OSC and the RRT have conducted the necessary contingency planning for the use of chemical agents, the U.S.E.P.A. approval process specified in Annex X of the National Contingency Plan may prove to be too time-consuming to permit the use of dispersants.
2. Long-term environmental effects of dispersants and dispersed oil are not well understood.
3. Aircraft application equipment is not common and considerable planning and commitment will be required to ensure a rapid response.
4. Bulk supplies of self-mixing dispersants are not normally available, nor are the tankage and facilities that are required to handle them.
5. Self-mixing dispersants are not generally as effective on viscous oils or thick slicks.
6. Additional aircraft are required for spotting slicks.
7. High winds can cause inefficient dispersant application.
8. Limited capacity onboard aircraft for a single sortie.
9. High costs of dispersants.
10. Lower efficiencies than for vessel application because of less controllable application conditions (drift of sprayed dispersant due to wind, loss of dispersant to evaporation before contact with surface).

F. Special Problems/Techniques for Extreme Weather

1. Higher sea states and winds can make a slick more difficult to see and treat. Spotter aircraft and surface markers are especially important in tracking the untreated slick between sorties of the dispersant aircraft. Lower flight elevations and more path overlap would be helpful in improving application efficiency.
2. Natural dispersion by breaking waves and turbulence will occur at a more rapid rate as the sea state increases. At some point this process will become more effective than adding dispersant, and dispersant application can be terminated. As the weather subsides look for reappearance of oil on the surface.

G. Planning Considerations

1. **Time Plans:** Figure 4.10 (Section 4.2.4) shows a Time Plan for a large spill in which the bulk of the dispersant is contained in a large barge sited at a location 200 miles away. The application aircraft are assumed to initially fill their tanks from a land-based supply point located a considerable distance from the spill. After the bulk supply is towed to a nearby staging site, shuttle tank trucks refill the planes on a greatly accelerated schedule.

The times involved will depend on the type of aircraft, staging site, etc. Further details on flight times, loading times, etc., are included in references (6) and (7).

2. **Decision Diagram:** Assuming that application of dispersants by aircraft is desirable, the general considerations to be made in determining if it is feasible are outlined in Figure 4.12. A decision guide for determining the desirability of using dispersants is being prepared by the EPA.
3. **Planning Checklist:** See Table 4.6.

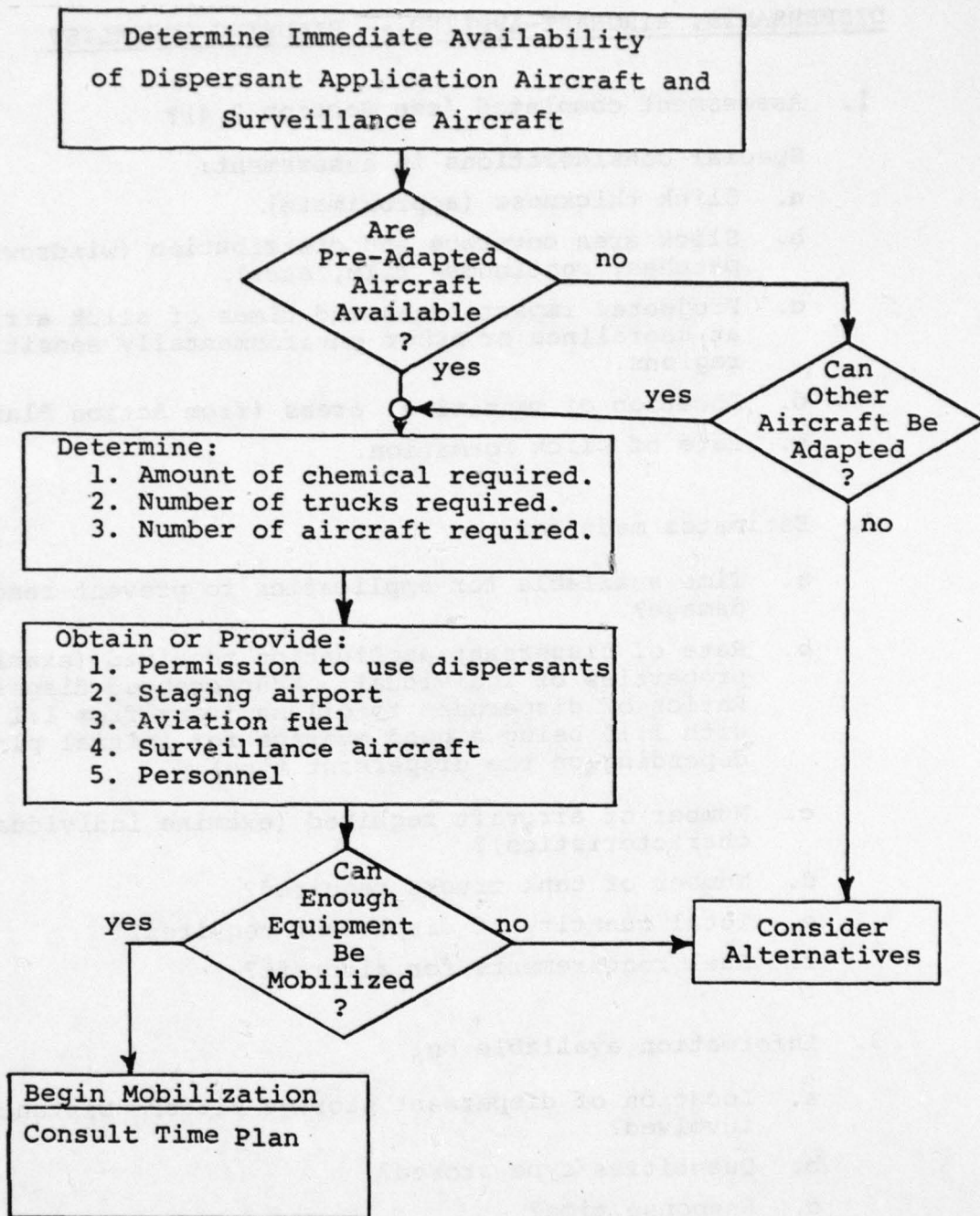

FIGURE 4.12 AIRCRAFT APPLIED DISPERSANT SYSTEM CONSIDERATIONS

TABLE 4.6

DISPERSANTS, AIRCRAFT-APPLIED -- PLANNING CHECKLIST

1. Assessment completed (see Section 2.4)?

Special considerations in assessment:

- a. Slick thickness (approximate).
- b. Slick area coverage and distribution (windrows, patches, continuous film, etc.).
- c. Projected impact areas and times of slick arrival at shorelines or other environmentally sensitive regions.
- d. Location of sensitive areas (from Action Plans).
- e. Rate of slick formation.

2. Estimates made for:

- a. Time available for application to prevent resource damage?
- b. Rate of dispersant application required (examine properties of individual EPA-accepted dispersants. Ratios of dispersant to oil may vary from 1:1 to 1:50, with 1:10 being a good average for initial planning, depending on the dispersant type).
- c. Number of aircraft required (examine individual characteristics)?
- d. Number of tank trucks required?
- e. Total quantity of dispersant required?
- f. Fuel requirements for aircraft?

3. Information available on:

- a. Location of dispersant storage sites? Distances involved?
- b. Quantities/type stored?
- c. Response time?
- d. Location of suitable airfields?
- e. Fuel sources?

4. Selections made for:

- a. Surveillance aircraft
 - . number?
 - . type?
- b. Dispersant application aircraft
 - . number?
 - . type?
 - . special equipment which must be installed?
 - . fuel quantity?
- c. Staging airport?
- d. Tank trucks
 - . number?
 - . type (dispersant or fuel)?
 - . capacity?
- e. Personnel required
 - . aircraft crews?
 - . aircraft ground crews?
 - . truck drivers?
 - . dispersant storage area pumping crew?
 - . supply personnel (food, etc.)?
- f. Vessels and crews (for surveillance and inspection, if weather permits)?

5. Plans made for:

- a. Obtaining required equipment?
- b. Pattern for applying dispersant on slick?
- c. Schedule for resupply? refueling? crew changes?
- d. Documenting operations?
 - . operations log
 - . mapping treated areas
 - . recording dosages
 - . updating slick location and configuration

- . determining effectiveness of treatment (visual, water samples, infrared or other electronic techniques by CG surveillance planes)
 - . photography
 - e. Obtaining required permission to apply dispersants (EPA)?
 - . sampling oil
 - . determining effect of specific dispersant
6. Contingency plans made for:
- a. Booming of environmentally sensitive areas?
 - b. Use of spraying vessels?
 - c. Cleanup operations in case slick proves to be sufficiently unaffected by dispersant treatment?
7. Safety considerations (See Appendix A)

4.2.6

Approach: Microbial Elimination of Oil Spills

A. Applications

1. Final cleanup of oil spills, after the bulk of the oil has been removed by other means.

B. Description of Approach

1. The following components are required:
 - a. Microbial agents: All microbial agents must be accepted by the U.S.E.P.A. in accordance with Annex X of the National Contingency Plan.
 - b. Application hardware: Conceivable application methods include:
 - . Aircraft: Conventional crop dusting planes could probably be adapted to apply powdered agents.
 - . Vessels: Vehicle-mounted crop dusting equipment could be used. If the microbes can be mixed with water, conventional dispersant spraying equipment can be used.
 - . Hand-operated machinery: For shoreline or small boat application (seeders, hand-casting, etc.)
2. Apply the agent to the slick in the presence of adequate aeration (implies application to relatively thin slicks).
3. As the assimilation process is very slow, booming may have to be employed to prevent shoreline contamination by offshore slicks.

C. Advantages

1. Achieves natural degradation of oil to non-toxic waste products.
2. Achieves cleanup at a faster rate than by depending on naturally occurring bacteria (e.g., where no cleanup effort has been applied at all).

3. Precludes the need for other cleanup equipment.
4. Rough seas can aid the assimilation process by helping in the oxygen transfer process.

D. Disadvantages

1. The processes for using microbes are undeveloped at this time. The technology is still basically in the R&D stage.
2. The process is very slow, at best. With adequate nutrients available (nitrogen, phosphorous) the limiting factor in the assimilation rate would be the oxygen transfer to the slick from the air. In a 30-knot wind, for example, it would take at least 2 to 3 days to assimilate a slick 125 microns thick. Lower wind speeds would result in less oxygen transfer and therefore slower assimilation rates.
3. Microbe costs would be high: At a 1:80 application ratio (10 lb. agent per acre, for a 125 micron slick), the projected microbe cost would be on the order of \$25,000,000 to clean up a 100,000-ton spill. Significant quantities of agents are not available at the present time. Therefore, the process will probably be limited to the treatment of small spills.
4. Shelf life of microbe mixtures is not unlimited.

E. Planning Considerations

Because techniques for large-scale application of microbial/nutrient agents have not been developed, no planning guidelines are presented. However, many of the considerations in applying dispersants by vessel or aircraft would probably be applicable.

4.2.7

Approach: Slick Burning

A. Applications

1. Burning thick slicks of low viscosity oil in calm water.

B. Description of Approach

1. The following components are required:
 - a. Igniters: Flame throwers, napalm, pyrotechnics, and burning projectiles have been used with varying degrees of success. Air drop, use of a device such as a tear-gas canister, rifle-launcher, or a catapult can be used for delivery of the igniter to the slick.
 - b. Wicking agents: A number of wicking agents have been tried, among them being straw, porous silica, porous ceramics, and a variety of buoy-type floating wicks. Special equipment may be required to apply certain types of agents to the slick. Blowers, hand spreading, or similar techniques can be used. It is possible that an oil-based slurry of agent could be applied, which would make spraying techniques usable, and would provide a pre-wetted wick for the slick.
 - c. Surveillance vehicles to locate suitable patches of oil.
 - d. Vessels to transport the wicking agents and igniters (unless air drops are used) to the spill.
 - e. Equipment to cleanup the unburned residue (booms, debris handling equipment).
2. The wicking agent is broadcast onto the slick and allowed to wet with the oil.
3. Igniters are dropped onto the slick to ignite the oil.
4. The unburned oil and debris are collected by booms, and cleaned up.

C. Variations on Basic Approach

1. Combustion of a thin slick is difficult to sustain because the heat is conducted away into the underlying water, and the wicking agent cannot easily "draw" oil from a thin slick. To maintain a thick pool of oil for more efficient burning, boom-like containment systems have been proposed. These are still in the development stage, however, and they have not yet been shown to be feasible for large-scale use.

D. Advantages

1. Under optimum conditions a large percentage of oil can be disposed of without skimming or dispersant application.
2. Burnable debris can be partially disposed of in-situ.

E. Disadvantages

1. Slick burning is usually difficult to sustain, even in calm water.
2. A large amount of residue is usually left over (a typical result from an application of wicking agent at 2 weight percent of an oil slick yields a residue of wicking agent and tarry solids comprising 15 weight percent of the weight of the slick). This residue constitutes an additional pollution problem to deal with.
3. The wicking agent must be replenished as it becomes plugged with tars and residues.
4. Viscous or weathered oils may not burn at all.
5. Does not work in waves.
6. The low bulk density of most wicking agents requires large volumes to be handled (on the order of 25 percent of the slick volume).

F. Planning Considerations

Because a successful technique for burning typical oil slicks has not been developed, no planning guidelines are presented.

5.0 RESPONSE EQUIPMENT AND SYSTEMS

This section provides more specific information and estimates on the operating characteristics and limitations of the specific equipment items that can be used in response operations. The topics include equipment for preventing pollution from vessels, skimming and dispersing equipment, and common equipment such as oil storage containers, work vessels, etc. Data sheets on the more commonly available items are also contained in Appendix H.

5.1 Portable Pumping Systems

Table 5.1 lists the principal characteristics for several portable pumping systems that have been designed for or can be used for cargo pumping. Most of them are available in the USA, including the Framo pumps. Several of these systems are available through oil pollution control contractors.

The pump rate comparison column in Table 5.1 shows the pumping rate at one head and for water only. The actual capacity of a given pumping system will depend on the oil viscosity, elevation difference between fluid levels (vessel tank to receiver), and hose length and diameter.

The size of the transfer hose will probably be dictated by availability. The length required will depend on the juxtaposition of the stranded vessel and the receiver. The hose pressure rating must also be considered, but ADAPTS pumps, for example, operate at relatively low (50 psi or lower) discharge pressures. A floating hose is preferred if the distance between vessels is so great that the hose must be in the water. Table 5.2 is an example of the handling capabilities for different size hoses of different lengths. This table is based on a flow of crude oil at 130⁰F and 340 S.S.U. entering the hose at 20 psi with no elevation difference between inlet and outlet fluid levels. Note that in many cases more than one pump discharge could be transported through a single hose. Other capacities can be determined

TABLE 5.1. EMERGENCY CARGO PUMPS

PUMP	ORIGIN	SYSTEM TYPE ¹	PUMP SIZE DIAMETER ² (in)	PUMP WEIGHT (lbs)	PUMP RATE COMPARISON ³ (gpm)	PRIME MOVER POWER (HP)	TOTAL SYSTEM WEIGHT ⁴ (lbs)
Frank Mohn AS Framo TK4 Framo TK5 Framo TK6	Norway	a a a	11.8 11.7 20.5	132 154 200	680 1,144 2,752	70 110 160	~ 3,650 ~ 2,575 ~ 2,620
Marlow Pumps Hydra Merse 6MFA-052	USA	a	13.5	?	~ 1,000	~ 60	?
Ocean Science & Engineering APTS	USA	a	11.0	225	980	43	1,325
Prosser 40 HP - Model 41000	USA	b	12.75	295	870	40	4,295
Seaward International STOPS	USA	a	10.0	200	1,030	43	1,300
Sloan 10-inch	USA	a	10.0	?	3,050	90	?
Thune-Eureka AS PUS 130 (CCN 100) PUS 500 (CCN 150)	Norway	a a	10.6 12.2	133 155	1,016 2,200	~ 90 ~ 150	2,330 3,100
US Coast Guard ADAPTS 10-inch, 2-stage ADAPTS 8-inch, 1 stage Stripper Pump	USA	a a a	10.5 12.5 12.1	455 264 290	920 900 733	43 43 43	1,755 1,564 1,590

Notes:

- ¹ System Type - a. Diesel-hydraulic
b. Diesel-electric

² Pump Size Diameter - overall pump diameter which determines whether pump will fit through 12.5-inch Butterworth fitting.

³ Pump Rate Comparison - the pumping rate in gallons per minute of water with 70 feet of head.

⁴ Total System Weight - the weight in pounds of the major system components (i.e., pump, power supply, and fluids (fuel and hydraulic oil)). Weight of hoses is not included.

for various viscosities by standard methods. Appendix E presents representative pumping capacities for the ADAPTS 10-inch pump as a function of hose length (Standard 6-inch ADAPTS hose) and viscosity.

TABLE 5.2 FLOW HANDLING CAPABILITIES OF VARIOUS
HOSE SIZES (GPM)

Hose Size	Hose Lengths			
	50'	100'	200'	300'
6"	3000	2300	1600	1300
8"	6500	4800	3300	2700
10"	11000	8000	5800	4700
12"	18000	13000	9000	7500

A new pumping system for more viscous oils is being procured by both the Coast Guard and SUPSALV. These units will have characteristics similar to the Framo TK5 or Prosser units.

Other pumping systems can also be used for oil or water (ballasting) pumping in certain cases:

- . Ship's pumps: Actual capacities can usually be obtained from the ship's master or crew. As a rule of thumb, the total pumping capacity of a large tanker is roughly 10 percent of the dead-weight tonnage capacity per hour.
- . Salvage pumps: These de-watering pumps are usually available through the USN SUPSALV or commercial salvage companies. Capacities of several representative sizes are presented in Appendix E.

- . Positive displacement pumps: These pumps are designed to pump viscous fluids, but are not generally available as complete portable pumping systems. Also, size and weight usually preclude utilizing these pumps as submersible units. Representative capacities as a function of oil viscosity are presented in Appendix E.

For viscous cargos, or for cargos that have cooled considerably as a result of tanker heating system failures, externally-supplied heating systems may be needed. Such systems are usually assembled specifically for particular salvage operations, and are not available off-the-shelf. SUPSALV has had experience in this area.

5.2 Skimmers

Table 5.3 shows a comparison of skimmers that have been designed for harbor or openwater use. Small open-water skimmers are not included. The system types in which the various skimming systems are generally used are indicated (see Table 4.1 for type description), as well as the basic skimming mechanism utilized (Appendix B). The sea state capabilities are for the most part based on engineering judgments, product literature, experience or observations on similar equipment. Factors considered in the sea state assessment include the following:

1. Performance in terms of processing rates, efficiency, etc.
2. Operational control of the integrated system
3. Personnel capabilities
4. Mobilization and setup of the system
5. Support logistics during operation
6. Reliability of equipment and systems
7. Long-term environmental effects
8. Survivability in higher sea states

In Appendix H, selected product literature is presented to provide additional information on equipment details.

TABLE 5.3. OIL SKIMMER CAPABILITIES

SKIMMER	ORIGIN	LENGTH (ft)	SYSTEM TYPE ¹	SKIMMING MECHANISM ²	SYSTEM OPERATION IN SEA STATES ³						SURVIVAL SEA STATE ⁴	OIL TREATMENT RATE COMPARISON ⁵ (gpm)	STORAGE CAPACITY ⁶ (gal)
					1	2	3	4	5	6			
AB Gustaf Terling Destroil DS 150 DS 210 DS 310	Sweden	~ 7 ~ 8 ~ 12	I.B.2 I.B.2 I.B.2	a a a	P	P	P				6+	70 ⁸ 230 ⁸ 450 ⁸	None None None
					F	F	F				3	100	500
					G						3	100	?
Bennett Pollution Controls Mark 3 Mark 4 Mark 6	USA	28 40 42	I.B.1 I.B.1 I.B.1	c,d c,d c,d	F	F-P	P				3	100	500
					G	F-P	P				3	100	?
					F	F-P	P				3	100	2,500
Bennex Euroskim System	Norway		I.A.1.c	b	G	G	F	P		6+	750	None	
Bridgestone S-II M L	Japan	38 68 92	I.B.1 I.B.1 I.B.1	d d d	F	P	P				3	130	1,300
					G	F	P				4	180	4,900
					G	G	F	P			6	260	16,000
Crisafulli Pump Co. Aqua Sweeper Small Large	USA	16 35	I.B.1 I.B.1	a a	F-P	P	P			3	100 ⁷	200	
					F	F-P	P				3	?	?
Centrifugal Systems Limpamar	USA	94	I.B.1	g	G	G	F	P		6	600	?	
Frank Mohn AS Framo	Norway	—	I.A.1.b	a,b	G	F	P			6+	500	None	
JBF Scientific Dip 2001 Dip 3003 Dip 5001	USA	13 38 68	I.B.2 I.B.1 I.B.1	d d d	F	P	P				6+	60 ⁷	150
					F	F-P	P				3	270 ⁷	4,000
					G	G	F	P			5	250 ⁷	10,000

¹⁻⁸See NOTES at end of TABLE 5.3.

TABLE 5.3. (Cont'd)

SKIMMER	ORIGIN	LENGTH (ft)	SYSTEM TYPE ¹	SKIMMING MECHANISM ²	SYSTEM OPERATION IN SEA STATES ³						SURVIVAL SEA STATE ⁴	OIL TREATMENT RATE COMPARISON ⁵ (gpm)	STORAGE CAPACITY ⁶ (gal)
					1	2	3	4	5	6			
Intex, Inc. Vortex Oil Drinker VX-100 VX-200	USA	17	I.A.1.a	e	F	P	P				3	~ 30	None
		25	I.A.1.a	e	G	F	P				4	~ 250	None
Lockheed Clean Sweep Model R2002 Model R2003 (raft) OMORS	USA	27	I.A.1.a	b	F	P	P				3	50	None
		29	I.B.1	b	G	F	P				3	150	400
		23	I.A.1.a	b	G	G	F	P			4-5	750	None
LPI Corporation OSED 33	USA	33	I.B.1	d	F	P	P			3	160	2,000	
MARCO Pollution Control Class I Class III Class V Class VII Class X Class XI	USA	24	I.B.1	c	F	P	P				3	120	440
		58	I.B.1	c	G	F	P				4-5	400 ⁷	3,800
		36	I.A.2.b	c	G	F	F-P	P			4-5	200	1,700
		48	I.A.2.b	c	G	F	F-P	P			4-5	200	3,400
		37	I.A.2.b	c	G	F	F-P	P			4-5	400	None
		—	I.B.2	c	F	F-P	P				6+	200 ⁸	None
Mitsubishi Heavy Industries Seiryu Maru	Japan	311	I.B.1	d,e	G	G	F	P		6+	1,200	~390,000	
Mitsui Ocean Development MIPOS-S MIPOS-10 MIPOS-C-15 MIPOS-B-17	Japan	20	I.B.2	d	G	F	P			3	440	None	
		33	I.B.1	d	G	F	P			3	170	750	
		49	I.B.1	d	G	F	P			5	300	~ 4,000	
		57	I.B.1	d	G	F	P			3	390	~25,000	

1-See NOTES at end of TABLE 5.3.

TABLE 5.3. (Cont'd)

SKIMMER	ORIGIN	LENGTH (ft)	SYSTEM TYPE ¹	SKIMMING MECHANISM ²	SYSTEM OPERATION IN SEA STATES ³						SURVIVAL SEA STATE ⁴	OIL TREATMENT RATE COMPARISON ⁵ (gpm)	STORAGE CAPACITY ⁶ (gal)
					1	2	3	4	5	6			
Neyrtec Cyclonet 050 070 100 120 150	France	—	I.B.2 I.B.2 I.B.2 I.B.2 I.B.2	e e e e e	F	P	P	P	P	P	6+	130 ⁹	None
					G	P	P	P	P	P	6+	260 ⁹	None
					G	G	F	P	P	P	6+	310 ⁹	None
					G	G	F	P	P	P	6+	460 ⁹	None
					G	G	F	P	P	P	6+	520 ⁹	None
Offshore Devices USCG Skimming Barrier	USA	—	I.A.2.a	a	G	G-F	F	F-P	P	5	400	None	
					F	P	P			3	150 ⁷	None	
011 Harvester Mark III	USA	33	I.B.1	e	F	P	P			3	50	2,000	
011 Mop, Inc. Dynamic Skimmer ZRV	USA	38	I.B.1	g	F	P	P			3	45	?	
Quality Marsh Industries Skimjet	USA	16	I.B.1	a	F	P	P			3	200 ¹⁰	None	
Shell Oil Co. SOCK (25' wide)	USA	—	I.B.2	f	G	F	P	P		6+			
Seaward International Spiltrol Huskey	USA	25	I.B.1	f	F	P	P			3	50 ⁷	1,176	
		42	I.A.2.b	a	G	F	F-P	P		4-5	350	None	
Vikoma Seaskimmer	England	11	I.A.1.b	b	G	G	F	P		6+	400	None	

1-19 See NOTES at end of TABLE 5.3.

TABLE 5.3. (Cont'd)

Notes:

- ¹ System Type - Refer to Table 4.1, Spill Mitigation and Cleanup, for the type of system that the Skimmer is to be used with.
- ² Skimming Mechanism - See Appendix B for further descriptions.
 - a. Weir skimmer
 - b. Oleophilic disks
 - c. Surface-piercing oleophilic belt
 - d. Dynamic inclined plane
 - e. Cyclonic separator
 - f. SOCK skimmer
 - g. Zero-relative-velocity (ZRV) sorbent mechanism
- ³ Key is: G = Good, F = Fair; P = Poor. These ratings indicate estimated performance of the system as a whole, including barriers, support, etc., when the Skimmer is used with the System Type indicated. A blank suggests that no operation should be attempted in this sea state.
- ⁴ Survival of the entire system, including barriers, etc., is implied. Where equipment can be easily recovered aboard seaworthy vessels, high ratings are given.
- ⁵ Oil treatment rate - These rates are estimated based on system capacities, slick properties, and operating efficiencies, assuming the following conditions:
 - a. Relatively calm seas, implying "Good" steady-state operating conditions -- rates can be expected to drop off to very low values in the "Poor" operating condition.
 - b. Slick is assumed to be 3 mm thick and uniform, viscosity 400 cs (partially weathered crude).
 - c. Encounter rate is 1 knot for barrier systems (Type I.A) & 2 knots for direct-acting skimmers (Type I.B).
 - d. Slick encounter width is the barrier opening (400 feet) for barrier systems (Type I.A) & device opening (including small sweep booms, if part of the device) for direct-acting skimmers (Type I.B).
 - e. For barrier systems (Type I.A), at least 2 inches of oil thickening is assumed in the apex.
 - f. For barrier systems, either the Coast Guard OMOCS or another appropriate type of open-water barrier is used.
- ⁶ Storage capacity implies integral storage contained on the Skimmer, and not any external bulk storage that may be required.
- ⁷ Utilizing integral sweep arms to increase encounter rate.
- ⁸ Short lengths of herding barrier utilized in VOSS application.
- ⁹ Sweep width includes half the beam of a 30-foot-beam vessel, assuming oil is not pushed away from the hull at low speeds.
- ¹⁰ Still under development. Performance may be optimistic in the higher sea states.

5.3 Containment Booms

Table 5.4 presents the characteristics of various containment booms. This table divides the booms into offshore, outer harbor, and inner harbor types. The division has been made somewhat arbitrarily according to the overall height, with booms up to 24 inches high classified as inner harbor types, 24 to 36 inches generally classified as outer harbor types, and 36 inch and over classified as offshore types. Some overlap can be expected in actual performance capabilities, as indicated by the estimated performance/operation ratings in various sea conditions.

The performance/operation rating provides a separate indication of a boom's oil containment ability, which is primarily a function of freeboard, draft, wave conformance, and stability, and its operatability, which is a function of its deployment, handling, control, durability, strength, and general "seaworthiness" characteristics. A low rating in the operation category indicates that at least one of the boom's operational characteristics is objectionable, and the boom should be carefully considered for use in that sea state. For example, the Navy OOC boom is durable and strong, but it is very heavy and difficult to deploy and handle, and requires a long lead time to prepare for operation; it therefore receives a low rating in all sea states.

The operational ratings are also based on relative operatability in the sea states indicated; i.e. the Coast Guard OWOCS is a good choice for a Sea State 3 operation because it can be deployed rapidly and is generally designed for these conditions. It is not necessarily a good choice for Sea State 1, however, because there are other booms that are much easier to handle and deploy in these conditions, and that will give performance as good as the OWOCS; the OWOCS therefore receives a lower rating in this sea state.

TABLE 5.4. OIL BOOM CAPABILITIES — Offshore Booms¹

OIL BOOM	ORIGIN	OVERALL HEIGHT (ft)	FREEBOARD (ft)	DRAFT (ft)	BOOM TYPE ²	PERFORMANCE/OPERATION IN SEA STATES ³						SURVIVAL SEA STATE ⁴	TENSILE STRENGTH ⁵ (lbs)	STORAGE VOLUME (ft ³ /100ft)	WEIGHT (lbs/100ft)
						1	2	3	4	5	6				
AB Sjuntorp Coastal Type Open Sea Type	Sweden	38	16	22	D.4.b.2.A	G/G	F/G	P/G				4			377
		63	27	36	D.4.b.2.A	G/F	G/G	F/G	P/F			4			538
American Marine Supamax	USA	36	12	24	A.1.a.3.A	G/G	F/G	P/G			4	30,000	116	290	
Bennett Pollution Controls Zoom Boom Series 18 Model 24 Series 24 Model 24 Viking Series	USA	42	16	26	A.2.b.1.A	G/G	F/G	P/G			4	16,500	260	328	
		48	22	26	A.2.b.1.A	G/G	G/G	F/G	P/F		4	25,000	380	475	
		120	60	60	A.2.b.1.A	G/F	G/F	G/G	F/G	P/F	5				
Bennex MOFI Boom XL-8 X-F7 X-F11 XL-F11	Norway	~ 66	39	~ 27	A.3.b.2.C	G/F	G/G	F/G	P/F		5	44,100	56	872	
		~ 60	32	~ 28	A.3.b.2.C	G/F	G/G	F/G	P/F		6	132,300	60	1,408	
		~ 78	40	~ 38	A.3.b.2.C	G/F	G/G	F/G	F-P/G	P/F	6	132,300	78	2,012	
		~ 118	40	~ 78	A.3.b.2.C	G/P	G/F	G/G	F/G	P/F	6	132,300	82	2,347	
Goodyear Sea Sentry 12-24 Navy Boom (1/2" Chain)	USA	36	12	24	C.2.b.1.A	G/G	F/G	P/G			3	10,600		850	
		36	12	24	C.2.b.1.A	G/F	F/G	P/G			4	18,000	128	~ 1,280	
Hurum Enterprises Flexy II, 36" Flexy High Seas, 72"	USA	36	12	24	D.1.a.2.B	F/G	P/F	P/P			3		72	300	
		72	24	48	D.1.2.b.c.1.B	G/F	F/F	P/P			4			800	
Kepner Plastics Fabricators Standard Sea Curtains AHDZ203020FF AHDZ3030620FF SHQ18230F SJYHM243636DF Sea Tender Booms ⁶ SHQ222G5VF	USA	51	17	34	A.2.a.1.A	G/F	F/G	P/G			5	104,000		1,800	
		68	26	42	A.2.a.1.A	G/F	F/G	P/G			5	169,000		1,900	
		41	15	26	A.2.a.b.1.A	G/G	G/G	F/G	P/F		5	95,000		360	
		61	21	40	A.2.a.b.1.A	G/G	G/G	F/G	P/F		5	120,000		1,200	
		36	12	24	A.2.a.1.B	G/F	F/G	P/F			4	15,000		360	

¹—See NOTES at end of TABLE 5.4.

TABLE 5.4. (Cont'd) — Offshore Booms¹

OIL BOOM	ORIGIN	OVERALL HEIGHT (ft)	FREEBOARD (ft)	DRAFT (ft)	BOOM TYPE ²	PERFORMANCE/OPERATION IN SEA STATES ¹						SURVIVAL SEA STATE ⁴	TENSILE STRENGTH ⁵ (lbs)	STORAGE VOLUME (ft ³ /100ft)	HEIGHT (lbs/100ft)
						1	2	3	4	5	6				
Kleber Bataer 3	France	51	21	30	D.3.a or b. 1.A	G/F	G/G	F/G	P/F			4	—	—	771
Norsk Oljelense A/S Purse Seine Oil Boom	Norway	—	—	—	A.3.a.b.2.C							—	—	—	—
Offshore Devices Coast Guard High Seas Boom (CJOC)	USA	48	21	27	C.4.b.2.B	G/F	G/G	F/G	P/F			5	~ 50,000	132	1,600
Oil Spill Containment Corp Offence, 36" Offence, 48"	USA	36 48	18 24	18 24	E.5.a.5.B E.5.a.5.B	G/G G/G	F/G G-F/G	P/G P/G				5 5	64,800 96,000	145 185	525 840
Slickbar Heavy Duty Mark 5	USA	36	12	24	C.1.a.2.A	G/G	F/G	P/G				3	10,000	—	—
Trelleborg Troilboom Universal Giant	Sweden	41 59	16 20	25 39	C.4.a.2.B C.4.a.2.B	G/G G/F	G/G G/G	F/G G/G	P/F F/G			4 5	27,500 44,880	— —	314 1,250
Uniroyal Sealboom, 72"	USA	72	24	48	E.5.a.2.B	G/P	G/G	F/G	P/F			5	45,600	—	960
US Navy Navy OOC Type Oil Boom	USA	72	24	48	C.1.c.1.B	G/P	G/P	F/P	P/P			5	~ 48,000	1,440	6,850
Vikoma Seaboom	England	44	27	17	E.5.b.4.D	G/G	G/G	G/G	F/G			5	55,000	~ 25	152
Welsh Oil-Tech ⁷ General Purpose Boom Class 3	USA	36	13	23	A.2.a.b.1.A	G/G	F/G	P/G				4	—	—	—
Whittaker Expandi-Oil Boom Sea Boom #4300	USA	43	18	25	A.2.b.1.A	G/G	G/G	F/G	P/F			4	16,500	19	353

¹—See NOTES at end of TABLE 5.4.

TABLE 5.4. (Cont'd) — Outer Harbor Booms¹

OIL BOOM	ORIGIN	OVERALL HEIGHT (in)	FREEBOARD (in)	DRAFT (in)	BOOM TYPE ²	PERFORMANCE/OPERATION IN SEA STATES ³						SURVIVAL SEA STATE ⁴	TENSILE STRENGTH ⁵ (lbs)	STORAGE VOLUME (ft ³ /100ft)	WEIGHT (lbs/100ft)
						1	2	3	4	5	6				
AB Sjuntorp Port & Lake Type	Sweden	28	12	16	D.4.b.2.A	G/G	F/G	P/G				4	—	—	269
American Marine Airmax	USA	24	12	12	A.2.b.1.A	G/G	F/G	P/F				4	20,000	10	—
Bennett Pollution Controls Permanent Harbor Boom	USA	30	12	18	E.5.a.2.A	F/F	P/F	P/P				4	35,000	—	1,200
30 in		36	12	24	E.5.a.2.A	G/F	F/F	P/P				5	40,000	—	1,400
Navy Boom ⁶		36	12	24	A.1.a.2.B	G/G	F/G	P/F				3	—	—	—
Type 11 Class 1 Zoom Boom		30	10	20	A.2.b.1.A	G/G	F/G	P/G				3	5,700	125	180
Series 12 Model 18															
B.F. Goodrich Seaboom 36 PFX	USA	36	12	24	E.5.a.2.B	F/F	P/F					3	10,000	—	1,050
Seaboom 36 PFS		36	12	24	E.5.b.2.4.B	F/F	P/F					3	10,000	—	1,950
Environetics Boa Boom	USA	36	12	24	E.5.b.1.A	G/G	F/G	P/F				3	—	~7	—
Boa Boom II		27	9	18	E.5.a.1.A	G/G	F/G	P/F				3	—	~45	—
Goodyear Sea Sentry 9-18	USA	27	9	18	C.2.b.1.A	G/G	F/G	P/G				3	10,600	—	503
Hurum Enterprises Flexy II, 24"	USA	24	8	16	D.1.a.2.B	F/G	P/F					3	—	48	260
Keprer Plastics Fabricators Standard Sea Curtains	USA	30	12	18	A.2.a.1.A	G/G	F/G	P/F				5	69,000	—	880
AHD141608FF		30	12	18	A.2.a.b.1.A	G/G	F/G	P/G				5	69,000	—	220
Compatible Sea Curtain SHD1416DF		24	8	16	A.2.a.1.B	F/G	P/G					3	10,000	—	290
Sea Tender Boom ⁸ BHD81408IF															

¹—See NOTES at end of TABLE 5.4.

TABLE 5.4. (Cont'd) — Outer Harbor Booms¹

OIL BOOM	ORIGIN	OVERALL HEIGHT (ft)	FREEBOARD (ft)	DRAFT (ft)	BOOM TYPE ²	PERFORMANCE/OPERATION IN SEA STATES ³						SURVIVAL SEA STATE ⁴	TENSILE STRENGTH ⁵ (lbs)	STORAGE VOLUME (ft ³ /100ft)	WEIGHT (lbs/100ft)
						1	2	3	4	5	6				
Kleber Acorn III Balear 2	France	32	12	20	C.4.a.1.A D.3.4.a or b, 1.A	G/G	F/G	P/G				4	—	—	1,005
		36	15	21		G/G	F/G	P/G				4	—	—	536
Metropolitan Petroleum MP-Boom-Heavy Duty	USA	36	12	24	A.1.a.2.A	G/G	F/G	P/G				4	35,000	93	360
Oil Spill Containment Corp Oilfence, 24"	USA	24	12	12	E.5.a.5.B	G/G	F/G	P/G				5	48,000	70	375
Seaward International ¹ Sea Fence Outer Harbor	USA	28	12	16	A.3.a.2.B	G/G	F/G	P/G				4	15,000	63	400
Trelleborg Troilboom-Bantam	Sweden	30	10	20	C.4.a.2.B	G/G	F/G	P/G				4	27,500	—	314
Uniroyal Sealboom 1-Ply, 36" 2-Ply, 36"	USA	36	12	24	E.5.a.2.B E.5.a.2.8	F/G	P/F					4	20,000	—	300
		36	12	24		F/G	P/F					5	48,000	—	580
Welsh Oil-Tech ⁷ General Purpose Boom Class 2	USA	24	9	15	A.2.a.b.1.A	F/G	P/G					3	—	—	—
Whittaker Expandi-Oil Boom Harbor Boom #3000	USA	30	11	19	A.2.b.1.A	G/G	F/G	P/G				3	5,700	11	156

¹—See NOTES at end of TABLE 5.4.

TABLE 5.4. (Cont'd) — Inner Harbor Booms¹

OIL BOOM	ORIGIN	OVERALL HEIGHT (in)	FREEBOARD (in)	DRAFT (in)	BOOM TYPE ²	PERFORMANCE/OPERATION IN SEA STATES ³						SURVIVAL SEA STATE ⁴	TENSTILE STRENGTH ⁵ (lbs)	STORAGE VOLUME (ft ³ /100ft)	WEIGHT (lbs/100ft)
						1	2	3	4	5	6				
Acme Products O.K. Corral-standard	USA	18	6	12	E.5.a.1.A	P/G							50	150	
American Marine Simplex Optimax	USA	18 19	6 7	12 12	A.2.a.1.A D.1.2.a.1.A	P/G F/G	P/G						33 33	170 200	
Bennett Pollution Controls Inshore Booms	USA	12 18 18 24 24 36	5 6 8 12	7 12 16 24	A.1.a.2.A A.1.a.2.B A.1.a.2.B A.1.a.2.B	P/G P/G P/G F/G	P/G P/G P/G						17 25 33 50	212 222 238 346	
-Permanent Harbor Boom		24	10	14	E.5.a.2.A	F/G	P/F						—	1,000	
Navy Boom ⁶		13	5	8	A.1.a.2.B	P/G							—	—	
Type 1 Class 1		24	8	16	A.1.a.2.B	F/G	P/G						—	—	
Type 1 Class 2		18	6	12	A.1.a.2.A	P/G							—	200	
General Purpose Boom		18	6	12	A.1.a.2.A	P/G							—	275	
River Boom		18	6	12	A.1.a.2.A	P/G							—	—	
Zoom Boom		19	6	13	A.2.b.1.A	P/G							4.6	90	
Series 7 Model 12															
Bennex HOPI - HL-30	Norway	~ 20	12	~ 8	A.3.b.2.C	F/G	P/G						—	400	
B.F. Goodrich Seaboom 18 PFX	USA	18	6	12	E.5.a.2.B	P/G							—	800	
Cascade Industries River Boom	USA	~ 9	3	~ 6	B.2.a.1.A	P/G							—	—	
Harbor Boom		~ 22	6	~ 16	E.5.a.1.A	P/G							—	—	
Boom		~ 24	8	~ 16	E.5.a.1.A	F/G	P/G						—	—	
Crowley Environmental Services CES Petro Barrier		24	11	13	A.2.a.1.B	F/G	P/G						128	460	

¹—See NOTES at end of TABLE 5.4.

TABLE 5.4. (Cont'd) — Inner Harbor Booms¹

OIL BOOM	ORIGIN	OVERALL HEIGHT (ft)	FREEBOARD (ft)	DRAFT (ft)	BOOM TYPE ²	PERFORMANCE/OPERATION IN SEA STATES ³						SURVIVAL SEA STATE ⁴	TENSILE STRENGTH ⁵ (lbs)	STORAGE VOLUME (ft ³ /100ft)	HEIGHT (lbs/100ft)
						1	2	3	4	5	6				
Envronetics Boa Boom III	USA	15	5	10	E.5.a.1.A	P/G						2	~ 15	—	
Hurum Enterprises Flexy II, 14"	USA	14	5	9	D.1.a.2.B	P/G						2	16	100	
Flexy II, 18"		18	6	12	D.1.a.2.B	P/G						2	20	150	
Kepner Plastics Fabricators Standard Sea Curtains	USA	13	4	9	A.2.a.1.A	P/G						4	—	100	
		18	5	13	A.2.a.1.A	P/G						4	—	120	
		20	7	13	A.2.a.1.A	F/G	P/G					4	—	300	
		20	7	13	A.2.a.b.1.A	F/G	P/G					4	—	180	
		12	4	8	A.2.a.1.B	P/G						2	—	140	
Kleber Balear 1	France	24	10	14	D.3.a.a.or b. 1.A	F/G	P/G				3	—	335		
Metropolitan Petroleum MP-Boom-Standard	USA	18	6	12	A.1.a.2.A	P/G					2	30	230		
O11 Spill Containment Corp Oilfence, 18"	USA	18	9	9	E.5.a.5.B	F/G	P/G				4	30	260		
Seaward International ⁶ Sea Fence Inner Harbor	USA	18	8	10	A.3.a.2.B	F/G	P/G				3	47	260		
Slickbar Multi-purpose Mark 9 Beach Boom Mark 6	USA	18	6	12	C.1.a.2.A	F/G	P/G				2	—	—		
		18	6	12	C.1.a.2.A	F/G	P/G				2	—	~ 275		
Uniroyal Sealboom, 18" Mini	USA	18	6	12	E.5.a.2.B	P/G					4	—	150		
Welsh Oil-Tech ⁷ General Purpose Boom Class 1	USA	12	5	7	A.2.a.b.1.A	P/G					2	—	—		

¹—See NOTES at end of TABLE 5.4.

TABLE 5.4. (Cont'd)

Notes:

¹ Definitions: Offshore Booms - booms of 36" or greater overall height which are generally designed for open water use.
 Outer Harbor Booms - booms of 24"-36" overall height generally designed for use in sheltered waters with some chop.
 Inner Harbor Booms - booms of 24" or less overall height generally designed for use in calm sheltered waters.

² Boom Type: Tension Means . Tension Material . Flotation Type . Ballast Means . Boom Geometry

Tension Means	Tension Material	Flotation Type	Ballast Means	Boom Geometry
A. Bottom	1. Cable	a. Foam	1. Chain	A. Top float (generally cylindrical) with skirt
B. Top	2. Chain	b. Pneumatic	2. Weights	B. Fence and skirt
C. Middle	3. Kevlar	c. Hard floats	3. Cable	C. Purse seine
D. Top & Bottom	4. Synthetic	x. Unknown	4. Water	D. Cylindrical float with cylindrical skirt
E. No Tension member	5. Rope		5. No ballast	X. Unknown
X. Unknown	5. Fabric		x. Unknown	
	x. Unknown			

³ Performance/Operation in Sea States: Key is G = Good; F = Fair; P = Poor. The first rating is estimated performance of each oil boom when used within the accepted limits for all oil booms (low speeds of about 1 knot). Performance is defined as the ability to contain a high percentage of the surrounded oil. Good performance implies good wave conformance, good stability, little washover, etc. The second rating is estimated overall operation of the boom. Such factors as: speed of deployment or response, durability, ease of handling and control, "seaworthiness", cleanup, etc. are considered. A blank in a sea state suggests that operation should not be attempted.

⁴ Survival limit of the oil boom is for the deployed state but freely streaming (not in a "U" configuration). Oil loss does not constitute failure.

⁵ Tensile strength - ultimate strength of tension member or fabric in case of boom without tension member. A factor of safety of about 4 should be applied to these values to determine the useful working load.

⁶ Built to M11-B-28617A (YD)

⁷ Built to M11-B-28617C (YD)

⁸ Built to M11-B-28627B (YD)

⁹ Built to M11-B-29186 (YD)

The booms can be used for protecting desired areas (passive responses) or for slick containment to aid in skimming (active responses). Booms that are being considered for use with specific skimmers should have similar sea state operating capabilities (See Table 5.3).

Details on some of the more desirable booms are given in Appendix H.

Towing forces depend on the tow speed (generally less than 1 knot for effective containment), boom length, mouth opening, draft, and sea conditions. Various references can be used to estimate towing forces. ⁽⁵⁾ For reference, a 612-foot long OWOCS (27-inch draft) towed with a 400-foot mouth opening at 1 knot in a Sea State 3 would have an average towing force (per vessel) of approximately 6,400 pounds. This is easily handled by most buoy tenders, offshore supply boats, offshore fishing boats, and similar vessels.

5.4 Dispersant Application Systems

Table 5.5 shows comparative features of general dispersant application systems. The Warren Spring, Clean Atlantic, and Exxon system consist of spray booms and pumps, and can be mounted on any suitably sized vessel such as an offshore supply vessel, small tank ship, or similar vessel. The sea state rating assumes that vessels of these types are used to support the system during operation. The Water Witch and Combat Cat are specific vessel types with dispersant gear integrated into the design.

The Globe Air, Inc., system is not one particular system, as several different aircraft can be equipped with the spraying gear. The treatment rate listed in the table represents one of the largest capacity systems. Almost any crop spraying aircraft, including helicopters, can also be equipped with suitable tankage, pumps, and nozzles for spraying dispersant. Smaller aircraft can only provide limited treatment rates, however.

TABLE 5.5. DISPERSANT SYSTEM CAPABILITIES

DISPERSANT SYSTEM*	ORIGIN	LENGTH (ft)	SYSTEM TYPE ¹	SYSTEM OPERATION IN SEA STATES ⁵						SURVIVAL SEA STATE ³	OIL TREATMENT RATE COMPARISON ⁴ (gpm)	STORAGE CAPACITY ⁵ (gal)
				1	2	3	4	5	6			
Warren Spring (vessel) ⁷	England		II.A.2	G	G	G	G	F	P	6+	48	Drums
Clean Atlantic (vessel)	USA		II.A.2	G	G	G	G	F	P	6+	500	500
Globe Air, Inc. (aircraft)	USA		II.A.1	G	G	G	G	G	F	6+	≤ 8,000 ⁸	≤ 4,000
Combat Cat ⁷	England	20	II.A.2	G	F	P				3	~ 14	~ 200
Water Witch ⁷	England	17	II.A.2	G	F	P				3	48	200
Exxon (vessel)	USA		II.A.2	G	G	G	G	F	P	6+	300	Drums

NOTES:

- ¹ System Type - Refer to Table 4.1, Spill Mitigation and Cleanup, for the type of system that the Dispersant System is to be used with.
- ² Key is: G = Good; F = Fair; P = Poor. These ratings indicate estimated performance of the system as a whole, including barriers, support, etc., when the Dispersant System is used with the System Type indicated. A blank suggests that no operation should be attempted in this sea state.
- ³ Survival of the entire system, including barriers, etc., is implied. Where equipment can be easily recovered aboard seaworthy vessels, high ratings are given.
- ⁴ Oil treatment rate - These rates are estimated based on system capabilities, slick properties, and operating efficiencies, assuming the following conditions:
 - a. Relatively calm seas, implying "Good" steady-state operating conditions -- rates can be expected to drop off to very low values in the "Poor" operating condition.
 - b. Slick is assumed to be <1 mm thick and uniform, viscosity 400 cs (partially weathered crude).
 - c. Encounter rate is >4 knots.
 - d. Slick encounter width is spray boom width.
 - e. A nominal treatment ratio of 1 part concentrated dispersant to 20 parts oil is assumed.
- ⁵ Storage capacity implies integral storage contained on the Dispersant System, and not any external bulk storage that may be required.
- ⁶ High rate of treatment is for only 10 minutes spraying per round trip. Various sizes of aircraft may be utilized.
- ⁷ Breaker boards required.
- ⁸ Dispersants with properties presently accepted by the EPA include the following:

a. Atlantic-Pacific Oil Dispersant (GFC Chemical Co.) b. BP 1100 HD (BP Oil Limited) c. BP 1100 X (BP Oil Limited) d. Cold Clean (Adair Equipment Co.)	e. Conco Dispersant K (Continental Chemical Co.) f. Corexit 9527 (Exxon Chemical Co.) g. Gold Crew (ARA Chem) h. Sea Master NS-555 (Whale Chemical Co.)
-----------------------------------------------------------------------------------------------------------------------------------------------------------------	------------------------------------------------------------------------------------------------------------------------------------------------------------------

5.5 Oil Receiving Vessels

Separate oil receiving vessels are required for off-loading operations and for certain skimming operations. The characteristics of several types of receiving vessels are shown in Table 5.6.

Tankers are available in a wide range of sizes, and the size needed for a particular operation will depend on several factors, including:

- . quantity of fluid to be off-loaded or received
- . available water depth (limits vessel draft)
- . maneuverability required (may need tug assist)
- . facilities available for transferring cargo to shore
- . sea conditions

Tankers have an advantage in that they are self-propelled, but they are not normally available on a quick response basis. Although only military tankers are listed in Table 5.6, they do represent characteristics similar to many smaller commercial tankers.

Steel petroleum barges are fairly common in many areas, and are available in a wide range of sizes. Barges to be used offshore must be Coast Guard certificated for offshore use. Most barges are not equipped with pumps. If it is desired to utilize a barge tank for oil-water separation, special pumps and piping must be installed. Also, shelter must be provided if operating personnel are required on board (large barges sometimes have shelter already installed).

Barges have a disadvantage in that they must be towed. An adequately sized tug must be obtained to tow the barge, unless the barge is used as an integral part of the system, such as in a barrier-skimmer system where the barge is towed by one of these components. Usually, a satisfactory tug can be provided by the barge leasor. In rough seas careful control must be maintained over the barge, and maneuverability will be limited. Because of low freeboard, the full barge storage capacity can probably not be utilized.

TABLE 5.6. TYPICAL OIL RECEIVING VESSELS

VESSEL	ORIGIN	LENGTH OVERALL ¹ (ft)	LOADED DISPLACEMENT (tons)	LOADED DRAFT ² (ft)	LIQUID CAPACITY ³ (barrels)	SPEED ⁵ (knots)
TANKERS⁴						
US Navy Military Sealift Command	USA	672	~ 48,500	36	310,000	16.5
"Falcon" Class (AO)		587	~ 35,100	34	220,000	16
"Sealift" Class (AO)		523	22,380	30	134,000	15
"Suamico" Class (AO) (T-2)		325	6,000	19	30,000	10
"Peconic" Class (AOG)						
STEEL PETROLEUM BARGES						
Representative Sizes						
		430		22	150,000	
		300		23	105,000	
		250		12	49,508	
		195		9	14,057	
		150		~ 7	10,000	
		60		~ 4	1,142	
TOWABLE FLEXIBLE TANKS						
Dunlop Dracone	England	26 - 298		2 - 9	28 - 6,914	10
Unifroyal Oil Salvage Container	USA	? - 140		? - 6	119 - 5,000	5
Firestone Fabritank	USA	15 - 44		5 - 7.5	119 - 1,190	? ¹
Kepner Sea Container	USA	15 - 66		3 - 9	14 - 333	10
SuperFlexit	France	? - 85		? ²	63 - 756	? ³
Caiman		30		2.5	38	3
Flexiclone				3	17 - 34	? ⁴
Zodiac Diodon Tank	USA	10.5 - 21				

NOTES:

- ¹ Length Overall. For Towable Flexible Tanks, the range of lengths is given (smallest and largest tank).
- ² Loaded Draft. For Towable Flexible Tanks, the range of draft is given for smallest and largest tanks. Where draft was not available, tank height was used -- draft may be somewhat less.
- ³ Liquid Capacity. For Towable Flexible Tanks, the range of capacity for each type is given (smallest and largest tank).
- ⁴ The tankers listed represent typical size ranges that might be considered, whether they be military or commercial vessels.
- ⁵ Speed. For Towable Flexible Tanks, is the approximate safe maximum tow speed (knots) when full.

Towed flexible tanks (rubber or plastic) are limited to relatively small sizes, but they can provide a rapid response capability for off-loading leaking tanks and other small-scale operations. These tanks can be transported to the casualty by a vessel in a rolled or folded condition, and then deployed (partial inflation may be required). After filling they must be towed back to port for unloading. However, it is conceivable that several containers could be filled, moored near the casualty site, and then towed to port all at one time. The large Caiman tanks can be self-propelled (outboard motors) for use around harbors.

Make-shift storage capacity can be installed on certain vessels, such as by temporarily installing deck tankage or pillow tanks. However, this approach may be unsatisfactory because of stability reduction on the vessel, or because of the generally limited capacity that can be installed. For an application such as dispersant storage, such methods may be necessary.

5.6 Work Vessels

Work vessels are used in all phases of pollution response operations. Applications include towing of booms and receiving vessels, VOSS or dispersant system support, personnel transport, and equipment delivery and deployment. A wide variety of vessels are available, although obtaining the best vessel when it is needed can be difficult if preplanning has not been adequate. Table 5.7 shows the characteristics of several vessels representing the types of work boats that might be utilized in different types of offshore pollution response operations.

Vessels of over 160 feet in length would generally be able to operate or survive in all weather conditions in which response operations might be carried out (up to Sea State 5 or 6). Smaller vessels may be useful for limited tasks, but vessel

TABLE 5.7. TYPICAL WORKBOATS

VESSEL	ORIGIN	TYPE ¹	LENGTH OVERALL (ft)	DRAFT (ft)	MAX SPEED (kts)	POWER ² (hp)	BOW THRUSTER (yes/no)	DECK CARGO ³ (tons)	LIQUID CARGO ⁴ (tons)	VESSEL APPLICATION ⁵
MILITARY										
Coast Guard "Balsam" Class (MLB) "Red" Class (MLM) 110' Harbor Tug (MYTM)	USA	g	180	13	15	1200	yes			A,C
		h	157	6	13	1800	yes			A,C
		d	110	11	11	1000	no			B
U.S. Navy Fleet Tugs (ATF) Large Harbor Tug (YTB) "Diver" Class (ARS)	USA	c	205	16	15	3000	no			B
		d	109	14	?	2000	no			B
		f	214	13	15	2440	no			B,C
COMMERCIAL										
Smit-Lloyd B.V. 100 Class	Netherlands	a,c	210	17	15.5	7500	yes	500	600	A,B,C,F
Seahorse "North Seahorse" "Auster" "Coastal Seahorse" "Canadian Seahorse"	USA	a,c	190	15	14	5750	yes	450	~ 450	A,B,C,F
		a	165	10	11	1500	no	563	~ 850	C,F
		b	130	9	8.5	800	no	343	~ 370	C,F
		e	90	6	25	1600	no	20	—	D
Jackson Marine "Godfather" "Mister Lou" "Judie"	USA	c	149	~ 18	?	7400	yes	—	—	A,B
		c	100	~ 10	?	2550	no	—	—	B
		d	65	~ 6	?	700	no	—	—	A
MonArk Boat Co. 4014 V 21' "Little Giant"	USA	f	40	4	?	700	no	—	—	E
		f	21	1	?	175	no	—	—	E
Raider Marine Raider SRV-1034	USA	f	34	3	~ 30	230	no	5	—	E

TABLE 5.7. (Cont'd)

- NOTES:**
- ¹ Type - a. Offshore Supply Boat c. Ocean Tug e. Crew Boat g. Offshore Buoy-tender i. Salvage Ship
 - b. Coastal Supply Boat d. Coastal Tug f. Utility Boat h. Coastal Buoy-tender
 - ² Power - Either shaft or brake horsepower. A rough rule of thumb for bollard pull is 1 ton of pull per 100 HP. This is not true for higher speed vessels.
 - ³ Deck Cargo - This limit may not be possible if full liquid cargo is on board.
 - ⁴ Liquid Cargo - Built-in tankage for this amount. This limit may not be possible if deck is fully loaded.
 - ⁵ Vessel Application - A. Low speed towing, 1 kt or less with good control (e.g., boom towing)
 - B. Heavy towing, straight line (e.g., receiving barge towing)
 - C. VOS support, 1-3 kts with good control
 - D. Personnel transport, high speed
 - E. Equipment deployment (e.g., boom, skimmer, etc.)
 - F. Dispersant application, 4-8 knots

motions can become severe in the higher sea states causing personnel and vessel distress (seasickness, injury, water on the deck, slamming, loss of steering control at low speeds, etc.).

Selection of a vessel for a particular task or mission involves determination of:

Vessel characteristics:

- . size and space available (for equipment installation, operating deck space, etc.)
- . speed/steering capability (CP propellers, thrusters, etc.)
- . towing capability (winches, bitts, etc.)
- . equipment handling capability (A-frame, davits, hoists, winches)
- . liquid storage capacity (tankage, room for temporary tanks, stability)
- . limitations on types of liquids that can be stored (petroleum cargos, dispersants, others)
- . personnel facilities (other than for normal crew)
- . general "seaworthiness" (length, draft, freeboard, stability, etc.)
- . communications/navigation capabilities
- . duration time on-site
- . ability to operate in hazardous atmospheres

Availability:

- . owner/operator
- . prior commitments of vessel
- . time to charter and move to staging area
- . willingness of owner/operator to cooperate
- . liability commitments

Other floating platforms can also be used for special tasks. For example, the Coast Guard FDS sled can be used for transporting barriers, skimmers, and other equipment to be used in the water, directly to the casualty site. Barges can also be used to support tasks requiring a large deck area, unusually heavy equipment, or other purposes.

6.0 REFERENCES

1. Beach, March, Ruetenik, and Davis, "Investigation of Extreme Weather Oil Pollution Response Capabilities--Final Report," DOT-CG-80372-A, USCG Report CG-D-68-78, Seaward International, Inc., Sept. 15, 1978.
2. Myers, Holm, and McAllister, Handbook of Ocean and Underwater Engineering, McGraw-Hill Book Co., New York, 1969, pp. 11-98.
3. "Environmental Conditions With Specified Geographical Regions--Offshore East and West Coasts of the United States and in the Gulf of Mexico--Final Report," U.S. Department of Commerce, NOAA Environmental Data Service, April, 1973.
4. Naval Ship's Technical Manual, Chapter 079, Volume 2, Damage Control, NAVSEA 0901-LP-079-0020, July 1, 1977.
5. Milgram, J.H., "Physical Requirements for Oil Pollution Control Barriers," Proceedings of Joint Conference on Prevention and Control of Oil Spills, March 13-15, 1973, Washington, D.C., pp. 375-381.
6. Lindblom, G.P., "Logistic Planning for Oil Spill Chemical Use," Proceedings of 1979 Oil Spill Conference, March 19-22, 1979, L.A., Calif., pp. 453-458.
7. Hildebrand, P.B., Allen, A.A., and Ross, C.W., "The Feasibility of Oil Spill Dispersant Application in the Southern Beaufort Sea," EPS-3-EC-77-16, Minister of Supply and Services Canada, Sept., 1977.
8. Peril at Sea - Guidance to Masters, Oil Companies International Marine Forum, 12th Floor, Portland House, Stag Place, London, SW1E-5BH, 1979.
9. Christensen, R.D., and Motherway, D.L., Survey Update on Damage Assessment and State of the Art of Patching and Plugging Systems, Hazardous Chemicals Discharge Prevention and Reduction Project (794151), Interim Report, Dec., 1978, U.S. Coast Guard R&D Center, Groton, CT.

APPENDIX A

Safety Considerations

In order to evaluate the various hazards and related safety precautions when carrying out the response scenarios of this study, a brief discussion of each appropriate hazard category has been included in this Appendix. A description of the hazard is followed by a discussion of the precautions, preparations, and equipment needed to effectively deal with them. The descriptions are not intended as a complete safety manual, but rather as a means of highlighting possible problem areas and the general approach to controlling them. The user should make reference to appropriate reference material (CHRIS and other safety manuals) for detailed guidance concerning hazard abatement.

The hazard summaries are preceded by a matrix of Response Methods vs. Hazards, which points out the summaries appropriate to the response method utilized. The matrix serves as a quick guide to the areas of primary concern as well as a checklist of suggested safety considerations. While the matrix has been made to be complete, the possibility of hazards outside the indicated areas does exist. Supervisory personnel should remain aware of any unusual environmental or procedural factors which may create unusual safety hazards and be prepared to deal with them.

Details of Safety Hazards

Fire Hazards

1. From Explosives: These materials are those that may generate highly flammable or explosive mixtures with air, and can be easily ignited by sparks or hot surfaces. Included in this category are gases, cryogenic liquids, liquids with a flash point below ambient temperature, dusts, and mists of flammable liquids. Gasoline, naphtha, LNG, LPG, and light hydrocarbons (pentane to octane) are some common materials with this volatility.

HAZARDS

RESPONSE METHODS

Casualty Vessels

Jettisoning
 Ballasting &
 Stabilizing
 Off-Loading
 In-Situ Burning
 Cutting ship Apart

Oil Slicks

Aircraft Dispersants
 Vessel Dispersants
 Vessel of Opportunity
 Skimming
 Dedicated Skimmer
 Skimming Barrier
 Barrier & Skimmer

FIRE			EXPLOSION			HEALTH		ENVIRON- MENTAL	
From Explosives	From Combustibles	From Burnable Materials	From Shock Sensitive Materials	From Detonatable Materials	From Reactive Materials	From Toxicity	From Hypothermia	From Cold Climate	From Ship Motion
	✓	✓			✓		✓	✓	✓
	✓	✓			✓		✓	✓	✓
	✓	✓			✓		✓	✓	✓
✓	✓	✓	✓	✓	✓	✓	✓	✓	✓
✓	✓	✓	✓	✓	✓	✓	✓	✓	✓
					✓	✓	✓	✓	
	✓	✓			✓	✓	✓	✓	✓
	✓	✓					✓	✓	✓
	✓	✓					✓	✓	✓
	✓	✓					✓	✓	✓
	✓	✓					✓	✓	✓

Extreme caution must be taken in the presence of these materials. Electrical equipment must be of the appropriate class, tools must be non-sparking, smoking is prohibited, and all other sources of ignition must be excluded.

Fire extinguishers and other fire treatment systems will generally be ineffective with these materials, although they should be available to extinguish potential ignition sources.

2. From Combustibles: These materials include those that may be ignited under ambient temperature conditions. Such materials include liquids with a flash point less than 15°C above ambient temperature, solid materials which are fibrous, shredded, or granular, and solid materials which contain available oxygen. Kerosene, light crude oils, and #1 fuel oils are in this category.

Sources of ignition, including open flames, smoking materials, overheated equipment, engine exhausts, and electrical short circuits, must be avoided.

Fire extinguishing systems should be located near operating personnel and near the combustible materials. They should be of a type appropriate to the fire hazard. Personnel should be trained in the use and care of this equipment.

3. From Burnable Materials: These materials include those that can be ignited if moderately heated, including liquids with a flash point from 15 to 70°C above ambient temperature, and other materials which can be readily burned in air such as wood, paper, and asphalt. Most fuel oils and crude oils are in this range of flash point.

Open flames must be avoided, smoking allowed only in areas clear of such materials, and care taken to avoid excessive heat in the vicinity.

Fire extinguishers or charge hoses should be located at several points throughout the operating area. Precautions should be taken for avoidance of smoke inhalation should fires occur.

Explosion Hazards

1. From Shock Sensitive Materials: These materials include those that are capable of exploding by themselves, at ambient temperatures and pressures. They may be sensitive to mechanical and/or thermal shock. Blasting caps, detonators, etc., are in this group. Only personnel trained in the safe handling and use of explosives should be permitted in the area.

2. From Detonatable Materials: These materials include those that are capable of exploding if exposed to an initiating source, or if heated when confined. All blasting materials and pyrotechnics are detonatable in this manner.

Possible initiating sources or sources of heat must be kept away from these materials. Means for cooling, such as water deluge hoses, should be charged and located nearby. Personnel should be instructed in the necessary precautions to be taken, and only personnel trained in the use and handling of explosives should work with these materials.

3. From Reactive Materials: These materials include those from which explosive materials or violent reactions may occur upon contact with water or with other common materials (e.g. diborane and water or nitrates and oil). Care must be taken to avoid hazardous mixtures of these materials. The primary precaution is thorough education of personnel working with them.

Personal Health Hazards

1. From Toxicity: Materials handled can cause serious injury or death upon exposure to personnel, through toxic or corrosive properties.

Reference should be made to the hazard of each specific material for detailed information on the type and degree of hazard and the precautionary measures to be taken. The CHRIS manual or other appropriate reference sources should be consulted.

2. From Hypothermia: Exposure to extreme cold and/or high winds could result in hypothermia (extreme loss of body heat) or frostbite (damage to exposed skin from exposure to cold).

Adequate protective clothing combined with limitation of exposure to cold will minimize the risk of hypothermia or frostbite. Keeping clothing dry, providing shelter from wind, and insuring awareness of the difficulty of detecting these conditions before serious damage has been done are additional necessary precautions that must be taken.

Environmental Hazards

1. From Cold Climates: Low temperature may cause hazards due to snow, sleet, or icing of decks and equipment. (See also Personal Health - Item 2.) This hazard is compounded when ship motions are present (see 2 below). Precautions to be taken include provision of life-lines and hand-holds throughout the operating area. Footgear with non-slip soles will also make icing hazards less severe. Personnel should wear Personal Flotation Devices at all times.
2. From Ship Motion: Winds and accompanying heavy seas may cause ship motion, making operations hazardous. When combined with rain, snow, or ice this hazard is much more severe.

Ship motions can also cause motion sickness which can be hazardous due to loss of ability to think clearly as well as significantly reducing operator efficiency. Equipment handling and deployment are difficult and hazardous in these conditions.

Life-lines and hand-holds should be provided throughout the operating area. Personal Flotation Devices should be worn at all times. Medication for prevention of motion sickness should be dispensed under the supervision of a Medical Officer. Extreme care should be taken when moving equipment; correct rigging procedures are even more important than usual when heavy seas and ship motions are present.

APPENDIX B

Skimming Mechanisms

Brief descriptions of typical skimming mechanisms and the ways in which they can be utilized are given in the following sections.

Weir Skimmers: Several skimmers utilize a weir to separate a thickened oil layer from the underlying water. Wave conformance of the weir lip is extremely critical, and this mechanism is best utilized in skimming barriers where the support framework (in this case, the barrier itself) conforms well to the surface in higher sea states.

Oleophilic Disks: This skimming mechanism utilizes disks that rotate in a thickened pool of oil, lifting the oil from the surface where it can be scraped off the disks and recovered. Oil booms are required to thicken the oil sufficiently. Various hull-shaped or other floating devices are used to support the disk arrays and associated machinery.

Surface-Piercing Oleophilic Belt: In this mechanism, an endless, rotating, porous (foam) belt dips into a thickened pool of oil and removes oil by sorbent action, while water drains back to the surface. This mechanism requires a heavy supporting structure, and is usually employed on a vessel system.

Dynamic Inclined Plane: In this case, a non-porous rotating conveyor-type belt is not used to collect oil directly, but only directs the oil beneath the skimmer to a collection chamber.

Cyclonic Separator: This mechanism employs a cyclonic separator attached to the side of a support ship, and uses the momentum of the water flowing past the ship to separate the oil from the water encountered by the device. Other devices

have separate mechanisms for generating a vortex, but the stability of the vortex is a problem in waves.

SOCK Skimmer: The SOCK concept is to have a covered oil boom arranged on each side of the vessel. A wide opening is maintained by a rigid framework, which also provides attachment points for the tow lines. The cover on the top of the boom has several oil suction ports to remove the oil as it collects near the back of the SOCK, which also serves as a wave damper.

Zero-Relative-Velocity (ZRV) Sorbent Mechanisms: ZRV systems can operate at high forward speeds (3 knots), because the sorbent lies "stationary" on the water for a brief period. These systems fall into three classes -- loose sorbent (foam cubes or thin slabs) continuous rope (MOP) sorbent, and continuous belt (foam or other material) sorbent. Each of these concepts solves the wave conformance problem with a different degree of wave compliance, with loose sorbents giving potentially the best conformance and belt sorbents the least. Upon removal of the sorbent foam from the oil slick, the sorbent is squeezed out and the oil is collected. The sorbent is then returned to the water for further oil collection.

APPENDIX C

Stability Calculations

The basic calculations for determining the stability of a vessel in a sound or damaged state are included in this Appendix. Sample problems are provided as examples of the calculation method. The following areas are treated.

1. Computing GM
2. Computing BM (Metacentric radius)
3. Shifting weight in vertical direction (Trans. Stab.)
4. Shifting weight in athwartships direction (Trans. Stab.)
5. Adding or subtracting new weight (Trans. Stab.)
6. Computing angle of list
7. Loose water, free surface effect
8. Free surface, with free communication
9. Moving weights in longitudinal plane
10. Computing change of Hm
11. Glossary of Terms and Symbols

This Appendix was taken from:

Fundamental Salvage Calculations, U.S. Naval School "Diving and Salvage," compiled by Lt. W. R. Bergman USN - revised by Lt. E. V. Downey USN, 1965.

IX. Stability.

Chapter 88 of BUSHIPS Technical Manual is the finest text available on stability. The intent of this guide would be aborted if we made an excessive review of all phases but the following will definitely assist in stability salvage computations.

A. Computing for GM.

Transverse Value

Sample Problem # 15

$$\text{Formula: } GM = \left(\frac{0.44 \times b^2}{T_i} \right)$$

Note: .44 is constant for all ships

b = beam

T_i = time in seconds for one complete roll (Port to STB'd and Back)

Given: Roll time = 10 sec

Beam = 35 feet

$$GM = \left(\frac{0.44 \times 35^2}{10} \right)^2$$

$$GM = \left(\frac{15.4}{10} \right)^2$$

$$GM = (1.54)^2$$

$$GM = 2.37 \text{ FT.}$$

As a fast review recall the successive points G (center of gravity) B (center of buoyancy) M (metacenter). The distance GM is a measure of initial stability and is called metacentric height. Now for illustration let us put a small list on the ship (refer to Plate # 2) you will note the quantity GZ which is the righting arm or the tendency of the ship to right itself, it will vary from 0 to a maximum value until an upsetting arm is experienced. Multiplying the righting arm by displacement gives us righting moment.

B. Computing BM (metacentric radius).

Sample Problem #16

$$\text{Formula: } BM = \frac{I}{V}$$

$$\text{Note: } I = \frac{Lb^3}{12}$$

V = Volume of under water body

Given: Box shaped lighter

$$L = 75$$

$$b = 28$$

$$H_m = 6'$$

Work:

$$I = \frac{75 \times 28^3}{12} = \frac{75 \times 22000}{12} = 137,500$$

$$V = 6 \times 75 \times 28 = 12,600$$

$$BM = \frac{137,500}{12,600} = 10.9$$

C. Shifting weight in the vertical plane from a low position to a higher position or vice versa.

It can be seen that moving a weight in the vertical plane will change the center of gravity. Look at plate # 3. The shift of gravity/GGI can be found as follows.

Formula: $GGI = \frac{w \times d}{W}$

Sample Problem # 17

Formula: $GGI = \frac{w \times d}{W}$

Note: w = weight moved
d = distance weight moved
W = displacement

Given: w = 10T
d = 20'
W = 1000 tons

Work:

$$GGI = \frac{10 \times 20}{1000}$$

$$GGI = \frac{200}{1000}$$

$$GGI = .2 \text{ Ft.}$$

The important thing to notice is the loss of righting arm GR which decreases GZ for the entire range of stability. The loss or gain of righting arm can be expressed as follows.

Formula $GR = GGI \times \text{sine angle } \chi$ (loss would take place raising, gain lowering)

d. Shifting weight in the atwartships direction.

The same formula $GGI = \frac{w \times d}{W}$ is used but the loss of righting arm is expressed as:

Plate # 3

Vertical movement of weight

$$GG^1 = \frac{w \times d}{W}$$

$$GR = GG^1 \times \sin \alpha$$

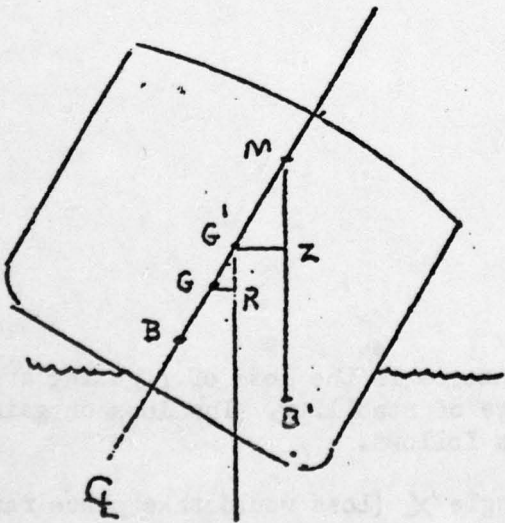
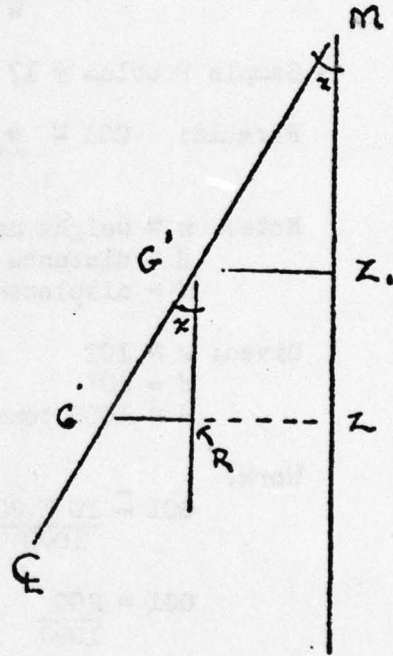
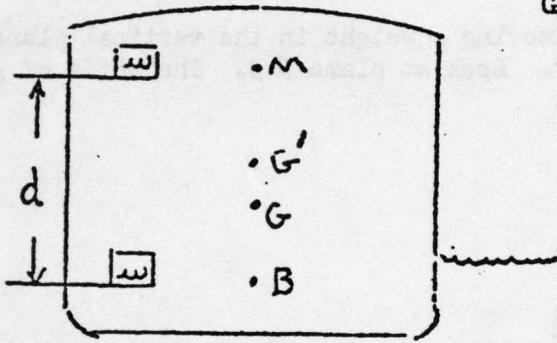
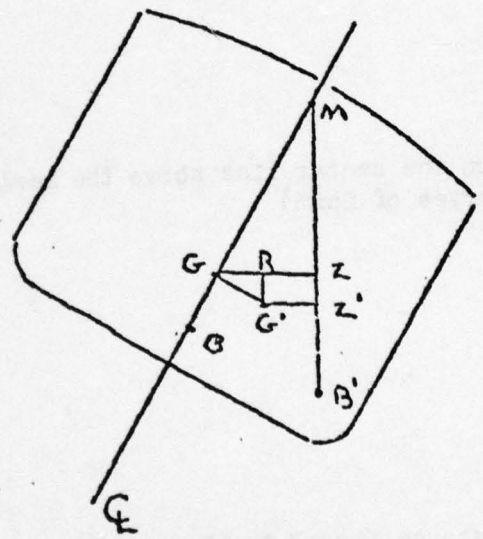
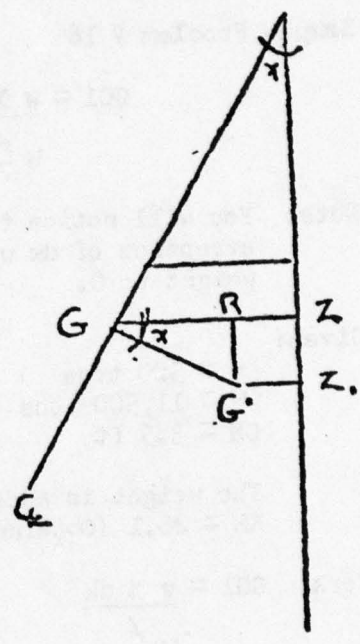
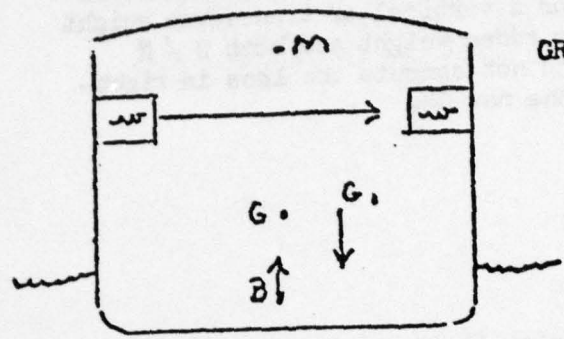

Plate # 4

horizontal movement of weight

$$GG_1 = \frac{w \times d}{W}$$

$$GR = GG_1 \times \cos \chi$$



FORMULAS

moment to heel $1^\circ = \frac{\Delta \times GM}{57.3}$ displacement

Formula: $GG_1 = W \times \cos \text{ angle}$ this is quickly understood by looking at Plate # 4.

E. Adding or subtracting new weight.

The easiest way of figuring this problem is by first assuming that you placed the weight at the center of gravity the G would remain the same. Then proceed as we would for a vertical or transverse weight movement. However you can see we have added weight and both B & M will change. Lets take one problem and not compute the loss in righting arm as we did before but compute the new GM.

Sample Problem # 18

$$GG_1 = \frac{w \times dk}{W - w}$$

Note: You will notice the similarity to the other formula with the exception of dk which is the vertical distance from the added weight to G.

Given:

$$\begin{aligned} w &= 500 \text{ tons} \\ W &= 11,500 \text{ tons} \\ GM &= 3.5 \text{ ft} \end{aligned}$$

The weight is added 41 ft on the center line above the keel.
KM = 28.1 (Obtained from curves of form)

Work: $GG_1 = \frac{w \times dk}{W - w}$

$$\frac{w}{W - w}$$

$$GG_1 = \frac{500 \times 16.4}{11,500 - 500} = .68 \text{ ft}$$

Discussion:

Where did 16.4 come from. Distance from K to where weight was placed was 41' KM (28.1) - GM (3.5) = KG (24.6) now G to weight = 41 - 24.6 = 16.4

$$KG_1 = KG (24.6) - GG_1 (.68) = 25.28 \approx 25.3$$

$$G_1M_1 = KM_1 - KG_1$$

$$2.5 = 27.8 - 25.3$$

F. Computing angle of list.

The time will come when we desire to compute the angle of list by adding a weight of the center line.

Sample Problem # 19

Formula:

$$\text{Tan of the angle} = \frac{w \times d}{(W - w)(G_1M_1)} \quad \text{New GM}$$

Discussion: When you find the tangent of the angle proceed to the tangent tables and extract the angle.

G. Loose water free surface effect.

Thus far we have talked about only solid weights. What about loose water or free surface effect by partial flooding of a compartment. Visualize an off center compartment half filled with water, as the ship heels this water moves, the weight shifts and causes a shift in the center of gravity. This will definitely cause a loss in our righting arm. For simplicity we will experience a "virtual rise" in the center of gravity by that we mean this shifting of water will effect the righting arm the same as if G had actually moved upward we could produce the same effect at some given point. It would be laborous and complicated to compute each and every loss for many different angles of heel. Therefore we have used the "virtual rise" method. To easily compute.

Sample Problem # 20

$$GGv = \frac{I}{V} = \frac{I}{\Delta \times 35}$$

Formula: $GGv = \frac{I}{V}$

Note: GGv = our virtual rise of gravity.

I = is our now familiar moment of inertia, in this case the moment of inertia of the free surface area about its own fore and aft axis.

$I = \frac{b^3 l}{12}$ b is the atwartship breath of the free surface with the ship upward.

Procedure: After computing the above the loss of righting arm may be found by this formula
 $GGv \times \text{sine of the angle of list on heel.}$

Note: The breath of the compartment is the key factor hence a single fore and aft centerline bulkhead which cuts a compartment in two will quarter the free surface effect.

H. Free surface effect with open communication to the sea. The case will arise when a compartment will be flooded and holed to the sea with water rushing in and out alternately. To establish the "virtual rise" in gravity and the corresponding effect on stability the following formula is used.

Sample Problem # 21

Formula $GGv = \frac{ay^2}{V}$

a = area of free surface in square ft.

y = atwartship distance from the center of the free surface to the ships centerline.

I. Moving weights in longitudinal plane. Thus far we have only discussed weight additions in the transverse plane lets now discuss weight movement in the longitudinal.

Sample Problem # 22

Formula: Change of trim = $\frac{\text{Trimming moment}}{\text{MTI}}$

Given: $H_a = 19' 9''$
 $H_f = 20' 3''$
 $H_m = 20'$

Move 50 tons of ammunition 300' aft.

MTI = 1,940 foot tons

Work: Moment = $50 \times 300 = 15,000$

Change of trim = $\frac{15,000}{1,940} = 8$ inches

Note: Since we are moving the weight aft the trim will be by the stern.

J. Computing change of Hm. This computation comes in very handy in applying parrallel rise or sinkage computations. In adding and substracting weights in particular flooding and deflooding compartments.

Formula: Change in Hm = $\frac{w}{\text{TPI}}$

w = Equals weight added or substracted

GLOSSARY OF TERMS AND SYMBOLS

a	- area of free surface in square feet
A	- area
AGW	- after grounding displacement
AP	- after perpendicular
b	- beam
B	- center of buoyancy
BGW	- before grounding displacement
BM	- transverse metacentric height
BML	- longitudinal metacentric height
Cb	- block coefficient
Cm	- midship coefficient
Cp	- waterplane coefficient
d	- distance
dk	- vertical distance from G to final height of weight
dn	- neutral point distance
dr	- physical distance from center of flotation to midpoint of actual grounding point
dw	- distance from center of flotation to where weight was moved.
F	- force
FP	- forward perpendicular
G	- center of gravity
G1	- new center of gravity
GGv	- virtual rise in center of gravity
GM	- metacentric height
GML	- longitudinal metacentric height
H	- head of water
Ha	- after draft
Hf	- forward draft.
Hm	- mean draft
HmAG	- mean draft after grounding
HmBG	- mean draft before grounding
I	- moment of inertia
K	- keel
KG	- distance from keel to center of gravity
KG1	- new distance from keel to center of gravity
KM	- distance from keel to metacenter
KM1	- new distance from keel to metacenter
L	- length
l _σ	- length of stiffeners in feet
l _{BP}	- length between perpendiculars
LOA	- length overall
M	- metacenter
M1	- new metacenter
M1I	- moment to trim one inch
NP	- neutral point
R	- ground reaction
RY	- tide reaction
T	- tons
Ti	- time for period of complete roll
TPI	- tons per inch immersion
U	- coefficients of friction
V	- volume
W	- displacement - Δ
w	- weight
y	- atwartship distance from center of free surface to the centerline
z	- section of modulus

APPENDIX D

Grounding Calculations

The basic calculations for determining the ground reaction of a stranded vessel and the factors that affect ground reaction are included in this Appendix. Sample problems are provided as examples of the calculation procedure. The following areas are treated.

1. Ground reaction and methods for determining:
 - a) Change of mean draft method
 - b) Tons per inch immersion (TPI) method
 - c) Computing ground reaction using forward draft readings.
2. Computations of TPI and MTI
3. Determination of the neutral loading point
4. Tide effects on ground reaction
5. Glossary of terms and symbols

Also included in this Appendix is a table of average vessel dimensions.

The grounding calculations were taken from:

Fundamental Salvage Calculations, U.S. Naval School (Diving and Salvage," compiled by Lt. W. R. Bergman USN - revised by Lt. E. V. Downey USN, 1965.

The table of average vessel dimensions is based on a table taken from:

Emergency Transfer Systems for Disabled Tankers, Supervisor of Salvage, Naval Ship Systems Command, prepared by Murphy Pacific Marine Salvage Co., contract N00024-73-C-0273 (Task 74-11), p. 32.

III. Ground reaction and methods for determining.

Consider a ship moving with a certain speed over a body of water whose sea bottom is gradually shoaling. If the ship maintains its course and speed toward the shoal at some point in its travel the keel of the ship will touch the bottom from this point of contact the kinetic energy of the ship will begin to expend itself in two ways. First, is in the conversion into frictional energy in stopping the ship. Second, is in the conversion into potential energy in raising the ship. This raising of the ship or changing its mean draft (H_m) to a lower value is the effect of producing ground reaction (R). Ground reaction may be defined as how many tons aground the vessel is. In proceeding we will assume the center of floatation is exactly amidships.

A. Change of mean draft method:

This is the easiest method of computing ground reaction. Both the forward and after draft readings must be available to utilize this method. Occasionally such conditions as heavy surf, ground swells, and extreme counter design at times render this method useless.

Sample Problem # 2

Formula: $R = BGW - AGW$

Assumed: Curves of form available

Procedure: Take H_f and H_a and compute H_m before grounding. Use curves of form to obtain displacement. Take H_f and H_a and compute H_m after grounding. Use curves of form and derive after ground displacement.

Given: $BGW = 2100 \text{ T}$
 $AGW = 1850 \text{ T}$
 $R = 2100 \text{ T} - 1850 \text{ T}$
 $R = 250 \text{ T}$

B. TPI Method:

The same results may be approximated by finding the product of the change of mean draft (H_m) in inches and the value of TPI. This is a handy method in situations where the curves of form are not available, nor is initial displacement but you do possess a rough estimate of TPI.

Sample Problem # 3

Formula: $R = (HmBG - HmAG)TPI$

Given: $HmBG = 10'6''$

$HmAG = 9'3''$

$TPI = 20.2T$

Work: $R = (10'6'' - 9'3'') 20.2T$

$R = (15'') 20.2T$

$R = 303T$

to determine how much pull required, multiply tons by coefficients. (Pg. 3)

C. Computing ground reaction using forward draft readings:

Two methods of computing values of R have been discussed; in each of these methods an after draft reading after grounding is required. In the majority of stranding situations the obtaining of an after draft reading is virtually impossible due to the presence of ground swells, heavy seas breaking over the stern, extreme list etc. These situations will naturally necessitate the estimation of R by a method utilizing information from the curves of form or values of MTI and TPI obtained on scene which will be discussed later.

Sample Problem # 4

Formula: $R = 2 \cdot \frac{MTI \cdot TPI \cdot \text{change in Hf in inches}}{(2MTI) \cdot (dr \cdot TPI)}$

Given: $HFBG = 10'$

$HFAB = 8'$

$BGW = 1680$

$MTI = 365'T$

$TPI = 20T$

$dr = 100'$ (This new term dr is the location, in feet, of the point of ground contact to the midship perpendicular)

Work: $R = \frac{2 \times 365 \times 20 \times 24}{(2 \times 365) \cdot (100 \times 20)}$

$R = \frac{350,400}{2,730}$

$R = 128T$

IV. Computations of TPI and MTI

The novice will see the importance of the values of TPI and MTI in salvage computations. They are mandatory math tools of the salvor. Curves of form are the frosting on the cake and many times they are not available so lets proceed with this hypothesis that they are not available. First look over the tabulated chart below. These coefficients in brevity are a relation of the actual volume by shape of the vessel as compared to the block square volumes utilizing beam, height, and length measurements.

For comparison the following figures are given:

TYPE	BLOCK C_b COEFFICIENT	MIDSHIP C_m COEFFICIENT	WATERPLANE C_p COEFFICIENT
Ocean Liner	.597	.956	.725
Large Cargo	.775	.992	.848
Larger Tanker	.757	.978	.845
Great Lakes Freighter	.874	.990	.918
Yacht	.565	.938	.724
Harbor Tug	.585	.892	.800
Destroyer	.521	.833	.740
Cruiser	.573	.820	.714
Lifeboat	.600		

A. Finding TPI with physical measurements of the ship and the standard table of ship block, midship, and waterplane coefficients.

Sample Problem # 5

Formula:

$$TPI = \frac{b \times L \times C_p}{420}$$

Procedure: First find at the waterline of the stranded ship the length and the beam and multiply them together giving you the area of the waterplane. However this is the block area and our vessel has a taper at bow and stern. Refer to the standard table of ship coefficients and select under the C_p column for the vessel you are working with.

Given: Destroyer type

$$b = 30'$$

$$L = 300'$$

$$TPI = \frac{b \times L \times C_p}{420}$$

$$TPI = \frac{30 \times 300 \times .740}{420}$$

$$TPI = \frac{9000 \times .740}{420}$$

$$TPI = \frac{6660.0}{420}$$

$$TPI = 15.85 \text{ Tons}$$

B. Computing TPI with TPI of a similar ship known. This TPI of a similar ship could be obtained from numerous sources. Either before getting underway to the salvage scene or on arrival. We also will need to know the length and beam of both the similar ship and the ship stranded/grounded.

Sample Problem # 6

$$\text{Formula: } TPI(1) = TPI(2) \frac{L_1}{L_2} \cdot \frac{b_2}{b_1}$$

(Note use of 1 and 2 are not math functions but a labeling of two ships 1 being the stranded ship and 2 designating similar ship.)

Given: $TPI(2) = 12$
 $L_1 = 200$
 $L_2 = 210$
 $b_1 = 39$
 $b_2 = 39$

Works: $TPI(1) = 12 \left(\frac{200}{210} \cdot \frac{39}{39} \right)$
 $TPI(1) = 12 \left(\frac{20}{21} \cdot 1 \right)$

$$TPI(1) = 12(.95 \times 1)$$

$$TPI(1) = 12 (.95)$$

$$TPI(1) = 11.45(T)$$

Computations of MTI. We have pretty well covered TPI lets move on to MTI. Computations with no curves of form available.

C. MTI solution with TPI known.

Sample Problem # 7

$$\text{Formula: } \frac{MTI}{b} = 30 \times TPI^2$$

Given: $TPI = 12$
 $b = 35$

Note: The figure 30 is a constant for all ships

$$\text{Work: } MTI = \frac{30 \times (12)^2}{35}$$

$$MTI = \frac{30 \times 144}{35}$$

$$MTI = \frac{4320}{35}$$

$$MTI = 123 \text{ T}$$

D. MTI solution with GM1 known

Sample Problem # 8

$$\text{Formula: } MTI = \frac{GM1 \times W}{12L}$$

Note: 12 is constant for all ships

$$\text{Given: } W = 2000$$

$$GM1 = 80$$

$$L = 200$$

$$\text{Works: } MTI = \frac{80 \times 2000}{12 \times 200}$$

$$MTI = \frac{160,000}{24,000}$$

$$MTI = 66.7 \text{ T}$$

Comment: If longitudinal metecentric radius (BM1) is known it is readily seen that it could be substituted for GM1 since they are approximately equal.

E. Calculating MTI with known MTI of a similar ship and the length and beam of both ships known. Again this is a simple proportion problem as we discussed in the TPI section.

Sample Problem # 9

$$\text{Formula: } MTI1 = MTI2 \left(\frac{L1}{L2} \right)^2 \times \frac{b1}{b2}$$

$$\begin{aligned} \text{Given: } MTI2 &= 80 \\ L1 &= 200 \\ L2 &= 205 \\ b1 &= 40 \\ B2 &= 40 \end{aligned}$$

$$\text{Work: } MTI1 = 80 \left(\frac{200}{205} \right)^2 \times \left(\frac{40}{40} \right)$$

$$MTI1 = 80 (.9506) \times 1$$

$$MTI = 76.2$$

F. Computing MTI with only L and b of the stranded ship known

Sample Problem # 10

Formula: $MTI = \frac{L^2 b}{5040}$

Given: $L = 200$
 $b = 30$

Note: 5040 constant for all ships

Work: $MTI = \frac{(200)^2 \times 30}{5040}$

$$MTI = \frac{40000 \times 30}{5040}$$

$$MTI = \frac{12,000,000}{5040}$$

$$MTI = 238 T$$

V. Determination of the neutral loading point.

A ship may be aground in one of two ways. It may be aground along its entire length or it may be only partially aground. Depending upon circumstances, trimming may be possible, therefore some point exists along the length of the ship where weight may be added or removed without changing the magnitude of ground reaction. We said before that the center was to be considered as being located at the midships perpendicular for our discussions, I'm confident that you realize while the vessel is afloat this point, in reality, is actually located either forward or aft of the midship perpendicular. This is the point then that all longitudinal movements of the vessel evolve about. As the result of the grounding this

longitudinal pivot point must shift to a new location as a direct effect of the segment of force R, tending to raise the ship. This new pivot point is called the neutral loading point (NP) and is the point where weight may be added or removed without affecting the ground reaction.

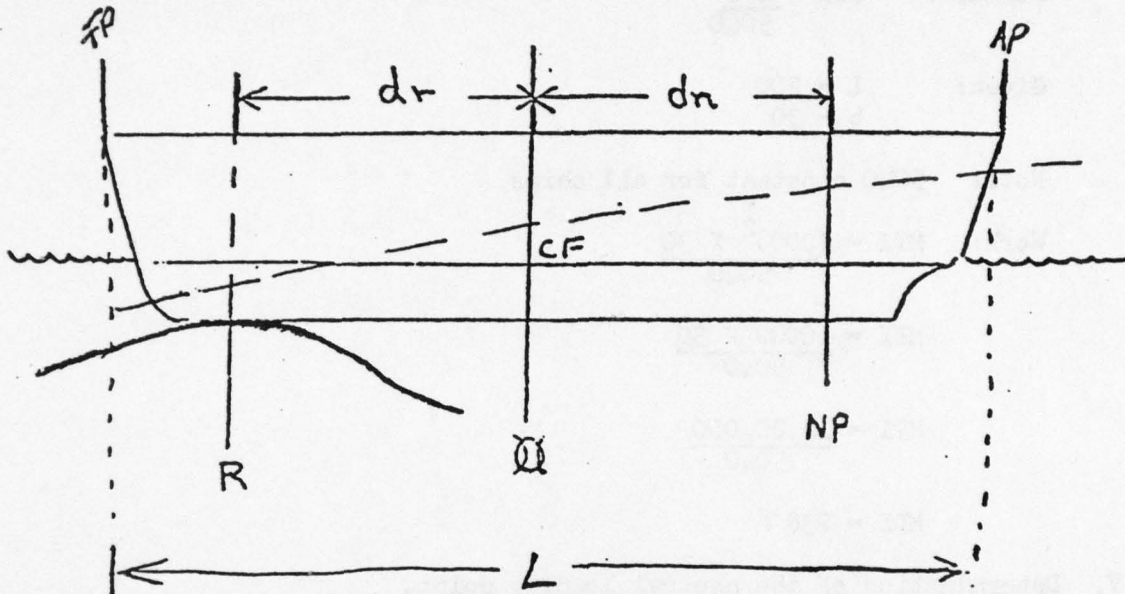

In looking over the above sketch we can see that if weight is added at R, R increases by the amount equal to the weight. As the weight is shifted aft and closer to the neutral point the less effect the weight has on R. If the shift continues past NP going aft it will result in a decrease of R.

Sample Problem # 11

$$\text{Formula: } dn = \frac{MTI \cdot L}{TPI \cdot dr}$$

Given: MTI = 180 T
 TPI = 15T
 dr = 30'
 L = 200'

$$\text{Work: } dn = \frac{180 \times 200}{15 \times 30}$$

$$dn = \frac{36,000}{450}$$

$$dn = 80'$$

VI. Tide effects on ground reaction.

In most instances when a vessel is stranded she is in a position where the tide may cause her to change trim as she rests on the rocks. It is therefore mandatory to determine what is the effect of tide on the ground reaction. To determine the change of R due to rise of tide it must be re-

membered that the change of tide occuring at the actual location counts and they must be calculated from the tide tables to this point. In over theoretical simplication, to relate trim to the center of flotation, assume that the ship is free floating and that the rock rises, pushing the ship at the point of grounding out of the water an amount equal to the rise in tide.

Sample Problem #12

Formula: $RY = \frac{Y \cdot TPI \cdot MTI \cdot L}{(MTI \cdot L + (TPI \cdot dr^2))}$

Note: Always figure Y in inches

Given: Y = 24"
MTI = 200'T
TPI = 15T
L = 200'
dr = 30'

$$RY = \frac{24 \cdot 15 \cdot 200 \cdot 200}{(200 \cdot 200) + (15 \cdot 900)}$$

$$RY = \frac{14,400,000}{53,500}$$

$$RY = 269T$$

GLOSSARY OF TERMS AND SYMBOLS

a	- area of free surface in square feet
A	- area
AGW	- after grounding displacement
AP	- after perpendicular
b	- beam
B	- center of buoyancy
BGW	- before grounding displacement
BM	- transverse metacentric height
BM _L	- longitudinal metacentric height
C _b	- block coefficient
C _m	- midship coefficient
C _p	- waterplane coefficient
d	- distance
dk	- vertical distance from G to final height of weight
dn	- neutral point distance
dr	- physical distance from center of flotation to midpoint of actual grounding point
dw	- distance from center of flotation to where weight was moved.
F	- force
FP	- forward perpendicular
G	- center of gravity
G ₁	- new center of gravity
GG _v	- virtual rise in center of gravity
GM	- metacentric height
GM _L	- longitudinal metacentric height
H	- head of water
H _a	- after draft
H _f	- forward draft.
H _m	- mean draft
H _{mAG}	- mean draft after grounding
H _{mBG}	- mean draft before grounding
I	- moment of inertia
K	- keel
KG	- distance from keel to center of gravity
KG ₁	- new distance from keel to center of gravity
KM	- distance from keel to metacenter
K ₁ M ₁	- new distance from keel to metacenter
L	- length
L ₀	- length of stiffeners in feet
LBP	- length between perpendiculars
LOA	- length overall
M	- metacenter
M ₁	- new metacenter
MTI	- moment to trim one inch
NP	- neutral point
R	- ground reaction
RY	- tide reaction
T	- tons
T _i	- time for period of complete roll
TPI	- tons per inch immersion
U	- coefficients of friction
V	- volume
W	- displacement - Δ
w	- weight
y	- atwartship distance from center of free surface to the centerline
z	- section of modulus

APPROXIMATE TANKER DIMENSIONS

Dead Weight Tonnage (DWT)	L.O.A. (ft)	Beam (ft)	Draft (ft)	Tons Per Inch Immersion (TPI)
15,000	480	70	27	70
25,000	590	80	33	90
50,000	730	100	40	140
100,000	880	125	50	220
200,000	1,070	155	62	350

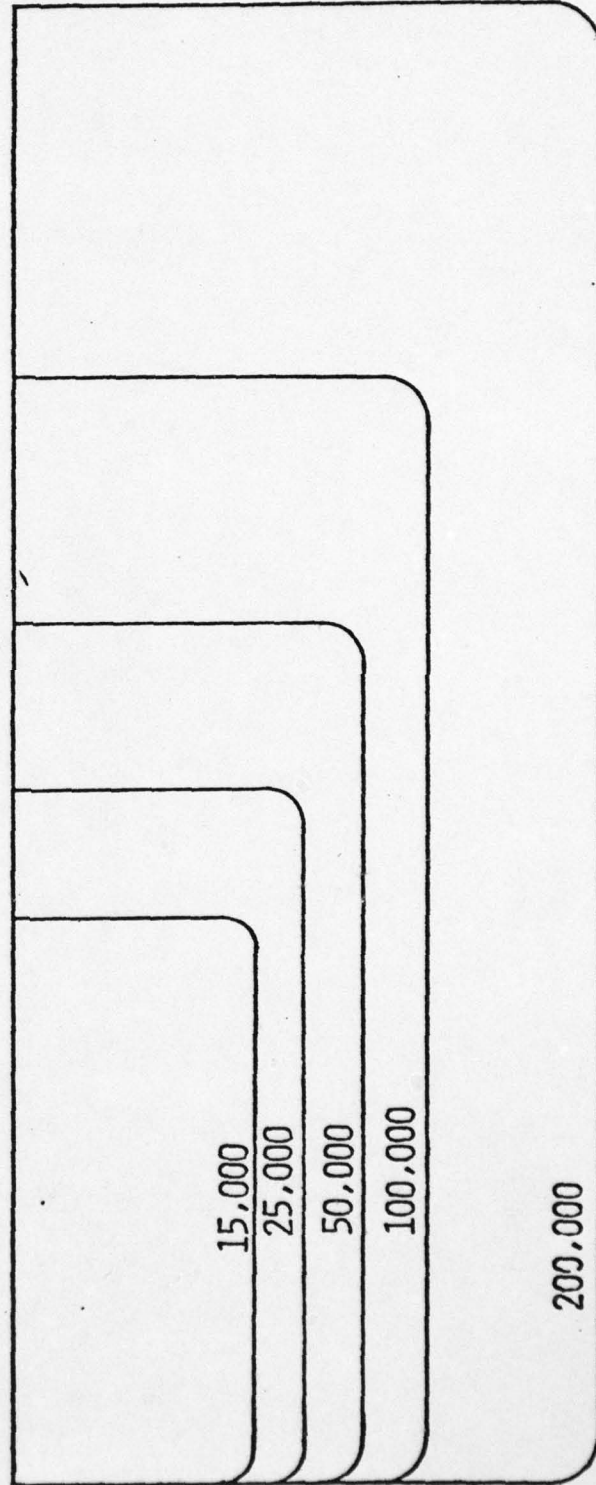

APPENDIX E

Pump Performance Characteristics

Several graphs of ADAPTS pumping capacity⁽¹⁾ for different pressure heads, discharge hose lengths, and oil types are included in this Appendix. A graph of seawater pumping capacity⁽¹⁾ for ADAPTS is also given. A graph of oil viscosity as a function of temperature⁽¹⁾ for several oil types, a graph of pump performance degradation⁽²⁾ as a function of viscosity, and a graph of thermal decay of oil cargos⁽³⁾ for various tanker classes will be helpful in evaluation the reduction in pumping capacity which occurs when cargo heaters fail. A final table of common salvage pump capacities⁽⁴⁾ in tons of seawater per minute is provided to aid in evaluating ballasting times.

References

1. Operating Instructions for ADAPTS Type II Pumping Sub System, vol. I, U.S. Coast Guard, Ocean Engineering Div., March 1963, pp. (2-42)-(2-45), 2-49.
2. Mittleman, J., Cold Oil Pumping Studies, Naval Coastal Systems Center, NCSC TM209-78, May 1978, p. 19.
3. Emergency Transfer Systems for Disabled Tankers, Supervisor of Salvage, Naval Ship Systems Command, prepared by Murphy Pacific Marine Salvage Co., contract N00024-73-C-0273 (Task 74-11), p. 20.
4. Ship Salvage Notes, U.S. Naval School, "Diving and Salvage," Feb. 1968, p. 287.

FIGURE E-1
 SUBMERSIBLE PUMP AND TRANSFER HOSE
 PERFORMANCE CHARACTERISTICS
 (AT PUMP RATED SPEED - 1750 RPM)
 NAVY SPECIAL
 (95 S.S.U. @ 130 °F)

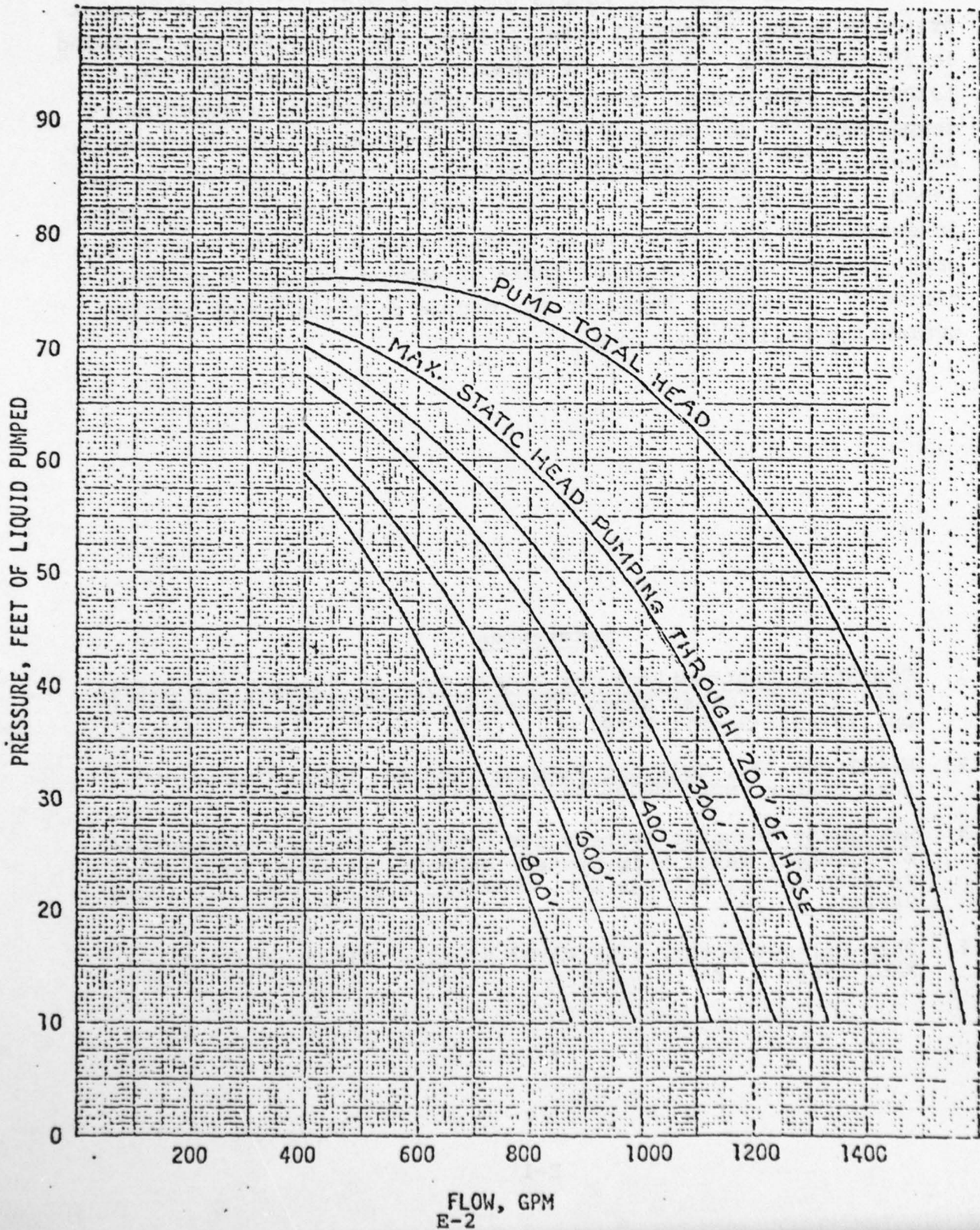

FIGURE E. 2
 SUBMERSIBLE PUMP AND TRANSFER HOSE
 PERFORMANCE CHARACTERISTICS
 (AT PUMP RATED SPEED - 1750 RPM)
 CRUDE OIL
 (340 S.S.U. @ 130 °F)

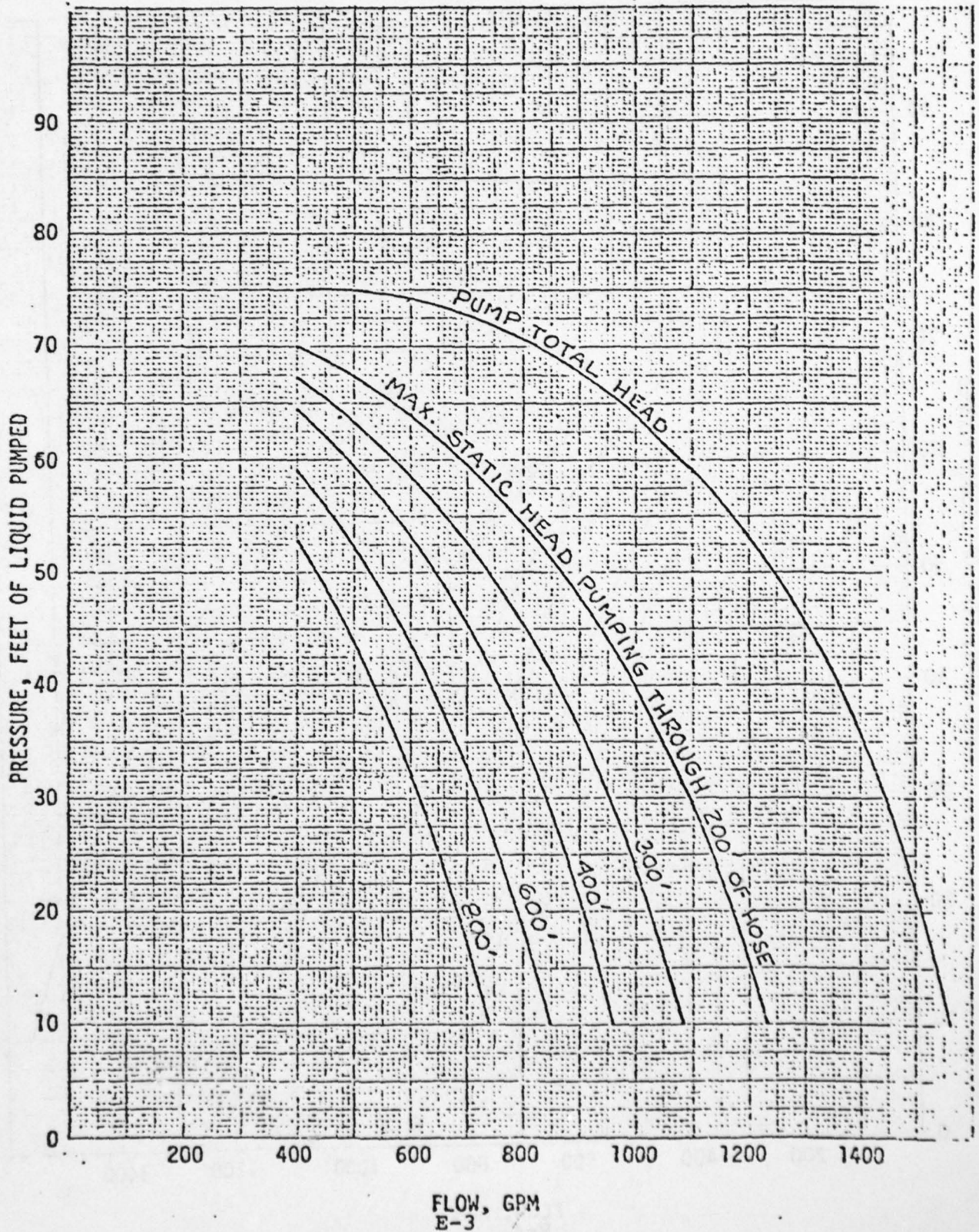
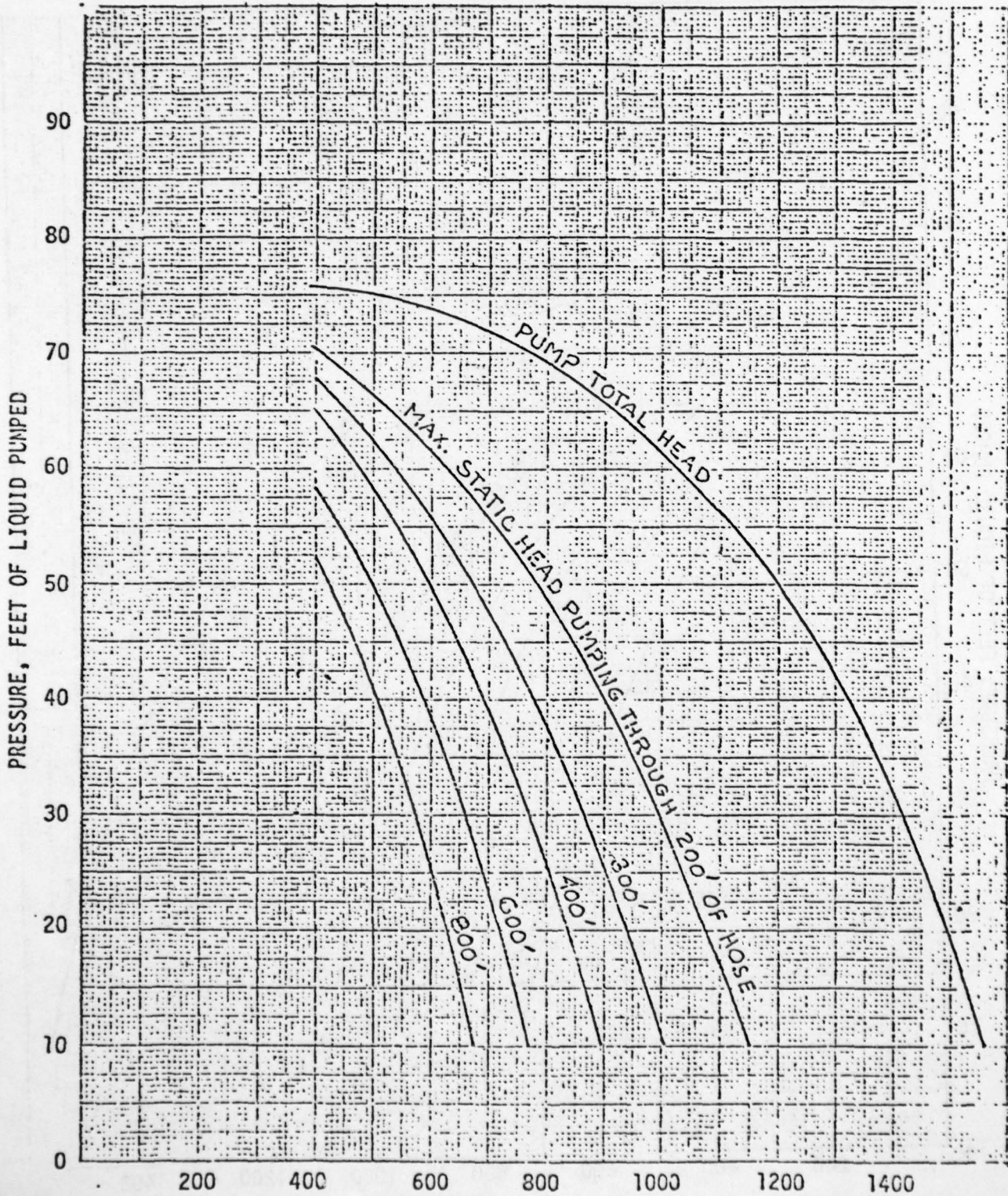
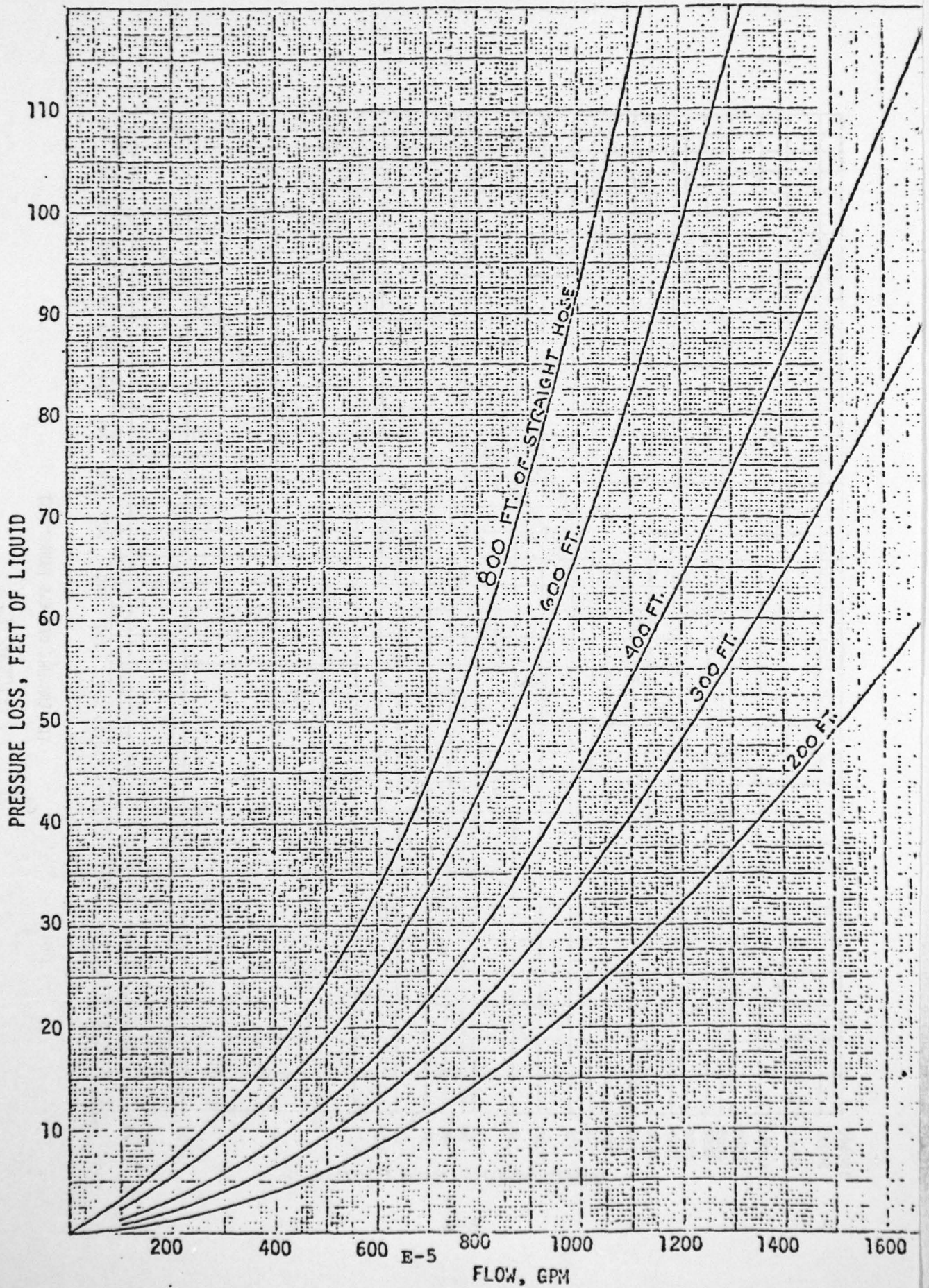
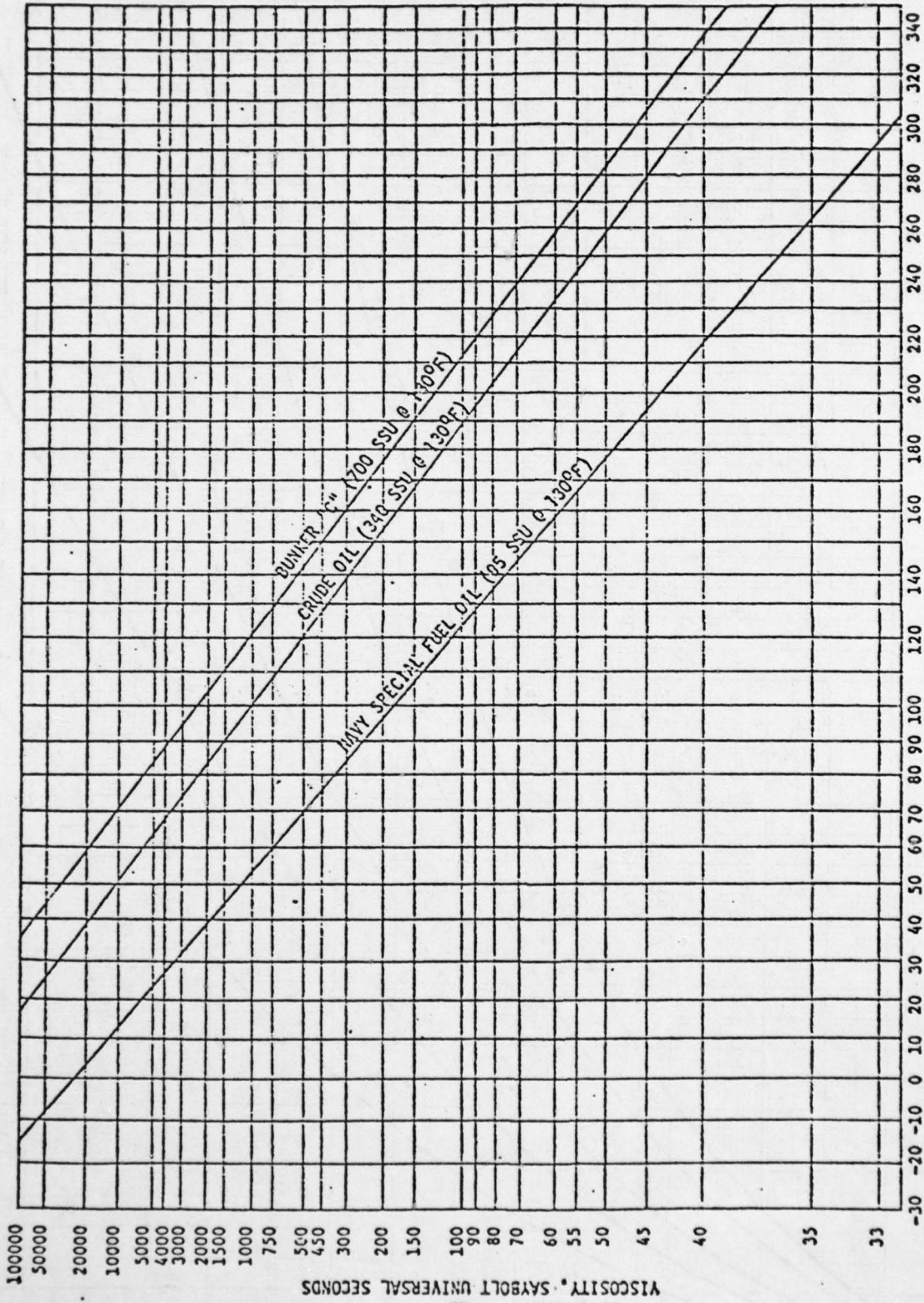

FIGURE E-3
 SUBMERSIBLE PUMP AND TRANSFER HOSE
 PERFORMANCE CHARACTERISTICS
 (AT PUMP RATED SPEED - 1750 RPM)
 BUNKER "C"
 (700 S.S.U. @ 130 °F)



SEAWATER





TEMPERATURE DEGREES FAHRENHEIT

FIGURE E.5
OIL VISCOSITIES

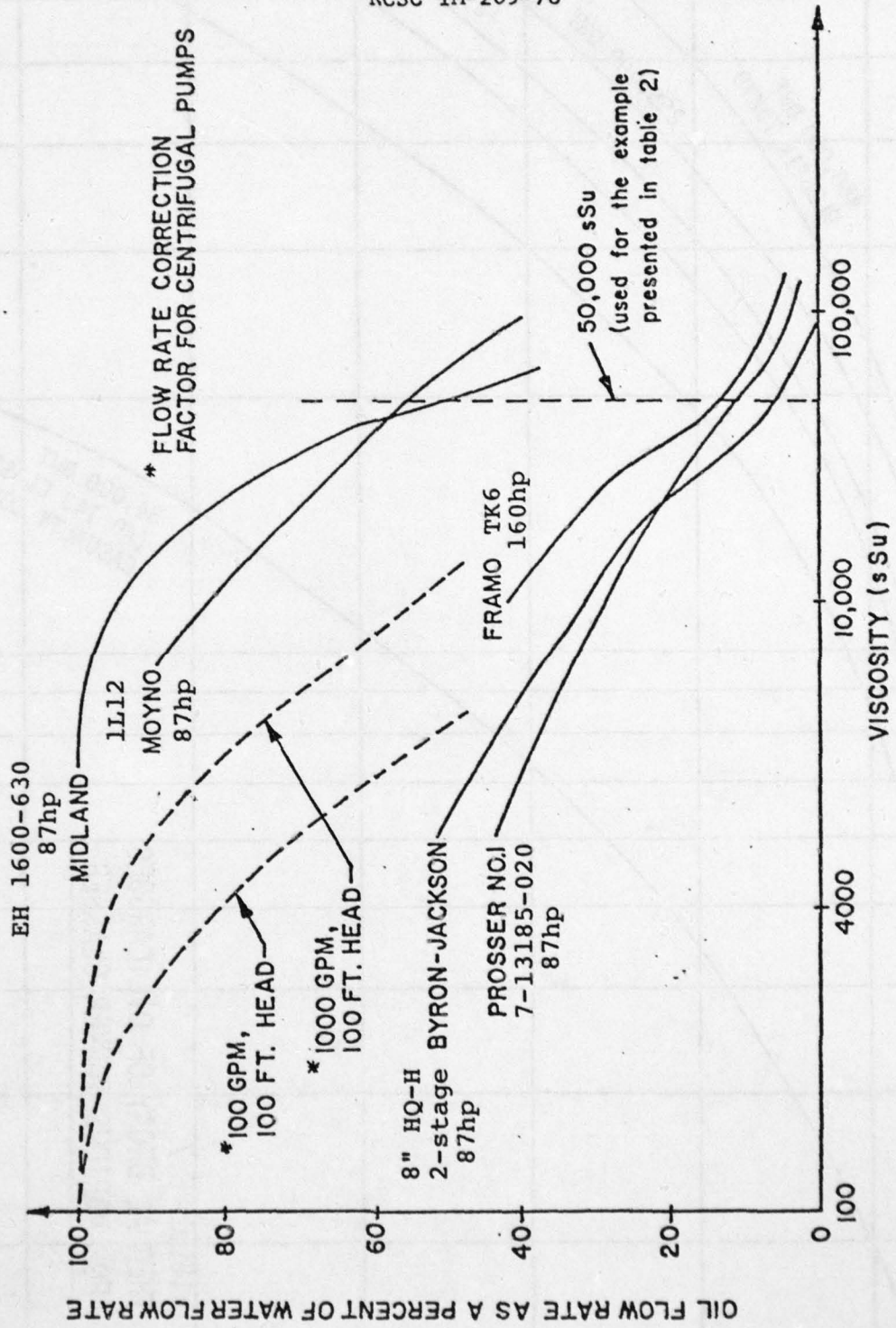

FIGURE E.6 PERFORMANCE DEGRADATION 2

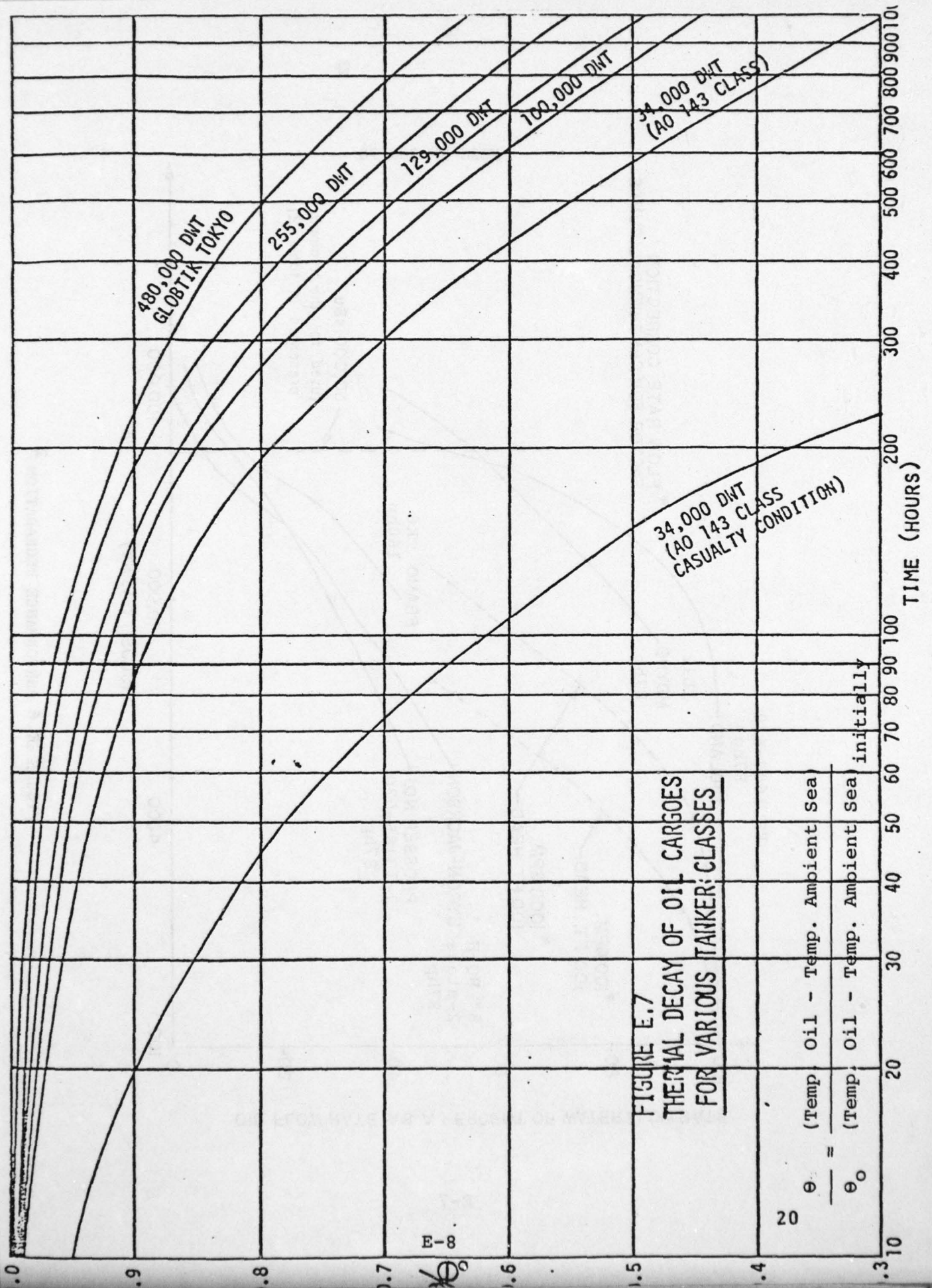

FIGURE E.7
 THERMAL DECAY OF OIL CARGOES
 FOR VARIOUS TANKER CLASSES

FIGURE E.8
SALVAGE PUMP CAPACITIES

Tons per minute

One ton 2240 lbs.
 One gal 8.53 lbs.
 One C.F. 64 lbs. (sea)

<u>TOTAL HEAD</u>	<u>SUCTION HEAD</u>			
	<u>10 Feet</u>	<u>15 Feet</u>	<u>20 Feet</u>	<u>25 Feet</u>
<u>10" Pump</u>				
15 Feet	12.2			
20 "	11.9	10.9		
25 "	11.7	10.8	9.9	
30 "	11.3	10.7	9.8	6.8
40 "	10.7	10.2	9.3	6.5
50 "	9.6	9.45	8.7	6.0
60 "	8.00	8.00	7.7	5.3
70 "	5.25	5.25	5.25	4.6
<u>6 " Pump</u>				
25 Feet	5.7			
30 "	5.6	4.9	4.0	3.01
40 "	5.5	4.7	3.9	2.97
50 "	5.1	4.4	3.7	2.80
60 "	4.7	4.0	3.4	2.63
70 "	4.0	3.4	2.9	2.32
<u>3 " Pump</u>				
25 Feet	1.23	1.09	0.90	
30 "	1.21	1.04	0.88	0.64
40 "	1.12	1.01	0.83	0.63
50 "	1.00	0.86	0.74	0.60
60 "	0.91	0.72	0.72	0.56

AD-A079 714

SEAWARD INTERNATIONAL INC FALLS CHURCH VA
OIL POLLUTION RESPONSE PLANNING GUIDE FOR EXTREME WEATHER. (U)
NOV 79

F/G 6/6

DOT-CG-80372-A

UNCLASSIFIED

USCG-D-3-80

NL

3 OF 3

AD
A079714



END
DATE
FILMED
3-80
DDC



MICROCOPY RESOLUTION TEST CHART
 NATIONAL BUREAU OF STANDARDS-1963-A

APPENDIX F

Wind and Current Force Calculations

The basic calculations for determining the wind and current forces acting on a vessel are included in this Appendix.

This Appendix was taken from:

Ogg, R. D., Anchors and Anchoring, 8th edition, 1977,
(Danforth), pp. 12-15.

the object in the windstream. Although the first correlation of these factors was published by Sir Isaac Newton as early as 1686, it is only because of aviation research that it is now possible to accurately predict air drag for various objects. The formula for air drag "D" is commonly expressed:

$$D = C_d \frac{\rho}{2} V^2 S$$

- ρ is the density of air, which varies as explained in a later paragraph.
- V is the wind velocity.
- S is the cross sectional area taken at right angles to the direction of the wind.
- C_d is the dimensionless coefficient of drag which varies with shape or profile and can be determined from wind tunnel tests.

Generally it is impractical to build a suitably scaled model and run tests on an individual boat. Therefore, we are including some typical values of C_d for estimating purposes. Variations in size of object and wind velocity affect these figures somewhat, but for practical purposes, the following values are suitable for estimation. You will note from these figures the tremendous importance of streamlining.

WIND DRAG

Wind force or "drag," as it is referred to in aerodynamics, is determined by wind velocity, air density, and shape of

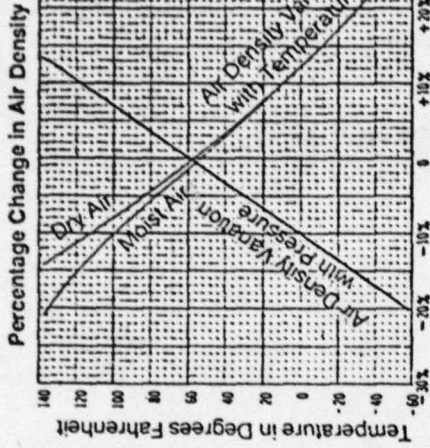
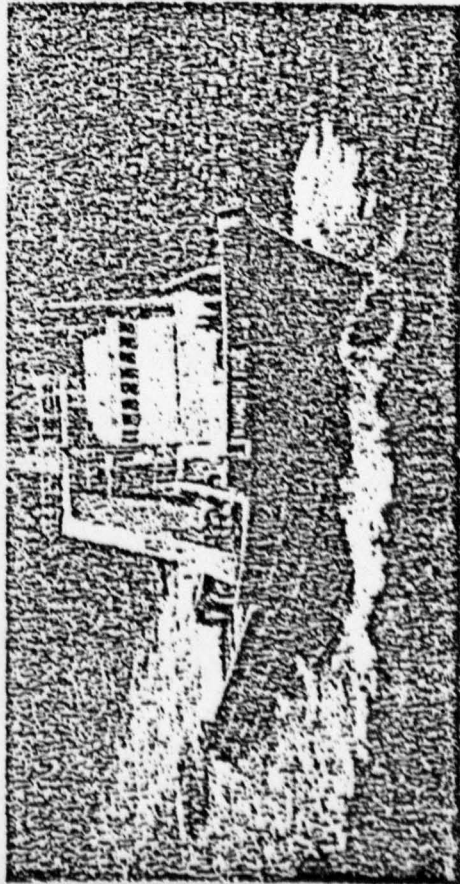

- Hollow hemisphere, concave to wind (like anemometer cup) 1.70
 - Fiat rectangular plate 1.28
 - Fiat circular disc 1.16
 - Wires, cylinders, masts, 1.00
 - Cargo liner, wind dead ahead95
 - Oil tanker, wind dead ahead85
 - Streamlined passenger liner, wind dead ahead,70
 - Pleasure boats, wind dead ahead, 70-1.00
 - Sphere47
 - Hollow hemisphere, convex to wind (like anemometer cup)38
 - Airplane09
 - Aircraft strut06
 - Streamlined cigar shape03
- Generally for pleasure boats a figure of .80 will be found satisfactory. A boat with a really sleek superstructure will run as low as .70 while a blocky pilot house might raise the figure to 1.00.

As may be noted from the previous formula, wind drag varies directly with the square of the wind velocity, with the cross sectional area, and with air density. Normal variations in air density will not materially affect estimated loads. However it is of interest to note the effects on air density and hence on wind drag that result from changes in barometer, temperature, and humidity (see chart). As might be expected, high barometric pressures will increase air density while high temperatures will lower it.

Humidity, contrary to usual assumption, decreases air density as may be realized when one considers that the density of water vapor (molecular weight 18.02) is only about five-eighths that of dry air (molecular weight 28.95). It is evident from the above that air with a given velocity on a cold dry day will exert more force than with the same velocity on a warm humid day, which accounts for some of the additional severity of winter seas. Also, a given wind velocity will drive a sailboat harder when there is a high barometer or during cold weather.

Substituting the density of U.S. standard atmosphere* in the above formula and converting to useful units where D_1 is in pounds, V_1 in knots and S_1 in square feet we get:

$$D_1 = .00339 C_d V_1^2 S_1$$

For convenience, several values of C_d are plotted in the chart showing drag in pounds per square foot of cross section versus wind velocity in knots. In using this formula it is well to note that surface winds, due to friction and turbulence caused by waves, usually have less velocity than unobstructed winds higher up. The value for S_1 can be figured from

* ($\rho = .0023779$ slugs / ft.³ at 59° F. with a barometer of 29.92 in. Hg NACA-NBS Standard)

boat plans or actual measurements and must include such items as masts, rigging, ventilators, etc.

As an example the wind drag of a streamlined boat with drag coefficient (Cd) of .70 having a cross sectional area (rigging included) of 80 square feet in a wind velocity of 60 knots would be calculated as follows:

$$D = .70 \times .00339 \times 60^2 \times 80$$

$$= 683 \text{ pounds}$$

As an alternate method, wind drag may easily be found by using the chart below. Here we find the drag per square foot is approximately 8.5 pounds. Hence:

$$D = 8.5 \times 80$$

$$= 680 \text{ pounds}$$

CURRENT DRAG

On rivers, in tidal areas, and during severe weather, current load can be appreciable, sometimes even greater than that due to the wind. During hurricanes and other similar storms abnormal currents should be anticipated.

Current drag is generally easier to understand than wind drag because of its

To use graph below, estimate profile drag coefficient as described in text. With assumed wind speed, wind drag in pounds per square foot and hence total wind drag for any object may be determined. As an added refinement, allowance may be made for barometric pressure, temperature, and humidity from graph on preceding page.

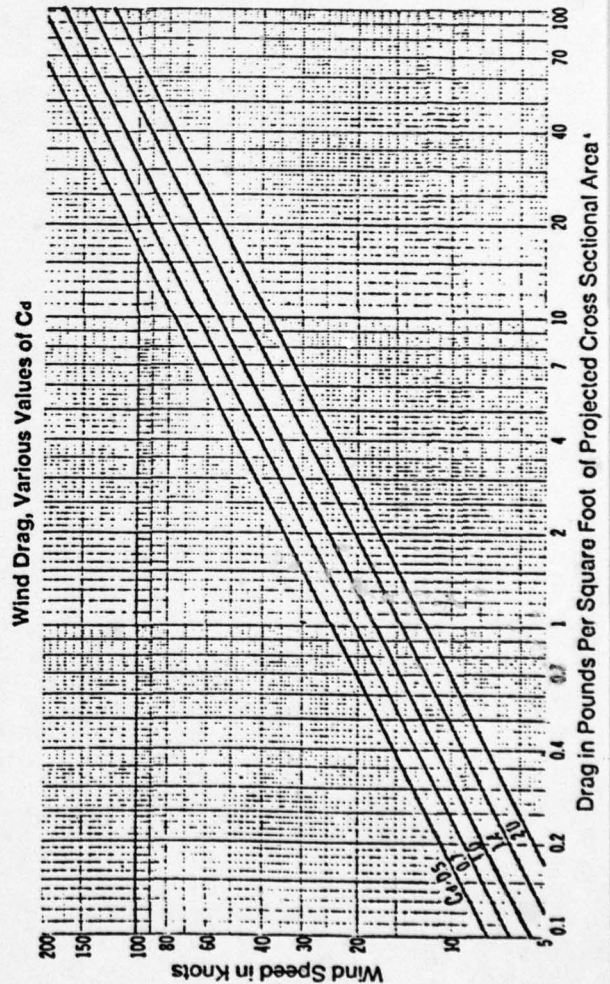

relationship to boat propulsion. It requires approximately the same force to propel or tow a boat through the water at a given speed as it would take to hold a boat against a current of the same velocity. Considerable data in this respect is available through such sources as boat, engine, and propeller manufacturers, naval architects, etc.

While current drag can be measured directly by towing a boat, it may be approximated as follows from propulsive data:

$$R_i = \frac{325.5(P \times \text{RPM} - 1216 \times V)H}{V \times P \times \text{RPM}}$$

Where: R_i is the current drag in pounds

P is the propeller pitch in inches

RPM is the propeller revolutions per minute.

V is the velocity in knots

H is the engine horsepower delivered at the desired

speed, and may be estimated from engine performance data when the

engine RPM and intake manifold vacuum or throttle opening are known.

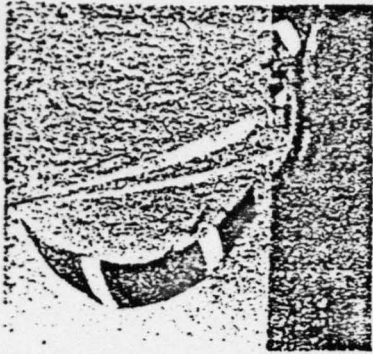

As an example to determine the resistance of a forty foot cruising sloop in a five knot current, a test run was made using a 60 horsepower auxiliary engine. A velocity of five knots was achieved at 1000 propeller RPM with the engine delivering an estimated twenty horsepower to an eight inch pitch propeller. Substituting in the above formula we get:

$$R = \frac{325.5(6 \times 1000 - 1216 \times 5)20}{5 \times 8 \times 1000}$$

$$= 312.5 \text{ pounds.}$$

If you really want to include everything, you may also consider your propeller drag. To visualize propeller drag in pounds, double the square footage in the propeller and multiply by the current velocity in knots squared. This rule is for propellers in a hull aperture; for entirely exposed propellers add fifty per cent to this figure.

APPENDIX G

Tug Power Requirements for Towing

"In estimating the power required for the towing ship (ships) it will be sufficiently accurate to take the towing resistance of the dock*, i.e., the tow rope pull, as 1 lb. per sq. ft. of wetted surface at a speed of 4½ knots. This varies only slightly according to the molded lines of the dock's*under-water body. The resistance at other speeds, up to a certain limit, will vary almost directly as the square of the speed. Most tugs may be figured as giving a tow rope pull of about one ton for every 100 ihp."

In heavy seas, 3 times this estimated pull may be required.

Taken from:

The U.S. Navy Towing Manual

*This paragraph refers to the towing resistance of a floating drydock. It will serve as a rough estimate for towing other vessels.

APPENDIX H

Key Response Item Data Sheets

Presented here are commercial data sheets on many of the key response items discussed in this report. These are systems that appear to be viable and are currently or soon-to-be available in the American marketplace.

EMERGENCY CARGO PUMPS

Framo Offloading System

TECHNICAL SPECIFICATIONS

TK5 pump, suitable for most chemicals and light to medium viscosity products.

Applications: Emergency discharge, transfer and fire fighting.
 Materials exposed to cargo: Stainless steel AISI 316 L and Teflon.
 Capacity: 190 m³/h. against 70 mwc. ref. diagram.
 Hydraulic motor: Axial piston design.
 Hydraulic working pressure: 320 bar.
 Hydraulic oil flow: 130 l/min.

FRAMO patented cofferdam/shaft seal arrangement eliminates contamination risk. The pump is supplied with 18 m. of concentrically fitted pressure and return hydraulic hoses, with control valve and snap-on couplings.

TK6 pump, suitable for SW. and petroleum products of light to heavy viscosity.

Applications: Emergency discharge, transfer and dewatering.
 Material in housing: Coated SW-resisting aluminium.
 Material in impeller: Stainless steel AISI 316.
 Capacity: 500 m³/h. against 30 mwc.
 Hydraulic motor: Axial piston design.
 Hydraulic working pressure: 240 bar.
 Hydraulic oil flow: 210 l/min.

The pump is fitted with snap-on couplings for connection of separate pressure and return hydraulic hoses.

Dieselhydraulic, selfcontained powerpack, for operation of one TK5 or one TK6 pump at rated capacity.

Diesel engine rating: 160 HP at 2800 rpm.
 Hydraulic pump: Axial piston design.
 Hydraulic working pressure: Max. 320 bar.
 Hydraulic oil flow: Max. 210 l/min. (at 250 bar).
 Hydraulic oil expansion tank: Volume 80 l.
 Hydraulic cooling system: Part. flow, automatic engaged.
 Diesel fuel start tank: Volume 30 l.
 External fuel supply: Valved 1/2" snap-coupling.
 Engine start system: Hydraulic, automatic and manual recharging.
 Engine stop system: Hydraulic, automatic stop for engine and hydraulic system malfunction.
 Exhaust: Twin spark arresting silencer.
 Instrument and controls: Hydraulic, mechanical.

The powerpack is built as a compact portable unit with skid base and aluminium frame.

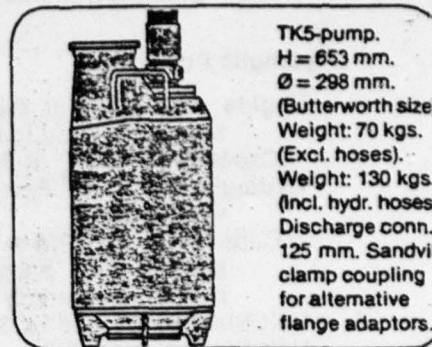

TK5-pump.
 H = 653 mm.
 Ø = 298 mm.
 (Butterworth size)
 Weight: 70 kgs.
 (Excl. hoses).
 Weight: 130 kgs.
 (Incl. hydr. hoses)
 Discharge conn.
 125 mm. Sandvii
 clamp coupling
 for alternative
 flange adaptors.

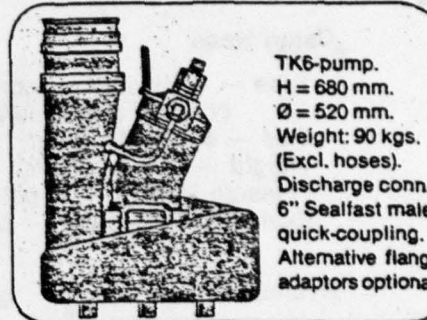

TK6-pump.
 H = 680 mm.
 Ø = 520 mm.
 Weight: 90 kgs.
 (Excl. hoses).
 Discharge conn.
 6" Sealfast male
 quick-coupling.
 Alternative flang
 adaptors optional

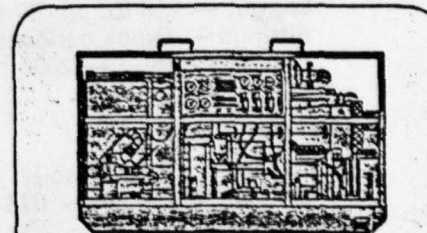

Dieselhydraulic Powerpack.

L = 2100 mm., B = 800 mm., H = 1200 mm.
 Weight incl. oil and fuel ready to start:
 1100 kgs.

PERFORMANCE

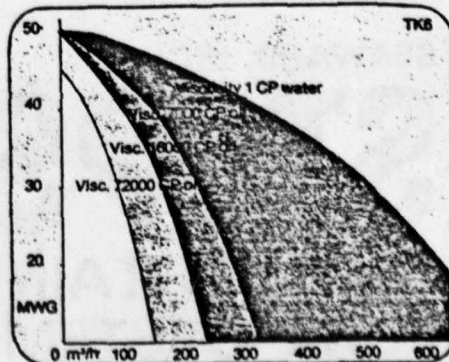
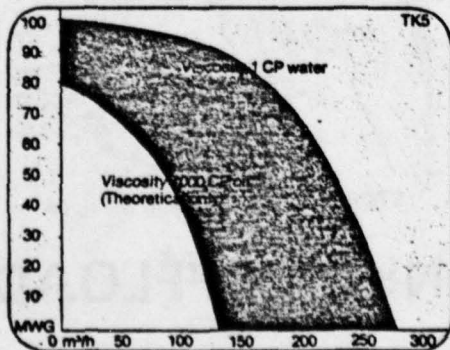

SPECIFICATIONS

Submersible Pump

Type — 8-inch, single stage, submersible turbine pump, hydraulically driven
Capacity — See Curve
Size — 10" OD x 60" long
Weight — 200 lb., including drive motor

Hydraulic Power Unit

Engine — 4 cylinder diesel, air cooled, manual/hydraulic start
Capacity — 40 HP at 3000 RPM
Hydraulic Pump — Fixed displacement, vane type
Capacity — 29 GPM at 3000 RPM, 2000 psi working pressure. 35 gallon hydraulic reservoir
Unit Size — 45" x 48" x 36"
Unit Weight — 1100 lb.

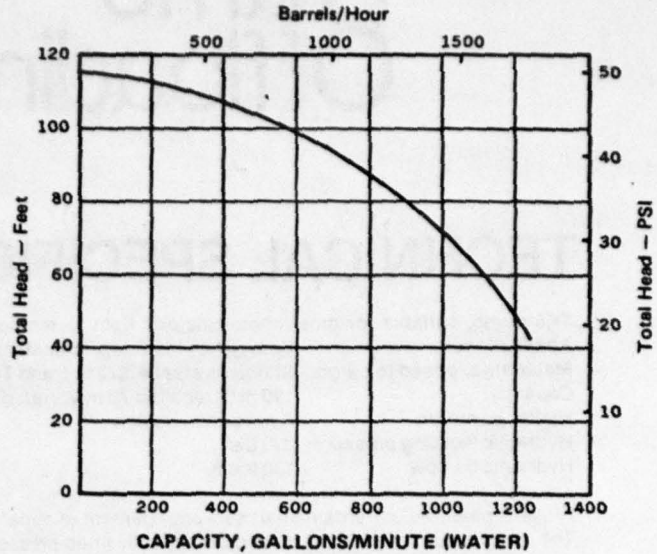

Cargo Hose

Type — Lightweight, fabric reinforced rubber collapsible discharge hose fitted with aluminum quick connect cam-type end fittings
Size — 6-inch diameter, 50 feet long
Weight — 115 lb. per 50' length, including end fittings
Pressure Rating — 75 psi working; 275 burst
Explosion Protection — Double wire electrical ground in hose wall

Hydraulic Hose

Size — 1-inch inside diameter, 80 ft. per section
Weight — 110 lb. per 80 ft. section
Fittings — Quick connect type
Pressure Rating — 2000 psi working; 8000 psi minimum burst

Handling Gear

Tripod — 2 ton capacity, legs adjustable from 8 ft. to 15 ft.
Manual Grip Hoist — 3/4 ton capacity with 5/16" wire rope
Combined Weight — 250 lb.

Optional Accessories

Hose Guide
External Fuel Bladder
Flow Meter
Pump Flange Adapter
Pump Booster Adapter

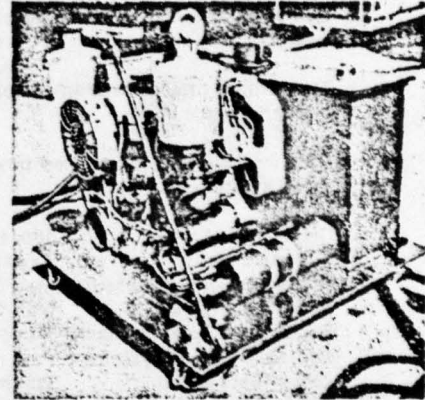

STOPS Hydraulic Power Unit

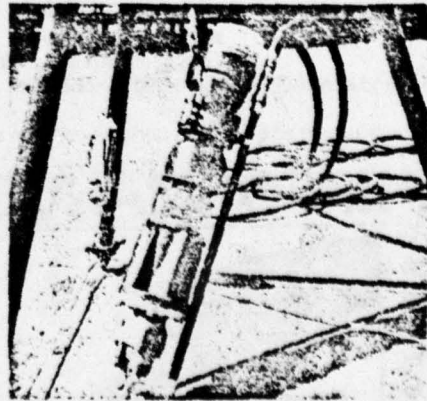

STOPS Submersible Pump & Tripod

SEAWARD, INC.

STOPS

SELF-CONTAINED TANKER OFFLOADING PUMP SYSTEM

Faint, illegible text in the top left column.

Faint, illegible text in the middle left column.

Faint, illegible text in the top middle column.

Faint, illegible text in the middle middle column.

Faint, illegible text in the top right column.

Faint, illegible text in the middle right column.

OIL SKIMMERS

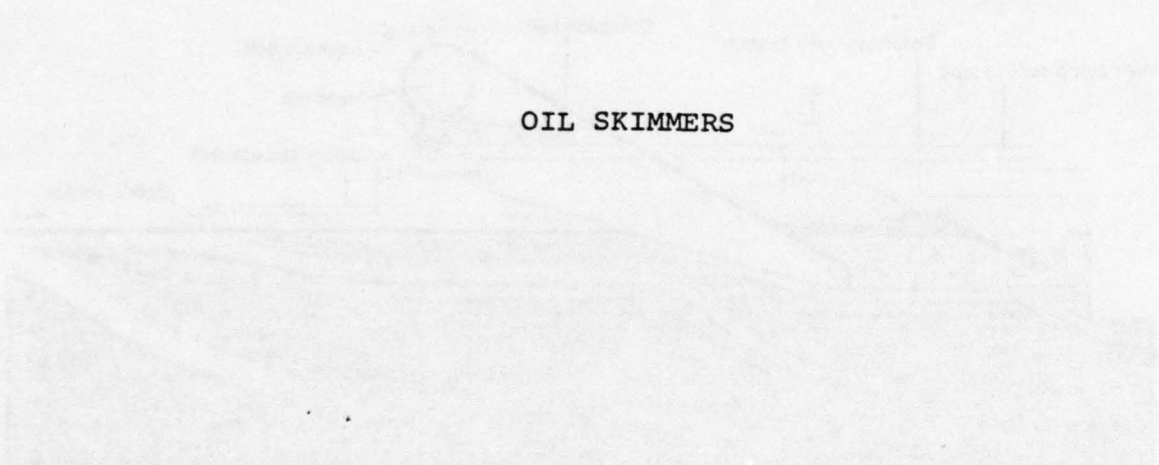

BENNETT SKIMMERS

Standard System

The bow ramp functions as a variable height weir, by-passing most of the incoming water underneath the skimmer and allowing only the surface layer of oil and water to pass into the interhull area. This, together with the operation of the gill doors, has the effect of reducing the interhull flow velocity relative to the skimmer's speed through the water. Debris is filtered out of the incoming oil and water by a sloped screen which facilitates its transfer to the debris storage rack. (A debris conveyor may be fitted instead of a screen.) Oil draining from the storage rack runs into the interhull collection area.

The oil layer flowing through the interhull area next comes into contact with the dry belt at almost zero rela-

tive velocity, since both are moving in the same direction. The belt displaces the oil layer beneath the surface of the water and the hydrostatic pressure forces the oil layer into close contact with the belt. This accelerates absorption of low viscosity oils and adsorption of high viscosity oils. (The dual absorptive and adsorptive properties of the belt eliminate the need to modify the system for changes in oil viscosity.)

Oil removal from the belt is carried out through the perforated squeeze belt running in contact with the main belt around the head roll. Squeezing over the large surface area of the head roll keeps the main belt in compression for an extended period, ensuring the thorough removal of all oil. High viscosity oils are removed

from the squeeze belt by a scraper.

For very heavy oil flows the secondary weir system comes into action, trapping any oil not collected by the belt. Oil accumulates underneath the variable height weir and then flows through ports into the sump.

Unitised System

The unitised system is designed for installation in existing catamaran hulls or where it is desired to raise all interhull skimming equipment out of the water for high speed transit. It differs from the standard system in that the leading edge of the scoop replaces the bow ramp and the flow control vane replaces the gill doors. In very heavy oil flows, oil may be pumped directly from the back of the scoop.

Fig. 5 STANDARD SYSTEM

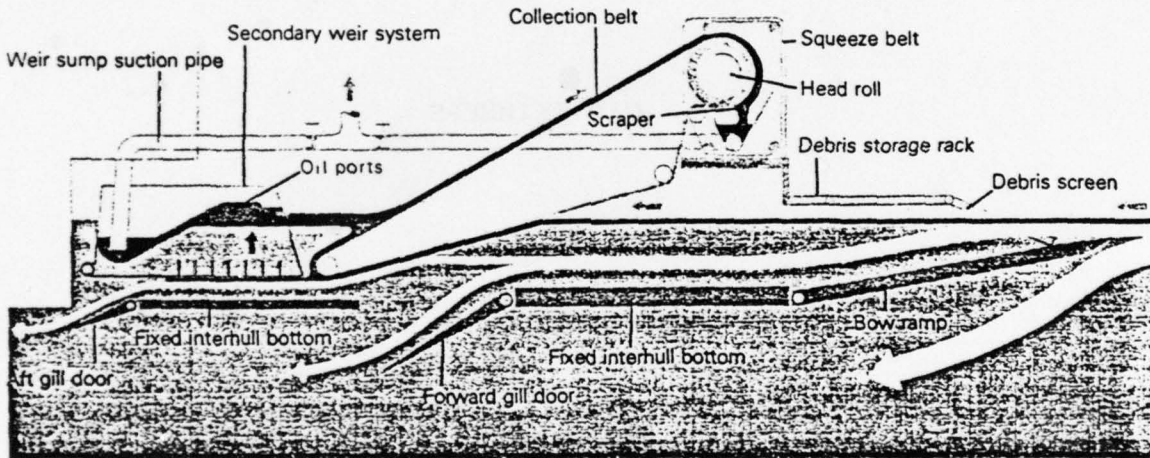

THROUGHPUT EFFICIENCY = the quantity of oil picked up by the skimmer expressed as a percentage of the oil presented to it. (Sometimes referred to as Oil Recovery Factor.)

COLLECTION EFFICIENCY = percentage of oil in the recovered oil/water mixture. (Sometimes referred to as Oil Content Factor.)

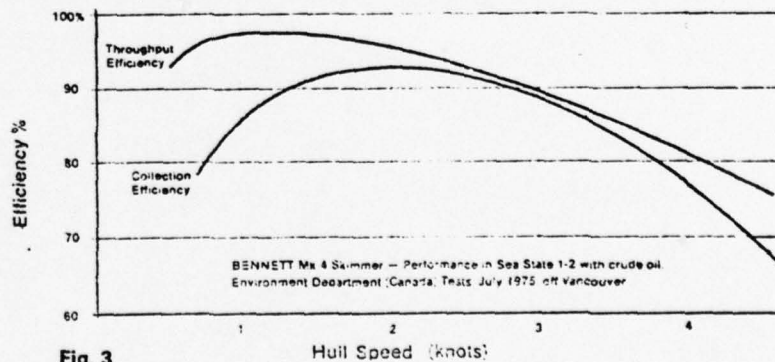

Fig. 3

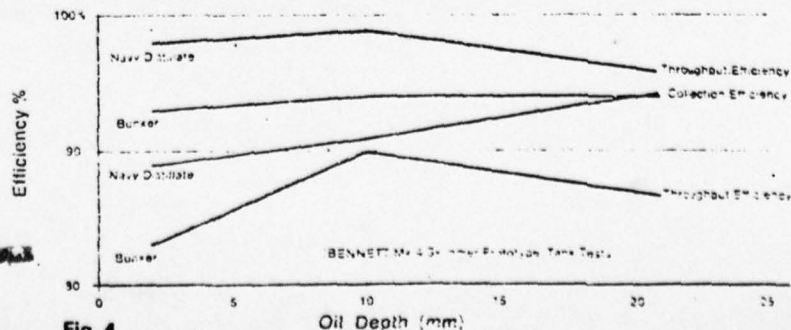
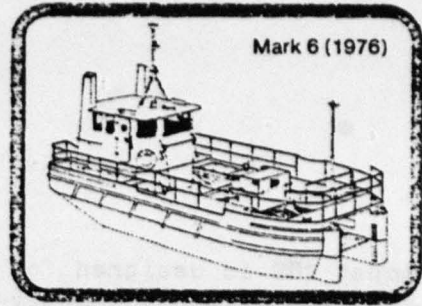
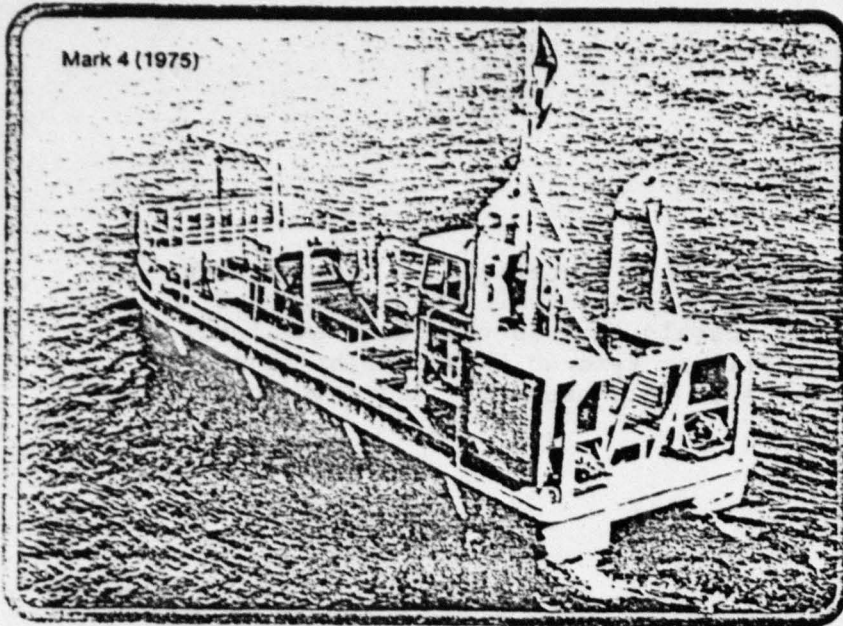

Fig. 4

BENNETT MARK 4 AND 6



Mark 6D

The Mark 6 range of skimmers has been developed from the successful Mark 4 unit. The Mark 6D features a central diesel/hydraulic power plant with twin oversterm hydraulic propulsion units. It is designed for inshore/offshore skimming duties up to sea state 3. Large deck area for auxiliary equipment storage. Crane with grapple for oversize debris handling.

Length: 42 ft (12.8 m)
 Beam: 14 ft (4.27 m)
 Speed: 5 - 10 knots
 Oil recovery rate:
 350 U.S. gpm (79.5 m³/hr)
 Oil storage:
 2500 U.S. gallons (9.46 m³)

The Bennett Mark IV Skimmer is a self-propelled unit powered by two GM 6V53 engines.

3.6.2 Specifications.

Length Overall	40'-03"	(12.3 metres)
Beam	11'-11"	(3.6 metres)
Draft - Loaded		
Ballast Pontoons on	7'-00"	(2.1 metres)
Ballast Pontoons off	3'-05"	(1.0 metres)
Freeboard	2'-00"	(0.6 metres)
Shipping Height	10'-06"	(3.2 metres)
Power - 2 G.M. 6V53 Diesel		
Engines rated at	240 H.P. (2200 RPM)	
Propulsion and Steering	2 Schottel 360° Drives	
Design Speed	7 Knots	
Pumpage	Moyno progressive capacity pumps	
Construction	Aluminum	
Gross Weight	34,000 lbs.	(15.4 metric tons)
(shipping configuration)		
Towing	Lugs provided fore and aft	

CYCLONET 100

Cyclonet 100 is designed for slick-skimming operations in the open sea. It consists of two one-meter-diameter Cyclonets which may be mounted on either side of moderately sized vessels such as trawlers, small oil tankers, etc. Maximum flow of oil mixture removed is 180 m³/hr (this is maximum discharge of pump provided). Ship speed may lie between 3 and 10 knots.

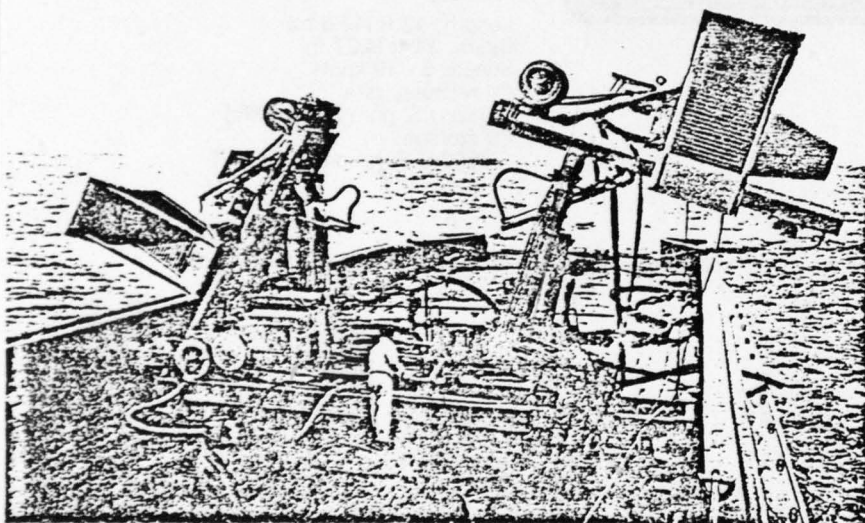

2. Lowering two Cyclonet 100s into position.

3. Dynamic Cyclonets—schematic

1. Screen 2. Inlet 3. Separation in cyclone
4. Clean water 5. Oil

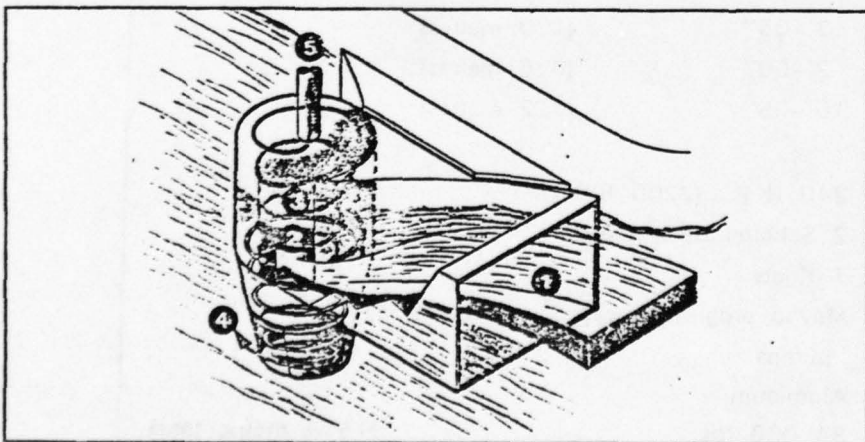

DYNAMIC CYCLONETS

Dynamic Cyclonets may be fitted to all conventional cranes and require no source of energy other than the speed of the crane.

Oil and water scoop from the surface into the Cyclonet by means of the oil separator and by centrifugal force within the chamber and gravity and flow through the top. Clean water flows out through a slot near the bottom. The intake and outlet are arranged to produce maximum centrifugal effect within the chamber. Unlike other devices where not in use.

FRAMO

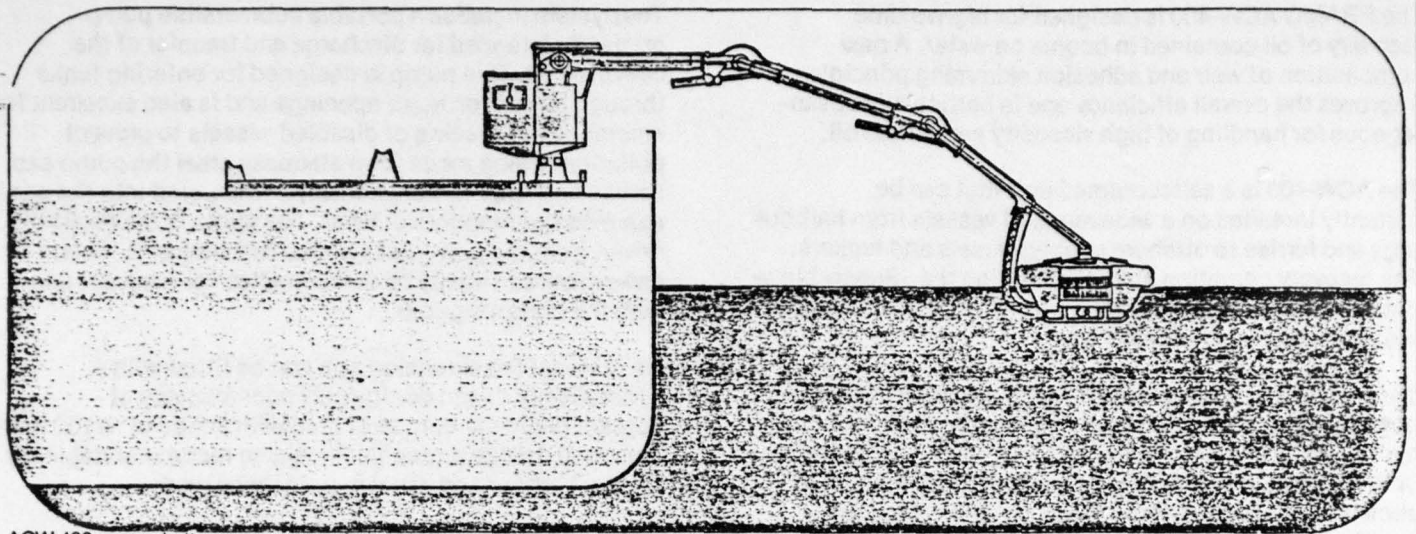

ACW-400, normal oil recovery operation.

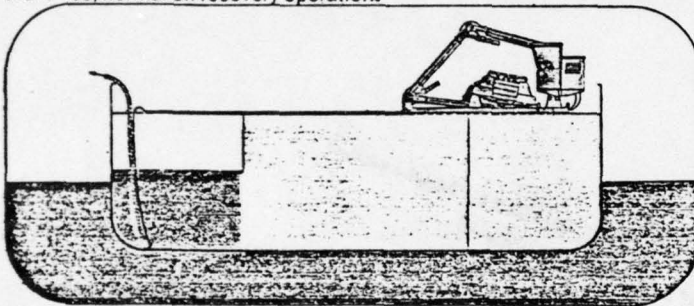

Recovery unit in parked position. Discharge of recovered oil by the portable submersible pump.

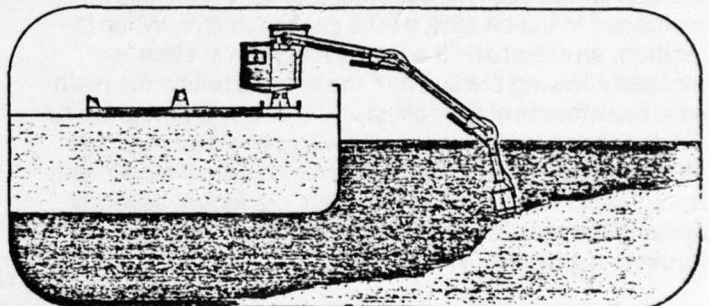

Dredge pump fitted on the extension arm for recovery of contaminated sand, reed etc., or dredging.

Performance

The ACW-400 is designed for operation under sea-state 4-5 Beaufort, with significant waves of 2-3 m. Based upon the results achieved during the operation at Ekofisk in May 1977, the system was approved by the Norwegian Authorities for the North Sea contingency maintained by the field operators clean seas group.

The ACW-400 will handle light diesel oil as well as emulsified, cold and viscous crude and bunker fuel. The recovery arrangement can be adjusted from a closed adhesion system for the light diesel film to an open flow high volume weir system which on heavy layers is limited by the transfer pump capacity only.

The great advantage is, however, achieved through the combination of the systems. In addition to the adhesion function the recovery drums have a conveyor effect and accumulate oil ahead of the adjustable weir barrier. This forces the water level down and create a heavy layer which gravitates over the weir with minimum water content. The surplus oil being accumulated under the guiding vanes will then also be flushed over the weir and eliminate clogging.

Operational conditions Capacity/head Watercontent beyond emulsion

Viscosity 100 C. Stoke Oil layer 20 cm. Oil layer 2,5 cm.	400 m ³ /h - 35 mwc. 60 m ³ /h - 45 mwc.	Max. 20% Max. 10%
Viscosity 500 C. Stoke Oil layer 20 cm. Oil layer 2,5 cm.	250 m ³ /h - 40 mwc. 100 m ³ /h - 45 mwc.	Max. 15% Max. 10%
Viscosity 1500 C. Stoke Oil layer 20 cm. Oil layer 2,5 cm.	150 m ³ /h - 35 mwc. 100 m ³ /h - 40 mwc.	Max 10% Max. 15%

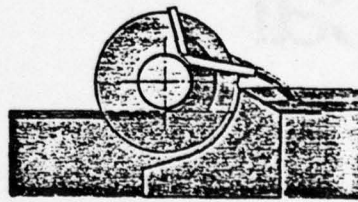

Pumpwell/weir in upper position. All oil being carried over adhesion discs. Maximum capacity abt. 100 m³/h

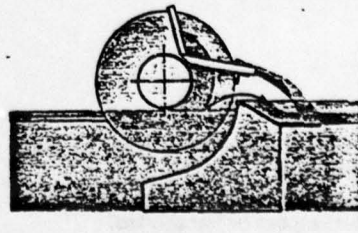

Pumpwell/weir in middle position. Accumulated oil gravitating over the barrier. Surplus oil under guiding vanes being flushed over the barrier.

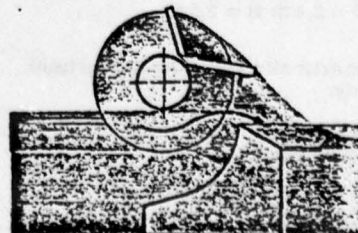

Pumpwell/weir in lower position. Surface oil layer gravitating directly into pumpwell. Conveyor effect of recovery drum improving the flow of oil over the barrier.

FRAMO (Contd.)

The FRAMO ACW-400 is designed for high volume recovery of oil contained in booms on water. A new combination of weir and adhesion skimming principles improves the overall efficiency and is particularly advantageous for handling of high viscosity emulsified oil.

The ACW-400 is a self-contained unit that can be instantly installed on a wide range of vessels from harbour tugs and ferries to offshore supply vessels and tankers. The recovery operation at Ekofisk during the «Bravo» blow-out proved successful operation from an offshore supply vessel in sea state 4-5 Beaufort.

The recovery system is controlled by one man from an operation cabin. The skimmer head is mounted on a hydraulically balanced extension arm which incorporates both oil transfer and hydraulic transmission lines, thus eliminating all hose handling problems. From parked position on the deck the skimmer's head is launched and positioned in the oil slick by the extension arm. When in position, an automatic load compensation system is engaged allowing the arm and the head to follow the main wave movements at an ideal stable skimming draught. The skimmer head can be moved sideways and the extension adjusted independent of the automatic vertical movement. The skimmer head can be lifted back on deck in seconds allowing the recovery vessel to retreat immediately if required in emergency.

The system includes a portable submersible pump primarily intended for discharge and transfer of the collected oil. This pump is designed for entering tanks through butterworthsize openings and is also excellent for emergency offloading of disabled vessels to prevent pollution. Being made from stainless steel the pump can handle both oils and chemicals, and lowered into the sea it can feed fire monitors at 9 bar. The pump is hydraulically driven from the powerpack on the recovery unit. This powerpack can easily be disconnected for separate use with the portable pump.

As optional the extension arm can be fitted with a hydraulically driven dredge pump for recovery of contaminated sand, mud or reed with solids of ϕ 100 mm. This mini dredge arrangement is also recommendable for regular harbour and canal maintenance work.

THIS PAGE IS BEST QUALITY FRAMOTECH
FROM COPY PUBLISHED TO DGS

Technical Data

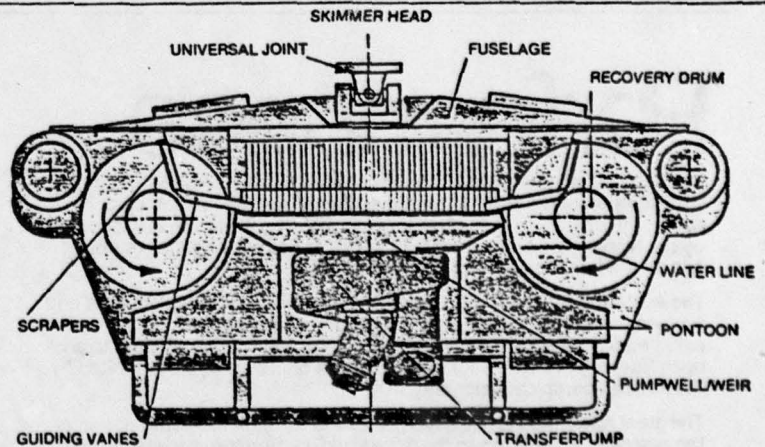

The recovery unit is assembled on a steel base. Prior to operation the base must be welded or bolted to the deck.

In parked position the arm and the skimmer head is secured on the base and the complete ready to start unit can be transported.

Overall dimensions: L = 6,8 m, H = 3,4 m B = 2,5 m
Total weight: 7.000 kgs

Operator cabin, powerpack and the extension arm with skimmer head are mounted on a swing loader body.

Prime mover: Diesel or electric 160 HP
Hydraulic system pressure: Max. 250 kp/cm²
Arm extension: Max 10,5 m
Max. base level above water line: 3 m
Initial lift impulse (load compensated arm): 60 kp
Loader body swing: 360°

The complete self-contained powerpack can be disconnected for emergency offloading operations etc. All hydraulic connections are fitted with valved snap-on couplings.

The skimmer head is constructed in SW-resisting aluminium. Four recovery drums with discs are assembled in a square configuration outside the adjustable weir/pumpwell. All functions are hydraulically operated and adjusted from the operator cabin.

Drum speed: 0-30 rpm.
Pump speed: 0-2000 rpm.
Weir level: Water line — 45 m. to + 80 mm.
Material: A57S.

H-10 The skimmer head is connected to the extension arm by a universal joint. All hydraulic connections are by valved snap-on couplings.

JBF DIP OIL RECOVERY SYSTEMS

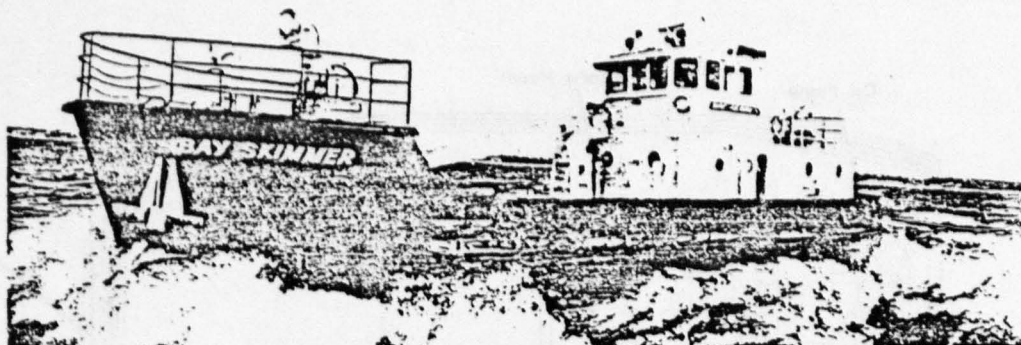

OFFSHORE OIL RECOVERY VESSELS —
100 LT TO 750 LT, OIL STORAGE 10,000 TO 70,000 GALLONS

Double chined displacement hulls amply powered with twin propulsion systems provide high cruising speeds and excellent seakeeping characteristics. The bows are arranged to be opened during oil recovery operations and closed while transiting or operating as work boats and supply vessels.

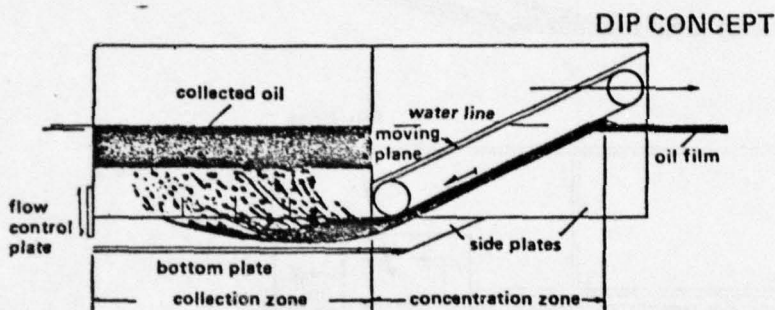

Dynamic Inclined Plane (DIP) Recovery Systems collect oil by forcing it under the surface of the water. Oil follows the surface of the moving inclined plane to a collection well underneath the unit. Buoyant forces cause the oil to naturally separate in the well where it forms a deep oil pocket. Water-free oil is pumped from the top of the well to storage.

UNIQUE FEATURES INCLUDE:

- The ability to harvest any floating material, including debris and sorbents, without changing the recovery system configuration.
- Automatic oil/water separation so that the recovered oil is transferred water free. No water is added by the pickup process.
- A rugged, long-life belt, that uses natural forces to transport the oil to the collection well. No absorbent, or flow-through, principles are required.
- Recovery may be performed at speeds, or in currents, between 0 and 3 knots.
- Excellent performance in waves since the oil is collected under the unit.

JBF SCIENTIFIC CORPORATION

2 Jewel Drive Wilmington, Mass. 01887 Tel. (617) 657-4170

H-11

DIP 2001 REMOTE CONTROL HARBOR SKIMMER

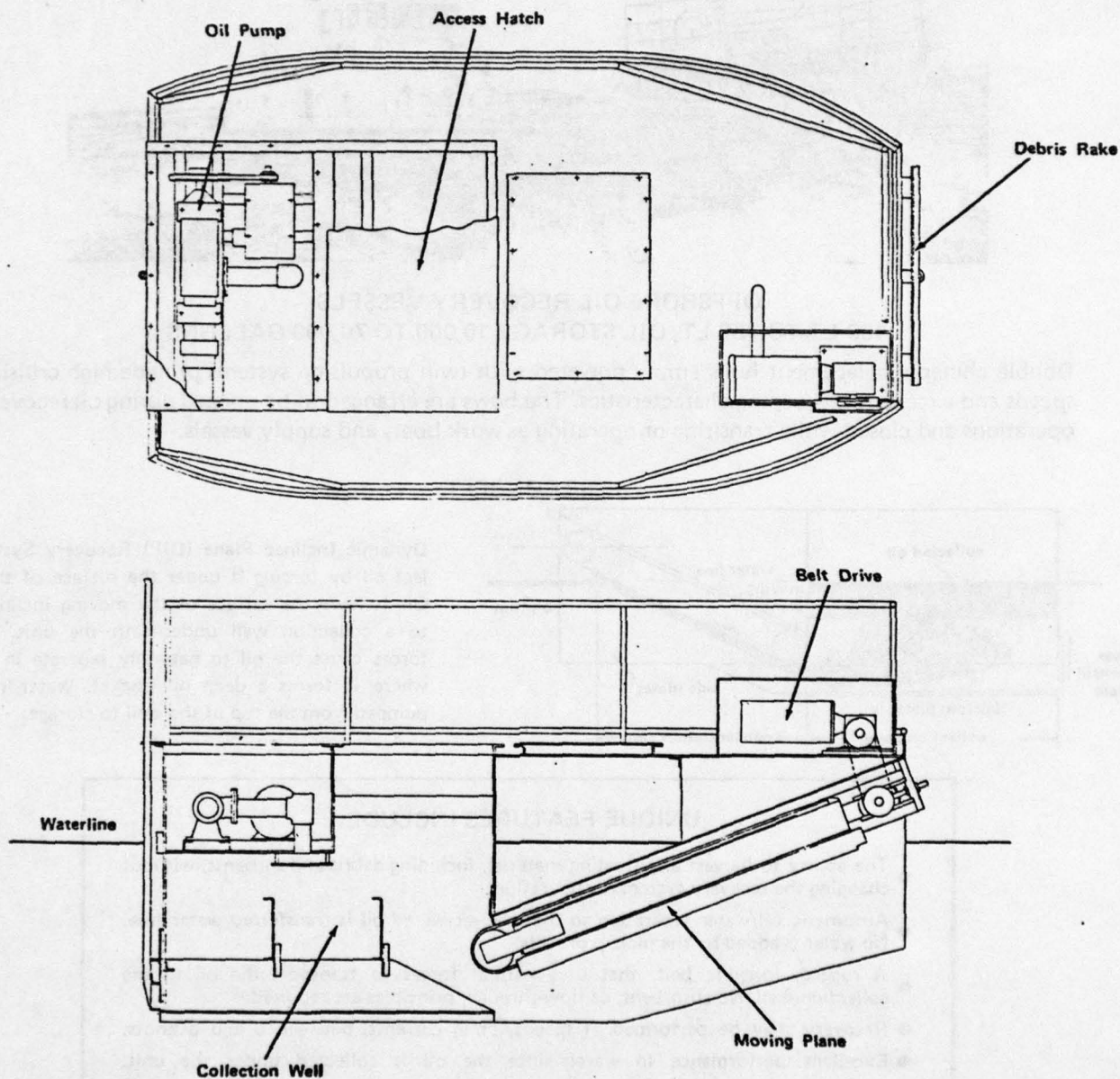

SYSTEM CHARACTERISTICS

Hull	Marine Grade Aluminum	Oil Recovery Rate (2 mm slick)	60 GPM @ 1 knot
Length	13'	% Recovered in one pass	90% @ 1-2 knots
Beam	7'2"	% Water in Recovered Oil	< 1%
Height	6'10"	Effective Oil Collection Speed	0-2 knots
Draft	3'		
Weight	4000 lbs		
Oil Storage	150 U.S. Gallons		

H-12

DIP 3003 LARGE OIL SKIMMER

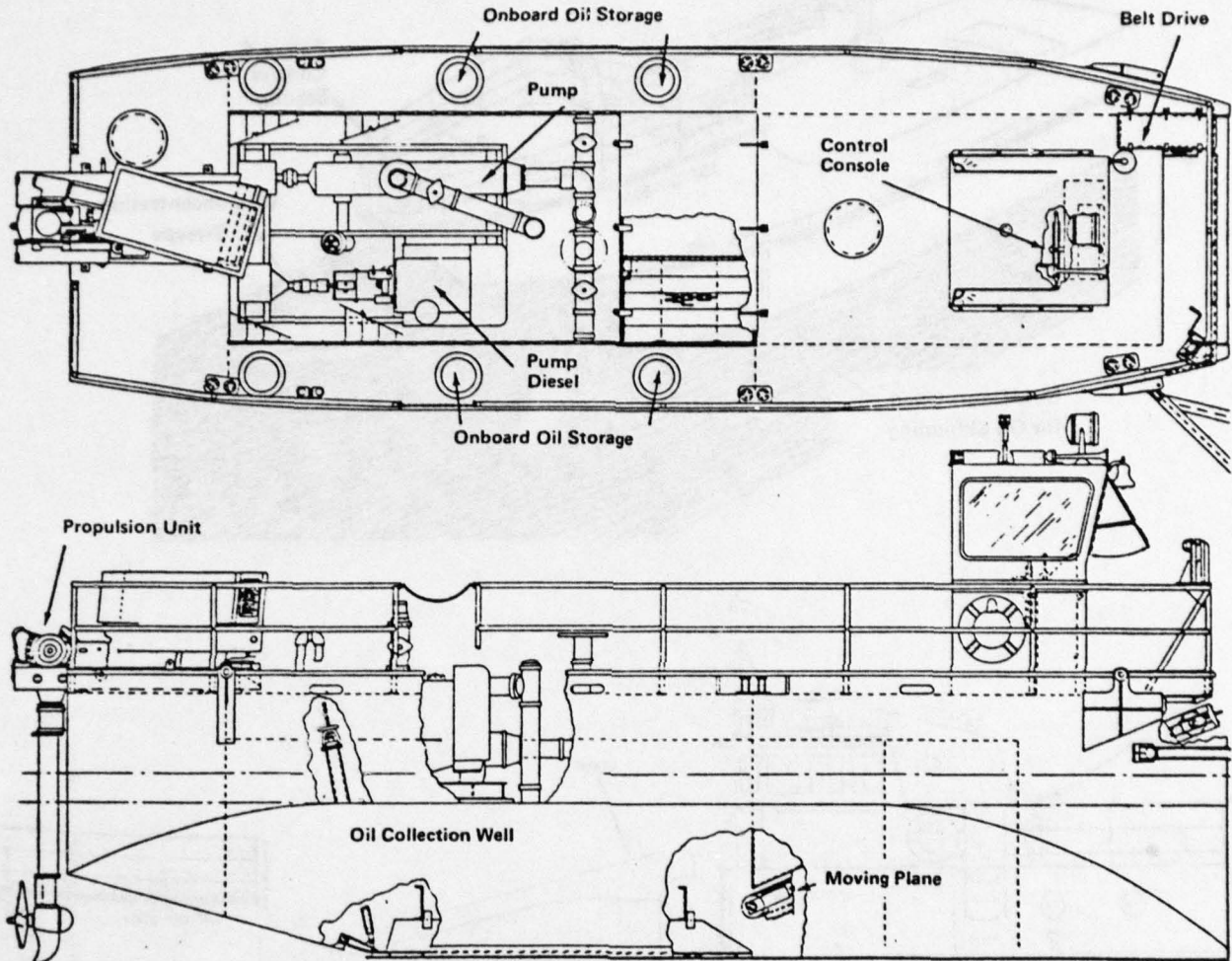

SYSTEM CHARACTERISTICS

Hull	Marine Grade Aluminum
Length	38'
Beam	11'
Draft	4'8"
Weight	16 LT
Oil Storage	4000 US Gallons
Pump	450 gpm

Oil Recovery Rate	450 gpm
% Recovered in one pass	90% @ 1-2 knots
% Water in Recovered Oil	< 1%
Effective Oil Collection Speed	0-3 knots

H-13

JBF DIP 5001

DIP 5001 100 LT OIL RECOVERY VESSEL

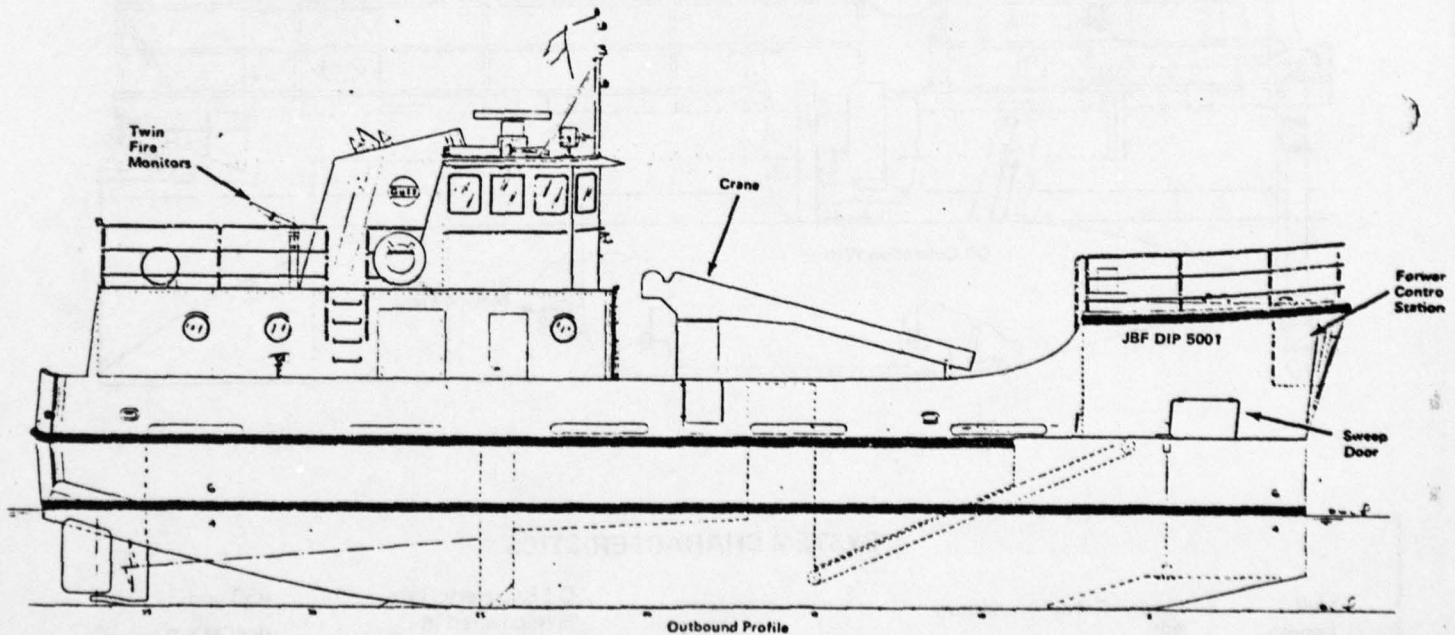
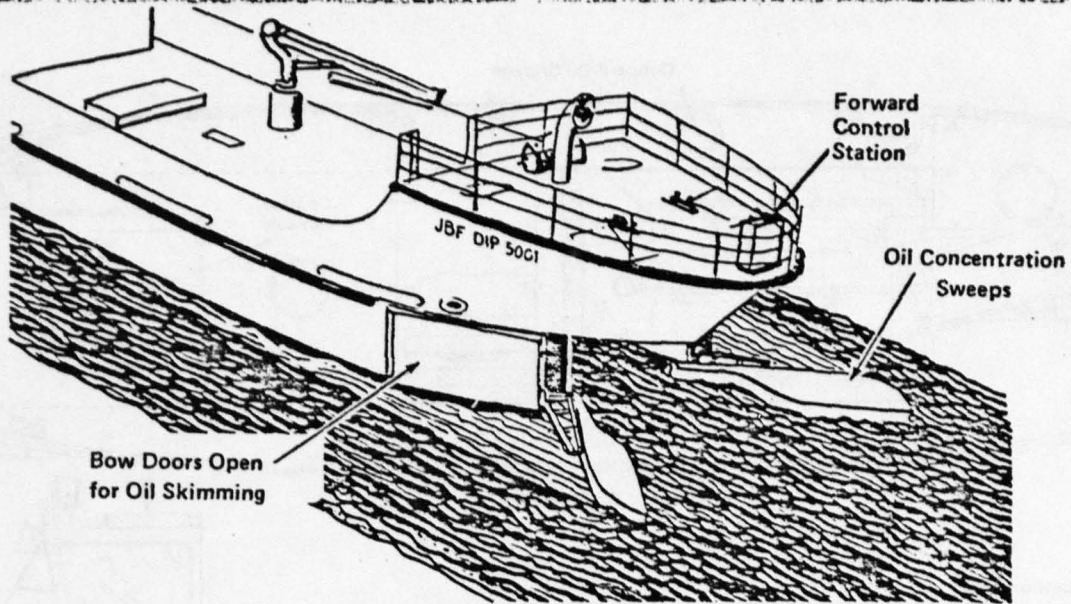

SYSTEM CHARACTERISTICS

Hull	Steel	Draft, Ready for Sea	5'	Electric Power, Each Generator	25 KW
Displacement (Fully Loaded)	100LT	Draft, Full Load	6'	Cargo Capacity	10,000 gal.
Length Overall	68'	Horsepower, Total	500	Recovery Rate	550 gpm
Length, Designed Waterline	65'	Fuel Consumption,		% Recovered in One Pass	90 @ 1-2 kno
Beam, Molded	17'	Full Power	28 GPH	% Water in Recovered Oil	< 1%
Depth, Molded	9'	Cruising Range	300 mi.	Effective Oil Collection Speed	0-3 knots

H-14

OPERATING CONFIGURATION

LOCKHEED OWORS

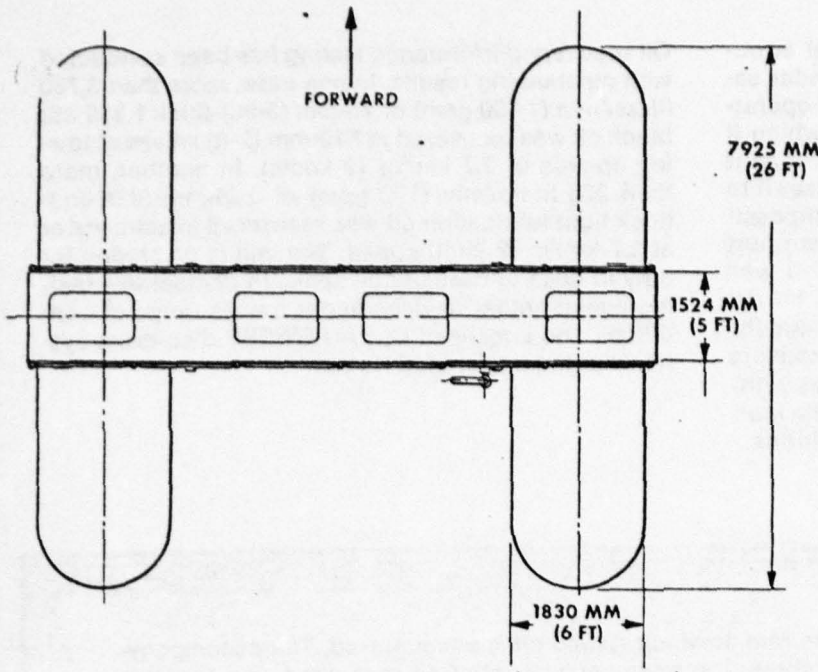

SHIPPING SIZE

2080 MM x 2565 MM x 8534 MM
(6 FT 10 IN. x 8 FT 5 IN. x 28 FT)

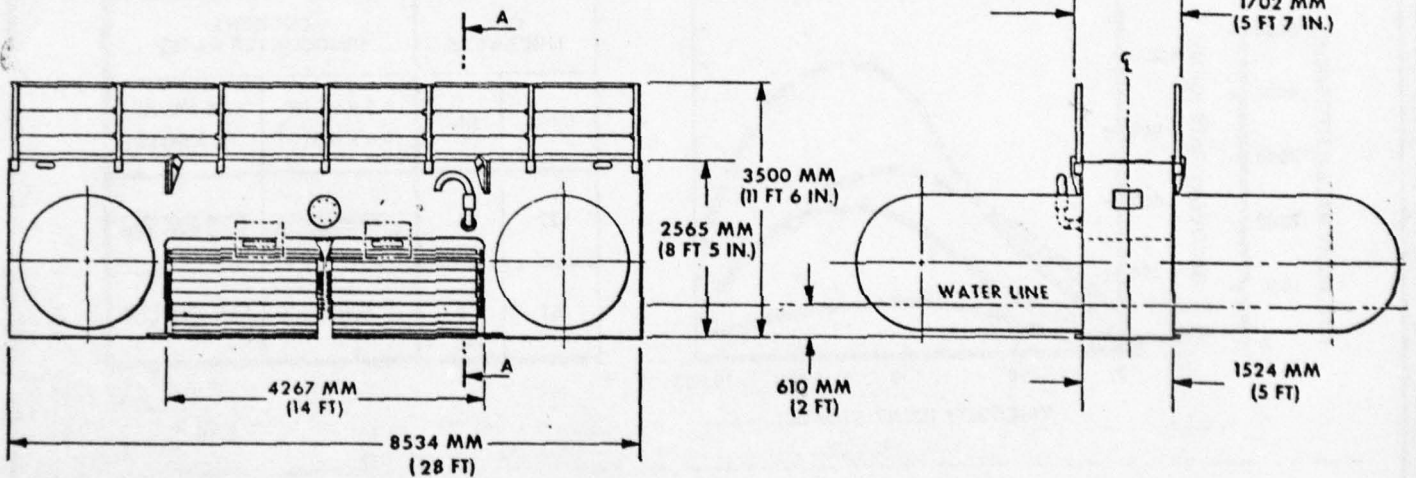
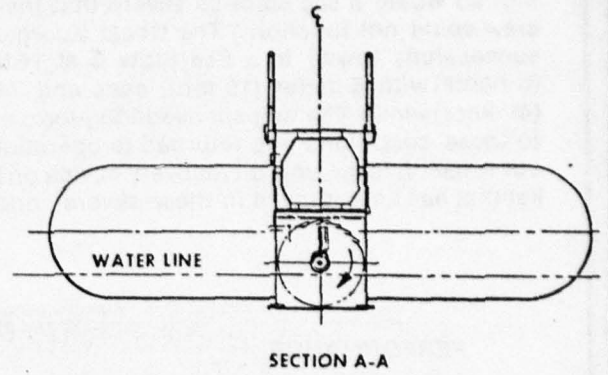

The Lockheed CLEAN SWEEP® Type 4000

For further information concerning the Lockheed CLEAN SWEEP Type 4000
Inert Oil Recovery System, write or phone:

LOCKHEED MISSILES & SPACE COMPANY, INC.

Attn: CLEAN SWEEP Program

P.O. Box 504 Sunnyvale, California 94086

Telephone: (408) 742-5204

Telex: 346409 LMSC SUVL

Ref: 31-73
Aug 1977

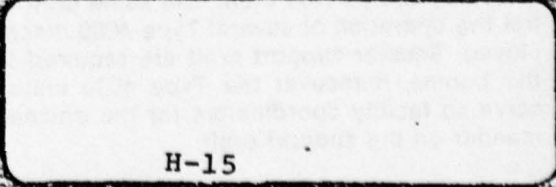

LOCKHEED OWORS (Contd.)

OPERATIONAL TESTING

The CLEAN SWEEP[®] Type 4000 has unusual structural credentials for operation and survival under severe sea conditions. The system is capable of operating efficiently in any North Sea sea state in which it would be expected to recover spilled oil. (A turbulent sea that mixes the oil with the sea water or causes it to sink below the surface would make recovery impossible; so would a sea state so severe that the support crew could not function.) The Coast Guard unit was successfully towed in a Sea State 5 at 14.8 km/hr (8 knots) with 5-meter (16-foot) seas and 74-km/hr (40-knot) winds. The unit survived long-term exposure to these conditions and returned to operations without repair. It is the only oil recovery device on the market that has been proved in these severe conditions.

Oil recovery performance testing has been conducted with outstanding results. In one case, more than 3,780 liters/min (1,000 gpm) of 75-mm (3-in.)-thick 1,500 cSt black oil was recovered in 610-mm (2-ft) waves at towing speeds of 3.7 km/hr (2 knots). In another, more than 378 liters/min (100 gpm) of 0.25-mm (0.01-in.)-thick light lubrication oil was recovered in calm water at 3.7-km/hr (2-knot) speed. The unit is on station for duty in case of casualty oil spills. In competitive testing against other devices under a wide range of conditions, the Lockheed CLEAN SWEEP disc-drum system was the undisputed winner.

PERFORMANCE

Oil recovery performance depends on the rate at which spilled oil is encountered. The accompanying graph, based on extensive test data, shows the optimum amount of oil recovered as a function of current speed, oil layer thickness, and oil viscosity. The operator achieves maximum recovery rates by controlling such variables as drum rotation speed and heading relative to current.

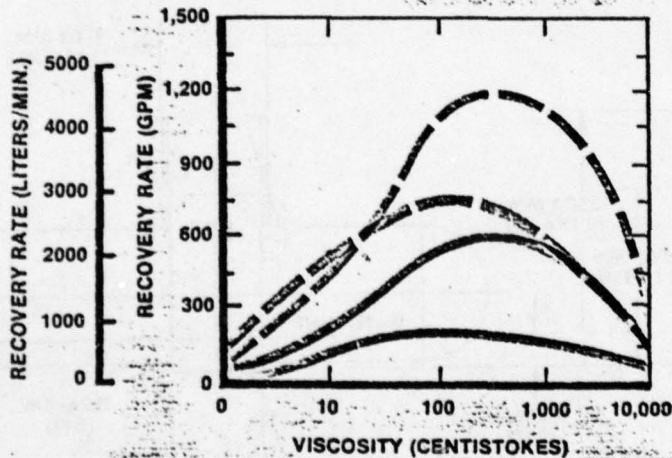

OIL THICKNESS		CURRENT (ENCOUNTER RATE)	
(MM)	(IN.)	0.0 KM/HR (0.0 KNOTS)	1.85 KM/HR (1.0 KNOTS)
127	5		
51	2		

SUPPORT EQUIPMENT

Because the CLEAN SWEEP Type 4000 recovers more than 95 percent oil with less than 5 percent carryover of free water, the system requires no centrifuge or separator. It does, however, need a large-capacity facility to contain the oil it recovers. Under ideal conditions, up to 4,500 liters/min (1,200 gpm) can be recovered at a major spill. This equates to 1,700 barrels per hour or 40,000 barrels per day, which must be stored by the service craft. The same craft can control the operation of several Type 4000 machines deployed. Smaller support craft are required to adjust the booms, maneuver the Type 4000 units, and to serve as facility coordinators for the on-scene commander on the support craft.

CLASS III

58 feet (19 meters) for large bays, harbors, sounds. Three of these skimmers — the most advanced vessels specifically designed and built for oil spill recovery — are manned and ready to go in the major ports of San Francisco and Puget Sound. Uses two Filterbelts to recover up to 600 gpm of oil in a large spill of crude or thick bunker oil. Range 480 miles. Accommodations for crews; operates continuously for days at a time. Has radar, radio, sonar and other navigational equipment. Skims at up to 3 knots. Twin main diesels of 200 hp each drive water jets or optional variable-pitch propellers. Exceptional operating ability at night. On-board heated sumps for 90 bbls; off-loading pumping capacity of 400 gpm. Water spray booms create 45-foot swath. Can carry work boats and more than 1000 feet of containment boom.

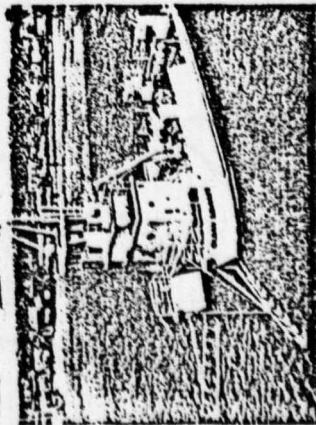

Skimmers that work close to piers and vessels have water spray booms to "sweep" oil to Filterbelt.

CLASS V

36 feet (11 meters) "reversible skimmer" designed for responding in one direction, skimming in the other. Unique design for exceptional maneuverability — turns 360° in-place. Skims at up to 3 knots; can be towed to sea at 12 knots. Skims up to 300 gpm.

This heavy-duty skimmer has been proven to be rugged, reliable in many spills — notably the 2,000,000 bbl Gowanus Ship Canal spill.



Flotilla of Class V skimmers being delivered to Navy support facility from Marco shipyard in Seattle.

Class V can be transported by highway trailer or heavy-lift helicopter; also, a modular version can be shipped via C-130 cargo plane. Nearly 30 Class V skimmers have been delivered to US Navy, major oil companies, port-protection agencies.



Class XI "PetroPack" Skimmer is shipped in packages by any mode for quick assembly on tanker, tug, or workboat. System includes power unit, outrigger spars, collection booms, and skimmer. Each skimmer recovers up to 48 tons/hr.

CLASS VII

50 feet (15 meters) similar in design and operating features to Class V. Larger size permits independent operation in remote areas and faster responding speed; carries 1000 feet of spill containment boom. Has 80 bbl on-board storage capacity. Alyeska has Class VII on duty at Valdez, and Vancouver BC has one for Burrard Inlet protection.

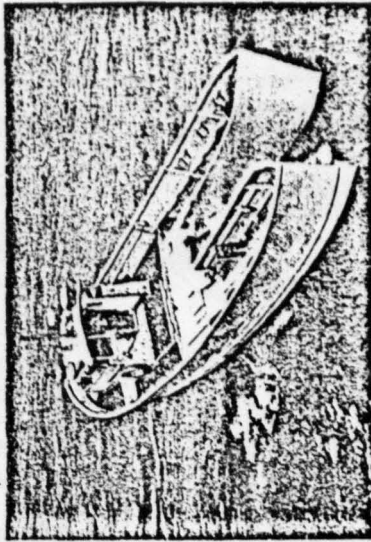

Class VII skimmer can rotate on its own axis, respond at 6 knots, skim at 3 knots.

Both skimmers store recovered oil in sump for off-loading with on-board pumps with sufficient head to reach trailing barge, platform, or tanker. Both skimmers also have large induction pumps behind "Filterbelt" to draw even viscous and weathered products to the recovery unit.



Class X "Satellite" Skimmer is launched from workboat stern like a skiff. Unmanned, radio-controlled, and towed by booms from workboats or tugs. 37 feet (11.2 m). Recovers up to 80 tons/hr.

MARCO SKIMMERS

How the Marco FILTERBELT system operates

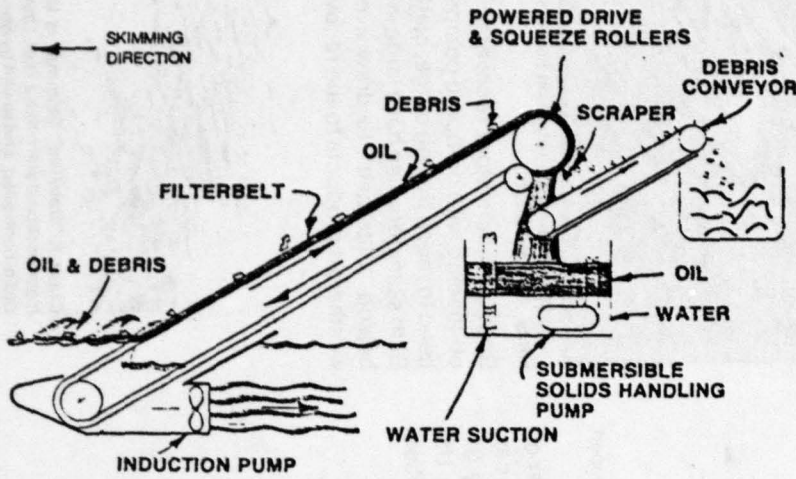

U.S. & FOREIGN PATENTS PENDING

FILTERBELT conveyor mounted between catamaran hulls is a flow-thru system. Water induced by the advance of the skimmer and the force of the induction pump freely passes thru the patented FILTERBELT made of oleophilic porous material with tough nylon and bronze open backing. Oil attached to the strands of the FILTERBELT, and thick oil and debris riding on the FILTERBELT, are conveyed to the deck level, where they are separated and stored for offloading.

Induction pump draws oil to skimmer and FILTERBELT at up to 1 knot while vessel is in stationary mode even in heavy spill; also assists during free skimming.

Waves pass through porous FILTERBELT as oil is entrained; waves are not "reflected" as occurs with solid belt system.

FILTERBELT Oil Recovery Performance Data

Oil recovery rate for a 3' wide Filterbelt

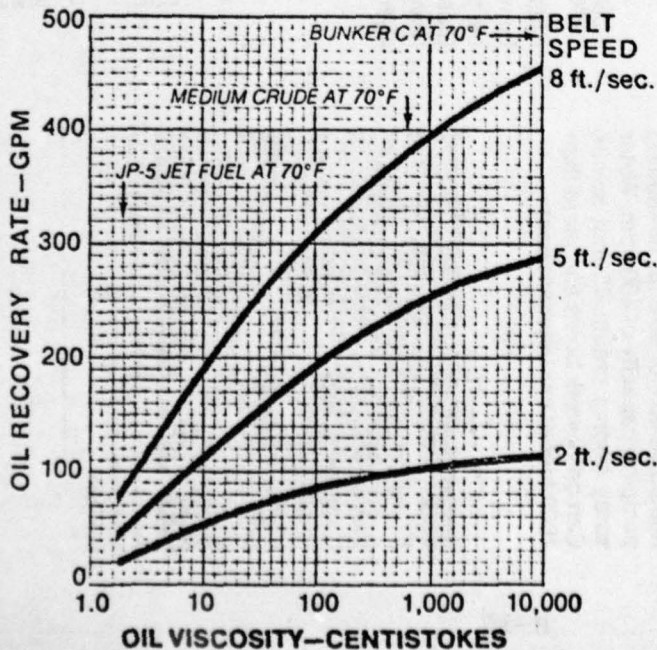

Oil recovery performance is a composite of laboratory and test basin data, confirmed by field experience. Curves are shown for the maximum oil recovery rate (saturation) of the Filterbelt.

Experience has shown that oil encounter rates in open water skimming do not approach the Filterbelt saturation levels due to the rapid spreading of oil into relatively thin slicks on the water surface. Open water recovery rates are usually best determined by slick thickness, sweep width, and sweeping speed.

Where oil is in a thick layer, such as in a containment boom, recovery rates are determined by these curves. Continuous rates are subject to vessel stowage capacity or offloading pumping rate.

Oil recovery is enhanced by moderate waves. Recovery rate for a specific class of skimmer is a function of number and width of belts.

MARCO CLASS V

CONDENSED SPECIFICATION

36' CLASS V OCEAN SKIMMER VESSEL
MARCO DWG. NO. E-226-3-(A)
 MARCH 1976

<u>Particulars:</u>	<u>English:</u>	<u>Metric:</u>
Length O.A.	36'-0"	10.97 m
Beam O.A.	12'-0"	3.66 m
Depth, Md.	5'-1"	1.55 m
Draft, L.S.	2'-11"	0.89 m
Draft, R.F.S.	3'-2"	0.97 m
Draft, Full Load	4'-2"	1.27 m
Height, Overall	17'-0"	5.18 m
Height (Pilot House Top Removed)	8'-11"	2.72 m
Displacement, Light Ship	17,300 lbs.	7,847.3 kg
Displacement, R.F.S.	18,200 lbs.	8,255.5 kg
Displacement, Full Load	37,800 lbs.	17,146.1 kg
Fuel Oil Capacity	70 Gal.	18.5 Liters
Hydraulic Oil Capacity	75 Gal.	19.8 Liters
Sump Tank Capacity	40 BBLs	(40 BBLs)
Induction Pump	16 HP	16 HP

MACHINERY

Main Engine: Detroit Diesel Engine 4-53
 100 HP @ 2400 RPM

Speed, R.F.S., Fwd.: 5 knots
 Speed, R.F.S., Astern: 3 knots

Main Propulsion Unit: Marco T-40 Thruster.
 Full 360° rotation of thruster provides propulsion and steerage.

EQUIPMENT:

Oil Transfer Pumps: One (1) 5" Midland progressive cavity pump rated 200 gpm @ 60 psi.
 One (1) Marco U101 4" submersible trash pump rated 400 gpm @ 30 psi.

Fluid Power Supply: Marco 3-hole 1:1 geared hydraulic pump drive with 5 hydraulic pumps.
 Engine driven 7.5 CFM air compressor.

Air Power Supply: Hydraulically driven 3 foot wide belt unit. Pneumatically actuated squeeze roller.

"Filterbelt" Module: One (1) 36" x 29'-8" x 1" belt.
 "Bunkerbelt" (for heavy oils): One (1) 36" x 29'-8" x 1/8" belt.

NOTE: Specifications subject to change without notice.

H-19

MARCO POLLUTION CONTROL A Division of MARINE CONSTRUCTION & DESIGN CO. Seattle, Washington, U. S. A.	DWG	APP'D	SCALE
	CHK	DATE	
	DWG NO.	E-226-3-(A)	
			

MARCO CLASS VII

CONDENSED SPECIFICATIONS
48' Class VII Ocean Skimmer
Marco Dwg. No. E-234-1-1100-1,-2

<u>Particulars:</u>	<u>English:</u>	<u>Metric:</u>
Length, O.A.	48'-1"	14.66 m
Length, L.W.L.	42'-0"	12.80 m
Beam Molded (at deck)	14'-0"	4.27 m
Beam, Maximum	14'-9"	4.50 m
Depth Molded	4'-6"	1.37 m
Displacement R.F.S.	34000 lbs.	15400 kg
Nav. Draft R.F.S.	4'-4"	1.32 m
Nav. Draft Full Load	5'-5"	1.65 m
Clearance, W.L. to top of Pilot House	14'-0"	4.27 m
Clearance, W.L. to top of Tower	21'-0"	6.40 m
Sump Tank Capacity (42 U.S. gal/bbl)	80 bbls	12700 Liters
Freeboard, R.F.S.	2'-6"	0.76 m
Freeboard Full Load	1'-5"	0.43 m
Gross Tonnage (approx.)	25 tons	(25 tons)
Free Sweep Width	8'-0"	2.44 m
Belt Submergence (R.F.S. @ W.L.)	3'-0"	0.92 m
Induction Pump	16 HP	16 HP
Crew Accommodation/Operators Req. (min.)	2/2	
Fuel Oil Capacity	360 gal.	1350 Liters

Machinery:

Main Engine	Detroit Diesel 6V-53 165 HP @ 2400 RPM
Speed, R.F.S. Fwd.	7.5 knots
Speed, R.F.S., Astern	4.5 knots
Main Propulsion Unit:	One (1) 100 HP thruster, full 360° rotation of thruster provides propulsion and steering.

Equipment:

Oil Transfer Pump:	Midland EH2500 rated @ 400 GPM
Salt Water Wash Down Pump	Hydraulically driven, 100' head
Fluid Power Supply:	Marco 3-hole 1:1 geared hydraulic pump drive with 5 hydraulic pumps
Air Power Supply:	Engine driven 7.5 CFM air compressor
Oil Containment Boom	(2) x 492' ea., self-inflating lightweight containment boom with adapters, bridles and sea anchors
"Filterbelt" Module:	Hydraulically driven 3 foot wide belt unit, pneumatically actuated squeeze roller.
"Filterbelt"	One (1) 36" combination Filterbelt with replaceable pads
Bilge Pump	Clutched centrifugal, self priming

NOTE: Specifications subject to change without notice.

H-20

MARCO POLLUTION CONTROL A Division of MARINE CONSTRUCTION & DESIGN CO. Seattle, Washington, U.S.A.	DESIGNED BY ERG	APPROVED BY DWL	SCALE	
	CHECKED BY DWL	DATE 1-18-76		
	DWG. NO. E-234-1	REV. B		

MARCO CLASS X
CONDENSED SPECIFICATION
37' CLASS X OCEAN SKIMMER VESSEL
MARCO DWG. NO. E-224-10-1A
DECEMBER 1976

SPECIAL CLASS NON-SELF PROPELLED, RADIO CONTROLLED, OCEAN SKIMMERS

<u>Particulars</u>	<u>English</u>	<u>Metric</u>
Length O.A.	36' - 11"	11.25 m
Beam O.A.	19' - 8"	6.00 m
Depth, Md.	6' - 10"	2.08 m
Draft, L.S.	5' - 0"	
Draft, Full Load Approx.	6' - 0"	1.83 m
Height O.A.	20' - 0"	6.07 m
Displacement, Light Ship Approx.	23,500 lbs.	10,675.6 kg
Displacement, Full Load	34,500 lbs.	15,646.3 kg
Fuel Oil Capacity	850 gal.	224.6 liters
Hydraulic Oil Capacity	150 gal.	39.6 liters
Induction Pumps, 2 each	15 HP	15 HP

MACHINERY

Main Engines

Two, Detroit Diesel Engines 3-53. 75 HP @ 2400 RPM.

EQUIPMENT

Oil Transfer Pumps

Two 5" Midland progressive cavity pump rated 200 gpm @ 85 psi.

Fluid Power Supply

Two each Marco 3-hole 1:1 geared hydraulic pump drive with 5 hydraulic pumps.

Air Power Supply

Engine driven 7.5 CFM air compressor.

Filterbelt Modules

Two hydraulically driven 3 foot wide belt units. Pneumatically actuated squeeze roller.

Filterbelt (for light oils)

Two 36" x 29' - 8" x 1" belt.

Bunkerbelt (for heavy oils)

Two 36" x 29' - 8" x 1/8" belt.

Remote Controls

Dual radio controls to activate ship systems from parent vessel.

Cradle

Combination stowage and launching cradle specifically fitted with bolt type clamps and towline fairlead.

Boom Adapters

Marco boom curtain adapters port and starboard for use with oil containment booms.

Lifting Bridle

One point bridle capable of lifting both vessel and cradle at shoreside staging area.

Note: Specifications subject to change without notice.

H-21

MARCO POLLUTION CONTROL A Division of MARINE CONSTRUCTION & DESIGN CO. Seattle, Washington, U.S.A.	DATE APR 15 1976	DWG. NO. E-224-10-1-A	
	APPR. DWL	SCALE ---	
	DWG. NO. E-224-10-1-A	REV. ---	

MARCO CLASS III

CONDENSED SPECIFICATIONS

58' Class III Bay/Sound Skimmer

Marco Dwg. No. E-219-2-1100-1

Particulars:

	<u>English:</u>	<u>Metric:</u>
Length, O.A.	57'-10"	17.93 m
Length, L.W.L.	52'-7.5"	16.04 M
Beam, O.A.	23'-4", 7'4"/hull	7.11 m, 2.23 m/hull
Depth, Mld.	7'-3"	2.21 m
Displacement, R.F.S.	58 L. tons	58.9 m tons
Nav. Draft R.F.S.	4'-11"	1.5 m
Clearance, W.L. to Top Pilot House	24'-0"	7.32 m
Clearance, W.L. to Top Mast	50'-0"	15.24 m
Oil Slops Capacity (42 U.S. gal. barrel)	90 bbls.	(90 bbls)
Approx. Deadwt. Tons	12.6 L. tons	12.8 m. tons
Tons per Inch or cm. Sinkage (saltwater)	1.14 L. tons	1.158 m tons
Approx. Loaded Sinkage	11"	27.94 cm
Trash Storage Capacity (nominal)	378 sq. ft.	35.1 m ²
Freeboard, R.F.S.	3'-3"	1 m
Freeboard 1/2 F.O. and 1/2 water, full slops	2'-6"	0.76 m
Gross Tonnage	47	(47)
Free Sweep Width	16'-0"	3.44 m
Oil Herding Water Spray Boom (sweep width)	34'	10.4 m
Width Between Hulls	8'-8"	2.64 m
Max, Belt Submergence (R.F.S. @ W.L.)	27"	68.6 cm
Induction Pumps, 2 ea. @	16 HP	16 HP
Crew Accomodation/Operators Req. (min.)	2/2	2/2
Fuel Oil Capacity	1040 gals. (U.S.)	3,936 liters
Fresh Water Capacity	30 gals. (U.S.)	113.6 liters

Machinery:

Main Engines, 2 ea. . . .	200 SHP @ 2800 RPM, Caterpillar 3208
Range @ .8 Power	460 n. miles
Propulsion	Hamilton 1341 Jet

Equipment:

Off-Load Pumps, 2 ea. @	250 GPM @ 100' TDH
Bow Thrusters, 2 ea. @	40 HP
Crane, 1 ea.	1400 lbs. @ 32 ft.
Auxiliary Power, 2 ea.	12.5 KW 220/110V A.C.
Filterbelts (No. & Size), 2 ea. @	3' x 29"

NOTE: Specifications subject to change without notice.

H-22

MARCO POLLUTION CONTROL A Division of MARINE CONSTRUCTION & DESIGN CO. Seattle, Washington, U.S.A.	DWG LASSLE DWL	APP'D DWL	SCALE 1/8" = 1' 0"	
	DWG NO. E-219-2	DATE 7/7/76	REV. D	

CONDENSED SPECIFICATION
 22' CLASS XI OIL RECOVERY SYSTEM
 MARCO DWG. NO. E-224-11-1
JANUARY 1977

NON-SELF PROPELLED, REMOTE OPERATED, OCEAN SKIMMER FOR USE WITH VESSEL OF OPPORTUNITY

<u>Particulars</u>	<u>English</u>	<u>Metric</u>
Length O.A.	22' - 0"	6.71 m
Beam O.A.	8' - 0"	2.44 m
Draft, Operating	2' - 7"	.83 m
Displacement, Operating	5,960 lbs.	2,708 kg
Hoisting Weight	3,860 lbs.	1,764 kg
Length Stowed	18' - 1"	5.52 m
Beam Stowed	6' - 1"	6.86 m
Height Stowed	6' - 8"	2.07 m

POWER UNITMachinery

As a unit measuring L-3.05 m, W-1.52 m, H-1.83 m (10'x5'x6') weighing 1445 kg (3400 lbs.).

Diesel Engine
 Gearbox
 Hydraulic Pumps

John Deere Model 4239T. 75 HP at 2000 RPM.
 Marco two pump direct drive, gear ratio 1:1.
 Vickers single pump model 25V17 (26 GPM) and Vickers double pump model V2020-9-6 (14:10 GPM).

EQUIPMENT

Flotation Cell	Rugged, multi-compartment, reinforced rubber buoyancy chamber of 70 mm diameter (28").
Oil Transfer	Variable speed hydraulic, two-lobe positive displacement pump, Tuthill model 330, rated at 38 tons/hour at 15 m head, capable of handling 1" solids.
Recovery Hose Connection Kit	As a unit measuring L-3.35 m, W-1.83 m, H-.61 m (11'x6'x2') and weight of 709 kg (1565 lbs.) containing hydraulic hoses, oil discharge hoses, and spares and repair parts.
Filterbelt Module	Hydraulically driven 3 foot wide belt unit with hydraulically actuated squeeze roller, including hydraulic drive induction flow pump.
Control Station	Incorporates power unit and skimmer unit controls, gauges and instruments.
Air Compressor	Low pressure 12V electrically driven to inflate buoyancy cell.
Storage Pallets	Raised wood pallets suitable for forklift transport.
Lifting Bridle	Four corner single lift bridle for use with power unit, vessel and hose connection kit.
Boom Connectors	Welded aluminum U.S. Navy type for standard Navy Oil Diversion Boom.

Note: Specifications subject to change without notice.

H-23

MARCO POLLUTION CONTROL A Division of MARINE CONSTRUCTION & DESIGN CO. Seattle, Washington, U.S.A.	DWG RRM	APP'D DWL	SCALE	
	DATE 1-15-77	REV		
	DWG NO. E-224-11-1			

OIL MOP ZRV

DYNAMIC SKIMMER

PAT. PENDING

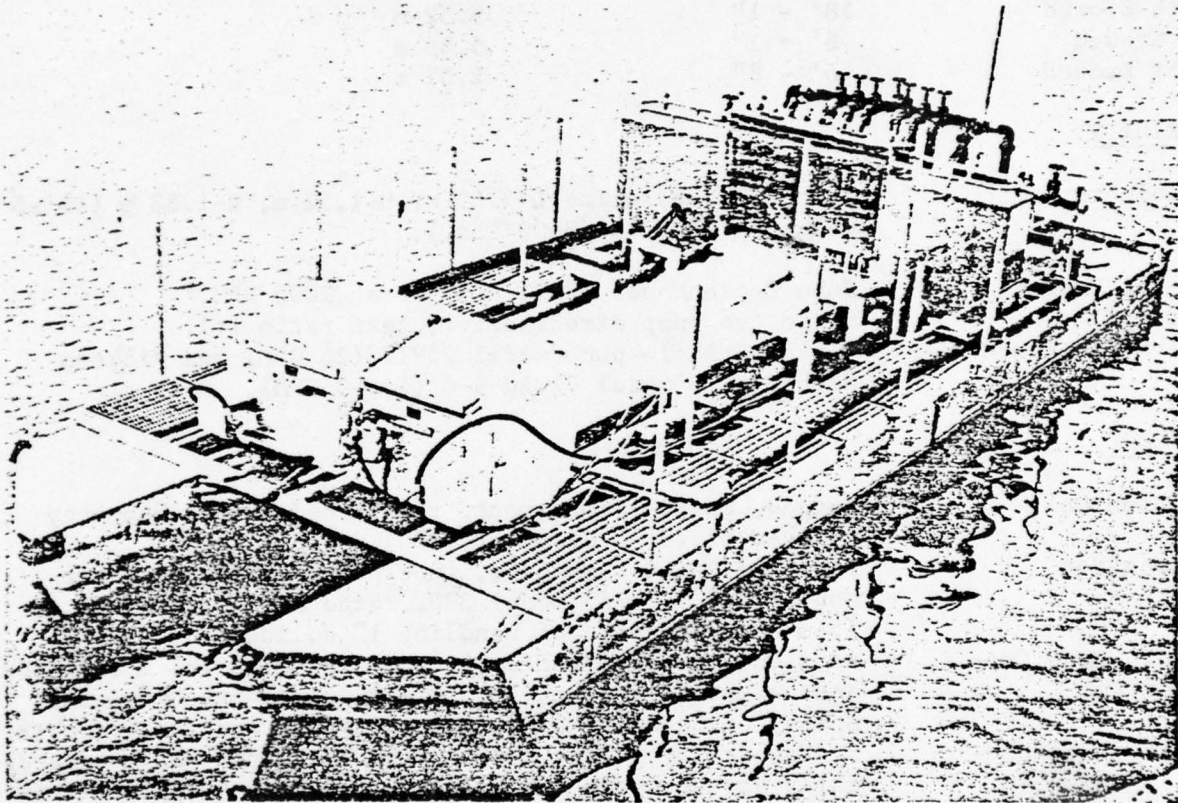

RECOVERY RATE	250 BBL/HR
RECOVERY SPEED	6 KNOTS
STORAGE CAPACITY	2400 GAL. 9,080L
PUMPING CAPACITY	400 BBL/HR
TRAVEL SPEED	15 KNOTS
LENGTH	38' 2" 11.6M
WIDTH	12' 2" 3.7M
SHIPPING WEIGHT	20,000 LB. 9,072KG

OIL MOP Inc.

Engineers Road, Post Office Drawer P, Belle Chasse, La. 70037, U.S.A.

24 hour telephone—(504) 394-6110, Cable address—OILMOP, NEW ORLEANS, Telex - 58 7486



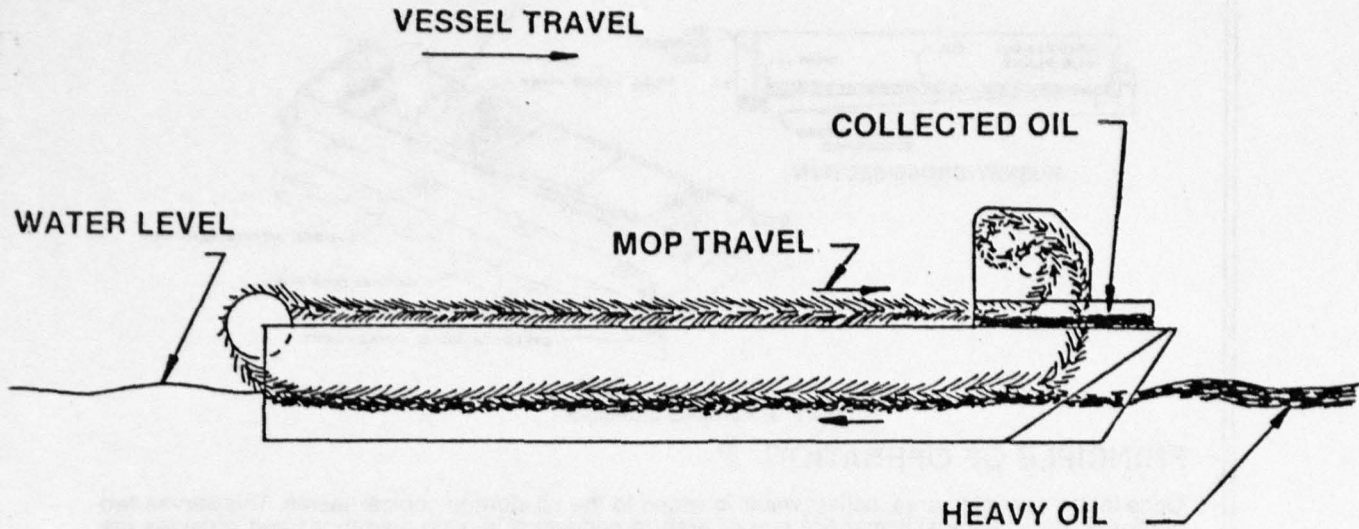

The Oil Mop Dynamic Skimmer Recovery System is based upon the concept of moving an absorbent floating rope mop in the opposite direction of vessel travel. This makes the relative velocity between the mop and the water's surface equal to zero thus allowing the vessel to travel at a high speed while recovering a significantly large amount of oil. As the vessel moves through the water a series of continuous loop rope mops are laid in the calm water at the bow of a catamaran hull. The mops are pulled to the stern as oil is absorbed on the fibers due to the selective surface tension between fiber and oil. The oil soaked mop travels back to the powered rollers in a trough where it is squeezed and the oil is collected.

OTHER FEATURES OF THE OIL MOP DYNAMIC SKIMMER

- The unit can be dismantled and stored in two standard 20' containers for easy transportation by truck or air.
- The unit has a large total pick-up rate. In theory each mop can pick up over 40 BBL's an hour or a total of 250 BBLs/hr for the 40' model with two (2) Mark II-9H's.
- The unit is not affected by debris or ice in the water. The rope mop travels over and around objects absorbing the oil from them but not removing them from the water.
- Sea conditions do not affect the pick-up rate. The rope mop floats on the surface following the contours of the waves, which passes through the catamaran hull undisturbed.
- Since the recovery machinery is separate from the catamaran, it does not require a specialized hull. The vessel is available for other purposes such as fire fighting, line handling, and general utility boat.

HUSKEY OFFSHORE SKIMMER

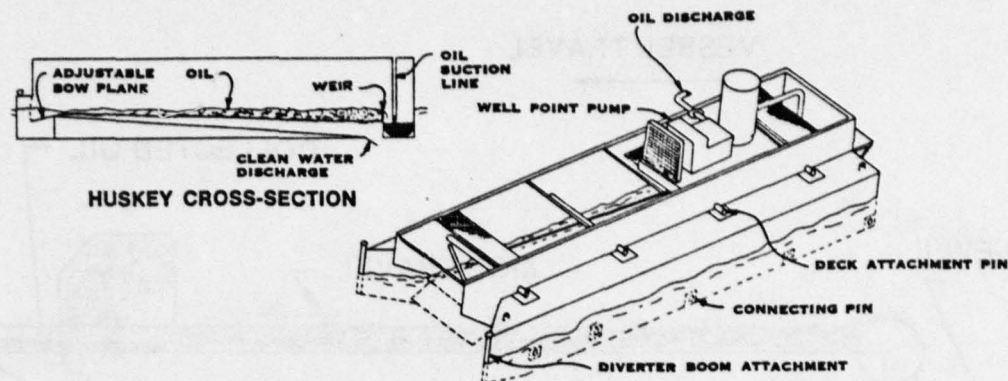

HUSKEY OFFSHORE SKIMMER

PRINCIPLE OF OPERATION

Once in the operating area, ballast water is added to the oil storage compartments. This serves two purposes: It gives the skimmer the proper draft to conduct skimming operations and provides the skimmer with the necessary stability to operate in up to 5-foot waves. Fine trim of the skimmer is provided by ballasting the forward and aft trim tanks located in each pontoon.

In operation, the gathered oil and water flow into the skimmer over the bow plane, which is adjusted so as to prevent any oil from escaping beneath the skimmer. As the oil and water enter the skimmer and flow along the skimmer's sloping floor, flow velocity and turbulence decrease rapidly, facilitating the natural separation of the oil and water. The floating oil spills over the adjustable weir into a sump, while the clean sea water is discharged through a slot in the skimmer's hull.

The skimmer's pumping system picks up the oil from the sump and transfers it to a tanker barge or floating fabric storage tank towed behind the skimmer.

SPECIFICATIONS

Length (LWL)	39 Ft 6 in	12,040 mm	Displacement (ballasted 3 Ft 914 mm draft)	57,600 lbs	2,130 KG	
	(LOA)	42 Ft 3 in	12,878 mm			
Width	(Overall)	16 Ft	4,77 mm	Weight (dry)	29,800 lbs	13,520 KG
	(Disassembled)	8 Ft	2,38 mm			
Height	(Hull)	7 Ft 1 in	2,59 mm	Permanent Foam Flotation	40,900 lbs	18,550 KG
	(Top of Pump)	10 Ft 2 in	3,99 mm			
Draft		3 Ft	14 mm			

OTHER SEAWARD INTERNATIONAL PRODUCTS

SEA CUSHION—Marine Fenders
 SEA FLOAT—Anchor Pendant Buoys
 SEA COLLAR—Hose and Hawser Floats
 SEA FLOAT—Utility Floats
 SEA CURTAIN—Oil Containment Barrier
 SLURP—Oil Skimmer
 SPILTROL HARBOR SKIMMER
 SPILFIGHTER—Dispersant Applicator
 WSL SPRAY BOOM—Dispersant Applicator
 STOPS—Tanker Pumping System & Services

A3M977



SEAWARD INTERNATIONAL, INC.

MAIN OFFICE:

6269 Leesburg Pike
 Falls Church, Va. 22044
 Phone: (703) 534-3500
 Telex: 899-455

MANUFACTURING PLANT:

P.O. Box 98
 Clearbrook Industrial Park
 Clearbrook, Va. 22624

DISTRIBUTED BY:

Early arrival and deployment of containment, skimming, and cleanup equipment can help limit the area affected by an offshore oil spill and reduce overall damage.

With this in mind, a device has been designed by Shell Development Co.'s transportation research and engineering department to combine reasonably high recovery with good maneuverability and low cost. The equipment, called spilled oil cleanup kit (Sock), utilizes currently available technology for the most part and consists of components portable enough to fit on any work boats and supply boats that might be available for quick response to a spill.

Major components of the Sock skimmer when deployed are shown in Fig. 1. The units can be used on both sides of the vessel, or one can be used alone on either side. The prototype kit includes the following components:

- **Sock.** The actual oil skimming device is a one-piece, nylon-reinforced nitrile rubber unit employing a wave damper, an oil collector, and multiple (integral) suction ports for oil recovery. Dimensions are 25 ft wide and 43 ft long, with a draft of 4½ ft.
- **Floating frame.** The lightweight aluminum frame supports the forward end of the Sock and maintains its opening. It also provides a solid structure for attaching the forward tow lines. The frame allows the Sock to roll and pitch independently of the vessel.

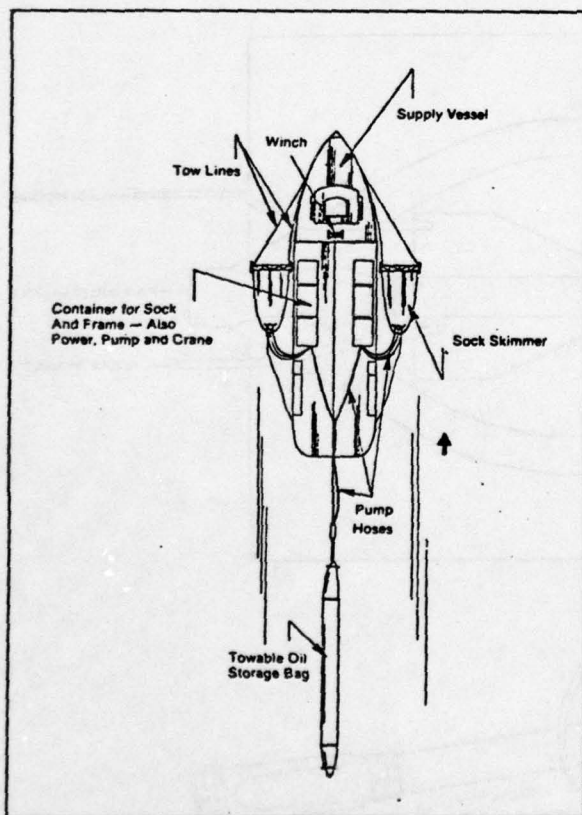

Fig. 1. Deployment of Sock skimmer kits from a supply vessel.

- **Crane.** A 70,000 ft-lb hydraulic crane is permanently mounted at one end of each kit to facilitate assembly and deployment.
- **Pump and power unit.** A 60 hp air-cooled diesel engine provides hydraulic power to the crane and to the 330 gpm rotary positive displacement pump used for oil recovery and transfer.
- **Container.** This has the standard dimensions and fittings of a 35 ft cargo container. It also serves as a foundation for the crane, pump, and power unit. It can also double as an oil-water separator.
- **Towable bags.** In the event of a large spill, oil drawn from the top of the oil-water separator can be piped to commercially available towable bags for temporary storage. Bags increase the drag on the vessel and actually improve its slow speed maneuverability.

A key component of the Sock is the flexible boom-skimmer (Fig. 2). As the Sock is towed, flow is right to left and then downward and out of the open bottomed stern portion. The 4½ ft deep sidewalls of the Sock act as a conventional boom in concentrating the oil. A flexible boom in the forward part of the Sock is attached to the top by rope ties. Because integral flotation in the top cover constrains the top to lie flat, the bottom remains nearly parallel. The interconnected forward part of the Sock dampens high frequency components of the wave surface.

Unlike a draped boom, Sock has a top, which is useful near the stern because it avoids a free-surface air-oil interface. The oil is constrained by the top, which allows suction directly from the oil layer.

Sock is not intended to replace special purpose skimmer vessels. When stored on platforms, however, Sock kits should be able to respond more quickly to an offshore oil spill than skimmer vessels berthed in protected harbors. And, the kit form requires little maintenance when not in use, and is expected to permit rapid transport to remote locations.

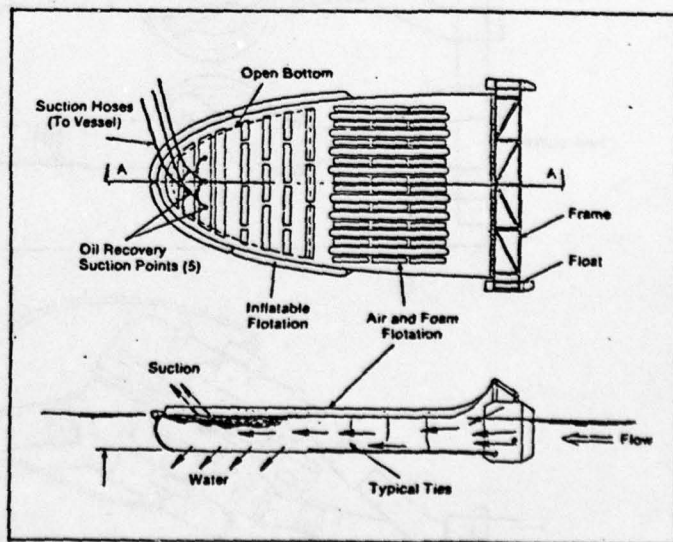

Fig. 2. The actual oil skimming device.

USCG SKIMMING BARRIER

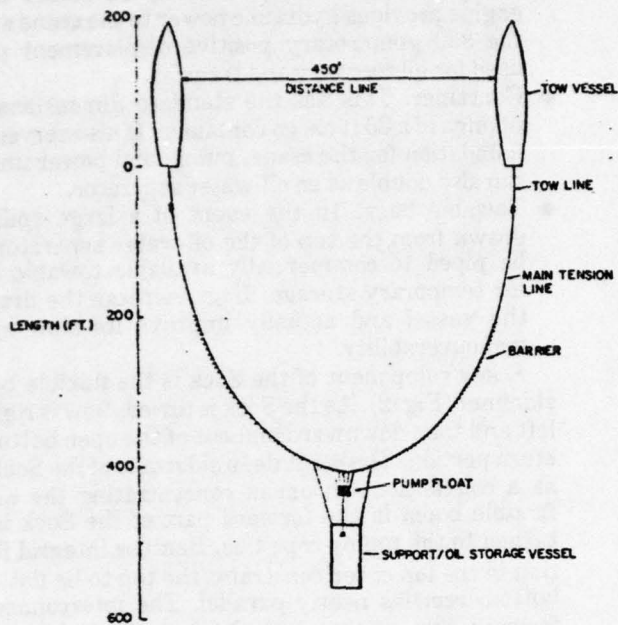

Figure 7. Schematic of typical tow arrangement with skimming barrier

The skimming barrier is one of the most straightforward, simple, and effective systems that has yet been developed for use on the high seas. Its simplicity is a major advantage for use offshore. Deployment of barrier and skimmer are simultaneous and no more difficult than deployment of a barrier alone. The skimmers have no moving parts which would be difficult to maintain in the expected environment. The pumping system needs no priming, can pass debris, and has the low surface speeds required for minimum emulsification.

Reference: Milgram, J.H. and R. A. Griffiths, "Combined Skimmer-Barrier High Seas Oil Recovery System," Proceedings 1977 Oil Spill Conference, New Orleans, March 8-10, 1977.

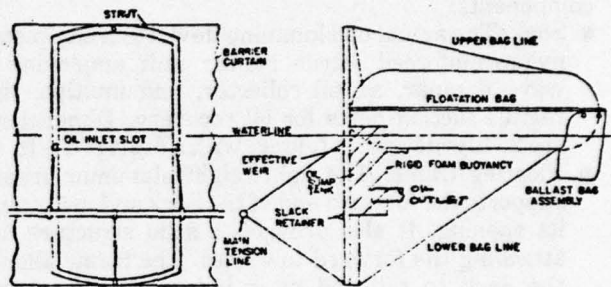

Figure 4. Production design of single weir skimming strut

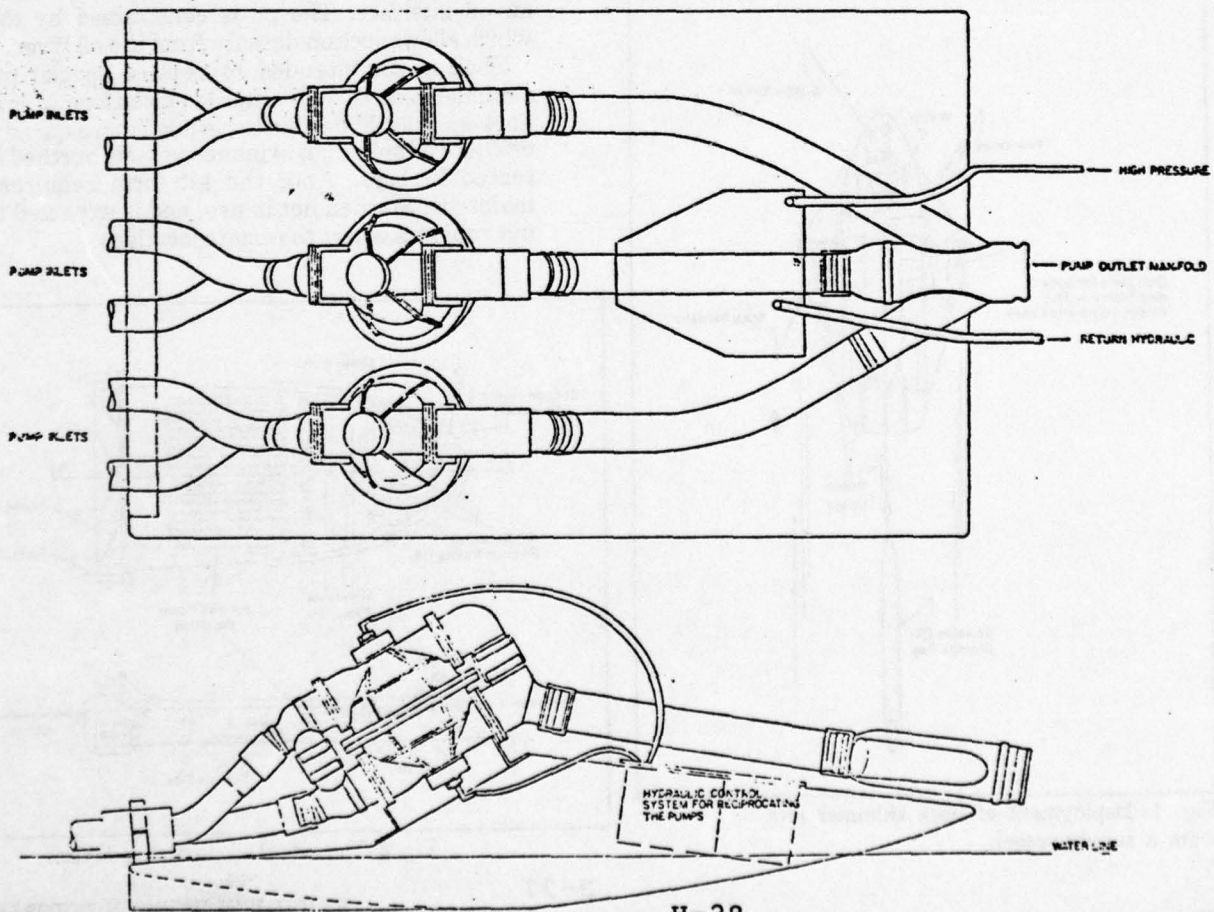

Figure 5. Pump float with three hydraulically-driven double-acting diaphragm pumps

VIKOMA SEASKIMMER

VIKOMA SEASKIMMER

FOR COLLECTION OF
OIL SPILLS AT SEA

Although other disc skimmers have been produced, the VIKOMA SEASKIMMER is the only one to employ toroidal disposition of the rotating discs. This ensures that oil is picked up through 360° and creates a flow of oil towards the skimmer. Oil adheres to the partially submerged discs and is scraped off and transferred through ducts to a collecting bowl for disposal.

For routine SEASKIMMER inspection, access is provided through the top cover and rotor. Maintenance requirements are minimised by use of non-corrodible materials. A single disc can be removed in 15 seconds, and all 80 discs may be removed or refitted in only 20 minutes. SEASKIMMER is easily lifted by its single lifting point and is of compact design with exceptional stability.

SEASKIMMER is powered hydraulically from its remote power pack via hoses which gives separate flow and pressure control of the drive and pump motors. When SEASKIMMER is operating at its maximum recovery rate its weight increases significantly. The power pack therefore also supplies compressed air to an automatic buoyancy control which maintains optimum depth of the pick-up discs.

The mechanical reliability of SEASKIMMER has been amply demonstrated. In endurance tests it has been run continuously for over 250 hours without any deterioration in mechanical performance or operating efficiency. It is insensitive to floating debris.

SEASKIMMER is supplied with detailed handling and maintenance instructions. A complete spares service is available together with technical advice on all aspects of oil pollution abatement.

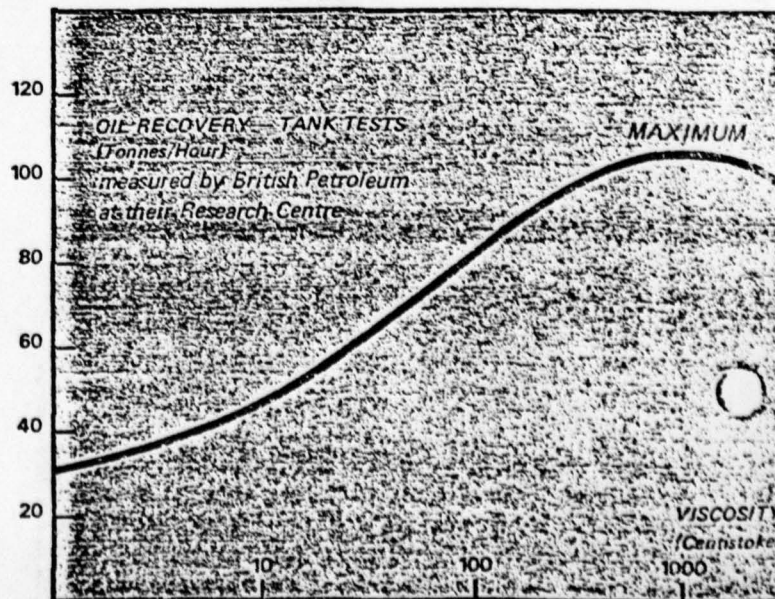
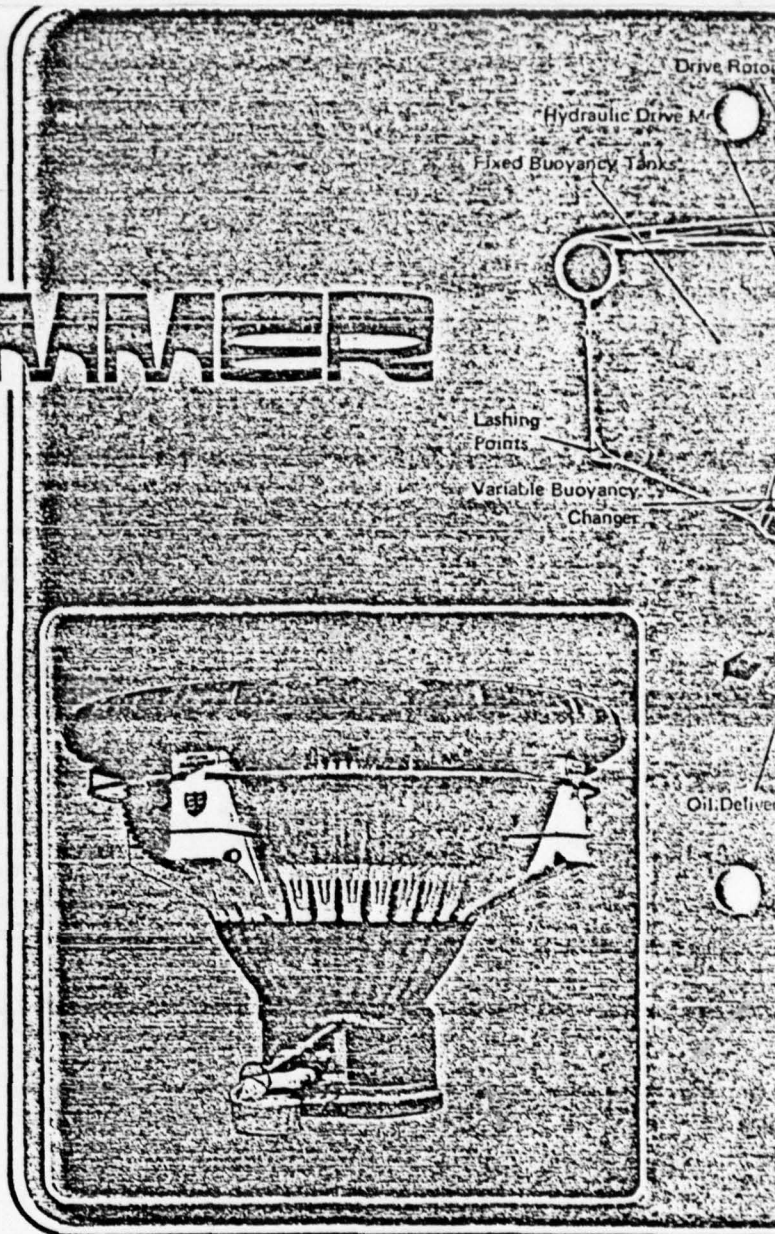

SKIMMER UNIT (A)

DIMENSIONS

Height	8ft 4in. (2.54m)
Outside Diameter	11ft 0in. (3.37m)
Outside Diameter (excluding Fender)	10ft 1in. (3.08m)
Diameter of Base	4ft 9in. (1.22m)
Diameter of Discs	2ft 8in. (0.82m)
Oraght of Discs	7in. (0.18m)
Packing Crats	
Height	8ft 7in. (2.65m)
Base	10ft 4in. (3.15m) square

WEIGHTS

Dry Weight	2200 lb (1000 kg)
Available Buoyancy below Waterline	3450 lb (1565 kg)
Fully Flooded Buoyancy	3320 lb (1505 kg)
Shipping Weight	3460 lb (1570 kg)

POWER PACK (B)

DIMENSIONS (including Protrusions)

Height	4ft 3in. (1.3m)
Width	2ft 9in. (0.84m)
Length	6ft 11in. (2.1m)

WEIGHTS

Dry Weight	2200 lb (1000 kg)
Fuelled Weight	2450 lb (1110 kg)
Shipping Weight	2260 lb (1025 kg)

OUTPUT

Maximum Skimmer System Pressure	3500 lb/in ² (240 bar)
Maximum Output Drive Circuit	8.8 gal/min (40 litres/min)
Maximum Output Pump Circuit	14 gal/min (65 litres/min)
Maximum Auxiliary Circuit Pressure	3500 lb/in ² (240 bar)
Maximum Output	6.6 gal/min (30 litres/min)
Maximum Air Pressure	30 lb/in ² g (5.5 bar)
Delivery	6 ft ³ /min (0.16 m ³ /min)

DECK MOUNTED PALLET WITH POWER PACK AND LIFTING JIB (B + C)

OVERALL DIMENSIONS

Height	6ft 9in. (2.06m)
Width	7ft 6in. (2.29m)
Length	10ft 4in. (3.16m)

BASE

Width	6ft 0in. (1.83m)
Length	10ft 4in. (3.16m)

WEIGHTS

Crane Jib	2360 lb (1070 kg)
Pallet	1335 lb (605 kg)
Power Pack	2450 lb (1110 kg)
Total Weight	6145 lb (2785 kg)
Shipping Weight	6400 lb (2905 kg)

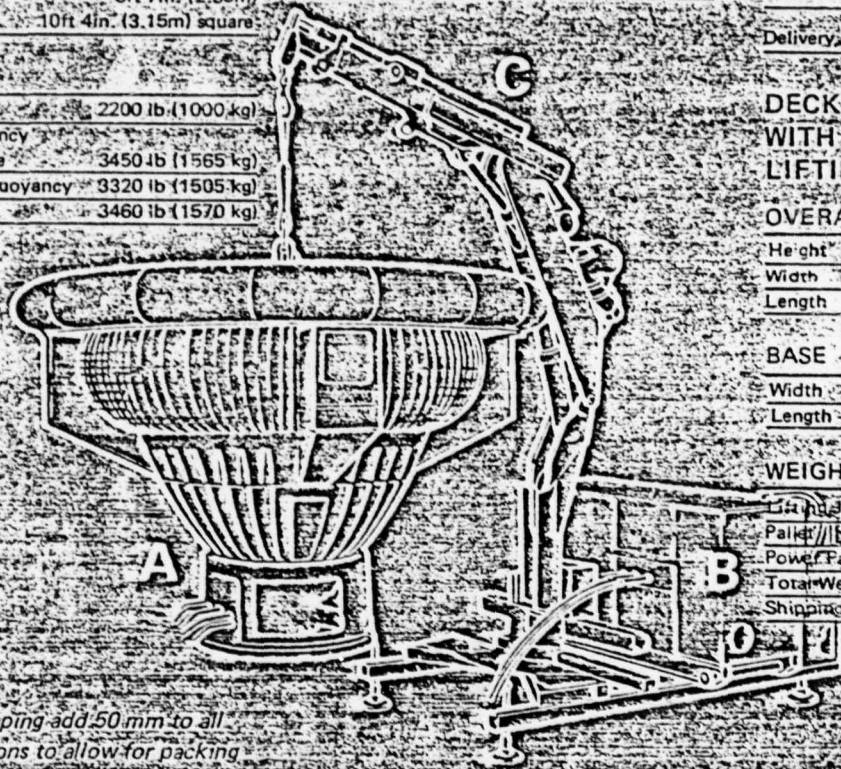

For shipping add 50 mm to all dimensions to allow for packing

THIS PAGE IS BEST QUALITY REPRODUCED FROM COPY MADE BY THE COMPANY TO DBO

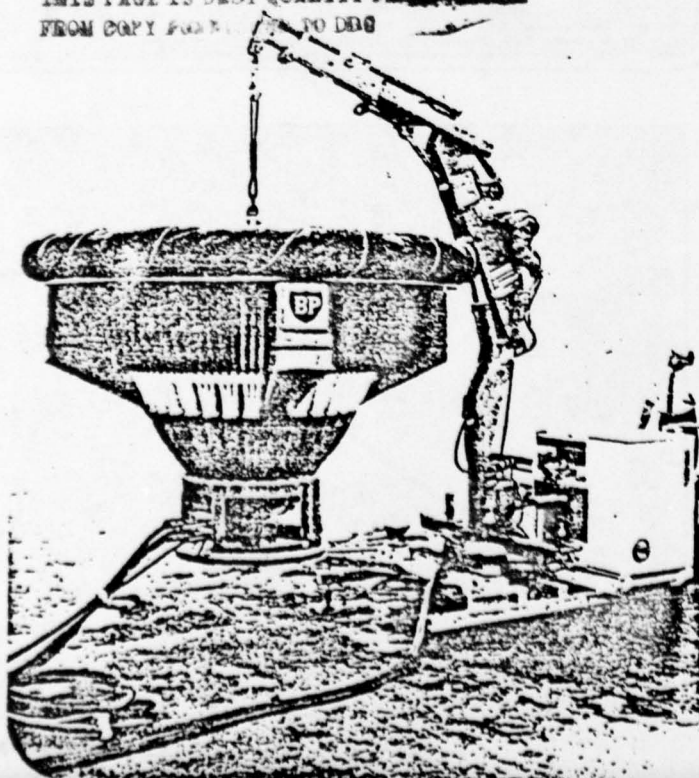

We reserve the right to alter the specification of this equipment without prior notice.

VIKOMA Oil-spill Clearance Equipment is manufactured under licence from BP TRADING LIMITED

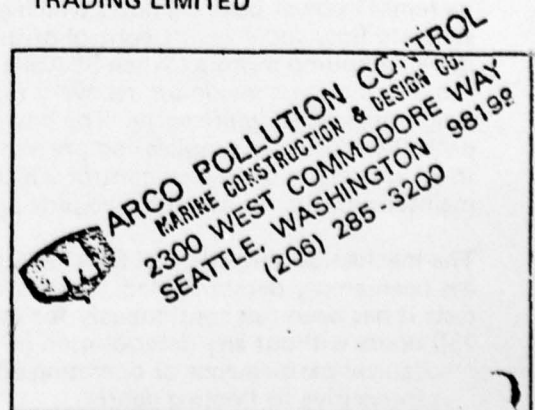

VIKOMA, SEAPACK, SEABOOM and SEASKIMMER are Trademarks of the British Petroleum Company.

Oil Containment Booms
B

MT 2000 boom

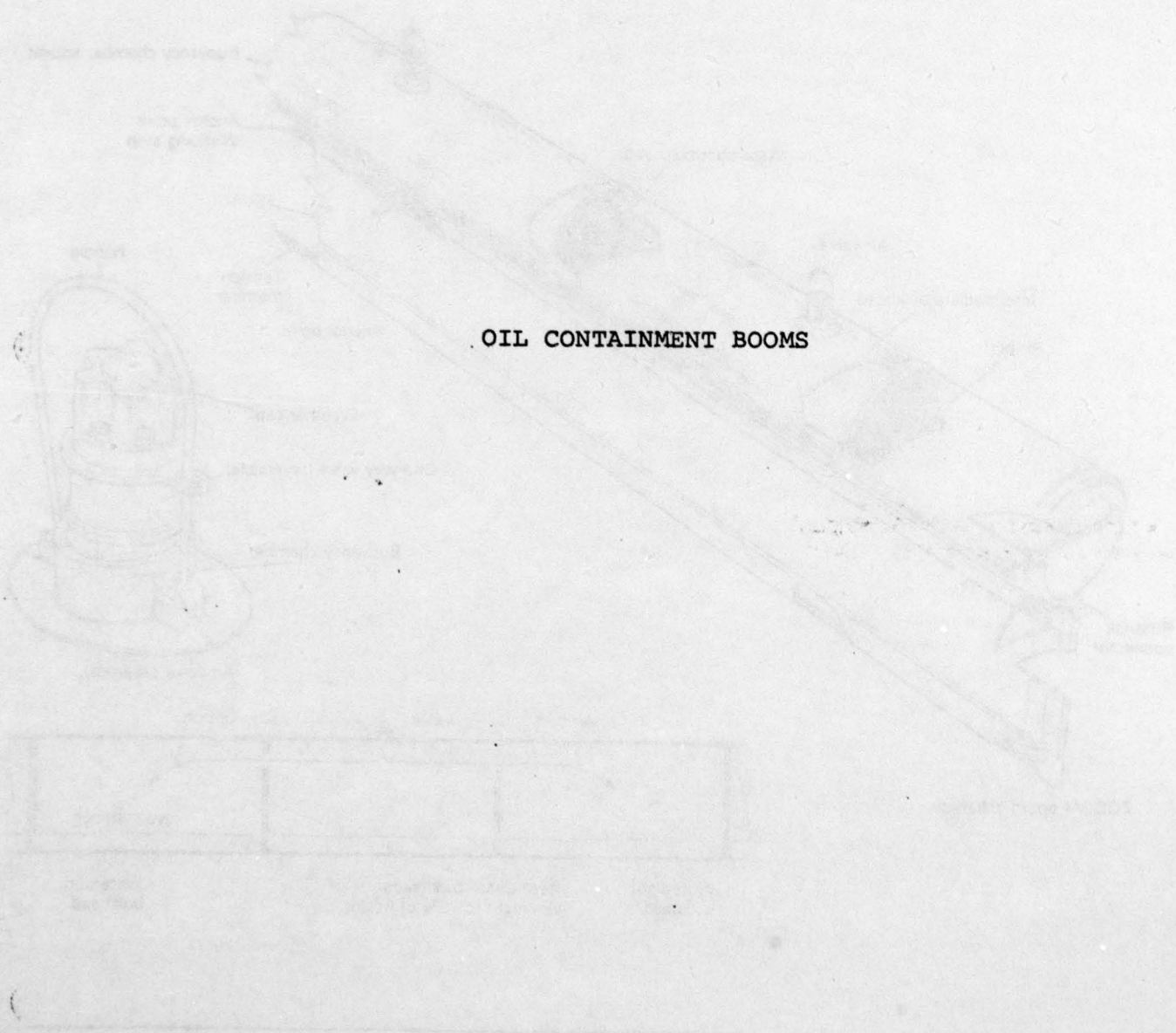

OIL CONTAINMENT BOOMS



bennett pollution controls

ZOOM™ boom

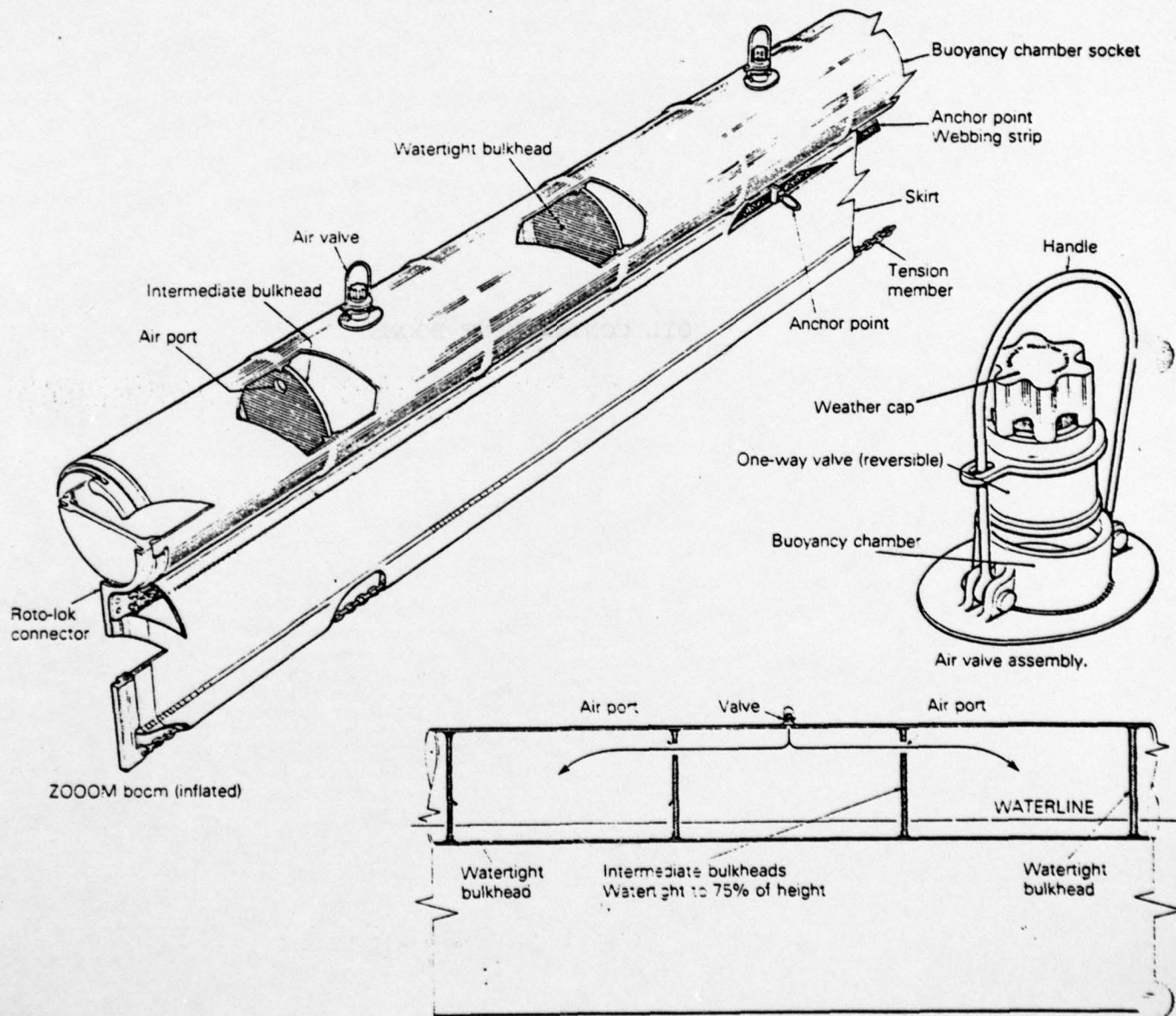

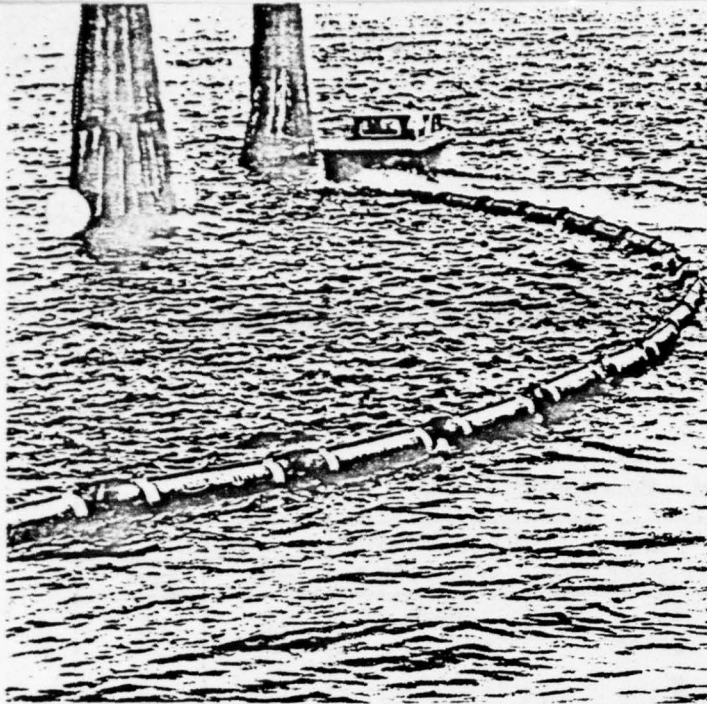

THE SEA SENTRY® 12-24 BOOM for open waters

The Sea Sentry 12-24 oil boom is recommended for pier areas and open water where waves and currents are fairly rough. Each section has a 12" freeboard and a 24" impermeable skirt. The 12-24 is equipped with handles on top and bottom for ease of handling. There are five floats on each section—each with a double air chamber. In case of damage to one side of a float, the second chamber offers enough buoyancy to maintain freeboard until the unit is repaired. Bright orange stripes on each end of each float provide high-visibility warning of the boom installation. Quick-connect air valves fit all standard pumps. An optional 30" open mesh nylon net skirt is available for installation where extensive vortexing is a problem.

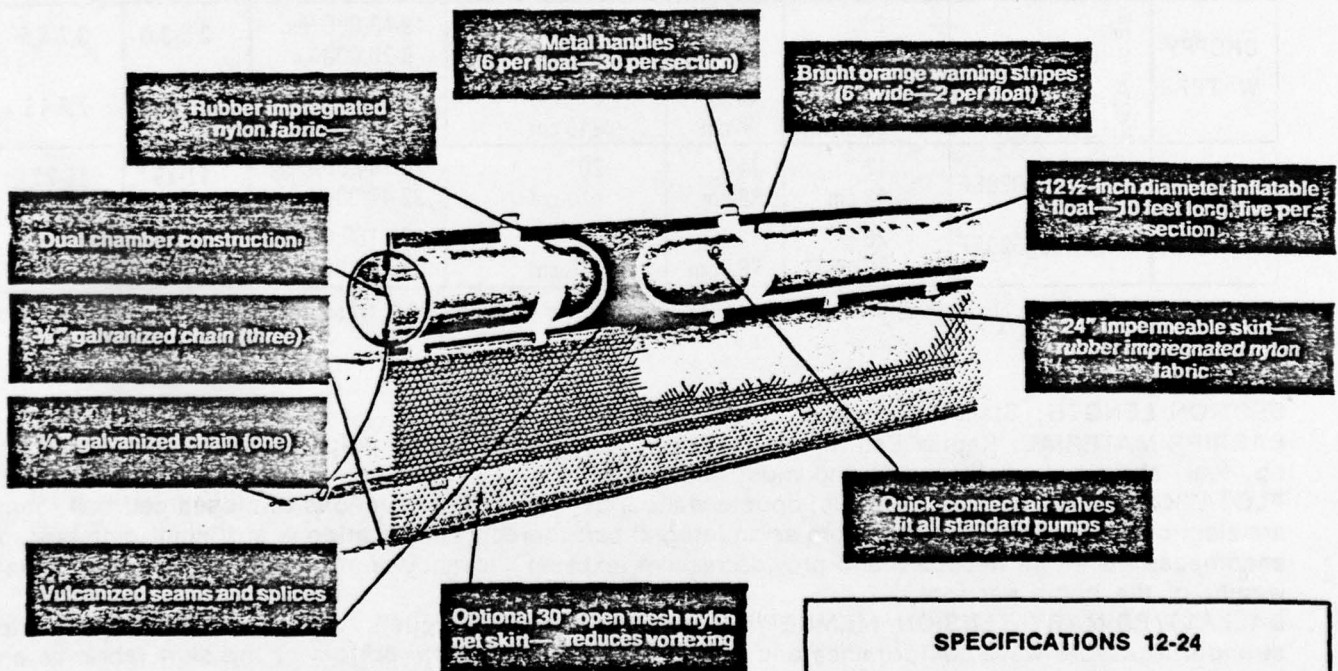

SPECIFICATIONS 12-24

Freeboard 12"
Draft	... 24" impermeable skirt; 30" open mesh skirt
Individual float length 10'
Overall section boom length 55'
Weight per foot 10 lbs.
Float size inflated 12½" dia.
Handles 6 per float segment

THIS PAGE IS BEST QUALITY REPRODUCIBLE
FROM COPY FURNISHED TO DDC

GOODYEAR AEROSPACE CORPORATION
ENGINEERED FABRICS DIVISION
ROCKMART, GEORGIA 30153
404-684-7855 H-33



"Standard" Model SeaCurtain^{T.M.} Booms

DATA SHEET

"Standard" SeaCurtain* Model – Boom Selection Chart							
SERVICE	MODEL NUMBER	NOMINAL FREEBOARD	NOMINAL DRAFT	LENGTH HINGE SECTION	GROSS TENSILE STRENGTH *	WEIGHT	
						=/ft	kg/m
CALM WATER	BHD5808FF	4" 10 cm	9" 23 cm	8' 240 cm	12,000 lbs 5,400 kg	1.0	1,5
	BHD61208FF	5" 13 cm	13" 33 cm	8' 240 cm	16,000 lbs 7,300 kg	1.2	1,8
CHOPPY WATER	A or BHD81208FF	7" 18 cm	13" 33 cm	8' 240 cm	19-43,000 lbs. 9-20,000 kg	2.5-3.0	3,7-4,5
	A or BHD141608FF	12" 30 cm	18" 46 cm	8' 240 cm	33-69,000 lbs 15-31,000 kg	5.1-8.8	7,6-13
OCEAN	AHDZ203020FF	17" 43 cm	34" 86 cm	20' 610 cm	70-104,000 lbs. 32-47,000 kg	11-18	16-27
	AHDZ303620FF	26" 66 cm	42" 107 cm	20' 610 cm	128-169,000 lbs. 58-77,000 kg	14-19	20-28

Note: "A" models include auxiliary tension cables. *A safety factor of 4:1 to 6:1 is recommended for use with these data.

SECTION LENGTH: Standard lengths are 50', 100' and 50 meters.

BARRIER MATERIAL: Keptex[®] Saturn yellow, heavy duty, plastic coated polyester fabric is resistant to rip, tear, abrasion, weather, oils and most chemicals.

FLOTATION: Eight foot long, flexible, double walled, cylindrical float sections of closed cell ball foam are electronically sealed into the boom as an integral part thereof. The flotation is sufficient diameter to encompass the entire freeboard and provide reserve (excess) buoyancy of more than 10 times the total weight of the boom per foot.

BALLAST/PRIMARY TENSION MEMBER: Galvanized chain (or equal), with sufficient weight and strength to assure wave conformance and survival, is sealed into the bottom of the skirt fabric as an integral part thereof. The chain is attached to the Quikconnect end connectors in such a manner as to maintain bottom tension and adequate draft without eccentric loading.

SECONDARY TENSION MEMBER (if required): A galvanized wire rope, polyester webbing strap or similar auxiliary tension member can be attached immediately below float line on each side of the skirt for the entire length of the boom with corrosion resistant fasteners and reinforced skirt construction. This enables the boom to handle higher loads with part of the skirt always in compression and without greatly affecting performance.

CLEANING: SeaCurtain[®] booms may be cleaned with KepKleen[®] 99 or mild detergent and warm water.

REPAIRS: Repair kits are available for very easy repairs of any component, if required.

STORAGE: Standard SeaCurtain[®] booms may be folded at each float section hinge point (usually 8') or may be wound on a reel for more efficient deployment and recovery.

OPTIONS: Standard SeaCurtain[®] booms offer unlimited options including variations in float diameter, skirt length, ballast and materials as well as "fast current", "high load" and others. See our flyer on "OPTIONS FOR SPECIAL APPLICATIONS" or contact the factory for further information and quotations.

*TRADE MARK

Offshore Devices, Inc.
Summit Industrial Park, Bldg. 43
Peabody, Massachusetts 01960

Telephone: (617) 581-6404

OFFSHORE OIL CONTAINMENT BARRIER

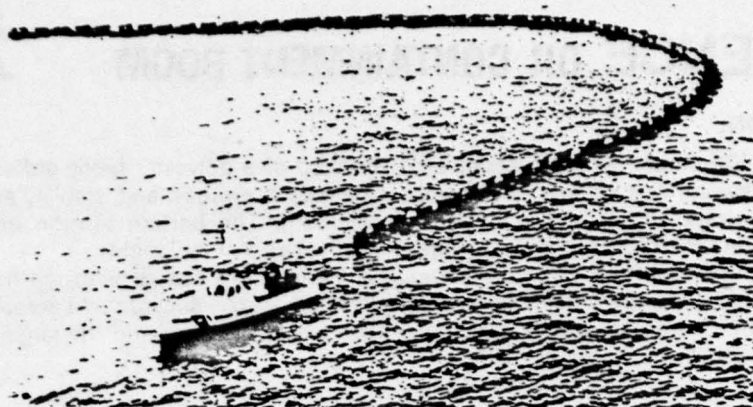

A high seas oil containment boom. It utilizes a combination of rigid panels and flexible curtain sections. The barrier incorporates both rigid flotation panels and inflatable floats which are perpendicular to the boom providing outrigger stability. It is designed to be functional in five foot seas and twenty knot winds.

HOW DEPLOYED

The boom is normally deployed in a "U" configuration. It is transported in a floatable container which may be lowered into the water by a crane at dockside or by a work boat. The end of the container will then be released and opened. One tension line extension is then accessible. This will be made fast to a vessel or dock. A work boat then attaches to the opposite end of the container and slowly moves away. The boom will thus be extracted from the container and the inflatables will automatically inflate as each leaves the container.

TOWING SPEED

3 1/2 knots in U shape. 5 knots streaming.

SWEEPING SPEED

The boom will remain functional at speeds up to 1.5 knots. However, all oil slicks, restrained by a barrier against a current, will undergo entrainment of some oil into the water flowing beneath the barrier in current speeds greater than 1 knot.

OPERATION SPECIFICATIONS

BOOM LENGTH

(612 feet) 187m. units. However, any length of 1.83m. units are available. Barrier units may be joined to maximum total length of 917m.

DRAFT

(27") 69cm.

FREEBOARD

(21") 53cm.

TOTAL HEIGHT

(48") 122cm.

CURTAIN MATERIAL RIGID PANELS

two-ply nylon, elastomer coated.

RIGID FLOTATION INFLATABLE FLOATS INFLATION MEDIUM

Strut is galvanized steel tubing 23" x 48" (58cm x 122cm.) Skimming strut is 6061-T6 aluminum with weir opening 4" x 22" (10cm x 51cm). Ethafoam panels (within steel panel).

OVERALL WEIGHT STOWAGE VOLUME BALLAST

Cylindrical 13" dia. x 48" (33cm dia. x 122cm) long, spherical ends. CO₂ automatic at extraction (16 lbs./ft.) 25kg./m., approximately. 5' x 9' x 18' (612' boom) (1.5m. x 2.8m. x 5.5m. (187m. boom alone). 22 lb. (10kg.) steel at bottom of strut; 10 lb. (4.5kg.) lead at bottom of dynamic ballast buckets.

TENSION LINE

4" (10cm.) circumference, double braid polyester.

REPAIRABILITY

Repair kits available.

COLOR

International Orange curtain material.

CLEANING

Industrial detergents and water

CONTAINER SIZE AND WEIGHT (LOADED)

20' x 8' x 8' for 612' section - 15,400 lbs.
(6m. x 2.44m. x 2.44m. for 187m. section - 7000kg.)

PERFORMANCE CAPABILITIES:

CURRENTS

Up to 1.5 knots. However, all oil slicks restrained by a barrier against a current will undergo entrainment of some oil into the water flowing beneath the barrier in current speeds greater than 1 knot.

TEMPERATURES

Compatible with all ocean temperatures.

STABILITY

Excellent.

WIND

Up to 20 knots.

WAVE HEIGHT

Typically 5' (2m.) in long waves, good performance at much higher waves is obtained.

CONFORMANCE TO MILITARY SPECIFICATIONS

Designed for and accepted by the U.S. Coast Guard

SEA FENCE OIL CONTAINMENT BOOM



CONSTRUCTION:

The SEA FENCE oil containment boom is constructed of a polyester fabric stiffened by flexible spring steel battens, to minimize splash-over. Excellent buoyancy and stability are provided by floats cut from solid blocks of flexible closed-cell foam. The bottom tension member is constructed of parallel Kevlar fibers which give high strength at a very low weight.

The flotation units, battens and bottom tension member are coated with urethane elastomer, which gives the SEA FENCE outstanding resistance to oil, water, sunlight and abrasion. The snag-free design, with its smooth seamless exterior, allows easy cleaning and the large integrally cast handles provide a sure grip for deployment.

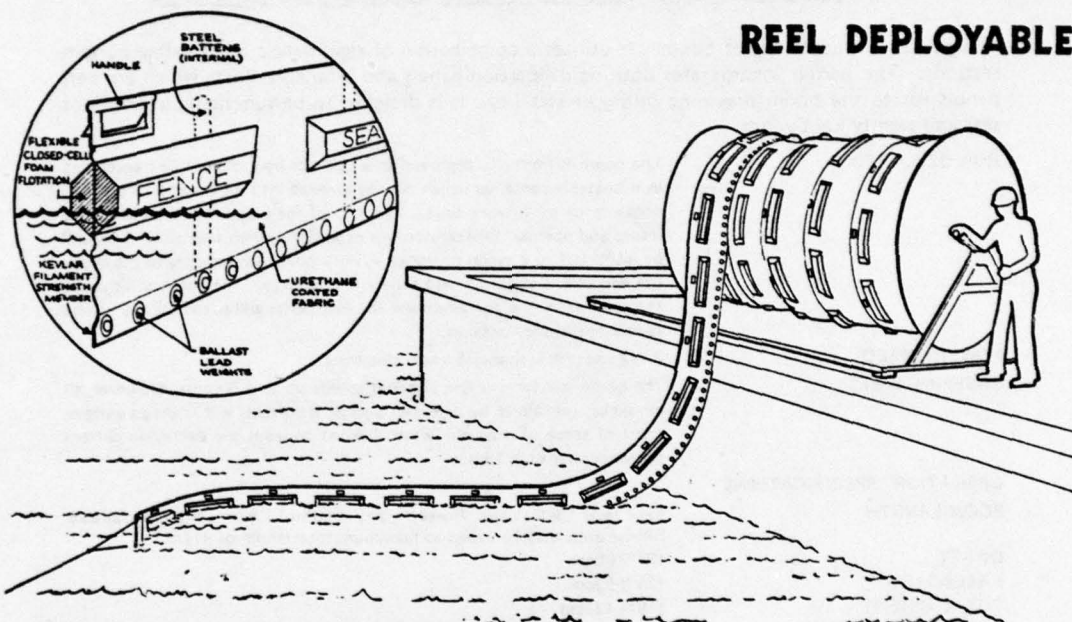

REEL DEPLOYABLE

SPECIFICATIONS	Inner Harbor Boom		Outer Harbor Boom	
	U.S. Units	Metric Units	U.S. Units	Metric Units
Height (overall)	17½ in	445 mm	28 in	710 mm
Freeboard	7½ in	190 mm	12 in	305 mm
Draft	10 in	255 mm	16 in	405 mm
Weight per Foot	2.6 lb/ft	3.9 kg/m	4.0 lb/ft	6.0 kg/m
Buoyancy per Foot	7.5 lb/ft	11.2 kg/m	12.7 lb/ft	19 kg/m
Handle Spacing	66 in	1.68 m	47 in	1.19 m
Storage Capacity of Reel (8 ft O.D. x 10 ft long)	1000 linear ft	305 m	750 linear ft	230 m
Tensile Strength (ult.)	10,000 lb	4540 kg	15,000 lb	6810 kg

Section Length: 50 ft. Colors: orange or black

Ruggedness, durability, easy cleaning and simple deployment are key features of the SEA FENCE oil containment boom. SEA FENCE combines the light weight and ease of handling required for quick response with the toughness and stability of a permanent type of boom.

Originally designed by Seaward International for the U.S. Navy, the SEA FENCE is bottom-tensioned with internal Kevlar fibers, providing full stability in currents of two knots and greater.

Rapid deployment is made easy by the SEA FENCE's ability to be stored on, and deployed from, a reel. Up to 1,000 feet of the boom can be stored on a single reel. Boom handling is facilitated by the convenient and comfortable handles built into the boom.

VIKOMA SEAPACK

SEAPACK is based on a 23 ft GRP hull and contains 1600 ft of SEABOOM. The latter is a three tube fabrication in a special Butaclor-coated nylon fabric which has a high tear strength and may be readily repaired by unskilled personnel if damaged in service. The three tube configuration gives SEABOOM effective draught and freeboard even under severe sea conditions, makes it extremely flexible and manoeuvrable and gives it good wave-following characteristics. The inflation cuff prevents the boom twisting during the laying operation and aids recovery after use.

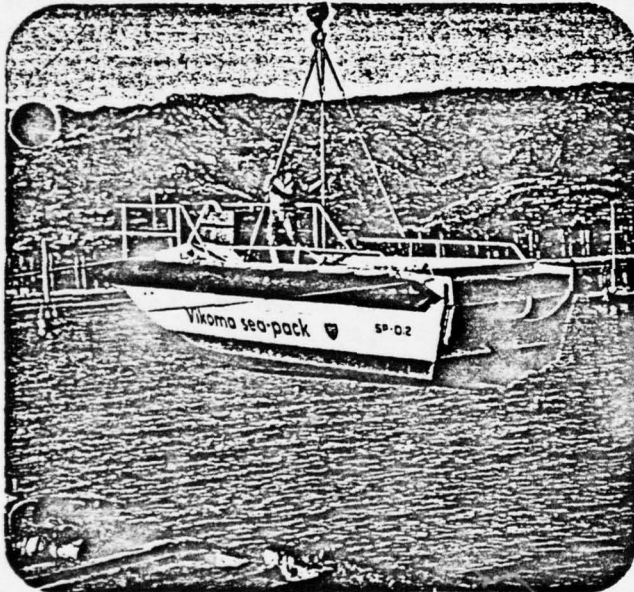

SEAPACK being lowered into water by its own lifting strrops.

SEAPACK may be launched from a slipway or lowered into the water from a crane. Thereafter its diesel engine is started and it is towed to the operation site. Fuel consumption is small and long tows will not restrict subsequent operations. On arrival at the scene of an accident, boom deployment is initiated by launching a drogue (sea anchor) which is already attached to the SEAPACK hull's stern. SEAPACK is then towed away at 3-4 knots and its 1600 ft of boom lays and inflates automatically in only 15 minutes. Once this operation is complete, the boom compartments will remain inflated even if the boom is subsequently damaged.

One end of the boom is connected within the SEAPACK hull to a diesel-driven fan and ducted propeller water pump which simultaneously fill the air and water tubes. Compressed air cylinders are included for inflating the flotation cuff. The hull has a towing ring and large inflatable fender. No crew is required and no manual attention to SEAPACK is necessary after launching until the boom has to be recovered after use.

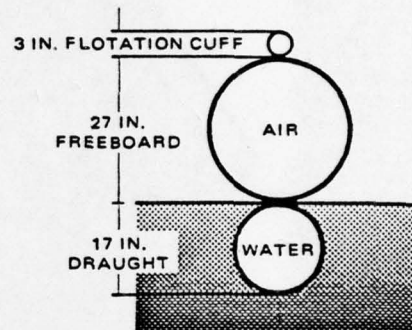

Boom structure

SEAPACK is easily transportable. Over reasonable distances it may be towed on its own trailer. Over long distances, where speed is important, it should be carried on a lorry or truck, on board ship, or in a suitable transport aircraft such as a Hercules freighter.

SEAPACK being re-packed after use.



Whittaker Expandi-OIL BOOM

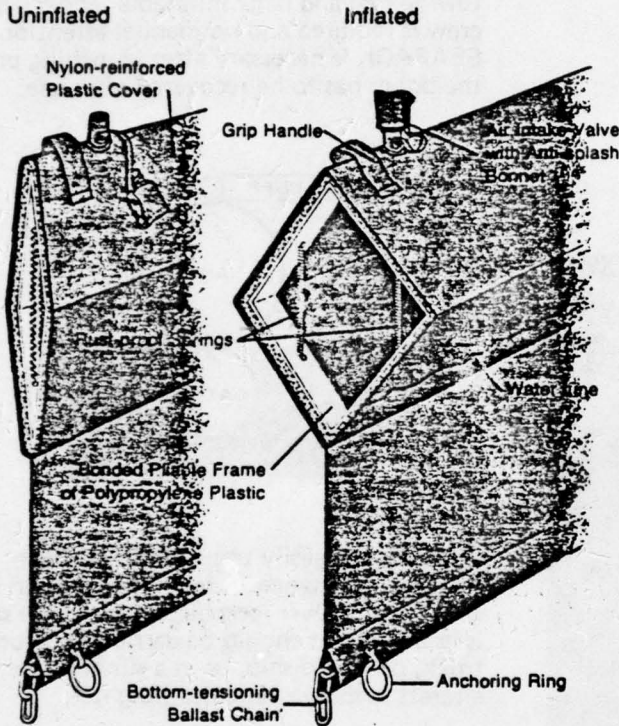

THIS PAGE IS BEST QUALITY FRAGRANCE FROM COPY FURNISHED TO DDC

HOW IT WORKS

The boom is self-inflating and expands by itself the moment it is released. Made of tough, durable material, it operates in temperature extremes from +74°C. (+165°F.) to subfreezing exposure and is oil-proof and mold-resistant.

The boom has internal bonded pliable frames which are pre-sprung with rust-proof springs. Each 25-meter boom contains 18 sections, with airtight spaces between sections. A bottom-tensioning chain is used to serve as ballast. The boom also incorporates anchoring rings and grip handles on 8-meter intervals.

The boom comes folded and tied in 25-meter segments. To cover large areas fast, multiple elements can be pre-connected and packed for transport to an oil-threatened area.

Segments are joined by inserting the skirt end of one into the metal clip end of another and sliding the two together, pulling a ring and a handle. The ballast chain is joined and locked with a simple slot key.

SPECIFICATIONS

	Harbor Boom Model No. 3000		Sea Boom Model No. 4300	
	Metric	English	Metric	English
Breaking strength of ballast chain (approx.)	2590 kgf	5700 lbf.	7500 kgf	16,500 lbf
Dimensions	25 meters long in a package 900mm x 700mm x 380mm.	82 feet long in a package 35.42" x 27.56" x 14.96".	15.2 meters long in a package 850mm x 1050mm x 300mm.	50 feet long in a package 33.46" x 41.34" x 11.81".
Volume of boom element	0.25m ³	8.8 cu. ft.	0.27m ³	9.5 cu. ft.
Buoyancy	53 kg/linear meter	36 lbs./linear foot	120 kg/linear meter	83 lbs./linear foot
Weight per section	58 kg	127.9 lbs.	80 kg	176.4 lbs.
Boom resistance in tearing	300 kp/5 cm	670 lbs./2" width	410 kp/5 cm	915 lbs./2" width
Boom material weight	600 gm/m ²	.123 lbs./ft. ² = $\frac{18}{100} \frac{oz}{yd}^2$	800 gm/m ²	.164 lbs./ft. ²
Freeboard	280mm	11.02"	450mm	18.02"
Draft	470mm	18.50"	650mm	25.50"
Accessories	Patch kits of adhesive and fabric; towing adaptors for Model 3000 750mm (30") Harbor Boom and for Model 4300 1100mm (43") Sea Boom; and magnet adaptors.			

WSP SPRAY BOOM SYSTEM DISPERSANT APPLICATOR

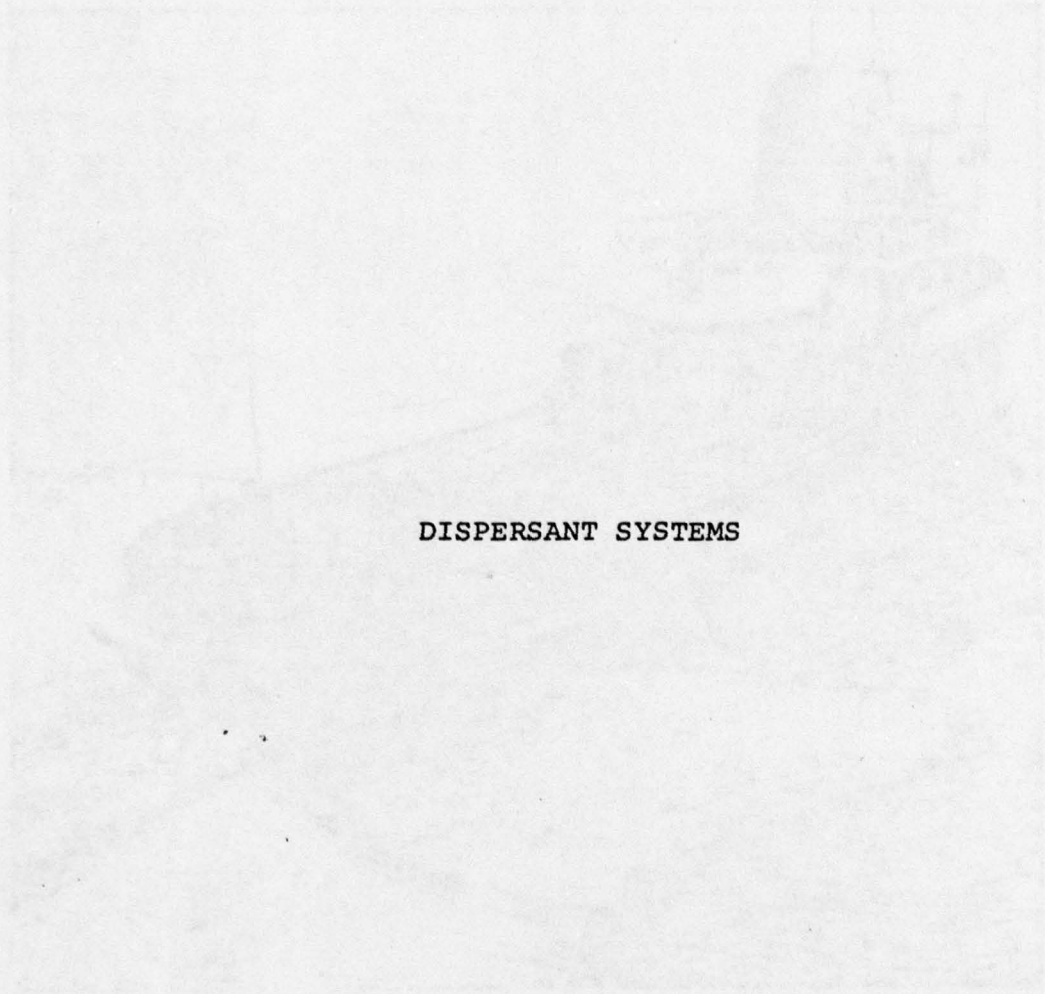

DISPERSANT SYSTEMS

WSP SPRAY BOOM SYSTEM

DESCRIPTION

The WSP Spray Boom System is a complete, self-contained, and highly efficient dispersant application system. It is designed for use in a wide variety of applications, including the application of herbicides, insecticides, and other agricultural chemicals. The system consists of a pump, a spray boom, and a vertical support structure. The pump is mounted on the support structure and is connected to the spray boom. The spray boom is a long, horizontal tube with a series of nozzles spaced along its length. The support structure is a vertical frame that holds the pump and the spray boom in place. The system is easy to operate and maintain, and it provides a uniform and thorough application of dispersants.

The WSP Spray Boom System is a highly efficient and reliable dispersant application system. It is designed for use in a wide variety of applications, including the application of herbicides, insecticides, and other agricultural chemicals. The system consists of a pump, a spray boom, and a vertical support structure. The pump is mounted on the support structure and is connected to the spray boom. The spray boom is a long, horizontal tube with a series of nozzles spaced along its length. The support structure is a vertical frame that holds the pump and the spray boom in place. The system is easy to operate and maintain, and it provides a uniform and thorough application of dispersants.

The WSP Spray Boom System is a highly efficient and reliable dispersant application system. It is designed for use in a wide variety of applications, including the application of herbicides, insecticides, and other agricultural chemicals. The system consists of a pump, a spray boom, and a vertical support structure. The pump is mounted on the support structure and is connected to the spray boom. The spray boom is a long, horizontal tube with a series of nozzles spaced along its length. The support structure is a vertical frame that holds the pump and the spray boom in place. The system is easy to operate and maintain, and it provides a uniform and thorough application of dispersants.

WARREN SPRING DISPERSANT SYSTEM

SEAWARD INTERNATIONAL, INC.

WSL SPRAY BOOM SYSTEM DISPERSANT APPLICATOR

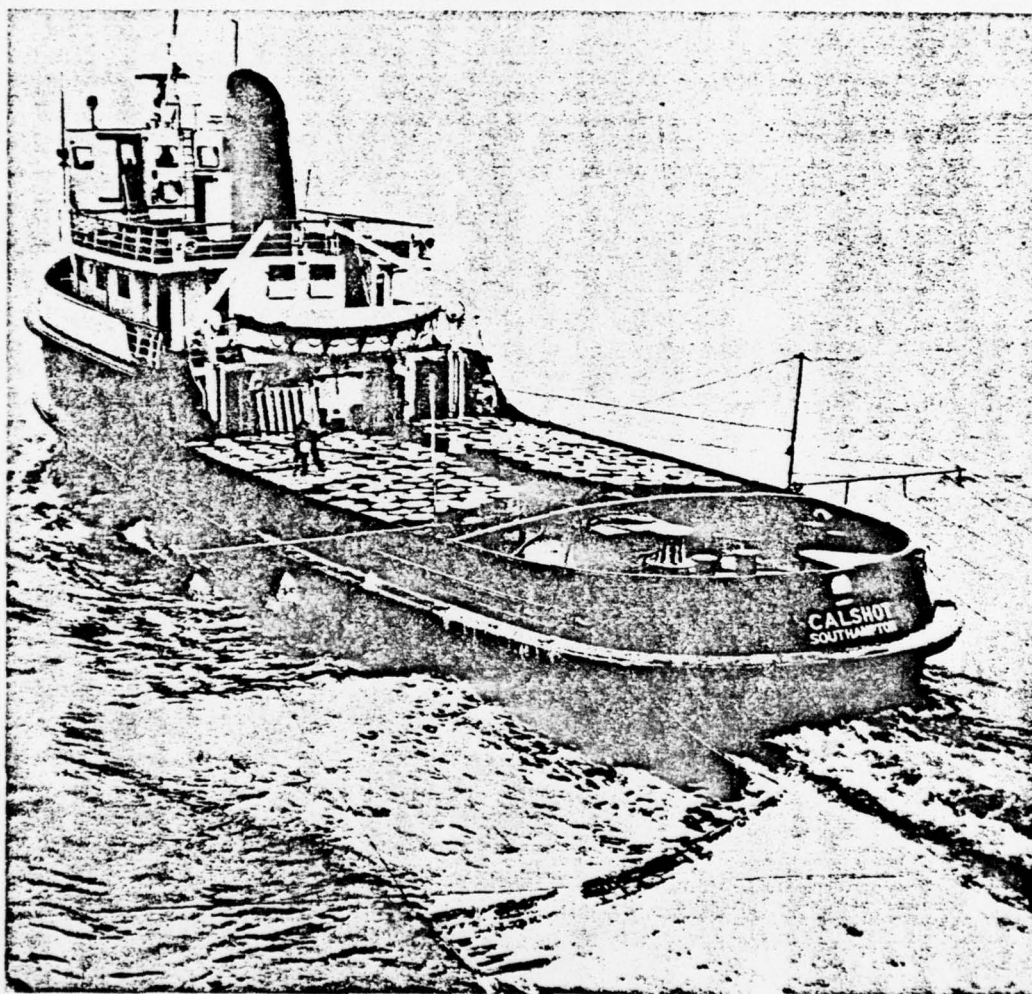

DESCRIPTION

The WSL SPRAY BOOM SYSTEM, developed by the Warren Spring Laboratory of the British Department of Industry, is designed to apply dispersant to floating oil and to agitate the treated oil to speed the dispersion of the slick. The equipment is designed for installation on vessels of opportunity, such as tugs or fishing boats. It can be rigged without welding or fitting and without skilled labor.

The dispersant is applied uniformly over a wide area by means of spray booms rigged outboard from either side of the vessel. A diesel driven pump transfers the dispersant material, at a rate of 24 gpm, from storage tanks or drums to the multiple spray nozzles on each boom. "Surface-breaker" boards towed behind the spray booms agitate the treated oil, forcibly mixing it with the upper few inches of sea water, breaking the oil slick up into droplets.

A smaller version, designed for use on small boats, is shown on the reverse. This equipment is particularly suited for inshore, shallow water use.

CLEAN ATLANTIC DISPERSANT SYSTEM

A chemical dispersant spraying system for use on sea-going work boats has been developed. Using two spray booms, the system can spray a path up to 18.3 m (60 ft) wide at a speed of 8 knots, thus covering approximately 0.27 km^2 (67 acres) per hour. The design is based on the use of "self-mix surfactant." It requires little mixing energy for effective dispersion of the oil slick. Three of these systems have been completed for Clean Atlantic Associates, an oil spill clean-up cooperative.

The system is made up of an apparatus for deploying and supporting two 6.1 m (30 ft) spray booms, a 33.6 kw (45 hp) pump skid for pumping a mixture of seawater and dispersant, and Marine Portable 1892.5 litre (500 gal) tankage for storing the dispersant.

The spray apparatus is designed to be attached to the bow of the boat. This allows the boom to spray the mixture of seawater and dispersant ahead of the bow wake. Subsequent mixing energy is provided by the bow wake. When not using a self-mix dispersant, additional mixing energy can be provided by breaker boards, however, these are not included in this system.

Seawater is drawn from an overboard suction line, proportioned with the chemical dispersant at a typical ratio of 33 to 1, and pumped at high pressure, 0.62 to 0.69 N/m^2 (90 to 100 psi), through fan-type nozzles.

The entire system is readily adaptable to various sizes and shapes of vessels, and operates independently of the vessel to which it is mounted.

Reference: Allen, T.E., "Apparatus for Application of Chemical Dispersants in Open Sea," ASTM Symposium on Chemical Dispersants for the Control of Oil Spills, Williamsburg, VA., Aug. 1977.

NEW FLEXIBLE DISPENSER SYSTEM

A chemical dispensing system for use on sea-going work boats has been developed. Using two spray booms, the system can spray a path up to 18.2 m (60 ft) wide at a speed of 8 knots. The spray booms are approximately 0.27 m (10 in) apart. The system is based on the use of "self-mixing" nozzles. It requires little mixing energy for effective dispersion of the oil. Three of these systems have been completed for clean trials. The system is made up of an apparatus for supplying and supporting the spray booms, a 35.6 kw (48 hp) pump unit for pumping a mixture of seawater and dispersant, and various portable 189.3 liter (50 gal) tanks for storing the dispersant.

FLEXIBLE OIL RECEIVER

The spray apparatus is designed to be attached to the bow of the boat. This allows the boom to spray the mixture of seawater and dispersant ahead of the bow wave. Subsequent mixing energy is provided by the bow wave. When not using a self-mixing nozzle, additional mixing energy can be provided by diesel nozzles. However, these are not included in this system. The receiver is drawn from an overhead suction line, proportional with the chemical dispersant and typical ratio of 15 to 1, and pumped at high pressure, 0.63 to 0.84 MPa (90 to 120 psi) through fan-type nozzles.

The entire system is readily adaptable to various sizes and shapes of vessels, and operates independently of the vessel's speed.

Author: William E. Johnson for Application of Chemical Dispersants to Oil Spills, 1974, Symposium on Chemical Dispersants for the Control of Oil Spills, Washington, VA, Aug. 1973.



DRACONE BARGE

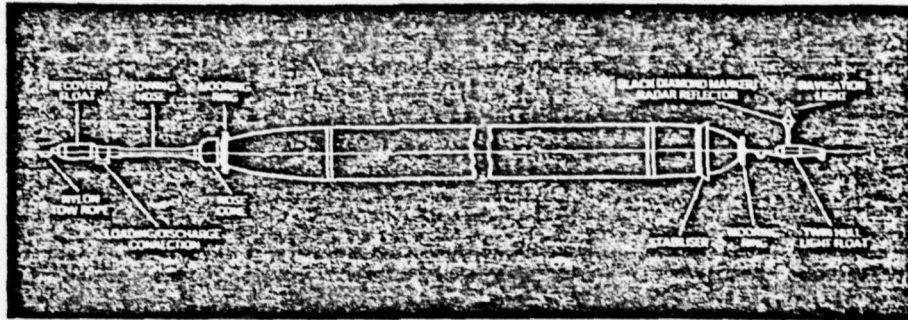

TYPE		A1	A2	D5	D10	E	F	J	L	O
100% Capacity	Cu. metres	4.6	9	23	45	100	190	367	521	1 100
100% Capacity	Imp. Gallons	1 000	2 000	5 000	10 000	22 000	42 000	81 000	114 000	242 000
100% Capacity	Litres	4 545	9 090	22 730	45 450	100 010	190 930	368 225	518 240	1 100 12
100% Capacity	U.S. Gallons	1 200	2 400	6 000	12 000	26 400	50 400	97 200	136 800	290 400
100% Capacity	Barrels	28	56	142	285	628	1 200	2 314	3 257	6 914
Length	Metres	8	14	15	31	38	50	68	67	91
Diameter	Metres	0.94	0.94	1.42	1.42	1.88	2.30	2.75	3.20	4.30
Empty Weight kg.		203	300	390	743	1 000	2 275	3 536	4 065	4 318
Draught Fully loaded in sea water Metres	Cargo S. G.									
	0.7	0.60	0.60	0.85	0.85	1.14	1.42	1.50	1.58	2.25
	0.8	0.68	0.68	0.95	0.95	1.27	1.50	1.80	1.98	2.54
	0.9	0.78	0.78	1.13	1.13	1.52	1.70	2.10	2.25	2.87
	1.0	0.90	0.90	1.32	1.32	1.70	1.95	2.50	2.60	3.70
Towing hose bore mm.		50	50	50	100	100	100	100	100	100
Drag kg. fully laden in sea water	Speed									
	4 Knots	150	157	180	189	300	481	558	1 188	2 132
	6 Knots	260	273	450	472	700	1 118	1 338	2 614	4 069
	8 Knots	396	415	960	975	1 500	2 090	2 495	4 700	—
	10 Knots	574	602	1 450	1 487	2 300	3 309	4 241	—	—

THIS PAGE IS BEST QUALITY REPRODUCTION
FROM COPY FURNISHED TO DDC