

AD-A079 753

NAVAL OCEAN RESEARCH AND DEVELOPMENT ACTIVITY NSTL S--ETC F/G 8/11
MARINE SEISMIC DISPLAY ENHANCEMENT PROGRAM. VOLUME III. USERS H--ETC(U)
JAN 78 B E ECKSTEIN, M G FAGOT

UNCLASSIFIED

NORDA-TN-15

NL

1 OF 1
AD-
A079753

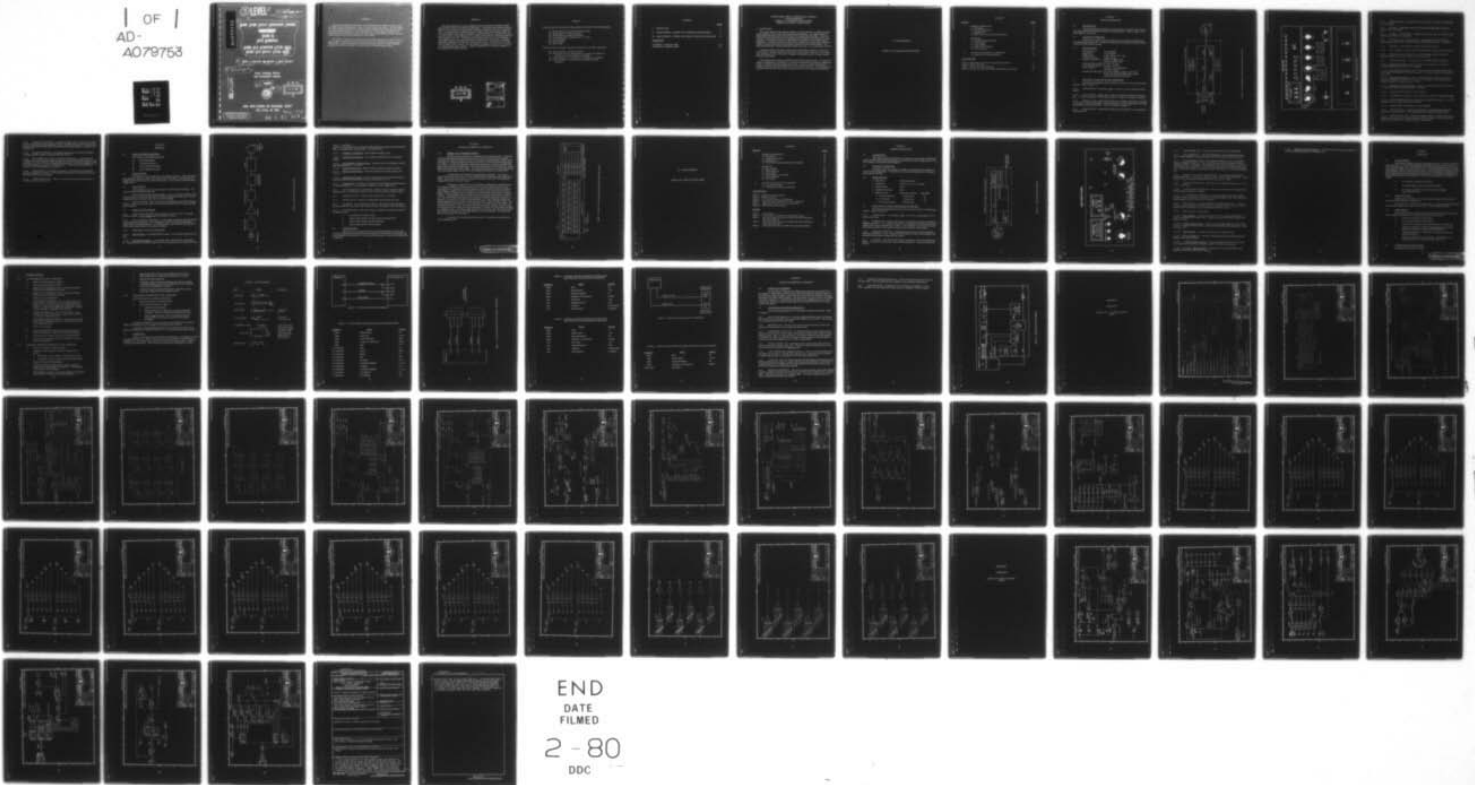

END
DATE
FILMED
2-80
DDC

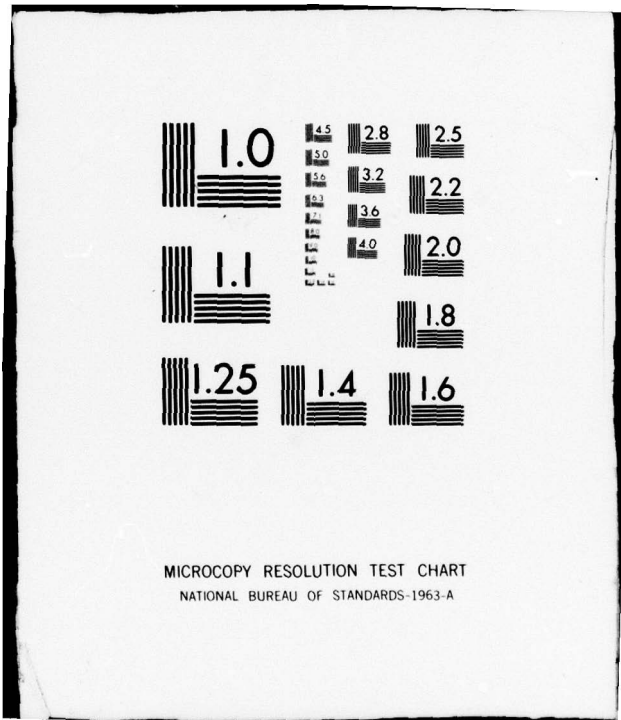

MICROCOPY RESOLUTION TEST CHART
NATIONAL BUREAU OF STANDARDS-1963-A

FOREWORD

This report describes the operation of the instrumentation developed to digitally record and display seismic profiling data. There are two sections to this report. The first section is a users handbook which describes proper operation techniques for the Seismic Data Acquisition System (SDAS) hardware. The second section is a users handbook describing the proper operation techniques for the Seismic Data Display System (SDDS) hardware. Included in this report are the circuit schematics for each system.

This report is Volume III of the Marine Seismic Display Enhancement Program Final Report. Volume I presents a summary of project results with examples of processed seismic profiling data. Volume II describes the processing software programs and the operating procedure for their use on either the Univac 1108 or CDC 6600 computer system.

ABSTRACT

This report describes in a users handbook format the operation of hardware systems used to acquire and play back seismic profiling data. The Seismic Data Acquisition System digitizes 1 to 16 channels of analog seismic information and records this data on magnetic tape. This digital data has a maximum dynamic range of 72 dB and maximum sample rate of 10 KHz divided by the number of channels. Record lengths up to 15 seconds with a maximum record delay, before digitizing, of 15 seconds may be selected. Maximum signal level for the system is ± 10 volts. The Seismic Data Display System converts a 36 dB dynamic range digital signal to an analog signal having a maximum level of ± 10 volts. The digital information displayed will contain 1977 data points per record. The system has the capability to display seismic data on a line scan intensity modulated recorder, an x-y recorder, or a high speed fiber optic recorder. Included as appendices are schematic diagrams of the acquisition and display hardware.

DDC
RECEIVED
JAN 23 1980
B

ACCESSION for	
NTIS	White Section <input checked="" type="checkbox"/>
DOC	Buff Section <input type="checkbox"/>
UNANNOUNCED	<input type="checkbox"/>
JUSTIFICATION	
BY	
DISTRIBUTION/AVAILABILITY CODES	
Dist.	AVAIL. and/or SPECIAL
A	

PREFACE

These systems were developed and documented by the efforts of the following people:

Mr. Charles Stockton (currently with NAVOCEANO)
Mr. Thomas Mero (currently with NOAA)
Mr. Phillip Libraro (currently with NOAA)
Mr. Frank Stookesbury (currently with U. S. Army)
Mr. Frank Carnaggio
Mr. Bruce Eckstein
Mr. Martin Fagot

The editors wish to recognize the specific contribution of the above individuals.

Mr. Charles Stockton - Design of the SDAS
Mr. Thomas Mero and Mr. Phillip Libraro - Design of the SDDS and
and preparation of the SDAS Users Handbook
Mr. Frank Stookesberry - Preparation of the SDDS Users Handbook
Mr. Frank Carnaggio - System checkout and updating systems
schematics

CONTENTS

	<u>PAGE</u>
I. INTRODUCTION	1
II. USERS HANDBOOK - SEISMIC DATA ACQUISITION SYSTEM (SDAS)	3
III. USERS HANDBOOK - SEISMIC DATA DISPLAY DISPLAY SYSTEM (SDDS)	17
<u>APPENDICES:</u>	
APPENDIX A: Schematics SDAS	37
APPENDIX B: Schematics SDDS	91

MARINE SEISMIC DISPLAY ENHANCEMENT PROGRAM
USERS HANDBOOKS
SEISMIC DATA ACQUISITION SYSTEM (SDAS)
SEISMIC DATA DISPLAY SYSTEM (SDDS)

I. INTRODUCTION

This report consists of two separate sections. The first section is a handbook describing the operation of the Seismic Data Acquisition System (SDAS). The second section is a handbook describing the operation of the Seismic Data Display System (SDDS). These two instruments were developed to provide geophysical instrumentation with sufficient accuracy, resolution, and frequency response to allow detailed investigation of sub-bottom acoustic propagation. The SDAS acquires the information in a digital format which allows application of filter and deconvolution processing software through a central computer facility. The SDDS allows playback of the processed data through a line scan, x-y, or fiber optic recorder.

The SDAS provides a maximum sample rate of 10 KHz with a maximum of 15-second record lengths. The SDAS also has a maximum of 72 dB dynamic range and a ± 10 volt maximum signal input voltage. The system is capable of digitizing from one to sixteen separate channels of information.

The SDDS provides a display of digital data having 36 dB dynamic range. The system is capable of displaying this information in an intensity modulated line scan format, wiggle trace format, or intensity modulated wiggle trace format. A half wave filled wiggle format is available through an experimental interface for the fiber optic recorder. An operational configuration of this interface had not been completed at the time this handbook was published.

II. USERS HANDBOOK

SEISMIC DATA ACQUISITION SYSTEM (SDAS)

CONTENTS

<u>SECTION</u>		<u>PAGE</u>
1	GENERAL INFORMATION	5
	1.1 Introduction	5
	1.2 Concept of Operation	5
	1.3 Specifications	5
	1.4 SDAS Front Panel Functional Description	5
2	OPERATION	11
	2.1 Initial Powering Procedure	11
	2.2 Analog Inputs	11
	2.3 Tape Loading	11
	2.4 Basic Control Settings	11
	2.5 Powering Down	13
3	CONCEPT AND THEORY OF OPERATION	15
	3.1 Seismic Data Acquisition System	15

ILLUSTRATIONS:

Figure 1: Block Diagram of Seismic Data Acquisition System	6
Figure 2: SDAS Front Panel	7
Figure 3: Seismic Data Recording Setup	12
Figure 4: Seismic Data Acquisition System (SDAS) Data Tape Format	16

SECTION 1
GENERAL INFORMATION

1.1 INTRODUCTION

This section provides information on the operation of the Seismic Data Acquisition System (SDAS), which includes elementary setup procedures. Refer to Figure 1 for a block diagram of the system.

1.2 CONCEPT OF OPERATION

Seismic Data Acquisition System (SDAS) provides a facility for digitizing and recording marine seismic data. The data is formatted for processing on either the UNIVAC 1108 or CDC 6600 computer system.

1.3 SPECIFICATIONS

ANALOG INPUT:	1 to 16 channels
MAX INPUT:	±10 volts peak
RESOLUTION:	11 bit + sign or 5 bit + sign
DYNAMIC RANGE:	72 dB or 36 dB
SAMPLE FREQUENCY:	200 Hz to 10 KHz (12 bit) 200 Hz to 20 KHz (6 bit)
DATA RECORD LENGTH:	0.5 sec. to 15 sec.
DATA RECORD DELAY:	0.4 msec. to 15 sec.
TAPE FORMAT:	UNIVAC or CDC compatible 7 channel, 556 BPI
HEADER INFORMATION:	Day, time, sample frequency, data record length, and data record delay, plus 15 BCD switches for additional annotation

1.4 SDAS FRONT PANEL FUNCTIONAL DESCRIPTION

The following paragraphs briefly describe the function of each of the front panel controls. (Refer to Figure 2.)

- 1.4.1 **POWER SWITCH.** Two position toggle, ON and OFF, powers SDAS logic mainframes.
- 1.4.2 **FILE COUNTER.** Digital readout counter that counts the number of records on tape. A record corresponds to a shot-return sequence. (Number not recorded on header.)
- 1.4.3 **DIGITAL CLOCK.** Digital readout of day, hour, minute, and second is recorded for each shot as header information. The clock provides a 100 KHz signal used by the SDAS as the master system internal clock. (Clock is not shown in Figure 2.)
- 1.4.4 **ANALOG INPUTS.** Sixteen BNC connectors are provided for 1 to 16 channels of analog input data.

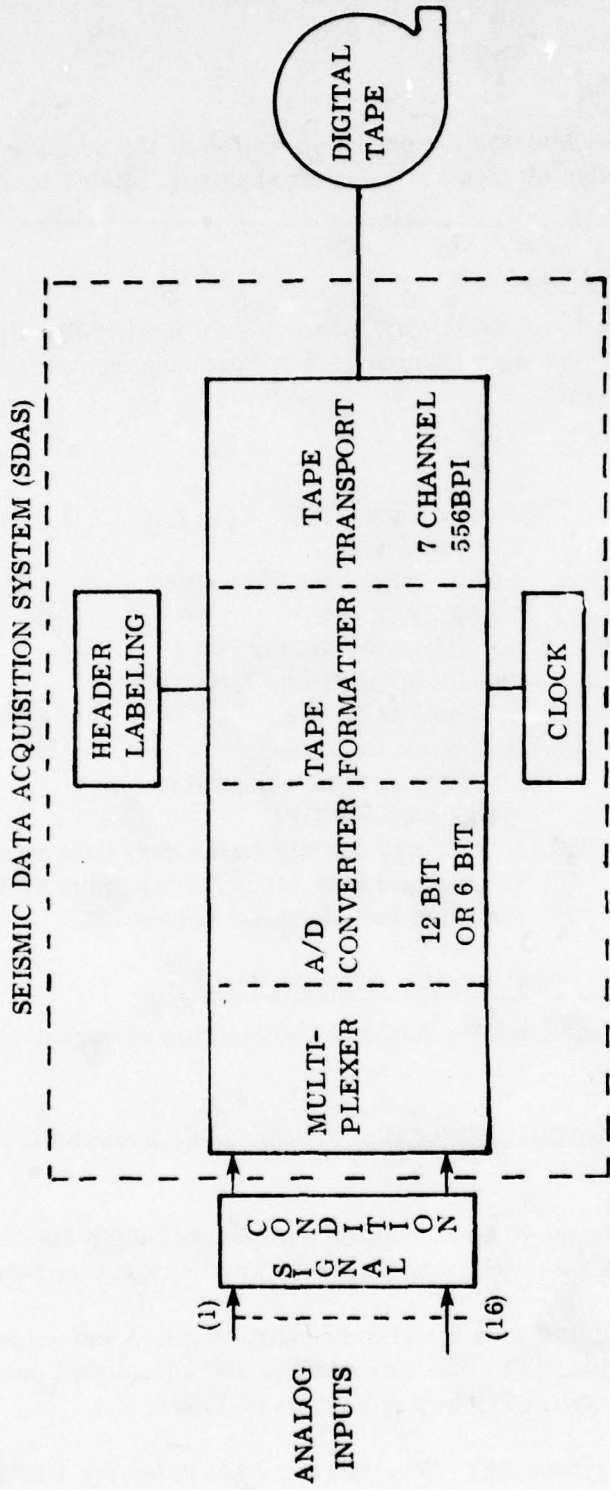

Figure 1. Block Diagram of Seismic Data Acquisition System.

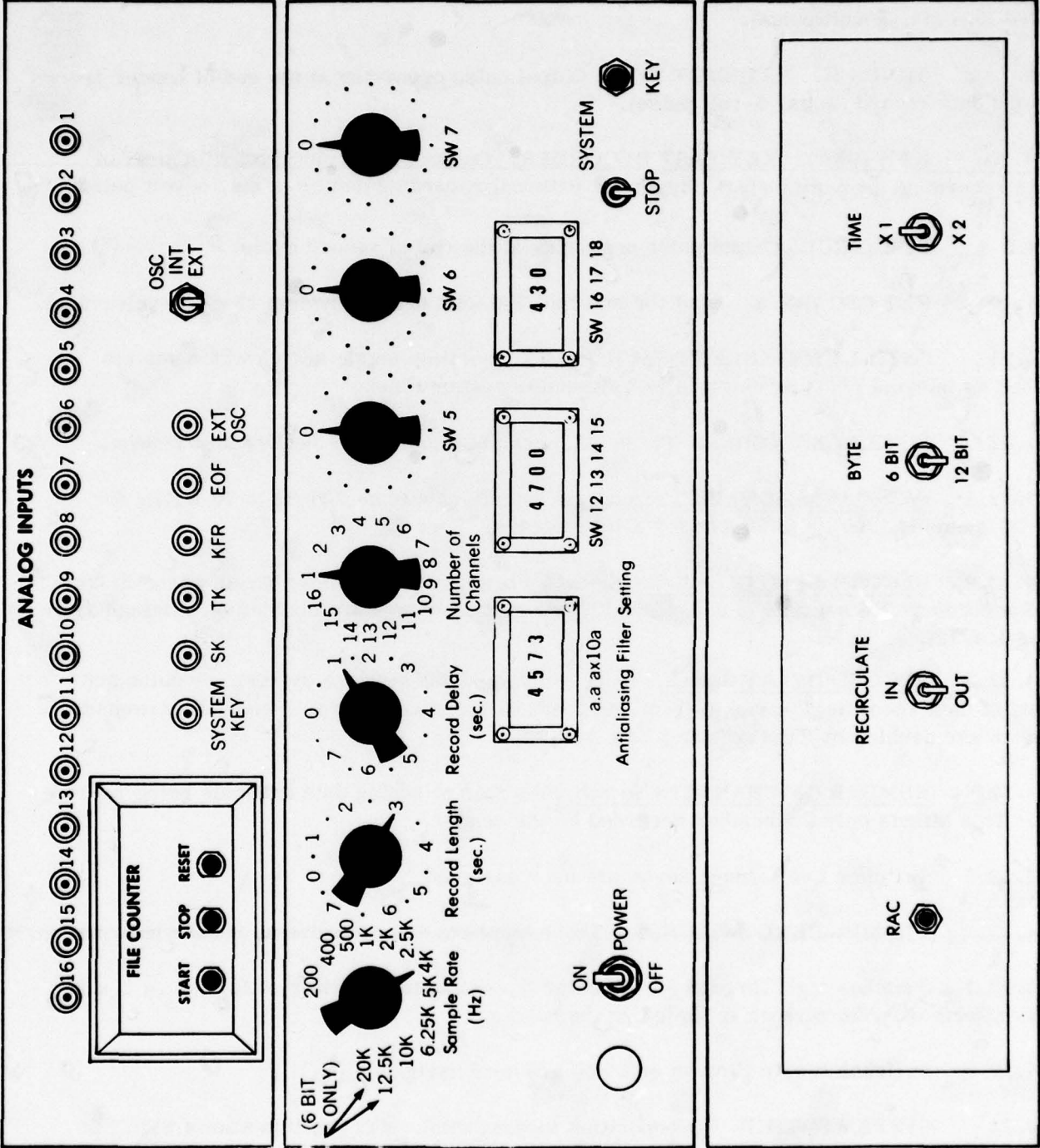

Figure 2. SDAS Front Panel

- 1.4.5 SYSTEM KEY (BNC). External system key input pulse (triggers on leading edge of a 5-volt pulse).
- 1.4.6 SK (BNC). Output pulse occurring coincident with leading edge of system key pulse (0.4 ms, 5-volt pulse).
- 1.4.7 TK (BNC). TRANSMIT KEY. Output pulse occurring at the end of header record before data record (2 ms, 5-volt pulse).
- 1.4.8 KFR (BNC). KEY FAST RECORDER. Output pulse coincident with start of data recording, providing start trigger for external recording device (2 ms, 5-volt pulse).
- 1.4.9 EOF (BNC). Output pulse occurring at the end of record cycle.
- 1.4.10 EXT OSC (BNC). Input for external 100 KHz master system clock (5-volt pulse).
- 1.4.11 OSCILLATOR SELECT SWITCH. Two-position toggle switch which selects either an internal (INT) or external (EXT) master system clock.
- 1.4.12 ROTARY SWITCHES. These numbers are recorded as header information.
- 1.4.12.1 SAMPLE RATE Switch. Selects a sample rate from 200 Hz to 10.0 KHz for 12-bit samples, 200 Hz to 20 KHz for 6-bit samples.
- 1.4.12.2 RECORD LENGTH Switch. Selects a digitized data record length variable from 0.5 seconds to 7.5 seconds in 0.5-second increments. Values are doubled by Timing Switch (see 1.4.19).
- 1.4.12.3 RECORD DELAY Switch. Selects a time delay between system key pulse and start of data recording, variable from 0 seconds to 7.5 seconds in 0.5-second increments. Values are doubled by Timing Switch (see 1.4.19).
- 1.4.12.4 NUMBER OF CHANNELS Switch. Number of analog data channels being recorded. This affects only the number recorded on the header.
- 1.4.12.5 Switches five through seven are user assigned.
- 1.4.13 THUMBWHEEL SWITCHES. These numbers are recorded as header information.
- 1.4.13.1 Switches eight through eleven enter the anti-aliasing filter setting ($a \cdot a \times 10^{a^4}$). This affects only the number recorded on the header.
- 1.4.13.2 Switches twelve through eighteen are user assigned.
- 1.4.14 SYSTEM SWITCH. Two-position toggle switch. ON position allows SYSTEM KEY pulses to start the system. STOP position allows no external system key pulses.
- 1.4.15 SYSTEM KEY BUTTON. Momentary pushbutton switch. Internally keys the system at any time even when the SYSTEM switch is in the STOP position. (Do not press when system is in recording cycle as record contains erroneous data.)

1.4.16 DYNAMIC RANGE SWITCH. Two-position toggle switch. Must be set for either 6 bits or 12 bits dynamic range (normally 12 bits). Dynamic range must also be set on A/D converter (Miniverter System) SHORT CYCLE Switch for proper operation. (Labeled BYTE on Figure 2.)

1.4.17 RECIRCULATE SWITCH. Two-position toggle switch; IN and OUT positions. IN position initiates recorder recirculate mode (see 2.4.3.2).

1.4.18 RAC PUSHBUTTON. READ A CHARACTER pushbutton. In the READ mode (formatter unit), this pushbutton enables the operator to read the information written on tape, a character at a time. Each time the pushbutton is pressed, a 6-bit word is displayed on six LED's (mainframe row 2, card 36, energized being a "1" state and de-energized being a "0" state). For bit interpretation, see Figure 4.

1.4.19 TIMING SWITCH. In NORMAL (X1) position, RECORD DELAY and RECORD LENGTH are labeled on the panel. In the EXPAND (X2) position, the RECORD DELAY and RECORD LENGTH times are doubled.

1.4.20 PARITY ERROR LIGHT. LED is lit if a parity error occurs in the process of recording (not shown on Figure 2).

SECTION 2
OPERATION

2.1 INITIAL POWERING PROCEDURE

Turn on power in the following sequence:

- (a) SDAS system power
- (b) A/D Miniverter power
- (c) TAPE FORMATTER power
- (d) TAPE TRANSPORT power

2.2 ANALOG INPUTS

See Figure 3 for basic signal flow in recording seismic data. Assure the analog input signals are within the range of ± 10 V with a zero volt DC offset. The inputs are DC coupled to the Miniverter and a DC offset will bias data. Do not overdrive individual filters' voltage levels.

2.3 TAPE LOADING

Before loading, be sure the reel of tape has a WRITE RING on the back. The system will not record without this ring.

Load a full reel of tape on bottom spindle. Press in the center of spindle to lock the reel in place. Thread tape according to the diagram printed on the tape deck. Be sure enough tape has been wound on empty reel to assure no slipping.

Press LOAD button. Tape will advance to the Beginning of Tape (BOT) marker and halt. Ensure that the RING light is on which indicates WRITE RING is in place and tape can be recorded.

2.4 BASIC CONTROL SETTINGS

2.4.1 TAPE FORMATTER MODE Switch (DIGIDATA MODEL LC 0117). Set mode switch to RECORD. (Do not change mode while system is on line.)

2.4.2 ANALOG/DIGITAL MINIVERTER. Set the number of channels used (end channel) and the channel to be displayed. These switches are coded in octal with 00 indicating 1 channel and 10 indicating 9 channels. The sampling rate on each channel is the SAMPLING RATE switch setting divided by the number of channels.

2.4.3 SDAS FRONT PANEL AND MAINFRAME

2.4.3.1 SYSTEM Switch. Set SYSTEM Switch to STOP. An EOF mark is ready to go on tape.

2.4.3.2 RECIRCULATE Switch. At slow sample rates, (below 1 KHz), turn switch to IN. The tape recorder will stop if a parity error is encountered and try to rewrite the error

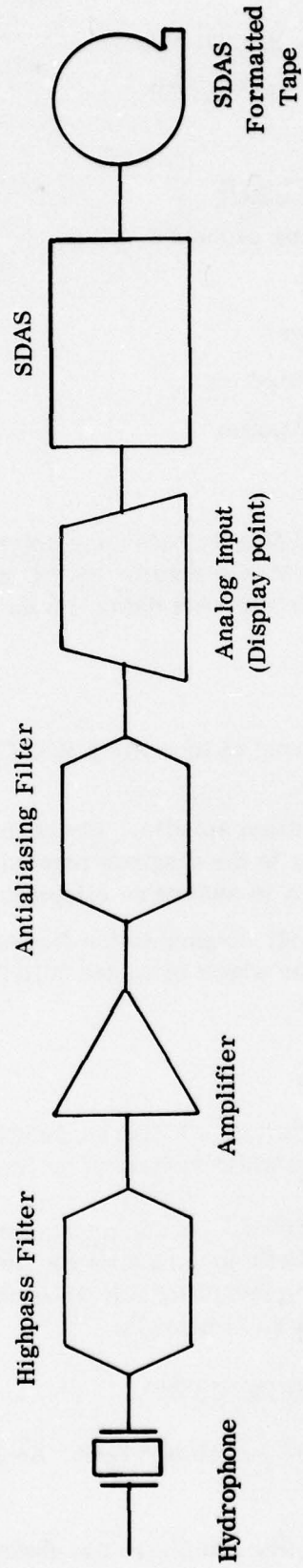

Figure 3. Seismic Data Recording Setup

2.4.3.2 (continued)
record. If the error persists, the PARITY ERROR light will energize and the system will stop. For sample rates 1 KHz and above, turn switch to OUT.

2.4.3.3 NUMBER OF CHANNELS. Set the number of channels used.

2.4.3.4 DYNAMIC RANGE Switch. Set to number of bits desired (6 or 12 bits) per sample.

2.4.3.5 ANTI_ALIASING FILTER SETTING. Place filter value in thumbwheel switches eight through eleven ($a . a a \times 10^a$).

2.4.3.6 SAMPLE RATE Switch. Select the desired sample rate (Hz) for the data.

2.4.3.7 RECORD LENGTH Switch. Select the desired record length (seconds) (see 2.4.3.9).

2.4.3.8 RECORD DELAY Switch. Select the desired time delay (seconds) between the system key pulse and the beginning of the data recording (see 2.4.3.9).

2.4.3.9 TIMING Switch. In NORMAL (X1) position, record length and record delay are as read from the panel. The (X2) position multiplies the time readings by two.

2.4.4 TAPE TRANSPORT ON LINE SWITCH. Depress to place recorder on line (on line light is on). The SDAS file counter will reset to one and an EOF is written on tape.

2.4.5 SYSTEM KEY INPUT. Adjust system key input for a 5-volt pulse.

2.4.6 SYSTEM INPUTS. Connect the analog inputs and the system key input.

2.4.7 RECORDING. Turn SYSTEM key switch up. The SDAS will start recording keyed by system key input and the FILE counter will count the number of records recorded.

2.4.8 STOP RECORDING. When the recording is complete, deactivate the system in the following order:

1. Set SYSTEM key switch to STOP.
2. Depress tape transport ON LINE switch (on line light off).
3. Depress tape transport REWIND pushbutton.
4. Remove analog and SYSTEM key inputs.

2.5 POWERING DOWN

There is only one critical step that must be performed before powering down. The tape transport must be taken off line first; depress ON LINE switch (ON LINE light off). If tape transport is not off line first, it causes the tape transport to rewind in an illegal mode of operation.

SECTION 3
CONCEPT AND THEORY OF OPERATION

3.1 SEISMIC DATA ACQUISITION SYSTEM

The SDAS system is keyed by a 5-volt pulse on the system key input. In the case of seismic data this pulse would be the time break or shot time of the air gun or sparker. Once keyed, the system sequentially writes an 18-character (6 bits/character) header record (see Figure 4). These characters are written at the rate of 50 KHz which takes approximately 0.4 msec. The first six characters contain date and time (hour, minutes, seconds) information from the system's digital clock. The next two characters are the sample rate, record delay, and record length switch settings. The remaining 10 characters are the switch settings of 15 BCD switches which may be used to code additional information on the tape header.

A sample delay counter begins counting following the header. This counter counts from 0 to 15 counts in 0.5 Hz (1 Hz if expanded) pulses depending on the sample delay switch. Delays from 0 seconds to 7.5 seconds (15 seconds) can be used to avoid sampling unwanted data such as the water column.

Following the sample delay, the system begins sampling data sequentially from 1 to 16 channels, depending on the end channel set on the analog to digital (A/D) converter. The sample rate is determined from the sample rate switch setting and number of channels being sampled. Sample rates are from 200 Hz to 10 KHz (for one channel and 12-bit sampling). The data sampling rate is the sample rate setting divided by the number of channels sampled. A record length counter initiates counting 0.5 Hz pulses following the record delay. The record length is determined by the record length switch which can be set from 0.5 seconds to 7.5 seconds (15 seconds in expanded mode). The 12-bit amplitude samples are loaded sequentially into one of the two tape recorder buffers. When the buffer is filled with 996 data samples (1992 characters), the incoming data is switched to the second buffer. The first buffer is written on tape. This ping-pong buffer system allows higher recording rates. At the end of the record length the system will continue to sample until the number of samples is a multiple of three. This allows rapid reading of the records into the 1108 computer which has a 36-bit word length or the CDC 3800 which has a 48-bit word length. The last record will contain less than 1992 characters.

An End of File is written after the last record. The system is now ready to receive another key pulse.

III. USERS HANDBOOK

SEISMIC DATA DISPLAY SYSTEM (SDDS)

CONTENTS

<u>SECTION</u>		<u>PAGE</u>
1	GENERAL INFORMATION	19
	1.1 Introduction	19
	1.2 Concept of Operation	19
	1.3 Specifications	19
	1.4 Front Panel Function Description of the SDDS	19
2	OPERATION	25
	2.1 Data Playback	25
	2.2 Initial Powering	25
	2.3 Tape Loading	25
	2.4 Output Signal Levels of SDDS	25
	2.5 Control Settings	26
	2.6 Power Down	27
3	CONCEPT AND THEORY OF OPERATION	33
	3.1 Concept of Operation	33
	3.2 Function Block Diagram Description	33

ILLUSTRATIONS:

Figure 1:	SDDS System Block Diagram	20
Figure 2:	SDDS Front Panel	21
Figure 3:	X-Y Recorder Connector Assignments	29
Figure 4:	Universal Graphic Recorder Connector Assignments	30
Figure 5:	Fiber Optic Recorder Connector Assignments	32
Figure 6:	SDDS Function Block Diagram	35

TABLES:

Table 1:	Output Signals	28
Table 2:	X-Y Recorder and SDDS Panel Initial Switch Setting	29
Table 3:	Universal Graphic Recorder and SDDS Panel Switch Setting for Start/Stop Operation	31
Table 4:	Universal Graphic Recorder and SDDS Panel Switch Setting for Synchronous Operation	31
Table 5:	Fiber Optic Recorder and SDDS Panel Initial Switch Setting	32

SECTION 1
GENERAL INFORMATION

1.1 INTRODUCTION

This section provides information on the operation of the Seismic Data Display System (SDDS), which includes elementary setup procedures for three display devices. Refer to Figure 1 for the System Block Diagram.

1.2 CONCEPT OF OPERATION

The basic function of the SDDS is to display in an analog format computer processed seismic profiling data. The SDDS can key the selected output device or the output device can key the SDDS.

1.3 SPECIFICATIONS

1. Data points	1977 pts per sweep	
2. Sweep Rates	0.25, 0.5, 1, 2, 5, 10 seconds	
3. Dynamic Range	36 dB	
4. Amplitude Resolution	6 bits	
5. Display Devices	Max sweep resolution	Trace width
a. Line Scan Recorder	160 lines/inch	19"
b. X-Y Recorder	64 lines/inch	10"
c. Fiber Optic Recorder	200 lines/inch	5"

1.4 FRONT PANEL FUNCTION DESCRIPTION OF THE SDDS

The following paragraphs briefly describe the function of each of the front panel controls. (Refer to Figure 2.)

1.4.1 **POWER SWITCH.** A two-position toggle, OFF and ON, which applies AC line power to the system.

1.4.2 **COMPARATOR.** Positions digital tape at the selected record when COMPARE pushbutton pressed. A "LO" indicator, red LED dot, is illuminated when the present record number is less than the desired record number. A "HI" indicator, red LED dot, is illuminated when the present record number is greater than the desired record number.

1.4.3 **COMPARE PUSHBUTTON.** Initiates positioning of tape to record selected by COMPARATOR (Section 1.4.2). The tape will stop at the end of the record indicated by the thumbwheel switch ready to display the next record.

1.4.4 **COUNTER.** The bi-directional counter indicating the current record being displayed. This counter contains start, stop, and reset pushbuttons. These only control the counter.

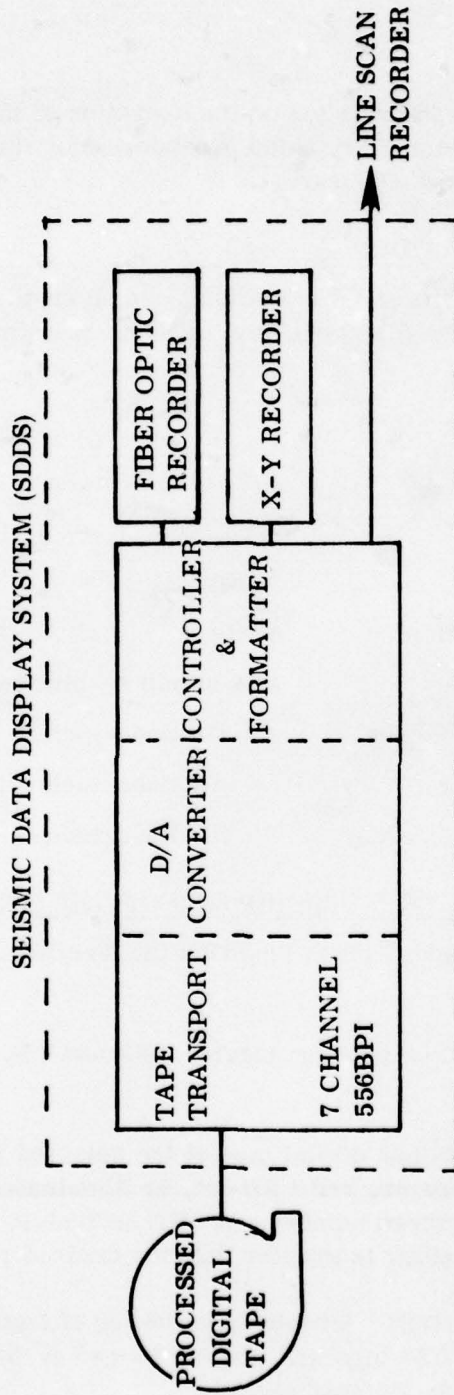

Figure 1. SDDS System Block Diagram.

SDDS FRONT PANEL

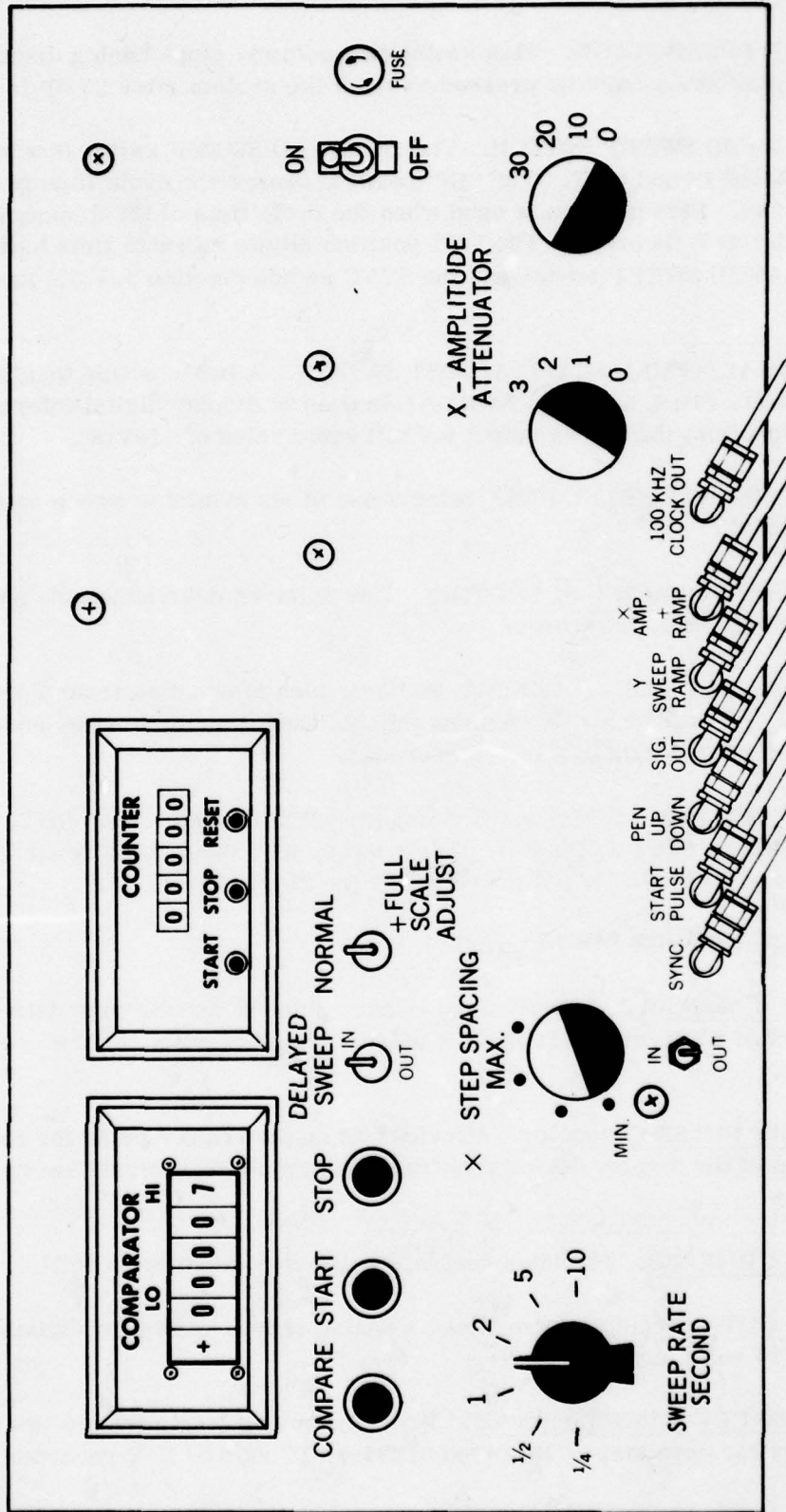

Figure 2. SDDS Front Panel.

- 1.4.5 **START PUSHBUTTON.** This switch initiates playback of the digital data.
- 1.4.6 **STOP PUSHBUTTON.** This switch immediately stops analog display process. The COMPARE pushbutton must be pressed to reset the system after STOP is pressed.
- 1.4.7 **DELAYED SWEEP SWITCH.** The DELAYED SWEEP switch is a two-position toggle switch labeled IN and OUT. The "IN" position causes the cycle time per record to increase by 300 ms. This position is used when the cycle time of the display is not zero as is the case for the X-Y recorder. The OUT position allows no extra time beyond the sweep time. The DELAYED SWEEP switch and the SYNC switch (Section 1.4.12) must be properly set.
- 1.4.8 **NORMAL/+FULL SCALE ADJUST SWITCH.** A two-position toggle switch labeled NORMAL and -FULL SCALE. NORMAL is used to display digital information. -FULL SCALE is used to adjust the analog output for full scale value of -10VDC.
- 1.4.9 **SWEEP RATE SELECTOR.** Selects one of six available sweep rates: 1/4, 1/2, 1, 2, 5, 10 seconds.
- 1.4.10 **"X" STEP SPACING SELECTOR.** This selector determines the spacing between records displayed on the X-Y recorder.
- 1.4.11 **"X"-AMPLITUDE ATTENUATOR.** Provides attenuation from 0 dB to 100 dB in steps of 1 dB. The attenuator determines the attenuation applied to the analog signal component displayed by the X-axis of the X-Y recorder.
- 1.4.12 **SYNC SWITCH.** A two-position toggle switch labeled IN and OUT. The IN position is used to synchronize SDDS start of data sweep with the display recorder. The OUT position is used if SYNC pulse is not provided for the SDDS (1.4.13.1).
- 1.4.13 **INPUT-OUTPUT CONNECTORS**
- 1.4.13.1 **SYNC Connector.** Accepts input trigger pulse to synchronize data display recorder with SDDS (if SYNC switch is IN). A pulse is not necessary if SYNC switch is OUT. (Pulse is 5 volts.)
- 1.4.13.2 **START PULSE Connector.** Provides an output trigger pulse for each record to initiate the sweep of the display device required when the SDDS controls sweep rate. (Pulse is 5 volts, 1 ms.)
- 1.4.13.3 **PEN UP/DOWN.** Provides control for the X-Y recorder's PEN.
- 1.4.13.4 **SIG. OUT Connector.** Provides an analog representation of digital data to the display device (± 10 volts max.).
- 1.4.13.5 **"Y" SWEEP RAMP Connector.** Provides analog levels from 0 to +10 volts in 1,977 steps (5 mv for each step). Required to drive "Y" axis of X-Y recorder.
- 1.4.13.6 **"X"-AMP. +RAMP Connector.** Provides the X-Y recorder with the X-axis stepping value plus the analog signal variation.

1.4.13.7 100 KHz CLOCK OUT Connector. Provides 100 KHz clock pulses to display device for synchronous operation (5-volt square wave).

SECTION 2 OPERATION

2.1 DATA PLAYBACK

The SDDS was designed to play back information on the X-Y, Line Scan, and Fiber Optics recorders. The SDDS will display data at six different sweep rates with 1,977 discrete points per sweep. The START pushbutton starts the SDDS displaying data at the sweep rate indicated by the SWEEP RATE selector switch. The STOP pushbutton stops the process. The COMPARE pushbutton initiates tape search to the selected comparator thumbwheel value. Before attempting to operate the display instruments, the user should become familiar with the operation manual for that display device. The SDDS was designed for the following recorders.

1. X-Y Recorder, HP Model 7044a/7045a,
2. Universal Graphic Recorder (Line Scan Recorder),
3. Fiber Optics-Cathode Ray Tube Visicorder Oscillograph, Honeywell Model 1856A.

2.2 INITIAL POWERING

Before operating the SDDS, study the functional description of the front panel controls and connectors given in Section 1.4.

Turn system on. The counter will display all 8's. Depress the RESET button and then the START button on the counter. The counter's LEDs will display all zeros.

2.3 TAPE LOADING

Before loading the tape, study the functional description of the DIGI-DATA Tape System (Digital Tape Formatter, Dual Buffer and Digital Tape Transport).

1. Power up the DIGI-DATA Tape System.
2. Turn the tape formatter switch to READ.
3. Remove write ring located on the inner diameter of the tape reel.
4. Load tape on tape drive. Refer to drawing under the cover of the Digital Tape Transport for proper tape threading path.
5. Depress the tape drive's LOAD button. The tape will advance to LOAD point and halt.
6. Depress the tape drive's ON LINE button. The tape drive's ON LINE lamp will glow. Make sure the RING light is off.

2.4 OUTPUT SIGNAL LEVELS OF SDDS

The signal levels are given in Table 1.

2.5 CONTROL SETTINGS

2.5.1 X-Y RECORDER SETUP AND CALIBRATION

1. Make the connection shown in Figure 3.
2. Set the switches as shown in Table 2.
3. Depress the "X" pushbutton on the X-Y recorder and adjust the pen to the zero position on the chart.
4. Depress the "Y" pushbutton on the X-Y recorder and adjust the pen to the zero position on the chart.
5. Depress the START pushbutton.
6. Sweep Separation Adjustment. Turn "Y" range vernier, on the X-Y plotter, slowly clockwise until desired separation is sufficient. Try next lower range scale if separation is insufficient. If number of steps displayed is insufficient, increase "X Step" spacing, on the SDDS, until sufficient.
7. Sweep Length Adjustment. Turn "X" range vernier, on the X-Y plotter, slowly clockwise until sweep length is sufficient. Try next lower range if necessary.
8. Analog Signal Amplitude Adjustment. Decrease the attenuation on the SDDS "X Amplitude Attenuator" until analog signal variation is sufficiently large.
9. Insert new chart paper.
10. Set the COMPARATOR count to the record desired to start displaying analog data. Depress the COMPARE pushbutton.
11. When the count is reached, depress the START pushbutton.
12. Press the STOP pushbutton when the COUNTER is at the last record to be displayed.

2.5.2 UNIVERSAL GRAPHIC RECORDER SETUP AND CALIBRATION

1. Make the connection as shown in Figure 4.
2. There are two basic modes in which the recorder may be utilized:
 - a. Start/Stop: Refer to Table 3 for initial switch setting.
 - b. Synchronous: Refer to Table 4 for initial switch setting.
3. Depress the SDDS START pushbutton.
4. Increase the UGR's marking intensity verniers (scale and signal) until the record quality is satisfactory. Halt the SDDS by pressing the STOP pushbutton.
5. Upon completion of step 4, set the COMPARATOR to the desired record number. Depress the COMPARE pushbutton.

6. Depress and hold the paper advance pushbutton on the UGR for gap in display record. Release when desired gap is achieved.
7. Depress the START pushbutton.
8. The display recorder will begin displaying data from the specified record and continue until the end of a magnetic tape file is reached or until the STOP pushbutton is pressed.
9. If there is more than one data profiling line, followed by an EOF, on the tape, repeat the process starting at step 3.

2.5.3 FIBER OPTIC RECORDER SETUP AND CALIBRATION

The procedure given is to display a wiggle trace.

1. Make the connection as shown in Figure 5.
2. Set the switches as shown in Table 5.
 - a. Depress the START Switch.
 - b. Make adjustments to the fiber optic recorder as indicated in manuals. (This is a difficult setup requiring much time.)
 - c. Press the paper advance. Set the COMPARATOR thumb-wheel switches to the location of the data that is desired for display.

An intensity modulated line scan presentation can be obtained by inserting the Signal Out of SDDS into the "Z" axis input axis of the fiber optic recorder.

An intensity modulated wiggle presentation can be obtained by paralleling the Signal Out of SDDS into the VERTICAL input and "Z" axis input of the fiber optic recorder.

2.6 POWER DOWN

There is one step that must be done before powering down. The digital tape transport must be off line first. (Depress ON LINE switch; ensure that the ON LINE lamp is extinguished.) If tape transport is not off line first, it causes the tape transport to rewind in an illegal mode of operation. Power down the remainder of the equipment in any order.

TABLE 1. OUTPUT SIGNALS

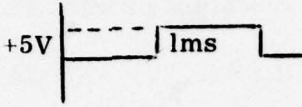
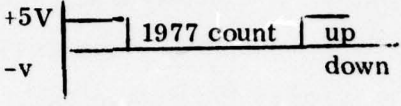
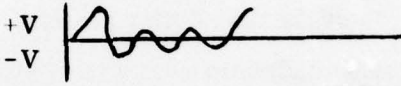
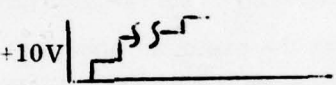
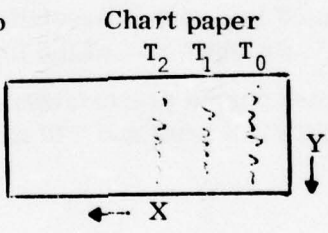
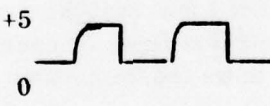
BNC	Signal	Comment
Start pulse		
Pen up/down		
Output signal		Maximum of 10V PP
Y-sweep RAMP		1977 steps (5 MV per step)
X-Amplitude + Ramp	<p>Chart paper</p> 	At the end of each 1977 count, the pen will advance along the X axis. The processed analog signal will vary this DC level.
100 KHz Clock		

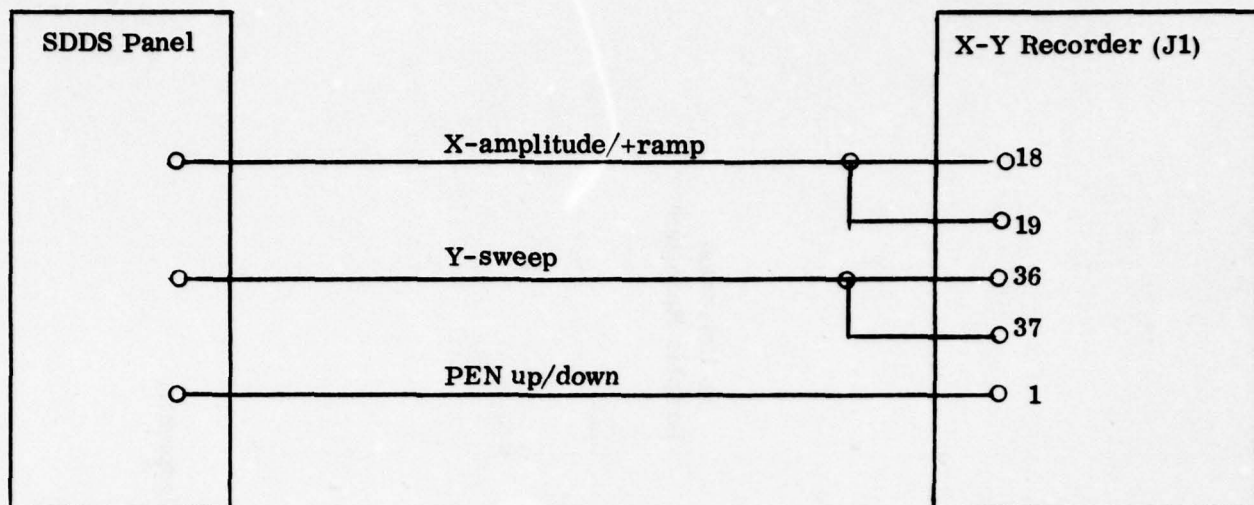

Figure 3. X-Y Recorder Connector Assignments.

TABLE 2. X-Y RECORDER AND SDDS PANEL INITIAL SWITCH SETTING

<u>Equipment</u>	<u>Switch</u>	<u>Position</u>
SDDS	Delayed Sweep	IN
SDDS	Sweep Rate	10 sec
SDDS	X STEP SPACING	MIN
SDDS	X-AMP. ATTENUATOR	30 dB
SDDS	SYNC	OUT
X-Y Recorder	LINE	ON
X-Y Recorder	CHART	Hold
X-Y Recorder	SERVO	ON
X-Y Recorder	PEN	Left
X-Y Recorder	X-RANGE	0.25
X-Y Recorder	X-RANGE VERNIER	C.C.W.
X-Y Recorder	Y-RANGE	0.5
X-Y Recorder	Y-RANGE VERNIER	C.C.W.
X-Y Recorder	X POLARITY	RT
X-7 Recorder	Y POLARITY	-UP

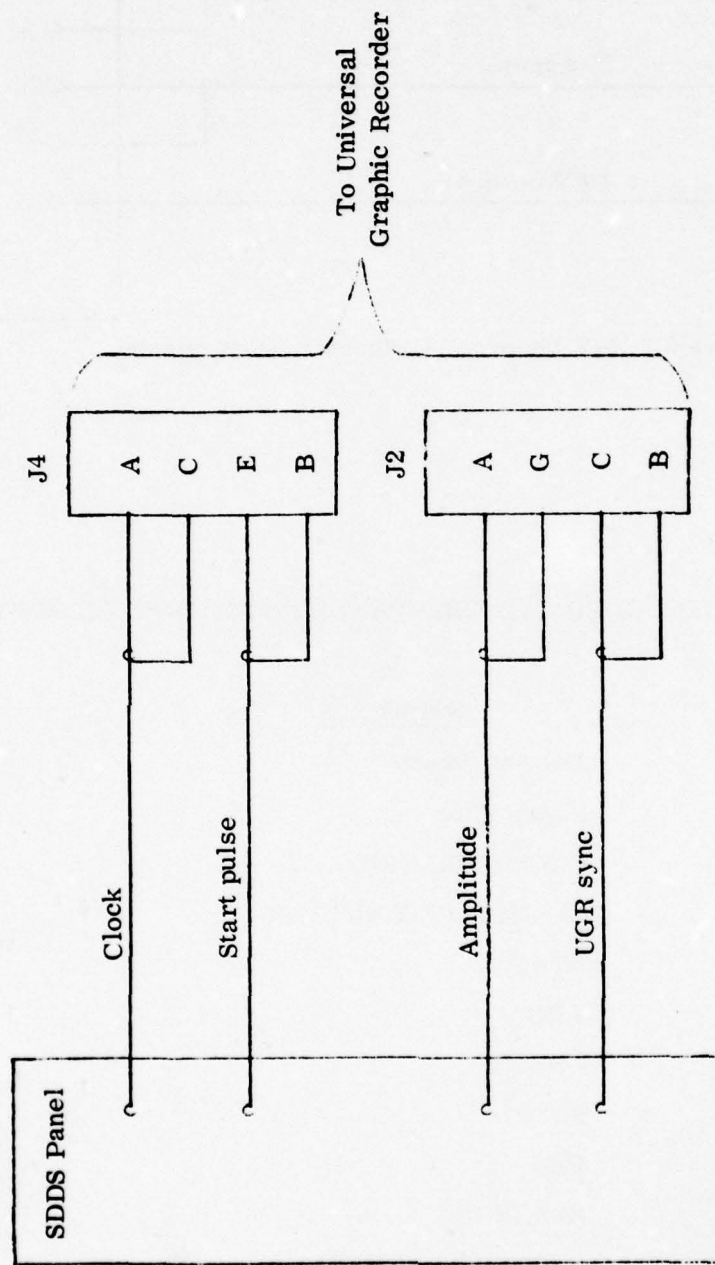

Figure 4. Universal Graphic Recorder Connector Assignments.

TABLE 3. UNIVERSAL GRAPHIC RECORDER AND SDDS PANEL SWITCH SETTING FOR START/STOP OPERATION

<u>Equipment</u>	<u>Switch</u>	<u>Position</u>
SDDS	SYNC	Out
SDDS	SWEEP RATE	1 sec
SDDS	DELAYED SWEEP	In
SDDS	NORMAL/+FULL SCALE	Normal
UGR	SEC/SCAN	1 sec
UGR	MARKER SELECT	10/S
UGR	LINES/IN	80 lines/inch
UGR	MODE SELECT	Start/Stop

TABLE 4. UNIVERSAL GRAPHIC RECORDER AND SDDS PANEL SWITCH SETTING FOR SYNCHRONOUS OPERATION

<u>Equipment</u>	<u>Switch</u>	<u>Position</u>
SDDS	SYNC	In
SDDS	SWEEP RATE	1 sec
SDDS	DELAYED SWEEP	Out
SDDS	NORMAL/+FULL SCALE	Normal
UGR	SEC/SCAN	1 sec
UGR	MARKER SELECT	10/S
UGR	LINES/IN	80 lines/inch
UGR	MODE SELECT	Continuous

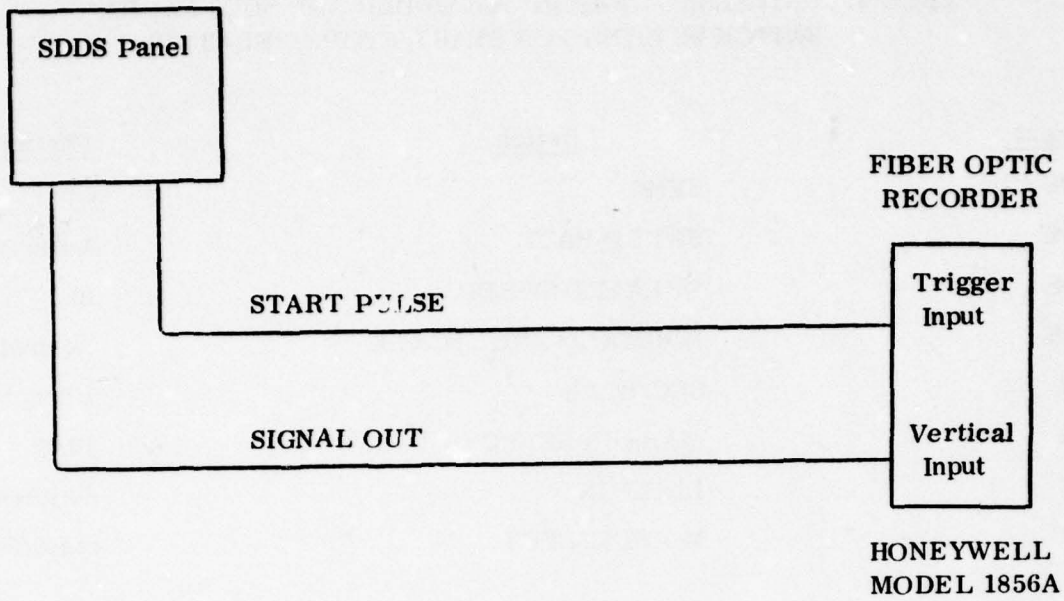

Figure 5. Fiber Optic Recorder Connector Assignments.

TABLE 5. FIBER OPTIC RECORDER AND SDDS PANEL INITIAL SWITCH SETTING.

<u>Equipment</u>	<u>Switch</u>	<u>Position</u>
SDDS	SYNC	Out
SDDS	SWEEP RATE	1/4 sec
SDDS	DELAYED SWEEP	Out
SDDS	NORMAL/+FULL SCALE	Normal
Fiber Optic	See Manual	

SECTION 3

CONCEPT AND THEORY OF OPERATION

3.1 CONCEPT OF OPERATION

The information coming from the Digital Tape Formatter is fed parallel into a 6-bit Digital-to-Analog (D/A) converter where 1,977 conversions take place per sweep. At the end of each sweep, the SDDS: (1) advances the counter by one; (2) switches to the opposite buffer in the Digital Tape Formatter. The output of the 6-bit D/A converter is available at two BNC connectors: (1) AMPLITUDE, this output has no conditioning; (2) "X" AMP./+RAMP, this output has an analog output riding on an increasing DC level (the DC level increases each sweep).

3.2 FUNCTION BLOCK DIAGRAM DESCRIPTION

The following paragraphs provide a functional description of the SDDS. (Refer to Figure 6.)

3.2.1 INPUT CONDITIONING (#1). The input conditioning circuits accept six parallel lines of data from the formatter upon command of the digital control circuits. The information is transferred to the 6-bit D/A circuit.

3.2.2 SIX-BIT D/A (#2). The 6-bit D/A circuit converts each group of 6 bits to an analog level and transfers it to the conditioned output circuit.

3.2.3 CONDITIONED OUTPUT (#3). The conditioned output circuits receive the analog level from the 6-bit D/A circuit and an increasing DC level from the variable X-sweep spacing circuits. There are two output forms: (1) buffered through an operation amplifier to the Signal OUT (BNC); (2) added to the variable X-sweep spacing circuit and buffered through an operational amplifier to the "X"-AMP./+RAMP (BNC).

3.2.4 DIGITAL CONTROL (#4). The digital control circuit accepts inputs from the clock circuit and the Formatter/Tape Drive. The Read A Character (RAC) and Go to Next Record (GNR) are controlled by the clock rate input.

3.2.5 1,977 COUNTER AND Y-SWEEP RAMP (#5). This circuit receives pulses from the Digital Control Circuit. When the count reaches 1,977, a pulse advances the Variable X-Sweep Ramp and pulses the Formatter's Go to Next Record (GNR) line.

3.2.6 CLOCK (#6). The clock section generates the timing signals that synchronize all internal operations of the SDDS. A crystal controlled oscillator generates a 100 KHz source frequency and a series of digital dividers through a SWEEP RATE selector switch, which provides the specific clock frequencies required.

3.2.7 READ OUT COUNTER (#7). The read out counter receives a pulse (REC READY) from the Formatter/Tape Drive unit when the next record has been loaded into the Formatter buffer. Each pulse is displayed as a numerical digit. The counter changes count one at a time in an appropriate direction (up or down).

3.2.8 **VARIABLE X-SWEEP SPACING (#8).** This unit increases its output DC level for each input pulse. This increasing DC level is applied to the conditioned output circuit.

3.2.9 **POWER SUPPLIES.** The SDDS has two low voltage power supplies. One provides a regulated 5-volt DC output and the other provides a regulated ± 15 -volt DC output.

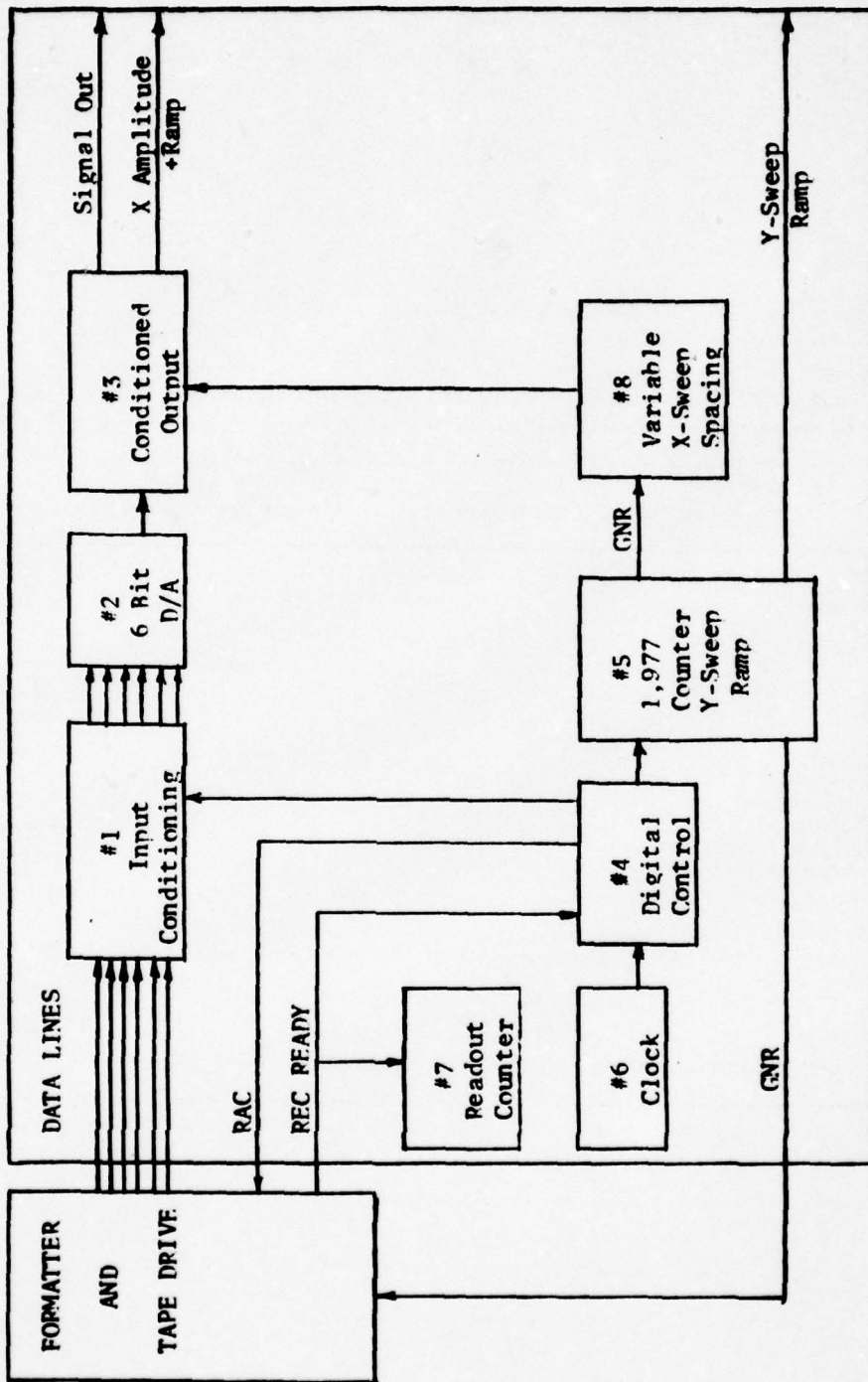
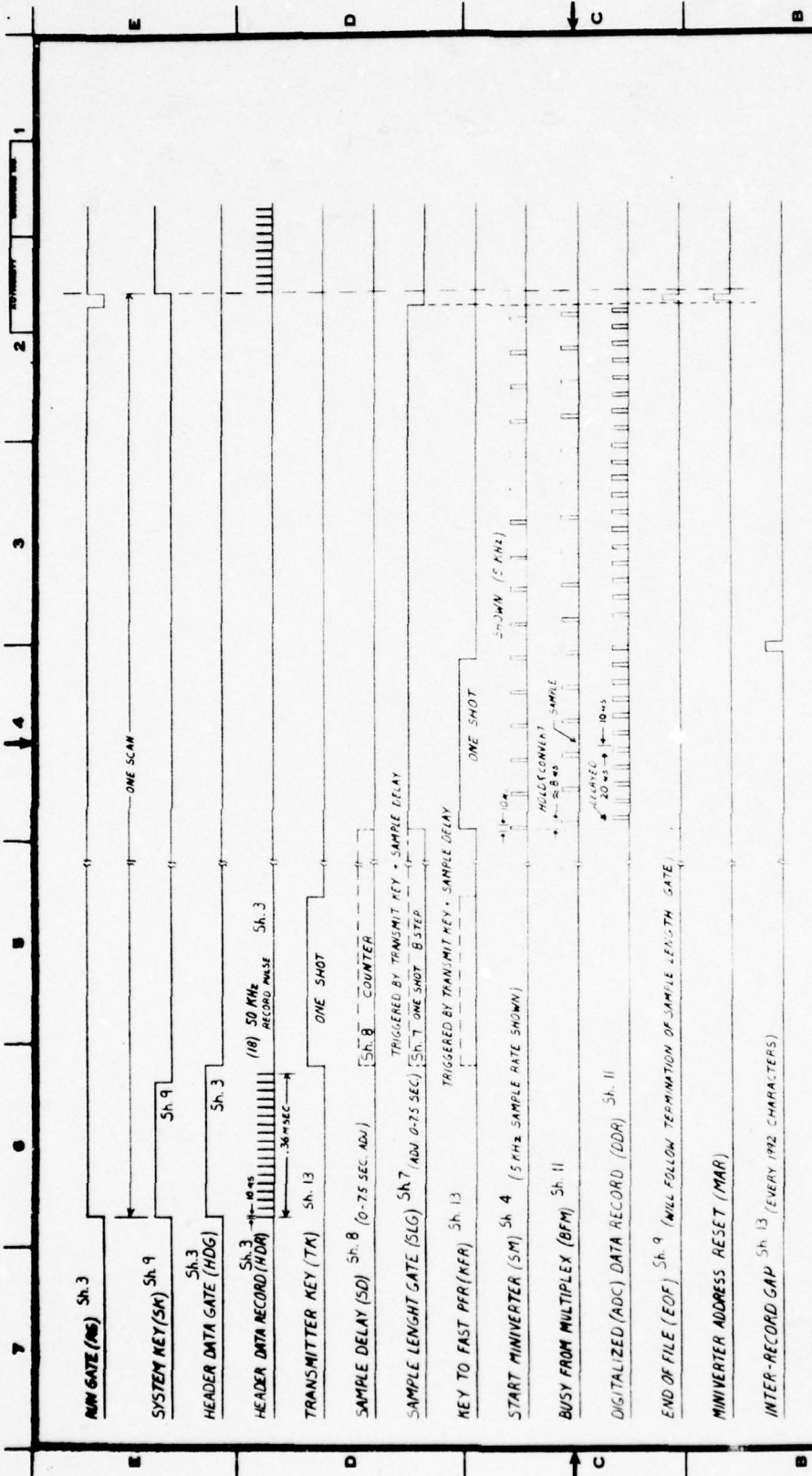

Figure 6. SDDS Function Block Diagram

APPENDIX A

SCHEMATICS

SEISMIC DATA ACQUISITION SYSTEM
(SDAS)



SYM. ZONE	DESCRIPTION	DATE	APPROVED
	REVISIONS		
	NATIONAL AERONAUTICS SPACE ADMINISTRATION GEORGE C. MARSHALL SPACE FLIGHT CENTER	DATE 9/11/76	DATE APPROVED
	GENERAL ELECTRIC		
	SDAS		
	TIMING DIAGRAM		
	SIZE C	REV. NO. 1E400C36001	REV. 0
	ISSUED	DATE	SHEET 1 OF 25
	APPROVED		
	USED ON		

2-36-502A-F

- DENOTES PIN ASSIGNMENT
- DENOTES CARD TYPE (WHEN USED)
- DENOTES CARD SLOT
- DENOTES UPPER (U) OR LOWER (L) CARD CAGE (WHEN USED)

OR

INDICATES INPUT TO OR OUTPUT FROM SYSTEM VIA PADDLE CARDS

OR

SKOWS DRAWING PAGE NUMBER OF CONNECTING CIRCUITRY

OR

REAL STATUS

THIS PAGE IS BEST QUALITY PHOTOGRAPH FROM COPY FURNISHED TO DDC

7	6	5	4	3	2	1
ADVERTISING	DATE	DESCRIPTION	NAME	REV	DATE	REV
MATERIAL				DATE OF MATERIAL		

TIME SWITCHES 1-18 ** DDR 1 DDR 2

1	PARITY	DAY	HR	MIN	SEC	SW1	SW2	SW3	SW4	SW5	SW6	SW7	SW8	SW9	SW10	SW11	SW12	SW13	SW14	SW15	SW16	SW17	SW18	RECORD	PARITY	
2	E	8	2	8	2	8	2	8	2	8	2	8	2	8	2	8	2	8	2	8	2	8	2	8	2	O
3	O	4	1	4	1	4	1	4	1	4	1	4	1	4	1	4	1	4	1	4	1	4	1	4	F	
4	F	2	8	2	8	2	8	2	8	2	8	2	8	2	8	2	8	2	8	2	8	2	8	2	RECORD	
5		1	4	1	4	1	4	1	4	1	4	1	4	1	4	1	4	1	4	1	4	1	4	1	GAP	
6		8	2	8	2	8	2	8	2	8	2	8	2	8	2	8	2	8	2	8	2	8	2	8	2	
7		4	1	4	1	4	1	4	1	4	1	4	1	4	1	4	1	4	1	4	1	4	1	4	1	

HEADER INFORMATION

* EOF = End of file
 ** DDR = Digital Data Rec'd

There is always an integer number of 36 bit computer words between record gaps, but there will never be more than 332 36 bit words between record gaps.

SYM	ZONE	DESCRIPTION	DATE	APPROVED
SIGNATURES				
DATE				
REVISIONS				
NATIONAL AERONAUTICS				
SPACE ADMINISTRATION				
GEORGE C. MARSHALL				
SPACE FLIGHT CENTER				
MISSISSIPPI TEST FACILITY				
BAY ST. LOUIS, MISSISSIPPI				
DRAWN BY: [Signature]				
CHECKED: [Signature]				
ENGINEER				
ISSUED				
SUBMITTED				
APPROVED				
DATE				
USED ON				
SIZE	DWG NO	REV	SHEET 2 OF 25	
C	1E400C36001	S		

DIGITAL TAPE FORMAT
 556 bpi OAH Parity

1	2	3	4	5	6	7
SYMBOL NO.	DESCRIPTION	NAME	QTY.	UNIT	AUTHORITY	DRAWING NO.
						1
						SIZE OF MATERIAL

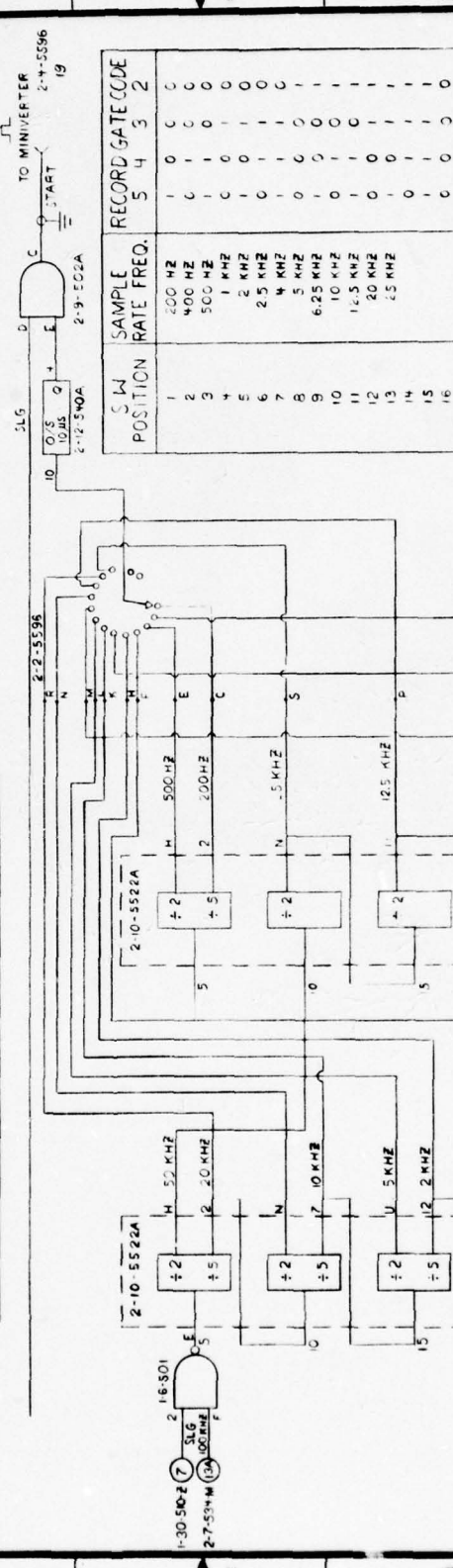
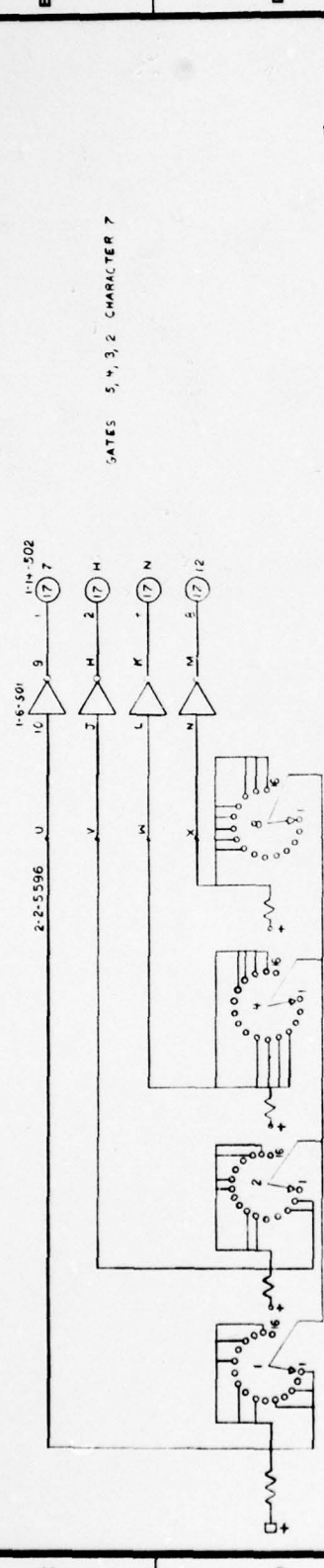

TO MINIVERTER
 2-4-5596
 PART 19
 2-9-552A
 2-12-50A

SW POSITION	SAMPLE RATE FREQ.	RECORD GATE CODE		
1	2	3	4	5
1	500 KHZ	1	0	0
2	400 KHZ	1	0	0
3	500 KHZ	1	0	0
4	1 KHZ	0	0	0
5	2 KHZ	0	0	0
6	4 KHZ	0	0	0
7	5 KHZ	0	0	0
8	6.25 KHZ	0	0	0
9	10 KHZ	0	0	0
10	12.5 KHZ	0	0	0
11	14.5 KHZ	0	0	0
12	20 KHZ	0	0	0
13	25 KHZ	0	0	0
14		0	0	0
15		0	0	0
16		0	0	0

SYM. ZONE	DESCRIPTION	DATE	APPROVED
REVISIONS			
SIGNATURES			
DATE			
DRAWN BY			
CHECKED BY			
ENGINEER			
ISSUED			
SUBMITTED			
APPROVED			
USED ON			

NATIONAL AERONAUTICS AND SPACE ADMINISTRATION
 NATIONAL AERONAUTICS AND SPACE ADMINISTRATION
 SPACE FLIGHT CENTER
 3500 BILBO AVENUE
 HUNTSVILLE, ALABAMA 35894
 GENERAL ELECTRIC
 SCAS
 SAMPLE RATE GENERATOR (SWG)

SIZE	DWG NO.	REV.
	1E40039001	1
AUTHORITY		

SHEET 4 OF 25

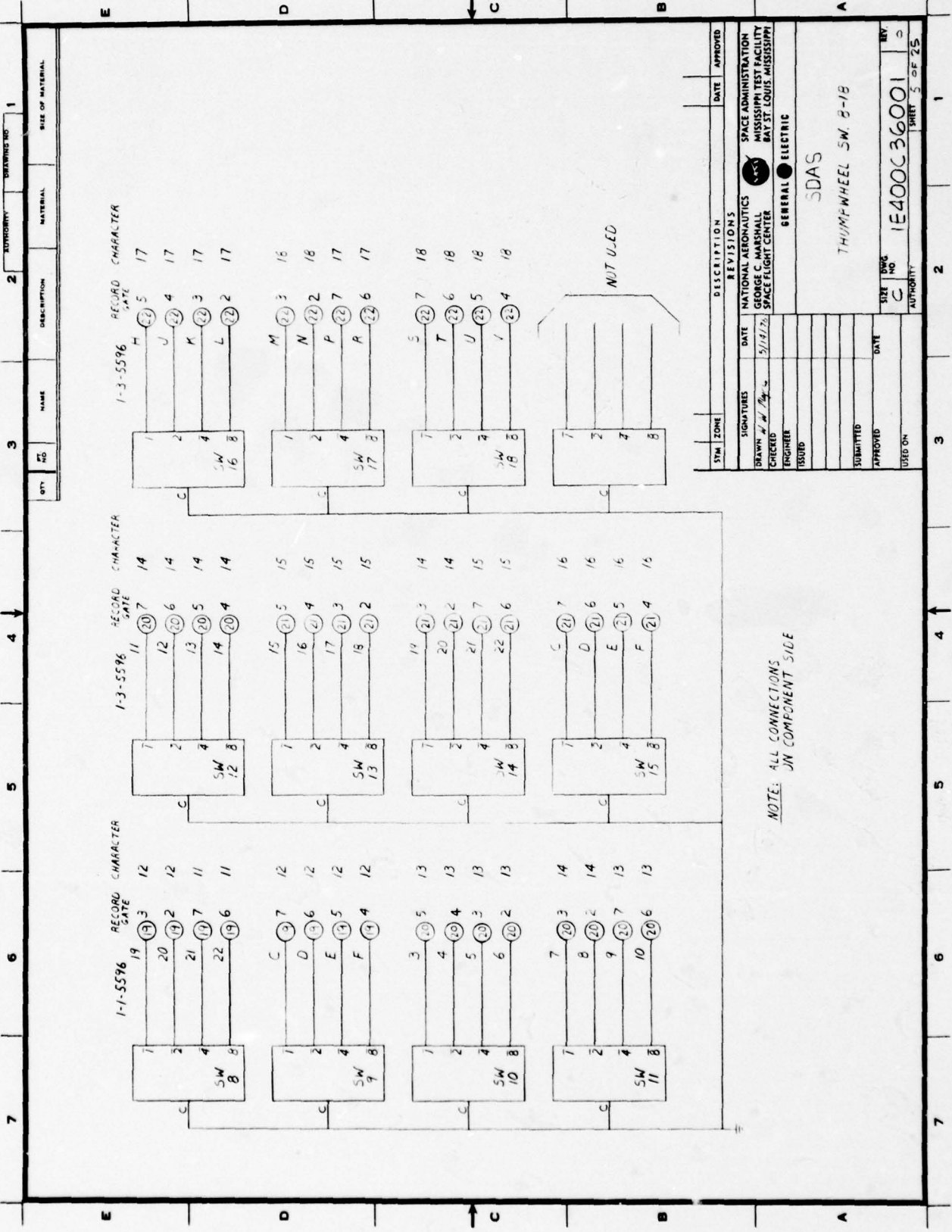

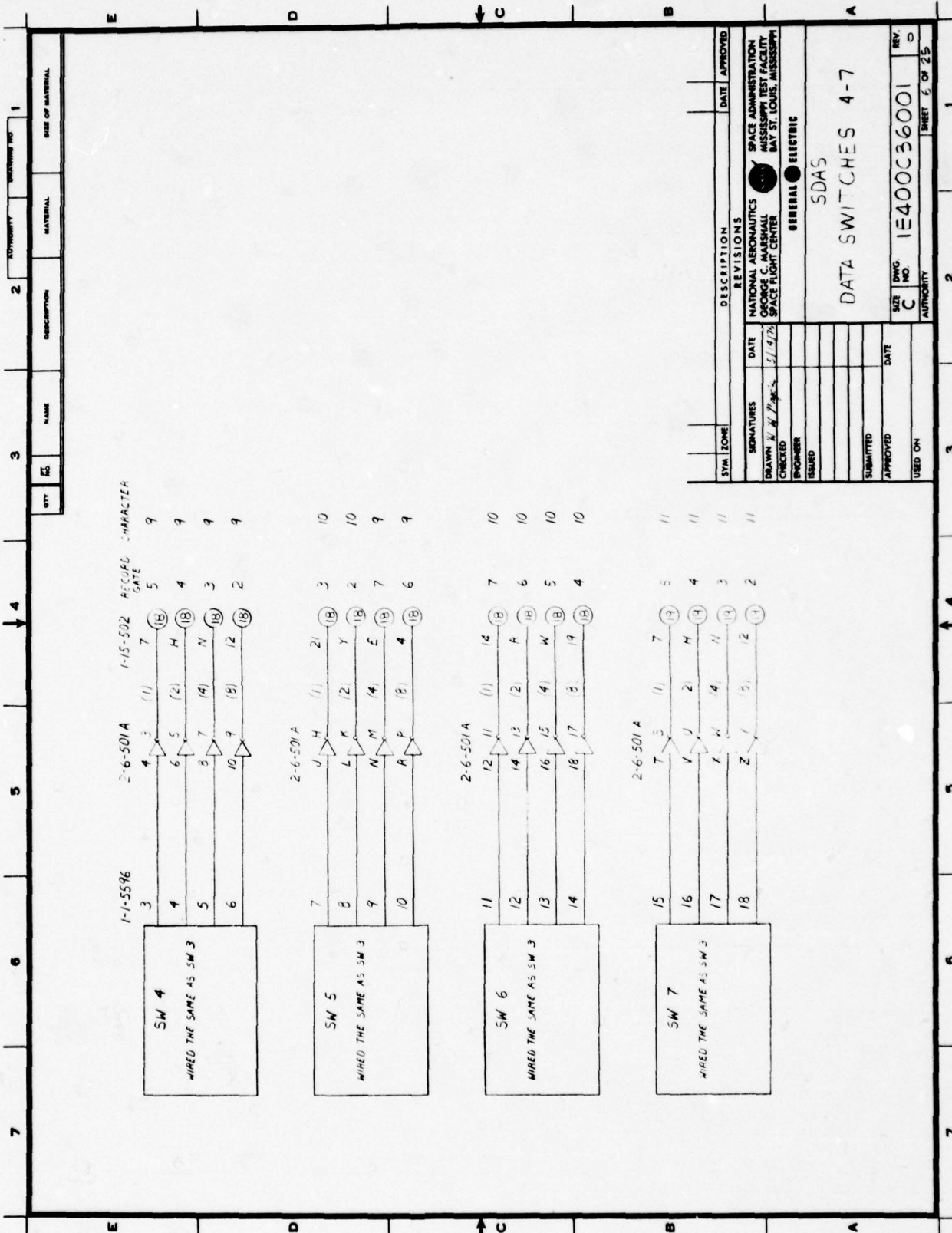

QTY	EQ	NAME	DESCRIPTION	MATERIAL	QUANTITY	REVISION NO.	1
							SIZE OF MATERIAL

SYM	ZONE	DESCRIPTION	DATE	APPROVED
REVISIONS				
SIGNATURES		DATE		
DRAWN BY H. H. ...		3-1-47		
CHECKED				
ENGINEER				
ISSUED				
SUBMITTED				
APPROVED				
USED ON				

NATIONAL AERONAUTICS GEORGE C. MARSHALL SPACE FLIGHT CENTER		SPACE ADMINISTRATION MISSISSIPPI TEST FACILITY BAY ST. LOUIS, MISSISSIPPI	
GENERAL ELECTRIC			
SDAS			
DATA SWITCHES 4-7			
SIZE	DWG. NO.	REV.	
C	1E400C36001	D	
AUTHORITY		SHEET	6 OF 25

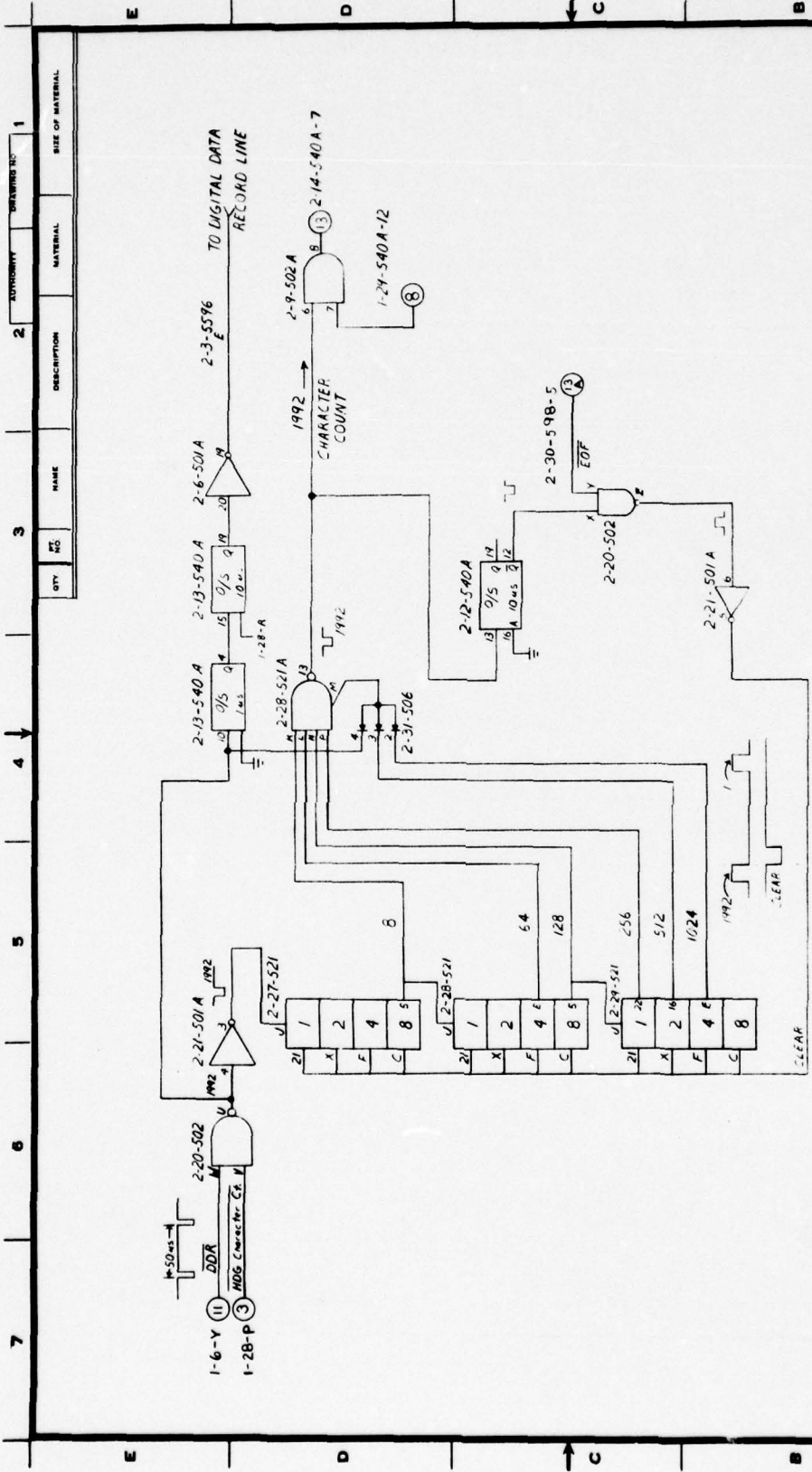

1	2	3	4	5	6	7
QTY	NAME	DESCRIPTION	MATERIAL	SIZE OF MATERIAL	AUTHORITY	DRAWING NO.

SYN	ZONE	DESCRIPTION	DATE	APPROVED
REVISIONS				
SIGNATURES	DATE	NATIONAL AERONAUTICS	SPACE ADMINISTRATION	
DESIGNED	5/12/76	GEORGE C. MARSHALL	MISSISSIPPI TEST FACILITY	
ENGINEER		SPACE FLIGHT CENTER	DAY ST. LOUIS, MISSISSIPPI	
TESTED		GENERAL ELECTRIC		
SUBMITTED		SDAS		
APPROVED		1712 CHARACTER COUNTER		
USED ON				
SIZE	DWG	NO	BY	
C	1E400C	36001	0	
AUTHORITY				SHEET 10 OF 25

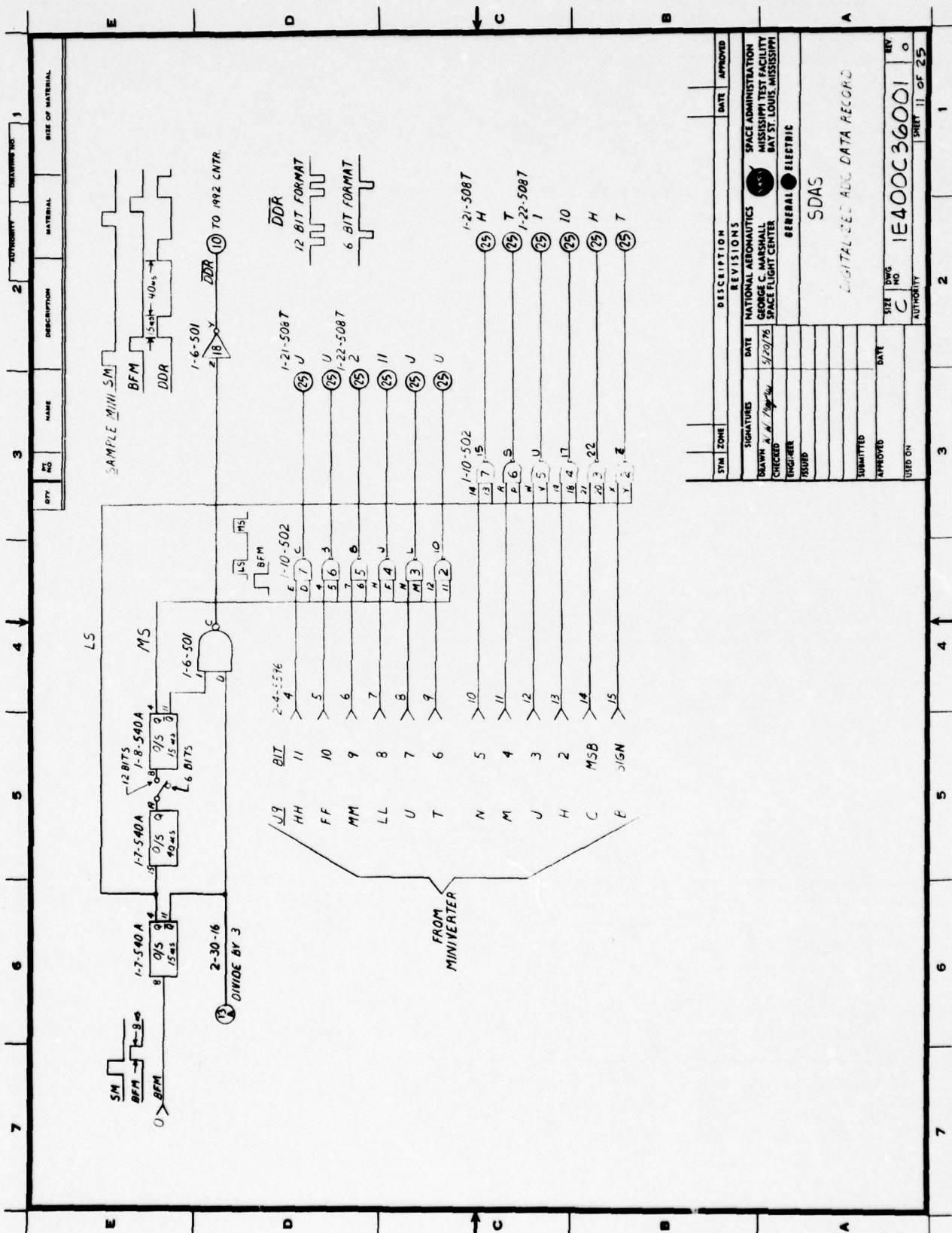

QTY	REV	NAME	DESCRIPTION	MATERIAL	THICKNESS (IN)	SIZE OF MATERIAL
					1	

SYM	ZONE	DESCRIPTION	REVISIONS	
			DATE	APPROVED
SIGNATURES		NATIONAL AERONAUTICS		
DRAWN		SPACE ADMINISTRATION		
CHECKED		GEORGE C. MARSHALL		
ENGINEER		MISSISSIPPI TEST FACILITY		
DESIGNED		SPACE FLIGHT CENTER		
		GENERAL ELECTRIC		
		SDAS		
		DIGITAL REC ADD DATA RECORD		
SUBMITTED		DATE		
APPROVED		DATE		
USED ON		DATE		
		SIZE	REV	
		C	0	
		AUTHORITY		REV
				0
				1
				2
				3
				4
				5
				6
				7
				8
				9
				10
				11
				12
				13
				14
				15
				16
				17
				18
				19
				20
				21
				22
				23
				24
				25
				26
				27
				28
				29
				30
				31
				32
				33
				34
				35
				36
				37
				38
				39
				40
				41
				42
				43
				44
				45
				46
				47
				48
				49
				50
				51
				52
				53
				54
				55
				56
				57
				58
				59
				60
				61
				62
				63
				64
				65
				66
				67
				68
				69
				70
				71
				72
				73
				74
				75
				76
				77
				78
				79
				80
				81
				82
				83
				84
				85
				86
				87
				88
				89
				90
				91
				92
				93
				94
				95
				96
				97
				98
				99
				100

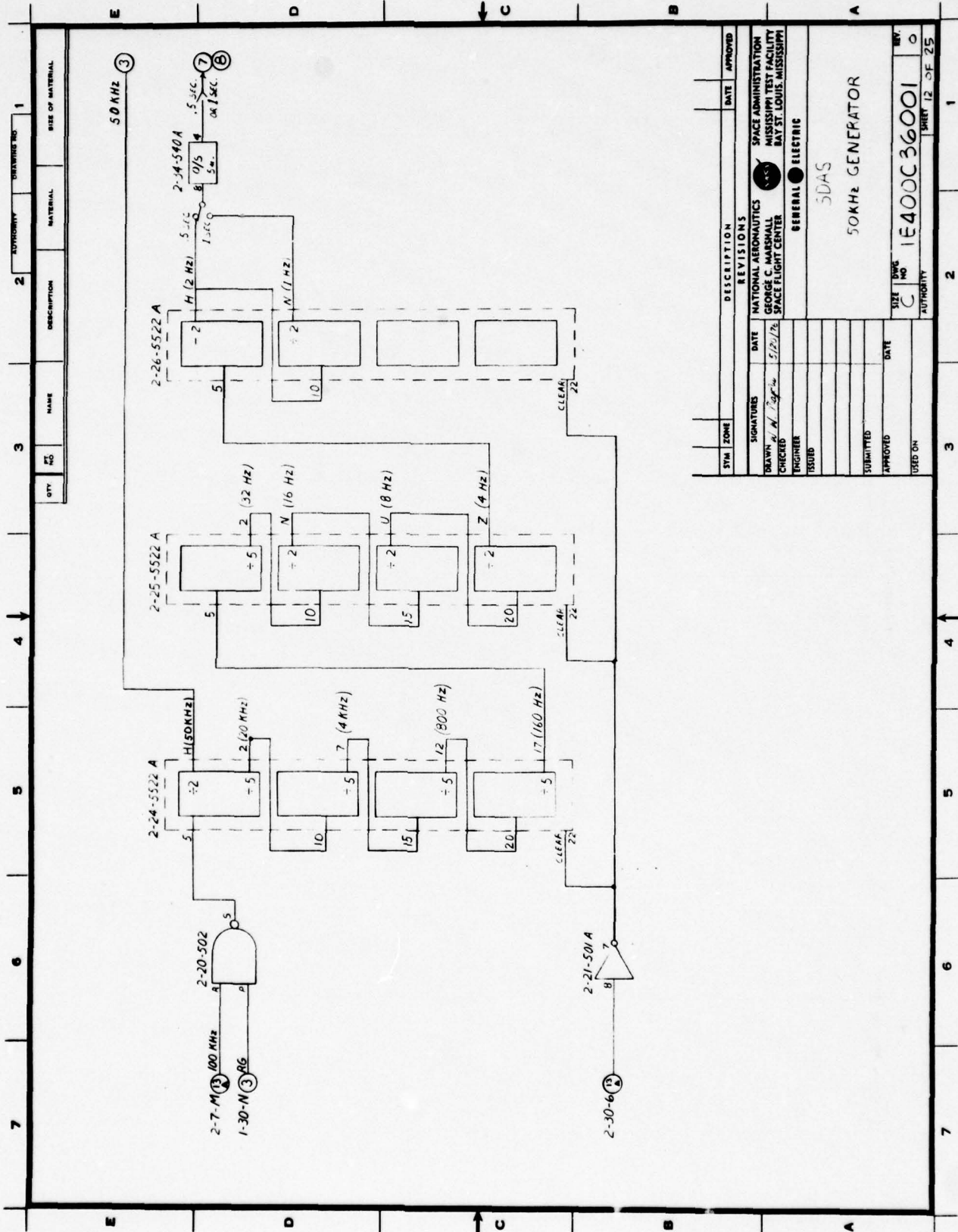

QTY	NO	NAME	DESCRIPTION	MATERIAL	SIZE OF MATERIAL

SYM	ZONE	DESCRIPTION	DATE	APPROVED
SIGNATURES				
DATE NATIONAL AERONAUTICS				
SPACE ADMINISTRATION				
GEORGE C. MARSHALL				
SPACE FLIGHT CENTER				
MAY ST. LOUIS, MISSISSIPPI				
ENGINEER				
TSSUDB				
SUBMITTED				
APPROVED				
DATE				
USED ON				
50KHz GENERATOR				
SDAS				
REV.	BY	DATE		
0	C			
AUTHORITY		SHEET 12 OF 25		

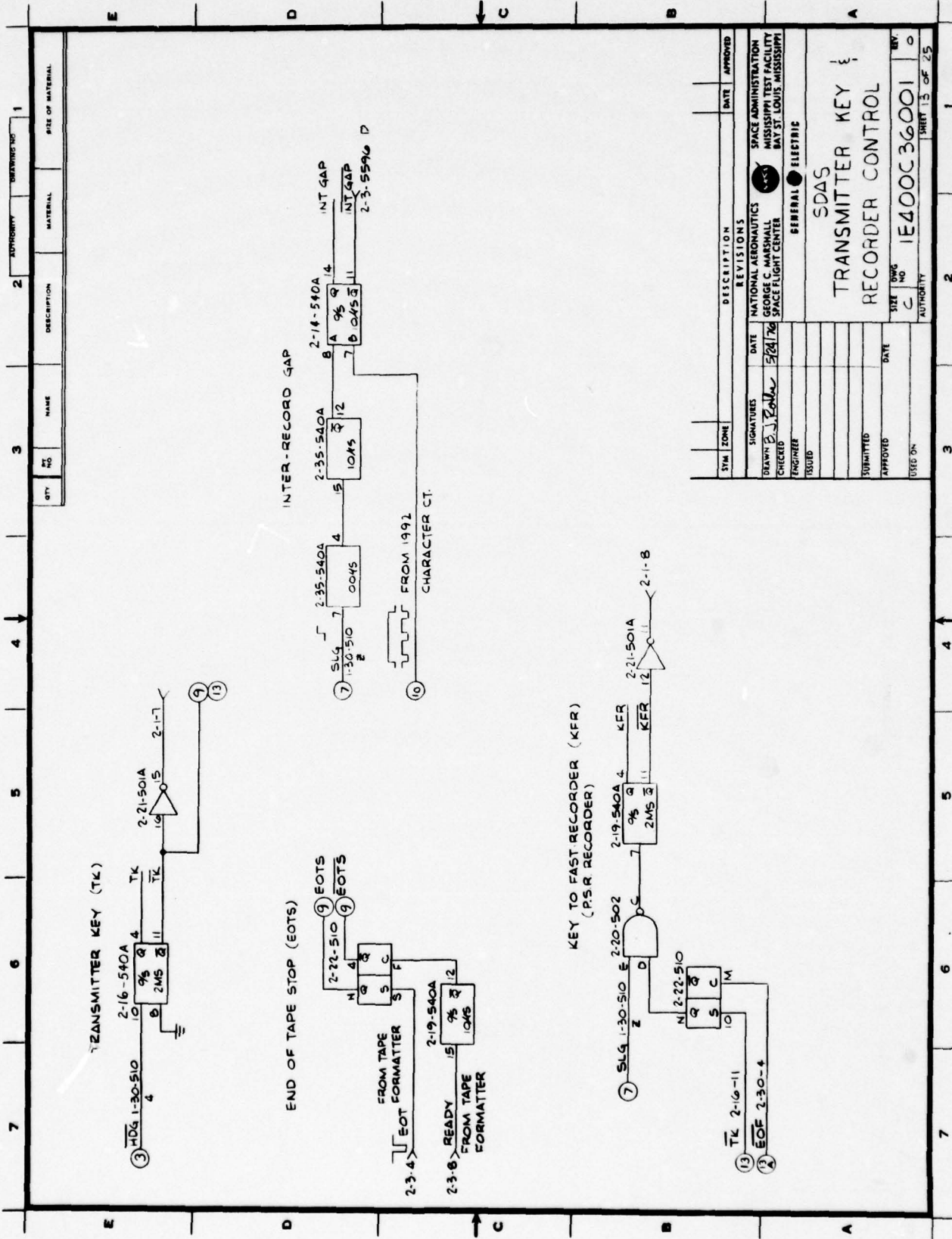

1	MEASUREMENT NO.	2	AUTHORITY
3	NAME	3	DESCRIPTION
4	NO.	4	MATERIAL
5	QTY.	5	SIZE OF MATERIAL

SYM	ZONE	DESCRIPTION	DATE	APPROVED
REVISIONS				
SIGNATURES				
DATE	NATIONAL AERONAUTICS AND SPACE ADMINISTRATION			
CHECKED	MISSISSIPPI TEST FACILITY			
ENGINEER	SPACE FLIGHT CENTER			
TESTED	BAY ST. LOUIS, MISSISSIPPI			
GENERAL ELECTRIC				
SDAS				
TRANSMITTER KEY				
RECORDER CONTROL				
SIZE	QWS	REV	BY	
C	NO	1E400C36001	o	
AUTHORITY				
USED ON				
DATE				
SUBMITTED				
APPROVED				
USED ON				

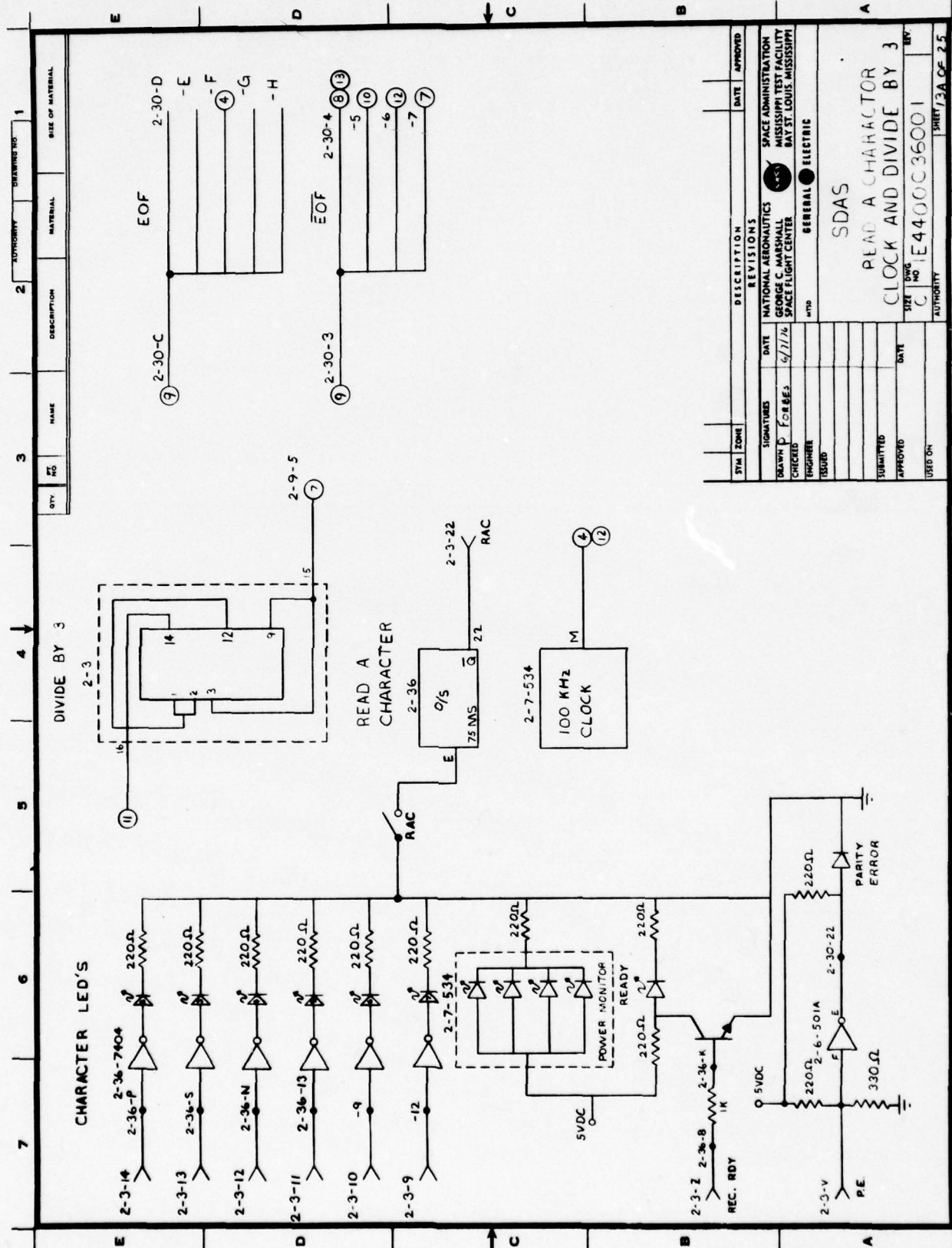

QTY	NO	NAME	DESCRIPTION	MATERIAL	SIZE OF MATERIAL

SYM	ZONE	DESCRIPTION	DATE	APPROVED

DATE	REVISIONS
6/17/76	1

SIGNATURED: NATIONAL AERONAUTICS SPACE ADMINISTRATION
 CHECKED: GEORGE C. MARSHALL MISSISSIPPI TEST FACILITY
 ENGINEER: SPACE FLIGHT CENTER
 AUTHORITY: GENERAL ELECTRIC

SDAS
 READ A CHARACTER
 CLOCK AND DIVIDE BY 3

SIZE	DWG NO	REV
C	1E4400C	36001

SYMBOL	ZONE	DESCRIPTION	DATE	APPROVED

SYMBOL	ZONE	DESCRIPTION	DATE	APPROVED

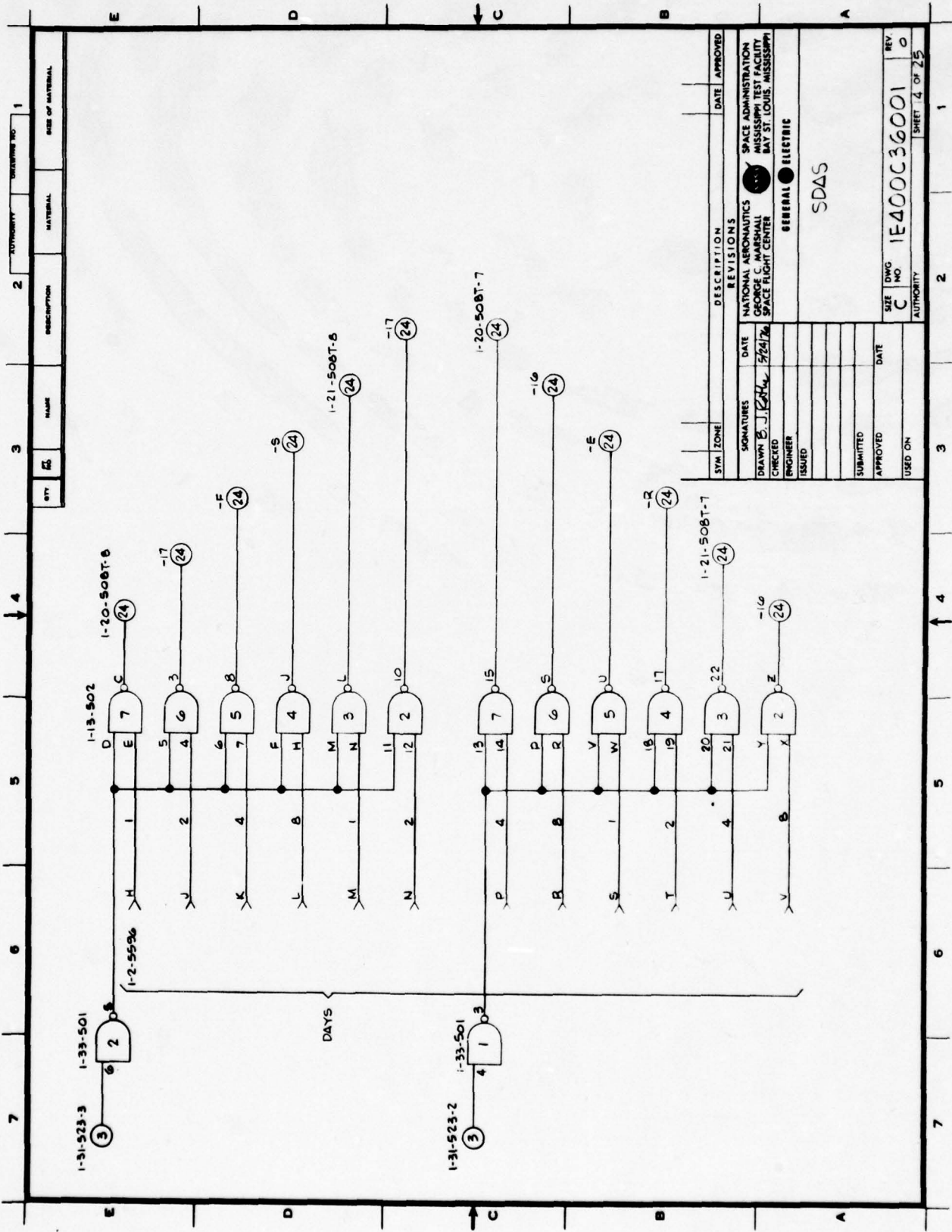

1	2	3	4	5	6	7
AUTHORITY	DESCRIPTION	NAME	DATE	BY	MATERIAL	SIZE OF MATERIAL

SYN. ZONE		DESCRIPTION		DATE APPROVED	
SIGNATURES		REVISIONS		DATE	
DATE		NATIONAL AERONAUTICS		SPACE ADMINISTRATION	
DRAWN		GEORGE C. AMERHALL		MISSISSIPPI TEST FACILITY	
CHECKED		5/24/76		SPACE FLIGHT CENTER	
ENGINEER		GENERAL ELECTRIC		SDAS	
ISSUED					
SUBMITTED					
APPROVED					
USED ON					
SIZE	ENG. NO.	REV.		AUTHORITY	
C	1E400C36001	0		SHEET 4 OF 25	

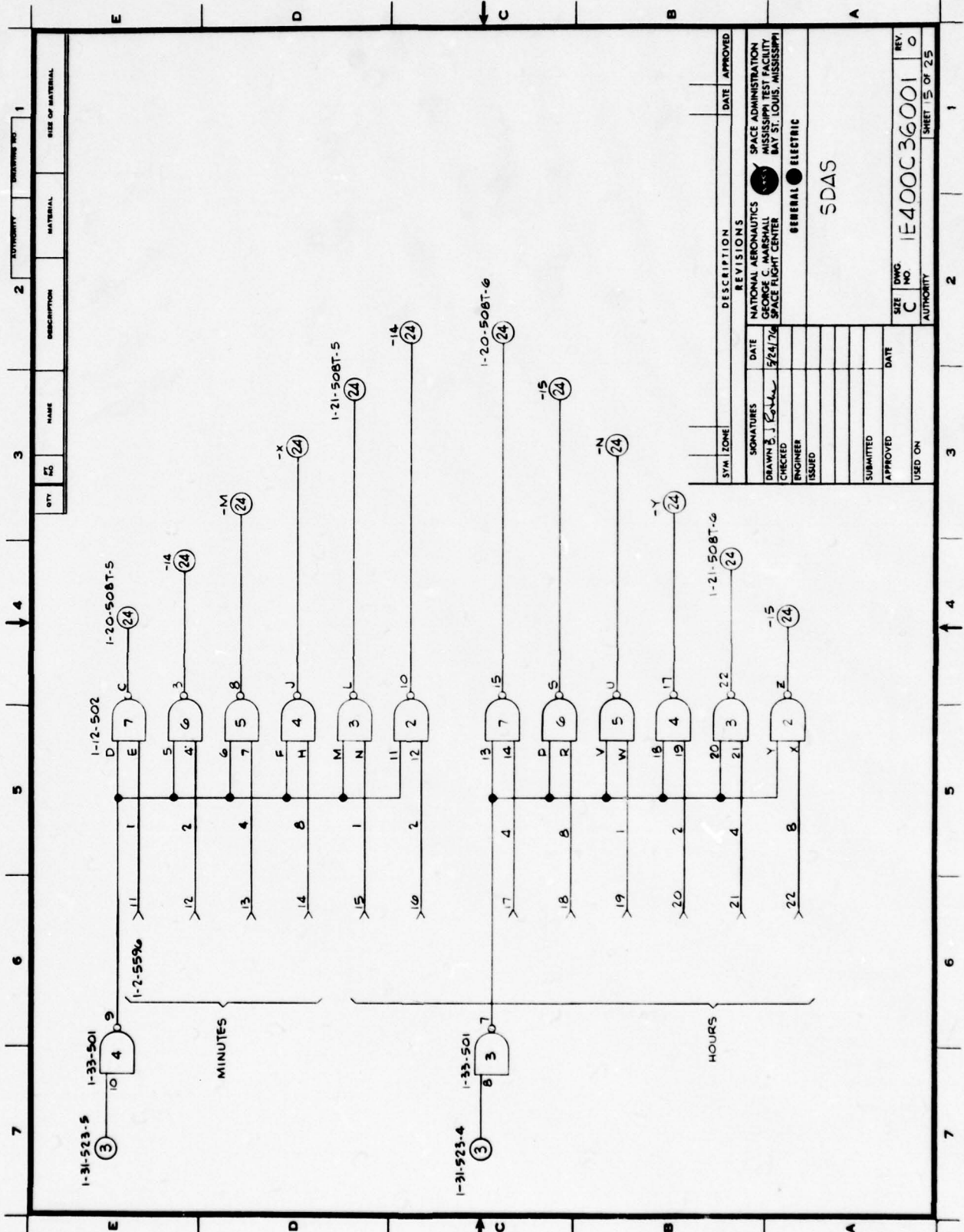

QTY	NO	NAME	DESCRIPTION	MATERIAL	QUANTITY	REVISION NO	1
							SIZE OF MATERIAL

SYN	ZONE	DESCRIPTION	DATE	APPROVED
		REVISIONS		
NATIONAL AERONAUTICS SPACE ADMINISTRATION GEORGE C. MURKIN MISSISSIPPI TEST FACILITY SPACE FLIGHT CENTER BAY ST. LOUIS, MISSISSIPPI GENERAL ELECTRIC				
SDAS				
SIGNATURES	DATE			
DRAWN BY J. K. [Signature]	5/24/76			
CHECKED				
ENGINEER				
ISSUED				
SUBMITTED				
APPROVED				
USED ON				
SIZE	DWG. NO	REV.		
C	IE400C36001	0		
AUTHORITY		SHEET	15	OF 25

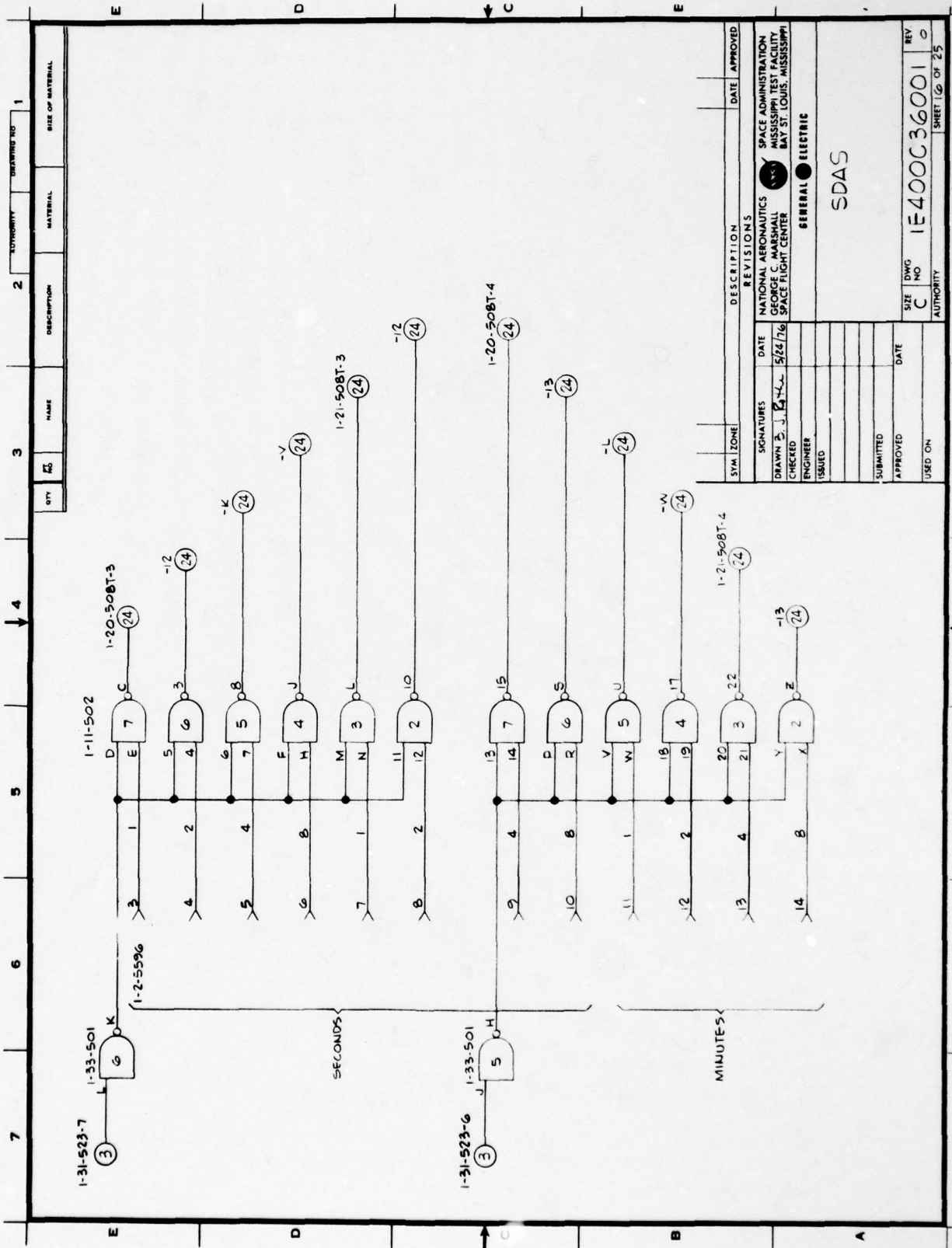

QTY	EQ	NAME	DESCRIPTION	MATERIAL	DRAWING NO	SIZE OF MATERIAL
					2	1

SYM	ZONE	DESCRIPTION	DATE	APPROVED
		REVISIONS		
SIGNATURES				
DATE				
NATIONAL AERONAUTICS				
SPACE ADMINISTRATION				
GEORGE C. MARSHALL				
MISSISSIPPI TEST FACILITY				
SPACE FLIGHT CENTER				
BAY ST. LOUIS, MISSISSIPPI				
GENERAL ELECTRIC				
SDAS				
SIZE	DWG	REV		
C	NO	0		
AUTHORITY		SHEET 6 OF 25		
1E400C36001				

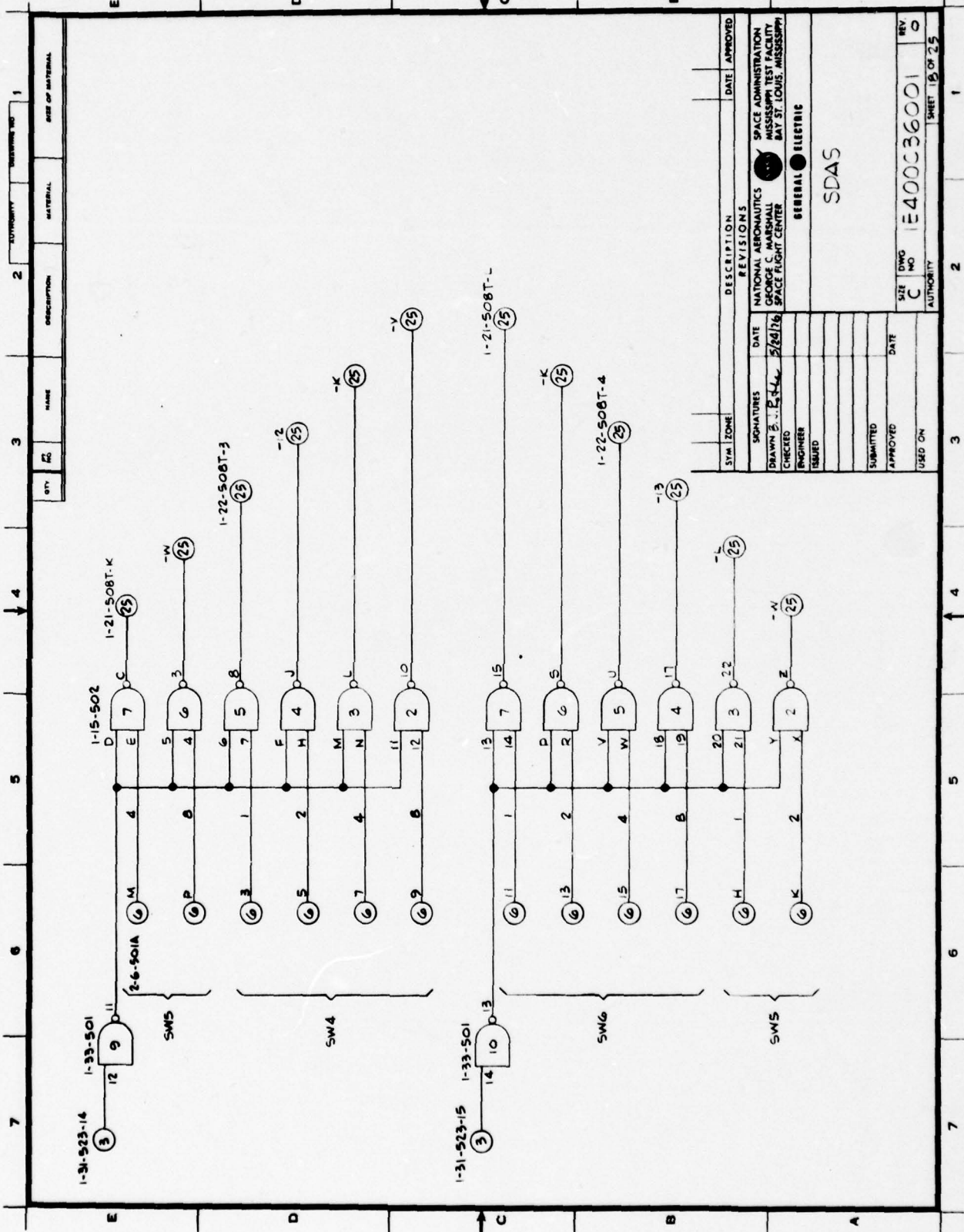

QTY.	RE.	NAME	DESCRIPTION	MATERIAL	QUANTITY	ISSUING TO	1

SYN. ZONE		REVISIONS		DATE	APPROVED
SIGNATURES	DATE	NATIONAL AERONAUTICS			
DRAWN BY: P. L. L.	2/28/76	SPACE ADMINISTRATION			
CHECKED		MISSISSIPPI TEST FACILITY			
ENGINEER		SPACE FLIGHT CENTER			
ISSUED		BAY ST. LOUIS, MISSISSIPPI			
		GENERAL ELECTRIC			
		SDAS			
SUBMITTED	DATE	SIZE DWG NO. E400036001			
APPROVED		REV. 0			
USED ON		AUTHORITY SHEET 18 OF 25			

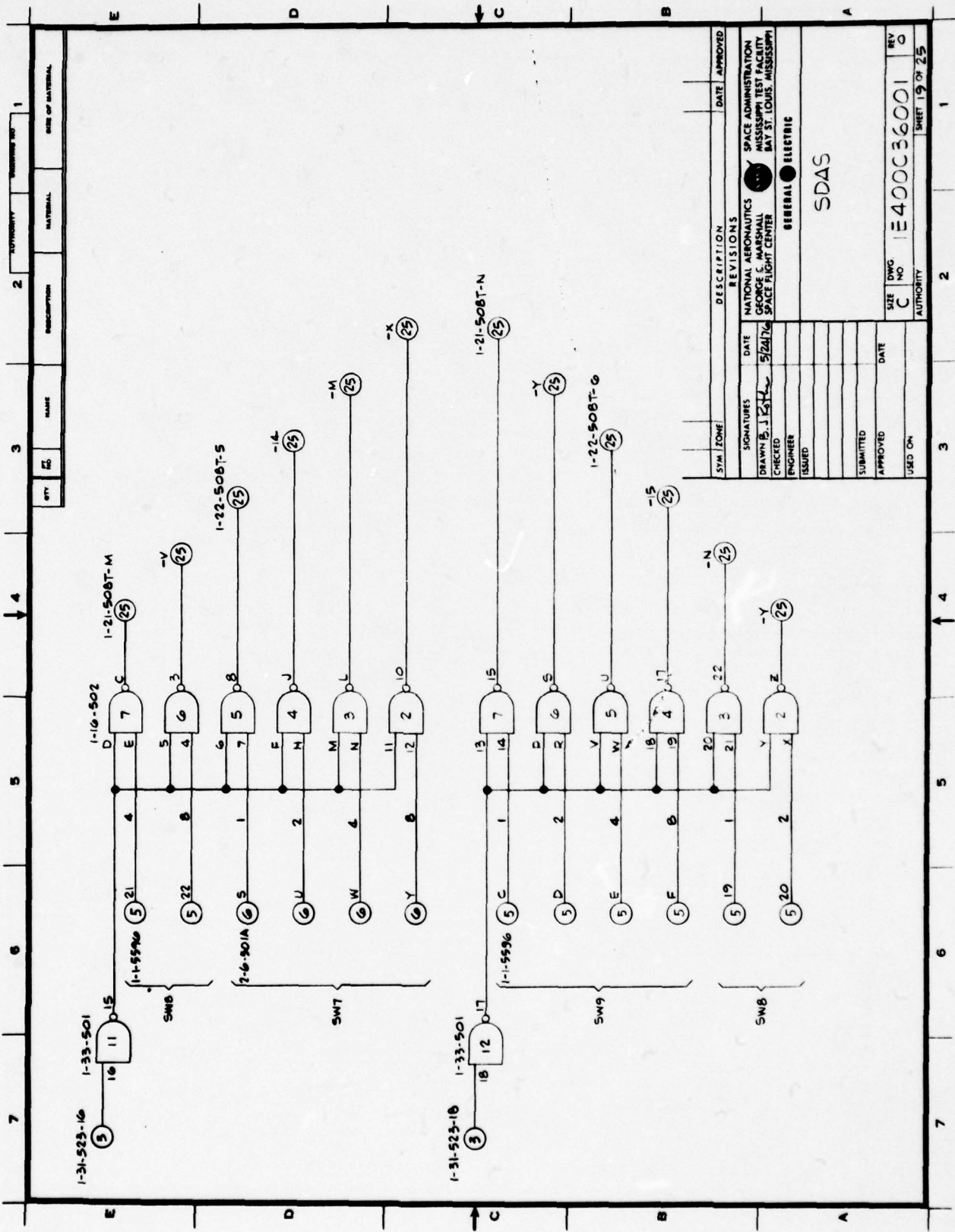

SYMBOL	DESCRIPTION	DATE	APPROVED
1	2	3	4

AUTHORITY		DRAWING NO.	
MATERIAL		REV	
DESCRIPTION		DATE	
NAME		DATE	
REV		DATE	
DATE		DATE	
CHECKED		DATE	
ENGINEER		DATE	
ISSUED		DATE	
SUBMITTED		DATE	
APPROVED		DATE	
USED ON		DATE	

SYMBOL		DESCRIPTION		DATE		APPROVED	
1		2		3		4	
5		6		7		8	
9		10		11		12	
13		14		15		16	
17		18		19		20	
21		22		23		24	
25		26		27		28	

NATIONAL AERONAUTICS		SPACE ADMINISTRATION	
GEORGE C. MARSHALL		MISSISSIPPI TEST FACILITY	
SPACE FLIGHT CENTER		BAT ST. LOUIS, MISSISSIPPI	
GENERAL ELECTRIC		SDAS	
SIZE	REV	DATE	REV
C	1	E400C36001	D
AUTHORITY	REV	SHEET	OF
		19	25

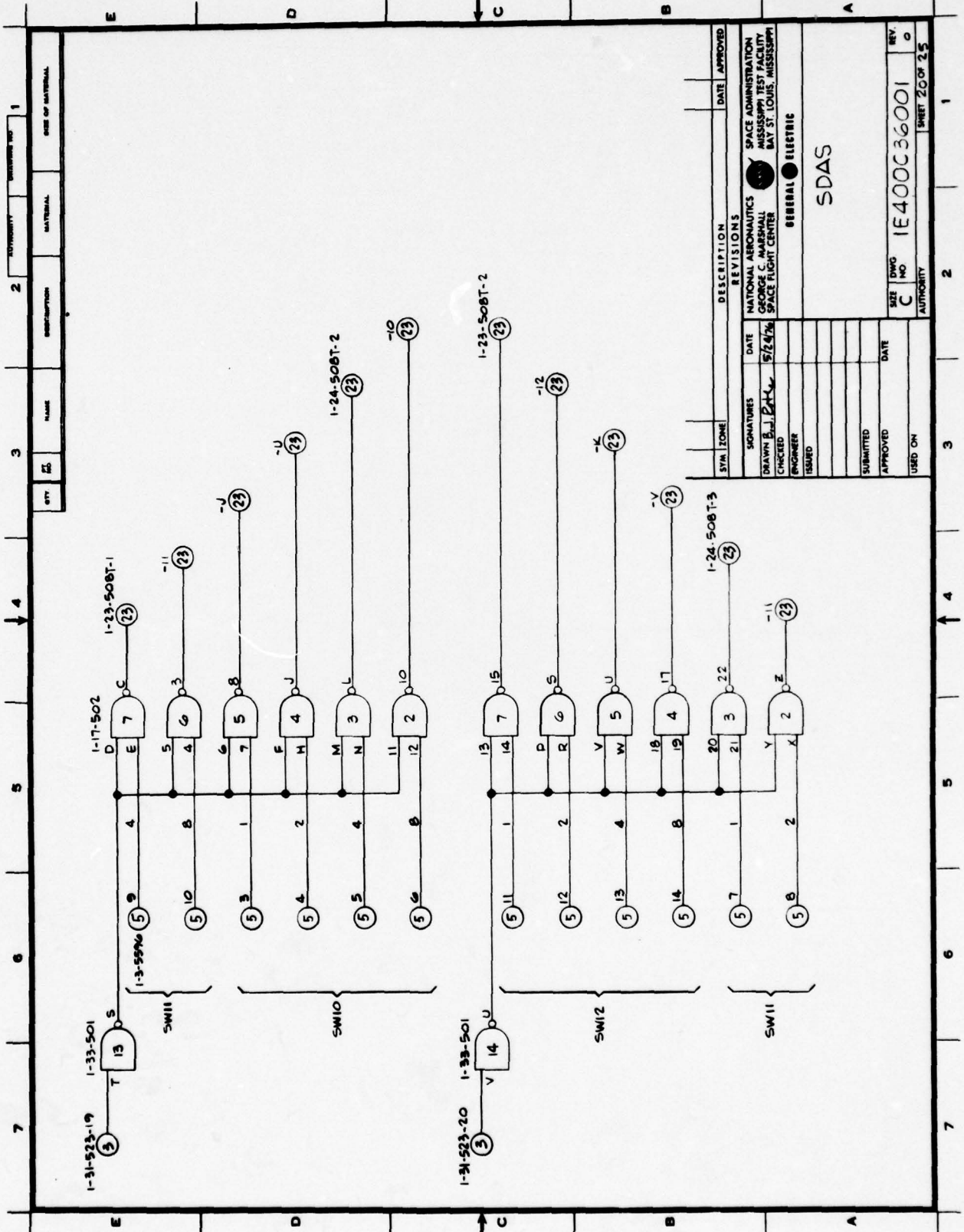

REV	DATE	NAME	DESCRIPTION	MATERIAL	QUANTITY	REVISION NO

SYN	ZONE	DESCRIPTION	DATE	APPROVED

DATE	REVISIONS

SIGNATURES		DATE	

DRAWN BY		CHECKED BY		ENGINEER		ISSUED	

SUBMITTED		DATE	

APPROVED		DATE	

USED ON		DATE	

NATIONAL AERONAUTICS		SPACE ADMINISTRATION	
GEORGE C. MARSHALL		MISSISSIPPI TEST FACILITY	
SPACE FLIGHT CENTER		BAY ST. LOUIS, MISSISSIPPI	

GENERAL ELECTRIC

SDAS

SIZE	DWG NO	REV
C	IE400C36001	0

AUTHORITY

SHEET 2 OF 2.5

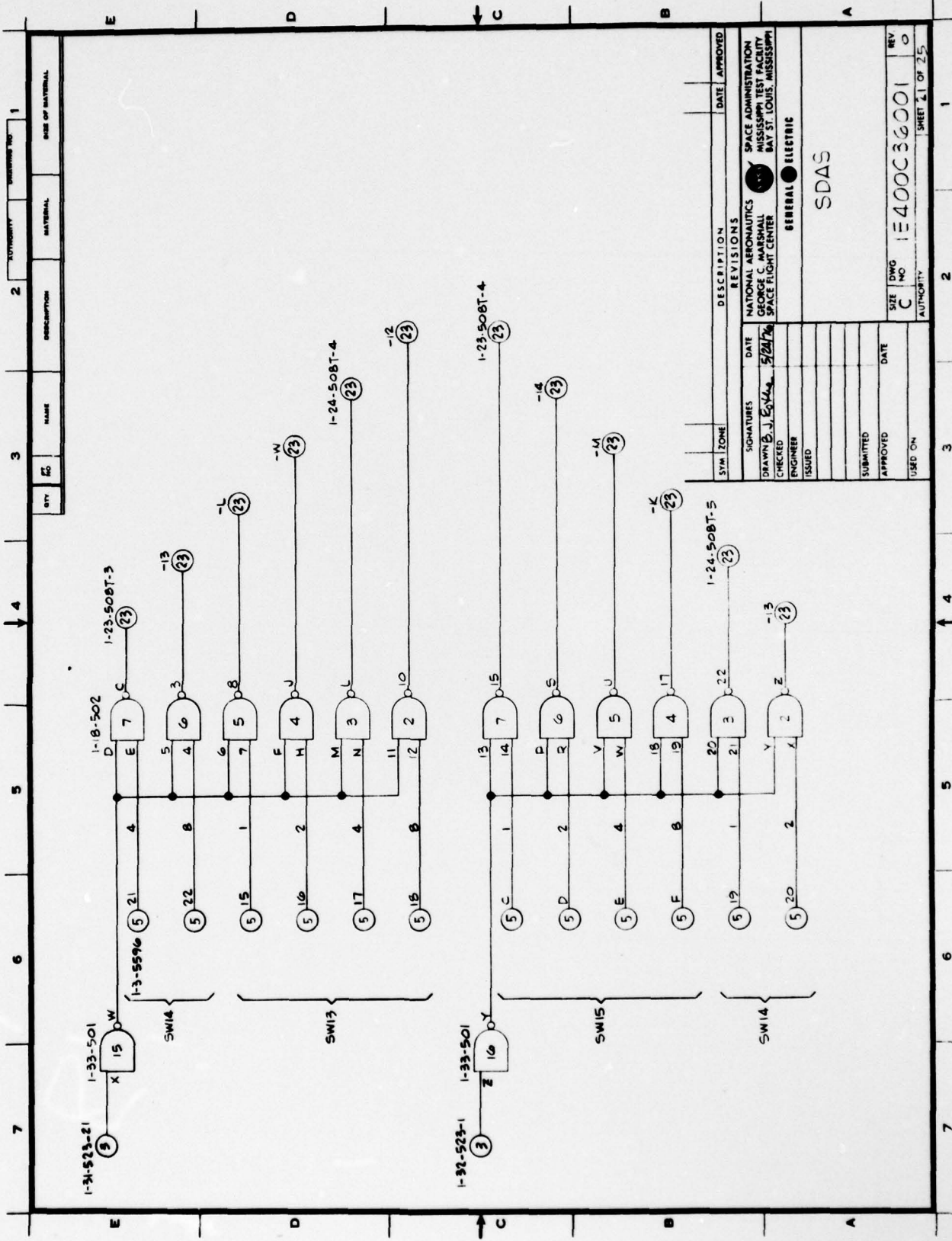

REV	DATE	NAME	DESCRIPTION	AUTHORITY	ISSUING NO

SYMBOL		DESCRIPTION	DATE	APPROVED
SIGNATURES		DATE	REVISIONS	
DRAWN BY: J. E. ...		5/24/76	NATIONAL AERONAUTICS SPACE ADMINISTRATION GEORGE C. MARSHALL SPACE FLIGHT CENTER MISSISSIPPI TEST FACILITY BAY ST. LOUIS, MISSISSIPPI	
CHECKED			GENERAL ELECTRIC	
ENGINEER			SDAS	
ISSUED				
SUBMITTED				
APPROVED				
USED ON				
SIZE	DWG NO	REV	AUTHORITY	
C	1E400C36001	0	SHEET 21 OF 25	

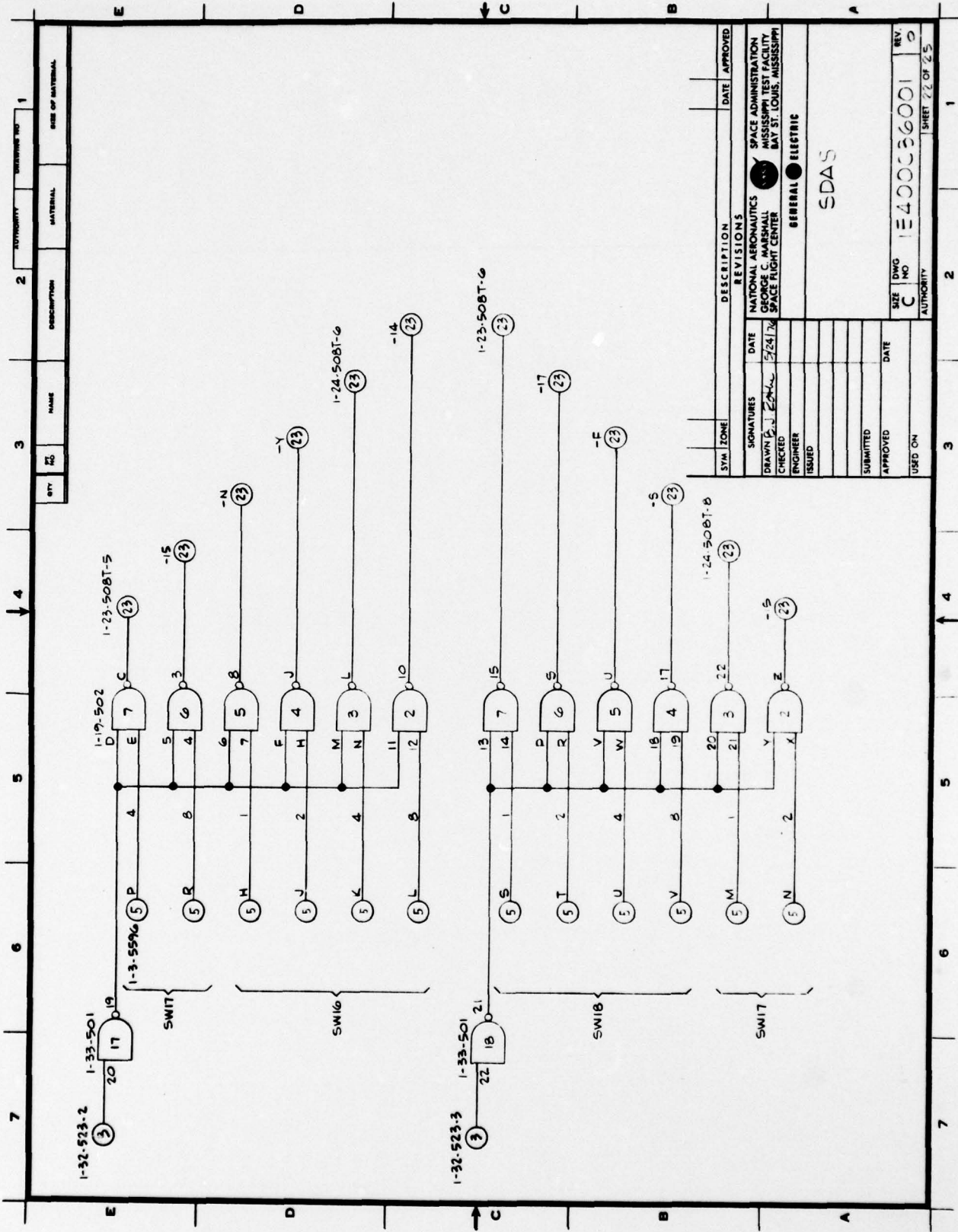

QTY	NO.	NAME	DESCRIPTION	MATERIAL	ISSUING NO.	REV.

SYMBOL		DESCRIPTION		DATE	APPROVED
REVISIONS					
SIGNATURES	DATE	NATIONAL AERONAUTICS SPACE ADMINISTRATION GENERAL ELECTRIC			
DRAWN	5/24/74	SPACE ADMINISTRATION GENERAL ELECTRIC SPACE FLIGHT CENTER BAY ST. LOUIS, MISSISSIPPI			
CHECKED		GENERAL ELECTRIC			
ENGINEER		SDAS			
ISSUED					
SUBMITTED					
APPROVED					
USED ON					
SIZE	DWG NO	REV	AUTHORITY		
C	1E400036001	0	SHEET 22 OF 25		

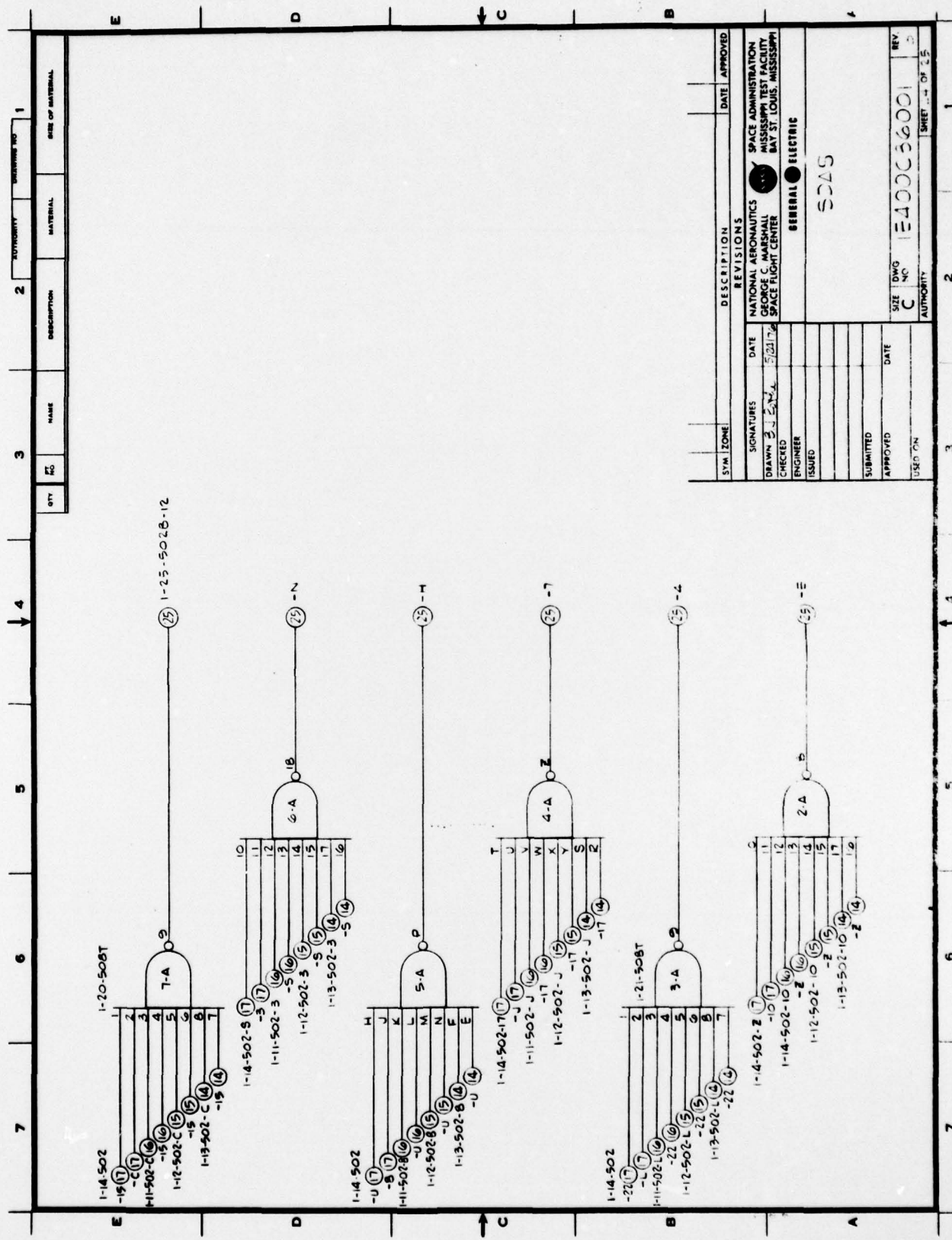

SYMBOL	DESCRIPTION	DATE	APPROVED
SIGNATURES	REVISIONS	DATE	APPROVED
DRAWN BY J. E. W. A.	NATIONAL AERONAUTICS	5/23/58	SPACE ADMINISTRATION
CHECKED BY	GEORGE C. WENDEL		MISSISSIPPI TEST FACILITY
ENGINEER	SPACE FLIGHT CENTER		BAY ST. LOUIS, MISSISSIPPI
ISSUED	GENERAL ELECTRIC		
SUBMITTED			
APPROVED			
USED ON			
SIZE	DWG NO.	REV.	
C	1E400036001	5	
AUTHORITY			

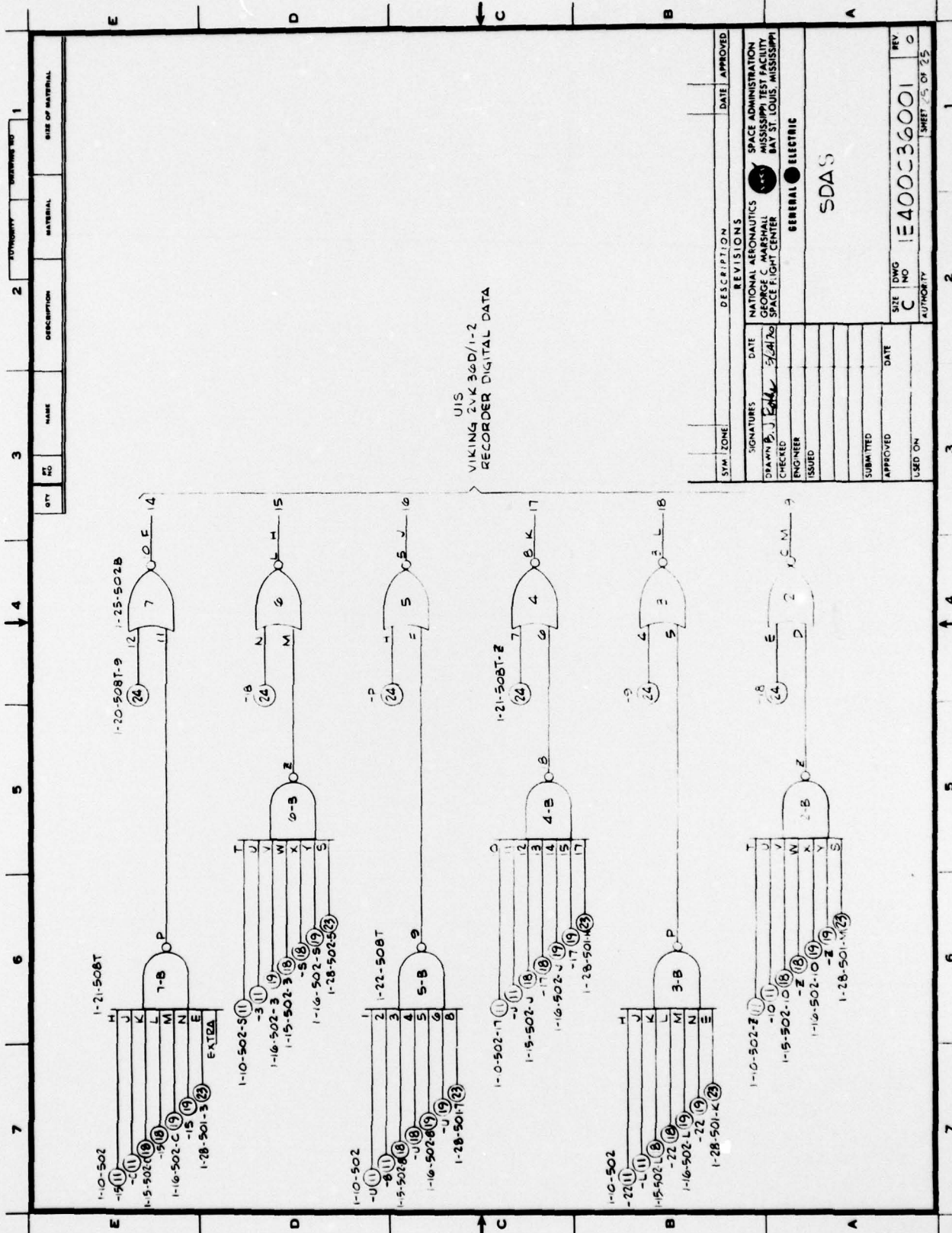

VIKING 2VK 30D/1-2
RECORDER DIGITAL DATA

QTY	NO	NAME	DESCRIPTION	MATERIAL	ORDERING NO	SIZE OF MATERIAL

SYM ZONE	DESCRIPTION	DATE	APPROVED
	NATIONAL AERONAUTICS SPACE ADMINISTRATION GEORGE C. MARSHALL SPACE FLIGHT CENTER BAY ST. LOUIS, MISSISSIPPI		
SIGNATURE	DATE	REVISIONS	
DRAWN <i>P. J. Egan</i>	5/21/60	NATIONAL AERONAUTICS SPACE ADMINISTRATION GEORGE C. MARSHALL SPACE FLIGHT CENTER BAY ST. LOUIS, MISSISSIPPI	
CHECKED		GENERAL ELECTRIC	
ENGINEER		SDAS	
ISSUED			
SUBMITTED	DATE		
APPROVED	DATE		
USED ON			
SIZE	DWG NO	REV	REV
C	1E400C36001	0	0
AUTHORITY	SHEET 15 OF 25		

APPENDIX B

SCHEMATICS

**SEISMIC DATA DISPLAY SYSTEM
(SDDS)**

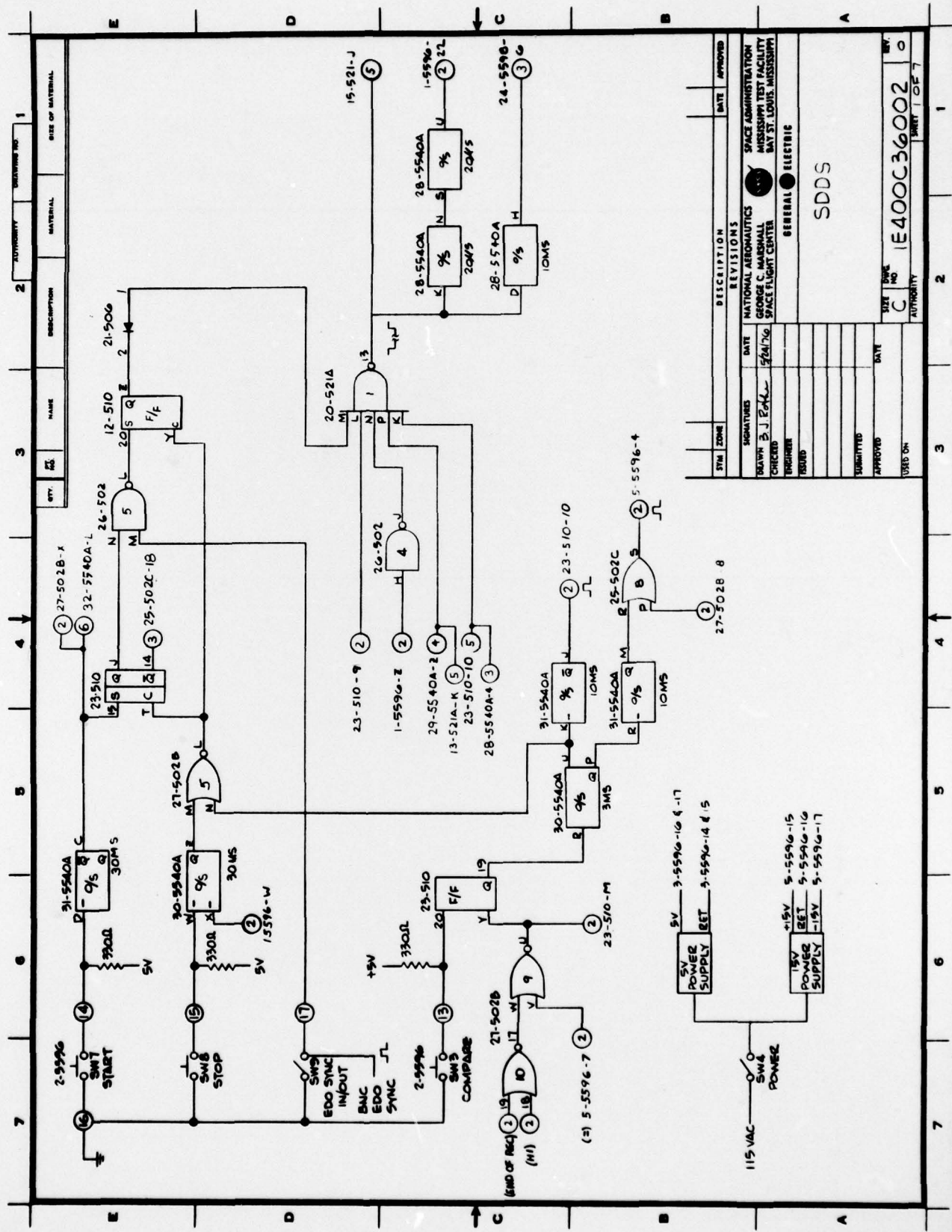

1	REV. NO.	1
2	AUTHORITY	
3	DESCRIPTION	
4	NAME	
5	QTY.	
6	MATERIAL	
7	SIZE OF MATERIAL	

SIGNATURES		DATE		REVISIONS	
DESIGNED BY	J. P. K...	DATE	5/24/76	NO.	
CHECKED BY				DATE	
ENGINEER				APPROVED	
TESTED BY				USED ON	
GENERAL ELECTRIC					
SDDS					
SIZE	NO.	1E400C36002		REV.	0
AUTHORITY				SHEET	1 OF 7

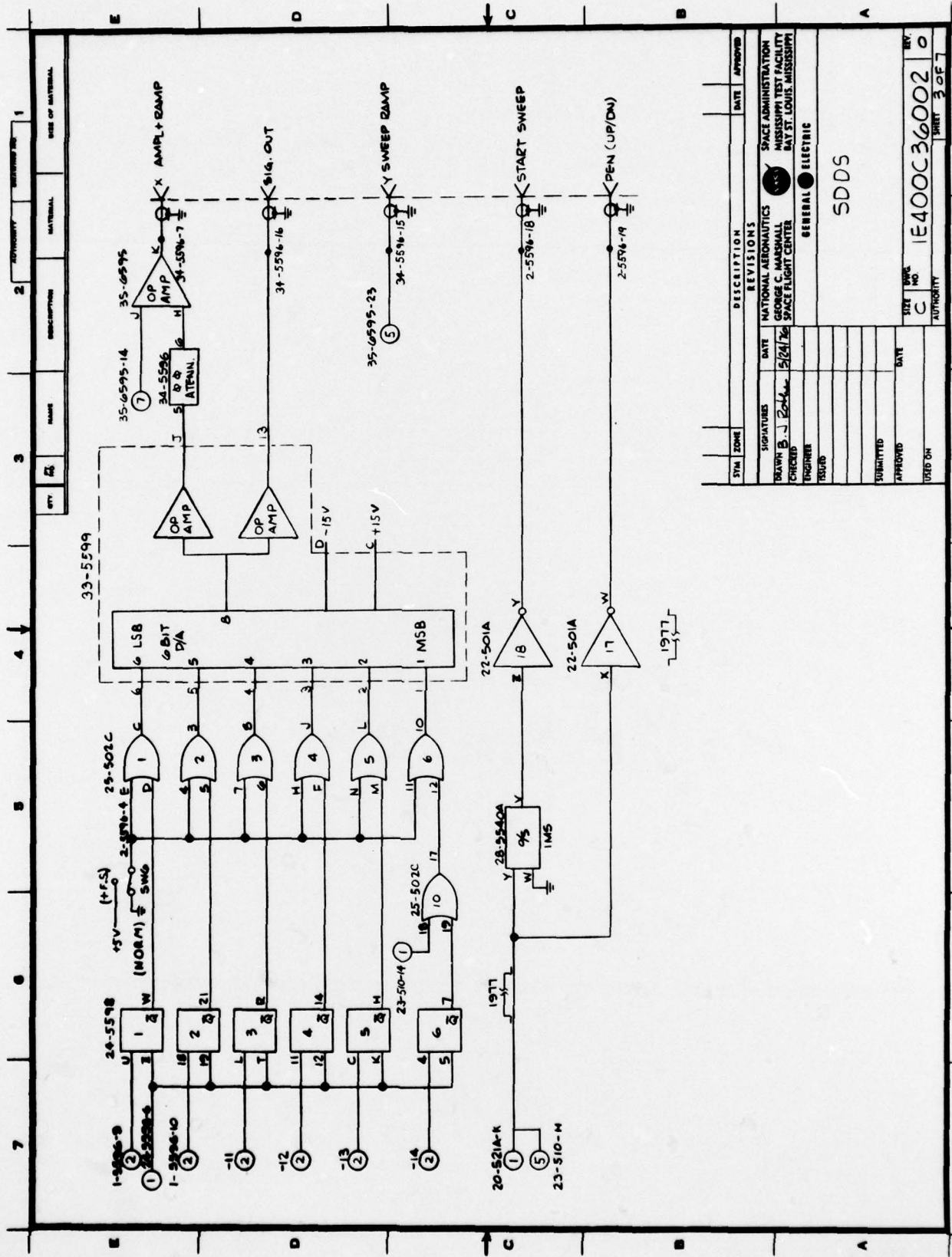

7 6 5 4 3 2 1

SYMBOL	ZONE	DESCRIPTION	DATE	APPROVED
1				
2				
3				
4				
5				
6				
7				

SYMBOL	ZONE	DESCRIPTION	DATE	APPROVED
1				
2				
3				
4				
5				
6				
7				

SYMBOL	ZONE	DESCRIPTION	DATE	APPROVED
1				
2				
3				
4				
5				
6				
7				

SYMBOL	ZONE	DESCRIPTION	DATE	APPROVED
1				
2				
3				
4				
5				
6				
7				

SYMBOL	ZONE	DESCRIPTION	DATE	APPROVED
1				
2				
3				
4				
5				
6				
7				

SYMBOL	ZONE	DESCRIPTION	DATE	APPROVED
1				
2				
3				
4				
5				
6				
7				

SYMBOL	ZONE	DESCRIPTION	DATE	APPROVED
1				
2				
3				
4				
5				
6				
7				

SYMBOL	ZONE	DESCRIPTION	DATE	APPROVED
1				
2				
3				
4				
5				
6				
7				

SYMBOL	ZONE	DESCRIPTION	DATE	APPROVED
1				
2				
3				
4				
5				
6				
7				

SYMBOL	ZONE	DESCRIPTION	DATE	APPROVED
1				
2				
3				
4				
5				
6				
7				

SYMBOL	ZONE	DESCRIPTION	DATE	APPROVED
1				
2				
3				
4				
5				
6				
7				

SYMBOL	ZONE	DESCRIPTION	DATE	APPROVED
1				
2				
3				
4				
5				
6				
7				

SYMBOL	ZONE	DESCRIPTION	DATE	APPROVED
1				
2				
3				
4				
5				
6				
7				

SYMBOL	ZONE	DESCRIPTION	DATE	APPROVED
1				
2				
3				
4				
5				
6				
7				

SYMBOL	ZONE	DESCRIPTION	DATE	APPROVED
1				
2				
3				
4				
5				
6				
7				

SYMBOL	ZONE	DESCRIPTION	DATE	APPROVED
1				
2				
3				
4				
5				
6				
7				

SYMBOL	ZONE	DESCRIPTION	DATE	APPROVED
1				
2				
3				
4				
5				
6				
7				

SYMBOL	ZONE	DESCRIPTION	DATE	APPROVED
1				
2				
3				
4				
5				
6				
7				

SYMBOL	ZONE	DESCRIPTION	DATE	APPROVED
1				
2				
3				
4				
5				
6				
7				

SYMBOL	ZONE	DESCRIPTION	DATE	APPROVED
1				
2				
3				
4				
5				
6				
7				

SYMBOL	ZONE	DESCRIPTION	DATE	APPROVED
1				
2				
3				
4				
5				
6				
7				

SYMBOL	ZONE	DESCRIPTION	DATE	APPROVED
1				
2				
3				
4				
5				
6				
7				

SYMBOL	ZONE	DESCRIPTION	DATE	APPROVED
1				
2				
3				
4				
5				
6				
7				

SYMBOL	ZONE	DESCRIPTION	DATE	APPROVED
1				
2				
3				
4				
5				
6				
7				

SYMBOL	ZONE	DESCRIPTION	DATE	APPROVED
1				
2				
3				
4				
5				
6				
7				

SYMBOL	ZONE	DESCRIPTION	DATE	APPROVED
1				
2				
3				
4				
5				
6				
7				

SYMBOL	ZONE	DESCRIPTION	DATE	APPROVED
1				
2				
3				
4				
5				
6				
7				

SYMBOL	ZONE	DESCRIPTION	DATE	APPROVED
1				
2				
3				
4				
5				
6				
7				

SYMBOL	ZONE	DESCRIPTION	DATE	APPROVED
1				
2				
3				
4				
5				
6				
7				

SYMBOL	ZONE	DESCRIPTION	DATE	APPROVED
1				
2				
3				
4				
5				
6				
7				

SIGNATURES		DATE		APPROVED																																									
DR. J. B.																																								
CHECKED																																								
ENGINEER																																								
IS/D/B																																								
<table border="1"> <thead> <tr> <th>SYMBOL</th> <th>ZONE</th> <th>DESCRIPTION</th> <th>DATE</th> <th>APPROVED</th> </tr> </thead> <tbody> <tr> <td>1</td> <td></td> <td></td> <td></td> <td></td> </tr> <tr> <td>2</td> <td></td> <td></td> <td></td> <td></td> </tr> <tr> <td>3</td> <td></td> <td></td> <td></td> <td></td> </tr> <tr> <td>4</td> <td></td> <td></td> <td></td> <td></td> </tr> <tr> <td>5</td> <td></td> <td></td> <td></td> <td></td> </tr> <tr> <td>6</td> <td></td> <td></td> <td></td> <td></td> </tr> <tr> <td>7</td> <td></td> <td></td> <td></td> <td></td> </tr> </tbody> </table>						SYMBOL	ZONE	DESCRIPTION	DATE	APPROVED	1					2					3					4					5					6					7				
SYMBOL	ZONE	DESCRIPTION	DATE	APPROVED																																									
1																																													
2																																													
3																																													
4																																													
5																																													
6																																													
7																																													
<table border="1"> <thead> <tr> <th>SYMBOL</th> <th>ZONE</th> <th>DESCRIPTION</th> <th>DATE</th> <th>APPROVED</th> </tr> </thead> <tbody> <tr> <td>1</td> <td></td> <td></td> <td></td> <td></td> </tr> <tr> <td>2</td> <td></td> <td></td> <td></td> <td></td> </tr> <tr> <td>3</td> <td></td> <td></td> <td></td> <td></td> </tr> <tr> <td>4</td> <td></td> <td></td> <td></td> <td></td> </tr> <tr> <td>5</td> <td></td> <td></td> <td></td> <td></td> </tr> <tr> <td>6</td> <td></td> <td></td> <td></td> <td></td> </tr> <tr> <td>7</td> <td></td> <td></td> <td></td> <td></td> </tr> </tbody> </table>						SYMBOL	ZONE	DESCRIPTION	DATE	APPROVED	1					2					3					4					5					6					7				
SYMBOL	ZONE	DESCRIPTION	DATE	APPROVED																																									
1																																													
2																																													
3																																													
4																																													
5																																													
6																																													
7																																													
<table border="1"> <thead> <tr> <th>SYMBOL</th> <th>ZONE</th> <th>DESCRIPTION</th> <th>DATE</th> <th>APPROVED</th> </tr> </thead> <tbody> <tr> <td>1</td> <td></td> <td></td> <td></td> <td></td> </tr> <tr> <td>2</td> <td></td> <td></td> <td></td> <td></td> </tr> <tr> <td>3</td> <td></td> <td></td> <td></td> <td></td> </tr> <tr> <td>4</td> <td></td> <td></td> <td></td> <td></td> </tr> <tr> <td>5</td> <td></td> <td></td> <td></td> <td></td> </tr> <tr> <td>6</td> <td></td> <td></td> <td></td> <td></td> </tr> <tr> <td>7</td> <td></td> <td></td> <td></td> <td></td> </tr> </tbody> </table>						SYMBOL	ZONE	DESCRIPTION	DATE	APPROVED	1					2					3					4					5					6					7				
SYMBOL	ZONE	DESCRIPTION	DATE	APPROVED																																									
1																																													
2																																													
3																																													
4																																													
5																																													
6																																													
7																																													
<table border="1"> <thead> <tr> <th>SYMBOL</th> <th>ZONE</th> <th>DESCRIPTION</th> <th>DATE</th> <th>APPROVED</th> </tr> </thead> <tbody> <tr> <td>1</td> <td></td> <td></td> <td></td> <td></td> </tr> <tr> <td>2</td> <td></td> <td></td> <td></td> <td></td> </tr> <tr> <td>3</td> <td></td> <td></td> <td></td> <td></td> </tr> <tr> <td>4</td> <td></td> <td></td> <td></td> <td></td> </tr> <tr> <td>5</td> <td></td> <td></td> <td></td> <td></td> </tr> <tr> <td>6</td> <td></td> <td></td> <td></td> <td></td> </tr> <tr> <td>7</td> <td></td> <td></td> <td></td> <td></td> </tr> </tbody> </table>						SYMBOL	ZONE	DESCRIPTION	DATE	APPROVED	1					2					3					4					5					6					7				
SYMBOL	ZONE	DESCRIPTION	DATE	APPROVED																																									
1																																													
2																																													
3																																													
4																																													
5																																													
6																																													
7																																													
<table border="1"> <thead> <tr> <th>SYMBOL</th> <th>ZONE</th> <th>DESCRIPTION</th> <th>DATE</th> <th>APPROVED</th> </tr> </thead> <tbody> <tr> <td>1</td> <td></td> <td></td> <td></td> <td></td> </tr> <tr> <td>2</td> <td></td> <td></td> <td></td> <td></td> </tr> <tr> <td>3</td> <td></td> <td></td> <td></td> <td></td> </tr> <tr> <td>4</td> <td></td> <td></td> <td></td> <td></td> </tr> <tr> <td>5</td> <td></</td></tr></tbody></table>						SYMBOL	ZONE	DESCRIPTION	DATE	APPROVED	1					2					3					4					5	</													
SYMBOL	ZONE	DESCRIPTION	DATE	APPROVED																																									
1																																													
2																																													
3																																													
4																																													
5	</																																												

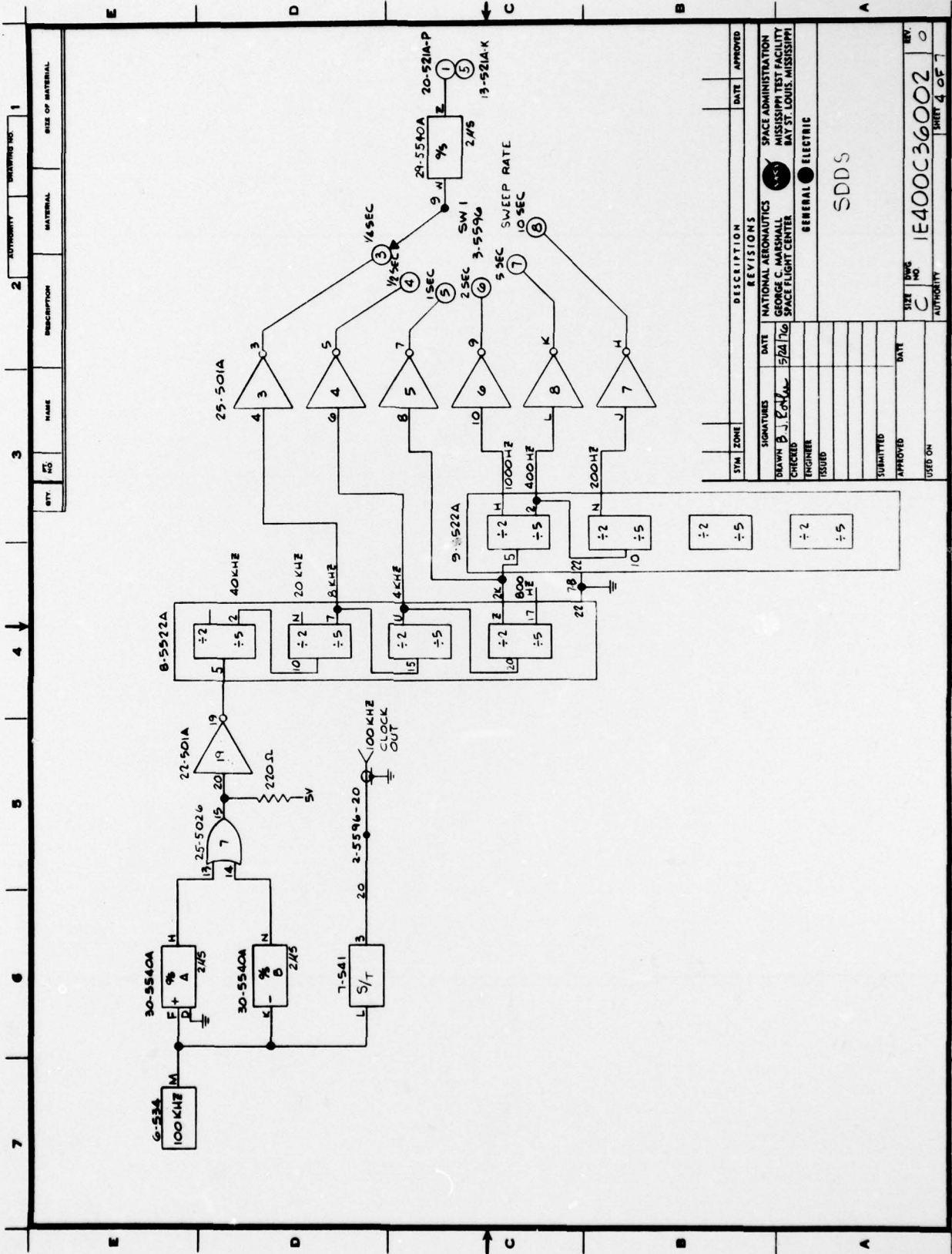

QTY	NO	NAME	DESCRIPTION	MATERIAL	QUANTITY NO.	SIZE OF MATERIAL
-----	----	------	-------------	----------	--------------	------------------

SYN	ZONE	DESCRIPTION	DATE	APPROVED
SIGNATURES				
DATE				
CHECKED				
ENGINEER				
ISSUED				
SUBMITTED				
APPROVED				
USED ON				
SIZE	NO	AUTHORITY		REV
C	1E400C36002			0
				1
				2
				3
				4
				5
				6
				7

DESCRIPTION

REVISIONS

NATIONAL AERONAUTICS
SPACE ADMINISTRATION
GEORGE C. MARSHALL
SPACE FLIGHT CENTER
MISSISSIPPI TEST FACILITY
BAT ST. LOUIS, MISSISSIPPI

GENERAL ELECTRIC

SDDS

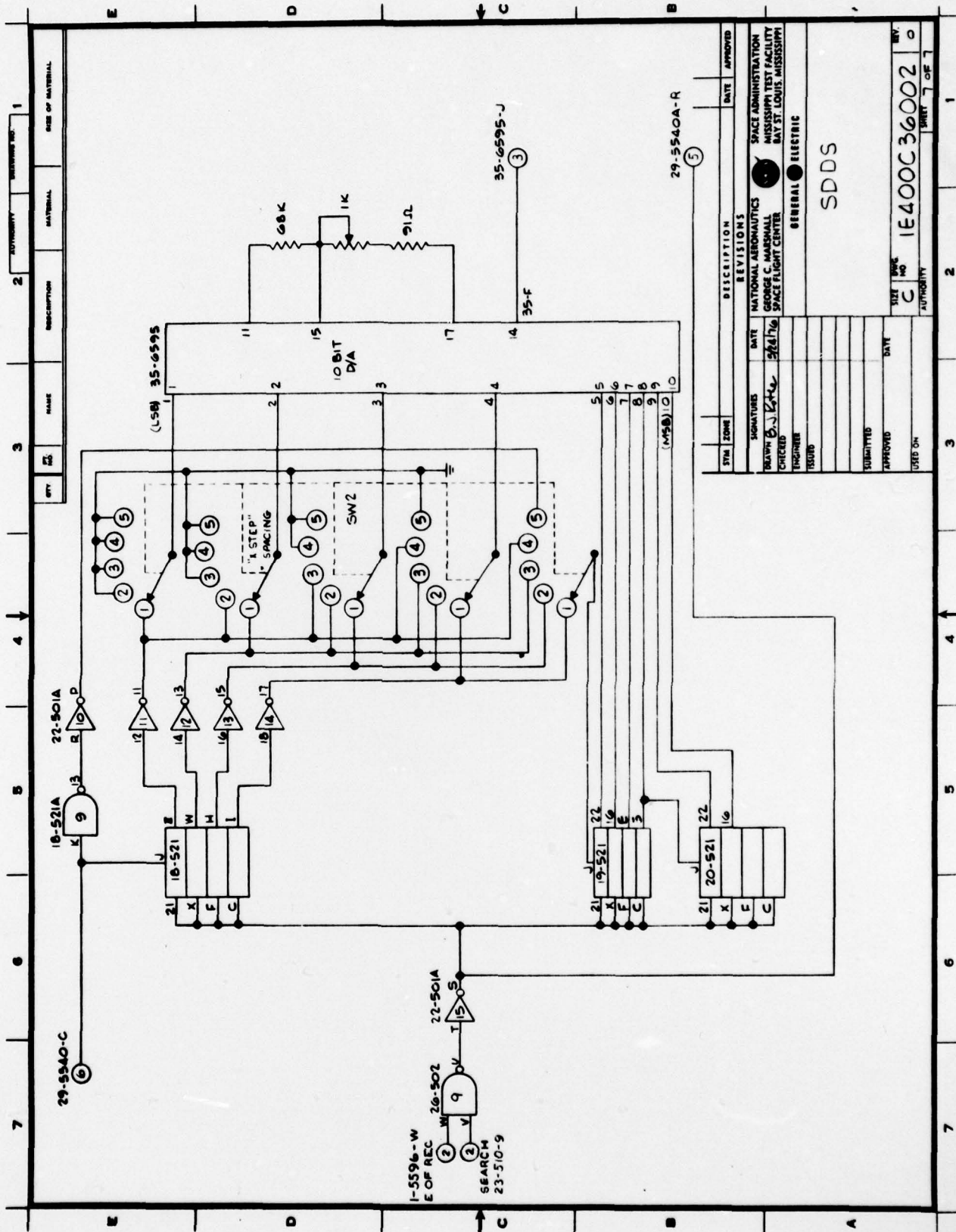

REV. NO.	DATE	DESCRIPTION	MATERIAL	QUANTITY	REVISION NO.
1					

SYMBOL		DESCRIPTION		DATE		APPROVED	
NATIONAL AERONAUTICS AND SPACE ADMINISTRATION GEORGE C. MARSHALL SPACE FLIGHT CENTER MISSISSIPPI TEST FACILITY BAY ST. LOUIS, MISSISSIPPI							
SIGNATURES DRAWN: [Signature] CHECKED: [Signature] ENGINEER: [Signature] TECHNICIAN: [Signature]				REVISIONS DATE: 5/21/76 BY: [Signature]			
SUBMITTED: [Date] APPROVED: [Date] USED ON: [Date]				GENERAL ELECTRIC SDDS			
SIZE: [Blank] NO.: C AUTHORITY:		PART NO.: 1E400C36002 REV.: 0		SHEET: 7 OF: 7		1	

UNCLASSIFIED

SECURITY CLASSIFICATION OF THIS PAGE (When Data Entered)

REPORT DOCUMENTATION PAGE		READ INSTRUCTIONS BEFORE COMPLETING FORM
1. REPORT NUMBER NORDA Technical Note 15	2. GOVT ACCESSION NO.	3. RECIPIENT'S CATALOG NUMBER
4. TITLE (and Subtitle) Marine Seismic Display Enhancement Program Final Report Volume III Users Handbooks Seismic Data Acquisition System (SDAS)		5. TYPE OF REPORT & PERIOD COVERED Final
		6. PERFORMING ORG. REPORT NUMBER
7. AUTHOR Seismic Data Display System (SDDS) Bruce E. Eckstein and Martin G. Fagot (editors)		8. CONTRACT OR GRANT NUMBER(s)
9. PERFORMING ORGANIZATION NAME AND ADDRESS Naval Ocean Research and Development Activity Naval Oceanographic Laboratory NSTL Station, MS 39529		10. PROGRAM ELEMENT, PROJECT, TASK AREA & WORK UNIT NUMBERS 63704N/0118/300
11. CONTROLLING OFFICE NAME AND ADDRESS Naval Ocean Research and Development Activity Ocean Exploratory Development Office NSTL Station, MS 39529		12. REPORT DATE
		13. NUMBER OF PAGES
14. MONITORING AGENCY NAME & ADDRESS (if different from Controlling Office)		15. SECURITY CLASS. (of this report) Unclassified
		15a. DECLASSIFICATION/DOWNGRADING SCHEDULE
16. DISTRIBUTION STATEMENT (of this Report) Approved for public release; distribution unlimited		
17. DISTRIBUTION STATEMENT (of the abstract entered in Block 20, if different from Report)		
18. SUPPLEMENTARY NOTES This report is Volume III of a three volume final report series on the Marine Seismic Display Enhancement Program.		
19. KEY WORDS (Continue on reverse side if necessary and identify by block number) Marine seismic system, data acquisition, multi-channel digitizing, data display		
20. ABSTRACT (Continue on reverse side if necessary and identify by block number) This report describes, in a users handbook format, the operation of hardware systems used to acquire and playback seismic profiling data. The Seismic Data Acquisition System digitizes 1 to 16 channels of analog seismic information and records this data on magnetic tape. This digital data has a maximum dynamic range of 72 dB and maximum sample rate of 10 kHz divided by the number of channels. Record lengths up to 15 seconds with a maximum record delay, before digitizing, of 15 seconds may be selected.		

DD FORM 1473
1 JAN 73

EDITION OF 1 NOV 65 IS OBSOLETE
S/N 0102-014-6601

UNCLASSIFIED

SECURITY CLASSIFICATION OF THIS PAGE (When Data Entered)

CONT →

UNCLASSIFIED

SECURITY CLASSIFICATION OF THIS PAGE(When Data Entered)

plus or minus

→ Maximum signal level for the system is ± 10 volts. The Seismic Data Display System converts a 36 dB dynamic range digital signal to an analog signal having a maximum level of ± 10 volts. The digital information displayed will contain 2000 data points per record. The system has the capability to display seismic data on a line scan intensity modulated recorder, an X-Y recorder, or a high speed fiber optic recorder. Included as appendices are schematic diagrams of the acquisition and display hardware.

UNCLASSIFIED

SECURITY CLASSIFICATION OF THIS PAGE(When Data Entered)