

(12) LEVEL III

AD-E 300648

DNA 4833T

ADA 079942

**SOIL STRAIN MEASUREMENTS ON
MISERS BLUFF - PHASE II**

Electromechanical Systems of New Mexico, Inc.
P.O. Box 11730
Albuquerque, New Mexico 87192

30 April 1979

Topical Report for Period 1 May 1978-30 April 1979

CONTRACT No. DNA 001-78-C-0260

APPROVED FOR PUBLIC RELEASE;
DISTRIBUTION UNLIMITED.

DDC FILE COPY

THIS WORK SPONSORED BY THE DEFENSE NUCLEAR AGENCY
UNDER RDT&E RMSS CODE B344079462 J11AAXSX35257 H2590D.

Prepared for
Director
DEFENSE NUCLEAR AGENCY
Washington, D. C. 20305

DDC
RECEIVED
JAN 29 1980
B

80 1 - 9 059

Destroy this report when it is no longer
needed. Do not return to sender.

PLEASE NOTIFY THE DEFENSE NUCLEAR AGENCY,
ATTN: STTI, WASHINGTON, D.C. 20305, IF
YOUR ADDRESS IS INCORRECT, IF YOU WISH TO
BE DELETED FROM THE DISTRIBUTION LIST, OR
IF THE ADDRESSEE IS NO LONGER EMPLOYED BY
YOUR ORGANIZATION.



UNCLASSIFIED

18 DNA, FBI E

SECURITY CLASSIFICATION OF THIS PAGE (When Data Entered)

19 REPORT DOCUMENTATION PAGE		READ INSTRUCTIONS BEFORE COMPLETING FORM	
1. REPORT NUMBER DNA 4833T	2. GOVT ACCESSION NO. AD-E300 0481	3. RECIPIENT'S CATALOG NUMBER	
4. TITLE (and Subtitle) SOIL STRAIN MEASUREMENTS ON MISERS BLUFF • PHASE II.		9	5. TYPE OF REPORT & PERIOD COVERED Topical Report for Period - 1 May 78 - 30 Apr 79
7. AUTHOR(s) Dr R. A. Shunk		14	6. PERFORMING ORG. REPORT NUMBER ESI-79-001-TR
9. PERFORMING ORGANIZATION NAME AND ADDRESS Electromechanical Systems of New Mexico, Inc. P.O. Box 11730 Albuquerque, New Mexico 87192		15	8. CONTRACT OR GRANT NUMBER(s) DNA 001-78-C-0260
11. CONTROLLING OFFICE NAME AND ADDRESS Director Defense Nuclear Agency Washington, D.C. 20305		11	10. PROGRAM ELEMENT, PROJECT, TASK AREA & WORK UNIT NUMBERS Subtask J11AAXSX352-57
14. MONITORING AGENCY NAME & ADDRESS (if different from Controlling Office) 1243		11	12. REPORT DATE 30 Apr 1979
			13. NUMBER OF PAGES 44
			15. SECURITY CLASS (of this report) UNCLASSIFIED
			15a. DECLASSIFICATION/DOWNGRADING SCHEDULE
16. DISTRIBUTION STATEMENT (of this Report) Approved for public release; distribution unlimited.			
17. DISTRIBUTION STATEMENT (of the abstract entered in Block 20, if different from Report)			
18. SUPPLEMENTARY NOTES This work sponsored by the Defense Nuclear Agency under RDT&E RMSS Code B344079462 J11AAXSX35257 H2590D.			
19. KEY WORDS (Continue on reverse side if necessary and identify by block number) Soil Strain Dynamic Soil Strain Strain Gage High Explosives			
20. ABSTRACT (Continue on reverse side if necessary and identify by block number) Soil strain measurements were made on the MISERS BLUFF - Phase II tests. The first test, a 109 metric ton ANFO explosion, indicated that the tubular, telescoping strain gage with large end plates and a DC LVDT sensing element should be adequate to measure strains on the second test which was the detonation of six 109 metric ton ANFO charges on the corners of a 100 m hexagon. The strains observed on the second event were much larger than on the first event. Three locations were instrumental to 1.6 m in depth for vertical			

DD FORM 1 JAN 73 1473 EDITION OF 1 NOV 65 IS OBSOLETE

UNCLASSIFIED

SECURITY CLASSIFICATION OF THIS PAGE (When Data Entered)

392 798

14

UNCLASSIFIED

SECURITY CLASSIFICATION OF THIS PAGE(When Data Entered)

20 ABSTRACT (Continued)

strain, two halfway between charges on opposite sides of the array and one 6 m from the array center. The strains were initially compressive due to air shock loading and then extensional during the negative phase. Extensional strains greater than 50% were observed at the 6 m location down to a depth of 0.9 m. The air shock loading at the locations between charges was not the same, nor were the soils identical. Strains of -12% to +30% were typical at near surface locations. The final or residual strain measured on recovery was usually compressive except at one location where the soil was very powdery.

A

UNCLASSIFIED

SECURITY CLASSIFICATION OF THIS PAGE(When Data Entered)

SUMMARY

The objective of measuring the soil strain at select places in the test bed on the MISERS BLUFF - Phase II - Test 2 was partially met. Some gage failures due to very high acceleration and an unexpectedly large positive strain near the center of the test bed above 1.2 m in depth which were greater than 50% reduced the expected quantitative data yield. The material here did not behave like that in Frenchman's Flat^{1,2,3} as no significant overexpansion is observed in that strain data as was observed on Test 1 and 2.

A strain gage capable of measuring at least 60% strain is apparently required for the type of measurement attempted here. Under the observed conditions of high peak accelerations, incompetent soil and rapidly varying soil density with time and with local shearing and rotation present during the motion, a unique gage design is required if more strain measurements are to be made on explosive simulation tests of the nature of MISERS BLUFF - Phase II - Test 2.

ACCESSION for	
NTIS	White Section <input checked="" type="checkbox"/>
DDC	Buff Section <input type="checkbox"/>
UNANNOUNCED	<input type="checkbox"/>
JUSTIFICATION _____	
BY _____	
DISTRIBUTION/AVAILABILITY CODES	
Dist.	AVAIL. and/or SPECIAL
A	

PREFACE

This work was done under the auspices of the Defense Nuclear Agency (DNA), Contract DNA001-78-C-0260, RDT&E Code B3440 79462 J11AAXSX35257 H2590D.

Soil strain measurements down to 1.5 m in depth were made on the MISERS BLUFF - Phase II Tests 1 and 2 in addition to the traditional measurements of soil stress, acceleration, particle velocity and air shock pressure. The soil strain measurements indicated an initial compression due to air shock loading on the surface followed by a significant overexpansion of the soil during the negative phase of the air shock loading.

The support of Lt. Col. Robert Bestgen, Mr. Tom Kennedy and Capt. Robert DeRaad of DNA is greatly appreciated. The Waterways Experiment Station (WES) personnel that fielded these experiments and performed the installation of gages and recording of the gage outputs were working under Mr. J. D. Day and Mr. Don Murrell. My thanks to them and to Mr. John Stout, Mr. Jim Pickens and Mr. Phil Jones and many others from WES for their excellent work under the dirty, hot, miserable field conditions at Planet Ranch.

TABLE OF CONTENTS

<u>Section</u>		<u>Page</u>
I	INTRODUCTION	7
II	SOIL STRAIN GAGE DEVELOPMENT ON TEST 1	9
III	RESULTS OF TEST 1	16
IV	RESULTS OF TEST 2	22
	REFERENCES	38

LIST OF ILLUSTRATIONS

<u>Figure</u>		<u>Page</u>
1	Location of Strain Measurements on MISERS BLUFF - Phase II	8
2	Sketch of LVDT Gage	10
3	The Mutual Inductance Gage After Partial Excavation After Test 1	11
4	One Spool Gage is in Place and the Dummy Gage on the Right is used to Make a Pattern for the Active Spool Gage	13
5	Spool Gage after Partial Excavation Following Test 1	14
6	109 Metric Ton ANFO Stack for Test 1	15
7	Stress Strain and Overpressure Data at 50 M and 100 M on Test 1	17
8	Diaphragm Stress Gages Partially Uncovered for Measuring Vertical and Horizontal Stress	20
9	Two Strain Gages at 60 ⁰ During Recovery. The Tilt is Toward 180 ⁰	21
10	Air Blast Wave Form at 180 ⁰ and 6 M from Center Over Strain Gage Emplacement	23
11	Strain Records from Gages at 60 ⁰ and 84 M from Array Center	24
12	A Typical Accelerometer Record with its Integral	26
13	The Strain Gages at 240 ⁰ , 84 M During Recovery	27
14	Strain Records from Gages at 240 ⁰ , 84 M	29
15	Overextended Strain Gage at 180 ⁰ , 6 M	31
16	Appearance of Gages at 1.2 and 1.5 M During Recovery	32
17	Strain Records from Gages at 180 ⁰ - 6 M	33
18	Typical Accelerometer Record with its Integral from 180 ⁰ - 6 M	34

LIST OF ILLUSTRATIONS (Continued)

<u>Figure</u>		<u>Page</u>
19	Strain Gage Calibration Curve	36
20	Unfolded Strain from 180 - 6 M	37

SECTION I
INTRODUCTION

Measurements of the strain in soil on shock and blast experiments have been made in the past, notably on early atmospheric nuclear explosions^{1,2,3}. However, this measurement has usually been avoided on tests where a high explosives detonation was used to simulate the air and ground shock from a nuclear weapons detonation until the DNA test series MISERS BLUFF - Phase II was executed in August and September of 1978 at the Planet Ranch Site on the Bill Williams River in Arizona. Two tests were performed. One was a single 109 metric ton detonation of a stack of ammonium nitrate and fuel oil mixture (ANFO) and the other was the explosion of an array of six 109 metric ton ANFO charges placed on the corners of a hexagon 100 m on a side. These charges were detonated simultaneously.

The strain to be measured would be induced in the soil by the air and ground shock from the six explosive detonations. Soil strain, soil stress and acceleration were measured near three locations; one 6 m from the center and two between charges on opposite sides of the array, Figure 1.

The soil at this site was not typical of any of the soils under past high explosive experiments. The soil had a very high void ratio, about 47%, for the top 1.2 - 1.6 m. It was an aeolian and alluvial deposit of a fine silt with very low strength. This complicated gage placement and gage design.

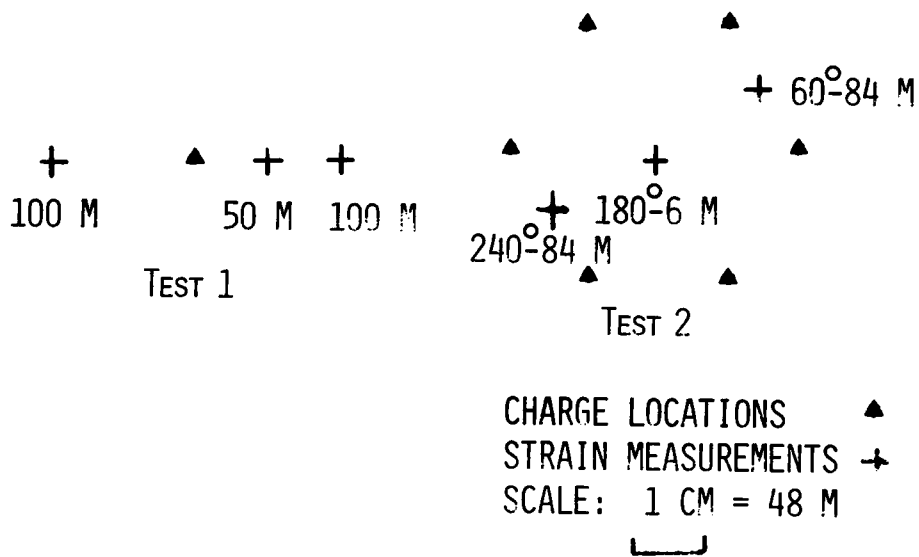
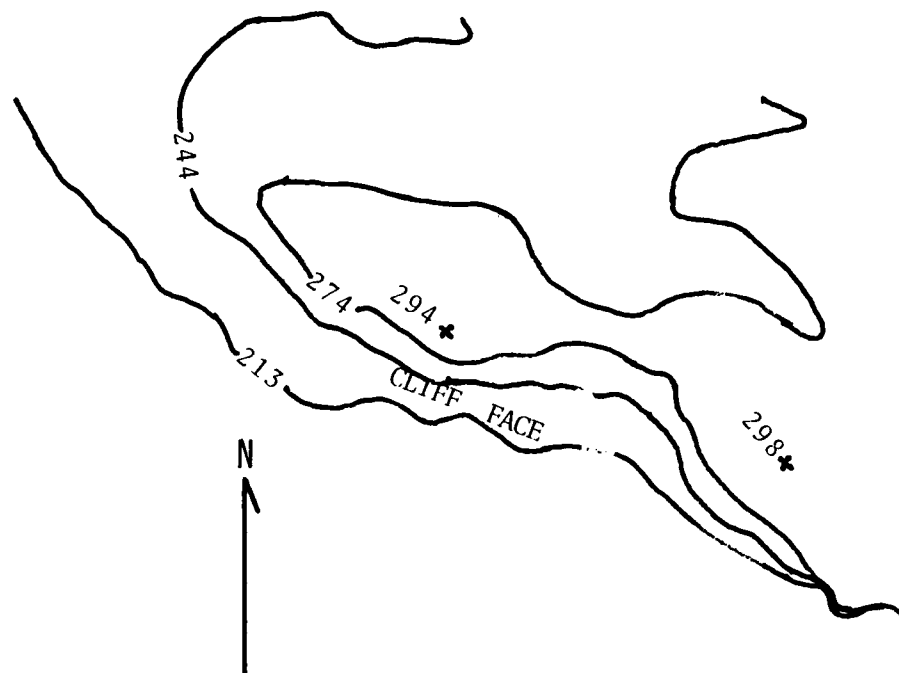

FIGURE 1 - LOCATION OF STRAIN MEASUREMENTS ON MISERS BLUFF - PHASE II.

SECTION II

SOIL STRAIN GAGE DEVELOPMENT ON TEST 1

To be sure that there was a reasonable probability of success, some initial gage development was done on Test 1 to identify a system for use on the six charge event. A single ANFO charge weighing 1.09×10^2 metric tons was detonated near the site of the six charge event. The general layout is shown in Figure 1. Three types of gages were fielded. One was a standard 3 kHz carrier system operated with a linear variable transformer (LVDT) in a spool gage (Figure 2); another was a so-called DC LVDT which has the signal conditioning electronics with the gage so a DC voltage applied to the gage is all that is necessary for signal generation; the third was a gage developed by IITRI⁴ which operated on the change in mutual inductance between two coils.

Outwardly, the first two look identical. The LVDT body is held in the tube with a thin layer of ridged epoxy. This tube telescopes into a second tube. Both tubes have relatively large end plates fastened to them to lock them into the soil. The maximum linear gage range is about 23%. The core of the LVDT is mounted on the end of a threaded rod fastened to the end plate as shown in Figure 2 and adjusted to make the gage approximately 30 cm in length when the output is at null. Cable protection is accomplished by running the power and output leads through a short piece of 0.32 cm pipe in the end of the gage tube. A piece of heavy Tygon tubing about 1 m long is slipped over the pipe and the cable run through it. A splice is made at the end of the tubing to a four conductor cable. Waterproofing of the splice, cable and tubing keeps water from entering the gage through the cable. Thin plastic tubing is slipped over the gage body before emplacement and securely fastened to the bosses at either end of the gage. The gage is then completely waterproofed.

The third type of gage is shown in Figure 3 after it was partially uncovered after the test. The coils are encapsulated in plastic and are 10 cm in diameter. They are placed 30 cm apart in the soil. One coil

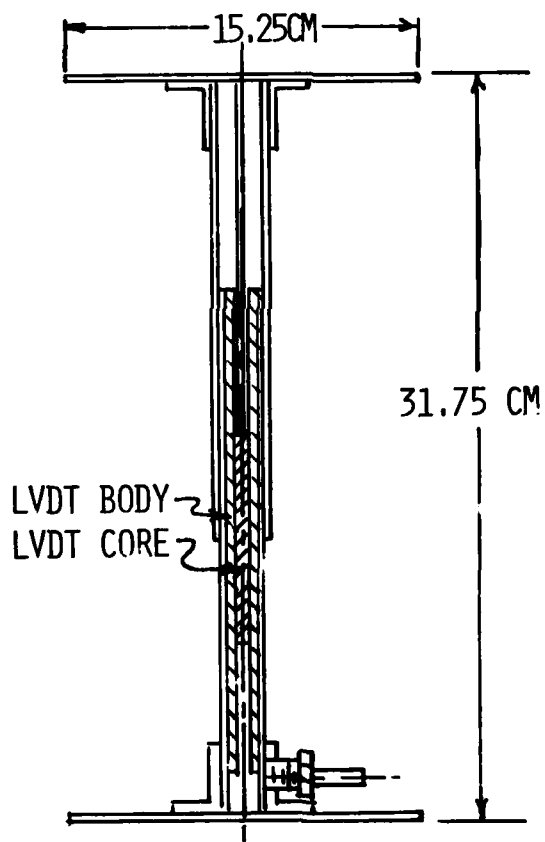

FIGURE 2 - SKETCH OF LVDT GAGE.

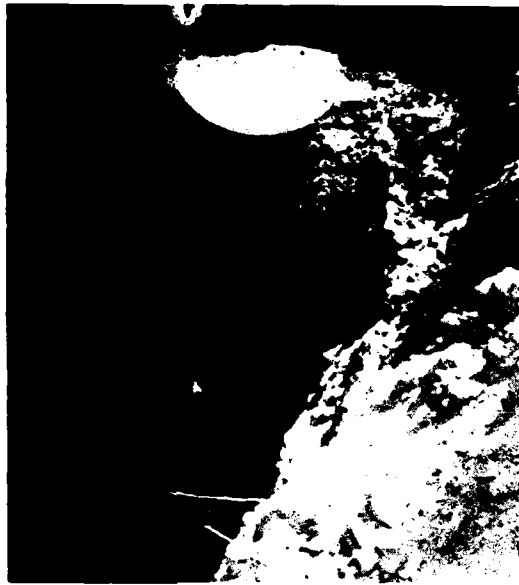

FIGURE 3 - THE MUTUAL INDUCTANCE GAGE AFTER
PARTIAL EXCAVATION AFTER TEST 1.

is driven at 20 kHz by an oscillator and the other coil is connected to a high gain tuned amplifier. The output is demodulated and filtered to remove the carrier and recorded. All signals were recorded on magnetic tape in a remote trailer operated by the Waterways Experiment Station.

The gages were located at three places in the test bed as shown in Figure 1. All gages were oriented to measure vertical strain. The 3 kHz LVDT and DC LVDT spool gages were placed 100 m west of the charge at 30 cm depth to gage center. 50 m east of the charge, one mutual inductance gage was placed at 30 cm and DC LVDT spool gages were placed at 30 cm at 45 cm depth. 100 m east of the charge DC LVDT spool gages were placed at 30 cm and 45 cm depth.

Gage emplacement was accomplished by cutting a trench into the test bed. The material was free-standing and did support a vertical wall. Emplacement is done by chipping material from the wall until half of a dummy gage fits into the wall as shown in Figure 4. Cables are run down to the bottom of the trench and then into another narrow trench which carries the cables back to a junction box, thence to the recording trailer. The excavated material is then moistened and hand tamped back into the trench. The porosity and density are maintained as closely as possible to in situ conditions. On recovery of gages, no differential end plate distortion was noted as seen in Figure 5, so it was assumed that the placement process had been satisfactory.

The charge is shown in Figure 6. The peak predicted overpressure at 50 m is 1.93 mega-pascals (MPa) and 0.29 MPa at 100 m. These values turned out to be quite close to the measured overpressure.

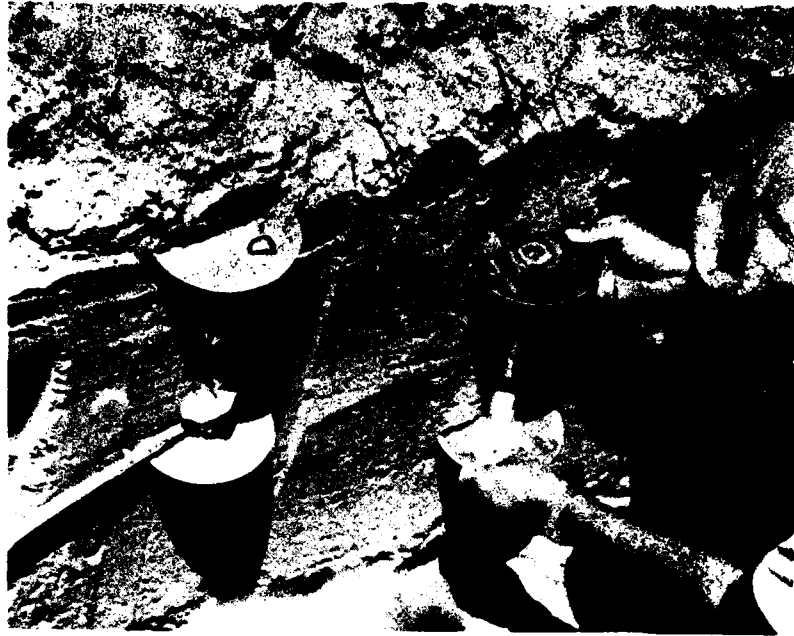

FIGURE 4 - ONE SPOOL GAGE IS IN PLACE AND THE DUMMY GAGE ON THE RIGHT IS USED TO MAKE A PATTERN FOR THE ACTIVE SPOOL GAGE.



FIGURE 5 - SPOOL GAGE AFTER PARTIAL EXCAVATION
FOLLOWING TEST 1.



FIGURE 6 - 109 METRIC TON ANFO
STACK FOR TEST 1.

SECTION III

RESULTS OF TEST 1

The data recovered from the first test are shown in Figure 7 for the locations at 50 m and 100 m east (90^0). The shock wave pressure vs time is also shown with one channel amplified so the positive peak is clipped but the negative phase structure is clear. There is a noise spike clearly visible which is not associated with the pressure, however, and should be ignored. The measured positive phase and negative phase durations are 40 msec and 0.5 sec respectively at 50 m. At 100 m they are 60 msec and 0.62 sec. The peak negative phase pressure at 50 m and 100 m is 0.045 MPa and 0.025 MPa below atmospheric, respectively.

The strain data that are recorded from the various gages require some interpretation. At 50 m the soil compression during the positive phase of the air blast is apparent. Following the compression is an overexpansion which is caused by the negative phase. However, during this time there are relatively sudden recompressions of the soil which are not associated with the air blast.

The signal appearing on the stress and strain records in Figure 7 near 500 ms is not on the air pressure signal, therefore its source is not related to the explosive performance. The stress signal at 9 m depth - 100 m range arrives at 0.46 sec but arrives at the 50 m station at 0.52 sec with an apparent velocity of 883 m/s. It appears to arrive from a depth which can be seen by comparing the stress at 9 m depth with the strain signals at 0.5 m and 0.3 m respectively at 100 m range in Figure 7. This indicates a compressive wave traveling in a deeper medium which is going toward the detonation and moving up through the test bed. The origin of such a wave could be a reflection from a discontinuity in the test bed which would reflect a compression. The rock of the cliff face to the east extends down almost vertically on the east side of the test bed which could explain such a wave reflection. The distance from the charge location to the foot of the cliff is 400 m and the sound speed in the lower material is 1672 m/s. The round trip travel time is 0.48 sec

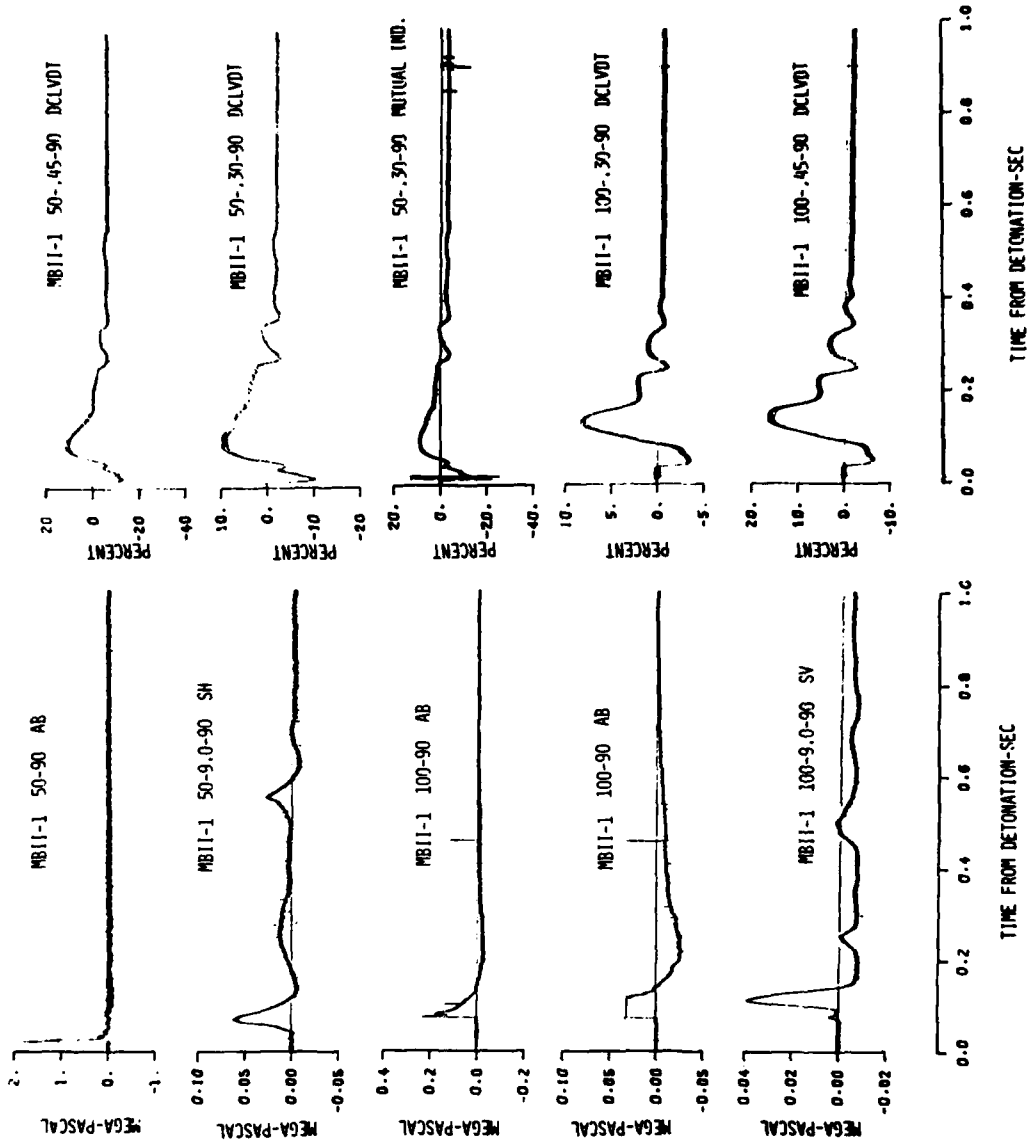

FIGURE 7 - STRAIN STRESS AND OVERPRESSURE DATA AT 50 M AND 100 M ON TEST J.

which is close to the times noted here. The propagation of the ground shock through the lower sound speed material above the water table could easily account for a 20 ms increase in time. Another explanation would be to consider a spalling process where the material near the charge is raised higher than the material further from the charge. On fall back, the material further from the charge would recompact sooner than the material near the charge creating a wave moving toward the charge. This means the effect near the charge should be larger if the change in momentum is considered. The material near the charge falls further than the material farther out and, therefore, gains a higher velocity when recompactation occurs. Looking at the stress and strain records at 50 and 100 m at 9 m depth indicates that the above postulate could also be true.

There is an additional signal present on the stress and strain records at about 0.7 sec which cross correlate but its origin is obscure at this time.

The data showed that the carrier operated LVDT with the signal conditioner about one hundred meters away clipped the signal peak due to insufficient range. The DC LVDT's appeared to present clean data while the mutual inductance gage had a noisy output possibly related to straining the relatively fragile wires going to the coils. There was also an operational problem when placing the mutual inductance gage electronics in the field which is related to temperature changes. The circuit is very sensitive to temperature changes and it was known before the test that the air temperature on the test bed at test time would be between 41⁰C and 47⁰C. As the electronics has to be within a few hundred meters of the gage, the electronics was put in an insulated box which was buried in the ground with ice put in the box to stabilize the temperature. The circuits were balanced a few hours before the execution of the test and worked well.

The mutual inductance gage system, while capable of measuring the largest strains, was not immediately available in the numbers required for the second event and the cable fragility problem at the coil had not been solved, so a decision was made to use the DC LVDT gage exclusively.

At the three locations instrumented for strain on the six charge event, one was between charges at 240° and 84 m from the array center (see Figure 1) where five spool strain gages were placed at depths of 0.3 m, 0.45 m, 0.6 m, 0.9 m and 1.2 m; one on the opposite side of the array (60° and 84 m) where five spool gages were placed at depths of 0.3 m, 0.45 m, 0.6 m, 0.9 m and 1.2 m and one at 180° , 6 m from the center where six spool gages were placed at 0.3 m, 0.45 m, 0.6 m, 0.9 m, 1.2 m and 1.5 m. Stress gages and accelerometers were also placed at many of the same depths in the trenches near the strain gages. The stress gage is a thin diaphragm gage⁵ and two are shown in Figure 8 in place as they were uncovered post test.

The material at the three locations was very incompetent. The gage placement in the trench at 60° was very difficult because the material was very fine and unconsolidated and the trench wall sloughed off continually. As a result, the gages in this pit were placed in a sloping face and the material hand tamped around them. Two of the upper gages are shown in Figure 9 on recovery. As a result of this experience, the ground was moistened to strengthen the soil by letting water run into a shallow trench over the remaining two emplacement sites for several days. The resulting trenches then maintained a vertical wall for gage placement.

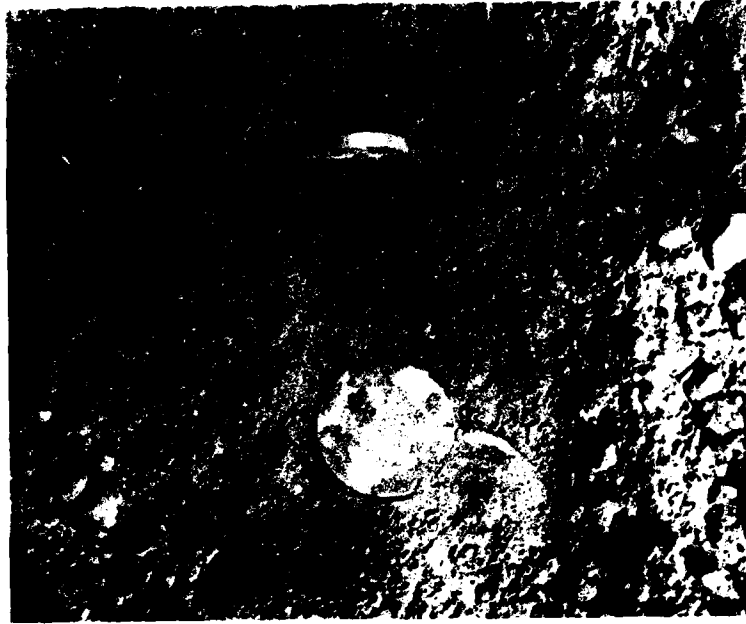

FIGURE 8 - DIAPHRAGM STRESS GAGES PARTIALLY UNCOVERED FOR MEASURING VERTICAL AND HORIZONTAL STRESS.



FIGURE 9 - TWO STRAIN GAGES AT 60°
DURING RECOVERY. THE TILT IS
TOWARD 180° .

SECTION IV
RESULTS OF TEST 2

When the charges were detonated, the predicted pressure between charges was 12.4 MPa. The incident air shock wave is traveling at over Mach 4 while the speed of sound in the soil is comparable to air, so the wave incident on the gages should be primarily vertical in the gage arrays between charges. The measured peak overpressure at 60° was 10.4 MPa and 7.2 MPa at 240° so the charges apparently did not form identical shock waves at identical times. The positive phase duration was about 30 msec and the negative phase duration is unknown. The gages near the center were located at 180° and 6 m from the array center. The air shock had a distinctive three shock form shown in Figure 10. The positive phase impulse is over twice that at the other locations. The negative phase duration is about 0.25 sec and has a peak value about 0.022 MPa below atmospheric. The environment at all locations is considerably more severe than on the first test.

At the sixty degree location, the peak accelerations measured near the gages ranged from -8600 g at 0.3 m to ±670 g at 1.2 m depth. The strain data from the top two gages indicate severe damage to the LVDT proper because of signal shape and timing. The third gage down appears to have slipped the LVDT core upward at the onset of the acceleration. The gage at 0.9 m appears normal and the gage at 1.2 m has slipped the LVDT body upward in the tube as indicated by the base line. Plots of these gage outputs are shown in Figure 11.

On recovery, the gages lengths were measured and compared to pre-test lengths to obtain permanent strain. These are tabulated in Table 1. The gage at 0.9 was disturbed when the excavation caved in and could not be measured. The indication from the record is 6% strain which seems reasonable.

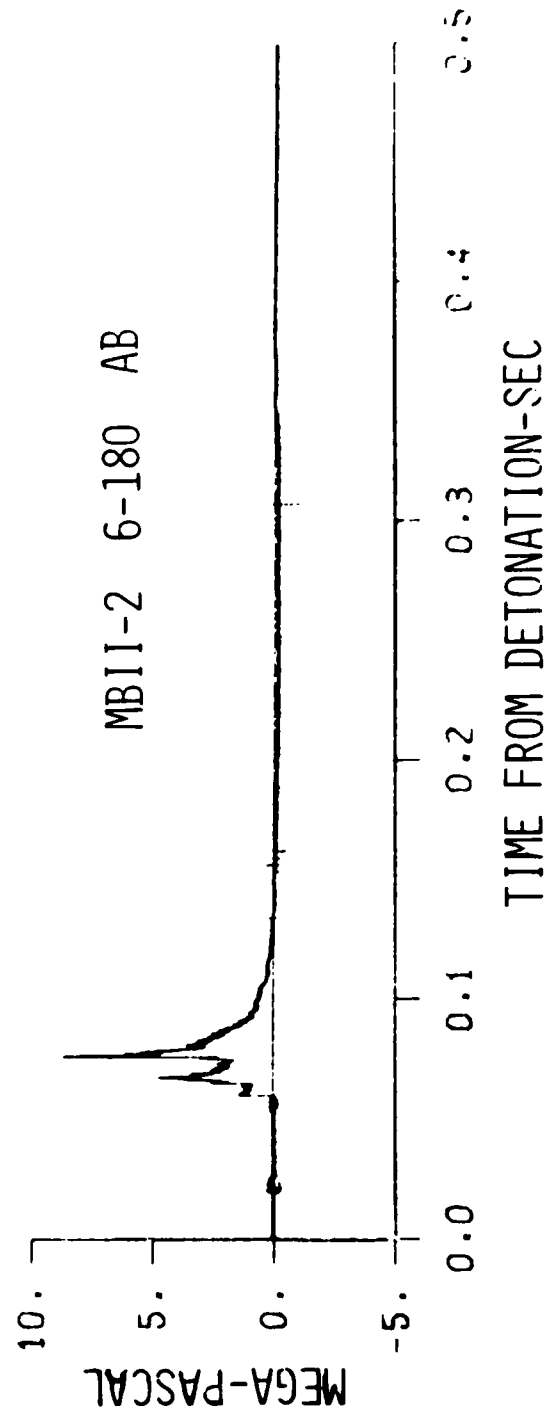

FIGURE 10 - AIR BLAST WAVE FORM AT 180° AND 6 M FROM CENTER OVER STRAIN GAGE EMPLACEMENT.

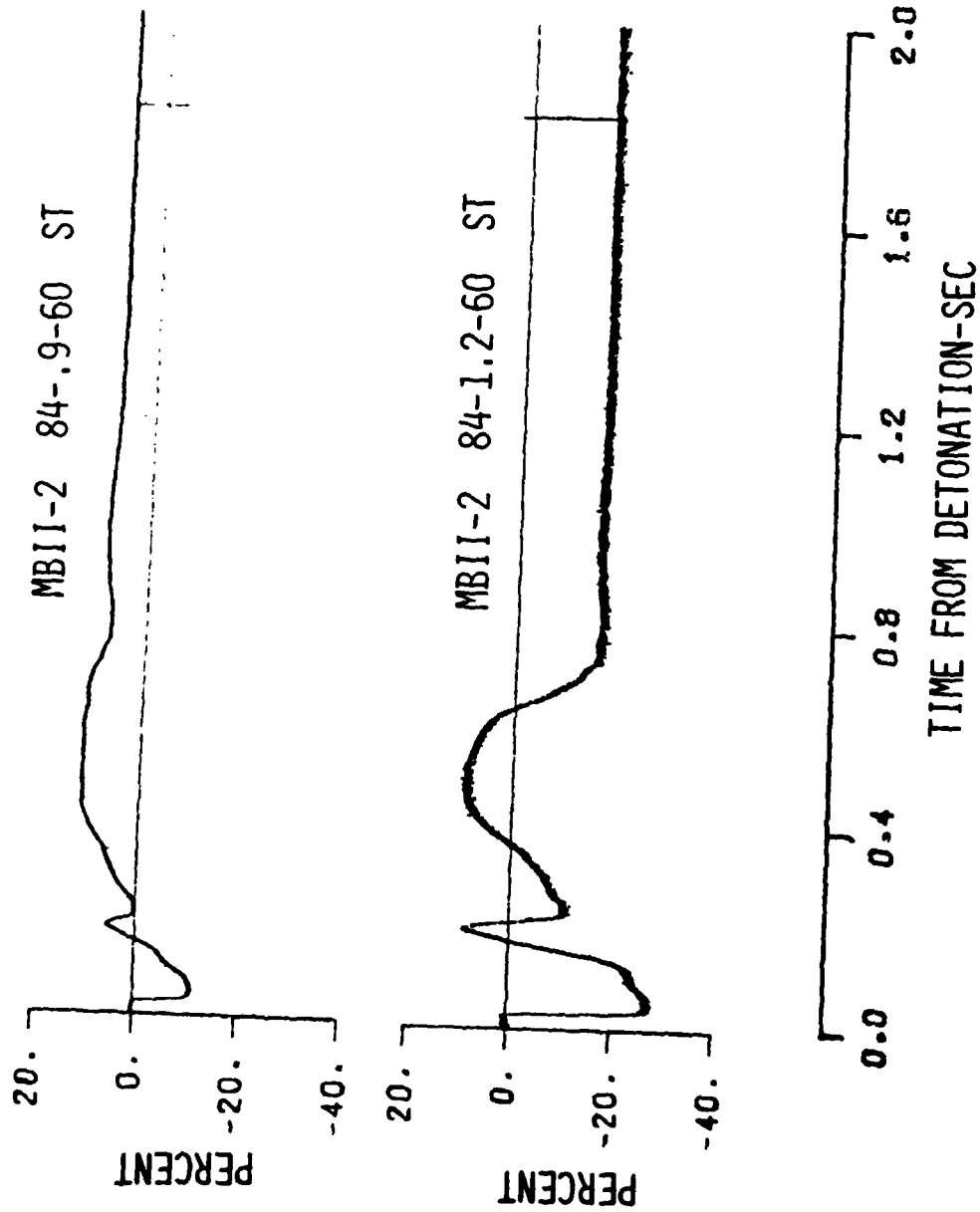

FIGURE 11 - STRAIN RECORDS FROM GAGES AT 60° AND 84 M FROM ARRAY CENTER.

Table 1. Post test strains at 60°, 84 m from array center

<u>Depth m</u>	<u>Post Test Strain - %</u>
.3	-4
.45	6
.6	11
1.2	4

The slipping of the gage body at 1.2 m produced an interesting feature. The base line can be assumed to represent a LVDT body motion of 16% of the gage length plus the post test strain of 4% or a 20% total movement of the LVDT body. The original gage length was 28.7 cm so this means the core moved some 5.7 cm. Post test examination of the gage revealed a body motion. The result is that a peak extensional strain of about 30% occurred at about 0.2 sec and 0.45 sec. The peak compressional strain of -12% occurred at around 50 msec.

A second pressure wave appears in the rarefaction at about 0.12 sec which has a very small amplitude compared to the incident overpressure. However, it has a very strong effect on the strain and is the source of the second down going strain signal. It is propagating through the test bed with an average velocity of 14.3 m/sec \pm 2 m/sec while the initial wave travels at about 130 m/sec \pm 12 m/sec, an 8:1 ratio of velocities for the initial compression and a compression wave traveling through an expanding material. A typical accelerometer record and its integral are shown in Figure 12 to illustrate what is happening. Caution should be used with these data because it is not clear that the gage canister and soil are moving together while the soil is overexpanded.

At the two hundred and forty degree location on the opposite side of the array, soil stress gages, accelerometers and the soil strain gages were placed in the same trench. The material here was more like that encountered on the first test and gage placement and recovery was relatively straightforward. The exposed strain gages are shown in Figure 13 during recovery.

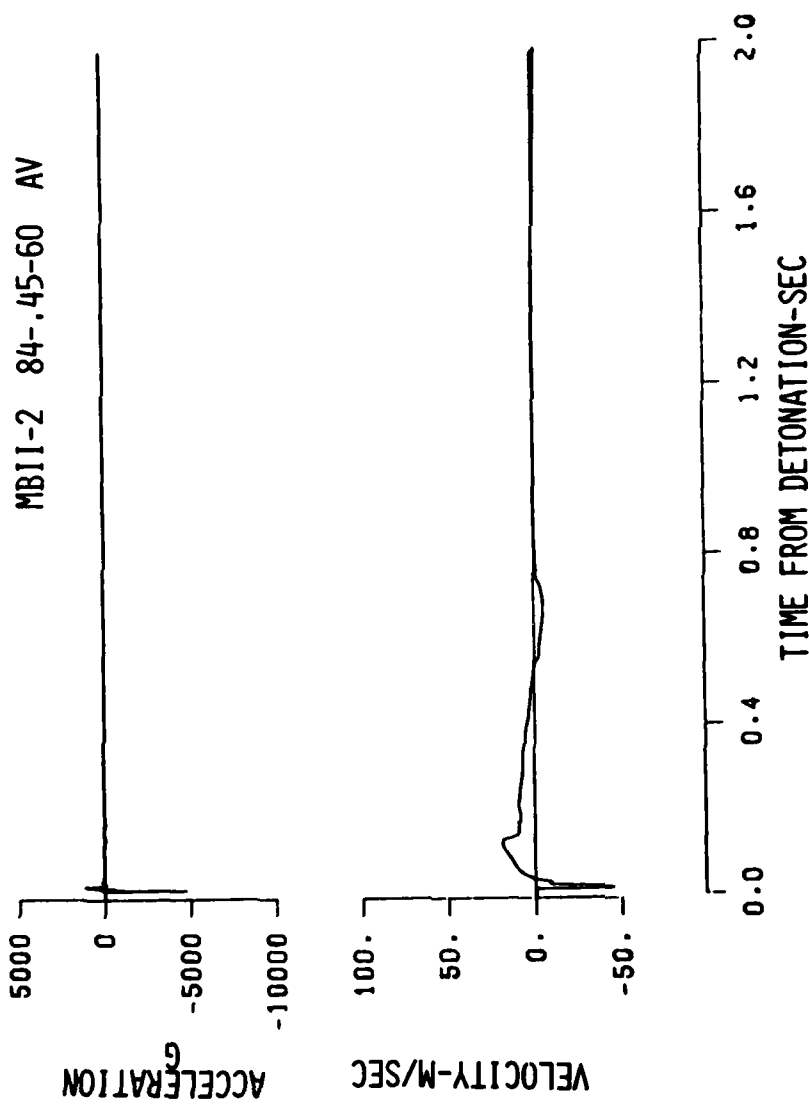

FIGURE 12 - A TYPICAL ACCELEROMETER RECORD WITH
ITS INTEGRAL.

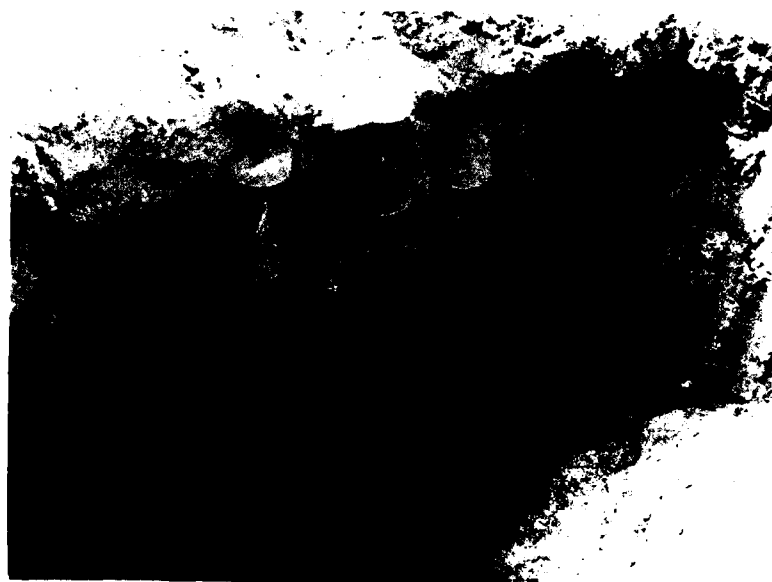

FIGURE 13 - THE STRAIN GAGES AT 240°,
84 M DURING RECOVERY.

Peak vertical accelerations of from -6500 g at 0.3 m to -1200 g at 1.2 m depth were recorded. Two gages, the ones at 0.6 m and 0.9 m indicated gage malfunction. The records from the other gages are shown in Figure 14. The overpressure was not as high here as at 60⁰ so the strains are not as severe.

Post test strains were obtained during recovery and are tabulated in Table 2. The final strain is compressional at this location. The

Table 2. Post test strain vs depth from Test 2.

<u>Depth m</u>	<u>Strain - %</u>
.3	-5
.45	-2
.6	-3
.9	-2
1.2	-4

gage records indicate the typical behavior where the soil compresses during the positive air shock and then overexpands during the rarefaction phase. However, during this overexpansion, there is a small positive pressure wave that can just be discerned on the pressure record at 0.13 sec. This is enough to markedly influence the strain. A small negative acceleration can be seen traveling down through the test bed also. The wave speed of the initial wave through the test bed is about 130 m/sec \pm 16 m/sec. The wave speed of the second pulse is 16 m/sec \pm 2 m/sec; an interesting observation that a wave recompressing this expanding soil travels at a speed 1/8 the speed of the original wave in both the 240⁰ and 60⁰-84 m locations.

At one hundred eighty degrees six meters from the array center, six strain gages were placed with stress gages and accelerometers nearby. The material here had to be moistened for several days before it was

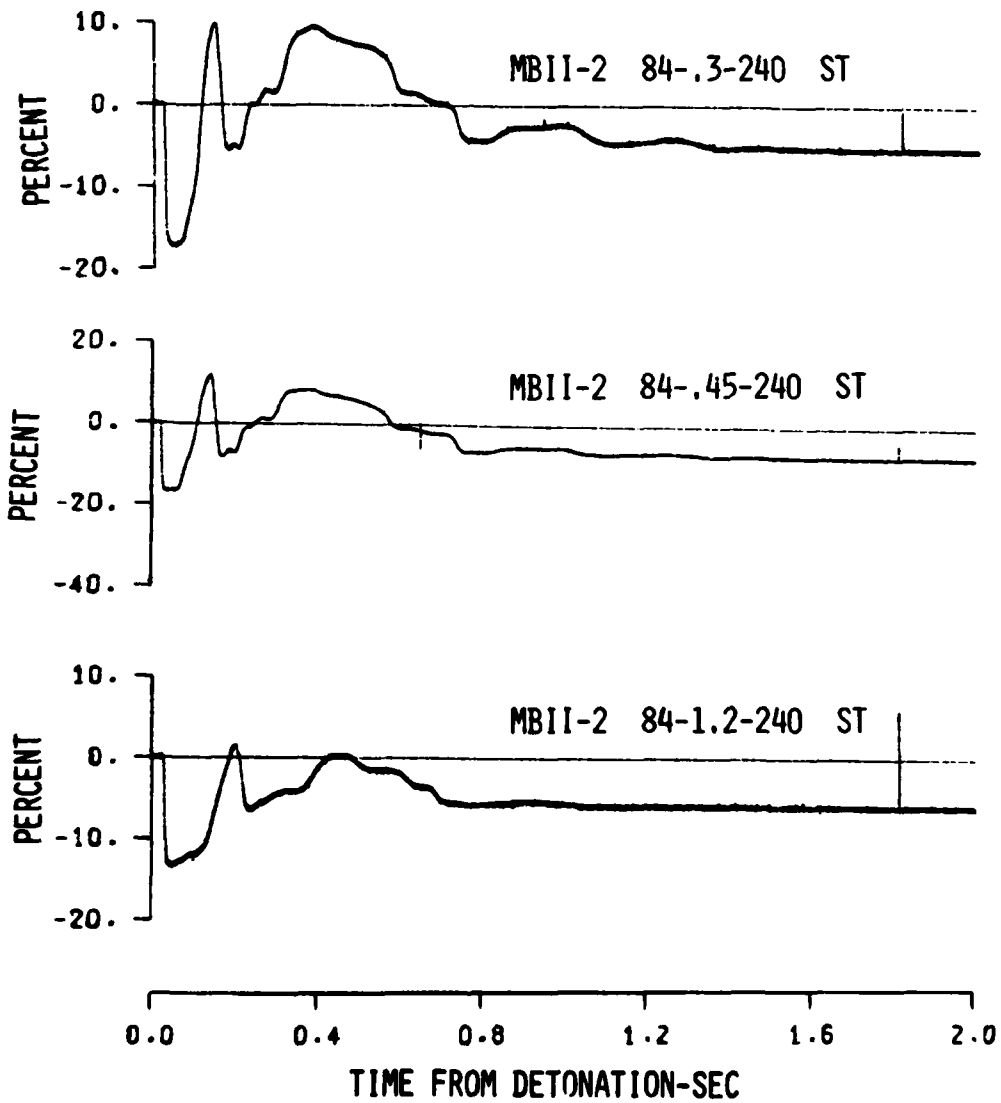

FIGURE 14 - STRAIN RECORDS FROM GAGES AT 240°, 84 M.

competent enough to allow an excavation with a vertical wall. The wall the gages were in was essentially on a radius from the center of the explosive array. The data are all meaningful in a sense but all of the strain gages except the ones at 1.2 m and 1.5 m depth were extended so far that the cores of the LVDT's were completely pulled out. The upper three gages overextended an unknown amount and then recompressed. The gage tubes were no longer aligned after extension so the tubes came down side-by-side with the top half of the gage toward the array center as in Figure 15. The gages at 0.9 and 1.2 m overextended but came together with the tubes intersecting as in Figure 16 which shows the gages at 1.2 m and 1.5 m. The data from all of these gages are shown in Figure 17.

Accelerations of 700 g at 0.3 m to 250 g at 1.2 m were measured which is reasonable based on the pressure data. A typical accelerometer record and its integral are shown in Figure 18.

The data from the spool gages are obviously showing the LVDT core being removed from the gage which results in a positive signal and as the core continues to leave the gage, the LVDT goes back toward a balanced condition and when the core is totally removed, the LVDT is essentially in an electrical and magnetically nulled condition. The signals on all of the gages but the one at 0.9 m, which was found with the core out of the LVDT, show signal structure after the strain has ceased. This might be due to stressing the LVDT as the top tube had cut into the lower one for about 1 cm, displacing the LVDT. The gage at 0.6 m suffered some other kind of distress, as it should have returned to near zero strain when the core was pulled out. The gage at 1.5 m was half in a coarse sand and half in the upper material. The data recovered from it indicate that the extensive surface material expansion stopped at or above this depth. The stress gages do not indicate a severe decrease in stress level but the peak particle velocity is falling off more rapidly than stress.

Recovery of more detailed information from these gages is possible by using the calibration curve for the gage shown in Figure 19. The gage was completely compressed and then stepwise extended until the core was

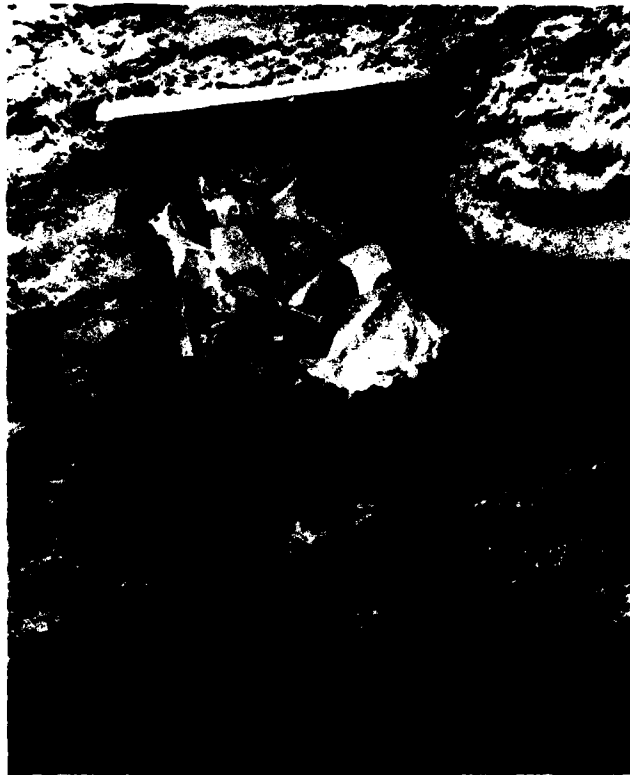

FIGURE 15 - OVEREXTENDED STRAIN GAGE
AT 180°, 6 M



FIGURE 16 - APPEARANCE OF GAGES AT
1.2 AND 1.5 M DURING RECOVERY.

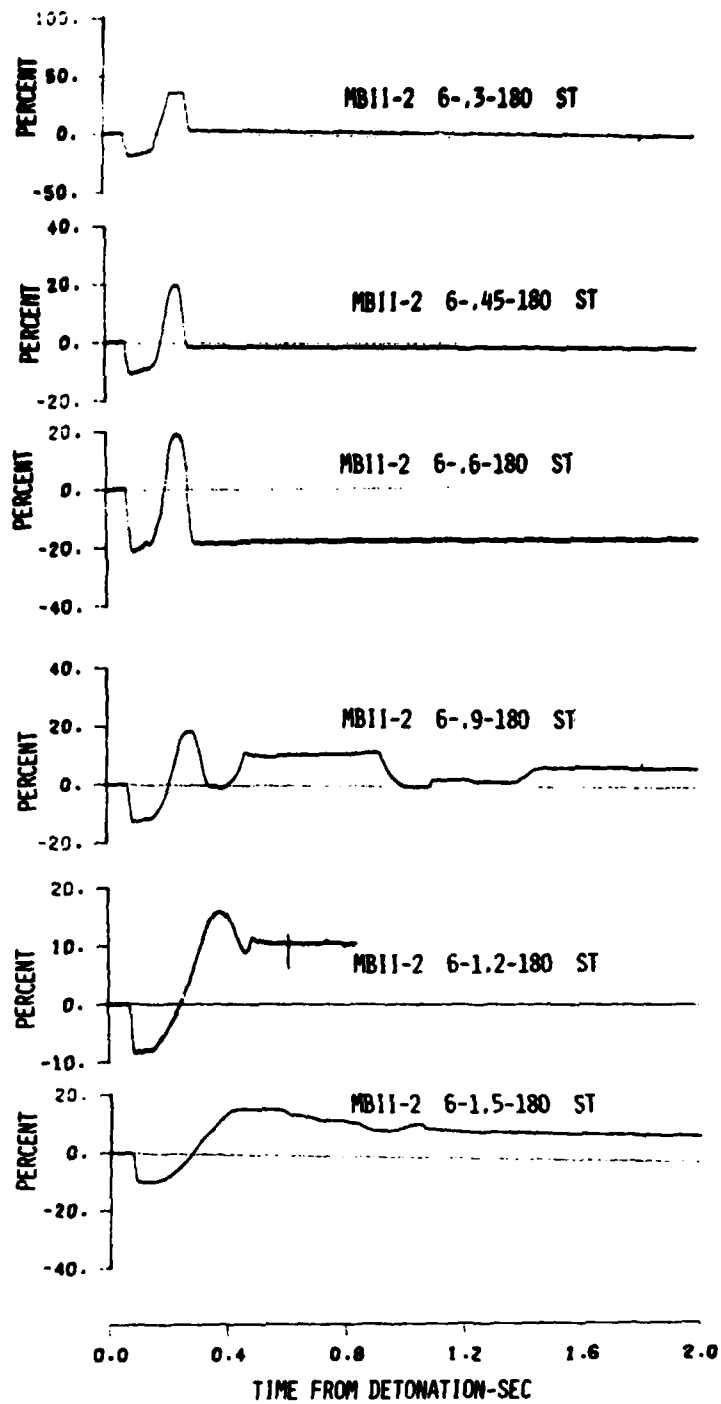

FIGURE 17 - STRAIN RECORDS FROM GAGES AT 180°-6 M.

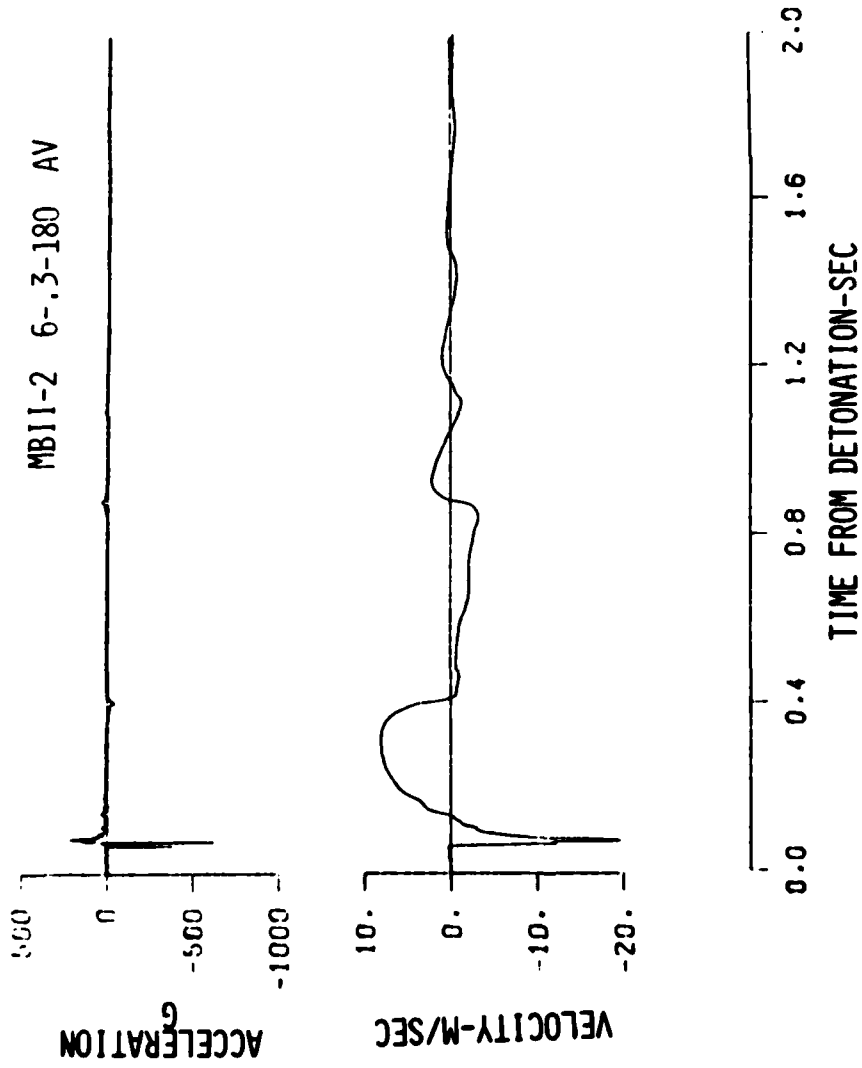

FIGURE 18 - TYPICAL ACCELEROMETER RECORD WITH ITS
INTEGRAL FROM 180°-6 M.

removed from the transformer. The normalized voltage-strain curve is then applied to the data from the overextended gages assuming that the overextension occurred as a single extension. The unfolded data is shown in Figure 19. The strain rate at 6 m depth appears to be stabilizing at about 450%/sec at 275 msec when the core left the transformer. The strain rate at 45 m and 0.9 m is decreasing when complete separation occurs at about 290 msec and 350 msec, respectively. The strain gage at 1.2 m is recompressing after an extension to about 30% strain, but the tubes are separated and are not aligned properly for telescoping to take place. The gage then locks up at about 450 msec. The gage at 1.5 m is behaving in a "normal" fashion.

The value of the negative phase pressure cannot be obtained from the pressure record with any accuracy. However, if the material is lifted and put in a free fall condition, the negative phase pressure (pressure below atmospheric) that would lift a block of material with no strength could be crudely considered to be $P = \rho g d$ where P is the negative phase pressure, ρ is the soil density, d is the depth to which soil can be lifted against gravity and g is the acceleration of gravity, $\rho = 1.25$ and if d is taken as 1.5 m, then $P = 0.015$ MPa, a reasonable value for the negative phase pressure.

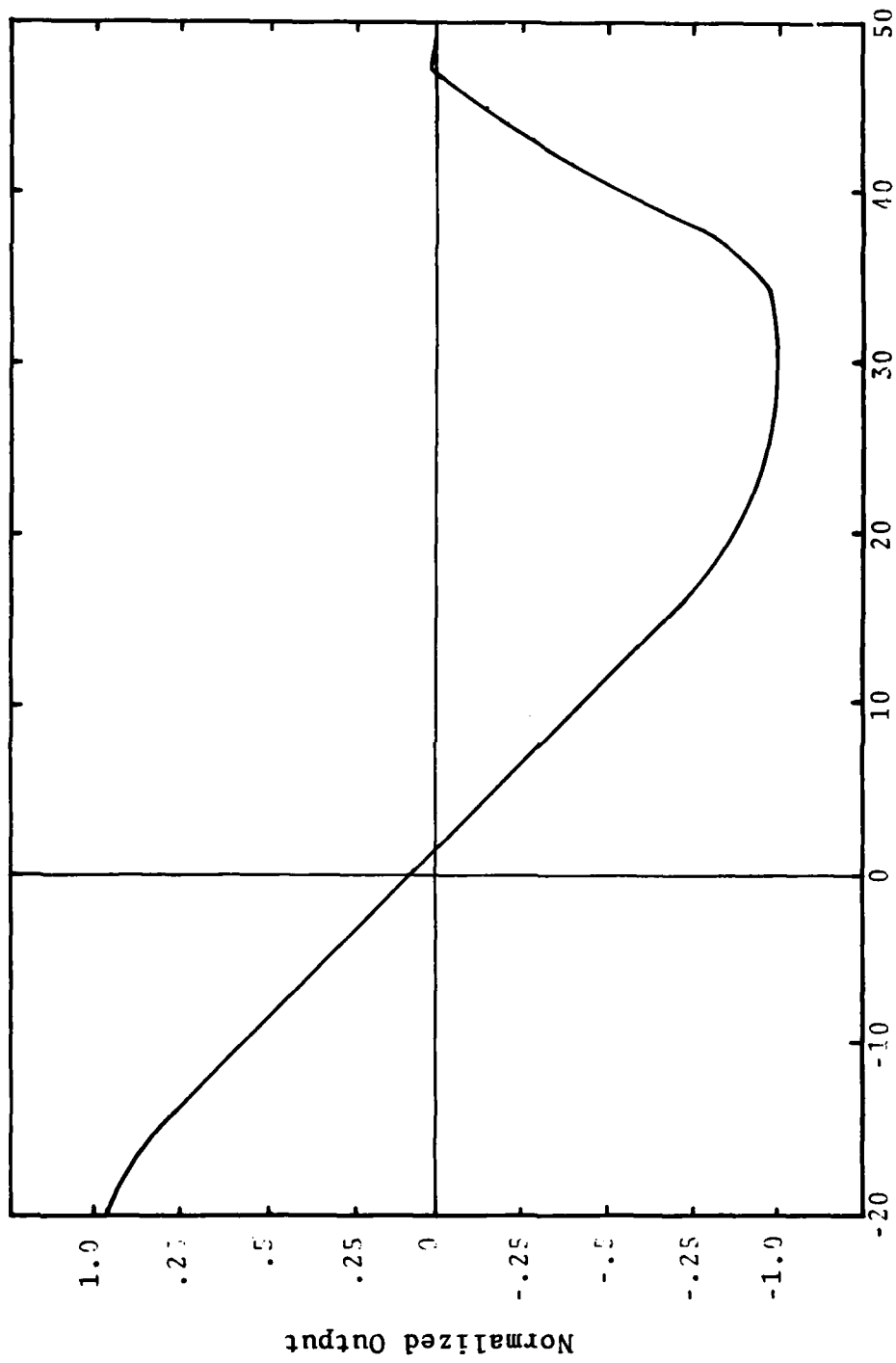

FIGURE 19 - STRAIN GAGE CALIBRATION CURVE.

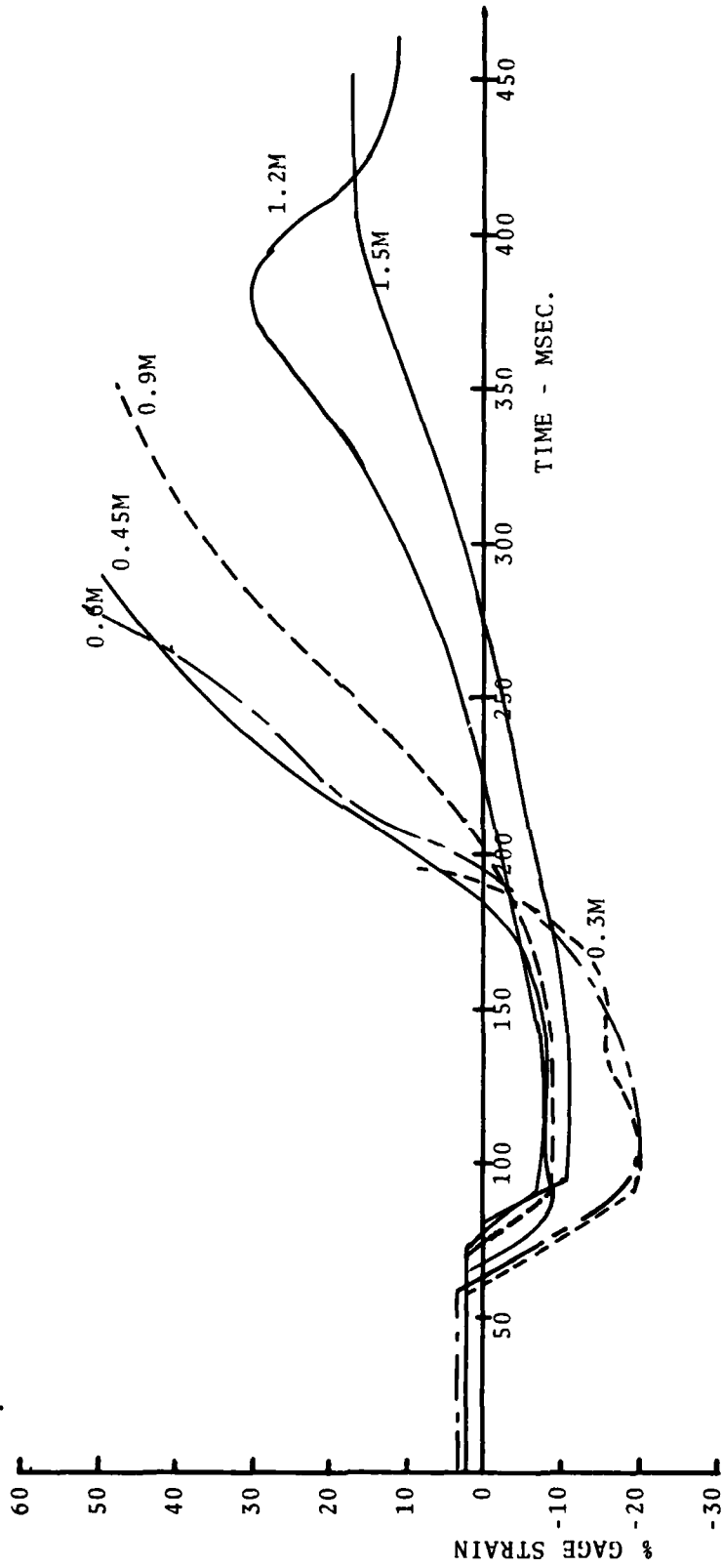

FIGURE 20. UNFOLDED STRAIN FROM 180 - 6M.

REFERENCES

1. Swift, L. M., Sachs, D. C. and Sauer, F. M., "Operation Plumbob - Project 1.4, GROUND ACCELERATION, STRESS, AND STRAIN AT HIGH INCIDENT OVERPRESSURES," WT-1404, Stanford Research Institute, Menlo Park, Ca., 1961.
2. Perret, W. R., "Report to the Test Director, EARTH STRESSES AND EARTH STRAINS," WT-503, Sandia Corporation, Albuquerque, New Mexico, September 15, 1952.
3. Perret, W. R. and Gentry, V. L., "Operation Upshot-Knothole, Project 1.4, FREE-FIELD MEASUREMENTS OF EARTH STRESS, STRAIN, AND GROUND MOTION," WT-716, Sandia Corporation, Albuquerque, New Mexico, February 1955.
4. Truesdale, W. B. and Schwab, R. B., "SOIL STRAIN GAGE INSTRUMENTATION," AFWL-TR-65-207, Kirtland Air Force Base, New Mexico, April 1966.
5. Ingram, J. D., "Development of a Free-Field Soil Stress Gage for Static and Dynamic Measurements," Technical Report No. 1-814, February 1968, U.S. Army Engineer Waterways Experiment Station, CE, Vicksburg, Miss.

DISTRIBUTION LIST

DEPARTMENT OF DEFENSE

Assistant to the Secretary of Defense
Atomic Energy
ATTN: Executive Assistant

Defense Advanced Rsch. Proj. Agency
ATTN: TIO

Defense Technical Information Center
12 cy ATTN: DD

Defense Nuclear Agency
ATTN: DDST
2 cy ATTN: SPSS
4 cy ATTN: TITL
ATTN: SPTD

Field Command
Defense Nuclear Agency
ATTN: FCPR
ATTN: FCT
ATTN: FCTMOF

Federal Emergency Management Agency
ATTN: Asst. Dir. for Rsch., J. Buchanon

Field Command
Defense Nuclear Agency
Livermore Division
ATTN: FCPRL

Commandant
NATO School (SHAPE)
ATTN: U.S. Documents Officer

Under Secretary of Defense for Rsch. & Engrg.
ATTN: Strategic & Space Systems (OS)

DEPARTMENT OF THE ARMY

Harry Diamond Laboratories
Department of the Army
ATTN: DELHD-I-TL
ATTN: DELHD-N-P

U.S. Army Ballistic Research Labs
ATTN: DRDAR-BLV
ATTN: DRDAR-TSB-S
ATTN: DRDAR-BLE, J. Keefer

U.S. Army Cold Region Res. Engr. Lab.
ATTN: CRREL-EM

U.S. Army Engr. Waterways Exper. Station
ATTN: F. Hanes
ATTN: J. Ingram
ATTN: Library
ATTN: L. Ingram
ATTN: W. Flathau

U.S. Army Materiel Dev. & Readiness Command
ATTN: DRXAM-TL

U.S. Army Nuclear & Chemical Agency
ATTN: Library

DEPARTMENT OF THE NAVY

Civil Engineering Laboratory
Naval Construction Battalion Center
ATTN: Code L08A
ATTN: R. Odello

David W. Taylor Naval Ship R&D Center
ATTN: Code L42-3
ATTN: Code 1770

Naval Facilities Engineering Command
ATTN: Code 09M22C

Naval Ship Engineering Center
ATTN: Code 09G3

Office of Naval Research
ATTN: Code 715

Naval Surface Weapons Laboratory
White Oak Laboratory
ATTN: Code F31

DEPARTMENT OF THE AIR FORCE

Air Force Institute of Technology, Air University
ATTN: Library

Air Force Weapons Laboratory
ATTN: DEX, J. Renick
ATTN: SUL
ATTN: DEX
ATTN: DE, M. Plamondon

Assistant Chief of Staff
Intelligence
Department of the Air Force
ATTN: INT

DEPARTMENT OF ENERGY

Department of Energy
Albuquerque Operations Office
ATTN: OTID

Department of Energy
Nevada Operations Office
ATTN: Mail & Records for Technical Library

DEPARTMENT OF ENERGY CONTRACTORS

Lawrence Livermore Laboratory
ATTN: Document Control for Technical
Information Dept. Library

Oak Ridge National Laboratory
ATTN: Civ. Def. Res. Proj., Mr. Kearny

Sandia Laboratories
ATTN: Document Control for 3141
ATTN: Document Control for A. Chabar
ATTN: Document Control for L. Vortman

DEPARTMENT OF ENERGY CONTRACTORS (Continued)

Sandia Laboratories
ATTN: Document Control for Library and
Security Classification Division

OTHER GOVERNMENT AGENCIES

Central Intelligence Agency
ATTN: OSI/NED, J. Ingley

Department of the Interior
U.S. Geological Survey
ATTN: D. Roddy

DEPARTMENT OF DEFENSE CONTRACTORS

Acurex Corp.
ATTN: K. Triebes

Aerospace Corporation
ATTN: Technical Information Services
ATTN: P. Mathur

Agbabian Associates
ATTN: M. Agbabian

Artec Associates, Inc.
ATTN: D. Baum

BDM Corp.
ATTN: T. Neighbors
ATTN: Corporate Library

Boeing Co.
ATTN: B. Lempriere
ATTN: Aerospace Library

California Research & Technology, Inc.
ATTN: K. Kreyenhagen

Civil Systems, Inc.
ATTN: J. Bratton

Develco, Inc.
ATTN: L. Rorden

Effects Technology, Inc.
ATTN: R. Wengler

EG&G Washington Analytical Services Ctr., Inc.
ATTN: Library

Electromechanical Sys. of New Mexico, Inc.
ATTN: R. Shunk

Eric H. Wang Civil Engineering Rsch. Facility
University of New Mexico
ATTN: N. Baum

General Electric Company-TEMPO
ATTN: DASIAC
ATTN: J. Shoutens

Geocenters, Inc.
ATTN: L. Isaacson

DEPARTMENT OF DEFENSE CONTRACTORS (Continued)

H-Tech Labs, Inc.
ATTN: B. Hartenbaum

IIT Research Institute
ATTN: Documents Library

University of Illinois
Consulting Services
ATTN: W. Hall
ATTN: N. Newmark

JAYCOR
ATTN: H. Linnerud

Kaman Sciences Corporation
ATTN: Library
ATTN: D. Sachs

Merritt CASES, Inc.
ATTN: J. Merritt
ATTN: Library

Physics Applications, Inc.
ATTN: C. Vincent

Physics International Company
ATTN: Technical Library
ATTN: F. Sauer/C. Godfrey

R & D Associates
ATTN: C. MacDonald
ATTN: J. Lewis
ATTN: Technical Information Center

Science Applications, Inc.
ATTN: Technical Library

Science Applications, Inc.
ATTN: J. Dishon

Science Applications, Inc.
ATTN: B. Chambers, III

Science Applications, Inc.
ATTN: K. Sites

Southwest Research Institute
ATTN: A. Wenzel
ATTN: W. Baker

SRI International
ATTN: B. Gasten/P. De Carli
ATTN: G. Abrahamson

Systems, Science & Software, Inc.
ATTN: Library
ATTN: D. Grine

Terra Tek, Inc.
ATTN: S. Green

TRW Defense & Space Sys. Group
ATTN: Technical Information Center
2 cy ATTN: P. Dai

DEPARTMENT OF DEFENSE CONTRACTORS (Continued)

TRW Defense & Space Sys.Group
ATTN: E. Wong

Weidlinger Associates
Consulting Engineers
ATTN: M. Baron

DEPARTMENT OF DEFENSE CONTRACTORS (Continued)

Weidlinger Associates
Consulting Engineers
ATTN: J. Isenberg