

AD-A079 953

MATERIALS RESEARCH LABS ASCOT VALE (AUSTRALIA) F/6 7/4  
PERFORMANCE OF A GEL PERMEATION CHROMATOGRAPH AND ITS USEFULNES---ETC(U)  
JAN 79 I GRABOVAC, C E MORRIS

UNCLASSIFIED

NL

1-1  
of 2 pages

END  
DATE  
FILMED  
2 80  
DOD

12  
B.S.



ADA 079953

**DEPARTMENT OF DEFENCE**  
**DEFENCE SCIENCE AND TECHNOLOGY ORGANISATION**  
**MATERIALS RESEARCH LABORATORIES**

MELBOURNE, VICTORIA

**REPORT**

**MRL-R-725** ✓

PERFORMANCE OF A GEL PERMEATION CHROMATOGRAPH AND ITS USEFULNESS  
IN EXAMINING MIXTURES OF ORGANIC MATERIALS

Ivan Grabovac and Carolyn E.M. Morris

DDC FILE COPY

Approved for Public Release

DDC  
RECEIVED  
JAN 29 1980  
A



© COMMONWEALTH OF AUSTRALIA 1979

JANUARY, 1979

80 1 28 006

THE UNITED STATES NATIONAL  
TECHNICAL INFORMATION SERVICE  
IS AUTHORISED TO  
REPRODUCE AND SELL THIS REPORT

APPROVED  
FOR PUBLIC RELEASE

DEPARTMENT OF DEFENCE  
MATERIALS RESEARCH LABORATORIES

REPORT

14 MRL-R-725

6 PERFORMANCE OF A GEL PERMEATION CHROMATOGRAPH AND ITS USEFULNESS  
IN EXAMINING MIXTURES OF ORGANIC MATERIALS

10 Iyan/Grabovac and Carolyn E.M./Morris

ABSTRACT

↓  
As part of a programme of assessing the molecular properties of organic materials of defence interest, the performance of a locally designed gel permeation chromatograph fitted with a refractive index (R.I.) detector and an evaporative analyser (E.A.) detector has been examined. It was found that with the R.I. detector the performance is similar to that of other instruments. The response of the E.A. detector was found to depend on a number of operating conditions in an unforeseen manner which limits the usefulness of this detector. However, molecular weight distributions determined with the E.A. detector showed good agreement with the R.I. results.

Using the two detectors simultaneously, a study has been made of a complex mixture of epoxy resins (an aircraft adhesive) and it has been shown that information relevant to the performance of advanced organic materials can be provided by such studies

11 Jan 79

12 34

Approved for Public Release

- A -

© COMMONWEALTH OF AUSTRALIA 1979

POSTAL ADDRESS: Chief Superintendent, Materials Research Laboratories  
P.O. Box 50, Ascot Vale, Victoria 3032, Australia

409 014 JSM



C O N T E N T S

	<u>Page No.</u>
1. INTRODUCTION	1
2. GENERAL DESCRIPTION	2
2.1 Pumping System	2
2.2 Columns	2
2.3 Detection System	3
(i) Differential Refractive Index Detector (R.I.)	3
(ii) Clanor Evaporative Analyser Detector (E.A.)	3
3. PERFORMANCE EVALUATION	4
3.1 R.I. Detector	4
3.1.1 <i>Dependence on Concentration</i>	5
3.1.2 <i>Dependence on Molecular Weight</i>	5
3.2 E.A. Detector	5
3.2.1 <i>Effect of Primary Air Pressure and Secondary Air Flow Rate</i>	5
3.2.2 <i>Effect of Operating Conditions on Response - Concentration Relation</i>	6
(i) <i>Primary Air Pressure</i>	6
(ii) <i>Lamp Voltage</i>	6
(iii) <i>Lamp Age</i>	6
(iv) <i>Exhaust Air</i>	6
(v) <i>Detector's Specificity</i>	7
3.2.3 <i>Dependence on Molecular Weight</i>	7
3.2.4 <i>Reliability of the Clanor E.A. Detector</i>	7
3.3 Comparison between E.A. and R.I. Detectors in Determination of Weight-Average and Number-Average Molecular Weight	8
3.4 Usefulness of Combined Detection System	8
4. ANALYSIS OF A STRUCTURAL AIRCRAFT ADHESIVE	9
5. CONCLUSIONS	10
REFERENCES	10

\* \* \*

Accession for	
NTIS GR&I	<input checked="" type="checkbox"/>
DDC TAB	<input type="checkbox"/>
Unannounced	<input type="checkbox"/>
Justification	<input type="checkbox"/>
By _____	
Distribution _____	
Availability _____	
Disc.	Availability/ special
A	

PERFORMANCE OF A GEL PERMEATION CHROMATOGRAPH  
AND ITS USEFULNESS IN EXAMINING MIXTURES  
OF ORGANIC MATERIALS

1. INTRODUCTION

As part of MRL's work on organic materials, attention is paid to the changes in molecular properties which occur during storage and use. These changes, especially alterations in the molecular weight distribution, can substantially modify the properties and performance of the materials. The technique for examining molecular weight distribution is gel permeation chromatography (GPC) which is a method for the separation, purification and analysis of high molecular weight substances.

The separation is usually carried out on columns packed with a gel or some other porous material and completely filled with solvent: the sample is dissolved in the same solvent before injection on to the column. As the solvent flows through the columns, solute molecules are retarded according to their ability to permeate into the pores of the packing material, that is, small molecules spend longer on the column than large molecules. The order of elution, large molecules first - small molecules last, is in contrast to the order which is generally observed in other chromatographic techniques.

Recently, an Australian designed and built instrument, incorporating a new type of detector, was obtained to assist in our work on the characterisation of advanced organic materials of defence interest. As the operating conditions and performance of this equipment have not been published, this paper reports on specific aspects of interest, especially the detector performance in relation to that of the commonly used detector. It also reports on the suitability of such equipment to provide useful information on complex mixtures of organic materials, taking as an example aircraft adhesives.

## 2. GENERAL DESCRIPTION

The Clanor Gel Permeation Chromatograph is a custom made instrument built by a small Melbourne-based company, Clanor Instruments\*. The basic design principle is the same as the Waters Associates' instrument model 200. It consists of two separate units (Figure 1): one unit houses the solvent reservoir, pump and necessary plumbing, Refractive Index detector (R.I.), Evaporative Analyser detector (E.A.), two-pen strip-chart recorder and related electronic components. The other unit consists of an oven containing columns, injection valve, adjustable splitter and temperature control unit. The whole instrument shown schematically in Figure 2, can be subdivided into three main systems :

1. Solvent pumping system
2. Columns
3. Detection system

### 2.1 Pumping System

The pumping system comprises solvent reservoir, degasser, check valve (adjustable in line), heat-exchange coil, shut-off valve, filters, pump, Bourdon-type tubes, restrictors and pressure gauge. All the tubing and components through which the solvent flows are stainless steel or PTFE.

A 20 l, stainless steel drum is used as the solvent reservoir with a glass side-tube as the level indicator. A large reservoir capacity is necessary to minimise the effects of solvent quality changes (i.e. refractive index variations). Provision for work under a nitrogen atmosphere is also made. The solvent is heated to about boiling point in the degasser to eliminate dissolved gases, cooled down in the heat exchange coil and filtered before entering the pump. This pump, which is a reciprocating positive-displacement Milton Roy Minipump, has a maximum output of 2.8 ml/min and the precision of the adjustable delivery volume is claimed to be  $\pm 0.3\%$ . The damping system, to eliminate the pressure pulses, consists of two lengths of tubing of about 4 m of internal diameter 0.15 mm and two Bourdon-type tubes. The shut-off valve enables the solvent flow to be diverted back to the reservoir via a check-valve.

The solvent back-pressure generated by flow restriction is displayed on the pressure gauge.

### 2.2 Columns

Columns normally consist of cross-linked polystyrene gel packed inside stainless steel tubes 1.2 m in length, of internal diameter 9.5 mm. They are characterised by an exclusion limit (given in A) which is related to the pore size associated with the separation process.

---

\* Present address: Clanor Instruments, P.O. Box 75, Balwyn, Victoria 3103

A bank of two, three or four columns connected in series is a typical separation line-up. The selection of the column combination depends on the molecular size distribution of the sample under investigation. Since the R.I. detector is very sensitive to minor differences in flow rate between the sample and reference cells, it is necessary to match the back-pressure of the sample and reference streams by insertion of a set of columns in the reference stream. The tee piece, (Figure 2) splits the solvent stream in two, one of which enters the reference columns and the other the sample column via the six-port valve and injection loop. All columns used in this work contained Waters Styragel packing.

### 2.3 Detection System

There are two detectors provided -

- (i) Differential Refractive Index detector; and
- (ii) The Clanor Evaporative Analyser detector.

(i) The Differential Refractive Index detector is a Varian instrument, Model 02-1528-02. The difference in refractive index between the two streams, positive or negative depending on the solute-solvent system, is displayed on a recorder. The minimum detectability claimed by the manufacturer is  $\pm 1 \times 10^{-7}$  R.I. units.

Differential refractometry, while satisfactory for monitoring the fractionation of a mixture of compounds, can be used for the quantitative estimation of the amount of the various compounds only if response factors are known for each component present. R.I. detectors are very sensitive to flow and temperature variations.

(ii) The Clanor Evaporative Analyser detector consists of three stages : atomiser, evaporator and detector. It was originally designed by workers at Union Carbide Ltd., Sydney as a detector for liquid chromatography especially suitable for use with mixed solvents [1]. The particular features claimed were a steady baseline and good sensitivity for a wide range of compounds provided they were of significantly lower vapour pressure than the solvent. Further development of this detector was undertaken by Clanor Instruments who brought it to its present form. The arrangement is now as shown in Figure 3. The sample column eluant passes through the atomising head. A primary air stream entering at the top of the detector column assists atomisation of the liquid by spraying it inside the heated evaporative column. The secondary air, which enters at the bottom of the evaporative column, flows upwards outside and downwards inside the resistance heated gauze column carrying the atomised solvent stream. As the solvent droplets pass down the heated column, the solvent evaporates and any non-volatile solutes present remain as a fine cloud of particles. The secondary air thus to some extent enters the central region through this fine gauze, thereby assisting to prevent deposition of the atomised mist on the walls of the column. When this cloud of particles passes through the light path at the bottom of the column, the light scattered by the particles is detected by a photo-multiplier located at an angle of  $120^\circ$  to the incident light beam. The signal from the photo-multiplier is amplified and displayed on a recorder.

The E.A. detector response should be proportional to the amount of sample present in the eluant providing that none is lost during the evaporation of the solvent, and that the particles are of a uniform size and shape.

### 3. PERFORMANCE EVALUATION

Initially, the instrument had some technical problems. Problems such as unsteady flow of solvent through the plumbing system, solvent dead volume and frequent blockages of the hypodermic tubing connecting the splitter with detectors, were eventually resolved.

It was found that although, according to thermocouple measurements, the temperature in the oven becomes constant in about an hour, the solvent flow rate requires some 6-8 hours to re-establish a steady value after the oven has been open. There is a temperature gradient of some 2°C over the length of the oven.

It was also observed that high primary air pressures in the E.A. detector create a suction effect thereby affecting the ratio of the split in the liquid stream.

The major part of the assessment of the instrument's performance was directed to the performance of the detectors. For this purpose, a series of experiments was made using polystyrene (PS) standards from the Pressure Chemical Company, Pittsburgh, Pennsylvania covering a molecular weight range of  $6.55 \times 10^5$  down to  $1.2 \times 10^3$  (Table 1) and also a commercial sample of poly(methyl methacrylate) (PMMA) Diakon MG 101 from I.C.I. Australia Ltd.

Chloroform, A.R. grade, was redistilled through a fractionating column, having ~200 theoretical plates, to eliminate ethyl alcohol acting as the stabilizer. Minor differences in refractive index were minimised by mixing redistilled solvent in a large container.

Three column sets were used consisting of 1.2 m column sections packed with Styragel beads obtained from Waters Associates. The porosities of the beads are given in Table 2.

In all cases the chloroform flow rate was 1 ml/min and the injection time 1 min. The samples, in the concentration range 40 to 2000 ppm, were filtered before being loaded into the injection loop and injected. For experiments above room temperature (30°C) the sample was thermally equilibrated in the injection loop for 1 min. For assessment of results the area under the peak was integrated by the use of a compensating planimeter type KP-27.

#### 3.1 R.I. Detector

The performance of the R.I. detector was assessed by determining its dependence on solute concentration and molecular weight.

### 3.1.1 Dependence on Concentration

The detector's dependence on solute concentration was determined by the use of PS sample M.W.  $3.45 \times 10^4$  in the concentration range from 180 to 1400 ppm. Column set A was employed and the experiment performed at room temperature.

Results are shown in Figure 4. It is clear that in the range of polymer concentration employed the R.I. detector response is a linear function of concentration.

### 3.1.2 Dependence on Molecular Weight

The effect of molecular weight was observed through the use of 2000 ppm PS samples on Column Set C at the oven temperature of 30°C.

Detector response, given in R.I. units, is plotted against molecular weight (Figure 5). In the low molecular weight region significant changes in the refractive index difference occur; however, as the molecular weight of the polymer increases, the changes in the refractive index difference become less significant. A close agreement was found between these results and those of Margerison et al. [2].

## 3.2 E.A. Detector

The baseline in the E.A. chromatographs is normally extremely steady. It was found that insufficiently high temperatures in the E.A. heated column resulted in incomplete evaporation of the solvent which produces an oddly shaped, "spikey" chromatographic peak.

The effect of primary air pressure and secondary air flow rate on the detector response was studied, as was the detector's dependence on the concentration of the injected sample. In addition, as in the case of the R.I. detector, the effect of the molecular weight of the sample was determined.

### 3.2.1 Effect of Primary Air Pressure and Secondary Air Flow Rate

These studies were conducted on column set A at ambient temperature using 2000 ppm PMMA samples. The detector's response, given as the area under the peak vs primary air pressure, is illustrated in Figure 6 curve 1 with the secondary air flow fixed at 14 l/h. Similarly, the detector's response as a function of secondary air flow rate at a fixed primary air pressure of 125 kPa is shown in Figure 7 curve 1.

However, there is a point to be given some consideration. The results of two experiments carried out approximately three months apart, but otherwise under identical conditions, are presented in Figure 6 and 7. Subsequently, it was found that the longer PMMA was used as the sample, the lower was the detector's response. Examination revealed that PMMA deposits on the inside of the evaporative heater column. The previously determined optimum of the primary air pressure, (Figure 6) remained unaffected, but a change occurred in the optimum of the secondary air flow rate from the original 15 l/h to 8 l/h (Figure 7). Removal of the polymer deposits

reinstated the values initially determined. No such polymer deposition was discernible with polystyrene. Evidently, this deposition not only reduced the amount of polymer in the air stream passing through the light beam, but also affected the air flow pattern which, as further demonstrated below, alters the detector's response.

### 3.2.2 Effect of Operating Conditions on Response-Concentration Relation

As mentioned earlier, a linear relationship is assumed to exist between the detector's response and concentration. It was found that this relationship is dependent on various other factors such as: primary air pressure, lamp voltage, lamp age, air flow disruption and the detector's specificity. These effects were studied using column set A at room temperature and PS sample M.W.  $3.45 \times 10^4$  in the concentration range 50 to 1100 ppm.

(i) *Primary Air Pressure* - the effect of primary air pressure at 165, 125 and 85 kPa on the detector's response (given as an area under the peak) to the solute concentration is illustrated in Figure 7. In each case the secondary air flow rate (17 l/h), detector sensitivity (490V) and lamp voltage (7.5V) were kept constant. Only in the third case, where the primary air pressure applied was 85 kPa, was an approximately linear dependence of response on concentration found.

Repeating the conditions of curve 3 (Figure 8), but with a higher sensitivity (530V), modified this relationship as illustrated in Figure 9, curve 1; the lower primary air pressure of 62 kPa (curve 2) resulted in a further modification.

(ii) *Lamp Voltage* - the effect of lamp voltage (L.V.) at 7.5, 7.0, 6.5, and 6.0V on the detector's response as a function of concentration is shown in Figure 10. For these four curves the detector sensitivity (600V), primary air pressure (125 kPa) and secondary air flow rate (17 l/h) were kept constant.

(iii) *Lamp Age* - a significant change was observed in the detector's response on replacement of a burnt out lamp. Figure 11, curve 1 gives results obtained with an old projection lamp which had been used for approximately 1000 burning hours. A newly installed lamp increased the detector's response five-fold, as shown by curve 2. In both cases other conditions were identical to those given for Figure 8, curve 3.

In total, these findings severely limit the use of the E.A. detector as a simple means of determining the amount of material of a given molecular weight over extended periods of time since the exact operating conditions are virtually impossible to reproduce. It should be possible to overcome this at least partially by the use of calibration standards.

(iv) *Exhaust Air* - the effect of a disruption to the flow of the exhaust air is shown in Figure 12. Normally, curve 1, the instrument is connected to an exhaust system to remove solvent vapour and atomised sample. However, disconnecting the exhaust system from the instrument gives the results illustrated by curve 2. Operating conditions were identical in each case (sensitivity 600V, L.V. 6.5V, primary air pressure 125 kPa and secondary

air flow rate 17 l/h). This illustrates the influence of the particular air flow pattern established in the evaporative column on this detector's response.

(v) *Detector's Specificity* - an indication of the E.A. detector response to chemically and physically different samples under identical conditions is shown in Figure 13. Curves 1 and 2 represent results obtained for PS and PMMA samples respectively. On the basis of these results, the detector response is specific to the species being analysed as a smaller response was found with PMMA compared with PS. This is in keeping with the results obtained on the original model of the E.A. detector [1].

### 3.2.3 *Dependence on Molecular Weight*

The effect of molecular weight on the detector's response using column set C at 30°C was studied. The results, given as peak area per unit amount of sample passed through the detector, are illustrated in Figure 14. Additional samples were used for the low molecular weight range. These were di-cholesteryl adipate M.W. 883, recrystallised twice in a chloroform/ethyl alcohol (5:4) solvent mixture, cholesteryl stearate M.W. 653, recrystallised five times from ethyl alcohol, and anthracene M.W. 178, obtained from Merck.

From Figure 14, it can be seen that the E.A. detector's response remains constant for samples of M.W. above  $2 \times 10^3$ . Below that point a downward trend in the detector's response is indicated by the cholesterol derivatives and anthracene.

Since these compounds possess different physical and chemical properties to PS (see previous section), it is likely that other factors beside the decreasing molecular weight, such as the vapour pressure of a compound, are responsible for the detector's decreasing response. Compounds such as 1,2-dichlorobenzene and naphthalene pass through the E.A. detector unnoticed.

Therefore, from the results presented it can be concluded that sample separation down to M.W.  $2 \times 10^3$  can be determined by the use of this detector. Since the GPC itself is not designed to operate in a very low M.W. range, the decreasing detector response below a M.W. of  $2 \times 10^3$  is not critical and from that point of view its performance is satisfactory.

### 3.2.4 *Reliability of the Clanor E.A. Detector*

Our experience indicates doubtful reliability, chiefly as a result of frequent malfunction and rapid deterioration of electronic components. Some of the problems encountered in the detector's operation have been a sudden loss of sensitivity and a gradual decrease of voltage applied to the light source resulting in a reduction in the emitted light intensity. The effects of such a voltage drop could possibly be rectified by a light-intensity compensating unit if one was provided with the instrument. Furthermore, the projection lamp used with this detector is constantly operated with the base up, although the manufacturer's specification indicates a normal lamp burning rate is achieved in a base-down position and this may result in a shorter lamp life.

All these factors affect the detector's performance to the degree that it is very difficult to reproduce exactly any operating conditions employed in the past. Action has been taken to eliminate some of these problems by the replacement of electronic components and the redesign of essential new circuitry.

### 3.3 Comparison between E.A. and R.I. Detectors in Determination of Weight-Average and Number-Average Molecular Weight

A direct comparison between the E.A. and R.I. detectors' performance is given by the determination of the weight-average and number-average molecular weight ( $\bar{M}_w$  and  $\bar{M}_n$ ) of a sample of commercial polystyrene (STYRON 685, Dow Chemical (Aust.) Ltd.). Column set B was employed at 30°C.

The two detectors were connected in parallel to the column eluant by means of the splitter to produce simultaneously recorded chromatograms of about the same peak height and width. The  $\bar{M}_w$  and  $\bar{M}_n$  were calculated as described by Cazes [3]. Calibration curves for the column set (peak molecular weight vs elution volume) were constructed using PS samples given in Table 1, of the same concentration as the sample of interest. The fit to a straight line was excellent.

The calculated values are :

R.I. chromatogram ( $\bar{M}_w = 3.13 \times 10^5$ ,  $\bar{M}_n = 1.01 \times 10^5$  and  $\bar{M}_w/\bar{M}_n = 3.09$ )

E.A. chromatogram ( $\bar{M}_w = 2.91 \times 10^5$ ,  $\bar{M}_n = 0.96 \times 10^5$  and  $\bar{M}_w/\bar{M}_n = 3.04$ )

The method of measurements and calculations carried out on these chromatograms was identical and therefore the relative error incurred in the calculations was assumed to be of the same magnitude.

For each detector, the repeatability of the results for a given sample was about 5%. It can be seen that the agreement between the values determined by the two detectors is to about 5%, that is, to about the experimental error of the individual detectors.

Strictly speaking, the chromatogram in the E.A. case should be corrected to take account of the fact that, for a given compound, the response is not exactly proportional to the amount present. This departure from linearity seems unlikely to exceed about 5% (see Figure 9, for example) and the close agreement of the results in the calculation given above indicates that the overall effect is small.

### 3.4 Usefulness of the Combined Detection System

The amount of information and flexibility of a GPC as a whole depends very often on the type of detection system employed. In our case the R.I. and E.A. detectors should provide sufficient information for most polymers.

Each detector has its limitations arising, at least in part, from its principle of operation. Thus the R.I. detector has a small response if the difference in refractive index between solute and solvent is small. It is also very sensitive to solvent composition changes and to fluctuations in

temperature. The extreme stability of the base line of the E.A. detector and its insensitivity to minor solvent composition changes and to temperature fluctuations are distinct advantages. However, it frequently does not see low molecular weight compounds, even when they are present in substantial amounts. In the case of a chromatogram which contains a number of peaks, the areas of the peaks in the E.A. case can be taken, as a first approximation, as an indication of the relative amounts of the compounds present (provided their vapour pressure is low) whereas no such inference can be drawn from the R.I. trace without information on the refractive index of the compounds. Hence, the use of the two detectors simultaneously offers certain advantages when examining unknown materials.

#### 4. ANALYSIS OF A STRUCTURAL AIRCRAFT ADHESIVE

As part of a study on the room temperature ageing of a structural epoxy adhesive extensively used in the F111C, the changes with time in the molecular weight distribution of the uncured material were examined [4]. This work enabled an assessment to be made of the usefulness of this equipment in the examination of complex mixtures of compounds, such as are encountered in advanced organic materials of defence interest. The adhesive, which has a recommended shelf life of about six months at  $-18^{\circ}\text{C}$ , is imported into Australia. A study was undertaken to assess the effect of short times out of a freezer (or loss of dry ice during transport) on the composition of the adhesive and on its subsequent performance in service.

The adhesive is in the form of a film. The resin component was dissolved in chloroform, separated from its woven glass support, asbestos filler and the curing agent (dicyandiamide, which is only very slightly soluble in chloroform) and the GPC trace run using the two detectors in parallel, as described above (Section 3.3). The column set was four Styragel columns of nominal porosity  $3 \times 10^3$ ,  $1 \times 10^3$ , 500 and 200 Å. The chromatograms of the adhesive are shown in Figure 15. The molecular weight range, using a series of epoxy resins as calibrating materials, is from 270 to about 25,000.

Spectroscopic analysis showed that the adhesive consists of three epoxy types (and their oligomers) namely (a) a high molecular weight diglycidyl ether of bisphenol A, (b) a cresol novolac and (c) triglycidyl *p*-amino phenol. The proportions of these were estimated as (a) 10-15% of the resin, (b) ~40% and (c) ~45%. These three constitute about 75% of the material, the remainder being dicyandiamide (~7.5%), asbestos (~10%) and a woven glass support (~8.5%).

A sample of the adhesive was stored, with its protective backing in place, in a plastics bag at  $20^{\circ}\text{C}$ . At intervals, a piece was cut off and the chromatogram measured. The changes on ageing are illustrated in Figure 16. It is seen that the two detectors show basically the same features but that relative heights of various sections of the chromatograms differ, which is a reflection of the fact that the detectors operate on different principles. The curves suggest a change in refractive index is occurring in the material eluting first (up to an elution volume of about 130 ml) as well as a change in molecular weight distribution. The need to correct the E.A.

chromatograms for the effect of lamp age over the time scale of these experiments was somewhat inconvenient, but the baseline stability was a distinct advantage.

## 5. CONCLUSIONS

Early problems associated with the solvent flow have been eliminated, the effect of dead volume in the pumping system minimised and certain electronic problems at least partially overcome.

Within the operating limits, the performance of the instrument with the R.I. detector was found to be satisfactory and comparable to that reported in the literature. The performance of the E.A. detector was found to depend to an unexpected degree on a number of operating conditions but does enable determinations to be made of the weight and number average molecular weight of polymers to about the same degree of accuracy as the R.I. detector.

On the basis of the results presented in this report it can be concluded that the performance of the Clanor GPC at MRL, following various modifications to the plumbing and electronics, is satisfactory for the determination of molecular weight.

An extensive series of measurements with the two detectors on a polymer mixture of complex molecular weight distribution has shown that the baseline stability and overall reproducibility of the E.A. detector is very helpful but the slowly changing total response with lamp age is an inconvenience. It is therefore concluded that the E.A. detector is in principle a useful addition to the range of GPC detectors, but that the design is not yet the optimum.

## REFERENCES

1. Ford, D.L. and Kennard, W. (1966). *JOCCA*, 299.
2. Margerison, D., Bain, D.R. and Kiely, B. (1973). *Polymer*, 14, 133.
3. Gazes, J. (1966). *J. Chem. Ed.*, 43, (7); 43, (8).
4. Morris, C.E.M., Moritz, A.G. and Davidson, R.G. *Org. Coat. Plast. Chem. Preprints*, 40. (To be published).

T A B L E 1

POLYSTYRENE STANDARDS

Peak MW	Batch No.	$\bar{M}_w/\bar{M}_n$
$6.55 \times 10^5$	13a	<1.15
$1.96 \times 10^5$	1c	<1.06
$1.11 \times 10^5$	4b	<1.06
$3.45 \times 10^4$	7b	<1.06
$1.00 \times 10^4$	8b	<1.06
$4.00 \times 10^3$	11b	<1.10
$2.10 \times 10^3$	12b	<1.10
$1.20 \times 10^3^*$	-	-

\* Determined by Vapour Phase Osmometer

T A B L E 2

COLUMN SETS CONSISTING OF 1.2 m SECTIONS

Set	Porosity*	Theoretical Plates (per m)
A	$2.5 \times 10^4$	2183
B	$1.0 \times 10^6$	2173
	$2.5 \times 10^4$	
	$1.0 \times 10^3$	
C	$2.5 \times 10^4$	2017
	$1.0 \times 10^3$	
	$2.0 \times 10^2$	
	$6.0 \times 10$	

\* given in nominal Å units.

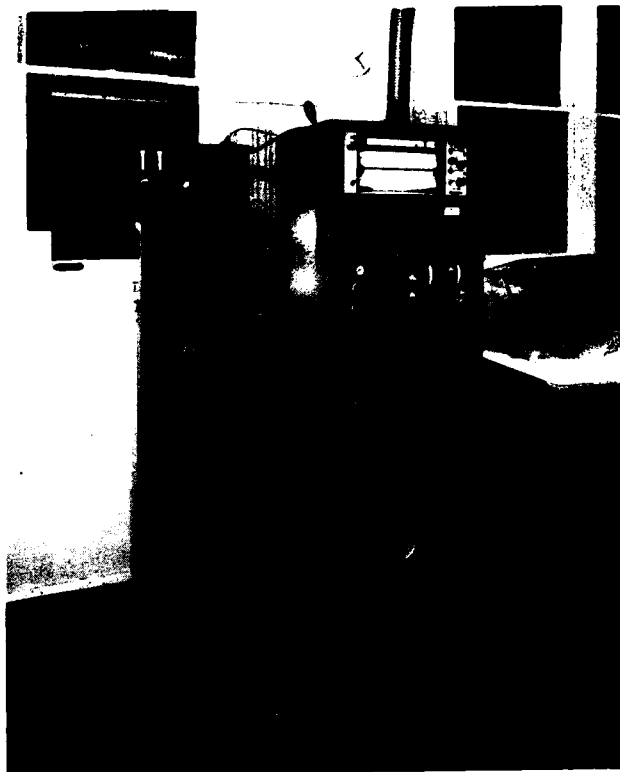

FIG. 1 - Clanor GPC

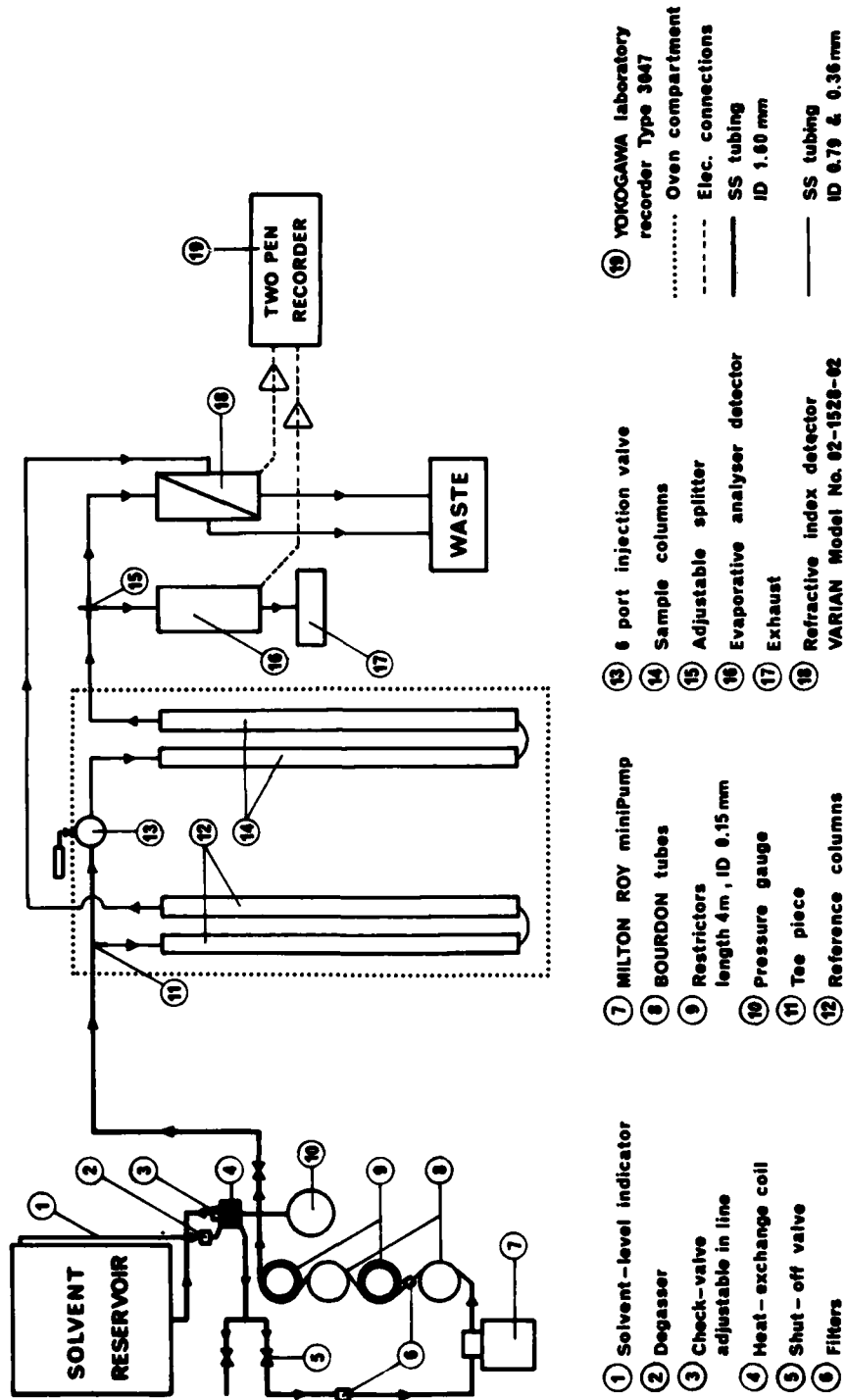

FIG. 2 - Schematic diagram - Clamor GPC

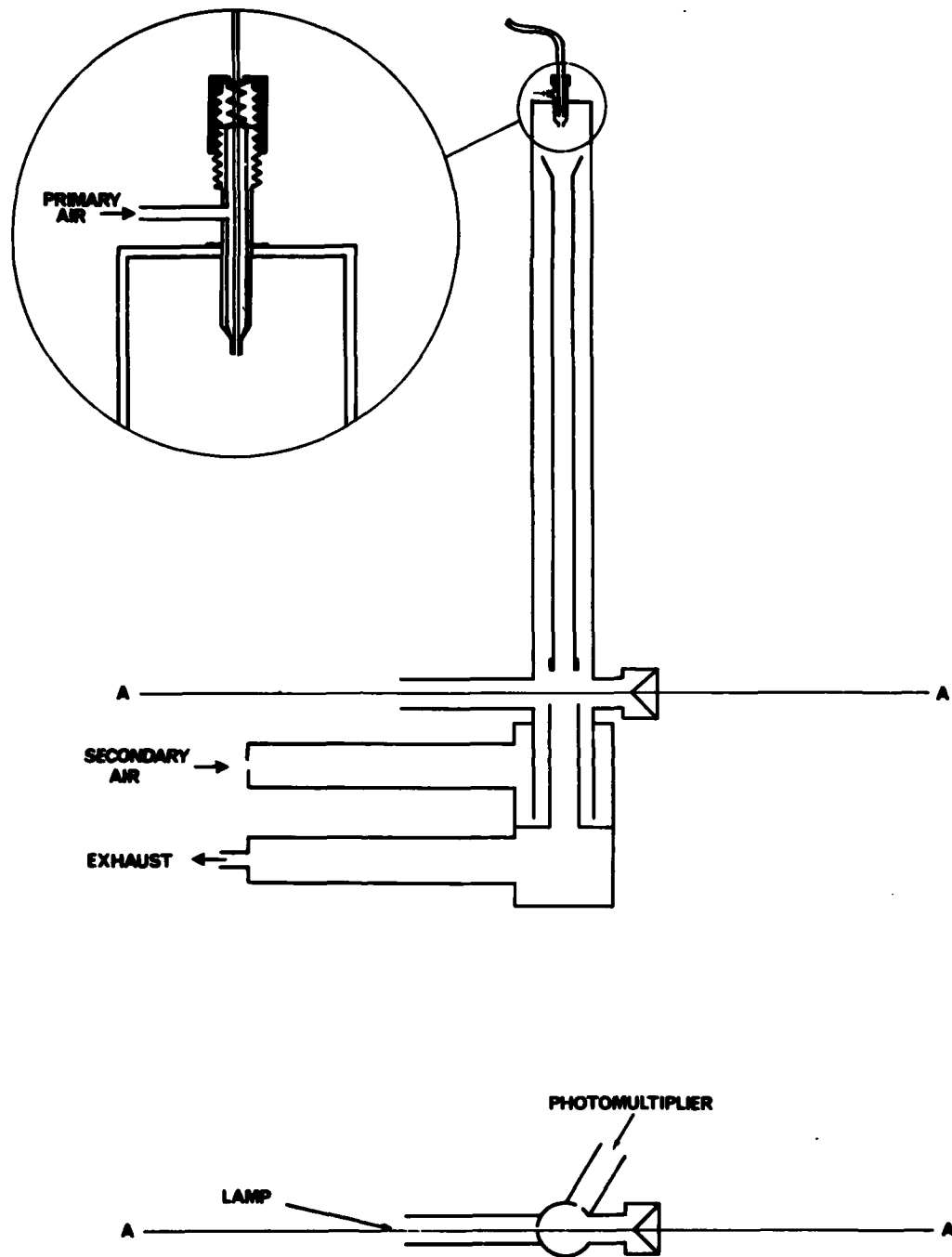

FIG. 3 - Schematic diagram - Clanor E.A. detector.

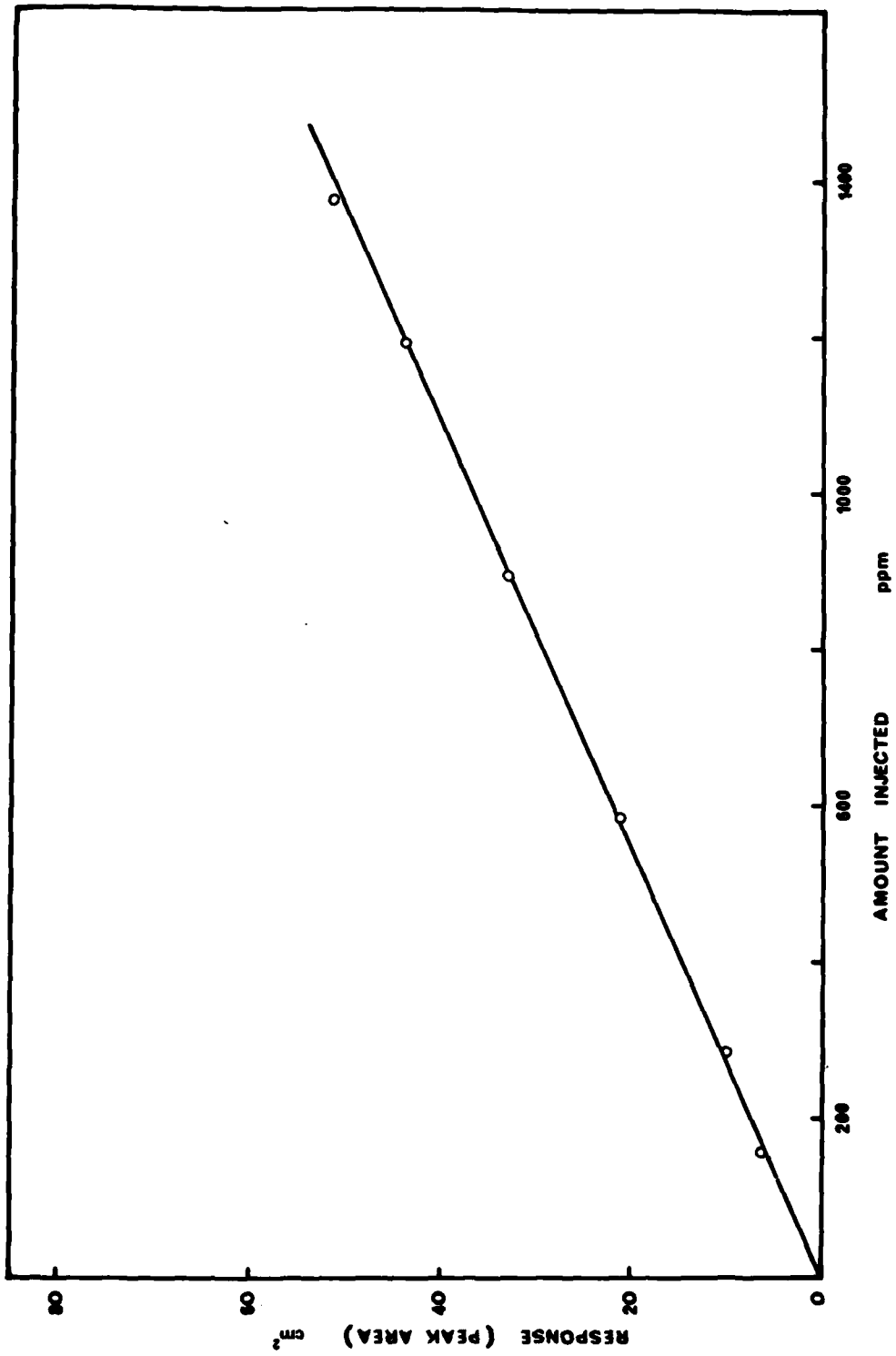

FIG. 4 - Dependence of R.I. detector response on solute concentration.

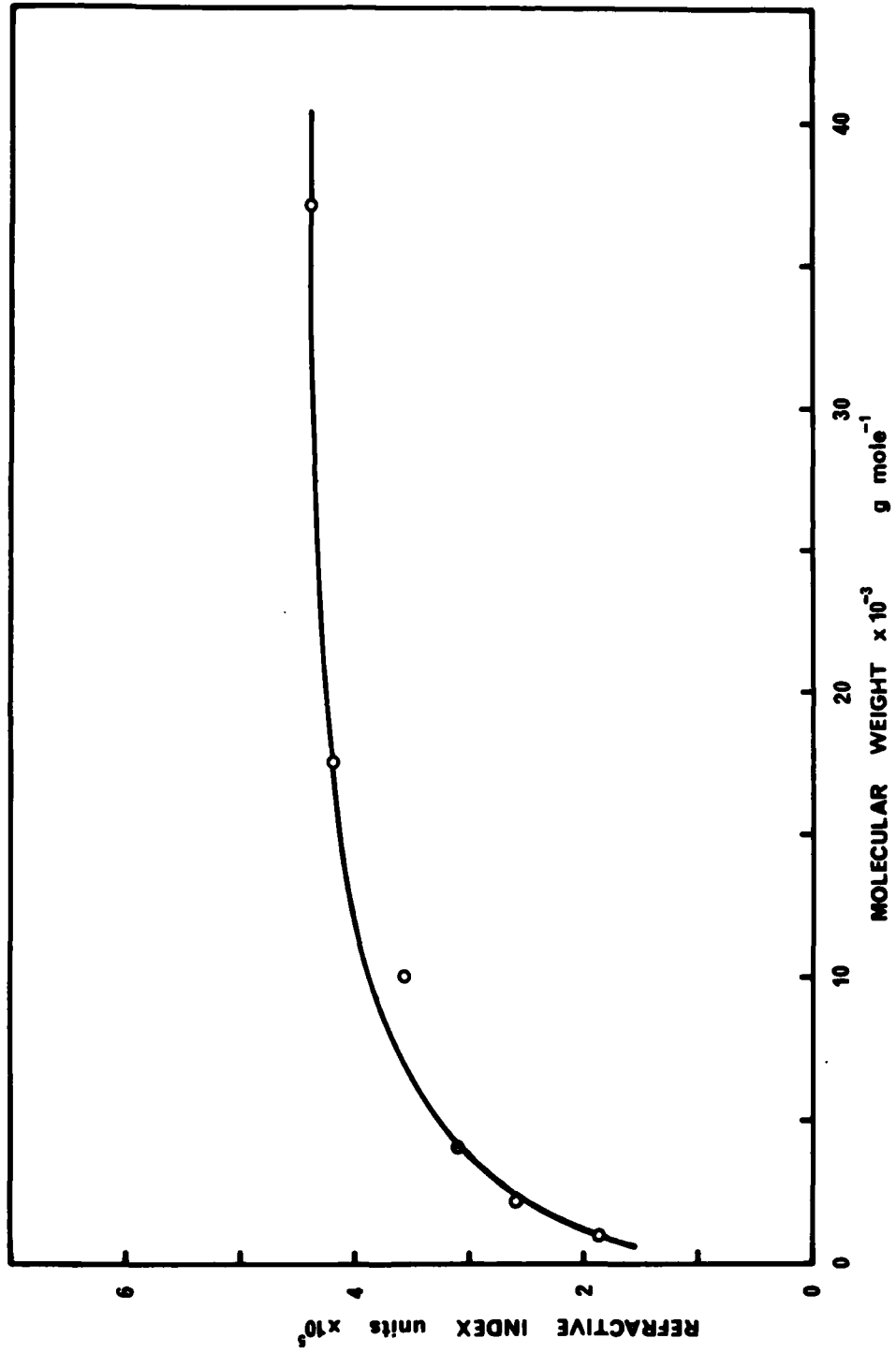

FIG. 5 - Dependence of R.I. detector response on solute molecular weight.

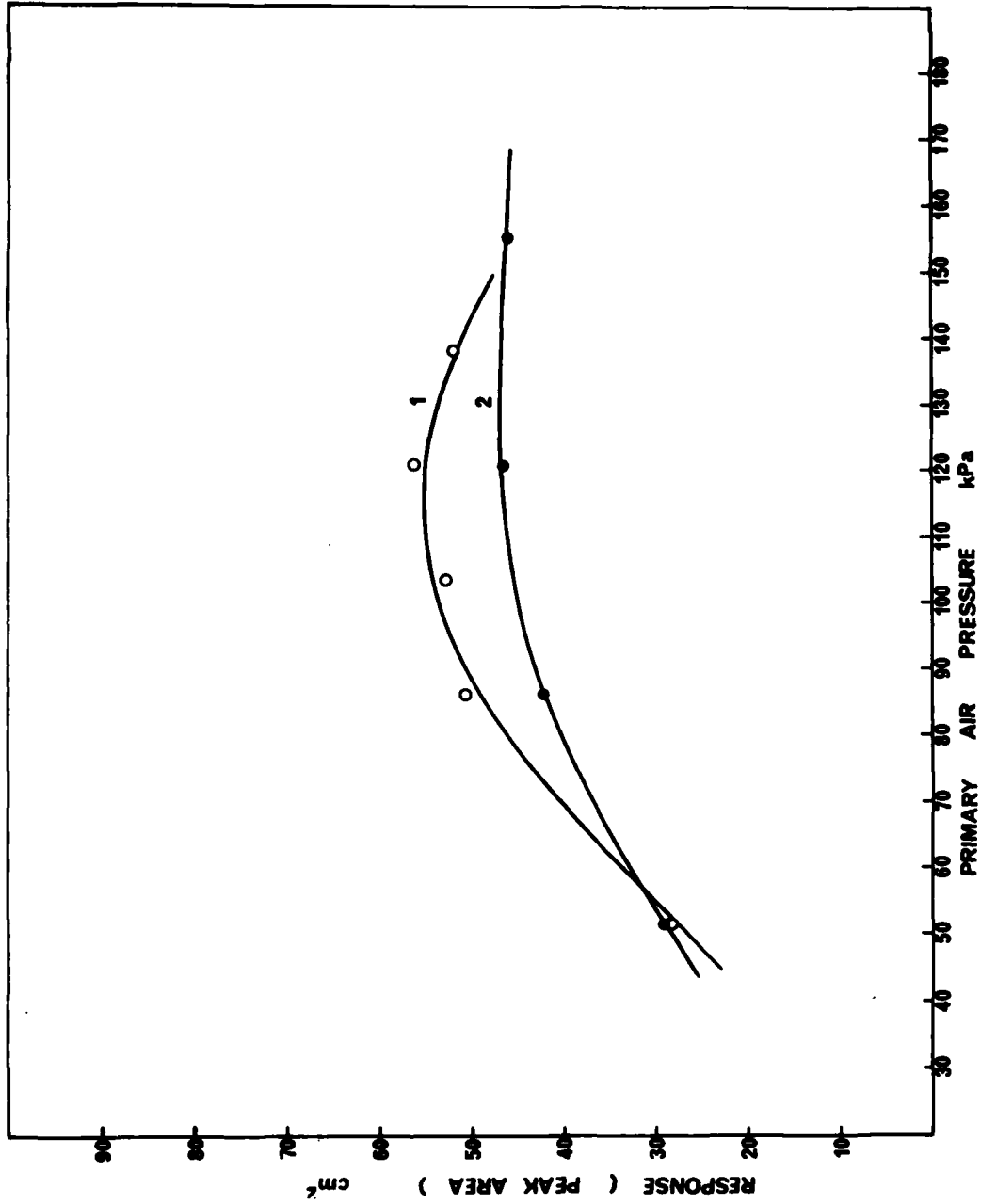

FIG. 6 - Dependence of E.A. detector response on primary air pressure.  
 Secondary air flow rate 14 l/h. 1. Initial results;  
 2. Repeated 3 months later.

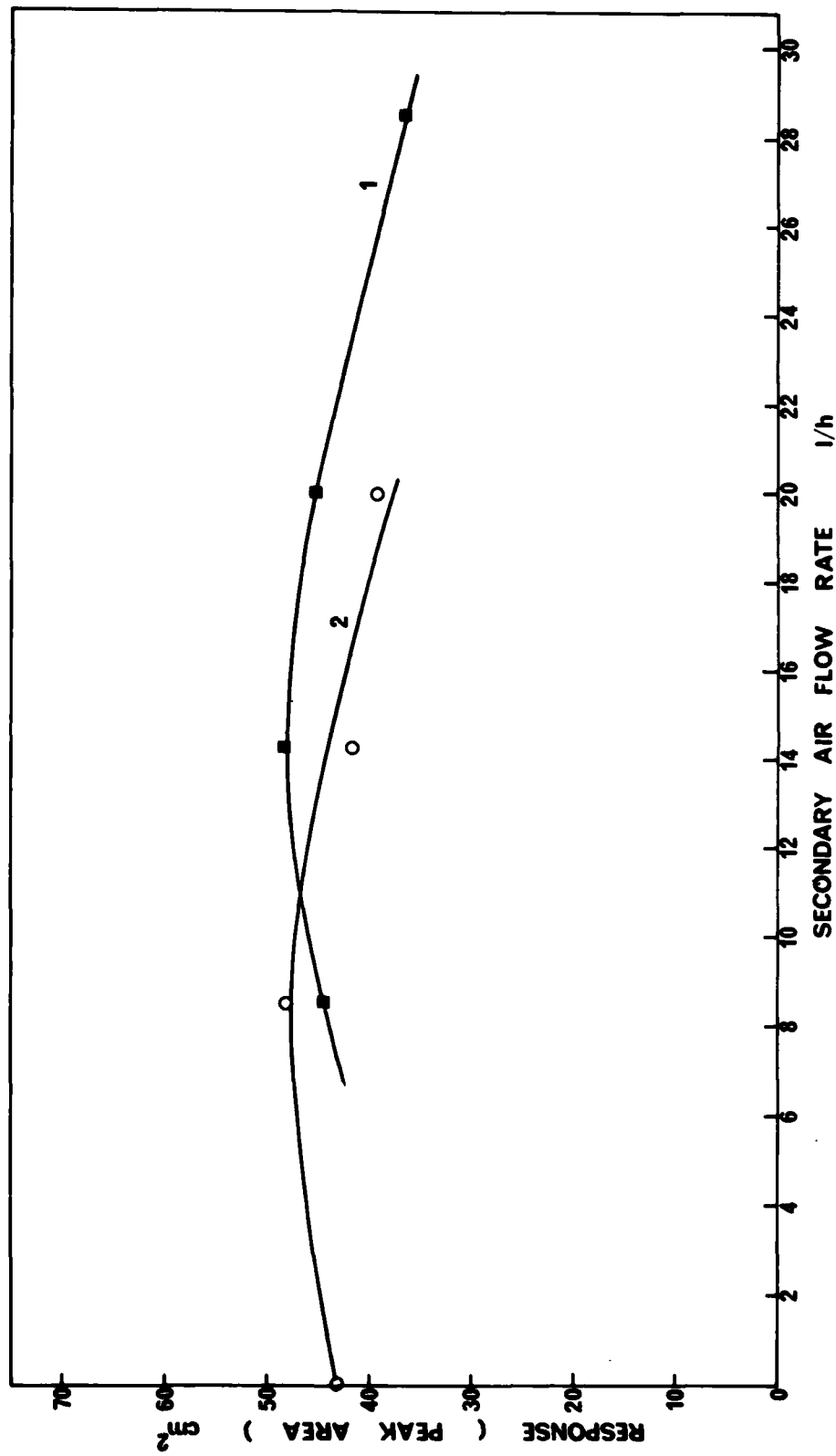

FIG. 7 - Dependence of E.A. detector performance on secondary air flow rate. Primary air pressure 125 kPa. 1. Initial results; 2. Repeated 3 months later.

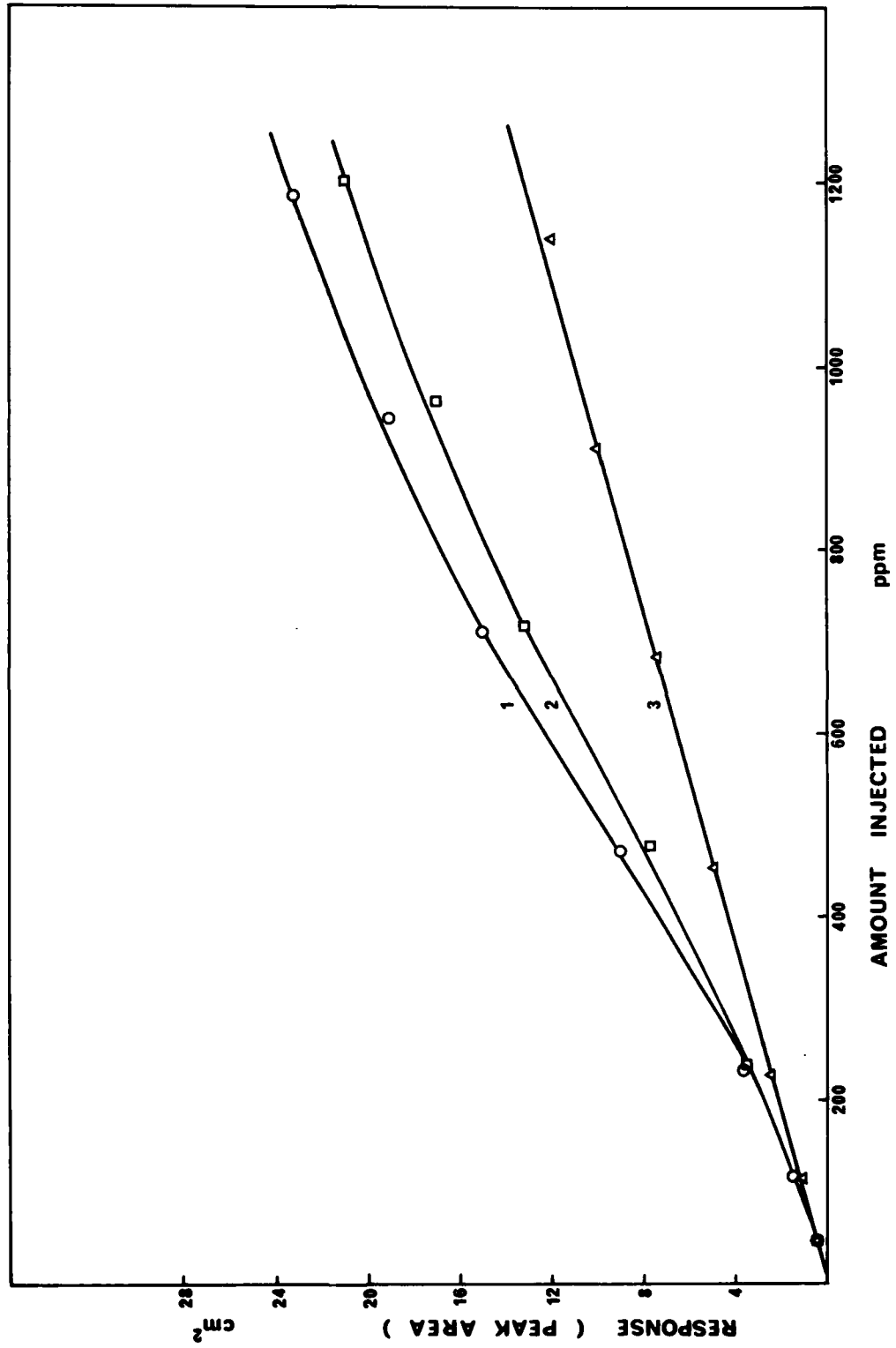

FIG. 8 - Dependence of E.A. detector performance on primary air pressure: the effect of sensitivity (490V). 1. 165 kPa; 2. 125 kPa; 3. 85 kPa.

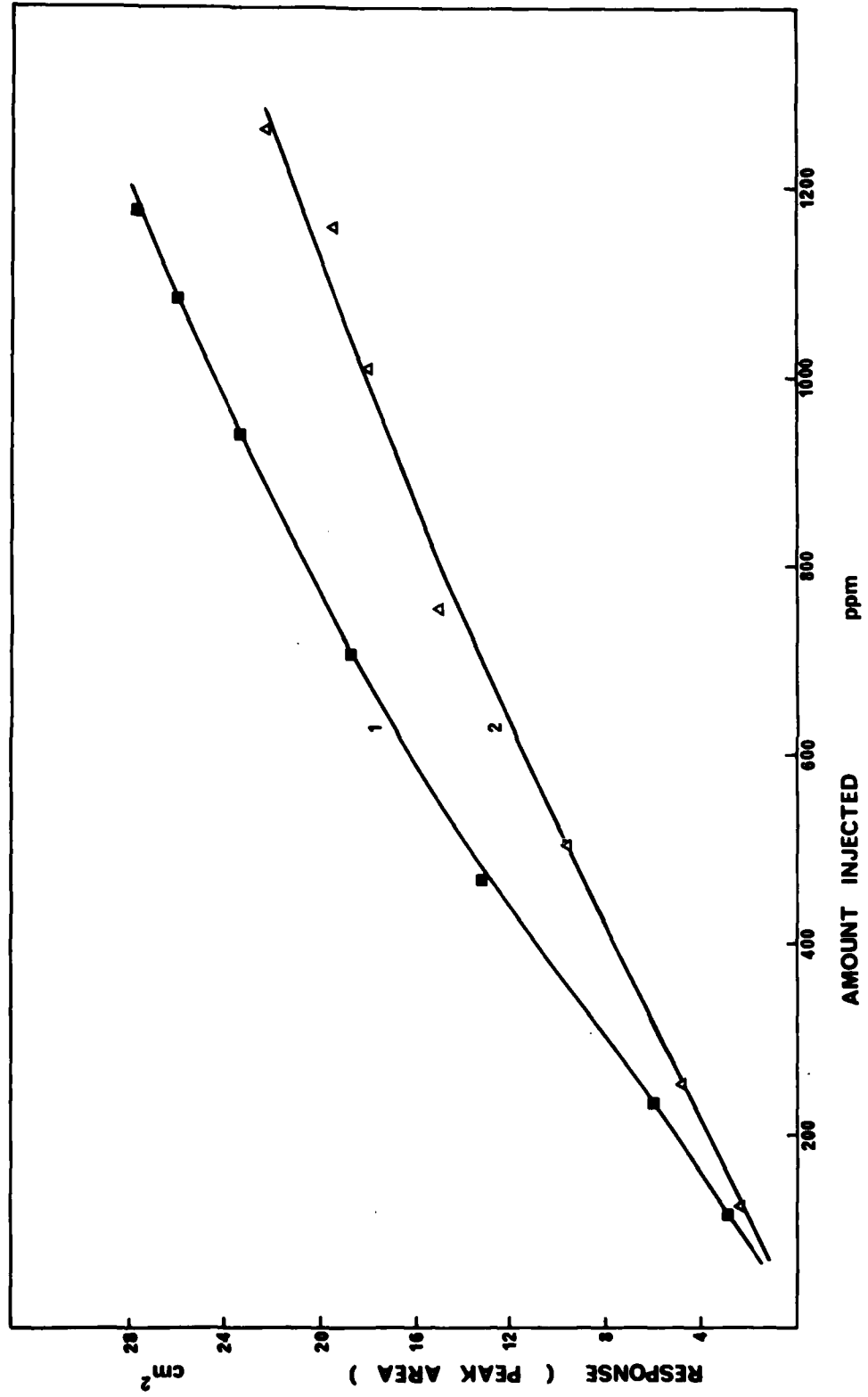

FIG. 9 - Dependence of E.A. detector performance on primary air pressure: the effect of sensitivity (530V). 1. 85 kPa; 2. 62 kPa.

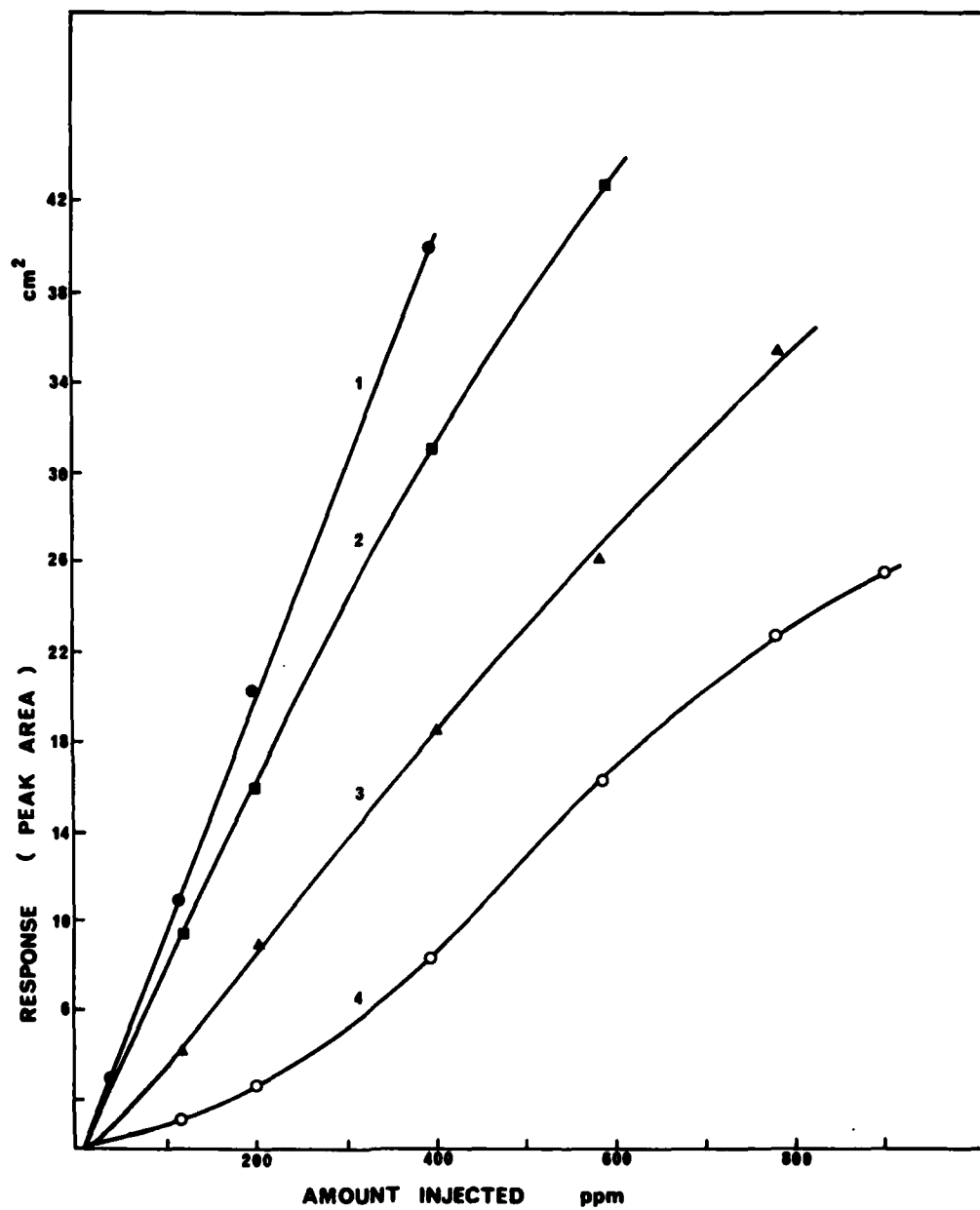

FIG. 10 - The effect of lamp voltage on E.A. detector performance.  
 1. 7.5V; 2. 7.0V; 3. 6.5V; 4. 6.0V.

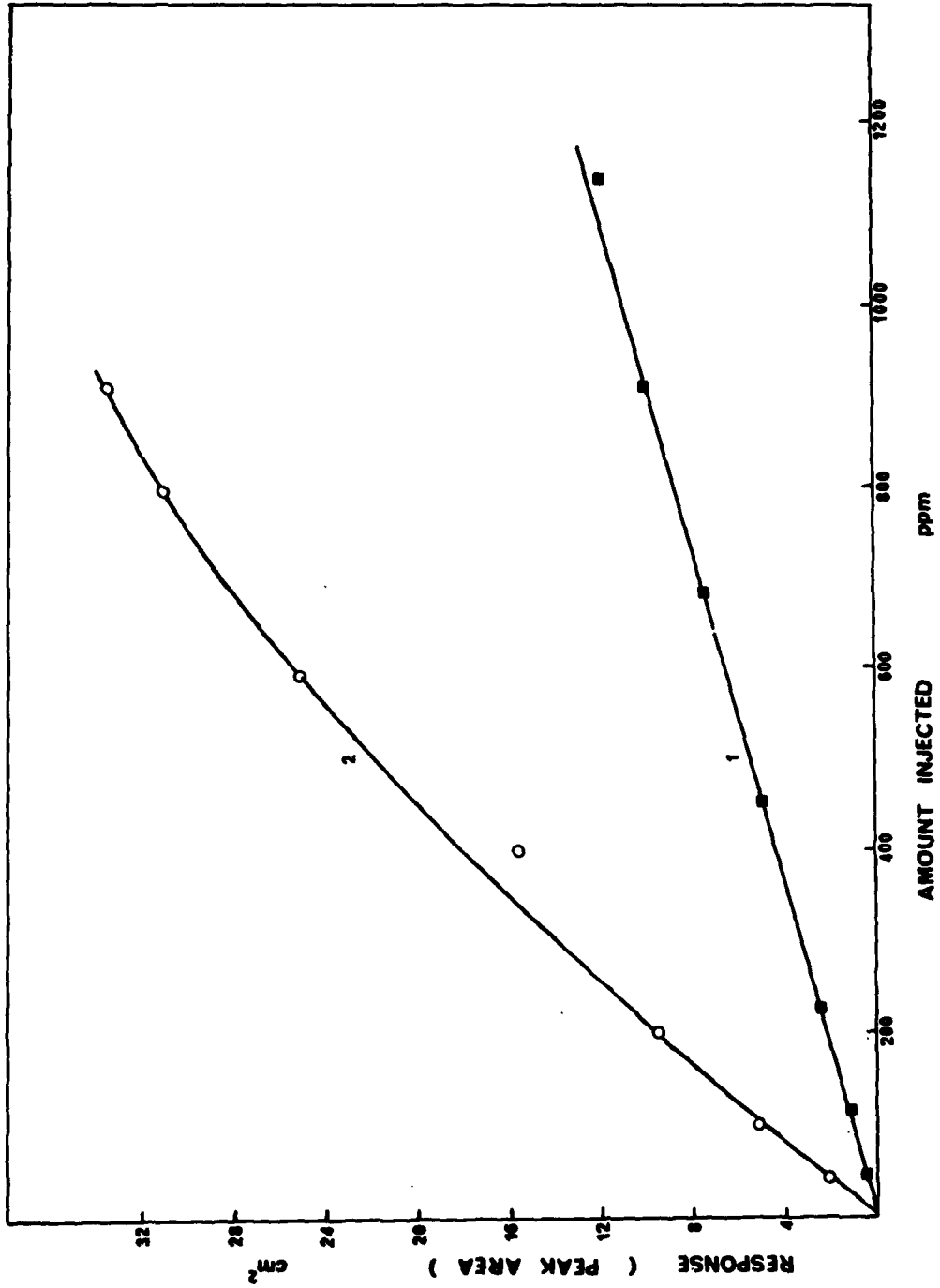

FIG. 11 - The effect of lamp age on E.A. detector performance.  
 1. Old Lamp; 2. New Lamp.

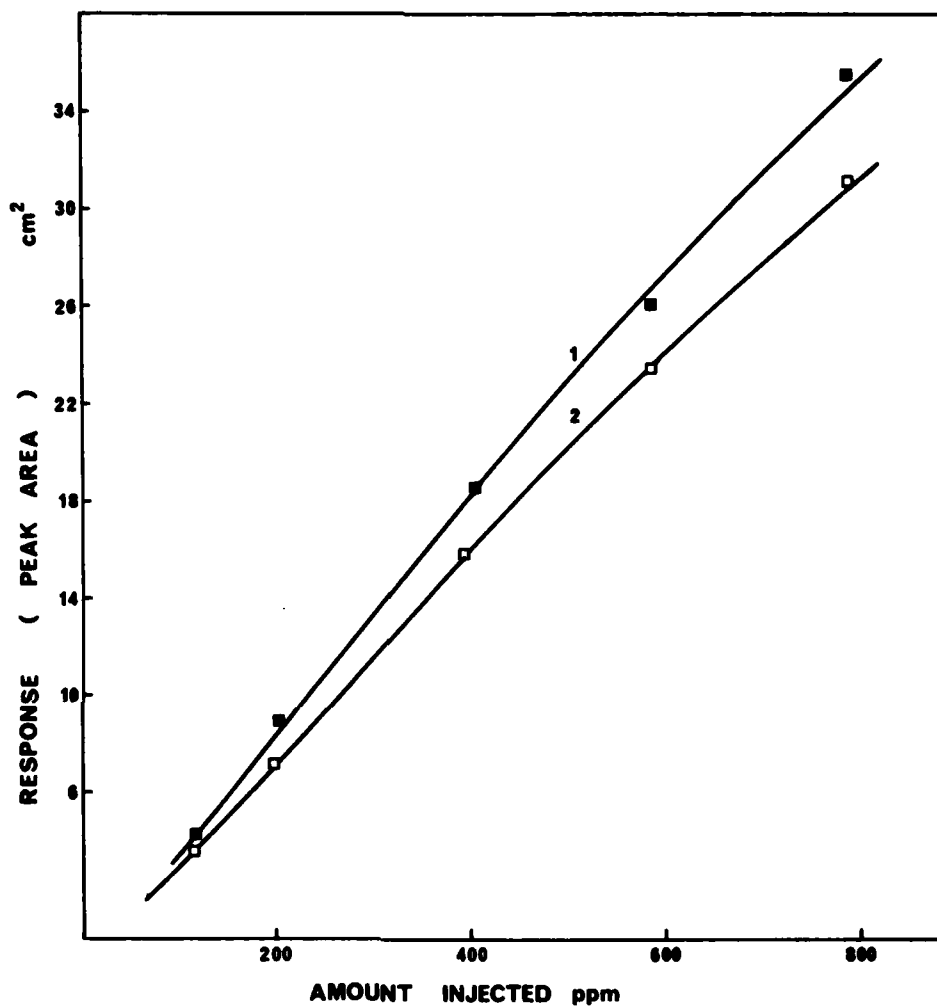

FIG. 12 - The effect of the exhaust system on E.A. detector performance.  
1. Exhaust system connected; 2. Exhaust system disconnected.

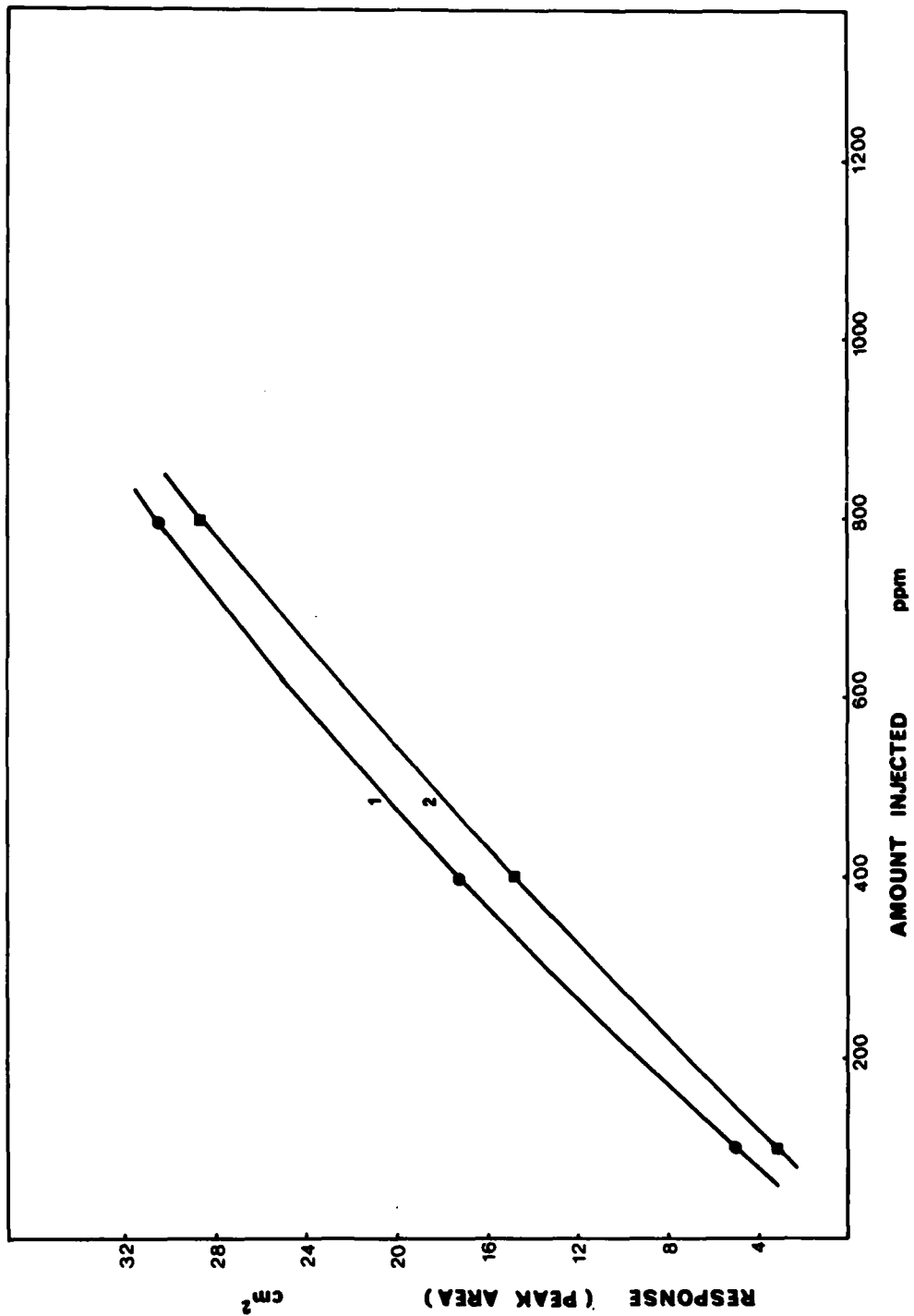

FIG. 13 - The effect of polymer type on E.A. detector performance.  
1. PS; 2. PMMA.

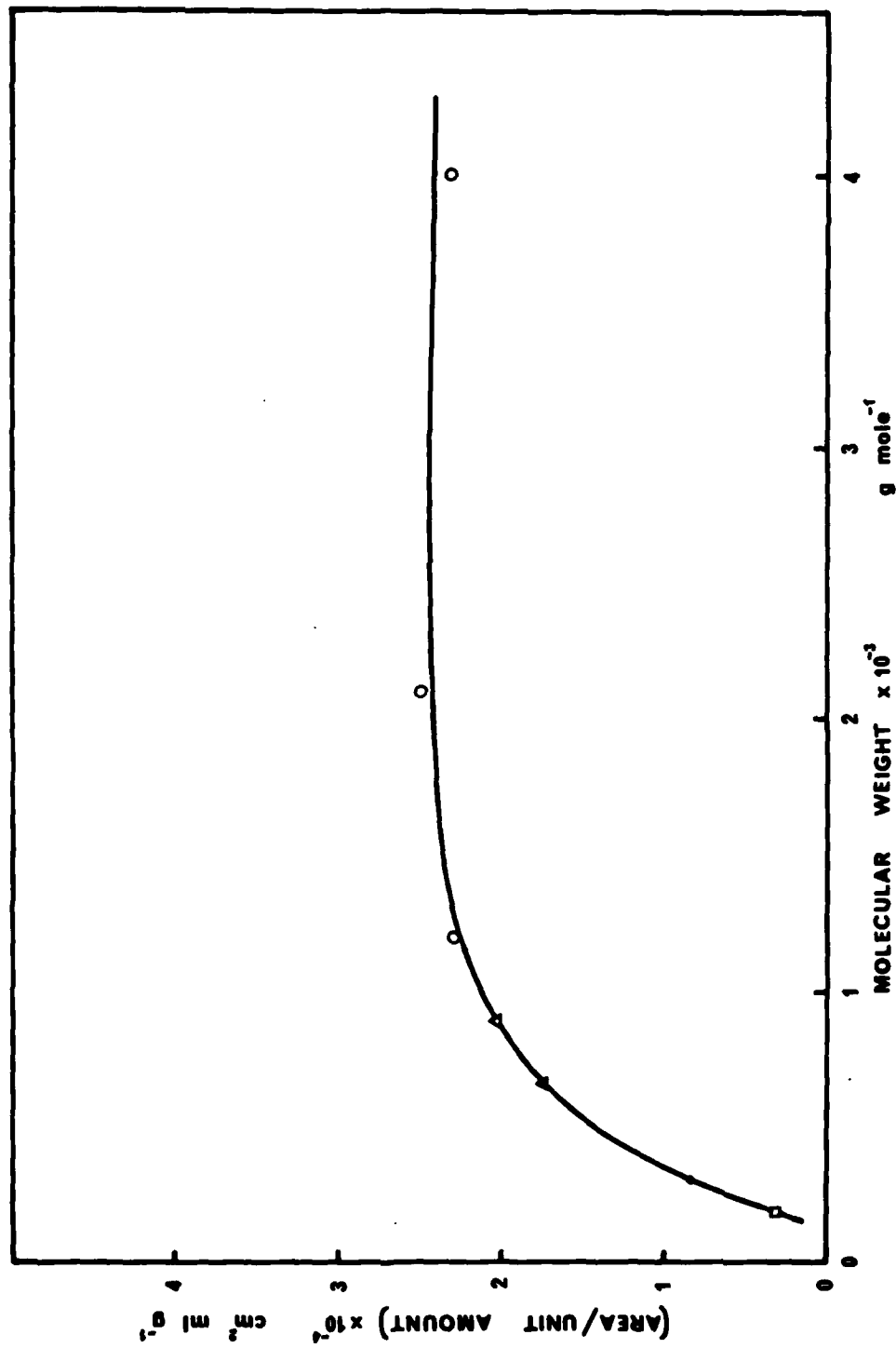

FIG. 14 - The dependence of E.A. detector performance on solute molecular weight.

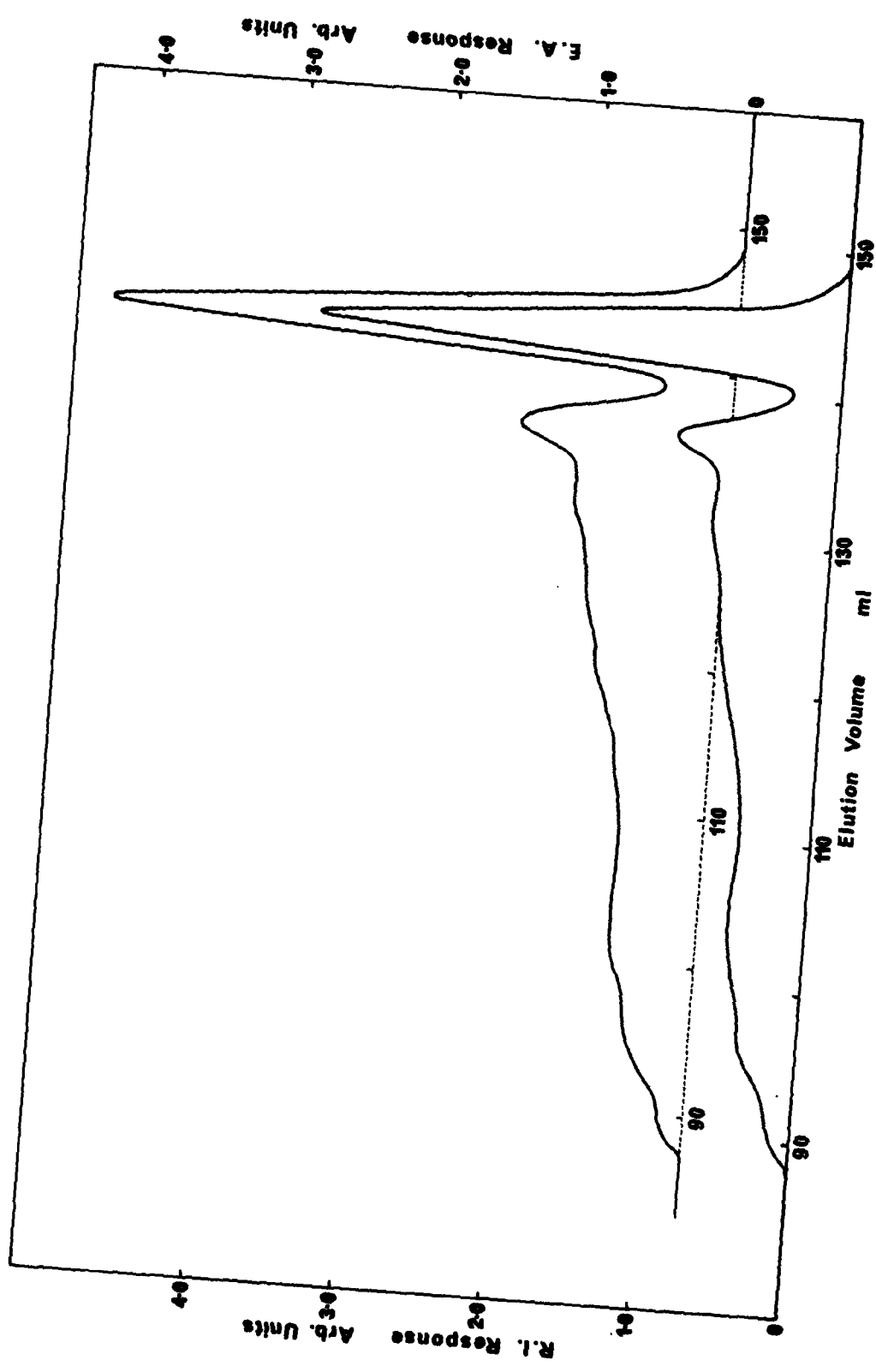

FIG. 15 - Chromatograms of the chloroform soluble part of an uncured aircraft adhesive.

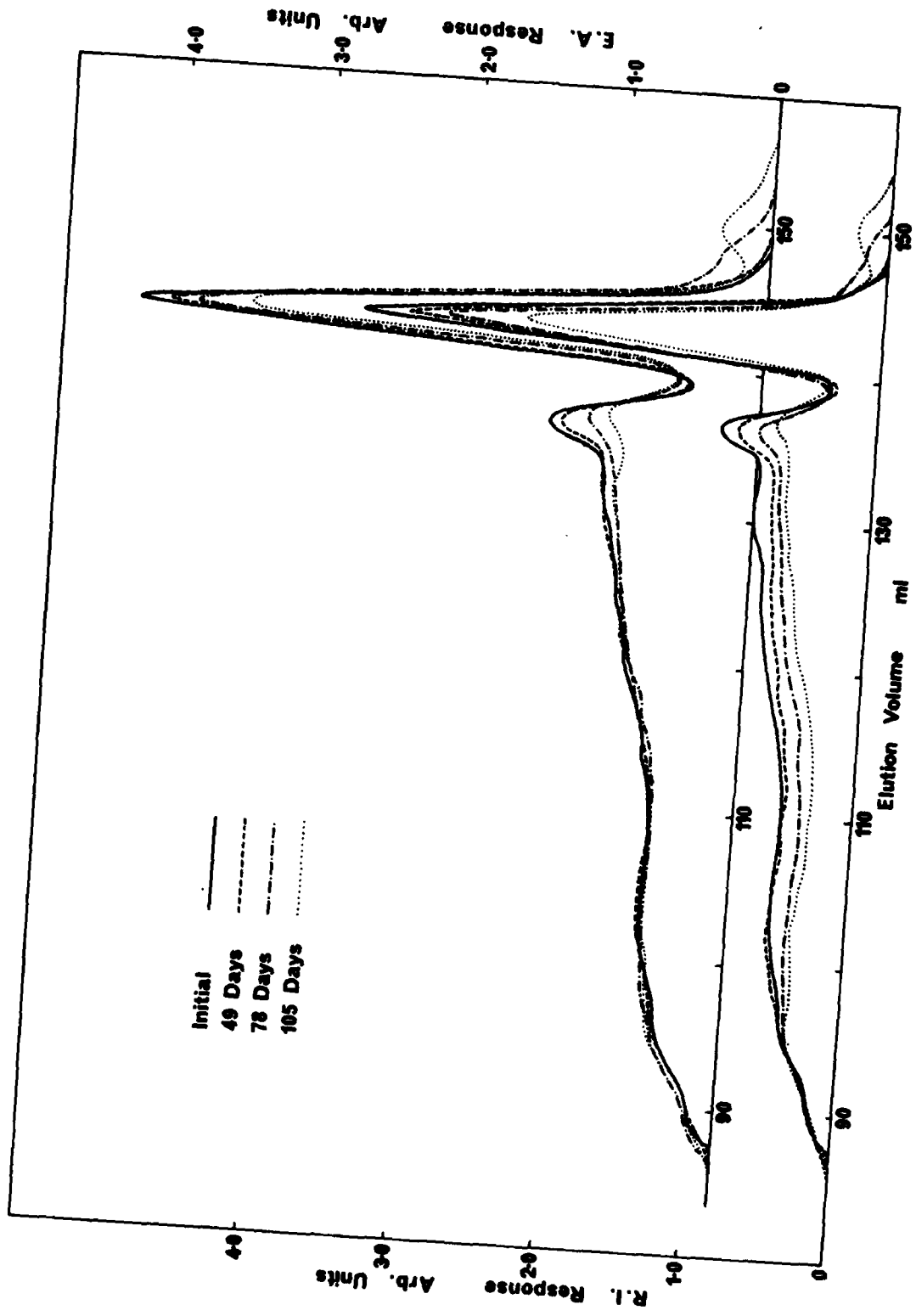

FIG. 16 - Room temperature ageing of an uncured aircraft adhesive.

(MRL-R-725)

DISTRIBUTION LIST

MATERIALS RESEARCH LABORATORIES

Chief Superintendent  
Superintendent, Organic Chemistry Division  
Dr. D.M. Pinkerton  
Dr. C.E.M. Morris  
Mr. I. Grabovac  
Library  
Librarian, N.S.W. Branch (Through Officer-in-Charge)  
Officer-in-Charge, Joint Tropical Trials & Research Establishment

DEPARTMENT OF DEFENCE

Chief Defence Scientist  
Deputy Chief Defence Scientist  
Controller, Projects and Analytical Studies  
Superintendent, Military Advisers Branch  
Head, Laboratory Programs Branch  
Army Scientific Adviser  
Air Force Scientific Adviser  
Naval Scientific Adviser  
Chief Superintendent, Aeronautical Research Laboratories  
Senior Librarian, Defence Research Centre  
Director, Defence Research Centre  
Librarian, R.A.N. Research Laboratory  
Officer-in-Charge, Document Exchange Centre (16 copies)  
Principal Librarian, Campbell Park Library ADSATIS Annex  
Central Office, Directorate of Quality Assurance - Air Force  
Director, Joint Intelligence Organisation  
Head, Engineering Development Establishment

DEPARTMENT OF PRODUCTIVITY

NASA Canberra Office  
Head, B.D.R.S.S. (Aust.)  
Controller, Munitions Supply Division  
Controller, Aircraft, Guided Weapons & Electronics Supply Division  
Manager, Government Aircraft Factory

OTHER FEDERAL AND STATE DEPARTMENTS AND INSTRUMENTALITIES

The Chief Librarian, Central Library, C.S.I.R.O.  
Australian Atomic Energy Commission Research Establishment  
Chief, Division of Applied Organic Chemistry, C.S.I.R.O.  
Chief, Division of Chemical Technology, C.S.I.R.O.

MISCELLANEOUS - AUSTRALIA

Dr. J. Shapiro, School of Chemistry, Macquarie University

(MRL-R-725)

DISTRIBUTION LIST

(Continued)

MISCELLANEOUS - OVERSEAS

Defence Scientific & Technical Representative, Australian High  
Commission, London  
Assistant Director/Armour and Materials, Military Vehicles and  
Engineering Establishment, England  
Reports Centre, Directorate of Materials Aviation, England  
Library - Exchange Desk, National Bureau of Standards, Washington  
U.S. Army Standardization Group, Office of the Scientific  
Standardization Representative, Canberra, A.C.T.  
Chief, Research and Development, Defence Scientific Information  
Service, Canada (2 copies)  
The Director, Defence Scientific Information & Documentation  
Centre, India  
Colonel B.C. Joshi, Military, Naval and Air Adviser, High Commission  
of India, Red Hill, A.C.T.  
Director, Defence Research Centre, Malaysia  
Exchange Section, British Library, England  
Periodicals Recording Section, Science Reference Library, British  
Library, England  
INSPEC: Acquisition Section, Institution of Electrical Engineers,  
England  
Overseas Reports Section, Defence Research Information Centre,  
England  
Engineering Societies Library, New York, U.S.A.  
Library, Chemical Abstracts Service, Columbus, Ohio, U.S.A.  
Director, Chemical Inspectorate, England  
Director, Propellants, Explosives & Rocket Motor Establishment,  
Essex, England  
Director, Royal Aircraft Establishment, England.